

# AirDuo SK

Installation  
Operation  
Commissioning  
Maintenance



# Contents

1. Introduction .....	3
2. Range.....	3
3. Operating Limits .....	3
4. Available assemblies.....	4
5. Unit identification.....	5
6. Technical characteristics: SK - CK .....	6
7. Technical characteristics: SK - CP .....	8
8. Safety advice.....	9
9. Transport and handling .....	9
Transport.....	9
Discharging of the unit .....	9
Centre of gravity coordinates .....	10
10. Location and assembling .....	13
Choice of location.....	13
Anchorage for silent-blocks.....	14
Minimum free space for commissioning and maintenance operations .....	16
Sound level .....	17
11. Checking before commissioning.....	18
Electrical connections .....	18
Condensate drain connection .....	23
Checks in the axial fans .....	24
Checks in the centrifugal fans .....	24
Checks in plug-fans (optional).....	25
Air ducts connections .....	25
Cooling connections.....	25
12. Safety elements .....	27
13. Optional.....	28
Mixing box (CK and CP).....	28
Supply plenum (CP).....	29
Electrical heaters (CK and CP) .....	30
Hot water coil (CK and CP).....	33
Stop-drop (CK).....	34
Filters (CK and CP).....	34
14. Commissioning.....	36
Checks prior to commissioning .....	36
Possible problems at commissioning .....	37
Operational checks .....	37
15. Maintenance.....	38
16. Control and analysis of breakdowns.....	41



# Split cooling units and heat pumps



Outdoor unit: SK



Indoor unit: CK



Indoor unit: CP



Cooling capacity: 20,6 to 134,8 kW

Heating capacity: 22,9 to 144,9 kW

## 1. INTRODUCTION

The **AirDuo** cooling units and heat pumps are units which feature a split-system construction with components optimised for the R-410A refrigerant. A vast number of options meet numerous operating demands.

The outdoor unit RSK/ISK allows the combination with two different indoor units: RCK/ICK (with horizontal construction) and RCP/ICP (with vertical construction).

### Outdoor unit: RSK/ISK

Unit equipped with an axial fan with free vertical supply, hermetic scroll-type compressor and electrical panel with electronic control.

Designed for installation outdoors.

- **RSK:** Outdoor unit **cooling-only** air-condensed.
- **ISK:** Outdoor air-air reversible **heat pump** unit.

### Indoor unit: RCK/ICK

Horizontal air-conditioning unit, equipped with centrifugal fan and expansion valve.

Designed for installation indoors, connected to a network of ducts.

- **RCK:** Indoor unit **cooling-only**
- **ICK:** Indoor reversible **heat pump**

### Indoor unit: RCP/ICP

Vertical air-conditioning unit, equipped with centrifugal fan and expansion valve

Designed for installation indoors, connected to a network of ducts.

- **RCP:** Indoor unit **cooling-only**
- **ICP:** Indoor reversible **heat pump**

The units comply with standards: EN 60-204 - EN 378-2, and directives: Machinery 2006/42/EC - EMC 2004/108/EC - LVD 2006/95/EC - PED 2014/68/EC (Category 2).

Those in charge of the installation, commissioning, operation and maintenance of the unit must know the instructions contained in this brochure and the specific technical characteristics of the installation place.

## 2. RANGE

	1 cooling circuit 1 compressor						2 cooling circuits 2 compressors							
	90	100	120	160	180	182	200	240	320	360	420	485	540	600
<b>RSK/ISK</b>	90	100	120	160	180	182	200	240	320	360	420	485	540	600
<b>RCK/ICK</b>	90	100	120	160	180	182	200	240	320	360	420	485	540	600
	--	--	--	--	--	--	2 x 100	2 x 120	2 x 160	2 x 180	--	--	--	--
<b>RCP/ICP</b>	90	100	120	160	--	182	200	240	320	360	--	--	--	--
	--	--	--	--	--	--	2 x 100	2 x 120	2 x 160	2 x 182	--	--	--	--

## 3. OPERATING LIMITS

Inlet air conditions		Cooling	Heating
Indoor coil	Minimum	14 °C WB	10 °C
	Maximum	22 °C WB	27 °C
Outdoor coil	Minimum	12 °C ①	-10 °C WB
	Maximum	48 °C	15 °C WB

① With control of operation condensation pressure activated up to -10°C.

### 4. AVAILABLE ASSEMBLIES

Both indoor units CK and CP can be coupled with mixing box which allow the management of free-cooling, air renewal and active recovery circuit. Available assemblies are:

#### CK - 90 to 360: assemblies with mixing box (plan view)

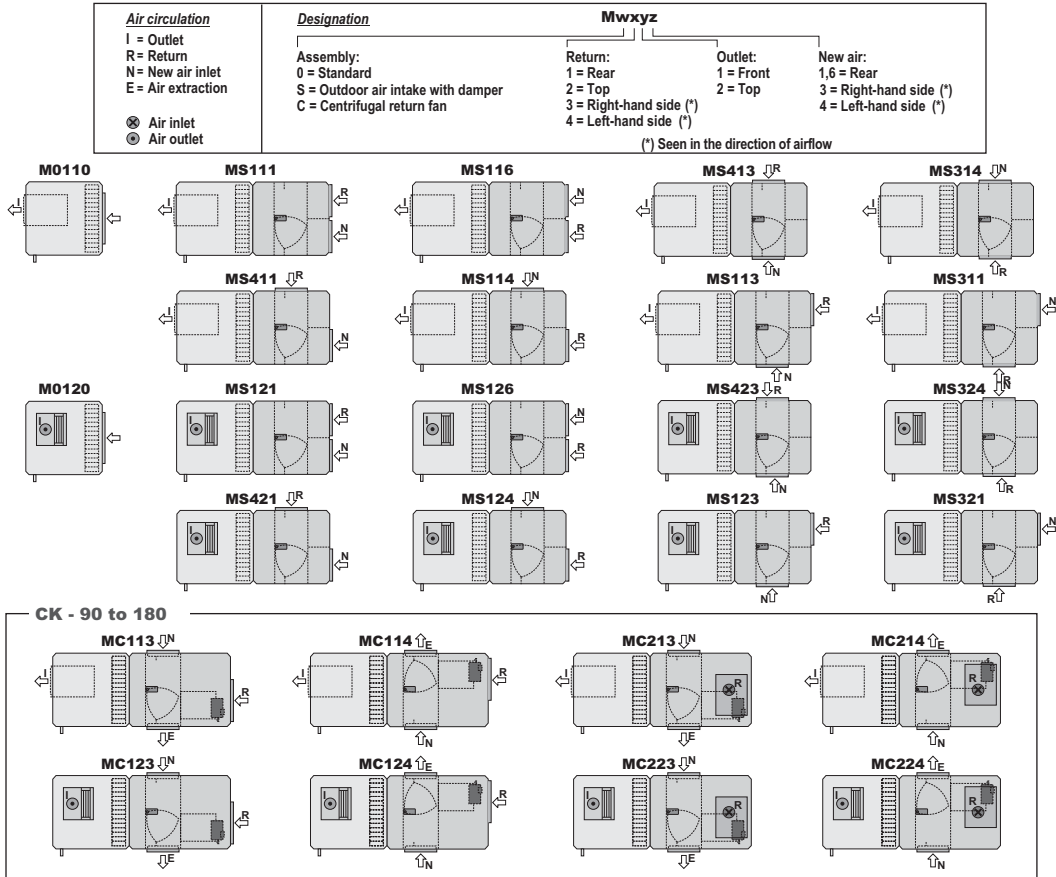

#### CK - 420 to 600: assemblies with mixing box (raised view)

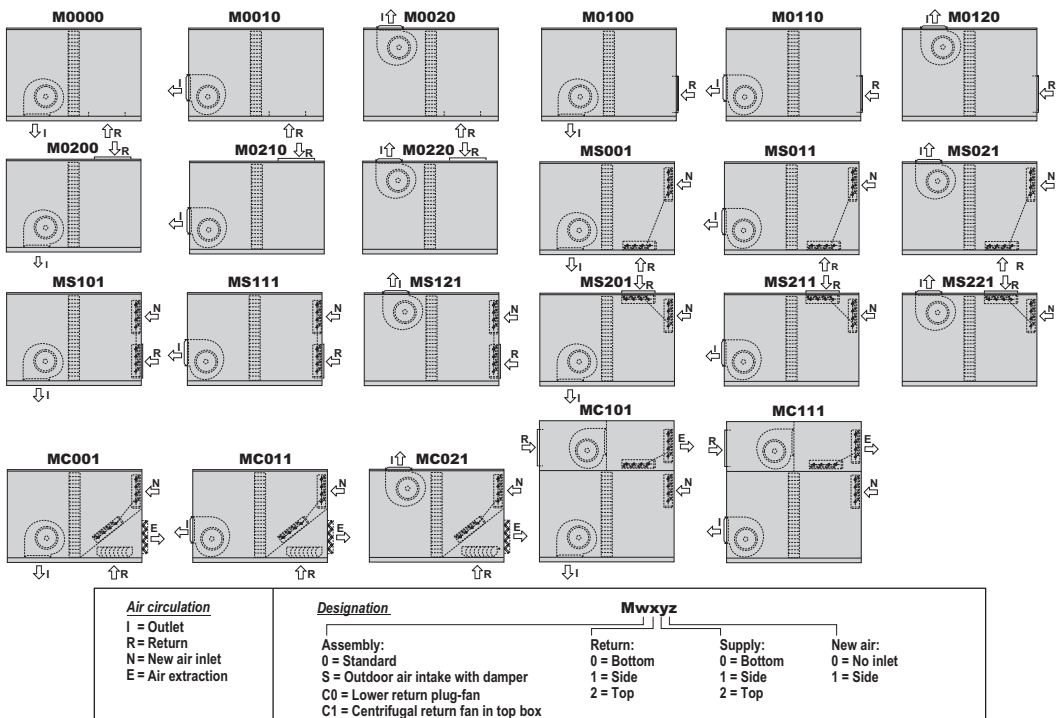

## CP - 90 to 360: assemblies with mixing box, MFHA horizontal module

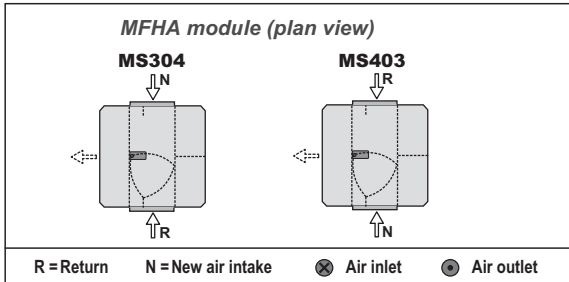

- 2 motorised dampers:
  - Outdoor air intake with damper, interlocked with return damper.

## CP - 182 to 360: assemblies with mixing box, MFVA vertical module

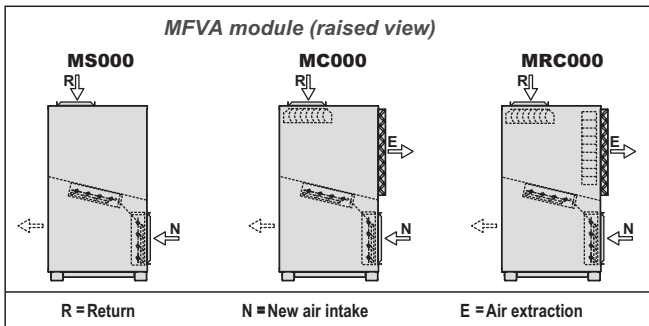

- 2 motorised dampers:
  - Outdoor air intake with damper, interlocked with return damper. Module: MS000
- 3 motorised dampers:
  - Return plug-fan. Module: MC000
  - Return plug-fan and recovery circuit. Module: MRC000

## 5. UNIT IDENTIFICATION

Check the condition of the equipment upon delivery.

Check that the details on the label, the packing and the data plate match the order.

If equipment has been damaged, or there is a shortfall in delivery, notify accordingly.

All units bear, legibly and indelibly, a data plate located in a prime space, as appears in the attached image: Check that this plate matches the correct model.



**Note:** The serial number must be used in all communications regarding the unit.

Ref. Product\Item Nbr		Designation\Description	
<input type="text" value="Order Nbr"/>		<input type="text" value="Model"/>	
An.Year	No Serie\Serial Nbr \ No Produit	Manufacturing Nbr	
<input type="text"/>	<input type="text"/>	<input type="text"/>	<input type="text"/>
Refrigerant	kW Absorbee\Input kW	Poids\Weight	
<input type="text" value="Refrigerant type"/>	<input type="text"/>	<input type="text" value="Weight in operation"/>	
Refrigerant kg	Tension\Voltage	Temperature Maxi C	
<input type="text"/>	<input type="text" value="Line voltage"/>	<input type="text"/>	
BP Mini PSM/MOP	Intensité\Current A	IP	
<input type="text" value="Low pressure"/>	<input type="text"/>	<input type="text"/>	
HP Maxi PSM/MOP	Int.. Kit Elect.	No CE	
<input type="text" value="High pressure"/>	<input type="text" value="Electrical kit current"/>	<input type="text"/>	
		30, av JeanFalconnier 01350 CULOZ Tel : 33(0)4 79 42 42 42	
		 Made in Spain	

### 6. TECHNICAL CHARACTERISTICS: SK - CK

SK		90	100	120	160	180	182	200
Cooling capacities	Cooling capacity ① (kW)	20,6	22,9	27,0	35,8	38,3	40,7	47,6
	Power input ③ (kW)	7,2	8,3	9,5	14,0	15,5	14,6	17,5
	EER performance	2,86	2,75	2,83	2,56	2,48	2,78	2,73
Heating capacities	Heating capacity ② (kW)	22,9	25,8	31,2	41,0	44,7	46,8	55,2
	Power input ③ (kW)	6,7	7,6	9,4	12,2	14,3	15,0	17,1
	COP performance	3,42	3,38	3,30	3,37	3,12	3,13	3,23
Outdoor circuit axial fan	Nominal air flow (m³/h)	10.000		14.200			20.000	
	Available static pressure (mm.w.c)	--						
	Number	1						
	Diameter (mm)	630			800			
	Output (kW)	0,7 / 0,4		0,8 / 0,5			2,0 / 1,3	
	Speed (r.p.m.)	875 / 650			680 / 540		895 / 705	
Compressor	Type	Scroll						
	No. compressors / No. circuits / No. stages	1 / 1 / 1						2 / 2 / 2
	Oil type	Copeland 3MAF 32 cST, Danfoss POE 160 SZ, ICI Emkarate RL32 CF, Mobil EAL Artic 22 CC						
	Volume of oil (l)	3,0	3,3	3,3	3,3	6,2	6,2	2 x 3,3
Cooling connections	Circuit 1: Liquid line	1/2"	1/2"	5/8"	5/8"	5/8"	5/8"	1/2"
	Circuit 1: Gas line	7/8"	1 1/8"	1 1/8"	1 1/8"	1 1/8"	1 1/8"	1 1/8"
	Circuit 2: Liquid line	--	--	--	--	--	--	1/2"
	Circuit 2: Gas line	--	--	--	--	--	--	1 1/8"
Refrigerant	Type	R-410A						
	Global warming potential (GWP) ④	2.088						
	Load up to 7,5 m (kg)	6,3	6,4	8,6	8,2	9,2	12,8	17,3
	Environment impact (tCO2 e)	13,2	13,4	18,0	17,1	19,2	26,7	36,1
Electrical features	Mains voltage	400 V / III ph / 50 Hz (±10%)						
	Power supply	3 Wires + Ground						
Maximum absorbed current	Compressor(s) (A)	15,3	18,5	20,1	25,1	29,1	29,1	37,0
	Fan (A)	1,3	1,3	2,2	2,2	2,2	4,3	4,3
	Control (A)	0,9	0,9	0,9	0,9	0,9	0,9	1,8
	Total (A)	17,5	20,7	23,2	28,2	32,2	34,3	43,1
Dimensions	Length (mm)	1.511			1.511			1.811
	Width (mm)	1.066			1.066			1.066
	Height (mm)	1.088			1.413			1.763
Weight	(kg)	275	281	317	326	368	388	490
CK		90	100	120	160	180	182	200
Indoor circuit centrifugal fan	Nominal air flow (m³/h)	4.000	4.600	5.200	7.000	7.000	8.000	9.200
	Available static pressure (mm.w.c)	15	15	15	15	15	15	20
	Number / turbines	1 / 1					2 / 2	
	Motor output (kW)	1,1	1,1	1,1	1,5	1,5	2 x 0,75	2 x 1,1
	Power input (kW)	0,61	0,83	0,88	1,08	1,08	2 x 0,59	2 x 0,91
	Speed (r.p.m.)	985	1049	916	761	761	963	1126
Max. absorbed current	Fan (A)	2,7	2,7	2,7	3,6	3,6	4,2	5,4
Dimensions	Length (mm)	1.190			1.520		2.144	
	Width (mm)	950			1.028		950	
	Height (mm)	731			731		731	
Weight	(kg)	147	147	190	199	199	262	262

① Cooling capacity calculated in accordance with the EN-14511-2013 standard given for indoor temperature conditions 27°C (19°C WB) and 35°C outdoor temperature.

② Heating capacity calculated in accordance with the EN-14511-2013 standard given for indoor temperature conditions 20°C and 6°C WB outdoor temperature.

③ Total power input by compressors and motorised fans under nominal conditions, calculated in accordance with the EN-14511-2013 standard.

④ Climatic warming potential of a kilogram of fluorinated greenhouse gas in relation to a kilogram of carbon dioxide over a period of 100 years.

## 6. TECHNICAL CHARACTERISTICS: SK - CK

SK		240	320	360	420	485	540	600	
Cooling capacities	Cooling capacity ① (kW)	52,8	71,2	82,5	100,9	108,7	122,9	134,8	
	Power input ③ (kW)	20,8	28,9	30,4	34,3	39,2	44,7	50,7	
	EER performance	2,55	2,46	2,72	2,94	2,77	2,75	2,66	
Heating capacities	Heating capacity ② (kW)	62,6	80,7	95,3	109,7	120,1	132,9	144,9	
	Power input ③ (kW)	20,4	25,7	32,2	34,5	39,8	42,9	47,3	
	COP performance	3,07	3,14	2,96	3,18	3,02	3,10	3,07	
Outdoor circuit axial fan	Nominal air flow (m³/h)	20.000		39.000		37.000			
	Available static pressure (mm.w.c)	--							
	Number	1		2					
	Diameter (mm)	800							
	Output (kW)	2,0 / 1,3							
	Speed (r.p.m.)	895 / 705							
Compressor	Type	Scroll							
	No. compressors / No. circuits / No. stages	2 / 2 / 2							
	Oil type	Copeland 3MAF 32 cST, Danfoss POE 160 SZ, ICI Emkarate RL32 CF, Mobil EAL Artic 22 CC							
	Volume of oil (l)	2 x 3,3	2 x 3,3	2 x 6,2	2 x 6,2	2 x 6,2	2 x 6,2	2 x 6,2	
Cooling connections	Circuit 1: Liquid line	5/8"	5/8"	5/8"	5/8"	5/8"	7/8"	7/8"	
	Circuit 1: Gas line	1 1/8"	1 1/8"	1 1/8"	1 1/8"	1 1/8"	1 1/8"	1 1/8"	
	Circuit 2: Liquid line	5/8"	5/8"	5/8"	5/8"	5/8"	5/8"	7/8"	
	Circuit 2: Gas line	1 1/8"	1 1/8"	1 1/8"	1 1/8"	1 1/8"	1 1/8"	1 1/8"	
Refrigerant	Type	R-410A							
	Global warming potential (GWP) ④	1.720							
	Load up to 7,5 m (kg)	17,4	22,2	22,7	31,4	31,4	33,4	33,6	
	Environment impact (tCO2 e)	36,3	46,4	47,4	65,6	65,6	69,7	70,2	
Electrical features	Mains voltage	400 V / III ph / 50 Hz (±10%)							
	Power supply	3 Wires + Ground							
Maximum absorbed current	Compressor(s) (A)	40,2	50,2	58,2	68,9	79,6	91,1	102,6	
	Fan (A)	4,3	4,3	8,6	8,6	8,6	8,6	8,6	
	Control (A)	1,8	1,8	1,8	1,8	1,8	1,8	1,8	
	Total (A)	46,3	56,3	68,6	79,3	90,0	101,5	113,0	
Dimensions	Length (mm)	1.811	1.811	2.201					
	Width (mm)	1.066	1.066	2.069					
	Height (mm)	1.763	2.063	1.966					
Weight (kg)	492	544	974	1.024	1.029	1.078	1.127		
CK		240	320	360	420	485	540	600	
Indoor circuit centrifugal fan	Nominal air flow (m³/h)	10.300	14.000	15.500	18.000	18.200	20.400	24.000	
	Available static pressure (mm.w.c)	20	20	20	20	20	20	20	
	Number / turbines	2 / 2			1 / 3				
	Motor output (kW)	2 x 1,5	2 x 1,5	2 x 2,2	4	4	4	5,5	
	Power input (kW)	2 x 0,94	2 x 1,15	2 x 1,39	2,52	2,82	2,96	3,40	
	Speed (r.p.m.)	974	789	816	677	677	643	681	
Max. absorbed current	Fan (A)	7,2	7,2	10,0	9,0	9,0	9,0	11,6	
Dimensions	Length (mm)	2.144	2.804		2.853				
	Width (mm)	950	1.028		2.160				
	Height (mm)	731	800		1.524				
Weight (kg)	262	365	365	920	920	963	964		

- ① Cooling capacity calculated in accordance with the EN-14511-2013 standard given for indoor temperature conditions 27°C (19°C WB) and 35°C outdoor temperature.  
 ② Heating capacity calculated in accordance with the EN-14511-2013 standard given for indoor temperature conditions 20°C and 6°C WB outdoor temperature.  
 ③ Total power input by compressors and motorised fans under nominal conditions, calculated in accordance with the EN-14511-2013 standard.  
 ④ Climatic warming potential of a kilogram of fluorinated greenhouse gas in relation to a kilogram of carbon dioxide over a period of 100 years.

### 7. TECHNICAL CHARACTERISTICS: SK - CP

SK		90	100	120	160	182	200	240	320	360	
Cooling capacities	Cooling capacity ① (kW)	20,6	22,8	26,7	35,3	40,6	47,6	52,3	70,0	81,3	
	Power input ③ (kW)	7,3	8,4	9,9	14,4	14,8	17,5	21,3	30,1	31,6	
	EER performance	2,83	2,71	2,70	2,45	2,75	2,72	2,45	2,33	2,57	
Heating capacities	Heating capacity ② (kW)	22,8	25,7	31,5	41,1	46,9	55,5	63,1	81,9	96,5	
	Power input ③ (kW)	6,8	7,7	9,8	12,6	15,1	17,4	21,0	26,9	33,4	
	COP performance	3,36	3,32	3,23	3,26	3,11	3,19	3,01	3,04	2,89	
Outdoor circuit axial fan	Nominal air flow (m³/h)	10.000		14.200		20.000				39.000	
	Available static pressure (mm.w.c)	--									
	Number x Diameter (mm)	1 x 630			1 x 800						2 x 800
	Output (kW)	0,7 / 0,4		0,8 / 0,5		2,0 / 1,3				2x(2,0/1,3)	
	Speed (r.p.m.)	875 / 650		680 / 540		895 / 705				895 / 705	
Compressor	Type	Scroll									
	No. compressors / circuits / stages	1 / 1 / 1				2 / 2 / 2					
	Oil type	Copeland 3MAF 32 cST, Danfoss POE 160 SZ, ICI Emkarate RL32 CF, Mobil EAL Artic 22 CC									
	Volume of oil (l)	3,0	3,3	3,3	3,3	6,2	2 x 3,3	2 x 3,3	2 x 3,3	2 x 6,2	
Cooling connections	Circuit 1: Liquid line	1/2"	1/2"	5/8"	5/8"	5/8"	1/2"	5/8"	5/8"	5/8"	
	Circuit 1: Gas line	7/8"	1 1/8"	1 1/8"	1 1/8"	1 1/8"	1 1/8"	1 1/8"	1 1/8"	1 1/8"	
	Circuit 2: Liquid line	--	--	--	--	--	1/2"	5/8"	5/8"	5/8"	
	Circuit 2: Gas line	--	--	--	--	--	1 1/8"	1 1/8"	1 1/8"	1 1/8"	
Refrigerant	Type	R-410A									
	Global warming potential (GWP) ④	2.088									
	Load up to 7,5 m (kg)	6,3	6,4	8,6	8,2	12,8	17,3	17,4	22,2	22,7	
	Environment impact (tCO2 e)	13,2	13,4	18,0	17,1	26,7	36,1	36,3	46,4	47,4	
Electrical features	Mains voltage	400 V / III ph / 50 Hz (±10%)									
	Power supply	3 Wires + GND									
Maximum absorbed current	Compressor(s) (A)	15,3	18,5	20,1	25,1	29,1	37,0	40,2	50,2	58,2	
	Fan(s) (A)	1,3	1,3	2,2	2,2	4,3	4,3	4,3	4,3	8,6	
	Control (A)	0,9	0,9	0,9	0,9	0,9	1,8	1,8	1,8	1,8	
	Total (A)	17,5	20,7	23,2	28,2	34,3	43,1	46,3	56,3	68,6	
Dimensions	Length (mm)	1.511		1.511		1.811		1.811		2.201	
	Width (mm)	1.066		1.066		1.066		1.066		2.069	
	Height (mm)	1.088		1.413		1.763		2.063		1.966	
Weight (kg)	275	281	317	326	388	490	492	544	974		

CP		90	100	120	160	182	200	240	320	360
Indoor circuit centrifugal fan	Nominal air flow (m³/h)	4.000	4.600	5.200	7.000	8.000	9.200	10.300	14.000	15.500
	Available static pressure (mm.w.c)	15	15	15	15	15	15	20	20	20
	Number / turbines	1 / 1				2 / 2				
	Motor output (kW)	1,1	1,5	2,2	2,2	2 x 1,1	2 x 1,5	2 x 2,2	2 x 2,2	2 x 3
	Power input (kW)	0,58	0,92	1,21	1,54	2 x 0,66	2 x 0,99	2 x 1,25	2 x 1,59	2 x 1,99
	Speed (r.p.m.)	1.076	1.132	1.199	997	1.040	1.120	1.241	1.020	1.064
Max. abs. current	Fan(s) (A)	2,7	3,6	5,0	5,0	5,4	7,2	10,0	10,0	13,8
Dimensions	Length (mm)	1.141		1.471		2.091		2.731		
	Width (mm) ⑤	859		859		859		859		
	Height (mm)	1.284		1.422		1.284		1.422		
Weight (kg)	166		216		290	320	320	410		

- ① Cooling capacity calculated in accordance with the EN-14511-2013 standard given for indoor temperature conditions 27°C (19°C WB) and 35°C outdoor temperature.
- ② Heating capacity calculated in accordance with the EN-14511-2013 standard given for indoor temperature conditions 20°C and 6°C WB outdoor temperature.
- ③ Total power input by compressors and motorised fans under nominal conditions, calculated in accordance with the EN-14511-2013 standard.
- ④ Climatic warming potential of a kilogram of fluorinated greenhouse gas in relation to a kilogram of carbon dioxide over a period of 100 years.
- ⑤ Upon request, it is possible to supply the frame of filters (146 mm) independently with the unit CP (713 mm), to be joined on site.



## 8. SAFETY ADVICE

To avoid any risk of accident during installation, commissioning or maintenance, it is obligatory to take into consideration the following specifications for the units: refrigerated circuits under pressure, refrigerant presence, electrical voltage presence and implantation place.

Because of all of this, only qualified and experienced personnel can perform maintenance tasks or unit repairs.



It is required to follow the recommendations and instructions in the maintenance brochures, the labels, and the specific instructions.

It is necessary to comply with the norms and regulations in effect. It is recommended to consult the competent authorities regarding the applicable regulations for users of units or components under pressure. The characteristics of these units or components are included on the plates of characteristics or in the regulatory documentation provided with the product.



The compressor and line surfaces can reach temperatures above 100°C causing burns to the body. In the same fashion, under certain conditions these surfaces can reach very cold temperatures that can cause freezing risks.



Use safety goggles and gloves on the job. Be careful with sharp parts or elements in the unit.



**Caution:** Before intervening in the unit, verify that the main power to the unit is cut off. An electric shock can cause personal damage.



**Note:** In order to recycle these units follow the stipulations of Directives 2002/96/EC and 2003/108/EC regarding electrical and electronic equipment and the management of the resulting waste.

### Refrigerant leaks:

A periodical check must be performed for refrigerant gas leaks as per Regulation (CE) N°517/2014 over **certain greenhouse effect fluoride gases**. Please, consult the frequency of checks in chapter of "Maintenance".

These units work with refrigerant gas **R-410A**. This fluid is used up to a maximum service pressure of 42 bar.

Components of the R-410A	R-32	R-125
Chemical formula	CH <sub>2</sub> F <sub>2</sub>	CHF <sub>2</sub> CF <sub>3</sub>
Weight ratio	50%	50%
Unitary global warming potential (GWP)	675	3.500
Global warming potential (GWP)	2.088	

In case of a leak:

- Toxicity: According to ASHRAE 34, R-410A belongs to the A1/A1 group, i.e. with high safety both in the mix and also in the case of a leak.
- Although it is not toxic, in case of a leak to atmospheric pressure the liquid phase evaporates. The resulting vapours are heavier than air and can displace the technician local air. In case of an accidental discharge in a closed enclosure, fans must be used to eliminate said vapours.
- Although the R-410A is not flammable, when in contact with a flame or hot spot it can decompose in fluorhydric acid HF and fluophosgene COF<sub>2</sub> with air highly toxic and corrosive.
- To detect leaks, an electronic leak detector, an ultraviolet lamp or soapy water must be used. Flame detectors do not help.



**Important:** Immediately repair any refrigerant leak, using a recovery unit specific for R-410A that avoids a possible mixture of refrigerants and/or oils.

## 9. TRANSPORT AND HANDLING

### Transport

The unit must be handled with care to avoid transport damage. Thus we recommend:

- Do not dispose of the transport supports or the packaging materials until the unit is in its final location.
- For transport in a container, one must be selected that has an easy load and unload to the installation location.

### Discharging of the unit

The unit can be discharged using:

- Forklift truck.
- Crane with a rocker arm and cloth slings (except models 90 to 360 of CK units and MFHA module).

When using any of the two above methods, it is always mandatory to grasp the unit by the points intended for that purpose, as described in this chapter.

Any handling of the unit by other means or by gripping points different from those described here may be dangerous for both the unit and the personnel who are carrying out the discharging or transport work.



Always check the weight of the set and verify that the discharging method used is approved for handling that weight.

Note: please see the weight and the gravity centre coordinates of each model stated in the following section.

### - Discharge via forklift truck:

The unit is designed to be transported safely by using a forklift truck. The forks of the forklift truck must come in on the side of the unit, ensuring that the centre of gravity of the unit remains within the forks, because a misbalance in the transport may cause the unit to turn over and fall from the forklift truck.

The recommended length for the forks will be bigger than the unit width, so that the entire weight-bearing structure can be supported on the forklift truck. This also prevents the possible introduction of the truck's fork into functional parts of the unit that may cause damage to the unit.

The standards and recommendations of the forklift truck must also be respected with regards to the maximum load, inclination of the fork carriage, elevation of the load for transport, and, in particular, the maximum speed.

**- Discharge via crane:**

A rocker arm, as well as approved cloth slings, both suitable for the dimensions and weight of the unit, must be used in order to carry out the work safely and without causing damage to the units or to workers.

These slings will be hooked to the two mounting holes located on each crossbar (in models 90 to 360 of CK units, CP units and MFVA module) or to the two grips screwed on each crossbar (in SK units and models 420 to 600 of CK units).

Make sure that the unit is protected from contact with the hooks to prevent damage to the housing.



The unit must be lifted and fixed with care, with maximum inclination of 15°, since it could harm its operation. Do not raise by points outside of those specified here.

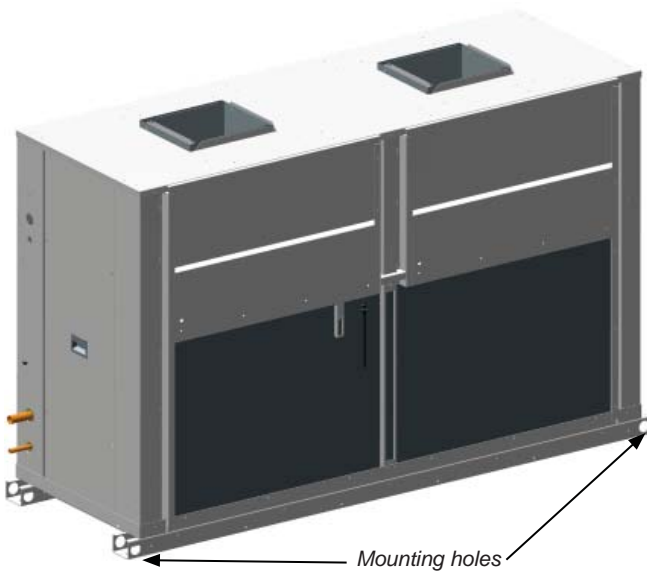

After the placing of the unit, it is recommended to remove the grips, as they can be a hindrance for maintenance. Put the grips back in case of unit transport. Each grip is fixed to the crossbar using two M10 screws.

**Centre of gravity coordinates**

Both the weight and the centre of gravity should be consulted before the transport and handling of the unit.

SK	Centre of gravity (mm)			Weight (kg)
	X	Y	Z	
90	945	602	440	275
100	945	602	440	281
120	908	595	589	317
160	913	595	593	326
180	909	584	512	368
182	909	584	512	388
200	1.029	610	658	490
240	1.030	609	657	492
320	1.019	605	777	544
360	1.280	1.110	795	974
420	1.254	1.111	807	1.024
485	1.256	1.108	805	1.029
540	1.278	1.129	780	1.078
600	1.297	1.104	757	1.127

**SK - 90 to 320**

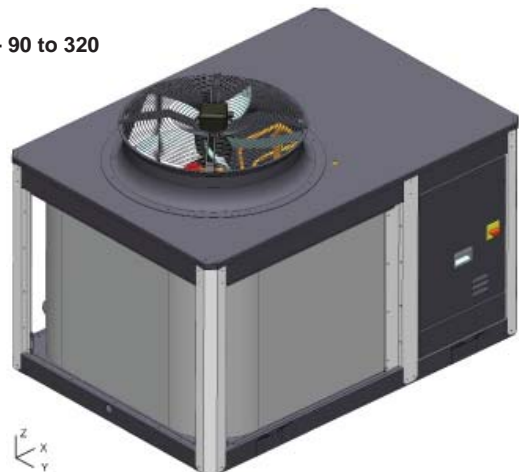

**SK - 360 to 600**

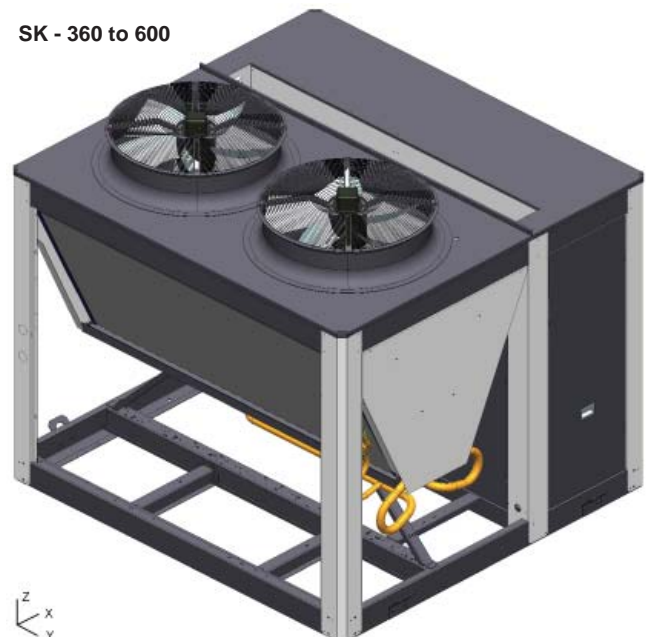

CK	Centre of gravity (mm)			Weight (kg)
	X	Y	Z	
90	539	327	391	147
100	539	327	391	147
120	539	327	391	190
160	757	346	387	199
180	757	346	387	199
182	1.048	333	390	262
200	1.048	333	390	262
240	1.048	333	390	262
320	1.384	330	416	365
360	1.384	330	416	365
420	924	1.346	676	920
485	924	1.346	676	920
540	931	1.348	682	963
600	931	1.350	682	964

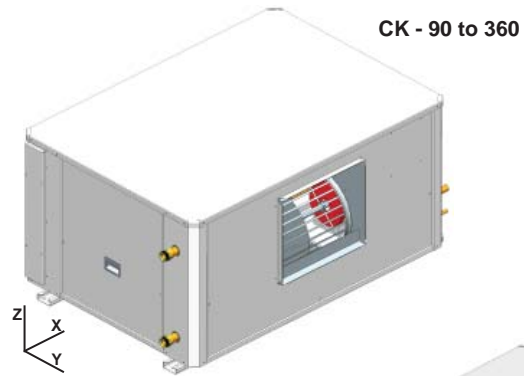

MS module for CK - 90 to 360

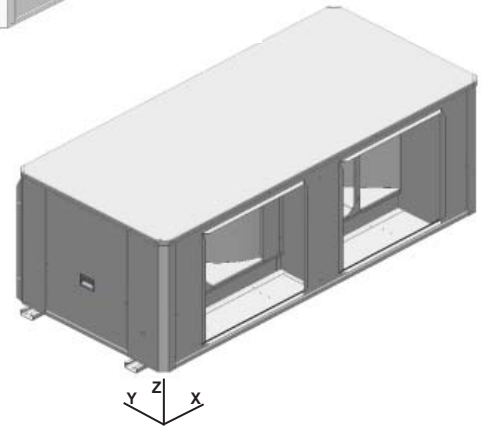

MC module for CK - 90 to 180

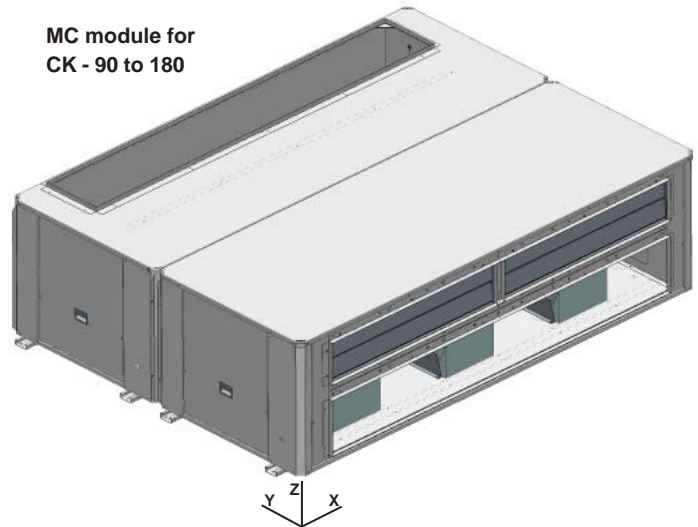

MS module	CK	Centre of gravity (mm)			Weight (kg)
		X	Y	Z	
Asemblies - 111, 116, 413, 314, 411, 114, 113, 311, 121, 126, 423, 324, 421, 124, 123, 321	90 / 100 / 120	558	459	330	98
	160 / 180	723	465	327	118
	182 / 200 / 240	1.030	436	327	152
	320 / 360	1.360	471	360	200

MC module	CK	Centre of gravity (mm)			Weight (kg)
		X	Y	Z	
Asemblies - 113, 114, 123, 124	90 / 100 / 120	455	513	418	223
	160 / 180	620	650	418	267
Asemblies - 213, 214, 223, 224	90 / 100 / 120	664	513	418	223
	160 / 180	879	650	418	267

CK	Assembly	Centre of gravity (mm)			Weight (kg)
		X	Y	Z	
420	MS	1.104	1.346	699	1.000
	MC0	1.081	1.346	654	1.180
	MC1	1.156	1.346	933	1.626
485	MS	1.106	1.346	699	1.000
	MC0	1.085	1.346	654	1.180
	MC1	1.158	1.346	937	1.626
540	MS	1.106	1.346	699	1.000
	MC0	1.088	1.348	660	1.223
	MC1	1.158	1.348	938	1.669
600	MS	1.107	1.350	705	1.044
	MC0	1.088	1.350	660	1.224
	MC1	1.148	1.350	930	1.697

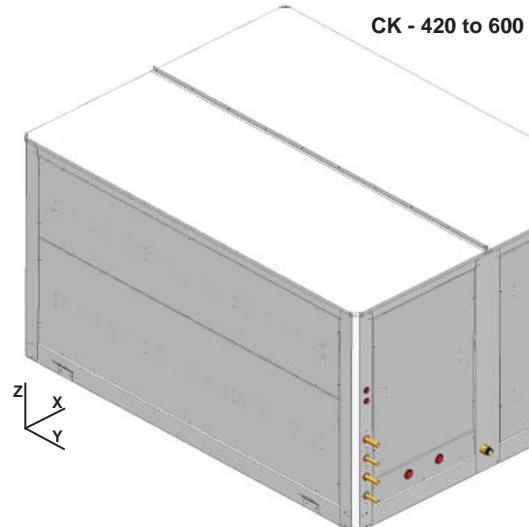

CP		Centre of gravity (mm)			Weight (kg)
		X	Y	Z	
90	Centrifugal fan	515	408	541	174
	Plug-fan	515	408	541	174
100	Centrifugal fan	515	408	541	174
	Plug-fan	515	408	541	174
120	Centrifugal fan	515	408	541	174
	Plug-fan	515	408	541	174
160	Centrifugal fan	650	241	588	227
	Plug-fan	650	241	588	215
182	Centrifugal fan	989	428	537	305
	Plug-fan	989	428	537	301
200	Centrifugal fan	985	442	520	305
	Plug-fan	985	442	520	301
240	Centrifugal fan	985	442	520	336
	Plug-fan	985	442	520	331
320	Centrifugal fan	1306	428	625	431
	Plug-fan	1306	428	625	413
360	Centrifugal fan	1306	428	625	431
	Plug-fan	1306	428	625	413

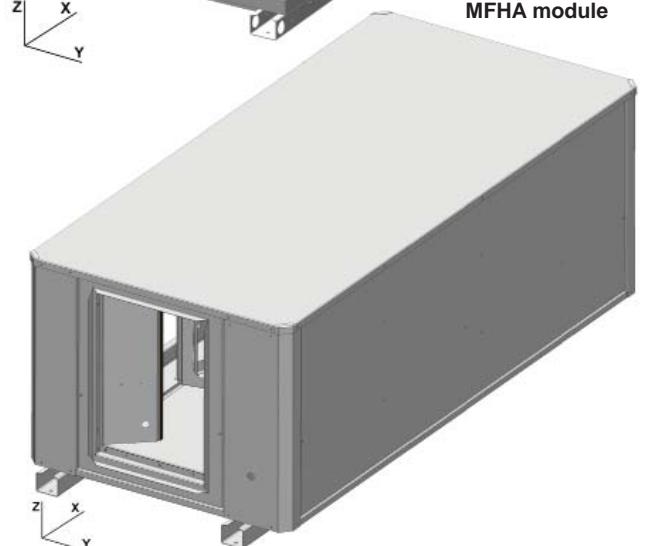
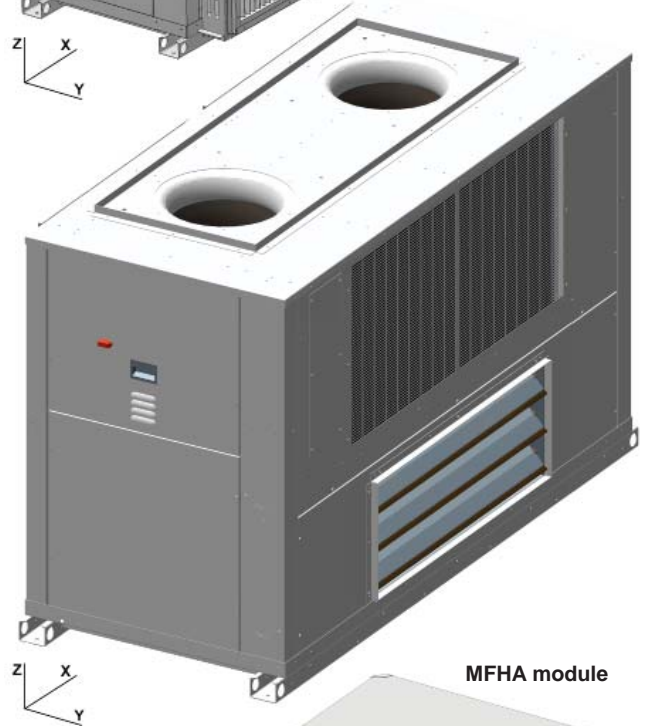
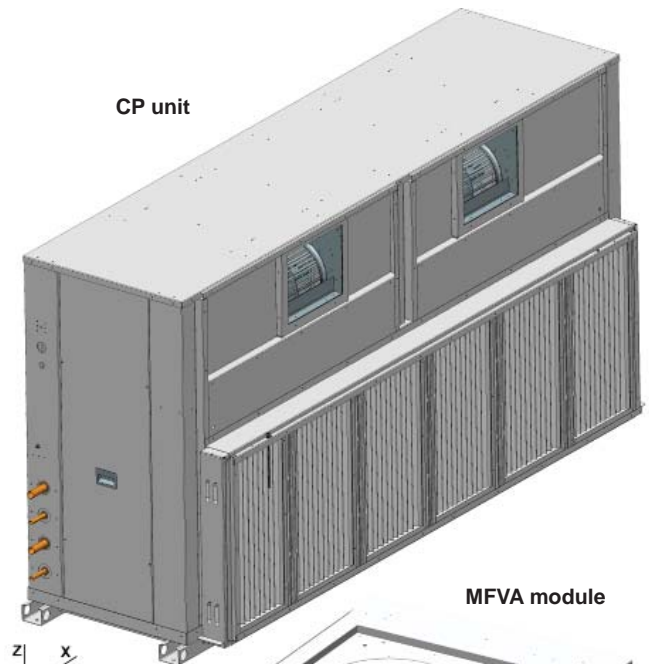

MFVA module		Centre of gravity (mm)			Weight (kg)
		X	Y	Z	
182 / 200 / 240	MS000	1025	428	555	221
	MC000	1034	425	663	292
	MRC000	1081	405	569	367
320 / 360	MS000	1327	437	607	297
	MC000	1343	447	729	397
	MRC000	1404	426	626	502

MFHA module		Centre of gravity (mm)			Weight (kg)
		X	Y	Z	
90 / 100 / 120	MS304 / MS403	558	459	330	98
160	MS304 / MS403	723	465	327	118
182 / 200 / 240	MS304 / MS403	1.030	514	327	152
320 / 360	MS304 / MS403	1.360	557	360	200

## 10. LOCATION AND ASSEMBLING

### Choice of location

When choosing the location, whatever may be the selected fashion, the following precautions have to be taken into consideration:

- It is mandatory to comply with norm EN 378-3 on Safety and Environmental Requirements. Part 3: "In situ" installation and protection to people.
- The area where the unit will be located must be perfectly accessible for cleaning and maintenance operations (check minimum free space for maintenance). Leave enough space for air circulation around the unit.
- It is necessary to check that the surface of the floor or the structure supports the weight of the unit (please, consult the weight of the unit in the section "Centre of gravity coordinates").
- It is necessary to ensure that the surface where the unit is going to be installed is completely flat. Any defect in the preparation of the unit support surface translates into stresses on the structure, which may result in its deformation.
- These units can be installed on the floor or on a brick frame or steel profile. Based on the fixing solution defined in the installation project, it will be necessary to plan the placement in the base of threaded rods in the expectation that the unit supports can be fixed later on. To do so, it is recommended that a template be made with the heights corresponding to the fixings.



Foresee appropriate damping devices in these fixings to ensure that noise and vibration transmission is avoided (refer to the section "Anchorage for silent-blocks").

- In the event of assembling directly on silent-blocks to the ground, it is recommended that a template of the unit's footprint with the anchoring points of the silent-blocks be made, as described in the previous section.
- With the help of the crane or the forklift truck, the unit will be raised to a sufficient height that the silent-blocks can be screwed into its base. The 4 silent-blocks of the corners must remain oblique and the interiors (if these exist) perpendicular to the unit.
- For each one of the units, certain installation norms must be followed as well:

### Outdoor unit SK

Since it is a unit designed to work outdoors, some specific installation norms must be followed:

- The unit will be placed outside the premises, on a terrace or garden. If it is foreseen that it will work more on heating than on cooling, direct the coil preferably towards the sun. If little work on heating is foreseen, choose North direction.
- Avoid placing obstacles in the air outlet or return. No obstacle may impede the air aspiration into the coil. Do not place the coil side in the predominant wind direction.
- Do not install the unit in a closed enclosure or in conditions that originate air recirculation.

- The chosen location must not flood and must be above the average height the snow reaches in that region.

### Indoor units CK and CP

All indoor units are designed for their indoor installation, connected to a duct network.

Necessary precautions must be taken to prevent the recirculation of air as well as obstructions.

- All models can be installed on the floor or on a brick frame or steel profile. In any case, check that the unit is perfectly level.
- Models 90 through 360 of the CK unit can be attached to the ceiling using the threaded rod:
  - Insert in the framework ceiling 4 threaded rods.
  - Insert the rods through the holes the unit has in its base.
  - Place the antivibration mounts, insert a washer and turn the nuts until the unit is well secured.
  - If there is enough space between the framework and the unit, a rubber or neoprene plate can be squeezed in.
  - Once these operations are finished, a false ceiling can be mounted to hide the unit, leaving a register cover to perform the maintenance and filter cleaning operations.

The filter is mounted on a rail that can be removed from the side or from the base, to replace or clean it.

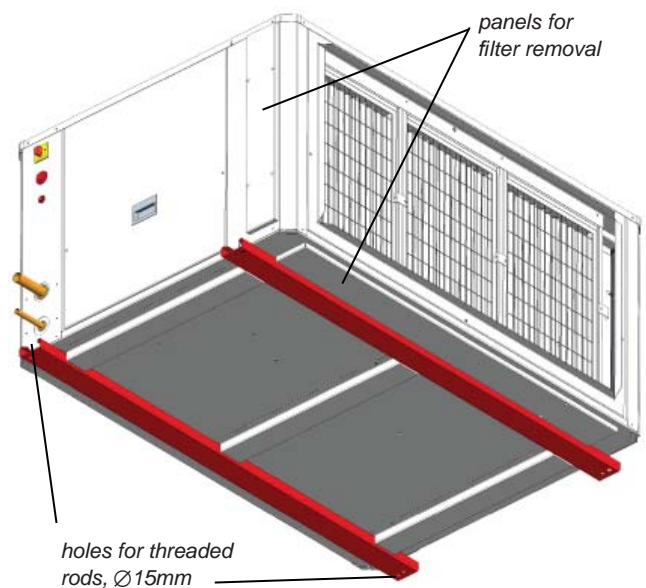

- Also, in case the installation has an air return which is not ducted, appropriately-sized grids must be foreseen in the space formed by the ceiling, the framework and the walls so that the unit aspires the return air from the air conditioned spaces.

### Anchorage for silent-blocks

SK - 90 to 320

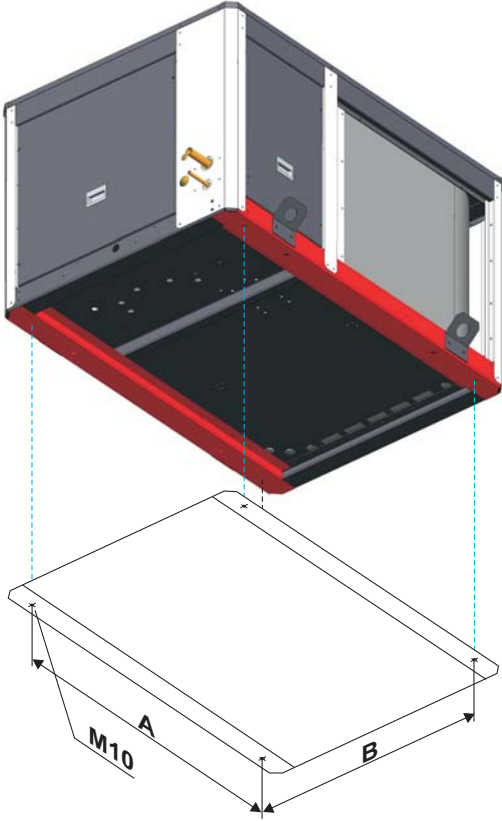

SK - 360 to 600

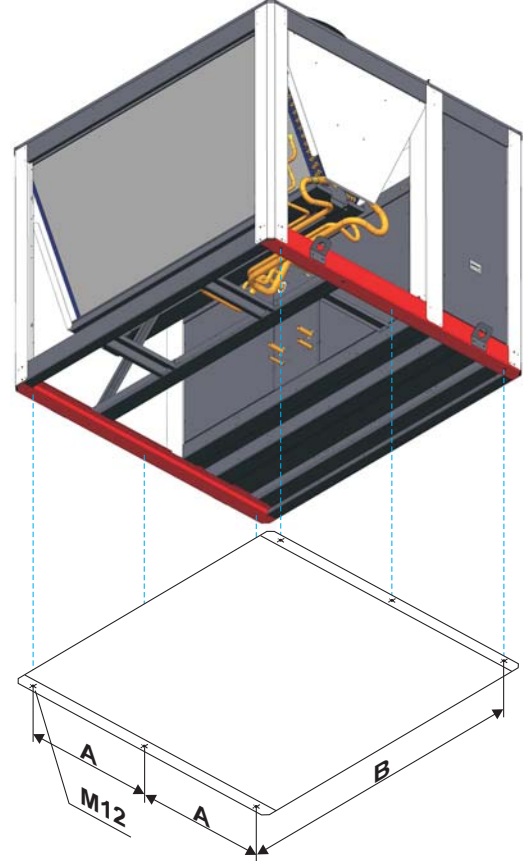

SK	A (mm)	B (mm)
90 to 182	1.257	967
200 to 320	1.557	967
360 to 600	907	2.101

CK - 90 to 360

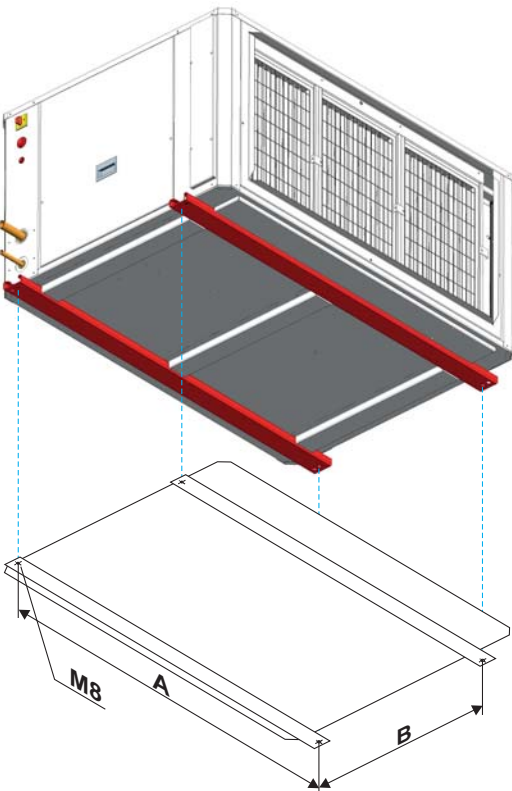

CK - 420 to 600

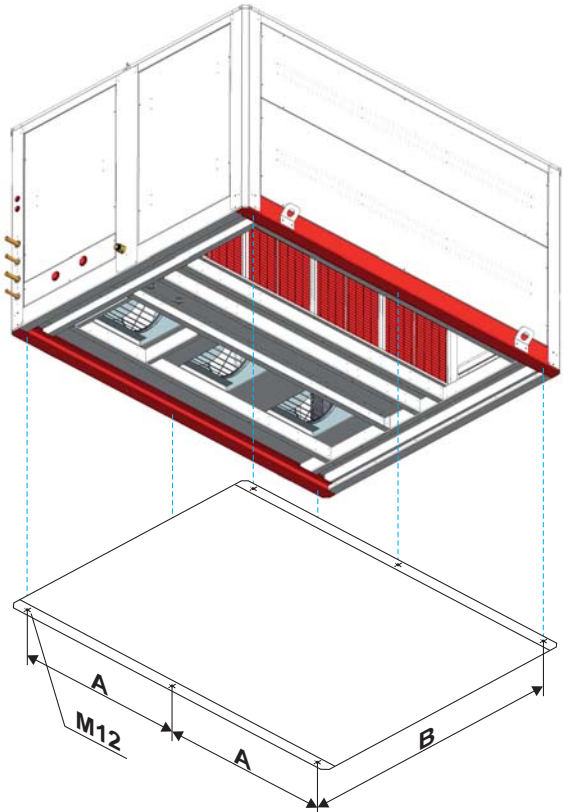

CK	A (mm)	B (mm)
90 to 120	1.146	657
160 and 180	1.476	735
182 to 240	2.100	657
320 and 360	2.760	735
420 to 600	1.300	2.061

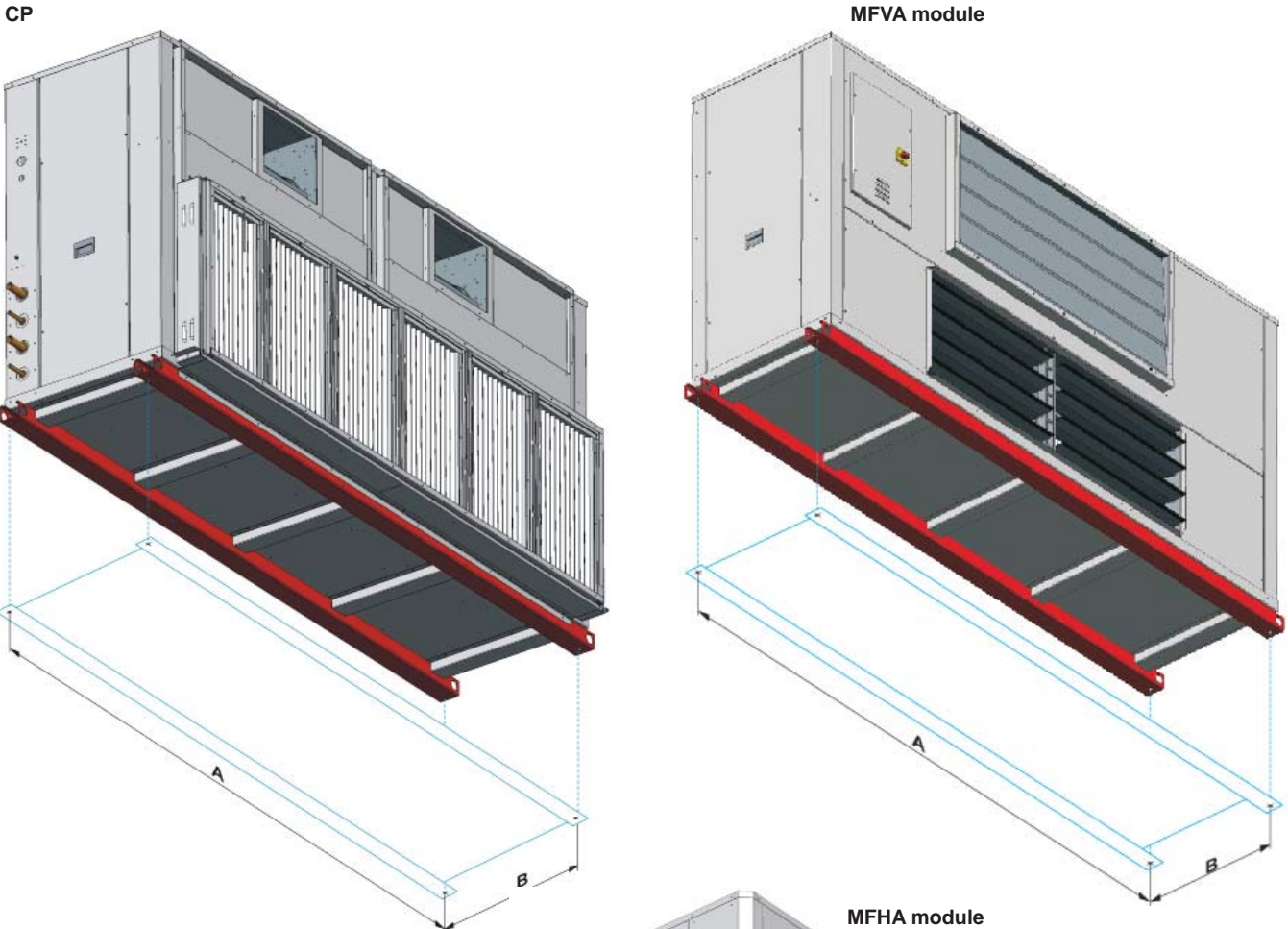

CP	A (mm)	B (mm)	Ø
90 / 100 / 120	1083	613	M8
160	1413	613	M8
182 / 200 / 240	2033	613	M10
320 / 360	2673	613	M10

MFVA module	A (mm)	B (mm)	Ø
182 / 200 / 240	2033	613	M10
320 / 360	2673	613	M10

MFHA module	A (mm)	B (mm)	Ø
90 / 100 / 120	1146	707	M8
160	1476	785	M8
182 / 200 / 240	2100	667	M10
320 / 360	2760	745	M10

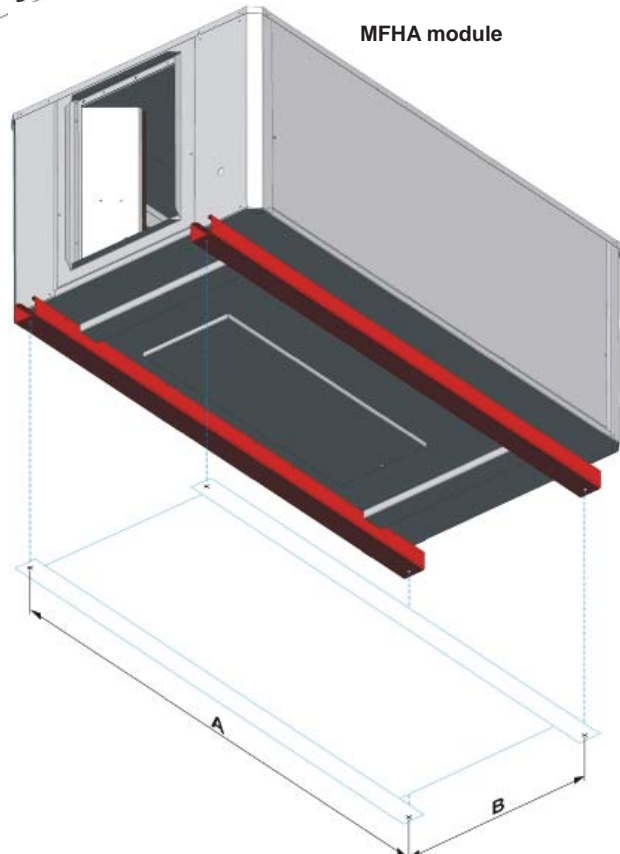

### Minimum free space for commissioning and maintenance operations

SK - 90 to 320

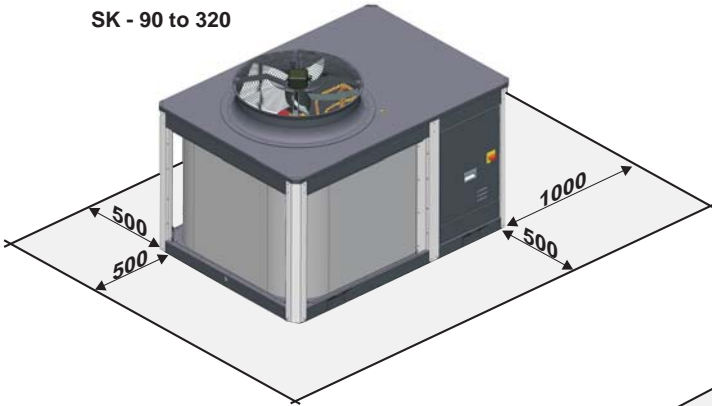

SK - 360 to 600

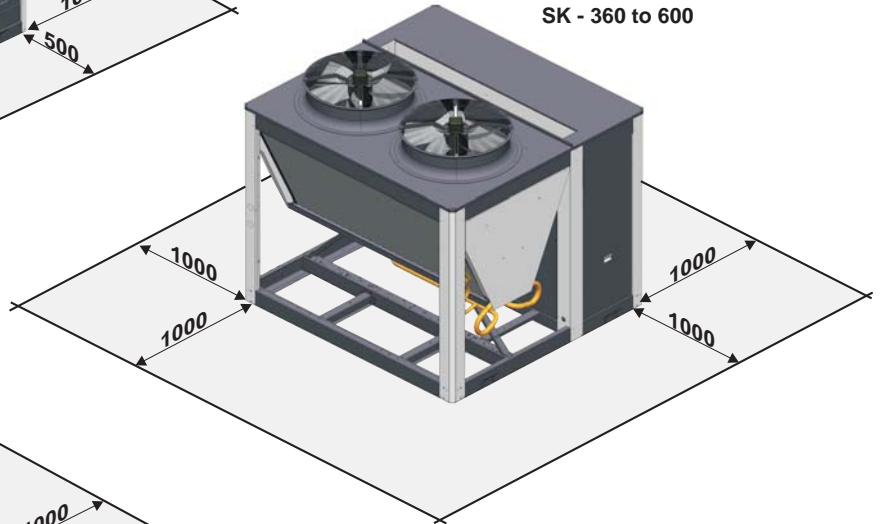

CK - 90 to 360

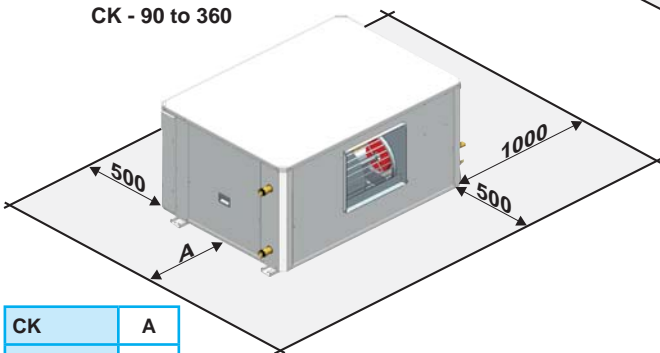

CK - 420 to 600

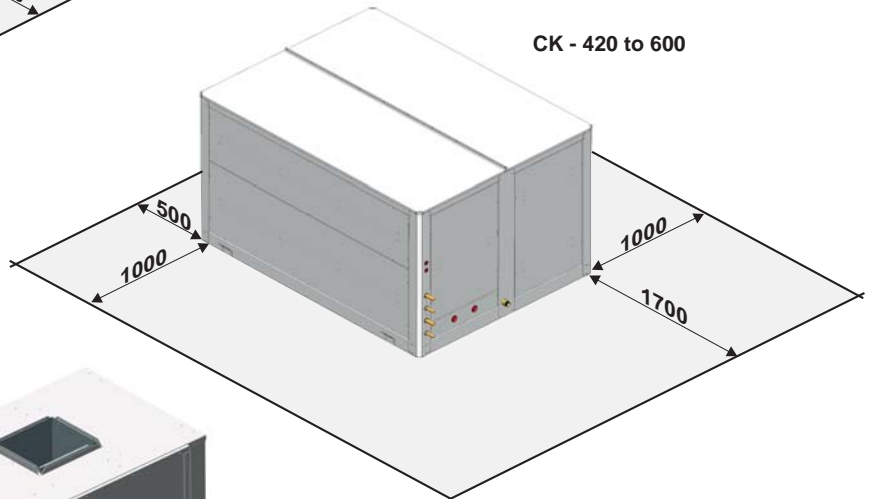

CK	A
90 to 180	250
182 to 360	1000

CP - 90 to 360

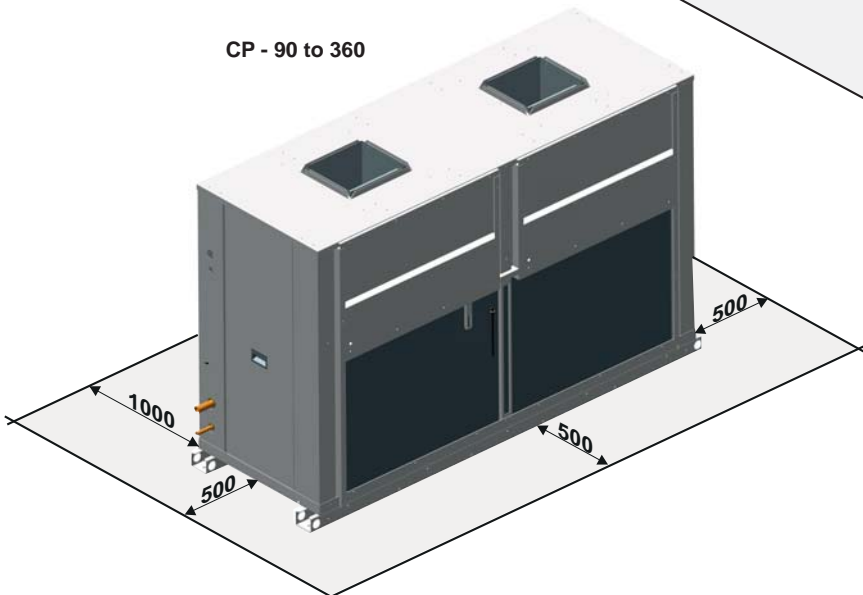





# Split cooling units and heat pumps

## Sound level

These units have been designed to operate with a low sound level. In any case, in the design of the installation, it must be taken into consideration: the outdoor environment for the acoustic radiation, the type of building for the noise transmitted in the air and the solid elements for the vibration transmission. If necessary, a study must be commissioned to an acoustic technician.

### Sound power level on the outdoor unit

SK	90	100	120	160	180	182	200	240	320	360	420	485	540	600
20 Hz	19,2	20,5	33,6	30,8	25,9	25,9	29,8	29,9	33,5	33,4	31,9	32,1	32,2	32,0
25 Hz	21,3	22,3	36,5	33,8	30,0	30,0	33,6	33,3	36,8	36,8	35,7	36,3	36,3	35,8
31,5 Hz	24,9	26,2	39,2	36,3	33,5	33,5	37,1	37,1	39,0	40,8	39,3	39,4	39,4	39,4
40 Hz	29,0	30,1	42,6	39,7	38,3	38,3	42,1	42,3	41,3	46,2	46,3	46,3	46,3	46,0
50 Hz	39,9	40,9	51,5	48,5	49,9	49,9	58,1	58,2	50,4	66,1	65,4	65,8	65,8	65,3
63 Hz	36,3	37,5	53,5	50,7	55,2	55,2	55,0	55,4	55,5	55,0	58,1	57,9	57,9	57,7
80 Hz	40,8	42,2	57,4	54,8	70,2	70,2	67,6	68,1	71,2	65,6	68,6	68,8	68,8	68,6
100 Hz	55,0	56,2	58,8	55,8	56,6	56,6	62,3	62,1	55,1	67,7	64,9	64,9	64,9	64,9
125 Hz	47,5	48,9	56,9	54,4	60,8	60,8	60,1	60,3	58,4	59,4	68,8	68,7	68,7	68,5
160 Hz	50,0	51,2	59,9	57,0	74,3	74,3	71,1	71,0	68,5	67,9	79,0	79,5	79,5	79,2
200 Hz	62,6	63,8	62,3	59,7	69,2	69,2	70,5	70,6	66,8	72,2	78,5	78,9	78,9	78,5
250 Hz	56,8	58,2	65,6	63,0	73,3	73,3	73,2	73,0	70,9	73,0	80,2	79,9	79,9	79,8
315 Hz	60,1	61,5	70,3	67,8	73,9	73,9	75,0	74,9	71,5	76,1	80,3	80,6	80,6	80,4
400 Hz	61,2	62,5	70,4	67,5	76,7	76,7	77,4	77,3	73,5	77,8	81,5	82,0	82,0	81,5
500 Hz	62,2	63,4	71,6	69,0	78,3	78,3	78,6	78,5	77,5	79,2	82,4	82,5	82,5	82,2
630 Hz	63,6	64,7	72,5	69,6	77,8	77,8	77,9	78,2	76,8	78,2	82,4	82,2	82,2	82,2
800 Hz	65,2	66,3	72,7	70,0	78,4	78,4	78,5	78,6	77,2	78,3	82,9	83,0	83,0	82,9
1000 Hz	65,6	67,0	73,4	70,8	80,1	80,1	79,7	79,8	80,0	79,6	83,8	83,8	83,8	83,6
1250 Hz	64,8	66,1	75,1	72,5	78,0	78,0	79,2	79,1	78,8	80,5	81,9	81,9	81,9	81,8
1600 Hz	63,1	64,2	71,3	68,6	74,9	74,9	75,4	75,5	75,2	76,5	79,5	79,7	79,7	79,4
2000 Hz	60,8	62,1	69,5	66,9	74,2	74,2	74,6	75,0	75,3	75,2	77,8	78,1	78,1	77,7
2500 Hz	57,5	58,6	70,1	67,5	71,9	71,9	72,9	72,6	71,6	73,6	75,8	76,1	76,1	75,8
3150 Hz	54,7	56,0	67,2	64,6	69,9	69,9	70,7	71,0	69,7	71,6	73,9	73,6	73,6	73,6
4000 Hz	53,3	54,7	63,3	60,5	68,1	68,1	68,9	69,1	66,8	69,9	70,9	70,8	70,8	70,7
5000 Hz	54,0	55,5	62,2	59,4	65,9	65,9	66,9	67,0	64,4	67,6	67,8	67,6	67,6	67,6
6300 Hz	51,9	53,1	58,5	55,8	62,7	62,7	64,9	64,9	61,8	66,8	66,6	66,6	66,6	66,2
8000 Hz	49,6	51,0	55,5	52,6	59,4	59,4	61,2	61,3	58,4	63,5	63,1	63,3	63,3	62,8
10000 Hz	45,4	46,7	51,3	48,6	56,3	56,3	59,1	59,0	54,7	62,0	58,3	58,5	58,5	58,0
12500 Hz	40,8	42,1	47,0	44,0	51,3	51,3	57,1	57,2	49,7	60,0	52,3	52,4	52,4	52,2
16000 Hz	34,9	36,3	41,4	38,5	45,4	45,4	54,9	54,9	44,7	59,0	46,4	46,5	46,5	46,5
20000 Hz	28,1	29,1	34,3	31,7	37,9	37,9	49,5	49,7	38,1	59,0	39,3	39,4	39,4	39,5
Total dB(A)	74	75	83	80	88	88	88	88	87	89	92	92	92	92

### Sound pressure level on the outdoor unit

Measurement conditions: in free field, measured at a distance of 5 metres, directivity 2 and at 1.5 metres from the ground.

SK	90	100	120	160	180	182	200	240	320	360	420	485	540	600
Total dB(A)	48	49	56	54	62	62	62	62	60	62	65	66	66	65

Note: The sound pressure level depends on the installation conditions and, as such, it only indicated as a guide. Values obtained according to standard ISO 3744.

### Sound power level on the indoor unit

Sound power level in the indoor fan outlet to be taken into account for the silencer calculation:

CK	90	100	120	160	180	182	200	240	320	360	420	485	540	600
Total dB(A)	79	82	80	80	80	82	85	82	83	85	86	87	89	92
CP	90	100	120	160	--	182	200	240	320	360	--	--	--	--
Total dB(A)	79	82	84	84	--	82	85	87	87	89	--	--	--	--

### 11. CHECKING BEFORE COMMISSIONING



**NOTE:** Under no circumstance should the unit be started without having read the brochure completely.

#### Electrical connections

##### Installation norms

To perform the electric installation of the unit (cable glands, conductor section and their calculations, protections, etc.), refer to the information provided in this document (see the technical characteristic table), the electrical scheme included with the unit and norms in effect that regulate the installation of air conditioning units and electrical receivers.

The electric power supply of the unit must be sized in accordance with the maximum power input by the unit taking into account all the options it features (if necessary, refer to the technical brochure).

Verify that electrical power corresponds to the one on the data plate and that the voltage remains constant.



Check that the electrical connections are correct and tight (an electrical diagram is included with each unit, along with its legend).



**Note:** All connections in the site are the responsibility of the installer. These connections are always made as per the current regulation.



To prevent electrical shocks, make all electrical connections before energizing the unit. Check that the automatic switch is closed. Omitting this can cause personal damage. Make the ground connection before any other electrical connection.



The installer must fix line protection elements according to the effective legislation.

#### Electronic control

##### • AVANT / AVANT+

All SK units have an electronic control: AVANT (models 90 to 182) / AVANT+ (models 200 to 600) comprised of a control board and a TCO user terminal.

Optionally, this control can have a terminal for pGD1 maintenance that facilitates the initial scheduling of the unit, the modification of the operating parameters and the description of the alarms produced.

##### Recommendations for the TCO thermostat installation

From the thermostat some of the unit operation aspects are controlled: operation modes, setpoint, differential, timings... Because of this, it is very important to choose an appropriate location within the room since in it is where the unit's control probe is located. This probe must report about the environmental conditions of the occupied area.

The thermostat must be fixed at a height of 1,5 metres from the ground and all possible interferences must be avoided: sun, outdoor air, internal heat sources... Mount the thermostat to the wall using the bracket, do not leave it hanging from the wire or embedding it in the wall.

##### • CIATrtc (optional)

This control is available for all models and is comprised of an electronic control panel and a pGD1 graphic terminal installed over the unit electric panel and accessed using a polycarbonate collapsible window.

Optionally this terminal can be replaced by a TCO user terminal for installation inside of the premises. In this case the TCO terminal

are not allowed to access parameters control and time schedule.

**Note:** Please refer to these control brochures to obtain more detailed information about its operation.

#### Connecting optional devices

Indoor units CK and CP have an auxiliary electric panel for the connection of optional elements in the indoor circuit such as the soft starter, dirty filter pressostat, etc.

##### CK units : models 90 to 360

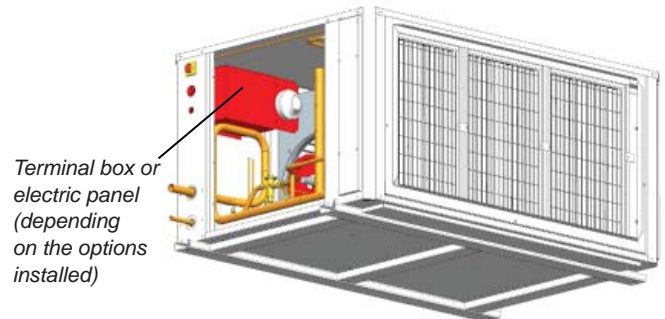

##### CK units : models 420 to 600

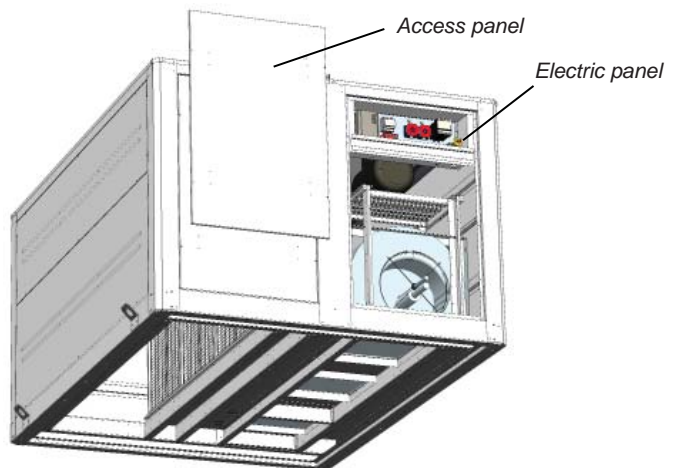

##### CP units

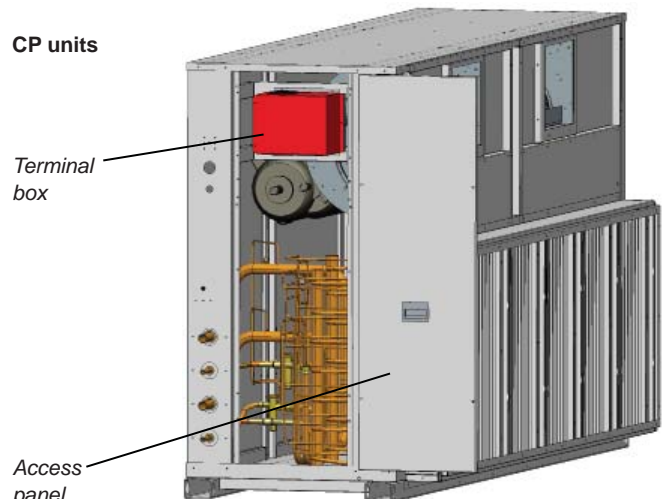

## Connection chart with AVANT (1 stage) and AVANT+ (2 stages) electronic control and indoor unit CK

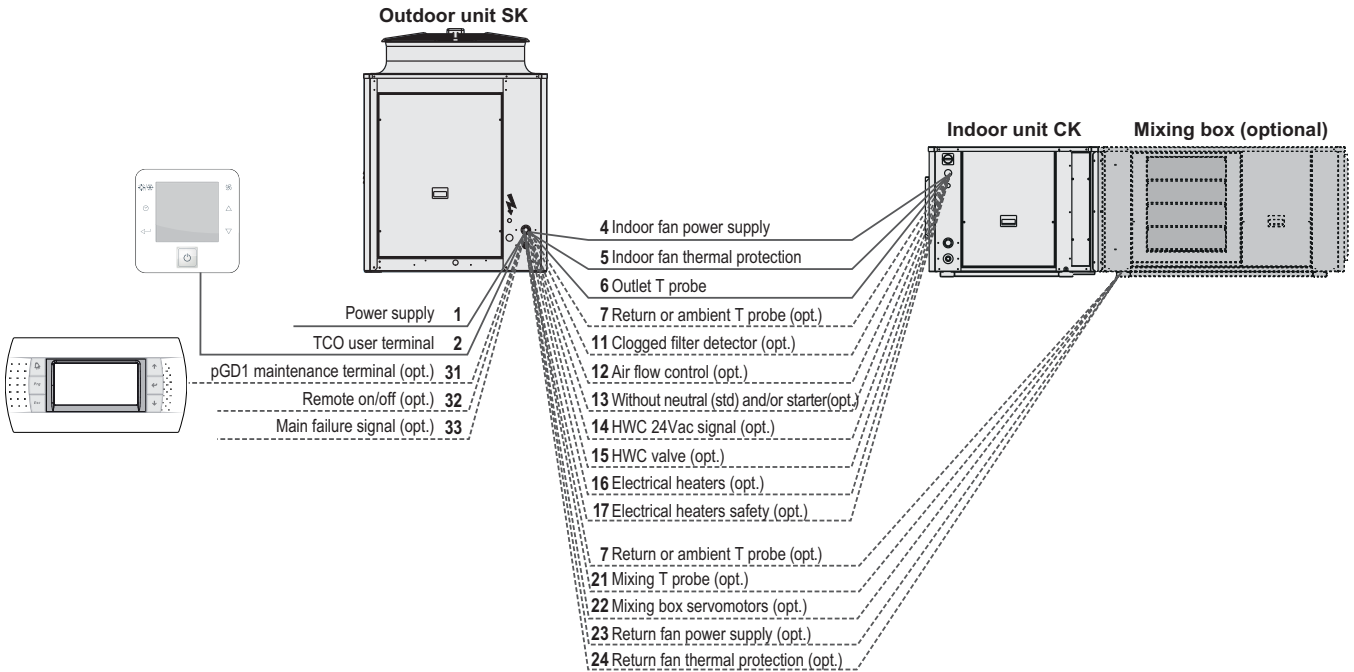

No.	SK	90	100	120	160	180	182	200	240	320	360	420	485	540	600
1	Power supply	400 III (±10%)		3 + GND											
2	TCO user terminal connection ①	2 wires for power supply 230V + 1 shielded cable for communication type AGW20 / 22 (1 braided pair + drainwire + shielding)													
4	Indoor fan power supply	3 + GND													
5	Thermal relay signal of the indoor fan	2 wires													
6	Outlet temperature probe	2 wires													
7	Return or ambient temperature probe (optional) ②	2 wires													
11	Clogged filters detector (optional)	2 wires													
12	Air flow control (optional)	2 wires													
13	Unit without neutral (std) and/or soft starter (opt.)	1 wire													
14	HWC 24 Vac signal (optional)	2 wires													
15	HWC valve (optional)	1 wire													
16	Electrical heaters (optional) ③	3 wires (per stage) + GND													
17	Safety thermistors of electrical heaters (optional)	2 wires													
21	Mixing temperature probe (optional) ②	2 wires													
22	Mixing box servomotors power supply (optional) ②	3 wires													
23	Return fan power supply (optional) ②	3 + GND													
24	Thermal relay signal of the return fan (optional) ②	2 wires													
31	pGD1 maintenance terminal connection (optional)	telephone cable 6 wires standard (RJ12 connector)													
32	Remote on/off (optional)	2 wires													
33	Main failure signal (optional)	2 wires													

① If the unit is going to be installed in an industrial environment with a high level of electromagnetic interference, it is recommended to shield the cables of the thermostat control.  
 ② In indoor units with the optional mixing box, these connections are realized directly between the outdoor unit and the terminal board of the box mentioned  
 ③ The power supply for the electrical heater must be protected by an automatic switch and/or fuses to be foreseen by the installer.

### Connection chart with AVANT (1 stage) and AVANT+ (2 stages) electronic control and indoor unit CP

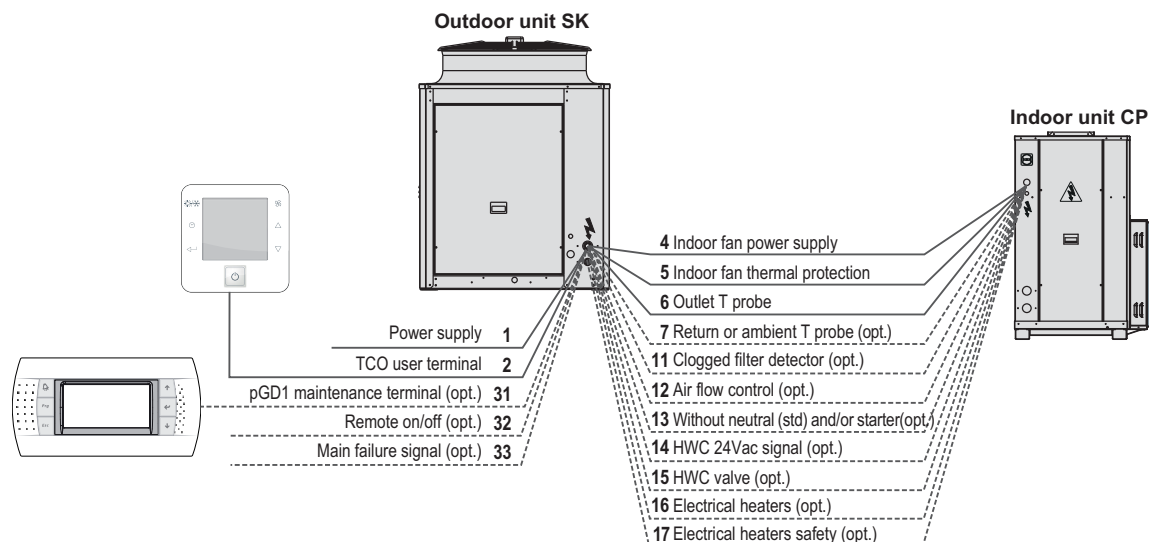

No.	SK	90	100	120	160	182	200	240	320	360
1	Power supply	400 III (±10%)	3 + GND							
2	TCO user terminal connection ①	2 wires for power supply 230V + 1 shielded cable for communication type AGW20 / 22 (1 braided pair + drainwire + shielding)								
4	Indoor fan power supply	3 + GND								
5	Thermal relay signal of the indoor fan	2 wires								
6	Outlet temperature probe	2 wires								
7	Return or ambient temperature probe (optional) ②	2 wires								
11	Clogged filters detector (optional)	2 wires								
12	Air flow control (optional)	2 wires								
13	Unit without neutral (std) and/or soft starter (opt.)	1 wire								
14	HWC 24 Vac signal (optional)	2 wires								
15	HWC valve (optional)	1 wire								
16	Electrical heaters (optional) ③	3 wires (per stage) + GND								
17	Safety thermistors of electrical heaters (optional)	2 wires								
31	pGD1 maintenance terminal connection (optional)	telephone cable 6 wires standard (RJ12 connector)								
32	Remote on/off (optional)	2 wires								
33	Main failure signal (optional)	2 wires								

① If the unit is going to be installed in an industrial environment with a high level of electromagnetic interference, it is recommended to shield the cables of the thermostat control.

② In indoor units with the optional mixing box, these connections are realized directly between the outdoor unit and the terminal board of the box mentioned

③ The power supply for the electrical heater must be protected by an automatic switch and/or fuses to be foreseen by the installer.

## Connection chart with CIATrtc electronic control (optional) and indoor unit CK

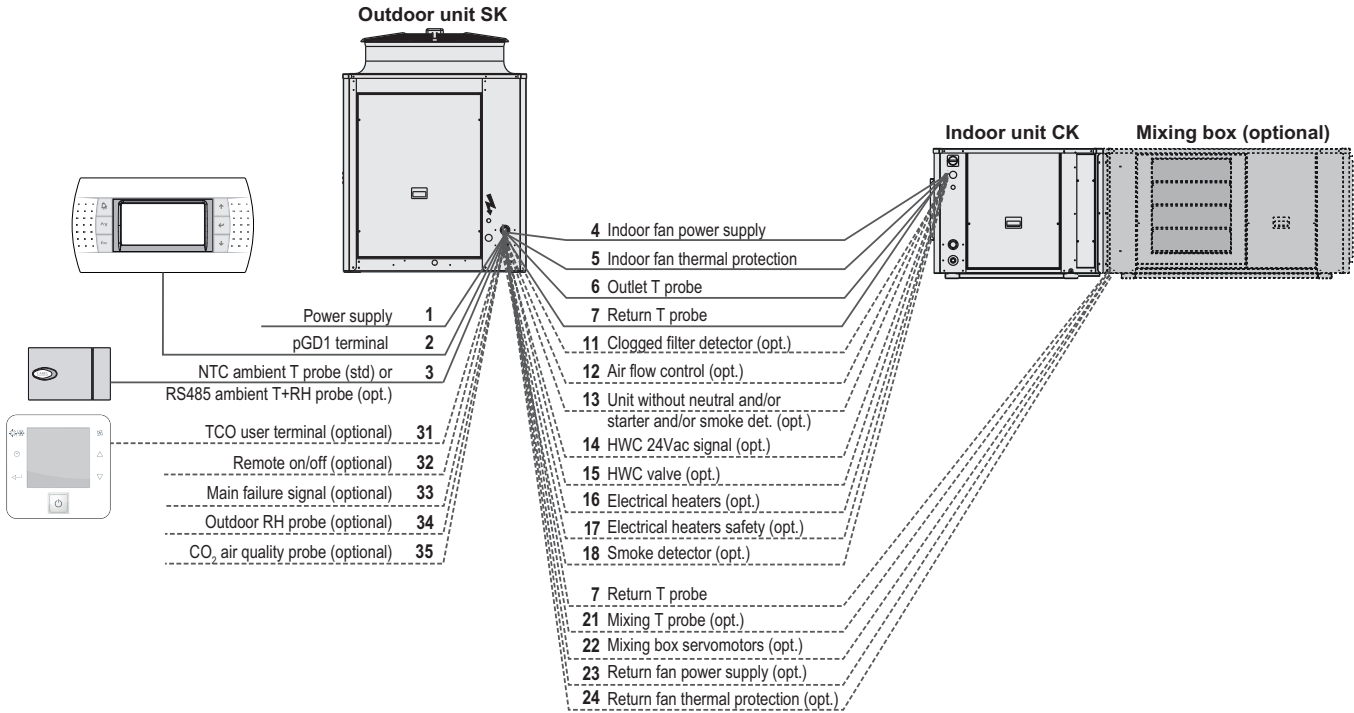

No	SK	90	100	120	160	180	182	200	240	320	360	420	485	540	600
1	Power supply	400 III (±10%)		3 + GND											
2	pGD1 terminal connection	telephone cable 6 wires standard (RJ12 connector)													
3	Ambient T probe (std) or RS485 ambient T+RH (opt.)	2 wires (std) / 5 wires (RS485)													
4	Indoor fan power supply	3 + GND													
5	Thermal relay signal of the indoor fan	2 wires													
6	Outlet temperature probe	2 wires													
7	Return or ambient temperature probe (optional) ②	2 wires													
11	Clogged filters detector (optional)	2 wires													
12	Air flow control (optional)	2 wires													
13	Unit without neutral (std), soft starter and/or smoke detector (opts)	1 wire													
14	HWC 24 Vac signal (optional)	2 wires													
15	HWC valve (optional)	1 wire													
16	Electrical heaters (optional) ③	3 wires (per stage) + GND													
17	Safety thermistors of electrical heaters (optional)	2 wires													
18	Smoke detector (optional)	2 wires													
21	Mixing temperature probe (optional) ②	2 wires													
22	Mixing box servomotors power supply (optional) ②	3 wires													
23	Return fan power supply (optional) ②	3 + GND													
24	Thermal relay signal of the return fan (optional) ②	2 wires													
31	TCO user terminal connection (optional) ①	2 wires for power supply 230V + 1 shielded cable for communication type AGW20 / 22 (1 braided pair + drainwire + shielding)													
32	Remote on/off (optional)	2 wires													
33	Main failure signal (optional)	2 wires													
34	Outdoor RH probe (optional)	3 wires													
35	CO <sub>2</sub> air quality probe (optional)	3 wires													

① If the unit is going to be installed in an industrial environment with a high level of electromagnetic interference, it is recommended to shield the cables of the thermostat control.

② In indoor units with the optional mixing box, these connections are realized directly between the outdoor unit and the terminal board of the box mentioned

③ The power supply for the electrical heater must be protected by an automatic switch and/or fuses to be foreseen by the installer.

### Connection chart with CIATrtc electronic control (optional) and indoor unit CP

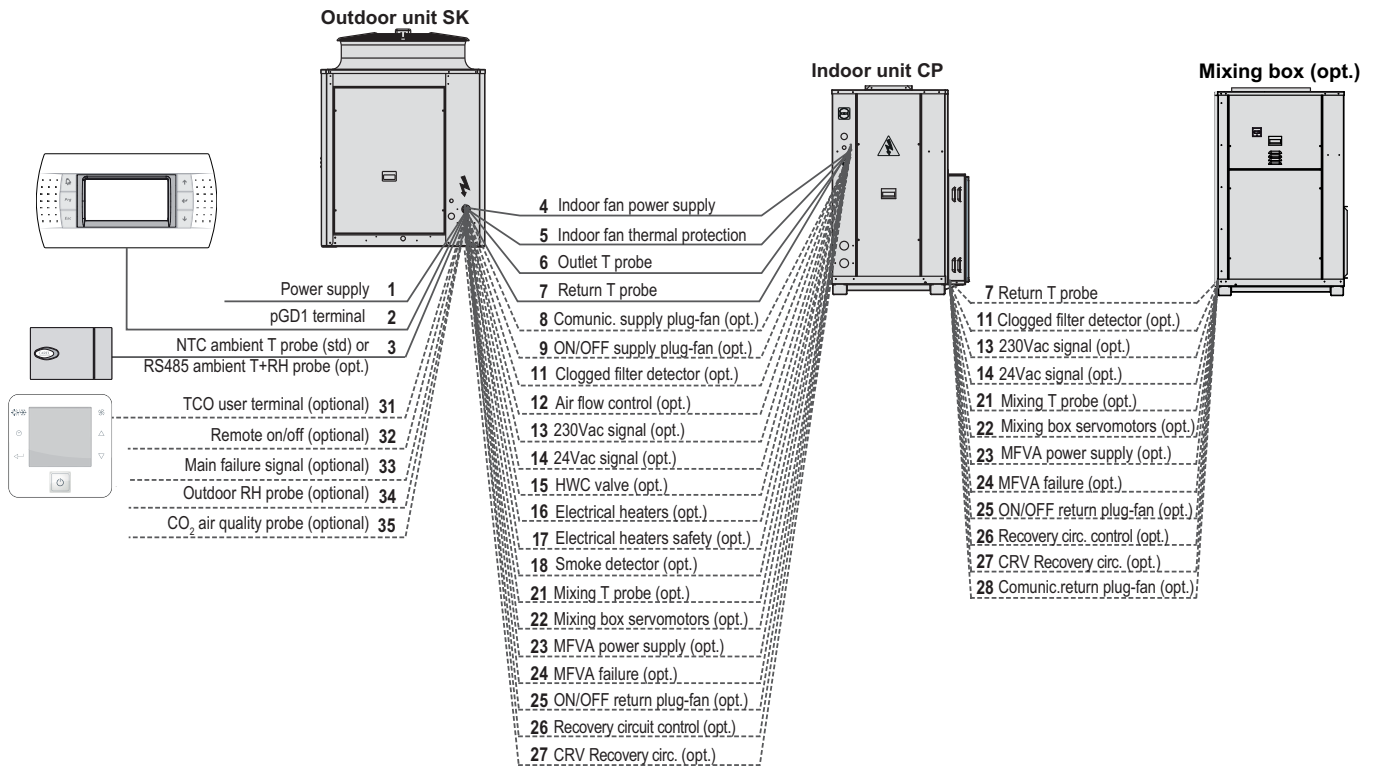

No	SK	90	100	120	160	182	200	240	320	360
1	Power supply	400 III (±10%)								
2	pGD1 terminal connection									
3	Ambient T probe (std) or RS485 ambient T+RH (opt.)									
4	Indoor fan power supply									
5	Thermal relay signal of the indoor fan									
6	Outlet temperature probe									
7	Return or ambient temperature probe (optional)									
8	Communication with supply plug-fan (optional)									
9	ON/OFF supply plug-fan (optional)									
11	Clogged filters detector (optional)									
12	Air flow control (optional)									
13	230 Vac signal (optional)									
14	24 Vac signal (optional)									
15	HWC valve (optional)									
16	Electrical heaters (optional) ②									
17	Safety thermistors of electrical heaters (optional)									
18	Smoke detector (optional)									
21	Mixing temperature probe (optional)									
22	Mixing box servomotors power supply (optional)									
23	MFVA power supply (optional)									
24	MFVA failure (optional)									
25	ON/OFF return plug-fan (optional)									
26	Recovery circuit control (optional)									
27	Cicle reversing valve of recovery circuit (optional)									
28	Communication with return plug-fan (optional)									
31	TCO user terminal connection (optional) ①									
32	Remote on/off (optional)									
33	Main failure signal (optional)									
34	Outdoor RH probe (optional)									
35	CO <sub>2</sub> air quality probe (optional)									

① If the unit is going to be installed in an industrial environment with a high level of electromagnetic interference, it is recommended to shield the cables of the thermostat control.

② The power supply for the electrical heater must be protected by an automatic switch and/or fuses to be foreseen by the installer.



# Split cooling units and heat pumps

## Condensate drain connection

### Outdoor unit SK

#### Models 90 to 320 (coil in U)

These units can optionally have an indoor condensate drain pan.

The pan has a drain tube of outer diameter of 22 mm to which a PVC or transparent plastic tube must be connected for draining the condensates.

This pan is standard in units with centrifugal fan (optional) (set up a siphon).



#### Models 360 to 600 (coil in V)

These units are equipped with two condensates pans located in the lower part of the two coil sides.

These pans drains have a drain tube of outer diameter of 22 mm, to which a PVC or transparent plastic tube must be attached for the condensate draining that reaches the bottom of the unit.

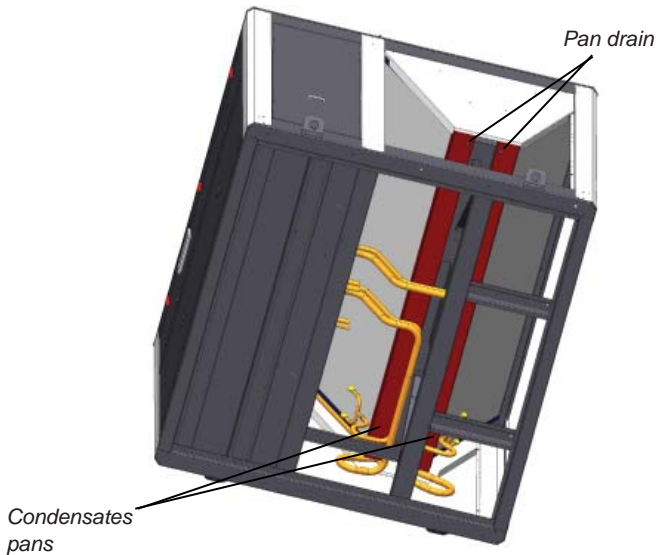

### Indoor unit CK

#### Models 90 to 360

These indoor units are equipped with a condensate drain pan, with a bronze, gas threaded 3/4" M drain junction.

**CONNECT SIPHON  
METTRE SIPHON  
PONER SIFON**  
V220014

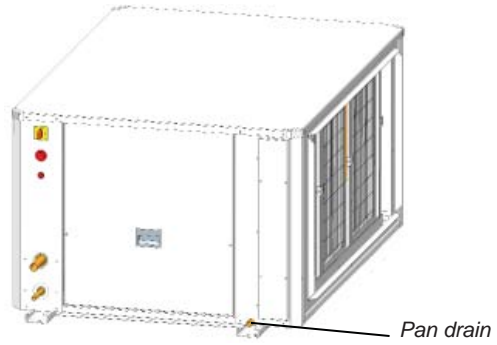

#### Models 420 to 600

These indoor units are equipped with a junction for the draining of the condensate drain pan, made of bronze, gas thread 1 1/4" M.

**CONNECT SIPHON  
METTRE SIPHON  
PONER SIFON**  
V220014

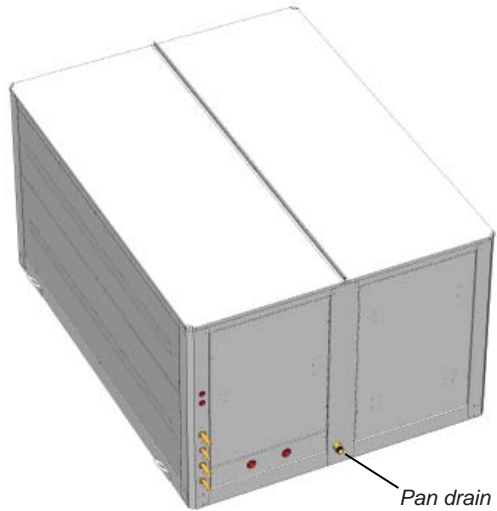

### Indoor unit CP

These indoor units are equipped with a junction for the draining of the condensate drain pan, made of bronze, gas thread 7/8" M.

**CONNECT SIPHON  
METTRE SIPHON  
PONER SIFON**  
V220014

When CP unit is coupled to a MFVA module with recovery circuit (MRC000 assembly), this module incorporates its own pan, gas thread 7/8 "M.

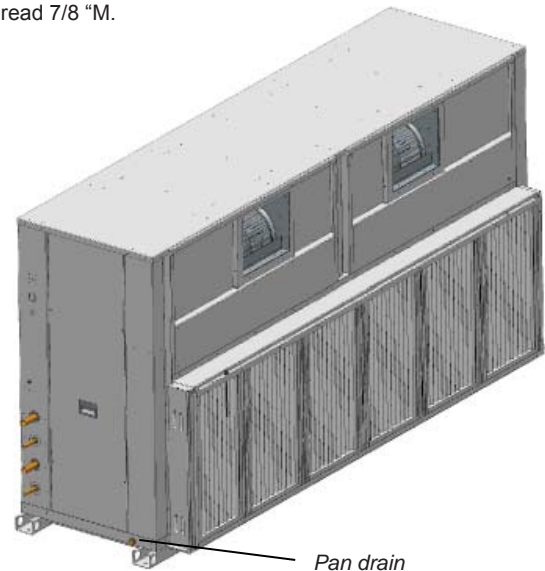

### Siphon installation norms

All water drain tubes must be provided with a siphon to avoid bad smell and water spills.

#### Pan in overpressure:

- It's installed to avoid the access through the drain piping of bad smells.

#### Pan in underpressure:

- Besides the above application, water must be suctioned from the pan because of the depression with respect to the motorfan assembly.
- Perform the siphon assembly as per the scheme of the attached starting diagram:
  - For the correct siphon design, the "A" height must be at least twice that of the underpressure (mm.w.c) where the condensate pan is placed.
  - Check that the condensate outlet is not clogged.
  - The drain piping must be slightly sloped to ease circulation towards the drain.
  - The original diameter of the piping must be respected. No reduction can be made.
  - In the case of units installed outdoors, with outdoor temperatures which are lower than 0°C the necessary precautions must be taken to prevent the water in the drain piping from freezing.

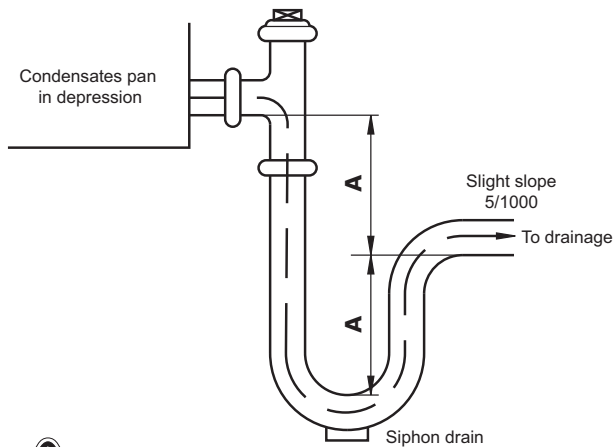

Check the watertightness of the connection.

- Before commissioning, check the blade rotation direction and that the axis turns without strokes nor vibrations.
- Once running, check the operation conditions: pressures, flows and consumptions.
- With electronic fans (optional), check that they adapt their rotational speed based on the condensation or evaporation pressure.

### Checks in the centrifugal fans

- Before commissioning, check the blade rotation direction and that the axis turns without strokes nor vibrations
- Once running, check the operation conditions: pressures, flows and consumptions.
- The overlapping of characteristic curves of the fan and the room is very important, so that the flows and pressures provided to the duct network are as required.

**ACHTUNG:** VOR DER ÖFFNUNG DIESER PANEEL STROM ABSCHALTEN UND 2 MIN. WARTEN.

**WARNING:** BEFORE OPENING THIS PANEL SWITCH OFF THE ELECTRIC SUPPLY AND WAIT FOR 2 MIN.

**ATTENTION:** AVANT L'OUVERTURE DE CE PANNEAU COUPER L'ALIMENTATION ÉLECTRIQUE ET ATTENDRE 2 MIN.

**ATTENZIONE:** PRIMA DE APRIRE QUESTA PARETE INTERRUPERE L'ALIMENTAZIONE ELETTRICA E ASPETTARE 2 MIN.

**ATENCIÓN:** ANTES DE ABRIR LA PUERTA CORTAR LA ALIMENTACIÓN ELÉCTRICA Y ESPERAR 2 MIN.

V220086

### Checks in the axial fans

**WARNING:** MUST WEAR SAFETY HELMET. BEFORE OPENING THIS PANEL, SWITCH OFF THE ELECTRIC SUPPLY AND WAIT 2 MIN.

**ATTENTION:** PORT DU CASQUE OBLIGATOIRE. AVANT L'OUVERTURE DE CE PANNEAU COUPER L'ALIMENTATION ÉLECTRIQUE ET ATTENDRE 2 MIN.

**ATENCIÓN:** USO OBLIGATORIO DE CASCO. ANTES DE ABRIR LA PUERTA, CORTAR LA ALIMENTACIÓN ELÉCTRICA Y ESPERAR 2 MIN.

2062180

#### • Soft starter detail (optional):

Soft starter of the supply and/or return centrifugal fans which prolongs the set time mainly aimed at installations with cloth ducts. Compulsory for motors with an output of 15 kW and above.

For motors up to 15kW it is installed in the factory in the auxiliary electric panel. For larger motors it is installed next to the ventilation group.

#### Motor output up to 15 kW



#### Motor greater than 15 kW





## Pulley and belt calibration

**Attention:** Before performing these operations, it is necessary to verify that the unit is disconnected from mains.

Centrifugal motorfans are coupled with pulleys and belts.

In this type of fans, the following must be taken into consideration:

- The pulleys must be on the same plane, so it is important to check them with the help of a ruler or a laser aligner.
- In case they are not aligned, remove the pulley screws, remove the pulley and, after removing the taper pin, it can be slid over the axle (this action can be performed both in the motor as well as in the fan).
- After fixing the pulleys on the same plane, the belt tension is made by tightening the tensor screw.
- The belt tension must be checked after 24 hours of motor operation.

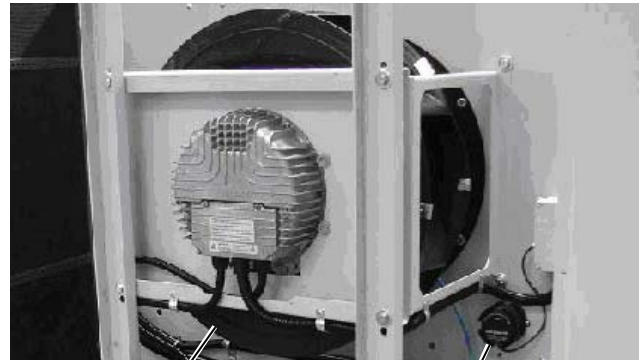

Plug-fan

Flow control pressostat

Pulleys must stay on the same plane

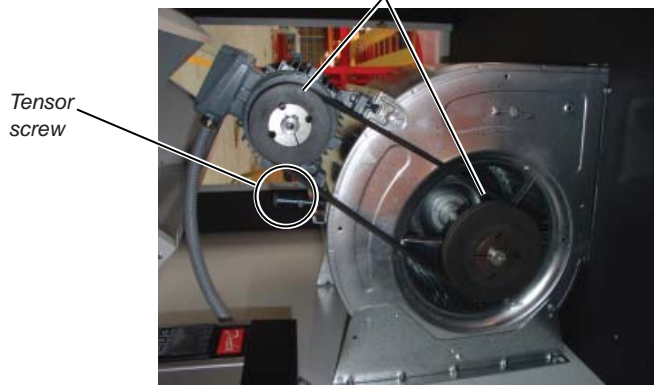

Tensor screw

Pulley screws



Taper pin

## Checks in plug-fans (optional)

- Electronic plug-fans with variable speed and flow sensor that can be incorporated in:
  - Supply: CK y CP.
  - Return: CK (models 420 to 600) and CP (models 182 to 360).
- The coupling of characteristic curves of the fan and the room is very important, so that the flows and pressures provided to the duct network are as required.
- The variable-speed plug-fans have a flow control pressostat. This pressostat comes from the factory adjusted to the indicated flow.
- it is possible to readjust the flow for different conditions, on site, by means of the on the pGD1 terminal (see the specific brochure of the CIATrctc control, mandatory with this type of fans).

## Air ducts connections

The air supply and return ducts must be calculated in accordance with the rated flow and the unit's available pressure (refer to the technical characteristics table). The duct calculation and design must be made by qualified technical personnel.

It is advisable to take into consideration the following recommendations:

- Curves in the fan supply outlet(s) must be avoided. It is recommendable to have a straight section of duct measuring approximately 1 metre. If it is not possible, they must be as smooth as possible, using indoor deflectors when the duct is of large dimensions.
- When making the ducts, direction sharp changes must be avoided since they can generate occasional pressure drops, which affect the available pressure and the flow. The location of discharge and aspiration grilles must be studied carefully to avoid the air recirculation and the transmission and generation of noises to the interior.
- Flexible connections must be made between the ducts and the unit that avoid the noise and vibration transmission.
- No matter the type of ducts type to use, these must be insulated and not be composed of materials that propagate fire nor expel toxic gases in the event of a fire. The internal surfaces must be smooth and should not pollute the air that circulates within them. In any case, the effective legislation about this issue must be respected.



**Caution:** Indoor units are designed to connect to a duct network. In the event that the outlet fan of the indoor circuit is accessible from a particular point in the duct network, the installer must install a protection mesh in the discharge as per the current regulation.

## Cooling connections

Once installed the outdoor and indoor units, the cooling links must be laid between them.

La maximum equivalent length of the cooling line is 50 metres, with a maximum geometric height of 40 metres when the outdoor unit is high (for longer distances an oil separator must be used per cooling circuit). If it is the indoor unit which is high, the maximum equivalent length is reduced to 7 metres.

### Outdoor unit top

Maximum equivalent length of the cooling line: 50 metres  
For longer lengths an oil separator must be user

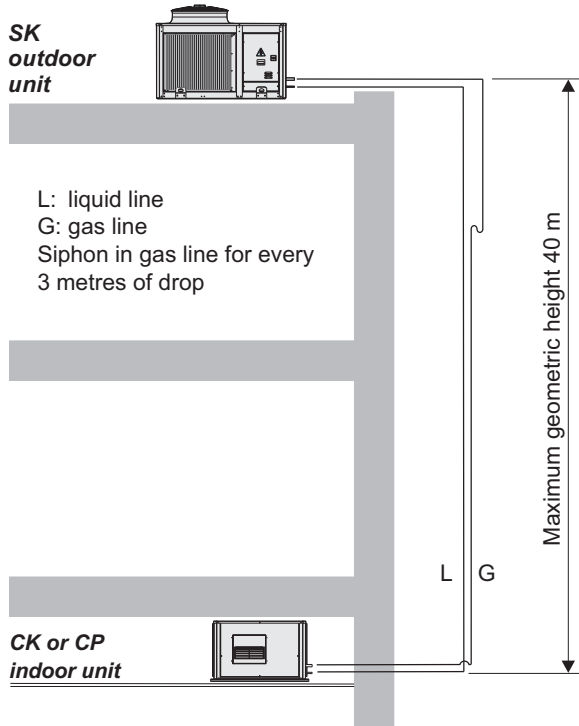

### Outdoor unit bottom

Maximum equivalent length of the cooling line: 7 metres

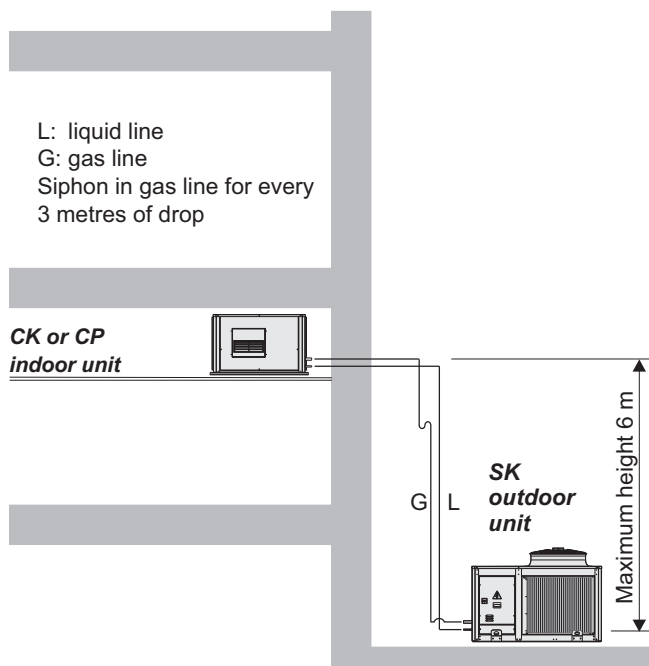

It is recommended to place a siphon in the gas line every 3 meters of shoulder to ease the oil return to the compressor.



For determining the equivalent length, the pressure drops in accessories must be taken into account.

### Pressure drops in elbows expressed as equivalent lengths (m):

Tube installation norms must be respected and inspect carefully the tube lay out, looking for the shortest distance and the lowest possible number of curves. Also, chokes must be avoided, using large curve radii (the curve radius must be  $\geq 3,5 \times \varnothing$ ).

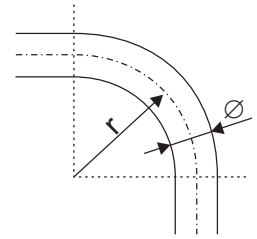

Tube diameter (inches)	1/2"	5/8"	7/8"	1 1/8"
Equivalent elbow length 45° (m)	0,24	0,30	0,39	0,48
Equivalent elbow length 90° (m)	0,45	0,54	0,72	0,90
Equivalent elbow length 180° (m)	0,75	0,80	1,00	1,30

### Connection of the unit to the cooling lines

For the refrigerant lines, use only cooling type seamless tubes. Under no circumstance use sanitary type copper pipe.

Following these steps is recommended:

- Revise and clean the tube ends to eliminate the burrs from cutting them and any other impurity that could have deposited inside or on the outer surface. How clean the tubes are will dictate the degree or air tightness. Also, we will avoid the dirt formation that may collapse some spots in the cooling circuit.
- Apply isolator to the piping, covering them and affix it with tape. The material used must guarantee the air tightness at operation pressure and temperature.
- Remove the plugs that protect the cooling connections of the unit precisely at the moment of connecting the tubes.
- Align precisely both parts of the connection (unit and piping). There is no error risk when both tubes have different diameters.
- Run a pressure test in the cooling tubes and a search for leaks to verify the cooling installation.
- Create a vacuum in the installation to eliminate humidity inside the circuit.
- Charge the unit with gas as per the data stated in the technical characteristic table. Add the refrigerant slowly via the schrader valve built into the liquid line of each circuit, whilst the compressor is in operation, monitoring the pressures to detect if there are any possible anomalies.
- If the equivalent length of the cooling lines is over 7 m, an additional charge will be needed per meter as per the following table.

Nominal diameter (")	1/4"	3/8"	1/2"	5/8"	3/4"	7/8"	1"	1 1/8"
Indoor section (cm²)	0,149	0,444	0,900	1,505	2,282	3,120	4,290	5,346
Liquid line charge (g/m)	19,3	57,0	115,0	193,5	292,3	404,1	550,3	685,7
Gas line charge (g/m)	-	0,2	0,4	0,7	1,0	1,4	2,0	2,5

**Note:** To ensure that the gas charge is correct, when performing the "unit operation verification" the subcooling of the liquid must be checked.

## 12. SAFETY ELEMENTS

### Low pressure pressostat

When connected to the compressor suction, it will stop its operation when the pressure at that point goes down below the tare value (caused by obstructions in the circuit, excessive dirt in the filters, fan stop or ice formation in the evaporator).



This pressostat disconnects at 2 bar and is automatically reactivated.

### High pressure pressostat

Connected to the compressor discharge, it will stop its operation when the pressure at that point reaches the setpoint. It disconnects at 42 bar and it is automatically reactivated.



### Safeties at the compressor

The scroll type compressor that these units as standard have the following safeties:

- Non-return valve built into the compressor.
- Temperature probe for the discharge from the compressor to protect the unit with discharge temperatures greater than 135°C.

### Main door switch

By using a mechanical device, it impedes access to the electric panel when the unit is with voltage.

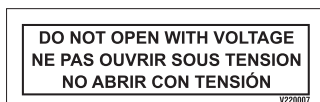

### Magnetothermals for line protection

They are located at the beginning of the power lines for the compressors and motor fan(s) to protect them.

### Automatic switch in the control circuit

Magnetothermal switch that protects the operation circuit against continuous surges as well as against high currents of short duration (short circuits).

### Defrost control

This safety device is intended to eliminate ice which could accumulate in the outdoor coil when the unit is working in the heating cycle. Defrosting is carried out by the control depending on the value measured by the sensor(s) on the outdoor coil(s) and the time set between defrosting operations.

### Condensation and evaporation pressure control

This safety device, integrated in the control, enables managing the outdoor fan(s) when the units are working in cooling mode with low outdoor temperatures (condensation control) or in heating mode with high outdoor temperatures (evaporation control). This aids the unit's operation in all the seasons.

In the case of EC electronic fans (optional), speed control will be proportional based on the average pressure measured by the pressure transducer(s) in the outdoor coil(s).

### Protection of the electric panel (optional)

Electrical heater for protecting the components of the electric panel.

### Anti-fire safety

With the optional return air probe, the electronic control can activate an anti-fire safety device that detains the unit when the return air surpasses a temperature of 60°C (by default). It cannot return to operation until the temperature has dropped to below 40°C.

### Control of air flow (optional)

- For those units with centrifugal supply fans (standard), a differential pressostat can be incorporated in order to measure the variation in air flow. This pressostat allows the detection of fan belt breakages, since the fan relay only detects operating faults that have arisen in the motor. This safety device is included in units with electrical heaters. This pressostat is installed in the factory in the auxiliary electric panel of the indoor unit.
- The supply plug-fans (optional) adapt their speed to the average flow measured by the differential pressure sensor and the value set as a setpoint in the electronic control.

### Clogged filter detector (optional)

Differential pressostat for indication, through an automatic reset alarm, of a level of dirtiness of the filters greater than the established level. Automatic reset.

Pressure reading is done thanks to two intakes within the air flow before and after the filter, such that a comparison is made between the pressure of the inlet air to the filter (positive) and the outlet air of the same to the other side of the evaporating coil (negative).



This pressostat is installed in the factory in the auxiliary electric panel of the indoor unit or in the auxiliary electric panel of the MFVA module, that can be coupled to the CP unit.

### Smoke detector (optional)

In accordance with standard NF S 61-961, this smoke detection station uses a LED to indicate the installation status, and if the probe detects the presence of smoke in the installation, it stops the operation of the unit.

The station is installed in the factory in the main electric panel (CP units and models 320 to 600 of CK units) or in the auxiliary electric panel (models 90 to 240 of CK units).

Smoke detecting probe



### Refrigerant leak detector (optional)

The gas detector sensor is a device that signals leaks in refrigerant. When the loss of a certain concentration is detected, the sensor sends the alarm to the control, which stops the unit and locally activates a acoustic and visual signal.

This offers the advantage of acting immediately to gas leaks, guaranteeing the safety of persons who are in the proximity thereof. Its installation complies with European regulations F-GAS, EN378, and ASHRAE 15.

This sensor is installed next to the supply fan. In case of alarm, it is reset manually.



### Air quality probe (optional)

This probe is installed in the environment and allows for the measurement of CO<sub>2</sub> and/or volatile compounds and improves the management of air renewal.

This probe is to be connected by the client. The clamps on the terminal board on the main panel used for the connection are indicated on the wiring diagram provided with the unit.

This probe is supplied inside the main electric panel.

## 13. OPTIONAL



The installation of some of these options brings in pressure drops at air level therefore this must be considered when selecting fans. the pressure drop graphs in the options, can be seen in the technical brochure.

### Mixing box (CK and CP)

In the CP unit, as well as in models 90 to 360 of the CK unit the mixing box is a separate module. The link between them is made with the M8 screws and rivet nuts provided from factory.

**Note:** all available assemblies indoor units with mixing boxes can be found in Chapter 4.

#### Models 90 to 360 of CK units with MS and MC modules

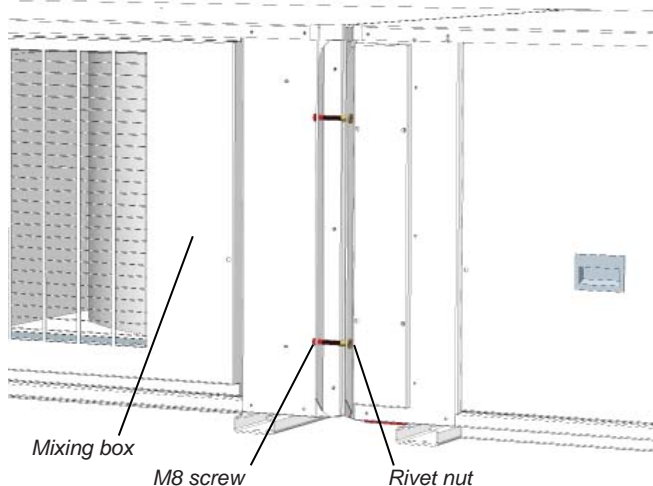

Note: the electrical connection of the mixing box (MS or MC) is performed from the electric panel of the outdoor unit SK. Please, refer to the corresponding "Chart of electrical connection" in section "Electrical connection".

#### CP units with MFHA module

The joining between the box and the unit is done via 3 M8 screws, by each side, and the rivet nuts supplied from factory.

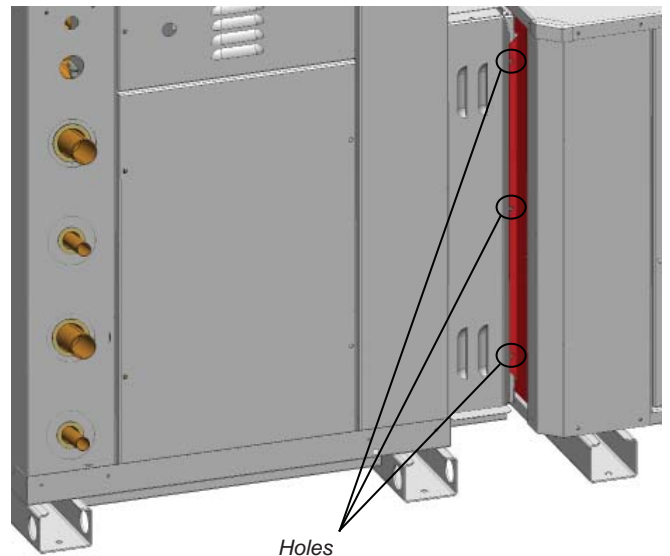
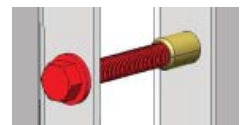

Note: the electrical connection of the mixing box (MFHA module) is performed from the terminal box located on a pillar inside the indoor unit CP. Please, refer to the corresponding "Chart of electrical connection" in section "Electrical connection".

### CP units with MFVA module

The joining between the box and the unit is done via 3 M8 screws, by each side, and the rivet nuts supplied from factory.

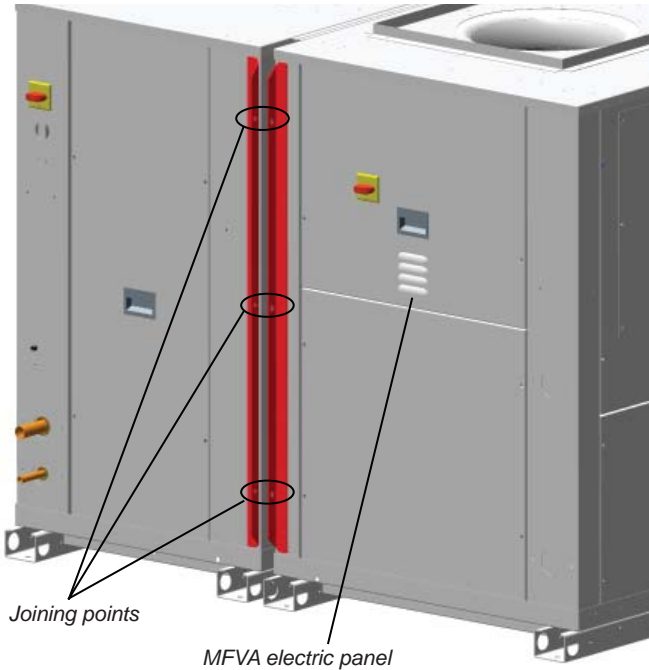

Note: the electrical connection of the mixing box (MFVA module) is performed from the terminal box located on a pillar inside the indoor unit CP. Please, refer to the corresponding "Chart of electrical connection" in section "Electrical connection".

Note: The frame with filters is located inside the MFVA module (see the section "Filters" in this chapter).

### Recovery circuit in MFVA module (MRC000 assembly)

This module can incorporate a complete cooling circuit dedicated to recovery, with independent control, adapted to the air renewal requirements.

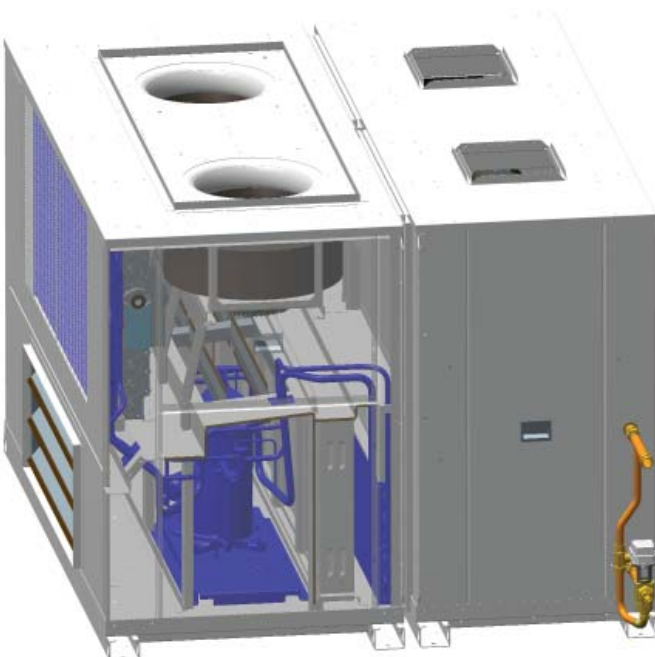

### Supply plenum (CP)

Supply plenum with punched or double deflection grille, which allows air to be discharged through either side.

The joining between the plenum and the unit is done via self-tapping screws.

Note: Upper supply of the CP unit is mandatory with this plenum.

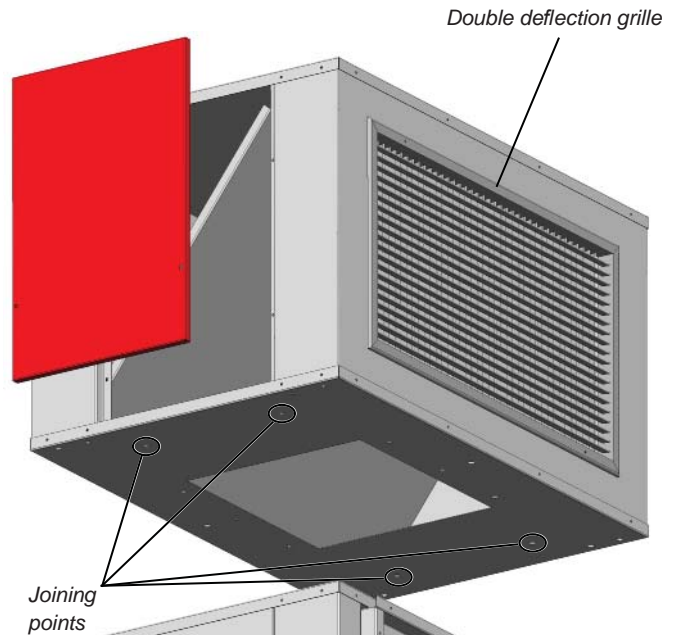

Joining points



Joining points

### Electrical heaters (CK and CP)

- The auxiliary electrical heaters are ready for operation in two power stages. In the case of two indoor units with the one outdoor unit the assembly of the support is not possible in two stages (each indoor unit is equivalent to 1 stage).
- The electrical heaters acquired with the unit will be incorporated to it modifying the electric panel in the factory, so that it is compatible with the electronic control.
- The electrical heaters requested for units already shipped will be sent in a kit, and the installer will need to assemble the elements required for the operation of the unit and for compliance with the legal regulations that are applied to the modified unit with regard to safety.

### Electrical heaters in models 90 to 360 of indoor unit CK

In these models, the connection is made at the fan outlet:

- In models 90 to 120 each of the rows of electrical heaters has an output of 1 kW. As from model 160, the output of each row will be 2 or 3 kW according to the total output.
- In models with two supply fan outlets (two frames), as well as in the case of 1 supply outlet with 2 rails, the electrical heaters are distributed as symmetrically as possible between both frames.

Frame for assembly of the auxiliary heater in the supply fan outlet:

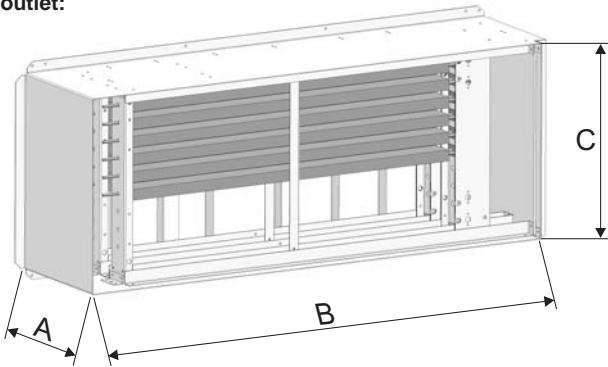

CK	Total output (kW)	Dimensions (mm)		
		A	B	C
90 / 100 / 120 (1 supply outlet)	6 / 9 (1 row)	150	482	443
	12 (2 rows)	262	482	443
160 / 180 (1 supply outlet)	12 / 15 / 18 (1 row)	189	1.142	443
182 / 200 / 240 (2 supply outlets)	15 / 18 (1 row)	189	1.142	443
	24 / 30 / 36 (2 rows)	297	1.142	443
320 / 360 (2 supply outlets)	15 / 18 / 24 / 30 / 36 (1 row)	189	1.142	443

**Note:** in models with centrifugal return fan it is not possible to assemble electrical heaters with outputs of 30 and 36 kW.

### Access for maintenance:

The frame has access designed from the right side for maintenance. In the case of 2 frames (2 supply outlets) are placed symmetrically so that the electrical heaters can be taken out without problems, that is, one will be accessed from the right and the other one from the left.

To access the electrical heaters, the 2 screws that fasten the frame side panel must be unscrewed as shown in the following image:



Access panel

In order to remove the electrical heaters the power supply cables must be disconnected from the terminal board and the hose taken out.



Safety thermistors

Electrical heaters

Hose

Then, unscrew the screw that fastens the electrical heaters' frame and take out by the rail, as shown in the following images.



Rail





# Split cooling units and heat pumps

### Kit assembly:

When the frame with the electrical heaters is provided in a kit, follow the steps below for connecting it:

Step 1: lay down the frame on the panel to set the hole locations that will fix said frame to the panel. Another hole must also be drilled to connect the hose to the electric power supply.

CK	A	B	C	D	E	F	G	H	I	J	K	L	M	N
90 / 100	648	946	145	443	60	165	482	299	217	204	320	128	476	43
120	648	946	113	443	92	115	482	349	167	204	370	96	476	75
160 / 180	648	1276	46	443	158	81	1142	53	133	356	75	30	476	142
182 / 200	648	1900	161	443	44	379	1142	379	430	356	400	146	476	27
240	648	1900	133	443	72	379	1142	379	430	356	400	116	476	55
320 / 360	711	2560	108	443	160	58	1142	160	79	356	264	91	476	143



Step 2: fasten the frame to the panel with self-tapping screws.



If it is not possible to perform the previous step, the distance between holes, as well as the frame dimensions, are displayed in the following schemes:

CK - 90 / 100 / 120

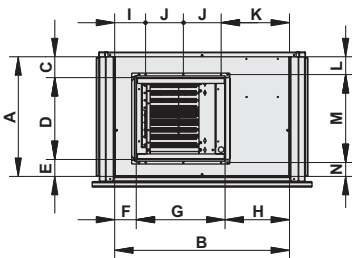

CK - 160 / 180 / 182 / 200 / 240

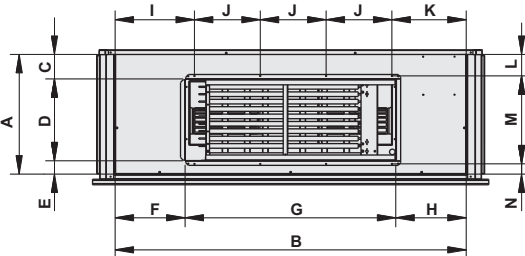

CK - 320 / 360

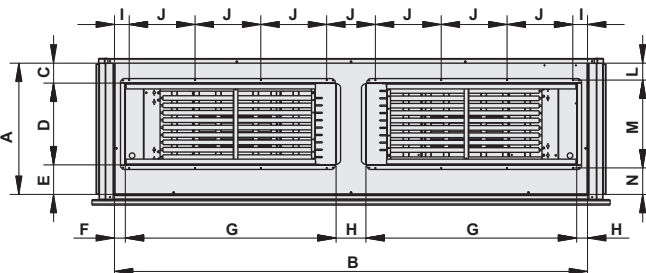

Step 3: insert the hose through the drill made for the connection to the indoor electric panel of the unit.

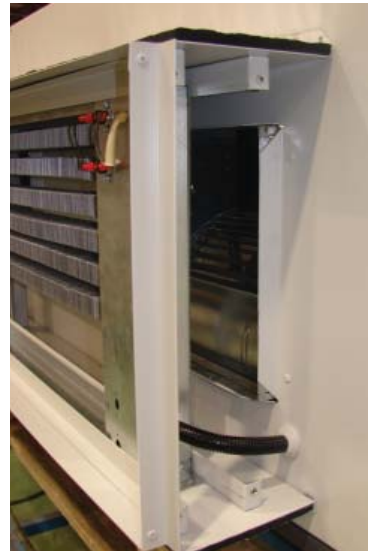

Note: The connection of the necessary elements for the adequacy to the handling of the unit must be performed by the installer.

Step 4: close the access panel. The outlet is ready for ducting.

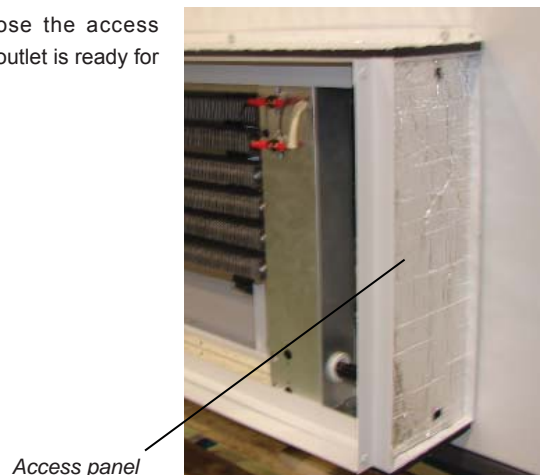

### Electrical heaters in models 420 to 600 of indoor unit CK

Assembly and connection inside the unit.

#### Kit assembly:

When the frame with the electrical heaters is provided in a kit, follow the steps below for connecting it:

Step 1: the electrical heaters are sent divided into 2 or 4 frames, depending on the required power, as shown in the following table:

Total output (kW)	36	45	54	72
Stage power (kW)	18 + 18	18 + 27	27 + 27	36 + 36
CK - 420 / 485	2 frames			--
CK - 540 / 600	--	2 frames		4 frames

To attach these frames to the unit, four supports are provided. In the case of 2 frames, screw each one of them to 2 supports with the four M4 screws included in the kit.

The height of the frame on the support will depend on the position of the supply fan, since it should never be behind the fan volute.

For example, in the following diagram, the frame location will be valid for lower and side supply.

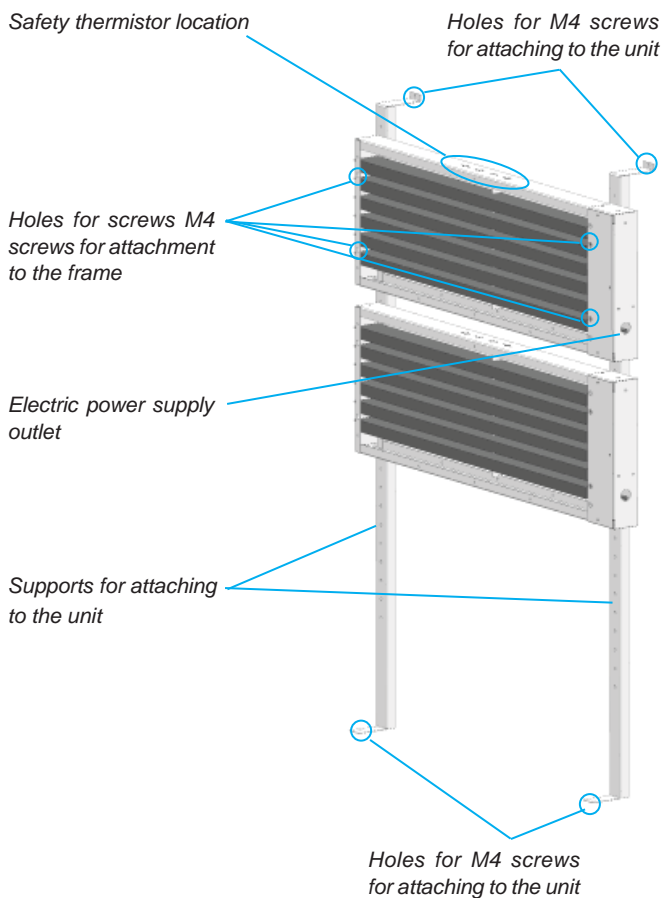

Step 2: attach the supports with the frames linked inside the unit. To that extent, drills have been made in the unit to which the supports must be screwed.

Supports attached to the unit

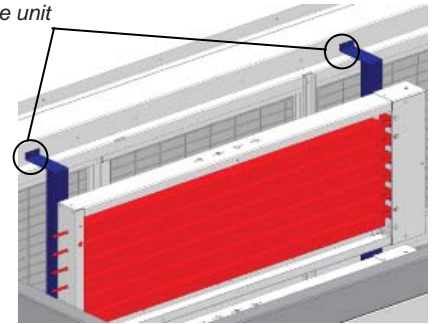

The supports attached to the unit can be seen in the following illustration.

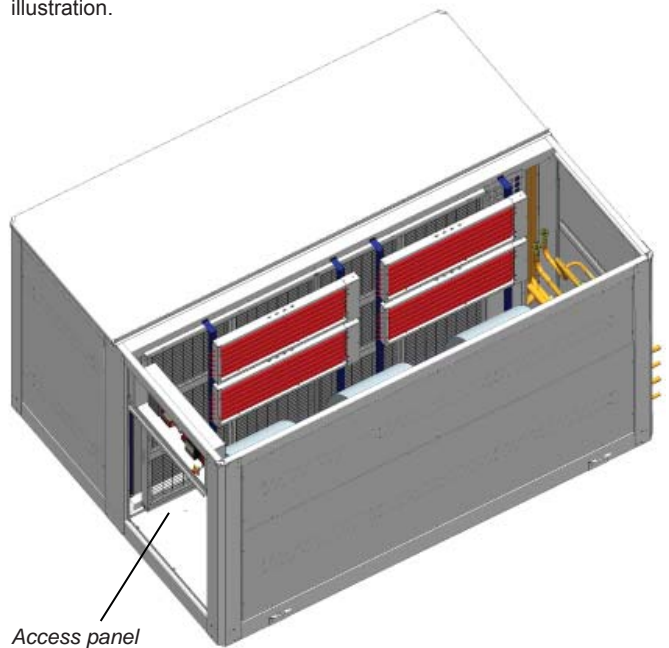

Step 3: take the hoses with the electric power supplies to the indoor electric panel of the unit.

Note: The connection of the necessary elements for the adequacy to the handling of the unit must be performed by the installer.

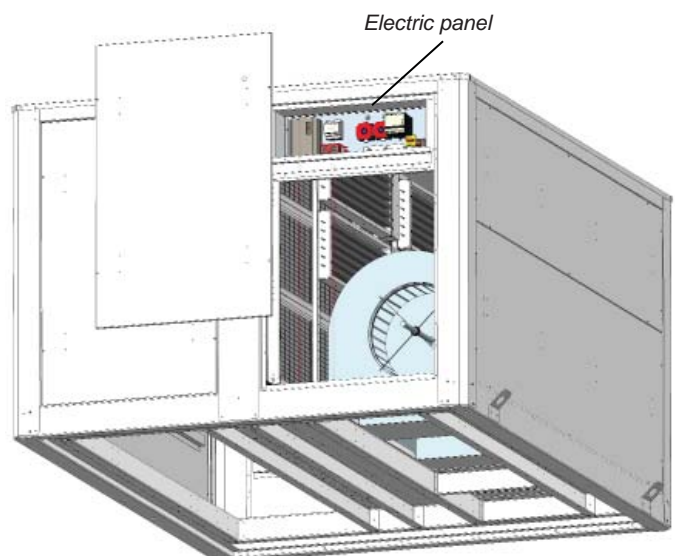



## Electrical heaters in indoor unit CP

Assembly and connection inside the unit.

### Kit assembly:

When the electrical heaters are provided in a kit, follow the steps below for connecting them:

The electric heaters are sent divided into one frame or shared between two frames based on the required power:

Total output (kW)	6	9	12	15	18	24	30	36
Stage power (kW)	3+3	3+6	6+6	6+9	9+9	12+12	15+15	18+18
No. of frames	1 frame				2 frames			

Step 1: The frame(s) will be placed next to the coil, as shown in the image below, and will be attached to the lower profile via two M4 screws.

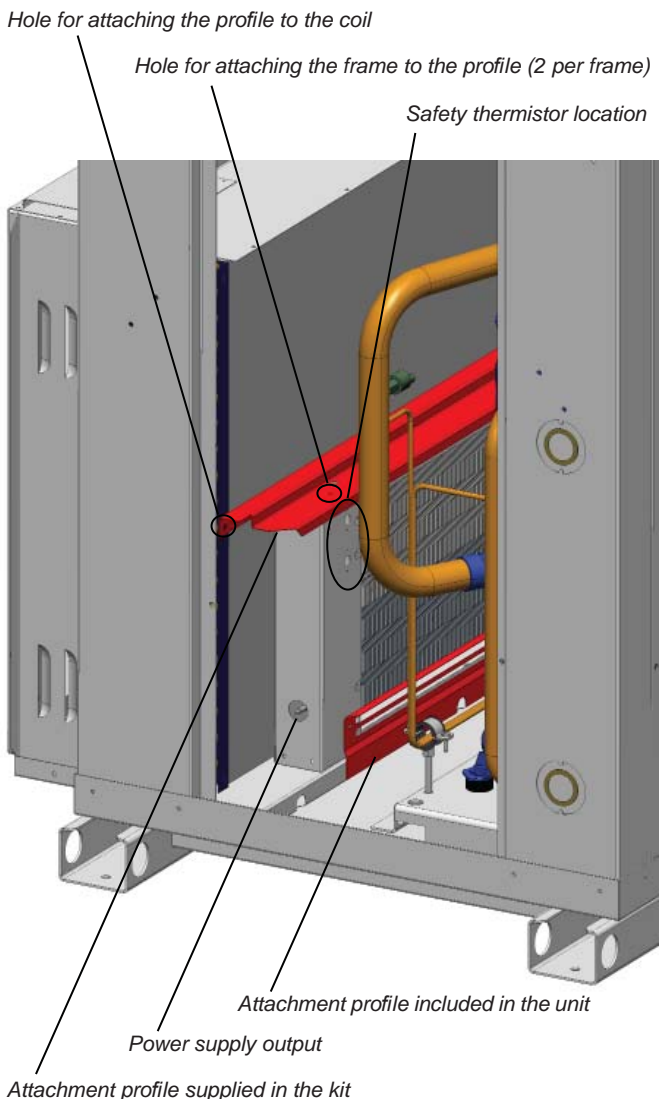

- Step 2: Next the frame(s) will be installed onto the upper profile, supplied in the kit, via two M4 screws.
- Step 3: This profile will be attached to the air coil via two M4 screws.
- Step 4: Finally, take the hoses with the electric power supplies to the unit's electric panel.

## Hot water coil (CK and CP)

Hot water coil for mounting inside the unit, with a 3-way valve managed by the unit's electronic control. In the case of CP unit, this valve will be mounted outside of the unit.

Two types of water coils are availables:

- Nominal coil for heating in cooling-only units (CK).
- Auxiliary coil for heating in heat pump units. In this case the air inlet temperature matches the air outlet temperature of the indoor coil (CK and CP).

**Note:** in CK unit, with stop-drop in the indoor air coil it is not possible to assemble the hot water coil

**Note:** check position and dimensions of input/output of the coil in the technical brochure of this series.

### Models 90 to 360 of CK units

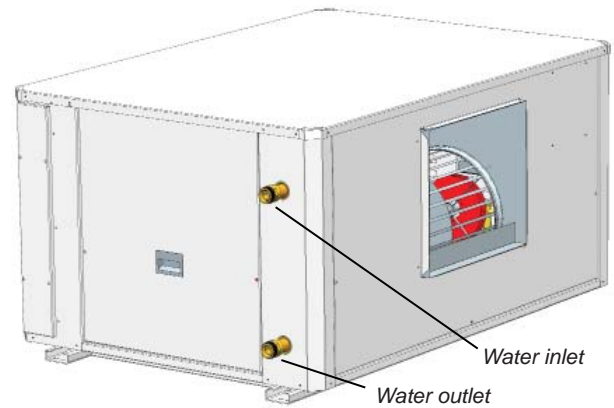

### Models 420 to 600 of CK units

The inlet/outlet connections of the hot water coil are located inside the unit. The connection can be established via the unit base using flexible sleeves or via the side panel. The sheet precut positions are indicated in the below drawing.

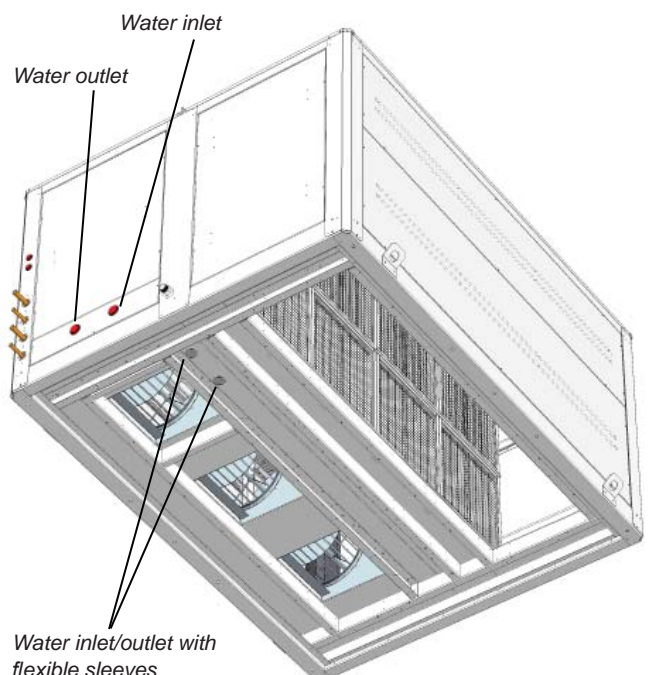

### CP units

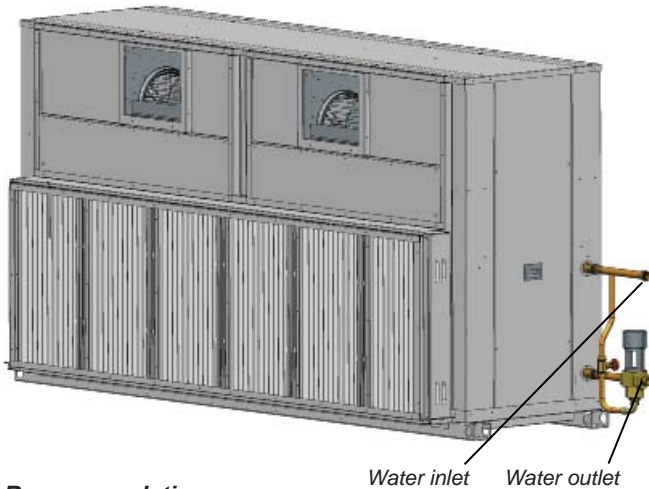

#### Recommendations:

- Coil filling:
  - The coil filling must be made with the bleeder valve open until water runs through it, which is when it is time to close it.
  - Cut off the water supply and let the bubbles generated go up to the highest coil point, which is the same as the bleeder valve, and eliminate by opening the purger.
  - Pour more water into the circuit and repeat the previous steps.
  - Activate the water pump (to be foreseen by the installer) and repeat the previous steps until no air noises are heard in the piping, which is when the filling of the installation will have been finished successfully.
- In case of long unit stops, and forcibly if they happen in the winter season, the coil must be emptied.
- Possible water freezing must be avoided: glycoling water or by using anti-freeze thermostat that triggers the 3-way valve.

Note: this thermostat is mandatory if the unit is installed outdoors, as well as in cases in which it uses free-cooling and works outside at negative temperatures.

- The direction of the water flow must be correct and so the following indications must be observed:



### Stop-drop (CK)

Stop-drop in the indoor air coil and at the outdoor air intake.

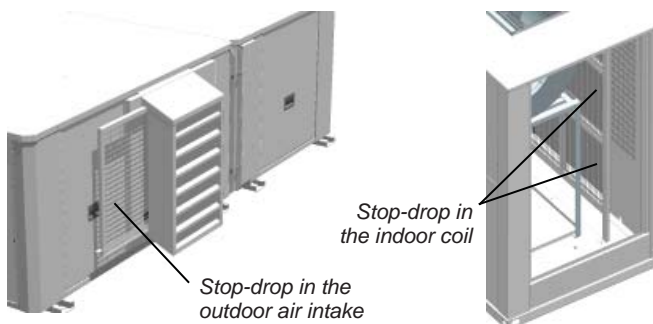

**Note:** with hot water coil (nominal or heater) it is not possible to assemble the stop-drop.

### Filters (CK and CP)

All model types can substitute the filtering mesh that the units include regularly with G4 rating, mounted on the same frames. Creased opacimetric filters classified F6 to F9 can also be added.

#### Indoor unit CK

For taking out the filters, both the frames with the gravimetric filters as well as opacimetric frames (if the unit has includes them) are assembled over a sheet steel profile.

#### Models 90 to 360 of CK units

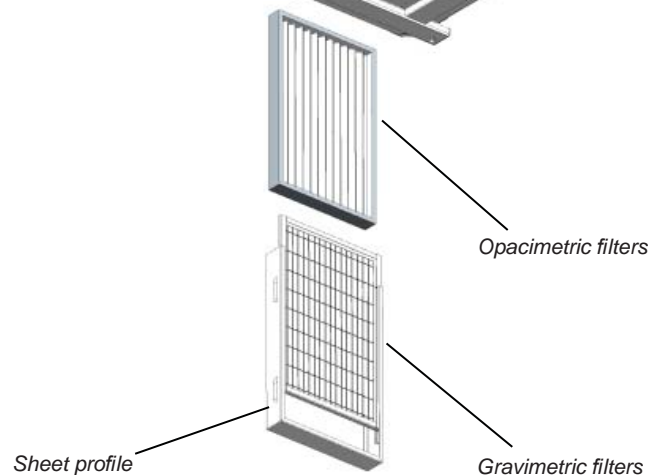
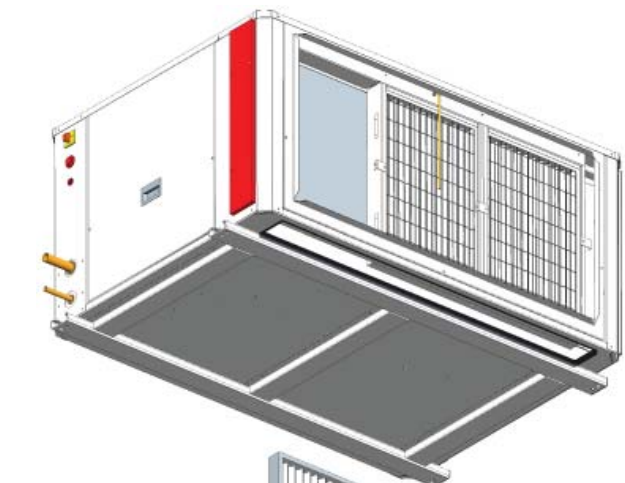
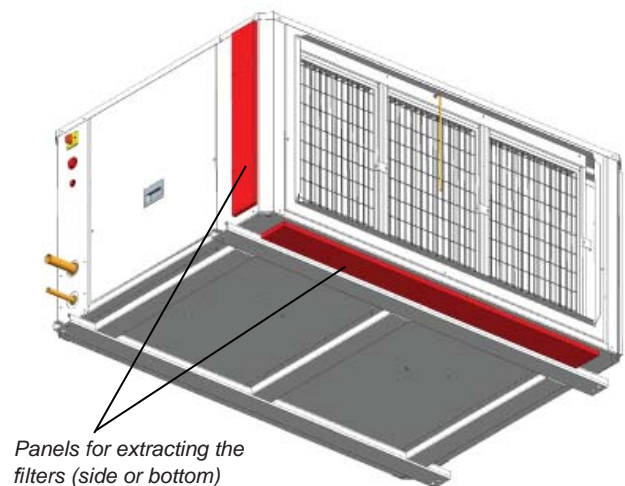

### Models 420 to 600 of CK units

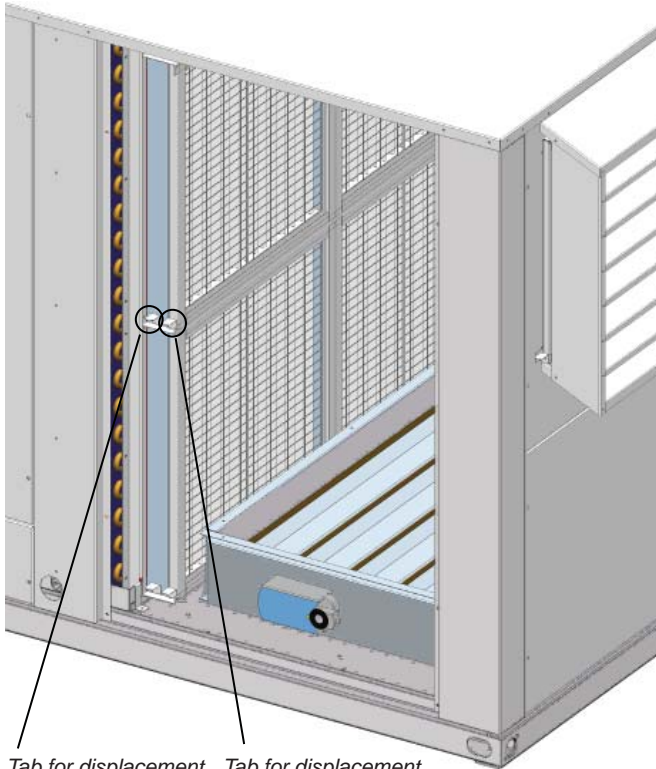

Tab for displacement of opacimetric filters    Tab for displacement of gravimetric filters

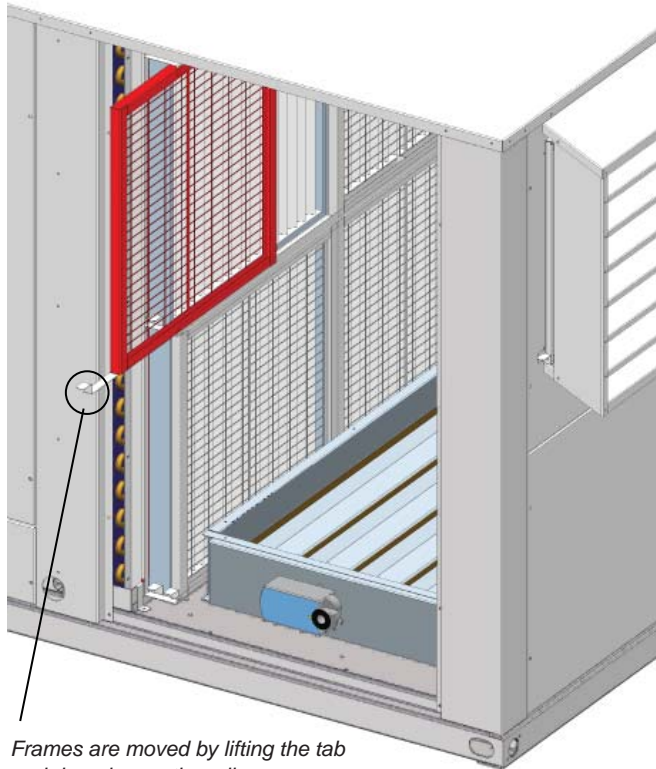

Frames are moved by lifting the tab and dragging on the rail

**Note:** assemblies with centrifugal return fan can also have filtration at the air return (please, consult).

The available options are:

- Gravimetric filter G4.
- Opacimetric creased filters F6 + gravimetric G4.

### CP units

In the indoor CP unit, the gravimetric filters can also be replaced by double stage opacimetric filters: F6 + F7, F6 + F8 or F7 + F9.

It is necessary to lift the tab and drag it down the rail in order to extract the frames.

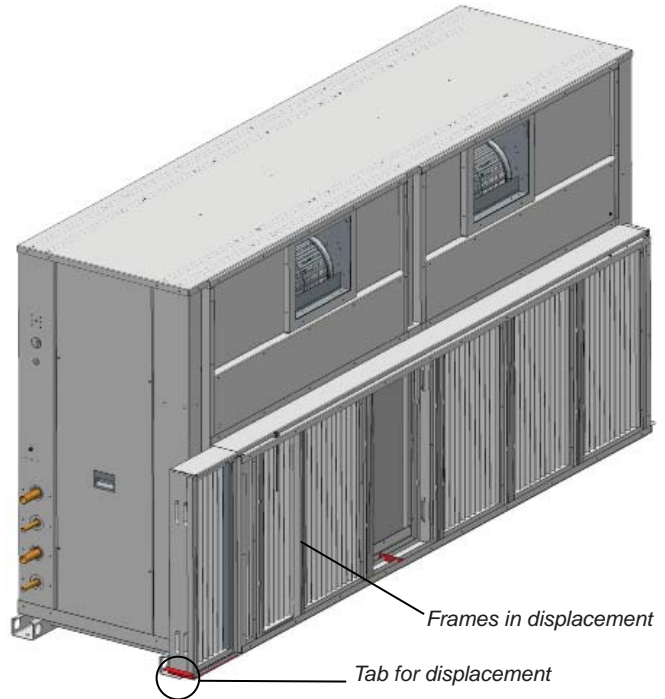

### CP units with MFVA module

When the unit is coupled to a MFVA module, the frame with filters is located inside this module.

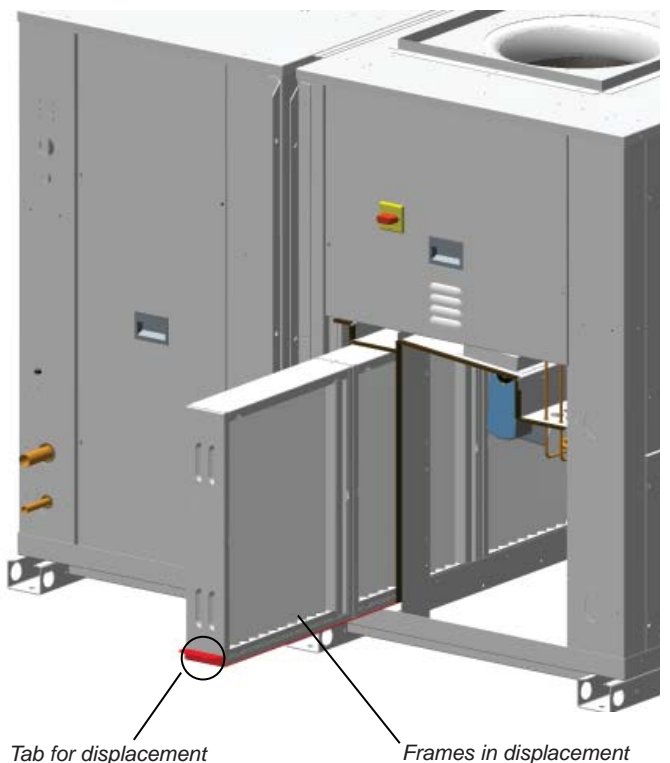

### 14. COMMISSIONING

#### Checks prior to commissioning

- It is advisable to make a complete sketch of the installation including the location of the unit and all the components used. This will be very helpful for maintenance and repairs to the installation.
- The following must be verified:
  - That the electrical power supply remains constant and that it corresponds to that featured on the unit data plate.
  - That the electric installation has been carried out according to the electric wiring diagram provided with the unit (consult the chapter on "Checking before commissioning").
  - The correct connection of the sensors supplied with the unit.
  - That they are no cables close to heat sources.
- Once the above verifications have been carried out, the control circuit is supplied with voltage by the automatic control switch. It is necessary to leave the compressor crankcase heater with voltage for 24 hours before starting the compressor.

- When commissioning the compressor(s), check the subcooling and overheating and thus verify if the refrigerant load is appropriate to the operating conditions.

**R 410A**

- If the refrigerant load has not been completed and is lower than that required, the suction pressure will be rather lower than normal, and overheating when suctioning from the compressors will be high. This can cause an interruption in operation due to activation of the refrigerant load safety device.
- If the refrigerant load is insufficient the liquid sight glass will not be clean, gas bubbles will appear as foam. To adjust the refrigerant load, a schrader valve is built into the unit on the liquid line.
- The liquid sight glass can be accessed via the electric panel (in models SK - 90 to 320) or through the cooling circuit since it is located in the actual pipe (in models SK - 360 to 600).

**WICHTIG: WIEDERBEHEIZUNG DER OLWANNE**

BEIDER ERSTEN INBETRIEBSETRUNZ ORDER NACH EINER LANGEN STROMUNTER-BRECHUNG BRINGEN SIE DIE MASCHINE UNTER SPANNUNG 24 STRUNDERLANG BEVOR SIE DEN(DIE) KOMPRESSOR(EN) EINSCHALTEN KOENNEN.

**IMPORTANT: CRANKCASE HEATING**

FOR THE FIRSTSTART OR AFTER A LONG TIME OUT OF VOLTAGE PUT THE MACHINE ON LIVE 24 HOURS BEFORE TO ALLOW THE COMPRESSOR(S) STARTING

**IMPORTANT: SURCHAUFFE CARTER D'HUILE**

AU PREMIER DÉMARRAGE OU APRÈS UNE ABSCENCE DE COURANT PROLONGÉE, METTRE LA MACHINE SOUS TENSION 24 HEURES AVANT D'AUTORISER LE DÉMARRAGE DU(DES) COMPRESSEUR(S).

**IMPORTANTE: RISCALDARE IL CARTER DELL'OLIO**

AL PRIMO AVVIAMENTO U DOPO UNA INTERRUZIONE PROLUNGATA DELLA ALIMENTAZIONE ELETTRICA, LASCIARE LA MACCHINA SOTTO TENSIONE PER 24 ORE PRIMA DI AUTORIZZARE L'AVVIAMENTO DEL(DEI) COMPRESSORE(I).

**IMPORTANTE: RECALENTAMIENTO DE ACEITE DEL CÁRTER**

ANTES DEL PRIMER ARRANQUE O DESPUÉS DE UNA AUSENCIA DE CORRIENTE POR UN LARGO PERIODO DE TIEMPO, CONVIENE QUE LA UNIDAD ESTÉ CONECTADA UN MÍNIMO DE 24 HORAS.

V220084

- All the SK models are equipped with scroll type compressors and have a phase control relay. Verify that they turn in the correct direction and, if not, reverse the power wires.

**SCROLL COMPRESSOR.  
CHECK SENSE OF ROTATION  
COMPRESSEUR SCROLL.  
VÉRIFIER LE SENS DE ROTATION  
COMPRESOR SCROLL.  
COMPROBAR SENTIDO DE GIRO**

V220040

Models SK 90 to 320 (coil in U)

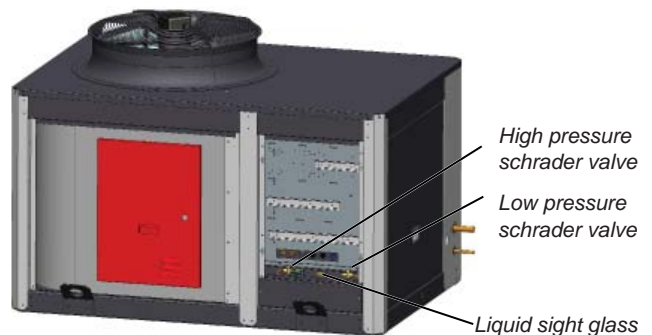

Models SK 360 to 600 (coils in V)

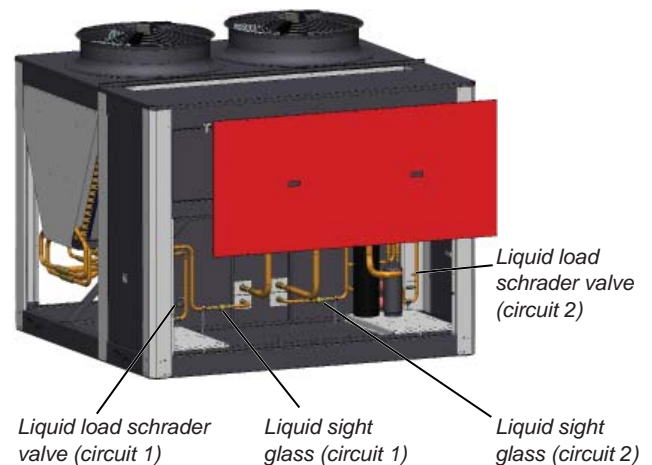

- Verify the absence of any leaks of the refrigerant. In the event of a leak completely empty the unit using a specific recovery unit for R-410A. Refill by following the recommendations featured in the chapter "Checking before commissioning".
- Check the unit operation and verify the safety devices.



# Split cooling units and heat pumps

## Possible problems at commissioning

All indications given in this brochure must be respected and complied with to guarantee a correct operation of the units.

Next, several possible operation problems are stated which could happen if the conditions of the commissioning are not appropriate.

- Air flow lack: very high differences between inlet and outlet temperatures, originated by a high pressure drop in the ducts, or by other causes that impede the correct circulation.
- Air recirculation in the unit, originated by some obstacle in the air aspiration or outlet.
- Noise problems because of excessive air flow in the grille.
- Water overflowing to the pan problems, originated by an excessive flow, an incorrect siphon installation or because a defective unit level.
- Refrigerant circuit humidity problem, because of an incorrect vacuum realization.

## Operational checks

Check the unit operation by verifying the electronic control and the safety devices.

It is also recommendable to create a report, taking note of the date, which includes the following information:

- the nominal power,
- current absorbed by the compressors, fans, and other electric components,
- the significant temperatures of the cooling circuit (see attached table),
- and other aspects that are considered interesting, such as, for example, alarms detected by the electronic control of the unit.

The recording of these parameters whilst the unit is running allows controlling the installation performance and it is the best possible way to avoid breakdowns since the analysis of these data makes early detection of anomalies possible or the provision of the necessary means available to ensure that they do not take place.

Cooling MODE		
Compressor	Suction pressure	bar
	Suction temperature (1)	°C
	Condensation pressure	bar
	Condensation temperature (2)	°C
Air condenser	Gas inlet temperature	°C
	Liquid outlet temperature (3)	°C
	Air inlet temperature	°C
	Outdoor temperature	°C
	Air outlet temperature	°C
Air evaporator	Air inlet temperature	°C
	Air outlet temperature	°C
	Liquid inlet temperature	°C
	Evaporation outlet temperature (4)	°C
Subcooling (2) - (3)		°C
Overheating (4) - (1)		°C

Heating MODE		
Compressor	Suction pressure	bar
	Suction temperature (1)	°C
	Condensation pressure	bar
	Condensation temperature (2)	°C
Air evaporator	Liquid inlet temperature	°C
	Gas outlet temperature (4)	°C
	Air inlet temperature	°C
	Outdoor temperature	°C
	Air outlet temperature	°C
Air condenser	Air inlet temperature	°C
	Air outlet temperature	°C
	Gas inlet temperature	°C
	Liquid outlet temperature (3)	°C
Subcooling (2) - (3)		°C
Overheating (4) - (1)		°C

### 15. MAINTENANCE

The minimal maintenance operations and their periodicity will be made according to the national regulations.

Any intervention on the electric cooling components must be made by a qualified and authorized technician.

Technicians who intervene with the unit must use the necessary safety equipment (gloves, goggles, insulating clothing, safety shoes, etc.).

Furthermore, if working around sources of significant noise, we recommend the use of noise-dampening headgear.



**Caution: Before intervening in the unit, cut off main power.**

#### General recommendations:

- Do not lean on the unit. A platform must be used to work on a level.
- Do not lean on the copper refrigerant tubes.
- Keep the unit clean.
- Keep the space surrounding the unit clean and cleared in order to avoid accidents and ensure the proper ventilation of the coil.
- Perform a visual (remains of water or oil below or around the unit) and auditory inspection of the entire installation.
- In general, a corrosion control must be performed on the metallic parts of the unit (frame, bodywork, exchangers, electric panel, etc.).
- Check that the insulation foam is not unstuck or torn.
- All the electric connection states must be checked as well, as well as the air tightness of the different circuits.

Next, some recommendations are stated to perform the cleaning of the unit's components:

#### Condensate drain pan

- Check that the condensate pan is clean. There should be no stagnant water.
- Check that the drain is not clogged.
- Cleaning of the pan can be done with water and non-abrasive detergent.

Note: in the section "Condensate drain connection" are images with the position of the drain for all units.

#### Air coil

- Check that the coil is free from dust and grease.
- Cleaning the accumulated dust on the coil can be performed with a vacuum cleaner perpendicular to the fins or with a low-pressure water cleaner. Grease can be removed with water with degreaser. Do not put stress on the fins as they could deform.

Note: models SK - 90 to 320 with coil in U may incorporate a protection grille for the coil (optional). This grille is fixed by modules in the holes made for this goal in the unit's support. Remove the grille to clean the coil.

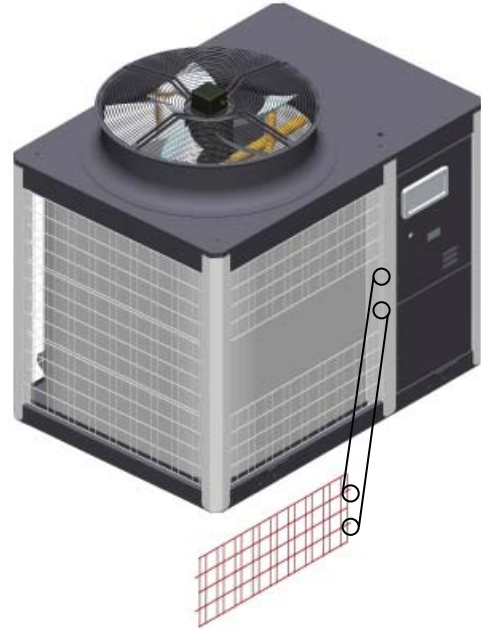

Use safety gloves for this task. Take care with the sharp parts of the coil.

#### Air filters

- Clean regularly. Depending on the installation conditions, the filter aspect must be examined to define the cleaning periodicity.
- Gravimetric filters. Cleaning the filtering mesh can be done with a household vacuum cleaner, or else by submerging it in water.
- Creased opacimetric filters. It is necessary to replace them. Foresee replacement.

#### Models CK - 90 to 360

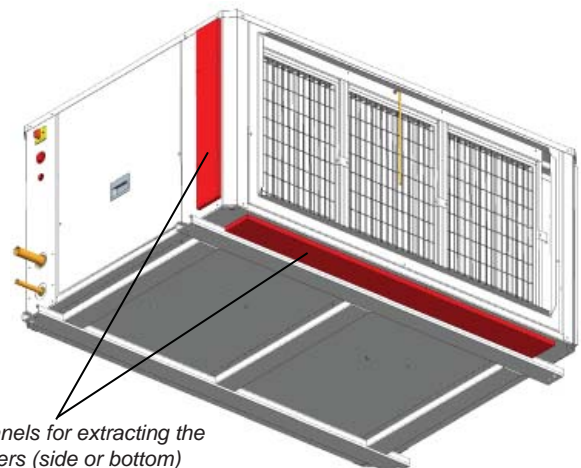

Panels for extracting the filters (side or bottom)

## Models CK- 420 to 600

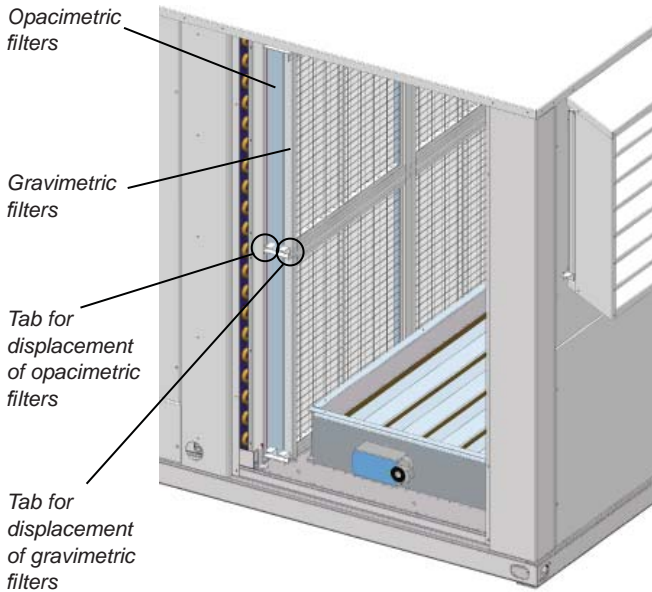

## Models CP

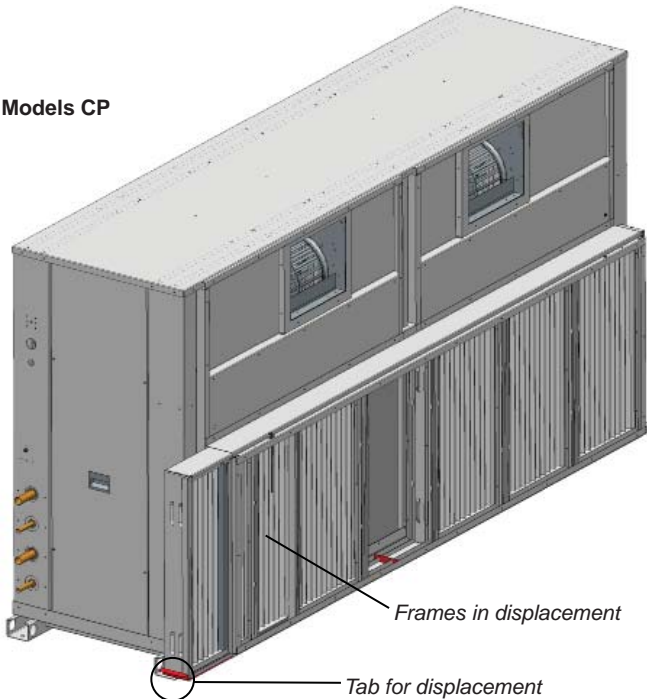

## Centrifugal fan

- Verify that the turbine and the motor remain clean.
- Foresee having a spare belt set for the fans.
- The motors and the fans have bearings that have been lubricated and sealed and, thus, do not need further lubrication (except in the case of fans with a reinforced shaft).

## Servomotor (optional)

In indoor units CK and CP with motorized mixing boxes, it is advisable to check the condition of the servomotors.

**Note:** The available assemblies can be consulted in chapter 4 "Available assemblies".

## Compressor

In the case of compressor replacement:

- Disconnect the unit from power supply.
- Completely empty the load of refrigerant using a specific recovery unit for R-410A
- Disconnect electrically the compressor.
- Carefully unscrew the suction and discharge piping.
- The compressor is fixed onto the platform with 4 screws Ø 8 mm. Unscrew the fixings.
- Place the new compressor and check that it has a sufficient oil charge.  
Warning: when tightening the compressor screws, please consult the maximum torque that can be applied.
- If a torque wrench is not available, tighten them until noticing resistance, then tighten the screws by turning them 3/4 of a revolution.
- Screw the suction and discharge piping.
- Connect the compressor in accordance with the circuit diagram.
- Make vacuum and next, reload the gas into the unit according to load data provided in the technical characteristics table and in the unit's data plate.

## Filter drier

- The filter function is to keep the cooling circuit clean and without humidity, neutralising the acids that can be found in the cooling circuit.
- Verify dirt measuring the difference in temperature at the piping level, at the inlet and at the outlet of the filter.
- If necessary, replace.



### Liquid sight glass

- This sight glass, located on the liquid line, after the dehydrating filter, enables controlling the refrigerant load and the presence of moisture in the circuit. The presence of bubbles in the indicator means that the refrigerant fluid load is insufficient or that there are non-condensable products in the cooling circuit. The presence of moisture is characterised by the change in colour of the control paper located on the sight glass.
- In the SK units the liquid sight glass is accessed via the access panel to the electric panel (models 90 to 320) or via the cooling circuit access (models 360 to 600).

### Warning:

If the unit stops, certain indicators may appear in yellow; the change in colour is due to the sensitivity, which depends on the temperature of the fluid.

These will change to green after a few hours of the unit operating.

If the indicators remain yellow, that will indicate the presence of excessive humidity in the circuit. This will require the presence of a specialist.

### Oil

Oils used for cooling machines do not post any threat to one's health if used while following the usage guidelines:

- Avoid any unnecessary manipulation of the elements covered in oil. Use protection creams.
- Oils are flammable and must be stored and handled with precaution. "Disposable" rags or towels used for cleaning must be kept away from open flames and must be discarded by using the appropriate procedure.
- Jugs must be kept closed. Avoid using oil from an already-open jug kept in poor conditions.

Both the oil type as well as the volume needed for each model are stated in the "Technical characteristics" tables given in this manual.

- Check the oil level and aspect. In case of a colour change, check the oil quality using a contamination test.
- In the case of the presence of acid, water or metallic particles, replace the affected circuit oil, as well as the filter drier.
- In the event of an oil charge change, only new oil will be used, which will be identical to the original oil and taken from a jug tightly closed until the moment of the charge.

### Oil separator (optional)

When the maximum equivalent length of the cooling line is greater than 50 metres, an oil separator must be fitted.

- During the first few days of operation check the oil level in the compressor sight glass. If there is not enough, oil can be added (via the compressor schrader valve or the unit low pressure).

### Refrigerant

Only qualified personnel must perform a periodic tightness control, in accordance with the regulation (CE) N° 517/2014.

- The frequency of checks is no longer related to the load of refrigerant but to its global warming potential:

$$\text{Load kg} \times \text{GWP} = \text{t CO}_2\text{e}$$

Carbon dioxide equivalency (t CO<sub>2</sub>e) is a quantity that describes, for a given mixture and amount of greenhouse gas, the amount in tonnes of CO<sub>2</sub> that would have the same global warming potential (GWP). Please, consult data of carbon dioxide equivalency (t CO<sub>2</sub>e) provided in the technical characteristics tables of this manual.

- Operators shall ensure that the unit is checked for leaks ad minima according to the following frequency:
  - t CO<sub>2</sub>e < 5 ..... not subjected
  - t CO<sub>2</sub>e 5 to 50 ..... every year
  - t CO<sub>2</sub>e 50 to 500 ... every 6 months
  - t CO<sub>2</sub>e > 500 ..... every 3 months
- Where a leakage detection system has been installed the frequency of checks is halved.

Note: Never forget that the cooling systems contain liquids and vapours under pressure. The service pressure of R-410A is approximately 1.5 higher than that of R-407C.

- All necessary precautions must be taken during the partial opening of the cooling circuit. This opening entails the discharge of a certain amount of refrigerant to the atmosphere. It is essential to limit this quantity of lost refrigerant to a minimum by pumping and isolating the charge in some other part of the circuit.
- The refrigerant fluid at low temperature can cause inflammatory injuries similar to burns when contacting the skin or eyes. Always use safety goggles, gloves, etc. when opening ducts that may contain liquids.
- The refrigerant in excess must be stored in appropriate containers and the amount of refrigerant stored at the technical rooms must be limited.
- Refrigerant barrels and deposits must be handled with precaution and visible warning signs must be placed to attract attention over the risks of intoxication, fire and explosion linked to the refrigerant.
- At the end of its useful life, the refrigerant must be retrieved and recycled as per the current regulations.

### Refrigerant leak detector (optional)

Maintenance:

- Annual testing: it is necessary to carry out testing every year to comply with the EN378 and F-GAS regulations.
- Every 3 years: a taring test is recommended.
- Every 5/6 years: it is recommended that the gas detection element be replaced and calibration performed.

**Note:** Check the documentation attached to the leak detector for taring and calibration testing.





## 16. CONTROL AND ANALYSIS OF BREAKDOWNS

Symptom	Cause	Solution
Evaporation pressure very high in relation with the air inlet	<ul style="list-style-type: none"> <li>a) Charge excess</li> <li>b) High air temperature</li> <li>c) Compressor suction not air tight</li> <li>d) Cycle reversing valve in middle position</li> </ul>	<ul style="list-style-type: none"> <li>a) Collect refrigerant</li> <li>b) Verify overheating</li> <li>c) Verify compressor state and replace</li> <li>d) Check that the valve is not clogged. Replace if necessary</li> </ul>
Very low condensation pressure	<ul style="list-style-type: none"> <li>a) Gas lack</li> <li>b) Compressor suction not air tight</li> <li>c) Cycle reversing valve in middle position</li> <li>d) Liquid circuit plugging</li> </ul>	<ul style="list-style-type: none"> <li>a) Search for leaks, complete charge</li> <li>b) Verify compressor state and replace</li> <li>c) Check that the valve is not clogged. Replace if necessary</li> <li>d) Verify the dehydrating filter and expansion valve</li> </ul>
Condensation pressure very high in relation to the air outlet, high pressostat cutoff	<ul style="list-style-type: none"> <li>a) Insufficient air flow</li> <li>b) Air inlet temperature very high</li> <li>c) Dirty condenser (does not exchange)</li> <li>d) Much refrigerant load (flooded condenser)</li> <li>e) The condenser fan is broken down</li> <li>f) Air in the cooling circuit</li> </ul>	<ul style="list-style-type: none"> <li>a) Verify the air circuits (flow, filter cleanliness...)</li> <li>b) Verify the control thermostat readjustment</li> <li>c) Clean it</li> <li>d) Collect refrigerant</li> <li>e) Repair</li> <li>f) Make vacuum and load</li> </ul>
Evaporation pressure too low (low pressostat cut-off)	<ul style="list-style-type: none"> <li>a) Low flow in evaporator. Air recirculation</li> <li>b) Frozen evaporator</li> <li>c) Liquid line as different temperatures at filter inlet and outlet</li> <li>d) Gas lack</li> <li>e) Very low condensation pressure</li> <li>f) Evaporator fan broken down</li> </ul>	<ul style="list-style-type: none"> <li>a) Verify the air circuits (flow, filter cleanliness...)</li> <li>b) Verify defrost</li> <li>c) Replace filter</li> <li>d) Search for leaks, complete charge</li> <li>e) Temperature of air or water in condenser very low (air or water flow very high), adjust flow</li> <li>f) Repair</li> </ul>
Compressor does not start, does not make noise (humming)	<ul style="list-style-type: none"> <li>a) No power</li> <li>b) The contacts of a control element are open</li> <li>c) Timing of anti cycle short does not allow the starting</li> <li>d) Open contact</li> <li>e) Contactor coil burnt</li> <li>f) Indoor klixon open</li> </ul>	<ul style="list-style-type: none"> <li>a) Check differential, fuses</li> <li>b) Verify the safety chain of the electronic control</li> <li>c) Verify electronic control</li> <li>d) Replace</li> <li>e) Replace</li> <li>f) Wait for reactivation, verify current absorbed</li> </ul>
Compressor does not start, motor sounds intermittently	<ul style="list-style-type: none"> <li>a) Electrical power supply very low</li> <li>b) Power cable disconnected</li> </ul>	<ul style="list-style-type: none"> <li>a) Control line voltage and locate voltage drop</li> <li>b) Verify connections</li> </ul>
Repeated compressor starts and stops	<ul style="list-style-type: none"> <li>a) Because of high pressure</li> <li>b) Control differential too short (short cycle)</li> <li>c) Insufficient gas, cut-off because of low pressure</li> <li>d) Dirty or frosted evaporator</li> <li>e) The evaporator fan does not work, cuts off the low pressostat</li> <li>f) Expansion valve damaged or clogged by impurities (cuts off low pressostat)</li> <li>g) Dehydrating filter clogged (cuts off low safety)</li> </ul>	<ul style="list-style-type: none"> <li>a) Verify charge</li> <li>b) Increase differential</li> <li>c) Search for leak, reload unit</li> <li>d) Clean, verify evaporator air circuit</li> <li>e) Replace or repair</li> <li>f) Replace, as well as filter</li> <li>g) Replace</li> </ul>
The compressor makes a noise	<ul style="list-style-type: none"> <li>a) Loose attachment</li> <li>b) Oil lack</li> <li>c) Compressor noise</li> </ul>	<ul style="list-style-type: none"> <li>a) Fix</li> <li>b) Add oil to recommended level</li> <li>c) Replace</li> </ul>
Noisy operation	<ul style="list-style-type: none"> <li>a) Unit installed without antivibration protection</li> </ul>	<ul style="list-style-type: none"> <li>a) Place base over shock absorbers</li> </ul>
Cycle reversing is not carried out: - No defrosting - Does not change winter - summer cycles	<ul style="list-style-type: none"> <li>a) Electrical fault</li> <li>b) Inversion valve coil defective</li> <li>c) Defrost method not working</li> <li>d) Cycle reversing valve in middle position</li> <li>e) Control fault</li> </ul>	<ul style="list-style-type: none"> <li>a) Locate and repair</li> <li>b) Replace</li> <li>c) Verify parameters</li> <li>d) Tap with running compressor. Replace if necessary</li> <li>e) Locate and repair</li> </ul>
Alarm or reading error in the humidity probe (with CIATrhc enthalpic electronic control)	<ul style="list-style-type: none"> <li>a) Dirt in the humidity sensor</li> </ul>	<ul style="list-style-type: none"> <li>a) Disassembly the probe capsule</li> <li>b) Proceed to clean the sensor with some soft cotton element and non-abrasive fluid, without pressing it</li> <li>c) Reassemble the casing, checking that the cable is in contact externally with the metallic mesh</li> </ul>





