



“Energy excellence

- Compact and silent*
- Scroll compressors*
- High efficiency brazed-plate heat exchangers*
- All-aluminium micro-channel condenser*
- Self-adjusting electronic control*

Cooling capacity: 168 to 523 kW



Cooling only



Hydraulic module



Heat recovery



USE

The new generation of **AQUACIAT^{POWER}** high efficiency air-to-water water chillers offers an optimal solution for all cooling applications used for the Office, Healthcare, Industry, Administration, Retail and Collective housing sectors.

These units are designed for outdoor installation and require no special protection against adverse weather conditions.

The **AQUACIAT^{POWER}** is optimised to use ozone-friendly HFC R410A refrigerant.

This range guarantees compliance with the most demanding requirements for increased seasonal energy efficiency (ESEER) and CO₂ reduction to comply with the various applicable European directives and regulations.

RANGE

AQUACIAT^{POWER} LD ST series

Standard cooling only version.

The product is optimised to meet the most demanding technical and economic requirements.

AQUACIAT^{POWER} LD HE series

Cooling only version High seasonal energy efficiency.

The product is optimised for partial-load applications for which an optimum value of ESEER is required. In this case, the machine is equipped with EC-type variable-speed fans as standard, allowing for optimisation of the partial load efficiency throughout the year.

DESCRIPTION

The AQUACIAT^{POWER} units are packaged machines supplied as standard with the following components:

- Hermetic SCROLL compressors
- Chilled-water evaporator with brazed plates
- Air-cooled exchanger, all-aluminium micro-channel coil with axial fan motor assembly
- Electrical power and remote control cabinet:
 - 400V-3ph-50Hz (+/-10%) general power supply + earth
 - transformer fitted as standard on the machine for supplying the remote control circuit with 24 V
- Connect Touch electronic control module
- Casing for outdoor installation

The entire AQUACIAT^{POWER} range complies with the following EC directives and standards:

- Machinery directive 2006/42/EC.
- Electromagnetic compatibility directive 2004/108/EC.
- Electromagnetic compatibility immunity and emissions EN 61800-3 'C3'
- Low voltage directive 2006/95/EC.
- RoHS 2011/65/EU
- Pressure equipment directive (PED) 97/23/EC
- Machinery directive EN 60-204 - 1
- Refrigerating systems and heat pumps EN 378-2

DESCRIPTION

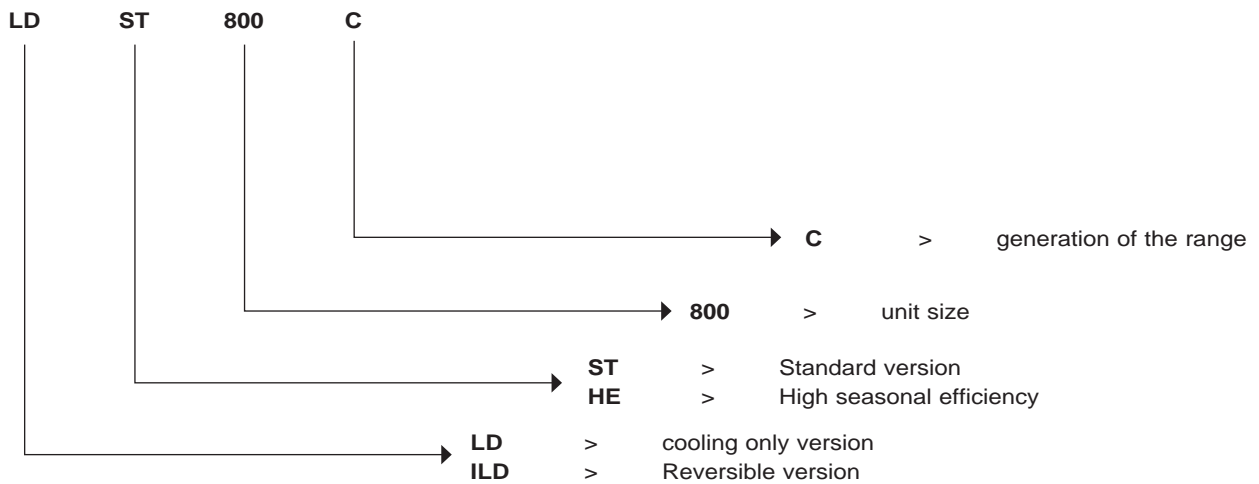

CONFIGURATION

ST	Standard	HE	High Seasonal Efficiency
ST LN option	Standard Low Noise	HE LN option	High Seasonal Efficiency Low Noise
ST XLN option	Standard Xtra Low Noise	HE XLN option	High Seasonal Efficiency Xtra Low Noise

DESCRIPTION OF THE MAIN COMPONENTS

■ Compressors

- Hermetic SCROLL type
- Electronic motor overheating protection
- Crankcase heater
- Mounted on anti-vibration mounts

■ Evaporator

- Exchanger with asymmetrical brazed plates
- Plate patterns optimised for high efficiency
- 19 mm armafex thermal insulation

■ Condenser

- Air-cooled exchanger, all-aluminium micro-channel coil
- Axial fans with composite blades offering an optimised profile, fixed speed (ST version) or variable speed (HE version)
- Motors – IP 54, class F

■ Refrigerating accessories

- Dehumidifier filters with rechargeable cartridges
- Hygroscopic sight glasses
- Electronic expansion valves
- Service valves on the liquid line

■ Control and safety instruments

- Low and high pressure sensors
- Safety valves on refrigerating circuit
- Water temperature control sensors
- Evaporator antifreeze protection sensor
- Factory-fitted evaporator water flow rate controller

■ Electrical cabinet

- Electrical cabinet with IP 54 protection rating (IP44 for the entire unit)
- A connection point without neutral
- Front-mounted main safety switch with handle
- Control circuit transformer
- 24 V control circuit
- Fan and compressor motor circuit breaker
- Fan and compressor motor contactors
- Connect Touch microprocessor-controlled electronic control module
- Wire numbering
- Marking of the main electrical components

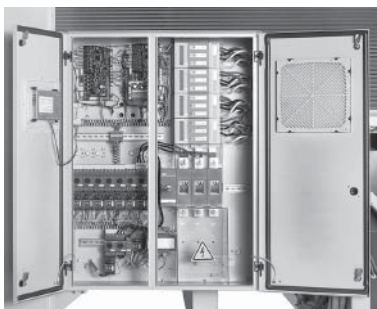

■ Frame

Frame made from RAL 7035 light grey & RAL 7024 graphite grey painted panels

■ Connect Touch control module

- User interface with 5 inch touchscreen
- Intuitive, user-friendly navigation using icons
- Clear text display of information available in eight languages (F-GB-D-NL-E-I-P + Chinese)



The electronic control module performs the following main functions:

- Regulation of the chilled water temperature (at the return or at the outlet)
- Regulation of the water temperature based on the outdoor temperature (water law)
- Regulation for low temperature energy storage
- Second setpoint management
- Complete management of compressors with start-up sequence, timer and runtime balancing
- Self-adjusting and proactive functions with adjustment of settings on drift control
- In-series staged power control system on the compressors according to the thermal requirements
- Management of compressor short-cycle protection
- Frost protection (exchanger heater option)
- Phase reversal protection
- Management of occupied/unoccupied modes (according to the time schedule)
- Compressor and pump operating time balancing
- Management of the machine operation limit according to outdoor temperature
- Noise level reduction device (night mode according to the user programme) with limitation of compressor capacity and fan speed
- Diagnosis of fault and operating statuses
- Management of a fault memory allowing a log of the last 50 incidents to be accessed, with operating readings taken when the fault occurs
- Blackbox memory
- Master/slave management of the two machines in parallel with operating time balancing and automatic changeover if a fault occurs on one machine
- Weekly and hourly time schedule for the machine, including 16 periods of absence
- Pump standby based on demand (energy saving)
- Calculation of the water flow rate and operating pressure (hydraulic module version)
- Electronic adjustment of the water pump speed and water flow rate (variable speed pump option)
- Display of all machine parameters (3 access levels, User/Maintenance/Factory, password-protected): temperature, setpoints, pressures, water flow rate (hydraulic version), runtime.
- Display of trend curves for the main values
- Storage of maintenance manual, wiring diagram and spare parts list.

■ Remote control

Connect Touch is equipped as standard with an RS485 port and an ETHERNET (IP) connection, offering a range of options for remote management, monitoring and diagnostics.

Using the integrated Webserver, a simple internet connection uses the unit's IP address to access the Connect Touch interface on the PC, facilitating everyday management tasks and maintenance operations.

A range of communication protocols are available: MODBUS/JBUS RTU (RS485) or TC/IP as standard, LONWORKS – BACNET IP as an option, enabling most CMS/BMS to be integrated

Several contacts are available as standard, enabling the machine to be controlled remotely by wired link:

- Automatic operation control: when this contact is open, the machine stops
- Setpoint 1/setpoint 2 selector: when this contact is closed, a second cooling setpoint is activated (energy storage or unoccupied mode, for example)
- Power limitation: closing the contact concerned allows the power or refrigerating consumption of the machine to be limited by stopping one or more compressors (this limit can be set with a parameter)
- Fault reporting: this contact indicates the presence of a major fault which has caused one or both refrigerating circuits to stop
- Operational status reporting indicates that the unit is in production mode.
- Activation control for partial energy recovery using the desuperheater.
- Switch control for the customer pump, external to the machine (on/off).

Contacts available as an option:

- Setpoint adjustable via 4-20 mA signal: this input is used to adjust the setpoint in COOLING mode
- Power limitation adjustable by 4-20 mA signal
- Second power limitation level
- Power indication: analogue output (0-10 V) providing an indication of the unit's load rate.
- User fault reporting enables integration of a fault in the water loop
- General fault reporting: this contact indicates that the unit has stopped completely
- Alert reporting: this contact indicates the presence of a minor fault which has not caused the circuit affected to stop.
- End of storage signal: enables return to the second setpoint at the end of the storage cycle
- Schedule override: closing this contact cancels the time schedule.
- Desuperheater activation control
- Desuperheater pump On/Off control

■ Maintenance

Connect Touch has two maintenance reminder functions as standard, making users aware of the need to regularly perform maintenance operations and to guarantee the service life and performance of the unit. These two functions can be activated independently.

A reminder message appears on the unit's HMI screen, and stays there until it is acknowledged by the maintenance operator. The information and alert relating to these functions are available on the communication bus to be used on the CMS/BMS.

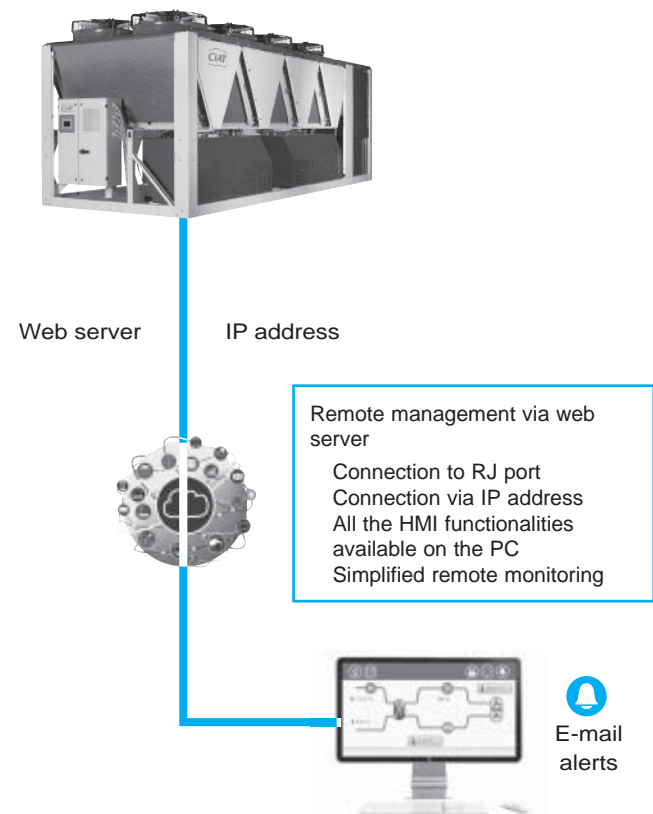

- The scheduled maintenance reminder: when activated, this function enables the period between two maintenance inspections to be set. This period may be set by the operator in either days, months or operating hours, depending on the application.
- The compulsory F-GAS sealing test maintenance reminder: when activated, this function, which is the default factory setting, enables the period between two sealing tests to be selected, according to the unit's refrigerant charge, in compliance with the F-GAS regulations.

■ CIATM2M, the CIAT supervision solution

CIATM2M is a remote supervision solution dedicated to monitoring and controlling several CIAT machines in real time.

Advantages

- Access to the operating trend curves for analysis
- Improved energy performance
- Improved availability rate for the machines

Functions

CIATM2M will send data in real time to the supervision website, www.ciatm2m.com.

The machine operating data can be accessed from any PC, smartphone or tablet.

Any event can be configured to trigger a mail alert.

Parameters monitored:

- Overview
- Control panel for the controllers
- Events
- Temperature curves

Monthly and annual reports are available to analyse:

- The performance and operation of the machine
Example: operating curves and time, number of compressor start-ups, events, preventive maintenance actions to be performed, etc.
- The electricity consumed (if the energy meter option is present)

Incidents such as a deviation in the measurements on a temperature sensor, incorrectly set control parameters, or even incorrect settings between one compressor stage and the other are immediately detected, and the corrective actions put in place.

Equipment

This kit can be used on both machines which are already in use (existing inventory), and on new machines which do not have sufficient space in their electrical cabinets.

- 1 transportable cabinet
- 1 wall-mounted antenna

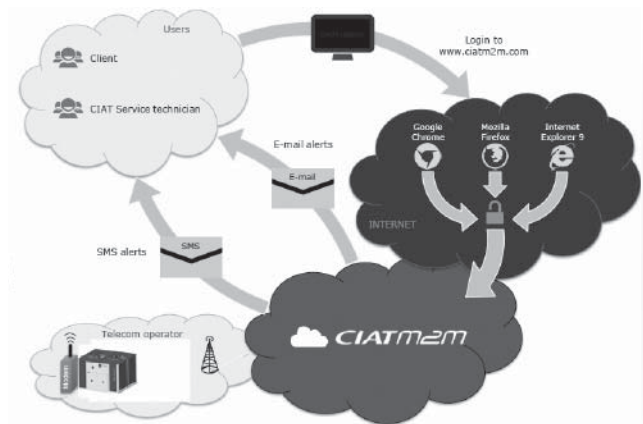

CIATM2M kit contents

- 1 GPRS/3G modem
- 1 SIM card
- 1 x 24 V DC power supply
- 1 power protection device
- 1 GSM antenna
- Rail mounting
- Enclosed casing to protect the equipment during transport
- Packing box for cable routing (bus, power supply, Ethernet)

Compatibility

Up to three machines per CIATM2M kit

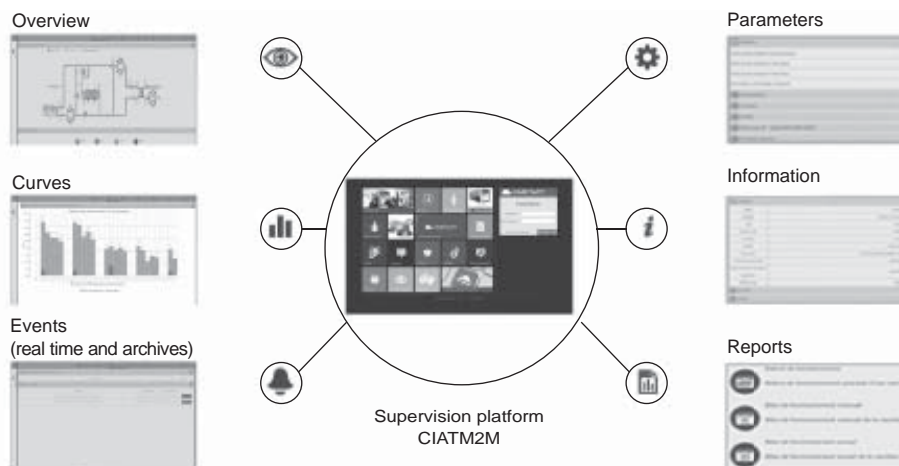

AVAILABLE OPTIONS

Options	Description	Advantages	LD
Low Noise	Aesthetic and sound absorbing compressor enclosure	Noise level reduction by 1 to 2 dB(A)	ST/HE versions
Xtra Low Noise	Acoustic compressor enclosure and low-speed fans	Noise level reduction by 6 to 7 dB(A)	ST/HE versions
IP54 control box	Increased leak tightness of the unit	Protects the inside of the electrical box from dust, water and sand. In general, this option is recommended for installations in polluted environments	ST/HE versions
Protection grilles	Metal grilles on the 4 unit sides.	Improves protection against intrusion inside the unit, and protects the coil and piping against impacts.	ST/HE versions
Soft Starter	Electronic starter on each compressor	Reduced start-up current	ST/HE versions
Winter operation (down to -20°C)	Fan speed control	Stable unit operation when the air temperature is between 0°C and -20°C.	ST version
Water exchanger frost protection	Electric heater on the water exchanger and the water piping	Water exchanger module frost protection between 0°C and -20°C outside air temperature	ST/HE versions
Water exchanger and hydraulic mod. frost protection	Electric heater on the water exchanger hydraulic module and optional expansion tank	Water exchanger and hydraulic module frost protection for outdoor operating temperatures down to -20°C	ST/HE versions
Water exchanger and hydraulic module frost protection	Electric heaters on the water exchanger, water pipes, hydraulic module, optional expansion vessel and buffer tank module	Water exchanger and hydraulic module frost protection for outdoor operating temperatures down to -20°C	ST/HE versions
Partial heat recovery	Unit equipped with one desuperheater on each refrigerant circuit	Production of free high-temperature hot-water simultaneously with chilled water production (or hot water for Heat pump)	ST/HE versions
Master/slave operation	Unit equipped with an additional water outlet temperature sensor, to be installed on site, enabling master/slave operation of two units connected in parallel	Optimised operation of two units connected in parallel with run time equalisation	ST/HE versions
Compressor suction and discharge valves	Shut-off valves on the compressor suction and discharge piping	Simplified maintenance. Possibility to store the refrigerant charge on the water exchanger or air exchanger side during servicing	ST/HE versions
Compressor discharge valves	Shut-off valves on the compressor discharge piping	Simplified maintenance. Possibility to store the refrigerant charge in the condenser side during servicing	ST/HE versions
HP single-pump hydraulic module	Single high-pressure water pump, water filter, electronic water flow control, pressure transducers. For more details, refer to the dedicated section (expansion vessel not included. Option with integrated hydraulic safety components available.)	Quick, easy installation (plug & play)	ST/HE versions
HP dual-pump hydraulic module	Dual high-pressure water pump, water filter, electronic water flow control, pressure sensors. For more details, refer to the dedicated section (expansion vessel not included. Option with integrated hydraulic safety components available.)	Quick, easy installation (plug & play)	ST/HE versions
LP single-pump hydraulic module	Single low-pressure water pump, water filter, electronic water flow control, pressure transducers. For more details, refer to the dedicated section (expansion vessel not included. Option with integrated hydraulic safety components available.)	Quick, easy installation (plug & play)	ST/HE versions
LP dual-pump hydraulic module	Dual low-pressure water pump, water filter, electronic water flow control, pressure transducers. For more details, refer to the dedicated section (expansion vessel not included. Option with integrated hydraulic safety components available.)	Quick, easy installation (plug & play)	ST/HE versions
HP variable-speed single pump hydraulic module	Single high-pressure water pump with variable speed drive (VSD), water filter, electronic water flow control, pressure transducers. Multiple water flow control options. For more details, refer to the dedicated section (expansion vessel not included. Option with integrated hydraulic safety components available.)	Quick, easy installation (plug & play), significant pumping energy consumption savings (more than two-thirds), accurate water flow rate control, improved system reliability	ST/HE versions
HP variable-speed dual pump hydraulic module	Dual high pressure water pump with variable speed drive, water filter, electronic water flow rate control, pressure sensors. Multiple water flow control options. For more details, refer to the dedicated section (expansion vessel not included. Option with integrated hydraulic safety components available.)	Quick, easy installation (plug & play), significant pumping energy consumption savings (more than two-thirds), accurate water flow rate control, improved system reliability	ST/HE versions

AVAILABLE OPTIONS

Options	Description	Advantages	LD
Lon communication gateway	Two-directional communication board complying with Lon Talk protocol	Connects the unit by communication bus to a building management system	ST/HE versions
BACnet/IP	Two-directional high-speed communication using BACnet protocol over Ethernet network (IP)	Easy, high-speed connection by Ethernet line to a building management system. Allows access to multiple unit parameters	ST/HE versions
Energy Management Module	Control board with additional inputs/outputs. See the list of contacts available as an option in the control description.	Extended remote control capabilities (setpoint reset by 0-20 mA input, ice storage end, output limits, boiler on/off command...)	ST/HE versions
Compliance with Russian regulations	EAC certification	Compliance with Russian regulations	ST/HE versions
Power factor correction	Capacitors for automatic regulation of power factor (cos phi) value to 0.95.	Reduction of the apparent electrical power input, compliance with minimum power factor limit set by electricity suppliers	ST/HE versions
Protect2 anti-corrosion protection for micro-channel coils	Coating which uses a conversion process to alter the aluminium surface into a coating which forms an integral part of the coil. Complete immersion in a bath to ensure 100% coverage. No thermal transfer variation, tested to withstand more than 4000 hours of salt spray as per ASTM B117	Protect2 coating which doubles the corrosion resistance offered by micro-channel coils, recommended for use in moderately corrosive environments	ST/HE versions
Protect4 anti-corrosion protection for micro-channel coils	Flexible, durable polyepoxide coating applied using an electroplating process to give micro-channel coils an anti-UV top layer. Minimal variation in the thermal transfer, tested to withstand more than 6000 hours of constant neutral salt spray as per ASTM B117, improved impact resistance as per ASTM D2794	Protect4 coating gives a fourfold increase in the corrosion resistance offered by micro-channel coils, recommended for use in corrosive environments	ST/HE versions
230V electrical plug	230 V AC power supply source provided with plug socket and transformer (180 VA, 0.8 Amps)	Enables connection of a laptop or an electrical device during unit start-up or servicing	ST/HE versions
Expansion vessel	6 bar expansion vessel integrated in the hydraulic module	Easy, quick installation (ready to use), and closed circuit protection of hydraulic systems to counter excessive pressure	ST/HE versions with pump
Connection sleeve to be screwed onto the desuperheater	Desuperheater connections with screwed joints	Easy to install. Used to connect the unit to a threaded connector	ST/HE versions
Buffer tank module	Integrated buffer tank module	Prevents compressor short cycling and provides stability of the water in the loop	ST/HE versions with pump
Anti-vibration mounts	Elastomer anti-vibration mounts to be fitted underneath the unit	Isolates the unit from the building, preventing vibrations and noise from being transmission to the building. Must be used in conjunction with a flexible connection on the water side	ST/HE versions
Flexible couplings for connection to the exchanger	Flexible connections to the water exchanger	Easy to install. Limits the transmission of vibrations to the water network	ST/HE versions
Evaporator water filter	Water filter	Prevents fouling within the water network	ST/HE versions without pump
Setpoint adjustable via 4-20 mA signal	Connections enabling a 4-20 mA signal input	Simplified energy management, enabling the setpoint to be set by a 4-20 mA external signal	ST/HE versions
Free cooling dry cooler management	Control and connections of an Opera or Vextra free cooling dry cooler equipped with the FC control box option	Easy system management, extended control capabilities to a dry cooler used in free cooling mode	ST/HE versions

ACCESSORIES

Accessories	Description	Advantages	LD
M2M 1 supervision units - France	Monitoring solution enabling customers to remotely track and monitor equipment in real time, France only	Real-time expert technical support to increase equipment availability and improve performance.	ST/HE versions
M2M 3 supervision units - France	Monitoring solution enabling customers to remotely track and monitor several items of equipment in real time, France only	Real-time expert technical support to increase equipment availability and improve performance.	ST/HE versions
M2M 1 supervision unit - International	Monitoring solution enabling customers to remotely track and monitor equipment in real time, outside of France	Real-time expert technical support to increase equipment availability and improve performance.	ST/HE versions
M2M 3 supervision units - International	Monitoring solution enabling customers to remotely track and monitor several items of equipment in real time, outside of France	Real-time expert technical support to increase equipment availability and improve performance.	ST/HE versions

SEASONAL PERFORMANCE

Most central air conditioning systems installed in the tertiary sector in Europe use water chillers to provide refrigeration. Analyses of installed systems show that heat load varies from season to season and that a water chiller operates at reduced capacity for the majority of the time.

The (European Seasonal Energy Efficiency Ratio (ESEER) measures the seasonal efficiency of water chillers by taking into account their efficiency under partial load using formulas created by the European certification body Eurovent.

Seasonal heat load variations

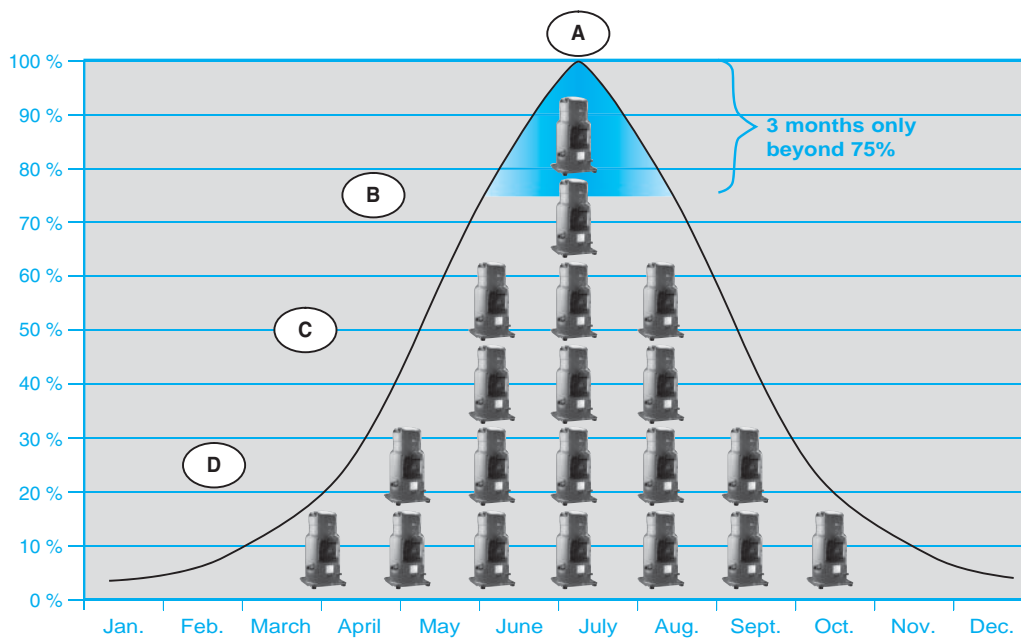

$$ESEER = A \times EER_{100\%} + B \times EER_{75\%} + C \times EER_{50\%} + D \times EER_{25\%}$$

A, B, C and D are weighting coefficients pertaining to a unit's operating time based on its load. The ESEER design conditions for air-cooled water chillers are as follows:

Load (%)	Condenser inlet air temperature (°C)	Chilled water (°C)	Energy efficiency	Weighting coefficient
100	35	12/7	EER100%	A = 0.03
75	30	10.8/7 (*)	EER75%	B = 0.33
50	25	9.5/7 (*)	EER50%	C = 0.41
25	20	8.3/7 (*)	EER25%	D = 0.23

(*) Water flow rate = Water flow rate at 100%

The efficiency under partial load is therefore essential when choosing a water chiller. It is with this in mind that the new AQUACIAT^{POWER} range was designed. In particular, the entire range uses R410A refrigerant which, thanks to its thermodynamic performance, makes it possible to obtain much higher ESEER ratings.

As its compressors are connected in parallel on the refrigeration circuit, the AQUACIAT^{POWER} easily and efficiently adjusts the cooling capacity to the system's needs. The self-adjusting Connect Touch control anticipates variations in load and starts only the number of compressors needed. This ensures optimum operation of the compressors and guarantees energy efficiency for the majority of the system's life.

The high seasonal energy efficiency AQUACIAT^{POWER} HE series has EC-type variable-speed fan motor assemblies as standard. This type of fan motor with electronic switching of poles and rotors with permanent magnets differs from standard motors fitted with a conventional frequency inverter thanks to its excellent mechanical efficiency and exceptionally low noise level, whatever the load on the shaft. This technology enables the machine's performance at partial loads to be improved, along with its ESEER.

HYDRAULIC MODULE

The "ALL-IN-ONE" solution

The PLUG & COOL solution offered by AQUACIAT^{POWER}

The hydraulic module contains all the water circuit components needed for the system to operate correctly:

- Buffer tank with 19 mm insulation, 550-litre capacity (option).
- Expansion vessel (option):
 - 50 litres for models 602C to 1000C.
 - 80 litres for models 1100C to 2000C.
- Wide selection of pumps:
 - Single or dual pumps with runtime balancing and backup.
 - High or low pressure pumps.
 - Fixed-speed or variable-speed pumps.
- Water temperature and pressure sensors.
- Water filter.
- Safety valve.
- Drain circuit.
- Air bleed valve.
- Frost protection (option).

The components in the hydraulic system are carefully selected and factory assembled and tested to make the installation of the units simple and economical.

This ensures conditioning times, implementation times and space requirements are kept to a minimum.

■ Hydraulic module

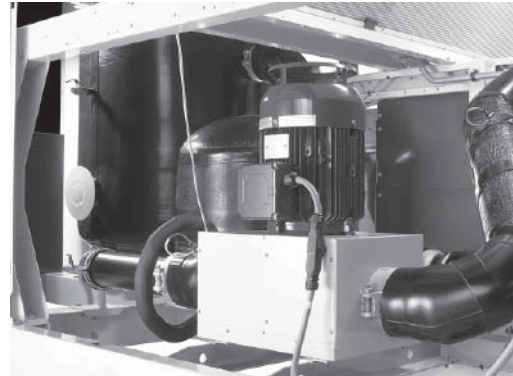

AQUACIAT^{POWER} hydraulic module diagram

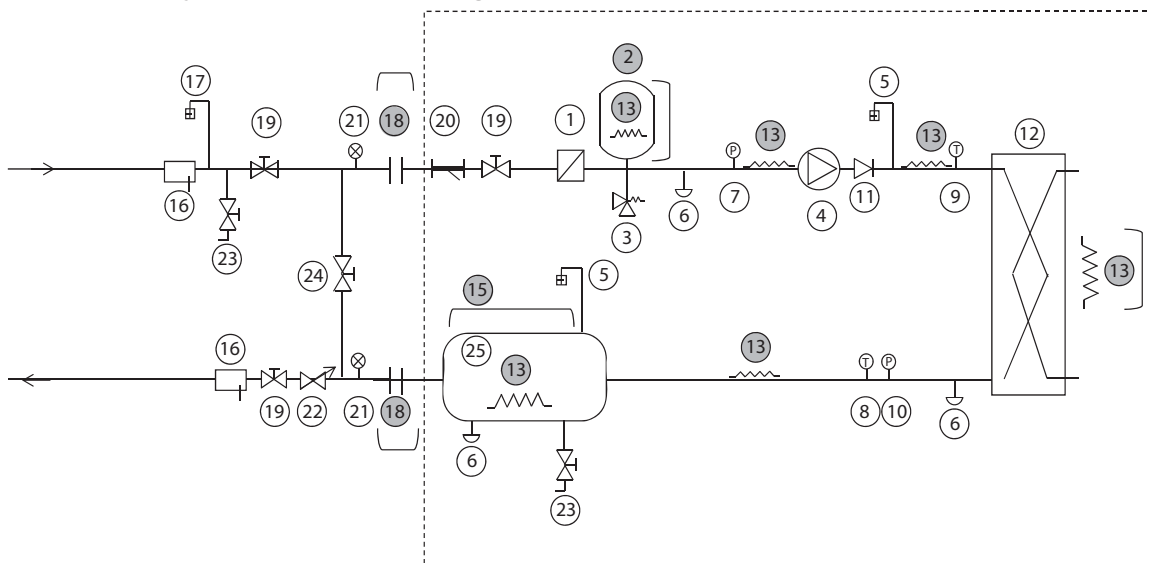

Components of the unit and hydraulic module

- 1 Screen filter (particle size of 1.2 mm)
 - 2 Expansion vessel
 - 3 Relief valve
 - 4 Circulating pump (single or dual)
 - 5 Air purge
 - 6 Water drain tap
 - 7 Pressure sensor
Note: provides information on the pump suction pressure
 - 8 Temperature sensor
Note: Provides information on the water exchanger outlet temperature
 - 9 Temperature sensor
Note: Provides information on the water exchanger inlet temperature
 - 10 Pressure sensor
Note: Provides information on the water exchanger outlet pressure
 - 11 Check valve (if dual-pump)
 - 12 Plate heat exchanger
 - 13 Heater or heat trace cable for frost protection
 - 14 Water exchanger flow rate sensor
 - 15 Buffer tank module
- Option

System components

- 16 Pocket
- 17 Air purge
- 18 Flexible connection
- 19 Shut-off valve
- 20 800 µm screen filter (Option - mandatory in the case of a unit without hydraulic module/included on hydraulic version)
- 21 Pressure differential gauge
- 22 Water flow control valve
Note: not required if hydraulic module with variable speed pump
- 23 Charge valve
- 24 Bypass valve for frost protection (if shut-off valves are closed (item 19) during winter)
- 25 Buffer tank (if required)

--- Hydraulic module (unit with hydraulic module option)

Notes:

- The system must be protected against frost.
- The unit's hydraulic module and the water exchanger may be protected against freezing (factory-fitted option) using electric heaters and heat trace cables (13)
- The pressure sensors are assembled on connections without Schraeder. Depressurise and empty the system before any work.

VARIABLE FLOW PUMP

Description

The AQUACIAT^{POWER} may be equipped with one or two variable speed pumps which save you energy by adjusting the electrical consumption of one pump to the actual requirements of a hydraulic system, in particular for oversized installations.

Simple to use

The "variable speed pump" is fully integrated on the machine, with full protection, and, as it is installed outdoors, there is no need for any work in the machine room.

The assembly is factory-fitted and pre-set on the unit; it is therefore quick to install and reduces the cost of work, in particular because there is no water flow control valve on the unit's outlet.

The ability to adjust the water flow to your requirements means that the pump pressure can be adapted precisely to the actual pressure drop on the system when it is started up on-site.

SOFT START

A SOFT START function prevents any current peaks when the pump is started up to protect the electrical system, thereby limiting the building's electricity use at peak times and ensuring the smooth operation of the pipework

STANDBY function

Lowering the speed when the compressors are on standby reduces the water flow rate to ensure the water loop is perfectly homogenised and the control temperature sensors are well irrigated. This reduces the pump's electricity consumption by around 80% during standby periods, which represents a significant proportion of the machine's normal operating time, in particular for air conditioning applications.

Operating principle

- Operation at full load

A regulator, with a direct display of the flow rate and pressure on the Connect Touch screen, enables one pump (pump A in the example below) to be adapted, by lowering its pressure P1 to the requirements of system P2, to obtain the optimal water flow rate setpoint. Electricity bills relating to the pump's consumption are reduced proportionately; this means you will see a return on investment (ROI) in only a few years, compared with the same fixed speed pump equipped with a simple flow control valve.

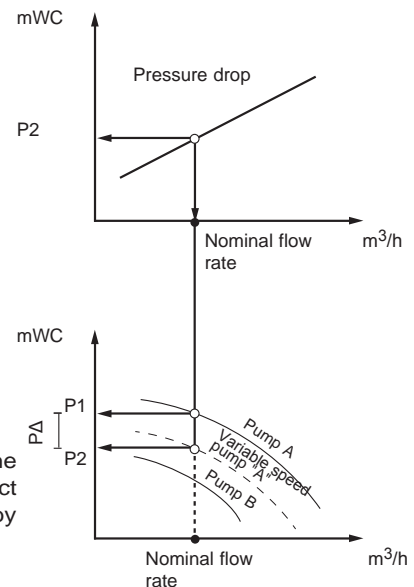

- Operation at partial load

There are three operating modes for partial load:

1 - Fixed speed

The control ensures the pump continuously runs at a constant speed, based on the capacity of the compressor(s). When the compressor is powered off, the Connect Touch "standby" function manages the electrical power consumed by the pump by reducing its speed to the minimum.

This provides energy savings of around 33%.

2 - Variable flow rate: constant regulation of the pressure difference

The control continuously acts on the pump speed to ensure a constant pressure difference. This solution is suitable for installations with two-way valves. This control mode is used to ensure a uniform supply in each hydraulic circuit to make sure that each terminal unit operates at a satisfactory pressure

3 - Variable flow rate: constant regulation of the temperature difference

The regulation maintains a constant temperature difference whatever the load rate of the unit by reducing the flow rate to the minimum acceptable limit. This control mode is suitable for most comfort applications.

This provides energy savings of around 66% for the pump in each of these last two operating modes

ENVIRONMENTAL RESPONSIBILITY

The AQUACIAT^{POWER} contributes to sustainable development via an environmentally responsible approach, aimed at balancing ecological and economic concerns. This enables it to meet the requirements of future European thermal regulations and to protect our environment for future generations.

The highly efficient performance it offers enables energy consumption to be greatly reduced, thereby reducing the unit's carbon footprint throughout its service life.

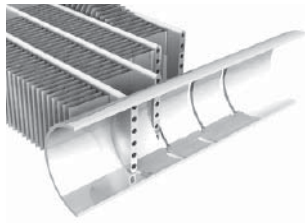

This performance is the result of the high quality components used, which have all been rigorously selected:

- The latest generation Scroll compressors
- Highly efficient R410A refrigerant, which has a low environmental impact: zero ODP (Ozone Depletion Potential), low GWP (Global Warning Potential).
- MCHE micro-channel coils
 - Energy efficiency increased by 10% compared to a conventional coil
 - 40% reduction in the refrigerant charge.
 - Reduction in the unit weight, reducing the environmental impact during transportation
 - Simplified end of life recycling thanks to the all-aluminium construction.
- Asymmetrical PBHE brazed-plate heat exchangers
 - Reduction in the refrigerant charge compared with a tubular heat exchanger solution
 - The asymmetrical technology enables a reduction in pressure drops on the water side, and an associated drop in electricity consumption.

AQUACIAT ^{POWER}		602C	650C	750C	800C	1000C	1100C	1250C	1350C	1500C	1600C	1750C	2000C
Refrigerant load	kg	21	24	24	25	26	35	36	41	43	50	50	54
Environmental impact	tCO ₂ e	43	49	49	53	55	73	74	85	90	105	105	112

Only 20% of a unit's impact on the ozone layer comes from the refrigerant (direct effect), with 80% coming from the CO₂ released into the atmosphere when the electricity required to power the unit is produced (indirect effect). With AQUACIAT^{POWER}, it's a win-win situation: its low refrigerant charge minimises the risk of emissions, and its low energy consumption limits its indirect impact.

The choice of technology used in the AQUACIAT^{POWER} range means that the TEWI, which covers the unit's environmental impact (both direct and indirect) throughout its service life, is greatly reduced.

INTEGRATION INTO THE MOST DEMANDING ENVIRONMENTS

The AQUACIAT^{POWER} has standard and optional equipment which enables it to be integrated into any one of a diverse range of environments.

In the micro-channel (MCHE) coil, the rate of corrosion is less than in a conventional coil with copper tube and aluminium fins. Indeed, its all-aluminium design limits the galvanic couples in the coil, thereby providing increased corrosion resistance.

The Protect2 anti-corrosion post-treatment option doubles its resistance to corrosion. This treatment is applied by immersing the coil, ensuring complete protection as the aluminium surface undergoes a chemical change.

This treatment is recommended for moderately corrosive environments.

The Protect4 anti-corrosion post-treatment option provides a fourfold increase in resistance to corrosion. An e-coating process is used to electro-coat the coil in polymer epoxy, and then a top layer of anti-UV protection is applied.

This treatment is recommended for highly corrosive industrial and marine environments.

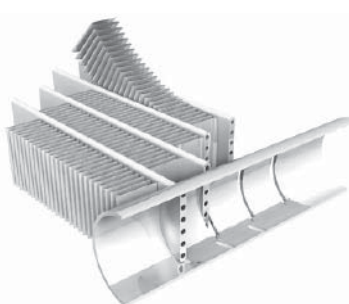

Protect2

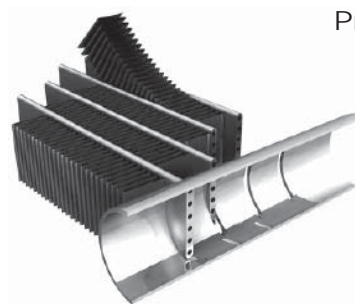

Protect4

In a polluted atmosphere, the AQUACIAT^{POWER} can be equipped with an IP54 protection option that protects the electrical components from the ingress of dust, sand and water.

TECHNICAL SPECIFICATIONS



AQUACIAT ^{POWER} LD ST			602C	650C	750C	800C	1000C	1100C	1250C	1350C	1500C	1600C	1750C	2000C	
Cooling															
Standard unit	C1	Nominal capacity	kW	168	181	198	216	261	300	331	365	397	430	464	523
Full load performance (*)	C1	EER	kW/kW	3.04	3.12	2.98	2.97	2.90	2.97	2.92	2.95	2.90	2.94	2.90	2.90
	C1	Eurovent class cooling		B	A	B	B	B	B	B	B	B	B	B	B
Seasonal efficiency (*)		ESEER	kW/kW	4.00	4.07	4.01	4.00	4.00	4.07	4.08	4.10	4.05	4.07	4.04	4.03
Partial Load integrated values		IPLV	kW/kW	4.57	4.57	4.54	4.51	4.50	4.61	4.61	4.69	4.58	4.62	4.55	4.58
Sound levels															
Standard unit															
Sound power (1)			dB(A)	91	92	92	92	92	93	93	93	93	94	94	94
Sound pressure at 10 m(2)			dB(A)	59	60	60	60	60	60	61	61	61	62	62	62
Unit + Low Noise option															
Sound power (1)			dB(A)	89	90	90	90	90	91	91	92	92	93	93	93
Sound pressure at 10 m(2)			dB(A)	57	58	58	58	58	59	59	60	60	61	61	61
Unit + Xtra Low Noise option															
Sound power			dB(A)	85	85	85	86	86	86	86	87	87	88	88	88
Sound pressure at 10 m(2)			dB(A)	53	53	53	54	54	54	54	55	55	55	55	56
Dimensions - Standard unit															
Length			mm	2410				3604				4797			
Width			mm	2253				2253				2253			
Height			mm	2297				2297				2297			
Unit + Buffer tank module option			mm	3604				4798				5991			
Operating weight (3)															
Standard unit			kg	1216	1257	1257	1387	1408	1865	1901	2069	2125	2545	2563	2761
Unit + Low Noise option			kg	1299	1339	1340	1495	1516	1991	2027	2212	2269	2707	2726	2941
Unit + Low Noise option + HP dual-pump hydraulic module			kg	1438	1479	1479	1634	1670	2151	2231	2416	2472	2950	2967	3221
Unit + Low Noise option + HP dual-pump hydraulic module + Buffer tank module			kg	2438	2479	2479	2634	2670	3151	3231	3416	3472	3950	3967	4221
Compressors															
Hermetic Scroll 48.3 r/s															
Circuit A				1	1	1	2	2	2	2	3	3	3	3	4
Circuit B				2	2	2	2	2	3	3	3	3	4	4	4
No. of control stages				3	3	3	4	4	5	5	6	6	7	7	8
Refrigerant (3)															
R410A															
Circuit A			kg	8.4	10.9	10.9	12.6	13.1	14.7	15.4	20.3	21.1	23.5	23.5	26.75
			teqCO2	17.5	22.8	22.8	26.3	27.4	30.7	32.2	42.4	44.1	49.1	49.1	55.9
Circuit B			kg	12.25	12.6	12.6	12.7	13.1	20.2	20.2	20.4	22.2	26.7	26.8	26.95
			teqCO2	25.6	26.3	26.3	26.5	27.4	42.2	42.2	42.6	46.4	55.7	56	56.3
Oil charge															
			l/ep	6.9	6.9	6.9	6.9	6.9	6.9	6.9	6.9	6.9	6.9	6.9	6.9
Control															
Connect Touch Control															
Minimum capacity			%	33%	33%	33%	25%	25%	20%	20%	17%	17%	14%	14%	13%
Air heat exchanger															
Aluminium micro-channel coils (MCHE)															
Fans - Standard unit															
Quantity				3	4	4	4	4	5	5	6	6	7	7	8
Maximum total air flow			l/s	13542	18056	18056	18056	18056	22569	22569	27083	27083	31597	31597	36111
Maximum rotation speed			r/s	16	16	16	16	16	16	16	16	16	16	16	16
Water heat exchanger															
Dual-circuit plate heat exchanger															
Water content			l	15	15	15	15	19	27	35	33	42	44	47	53
Max water-side operating pressure without hydraulic module			kPa	3200	3200	3200	3200	3200	3200	3200	3200	3200	3200	3200	3200
Hydraulic module (option)															
Pump, Victaulic screen filter, relief valve, water and air drain valve, pressure sensors, expansion vessel (option)															
Centrifugal pump, monocoil, 48.3 r/s, low or high pressure (as required), single or dual (as required)															
Expansion tank volume			l	50	50	50	50	50	80	80	80	80	80	80	80
Buffer tank volume			l	550	550	550	550	550	550	550	550	550	550	550	550
Max. water-side operating pressure with hydraulic module			kPa	400	400	400	400	400	400	400	400	400	400	400	400
Water connections with or without hydraulic module															
Victaulic® type															
Diameter			inch	3	3	3	3	3	4	4	4	4	4	4	4
External diameter			mm	88.9	88.9	88.9	88.9	88.9	114.3	114.3	114.3	114.3	114.3	114.3	114.3
Casing paint															
Colour code RAL 7035/RAL 7024															

(*) In accordance with standard EN14511-3:2013.
 C1 Cooling mode conditions: evaporator water inlet/outlet temperature 12°C/7°C, outdoor air temperature 35°C. Evaporator fouling factor 0 m². kW
 Calculation in accordance with standard AHRI 550-590
 IPLV In dB ref=10⁻¹² W, 'A' weighted. Declared dual-number noise emission values in accordance with ISO 4871 with an associated uncertainty of +/-3dB(A). Measured in accordance with ISO 9614-1 and certified by Eurovent.
 (2) In dB ref 20 µPa, 'A' weighted. Declared dual-number noise emission values in accordance with ISO 4871 with an associated uncertainty of +/-3dB(A). For information, calculated from the sound power Lw(A). Values are guidelines only. Refer to the unit name plate.
 (3) Values are guidelines only. Refer to the unit name plate.



Eurovent certified values

TECHNICAL SPECIFICATIONS



AQUACIAT ^{POWER} LD HE				602C	650C	750C	800C	1000C	1100C	1250C	1350C	1500C	1600C	1750C	2000C
Cooling															
Standard unit	C1	Nominal capacity	kW	168	180	197	216	261	300	331	365	397	430	464	523
Full load performance (*)	C1	EER	kW/kW	3.04	3.12	2.98	2.97	2.90	2.97	2.92	2.95	2.90	2.94	2.90	2.90
	C1	Eurovent class cooling		B	A	B	B	B	B	B	B	B	B	B	B
Seasonal efficiency (*)		ESEER	kW/kW	4.18	4.21	4.14	4.18	4.15	4.37	4.28	4.37	4.26	4.36	4.44	4.30
Partial Load integrated values		IPLV	kW/kW	4.76	4.85	4.73	4.85	4.75	5.00	4.83	5.00	4.81	4.92	5.00	4.84
Sound levels															
Standard unit															
Sound power (1)			dB(A)	91	92	92	92	92	93	93	93	93	94	94	94
Sound pressure at 10 m(2)			dB(A)	59	60	60	60	60	60	60	61	61	62	62	62
Unit + Low Noise option															
Sound power (1)			dB(A)	89	90	90	90	90	91	91	92	92	93	93	93
Sound pressure at 10 m(2)			dB(A)	57	58	58	58	58	59	59	60	60	61	61	61
Unit + Xtra Low Noise option															
Sound power (1)			dB(A)	85	85	85	86	86	86	86	87	87	88	88	88
Sound pressure at 10 m(2)			dB(A)	53	53	53	54	54	54	54	55	55	55	55	56
Dimensions - Standard unit															
Length			mm	2410				3604				4797			
Width			mm	2253				2253				2253			
Height			mm	2297				2297				2297			
Unit + Buffer tank module option			mm	3604				4798				5991			
Operating weight (3)															
Standard unit			kg	1252	1293	1293	1423	1445	1901	1937	2105	2162	2603	2621	2827
Unit + Low Noise option			kg	1334	1376	1376	1531	1553	2027	2063	2249	2306	2765	2783	3007
Unit + Low Noise option + HP dual-pump hydraulic module			kg	1473	1515	1516	1670	1707	2187	2267	2452	2509	3007	3024	3287
Unit + Low Noise option + HP dual-pump hydraulic module + Buffer tank module			kg	2473	2515	2516	2670	2707	3187	3267	3452	3509	4007	4024	4287
Compressors															
Hermetic Scroll 48.3 r/s															
Circuit A				1	1	1	2	2	2	2	3	3	3	3	4
Circuit B				2	2	2	2	2	3	3	3	3	4	4	4
No. of control stages				3	3	3	4	4	5	5	6	6	7	7	8
Refrigerant (3)															
R410A															
Circuit A			kg	8.40	10.90	10.90	12.60	13.10	14.70	15.40	20.30	21.10	23.50	23.50	26.75
			teqCO ₂	17.5	22.8	22.8	26.3	27.4	30.7	32.2	42.4	44.1	49.1	49.1	55.9
Circuit B			kg	12.25	12.60	12.60	12.70	13.10	20.20	20.20	20.40	22.20	26.70	26.80	26.95
			teqCO ₂	25.6	26.3	26.3	26.5	27.4	42.2	42.2	42.6	46.4	55.7	56.0	56.3
Oil charge															
			l/cp	6.9	6.9	6.9	6.9	6.9	6.9	6.9	6.9	6.9	6.9	6.9	6.9
Control															
Connect Touch Control															
Minimum capacity			%	33%	33%	33%	25%	25%	20%	20%	17%	17%	14%	14%	13%
Air heat exchanger															
Aluminium micro-channel coils (MCHE)															
Fans - Standard unit															
Quantity				3	4	4	4	4	5	5	6	6	7	7	8
Maximum total air flow			l/s	13542	18056	18056	18056	18056	22569	22569	27083	27083	31597	31597	36111
Maximum rotation speed			r/s	16	16	16	16	16	16	16	16	16	16	16	16
Water heat exchanger															
Dual-circuit plate heat exchanger															
Water content			l	15	15	15	15	19	27	35	33	42	44	47	53
Max water-side operating pressure without hydraulic module			kPa	3200	3200	3200	3200	3200	3200	3200	3200	3200	3200	3200	3200
Hydraulic module (option)															
Pump, Victaulic screen filter, relief valve, water and air drain valve, pressure sensors, expansion vessel (option)															
Pump Centrifugal pump, monocell, 48.3 r/s, low or high pressure (as required), single or dual (as required)															
Expansion tank volume			l	50	50	50	50	50	80	80	80	80	80	80	80
Buffer tank volume			l	550	550	550	550	550	550	550	550	550	550	550	550
Max. water-side operating pressure with hydraulic module			kPa	400	400	400	400	400	400	400	400	400	400	400	400
Water connections with or without hydraulic module															
Victaulic® type															
Diameter			inch	3	3	3	3	3	4	4	4	4	4	4	4
External diameter-			mm	88.9	88.9	88.9	88.9	88.9	114.3	114.3	114.3	114.3	114.3	114.3	114.3
Casing paint															
Colour code RAL 7035/RAL 7024															

(*) In accordance with standard EN14511-3:2013. (2) In dB ref 20 µPa, 'A' weighted. Declared dual-number noise emission values in accordance with ISO 4871 with an associated uncertainty of +/-3dB(A). For information, calculated from the sound power Lw(A).

C1 Cooling mode conditions: evaporator water inlet/outlet temperature 12°C/7°C, outdoor air temperature 35°C. Evaporator fouling factor 0 m². kW/W

IPLV Calculation in accordance with standard AHRI 550-590 (3) Values are guidelines only. Refer to the unit name plate.

(1) In dB ref=10⁻¹² W, 'A' weighted. Declared dual-number noise emission values in accordance with ISO 4871 with an associated uncertainty of +/-3dB(A). Measured in accordance with ISO 9614-1 and certified by Eurovent.



Eurovent certified values

ELECTRICAL SPECIFICATIONS

Basic unit (excluding pump)

AQUACIAT ^{POWER} LD HE		602C	650C	750C	800C	1000C	1100C	1250C	1350C	1500C	1600C	1750C	2000C
Power circuit													
Nominal voltage	V-ph-Hz	400 - 3 -50											
Voltage range	V	360 - 440											
Control circuit supply		24 V via internal transformer											
Nominal unit current draw (1)													
Circuit A&B	A	97	107	121	130	158	176	197	216	237	255	276	316
Maximum unit input power (2)													
Circuit A&B	kW	81	88	99	108	129	145	162	178	194	210	226	259
Cosine Phi unit at maximum power (2)		0.88	0.88	0.88	0.88	0.88	0.88	0.88	0.88	0.88	0.88	0.88	0.88
Maximum unit current draw (Un-10%) (3)													
Circuit A&B	A	142	154	173	189	227	255	284	312	340	369	397	454
Maximum unit current draw (Un) (4)													
Circuit A&B - Standard unit	A	131	142	160	174	209	235	262	287	314	340	366	419
Circuit A&B - Unit + Power factor correction option	A	98	108	123	131	161	178	201	219	241	259	281	321
Maximum start-up current, standard unit (Un) (5)													
Circuit A&B	A	305	353	371	349	420	446	472	498	525	550	577	629
Maximum start-up current, unit with soft starter (Un) (5)													
Circuit A&B	A	259	279	297	302	346	372	399	424	451	477	503	556

- (1) Conditions equivalent to the standardised Eurovent conditions (water exchanger water inlet/outlet temperature = 12°C/7°C, outdoor air temperature = 35°C).
- (2) Power input, compressors and fans, at the unit operating limits (saturated suction temperature 15°C, saturated condensing temperature 68.3°C) and nominal voltage of 400 V (data given on the unit name plate).
- (3) Maximum unit operating current at maximum unit input power and 360 V.
- (4) Maximum unit operating current at maximum input power and 400 V (values given on the unit name plate).
- (5) Maximum instantaneous start-up current at operating limits (maximum operating current of the smallest compressor(s) + fan current + locked rotor current of the largest compressor).
Fan motor electrical data: at Eurovent equivalent conditions and motor ambient air temperature of 50 °C at 400 V: 3.8 A, start-up current 20 A, power input 1.75 kW

AQUACIAT ^{POWER} LD HE		602C	650C	750C	800C	1000C	1100C	1250C	1350C	1500C	1600C	1750C	2000C
Power circuit													
Nominal voltage	V-ph-Hz	400 - 3 -50											
Voltage range	V	360 - 440											
Control circuit supply		24 V via internal transformer											
Nominal unit current draw (1)													
Circuit A&B	A	97	107	121	130	158	176	197	216	237	255	276	316
Maximum unit input power (2)													
Circuit A&B	kW	81	88	99	108	129	145	162	178	194	210	226	259
Cosine Phi unit at maximum power (2)		0.88	0.88	0.88	0.88	0.88	0.88	0.88	0.88	0.88	0.88	0.88	0.88
Maximum unit current draw (Un-10%) (3)													
Circuit A&B	A	142	154	173	189	227	255	284	312	340	369	397	454
Maximum unit current draw (Un) (4)													
Circuit A&B - Standard unit	A	131	142	160	174	209	235	262	287	314	340	366	419
Circuit A&B - Unit + Power factor correction option	A	98	108	123	131	161	178	201	219	241	259	281	321
Maximum start-up current, standard unit (Un) (5)													
Circuit A&B	A	305	353	371	349	420	446	472	498	525	550	577	629
Maximum start-up current, unit with soft starter (Un) (5)													
Circuit A&B	A	259	279	297	302	346	372	399	424	451	477	503	556

- (1) Conditions equivalent to the standardised Eurovent conditions (water exchanger water inlet/outlet temperature = 12°C/7°C, outdoor air temperature = 35°C).
- (2) Power input, compressors and fans, at the unit operating limits (saturated suction temperature 15 °C, saturated condensing temperature 68.3 °C) and nominal voltage of 400 V (data given on the unit nameplate).
- (3) Maximum unit operating current at maximum unit input power and 360 V.
- (4) Maximum unit operating current at maximum input power and 400 V (values given on the unit name plate).
- (5) Maximum instantaneous start-up current at operating limits (maximum operating current of the smallest compressor(s) + fan current + locked rotor current of the largest compressor).
Fan motor electrical data reported upstream the variable speed drive at Eurovent equivalent conditions and motor ambient air temperature of 50 °C at 400 V: Current 3.0 A; Start-up current 20 A; Power input: 1.75 kW.

ELECTRICAL SPECIFICATIONS

Short circuit current withstand capability (TN system⁽¹⁾)

AQUACIAT ^{POWER} LD ST/HE	602C	650C	800C	900C	902C	1000C	1150C	1200C	1400C	1600C	1800C	2000C
Value without upstream protection												
Short time (1 s) assigned current - I _{cw} - kA eff	8	8	8	8	8	8	15	15	15	15	20	20
Allowable peak assigned current - I _{pk} - kA pk	30	30	30	30	30	30	65	65	65	65	80	80
Value with upstream protection												
Protection type: fuse												
Conditional short circuit assigned current I _{cc} or I _{cf} - kA eff	50	50	50	50	50	50	50	50	50	50	50	50
Assigned gL/gG fuses	200	200	200	250	250	250	315	315	400	400	630	630

(1) Type of system earthing

PARTIAL RECOVERY WITH DESUPERHEATER

The AQUACIAT^{POWER} range may be equipped as an option with an energy recovery function using a desuperheater

Heat from gases released by the compressors is recovered directly by a type of heat exchanger called a desuperheater located on the unit to produce free, additional hot water.

This optional configuration requires assembly in our factories and is by order only.

■ Refrigerating circuit diagram

This refrigeration diagram illustrates a unit with a desuperheater on each refrigerating circuit. For heat recovery to be possible, the unit must be operating. For the same cooling capacity, the desuperheater provides a source of free hot water and lowers the unit's electrical power consumption.

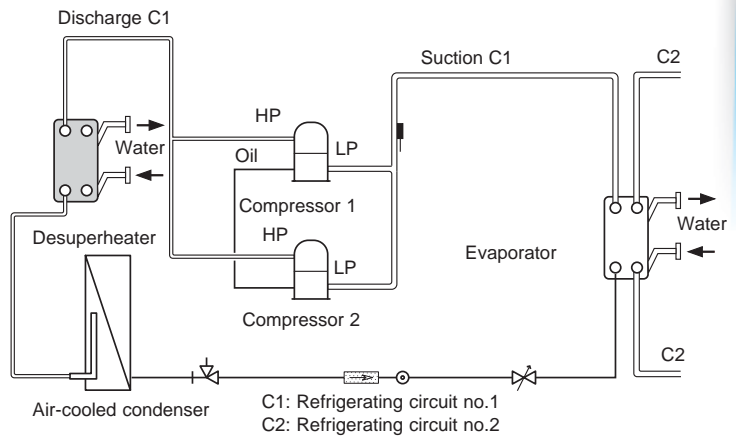

■ Hydraulic connections: configuration and precautions

The hydraulic supply for each desuperheater is delivered in parallel. In order to ensure that the unit can start and operate under the correct conditions, the desuperheater circuit water loop must be as short as possible and be able to increase quickly in temperature. The minimum desuperheater water inlet temperature must be 25°C. It may require the use of a three-way valve with its controller and a sensor controlling the minimum water inlet temperature.

Note:

The water loop for the desuperheater circuit must include an expansion vessel and a valve. Special attention should be paid when selecting the expansion vessel as the recovery water circuit can reach 120°C if the pump is turned off or if no hot water is consumed

■ Operating limits

Desuperheater		Minimum	Maximum
Water inlet temperature at start-up	°C	25	60
Leaving water temperature during operation	°C	30	80
Air condenser		Minimum	Maximum
Outdoor air temperature during operation	°C	0(*)	46

(*) - 20°C with the all-season operation option on the ST version
 - 20°C as standard on the HE version

PARTIAL RECOVERY WITH DESUPERHEATER



■ Technical specifications

AQUACIAT ^{POWER} LD ST/HE		602C	650C	750C	800C	1000C	1100C	1250C	1350C	1500C	1600C	1750C	2000C
Partial heat recovery on the A/B circuits		Plate heat exchanger											
Water volume circuits A/B	l	2/3.75	2/3.75	2/3.75	3.75/3.75	3.75/3.75	3.75/5.5	3.75/5.5	5.5/5.5	5.5/5.5	5.5/7.5	5.5/7.5	7.5/7.5
Maximum operating pressure, water side	kPa	1000	1000	1000	1000	1000	1000	1000	1000	1000	1000	1000	1000
Refrigerant		R410A											
Circuit A (1)	kg	9.1	13.4	12.9	14.3	13.6	15.0	17.3	22.8	21.4	26.3	23.7	27.3
	teqCO ₂	19.1	27.9	26.9	30.0	28.4	31.3	36.1	47.6	44.7	54.9	49.6	57.0
Circuit B (1)	kg	13.5	14.3	13.3	14.5	13.6	22.8	21.1	20.9	22.4	27.4	27.3	27.5
	teqCO ₂	28.1	30.0	27.7	30.2	28.4	47.6	44.1	43.7	46.8	57.1	57.1	57.4
Water connections		Victaulic®											
Connection	inches	2»	2»	2»	2»	2»	2»	2»	2»	2»	2»	2»	2»
External diameter	mm	60,3	60,3	60,3	60,3	60,3	60,3	60,3	60,3	60,3	60,3	60,3	60,3
AQUACIAT^{POWER} LD ST													
Operating weight (1)													
Unit + Partial heat recovery option	kg	1269	1310	1311	1446	1467	1932	1968	2143	2201	2626	2643	2849
Unit + Low Noise-Xtra Low Noise option + Partial heat recovery	kg	1352	1393	1394	1554	1575	2058	2094	2287	2344	2788	2805	3029
Unit + Low Noise-Xtra Low Noise option + HP dual-pump hydraulic module option + Partial heat recovery	kg	1491	1533	1533	1693	1729	2218	2298	2491	2548	3032	3049	3309
AQUACIAT^{POWER} LD HE													
Operating weight (1)													
Unit + Partial heat recovery option	kg	1305	1347	1347	1482	1504	1969	2004	2180	2237	2683	2700	2915
Unit + Low Noise-Xtra Low Noise option + Partial heat recovery	kg	1388	1430	1430	1590	1612	2095	2130	2323	2381	2845	2862	3095
Unit + Low Noise-Xtra Low Noise option + HP dual-pump hydraulic module option + Partial heat recovery	kg	1527	1569	1569	1729	1766	2254	2334	2528	2584	3089	3106	3375

(1) Weights are guidelines only. Refer to the unit name plate.

■ Performance

AQUACIAT ^{POWER} LD ST/HE		602C	650C	750C	800C	1000C	1100C	1250C	1350C	1500C	1600C	1750C	2000C
Total heating capacity	kW	223	239	264	289	352	401	444	489	534	577	624	704
Recovered capacity (45-55)	kW	49.8	53.3	59.6	69.1	78.9	108.1	120.5	132.4	144.7	156.5	169.6	191.4
% recovery	%	22%	22%	23%	24%	22%	27%	27%	27%	27%	27%	27%	27%
Water flow rate	l/s	1.2	1.3	1.4	1.7	1.9	2.6	2.9	3.2	3.5	3.8	4.1	0.0
Pressure drop of water flow	kPa	4.6	5.2	6.4	8.4	10.7	10.9	13.4	8.4	9.9	11.5	13.3	16.8
Recovered capacity (50-60)	kW	42.9	45.8	51.2	57.4	68	89.9	100.3	110.4	120.6	125.6	136	153.6
% recovery	%	19%	19%	19%	20%	19%	22%	23%	23%	23%	22%	22%	22%
Water flow rate	l/s	1.0	1.1	1.2	1.4	1.7	2.2	2.4	2.7	2.9	3.0	3.3	3.7
Pressure drop of water flow	kPa	3.4	3.9	4.7	5.8	8.0	7.7	9.4	5.8	6.9	7.4	8.6	10.9
Recovered capacity (55-65)	kW	33.6	35.9	40.2	45.4	53.3	70.7	78.8	86.6	94.6	97.9	106.1	119.7
% recovery	%	15%	15%	15%	16%	15%	18%	18%	18%	18%	17%	17%	17%
Water flow rate	l/s	0.8	0.9	1.0	1.1	1.3	1.7	1.9	2.1	2.3	2.4	2.6	2.9
Pressure drop of water flow	kPa	2.1	2.4	3	3.7	5	4.8	5.9	3.6	4.3	4.6	5.3	6.7

Performance for the chilled water temperature = 12°C/7°C and outdoor air temperature = 35°C

INTELLIGENTLY DESIGNED ACOUSTICS

To comply with the various integration restrictions, the AQUACIAT^{POWER} has three sound finish levels enabling it to be easily integrated into a number of zones without causing disruption to users or their neighbours.

■ Basic version

The distinguishing feature of the AQUACIAT^{POWER} range is its rigorous design incorporating "noiseless" assembly techniques to reduce vibrations and sources of noise:

- New generation scroll compressors with a continuous scrolling motion to lessen vibrations
- Compressor structure separated from the unit by anti-vibration mounts
- Pipes separated from the unit structure
- Fans made from a synthetic material, with aerodynamic blades offering an optimised profile. Optimised coil-fan combination, the result of many hours of study of the thermal and acoustic properties in our Research and Innovation Centre, to ensure a linear flow of air without turbulence, to limit noise to an acceptable acoustic spectrum.
- The Connect Touch controller automatically adjusts the fan air flow rate according to the outdoor air temperature and the unit's load rate which enables the noise level to be significantly reduced, particularly at night, mid-season, morning and evening, which totals more than 75% of the time the unit is used.

■ Low Noise option

In this version, in addition to the basic equipment, the compressors are placed in sound boxes equipped with absorbent materials limiting the level of noise radiated by the machine.

■ Xtra Low Noise option

In this version, the compressors are housed in sound boxes identical to those in the Low Noise version and the fan rotation speed is reduced whilst ensuring the output and thermal performance remain optimised.

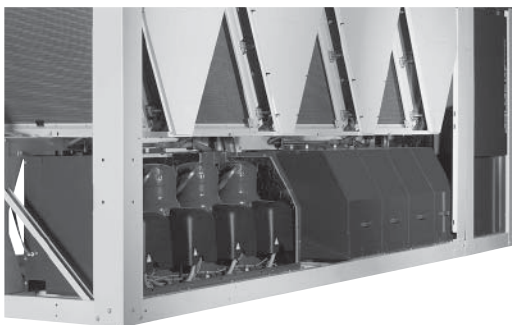

■ Night mode

The AQUACIAT^{POWER} has a Night Mode enabling the noise level to be limited at night or when the building is unoccupied (according to the user programming) by controlling the output and the fan rotation speed.

■ Acoustic signature

As important as the sound power level, the acoustic signature reflects the noise disturbance generated by the unit.

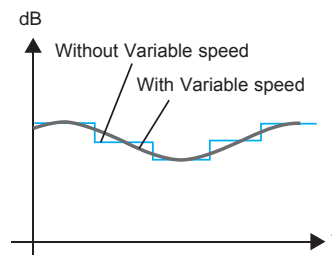
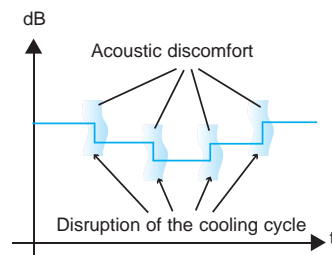

The AQUACIAT^{POWER} HE series has EC-type variable-speed motors on the fan motor assemblies as standard.

The AQUACIAT^{POWER} ST series units equipped with an EC motor option (all-season operation) have one EC fan motor assembly per coil.

In addition to electrical performance, the EC motor also enables soft start for the fans. It avoids the increases in noise linked to the on/off sequences, thereby improving the unit's acoustic signature.

Similarly, the installation of a variable speed pump enables the noise level of the pump function to be reduced by adjusting the pump speed to what is strictly necessary. The soft start improves the signature and reduces nuisance noise.

With all these benefits and its three acoustic finish levels (Standard, Low Noise and Xtra Low Noise), the AQUACIAT^{POWER} can be integrated into any site, ensuring any constraints in terms of the sound environment can be met.

SOUND LEVELS

Standard ST - High Efficiency HE versions

■ Sound power levels ref 10^{-12} W ± 3 dB (L_w)

At nominal EN 14511-3: 2013 operating conditions in cooling mode

AQUACIAT ^{POWER} LD ST/HE	SOUND POWER LEVEL SPECTRUM (dB)						Overall power level dB(A)
	125 Hz	250 Hz	500 Hz	1000 Hz	2000 Hz	4000 Hz	
602C	92	89	90	86	81	77	91
650C	93	90	91	87	81	78	92
750C	93	90	91	87	81	78	92
800C	93	91	91	87	82	78	92
1000C	93	91	91	87	82	78	92
1100C	93	91	92	88	82	79	93
1250C	93	91	92	88	82	79	93
1350C	94	92	92	89	83	79	93
1500C	94	92	92	89	83	79	93
1600C	95	92	93	89	84	80	94
1750C	95	92	93	89	84	80	94
2000C	95	92	93	89	84	80	94

■ Sound pressure levels ref 2×10^{-5} Pa ± 3 dB (L_p)

Measurement conditions: free field, 10 metres from machine, 1.50 metres above floor level, directivity 2

AQUACIAT ^{POWER} LD ST/HE	SOUND PRESSURE SPECTRUM (dB) Std						Overall pressure level dB(A)
	125 Hz	250 Hz	500 Hz	1000 Hz	2000 Hz	4000 Hz	
602C	60	57	58	55	49	45	59
650C	61	58	59	55	49	46	60
750C	61	58	59	55	49	46	60
800C	61	59	59	55	50	46	60
1000C	61	59	59	55	50	46	60
1100C	61	59	59	56	50	46	60
1250C	61	59	59	56	50	46	60
1350C	62	60	60	56	51	47	61
1500C	62	60	60	56	51	47	61
1600C	62	60	61	57	51	48	62
1750C	62	60	61	57	51	48	62
2000C	62	60	61	57	51	48	62

NB: Sound pressure levels depend on the installation conditions of each system. As such, the levels listed here are given for information only. Only the sound power levels are comparable and certified.

SOUND LEVELS

Standard ST - High Efficiency HE LOW NOISE option versions

■ Sound power levels ref 10^{-12} W ± 3 dB (L_w)

At nominal EN 14511-3: 2013 operating conditions in cooling mode

AQUACIAT ^{POWER} LD ST/HE	SOUND POWER LEVEL SPECTRUM (dB)						Overall power level dB(A)
	125 Hz	250 Hz	500 Hz	1000 Hz	2000 Hz	4000 Hz	
602C	91	88	87	85	79	76	89
650C	92	89	88	86	80	77	90
750C	92	89	88	86	80	77	90
800C	92	89	88	86	80	77	90
1000C	92	89	88	86	80	77	90
1100C	93	90	89	87	81	78	91
1250C	93	90	89	87	81	78	91
1350C	94	91	90	88	82	79	92
1500C	94	91	90	88	82	79	92
1600C	95	92	91	88	83	80	93
1750C	95	92	91	88	83	80	93
2000C	95	92	91	88	83	80	93

■ Sound pressure levels ref 2×10^{-5} Pa ± 3 dB (L_p)

Measurement conditions: free field, 10 metres from machine, 1.50 metres above floor level, directivity 2

AQUACIAT ^{POWER} LD ST/HE	SOUND PRESSURE SPECTRUM (dB) Opt Low Noise						Overall pressure level dB(A)
	125 Hz	250 Hz	500 Hz	1000 Hz	2000 Hz	4000 Hz	
602C	59	56	55	53	47	44	57
650C	60	57	56	54	48	45	58
750C	60	57	56	54	48	45	58
800C	60	57	56	54	48	45	58
1000C	60	57	56	54	48	45	58
1100C	61	58	57	55	49	46	59
1250C	61	58	57	55	49	46	59
1350C	62	59	58	55	50	47	60
1500C	62	59	58	55	50	47	60
1600C	63	60	58	56	50	47	61
1750C	63	60	58	56	51	47	61
2000C	63	60	59	56	51	47	61

NB: Sound pressure levels depend on the installation conditions of each system. As such, the levels listed here are given for information only. Only the sound power levels are comparable and certified.

SOUND LEVELS

Standard ST - High Efficiency HE XTRA LOW NOISE option versions

■ Sound power levels ref 10^{-12} W ± 3 dB (L_w)

Nominal EN 14511-3: 2013 operating conditions in cooling mode

AQUACIAT ^{POWER} LD ST/HE	SOUND POWER LEVEL SPECTRUM (dB)						Overall power level dB(A)
	125 Hz	250 Hz	500 Hz	1000 Hz	2000 Hz	4000 Hz	
602C	83	86	83	80	76	69	85
650C	84	85	83	80	76	69	85
750C	84	85	83	80	76	69	85
800C	85	87	84	81	77	70	86
1000C	85	87	84	81	77	70	86
1100C	84	87	84	81	77	70	86
1250C	84	87	84	81	77	70	86
1350C	85	88	85	82	78	71	87
1500C	85	88	85	82	78	71	87
1600C	86	88	86	82	79	72	88
1750C	86	88	86	82	79	72	88
2000C	87	89	86	83	79	72	88

■ Sound pressure levels ref 2×10^{-5} Pa ± 3 dB (L_p)

Measurement conditions: free field, 10 metres from machine, 1.50 metres above floor level, directivity 2

AQUACIAT ^{POWER} LD ST/HE	SOUND PRESSURE SPECTRUM (dB) Opt Xtra Low Noise						Overall pressure level dB(A)
	125 Hz	250 Hz	500 Hz	1000 Hz	2000 Hz	4000 Hz	
602C	51	54	51	48	44	37	53
650C	52	53	51	48	44	37	53
750C	52	53	51	48	44	37	53
800C	52	55	52	49	45	38	54
1000C	52	55	52	49	45	38	54
1100C	52	54	52	49	45	38	54
1250C	52	54	52	49	45	38	54
1350C	53	55	53	50	46	39	55
1500C	53	55	53	50	46	39	55
1600C	54	56	53	50	46	40	55
1750C	54	56	53	50	46	40	55
2000C	54	56	54	50	47	40	56

NB: Sound pressure levels depend on the installation conditions of each system. As such, the levels listed here are given for information only. Only the sound power levels are comparable and certified.

SYSTEM WATER VOLUME - EVAPORATOR WATER FLOW RATE

The Connect Touch controller is equipped with anticipation logic making it highly flexible in adjusting operation to parameter drift, particularly on hydraulic systems with low water volumes. By adjusting compressor running times, it prevents short-cycle protection cycles from starting and, in most cases, eliminates the need for a buffer tank.

Note: The minimum volumes of chilled water are calculated for EUROVENT rated conditions:

- Chilled water temperature = 12°C/7°C
- Condenser air inlet temperature = 35°C

This value is applicable for most air conditioning applications (unit with fan coil units).

Note:

For installations running with a low volume of water (assembly with air handling unit) or for industrial processes, the buffer tank is a required component.

AQUACIAT ^{POWER} LD ST/HE	602C	650C	750C	800C	1000C	1100C	1250C	1350C	1500C	1600C	1750C	2000C	
Minimum system water volume, air conditioning application (litres)	420	451	494	539	654	750	827	914	993	1076	1159	1306	
Minimum system water volume, industrial process application (litres)	1091	1173	1283	1401	1699	1949	2150	2375	2582	2796	3014	3396	
Min(1)/max(2) water exchanger flow rate without hydraulic module (l/s)	2.9/17.5	3.2/17.5	3.6/17.5	3.8/17.5	4.6/21.8	5.2/29.8	5.9/35.2	6.3/33.8	7.1/38.9	7.6/40.4	8.2/41.6	9.4/43.4	
Water exchanger flow rate with low pressure hydraulic module (l/s)	Min(3)/max single	2.8/12.2	2.8/12.2	2.8/12.2	2.8/12.2	4/14.3	3.1/20.2	3.4/20.2	3.7/20.2	9.5/25	9.5/25	9.5/25	5.4/26.6
	Min(3)/max dual	3.2/10.3	3.2/10.3	2.5/12.2	2.5/12.2	2.7/15	3.7/20.2	3.7/20.2	3.8/20.2	4.1/25	8/25	8/25	5.4/26.5
Water exchanger flow rate with high pressure hydraulic module (l/s)	Min(3)/max single	2.5/11.7	2.5/11.7	2.5/11.7	2.5/11.7	5.2/16.1	6.4/16.1	3.6/26.5	3.7/26.5	4.1/26.5	4.4/26.7	4.8/26.7	5.4/26.7
	Min(3)/max dual	2.6/11.7	2.6/11.7	2.6/11.7	2.6/11.7	2.9/15.5	3.5/15.5	3.4/26.5	3.7/26.5	4.1/26.5	4.4/29.2	4.8/29.2	5.4/35

(1) Minimum flow rate for maximum allowable water temperature difference conditions (10°C)

(2) Maximum flow rate for a pressure drop of 100 kPa in the plate heat exchanger

(3) Minimum factory flow rate setting according to the type of pump

NOTE: For the Buffer Tank Module option, the volume of the tank must be taken into account (550 litres)

OPERATING RANGE

The AQUACIAT^{POWER} units have a broad field of application, enabling them to meet a range of requirements in the most varied of climates.

Multi-climate: -20°C to +48°C

The AQUACIAT^{POWER} HE series is equipped as standard with all the management devices and algorithms to enable all-season operation in all climates. The AQUACIAT^{POWER} HE series is therefore able to operate in conditions ranging from the heat of the Mediterranean basin to the chill of Scandinavia, the humid Atlantic coast to the dry climate of Central Europe.

In the ST series, all-season operation down to - 20°C is optional (standard 0°C).

Multi-application: air conditioning, industrial processes

The AQUACIAT^{POWER} can be used for all traditional air conditioning applications in sectors as varied as shared residency, hotels, shopping centres and offices.

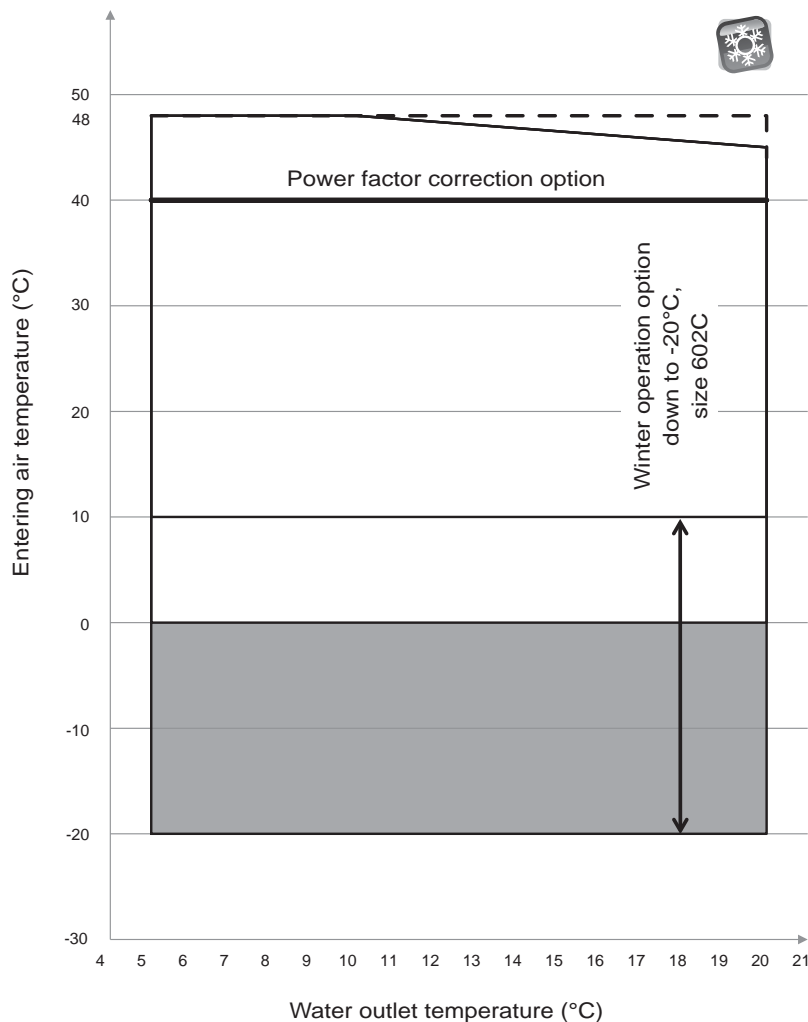

- LD ST/HE full load
- ST version winter operation option (standard HE version)
- Partial load

Power factor correction option available for an inlet air temperature up to +40°C
 For operation in pure water at an inlet air temperature below 0°C, the frost protection option must be provided

HYDRAULIC SPECIFICATIONS

■ Water pressure drop in the evaporator

Data applicable for pure water at 20°C

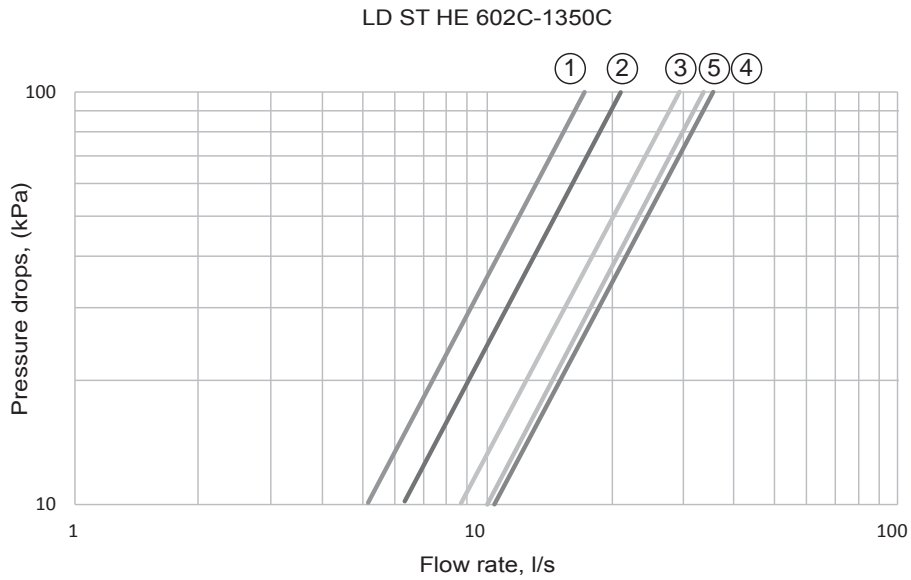

- ① LD 602C-800C
- ② LD 1000C
- ③ LD 1100C
- ④ LD 1250C
- ⑤ LD 1350C

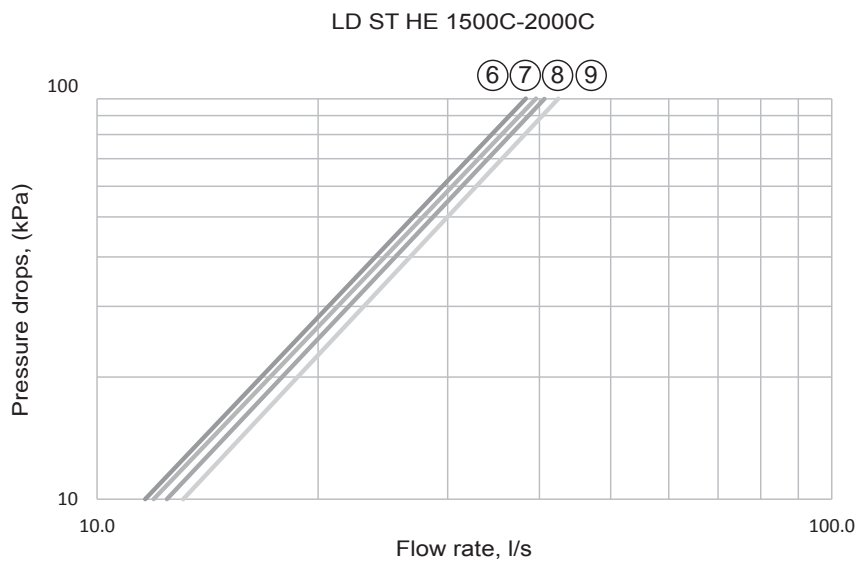

- ⑥ LD 1500C
- ⑦ LD 1600C
- ⑧ LD 1750C
- ⑨ LD 2000C

■ Water pressure drop in the filter

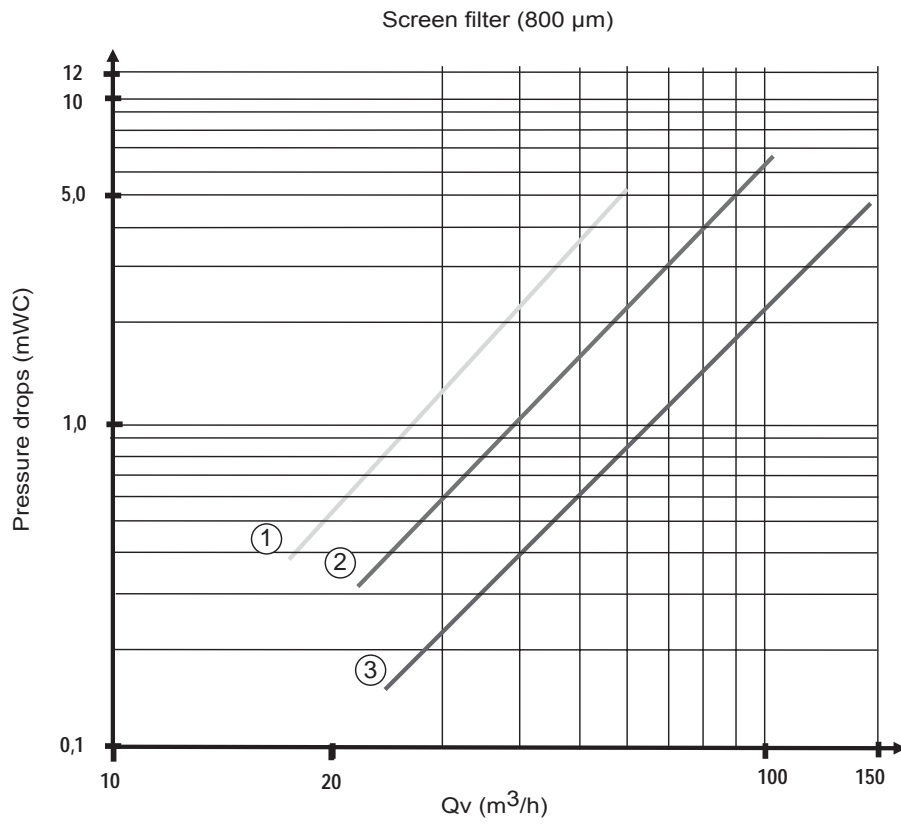

- ① LD 602C - 650C
- ② LD 750C - 1100C
- ③ LD 1250C - 2000C

HYDRAULIC SPECIFICATIONS

■ Available static pressure for the system

Data applicable for:

- Pure water at 20°C
- Refer to the section "Evaporator water flow rate" for the minimum and maximum water flow rate values
- If a glycol/water mix is used, the maximum water flow rate is reduced

■ LD ST/HE high pressure pumps (fixed or variable speed at 50 Hz)

Single pumps

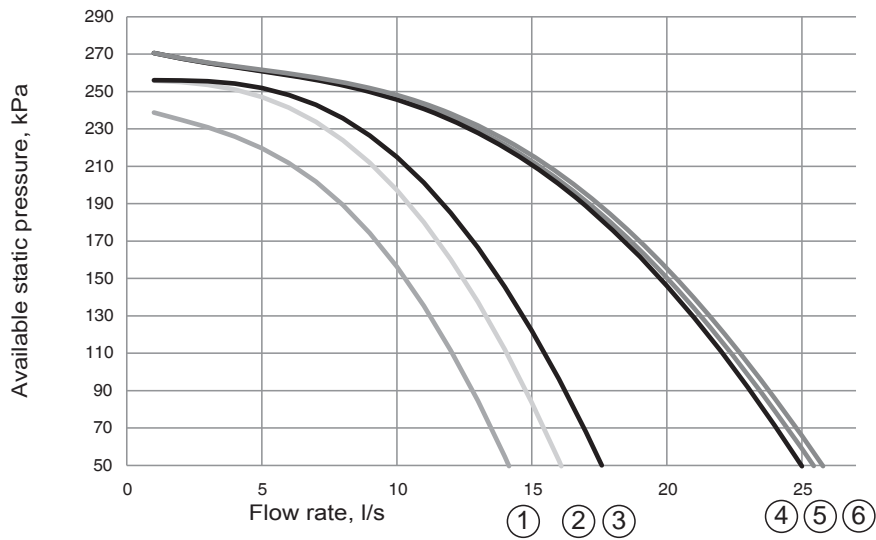

- ① LD 602C-800C
- ② LD 1000C
- ③ LD 1100C

- ④ LD 1350C
- ⑤ LD 1250C
- ⑥ LD 1500C

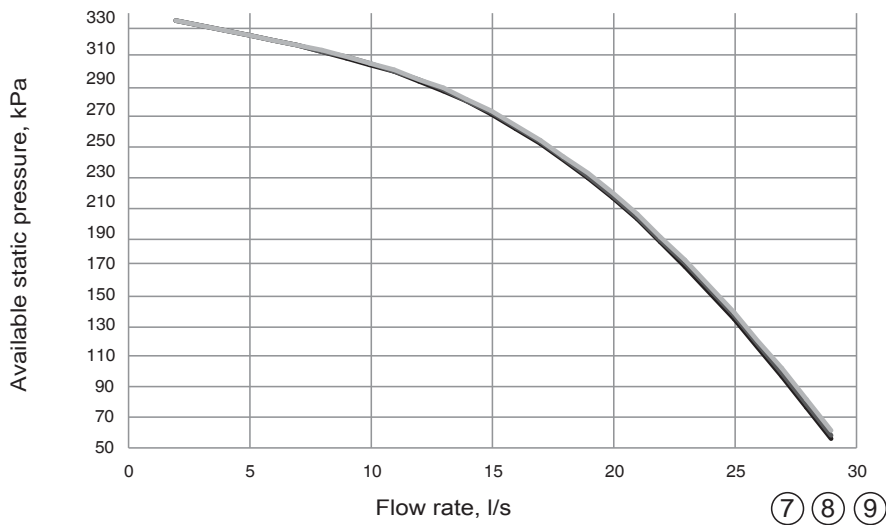

- ⑦ LD 1600C
- ⑧ LD 1750C
- ⑨ LD 2000C

■ LD ST/HE high-pressure pumps (fixed or variable speed at 50 Hz)

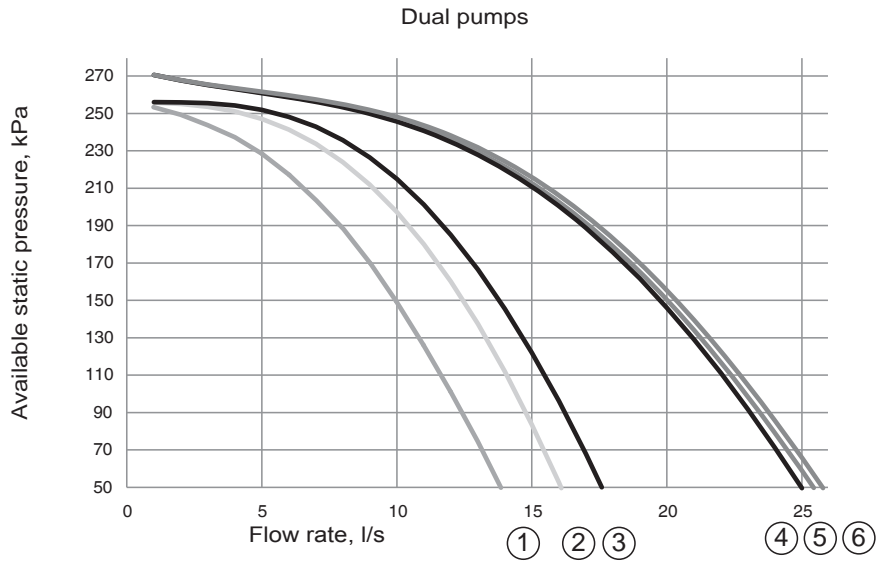

- ① LD 602C - 800C
- ② LD 1000C
- ③ LD 1100C

- ④ LD 1350C
- ⑤ LD 1250C
- ⑥ LD 1500C

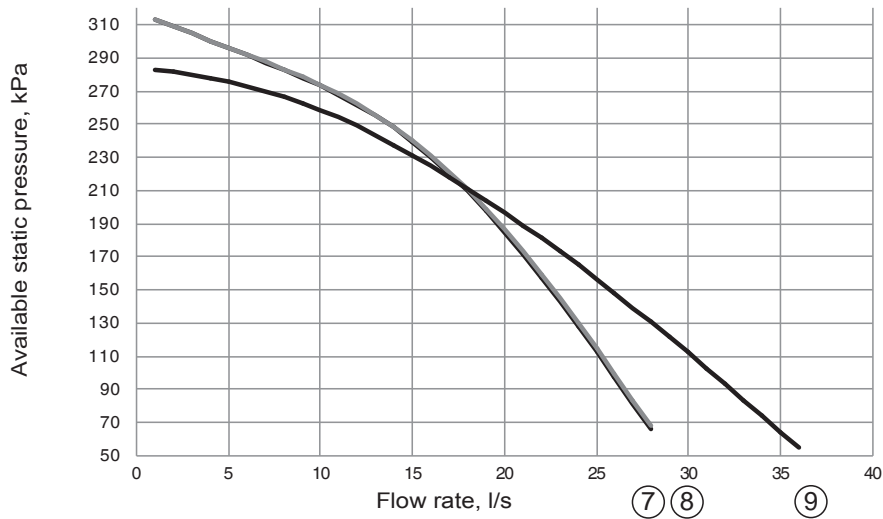

- ⑦ LD 1600C
- ⑧ LD 1750C
- ⑨ LD 2000C

HYDRAULIC SPECIFICATIONS

■ Available static pressure for the system

Data applicable for:

- Pure water at 20°C
- Refer to the section "Evaporator water flow rate" for the minimum and maximum water flow rate values
- If a glycol/water mix is used, the maximum water flow rate is reduced

■ LD ST/HE low-pressure pumps (fixed speed)

Single pumps

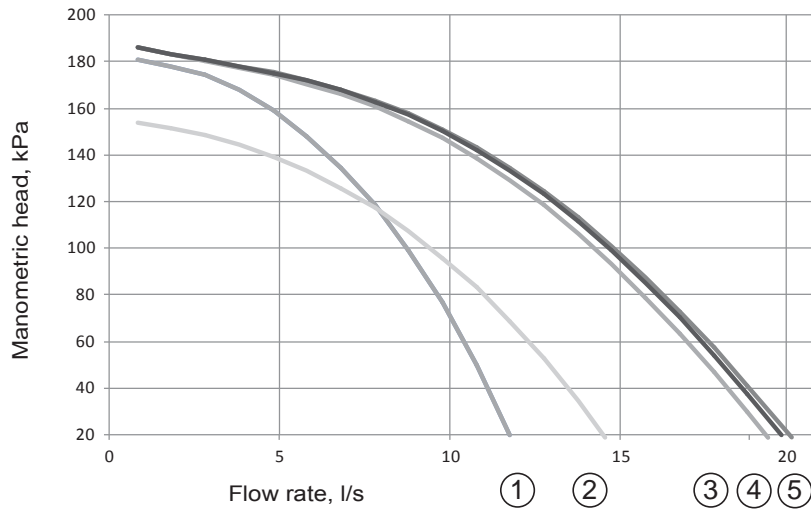

- ① LD 602C - 800C
- ② LD 1000C
- ③ LD 1100C

- ④ LD 1350C
- ⑤ LD 1250C

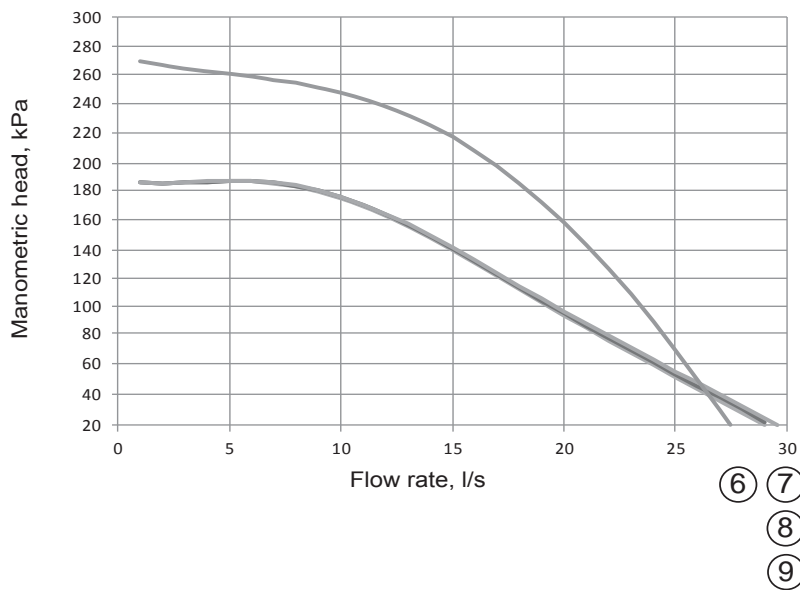

- ⑥ LD 2000C
- ⑦ LD 1500C

- ⑧ LD 1600C
- ⑨ LD 1750C

■ LD ST/HE low-pressure pumps (fixed speed)

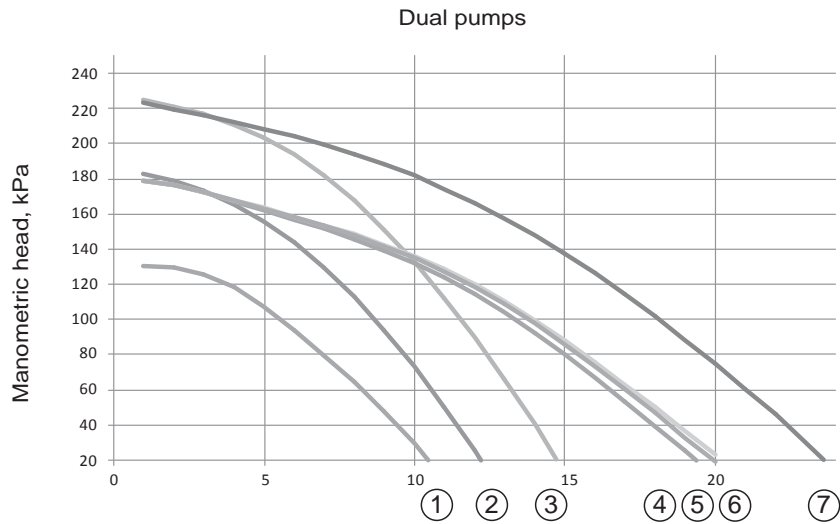

- ① LD 602C - 650C
- ② LD 750C - 800C
- ③ LD 1000C
- ④ LD 1100C

- ⑤ LD 1250C
- ⑥ LD 1350C
- ⑦ LD 1500C

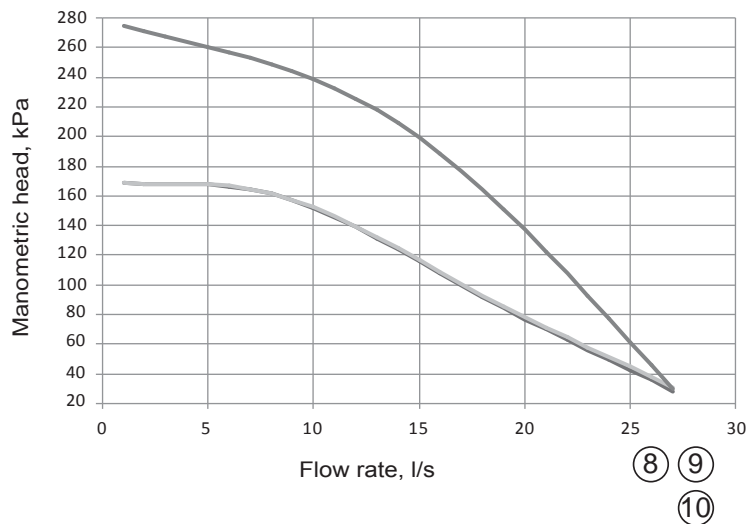

- ⑧ LD 2000C
- ⑨ LD 1600C
- ⑩ LD 1750C

DIMENSIONS

AQUACIAT^{POWER} LD ST-HE 602C to 1000C without buffer tank

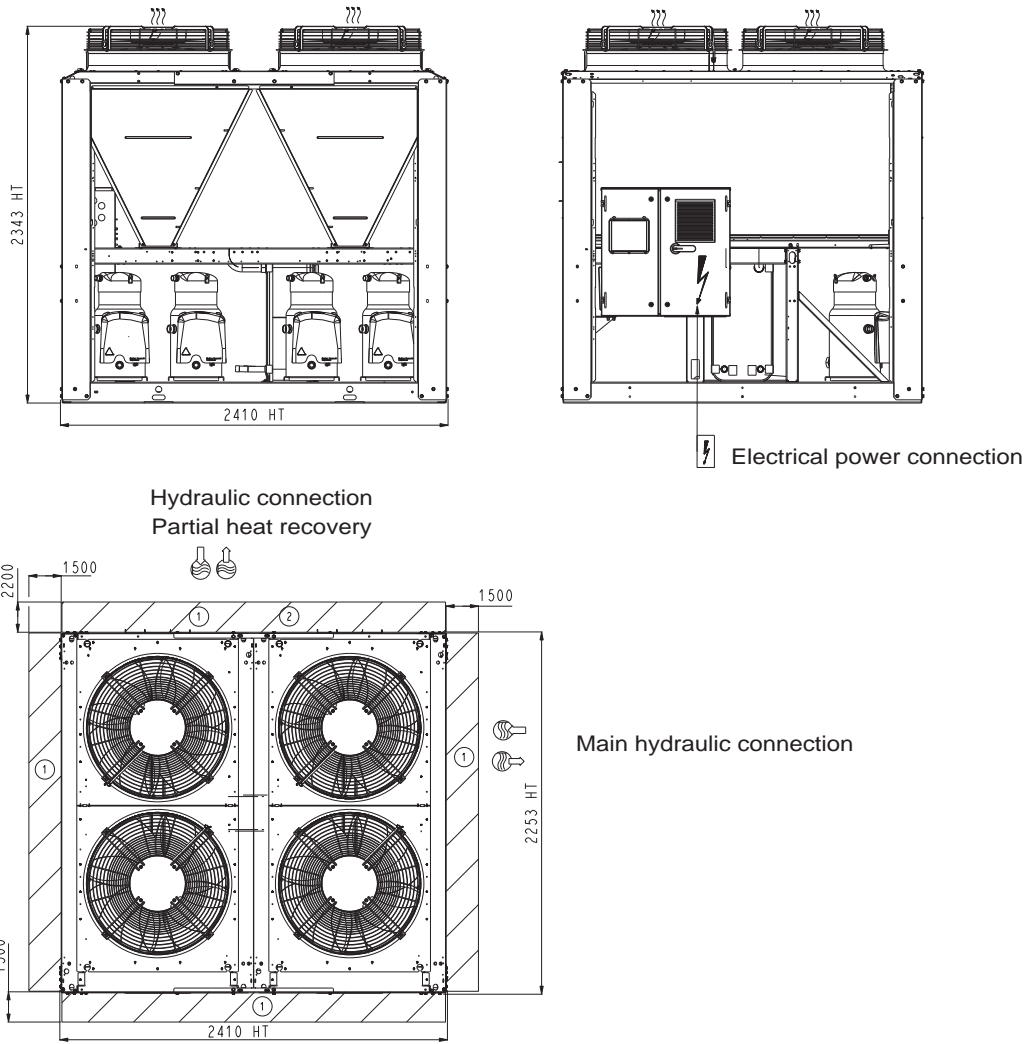

Key
All dimensions in mm

- ① Clearance required for maintenance and air flow
- ② Clearance recommended for coil removal
- Water inlet
- Water outlet
- Air outlet, do not obstruct
- Electrical cabinet

Notes:
Non-contractual drawings.

When designing a system, refer to the certified dimensional drawings provided with the unit or available on request.

Please refer to the certified dimensional drawings for the positioning of the fixing points, weight distribution points and centre of gravity coordinates.

DIMENSIONS

AQUACIAT^{POWER} LD ST-HE 602C to 1000C with buffer tank

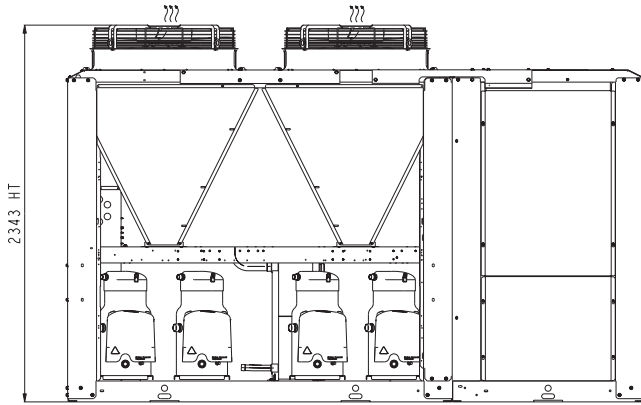

Main hydraulic connection

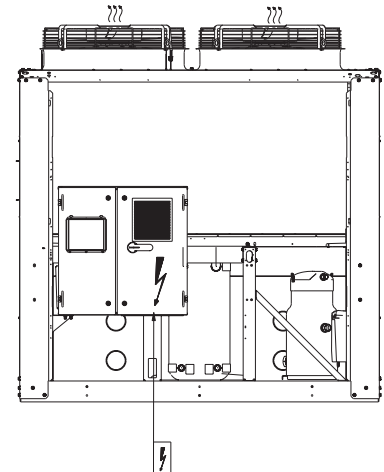

Electrical power connection

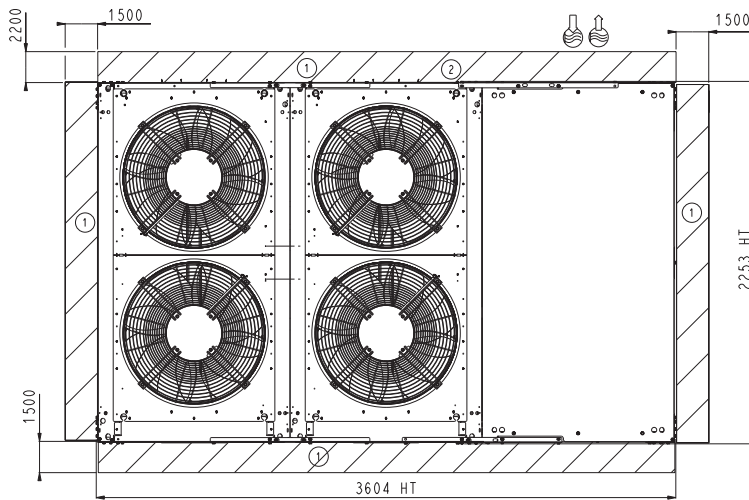

Key
All dimensions in mm

- ① Clearance required for maintenance and air flow
- ② Clearance recommended for coil removal
- Water inlet
- Water outlet
- Air outlet, do not obstruct
- Electrical cabinet

Notes:
Non-contractual drawings.

When designing a system, refer to the certified dimensional drawings provided with the unit or available on request.

Please refer to the certified dimensional drawings for the positioning of the fixing points, weight distribution points and centre of gravity coordinates.

DIMENSIONS

AQUACIAT^{POWER} LD ST-HE 1100C to 1500C without buffer tank

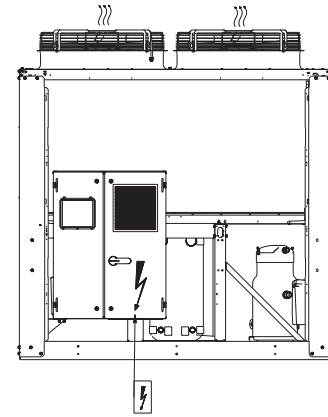
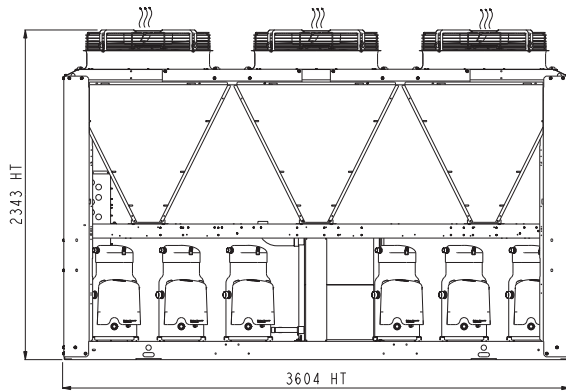

Electrical power connection

Hydraulic connection
Partial heat recovery

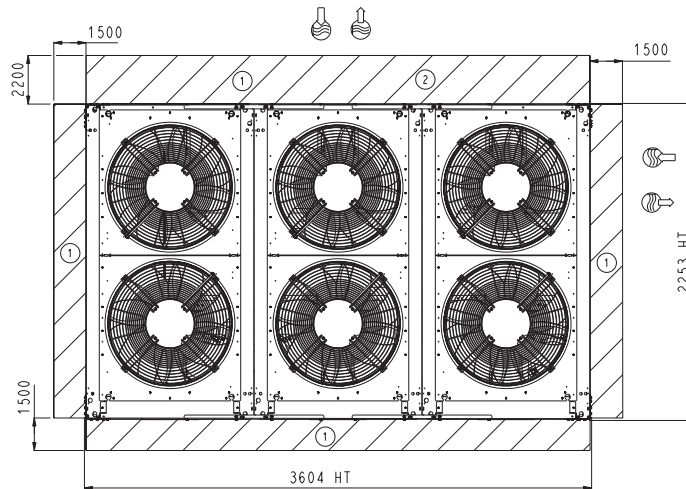

Main hydraulic connection

Key
All dimensions in mm

- ① Clearance required for maintenance and air flow
- ② Clearance recommended for coil removal
- Water inlet
- Water outlet
- Air outlet, do not obstruct
- Electrical cabinet

Notes:
Non-contractual drawings.

When designing a system, refer to the certified dimensional drawings provided with the unit or available on request.

Please refer to the certified dimensional drawings for the positioning of the fixing points, weight distribution points and centre of gravity coordinates.

DIMENSIONS

AQUACIAT^{POWER} LD ST-HE 1100C to 1500C with buffer tank

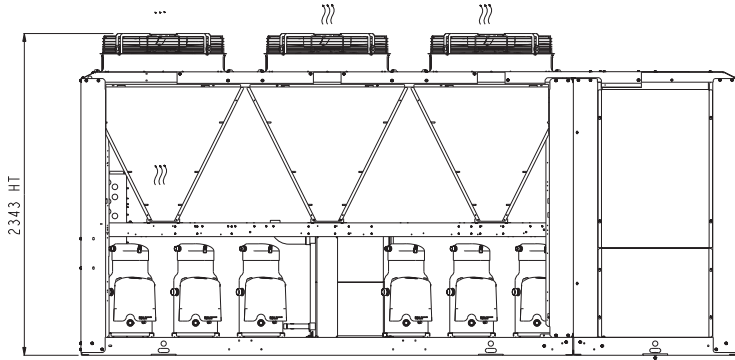

Main hydraulic connection

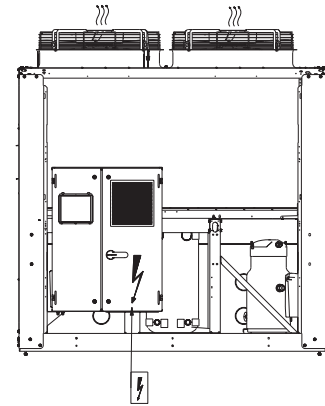

Electrical power connection

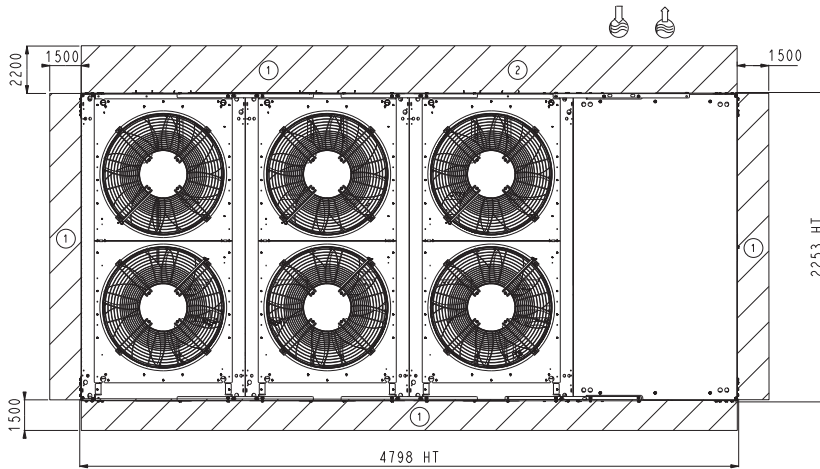

Key
All dimensions in mm

- ① Clearance required for maintenance and air flow
- ② Clearance recommended for coil removal
- Water inlet
- Water outlet
- Air outlet, do not obstruct
- Electrical cabinet

Notes:
Non-contractual drawings.

When designing a system, refer to the certified dimensional drawings provided with the unit or available on request.

Please refer to the certified dimensional drawings for the positioning of the fixing points, weight distribution points and centre of gravity coordinates.

DIMENSIONS

AQUACIAT^{POWER} LD ST-HE 1600C to 2000C without buffer tank

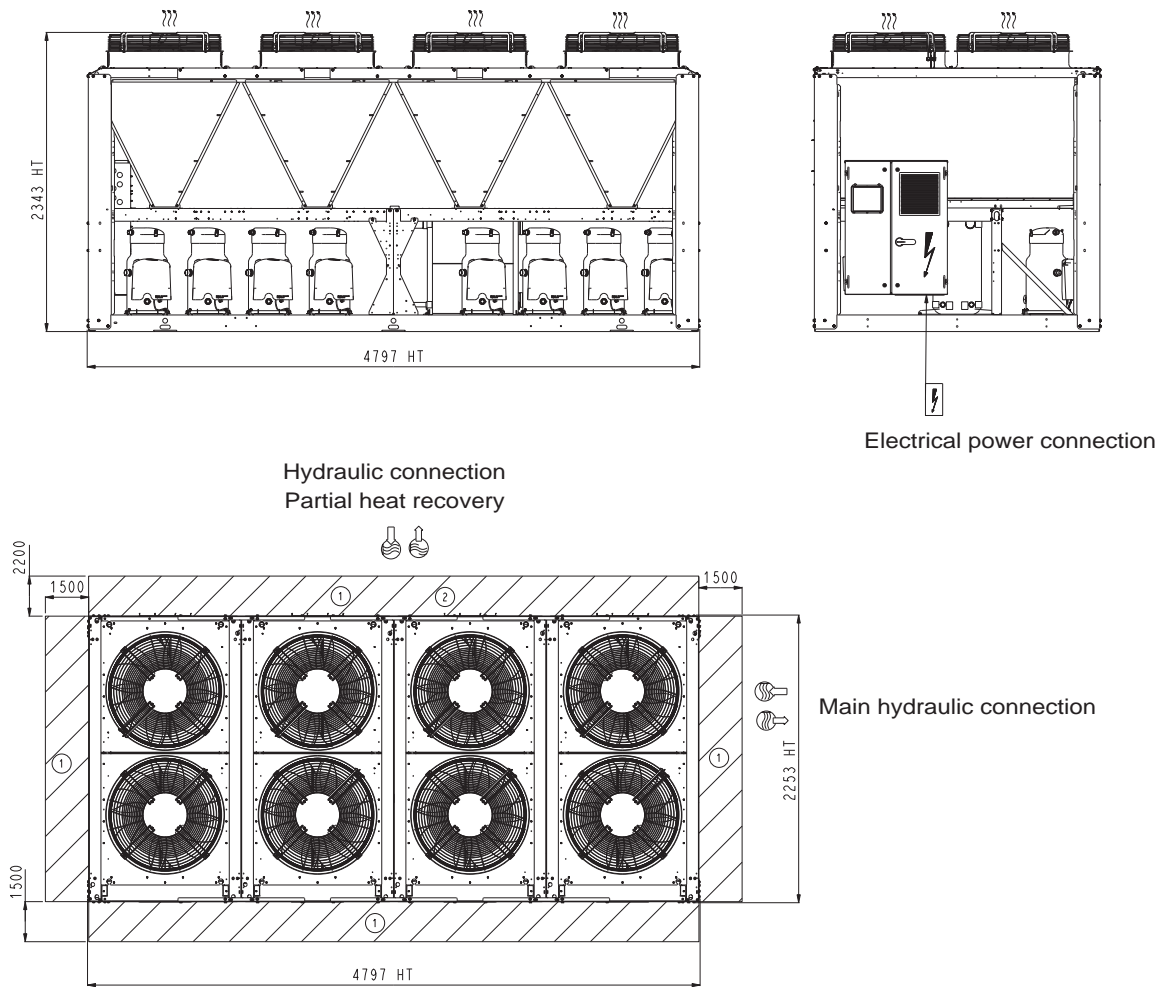

Key
All dimensions in mm

- ① Clearance required for maintenance and air flow
- ② Clearance recommended for coil removal
- Water inlet
- Water outlet
- Air outlet, do not obstruct
- Electrical cabinet

Notes:
Non-contractual drawings.

When designing a system, refer to the certified dimensional drawings provided with the unit or available on request.

Please refer to the certified dimensional drawings for the positioning of the fixing points, weight distribution points and centre of gravity coordinates.

DIMENSIONS

AQUACIAT^{POWER} LD ST-HE 1600C to 2000C with buffer tank

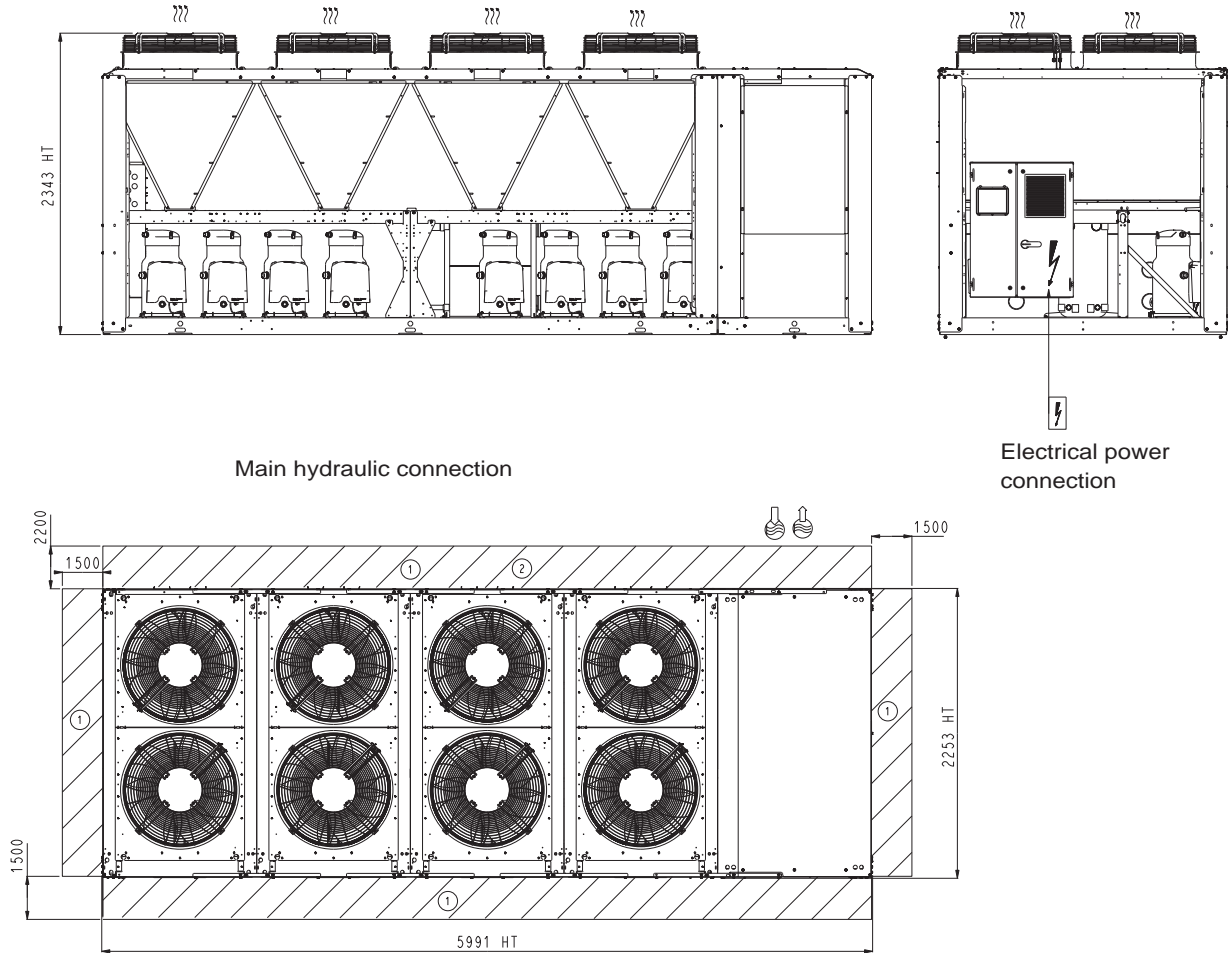

Key
All dimensions in mm

- ① Clearance required for maintenance and air flow
- ② Clearance recommended for coil removal
- Water inlet
- Water outlet
- Air outlet, do not obstruct
- Electrical cabinet

Notes:
Non-contractual drawings.

When designing a system, refer to the certified dimensional drawings provided with the unit or available on request.

Please refer to the certified dimensional drawings for the positioning of the fixing points, weight distribution points and centre of gravity coordinates.

INSTALLATION RECOMMENDATIONS

■ Water quality criteria to be respected

Warning: It is essential that an 800-micron water filter be placed on the unit's water inlet during installation. The quality of the water used has a direct impact on the correct and compliant operation of the machine and its service life. This is particularly true if the water used clogs or corrodes components or promotes the growth of algae or micro-organisms. The water must be tested to determine whether it is suitable for the unit. It is also tested to determine whether chemical treatment is necessary and will suffice to make it of acceptable quality. This analysis should confirm whether or not the various machine components are compatible with the water they come into contact with on-site.

Warning: failure to follow these instructions will result in the immediate voiding of the unit's warranty.

■ Lifting and handling

The utmost safety precautions must be taken when lifting and handling the unit.

Always follow the lifting diagram on the unit and in the instruction manual.

Before attempting to lift the unit, make sure the path leading to its intended location is free from obstacles. Always keep the unit vertical when moving it. Never tip it or lie it on its side.

■ Choosing a location for the unit

AQUACIAT^{POWER} units are designed for outdoor installation. Precautions should be taken to protect them from freezing temperatures. Special attention should be paid to ensure sufficient free space (including at the top) to allow maintenance. The unit must be placed on a perfectly level, fireproof surface strong enough to support it when ready for operation. Noise pollution from auxiliary equipment such as pumps should be studied thoroughly.

Potential noise transmission routes should be studied, with assistance from an acoustical engineer if necessary, before installing the unit. It is strongly recommended that flexible couplings are placed over pipes and anti-vibration mounts are fitted underneath the unit (equipment available as an option) to reduce vibrations, and the noise this causes, as much as possible.

■ Fitting accessories supplied separately

A number of optional accessories may be delivered separately and installed on the unit on site.

You must follow the instructions in the manual.

■ Electrical connections

You must follow the instructions in the manual. All information concerning electrical connections is stated on the wiring diagrams provided with the unit. Always follow this information to the letter.

Electrical connections must be made in accordance with best current practices and applicable standards and regulations.

Electrical cable connections to be made on-site:

- Electrical power supply to unit
- Contacts available as standard enabling the machine to be controlled remotely (optional)

It should be noted that the unit's electrical system is not protected against lightning strikes.

Therefore devices to protect against transient voltage surges must be installed on the system and inside the power supply unit.

■ Pipe connections

You must follow the instructions in the manual. All pipes must be correctly aligned and slope toward the system's drain valve. Pipes must be installed to allow sufficient access to the panels and fitted with heat insulation.

Pipe mountings and clamps must be separate to avoid vibrations and pressure on the unit. Water flow shut-off and control valves must be fitted when the unit is installed.

Pipe connections to be made on-site:

- water supply with pressure-reducing valve
 - evaporator, condenser and drain
- The following are a few examples of accessories essential to any hydraulic circuit, which must also be installed:
- water expansion vessel
 - drain nozzles at pipe low points
 - exchanger shut-off valves equipped with filters
 - air vents at pipe high points
 - check the system's water capacity (install a buffer water tank if necessary)
 - flexible couplings on exchanger inlets and outlets

■ Warning:

- Pressure in the water circuits below 4 bar for units equipped with the hydraulic module
- Place the expansion vessel upstream of the pump.
- Do not place any valves on the expansion vessel.
- Make sure the water circulation pumps are placed directly at the exchanger inlets.
- Make sure the pressure of the water drawn in by the circulation pumps is greater than or equal to the required minimum pressure (NPSH), particularly if the water circuits are "open".
- Test the water quality in accordance with the relevant technical specifications.
- Take the necessary precautions to protect the unit and hydraulic system from freezing temperatures (e.g. allow for the possibility of draining the unit). If glycol is added to prevent freezing, check its type and concentration before system start-up.
- Before making any final hydraulic connections, flush the pipes with clean water to remove any debris in the network.

■ System start-up

CIAT or a CIAT-approved firm must perform system start-up on the units.

You must follow the instructions in the manual.

List of system start-up checks (non-exhaustive):

- Correct positioning of unit
- Power supply protections
- Phases and direction of rotation
- Wiring connections on unit
- Direction of water flow in unit
- Cleanliness of water circuit
- Water flow rate at specified value
- Pressure in the refrigerating circuit
- Direction of rotation of compressors
- Water pressure drops and flow rates
- Operating readings

■ Maintenance operations

Specific preventive maintenance operations are required at regular intervals and should be performed by CIAT-approved contractors.

The operating parameters are read and noted on a "CHECK LIST" form to be returned to CIAT.

To do this, you must refer to and comply with the instruction manual.

You must take out a maintenance contract with a CIAT-approved refrigeration equipment specialist. Such a contract is required even during the warranty period.

CONTROL

USER-FRIENDLY INTERFACE CONSOLE

- User-friendly 5 inch touch screen.
- Information displayed in a choice of languages.
- Temperature and pressure readings.
- Operating and fault status diagnostics.
- Master/slave control of two machines in parallel.
- Fault memory management.
- Pump management.
- Time schedule.
- IP web server
- Programmable maintenance
- Preventive maintenance
- F-GAS maintenance
- E-mail alert



REMOTE M2M MACHINE SUPERVISION

Two years of Full Serenity with:

- Monitoring of machine operation (operation overviews and curves, alarm logs).
- E-mail alerts for alarms (optional SMS alerts).
- Remote update of the M2M.
- Access to a log of machine operation data.
- Remote advice for using M2M.
- System start-up and operating readings.

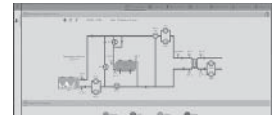

PRODUCT FUNCTIONALITY

POTENTIAL-FREE (DRY) CONTACTS AVAILABLE AS STANDARD

- Inputs:**
- Automatic operation control
 - Selection of setpoints 1 / 2
 - Power limitation.

- Outputs:**
- General fault reporting
 - Operational status reporting

Additional inputs available as options:

- Setpoint adjustable by 4-20 mA signal
- Power limitation adjustable by 4-20 mA signal
- Second power limitation level
- End of storage signal
- User fault reporting
- Time schedule override

Additional outputs available as options:

- Indication of the power level by 0-10 V signal
- Minor alert reporting
- Unit shut down general fault reporting
- Desuperheater pump On/Off control

CMS CONNECTIONS

- MODBUS-JBUS RTU (RS485) or TC/IP (standard) open protocol
- LONWORKS protocol (option)
- BACNET IP protocol (option)

Customer CMS COMMUNICATION

Via potential-free (dry) contact

Via BUS communication

CIAT SYSTEM FUNCTIONALITY

Communication with Hysys system (generator, transmitter, air handling unit), controlled by an Easy CIATcontrol or Smart CIATcontrol touch tablet.

- **Logging** of consumption data and temperatures
- **Optimal Water[®]**: optimisation of producer performance based on building requirements
- **Optimal Stop and Start**: optimisation of the building restart time



Communication with CIAT Energy pool controlled by Power'Control.

Integrated Power'Control:

- Energy optimisation of refrigeration and heating using several generators,
- Manages free cooling capacity
- Uses heat recovery to supply domestic hot water.



This document is not legally binding. As part of its continuous drive to improve its equipment, CIAT reserves the right to make any technical modifications without prior notice.

Head office

700 Avenue Jean Falconnier - B.P. 14
01350 - Culoz - France
Tel.: +33 (0)4 79 42 42 42
Fax: +33 (0)4 79 42 42 10
info@ciat.fr - www.ciat.com



CIAT Service

Technical support: 0 892 05 93 93 (€0.34/min)
Spare parts: 0 826 96 95 94 (€0.15/min)
PDRFrance@ciat.fr - PDRGarantie@ciat.fr

