

# SCHEMA ELECTRIQUE ELECTRICAL DIAGRAM

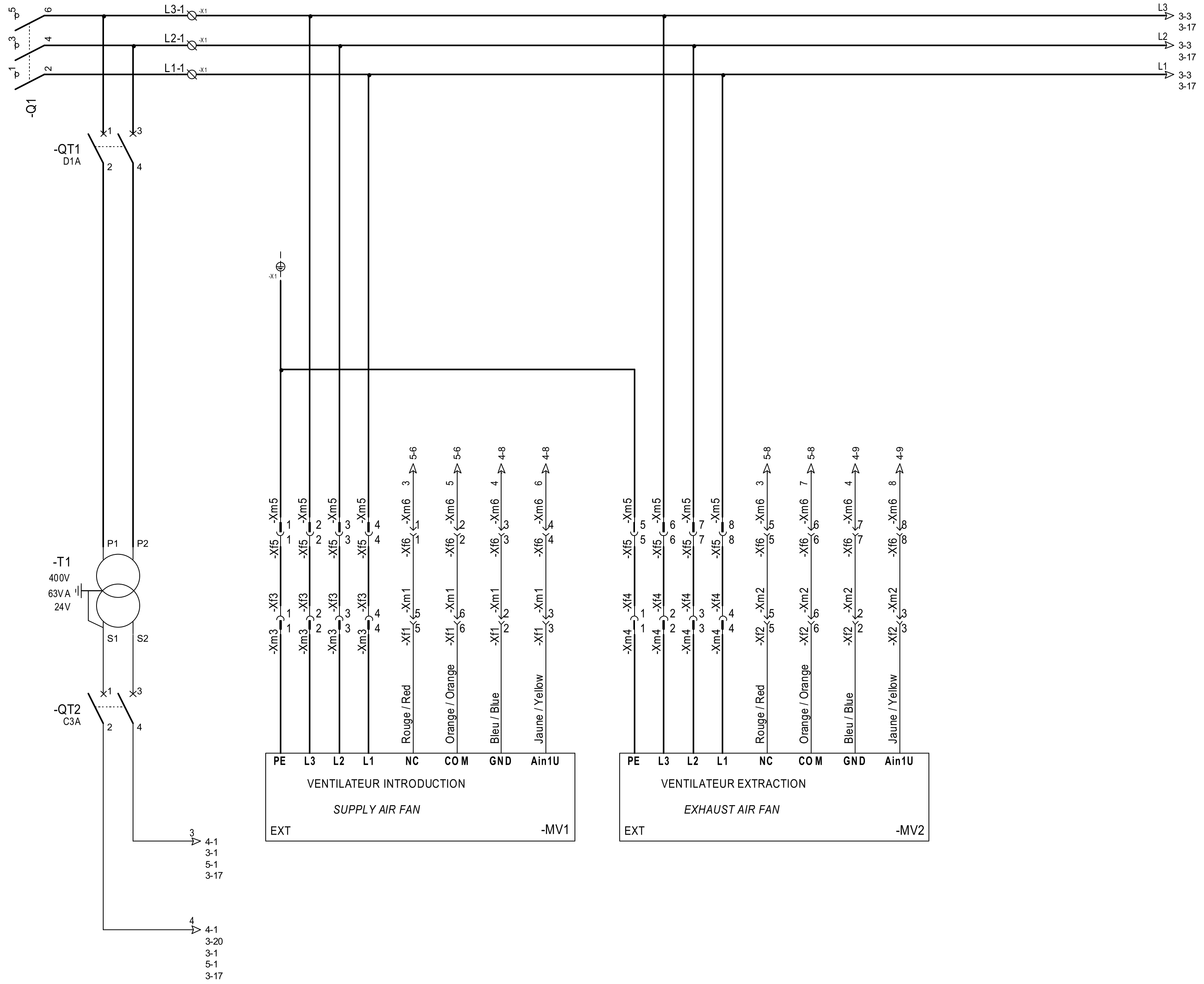

				NUMERO DE COMMANDE : ORDER NUMBER :
				CLIENT : CUSTOMER :
				APPAREIL OU UNITE : TYPE OF UNIT : CLASSIC PHE 2000 A 6000
				TENSION : SUPPLY : 3~ 400V 50Hz
				REFERENCE : REFERENCE :
				DESIGNATION : DESIGNATION :
NSC-AGP	31/07/2019	01	Modification couleurs fils Y1 et Y2	
BB-AGP	27/09/2018	00	Capture	
DESS	DATE	IND	MODIFICATION	
N° OMT : 47233		CREATEUR : CREATED BY : BB-AGP		LEGENDE : LEGEND :
		DATE : 27/09/2018 DATE :		NUMERO DE SCHEMA DIAGRAM NUMBER 7561780
				INDICE INDEX 01
				FOLIO FOLIO 1/10

ALIMENTATION 3 ~ 400V 50Hz  
 RACCORDEMENT SUR  
 LE SECTIONNEUR  
 SUPPLY 3 ~ 400V 50Hz  
 CONNECTION ON  
 ISOLATOR



ARM

DESIGNATION :  
 DESIGNATION :



PUISSANCE  
 POWER

NUMERO DE SCHEMA DIAGRAM NUMBER	INDICE INDEX	FOLIO FOLIO
7561780	01	2/10

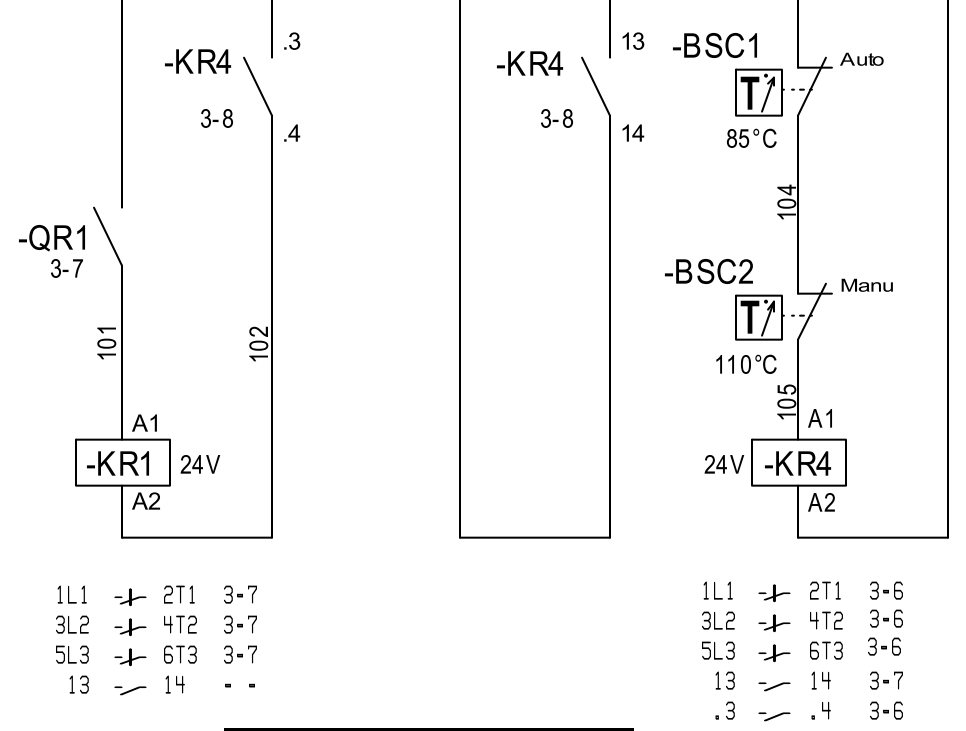
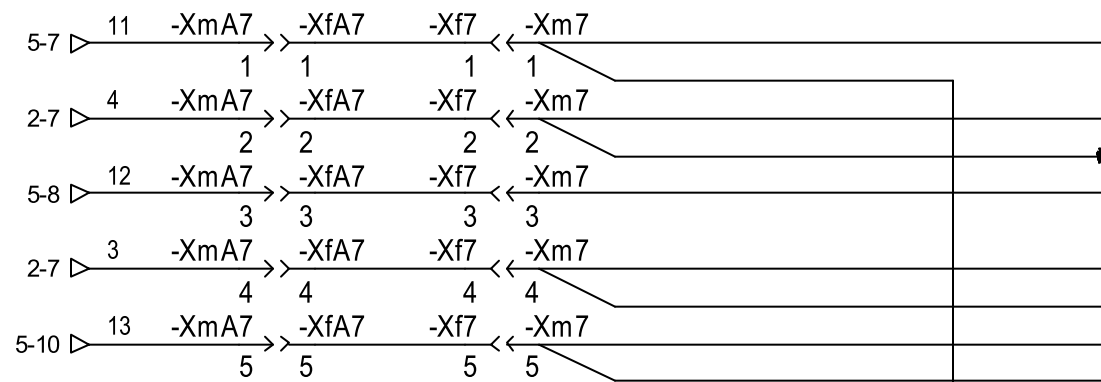
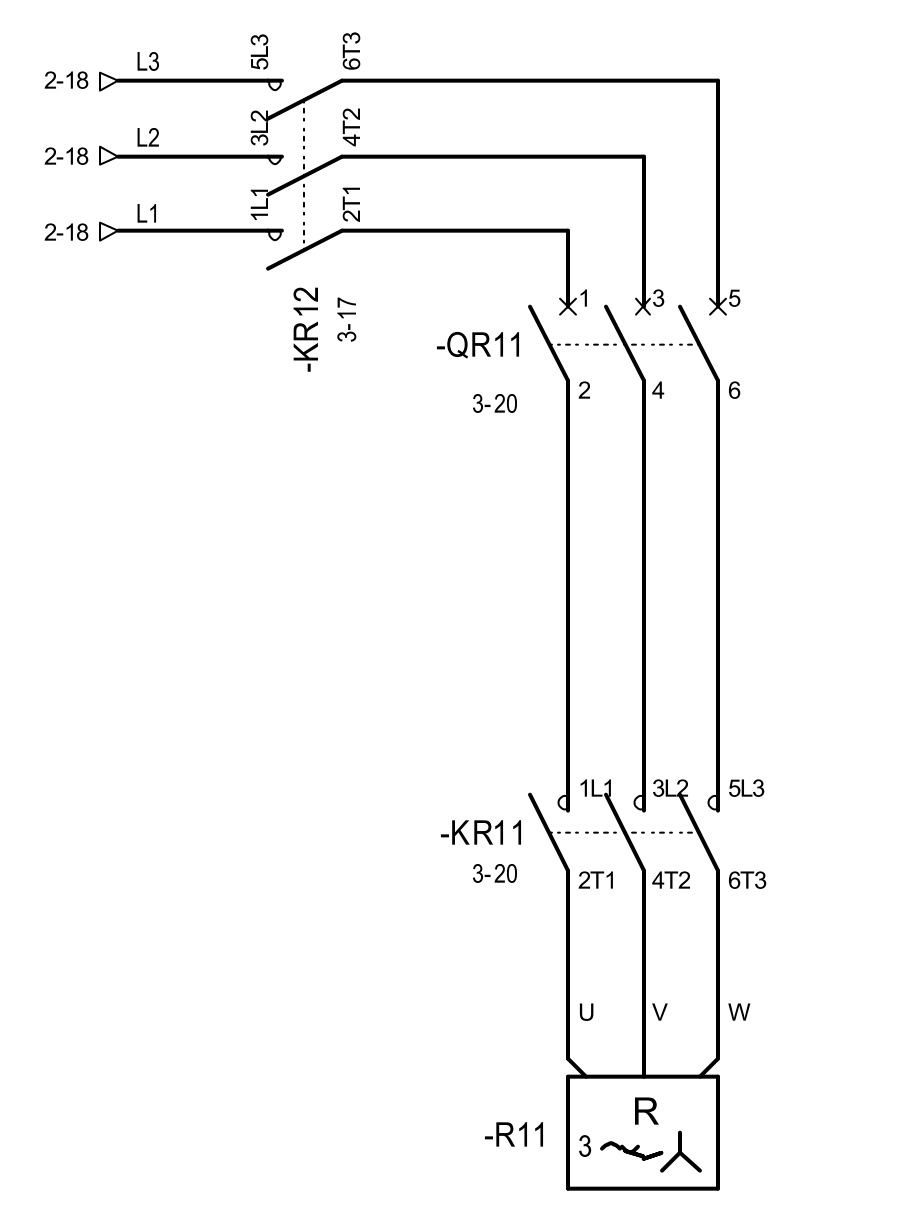
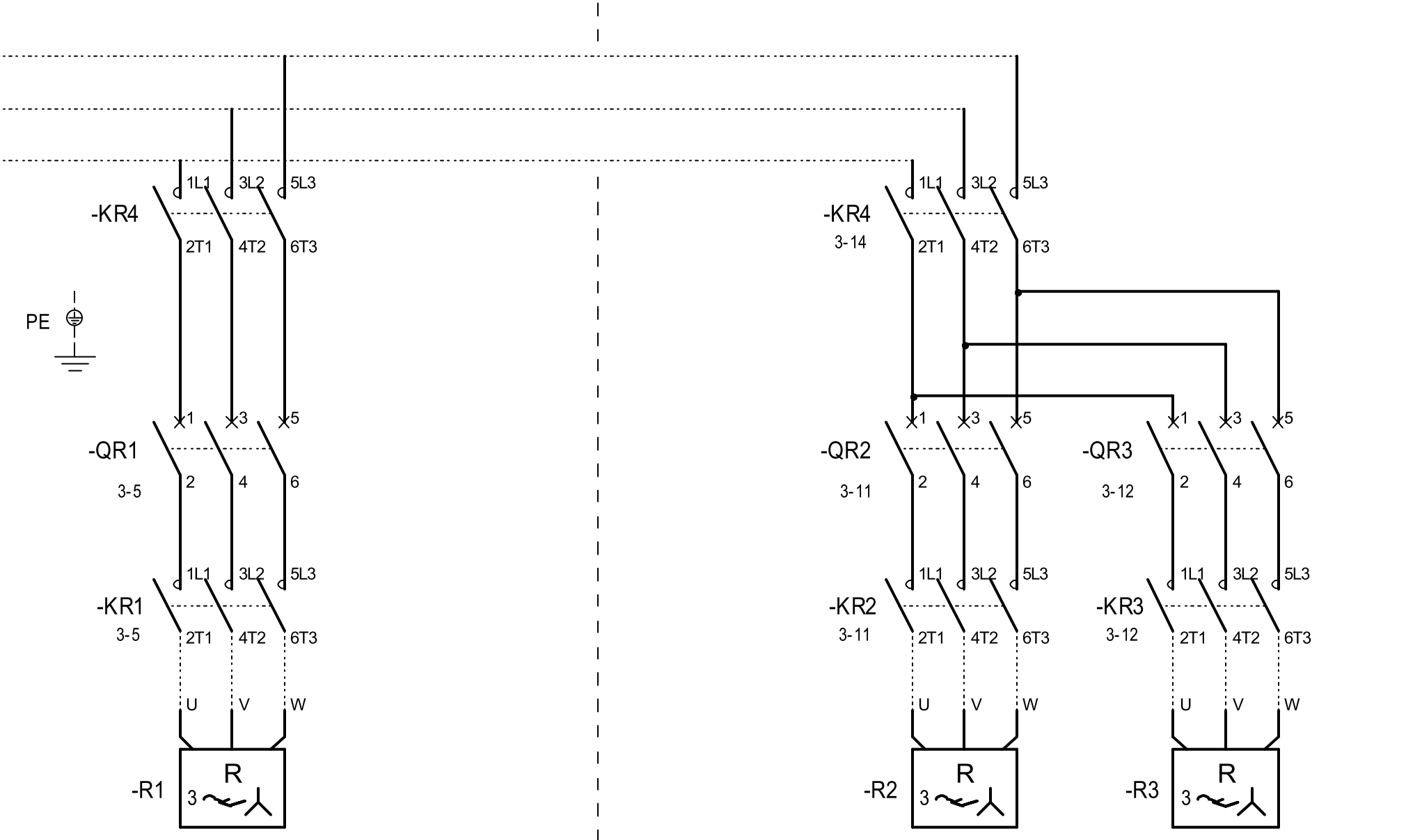
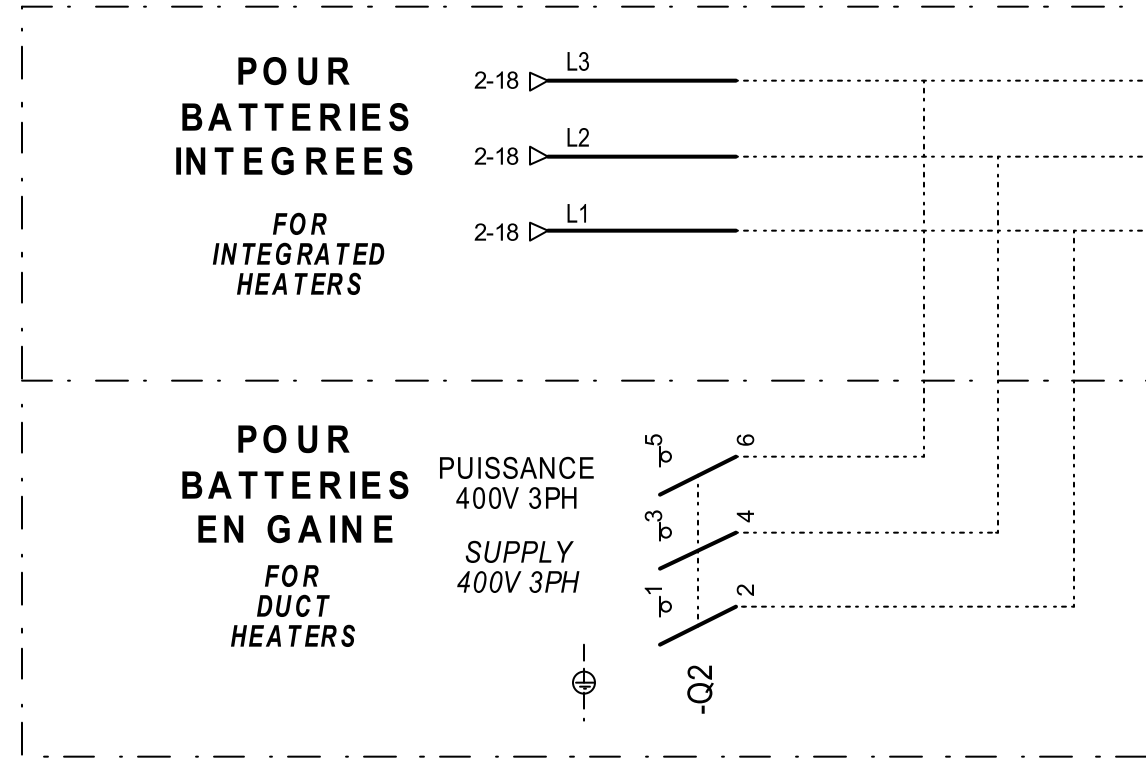

**Batterie 1 étage**  
**Step 1 electric heater**

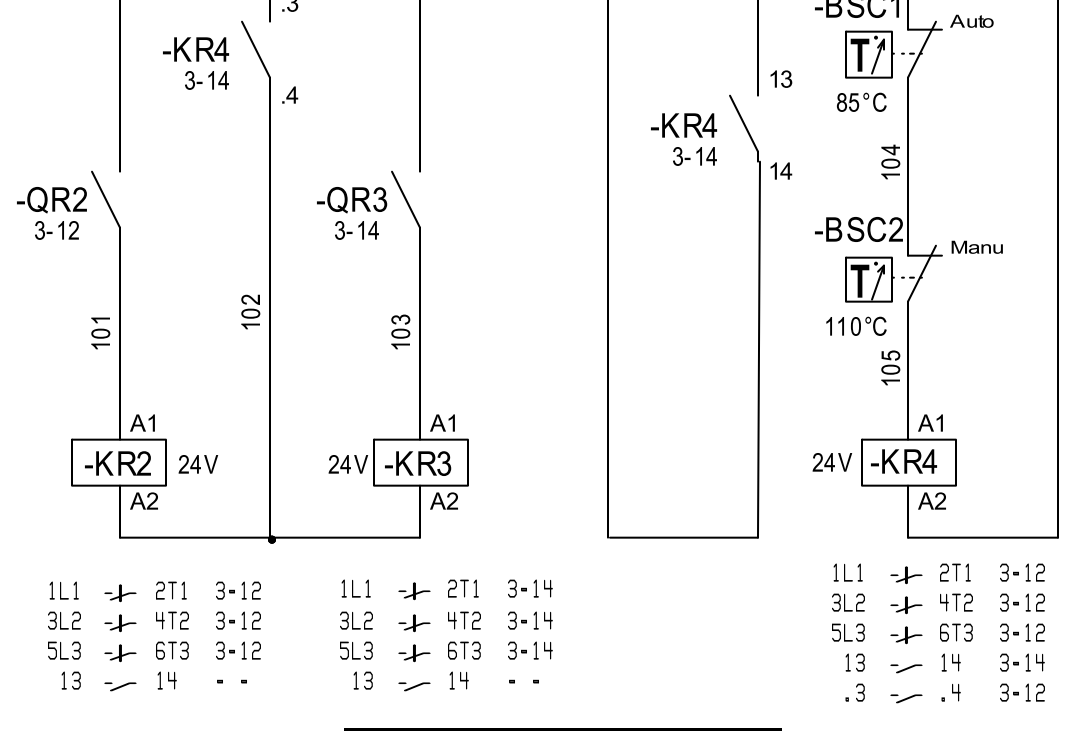

**Batterie 2 étages**  
**Step 2 electric heater**

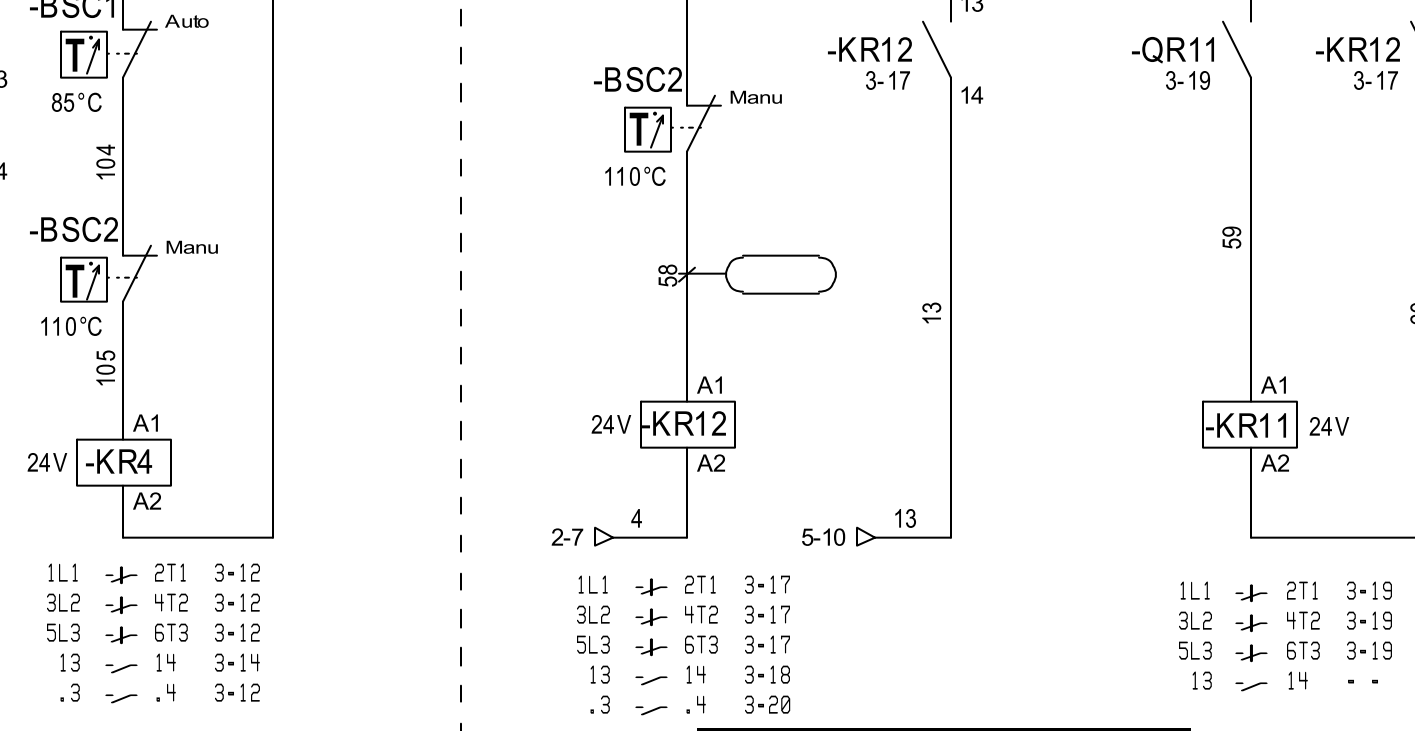

**Batterie Prechauffe**  
**Pre-heater**

DESIGNATION :  
DESIGNATION :



**BATTERIES ELECTRIQUES**  
**ELECTRIC HEATER**

NUMERO DE SCHEMA  
DIAGRAM NUMBER  
**7561780**

INDICE  
INDEX  
**01**

FOLIO  
FOLIO  
**3/10**

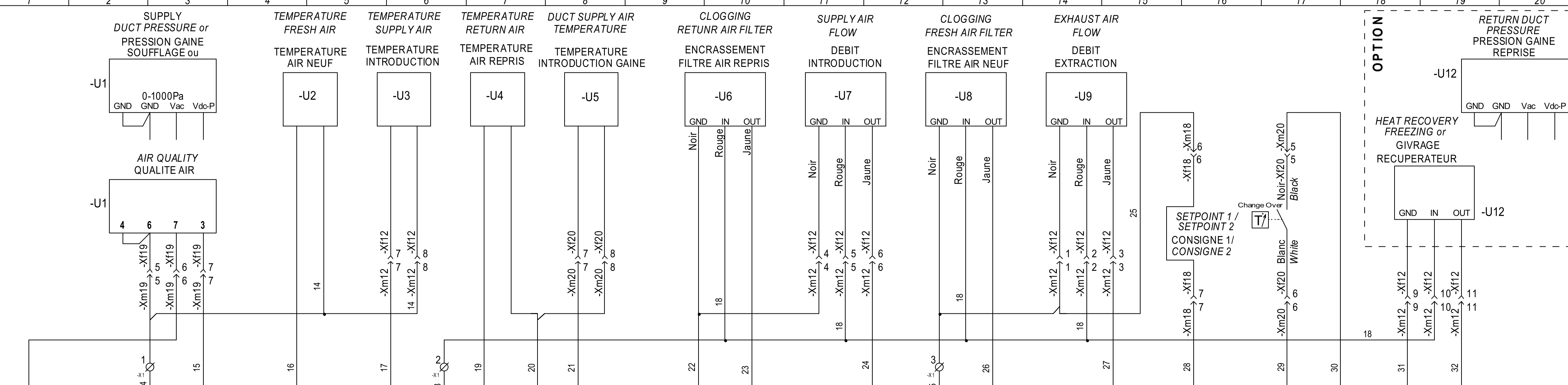

# AUTOMATE

## CONTROLLER

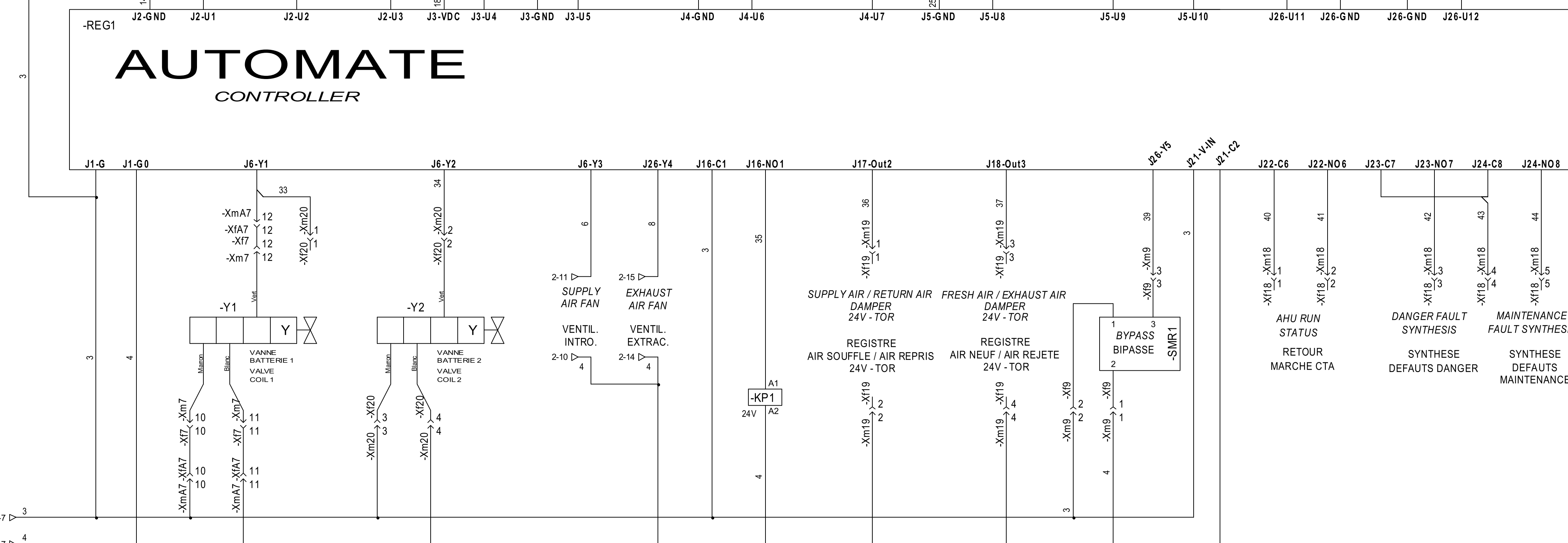

PUMP 1 CONTROL  
COMMANDE POMPE 1

14 12 11 5-16  
24 22 21 . .

ARM

DESIGNATION :  
DESIGNATION :



COMMANDE  
CONTROL

NUMERO DE SCHEMA  
DIAGRAM NUMBER  
**7561780**

INDICE  
INDEX  
**01**

FOLIO  
FOLIO  
**4/10**

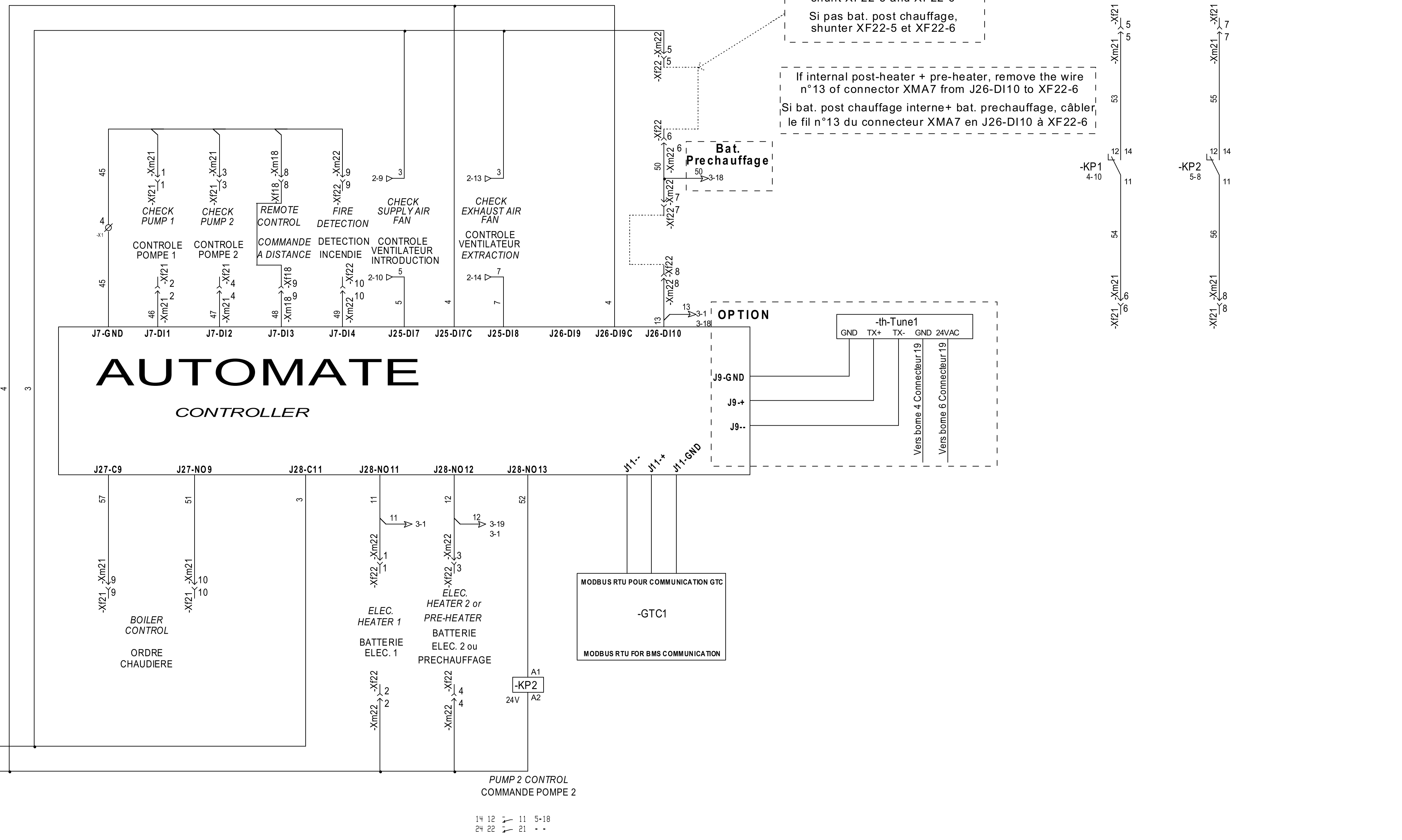

ARM

DESIGNATION :  
DESIGNATION :



COMMANDE -2  
CONTROL -2

NUMERO DE SCHEMA  
DIAGRAM NUMBER  
**7561780**

INDICE  
INDEX  
**01**

FOLIO  
FOLIO  
**5/10**

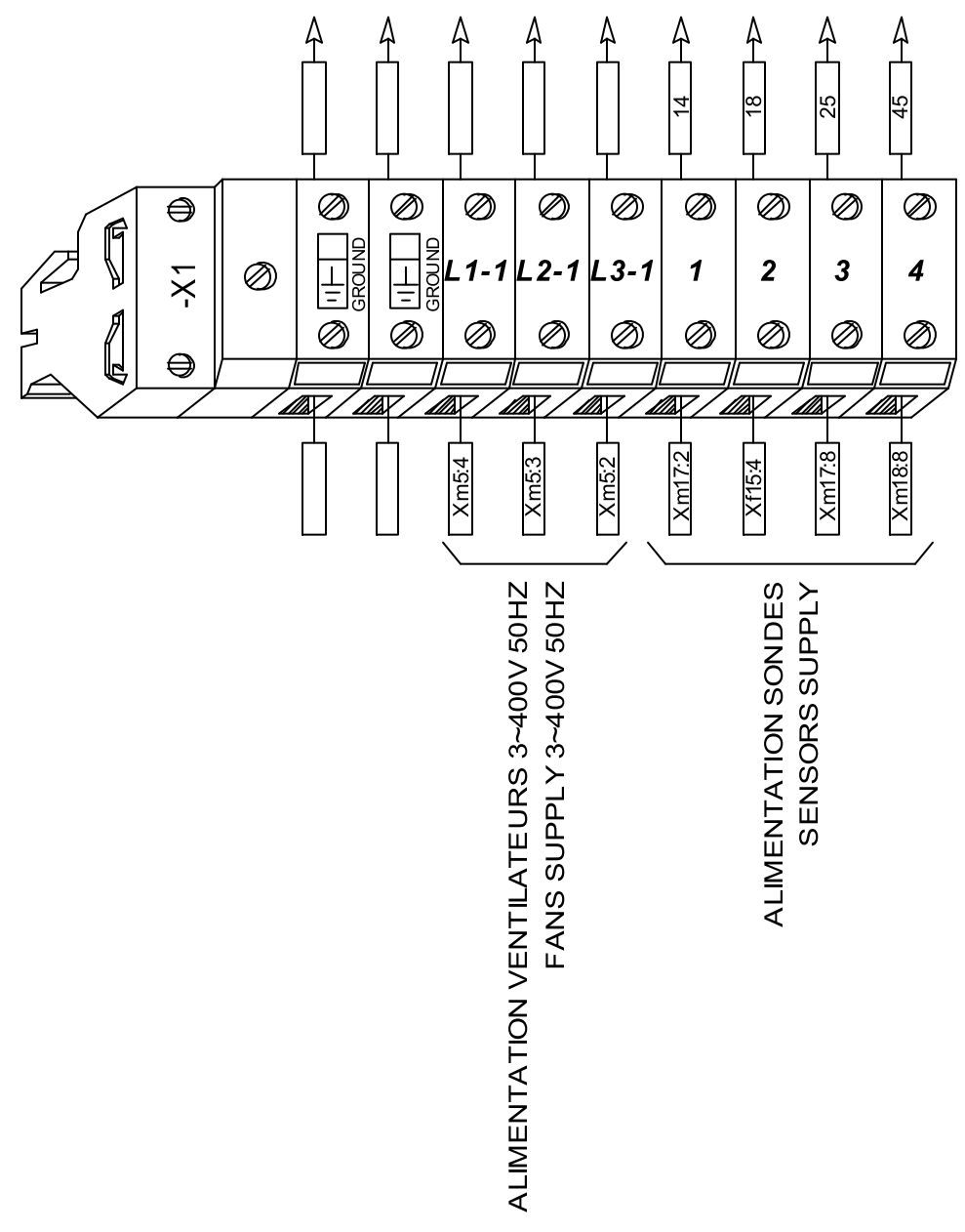

ARM

DESIGNATION :  
DESIGNATION :

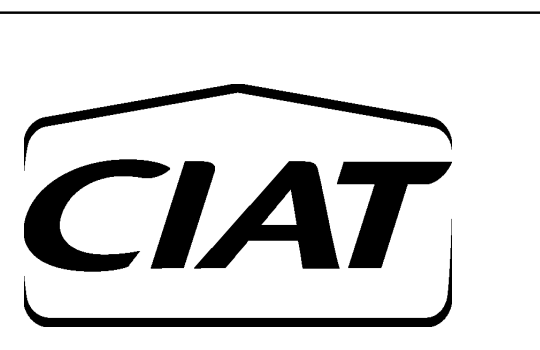

Bornier : X1  
Terminal : X1

NUMERO DE SCHEMA DIAGRAM NUMBER	INDICE INDEX	FOLIO FOLIO
7561780	01	6/10

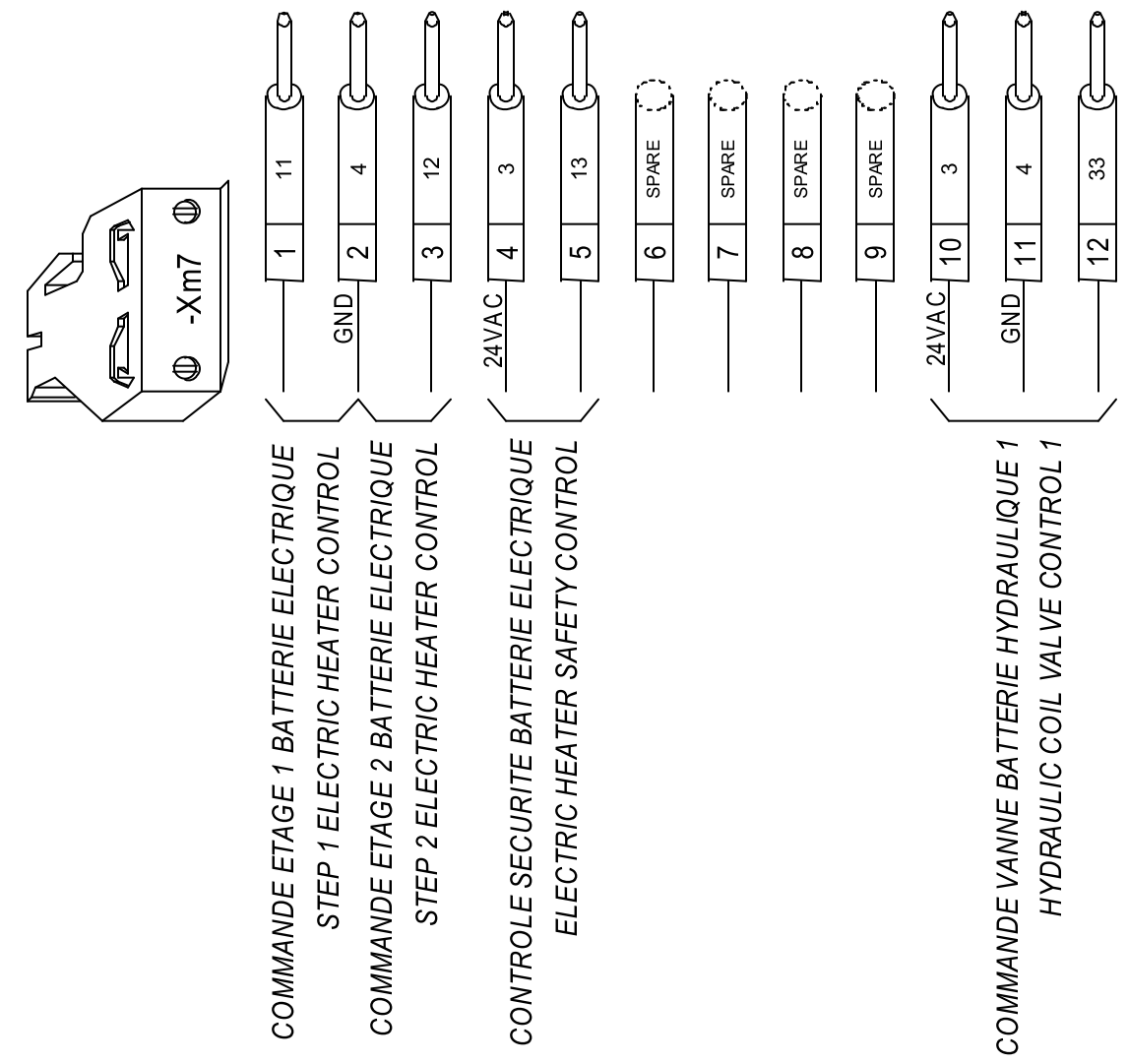
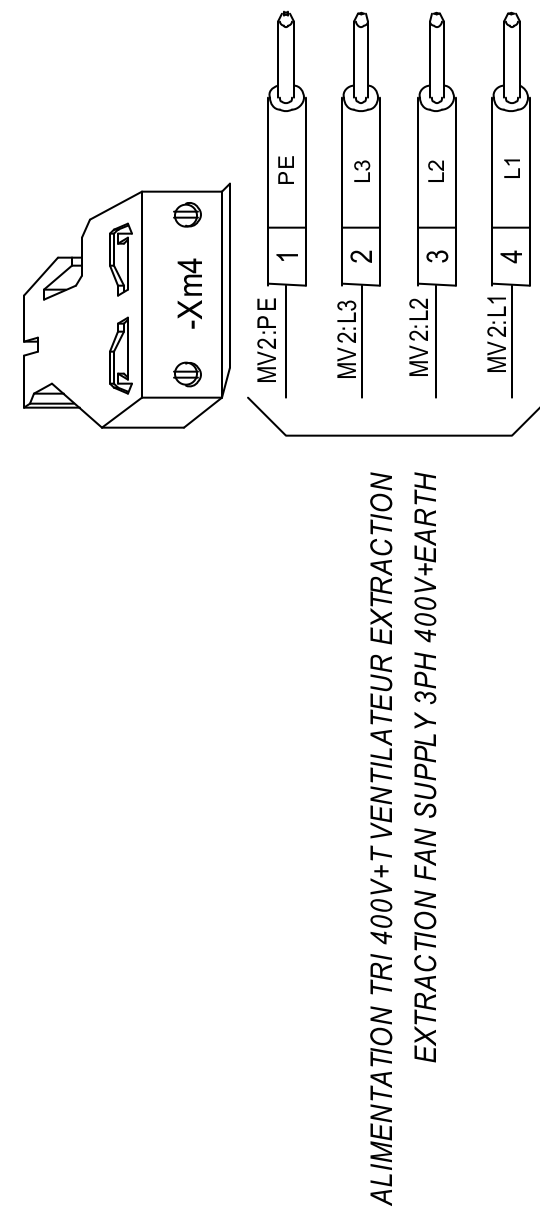
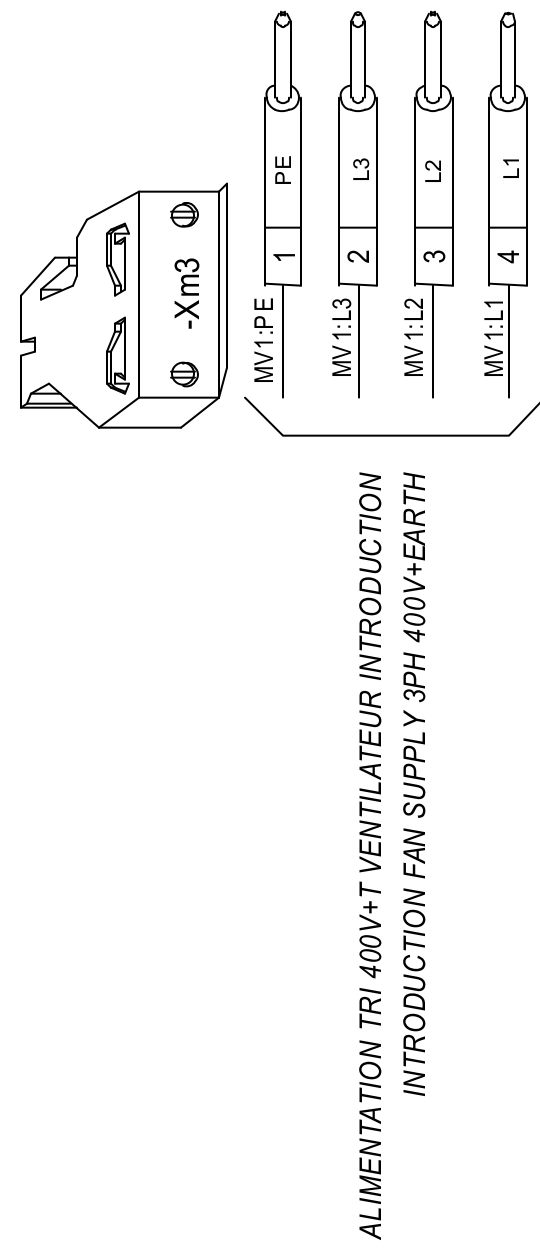
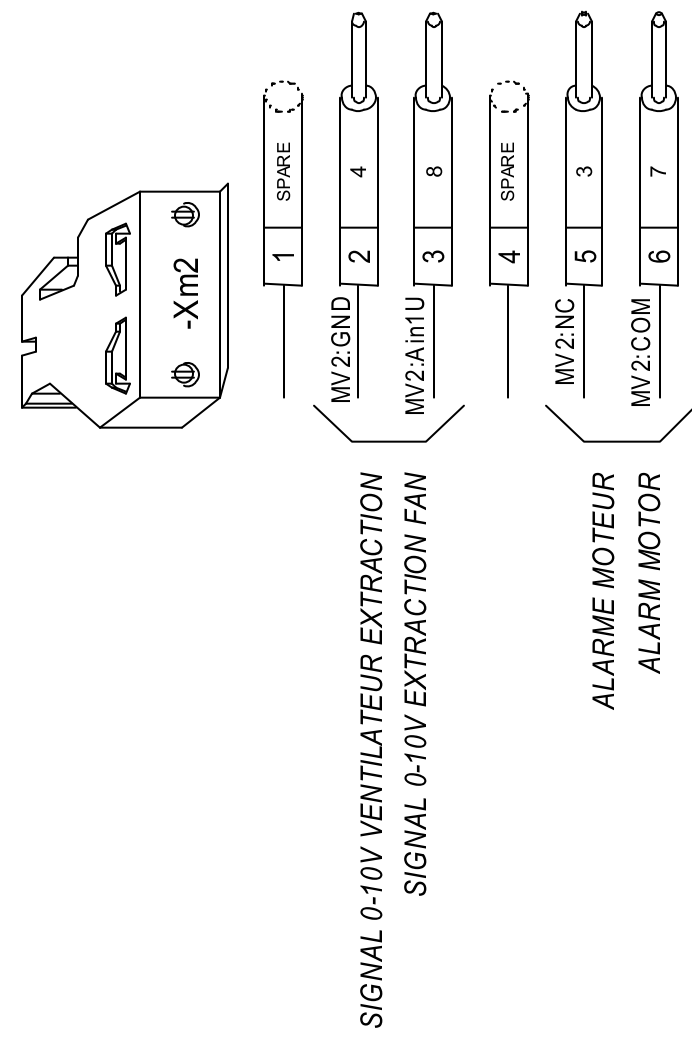
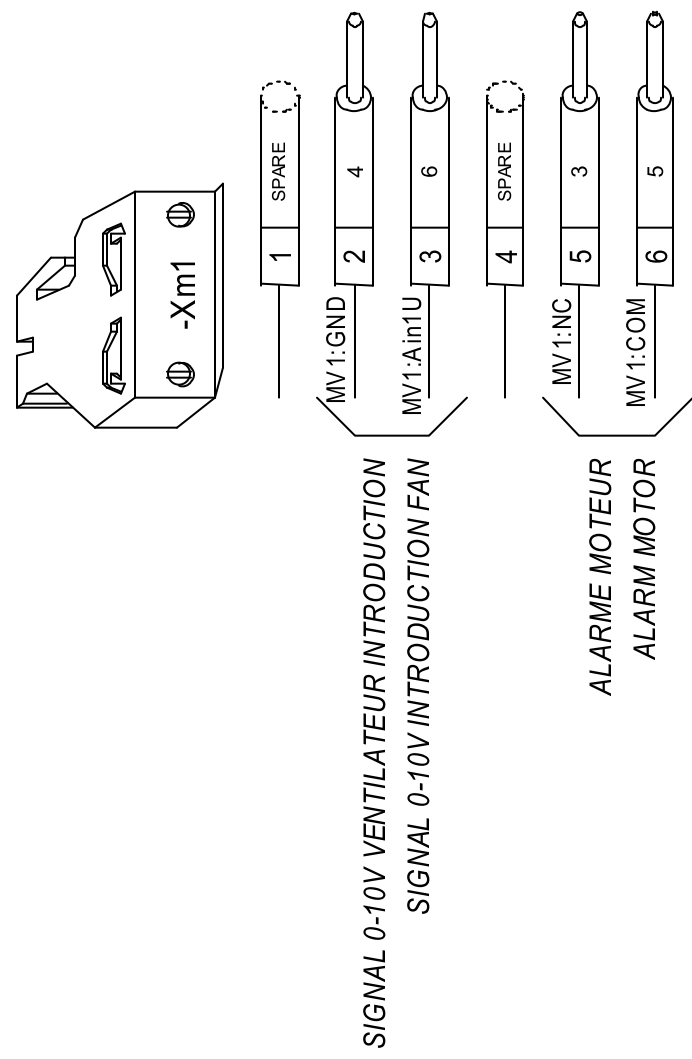

ARM

DESIGNATION :  
DESIGNATION :



Connecteurs: Xm1, 2, 3, 4 et 7  
Connectors: Xm1, 2, 3, 4 and 7

NUMERO DE SCHEMA  
DIAGRAM NUMBER  
7561780

INDICE  
INDEX  
01

FOLIO  
FOLIO  
7/10

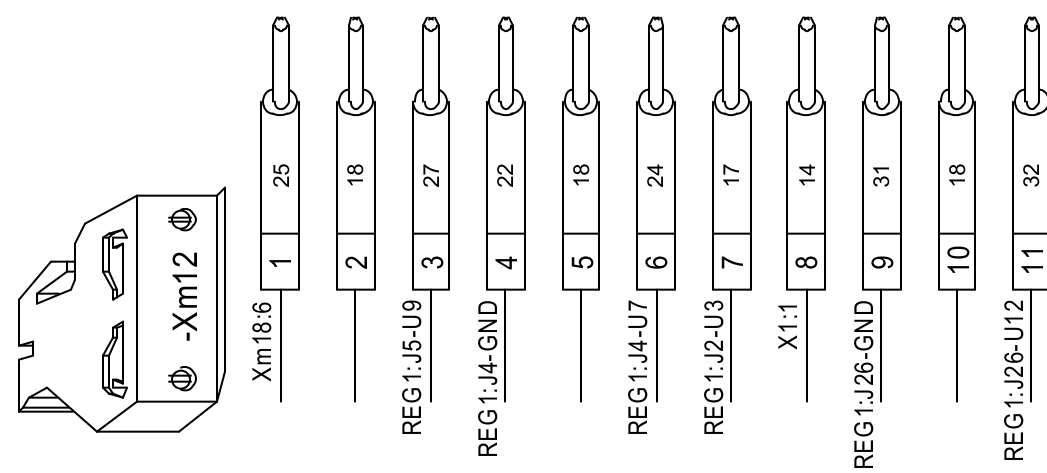
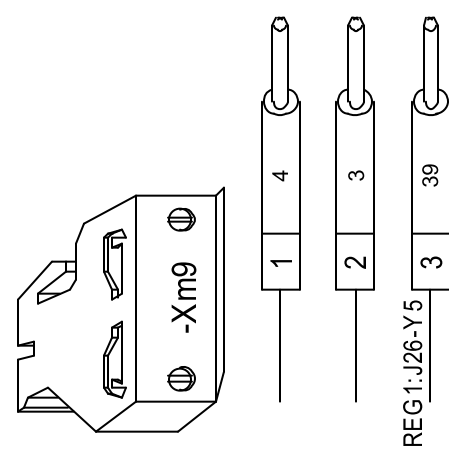
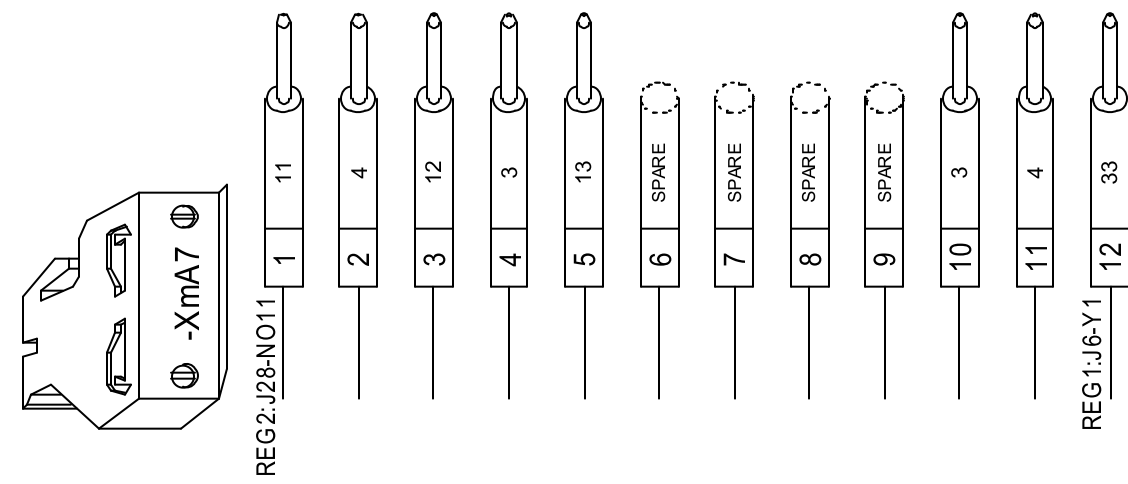
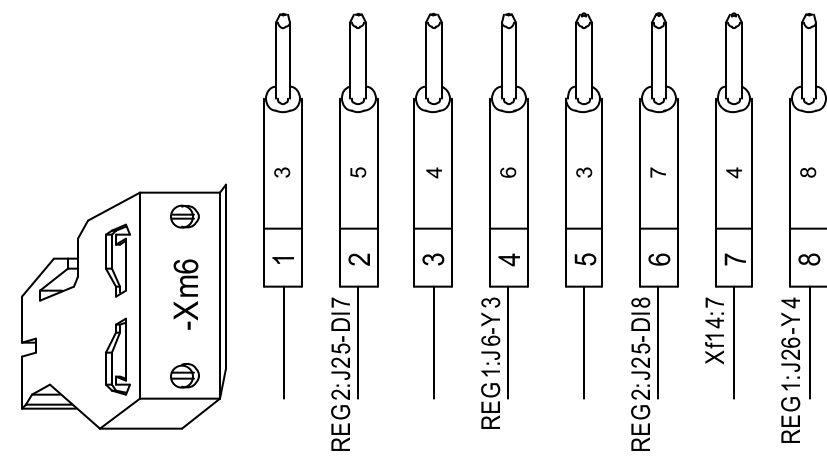
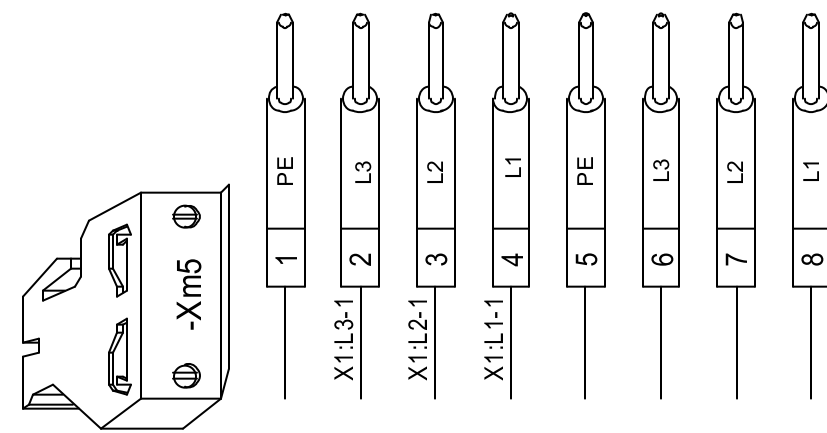

ARM

DESIGNATION :  
DESIGNATION :



Connecteurs: Xm5, 6, A7, 9 et 12

Connectors: Xm5, 6, A7, 9 and 12

NUMERO DE SCHEMA  
DIAGRAM NUMBER

7561780

INDICE  
INDEX

01

FOLIO  
FOLIO

8/10



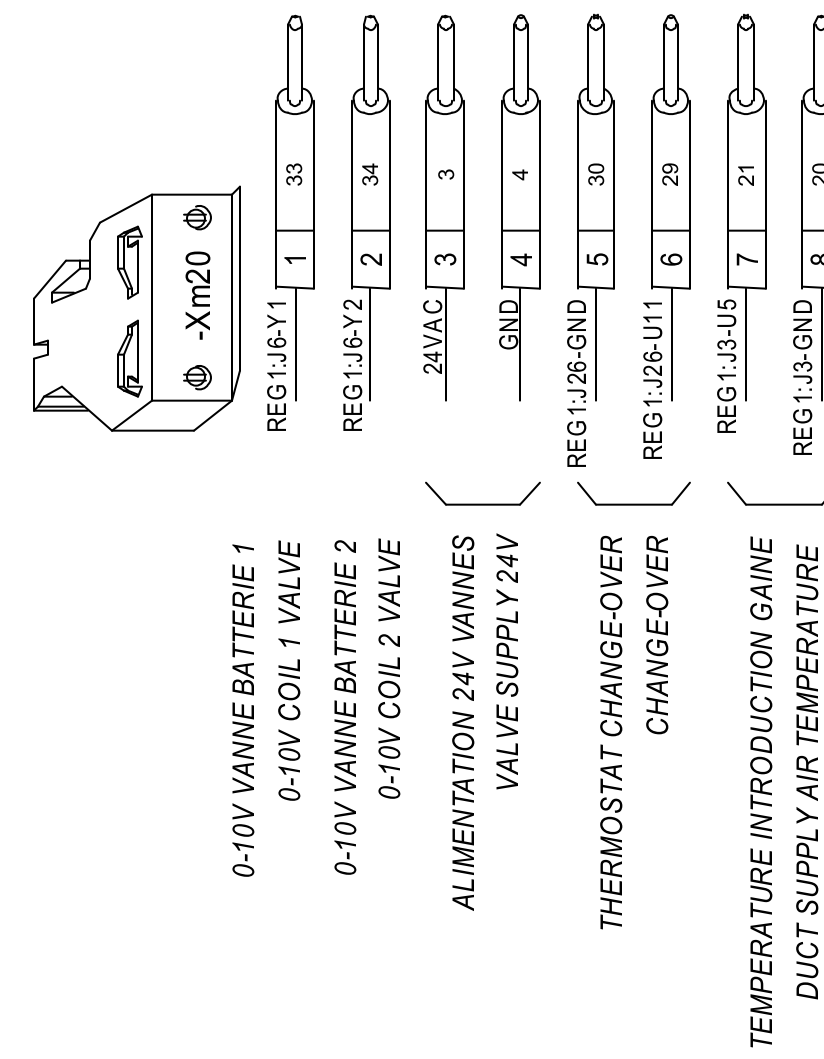
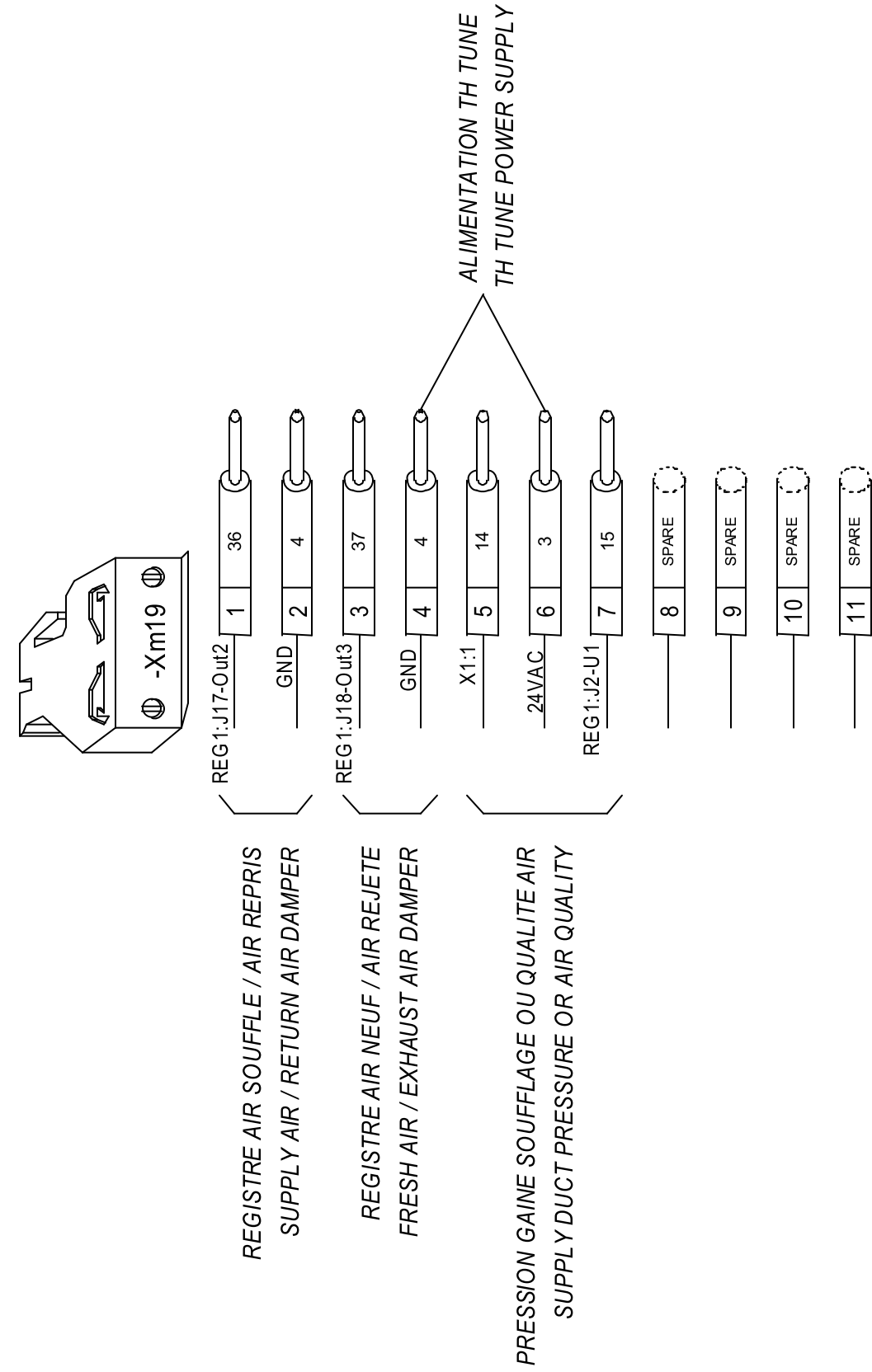
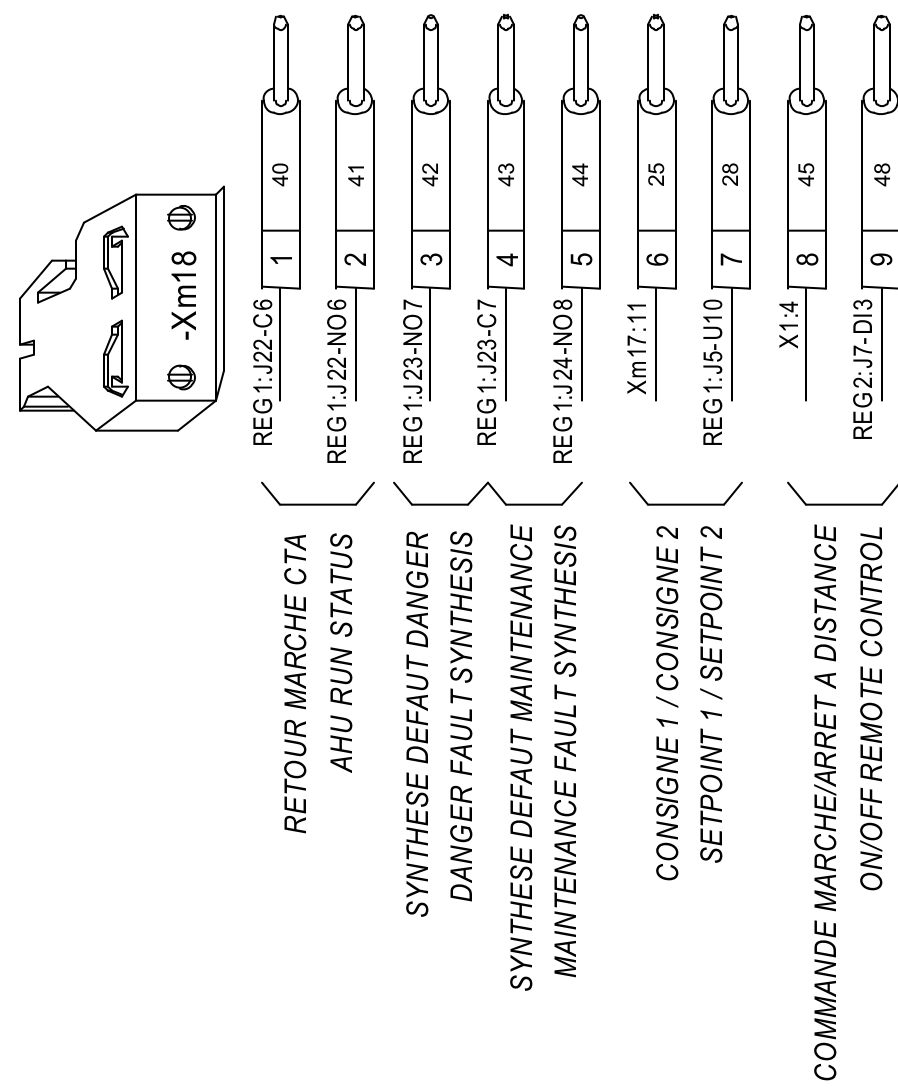

ARM

DESIGNATION :  
DESIGNATION :



Connecteurs: Xm18, 19 et 20 (OPTIONS CLIENT)  
Connectors: Xm18, 19 et 20 (CUSTOMER OPTIONS)

NUMERO DE SCHEMA  
DIAGRAM NUMBER  
7561780

INDICE  
INDEX  
01

FOLIO  
FOLIO  
9/10

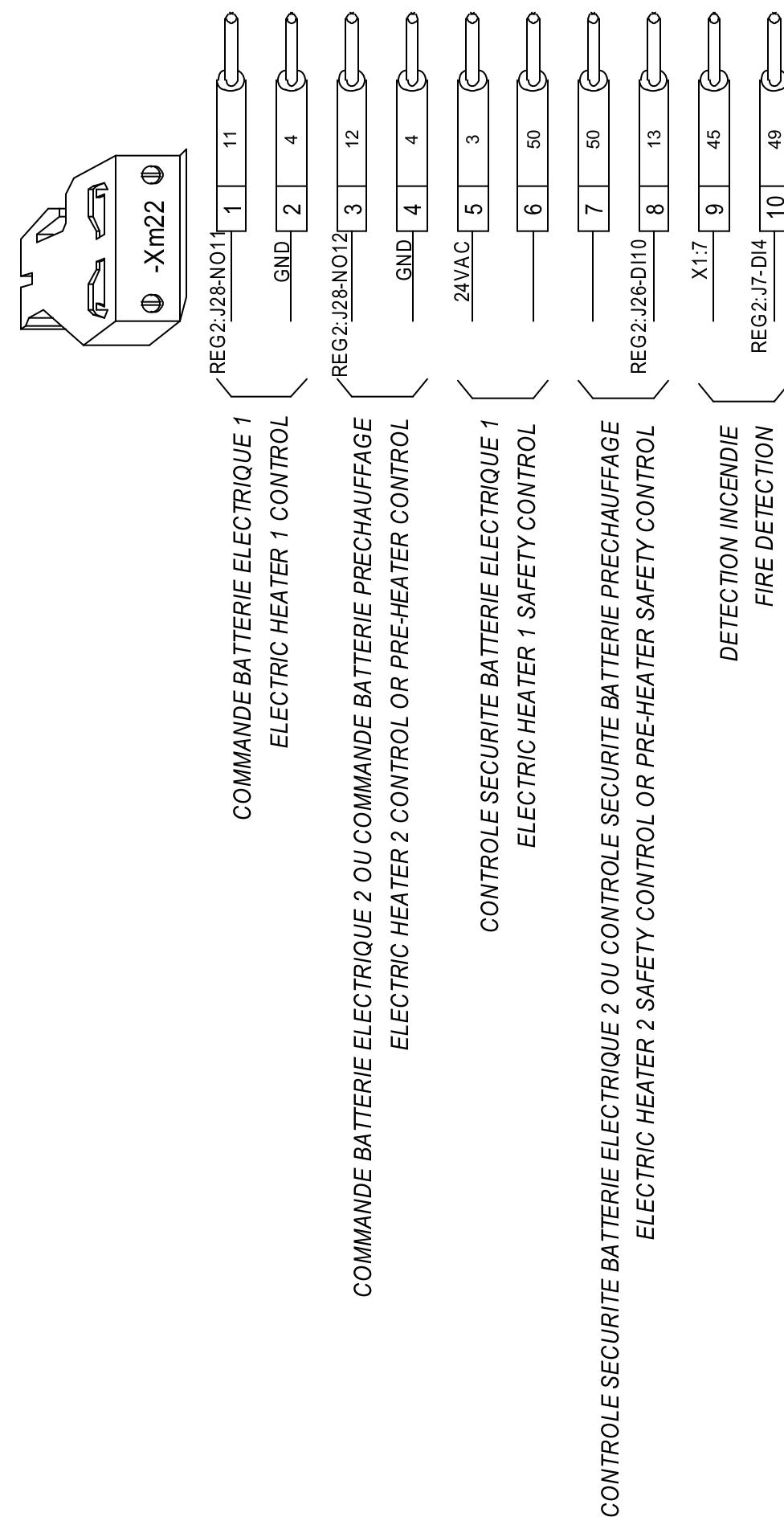
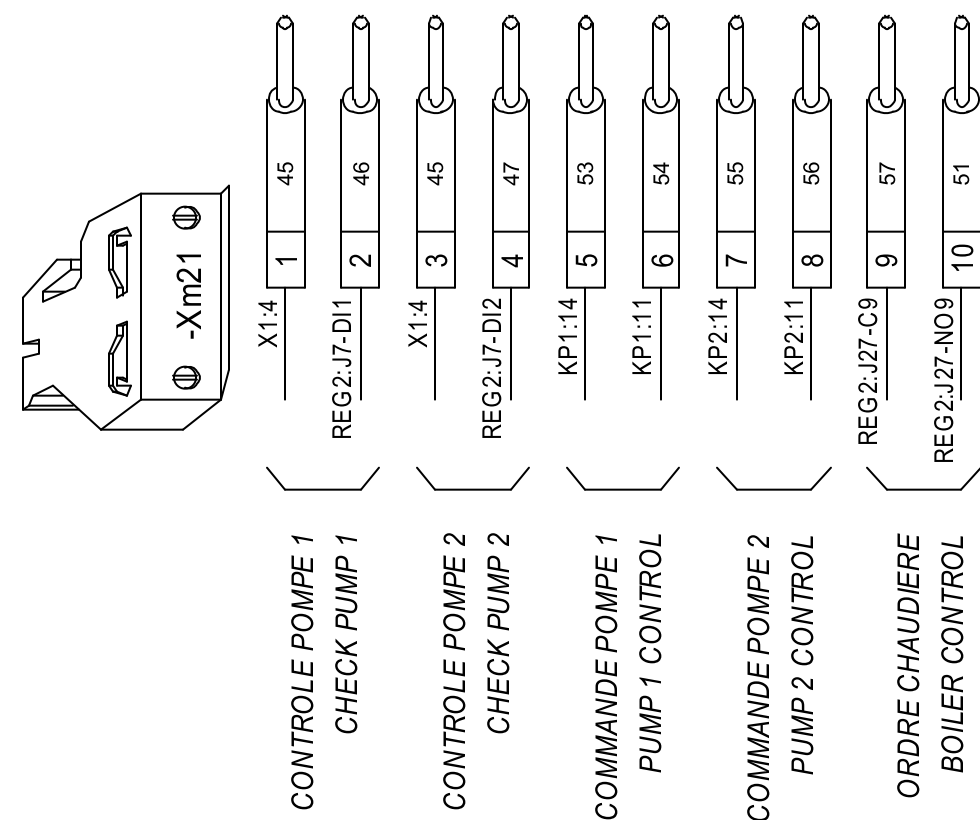

ARM

DESIGNATION :  
DESIGNATION :



Connecteurs: Xm21 et 22 (OPTIONS CLIENT)  
Connectors: Xm21 and 22 (CUSTOMER OPTIONS)

NUMERO DE SCHEMA  
DIAGRAM NUMBER

7561780

INDICE  
INDEX

01

FOLIO  
FOLIO

10/10