

SCHEMA ELECTRIQUE ELECTRICAL DIAGRAM

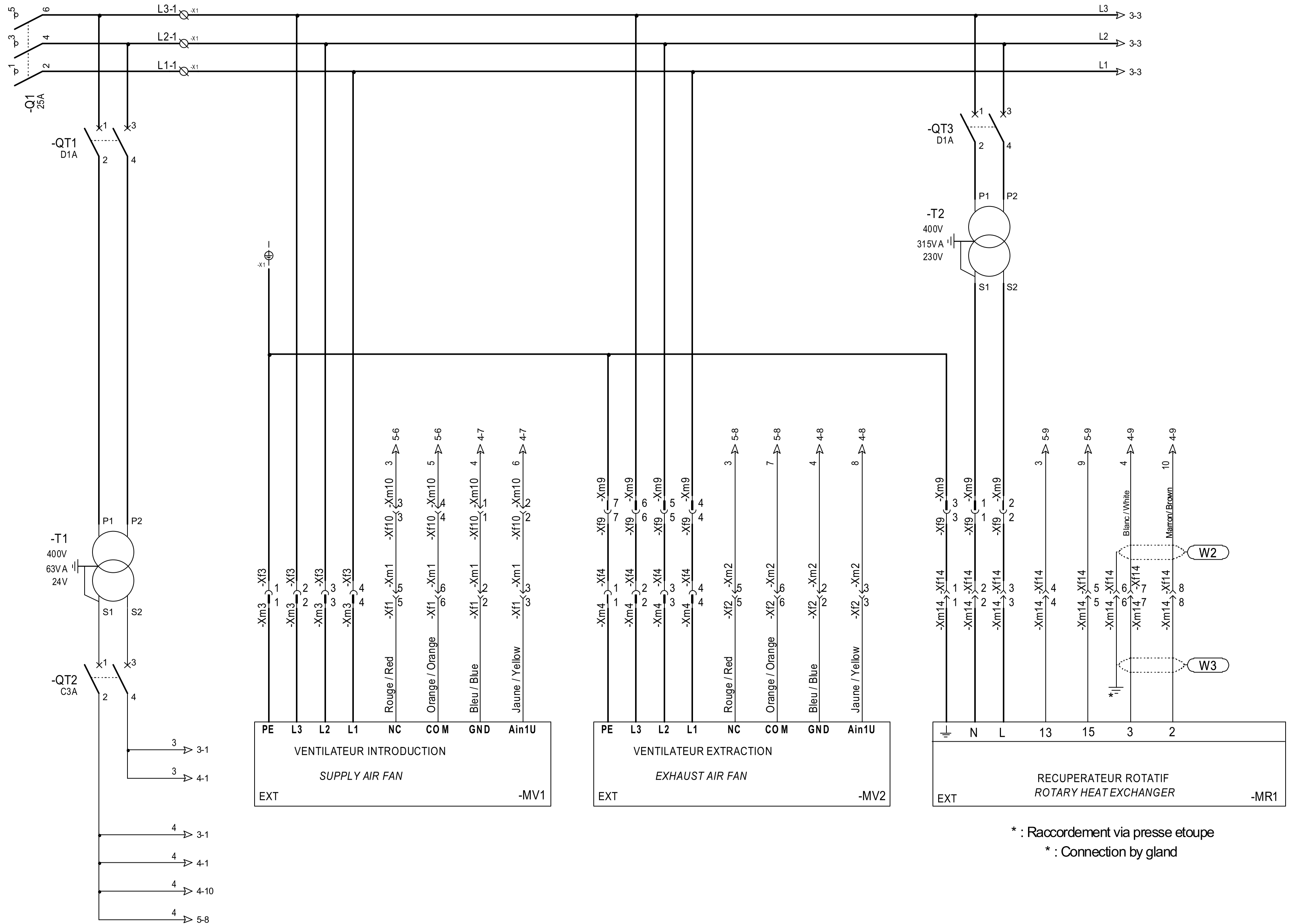

				NUMERO DE COMMANDE : ORDER NUMBER :
				CLIENT : CUSTOMER :
				APPAREIL OU UNITE : TYPE OF UNIT : CLASSIC RHE 2000
				TENSION : SUPPLY : 3~ 400V 50Hz
				REFERENCE : REFERENCE :
				DESIGNATION : DESIGNATION :
BB-AGP	27/09/2018	00	Capture	
DESS	DATE	IND	MODIFICATION	
N° OMT : 44286		CREATEUR : CREATED BY : BB-AGP		LEGENDE : LEGEND :
		DATE : 27/09/2018 DATE :		NUMERO DE SCHEMA DIAGRAM NUMBER 7553783
				INDICE INDEX 00
				FOLIO FOLIO 1/10

ALIMENTATION 3 ~ 400V 50Hz
 RACCORDEMENT SUR
 LE SECTIONNEUR
 SUPPLY 3 ~ 400V 50Hz
 CONNECTION ON
 ISOLATOR



* : Raccordement via presse etoupe
 * : Connection by gland

ARM

DESIGNATION :
 DESIGNATION :



PUISSANCE
 POWER

NUMERO DE SCHEMA
 DIAGRAM NUMBER

7553783

INDICE
 INDEX

00

FOLIO
 FOLIO

2/10

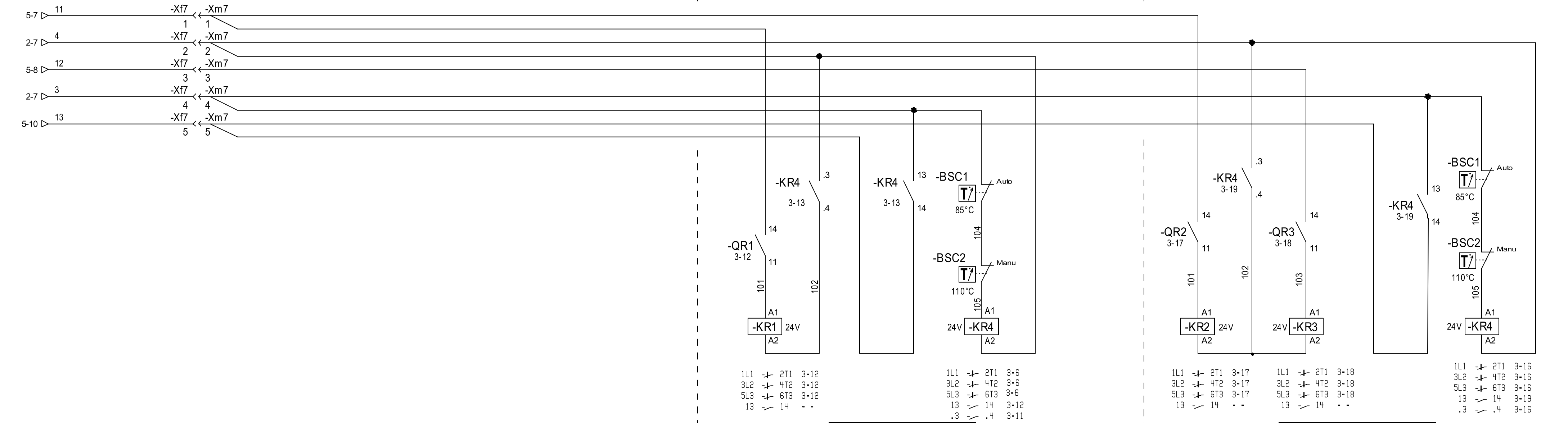
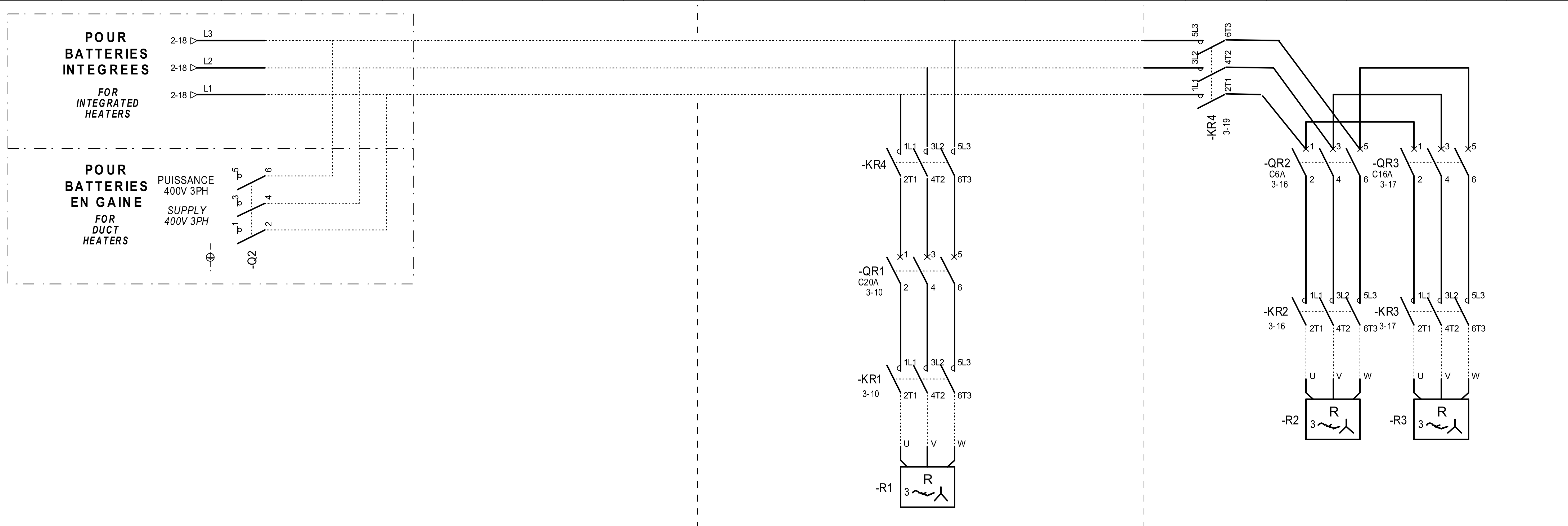

Batterie 1 étage
Step 1 electric heater

Batterie 2 étages
Step 2 electric heater

DESIGNATION :
DESIGNATION :



BATTERIES ELECTRIQUES
ELECTRIC HEATER

NUMERO DE SCHEMA
DIAGRAM NUMBER
7553783

INDICE
INDEX
00

FOLIO
FOLIO
3/10

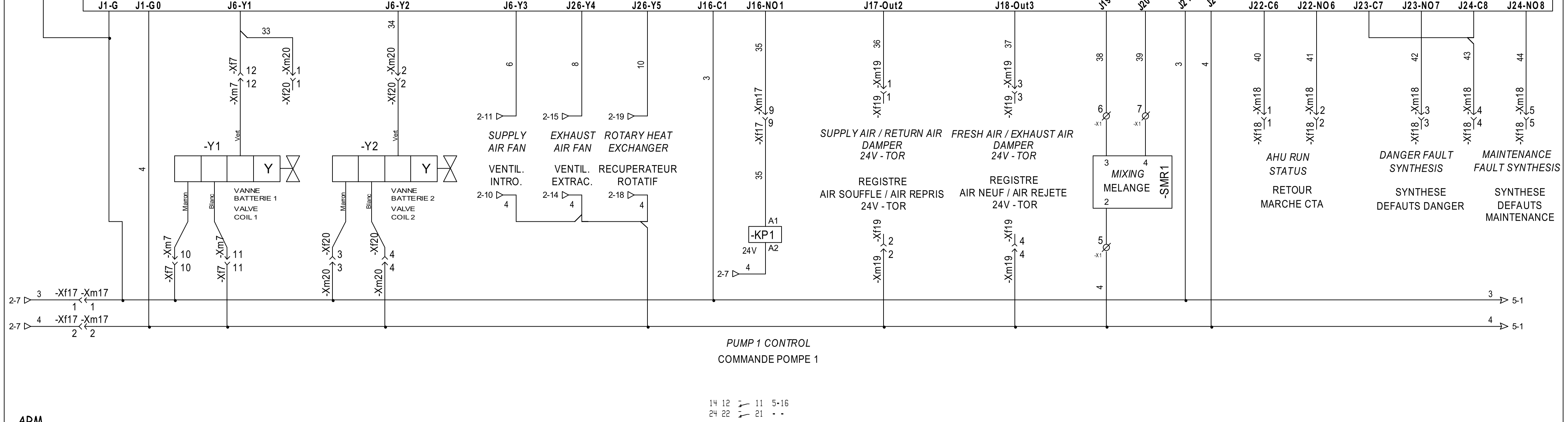
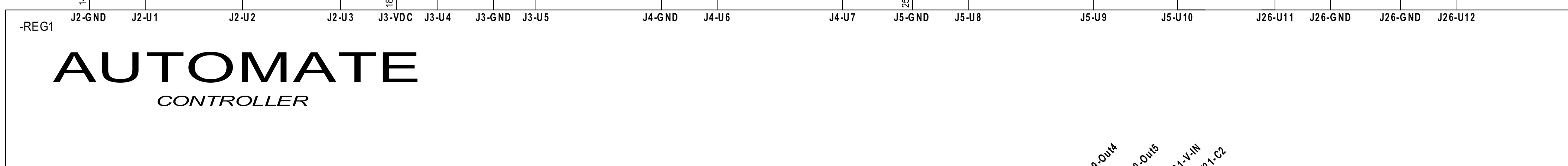
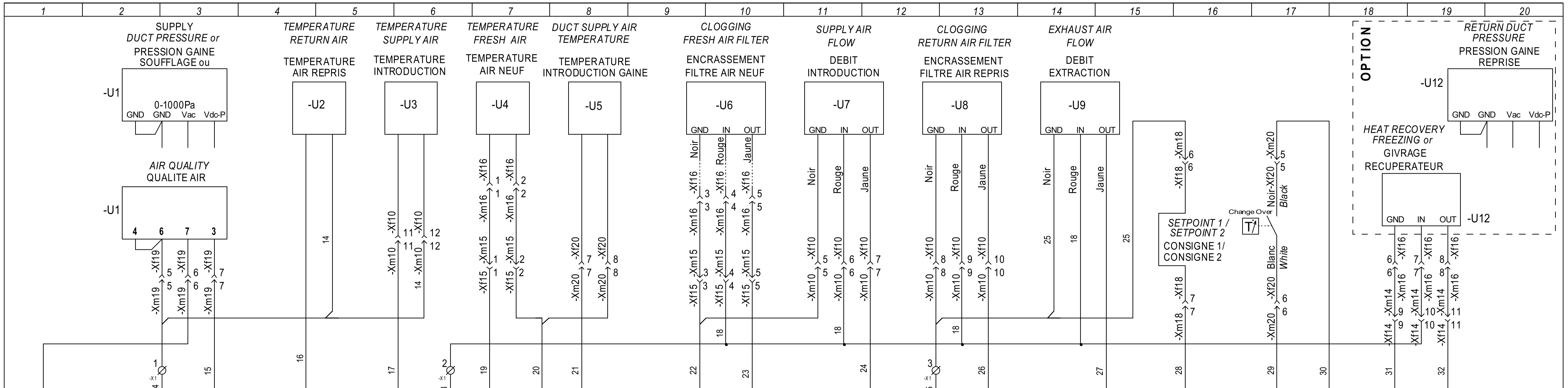

ARM

DESIGNATION :
DESIGNATION :



COMMANDE
CONTROL

NUMERO DE SCHEMA
DIAGRAM NUMBER
7553783

INDICE
INDEX
00

FOLIO
FOLIO
4/10

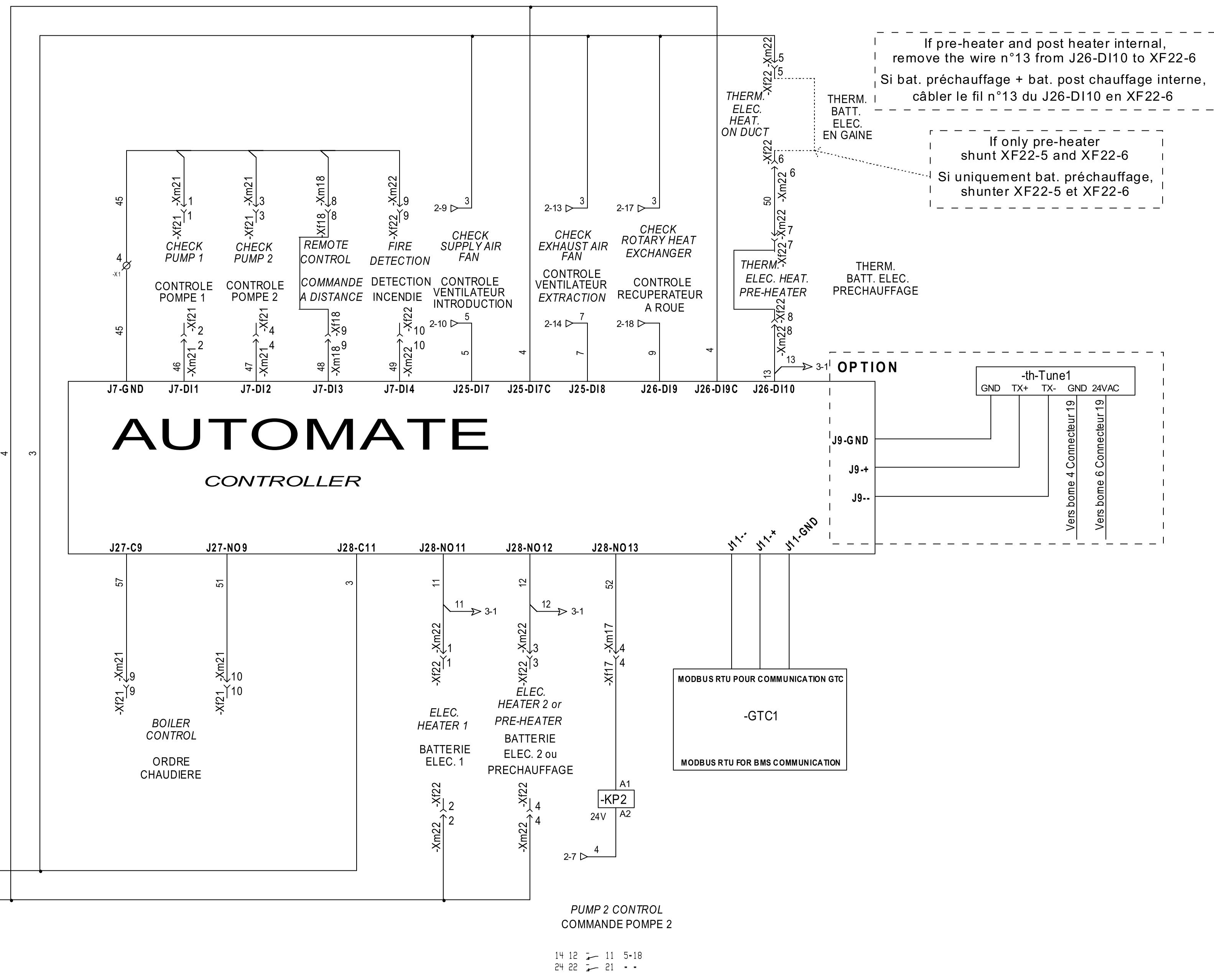

If pre-heater and post heater internal, remove the wire n°13 from J26-DI10 to XF22-6
 Si bat. préchauffage + bat. post chauffage interne, câbler le fil n°13 du J26-DI10 en XF22-6

If only pre-heater shunt XF22-5 and XF22-6
 Si uniquement bat. préchauffage, shunter XF22-5 et XF22-6

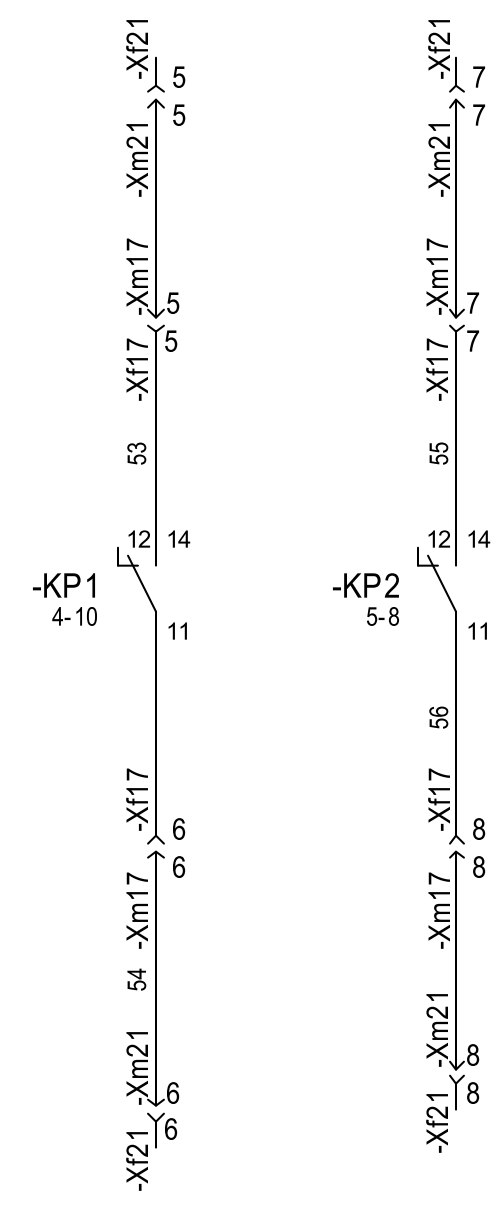
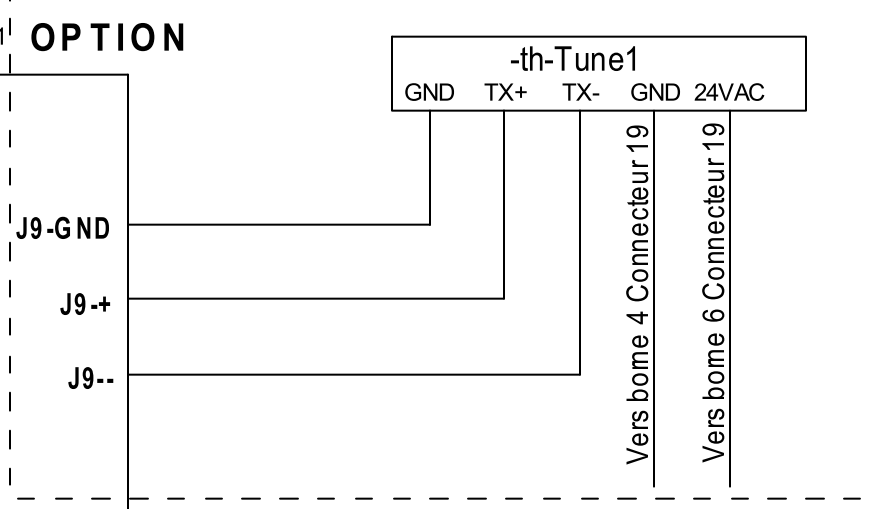

14 12 11 5-18
 24 22 21 ..

ARM

DESIGNATION :
 DESIGNATION :



COMMANDE -2
 CONTROL -2

NUMERO DE SCHEMA DIAGRAM NUMBER	INDICE INDEX	FOLIO FOLIO
7553783	00	5/10

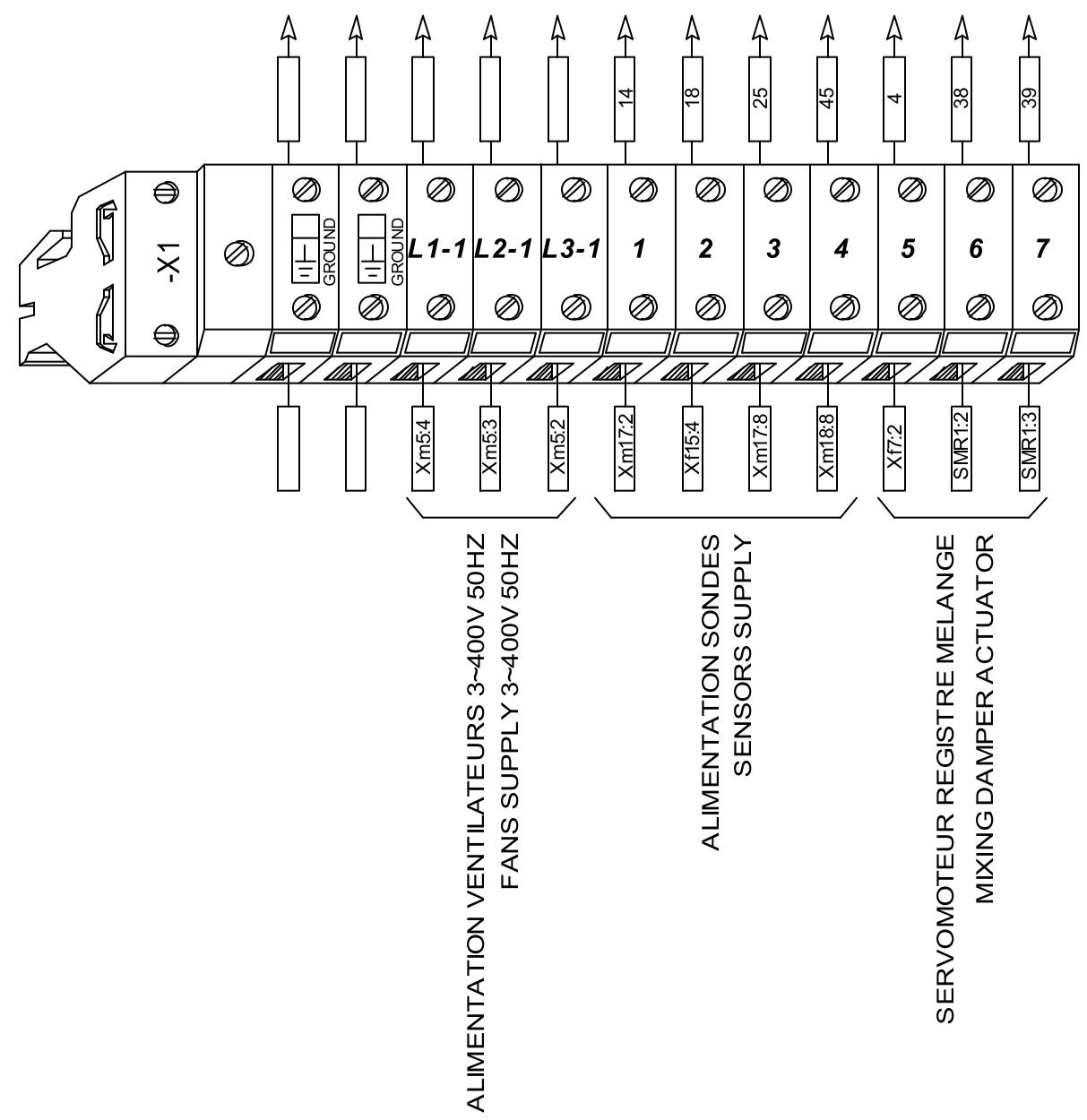

ARM

DESIGNATION :
DESIGNATION :



Bornier : X1
Terminal : X1

NUMERO DE SCHEMA
DIAGRAM NUMBER
7553783

INDICE
INDEX
00

FOLIO
FOLIO
6/10

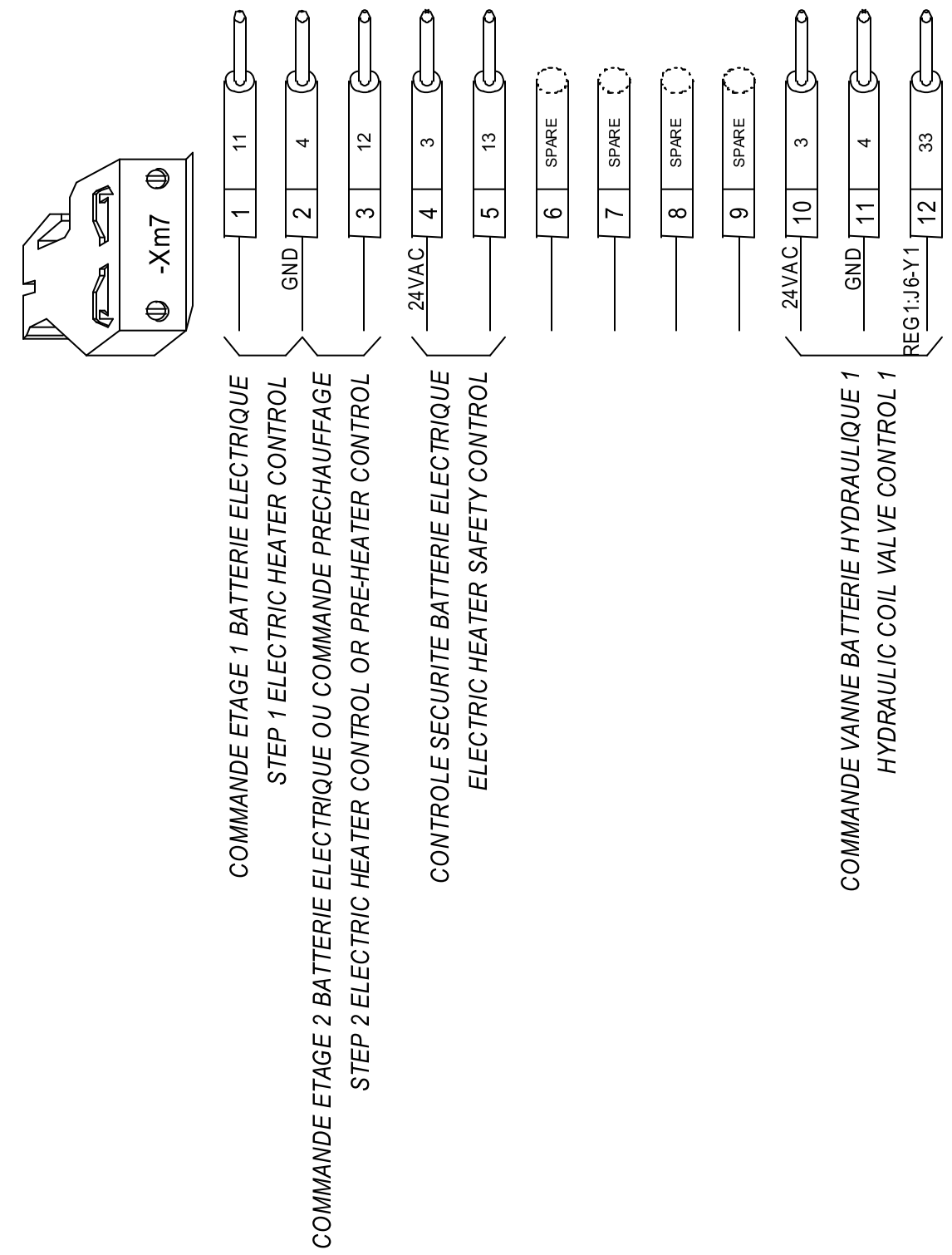
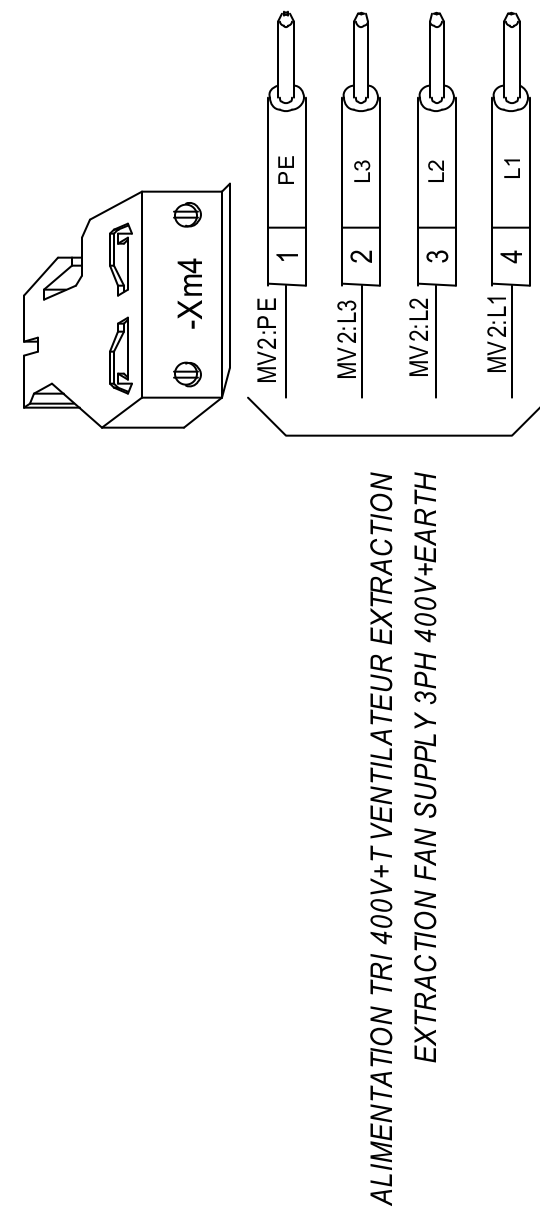
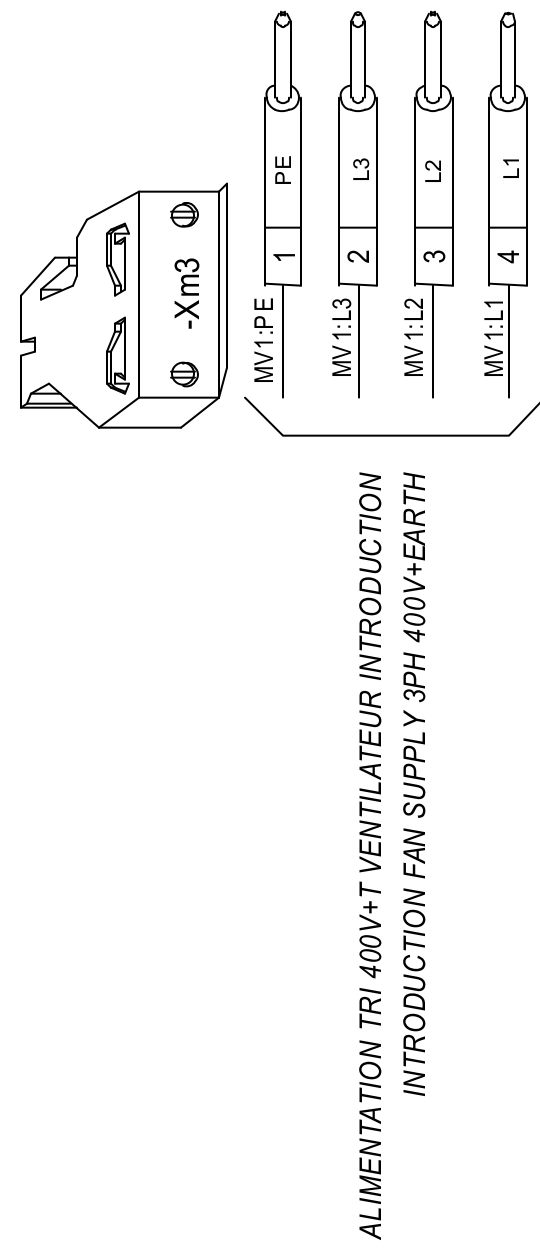
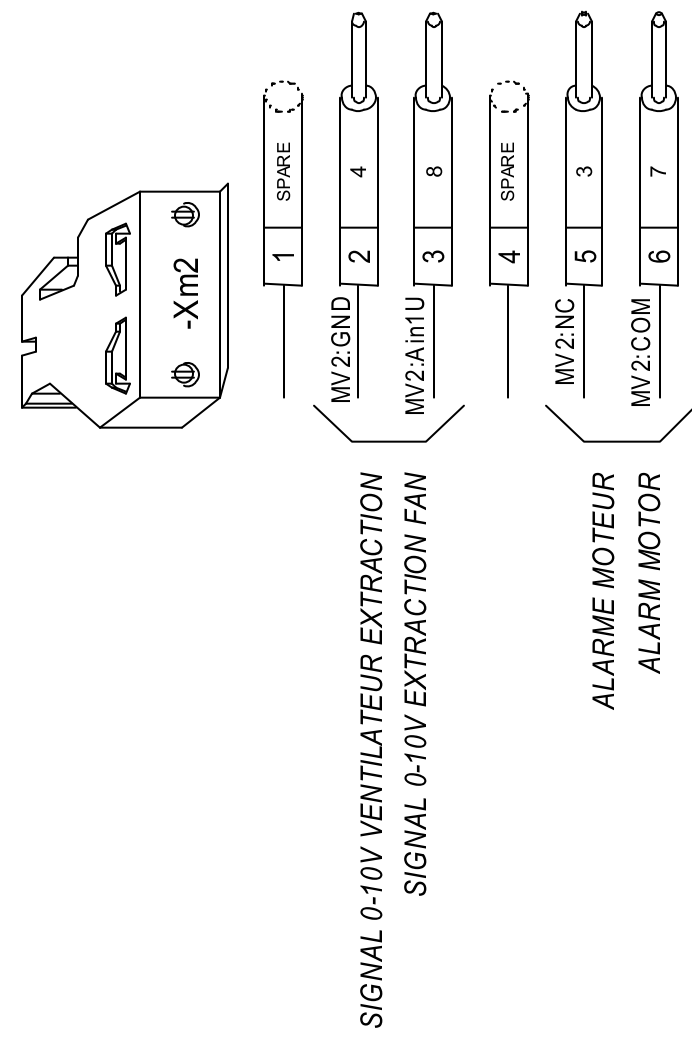
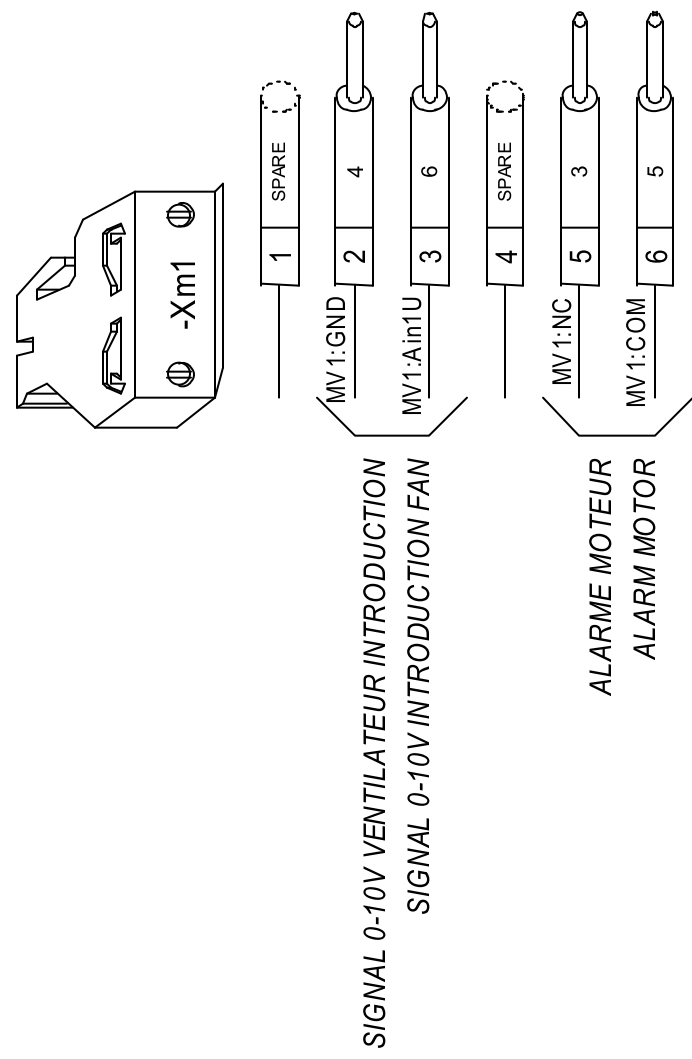

ARM

DESIGNATION :
DESIGNATION :



Connecteurs: Xm1, 2, 3, 4 et 7
Connectors: Xm1, 2, 3, 4 and 7

NUMERO DE SCHEMA
DIAGRAM NUMBER
7553783

INDICE
INDEX
00

FOLIO
FOLIO
7/10

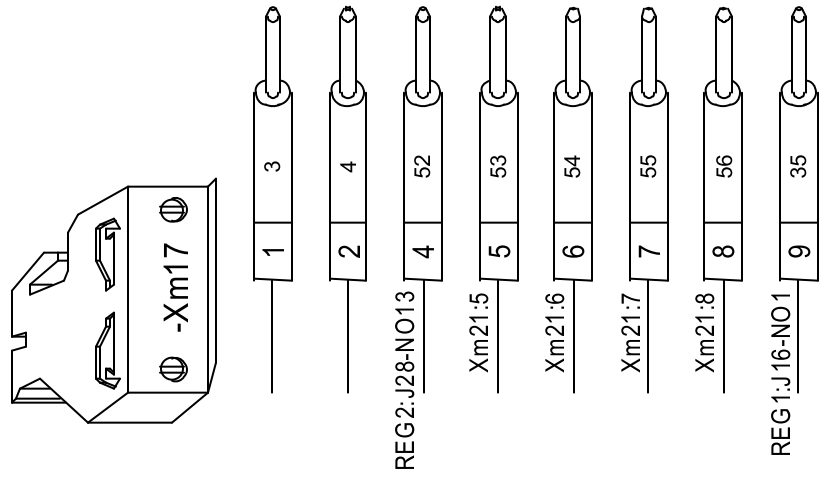
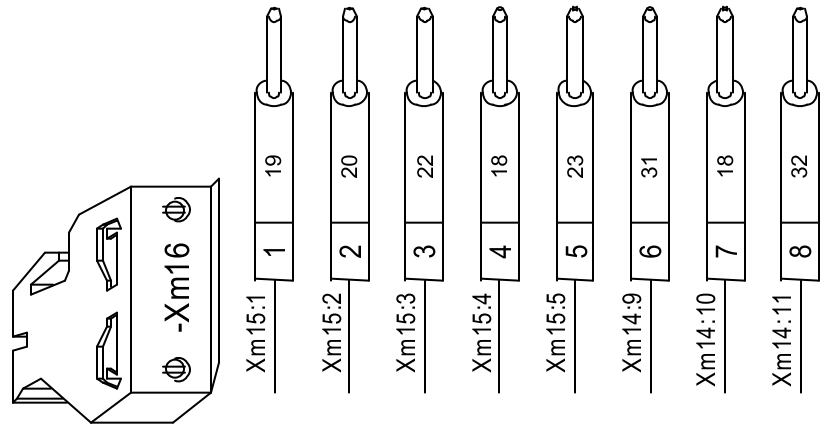
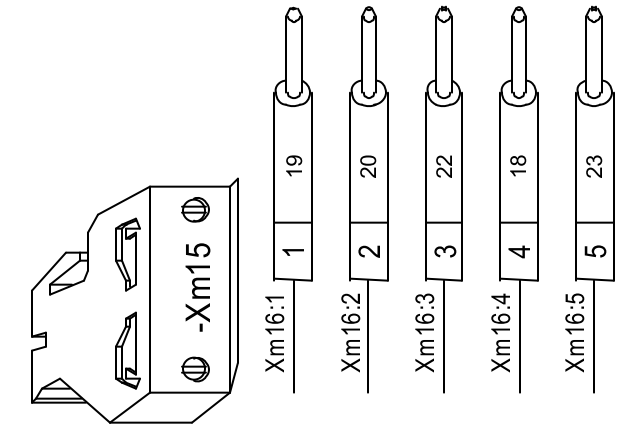
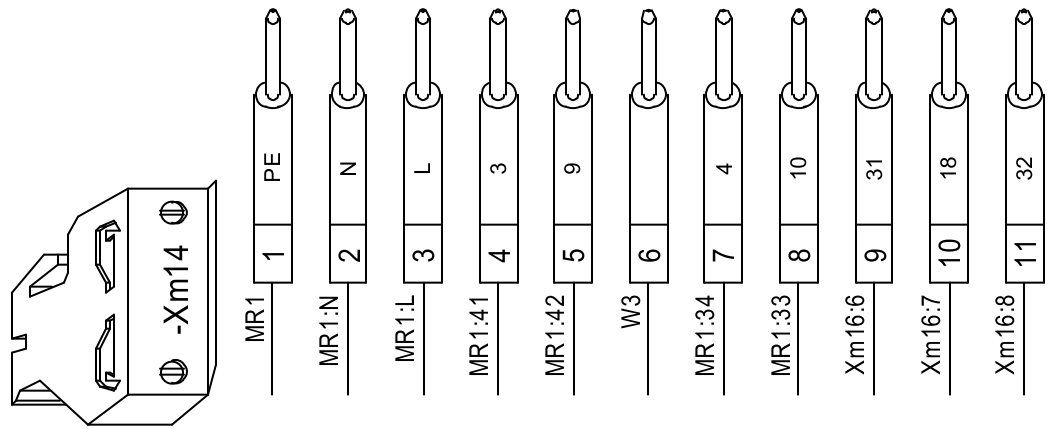
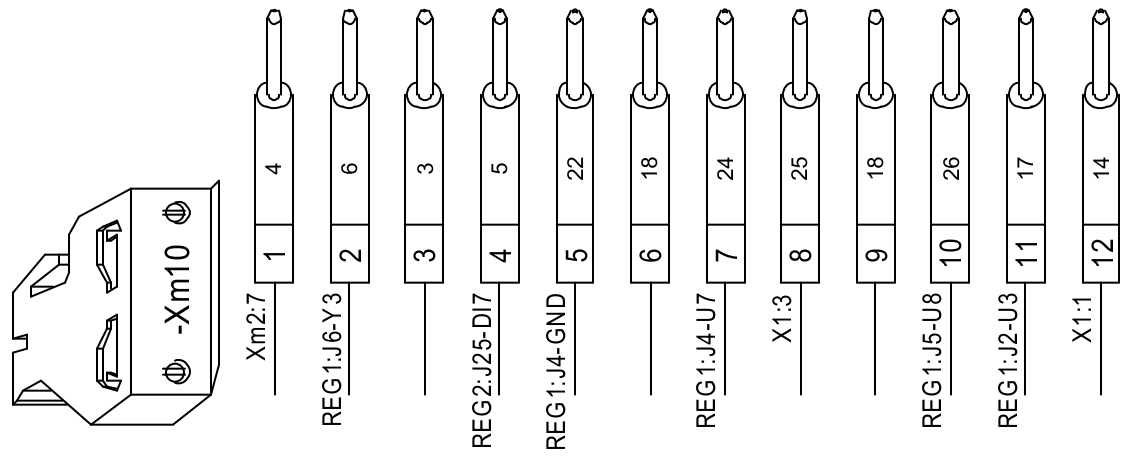
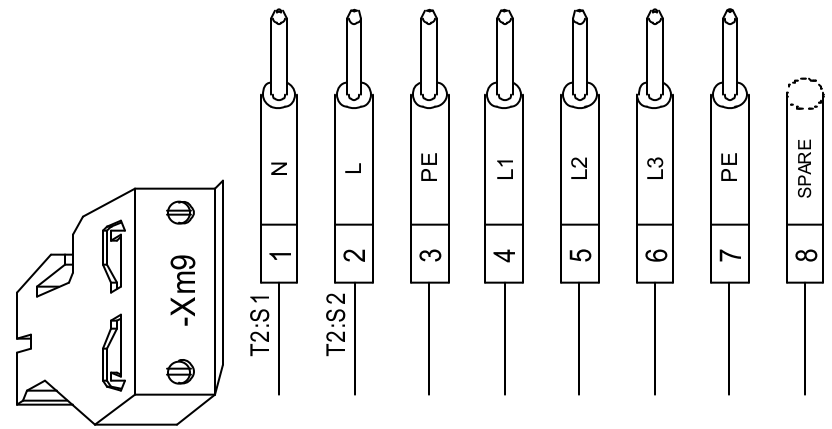

ARM

DESIGNATION :
DESIGNATION :



Connecteur: Xm9, 10, 14, 15, 16 et 17
Connectors: Xm9, 10, 14, 15, 16 et 17

NUMERO DE SCHEMA
DIAGRAM NUMBER
7553783

INDICE
INDEX
00

FOLIO
FOLIO
8/10

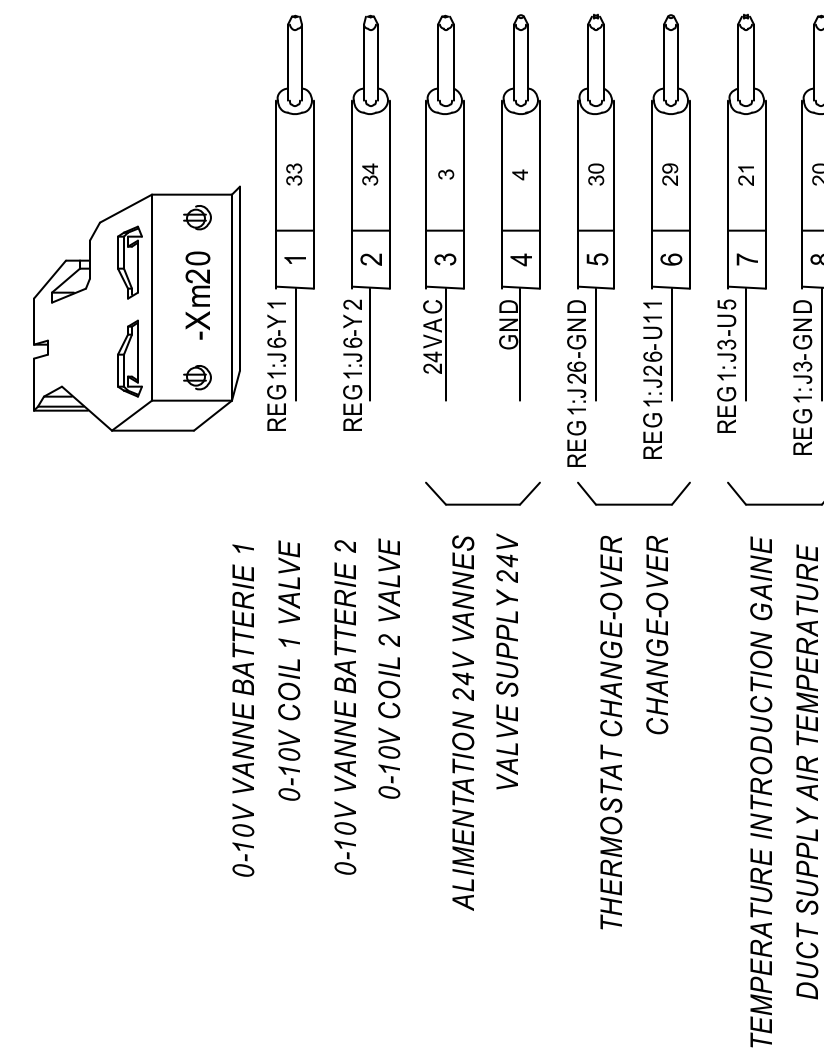
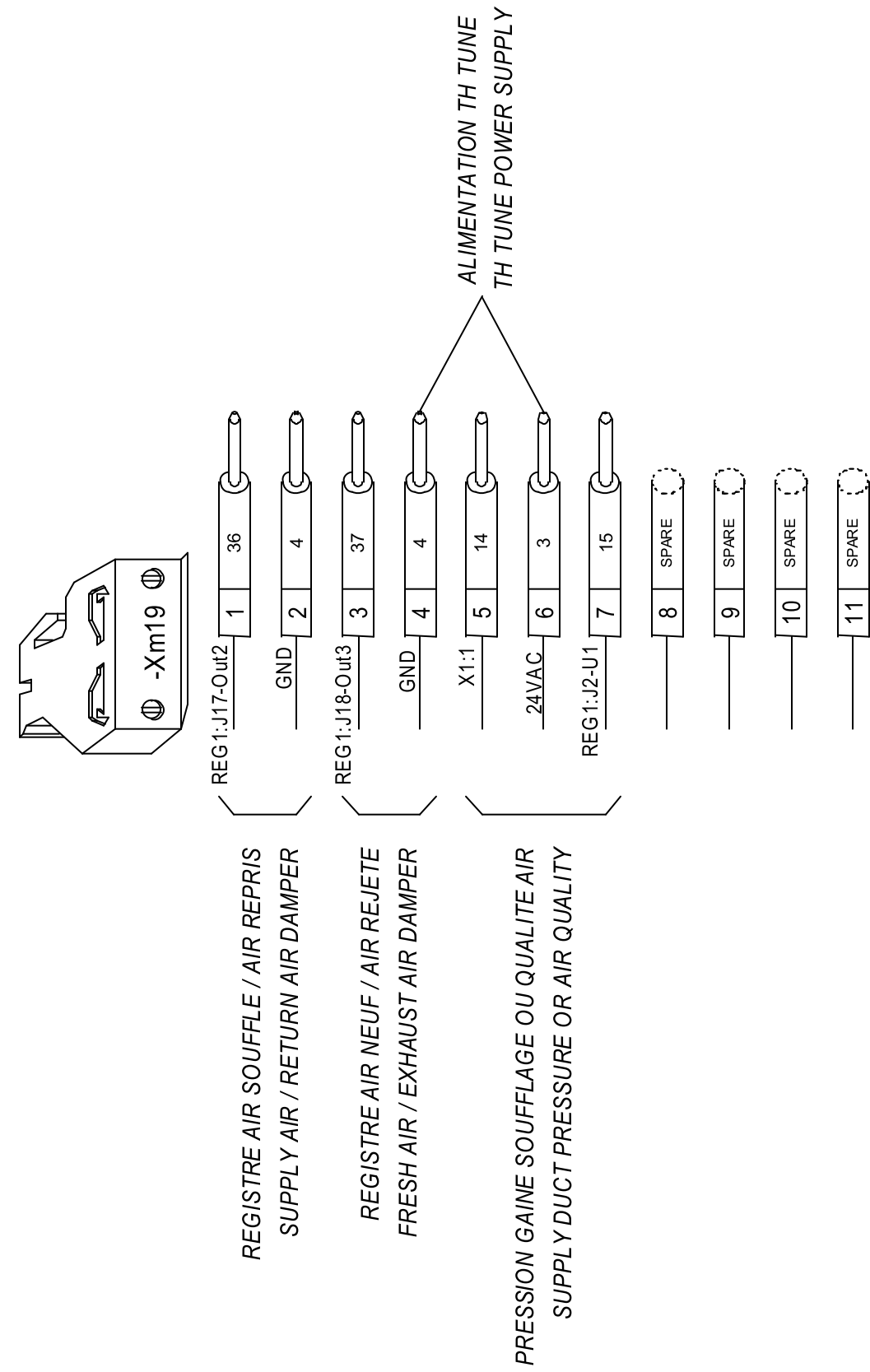
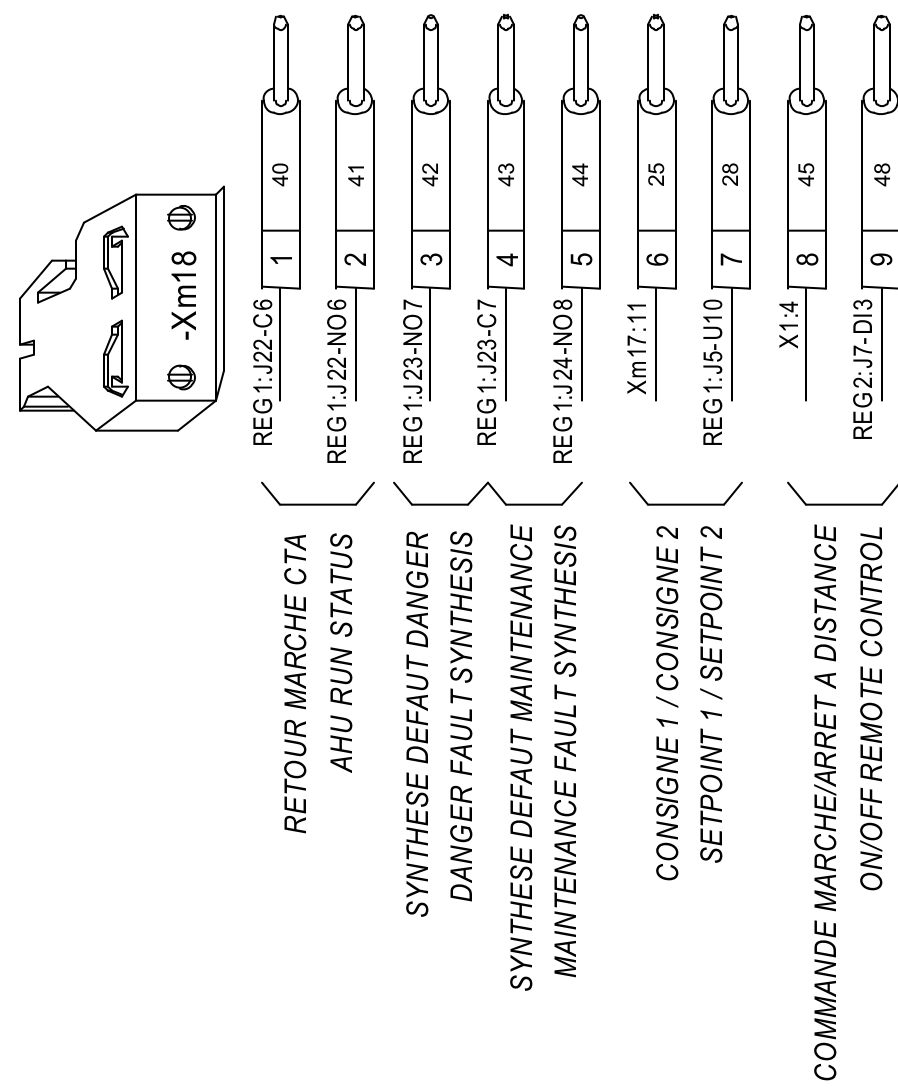

ARM

DESIGNATION :
DESIGNATION :



Connecteurs: Xm18, 19 et 20 (OPTIONS CLIENT)
Connectors: Xm18, 19 et 20 (CUSTOMER OPTIONS)

NUMERO DE SCHEMA
DIAGRAM NUMBER
7553783

INDICE
INDEX
00

FOLIO
FOLIO
9/10

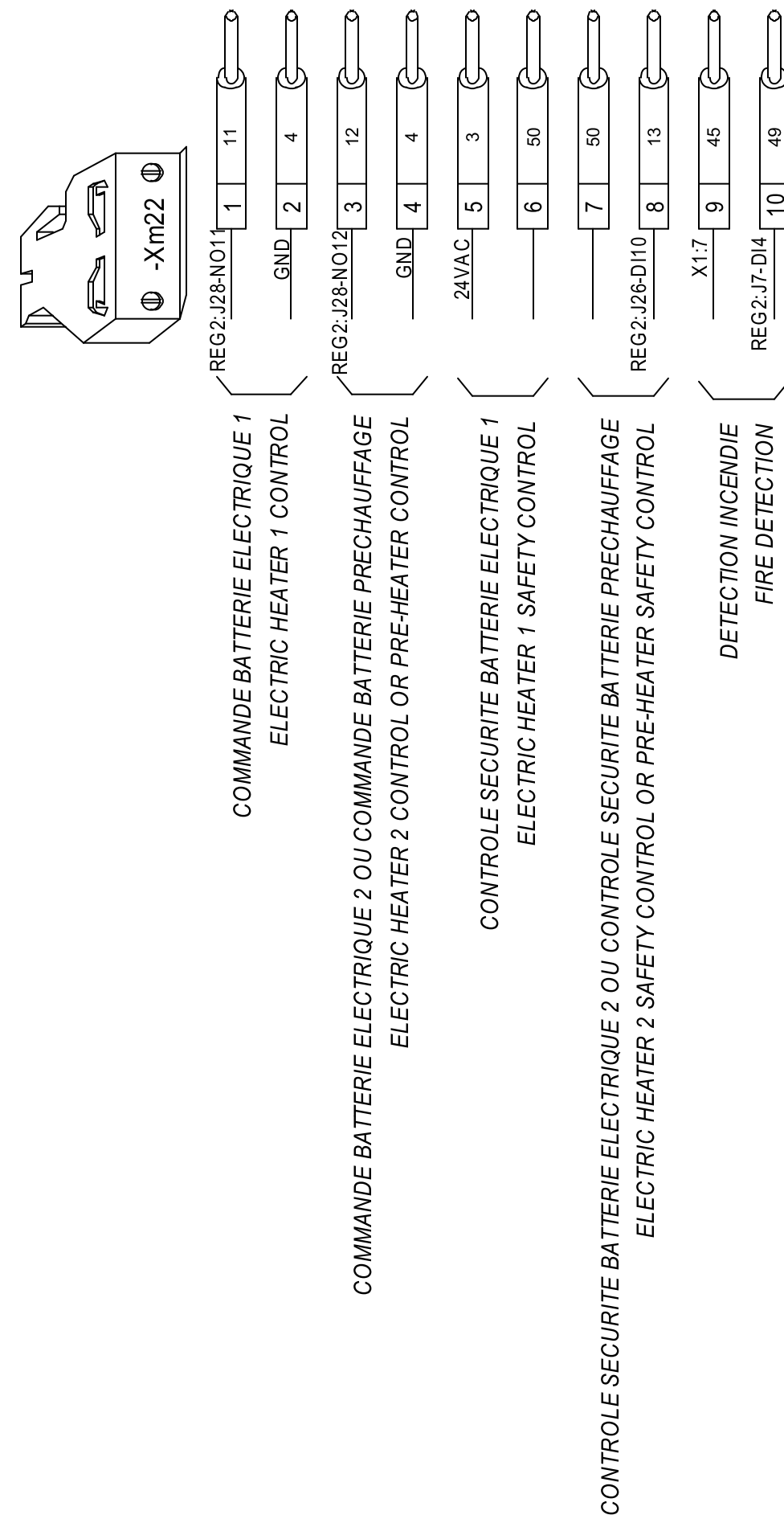
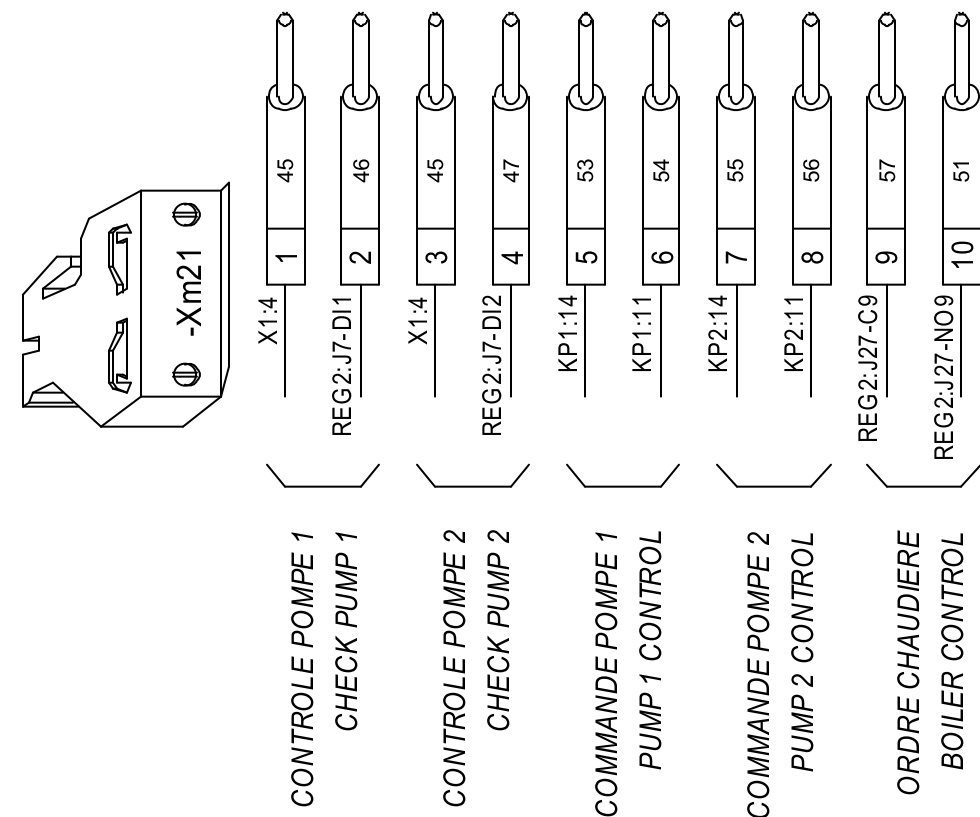

ARM

DESIGNATION :
DESIGNATION :



Connecteurs: Xm21 et 22 (OPTIONS CLIENT)
Connectors: Xm21 and 22 (CUSTOMER OPTIONS)

NUMERO DE SCHEMA
DIAGRAM NUMBER
7553783

INDICE
INDEX
00

FOLIO
FOLIO
10/10