

SCHEMA ELECTRIQUE ELECTRICAL DIAGRAM



				NUMERO DE COMMANDE : ORDER NUMBER :
				CLIENT : CUSTOMER :
				APPAREIL OU UNITE : DF CLRZ 1000 TYPE OF UNIT :
				TENSION : 1/N ~ 230V 50Hz + PE SUPPLY :
				REFERENCE : REFERENCE :
				DESIGNATION : DESIGNATION :
BFR-AGP	02/04/2021	00	CREATION	
DESS	DATE	IND	MODIFICATION	
N° OMT :		CREATEUR : BFR-AGP CREATED BY :		LEGENDE : LEGEND :
		DATE : 02/04/2021 DATE :		NUMERO DE SCHEMA DIAGRAM NUMBER 7590350
				INDICE INDEX 00
				FOLIO FOLIO 1/8

ALIMENTATION
1/N ~ 230V 50Hz + PE
RACCORDEMENT SUR
LE SECTIONNEUR
SUPPLY
1/N ~ 230V 50Hz + PE
CONNECTION ON
ISOLATOR

CALIBRES SECTIONNEURS FLOWAY RHEZ
DISCONNECTOR RATINGS FOR FLOWAY RHEZ

	Q1 Sans batterie electrique interne Without internal electric heater	Q1 Avec batterie electrique interne With internal electric heater	Q2 Caisson additionnel batterie electrique Additional box electric heater
CLASSIC RHEZ 1000	OT40 (40A)	OT40 (40A)	OT40 (40A)

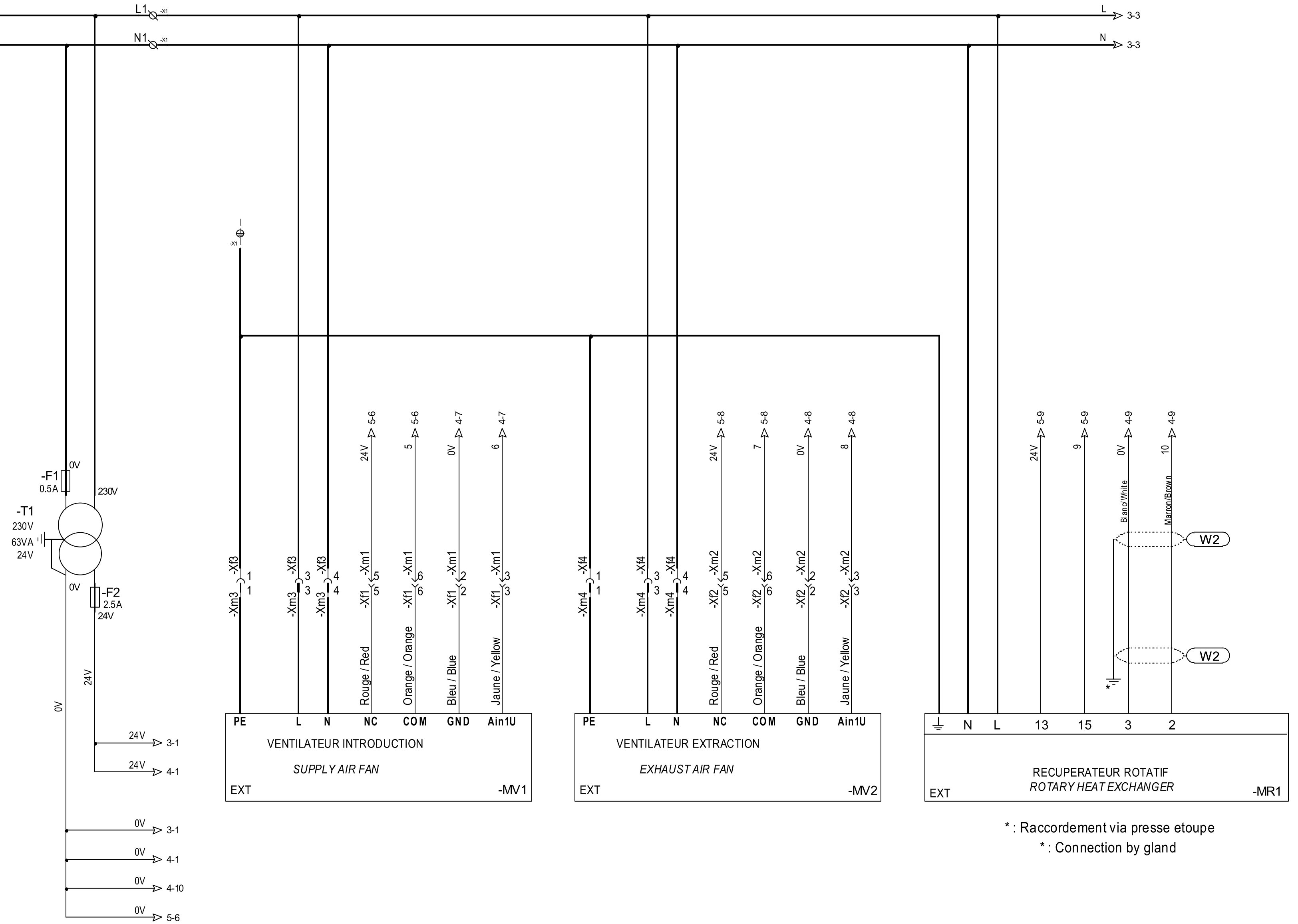
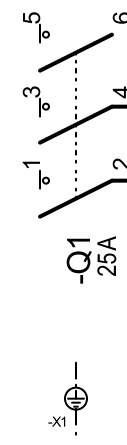

* : Raccordement via presse etoupe
* : Connection by gland

ARM

DESIGNATION :
DESIGNATION :



PUISSANCE
POWER

NUMERO DE SCHEMA
DIAGRAM NUMBER

7590350

INDICE
INDEX

00

FOLIO
FOLIO

2/8

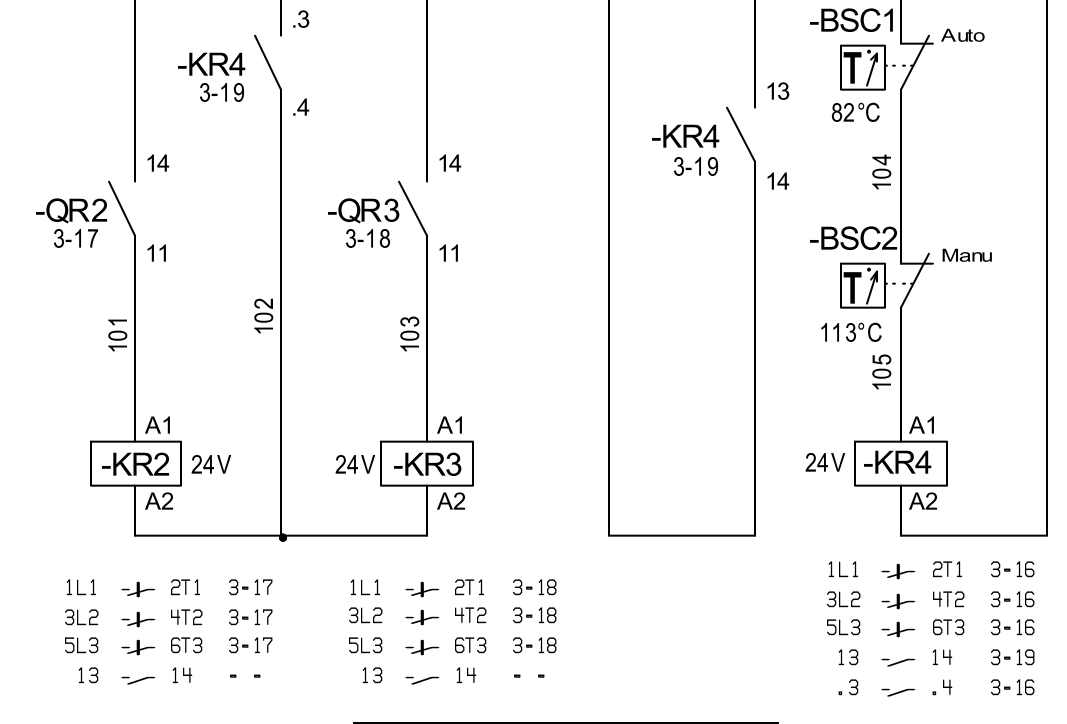
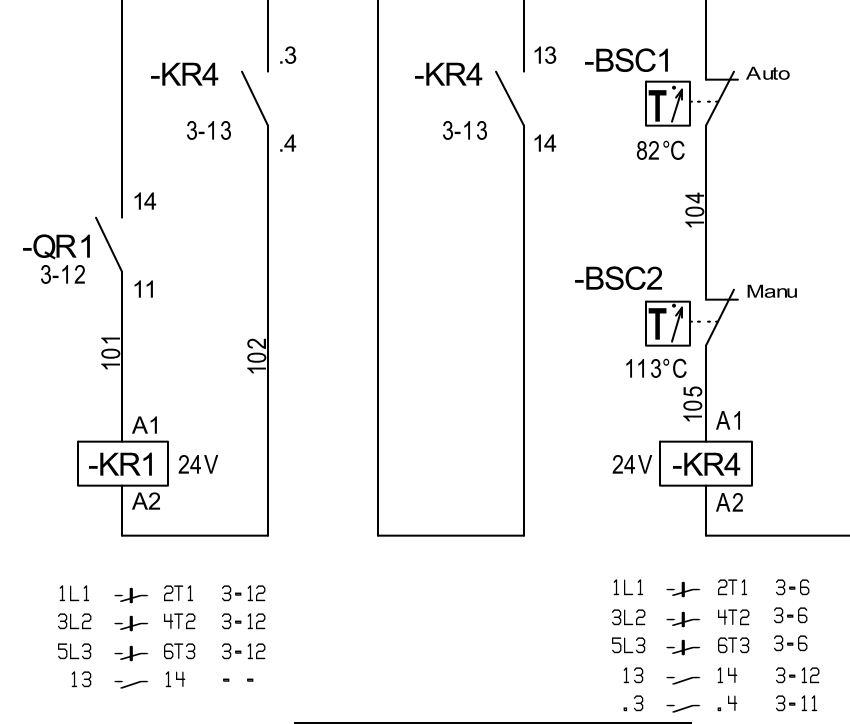
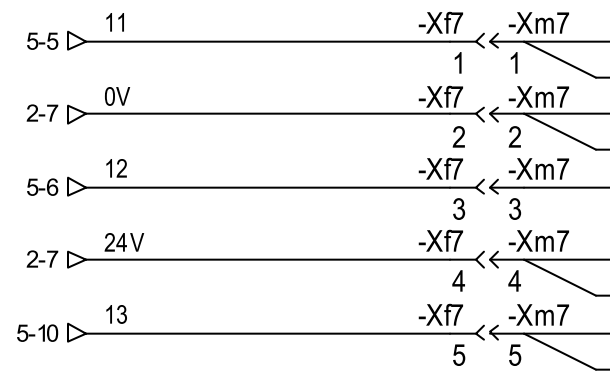
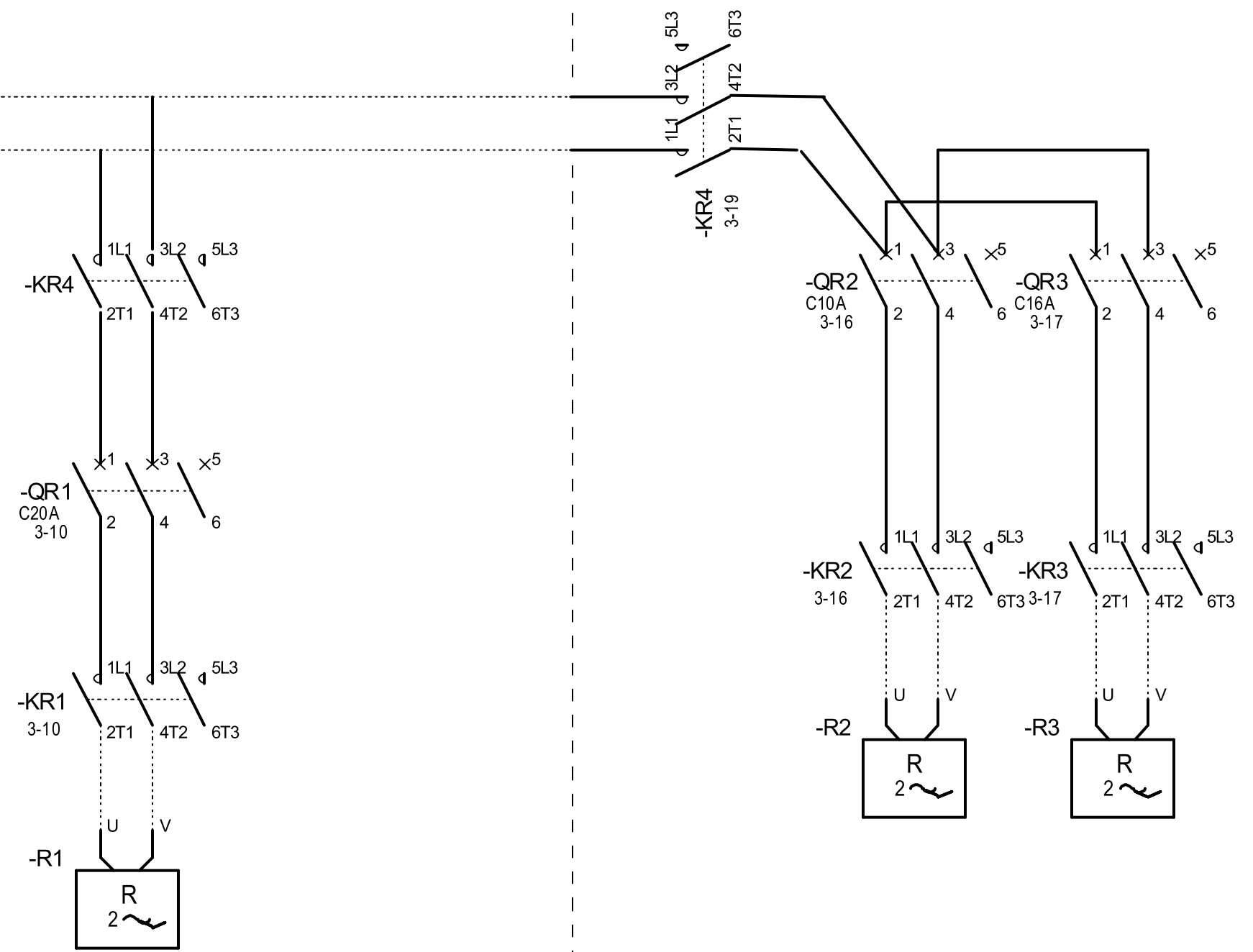
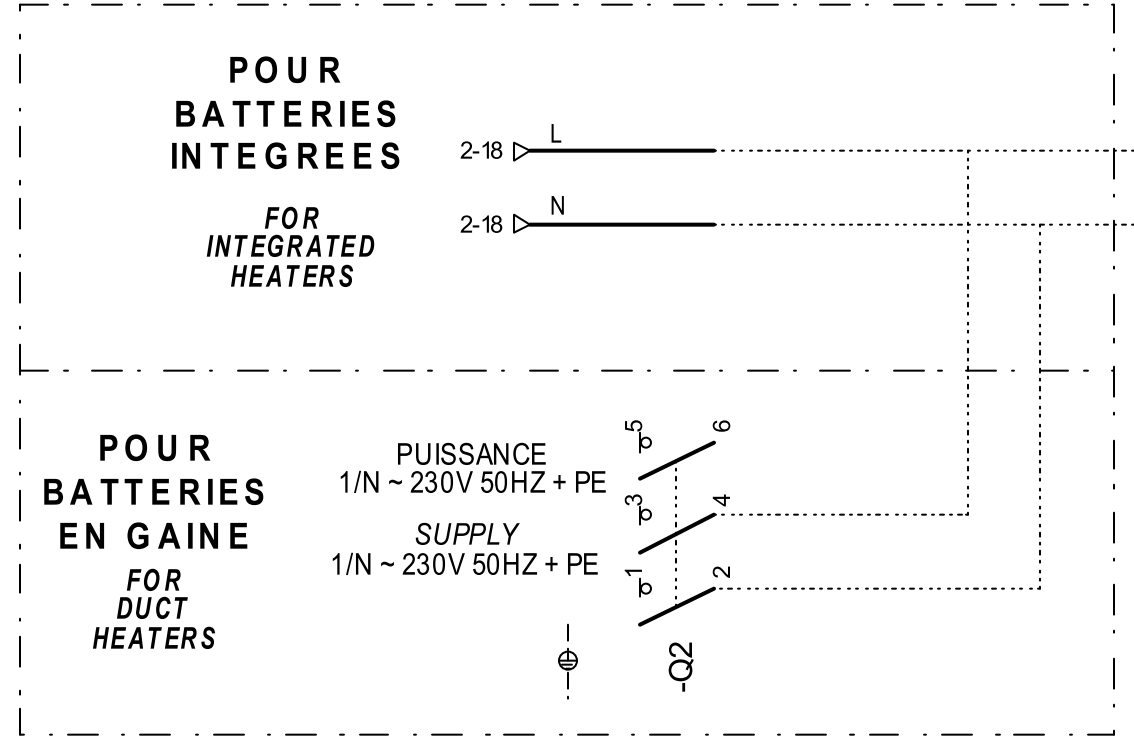

DESIGNATION :
DESIGNATION :



**BATTERIES ELECTRIQUES
ELECTRIC HEATER**

NUMERO DE SCHEMA
DIAGRAM NUMBER

7590350

INDICE
INDEX

00

FOLIO
FOLIO

3/8

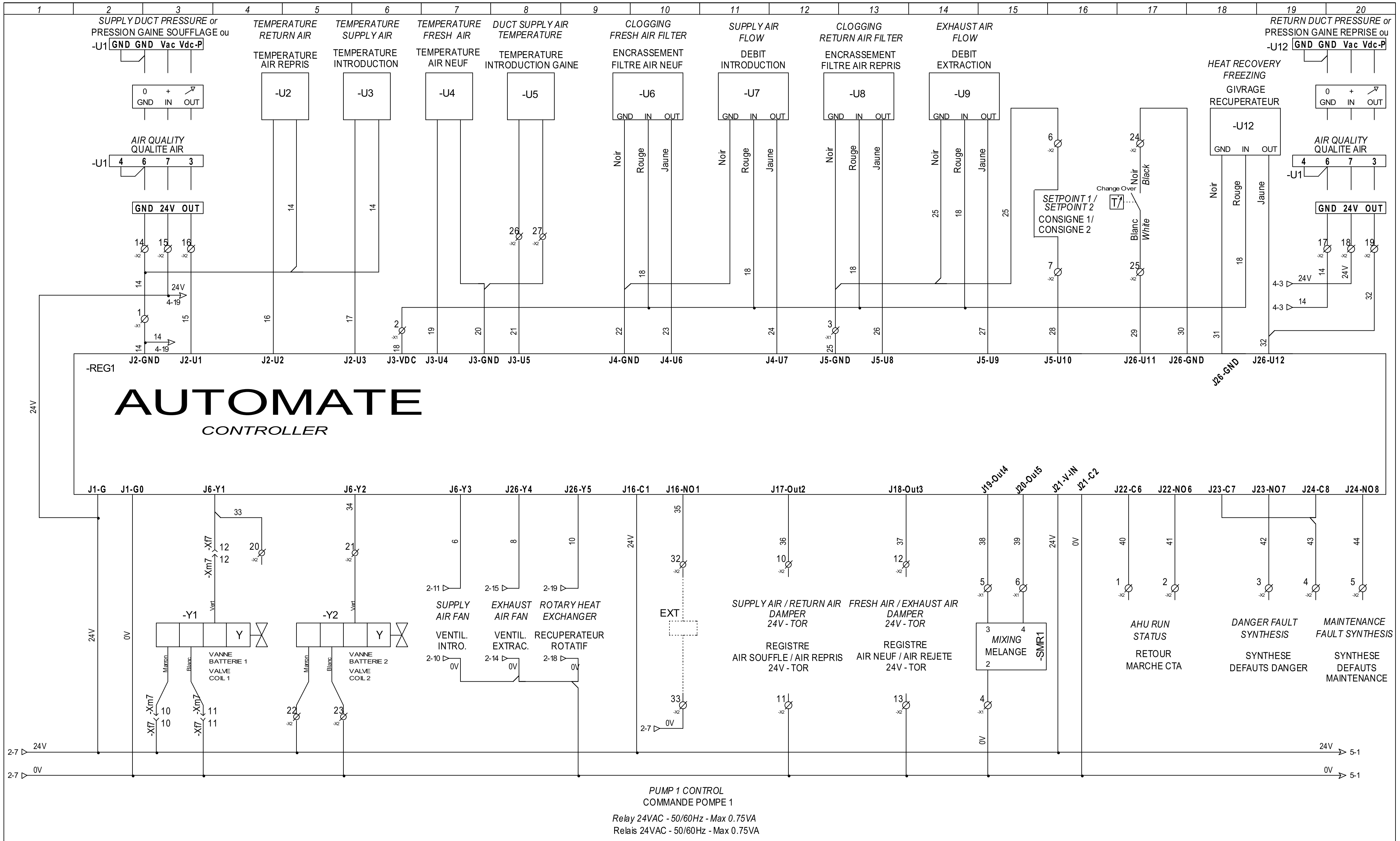

ARM

DESIGNATION :
 DESIGNATION :



COMMANDE CONTROL

NUMERO DE SCHEMA
 DIAGRAM NUMBER
7590350

INDICE
 INDEX
00

FOLIO
 FOLIO
4/8

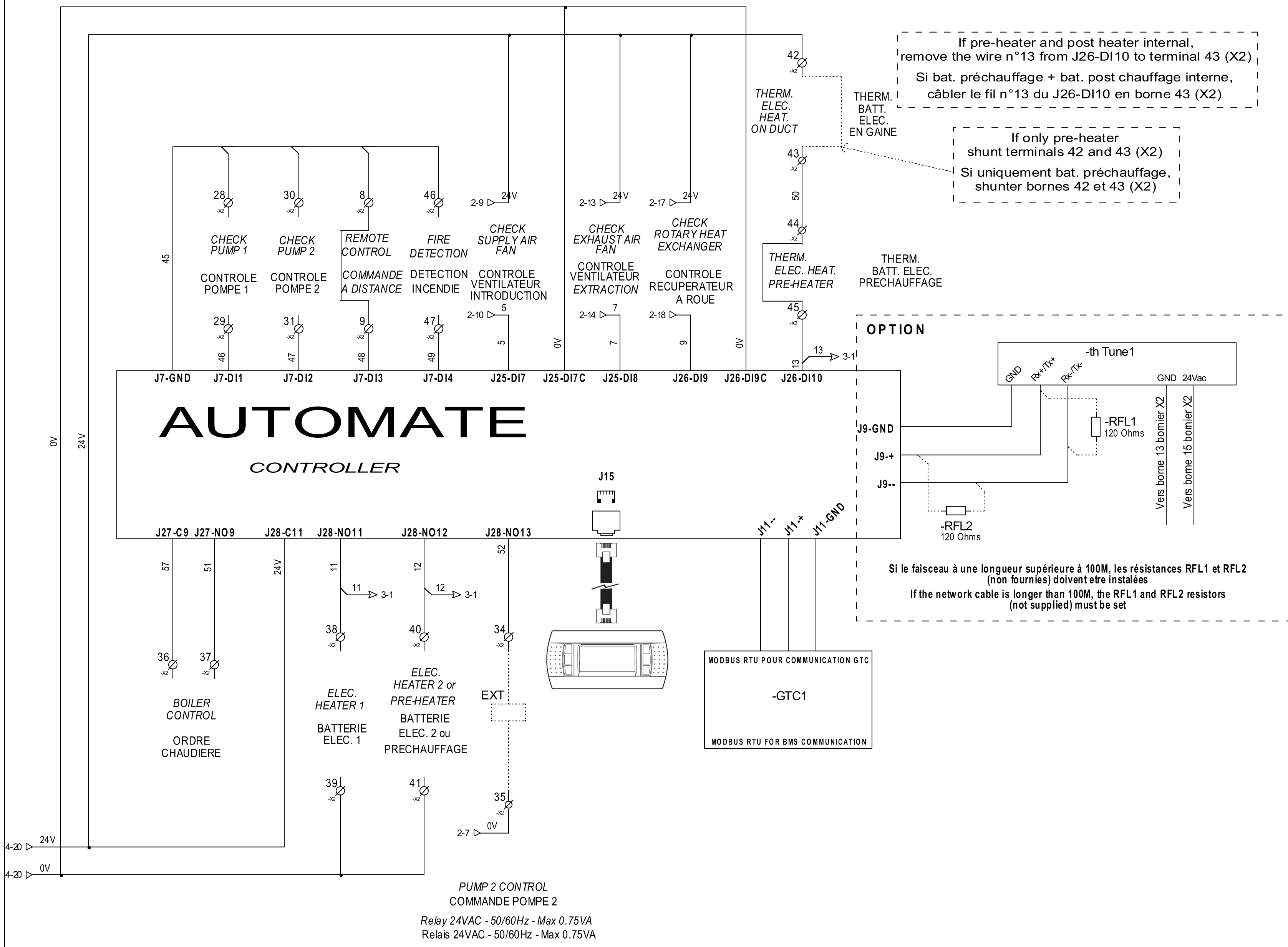

If pre-heater and post heater internal, remove the wire n°13 from J26-DI10 to terminal 43 (X2)
 Si bat. préchauffage + bat. post chauffage interne, câbler le fil n°13 du J26-DI10 en borne 43 (X2)

If only pre-heater shunt terminals 42 and 43 (X2)
 Si uniquement bat. préchauffage, shunter bornes 42 et 43 (X2)

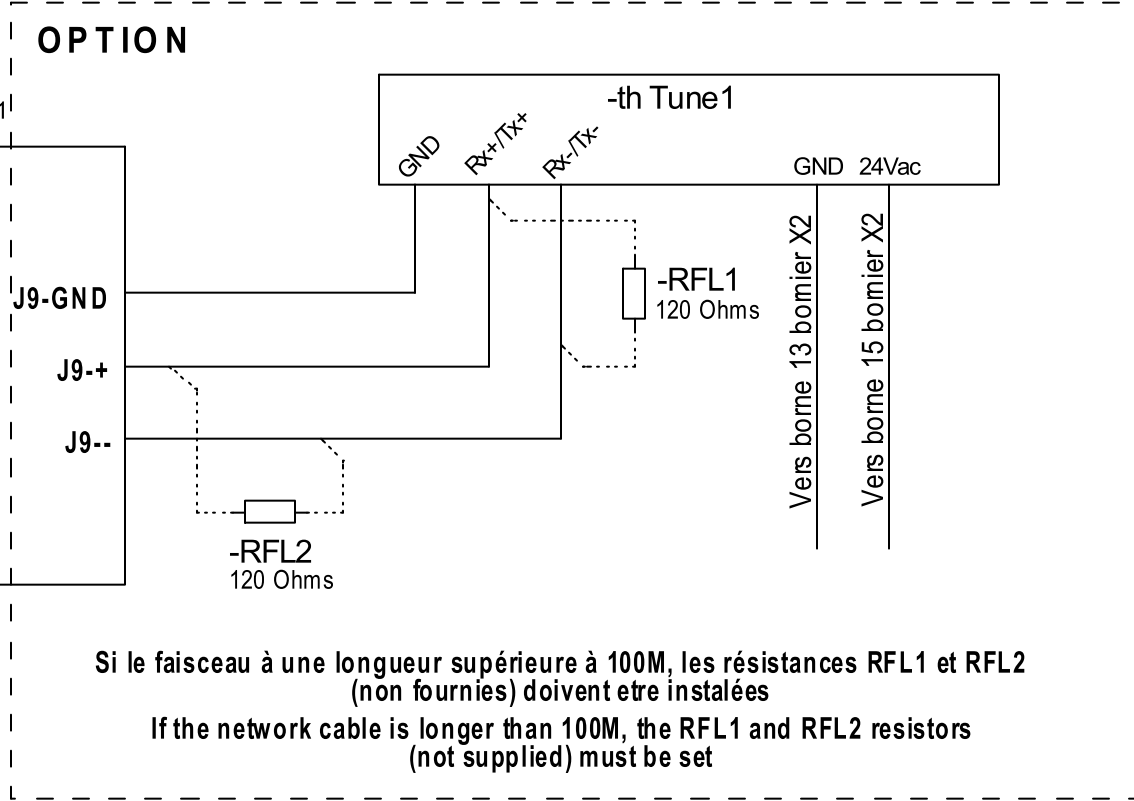

Si le faisceau à une longueur supérieure à 100M, les résistances RFL1 et RFL2 (non fournies) doivent être installées
 If the network cable is longer than 100M, the RFL1 and RFL2 resistors (not supplied) must be set

ARM

DESIGNATION :
 DESIGNATION :



COMMANDE - 2
 CONTROL - 2

NUMERO DE SCHEMA
 DIAGRAM NUMBER
 7590350

INDICE
 INDEX
 00

FOLIO
 FOLIO
 5/8

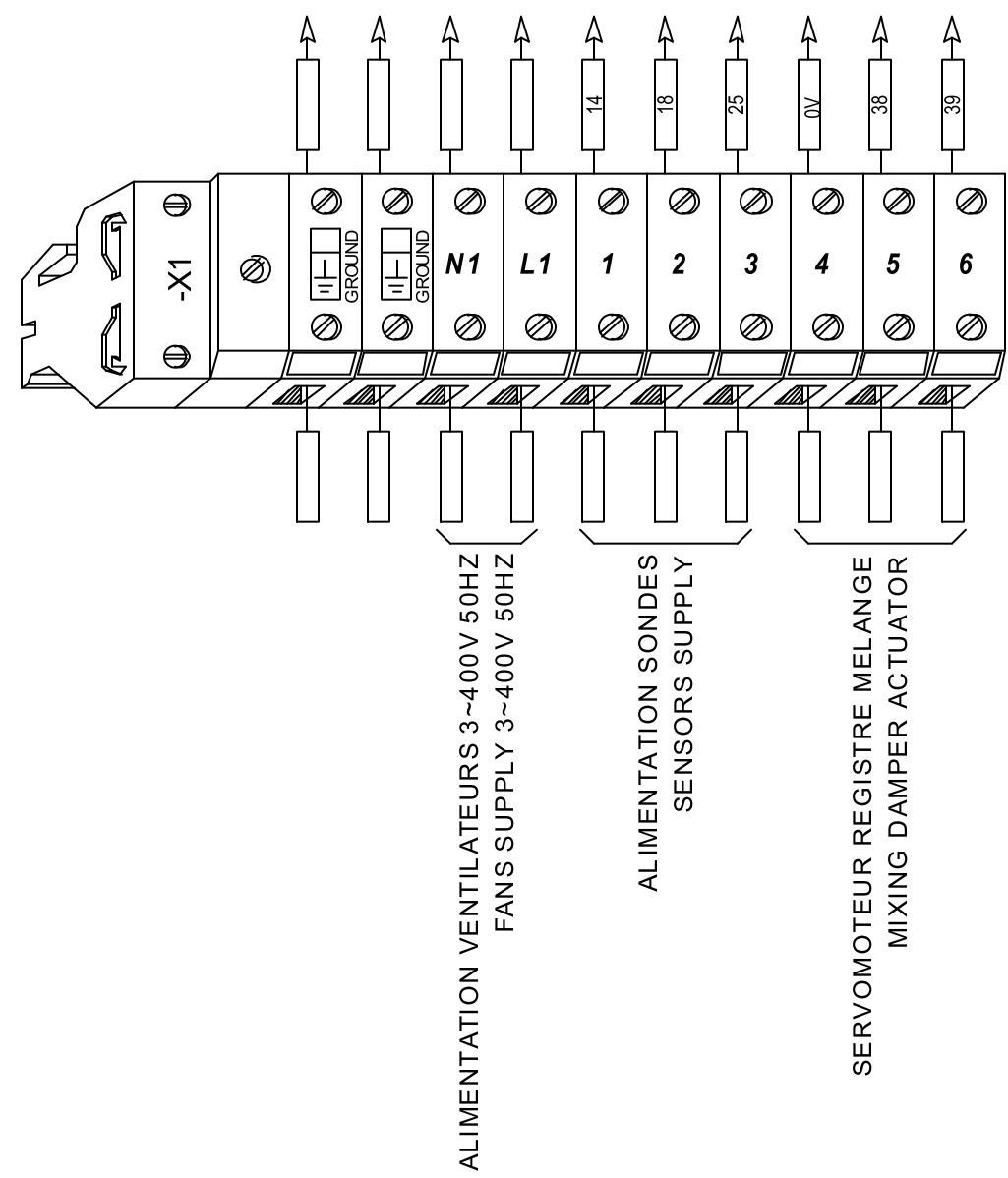

ARM

DESIGNATION :
DESIGNATION :



BORNIER : X1
TERMINAL : X1

NUMERO DE SCHEMA
DIAGRAM NUMBER
7590350

INDICE
INDEX
00

FOLIO
FOLIO
6/8

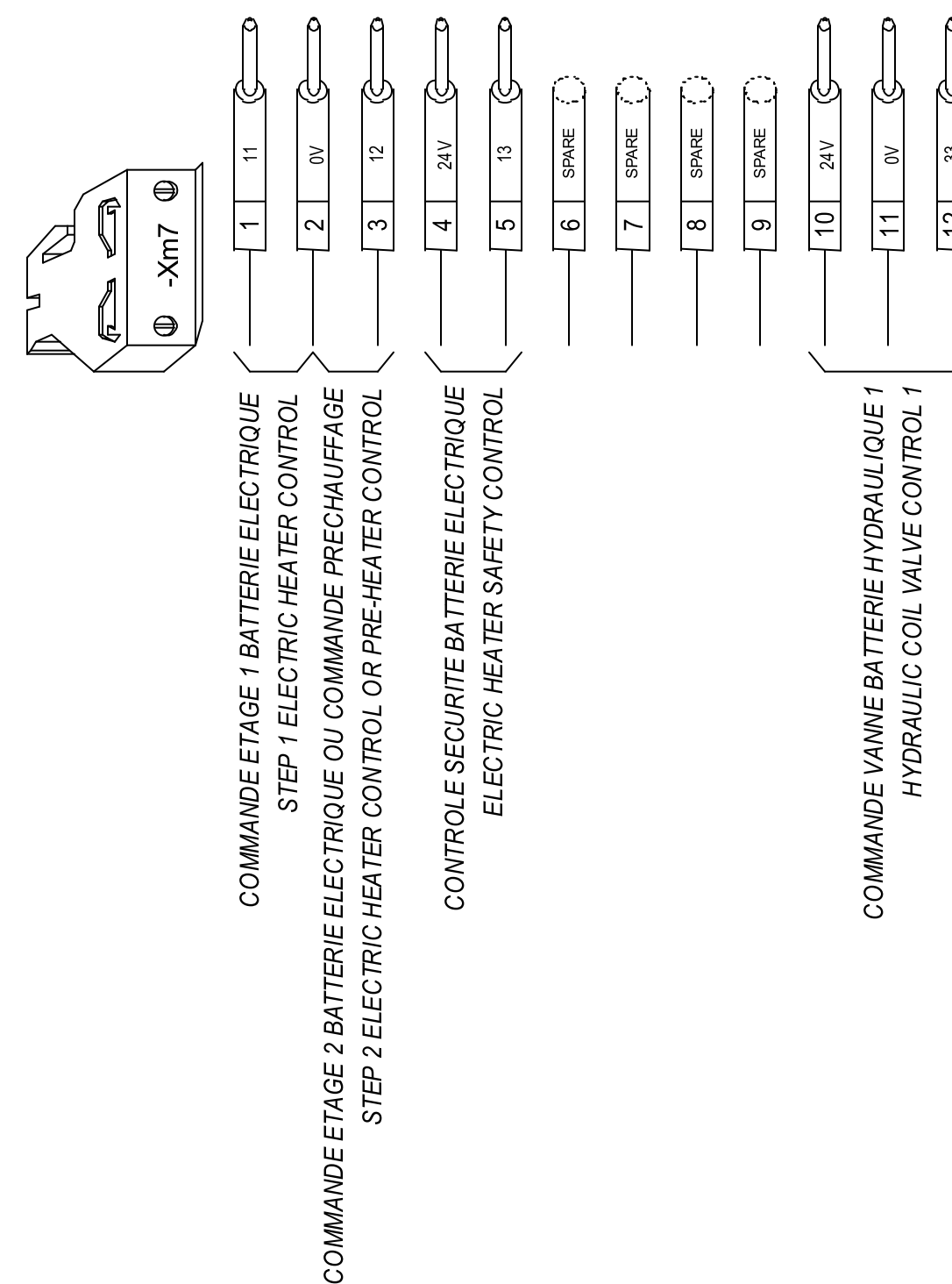
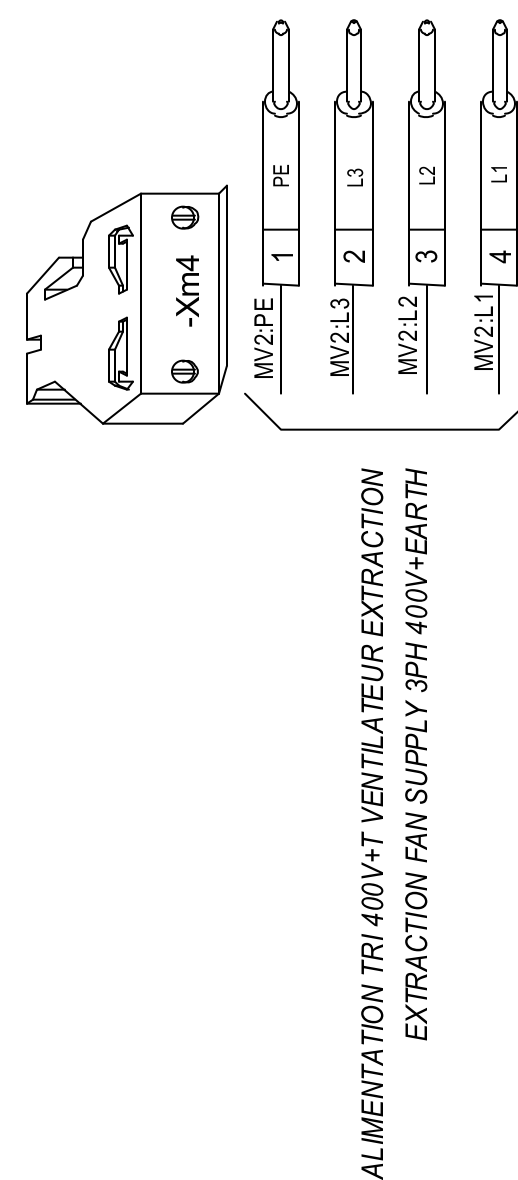
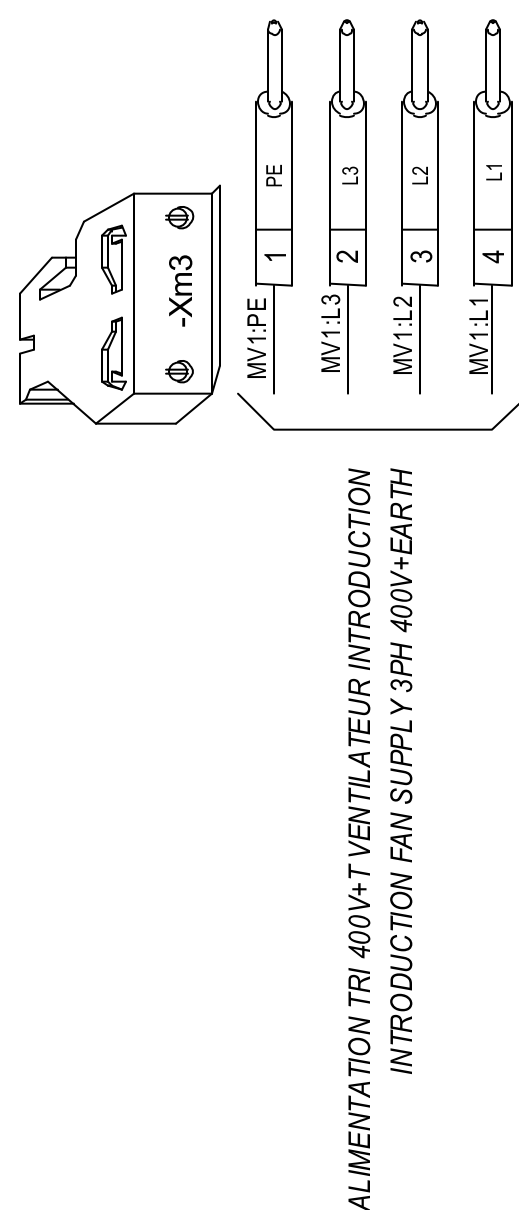
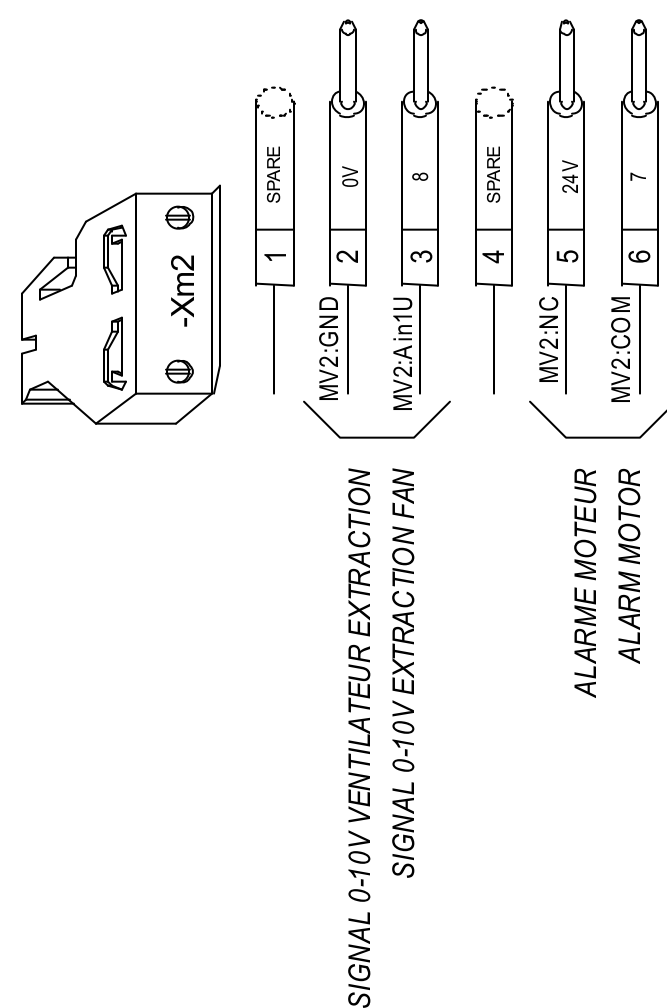
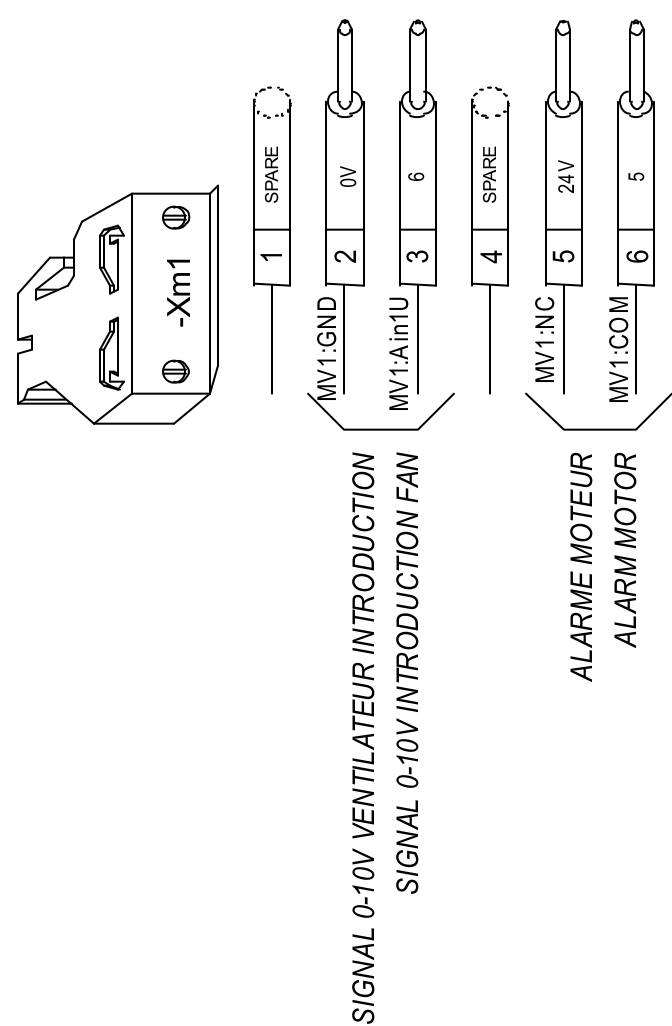

ARM

DESIGNATION :
DESIGNATION :



CONNECTEURS : Xm1, 2, 3, 4 et 7
CONNECTORS : Xm1, 2, 3, 4 and 7

NUMERO DE SCHEMA
DIAGRAM NUMBER

7590350

INDICE
INDEX

00

FOLIO
FOLIO

7/8

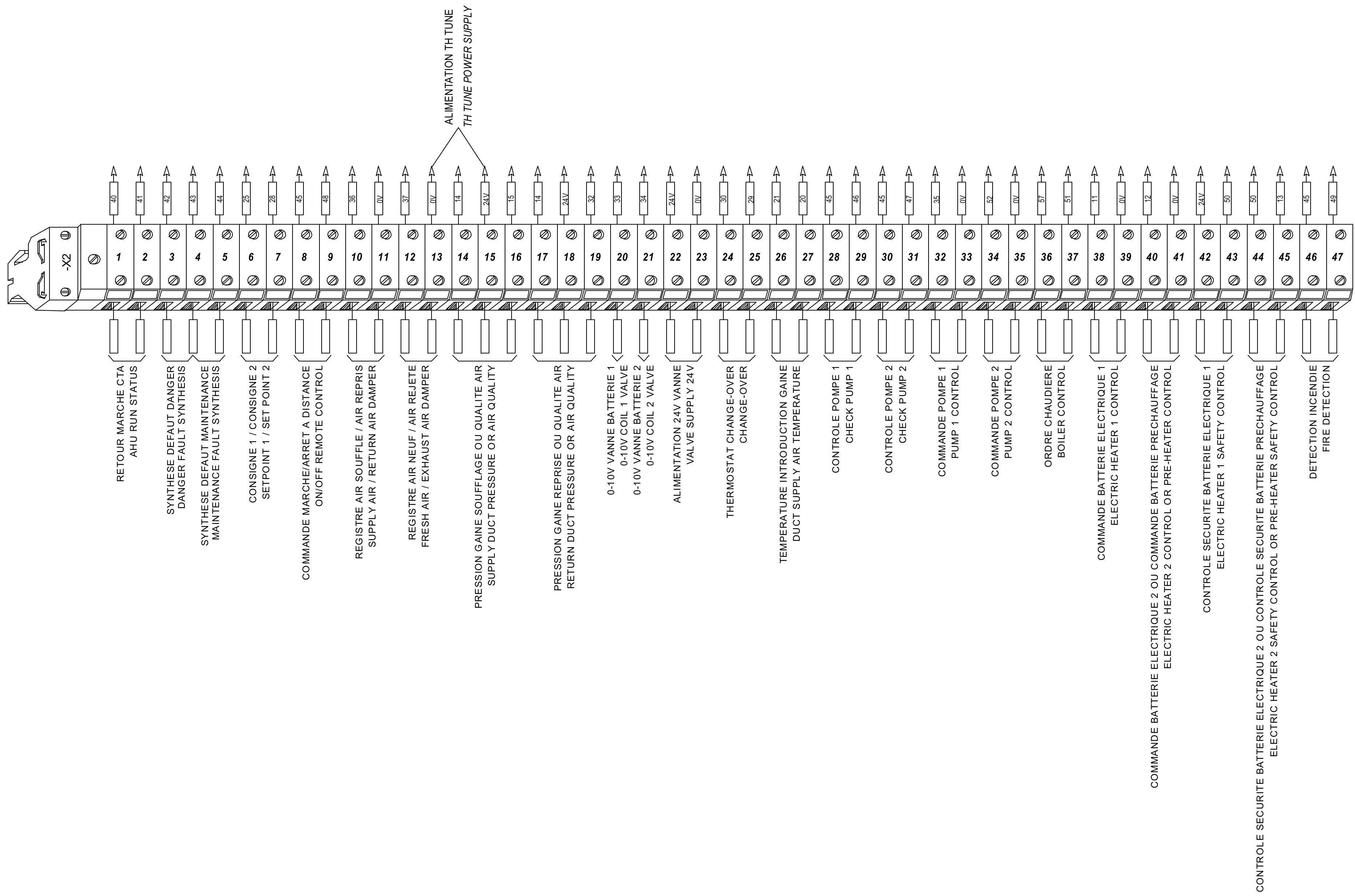

ARM

DESIGNATION :
DESIGNATION :



BORNIER : X2 (OPTIONS CLIENT)
TERMINAL : X2 (CUSTOMER OPTIONS)

NUMERO DE SCHEMA
DIAGRAM NUMBER
7590350

INDICE
INDEX
00

FOLIO
FOLIO
8/8