



Control manual

HomeConnect

NA 10.89 D

09 - 2013



CONTENTS	PAGE
1 FOREWORD	4
2 SAFETY INSTRUCTIONS	4
3 OVERVIEW OF THE CONTROL TERMINAL	5
3.1 The control terminal	5
3.2 Overview of the terminal	8
4 TERMINAL SETTING MENU	12
5 OPERATING MODE MENU	13
5.1 Structure of the menu	13
5.2 Setting the operating modes	15
5.3 Weekly programming	18
6 INFORMATION	21
6.1 Measured values	21
6.2 Consumption	21
7 REMOTE CONTROL	22
7.1 DHW production by external contact	22
7.2 Forced cooling or heating mode by external contact	22
7.3 Absence mode requested by the external contact	22
8 DIAGNOSTICS	22
8.1 Information and alarm	22
8.2 Resetting alarms	23
9 FAQ (Frequently Asked Questions)	23
9.1 Changing batteries	23
9.2 The temperature varies	23
9.3 The operating setpoints for the heat pump	23
9.4 The radio signal	24
10 APPLICABLE STANDARDS AND CLEANING THE PRODUCT	24
10.1 Standards and directives	24
10.2 Temperature, humidity	24
10.3 Cleaning the product	25
11 WEEE SYMBOL (Waste Electronic and Electrical Equipment)	25

The  symbol denotes important information throughout this document.

 **Read the operating instructions before use and keep them in a safe place.**

1 FOREWORD

Thank you for choosing CIAT. We are confident that you will be completely satisfied with the heat pump that you have just purchased, for many years to come. All CIAT products are designed to optimise performance and to provide our customers with guaranteed comfort and energy savings.

This manual will help you to use the HomeConnect control terminal to ensure that you get the best out of your heat pump. This document will guide you in the unit's simple programming and routine maintenance operations.

With a view to continually improving this product, CIAT reserves the right to modify this manual at any time.

It should be noted that this manual is common to all CIAT products fitted with a HomeConnect control. Consequently, some functions may not be applicable to all configurations.

2 SAFETY INSTRUCTIONS

- Keep out of the reach of children.
- Do not attempt to repair this unit yourself.
- Do not attempt to open the terminal.
- In the event of suspicious odour, abnormal noise or emission of smoke, switch your unit off and contact your installer.
- Never use solvents to clean the control terminal.
- Do not place the terminal near to a source of heat and avoid direct exposure to sunlight.
- Do not place the control terminal in a metal box.
- This equipment must only be used indoors.
- **Warning:** there is a risk of explosion if the batteries are replaced with batteries of the wrong type. Dispose of used batteries in accordance with legal requirements and replace them with those recommended in section 3.1.

3 OVERVIEW OF THE CONTROL TERMINAL

3.1 The HomeConnect control terminal



The control terminal is supplied with:

- 3 LR6 type AA batteries, each 1.5 V (fitted in the battery compartment)
- A base
- A wall bracket

The device is switched off by removing one or more of the three batteries. Switching the device off does not stop the heat pump.

Technical characteristics of the product:

- Supply voltage: between 2.9 V and 4.8 V supplied by 3 LR6 batteries
- Average current drawn: 300 μ A
- Maximum consumption: 140 mA
- Weight: terminal = 259 g, base = 35 g and wall bracket - 17 g
- Dimensions: width: 9 cm, height: 14 cm, thickness: 2.5 cm
- Range of 3m through 2 walls



The plastic tab must be removed from the battery compartment in order to power on the terminal.

To change the terminal batteries, turn the terminal over and proceed as follows:

- 1 Remove the terminal from its support (base or wall bracket)



- 2 Push the battery cover to gain access to the batteries



- 3 Take the batteries out and replace them



- 4 Check the batteries are correctly oriented and positioned

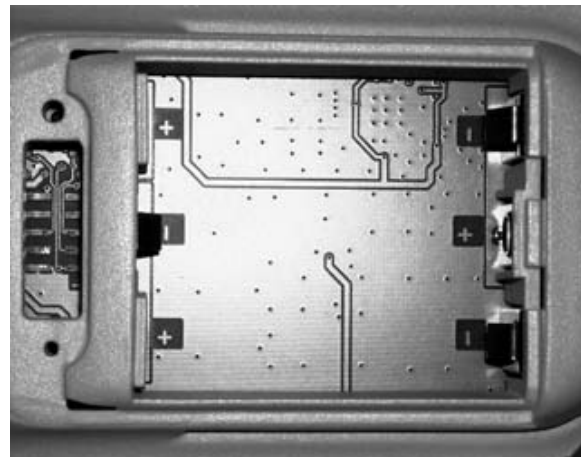

IMPORTANT for Switzerland: Annex 4.10 to the norm SR 814.013 is applicable to batteries.

Installing the HomeConnect terminal

The HomeConnect terminal can be installed on a flat surface or against a wall.

To install it on a flat surface, insert the base as shown below. To install it on the wall bracket, you need suitable screws (see description below).

EN

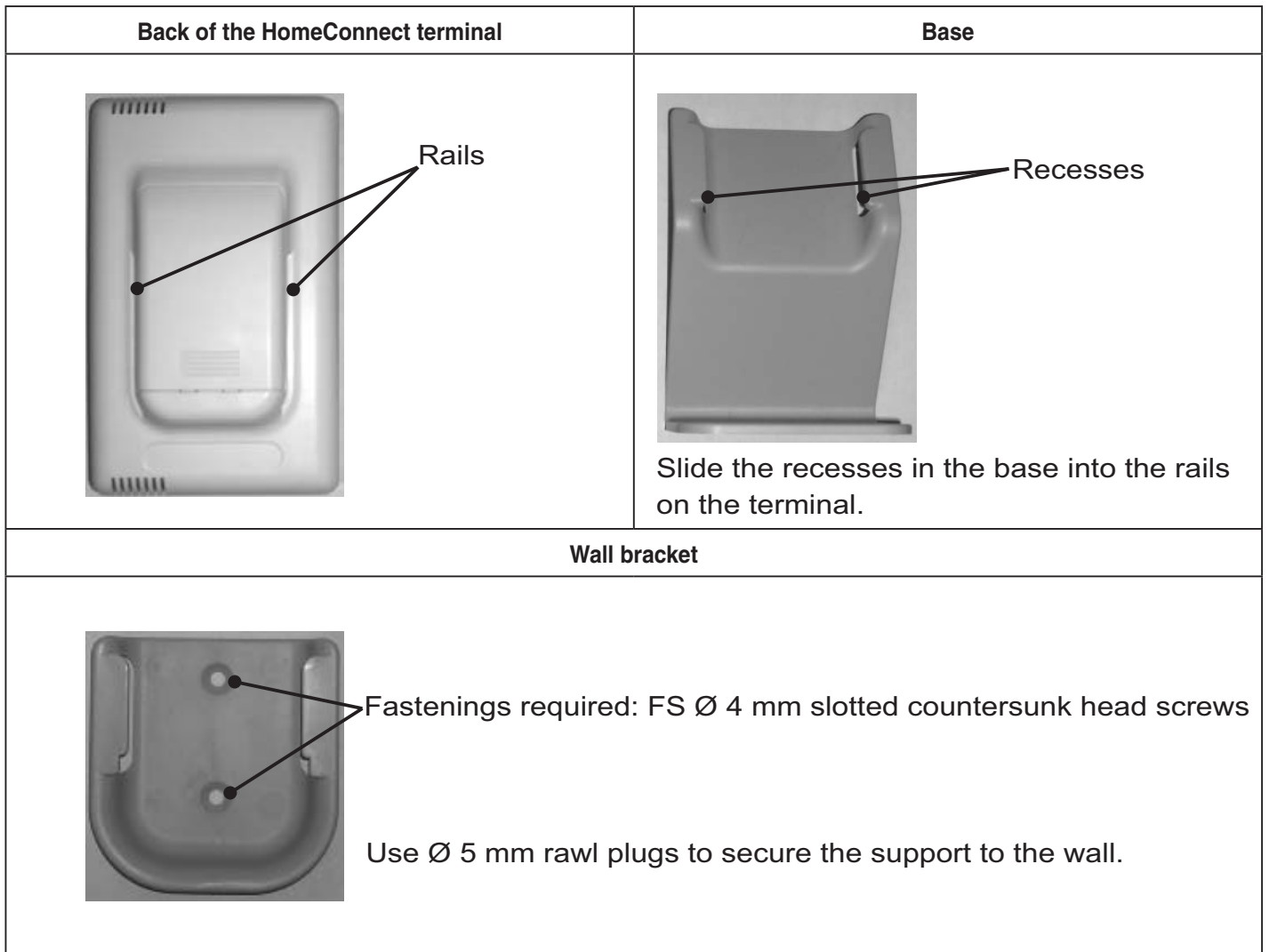

Installation in the ambient zone to be controlled

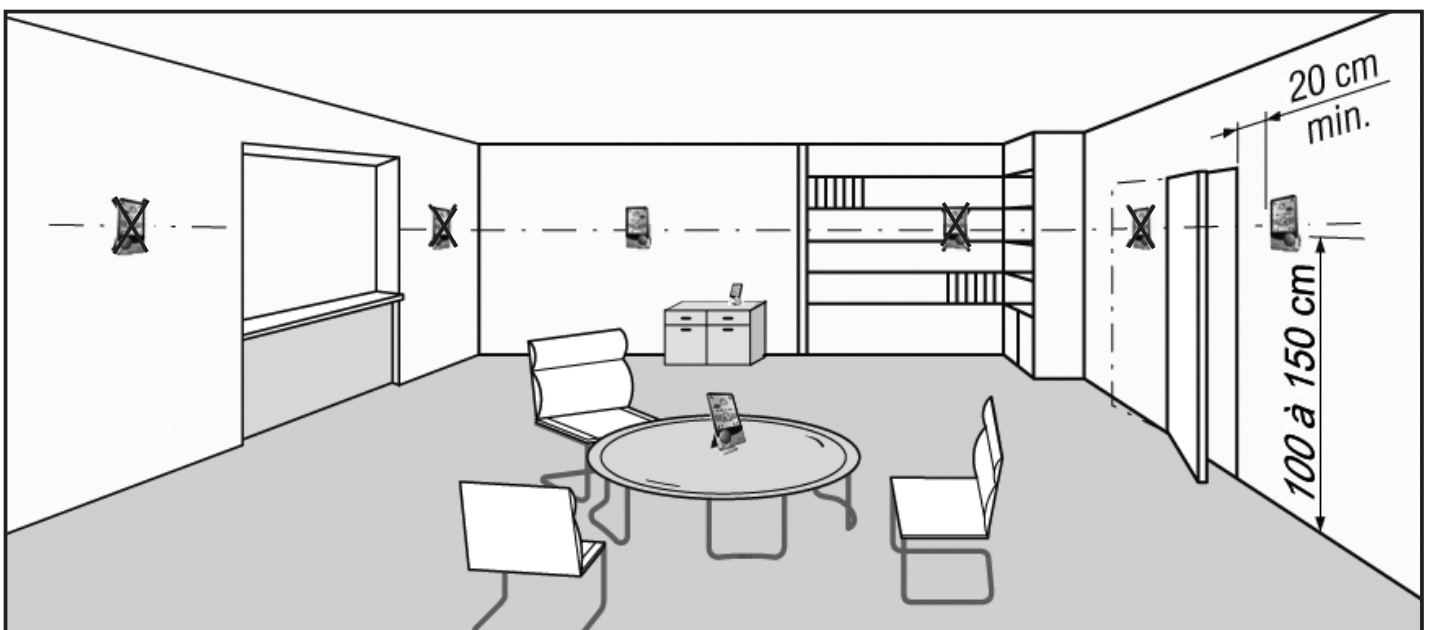

3.2 Overview of the terminal

3.2.1 Graphic display

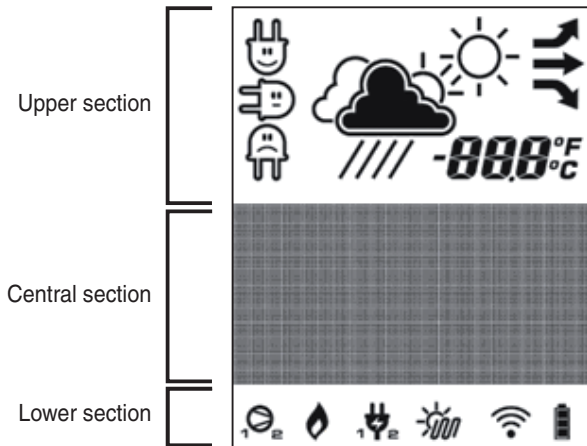

Example display:

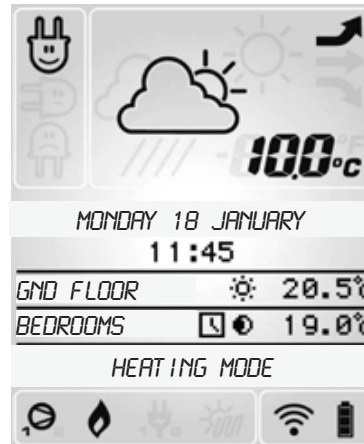

UPPER SECTION

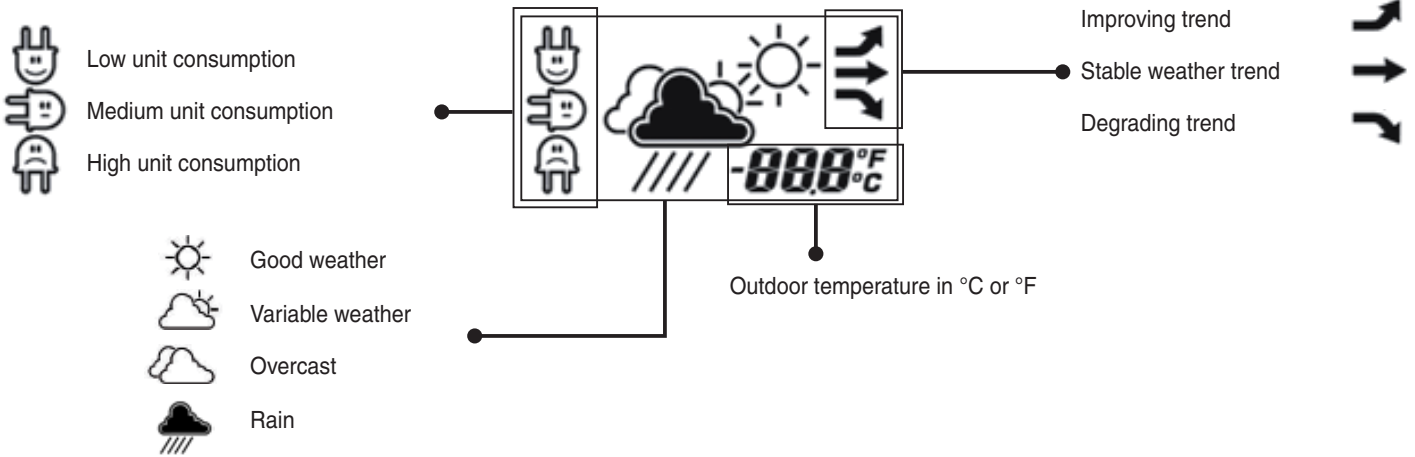

LOWER SECTION

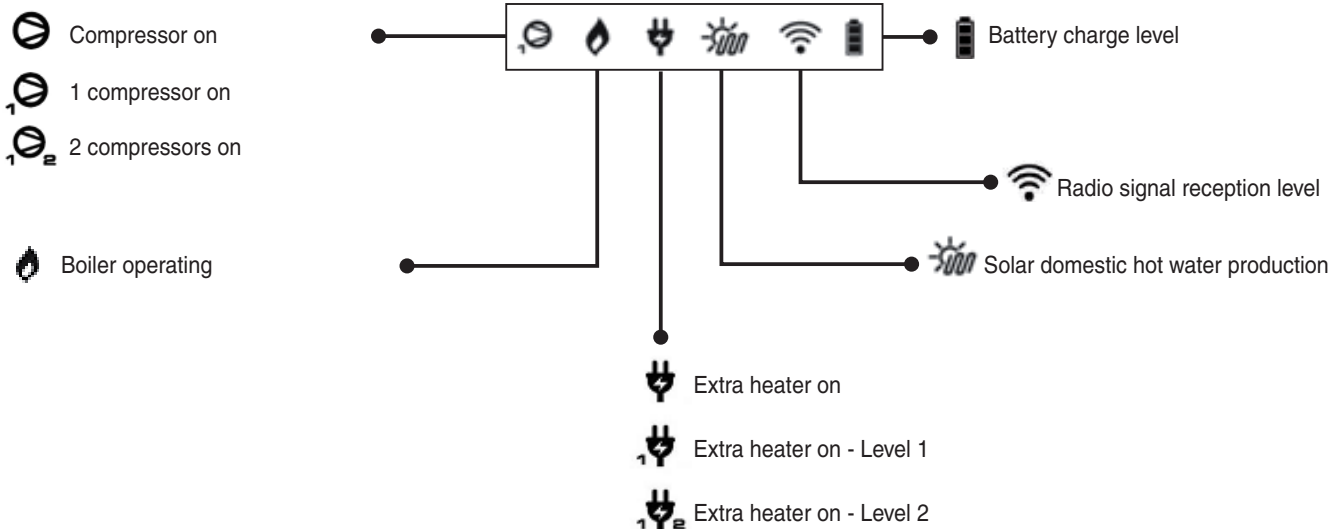



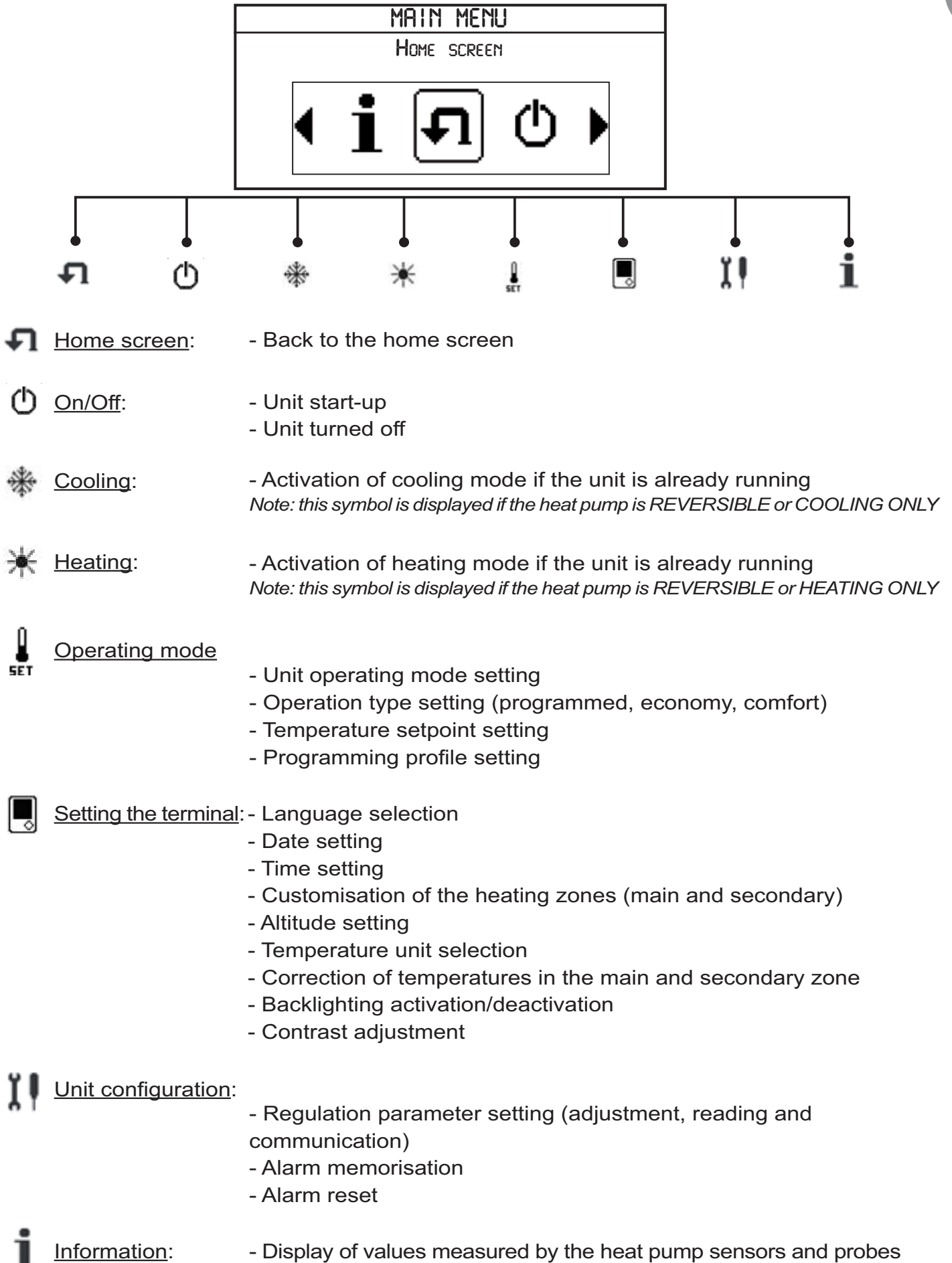

The MAIN MENU is accessed by pressing the turn and click dial on the home screen.



3.2.2 Navigation

A single dial is used to navigate within the control terminal.

The dial can be used to carry out the following actions:

<p>Clockwise rotation</p> 	<ul style="list-style-type: none"> - navigate within the various menus in the graphic interface - increase, decrease or edit the value for a parameter
<p>Anticlockwise rotation</p> 	<ul style="list-style-type: none"> - switch from one time period to another in the daily programming of cooling mode, heating mode and the domestic hot water production
<p>Quick press (one click)</p> 	<ul style="list-style-type: none"> - access the main menu from the home screen - confirm a new setting - select or deselect the days of the week in the weekly programming - select the operating level for daily programming of cooling mode and heating mode
<p>Press and hold for 3 seconds</p> 	<ul style="list-style-type: none"> - access quick edit for the type of control and the heating and cooling mode setpoint, from the home screen, if one of these 2 modes is activated on the control terminal (see section 3.2.4) - activate forced mode (programmed mode overridden) (see section 5.3.1)
<p>Press and hold for 5 seconds</p> 	<ul style="list-style-type: none"> - reset the operating time counters to zero (see section 6.2.1)

3.2.3 Navigation example

Below you will find an example of how to navigate from the main display to shut down the machine when it is running.

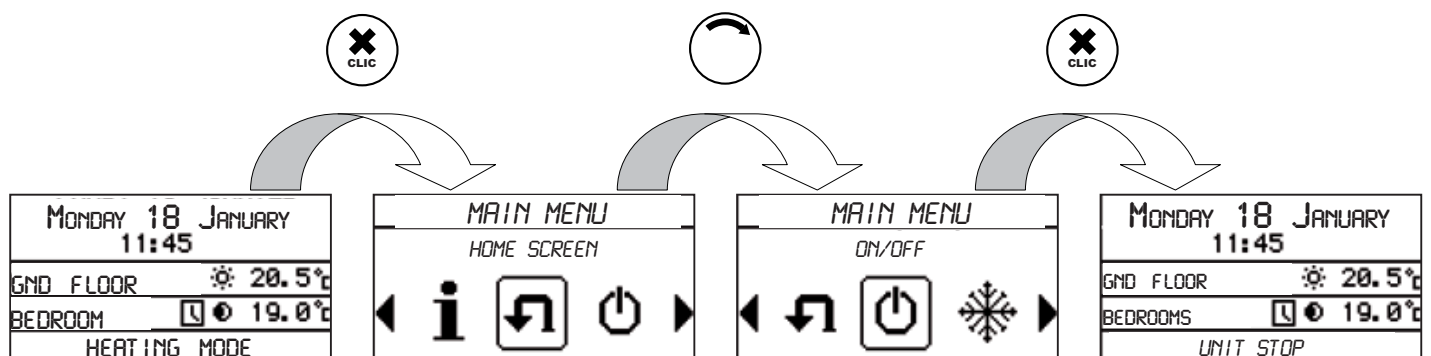



3.2.4 Quick edit for the type of control and the setpoint

To quickly edit the type of control and/or the setpoint for the current mode, press the button for 3 seconds, from the home screen.

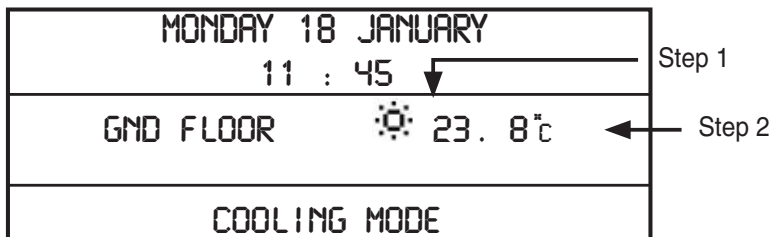

→ **Step 1:** select the operation type (the symbol flashes)

Rotate or to select the new operation type then confirm with

Heating mode active	Cooling mode active	Operation type
		Comfort operation
		Economy operation
		Programmed operation

→ **Step 2:** set the temperature setpoint corresponding to the operation type for "gnd floor" (zone 1)

The room temperature display for "gnd floor" is replaced with the flashing display for the current setpoint.

Turn the dial to increase or to decrease the temperature setpoint value in increments of 0.5°C (or in increments of 1°F).

Confirm the temperature setpoint with . The room temperature for "gnd floor" reappears.

4 TERMINAL SETTING MENU

The Terminal setting menu allows each user to adjust the setup parameters for his or her terminal.

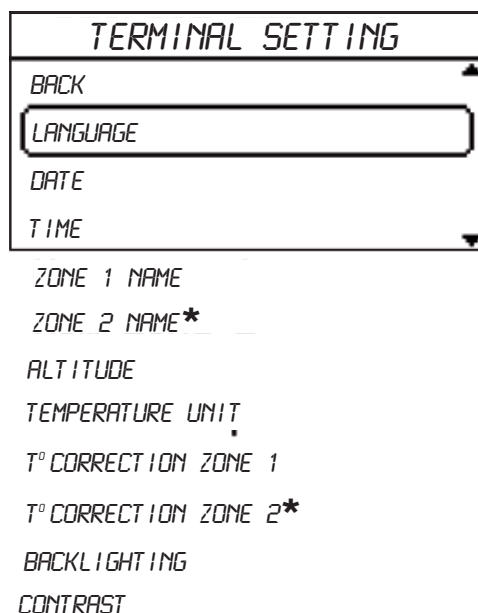

Menu	Sub-menus	Setting range	Description	Factory values	
Setting the terminal 	Back		Back to the previous state		
	Language	FRENCH	10 characters XXXXXXXXXX	Language selection	FRENCH
		ENGLISH			
		DEUTSCH			
		ESPANOL			
		ITALIANO			
		NEDERLANDS			
	Date	DD-MM-YYYY	Date setting DD-MM-YYYY	01-01-2010	
	Time	hh:mm	Used to set the time hh:mm	00:00	
	Zone1 name	10 characters XXXXXXXXXX	Set the name for zone 1	gnd floor	
	Zone 2 name *		Set the name for zone 2	bedrooms	
	Altitude	0 to 2000m	Set the altitude at which the heat pump is installed	0	
	Temperature unit	Celsius	Temperature display selection	Celsius	
		Fahrenheit			
	T° correction zone1	-5.0°C to +5.0°C	Correction of the zone 1 ambient temperature	0.0°C	
T° correction zone2*	-5.0°C to +5.0°C	Correction of the zone 2 ambient temperature	0.0°C		
Backlighting	YES/NO	Backlighting activation/deactivation	YES		
Contrast	0 to 10	Adjust the display contrast	5		









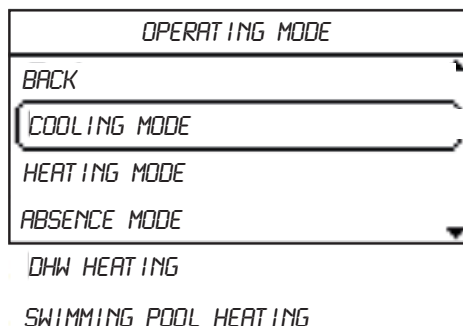











* only if two zones have been declared when the heat pump is installed by your installer.
If the temperature unit is Fahrenheit, the ambient temperature correction range is -9 to 9°F (in increments of 0.2).







5 OPERATING MODE MENU

5.1 Structure of the menu

The Operating mode menu is used to configure the heat pump operating mode once it has been started up using the  icon.



Menus	Sub-menus	Setting range	Factory values ***	Description	
Cooling mode	Back	-	-	Back to the previous state	
	Gnd floor* operation	ECO 	-	-	Gnd floor operation in cooling mode with economy setpoint
		COMFORT 		✓	Gnd floor operation in cooling mode with comfort setpoint
		PROG 		-	Gnd floor operation in cooling mode with weekly programming
		BACK		-	Back to the previous state
	Gnd floor  setpt*	18 to 30°C	22°C	Increase or decrease the comfort setpoint in cooling mode for the gnd floor	
	Gnd floor  setpt*	22 to 30°C	25°C	Increase or decrease the economy setpoint in cooling mode for the gnd floor	
	Gnd floor  prog*	Weekly programming on 3 levels (STOP/  / )		Programming of the operating hours for the unit in cooling mode on the gnd floor stop, comfort or economy setpoint	
Heating mode	Back	-	-	Back to the previous state	
	Gnd floor* operation	ECO 	-	-	Gnd floor operation in heating mode with economy setpoint
		COMFORT 		✓	Gnd floor operation in heating mode with comfort setpoint
		PROG 		-	Gnd floor operation in heating mode with weekly programming
		BACK		-	Back to the previous state
	Gnd floor  setpt*	15 to 30°C	21°C	Increase or decrease the comfort setpoint in heating mode for the gnd floor	
	Gnd floor  setpt*	15 to 21°C	19°C	Increase or decrease the economy setpoint in heating mode for the gnd floor	
	Gnd floor  setpt*	8 to 15°C	10°C	Increase or decrease the absence (frost protection) setpoint for the gnd floor	
Gnd floor  prog*	Weekly programming on 3 levels ( /  / )		Programming of the operating hours for the unit in heating mode on the gnd floor stop, comfort, economy or absence setpoint		

Menus	Sub-menus	Setting range	Factory values	Description	
Absence mode	Back			Back to the previous state	
	Absence operation	IMMEDIATE 		Switches the unit to absence operation immediately	
		PROG 		Programmed operation of the unit in absence mode	
		CANCEL		Stops absence mode if running Returns to the operating mode in use before the unit was switched to absence mode	
		BACK		Back to the previous state	
	Gnd floor  setpt*	8 to 15°C	10°C	Increase or decrease the absence setpoint for the gnd floor	
	Prog 	DD/MM/YYYY		Programming of the departure and return date	
	DHW option	YES	NO	Authorisation of DHW heating in absence mode according to the DHW cycle 1 and 2 programming	
		NO		No DHW heating in absence mode	
		PREPROGRAM		DHW heating one day before the end of the programmed absence	
DHW heating** (option)	Back	-	-	Back to the previous state	
	Boost	-	-	Forced restart of a DHW heating cycle	
	DHW operation	ONLY			Unit operating in DHW heating mode only
		PRIORITY			DHW heating as a priority over heating
		PROG		-	Programmed DHW heating (1 or 2 daily cycles)
		EXTERNAL		-	DHW heating governed by external contact
		STOP		-	DHW heating stopped independently of the modes
		BACK		-	Back to the previous state
	DHW setpoint	40 to 70°C	55°C	Increase or decrease of the DHW setpoint	
	Daily cycle	1		-	1 daily DHW heating cycle in PROG operation
		2		-	2 daily DHW heating cycles in PROG operation
	Prog  cycle 1	Weekly programming for cycle 1		-	Customisation of the daily production of DHW for cycle 1 and setting the start of the cycle
	Prog  cycle 2	Weekly programming for cycle 2		-	Customisation of the daily production of DHW for cycle 2 and setting the start of the cycle
	Unit stop	WITH DHW		-	Production of DHW maintained during a stop request
		WITHOUT DHW		-	Production of DHW stopped during a stop request
Swimming pool heating (option)	Back	-	-	Back to the previous state	
	Pool operation	ONLY		-	Unit operating with pool heating only
		COUPLED			Pool heating combined with cooling or heating
		STOP		-	Pool heating stopped
		BACK		-	Back to the previous state
Pool setpoint	20 to 35°C	28°C	Increase or decrease of the pool setpoint		

Warning: please be aware that only reversible units or cooling only units can run in cooling mode.

* The zone 1, defined by default with the value "gnd floor", can be extended to zone 2, defined as "bedrooms"

** DHW: domestic hot water

*** The default values are defined for a UHCS Underfloor Heating and Cooling System on the ground floor

Setpt = temperature setpoint

Info: 1°C = 33.8°F

5.2 Setting the operating modes

5.2.1 Setpoint and control for cooling mode

(only for cooling only or reversible units)

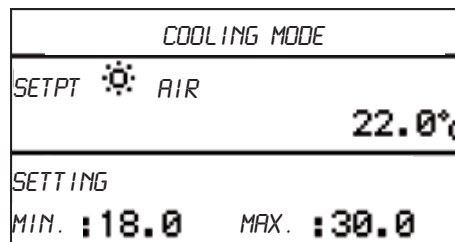
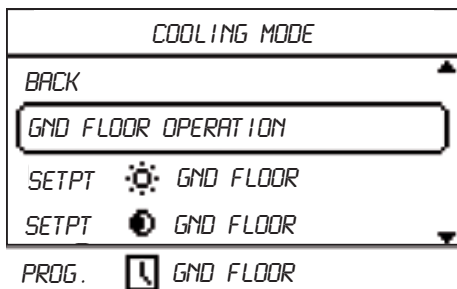

➔ COOLING MODE terminal display.

Examples of setpoint ranges for the COMFORT ☀ setting

Cooling floor	Fan coil units	
Setting range or the setpoint ☀ air: 18 to 30°C	No indoor environment compensation * (set by your installer)	Water ☀ setpt: 10 to 28°C
	With indoor environment compensation * (set by your installer)	Air ☀ setpt: 18 to 30°C

* in cooling mode, the indoor environment compensation is used to activate control of the heat pump using an air temperature setpoint. This parameter is selected by the installer when the heat pump is started up.

5.2.2 Setpoint and control for heating mode

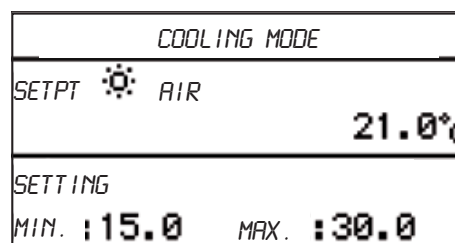
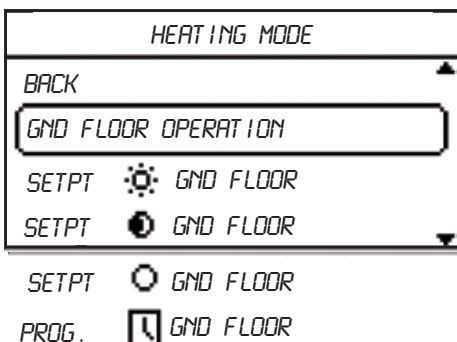

➔ HEATING MODE terminal display.

Examples of setpoint ranges for the COMFORT ☀ setting

Underfloor heating system, radiators or fan coil units	
No indoor environment compensation * (set by your installer)	Water ☀ setpt: 20 to 40°C (underfloor heating system) 20 to 55°C (fan coil units or radiators)
With indoor environment compensation * (set by your installer)	Air ☀ setpt: 15 to 30°C

*in heating mode, the indoor environment compensation is used to correct the difference between the measured room temperature and the air temperature setpoint. This parameter is selected by the installer when the heat pump is started up

5.2.3 Setpoint and control for absence mode

On the control terminal, it is possible to activate management of absence mode in 2 different ways: .

- IMMEDIATE: departure from the residence is immediate
- PROG: the departure from and return to the residence are planned and programmed

To cancel absence mode:

- CANCEL: upon return to the residence, CANCEL can be selected to return to the choice selected before ABSENCE mode.

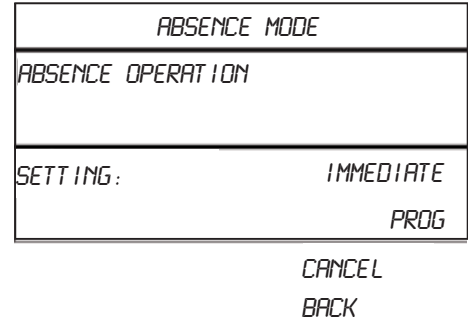
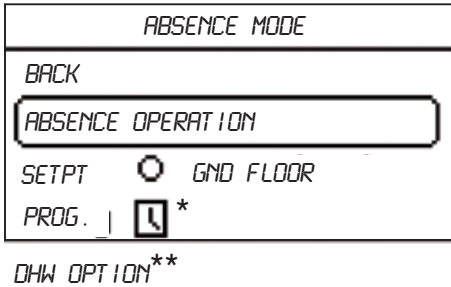

* Only visible if Absence operation = PROG

** Only visible if the production of DHW is authorised (option)

➔ ABSENCE MODE terminal display.

5.2.3.1 Setpoint and control for Absence mode

Absence mode is used to maintain a "frost-free" room temperature when the residence is unoccupied.

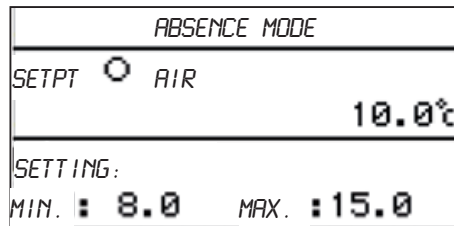

5.2.3.2 IMMEDIATE absence and production of DHW (DHW optional)

IMMEDIATE absence principle

➔ This operating mode corresponds to an immediate absence for an **undetermined period**. Managing the production of DHW (depending on the DHW option value: YES/NO)

Flow chart for the DHW option in IMMEDIATE absence operation:

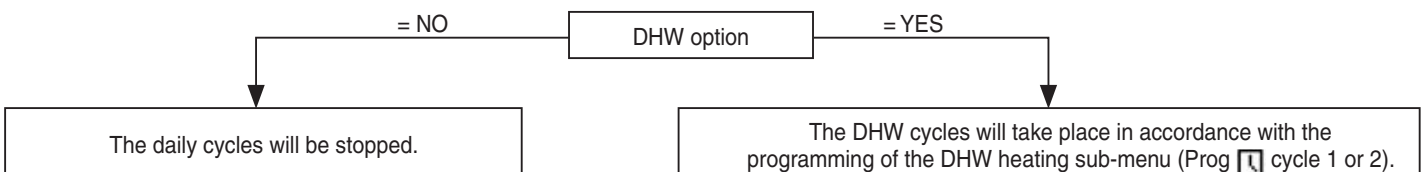

5.2.3.3 PROG absence and production of DHW (DHW optional)

PROG absence principle

→ This operating mode corresponds to a programmed absence for a **determined period**. (See section 5.3.2.3 for an example of programming)

Managing the production of DHW (depending on the DHW option value: YES/NO/PREPROGRAM).

You have the option to preprogram domestic hot water production for your return. Simply position the option on "PREPROGRAM".

Flow chart for the DHW option in PROG operation:

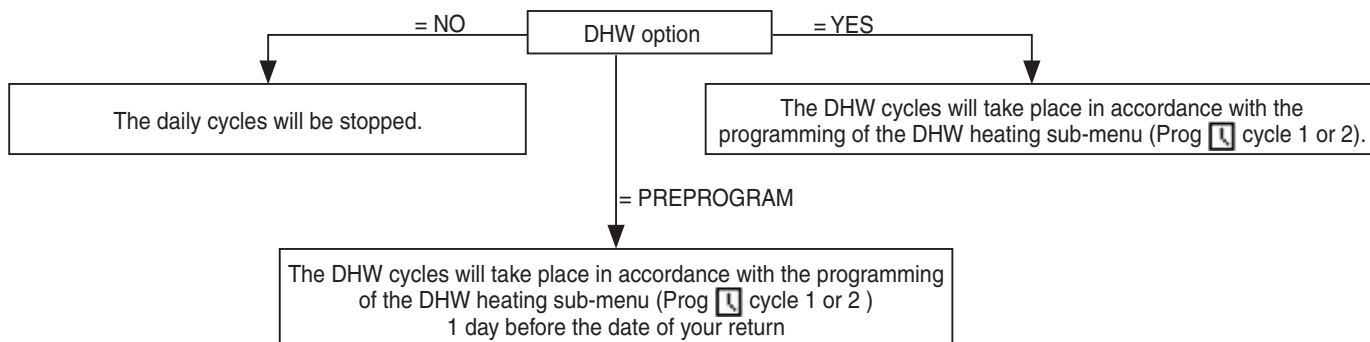

5.2.4 Setpoint and control for Pool heating mode (option)

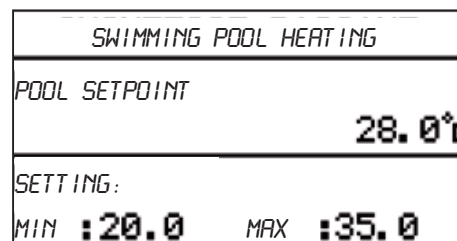
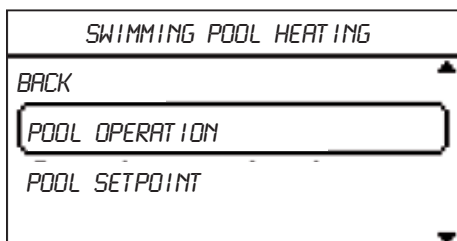

→ POOL HEATING terminal display.

Your heat pump can only heat your pool if the outdoor temperature > 5°C AND the pool water temperature > 10°C.

5.2.5 Setpoint for DHW production (option)

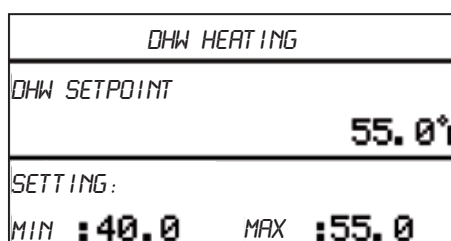
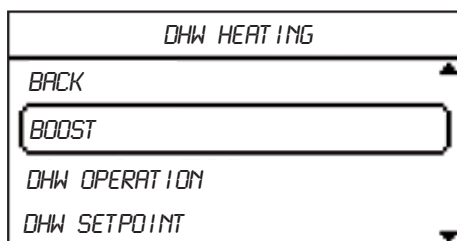





DAILY CYCLE
 PROG [] CYCLE 1
 PROG [] CYCLE 2
 UNIT STOP

→ Display on the terminal of the DHW HEATING period.

5.3 Weekly programming

5.3.1 The operating states in programming mode

Symbols for operation displayed in the home screen	
	Programmed stop of the heat pump (cooling mode)
	Programmed operation of the heat pump using a frost protection setpoint (heating or absence mode)
	Programmed operation of the heat pump using an economy setpoint (heating or cooling mode)
	Programmed operation of the heat pump using a comfort setpoint (heating or cooling mode)

Forced programmed mode











As part of the weekly programming, override () is used to "take over" the current setting, which means, for example, that another temperature setpoint can be made to override the one programmed. This new data will be effective until the parameter is changed once more.





To access this function, the heat pump must be in the following state:

- heating or cooling mode active
- programmed operation (PROG)
- activation of quick edit from the home screen (press and hold the button for 3 seconds ).

Rotate the dial to obtain a different type of operation:

Example of display in the home screen after validation of level 3 override in zone 1 gnd floor

	Heating mode active	Cooling mode active	Control mode
			Economy operation
			Comfort operation
			Programmed operation
	-	 	Level 1 Override (Stop)
		 	Level 2 Override (Economy)
		 	Level 3 Override (Comfort)



MONDAY 18 JANUARY	
11:45	
GND FLOOR	  23.8°C
BEDROOMS	  24.2°C
HEATING MODE	

Override mode is effective during the setting range for the time schedule when the operating level remains fixed. This means that if the unit's operating level is edited by the programming (for example, switching from level 3 to level 2), then the overridden programmed mode is cancelled and the unit runs again with the programming configured by the user.

5.3.2 Weekly programming example and principle

5.3.2.1 Heating/cooling

Principle: Weekly programming of heating and cooling mode on 3 levels

- Level 1: running on Setpoint  (frost-free) if heating mode or unit stop (STOP) if cooling mode
- Level 2: running on Setpoint  (Eco)
- Level 3: running on Setpoint  (Comfort)

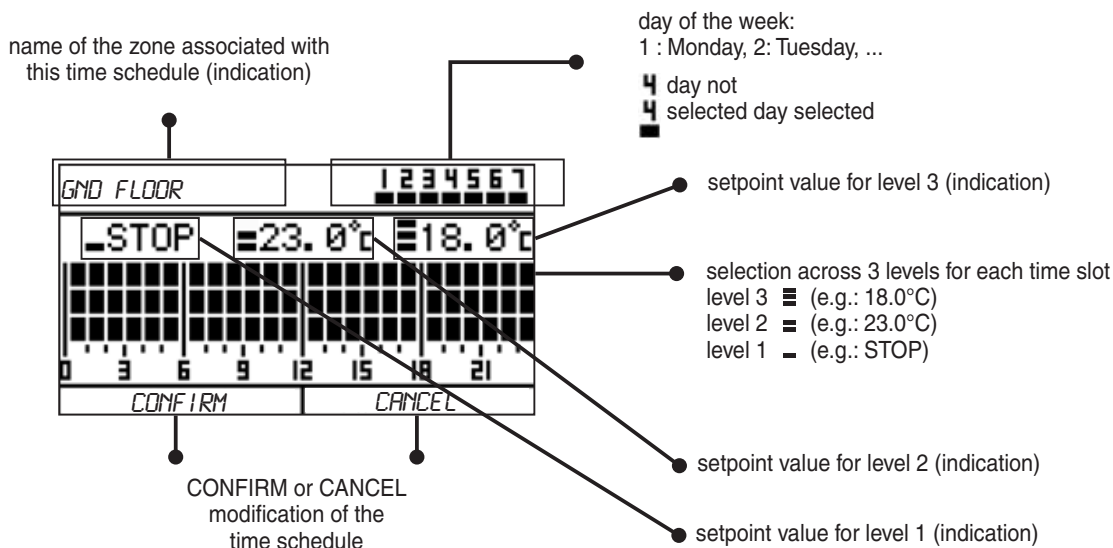



Example: Cooling mode → Prog  gnd floor

1- Press the button in the "Prog  gnd floor" sub-menu to bring up the programming screen:







- The "1" flashes in the days or the week zone (1 = Monday, 2 = Tuesday, etc)

2- Select the day of the week to be programmed  and press the  button to confirm.

3- Switch to day "7" then : the time slot 0-1h flashes



4- Select the time slots that you wish to program using  

5- Select the type of operation that you wish to apply to the time slot using the turn and click dial:

 Level 1 (STOP) –   Level 2 (Eco) –    Level 3 (Comfort)

6- When you reach the last time slot, turn the dial : "CONFIRM" flashes.

7- To confirm the week's programming, press the button .

To cancel the programming, turn the dial : "CANCEL" flashes. Press the button  to confirm you wish to cancel.

8 - Repeat steps 1 to 7 to program the other days of the week according to another temperature setpoint.

Note: If day 1 is flashing, rotate the dial anticlockwise  to select "CANCEL".



WARNING: If you wish to cancel without confirming, you will lose your weekly programming.

5.3.2.2 DHW heating (option)

Principle: Programming the DHW heating cycle start time

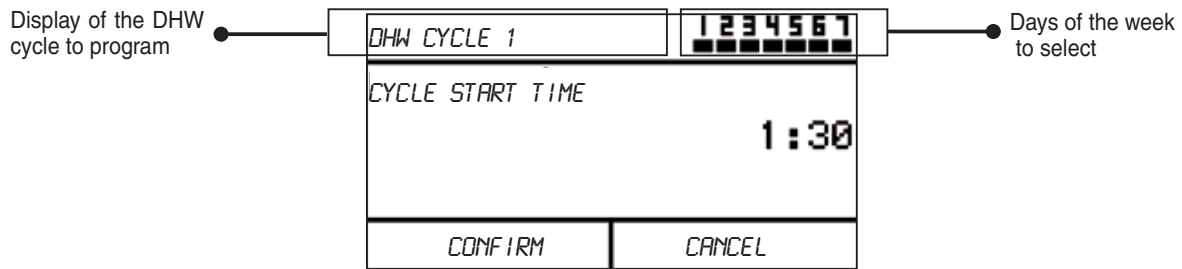

Note: same for cycle 2

Example: DHW heating → Prog cycle 1

1- Press the button in the "Prog cycle 1." sub-menu to bring up the programming screen:

The "1" flashes in the days of the week zone (1 = Monday, 2 = Tuesday, etc)

2- Select the days and confirm them by pressing the button

3- Select "Cycle start time" by turning the dial

4- Set the cycle start time by turning the dial (scrolls in increments of 30 minutes from 00:00 to 23:30) then confirm

To cancel, turn the dial : "CANCEL" flashes. Press to confirm you wish to cancel.

Note: If day 1 is flashing, rotate the dial anticlockwise to select "CANCEL".

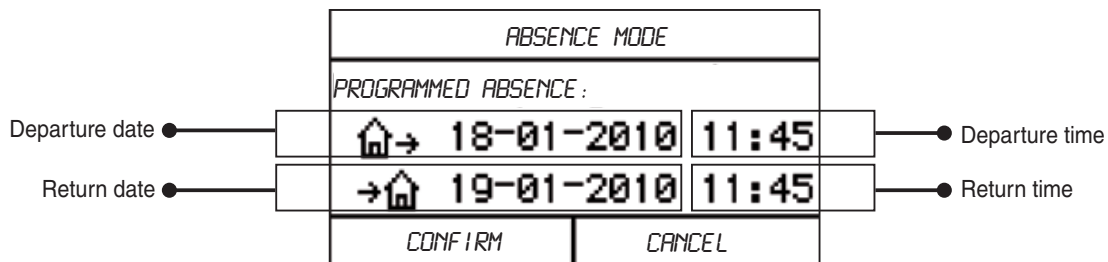

5.3.2.3 Absence

Principle: Programming the start and end of absence mode

Example: Absence mode → Prog

1- Press the button in the "Prog .

 sub-menu to bring up the programming screen. The start date "DD-MM-YYYY" (defaults to the current date) flashes.

2- Set the start date by turning the dial . Note: anticlockwise rotation stops at the current date

3- Confirm by pressing the button . The start time "hh:mm" flashes.

4- Set the start time by turning the dial (defaults to the current time).

5- Confirm by pressing the button . The return date "DD-MM-YYYY" flashes.

6- Set the return date by turning the dial (defaults to the departure date + 1 day) then confirm by pressing the button : the return time "hh:mm" flashes.

7- Set the return time by turning the dial confirm by pressing the button : "CONFIRM" flashes.

8- To confirm the programming, press the button . To cancel the programming, turn the dial :



"CANCEL" flashes. Press to confirm you wish to cancel.

6 INFORMATION **i**

6.1 Measured values

The measured values are data read by the sensors located on the unit (temperature sensors, pressure sensors, etc.) or on the terminal (room temperature sensor, etc.) to provide information on the environment.

The measured values are found in the Information menu **i**. Press the button on the display to access the Measured values sub-menu.

- ➔ Rotate the dial  to scroll through the lines in the measurement table.
- ➔ A single press on the  button takes you back to the previous level.

Example of measured values display:

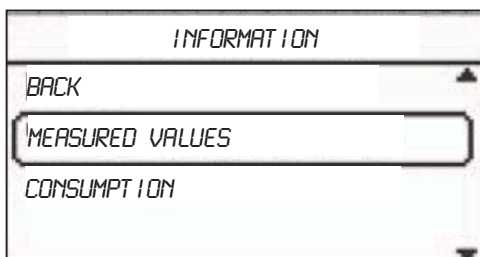

MEASURED VALUES	
EXTERNAL	3.6°C
AMBIENT	21.2°C
AMBIENT 	19.7°C
WATER SETPT	32.1°C

 Indicates that the room air temperature comes from zone 2 (option).

6.2 Consumption

The electrical and heat consumption of the machine can only be accessed on the latest generation of machines. This consumption menu gives access to:

- An instantaneous counter

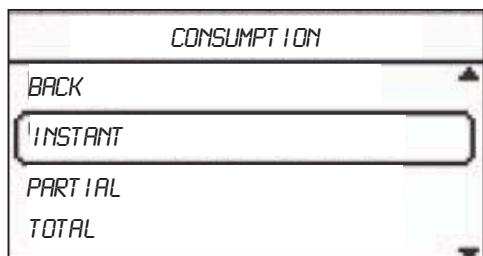

- Compressor electrical power
- Heating capacity
- Heat pump electrical power
- Auxiliaries electrical power

- A partial counter

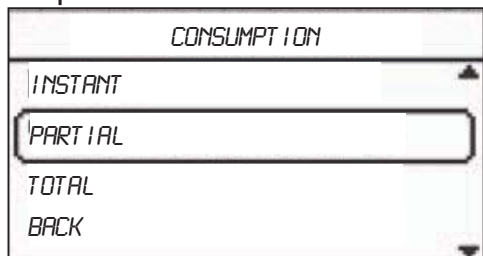

- Electrical energy consumption in heating mode
- Electrical energy consumption in domestic hot water mode
- Heat energy consumption
- Electrical energy consumption for the auxiliaries
- Electrical energy consumption for the heating elements

- A total counter

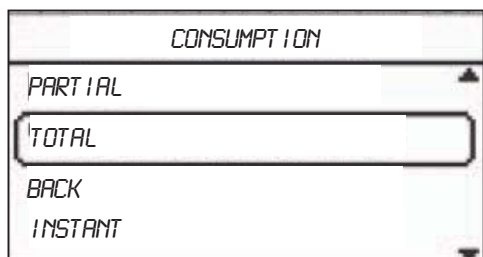

- Total electrical energy consumption in heating mode
- Total electrical energy consumption in domestic hot water mode
- Total heat energy consumption
- Total electrical energy consumption for the auxiliaries
- Total electrical energy consumption for the heating elements

Only partial consumption can be used to display consumption from a particular date. It can be reset by pressing the button for 5 seconds.

7 REMOTE CONTROL



The selection of the remote control is defined by your installer. Only one choice from the four shown below can be operational if remote control is authorised.

7.1 DHW production by external contact

Production of DHW is governed by the opening and closing of the external contact.

When the contact is closed, the DHW function is prioritised by your heat pump. Once the DHW cycle is complete, the heat pump's operating mode returns to the state it was in prior to this request.

7.2 Forced cooling or heating mode by external contact

The unit is forced to run in cooling mode or heating mode based on the opening/closing of the external contact.

For the two modes, the temperature setpoints applied are those configured in section 5.2.1 or 5.2.2.

7.3 Absence mode requested by the external contact

The unit is governed in absence mode by the closing of the external contact.

For this mode, the temperature setpoint applied is that configured in section 5.2.3.3.

8 DIAGNOSTICS

8.1 Information and alarm

There are 2 types of faults displayed on the home screen:

- **informative** message which does not disrupt operation of the unit.
- **alarm** fault causing the unit to shut down with mandatory resetting of the terminal once diagnostics has been carried out.

INFO		
INT SENSR BATTERY LOW		
GND FLOOR		23.8°C
BEDROOMS		24.2°C
COOLING MODE		

ALARM		
HP PRESSURE SWITCH		
GND FLOOR		23.8°C
BEDROOMS		24.2°C
COOLING MODE		

8.2 Resetting alarms

In the Unit configuration menu, the unit is reset after a fault by carrying out the following:

UNIT CONFIGURATION	
ALARM RESET	
SETTING:	NO

with the button, select "YES" to delete the alarm

1- To scroll through the "YES" or "NO" values in the setting field, turn the dial  .

2- Select "YES" then press  → Acknowledgement of the alarm if the cause of the fault has been resolved.

Select "NO" then press  → Return to the previous level.

 For any other problem, please contact your installer

9 FAQ (Frequently Asked Questions)

9.1 Changing batteries

⇒ The battery level indicator shows  or my screen is off or the intensity of the backlighting is reduced.

→ Your battery level is very low. The batteries need to be replaced as soon as possible.

Note: your parameters and settings are stored on the unit's electronic board, so there is no risk of your information being lost when you change the batteries.

9.2 The temperature varies

⇒ When I pick up my terminal, the room temperature increases. Is this normal?

→ Yes, because the room temperature sensor is located on the bottom of the terminal. The temperature measured is therefore influenced by your hand. It will restabilise once you put the terminal back down.

9.3 The operating setpoints for the heat pump

⇒ I cannot find any examples for setting the heat pump in economy mode.

→ The setting of setpoints in comfort mode or in economy mode is based on the same principle. Simply select "economy" operation on your terminal instead of "comfort" operation and follow the rest of the instructions that are given in the example.

9.4 The radio signal

⇒ The radio signal indicator shows: 

→ Your control terminal is located too far from the heat pump. The data sent to the heat pump may not be taken into account. To resolve this issue, move the terminal closer to the heat pump to obtain the best possible signal.

⇒ The radio signal indicator shows: 

→ Your terminal has stopped communicating with the heat pump. There is no longer a radio signal between the two pieces of equipment. Move the terminal closer to the heat pump to obtain the best possible signal.

Please note:

If radio communication with the heat pump is lost, the following information is not displayed on the control terminal home screen:

- The electricity consumption trend
- The outdoor temperature value (replaced with 3 dashes)
- The operation type for zones 1 and 2 (ECO, COMFORT or PROG)
- The temperature in zone 2 (replaced with 3 dashes) if dual-zone control is active (option activated)
- The machine statuses (heating elements, boiler, compressor on, etc.)
- The operating mode configured by the user

→ The following information is displayed in the text area:

MACHINE COMMUNICATION LOST	
GND FLOOR	23.8°C
BEDROOM	----°C

10 Applicable standards and cleaning the product

10.1 Standards and directives

The product meets Low Voltage Directive 2006/95/CE and the standard NF C15-100.

It complies with:

- standard NF EN 60335-2-40, 60335-1.
- EMC standards EN 61000 6-2, 61000 6-3, 61000 3-3, 61000 4-4, 61000 4-6, EN 55014-1.
- radio standard EN 300-220.

10.2 Temperature, humidity

Operating limits:

- Temperature : 0 / +45°C
- Humidity : 10 / 90% without condensation

Storage and temperature limits:

- Temperature : -40 / +80°C
- Humidity : 5 / 90% without condensation

10.3 Cleaning the product

We recommend using a soft, dry cloth to keep this control terminal clean and to ensure the plastic components of your device are not scratched. It is prohibited to use water or any household cleaning products.

11 WEEE SYMBOL (Waste Electronic and Electrical Equipment)

Waste disposal by users in private waste facilities within the European Union

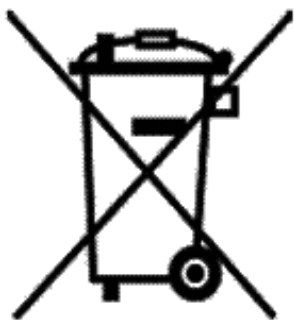

This symbol, either on the product or its packaging, indicates that the product must not be disposed of in ordinary household waste. Instead, it is your responsibility to ensure that you dispose of your waste by taking it to a designated recycling point for electrical and electronic devices. Separating your waste for recycling during disposal helps protect the environment and safeguard health. To find your nearest recycling centre, contact your local council or waste disposal service.





Registered address

Avenue Jean Falconnier B.P. 14
01350 Culoz - France
info@ciat.fr - www.ciat.com

Compagnie Industrielle
d'Applications Thermiques
Corporation with a capital of €26,728,480
R.C.S. Bourg-en-Bresse B 545.620.114



ISO9001 • ISO14001
OHSAS 18001

Residential Help Line
0 810 810 142

This document is not legally binding.
As part of our continuous drive to improve our products, CIAT reserves the
right to make any technical modifications without prior notice.