



EREBA He

Reversible air-to-water heat pump



*Simple, reliable,
high efficiency heat pump
Built-in hydraulic module
Equipped with **NHC control***

Nominal heating capacity: 4 to 15 kW
Nominal cooling capacity: 4 to 17 kW



Cooling and heating



Energy Soft



USE

The EREBA He air-to-water heat pump is designed for heating and cooling applications in new and existing individual homes and small businesses.

When installed alone, the EREBA He is compatible with low to medium temperature emitters (underfloor heating, fan coil units, water cassettes, radiators, mixed installations, etc.).

The EREBA He is also compatible with medium to high temperature emitters for boiler back up operation.

The EREBA He heat pump is installed outdoors in an open area, ideally as close as possible to the boiler room.

Each device is tested in the factory and delivered ready for operation.

RANGES

The EREBA He range of reversible heat pumps comprises 4 single-phase models and 2 three-phase models.

Operation in cooling mode with an outdoor temperature of 0 °C to 46 °C.

Operation in heating mode with an outdoor temperature of -20 °C to 35 °C.

If the heat pump is the only source of heat:

Below the equilibrium temperature, heating must be provided by another heating source or using an additional electrical supply actuated by the EREBA He.

If the heat pump is used for back up operation:

it operates down to the equilibrium point (temperature below which the heat pump can no longer keep up with heating requirements); below this point, the heat pump and boiler run alternately (heat pump or boiler).

COMPLIANCE

EMC: Electromagnetic Compatibility directive 2014/30/EU

RoHS: Restriction of Hazardous Substances directive 2011/65/EU

Ecodesign 2009/125/EC

Machinery 2006/42/EC

The new EREBA He air-to-water reversible heat pumps, with Inverter technology, have been designed for residential applications and for small commercial installations. They offer excellent energy efficiency and exceptionally quiet operation.



Ecodesign is the European environmental design directive, aimed at improving the energy efficiency of energy-related products (ErP) through regulation. Ciat supports initiatives to reduce the environmental impact of its products.

Specifications

- A vast operating range, both in cooling and heating mode, offering great performance across a broad range of temperatures.
- Twin Rotary DC Inverter compressors with pulse amplitude modulation (PAM) and pulse wave modulation (PWM) for increased reliability, reduced energy consumption and operation without vibrations, whatever the operating conditions.
- Variable speed fans with a patented innovative blade shape, ensuring better distribution of air at exceptionally low sound levels.
- Pre-configured or customisable water laws, for stable power levels which correspond to the losses.
- The option to connect and integrate the unit into existing heat sources or into an auxiliary heating source (approach with a single or dual energy source), which allows for increased savings and optimal comfort, no matter the weather conditions.
- Inlet and outlet connections to the three-way valve, to enable connection to a domestic hot water buffer tank, increase the flexibility of use, regardless of the application.
- A water outlet temperature of up to 60 °C for heating and domestic hot water in residential applications.
- Plug and play control for intrinsic maintenance and servicing safety.
- For enhanced safety, an incoming alarm signal can force the unit to shut down, and is compatible with external safety devices or control systems.
- Outgoing signal making it possible to control the operation of a customer's accelerator pump or additional pump to increase the versatility of the installation.

Advanced technology

- Electronic system management: several sensors placed in key positions within the refrigerant circuit detect the operating status of the system. Two micro-controls receive signals sent by the sensors; these are managed using advanced control algorithms and optimise the refrigerant flow rate and the operation of all the main components – the compressor, the fan motors, and the electronic expansion valve.
- The electronic expansion valve is an electronic dual-flow expansion device, which optimises the volume of refrigerant fluid present in the circuit and overheating, preventing the fluid from returning to the compressor. This device further improves system performance and reliability.
- The air management system, which comprises the axial flow fan, the orifice and the air discharge grille, guarantees minimised sound levels.

These units integrate the very latest technological innovations: R410A refrigerant fluid which does not contribute to ozone depletion, Twin Rotary DC Inverter compressors, a low-noise fan with an electronic control.

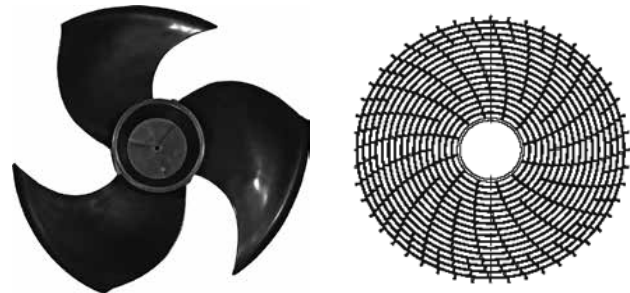

New patented fan blade shape and low pressure drop grille

- The new coil has a blue hydrophilic coating which allows water to migrate more easily to the exchanger using gravity. In particular, this innovation enables:
 - the frosting time to be increased by reducing the accumulation of frost on the coil
 - better defrosting by improving the flow of water over the fins
 Operation in heating mode is thereby improved.

Advanced performances

- The EREBA He offers extremely high energy efficiency, both in heating mode and in cooling mode, thereby guaranteeing significant energy savings. Large coils with high efficiency and optimised circuits ensure that all the combinations meet the European objectives concerning tax deductions relating to energy savings. The part load efficiency (seasonal energy efficiency) reaches the highest level in this industrial sector.
- Year-round comfort – the advanced technology used in the EREBA He provides users with optimised levels of comfort, in terms of water temperature regulation and the low sound level. The required temperature is obtained rapidly, and kept constant, without any fluctuations. The EREBA He offers optimised levels of comfort in both winter and summer.
- The EREBA He can operate at low ambient temperatures in cooling mode (from outdoor temperatures of 0 °C to 46 °C). To ensure the comfort of users, the units operate down to an outdoor temperature of -20 °C in heating mode, while in summer, they can produce hot water up to 60 °C, at an outdoor temperature of up to 35 °C for domestic hot water applications.
- The EREBA He also features the new Energy soft technology. This advanced control logic allows outdoor air to be extracted in order to guarantee energy-efficient defrosting without the use of the compressor. Unlike traditional defrosting technology, Energy soft has virtually no thermal impact on the water loop.

Environmental care

- Ozone-friendly R410A refrigerant.
- Fluid from the HFC family, a chlorine-free product which does not deplete the ozone layer.
- Very dense, so a smaller amount is required than other fluids.
- Highly efficient, it enables a high energy efficiency ratio (EER) to be obtained.
- The components of the EREBA He are free from hazardous substances.
- The packaging offers increased protection during transport and handling, and is 100 % recyclable.

Quick and simple to install and maintain

- Easy access to all internal components: simply undo three screws to remove the entire front panel, in order to access all of the components.
- The advanced circuit design and choice of components has enabled a compact unit to be created, with an exceptionally small footprint that is easy to transport even through narrow doors.
- The reduced weight of the unit, and the presence of a handle on the panels, ensure it is easy to transport.
- 3 bar safety valve fitted as standard.
- Internal two- or three-litre expansion vessel.
- Protection against high refrigerant temperatures.
- Water flow controller to ensure that the circuits contain enough water to operate correctly.
- Several options for the electrical cable outlets: prepunched holes in the casing panels enable the cable to be fed via the side, front, or rear.
- The EREBA He has gas type male couplings.
- The built-in hydraulic module reduces the space required and simplifies installation. Simply connect up all the connections: electrical, water supply, and return pipes.
- The coupling between the condensate draining pipe and the unit has an airtight rubber gasket.
- The mounting brackets have a specially designed shape to ensure that the unit is safely and securely attached to its base.

Twin Rotary DC Inverter compressors

- Advanced technology, which offers maximum energy efficiency, with high capacity available under peak conditions, and optimised efficiency at low and moderate compressor speeds. The EREBA He heat pump uses IPDU (intelligent power drive unit) hybrid inverter technology, which combines two electronic control logics: pulse amplitude modulation (PAM) and pulse width modulation (PWM) to ensure the compressor provides optimised operation under all conditions, to minimise temperature fluctuations, and ensure perfect control of individual comfort, whilst significantly reducing energy consumption.
 - PAM: the pulse amplitude modulation of the direct current controls the compressor under maximum load conditions (start-up and peak load), which increases the voltage at a fixed frequency. The compressor runs at a high speed to quickly reach the desired temperature.
 - PWM: the pulse width modulation of the direct current controls the compressor at partial load conditions, adjusting the frequency at fixed voltage. The compressor speed is adjusted with precision, and the system offers an enhanced level of comfort (no fluctuations in temperature) in operating conditions with exceptional efficiency.
- The compressor frequency is increased continuously up to the maximum level. This ensures there are no current peaks during the start-up phase, and provides a secure connection to a single-phase current supply, even for large capacity systems. The maximum operating current of the EREBA He is less than 8.9 A (for systems up to 5 kW) and less than 25.6 A for larger systems (15 kW). The inverter warm-up speed makes soft starts unnecessary by ensuring maximum capacity immediately.
- The two rotating compression cylinders, offset from one another by 180°, and the brushless DC motor with a perfectly balanced shaft, ensure that vibrations and noise are reduced to a minimum, even at very low operating speeds. This gives a very wide operating range between the minimum capacity and the maximum capacity in continuous operation, which guarantees that the system is always optimised and provides maximum comfort at exceptionally high levels of energy efficiency.
- The two rotating compression cylinders, the low vibrations and the low load imposed on the shaft ensure the compressor offers the best possible reliability and a long and trouble-free service life.
- All two-cylinder rotary compressors with a brushless DC inverter motor are equipped with crankcase heaters as standard.
- A double protective screen soundproofs the compressor, further reducing the sound levels.

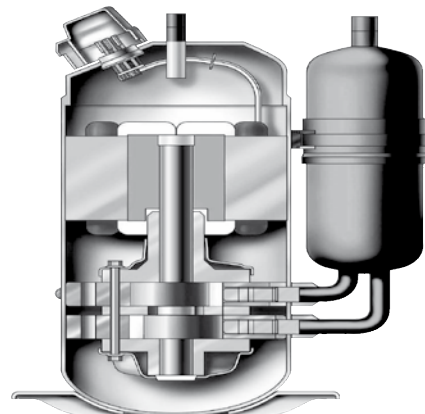

Absolute reliability

- Exceptional endurance tests:
 - All the units undergo tests at various stages of their manufacture to ensure tightness of the circuits, electrical conformity, and to check the water and refrigerant pressure.
 - At the end of production, all the unit's operating parameters are thoroughly tested.
 - Corrosion resistance test.
 - Accelerated ageing test on the critical components and on the fully-assembled units, simulating thousands of hours of continuous operation.
 - Impact testing on the packaging, to ensure that the units are suitably protected against accidental impacts.
 - Numerous, comprehensive test on-site.

Economical operation

- High energy efficiency:
 - The exceptionally high energy efficiency of EREBA He heat pumps is the result of a long selection and optimisation process.
 - The use of ambient air as the main energy source in residential heating applications considerably reduces energy consumption and CO₂ emissions.
 - Sleep mode, with reduced compressor speed at night, provides a low operating sound level, and significant reductions in energy consumption.
 - An easily adjustable and economic silent mode reduces the compressor speed.
 - The R-410A refrigerant is easier to use than other fluids.

NHC Control

NHC control associate with compressor and fan variable frequency driver combines intelligence with operating simplicity. The control constantly monitors all machine parameters and precisely manages the operation of compressor, expansion devices, fans and of the water heat exchanger water pump for optimum energy efficiency.

■ Ease-of-use

- NHC control can be associated with a new User interface (WUI) which allow an easy access to the configuration parameters (frequency compressor, refrigerant circuit temperature, sets points, air temp, entering water temp, alarm report...).
- This user interface is also very intuitive in its use. It allows reading and easy selection of the operating mode. The functions are represented by icons on the LCD backlit screen.

To facilitate the use of this interface, 3 levels of access are available: end user, installer and factory.

■ Key features

- Heating and cooling mode
- Predefined climatic curves (12) or customized climatic curve (Water temperature setpoint control)
- Air temperature set point control
- Scheduling mode
- Low noise level or night mode
- Antifreeze protection by triggering the internal accelerator pump
- Slab curing mode
- Backup electric heater controlled in 1 /2 /3 heat stage(s)
- Backup by oil or gas boiler
- Hydraulic module with control of the flow rate
- Managed an additional pump
- Swimming pool heating management between seasons
- Manage domestic hot water with or without
 - Anti-legionella mode
 - Auxiliary heater in the DHW tank
- Master-slave control of 4 units operating in parallel with operation time balancing and automatic changeover in case of a unit fault (sensor available as accessory).
- ModBUS Protocol

■ Choice of control product

Two options are available to actuate the EREBA heat pump:

- User interface WUI
- ModBus protocol

User Interface WUI



This interface can be installed up to 50 m away. It is connected to the NHC control using 4 H07RN-F 0.75 mm² cables.

The WUI has an internal sensor to measure the room temperature.

Regulation can be based on the room air temperature.

■ Modbus

Direct access with Modbus connection to set, configure and monitor the EREBA HE unit.

■ Large choice of input contacts:

- Remote On/Off contact.
- Remote Heat/Cool Contact: This switch is used to select the Cooling Mode (contact opened) or the Heating Mode (contact closed).
- Remote Economic Contact: This switch is used to select the regular Home Mode when contact is opened or the Economic Away Mode when contact is closed.
- Safety Input Contact: This switch is normally closed type, according to configuration it is used either to stop the unit, to ban the Heating Mode or to ban the Cooling Mode when contact is opened.

Several functions can be configured by the installer. They allow to adapt to the environment of the machine:

- Power Limitation / Night Mode: This switch is used to reduce the compressor maximum frequency to avoid noise.
- Off Peak: If the General Purpose Contact, configured to "Off Peak", is closed then the Electric Heat Stages are not allowed.
- Loadshed Request: If the General Purpose Contact, configured to "Loadshed Request", is closed then unit shall be stopped as soon as possible.
- Solar Input: If the General Purpose Contact, configured to "Solar Input", is closed then the unit is not allowed to run in Heating or DHW Mode because hot water is produced from a solar source.
- DHW Priority : When this input is closed, the unit is switching to Domestic Hot Water production regardless of the Space Heating demand and the current DHW schedule (need DHW sensor delivered in accessory).
- Anti-Legionella Cycle Request : When this input is closed, the Domestic Hot Water production is requested with the Anti-Legionella setpoint.
- Summer Switch : This switch is used to select the Winter (contact opened) or the Summer Mode (contact closed).
- Energy Meter Input : This input is used to count the number of pulses received from an external energy meter (not supplied)
- External Alarm Indication Input : When this input is opened, alarm is tripped. This alarm is for information only, it does not affect the unit operation.

■ Output remote contact available

Two output contacts can be chosen on the NHC board, based on the desired configuration:

Status: alert (Machine still running), Alarm, Standby, in Cooling or Heating or DHW or Defrost mode, Cooling Mode, Heating Mode, DHW Mode, defrost mode, indoor air temperature reached, electric stage 2 activated, electric stage 3 activated.

PHYSICAL DATA

EREBA He			5H	7H	11H	15H	11 HT	15 HT	
Heating									
Standard unit Full load performances*	HA1	Nominal capacity	kW	5,10	7,15	11,25	15,10	11,20	15,00
		COP	kW/kW	4,40	4,10	4,70	4,25	4,60	4,35
	HA2	Nominal capacity	kW	4,85	6,80	11,30	13,40	10,40	13,50
		COP	kW/kW	3,40	3,20	3,60	3,40	3,60	3,50
	HA3	Nominal capacity	kW	4,45	6,75	11,20	11,65	10,25	11,80
		COP	kW/kW	2,80	2,70	2,95	2,90	3,00	3,00
Standard unit Seasonal energy efficiency **	HA1	SCOP _{30/35 °C}	kWh/kWh	4,73	4,68	4,39	4,41	4,26	4,35
		η _{s heat 30/35 °C}	%	186	184	173	173	167	171
	HA3	SCOP_{47/55 °C}	kWh/kWh	3,32	3,36	3,35	3,45	3,34	3,40
		η_{s heat 47/55 °C}	%	130	131	131	135	131	133
		P _{rated}	kW	3,49	4,32	8,69	10,30	8,69	11,09
		Energy labelling		A++	A++	A++	A++	A++	A++
Cooling									
Standard unit Full load performances (*)	CA1	Nominal capacity	kW	4,00	5,55	11,20	12,80	10,65	13,00
		EER	kW/kW	3,10	3,10	3,40	3,10	3,40	3,20
		Eurovent class		A	A	A	A	A	A
	CA2	Nominal capacity	kW	4,85	8,00	13,70	16,00	13,75	17,00
		EER	kW/kW	4,35	4,00	4,60	4,10	4,65	4,15
		Eurovent class		A	A	A	A	A	A
Standard unit Seasonal energy efficiency **		SEER _{12/7 °C Comfort low temp.}	kWh/kWh	4,85	5,75	5,15	5,00	5,40	5,25
		η _{s cool 12/7 °C}	%	191	227	203	197	212	208
Sound levels									
Standard unit									
		Sound power level (2)	dB(A)	64	65	68	69	69	69
		Sound pressure level at 10 m(3)	dB(A)	33	34	37	38	38	38
Dimensions									
		Length	mm	908	908	908	908	908	908
		Width	mm	350	350	350	350	350	350
		Height	mm	821	821	1363	1363	1363	1363
Operating weight(1)									
		Standard unit	kg	57	69	115	115	121	121
Compressors Rotary compressor									
				1	1	1	1	1	1
Refrigerant R410A									
		Charge(1)	kg	1,10	1,60	2,80	2,80	3	3
Capacity control									
		Minimum capacity (4)	%	23 %	20 %	20 %	17 %	20 %	17 %
Condenser Grooved copper tubes, aluminium fins									
Fans Axial type									

- * In accordance with standard EN14511-3:2013.
- ** In accordance with standard EN14825:2016, average climate
- HA1 Heating mode conditions: Water heat exchanger water entering/leaving temperature 30°C/35°C, outside air temperature tdb/twb = 7°C db/6°C wb, evaporator fouling factor 0 m². kW
- HA2 Heating mode conditions: Water heat exchanger water entering/leaving temperature 40°C/45°C, outside air temperature tdb/twb = 7°C db/6°C wb, evaporator fouling factor 0 m². kW
- HA3 Heating mode conditions: Water heat exchanger water entering/leaving temperature 47°C/55°C, outside air temperature tdb/twb = 7°C db/6°C wb, evaporator fouling factor 0 m². kW
- CA1 Cooling mode conditions: evaporator water inlet/outlet temperature 12 °C/7 °C, outdoor air temperature 35 °C, evaporator fouling factor 0 m². kW
- CA2 Cooling mode conditions: evaporator water inlet/outlet temperature 23 °C/18 °C, outdoor air temperature 35 °C, evaporator fouling factor 0 m². kW
- η_{s heat 30/35 °C} & SCOP_{30/35 °C} Values calculated in accordance with standard EN14825:2016
- η_{s heat 47/55 °C} & SCOP_{47/55 °C} **Values in bold comply with Ecodesign Regulation (EU) No. 813/2013 for heating application**
- η_{s cool 12/7 °C} & SEER_{12/7 °C} Values calculated in accordance with standard EN14825:2016
- (1) Values are guidelines only. Refer to the unit nameplate
- (2) In dB re f=10-12 W, (A) weighting. Declared dual number noise emission value in accordance with ISO 4871 (with an associated uncertainty of +/-2dB(A)). Measured in accordance with ISO 9614-1 and certified by EUROVENT
- (3) In dB ref 20 μPa, (A) weighting. Declared dual number noise emission value in accordance with ISO 4871 (with an associated uncertainty of +/-2dB(A)). For information, calculated from the sound power level Lw(A)
- (4) Cooling Eurovent condition



Eurovent certified values

PHYSICAL DATA

EREBA He		5H	7H	11H	15H	11 HT	15 HT
Quantity		1	1	2	2	2	2
Maximum total air flow	l/s	800	800	1800	1800	1800	1800
Maximum rotational speed	rpm	560	660	820	820	820	820
Evaporator		Brazen plate heat exchanger					
Water volume	l	1,7	2,3	4,4	4,4	4,4	4,4
Hydraulic module		Circulator, relief valve, paddle flow switch, expansion tank					
Circulator		Centrifugal pump (variable speed)					
Expansion tank volume	l	2	2	3	3	3	3
Max. water-side operating pressure with hydraulic module ⁽⁵⁾	kPa	300	300	300	300	300	300
Water connections							
Inlet diameter (BSP GAS)	inch	1	1	1	1	1	1
Outlet diameter (BSP GAS)	inch	1	1	1	1	1	1
Chassis paint colour	Colour code:	RAL 7035	RAL 7035	RAL 7035	RAL 7035	RAL 7035	RAL 7035

(5) The min. water-side operating pressure with variable speed hydraulic module is 40 kPa.

ELECTRICAL DATA

EREBA He		5H	7H	11H	15H	11 HT	15 HT
Nominal power supply	V-ph-Hz	230-1-50	230-1-50	230-1-50	230-1-50	400-3N-50	400-3N-50
Voltage range	V	220-240	220-240	220-240	220-240	380-415	380-415
Current at full load	A	8,9	16,7	23,3	25,6	16,8	16,8
Fuse capacity	A	16	20	32	32	20	20
Electrical power cable section (H07 RN-F)	mm ²	2,5	2,5	4	4	2,5	2,5
WUI (user interface) cable section	mm ²	H07RN-F 4 x 0.75					
Circuit breaker	Am	10	16	25	25	16	16

OPERATING LIMITS

Cooling Cycle			
Evaporator Water Temperature	°C	Minimum	Maximum
Entering water temperature at start-up		6	30
Leaving water temperature during operation		4	18
Condenser Air Temperature			
Standard unit	°C	Minimum	Maximum
		0 / 10 (1)	46
Heating Cycle			
Condenser Water Temperature	°C	Minimum	Maximum
Entering water temperature at start-up		15	52 / 59 (2)
Leaving water temperature during operation		20	60
Evaporator Air Temperature			
Standard unit	°C	Minimum	Maximum
		-20 (3)	35

- (1) 0 °C for EREBA He 7-15 and 10 °C for EREBA He 5
- (2) 52 °C with unit stopped at EWT threshold and 59 °C with unit running at EWT threshold
- (3) For operation at outdoor ambient temperature below 0 °C (heating mode), the antifreeze protection should be applied by the installer, either using an antifreeze solution or a trace heater.

Operating range, cooling mode

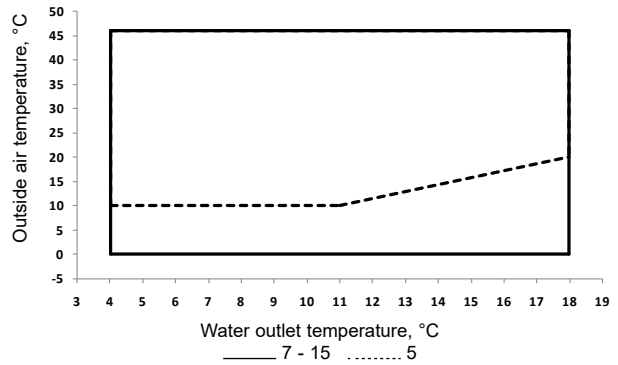

Operating range, heating mode

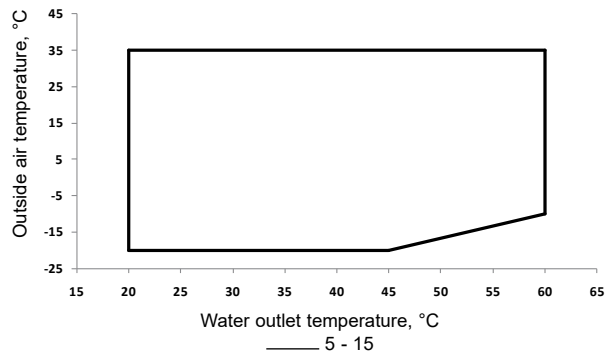

AVAILABLE STATIC PRESSURE

EREBA He 5 H

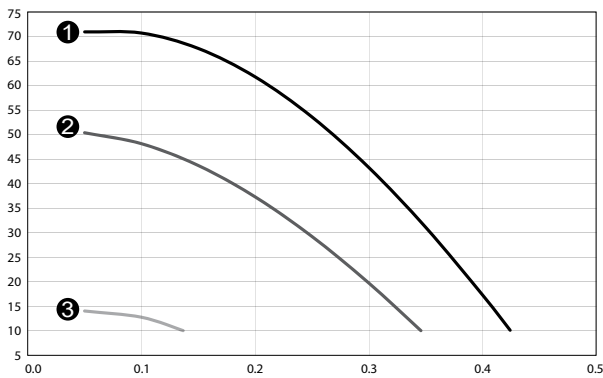

EREBA He 7 H

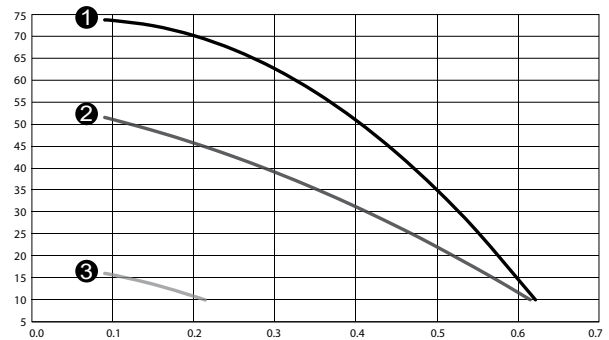

EREBA He 11 and 15 H and HT

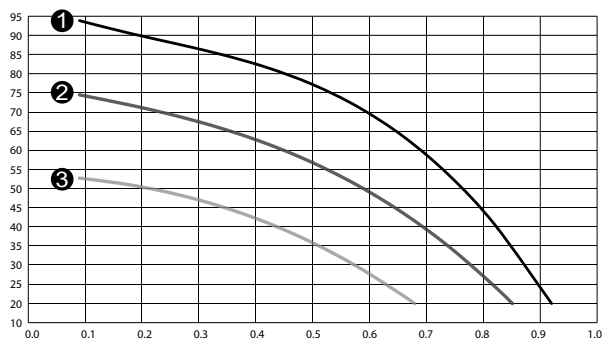

- ① High speed
- ② Medium speed
- ③ Low speed

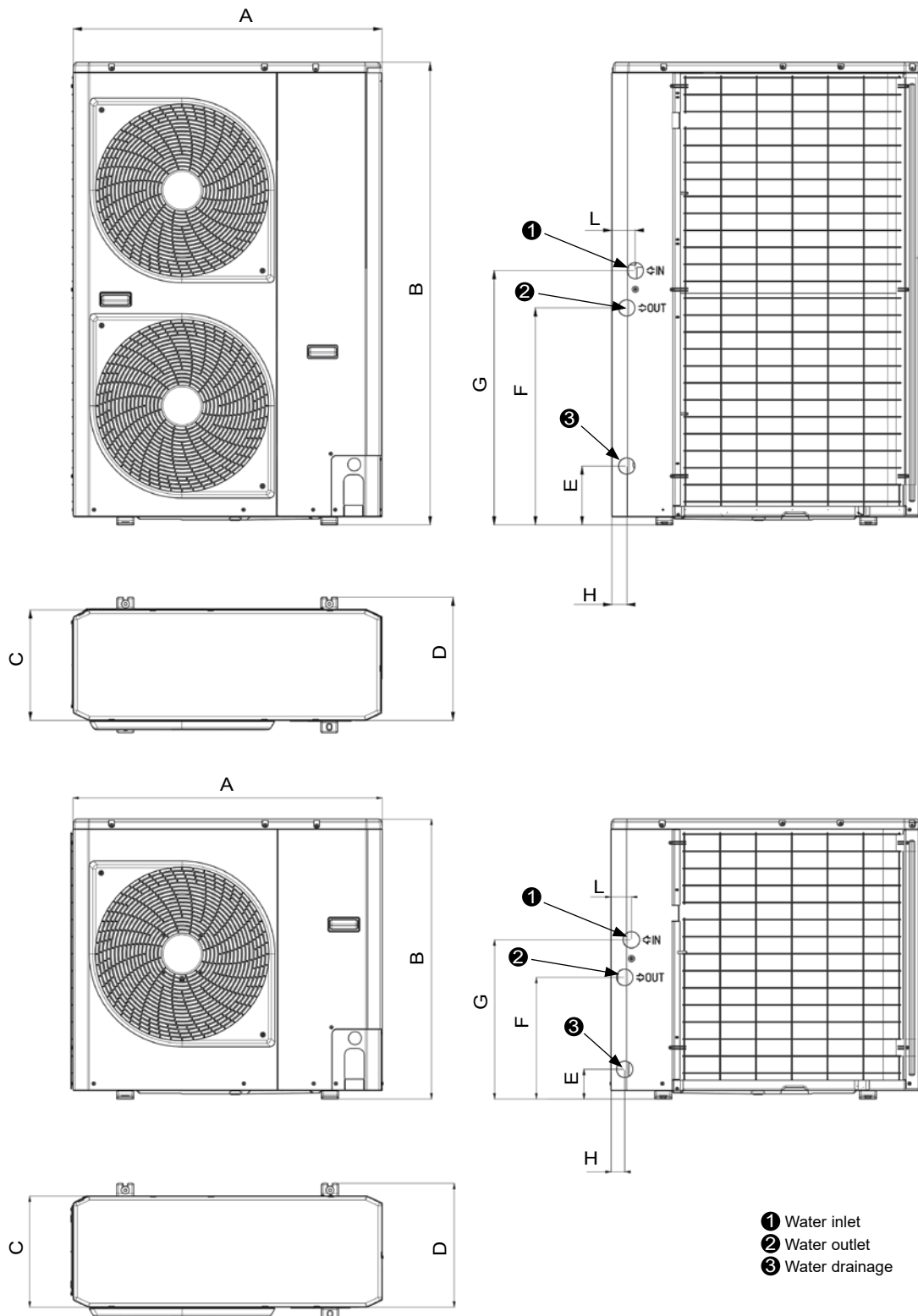
DIMENSIONS (MM)

EREBA He	A	B	C	D	E	F	G	H	L	mass (kg)
5H	908	821	326	350	87	356	466	40	60	57
7H	908	821	326	350	87	356	466	40	60	69
11H	908	1363	326	350	169	645	744	43	73	115
15H	908	1363	326	350	169	645	744	43	73	115
11HT	908	1363	326	350	169	645	744	43	73	121
15HT	908	1363	326	350	169	645	744	43	73	121

CONDENSATE DRAINING PIPE AND PREPUNCHED HOLES IN THE BASE

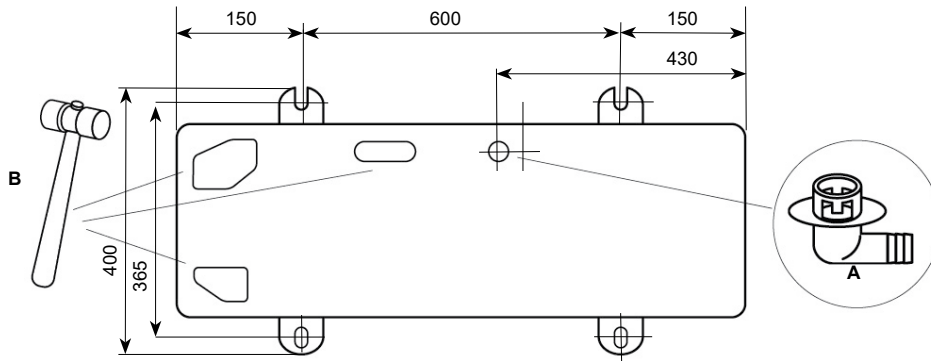

If drainage is provided by the draining pipe, connect the nipple (A) and use the draining pipe (internal diameter: 16 mm) available commercially. If the installation is to be located in a very cold area or area with high snowfall levels, where the condensate draining pipe could freeze, the drainage capacity of the pipe must be checked, or a electric heat trace cable must be added.

The drainage capacity increases if the prepunched holes in the condensate pan are open (open the prepunched holes outwards using a hammer (B), etc.).

FREE SPACE (MM)

Installation of a single unit

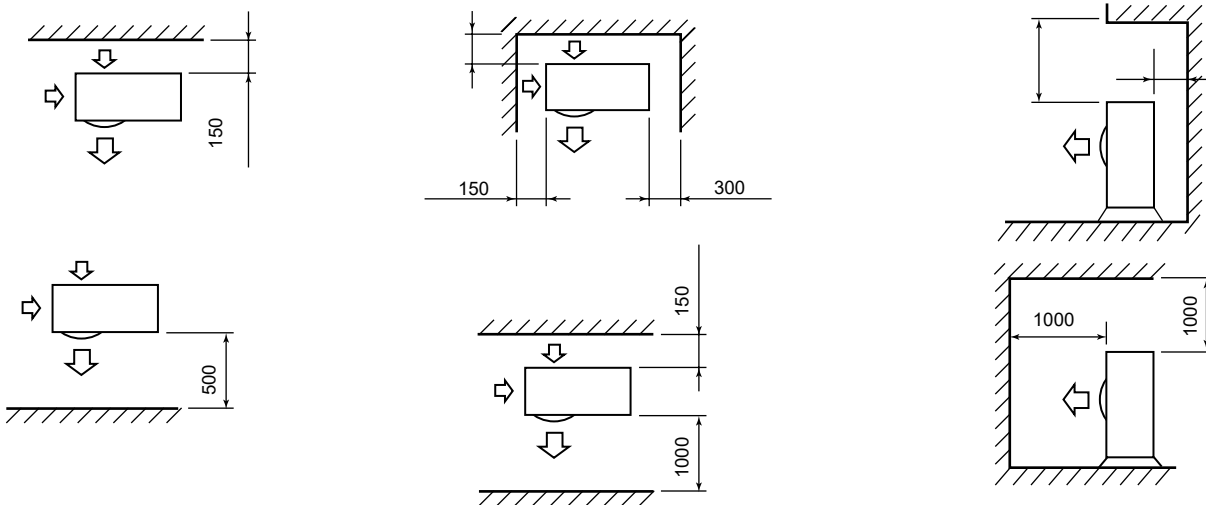

Installation of multiple units

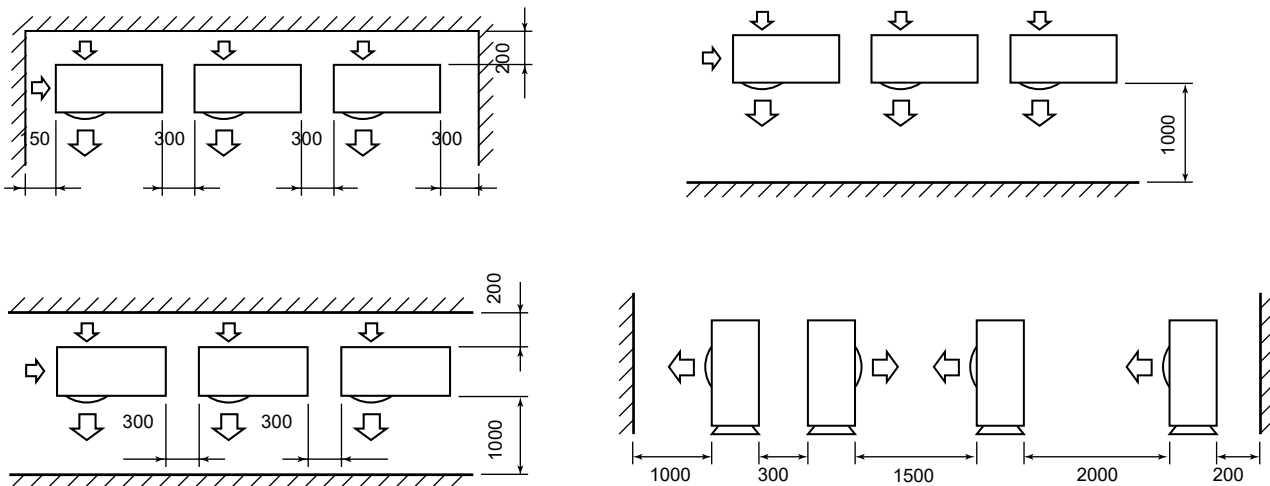

Note: The height of obstacles at the front and rear should be less than the height of the outdoor unit

HEATING MODE SELECTION TABLE

EREBA He

EREBA He	LWT °C	Outdoor air dry temperature (wet temperature), °C																				
		-20 (-21)						-15 (-16)						-10 (-11)								
		Hc			COP			q	Hc			COP			q	Hc			COP			q
		kW			kW/kW			l/s	kW			kW/kW			l/s	kW			kW/kW			l/s
	Nom	Min	Max	Nom	Min	Max	Nom	Nom	Min	Max	Nom	Min	Max	Nom	Nom	Min	Max	Nom	Min	Max	Nom	
5H	35	1,00	0,42	1,00	1,86	1,91	1,86	0,050	2,26	0,49	2,34	2,14	2,23	2,11	0,108	2,58	0,56	2,80	2,41	2,61	2,39	0,124
7H		1,81	0,68	1,81	2,00	1,87	2,00	0,117	3,89	0,76	3,89	2,29	2,52	2,29	0,187	3,90	0,84	4,66	2,81	2,89	2,34	0,187
11H		2,60	1,74	2,60	1,52	1,54	1,52	0,167	2,88	1,92	2,88	1,82	1,91	1,82	0,167	6,16	2,13	7,65	2,40	2,89	2,24	0,347
11 HT		2,65	1,86	2,65	1,55	1,60	1,55	0,167	2,91	1,96	2,91	1,87	1,95	1,87	0,167	6,32	2,24	7,95	2,50	2,95	2,18	0,303
15		2,60	1,74	2,60	1,52	1,54	1,52	0,127	2,88	1,92	2,88	1,82	1,91	1,82	0,164	7,59	2,13	8,18	2,35	2,89	2,22	0,419
15 HT		2,65	1,86	2,65	1,55	1,61	1,55	0,167	2,91	1,96	2,91	1,87	1,95	1,87	0,167	7,78	2,24	8,51	2,44	2,95	2,15	0,419
5H	45	0,78	0,39	0,78	1,71	1,87	1,71	0,050	2,05	0,45	2,10	2,09	2,14	1,94	0,098	2,47	0,52	2,67	2,21	2,39	2,20	0,118
7H		1,69	0,66	1,69	1,66	2,12	1,66	0,117	3,84	0,73	3,84	1,90	2,19	1,90	0,184	3,68	0,81	3,84	2,21	2,26	1,94	0,177
11H		2,34	1,60	2,34	1,28	1,29	1,28	0,167	2,73	1,79	2,73	1,52	1,57	1,52	0,167	3,44	1,92	3,44	1,89	1,93	1,89	0,194
11 HT		2,39	1,71	2,39	1,30	1,35	1,30	0,167	2,76	1,83	2,76	1,56	1,60	1,56	0,167	3,53	1,96	3,53	1,94	1,97	1,94	0,169
15		2,34	1,60	2,34	1,28	1,29	1,28	0,114	2,73	1,79	2,73	1,52	1,57	1,52	0,156	3,44	1,92	3,44	1,89	1,93	1,89	0,194
15 HT		2,39	1,71	2,39	1,30	1,35	1,30	0,167	2,76	1,83	2,76	1,56	1,60	1,56	0,167	3,53	1,96	3,53	1,94	1,97	1,94	0,194
5H	55															2,39	0,49	2,58	1,91	2,06	1,88	0,115
7H																3,05	0,74	3,35	1,80	2,07	1,75	0,146
11H																2,97	1,85	2,97	1,30	1,29	1,30	0,167
11 HT																3,03	1,89	3,03	1,32	1,34	1,32	0,167
15																2,97	1,85	2,97	1,30	1,29	1,30	0,158
15 HT																3,03	1,89	3,03	1,32	1,34	1,32	0,167
5H	60															2,33	0,46	2,50	1,86	2,01	1,83	0,112
7H																2,68	0,69	2,68	1,54	1,84	1,54	0,129
11H																2,44	1,69	2,44	1,10	1,11	1,10	0,167
11 HT																2,47	1,72	2,47	1,12	1,13	1,12	0,167
15																2,44	1,69	2,44	1,10	1,11	1,10	0,123
15 HT																2,48	1,72	2,48	1,12	1,13	1,12	0,167

EREBA He	LWT °C	Outdoor air dry temperature (wet temperature), °C																				
		-7 (-8)						2 (1)						7 (6)								
		Hc			COP			q	Hc			COP			q	Hc			COP			q
		kW			kW/kW			l/s	kW			kW/kW			l/s	kW			kW/kW			l/s
	Nom	Min	Max	Nom	Min	Max	Nom	Nom	Min	Max	Nom	Min	Max	Nom	Nom	Min	Max	Nom	Min	Max	Nom	
5H	35	3,35	0,64	3,55	3,01	3,19	3,00	0,160	3,61	1,30	3,83	3,79	3,90	3,66	0,750	5,10	0,82	5,27	4,40	4,58	4,34	0,248
7H		4,10	0,94	4,95	3,00	3,21	2,48	0,196	4,90	1,04	5,68	3,57	3,71	3,24	1,040	7,15	1,36	8,77	4,10	4,46	3,31	0,343
11H		6,81	2,52	8,50	2,93	2,99	2,80	0,379	8,35	5,22	9,65	3,68	3,92	3,58	1,790	11,25	3,73	13,67	4,70	4,90	4,21	0,544
11 HT		6,98	2,57	8,20	3,00	3,05	2,85	0,335	8,32	5,28	10,56	3,63	4,48	3,49	1,950	11,20	3,80	14,19	4,60	4,99	4,32	0,559
15		8,50	2,52	9,00	2,82	2,99	2,70	0,464	9,65	5,22	10,42	3,58	3,92	3,47	2,120	15,10	3,73	15,92	4,25	4,90	4,16	0,694
15 HT		8,72	2,57	9,15	2,90	3,05	2,75	0,464	9,65	5,28	10,40	3,56	4,48	3,37	2,250	15,00	3,80	16,52	4,35	4,99	4,27	0,694
5H	45	3,17	0,60	3,40	2,65	2,81	2,60	0,152	3,44	1,15	3,62	3,01	2,79	2,93	0,710	4,85	0,74	4,99	3,40	3,52	3,34	0,234
7H		3,83	0,90	4,58	2,33	2,51	2,06	0,184	4,31	1,00	5,53	2,81	2,71	2,56	0,990	6,80	1,31	7,96	3,20	3,42	2,83	0,328
11H		6,48	2,37	7,95	2,42	2,44	2,29	0,361	7,53	4,93	9,41	2,96	3,03	2,92	1,710	11,30	3,58	12,64	3,60	3,73	3,31	0,555
11 HT		6,63	2,42	8,13	2,47	2,49	2,34	0,318	8,18	5,32	9,37	3,12	3,17	2,88	1,690	10,40	3,65	13,12	3,60	3,80	3,35	0,565
15		7,88	2,37	8,40	2,29	2,44	2,20	0,430	9,41	4,93	9,24	2,92	2,97	2,84	2,020	13,40	3,58	15,31	3,40	3,73	3,28	0,647
15 HT		8,06	2,42	8,60	2,34	2,49	2,24	0,430	8,70	5,32	10,46	2,94	3,17	2,78	2,060	13,50	3,65	15,88	3,50	3,80	3,32	0,647
5H	55	2,90	0,56	2,96	1,99	2,10	1,95	0,139	3,30	1,09	3,30	2,42	2,63	2,42	0,670	4,41	0,68	4,41	2,79	2,95	2,79	0,211
7H		3,17	0,85	3,17	1,90	2,30	1,86	0,152	3,83	0,97	3,83	2,22	2,44	2,22	0,860	6,51	1,27	7,35	2,59	2,80	2,43	0,312
11H		5,70	2,29	7,06	1,82	1,88	1,76	0,317	7,59	5,23	7,47	2,40	2,48	2,21	1,540	9,46	3,22	11,08	2,69	2,73	2,46	0,453
11 HT		5,81	2,34	7,20	1,85	1,92	1,79	0,279	7,66	5,62	9,43	2,47	2,54	2,39	1,600	9,93	3,28	11,63	2,72	2,76	2,48	0,476
15		6,93	2,29	7,40	1,73	1,88	1,67	0,378	7,47	5,23	7,47	2,21	2,36	2,21	1,660	13,09	3,22	14,32	2,54	2,73	2,43	0,615
15 HT		7,07	2,34	7,55	1,76	1,92	1,70	0,378	8,70	5,62	10,24	2,42	2,54	2,32	1,960	13,61	3,28	14,90	2,56	2,76	2,45	0,615
5H	60	2,56	0,52	2,82	1,93	2,04	1,89	0,123	3,10	1,00	3,10	2,20	2,56	2,20	0,620	3,88	0,65	3,88	2,44	2,66	2,44	0,186
7H		2,79	0,81	2,79	1,62	2,05	1,62	0,134	3,56	0,96	3,56	2,07	2,13	2,07	0,730	5,16	1,25	5,16	2,15	2,32	2,15	0,247
11H		4,99	2,15	6,30	1,46	1,45	1,45	0,278	5,96	4,87	7,45	2,09	2,14	2,07	1,640	8,48	3,10	9,94	2,10	2,12	2,03	0,406
11 HT		5,06	2,20	6,39	1,46	1,47	1,45	0,243	7,02	5,38	9,09	2,20	2,31	2,15	1,500	8,90	3,16	10,44	2,21	2,23	2,13	0,427
15		6,27	2,15	6,72	1,44	1,45	1,40	0,342	7,45	4,87	7,45	2,07	2,04	2,07	1,860	12,40	3,10	13,62	2,06	2,12	2,01	0,582
15 HT		6,37	2,20	6,82	1,44	1,47	1,40	0,342	8,26	5,38	9,99	2,20	2,31	2,12	1,840	12,90	3,16	14,17	2,10	2,14	2,06	0,582

Key
 LWT Water outlet temperature, °C
 Hc Heating capacities, kW
 Nom Nominal
 Min Minimum
 Max Maximum
 COP Coefficient of performance, kW/kW
 q Water flow rate to the condenser, l/s

Application data
 Application data
 Standard units, refrigerant: R-410A
 Condenser water outlet or water inlet temperature difference: 5 K
 Condenser fluid: water
 Fouling coefficient: 0 m² kW
 Established performance as per EN 14511

HEATING MODE SELECTION TABLE

EREBA He

EREBA He	LWT °C	Outdoor air dry temperature (wet temperature), °C						
		10 (9)						
		Hc			COP			q
		kW			kW/kW			l/s
		Nom	Min	Max	Nom	Min	Max	Nom
5H	35	5,54	0,92	5,88	4,66	4,86	4,51	0,266
7H		7,38	1,44	8,65	4,35	4,69	3,94	0,354
11H		12,14	3,87	14,51	4,94	5,30	4,44	0,581
11 HT		12,44	4,03	15,24	5,04	5,41	4,57	0,596
15		15,86	4,15	17,23	4,40	5,88	4,25	0,736
15 HT		15,75	4,03	17,15	4,54	5,41	4,44	0,736
5H	45	5,05	0,83	5,36	3,69	3,85	3,60	0,242
7H		7,04	1,36	8,36	3,13	3,37	3,21	0,337
11H		11,37	3,84	13,37	3,85	4,27	3,45	0,544
11 HT		11,65	3,92	14,04	3,93	4,36	3,52	0,559
15		14,40	3,84	14,40	3,51	4,27	3,51	0,691
15 HT		15,20	3,92	16,58	3,76	4,36	3,48	0,710
5H	55	4,61	0,76	4,61	2,88	3,01	2,88	0,221
7H		6,53	1,30	7,58	2,73	3,01	2,68	0,313
11H		10,07	3,47	11,70	2,83	2,85	2,43	0,482
11 HT		10,36	3,61	12,29	2,88	2,91	2,55	0,497
15		11,81	3,47	11,81	2,93	3,14	2,93	0,556
15 HT		14,33	3,61	15,64	2,87	2,91	2,82	0,667
5H	60	4,14	0,73	4,14	2,58	2,74	2,58	0,199
7H		5,96	1,22	5,96	2,26	2,49	2,26	0,286
11H		8,20	2,89	8,20	2,31	2,33	2,31	0,392
11 HT		8,61	3,01	8,61	2,37	2,43	2,37	0,413
15		10,68	2,89	10,68	2,64	2,79	2,64	0,493
15 HT		8,61	3,01	8,61	2,37	2,43	2,37	0,392

Key	
LWT	Water outlet temperature, °C
Hc	Heating capacities, kW
Nom	Nominal
Min	Minimum
Max	Maximum
COP	Coefficient of performance, kW/kW
q	Water flow rate to the condenser, l/s

Application data
Application data
Standard units, refrigerant: R-410A
Condenser water outlet or water inlet temperature difference: 5 K
Condenser fluid: water
Fouling coefficient: 0 m ² kW
Established performance as per EN 14511

COOLING MODE SELECTION TABLE

EREBA He

EREBA He	LWT °C	Outside air dry temperature, °C																				
		5						15						25								
		Cc			EER			q	Cc			EER			q	Cc			EER			q
		kW			kW/kW			l/s	kW			kW/kW			l/s	kW			kW/kW			l/s
	Nom	Min	Max	Nom	Min	Max	Nom	Nom	Min	Max	Nom	Min	Max	Nom	Nom	Min	Max	Nom	Min	Max	Nom	
5H	5							1,07	1,07	1,07	6,72	6,72	6,72	0,051	2,14	0,91	2,14	4,01	6,07	4,01	0,103	
7H		5,44	0,76	5,44	7,59	10,74	7,59	0,262	5,37	0,76	5,37	5,57	7,57	5,57	0,252	5,60	0,59	6,45	3,85	4,25	3,76	0,263
11H		13,06	2,56	16,02	6,24	12,27	5,48	0,626	12,39	3,57	13,24	5,48	7,78	5,18	0,594	11,51	3,05	13,27	4,30	4,73	3,88	0,552
11 HT		13,19	2,59	16,18	6,30	12,39	5,54	0,633	12,52	3,61	13,37	5,54	7,86	5,23	0,600	11,62	3,09	13,40	4,35	4,78	3,91	0,557
15		15,00	2,56	16,02	5,95	12,27	5,48	0,704	13,24	3,57	13,24	5,18	7,78	5,18	0,621	13,27	3,05	13,27	3,88	4,73	3,88	0,623
15 HT		15,15	2,59	16,18	6,01	12,39	5,54	0,711	13,37	3,61	13,37	5,23	7,86	5,23	0,628	13,40	3,09	13,40	3,91	4,78	3,91	0,629
5H	7							1,34	1,34	1,34	7,50	7,50	7,50	0,064	2,42	1,01	2,42	4,59	6,49	4,59	0,116	
7H		6,03	0,93	6,03	7,98	13,34	7,98	0,283	5,59	0,95	5,59	6,15	9,55	6,15	0,275	6,14	0,77	6,78	4,31	5,62	4,16	0,288
11H		13,92	2,78	17,09	7,12	12,79	6,67	0,667	13,19	3,88	14,09	5,64	8,25	5,33	0,632	12,25	3,38	14,12	4,44	5,18	4,00	0,587
11 HT		14,05	2,80	17,26	7,19	12,92	6,74	0,674	13,32	3,92	14,23	5,70	8,33	5,39	0,639	12,37	3,41	14,26	4,48	5,23	4,04	0,593
15		16,00	2,78	17,09	6,75	12,79	6,67	0,751	14,09	3,88	14,09	5,33	8,25	5,33	0,661	14,12	3,38	14,12	4,00	5,18	4,00	0,663
15 HT		16,32	2,80	17,26	6,89	12,92	6,74	0,766	14,37	3,92	14,37	5,39	8,33	5,39	0,675	14,40	3,41	14,26	4,04	5,23	4,04	0,676
5H	10							1,49	1,49	1,49	8,47	8,47	8,47	0,071	2,71	1,17	2,71	5,21	7,31	5,21	0,130	
7H		6,54	1,01	6,54	8,64	17,08	8,64	0,307	6,04	1,06	6,04	6,43	12,38	6,43	0,301	6,79	0,87	6,84	4,71	7,54	4,54	0,319
11H		15,29	3,18	18,78	9,76	14,29	9,19	0,733	14,48	4,43	15,93	5,95	9,56	5,47	0,694	13,45	3,95	15,47	4,69	6,19	4,22	0,645
11 HT		15,44	3,22	18,97	9,85	14,43	9,28	0,740	14,62	4,47	16,09	6,01	9,66	5,53	0,701	13,59	3,99	15,63	4,74	6,26	4,26	0,651
15		17,58	3,18	18,78	9,55	14,29	9,19	0,825	15,93	4,43	15,93	5,47	9,56	5,47	0,748	15,47	3,95	15,47	4,22	6,19	4,22	0,726
15 HT		17,93	3,22	18,97	9,64	14,43	9,28	0,842	16,25	4,47	16,25	5,53	9,66	5,53	0,763	15,78	3,99	15,63	4,26	6,26	4,26	0,741
5H	15														3,48	1,41	3,48	6,54	8,46	6,54	0,167	
7H		7,39	1,16	7,39	9,69	18,62	9,69	0,347	6,93	1,25	6,93	7,16	14,51	7,16	0,345	7,87	1,05	8,69	5,34	10,71	5,12	0,370
11H		5,69	5,69	5,69	15,35	15,35	15,35	0,273	16,65	5,37	18,58	6,61	14,09	5,96	0,798	15,49	4,94	18,96	5,21	9,06	4,37	0,743
11 HT		5,75	5,75	5,75	15,50	15,50	15,50	0,276	16,82	5,42	18,76	6,68	14,23	6,02	0,806	15,64	4,99	19,15	5,26	9,15	4,41	0,750
15		5,69	5,69	5,69	15,35	15,35	15,35	0,267	18,58	5,37	18,58	5,96	14,09	5,96	0,872	17,77	4,94	18,96	4,65	9,06	4,37	0,834
15 HT		5,86	5,75	5,86	15,50	15,50	15,50	0,275	18,76	5,42	18,76	6,02	14,23	6,02	0,898	18,30	4,99	19,15	4,70	9,15	4,41	0,859
5H	18														5,30	1,56	5,30	6,73	9,63	6,73	0,254	
7H		8,20	2,85	8,20	10,54	19,58	10,54	0,385	7,74	1,67	7,74	7,80	16,07	7,80	0,386	9,05	1,46	9,71	5,73	12,82	5,48	0,425
11H		5,99	5,99	5,99	17,96	17,96	17,96	0,287	17,83	5,81	19,90	7,06	16,22	6,34	0,855	16,59	5,41	20,30	5,55	12,18	4,61	0,795
11 HT		6,05	6,05	6,05	18,14	18,14	18,14	0,290	18,01	5,87	20,10	7,13	16,38	6,40	0,863	16,75	5,46	20,50	5,60	12,31	4,66	0,803
15		5,99	5,99	5,99	17,96	17,96	17,96	0,287	19,90	5,81	19,90	6,34	18,25	6,34	0,934	19,02	5,41	20,30	4,91	12,18	4,61	0,893
15 HT		6,05	6,05	6,05	18,14	18,14	18,14	0,290	20,10	5,87	20,10	6,40	18,43	6,40	0,962	19,59	5,46	20,50	4,96	12,31	4,66	0,920

Key
LWT Water outlet temperature, °C
Cc Cooling capacity kW
Nom Nominal
Min Minimum
Max Maximum
EER Coefficient of performance, kW/kW
q Evaporator water flow rate, l/s

Application data
 Standard units, refrigerant: R-410A
 Condenser water outlet or water inlet temperature difference: 5 K
 Condenser fluid: water
 Fouling coefficient: 0 m² kW
 Established performance as per EN 14511

COOLING MODE SELECTION TABLE

EREBA He

EREBA He	LWT °C	Outside air dry temperature, °C													
		35							45						
		Cc			EER			q	Cc			EER			q
		kW			kW/kW			l/s	kW			kW/kW			l/s
	Nom	Min	Max	Nom	Min	Max	Nom	Nom	Min	Max	Nom	Min	Max	Nom	
5H	5	3,69	0,80	3,75	2,81	4,56	2,77	0,177	1,87	0,66	1,87	2,00	3,45	2,00	0,090
7H		4,86	0,42	5,39	2,93	3,41	2,77	0,228	1,96	0,36	1,96	2,00	2,44	2,00	0,092
11H		9,52	2,27	12,88	2,95	3,00	2,89	0,456	6,80	3,05	6,80	2,23	2,30	2,23	0,326
11 HT		9,61	2,29	13,01	2,98	3,03	2,92	0,461	6,87	3,08	6,87	2,26	2,32	2,26	0,329
15		12,02	2,27	12,88	2,91	3,00	2,89	0,564	6,80	3,05	6,80	2,23	2,30	2,23	0,319
15 HT		12,14	2,29	13,01	2,94	3,03	2,92	0,570	6,87	3,08	6,87	2,26	2,32	2,26	0,323
5H	7	4,00	0,89	4,09	3,10	4,92	2,95	0,193	2,13	0,75	2,13	2,14	3,70	2,38	0,102
7H		5,55	0,50	5,95	3,10	3,85	2,94	0,265	2,23	0,44	2,23	2,28	2,77	2,28	0,105
11H		11,20	2,61	13,70	3,40	3,45	2,98	0,538	7,93	3,53	7,93	2,50	2,64	2,50	0,380
11 HT		10,65	2,64	13,84	3,40	3,48	3,01	0,544	8,00	3,57	8,00	2,52	2,67	2,52	0,384
15		12,80	2,61	13,70	3,10	3,45	2,98	0,594	7,93	3,53	7,93	2,50	2,64	2,50	0,372
15 HT		13,00	2,64	13,84	3,20	3,48	3,01	0,614	8,00	3,57	8,00	2,52	2,67	2,52	0,380
5H	10	4,27	1,03	4,39	3,35	5,46	3,25	0,205	2,20	0,87	2,20	2,64	4,06	2,64	0,105
7H		5,98	0,63	6,70	3,35	4,50	3,18	0,281	2,46	0,55	2,46	2,53	3,28	2,53	0,116
11H		12,15	3,21	15,02	3,53	3,62	3,15	0,583	8,47	4,00	8,47	2,74	2,75	2,74	0,406
11 HT		12,28	3,25	15,17	3,57	3,66	3,18	0,589	8,55	4,04	8,55	2,77	2,77	2,77	0,410
15		14,04	3,21	15,02	3,31	3,62	3,15	0,659	8,47	4,00	8,47	2,74	2,75	2,74	0,397
15 HT		14,32	3,25	15,17	3,38	3,66	3,18	0,672	8,55	4,04	8,55	2,77	2,77	2,77	0,405
5H	15	4,48	1,26	5,31	3,89	6,36	3,73	0,215	2,59	1,08	2,59	3,12	4,67	3,12	0,124
7H		6,99	0,84	7,75	3,77	5,58	3,60	0,328	2,96	0,74	2,96	3,10	4,12	3,10	0,135
11H		14,05	4,25	17,24	3,94	5,42	3,46	0,674	9,75	4,82	9,75	3,19	3,15	3,19	0,467
11 HT		14,19	4,29	17,42	3,98	5,47	3,50	0,680	9,85	4,87	9,85	3,22	3,18	3,22	0,472
15		16,15	4,25	17,24	3,65	5,42	3,46	0,758	9,75	4,82	9,75	3,19	3,15	3,19	0,458
15 HT		16,63	4,29	17,42	3,76	5,47	3,50	0,781	9,85	4,87	9,85	3,22	3,18	3,22	0,471
5H	18	4,85	1,40	5,50	4,35	6,89	4,01	0,232	2,85	1,20	2,85	3,33	5,04	3,33	0,137
7H		8,00	0,97	8,72	4,00	6,24	3,84	0,381	2,31	2,31	2,31	3,53	3,53	3,53	0,102
11H		13,70	4,74	18,46	4,60	7,02	3,65	0,658	10,58	5,42	10,58	3,45	3,75	3,45	0,507
11 HT		13,75	4,79	18,64	4,65	7,09	3,68	0,665	10,68	5,47	10,68	3,48	3,79	3,48	0,512
15		16,00	4,74	18,46	4,10	7,02	3,65	0,756	10,58	5,42	10,58	3,45	3,75	3,45	0,497
15 HT		17,00	4,79	18,64	4,15	7,09	3,68	0,786	10,68	5,47	10,68	3,48	3,79	3,48	0,511

Key

LWT	Water outlet temperature, °C
Cc	Cooling capacity, kW
Nom	Nominal
Min	Minimum
Max	Maximum
EER	Coefficient of performance, kW/kW
q	Evaporator water flow rate, l/s

Application data

Standard units, refrigerant: R-410A
Condenser water outlet or water inlet temperature difference: 5 K
Condenser fluid: water
Fouling coefficient: 0 m ² kW
Established performance as per EN 14511

HYDRAULIC MODULE

The hydraulic module enables the installation time to be reduced. The unit is factory-equipped with the main hydraulic components needed for installation: variable speed accelerator pump, expansion vessel and safety valve.

The heat exchanger and the hydraulic module are protected from frost down to -10 °C by the operation of the pump.

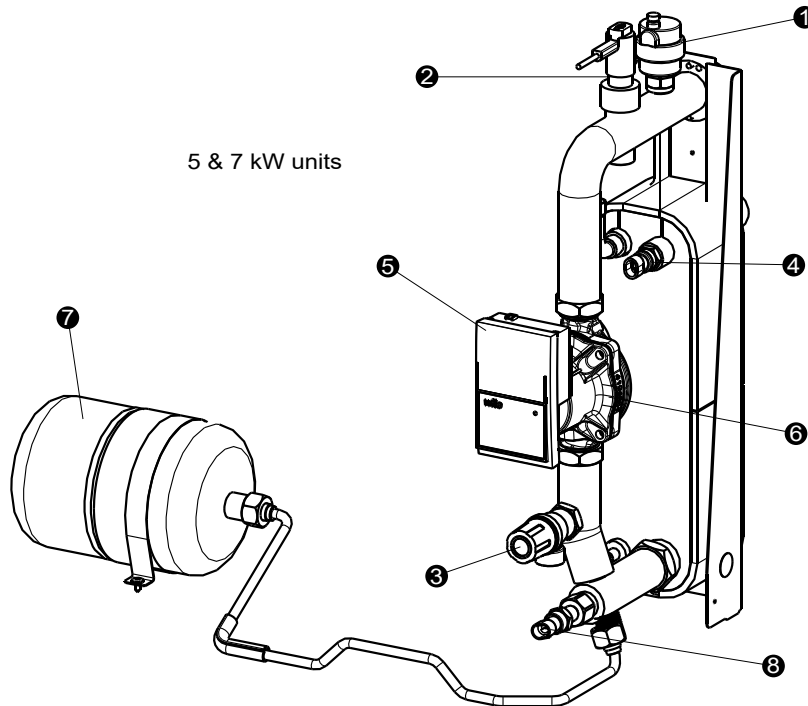

11 & 15 kW units

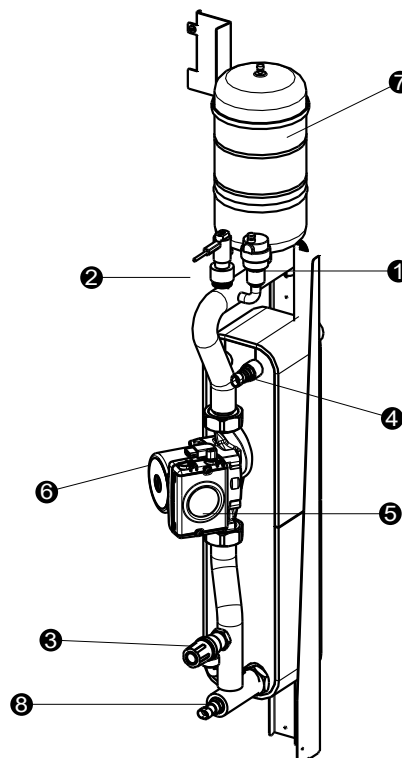

Legend

- ① Automatic purge valve
- ② Flow switch
- ③ Safety valve outlet
- ④ Leaving water temperature probe
- ⑤ Circulating pump
- ⑥ Plug to unblock the seizing pump
- ⑦ Expansion tank
- ⑧ Entering water temperature probe

Schematic installation diagram

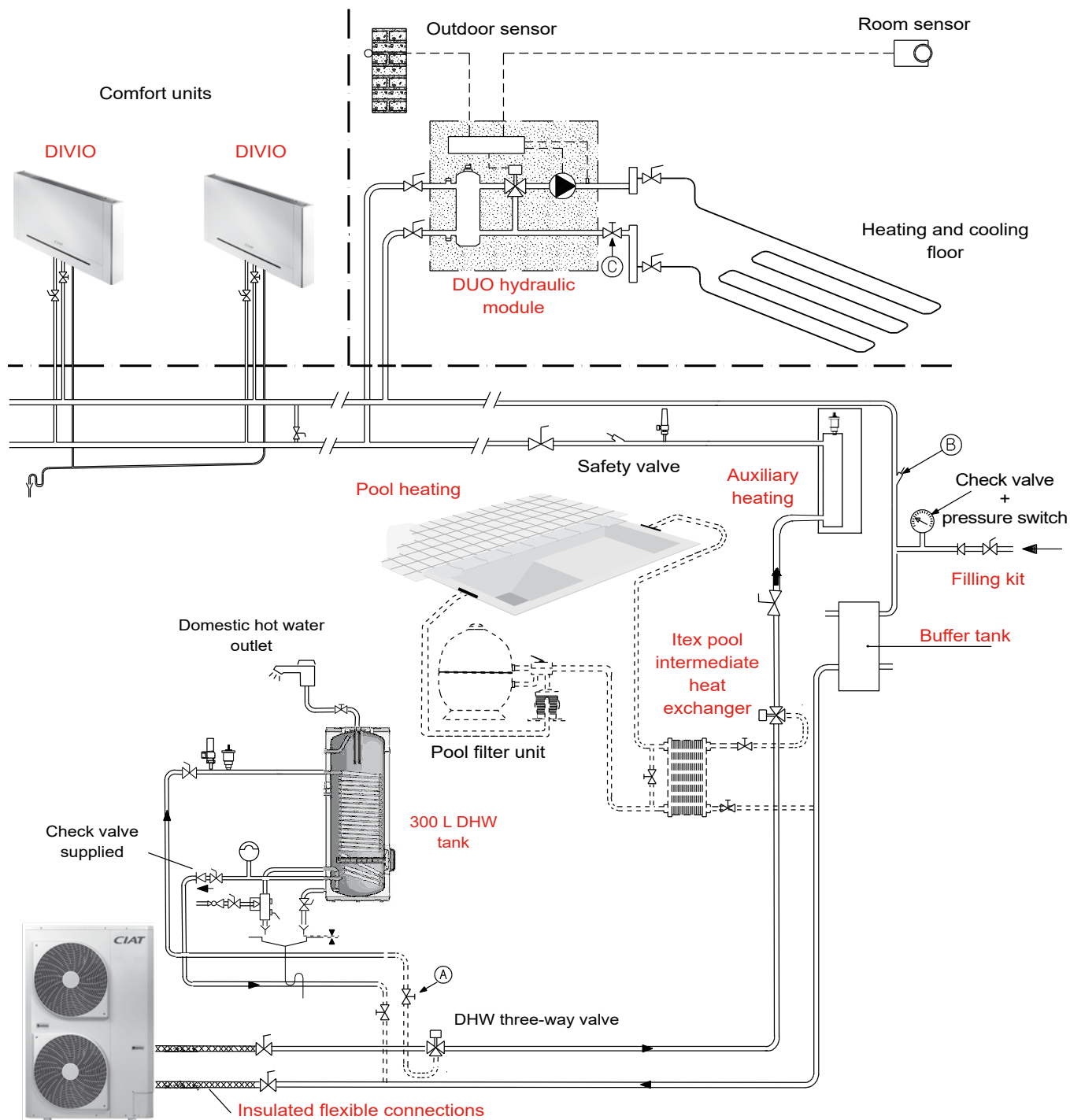

- A** Shut-off valves
- B** Thermometer pockets
- C** Control valves
- Option

Note: the schematic diagrams herein are provided for information only. Under no circumstances do they constitute actual installation diagrams

This document is not legally binding. As part of its continuous drive to improve its equipment, CIAT reserves the right to make any technical modifications without prior notice.
Ref.: NA 19.760A

Head office

700 Avenue Jean Falconnier - B.P. 14
01350 - Culoz - France
Tel.: +33 (0)4 79 42 42 42
Fax: +33 (0)4 79 42 42 10
www.ciat.com



CIAT Service

Technical support: 0 892 05 93 93 (€0.34/min)
Spare parts: 0 826 96 95 94 (€0.15/min)
pdrfrance@ciat.utc.com - PDRGarantie@ciat.fr

