

EN75466664.02

03- 2019

# FLOWWAY ACCESS

Instruction manual  
Manuel d'instructions  
Benutzerhandbuch  
Manual de instrucciones  
Instructiehandboek



<b>CONTENTS</b>	<b>PAGE</b>
1. RECEIPT	3
2. HANDLING	3
3. DESCRIPTION OF THE UNIT & TECHNICAL CHARACTERISTICS	4
4. INSTALLATION & CONNECTIONS	9
5. SYSTEM START-UP	16
6. MAINTENANCE/SERVICE INTERVALS	17
7. PROBLEMS/CAUSES/SOLUTIONS	20
8. TESTS AND GUARANTEES	20



For your safety, we recommend the use of PPE (Personal Protective Equipment)

EN

## 1. RECEIPT

The installation and maintenance operations must be performed by qualified and experienced personnel. This appliance is not designed to be used by persons (including children) with limited physical, sensory or mental capabilities, or by persons with insufficient experience or knowledge, unless they are being supervised by a person responsible for their safety or have received instructions on the use of the appliance from such a person. Children should be supervised to ensure that they do not play with the unit. Follow the operating precautions to the letter when working on the unit. Labels have been placed on the unit to remind you of the safety instructions. As a general rule, follow all applicable safety regulations and standards. Damage to the dual flow air handling unit will be disregarded in the event of failure to follow the instructions in this document.

Each unit has a name plate bearing an identification number. This number must be quoted in all correspondence. In accordance with Article 133-3 of the French Code of Commerce, the recipient is entirely responsible for checking the condition of the goods received. In the event of missing items, the customer must provide the exact number of parcels delivered. Any damaged or missing items must be specified on the delivery note in the presence of the driver before signing the delivery note. This information must be confirmed to the Carrier by registered letter within three business days. The comments "conditional" and "pending unwrapping" shall have no value. The client must unwrap the goods in the presence of the driver. Claims must be made at the time of delivery and be described in detail. The unit must be stored in its packaging and sheltered from weather. The machines are supplied as a single unit.

## 2. HANDLING

The unit can be handled by slings, lifting beam or stacker. In all cases, the lifting point has to be at the base of the unit. The centre of gravity is at the centre of the unit.

**This operation will be performed by qualified personnel.**



The unit must be handled with care, and only in the horizontal position. If the unit is handled by a lifting beam + slings, tubes need to be placed in the holes provided in the support feet.



**Ensure that the crane hook adapter is large enough to prevent the belts applying any pressure to the AHU casing. Furthermore, ensure that the steel tubes are secured to prevent any movement.**



If the above-mentioned lifting methods cannot be used, the unit may be lifted using a forklift truck, taking great care not to dent the lower panel (use forks of a sufficient length).

Follow the applicable handling rules.

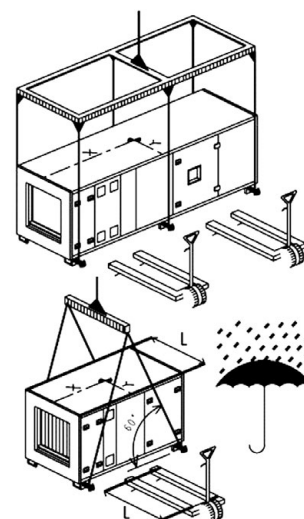

The units must be set down directly on flat, level ground. The flatness value must be the best possible, around one per thousand. Under normal conditions of use, there is no need to fix the unit to the floor, unless it is being installed outside of the building. The unit's support feet must be standing fully on their contact surface. It is important to allow sufficient service space to facilitate maintenance operations.

### 3. DESCRIPTION OF THE UNIT & TECHNICAL CHARACTERISTICS

#### GENERAL INFORMATION

During normal use, this unit is intended to operate under the following site conditions:

- Maximum altitude: 1000 m (please consult us for higher altitudes)
- Minimum and maximum temperatures: -10 °C/+40 °C
- Overvoltage category: III
- Pollution degree: 3

#### DESCRIPTION OF THE UNIT

##### Name plate

This is fixed inside the unit (intake fan section) and shows the unit's specifications as well as the order number and code.

Réf. Produit / Item Ref.		Désignation / Description	
7219278.405377		XXXXXXXXXXXXXXXXXX	
An / Year N. Serie : Serial Nbr	Composant / Composant	Repère / Part	
02380021/0001		CTA 22 FDY	
TENSION / VOLTAGE	ELEC. ELEMENT	BATTERIE FRD	
230/400V 50HZ 2P			
P.ABSORBEE / INPUT	P.ABSORBEE / INPUT	REGIME	
0.75 KW			
INTENSITE / CURRENT	BATTERIE + / HEAT	FLUIDE / FLUID	
POIDS / WEIGHT SERVICE	REGIME	N° Déclaration CE	
182 KG			

##### Pictograms

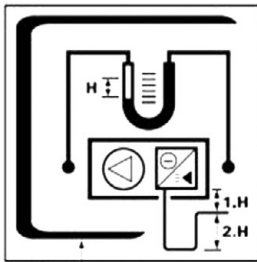

Condensate drain siphon



Monitor the cleanliness of the filters

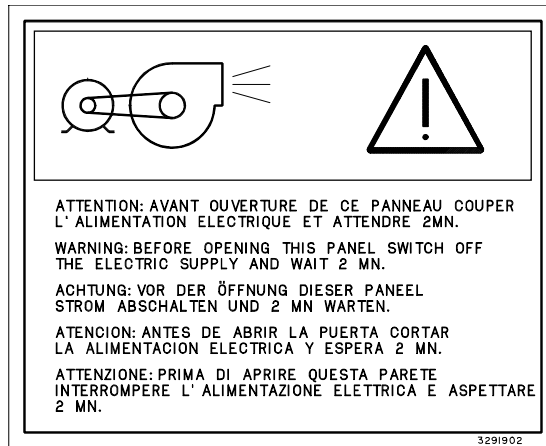

Danger: fan

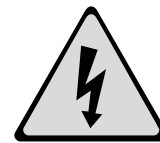

Danger: electrics box

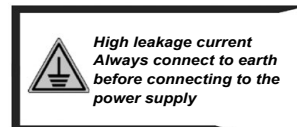

Grounding compulsory

##### Weights and dimensions tables

Sizes	Dimensions (mm)			Total weight (kg) +/- 10%
	Height	Length	Width	
1000	958	1266	810	230
2000	1158	1310	1010	305
3000	1359	1600	1210	470
5000	1659	1600	1510	603
7500	1959	1600	1810	648



The dimensions in the tables above include all the components attached to the casing (hinges, collars, feet).

## LOCATION OF COMPONENTS

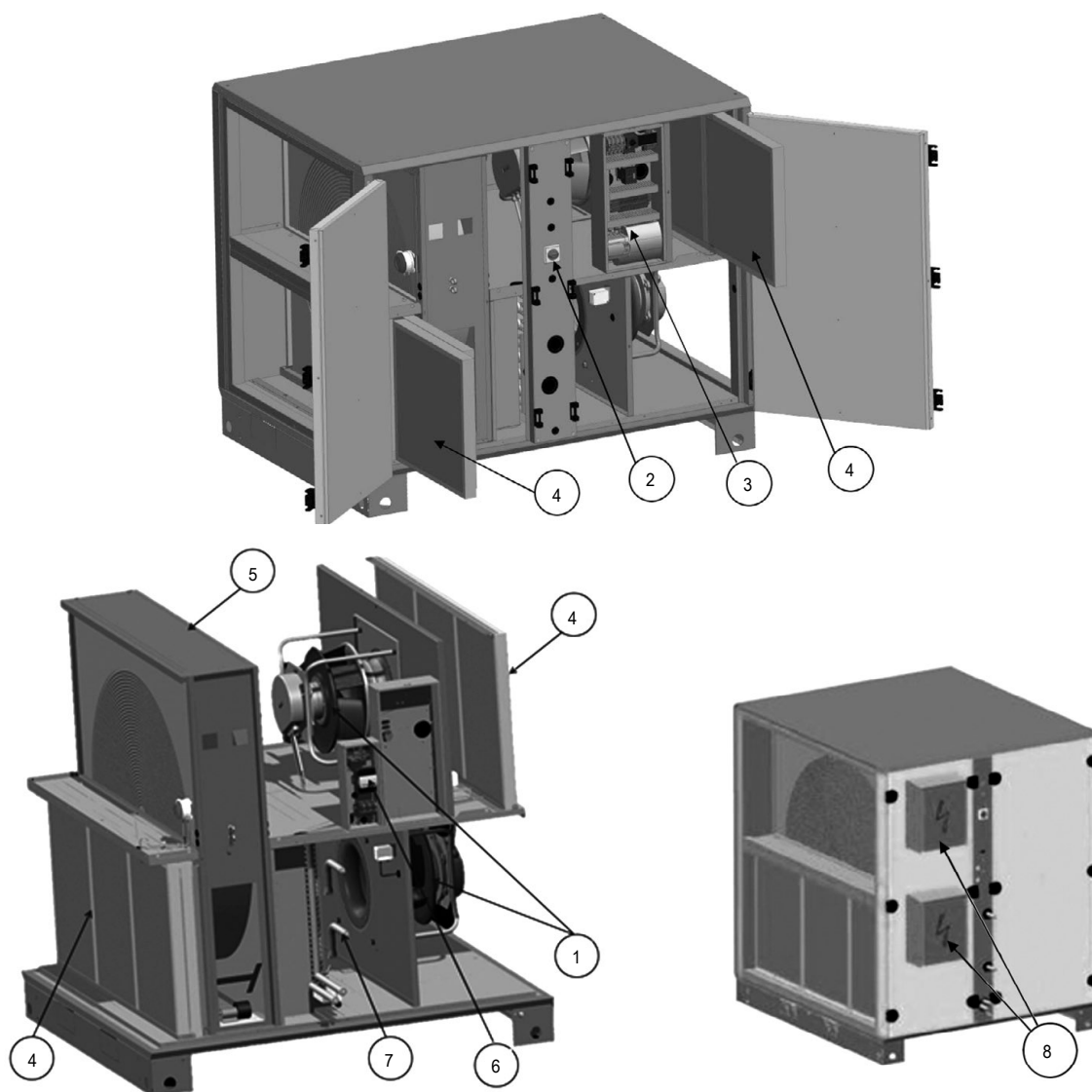

- 1 Fan motor assembly
- 2 General switch (on outer casing)  
Main earth terminal (on inner casing, see p. 12)
- 3 Electrics box
- 4 Filters
- 5 Rotary heat exchanger
- 6 Energy meter enclosure (if present)
- 7 Indoor coil (hydraulic, electric or DX)
- 8 VRF electrics box option

## TECHNICAL CHARACTERISTICS

### Air flow rates

Size	Minimum flow rate m <sup>3</sup> /h		Nominal Flow Rate m <sup>3</sup> /h	Maximum flow rate m <sup>3</sup> /h	
	DX coil	Other coils		Cooling coil (water and DX)	Other coils
1000	580	350	1000	1200	1450
2000	940	500	2000	2500	2800
3000	1500	700*	3000	3700	4500
5000	2600	900	5000	5700	7000
7500	3000	1400	7500	8500	11000

\* 800 if aluminium wheel

Operating limit temperature: -30°C/+ 60°C

**Filters**

**M5 HEE filter**

Thickness: 48 mm  
Fire rating: M1

**F7 HEE filter**

Thickness: 48 mm  
Fire rating: M1

**F9 HEE filter**

Thickness: 48 mm  
Fire rating: M1

**Single filtration**

	Sizes				
	1000	2000	3000	5000	7500
Filter Dimensions x Number of cells/ air flow	(704x327x48) x 1	(452x435x48) x 2	(552x535x48) x 2	(466x685x48) x 3	(566x835x48) x 3

**Dual filtration**

When dual-stage filtration is installed, the two stages of cells are installed on the same runner.

**Recommended fouling level value**

The pressure switches installed enable a filter fouling warning to be issued. They are factory-set, based on:

- the unit size
- the selected flow rate
- the filter efficiency

The graphs below give values which enable the actuation threshold for the pressure switches to be defined based on the selected flow rate.

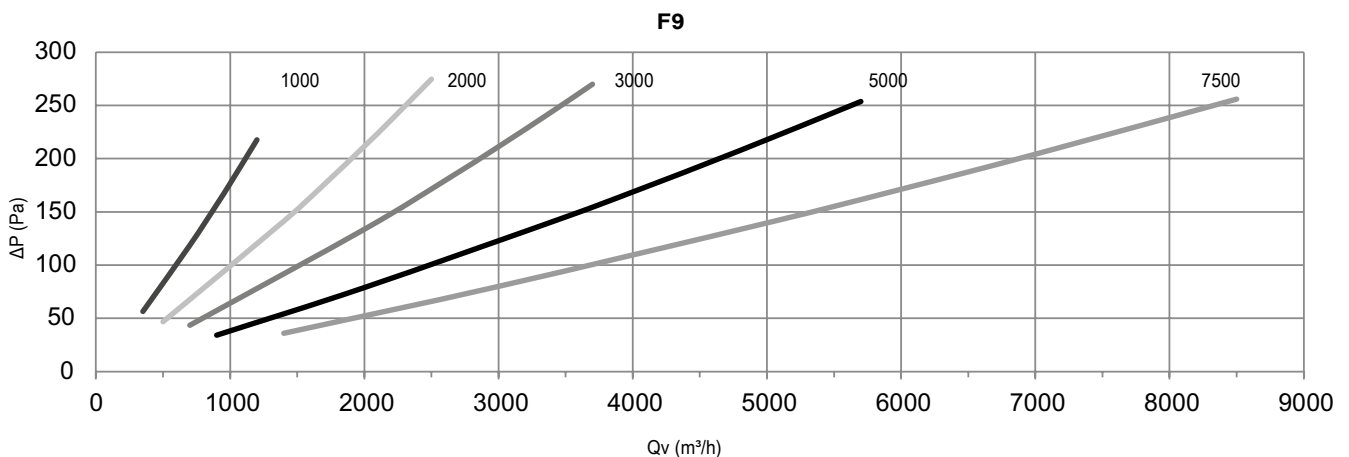
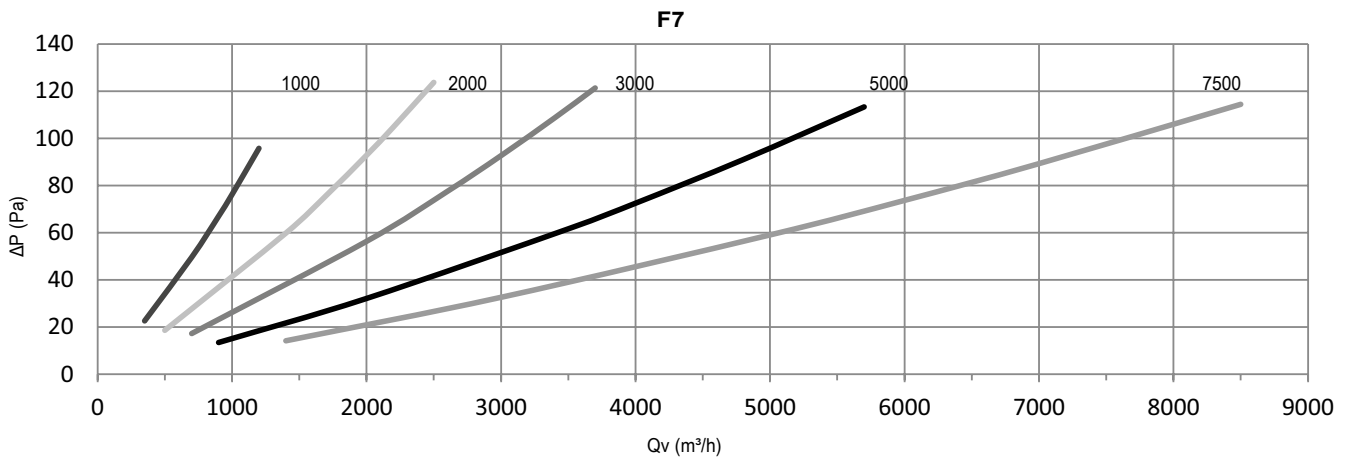
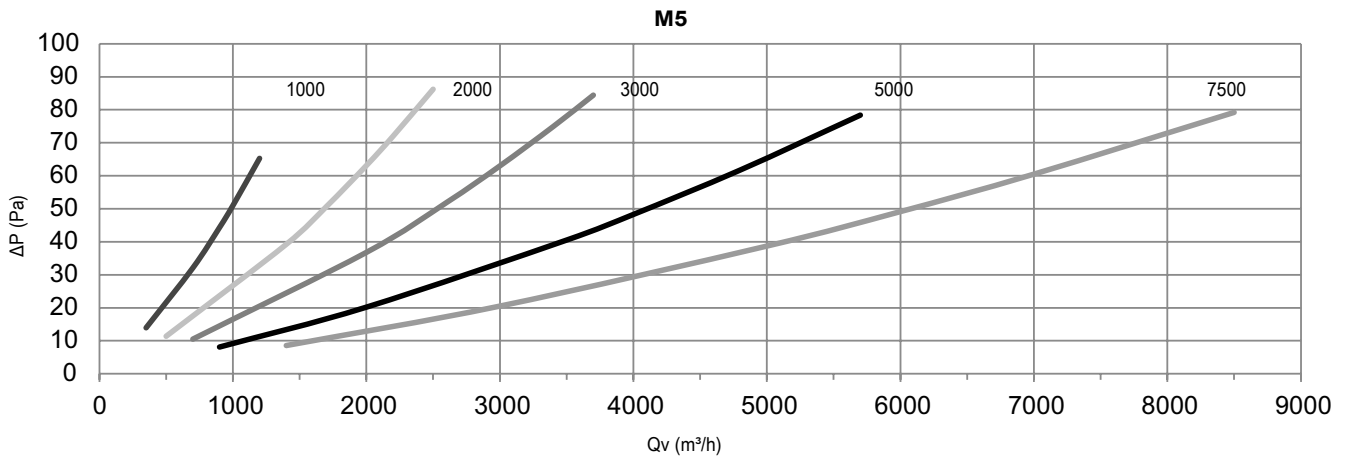

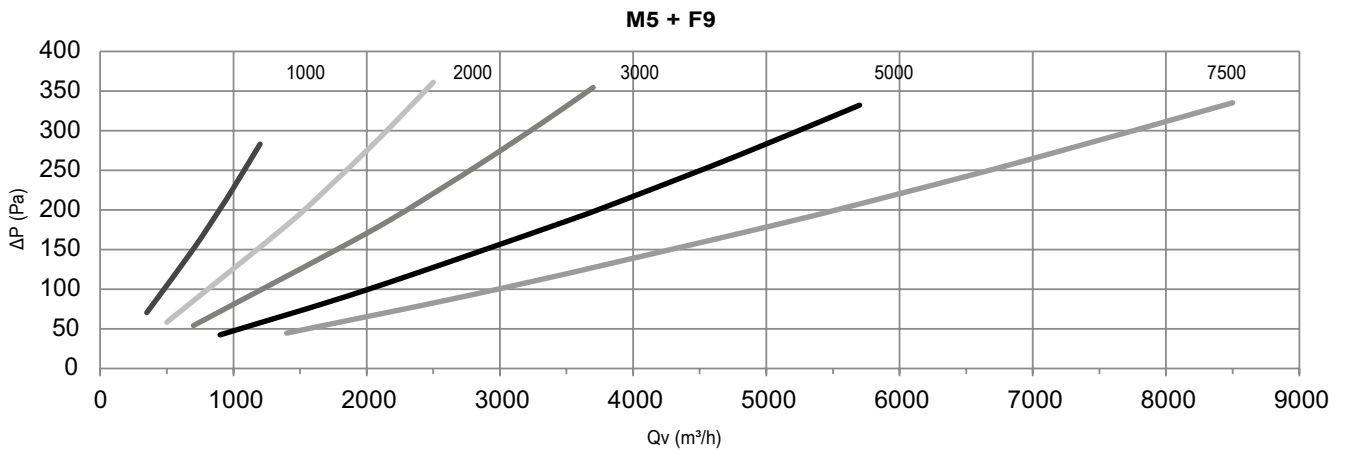
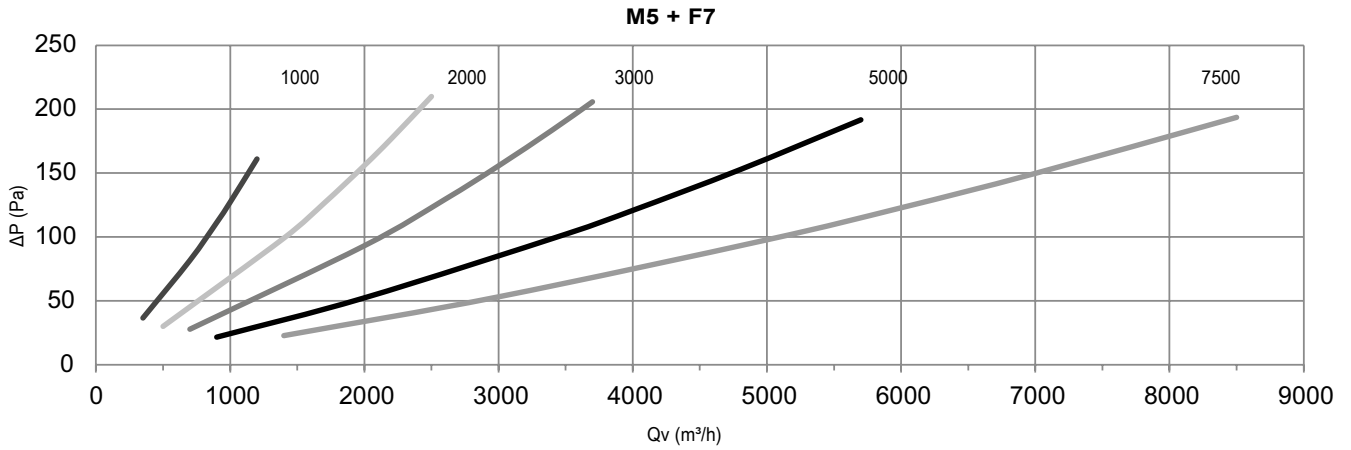

**Fan motor assembly**

**EC motor**

This fan motor assembly is a direct coupling type plug fan.

The unit is equipped with 2 fan motor assemblies: 1 at the intake and 1 at the exhaust. Sizes 1000, 2000 and 3000 are available in an aluminium or polypropylene version; refer to the equipment selection sheet to find out the type of fan used.



**Aluminium wheel**

	Sizes				
	1000	2000	3000	5000	7500
Wheel Ø	250	280	310	355	450
Quantity	2	2	2	2	2
Max. power (W)	2 x 500	2 x 1000	2 x 1800	2 x 2680	2 x 3030
Max. current (A)	2 x 2.2	2 x 1.6	2 x 2.8	2 x 4.1	2 x 4.7

**Polypropylene wheel**

	Sizes		
	1000	2000	3000
Wheel Ø	250	310	400
Quantity	2	2	2
Max. power (W)	2 x 520	2 x 790	2 x 1320
Max. current (A)	2 x 2.3	2 x 1.3	2 x 2.1

**Heat recovery unit**

Constant speed rotary heat exchanger controlled by the unit's control system.

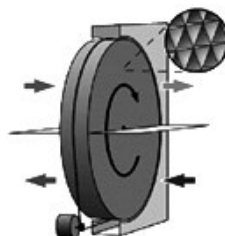

**Options and accessories**

**Support feet and accessories**

To obtain a greater clearance height, fit the adjustable feet (30 to 100 mm) underneath the standard feet.

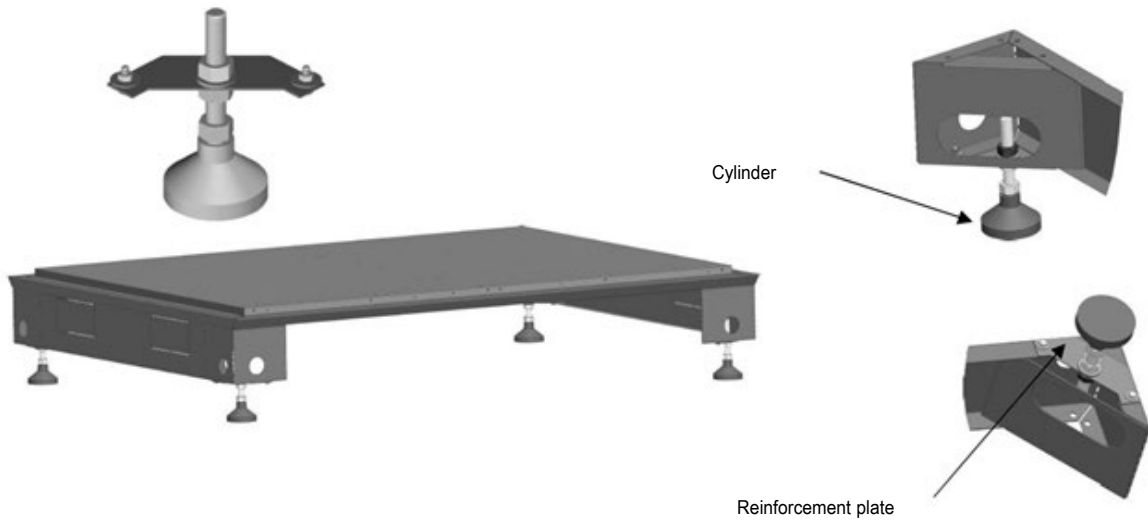

**CO<sub>2</sub> sensor**

The CO<sub>2</sub> sensor must be positioned on the return air duct, so that it can measure the CO<sub>2</sub> level emitted from the part(s) treated. This sensor is supplied as a spare part and the manual for this is included in its packaging.

**Operating principle:**

To configure the CO<sub>2</sub> level activation threshold, refer to the information on air quality for the town/city in which the AHU is installed.

**CO<sub>2</sub> concentration scale and the effects on humans:**

CO <sub>2</sub> concentration	Effect on humans
380 - 480 ppm	Normal atmospheric level
600 - 800 ppm	Correct level for enclosed spaces
1000 - 1100 ppm	Tolerable level for enclosed spaces
5000 ppm	Upper limit for 8 hours of exposure

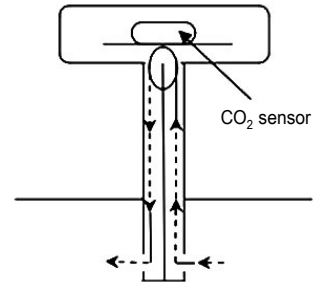

The CO<sub>2</sub> sensor provides an operating range of 0 to 2000 ppm and must be installed in a duct (refer to the attached supplier instructions).

**Constant pressure sensor**

Constant pressure is only controlled on the flow of fresh air being supplied (if the optional constant pressure kit has been purchased).

The fresh air fan is controlled by the signal from this pressure sensor in the duct.

The exhaust air flow is controlled by the flow rate signal read off the flow of fresh air, and may vary according to a factor M (0.5 – 1.5).

Two pressure values can be configured: Nominal pressure and Reduced pressure.

The duct pressure sensor must be positioned on the supply air inlet duct at a distance:

**D = 2 Dh** (hydraulic Ø)

- If the duct is circular, Dh = Ø of the duct
- If the duct is rectangular

$$Dh = \frac{2 \times L \times l}{L+l}$$

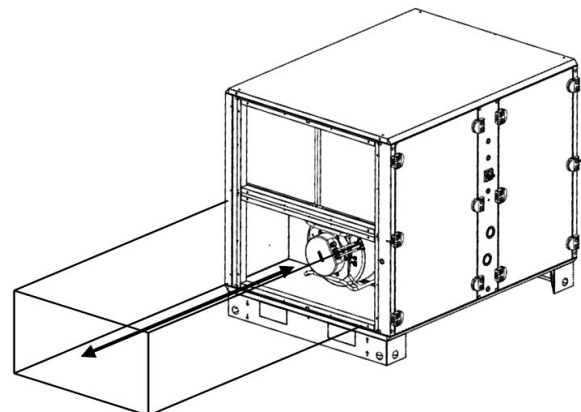



### Changeover thermostat for mixed coil:

The customer is responsible for installation on the hydraulic system. The changeover thermostat installed on the pipe must be integrated into the insulation of the hydraulic pipe.

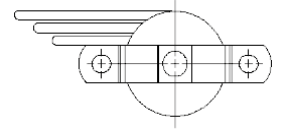

### Technical characteristics

Min. WINTER temp.: 28 °C  
Min. SUMMER temp.: 18 °C  
Breaking capacity: 5(3) A.  
Cable length: 2500 mm

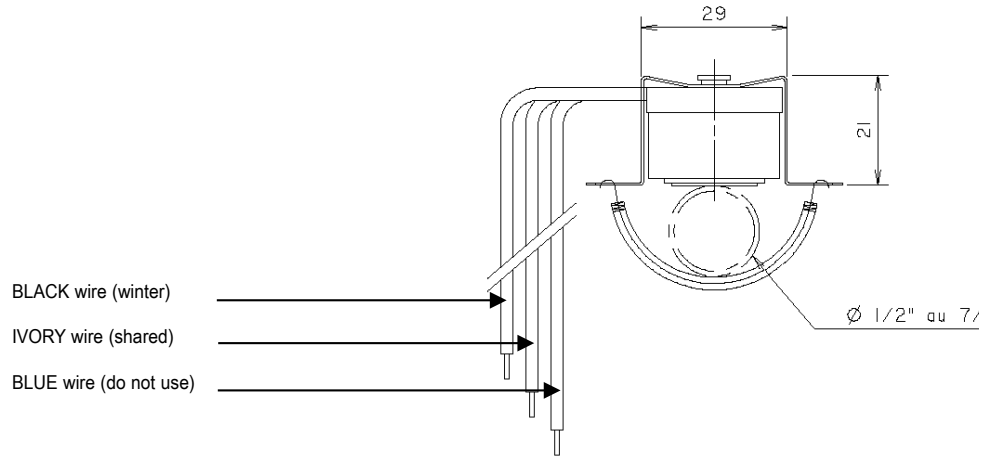

### Damper



The damper is not protected against the weather if the canopy option has not been selected.

## 4. INSTALLATION & CONNECTIONS



The installation of the equipment must comply with the regulations and standards of the recipient country.  
Ensure all electrical components are earthed.  
The equipment must not be accessible to the public.

### Special recommendations:

- Connections must not place mechanical stresses on the unit.
- Keep all inspection doors closed while the unit is operating
- It must not be possible to access the fans via the connection frames for the unit. If there is a direct air intake, a grille must be fitted, as a minimum.
- If fitted outdoors, the units must be installed so as to withstand the climate conditions in the installation location (risk of snow: height from ground/risk of wind: suitable mountings, gooseneck type electric connection to the unit, etc.).

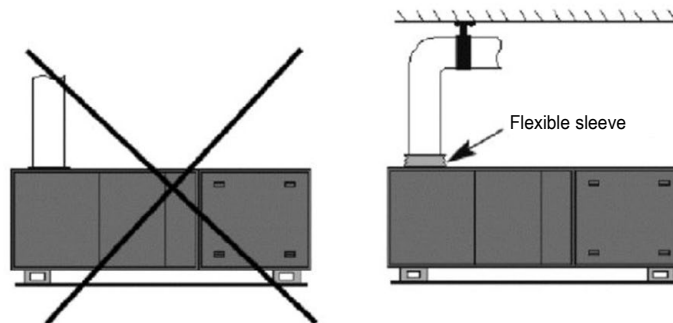

### INSTALLATION OUTDOORS

The installation of a dual-flow unit outdoors requires a roof and a canopy to be fitted; these are usually supplied mounted\* and adapted to suit each configuration.

(\* supplied in kit form if delivery of the elements assembled is not possible)

### Fitting the roofs

The roofs for units are designed to provide sufficient protection against adverse weather conditions, as they overlap the edge of the unit by 80 mm.

**Fitting procedure:**

1. Affix the foam gasket along the length of the unit (50 x 20 foam gasket).
2. Fix the roof panel(s) along the entire length of the unit.

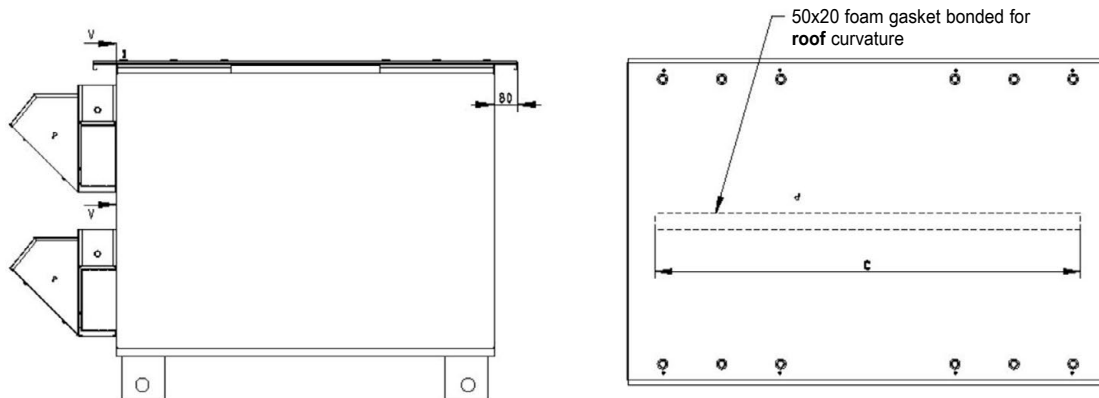

3. Assemble the roof on the unit as per the following diagram

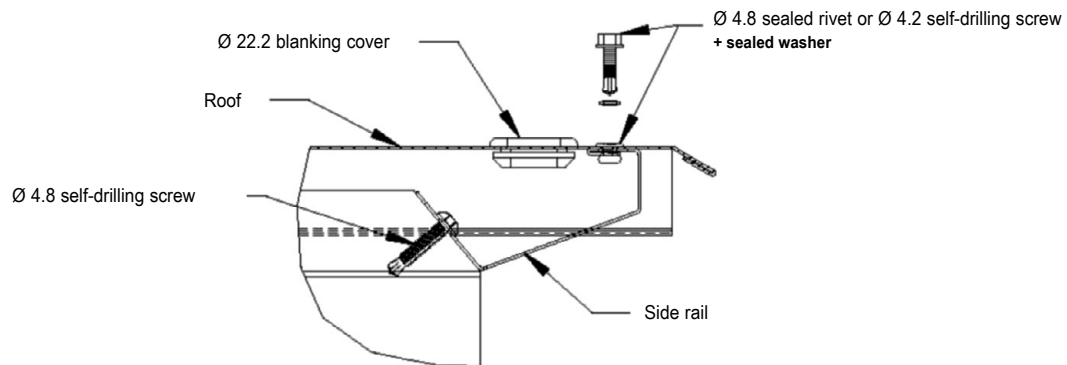

**Fitting the canopy without damper**

The upper panel will be assembled on the two side panels using screws, washers and nuts or sealed rivets. Also fit the protective screen during installation.

Fix a sealing gasket around the edge of the canopy which will be in contact with the unit and apply mastic if necessary.

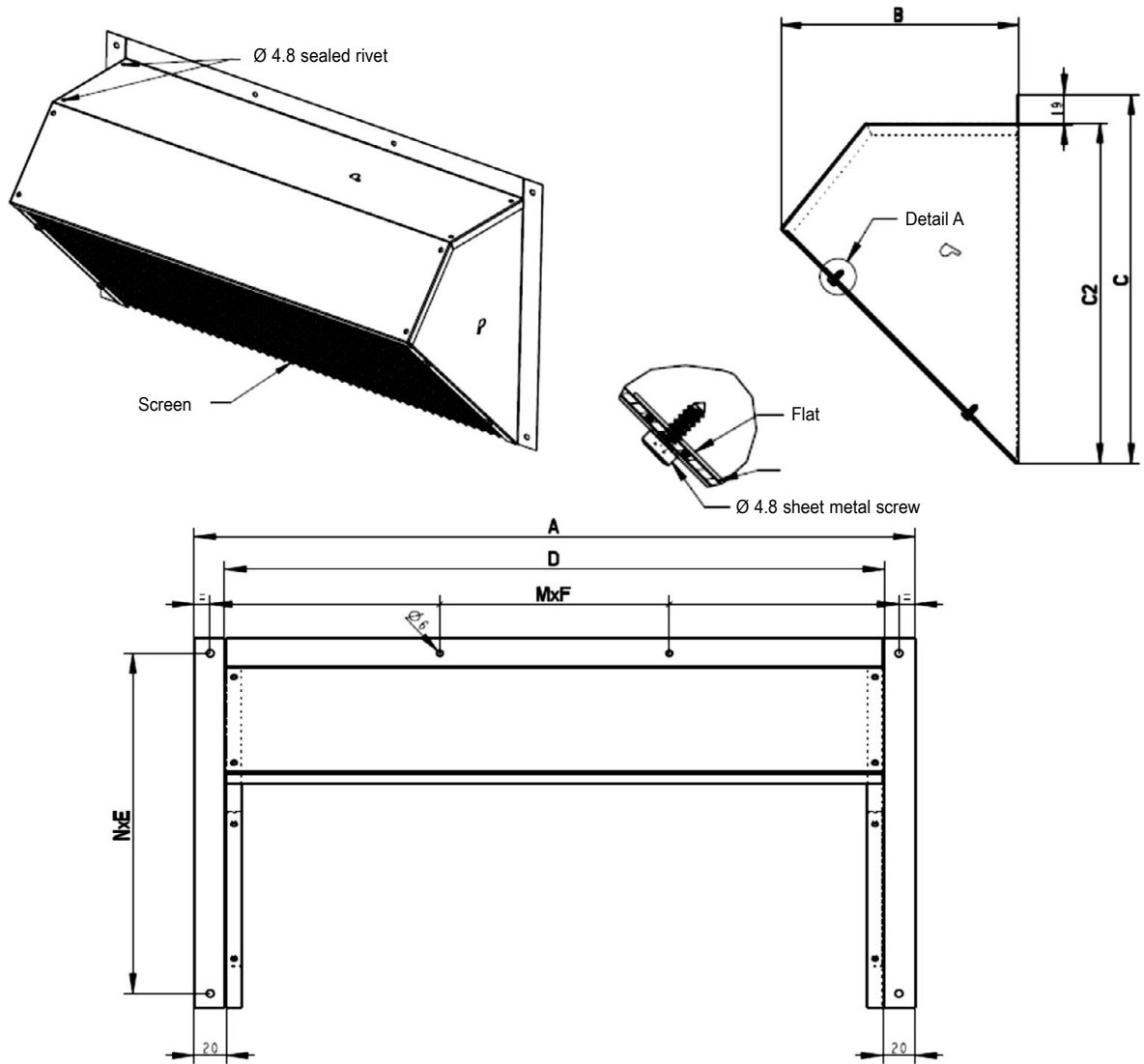

Sizes	A	B	C	C2	D	N x E	M x F	Weight (kg)	Openings
1000	637	274	394	376	598.5	2x190	2x313	2,5	Circular
2000	737	304	494	476	698,5	2x240	2x363	3,4	
3000	1188,5	358	579	560	1150	2x265	3x340	5,3	Rectangular
5000	1488,5	390	669	650	1149	2x310	6x220	6,7	
7500	1788,5	528	869	841	1750	2x405	5x324	12,2	

**CONNECTIONS**

**DIMENSIONS OF AIR FLOW CIRCUITS**

	Sizes				
	1000	2000	3000	5000	7500
Connections (mm) air intake and discharge	Ø 250	Ø 355	458x984	608x1284	758x1584

\* Internal dimensions

**DIMENSION OF THE HYDRAULIC CIRCUITS (Indoor hydraulic coil)**

**VALVE CONNECTION**

**Heating/cooling assembly**

**2-WAY VALVE**

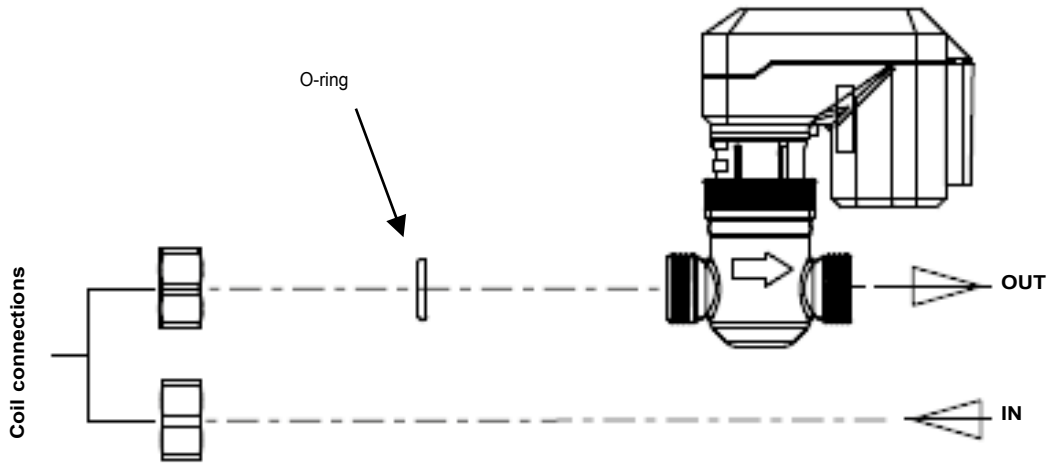

**THREE-WAY VALVE**

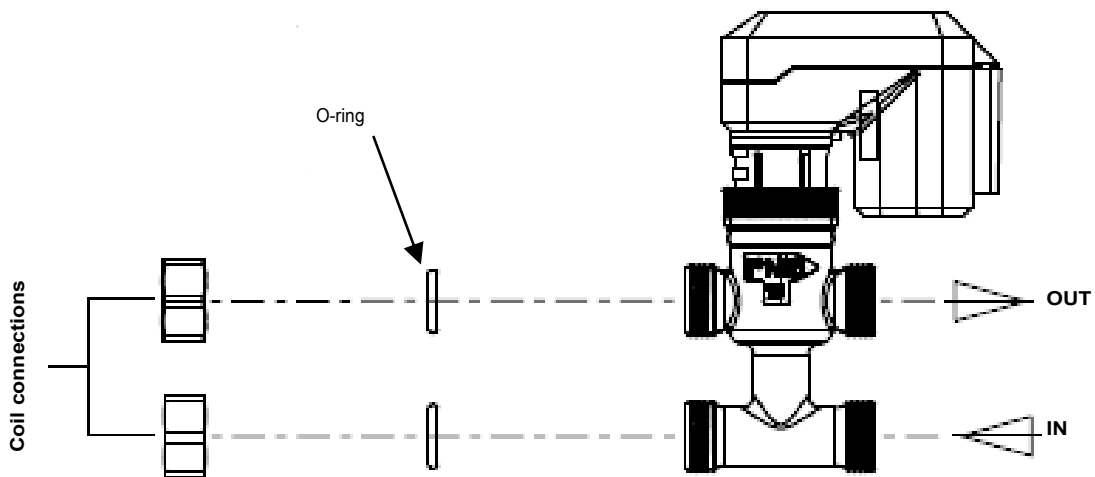

The diameter of the condensate tube on all the pans is 16 mm

1 row coil		Sizes				
		1000	2000	3000	5000	7500
Ø connections (mm) 4-way valve	Valve inlet	G 1/2"	G 1/2"	G 3/4"	G 3/4"	G 1"
	Valve outlet	G 1/2"	G 1/2"	G 3/4"	G 3/4"	G 1 1/2"

2-row coil		Sizes				
		1000	2000	3000	5000	7500
Ø connections (mm) 4-way valve	Valve inlet	G 3/4"	G 3/4"	G 3/4"	G 3/4"	G 1"
	Valve outlet	G 3/4"	G 3/4"	G 3/4"	G 3/4"	G 1 1/2"

## DIMENSION OF THE REFRIGERANT CIRCUITS (Indoor DX coil)

The diameter of the condensate tube on all the pans is 16 mm

2 row coil		Sizes				
		1000	2000	3000	5000	7500
Connection Ø Refrigerating	Liquid inlet	12 mm	12 mm	16 mm	16 mm	2x16 mm
	Gas outlet	16 mm	18 mm	22 mm	28 mm	2x22 mm
	Internal volume (litres)	0.465	0.952	1.49	2.16	3.63

3-4 row coil		Sizes				
		1000	2000	3000	5000	7500
Connection Ø Refrigerating	Liquid inlet	12 mm	12 mm	16 mm	2x22 mm	2x22 mm
	Gas outlet	16 mm	18 mm	28 mm	2x28 mm	2x28 mm
	Internal volume (litres)	0.932	1.91	2.98	4.32	5.24

## ELECTRICAL CONNECTIONS

	Sizes				
	1000	2000	3000	5000	7500
Voltage (V)	230 V 1-Ph	400 V 3-Ph			
Max. current (A) without electric heater	5.4	3.6	6.1	8.8	10.3
Minimum power supply cable section without electric heater	3G1	4G0.75	4G1	4G1.5	4G1.5
Max. current (A) with indoor electric heater	32.4	21.8	33.5	50.6	59.4
Minimum power supply cable section with electric heater	3G6	4G2.5	4G6	4G10	4G10
Disconnect switch size	OT40 (40 A)			OT63 (63 A)	
Max. terminal section (mm <sup>2</sup> )	0.75 to 10			1.5 to 35	
Torque Value (N.m)	0.8			2	

- Connect the unit's electrics to the power network as per the table above.
- Connection to the machine's general disconnect switch located inside it (Ø 22.2 blanking cover provided).
- For sections between 0.75 and 2.5 mm<sup>2</sup>, a H 05 VV-F type cable may be used, otherwise the cable must be type H 07 RN-F.
- The power supply cable must be sized in accordance with current standards and regulations.
- The supply cable must be secured using the anchorage provided (located between the disconnect switch and the Ø 22.2 blanking cover). Once the supply cable has been fed through and connect, tighten the clamp fully and cut the end extending past the clamp.
- Respect the current assigned to the disconnect switch for the air handling unit.
- The leakage current may reach 13 mA. Earthing is essential. Each unit is equipped with 2 earth terminals (PE) indicated by the logo , one close to the disconnect switch, and the other on one of the unit's feet. Both terminals must be permanently connected.

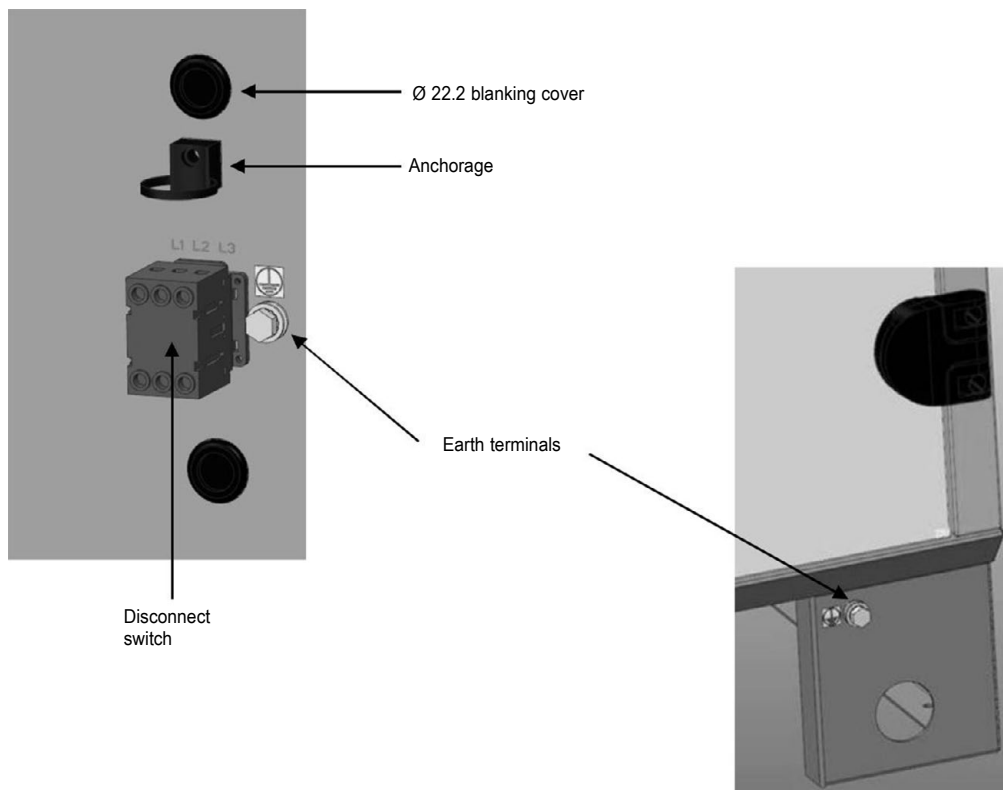

# IDENTIFICATION OF TERMINAL STRIP OPTIONS

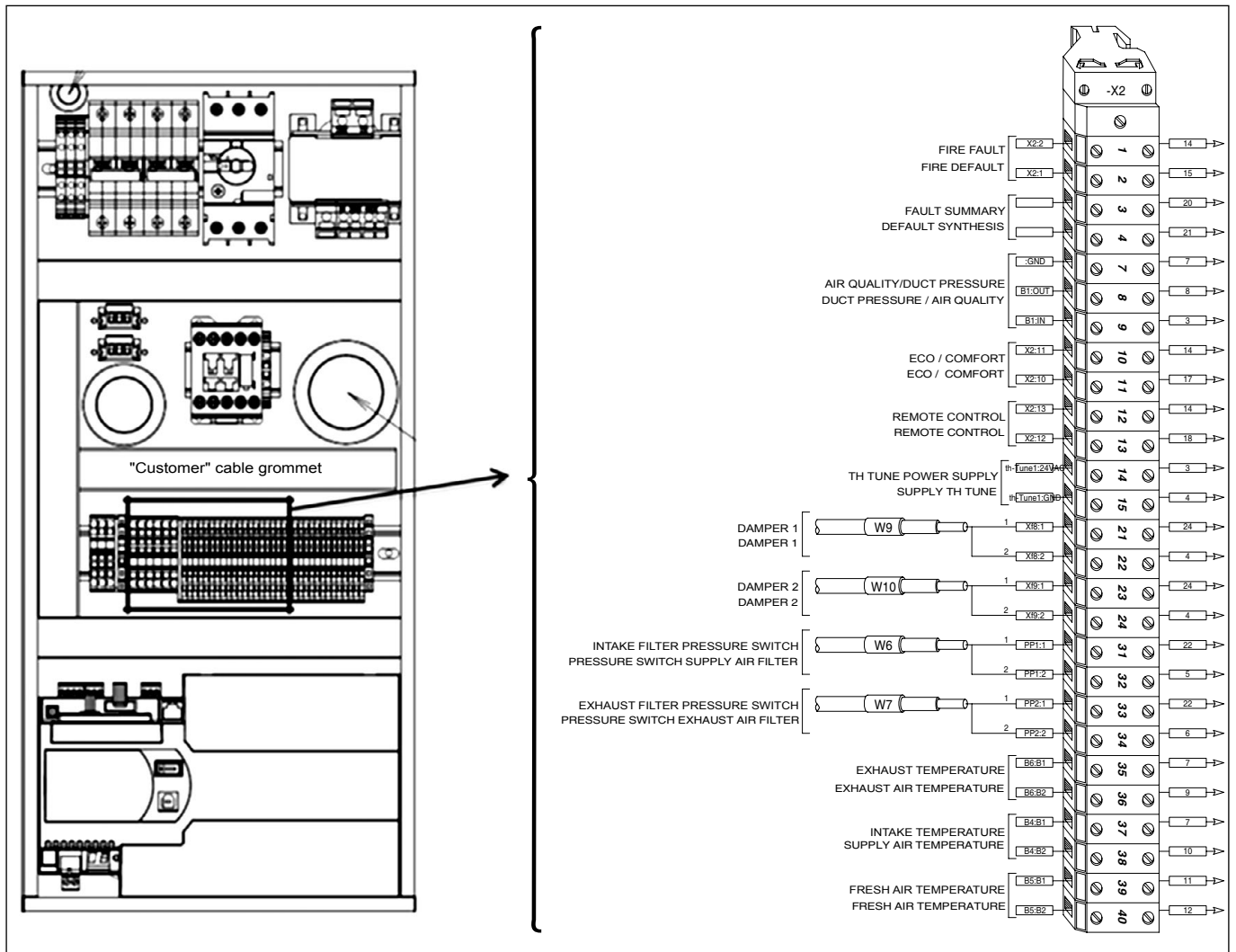

NB: the maximum section of the stripped wire is Ø 1.5 mm and Ø 0.5 mm for a wire with an end-piece.\*

■ **Fire detection: 2 wires**

Machine terminal block	Notes	Inlet/Outlet
X2_b-1	Fire detection activation Dry contact	Digital inputs
X2_b-2		

Contact normally closed

■ **Fault feedback: 2 wires**

Machine terminal block	Notes	Inlet/Outlet
X2_b-3	Fault summary Dry contact (shared b-4) Common	Digital outputs
X2_b-4		

■ **Constant intake duct pressure sensor/IAQ control sensor: 3 wires**

Machine terminal block	Notes	Inlet/Outlet
X2_b-7	Fire detection activation	Analogue inputs
X2_b-8	0-10V pressure control signal (OUT) or <b>Sensor/ Transmitter</b> rear probe 0-10V active sensor	
X2_b-9	Sensor 24V supply	

**CO<sub>2</sub> in duct: CO112-ANA**

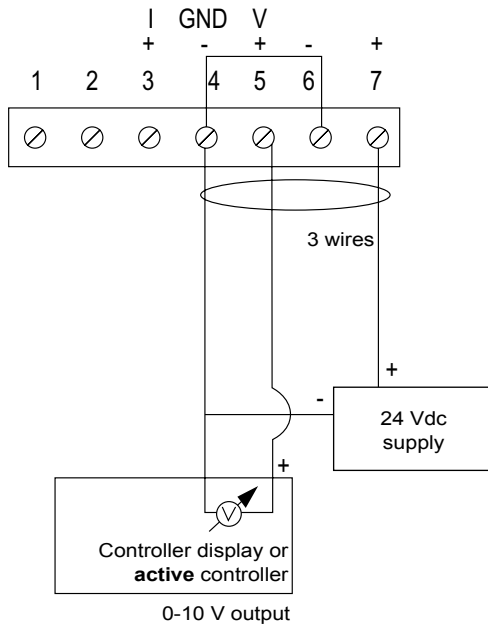

**Duct pressure: CP51**

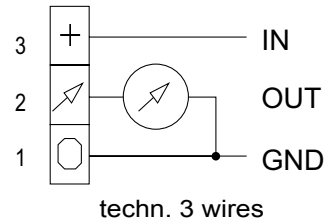

EN

■ **Eco/Comfort contact: 2 wires**

Machine terminal block	Notes	Inlet/Outlet
X2_b-10	Eco/Comfort mode control Dry contact (shared b-10)	Digital inputs
X2_b-11		

■ **Remote On/Off: 2 wires**

Machine terminal block	Notes	Inlet/Outlet
X2_b-12	Unit ON/OFF monitoring Dry contact (shared b-12)	Digital inputs
X2_b-13		

■ **Th-Tune power supply: 2 wires**

Machine terminal block	Notes	Inlet/Outlet
X2_b-14	24V power supply	pLAN
X2_b-15	Ground	

■ **Presence of changeover coil: 2 wires**

Machine terminal block	Notes	Inlet/Outlet
X2_b-16	C/O thermostat black wire	Digital inputs
X2_b-17	C/O thermostat white wire	

The changeover thermostat must be positioned on the "customer" hydraulic pipe, on the "fluid entering the coil" side (so as to be in the insulation).

Contact open: normal operation in cooling mode

Contact closed: operation in heating mode (contact closed from 28 °C)

## INSTALLING THE SIPHON

It is important to ensure the siphon is correctly fitted, as per the diagram below. For a depression H in the condensate drain, the sizing of the siphon must incorporate dimensions of 2H

### Schematic diagram of siphon

#### Assembly with depression :

Z: X+Y+tubing diameter + insulation thickness

Y :  $Y = 0.5 \times X$

X: X = 25 mm for each 250 Pa of negative static pressure + 25 mm

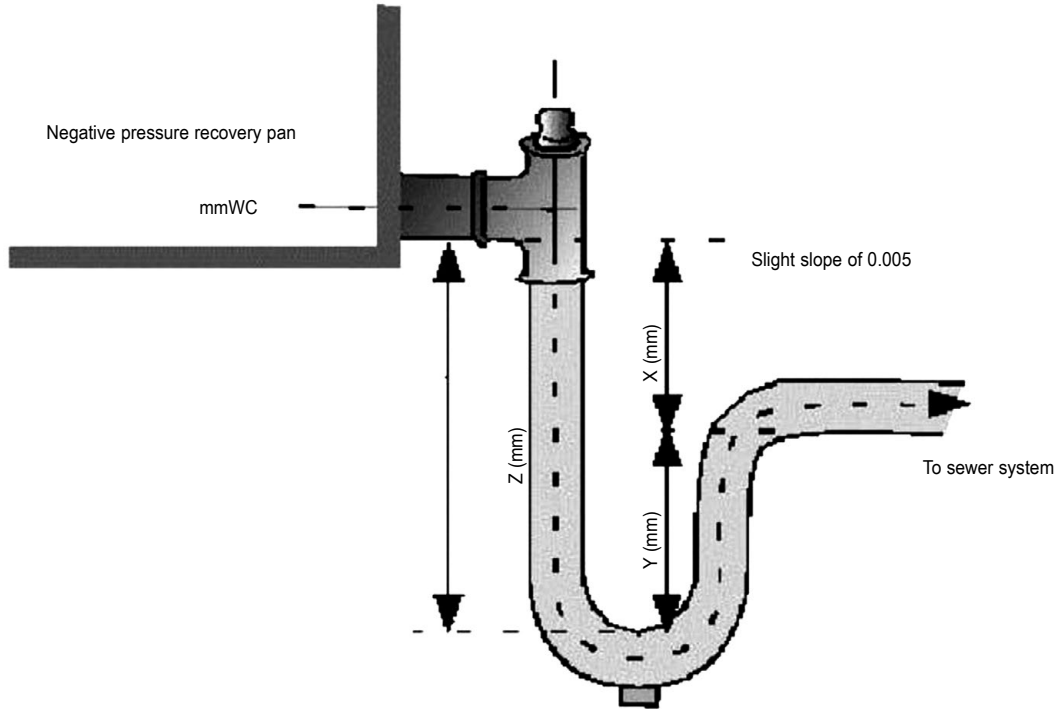

## 5. SYSTEM START-UP



**Commissioning must be performed by qualified personnel, trained in air handling technology. Keep all inspection doors closed while the unit is operating.**

Once the electrical, hydraulic and refrigerating connections have been carried out, proceed with system start-up for the unit, checking the steps below:

- For units with DX coil, the refrigerating machine must be operational (system start-up of the refrigerating machine not provided by CIAT).
- Check the tightness of all connections,
- Make sure that the inside of the unit is clean, and that there are no foreign bodies inside it,
- Check the wiring
- Check the electrical supply voltage and the ratings of the overload protections against the current ratings of each component,
- To configure the setpoints, refer to the control system manual,
- Simulate activation of the various electric components, controlled components and alarms,
- Check the currents:
  - Temperature alarm,
  - Air flow alarm,
  - Fan motor assembly
- Check the air flow rates
- After a few hours' operation, check the filter fouling condition.

### **CONTROL**

For adjustment and configuration of the control system, refer to the corresponding manual provided with the unit.



## 6. MAINTENANCE/SERVICE INTERVALS



Switch off the electrical supply to the air handling unit before carrying out any work

### **Details of hinges/handles: Allen key locks, size 4**

When they are unlocked, the handles are in "hinge" mode. It is possible to unlock a single row of handles to open like a conventional door. If all of the handles are unlocked, the door can be removed.

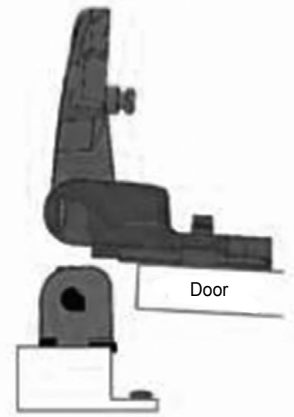
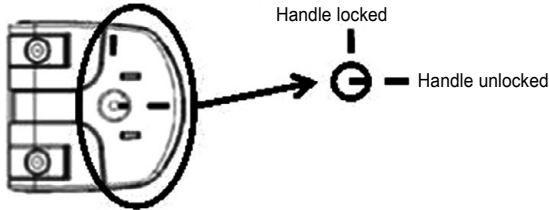

### **FILTERS**

After commissioning, the speed of filter fouling will depend on the care taken when cleaning the air flow circuits. Hence the frequency of filter checks should be increased during this period.

#### **Maintenance intervals**

The filter life depends essentially on the amount of dust in the air and the efficiency of the filtration system. The filtration quality cannot be maintained if the filter medium has been damaged during maintenance. We recommend that the filters be replaced once every two years, even in the case of moderate use

#### **Filter replacement method**

During filter maintenance operations, it is important not to spread the dust that has accumulated in the filters.

Turn off the unit.

Access the filters by opening the door panels.

Simply pull on the filters.

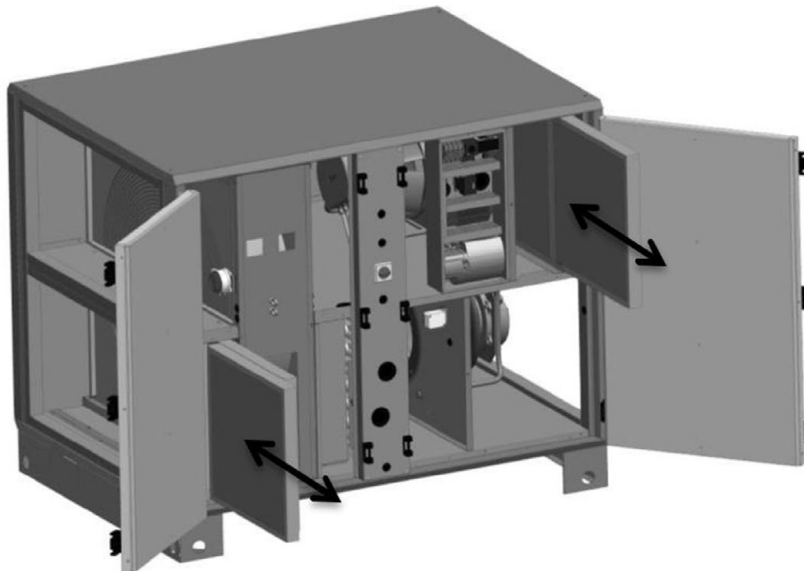

### **FAN MOTOR ASSEMBLY**

Check and retighten the electrical connections once a year.

#### **Intake FMA removal method**

1. Open the door
2. Release the 4 x M8 screws
3. Disconnect the motor's electrical connections
4. Take out the FMA

## Exhaust FMA removal method

1. Open the door



2. Remove the upper and lower fixings from the electric box



3. Move the electric box; a sufficient length of cable is provided



4. Disconnect the various quick connectors



5. Provide sufficient clearance



6. Remove the 4 x M8 screws



7. Disconnect the motor's electrical connections

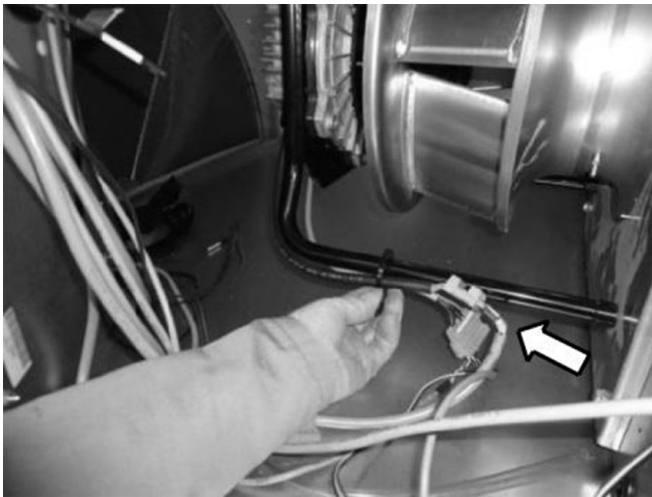

8. Take out the FMA



To refit, perform the operations in reverse order.  
Check that the box and the connectors are secure before commissioning.

**HEAT RECOVERY UNIT**

**Rotary heat exchangers**

Check the rotation speed once a year.  
When stationary, the rotary heat exchangers accumulate dust and moisture at their lowest point.  
Schedule cleaning during prolonged stoppages.  
Check the permanently lubricated bearings once a year.

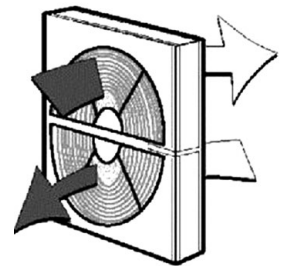

**Wheel consumption**

		Sizes				
		1000	2000	3000	5000	7500
Constant speed	Power (W)	25	25	40	90	180
	Voltage (V)	230 V 1-Ph			400 V 3-Ph	

**ELECTRICS BOX**

Retighten the connections twice a year.  
Visually inspect the components, wires and cables.

**ELECTRIC HEATERS**

The electric heater requires very little maintenance. However, the following checks are necessary:  
Visually inspect the heating elements, wires and connection cables after every 1500 hours of operation.  
Check and retighten the connections once or twice a year.

**HYDRAULIC COILS**

The hydraulic coil requires very little maintenance as it is protected by the filter.

**DX COIL**

The DX coil requires very little maintenance as it is protected by the filter.

**SERVICE INTERVALS**

Regular maintenance will keep the unit running at optimum performance. The values given in the table below are provided for guidance only. They do not take into account individual factors that can lengthen or shorten the unit's service life.

## 7. PROBLEMS/CAUSES/SOLUTIONS

Also refer to the control manual.

Components	At commissioning	2 to 3 months	12 months	Operating readings
<b>Filters</b>		Check the fouling level and replace if necessary	Replace	
<b>Fans</b>	Check the connections		Retighten the connections	
<b>Electrics box</b>	Check the connections	Operating check	Retighten the electrical connections Check the components Operating check	
<b>Pressure/temperature sensor</b>	Check correct operation and setpoint adjustment	Check correct operation and setpoint adjustment	Check correct operation and setpoint adjustment	
<b>Condensate drain pan</b>		Clean with water and a non-abrasive detergent	Clean with water and a non-abrasive detergent	
<b>Refrigerant circuit (if DX coil)</b>	Refer to the instruction manual for the outdoor unit			

## 8. TESTS AND GUARANTEES

To guarantee the product's quality, each air handling unit undergoes a variety of tests: EMC (electromagnetic compatibility) test, component functional tests (fan motor assembly, heat recovery unit, sensor, etc.).

However, our units are guaranteed for a period of 12 months from the commissioning date, when this date occurs within three months of the invoice date.

It is effective for a period of 15 months from the unit invoice date in all other cases.

CIAT's guarantee on motors is limited to the terms of guarantee extended by its supplier.

Under no circumstances must the fitter carry out work on the motor. This will invalidate any future claims on the warranty.

**Note:** for further information, refer to the application of the manufacturer warranty.









**Head office**

Avenue Jean Falconnier B.P. 14  
01350 Culoz - France  
Tel.: +33 (0)4 79 42 42 42  
Fax: +33 (0)4 79 42 42 10  
[www.ciat.com](http://www.ciat.com)

Compagnie Industrielle  
d'Applications Thermiques  
Corporation with a capital of €26,728,480  
Bourg-en-Bresse Register of Trade and Companies  
no. B 545.620.114



ISO9001 • ISO14001  
OHSAS 18001

**CIAT Service**

[www.ciat.com](http://www.ciat.com)

Non-contractual document.

As part of our continuous drive to improve our products, CIAT reserves the right to make any technical modifications without prior notice.

