

Aquair BCP

Installation
Operation
Commissioning
Maintenance



Contents

1. Introduction.....	5
2. Operating limits.....	5
3. Operation mode.....	5
4. Technical characteristics.....	6
5. Transport	7
6. Unit identification	7
7. Safety recommendations.....	7
8. Location and assembly.....	8
Choosing the installation site	8
Anchorage for antivibrators	9
Minimum necessary space for the commissioning and maintenance	10
9. Checking before commissioning	11
Electrical connections	11
Air ducts connections.....	11
Checks in the centrifugal fans	11
Condensates drain connection.....	12
Hydraulic connections	13
10. Optionals	14
Hot water coil	14
Electrical heater	14
Mixing boxes for enthalpic free-cooling	14
Manual external air intake damper.....	14
Remote condensation	15
11. Safety devices	21
12. Commissioning.....	22
Operating temperature of the pool	22
13. Components distribution.....	23
14. Maintenance.....	24
Access to discharge fan:	24
Access to return fan (optional):	24
Access to water condenser	25
Access to electrical panel.....	25
Access to condensates drain pan	25
Air filter extraction	25
15. Control and analysis of breakdowns.....	26



Pool air handling units



1. INTRODUCTION

Aquair BCP series are dehumidification units by cooling circuit, with total heating recovery of condensation, designed for conventional covered pools and other dehumidification applications.

These units are designed for indoor installations; optionally for outdoor installations.

The units are all loaded of refrigerant and are factory tested after their manufacture, checking the correct operation of all their components.

The actions and safety rules to follow for a correct manipulation of the unit are described in this manual.

2. OPERATING LIMITS

Air inlet dry temperature

- Maximum: 35°C (65% RH - 29°C WB)
- Minimum: 18°C (90% RH - 17°C WB)

Condenser water inlet temperature

- Maximum: 50°C
- Minimum: 20°C

3. OPERATION MODE

Aquair BCP units consist of two or three dehumidification stages by two or three cooling circuits:

- one of the circuits condensates on a plates exchanger of SMO 254 chromium and molybdenum alloyed steel, with high resistance against corrosion in presence of chlorides, which recovers part of the energy consumed in the evaporation process.
- the other circuit(s) condensates on an air coil installed at the outlet of air from evaporator, heating the cold and dry air from it, before discharging it to the optional hot water coil.

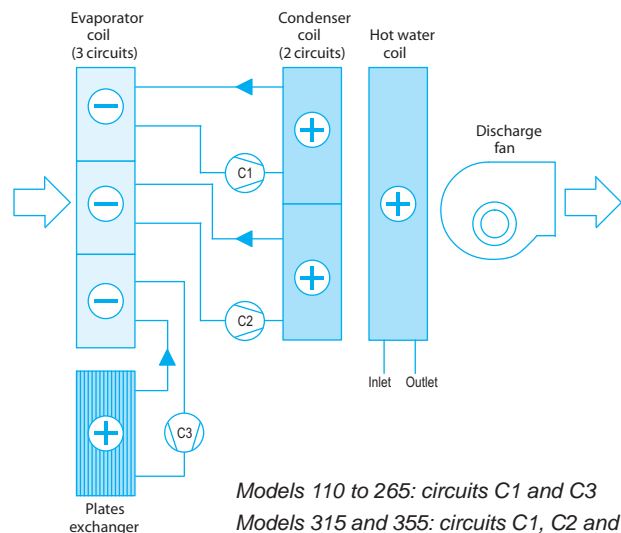

4. TECHNICAL CHARACTERISTICS

Aquair BCP		110	140	180	230	265	315	355	
Air circuit	Dehumidification capacity ① (kg/h)	21,7	27,3	36,1	44,6	53,4	65,5	74,4	
	Heating capacity (kW)	27,5	30,1	42,0	55,0	63,4	69,5	85,2	
	Cooling capacity ② (kW)	31,6	39,7	53,3	67,3	77,1	95,2	108,2	
	Power input ③ (kW)	7,0	8,8	12,4	15,6	18,5	22,9	25,6	
	Nominal air flow(m3/h)	5.500	7.000	9.000	11.500	13.250	16.000	16.000	
	Maximum air flow (m3/h)	6.600	8.400	10.800	13.800	15.900	19.200	19.200	
	Avail. static pressure (mm.w.c.)	15	15	15	15	15	15	15	
	Fan type / Number	Centrifugal / 1							
	Power (kW)	1,1	1,5	2,2	3,0	4,0	5,5	5,5	
High flow air circuit (optional)	Nominal air flow (m ³ /h)	10.500	10.500	17.250	17.250	24.000	24.000	24.000	
	Available static pressure (mm.w.c)	15	15	15	15	15	15	15	
	Fan type / Number	Centrifugal / 1							
	Power(kW)	3,0	3,0	5,5	5,5	7,5	7,5	7,5	
Water condenser	Heating capacity ④ (kW)	10	16,9	20,7	24,9	28,2	43,1	43,1	
	Nominal water flow (m3/h)	1,73	2,92	3,57	4,30	4,86	7,45	7,45	
	Pressure drop (m.w.c.)	4,4	3,2	4,7	3,9	5,0	4,6	4,6	
	Hydraulic connections	1"	1 1/4"	1 1/4"	1 1/2"	1 1/2"	1 1/2"	1 1/2"	
Hot water coil (optional)	Heating capacity ⑤ (kW)	61,5	71,5	90,0	105,0	129,0	145,0	145,0	
	Nominal water flow (m3/h)	3,2	3,7	4,7	5,5	6,7	7,5	7,5	
	Pressure drop (m.w.c.)	2,3	3,1	1,4	1,8	2,1	2,6	2,6	
	Hydraulic connections	1 1/4"	1 1/4"	1 1/2"	1 1/2"	1 1/2"	1 1/2"	1 1/2"	
Compressor	Type	Scroll							
	Compressors / stages number	2					3		
	Air circuit / recovery circuit number	1 / 1					2 / 1		
	Oil volume (l)	1,7 / 1,0	3,3 / 1,4	3,3 / 1,7	4 / 1,7	6,2 / 1,7	3,3+1,7 / 3,3	3,3 x 2 / 3,3	
Power supply	400 V / III ph / 50 Hz (±10%)		3 Wires + Ground + Neutral						
Maximum absorbed current (A)	37,7	31,6	48,0	55,9	61,0	86,6	98,6		
Refrigerant	Type	R-407C							
	Global warming potential (GWP) ⑥	1774							
	Charge (kg)	7,4	8,6	14,7	15,5	17,8	16,9	18,2	
	Environment impact (tCO ₂ eq)	13,1	15,3	26,1	27,5	31,6	30,0	32,3	
Dimensions	Length (mm)	2.070	2.070	2.282	2.282	2.450	2.450	2.450	
	Width (mm)	1.248	1.248	1.498	1.498	1.498	1.498	1.498	
	Height (mm)	1.315	1.315	1.613	1.613	1.813	1.813	1.813	
Weight	(kg)	630	665	895	920	1080	1155	1175	
Condensate outlet Ø	3/4" adaptor								

① Unit cooling dehumidification capacity. For unit selection, it should be taken into account the dehumidification which provides fresh air of ventilation (UNE 100011).

② Cooling capacity for air inlet temperature conditions of 28°C and 65% RH

③ Total power input by compressor and motorfans under nominal conditions.

④ Heating capacity for recovery circuit water 28 / 33°C.

⑤ Water from boiler for hot water coil 82 / 65°C and air inlet at 20°C.

⑥ Climate warming potential of one kg of greenhouse-effect fluored gas relative to one kilogram of carbon dioxide over a period of 100 years.



Pool air handling units

5. TRANSPORT

Aquair BCP units are modular construction units. Their composition range from one module for the standard unit to three modules including all the options.

The modules should be handled with care in order to avoid damages in its transport. For this reason it is advisable:

- Use appropriate transports according to the dimensions of these units until the installation site.
- For transport in container, it should be used those containers with an easy loading/unloading to the installation site.
- Do not remove the unit from its packing until it has been transported to its final location.
- Transport the different modules by a lifting slings only applied to the lifting holes of the unit. Each module has two spars on the base with two flanges each one (solidly screwed) in order to make easy the transport and the lifting by the crane.

Make sure slings are perfectly screwed up before hook them on the flanges.

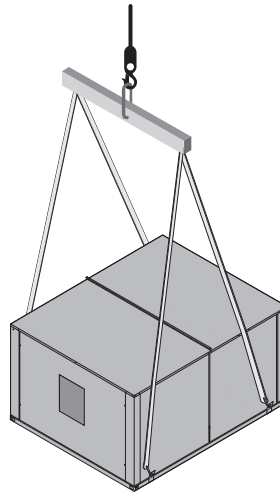

The slings should be separated by a crossbar to avoid damaging the casing.

After positioning the unit, it is suggested to unclamp the flanges, to facilitate the maintenance. Assemble again if transporting the unit.

Flange detail:



- When the different modules are in their definitive location, just by fastening these modules the unit is assembled, without making no type of weld.

6. UNIT IDENTIFICATION

Each unit has a nameplate located on a visible place, in a readable and indelible form, with the following information:



Warning: Manufacturing number should be included in all correspondence relating to the unit.

Ref. Produit\Item Nbr		Designation\Description	
<i>Order Nbr</i>		<i>Model</i>	
An.Year	No Serie\Serial Nbr \ No Produit		
	<i>Manufacturing Nbr</i>		
Refrigerant	kW Absorbee\Input kW	Poids\Weight	
<i>Refrigerant type</i>		<i>Weight in operation</i>	
Refrigerant kg	Tension\Voltage	Temperature Maxi C	
	<i>Line voltage</i>		
BP Mini PSM\MOP	Intensité\Current A	IP	
<i>Low pressure</i>			
HP Maxi PSM\MOP	Int.. Kit Elect.	No CE	
<i>High pressure</i>	<i>Electrical kit current</i>		
		30, av JeanFalconnier 01350 CULOZ Tel : 33(0)4 79 42 42 42	
		Made in Spain	

7. SAFETY RECOMMENDATIONS

To avoid accidents during installation, commissioning or maintenance, it is obligatory to take into account the following specifications of the units: pressurised cooling circuits, presence of refrigerant, presence of voltage and location.

For this reason maintenance and repairs must only be performed by qualified and experienced personnel.



Operating precautions indicated in the maintenance brochure, on labels or in specific instructions should be followed as well as all applicable regulations and safety standards.



Use glasses and working gloves. Be careful with the parts or sharp elements of the unit.



Caution: Before intervening in the unit, verify that the main power to the unit is cut off. An electric shock can cause personal damage.



Note: In order to recycle these units follow the stipulations of Directives (EC) No. 96/2002 and No. 108/2003 regarding electrical and electronic equipment and the management of the resulting waste.

Refrigerant leaks:

A regular control of refrigerant leaks should be carried out according to Regulation (CE) N°842/2006 about *Fluored greenhouse-effect gases*.

The refrigerant leaks could cause:

- Displacement of the available oxygen, its inhalation could cause arrhythmias (work in well ventilated areas).
- By contact they can cause ocular irritations and burns (it should be used suitable protection glasses).

These units work with refrigerant gas **R-407C**

Components of the R-410A	R-32	R-125	R-134A
Chemical formula	CH2F2	CHF2CF3	CH2FCF3
Weight ratio	23%	25%	52%
Unitary global warming potential (GWP)	675	3.500	1.430
Global warming potential (GWP)	1.774		

8. LOCATION AND ASSEMBLY

Choosing the installation site

Before moving the unit, make sure that all panels are fixed in their place. Lift and lower carefully.

For the choice of the location, whatever it is the chosen form, it should be taken into account the following points:

- It is imperative to fulfill UNE-EN 378-3 Standard about Environmental and Safety Requirements. Part 3: Installation "in situ" and people protection.
- Make sure that the structure is strong enough for supporting the weight of the unit (see weight in chart of technical characteristics).
- The area where the unit is located should be perfectly accessible for cleaning and maintenance (consult minimum space for maintenance).
- Provide for anti-vibratory supports in all the installation, in order to avoid the transmission of noises and vibrations.
- All models can be installed on the floor or over a mount or steel profile. In any case, check that the unit remains perfectly levelled.

- For outdoors installation:
 - in the installation on a mount, take special care of average height that reaches the snow in that region.
 - a protection roof should be placed on the unit (optional).
- There must be no obstacle at the outlet or return of air.
- The discharge and return grilles location should be studied carefully to avoid the air recirculation.
- These units have been designed for a silent operation. However, it should be taken into account the installation site and if the noise irradiated by the unit is higher than installation estimated value, plan:
 - an acoustic study, and appropriate acoustic treatment if it is necessary,
 - implementation precautions.

Note: consult the acoustic data provided in the technical brochure.

Weights by modules (kg)

Aquair BCP	110	140	180	230	265	315	355
Nominal flow							
Standard equipment (no optionals)	630	665	895	920	1080	1155	1175
Hot water coil	40	40	45	45	55	55	55
Bags filter module	270	270	350	350	400	400	400
2 dampers mixing box	380	380	470	470	520	520	520
Mixing box module with 3 dampers + return fan	438	444	602	609	697	700	700
High flow (optional)							
Standard equipment (no optionals)	645	675	975	995	1175	1230	1230
Hot water coil	40	40	45	45	55	55	55
Bags filter module	270	270	350	350	400	400	400
2 dampers mixing box	380	380	470	470	520	520	520
Mixing box module with 3 dampers + return fan	456	456	737	737	815	743	743

Anchorage for antivibrators

Due to the modular conception of these units, there are 6 possible configurations of frames:

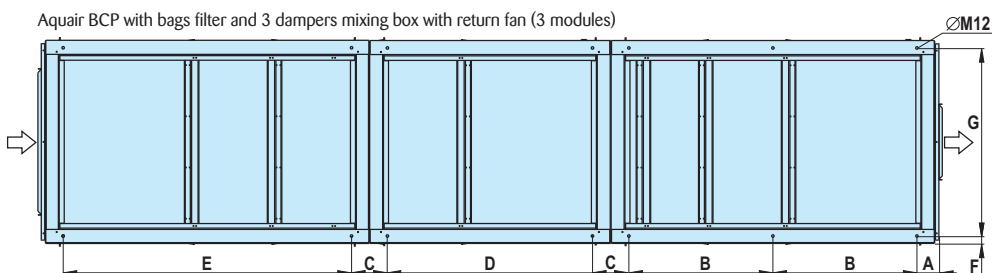
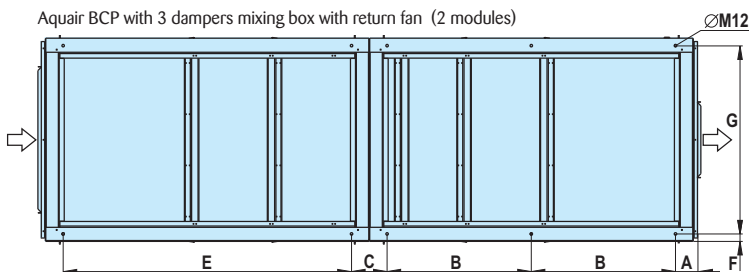
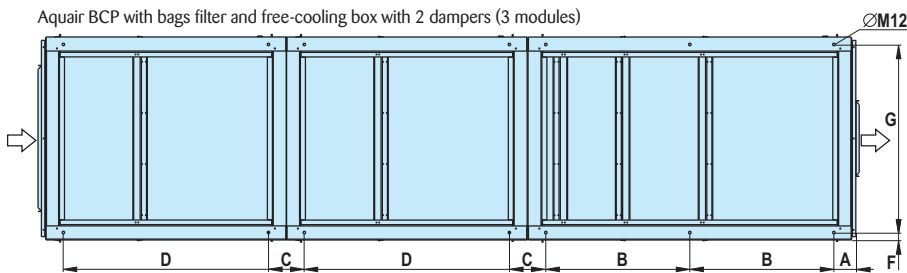
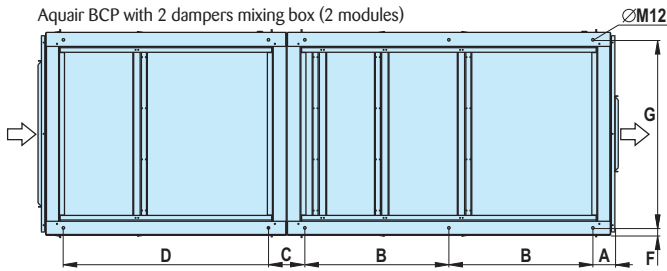
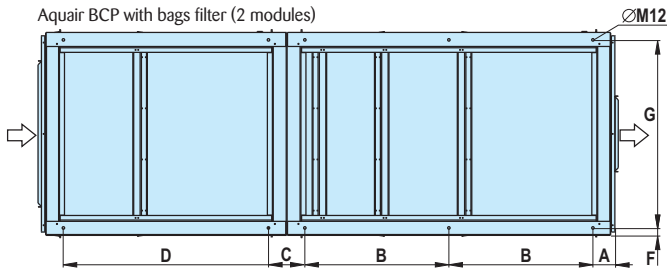
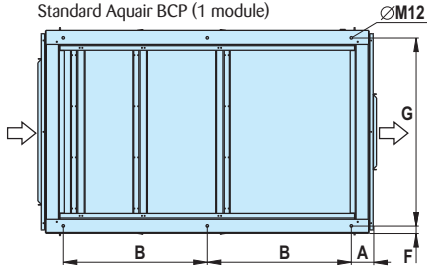

Size of the different frames (mm):

Aquair BCP	Length			Width	
	110 / 140	180 / 230	265 a 355	110 / 140	180 to 355
<i>standard</i>	2070	2282	2450	1248	1498
<i>with bags filter</i>	3621	3833	4168	1248	1498
<i>with 2 dampers mixing box</i>	3621	3833	4168	1248	1498
<i>with bags filter + 2 dampers mixing box</i>	5173	5382	5887	1248	1498
<i>with 3 dampers mixing box</i>	4078	4502	4837	1248	1498
<i>with bags filter + 3 dampers mixing box</i>	5635	6059	6395	1248	1498

Distances between drills (mm):

Aquair BCP	A	B	C	D	E	F	G
110 / 140	159	1752	259	1290	1752	55	1138
180 / 230	162	979	262	1290	1958	55	1388
265 / 315 / 355	162	1063	262	1290	2126	55	1388

Note: for models 110 and 140 standard unit only includes 4 drills.

Minimum necessary space for the commissioning and maintenance

Overview:

- Access to components through two laterals of the unit.
- Hinged doors for accessing the different sections of the unit.
- All doors and panels have built-in lockings with rubber joint ensuring watertightness.

Standard Aquair BCP

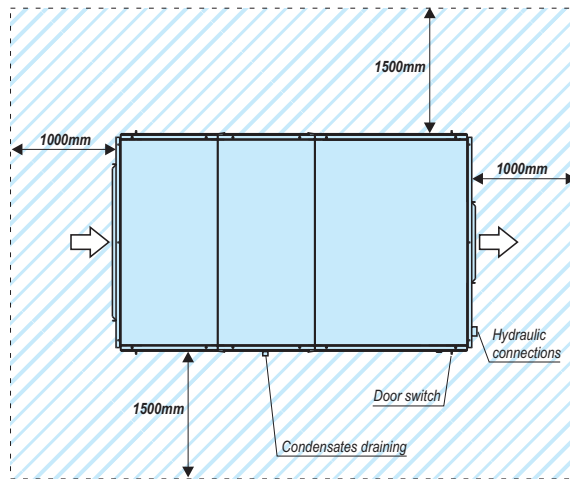

Aquair BCP with bags filter and 2 dampers mixing box

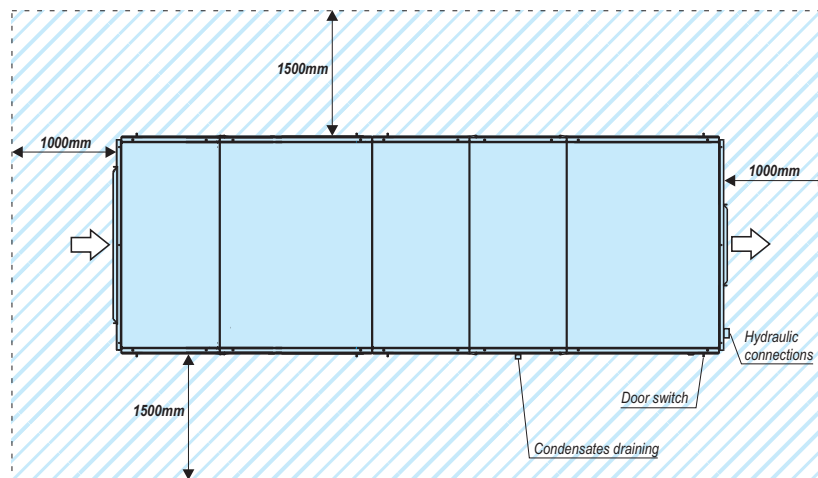

Aquair BCP with return fan and 3 dampers mixing box

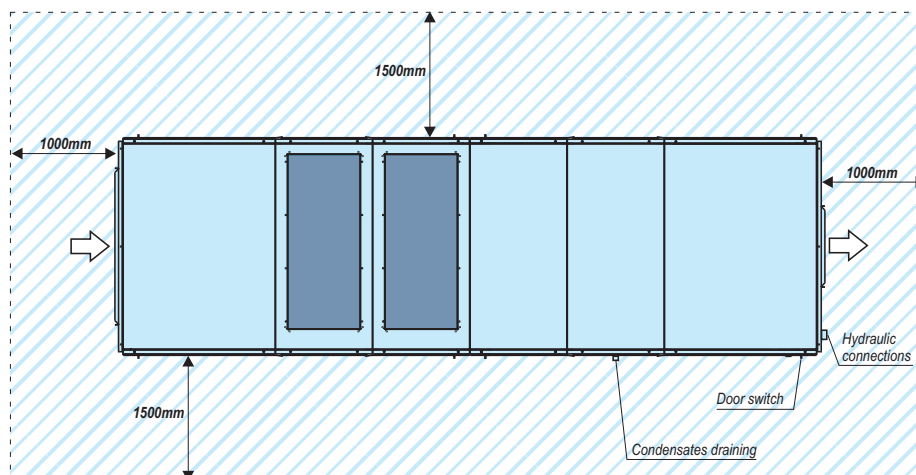

9. CHECKING BEFORE COMMISSIONING

Electrical connections

Installation norms

When carrying out the electrical connections of the unit: wires inlet, wires section and calculation of the same ones, protections, etc..., consult the information provided in this document (see technical characteristics), the electrical scheme which is sent with the unit and effective regulations which regulate the installation of air-conditioners and electrical receivers. Verify that the power supply corresponds to which it appears on the nameplate and that the voltage keeps constant.



Check that the electrical connections are correct and well tight (each unit has its own electrical diagram and legend).



In order to prevent electrical shocks, all electrical wirings should be carried out before feeding the unit. Check that the automatic switch is closed, in order to avoid personal damages. Make the ground connection before any other electrical wiring.



Warning: All electrical wirings in the installation are responsibility of the installer.



It is necessary that the wiring of the installation comply with the applicable regulation. The installer should place elements of line protection according to the effective legislation.

Electronic control

CIATpool is an electronic module designed to control and supervise swimming pool dehumidification units through a microprocessor.

This control is basically composed of a µPC MEDIUM control plate, a pGD1 graphical terminal, a TCO user terminal (optional), and sensors.

Please refer to this control brochure to obtain more detailed information about its operation.

Connection chart

Aquair BCP		110 to 355
Main power supply	400 III (±10%)	3 + N + Gnd
Remote connection of the pGD1 terminal (by default on the electric panel) ①		telephone cable 6 wires standard (RJ12 connector)
Terminal connection for TCO user in the electric panel (optional) ②		2 wires for power supply 230V + 1 shielded cable for communication type AGW20 / 22 (1 braided pair + drainwire + shielding)
Remote off/on (optional)		2 wires
Main failure signal (optional)		2 wires
pCO web card to BMS (optional)		Ethernet

① In this case, the TCO terminal can be installed in the electric panel.

② The same power supply used for powering the control board must also be used for powering the terminal.

Air ducts connections

The air outlet and return ducts must be calculated in accordance with the nominal flow and the unit's available pressure (refer to the technical characteristics table). The duct calculation and design must be made by qualified technical personnel.

It is advisable to take into consideration the following recommendations:

- Curves in the fan discharge outlet(s) must be avoided. It is recommendable to have a straight section of duct measuring approximately 1 metre. If it is not possible, they must be as smooth as possible, using indoor deflectors when the duct is of large dimensions.
- When making the ducts, direction sharp changes must be avoided since they can generate occasional pressure drops, which affect the available pressure and the flow. The location of discharge and aspiration grilles must be studied carefully to avoid the air recirculation and the transmission and generation of noises to the interior.
- Flexible connections must be made between the ducts and the unit that avoid the noise and vibration transmission.
- No matter the type of ducts used, they must be isolated and not be composed of materials that propagate fire nor expel toxic gases in the event of a fire. The internal surfaces must be smooth and should not pollute the air that circulates within them. In any case, the effective legislation about this issue must be respected.

Checks in the centrifugal fans

- Before commissioning, check the blade rotation direction and that the axis turns without strokes nor vibrations.
- Once running, check the operation conditions: pressures, flows and consumptions.
- The coupling of characteristic curves of the fan and the room is very important, so that the flows and pressures provided to the duct network are as required.

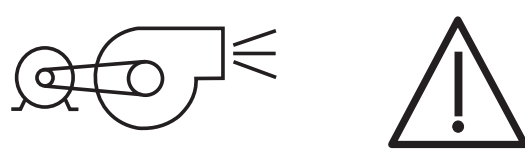

ATTENTION: AVANT OVERTURE DE CE PANNEAU COUPER L'ALIMENTATION ELECTRIQUE ET ATTENDRE 2 MN.

WARNING: BEFORE OPENING THIS PANEL SWITCH OFF THE ELECTRIC SUPPLY AND WAIT 2 MN.

ACHTUNG: VOR DER ÖFFNUNG DIESER PANEEL STROM ABSCHALTEN UND 2 MN. WARTEN.

ATENCIÓN: ANTES DE ABRIR LA PUERTA CORTAR LA ALMENTACION ELECTRICA Y ESPERAR 2 MN.

ATTENZIONE: PRIMA DI APRIRE QUESTA PARETE INTERROMPERE L'ALIMENTAZIONE ALECTRICA E ASPETTARE 2MN.

Pulley and belt calibration

If the unit has centrifugal motorfans in outlet and/or return from the indoor circuit, they are coupled through pulleys and belts. In these fans, the following must be taken into consideration:

- The pulleys must be on the same plane, so it is important to check them with the help of a ruler or a laser aligner.
- In case they are not, remove the pulley screws, remove the pulley and, after removing the hub pin, it can be slid over the axle (this action can be performed both in the motor as well as in the fan).
- After fixing the pulleys on the same plane, the belt tension is made by tightening the tensor screw.
- The belt tension must be checked after 24 hours of motor operation.

Attention: Before performing these operations, it is necessary to verify that the unit is disconnected from mains.

Motor less than 4 kW Pulleys must stay on the same plane

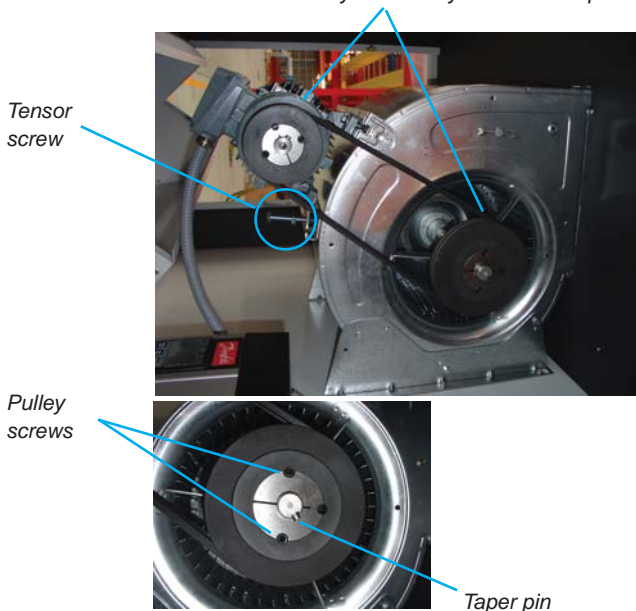

Motor from 4 kW Pulleys must stay on the same plane

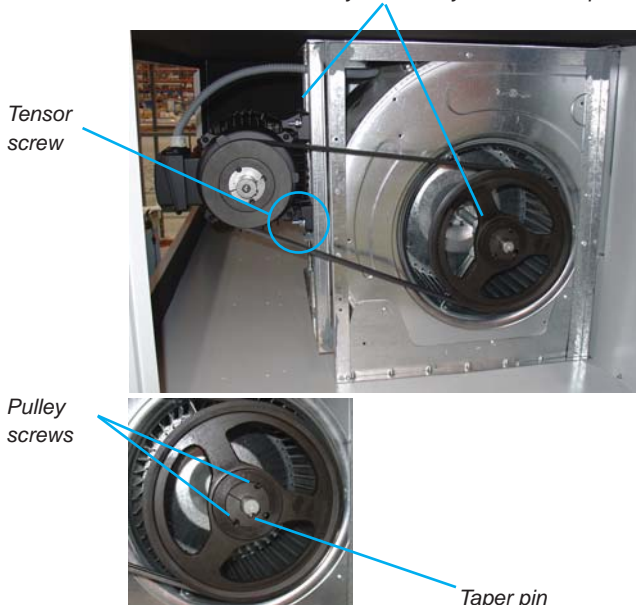

Condensates drain connection

All models built-in a stainless steel condensates drain pan, sloped to facilitate water circulation down to the drainage, avoiding sanitary problems.

Drainage pipe diameter of M3/4" in bronze, it is located in the right lateral of Aquair BCP unit (in the air flow direction).

**CONNECT SIPHON
METTRE SIPHON
PONER SIPHON**
V220014



With outdoor temperatures which are lower than 0°C the necessary precautions must be taken to prevent the water in the drain ducts from freezing.

Siphon installation norms

- Check that the condensate outlet is not clogged.
- All water drain tubes must be provided with a siphon to avoid bad smell and water spills.

Perform the assembly as per the scheme of the attached starting diagram:

Pan in overpressure:

- It is installed to avoid the access through the drain piping of bad smells.

Pan in underpressure:

Besides the previous application, water must be sucked from the pan:

- For the correct siphon design, the "A" height must be at least twice that of the underpressure (mm.a.c) where the condensate pan is placed.
- The drain piping must be slightly sloped to ease circulation towards the drain.
- The original diameter of the piping must be respected. No reduction can be made.

Note: The pipe original diameter should be respected. Reductions should not be carried out.

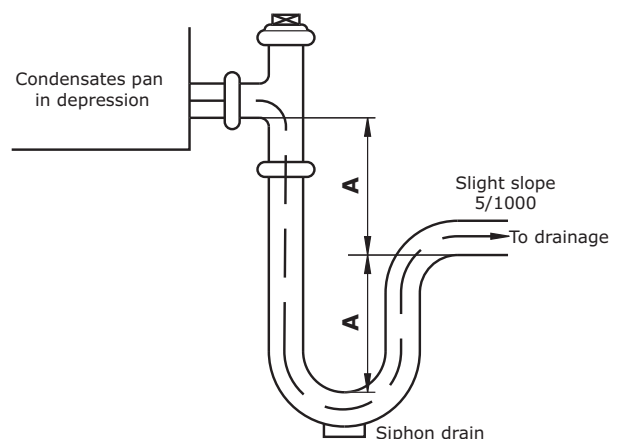

Siphon principle scheme

Check the connection air tightness.

Hydraulic connections

Installation hydraulic scheme

Follow these recommendations:

- Respect the water flow direction indicated on the unit.

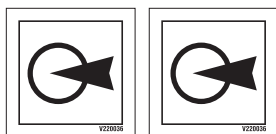

- The diameters of hydraulic connections can be consulted in the technical characteristics table (pag. 6).
- Pipes must be measured with the smaller number of curves to diminish pressure drops and must be adequately fitted to avoid force excessively the exchanger connections.
- Carry out a preliminar control to check that there are not pressure drops in the installation, before insulating pipes and load the system.
- Avoid the possible transmission of vibrations or efforts of the pipes to the water exchanger.
- Flexible couplings are recommended for connecting pipework to the unit, in order to avoid possible transmission of vibrations, breakages and efforts in the unit or in the pipes. These couplings are compulsory when the unit is mounted on a frame or on antivibratory supports.
- Provide the accessories necessary on each hydraulic circuit (expansion vessel, air vents, safety valves, shut-off valves next to components which need maintenance, etc.).
- Install, or at least anticipate the temporary introduction, thermomanometers at the inlet and outlet of the unit, to carry out the installation supervision.
- **A water mesh filter is compulsory to be placed at the inlet of pool pump (for particles of $\varnothing > 1$ mm), in order to avoid the soiling of the unit hydraulic circuit.** A good maintenance of this filter will avoid corrosion problems in the exchanger, and it will improve the heat efficiency of the unit. Not fulfill this recommendation could make useless the plates exchanger of the unit.

Important recommendations:

- If the pool water is introduced directly into the unit water condenser, the addition of chlorine should **never** be carried out before the inlet to this condenser.
- These exchangers should **never** be used in swimming pools with electrolysis efficiency treatment. In these cases it is necessary to install intermediate titanium exchanger, otherwise serious corrosion problems may occur.
- In the case of a longer standstill, leave the exchanger full of water pool without flowing or empty may cause corrosion problems. During periods of inactivity it is **mandatory** to fill up the hydraulic circuit of the exchanger completely with demineralised water. To isolate the hydraulic circuit of the rest of the installation, the installer must have shut-off valves at the input and output, and a drain for emptying.

Corrosion behaviour

The plates exchangers of Aquair BCP units are made up of SMO-254 stainless steel, and the material used for the plates welding is pure copper.

The attached table indicates the behaviour to corrosion for stainless steel SMO-254 with respect to different compositions of water. Values outside these ranges may suppose corrosion problems.

Water content	Concentration (mg/l or ppm)	Time limits (analyze before)	SMO-254
Alkalinity (HCO ₃ ⁻)	< 70	Within 24h	+
	70 - 300		+
	> 300		+
Sulphate ① (SO ₄ ²⁻)	< 70	No limit	+
	70 - 300		+
	> 300		+
HCO ₃ ⁻ / SO ₄ ²⁻	> 1.0	No limit	+
	< 1.0		+
Electrical conductivity	< 10 μS/cm	No limit	+
	10-500 μS/cm		+
	> 500 μS/cm		+
pH ②	< 6.0	Within 24h	0
	6.0 - 7.5		+
	7.5 - 9.0		+
	> 9.0		+
Ammonium (NH ₄ ⁺)	< 2	Within 24h	+
	2 - 20		+
	> 20		+
Chlorides (Cl ⁻)	< 100	No limit	+
	100 - 200		+
	200 - 300		+
	> 300		+
Free chlorine (Cl ₂)	< 1	Within 5 horas	+
	1 - 5		0
	> 5		-
Hydrogen sulfide (H ₂ S)	< 0.05	No limit	+
	> 0.05		+
Free (aggressive) carbon dioxide (CO ₂)	< 5	No limit	+
	5 - 20		+
	> 20		+
Total hardness (°dH)	4.0 - 8.5	No limit	+
Nitrate ① (NO ₃ ⁻)	< 100	No limit	+
	> 100		+
Iron ③ (Fe)	< 0.2	No limit	+
	> 0.2		+
Aluminium (Al)	< 0.2	No limit	+
	> 0.2		+
Manganese ③ (Mn)	< 0.1	No limit	+
	> 0.1		+

① Sulfates and nitrates works as inhibitors for piping corrosion caused by chlorides in pH neutral environments.

② In general, low pH (below 6) increases corrosion risk and high pH (above 7.5) decreases the corrosion risk.

③ Fe³⁺ and Mn⁴⁺ are strong oxidants and may increase the risk for localised corrosion on stainless steels.

SiO₂ above 150 ppm increase the risk of scaling.

Legend:

+ Good resistance under normal conditions.

0 Corrosion problems may occur specially when more factors are value 0.

- Use is not recommended.

Pressure drops in the condenser

The hydraulic circuit design must respect the operating conditions (flows - pressure drops).

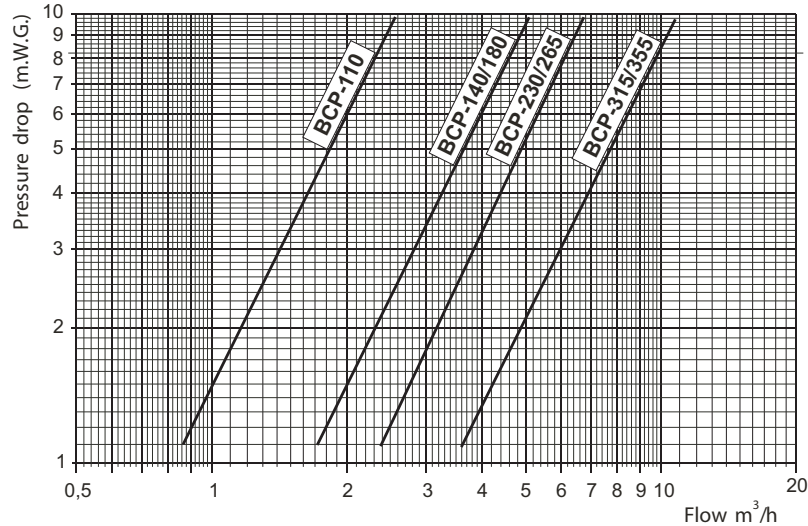

10. OPTIONALS

Hot water coil

- **Characteristics:**
 - Hot water coils, with 3 ways valve managed by the electronic control of the unit.
 - Assembly inside the unit.
 - Polyurethane or copper-copper coating.
 - The main technical characteristics of coils and the diameters of hydraulic connections can be consulted on page 6.
- **Coil filling:**
 - Coil filling should be carried out with the air vent open, until the water leaks, moment of closing it.
 - Cut the water supply and thus the generated bubbles rise to the highest point of the coil, coincident with the air vent, and eliminate opening it.
 - Introduce water in the circuit again and repeat the previous steps.
 - Drive the water pump (provided by the installer) and repeat the previous steps until air noises are not listened in the pipe, at that moment the filling of the installation will have been completed correctly.
- **Operation:**
 - It's used as support in heating mode to raise the ambient temperature.

Note: Please refer to the CIATpool control brochure to obtain more detailed information about its operation.

Note: Water flow direction must be correct for that it is convenient to follow these indications:



Electrical heater

- **Characteristics:**
 - Assembly inside the unit.
 - 1 or 2 stages electrical heaters, with built-in control.
- **Operation:**
 - It's used as support in heating mode to raise the ambient temperature.

Note: Please refer to the CIATpool control brochure to obtain more detailed information about its operation.

Mixing boxes for enthalpic free-cooling

- **Characteristics:**
 - Mixing box for free-cooling with 3 motorized dampers. Available in two configurations:
 - 2 dampers boxes, with upper external intake.
 - 3 dampers boxes, upper intakes and centrifugal return fan.
- **Operation:**
 - This optional will be enabled when there is not dehumidification demand, acting always as first stage, previous to air circuits or water circuits.

Manual external air intake damper

This damper is dedicated to the continuous air renovation, with no need of free-cooling. The user will manually fit the external air flow that he considers necessary for the renovation.

It is located in the right lateral access door to the compressors (in the sense of air flow), previous to the section of filters. If the unit incorporates the module of bags filters, this damper is located in this module, previous to bags filter.

(See section of components distribution, pag. 23).

Remote condensation

Aquair BCP AERO

This optional replaces the recovery water circuit which condensates on the plate exchanger by a split air circuit in which the condensation is carried out outside by a remote aerocondenser.

This is a solution for covered pools applications that do not need heat recovery on the pool water vessel.

The aerocondenser external unit, basically composed by fan(s) and coil, can be selected with centrifugal fan from ASN and ASM series, or with axial fan from ASJ and ASW series.

IMPORTANT: These aerocondenser units have to include the optional of condensing pressure control.

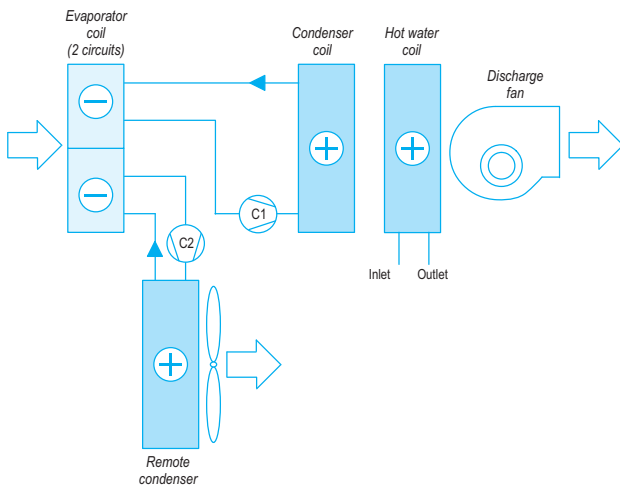

Aquair BCP DUAL

This optional enables to select the condensation process on the internal air circuit or by remote external condenser, depending on the comfort needs.

In models with two air circuits, the circuit with greater capacity can be switched with the aerocondenser. The condenser exchange is done by the electronic control based on the ambient temperature.

The aerocondenser external unit, basically composed by fan(s) and coil, can be selected with centrifugal fan from ASM series, or with axial fan from ASW series.

IMPORTANT: These aerocondenser units have to include the condensing pressure control optional.

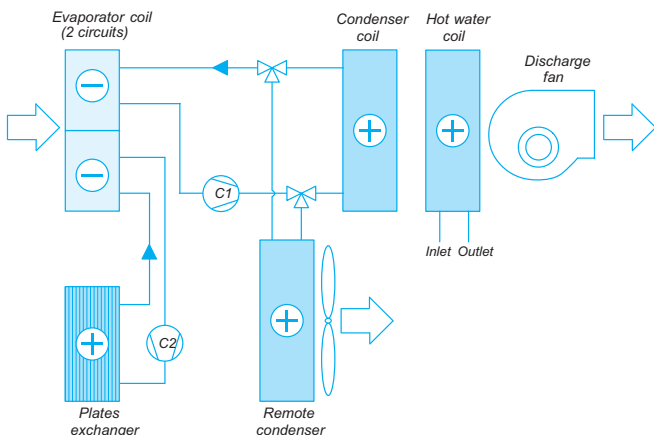

Aerocondenser transport

The unit should be handled with care in order to avoid damages in its transport. For this reason it is advisable:

- Use appropriate transports for bigger units until the installation site.
- For transport in container, it should be used those containers with an easy loading/unloading to the installation site.
- Do not remove the unit from its pallet and packing until it has been transported to its final location.
- Transport the units by a lifting truck (all series).

In ASJ and ASW series, units can also be transported by lifting slings only applied to the lifting holes of the unit. The slings should be separated by a crossbar to avoid damaging the casing.

Unit identification

All units bear, legibly and indelibly, a data plate located in a prime space, as appears in the attached image. Check that this plate matches the correct model.



Note: The serial number must be used in all communications regarding the unit.

Ref. Product/Item Nbr	Designation/Description	
Order Nbr	Model	
An. Year	No Serie/Serial Nbr	No Product
	Manufacturing Nbr	
Refrigerant	kW Absorbee/Input kW	Poids/Weight
Refrigerant type		Weight in operation
Refrigerant kg	Tension/Voltage	Temperature Maxi C
	Line voltage	
BP Mini PSM/MOP	Intensité/Current A	IP
Low pressure		
HP Maxi PSM/MOP	Int. Kit Elect.	No CE
High pressure	Electrical kit current	
30, av JeanFalconnier 01350 CULOZ Tel : 33(0)4 79 42 42 42		Made in Spain

Location and assembly of aerocondenser unit

Before moving the unit, make sure that all panels are fixed in their place. Lift and lower carefully.

In the choice of the location, whatever it is the chosen form, it should be taken in

to account the following warnings:

- It is imperative to fulfill UNE-EN 378-3 Standard about Environmental and Safety Requirements. Part 3: Installation "in situ" and people protection.
- Make sure that the structure is strong enough for supporting the weight of the unit (see weight in chart of technical characteristics).
- The area where the unit is located should be perfectly accessible for cleaning and maintenance (consult minimum space for maintenance).
- Provide for anti-vibratory supports in all the installation, in order to avoid the transmission of noises and vibrations.

- Specific installation standards should be followed for each unit:

Aerocondenser units designed to be installed indoor (ASM and ASN)

All models can be installed on the floor or over a mount or steel profile. Provide for anti-vibratory supports, to avoid vibration transmission.

- Also it is possible to be fastened to the ceiling with a spiral rod:
 - Insert in the forged 4 M8 threaded rods.
 - Introduce the rods by the drills that the unit has in its base.
 - Put the buffers, introduce a washer and thread the nuts until the unit is well fastened.
 - If there is sufficient space between the forged and the unit, some rubber plate or neoprene can be installed.

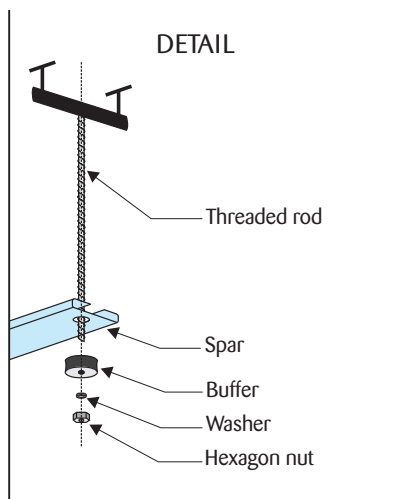

IMPORTANT: In any case, check that the unit remains perfectly levelled.

For installations with non-ducted return air, it is necessary to provide a plenum composed by the roof, forged and walls, grilles of appropriate sizes for the return air suction.

Aerocondenser units designed to be installed outdoors (ASW and ASJ)

- The unit will be located outside the room, in a terrace or garden.
 - If it is foreseen that the unit works more in heating than in cooling mode, best facing the sun.
 - If not much work foreseen in heating mode, best facing north.
- All models can be installed on the floor or over a mount or steel profile.
 - Provide for anti-vibratory supports, to avoid vibration transmission.
- Another aspect to be considered in the location of the unit will be the average snow height for the region of installation.
- There must be no obstacle to the free flow of air at the outlet or return. Nothing should block the air intake on the coil.
 - Do not place the side of the coil in the predominant wind direction.

Minimum necessary space for commissioning & maintenance

ASJ Series

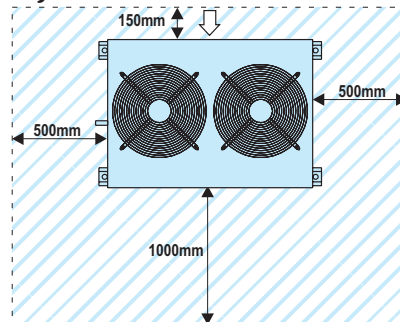

ASW Series

Models - 100 - 120 - 185

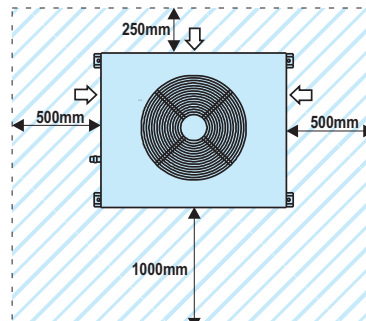

Models - 315

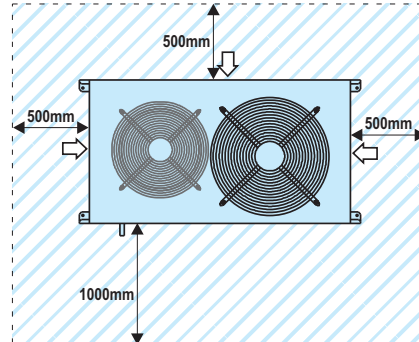

ASM Series

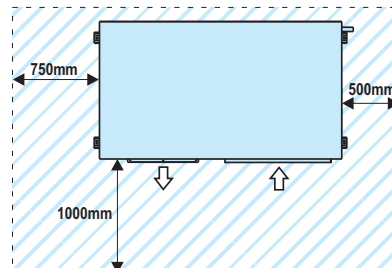

ASN Series

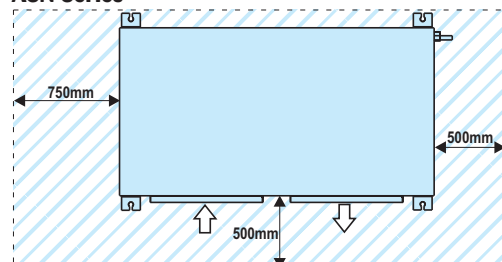

Anchorage for antivibrators

ASJ Series

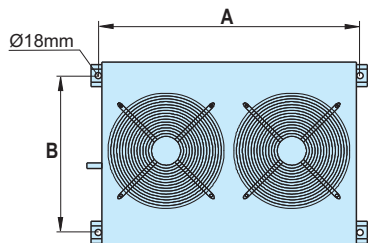

Serie ASJ	A	B
45	1056	634
55	1056	634
70	1056	634

ASW Series

Models 100 - 120 - 185

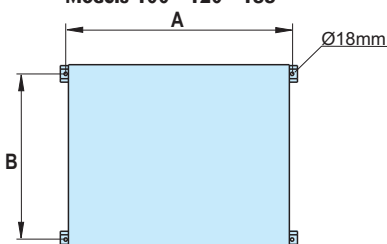

Model 315

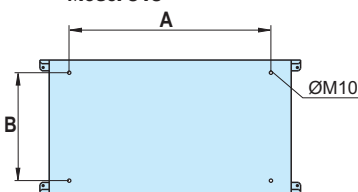

Serie ASW	A	B
100	1230	900
120	1230	900
185	1230	900
315	1561	920

ASM Series

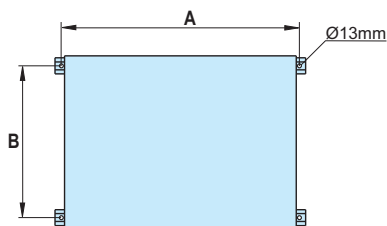

Serie ASM	A	B
80	1645	698
120	2018	944
155	2018	944

ASN Series

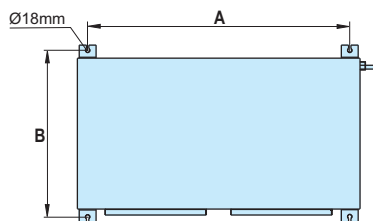

Serie ASN	A	B
45	1342	760
65	1342	760

Checking before commissioning of the aerocondenser unit

Air ducts connections (ASN and ASM):

Follow the guidelines and recommendations given to Aquair BCP units (page 11).

Checks in centrifugal fans (ASN and ASM):

Follow the guidelines and recommendations given to Aquair BCP units (page 11).

Cooling connections

Once installed Aquair BCP unit and aerocondenser unit, cooling connections must be carried out between them.

For ASM and ASW aerocondenser units, it is recommended to put a siphon in the gas line every 3 m of drop to facilitate oil return to the compressor.



For length calculation, it should be considered charge drops in accessories.

Pressure drops expressed as equivalent lengths (m):

Pipe diameter (inches)	5/8"	7/8"	1 1/8"	1 3/8"	1 5/8"	2 1/8"
Eq. length of a 45° bend (m)	0,30	0,39	0,48	0,60	0,75	0,90
Eq. length of a 90° bend (m)	0,54	0,72	0,90	1,10	1,30	1,65
Eq. length of a 180° bend (m)	0,80	1,00	1,30	1,80	2,00	2,60

Respect piping work installation standards and study carefully the pipeworks layout, looking for the shortest distance and the smaller possible number of curves. Avoiding also throttlings, using great curvature radius (curvature radio should be $\geq 3,5 \times \varnothing$).

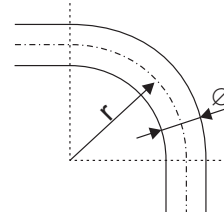

Recommendations:

- For refrigerant lines, use only seamless tube of refrigeration type. Under no circumstances should copper tube of sanitary application be used.
- Smooth and clean pipe ends to remove all burrs from the cut or any other impurity dropped into the tubing or in the external surface. The watertightness of the joint will depend on the pipes cleaning. We will also avoid the pipes fouling which will obstruct some points of the cooling circuit.
- Apply insulant to the pipe, covering it and fixing it with an adhesive band. The material used must guarantee the watertightness to pressure and working temperature.
- Pull out the taps which protect the cooling connections at the moment of pipes connection.
- Align accurately the two parts of the connection (unit and piping). Error does not occur when the two pipes have different diameters.
- Make a pressure and leak test of the piping to check the cooling installation.
- Evacuation of the installation to eliminate the humidity inside the circuit.
- Proceed to the gas charge of the unit according to the data on the technical specifications table. If the equivalent length of the cooling lines is upper than 7 m, an additional charge must be made by each meter according to the following table.

R 407C
V 220508

Nominal diameter	1/4"	3/8"	1/2"	5/8"	3/4"	7/8"	1"	1 1/8"	1 3/8"	1 5/8"
Internal section (cm ²)	0,15	0,44	0,9	1,51	2,28	3,12	4,29	5,35	7,85	10,1
Liquid line load (g/m)	18	53	107	180	272	376	512	638	937	1325
Gas line load (g/m)	--	0,19	0,38	0,64	0,97	1,33	1,83	2,30	3,30	4,00

Note: Check the liquid subcooling during commissioning to make sure that the charge is correct.

Aquair BCP AERO		110	140	180	230	265	315	355
Axial aerocondenser model		ASJ-45	ASJ-55	ASJ-70	ASJ-70	ASW-100	ASW-120	ASW-120
From 6 m	Liquid line	3/8"	1/2"	5/8"	5/8"	5/8"	5/8"	5/8"
	Gas line	7/8"	7/8"	1 1/8"	1 1/8"	1 1/8"	1 1/8"	1 1/8"
From 10 m	Liquid line	3/8"	1/2"	5/8"	5/8"	5/8"	5/8"	5/8"
	Gas line	7/8"	7/8"	1 1/8"	1 1/8"	1 1/8"	1 1/8"	1 1/8"
15 m	Liquid line	1/2"	1/2"	5/8"	5/8"	5/8"	5/8"	5/8"
	Gas line	7/8"	1 1/8"	1 1/8"	1 1/8"	1 3/8"	1 5/8"	1 5/8"

Aquair BCP AERO		110	140	180	230	265	315	355
Centrifugal aerocondenser model		ASN-45	ASN-45	ASN-65	ASN-65	ASM-80	ASM-120	ASM-120
From 6 m	Liquid line	3/8"	3/8"	5/8"	5/8"	5/8"	5/8"	5/8"
	Gas line	7/8"	7/8"	1 1/8"	1 1/8"	1 1/8"	1 1/8"	1 1/8"
From 10 m	Liquid line	3/8"	3/8"	5/8"	5/8"	5/8"	5/8"	5/8"
	Gas line	7/8"	7/8"	1 1/8"	1 1/8"	1 1/8"	1 1/8"	1 1/8"
15 m	Liquid line	1/2"	1/2"	5/8"	5/8"	5/8"	5/8"	5/8"
	Gas line	7/8"	7/8"	1 1/8"	1 1/8"	1 1/8"	1 5/8"	1 5/8"

Aquair BCP DUAL		110	140	180	230	265	315	355
Axial aerocondenser model		ASW-100	ASW-100	ASW-120	ASW-185	ASW-315	ASW-120	ASW-120
From 6 m	Liquid line	5/8"	5/8"	5/8"	5/8"	5/8"	5/8"	5/8"
	Gas line	1 1/8"	1 1/8"	1 1/8"	1 3/8"	1 3/8"	1 1/8"	1 1/8"
From 10 m	Liquid line	5/8"	5/8"	5/8"	5/8"	5/8"	5/8"	5/8"
	Gas line	1 1/8"	1 1/8"	1 1/8"	1 3/8"	1 3/8"	1 1/8"	1 1/8"
From 15 m	Liquid line	5/8"	5/8"	5/8"	5/8"	5/8"	5/8"	5/8"
	Gas line	1 3/8"	1 3/8"	1 5/8"	1 5/8"	1 5/8"	1 5/8"	1 5/8"

Aquair BCP DUAL		110	140	180	230	265	315	355
Centrifugal aerocondenser model		ASM-80	ASM-80	ASM-120	ASM-155	--	ASM-120	ASM-120
From 6 m	Liquid line	5/8"	5/8"	5/8"	5/8"	--	5/8"	5/8"
	Gas line	1 1/8"	1 1/8"	1 1/8"	1 3/8"	--	1 1/8"	1 1/8"
From 10 m	Liquid line	5/8"	5/8"	5/8"	5/8"	--	5/8"	5/8"
	Gas line	1 1/8"	1 1/8"	1 1/8"	1 3/8"	--	1 1/8"	1 1/8"
15 m	Liquid line	5/8"	5/8"	5/8"	5/8"	--	5/8"	5/8"
	Gas line	1 1/8"	1 1/8"	1 5/8"	1 5/8"	--	1 5/8"	1 5/8"

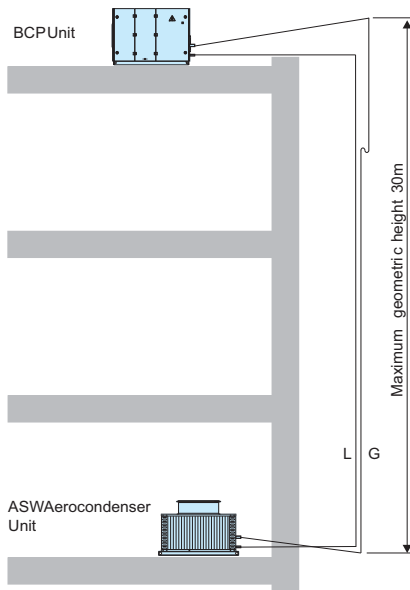

Maximum length of cooling line:
ASW = 40m

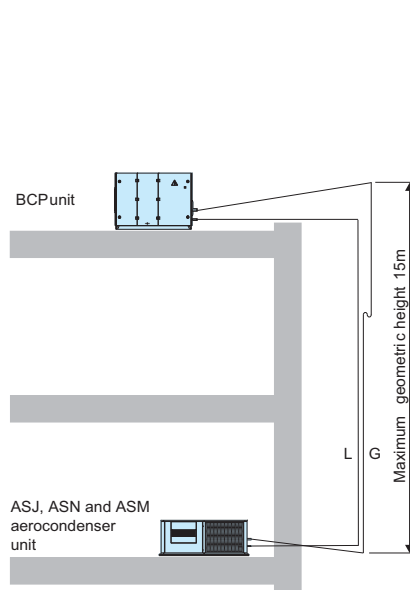

Maximum length of cooling line:
ASJ, ASN and ASM = 15m

L liquid line
G gas line
Siphon in gas line every 3m of fall

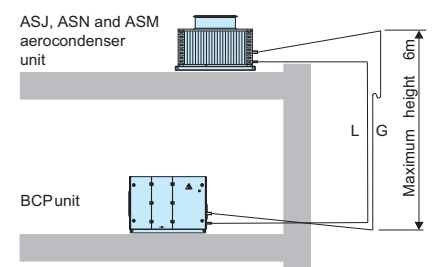

Maximum length of cooling line:
ASW, ASJ, ASN and ASM = 7m



Pool air handling units

Technical characteristics

Aquair BCP AERO		110	140	180	230	265	315	355
Axial aerocondenser model		ASJ-45	ASJ-55	ASJ-70	ASJ-70	ASW-100	ASW-120	ASW-120
Total dehumidification capacity (kg/h) ①		20,8	25,6	33,9	42,2	51,1	60,3	70,4
Remote condensation circuit dissipated capacity (kW)		10	16,9	20,7	24,9	28,2	43,1	43,1
Fan	Nominal air flow (m³/h)	4.500	6.500	6.500	6.500	10.000	14.500	14.500
	Available static pressure (mm.w.c)	--						
	Fan type / Number	2 / 360	2 / 450	2 / 450	2 / 450	1 / 630	1 / 800	1 / 800
	Power(kW)	0,12	0,15	0,15	0,15	0,7	1,05	1,05
	Speed (r.p.m.)	1.300	870	870	870	900	680	680
Maximum absorbed current	230 V / I ph / 50 Hz (A)	1,1	1,3	1,3	1,3	--	--	--
	400 V / III ph / 50 Hz (A)	--	--	--	--	1,3	2,4	2,4
Refrigerant	Type	R-407c						
	Total load (kg)	10,3	15,2	17,2	16,9	19,4	18,3	21,8
Cooling connections	Liquid line	3/8"	1/2"	1/2"	1/2"	5/8"	5/8"	5/8"
	Gas line	5/8"	7/8"	7/8"	7/8"	1 1/8"	1 1/8"	1 1/8"
Dimensions	Length (mm)	1.114	1.114	1.114	1.114	1.288	1.288	1.288
	Width (mm)	744	744	744	744	1.000	1.000	1.000
	Height (mm)	980	980	980	980	1.223	1.223	1.223
Weight (kg)		96	104	172	172	164	159	159
Sound pressure level dB(A) ②		37	45	45	45	52	50,7	50,7

Aquair BCP AERO		110	140	180	230	265	315	355
Centrifugal aerocondenser model		ASN-45	ASN-45	ASN-65	ASN-65	ASM-80	ASM-120	ASM-120
Total dehumidification capacity (kg/h) ①		21,0	26,3	34,8	42,5	52,4	62,1	71,3
Remote condensation circuit dissipated capacity (kW)		10	16,9	20,7	24,9	28,2	43,1	43,1
Fan	Nominal air flow (m³/h)	3.500	3.500	4.500	4.500	6.500	10.000	10.000
	Available static pressure (mm.w.c)	4	4	5	5	7	13	13
	Fan type / Number	1	1	1	1	1	1	1
	Power(kW)	0,51	0,51	0,6	0,6	1,1	1,5	1,5
	Speed (r.p.m.)	890	890	1.100	1.100	630	543	543
Maximum absorbed current	230 V / I ph / 50 Hz (A)	3,8	3,8	8,2	8,2	--	--	--
	400 V / III ph / 50 Hz (A)	--	--	--	--	2,7	3,6	3,6
Cooling connections	Liquid line	3/8"	3/8"	1/2"	1/2"	5/8"	5/8"	5/8"
	Gas line	5/8"	5/8"	7/8"	7/8"	1 1/8"	1 1/8"	1 1/8"
Refrigerant	Type	R-407c						
	Total load (kg)	8,9	13,2	16,2	16,0	19,7	16,8	20,7
Dimensions	Length (mm)	1.428	1.428	1.428	1.428	1.680	2.088	2.088
	Width (mm)	804	804	804	804	937	1.220	1.220
	Height (mm)	460	460	460	460	670	810	810
Weight (kg)		108	108	120	120	214	324	324
Sound pressure level dB(A) ②		44,4	44,4	50	50	56,7	60,9	60,9

① Cooling dehumidification capacity of Aquair BCP AERO unit with remote aerocondenser for outdoor temperature conditions of 35°C.

② The sound pressure level depends on the installation conditions and, therefore, it is only a reference. Measure conditions: in free field, measured at 5 meters of length, directivity 2 and at 1,5 meters from floor.

Technical characteristics

Aquair BCP DUAL		110	140	180	230	265	315	355
Axial aerocondenser model		ASW-100	ASW-100	ASW-120	ASW-185	ASW-315	ASW-120	ASW-120
Total dehumidification capacity (kg/h) ①		21,1	26,0	32,6	40,1	47,2	62,7	72,6
Remote condensation circuit dissipated capacity (kW)		27,5	30,1	42,0	55,0	63,4	42,6	42,6
Fan	Nominal air flow (m³/h)	10.000	10.000	14.500	22.000	28.000	14.500	14.500
	Available static pressure (mm.w.c)	--						
	Fan type / Number	1 x 630	1 x 630	1 x 800	1 x 800	800 + 630	1 x 800	1 x 800
	Power(kW)	0,7	0,7	1,05	2,0	2,0 / 1,25 + 0,7 / 0,5	1,05	1,05
	Speed (r.p.m.)	900	900	680	880	880 / 660 900 / 690	680	680
Maximum absorbed current	400 V / III ph / 50 Hz (A)	1,3	1,3	2,4	4,0	4,0 + 1,3	2,4	2,4
Refrigerant	Type	R-407c						
	Total load (kg)	7,4	8,6	14,7	15,5	17,8	16,9	18,2
Cooling connections	Liquid line	5/8"	5/8"	5/8"	5/8"	5/8"	5/8"	5/8"
	Gas line	1 1/8"	1 1/8"	1 1/8"	1 3/8"	1 3/8"	1 1/8"	1 1/8"
Dimensions	Length (mm)	1.288	1.288	1.288	1.288	1.991	1.288	1.288
	Width (mm)	1.000	1.000	1.000	1.000	1.018	1.000	1.000
	Height (mm)	1.223	1.223	1.223	1.523	1.380	1.223	1.223
Weight	(kg)	164	164	159	233	442	159	159
Sound pressure level dB(A) ②		52	52	50,7	58,7	61,9	50,7	50,7

Aquair BCP DUAL		110	140	180	230	265	315	355
Centrifugal aerocondenser model		ASM-80	ASM-80	ASM-120	ASM-155	--	ASM-120	ASM-120
Total dehumidification capacity (kg/h) ①		21,0	25,7	30,3	38,8	--	60,6	70,8
Remote condensation circuit dissipated capacity (kW)		27,5	30,1	42,0	55,0	--	42,6	42,6
Fan	Nominal air flow (m³/h)	6.500	6.500	10.000	12.200	--	10.000	10.000
	Available static pressure (mm.w.c)	7	7	13	14	--	13	13
	Fan type / Number	1	1	1	1	--	1	1
	Power(kW)	1,1	1,1	1,5	3	--	1,5	1,5
	Speed (r.p.m.)	630	630	543	626	--	543	543
Maximum absorbed current	400 V / III ph / 50 Hz (A)	2,7	2,7	3,6	6,9	--	3,6	3,6
Cooling connections	Liquid line	5/8"	5/8"	5/8"	5/8"	--	5/8"	5/8"
	Gas line	1 1/8"	1 1/8"	1 1/8"	1 3/8"	--	1 1/8"	1 1/8"
Refrigerant	Type	R-407c						
	Total load (kg)	7,4	8,6	14,7	15,5	--	16,9	18,2
Dimensions	Length (mm)	1.680	1.680	2.088	2088	--	2.088	2.088
	Width (mm)	937	937	1.220	1220	--	1.220	1.220
	Height (mm)	670	670	810	810	--	810	810
Weight	(kg)	214	214	324	350	--	324	324
Sound pressure level dB(A) ②		56,7	56,7	60,9	65,6	--	60,9	60,9

① Cooling dehumidification capacity of Aquair BCP DUAL unit with remote aerocondenser for outdoor temperature conditions of 35°C.

② The sound pressure level depends on the installation conditions and, therefore, it is only a reference. Measure conditions: in free field, measured at 5 meters of length, directivity 2 and at 1,5 meters from floor.

11. SAFETY DEVICES

High pressure pressostat

Connected in the compressor discharge, this will stop the compressor when the pressure on this point reaches the set point value. This pressostat disconnects at 29 bar. Automatic reset.



In Aquair BCP unit will be kept operating: the internal fan, the external air control and in the compressor of water condenser circuit, the circulation pump.

Low pressure pressostat

Connected in the compressor intake, this will stop the compressor when the pressure on this point decreases under the measured value (caused by cloggings in the circuit, excessive soiling in the filters, fan stop or frost in the evaporator). It disconnects at 0,5 bar. Automatic reset.



In Aquair BCP unit will be kept operating: the internal fan, the external air control and in the compressor of water condenser circuit, the circulation pump.

Compressors and fans safeties

Both fans and compressor have a built-in motor thermal protection device. This device protects the motor against overheating due to an overcurrent.

If a failure is detected in the discharge fan, the unit will stop automatically. If the failure is detected in the compressor, the compressor in question will stop.

Compressor anti-short-cycle timer

The compressor does not start-up until the anti-short-cycle time delay has lapsed from its last stop.

Magnetothermals for line protection

They are located at the beginning of the power lines for the compressors and motor fan(s) to protect them.

Control circuit automatic switch

Magnetothermal switch which protects the circuit so much against continuous overcurrents as high short currents (shortcircuits).

Main door switch

By using a mechanical device, it impedes access to the electric panel when the unit is with voltage.

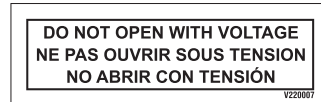

Anti-fire safety

With the return air probe, the electronic control can activate an anti-fire safety device that detains the unit when the return air surpasses a temperature of 60°C (by default). It cannot return to operation until the temperature has dropped to below 40°C.

Clogged filter detector (optional)

Differential pressostat for indication, through an automatic reset alarm, of a level of dirtiness of the filters greater than the established level. Automatic reset.

Return air temperature probe

A fault detected in this probe causes the stop of the unit.

Exchanger inlet/outlet water temperature probe

A fault detected in any of these probes in the plate exchanger causes the stop of the compressor of the water condenser circuit.

HWC water temperature

If an antifreeze alarm is generated in the hot water coil:

- In HEATING mode: this closes outdoor air damper and opens HWC valve.
- In COOLING mode: this stops compressors and closes outdoor damper.

12. COMMISSIONING



Warning: the commissioning of the installation should be carried out by CIAT personnel. Please, communicate with personnel of technical assistance when the previous works have been concluded.

Operating temperature of the pool

After seasonal shutdowns of the unit follow these steps for the run up:

- Check that all wirings, hydraulic connections and all pipings have been properly connected and in good condition.

WICHTIG: WIEDERBEHEIZUNG DER OLWANNE

BEIDER ERSTEN INBETRIEBSETRUNZ ORDER NACH EINER LANGEN STROMUNTER-BRECHUNG BRINGEN SIE DIE MASCHINE UNTER SPANNUNG 24 STRUNDERLANG BEVOR SIE DEN(DIE) KOMPRESSOR(EN) EINSCHALTEN KOENNEN.

IMPORTANT: CRANKCASE HEATING

FOR THE FIRSTSTART OR AFTER ALONG TIME OUT OF VOLTAGE PUT THE MACHINE ON LIVE 24 HOURS BEFORE TO ALLOW THE COMPRESSOR(S) STARTING

IMPORTANT: SURCHAUFFE CARTER D'HUILE

AU PREMIER DÉMARRAGE OU APRÈS UNE ABSCENCE DE COURANT PROLONGÉE, METTRE LA MACHINE SOUS TENSION 24 HEURES AVANT D'AUTORISER LE DÉMARRAGE DU(DES) COMPRESSEUR(S).

IMPORTANTE: RISCALDARE IL CARTER DELL'OLIO

AL PRIMO AVVIAMENTO U DOPO UNA INTERRUZIONE PROLUNGATA DELLA ALIMENTAZIONE ELETTRICA, LASCIARE LA MACCINA SOTTO TENSIONE PER 24 ORE PRIMA DI AUTORIZZARE L'AVVIAMENTO DEL(DEI) COMPRESSORE(I).

IMPORTANTE: RECALENTAMIENTO DE ACEITE DEL CÁRTER

ANTES DEL PRIMER ARRANQUE O DESPUÉS DE UNA AUSENCIA DE CORRIENTE POR UN LARGO PERIODO DE TIEMPO, CONVIENE QUE LA UNIDAD ESTÉ CONECTADA UN MÍNIMO DE 24 HORAS.

V220084

- Once the above verifications have been carried out, the control circuit is supplied with voltage by the automatic control switch. It is necessary to leave the compressor crankcase heater with voltage for 24 hours before starting the compressor.
- When starting-up the compressor, if the refrigerant load has not been completed and lower than the required, the intake pressure will be quite lower than the normal one. The low pressure pressostat connected at the compressor intake, will stop its operation when the pressure on that point decreases under the setting value (disconnects at 0,5 bar and automatic reset).
- Ensure that there is no refrigerant leak or air in the circuit.
- Measure temperatures of liquid line and intake line, as well as discharge and intake pressure temperatures. Check that undercooling and overheating values are within the allowable limits.
- Check that the unit operates correctly and verify that the current absorbed by each motor is normal.
- Check all safety devices operate correctly. If a safety is active, is necessary to find the failure and then reset the safety.
- Check the selected values for humidity and temperature set points in the control panel. Please refer to the CIATpool control brochure to obtain more detailed information.
- The differential between air and water temperatures should be checked. The air temperature should be about 2 or 3°C higher than water temperature avoiding condensations on walls and windows inside the room.
- Check by-pass gate position of manual setting, adjusting the opening percentage to the installation needs.
- Doors and windows must be closed to facilitate the increase of air and water temperature. Free-cooling gates (optional) must be placed on the position of minimum opening.
- Check motorized damper of free-cooling (optional).

13. COMPONENTS DISTRIBUTION

Standard Aquair BCP

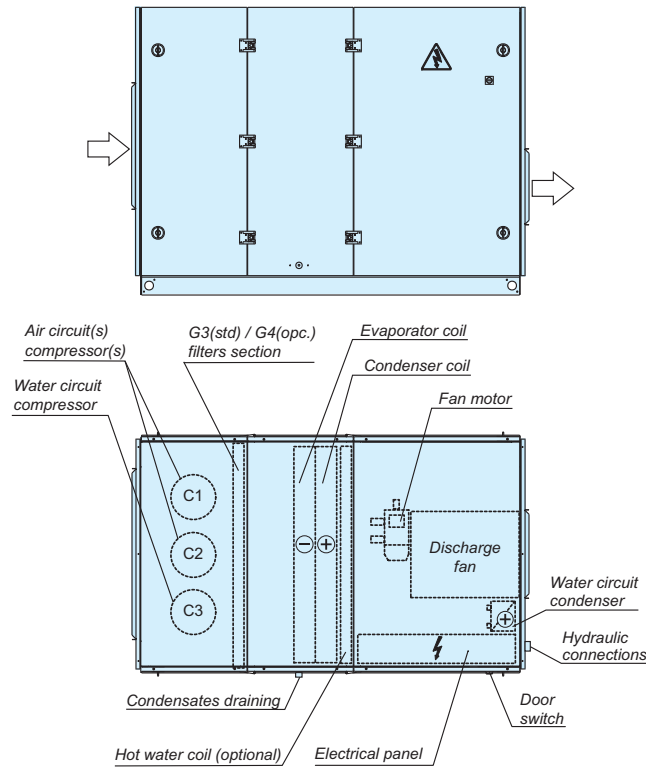

Aquair BCP with bags filter module and mixing box with 3 dampers with return fan

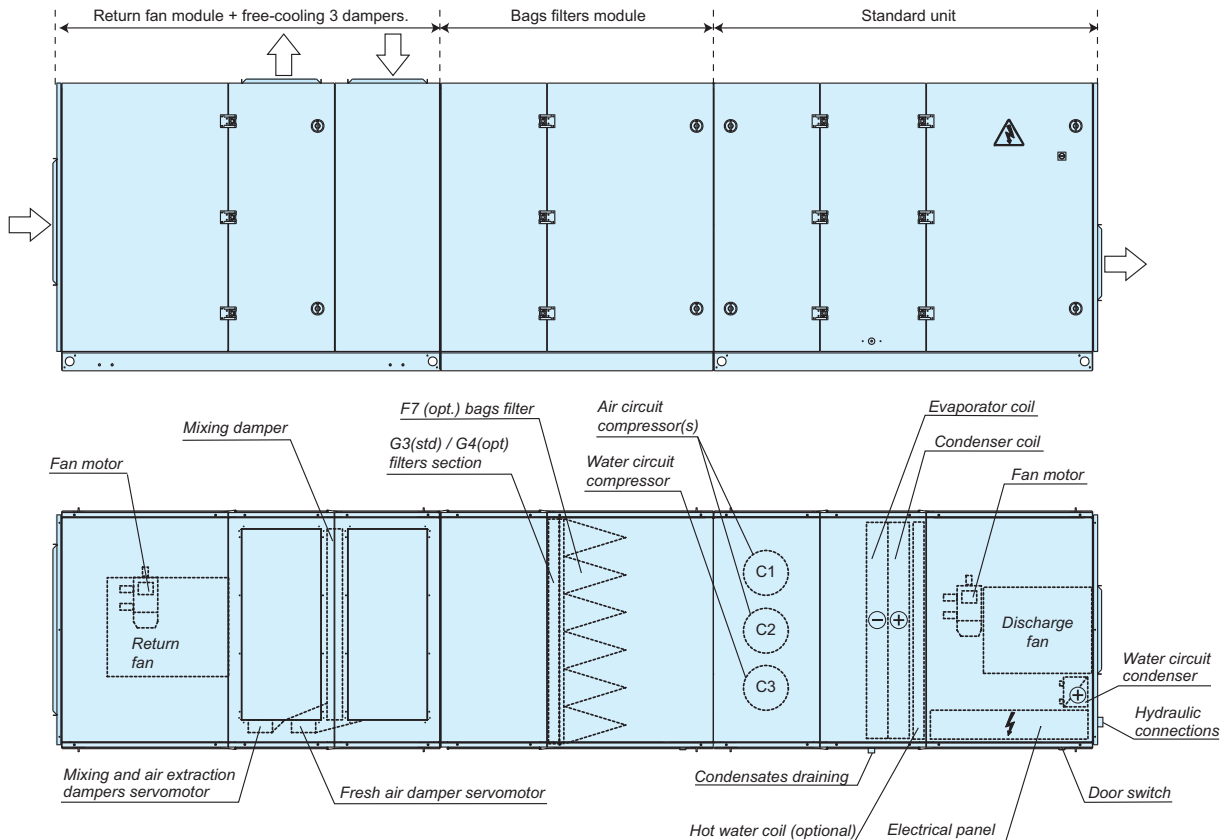

Note: in any configuration with bags filter module, the position of the gravimetric filters changes, locating itself in front of the bags filter (in the sense of the air flow)

14. MAINTENANCE

The minimal maintenance operations and their periodicity will be made according to the national regulations.

Any intervention on the electric cooling components must be made by a qualified and authorized technician.

Technicians who intervene with the unit must use the necessary safety equipment (gloves, goggles, insulating clothing, safety shoes, etc.).

Furthermore, if working around sources of significant noise, we recommend the use of noise-dampening headgear.



Caution: Before intervening in the unit, cut off main power.

A control of corrosion of metallic surfaces of the unit must be performed (chassis, casing, exchangers, electrical panel, etc). It should also be checked the status of electrical connections, as well as the watertightness of the different circuits.

Refrigerant

Qualified personnel must check periodically the watertightness depending on the refrigerant load, according to Regulation (CE) N°842/2006.

IMPORTANT: It is important not forget that the cooling systems contain liquids and vapors under pressure.

- Take the necessary cautions during the partial opening of the cooling circuit. This opening means the discharge of a certain quantity of refrigerant to the atmosphere. It is important to limit to the minimum the lost refrigerant, pumping and isolating the load in other part of the circuit.
- The liquid refrigerant at low temperature can cause inflammatory lesions similar to those burns on contact with skin or eyes. Use always protection glasses, gloves, etc. when you open pipes that may contain liquids.
- Excessive refrigerant must be stored in appropriate containers and the quantity of refrigerant stored in the plant rooms must be limited.
- Refrigerant bottles and tanks should be handled with care and the relevant notices should be displayed in full view so as to make everyone aware of the risks of intoxication, fire and explosion attaching to the refrigerant.
- At the end of its lifespan, the refrigerant should be recovered and recycled in accordance with current regulations.

The following graphs show the main accesses to the unit for cleaning and maintenance operations:

Access to discharge fan:

- In first place, put the door switch in 0 position.
- Later, turn the locks of the fan access door. The fan is also protected with a second screwed door that must be removed.

Recommendations:

- Check that the turbine and the motor are clean.
- Provide spare fan belts.
- The motor and fan have lubricated and sealed bearings and that, therefore do not need more lubrication.



Access to return fan (optional):

- In first place, put the door switch in 0 position.
- Later, turn the locks of the fan access door. The fan is also protected with a second screwed door that must be removed.
- Follow the same maintenance recommendations as for the discharge fan.



Access to water condenser

Access to plates exchanger through access door to discharge fan.

Recommendations:

- In the case of a longer standstill, leave the exchanger full of water pool without flowing or empty may cause corrosion problems. During periods of inactivity it is **mandatory** to fill up the hydraulic circuit of the exchanger completely with demineralised water. To isolate the hydraulic circuit of the rest of the installation, the installer must have shut-off valves at the input and output, and a drain for emptying.

Access to electrical panel

- In first place, put the door switch in 0 position.
- Later, turn the locks of the door where we will find this switch. The electrical panel is located on the upper part.



Access to condensates drain pan

Access to condensates drain pan through compressors access panel. To reach the pan, the filters should be disassembled (except in units with bags filter module).

Recommendations:

- Check that condensates drain pan is clean. As this pan is sloped towards the drainage, water should not remain stagnant.
- Check that the drainage is not obstructed.
- Wash the pan with water and non abrasive detergent.

Air filter extraction

For units with no bags filter, the access to the filters is made through the same access door to compressors.

In these units, filters extraction is lateral. Simply pull the filter tabs slightly forward to remove the filter. In the following detail appears a filter displaced for removing it:



For units with bags filter, the access to filters is made through the access door to this module.

In these units filter extraction is lateral. Simply pull the filter tabs slightly forward to remove the filter.

Gravimetric filters frame (G3/G4)

Opacimetric filters frame (F7)



Recommendations:

- Clean it regularly. Depending on the installation conditions, the state of the filter should be checked to define cleaning periodicity.
- G3 (standard) and G4 (optional) filters: Clean the filter with a vacuum cleaner or by immersion in water.
- F7 (optional) filters: Should be replaced. Provide spare bags.

15. CONTROL AND ANALYSIS OF BREAKDOWNS

Symptom	Cause	Solution
Evaporation pressure very high in relation with the air inlet	<ul style="list-style-type: none"> a) Charge excess b) High air temperature c) Compressor suction not air tight d) Cycle reversing valve in middle position 	<ul style="list-style-type: none"> a) Collect refrigerant b) Verify overheating c) Verify compressor state and replace d) Check that the valve is not clogged. Replace if necessary
Very low condensation pressure	<ul style="list-style-type: none"> a) Gas lack b) Compressor suction not air tight c) Cycle inversion valve in middle position d) Liquid circuit plugging 	<ul style="list-style-type: none"> a) Search for leaks, complete charge b) Verify compressor state and replace c) Check that the valve is not clogged. Replace if necessary d) Verify the dehydrating filter and expansion valve
Condensation pressure very high in relation to the air outlet, high pressostat cutoff	<ul style="list-style-type: none"> a) Insufficient air flow b) Air inlet temperature very high c) Dirty condenser (does not exchange) d) Much refrigerant load (flooded condenser) e) The condenser fan is broken down f) Air in the cooling circuit 	<ul style="list-style-type: none"> a) Verify the air circuits (flow, filter cleanliness...) b) Verify the control thermostat readjustment c) Clean it d) Collect refrigerant e) Repair f) Make vacuum and load
Evaporation pressure too low (low pressostat cut-off)	<ul style="list-style-type: none"> a) Low flow in evaporator. Air recirculation b) Frozen evaporator c) Liquid line as different temperatures at filter inlet and outlet d) Gas lack e) Very low condensation pressure f) Evaporator fan broken down 	<ul style="list-style-type: none"> a) Verify the air circuits (flow, filter cleanliness...) b) Verify defrost c) Replace filter d) Search for leaks, complete charge e) Temperature of air or water in condenser very low (air or water flow very high), adjust flow f) Repair
Compressor does not start, does not make noise (humming)	<ul style="list-style-type: none"> a) No power b) The contacts of a control element are open c) Timing of anti cycle short does not allow the starting d) Open contact e) Contactor coil burnt f) Indoor klixon open 	<ul style="list-style-type: none"> a) Check differential, fuses b) Verify the safety chain of the electronic control c) Verify electronic control d) Replace e) Replace f) Wait for reactivation, verify current absorbed
Compressor does not start, motor sounds intermittently	<ul style="list-style-type: none"> a) Electrical power supply very low b) Power cable disconnected 	<ul style="list-style-type: none"> a) Control line voltage and locate voltage drop b) Verify connections
Repeated compressor starts and stops	<ul style="list-style-type: none"> a) Because of high pressure b) Control differential too short (short cycle) c) Insufficient gas, cut-off because of low pressure d) Dirty or frosted evaporator e) The evaporator fan does not work, cuts off the low pressostat f) Expansion valve damaged or clogged by impurities (cuts off low pressostat) g) Dehydrating filter clogged (cuts off low safety) 	<ul style="list-style-type: none"> a) Verify charge b) Increase differential c) Search for leak, reload unit d) Clean, verify evaporator air circuit e) Replace or repair f) Replace, as well as filter g) Replace
The compressor makes a noise	<ul style="list-style-type: none"> a) Loose attachment b) Oil lack c) Compressor noise 	<ul style="list-style-type: none"> a) Fix b) Add oil to recommended level c) Replace
Noisy operation	<ul style="list-style-type: none"> a) Unit installed without antivibration protection 	<ul style="list-style-type: none"> a) Place base over shock absorbers
Cycle reversing is not carried out: - No defrosting - Does not change winter - summer cycles	<ul style="list-style-type: none"> a) Electrical fault b) Inversion valve coil defective c) Defrost method not working d) Cycle inversion valve in middle position e) Control fault 	<ul style="list-style-type: none"> a) Locate and repair b) Replace c) Verify parameters d) Tap with running compressor. Replace if necessary e) Locate and repair
Alarm or reading error in the humidity probe	<ul style="list-style-type: none"> a) Dirt in the humidity sensor 	<ul style="list-style-type: none"> a) Disassembly the probe capsule b) Proceed to clean the sensor with some soft cotton element and non-abrasive fluid, without pressing it c) Reassemble the casing, checking that the cable is in contact externally with the metallic mesh

