

Energy excellence

Eurovent-certified class A EER

SEER up to 4.5, SEPR up to 6.3

Operating range from -20 °C to +55 °C

Compact and silent

High-efficiency flooded shell and tube evaporator

Aluminium micro-channel condenser

Hydraulic module & heat recovery

Cooling capacity: 273 to 1493 kW



Cooling only



Hydraulic module



Heat recovery



USE

The latest generation of **POWERCIAT** high-efficiency air-to-water water chillers are the perfect solution for all cooling applications in the Offices, Healthcare, Industry, Administration, Shopping Centres and Collective Housing markets.

These units are designed for outdoor installation and require no special protection against adverse weather conditions.

POWERCIAT is optimised to use ozone-friendly HFC R134a refrigerant.

This range guarantees compliance with the most demanding requirements for increased seasonal energy efficiency (SEER and SEPR) and CO₂ reduction to comply with the various applicable European directives and regulations.

RANGE

POWERCIAT series LX ST

Standard cooling only version.

The product is optimised to meet the most demanding technical and economic requirements, as well as fulfilling the provisions of the new Ecodesign regulation governing process applications.

POWERCIAT series LX XE

Premium cooling only version.

The product is optimised for part load applications and fulfils the provisions of the new Ecodesign regulation governing comfort and process applications, while also facilitating a return on investment. In this case, the machine is equipped with EC-type variable-speed fans as standard, enabling the optimum part load efficiency to be achieved throughout the year

POWERCIAT series LX HE

Cooling only version High seasonal energy efficiency.

The product is optimised for part load applications and fulfils the provisions of the new Ecodesign regulation governing comfort and process applications. In this case, the machine is equipped as standard with variable-speed fans with AC motor and external speed regulator, allowing for optimisation of the part load efficiency throughout the year.

DESCRIPTION

POWERCIAT units are packaged machines supplied as standard with the following components:

- Twin-screw semi-hermetic compressors
- Flooded shell and tube type chilled-water evaporator
- Air-cooled exchanger, all-aluminium micro-channel coil with axial fan motor assembly
- Electrical power and remote control cabinet:
 - 400 V-3ph-50 Hz (+/-10%) mains power supply + earth
 - transformer fitted as standard on the machine for supplying the remote control circuit with 24V
- Connect Touch electronic control module
- Casing for outdoor installation

The entire POWERCIAT range complies with the following EC directives and standards:

- Machinery directive 2006/42/EC.
- Electromagnetic compatibility directive 2014/30/EU.
- EMC immunity and emissions EN 61800-3 'C3'
- Low voltage directive 2014/35/EU.
- RoHS 2011/65/EU
- Pressure equipment directive (PED) 2014/68/EU
- Machinery directive EN 60-204 - 1
- Refrigeration systems and heat pumps EN 378-2
- Regulation (EU) no. 2016/2281 implementing directive 2009/125/EC with regard to Ecodesign requirements

DESIGNATION

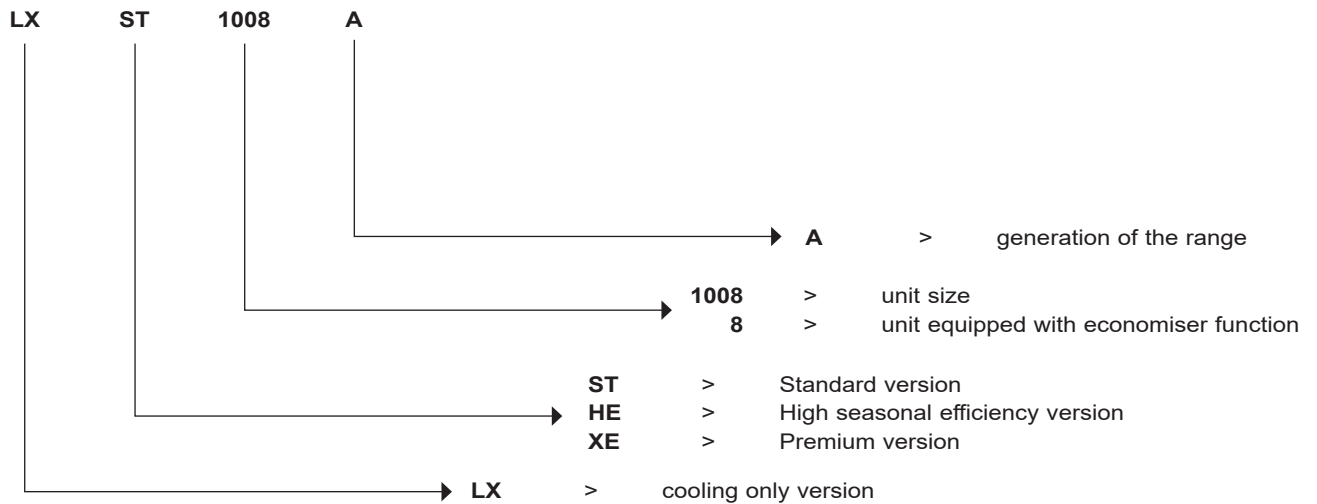

CONFIGURATION

ST	Standard	HE	High Seasonal Efficiency
ST LN option	Standard Low Noise	HE LN option	High Seasonal Efficiency Low Noise
ST XLN option	Standard Xtra Low Noise	HE XLN option	High Seasonal Efficiency Xtra Low Noise
ST SLN option	Standard Super Low Noise	HE SLN option	High Seasonal Efficiency Super Low Noise
XE	Premium		
XE LN option	Premium Low Noise		
XE XLN option	Premium Xtra Low Noise		

DESCRIPTION OF THE MAIN COMPONENTS

■ Compressors

- Twin-screw semi-hermetic type
- 2 screws fitted on ball and roller bearings
- Continuous power control
- Built-in electric motor, cooled by intake gases
- Integral electronic protection of the motor against thermal and electrical overloads
- Monitoring of rotation direction, absence of phase, over and under voltage, and power supply failure
- Monitoring of lubrication under differential pressure
- Built-in oil filter
- Internal pressure surge valve and valve to prevent reverse rotation during shutdown phases
- Monitoring of maximum head pressure
- Oil separator with integrated silencer to reduce pulses from the discharged gas
- Star-delta start limiting the in-rush current

■ Shell and tube evaporator

- High performance glandless technology
- Copper tube bundle with internal and external grooves
- 19 mm thermal insulation
- Victaulic type coupling
- Maximum pressure, water side, of 10 bar (**21 bar as option**)

■ Condenser

- air-cooled exchanger, all-aluminium micro-channel coil
- Propeller fans with composite blades offering an optimised profile, fixed speed (ST version) or variable speed (HE and XE versions)
- Motors – IP 54, class F

■ Refrigerant accessories

- Dehumidifier filters with rechargeable cartridges
- Hygroscopic sight glasses
- Electronic expansion valves
- Service valves on the liquid line

■ Regulation and safety instruments

- Low and high pressure sensors
- Safety valves on refrigerant circuit
- Water temperature control sensors
- Evaporator antifreeze protection sensor
- Factory-fitted evaporator water flow controller

■ Electrical cabinet

- Electrical cabinet protection rating: IP44 (IP54 optional)
- A connection point without neutral for sizes 808 to 3028
- Two connection points without neutral for sizes 3428 to 4608 (one connection point optional)
- Front-mounted main safety switch with handle
- Control circuit transformer
- 24V control circuit
- Fan and compressor motor circuit breaker
- Fan and compressor motor contactors
- Connect Touch microprocessor-controlled electronic control module
- Wire numbering
- Marking of the main electrical components

■ Frame

Frame made from RAL 7035 light grey & RAL 7024 graphite grey painted panels

■ Connect Touch control module

- User interface with 5 inch touchscreen
- Intuitive, user-friendly navigation using icons
- Clear text display of information available in 9 languages (F - G B - D - N L - E - I - P - R U + Chinese)



The electronic control module performs the following main functions:

- Regulation of the chilled water temperature (at the return or at the outlet)
- Regulation of the water temperature based on the outdoor temperature (water law)
- Regulation for low temperature energy storage
- Second setpoint management
- Complete management of compressors with start-up sequence, timer and runtime balancing
- Self-regulating and proactive functions with adjustment of the control to counter parameter drift
- In-series staged power control system on the compressors according to the thermal requirements
- Management of compressor short-cycle protection
- Frost protection (exchanger heater option)
- Phase reversal protection
- Management of occupied/unoccupied modes (according to the time schedule)
- Compressor and pump runtime balancing
- Management of the machine operating limit according to outdoor temperature
- Sound level reduction device (night mode according to the user programme) with limitation of compressor capacity and fan speed
- Diagnosis of fault and operating statuses
- Management of a fault memory allowing a log of the last 50 incidents to be accessed, with operating readings taken when the fault occurs
- Blackbox memory
- Master/slave management of the two machines in parallel with runtime balancing and automatic changeover if a fault occurs on one machine
- Weekly and hourly time schedule for the machine, including 16 periods of absence
- Pump standby based on demand (energy saving)
- Calculation of the water flow rate and operating pressure (hydraulic module version)
- Display of all machine parameters (3 access levels, User/Maintenance/Factory, password-protected): temperature, setpoints, pressures, water flow rate (hydraulic version), runtime.
- Display of trend curves for the main values
- Storage of maintenance manual, wiring diagram and spare parts list.

■ Remote management

Connect Touch is equipped as standard with an RS485 port and an ETHERNET (IP) connection, offering a range of options for remote management, monitoring and diagnostics.

Using the integrated Webserver, a simple internet connection uses the unit's IP address to access the Connect Touch interface on the PC, facilitating everyday management tasks and maintenance operations.

A range of communication protocols are available: MODBUS/ JBUS RTU (RS485) or TC/IP as standard, LONWORKS – BACNET IP as an option, enabling most CMS/BMS to be integrated

Several contacts are available as standard, enabling the machine to be controlled remotely by wired link:

- Automatic operation control: when this contact is open, the machine stops
- Setpoint 1/setpoint 2 selector: when this contact is closed, a second cooling setpoint is activated (energy storage or unoccupied mode, for example)
- Power limitation: closing the contact concerned allows the power or refrigerating consumption of the machine to be limited by stopping one or more compressors (this limit can be set with a parameter)
- Fault reporting: this contact indicates the presence of a major fault which has caused one or both refrigerant circuits to stop
- Operational status reporting indicates that the unit is in production mode.
- Switch control for the customer pump, external to the machine (on/off).

Contacts available as an option:

- Setpoint adjustable via 4-20 mA signal: this input is used to adjust the setpoint in COOLING mode
- Power limitation adjustable by 4-20 mA signal
- Second power limitation level
- Power indication: analogue output (0-10 V) providing an indication of the unit's load rate.
- User fault reporting enables integration of a fault in the water loop
- General fault reporting: this contact indicates that the unit has stopped completely
- Alert reporting: this contact indicates the presence of a minor fault which did not cause the refrigerant circuit in question to stop.
- End of storage signal: enables return to the second setpoint at the end of the storage cycle
- Schedule override: closing this contact cancels the time schedule

■ Maintenance

Connect Touch has two maintenance reminder functions as standard, making users aware of the need to regularly perform maintenance operations and to guarantee the service life and performance of the unit. These two functions can be activated independently.

A reminder message appears on the unit's HMI screen, and stays there until it is acknowledged by the maintenance operator. The information and alert relating to these functions are available on the communication bus to be used on the CMS/BMS.

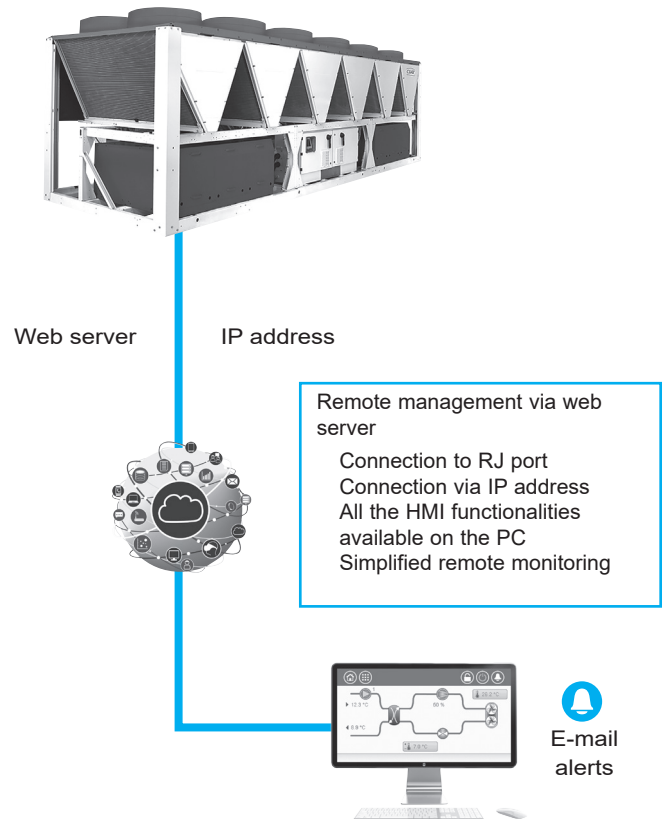

- The scheduled maintenance reminder: when activated, this function enables the period between two maintenance inspections to be set. This period may be set by the operator in either days, months or operating hours, depending on the application.
- The compulsory F-GAS sealing test maintenance reminder: when activated, this function, which is the default factory setting, enables the period between two sealing tests to be selected, according to the unit's refrigerant charge, in compliance with the F-GAS regulations.

■ CIATM2M, the CIAT supervision solution

CIATM2M is a remote supervision solution dedicated to monitoring and controlling several CIAT machines in real time.

Advantages

- Access to the operating trend curves for analysis
- Improved energy performance
- Improved availability rate for the machines

Functions

CIATM2M will send data in real time to the supervision website, www.ciatm2m.com.

The machine operating data can be accessed from any PC, smartphone or tablet.

Any event can be configured to trigger a mail alert.

Parameters monitored:

- Overview screen
- Control panel for the controllers
- Events
- Temperature curves

Monthly and annual reports are available to analyse:

- The performance and operation of the machine
Example: operating curves and time, number of compressor start-ups, events, preventive maintenance actions to be performed, etc.
- The electricity consumed (if the energy meter option is present)

Incidents such as a drift in the measurements on a temperature sensor, incorrectly set control parameters, or even incorrect settings between one compressor stage and the other are immediately detected, and the corrective actions put in place.

Equipment

This kit can be used on both machines which are already in use (existing inventory), and on new machines which do not have sufficient space in their electrical cabinets.

- 1 transportable cabinet
- 1 wall-mounted antenna

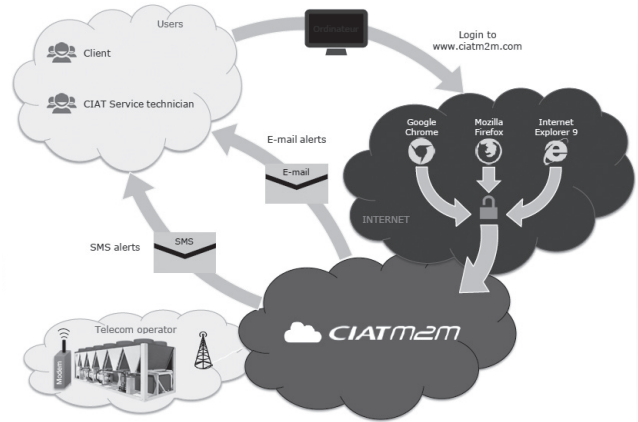

CIATM2M kit contents

- 1 GPRS / 3G modem
- 1 SIM card
- 1 24-VDC power supply
- 1 power protection device
- 1 GSM antenna
- Rail mounting
- Enclosed casing to protect the equipment during transport
- Packing box for cable routing (bus, power supply, Ethernet)

Compatibility

Up to three machines per CIATM2M kit

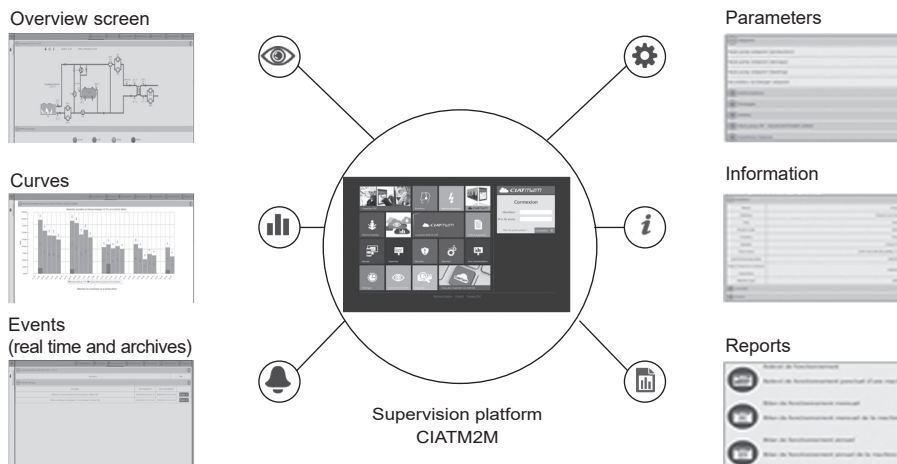

AVAILABLE OPTIONS

Options	Description	Advantages	LX ST/HE/XE
Medium-temperature brine solution	Implementation of new algorithms of control and evaporator redesign to allow chilled brine solution production down to -6°C when ethylene glycol is used (-3°C with propylene glycol)	Covers specific applications such as ice storage and industrial processes	•
Low-temperature brine solution	Implementation of new algorithms of control and evaporator redesign to allow chilled brine solution production down to -12°C when ethylene glycol is used (-8°C with propylene glycol)	Covers specific applications such as ice storage and industrial processes	•
Light-brine solution, down to -3°C	Implementation of new algorithms of control to allow chilled brine solution production down to -3°C when ethylene glycol is used (0°C with propylene glycol)	Matches with most application requirements for ground-sourced heat pumps and fits with many industrial processes requirements	•
Unit equipped for air discharge ducting	Fans equipped with discharge connection flanges - maximum available pressure 60 Pa	Facilitates connections to the discharge ducts	•
Low Noise	Aesthetic and sound absorbing compressor enclosure	Noise level reduction	•
Xtra Low Noise	Acoustic compressor enclosure and low-speed fans	Noise emission reduction at reduced fan speed	•
Super Low Noise	Acoustic compressor enclosure, low-speed fans and enhanced sound insulation of main noise sources	Noise level reduction in sensitive environments	ST/HE version sizes 1308 to 4608
IP54 control box	Increased leak tightness of the unit	Protects the inside of the electrical box from dust, water and sand. As a rule, this option is recommended for installations located in polluted environments	•
Tropicalisation of the electrical box	Electrical box equipped with an electrical heater and a fan. Electrical connections on the compressors painted with a special varnish and covered with an anti-condensation foam.	Grant safe operation in typical "tropical" climate. This option is recommended for all applications where humidity inside the electrical box can reach 80% at 40°C and unit can remain in stand-by for a long time under this conditions.	•
Protection grilles	Metal grilles on the 4 unit sides.	Improves protection against intrusion to the unit interior, and protects the coil and piping against impacts.	•
Winter operation down to -20 °C	Fan speed control via frequency converter	Stable unit operation for air temperature down to -20 °C	ST version, all sizes
230 V electrical plug	230 V AC power supply source provided with plug socket and transformer (180 VA, 0.8 A)	Permits connection of a laptop or an electrical device during unit commissioning or servicing	•
Water exchanger frost protection	Electric resistance heater on the water exchanger and discharge valve	Water exchanger frost protection down to -20°C outside temperature	•
Evaporator & hydraulic module frost protection	Electric resistance heater on water exchanger, discharge valve and hydraulic module	Water exchanger and hydraulic module frost protection down to -20°C outside temperature	Sizes 808 to 1528
Total heat recovery	Unit equipped with additional heat exchanger in parallel with the condenser coils.	Production of free hot-water simultaneously with chilled water production	Sizes 808 to 3028
Evaporator with one pass less	Evaporator with one pass on the water side. Evaporator inlet and outlet on opposite sides.	Easy to install, depending on site. Reduced pressure drops	Sizes 808 to 3028
Master/slave operation	Unit equipped with supplementary water outlet temperature sensor kit to be field installed allowing master/slave operation of two units connected in parallel	Optimised operation of two units connected in parallel operation with operating time equalisation	•
21 bar evaporator	Reinforced evaporator for extension of the maximum water-side service pressure to 21 bar (standard 10 bar)	Covers applications with a high water column evaporator side (typically high buildings)	•
Single power connection point	Unit power connection via one main supply connection	Quick and easy installation	Sizes 3428 to 4608
Reversed evaporator water connections	Evaporator with reversed water inlet/outlet	Easy installation on sites with specific requirements	•
Service valve set	Liquid line valve (evaporator inlet), compressor suction and discharge line valves and economiser line valve	Allow isolation of various refrigerant circuit components for simplified service and maintenance	•
Evaporator with one pass more	Evaporator with one pass more on the water side	Optimise chiller operation when the chilled water circuit is designed with low waterflows (high delta T evaporator inlet/outlet)	•
Lon gateway	Two-directional communication board complying with Lon Talk protocol	Connects the unit by communication bus to a building management system	•

• ALL MODELS

Refer to the selection tool to find out which options are not compatible.

AVAILABLE OPTIONS

Options	Description	Advantages	LX ST/HE/XE
HP single-pump hydraulic module	Complete hydraulic module equipped with water filter, relief valve, one high pressure pump and drain valve. For more details, refer to the dedicated chapter (expansion tank not included; option with built-in safety hydraulic components available).	Quick and easy installation (plug & play)	Sizes 808 to 1528
HP dual-pump hydraulic module	Dual high pressure water pump, water filter, electronic water flow control, pressure transducers. For more details, refer to the dedicated chapter (expansion tank not included; option with built-in safety hydraulic components available)	Quick and easy installation (plug & play)	Sizes 808 to 1528
LP single-pump hydraulic module	Single low pressure water pump, water filter, electronic water flow control, pressure sensors. For more details, refer to the dedicated chapter (expansion tank not included; option with built-in safety hydraulic components available)	Quick and easy installation (plug & play)	Sizes 808 to 1528
LP dual-pump hydraulic module	Dual low pressure water pump, water filter, electronic water flow control, pressure sensors. For more details, refer to the dedicated chapter (expansion tank not included; option with built-in safety hydraulic components available)	Quick and easy installation (plug & play)	Sizes 808 to 1528
Dual relief valves on 3-way valve	Three-way valve upstream of dual relief valves on the shell and tubes evaporator	Valve replacement and inspection facilitated without refrigerant loss. Comforms to European standard EN378/BGVD4	Sizes 808 to 3028
Compliance with Swiss regulations	Additional tests on the water heat exchangers: supply (additional of PED documents) supplementary certificates and test certifications	Conformance with Swiss regulations	•
Compliance with Russian regulations	EAC certification	Compliance with Russian regulations	•
Bacnet over IP	Bi-directional high-speed communication using BACnet protocol over Ethernet network (IP)	Easy, high-speed connection by Ethernet line to a building management system. Allows access to multiple unit parameters	•
Energy Management Module	Control board with additional inputs/outputs. See Contacts available in option on control description.	Extended remote control capabilities (setpoint reset by 0-20 mA input, ice storage end, demand limits, boiler on/off command...)	•
7" user interface	Control supplied with a 7 inch colour touch screen user interface	Enhanced ease of use.	•
Input contact for Refrigerant leak detection	0-10 V signal to report any refrigerant leakage in the unit directly on the controller (the leak detector itself must be supplied by the customer)	Immediate customer notification of refrigerant losses to the atmosphere, allowing timely corrective actions	•
Compliance with Australian regulations	Unit approved to Australian code	Conformance with Australian regulations	•
Power factor correction	Capacitors for automatic correction of power factor (cos phi) value to 0.95.	Reduction of the apparent electrical power, compliance with minimum power factor limit set by utilities	Sizes 808 to 3028
Insulation of the evap. in/out ref.lines	Thermal insulation of the evaporator entering/leaving refrigerant lines with flexible, UV resistant insulation	Prevents condensation on the evaporator entering/leaving refrigerant lines	•
MCHE anti-corosion protection Protect2	Coating by conversion process which modifies the surface of the aluminium producing a coating that is integral to the coil. Complete immersion in a bath to ensure 100% coverage. No heat transfer variation, salt spray resistance test for 4000 hours (ASTM B117)	Protect2 Improved corrosion resistance of the MCHE coils by 2, recommended for use in moderately corrosive environments	•
MCHE anti-corosion protection Protect4	Extremely durable and flexible epoxy polymer coating applied on micro channel coils by electro coating process, final UV protective topcoat. Minimal heat transfer variation, tested 6000 hours constant neutral salt spray per ASTM B117, superior impact resistance per ASTM D2794	Protect4 Improved corrosion resistance of the MCHE coils by 4, recommended for use in corrosive environments	•
Evaporator with aluminium jacket	Evaporator covered with an aluminium sheet for thermal insulation protection	Improved resistance to aggressive climate conditions	•
Expansion tank	6 bar expansion tank integrated in the hydraulic module (requires hydraulic module option)	Easy and fast installation (plug & play), & protection of closed water systems from excessive pressure	Sizes 808 to 1528

• ALL MODELS
Refer to the selection tool to find out which options are not compatible.

SEASONAL PERFORMANCE

Most central air conditioning systems installed in the tertiary sector in Europe use water chillers to provide refrigeration. Analyses of installed systems show that the heat load varies from season to season and that a water chiller operates at reduced capacity for the majority of the time.

The efficiency under partial load is therefore essential when choosing a water chiller. It is with this in mind that the new POWERCIAT range was designed. In particular, the entire range uses R134a refrigerant which, thanks to its thermodynamic performance, makes it possible to obtain much higher seasonal performance ratings.

Thanks to its system continuously regulating the power of each compressor, the POWERCIAT easily and efficiently adjusts the cooling capacity to the system's needs. The self-adjusting Connect Touch control anticipates variations in load and starts only the number of compressors needed. This ensures optimum operation of the compressors and guarantees energy efficiency for the majority of the system's life.

The Premium version of the POWERCIAT XE series has EC-type variable-speed fan motor assemblies as standard. This type of fan motor with electronic switching of poles and rotors with permanent magnets stands out for its excellent mechanical efficiency and its exceptionally low sound level, whatever the load on the shaft. This technology optimises the machine's seasonal performance (SEER and SEPR) through the most effective means all year round.

The **Seasonal Energy Efficiency Ratio (SEER)** measures the seasonal energy efficiency of liquid chillers **for comfort applications** by calculating the ratio between the annual cooling demand of the building and the chiller's annual energy demand. It takes into account the energy efficiency for each outdoor temperature weighted by the number of hours observed for each of these temperatures, using actual climate data. The **SEER** is a new way of measuring the energy efficiency of liquid chillers for **comfort applications** over an entire year. The new indicator provides a more realistic overview of the cooling system's energy efficiency and its actual impact on the environment. (Ecodesign regulation 2016/2281).

The **Seasonal Energy Performance Ratio (SEPR)** measures the seasonal energy efficiency of liquid chillers for **process applications** by calculating the ratio between the annual process cooling demand and the chiller's annual energy demand. It takes into account the energy efficiency at each outdoor temperature for the average European climate weighted by the number of hours observed for each of these temperatures.

The **SEPR** is a new way of measuring the energy efficiency of liquid chillers for **process applications** over an entire year. The new indicator provides a more realistic overview of the cooling system's energy efficiency and its actual impact on the environment (Ecodesign regulation 2015/1095 or 2016/2281).

HYDRAULIC MODULE

■ The "ALL IN ONE" solution

The PLUG & COOL solution offered by POWERCAT

The hydraulic module available for models 808 to 1528 contains all the water circuit components needed for the system to operate correctly:

- Expansion vessel (option):
 - 50 litres for models 808 to 1358.
 - 80 litres for model 1528.
- Wide choice of pumps:
 - Single or dual pumps with runtime balancing and backup.
 - Fixed-speed high or low pressure pumps.
- Water temperature and pressure sensors.
- Water filter.
- Relief valve.
- Drain circuit.
- Air bleed valve.
- Frost protection (option).

The components in the hydraulic system are carefully selected and factory assembled and tested to make the installation of the units simple and economical.

This ensures conditioning times, implementation times and space requirements are kept to a minimum.

■ POWERCAT hydraulic module diagram

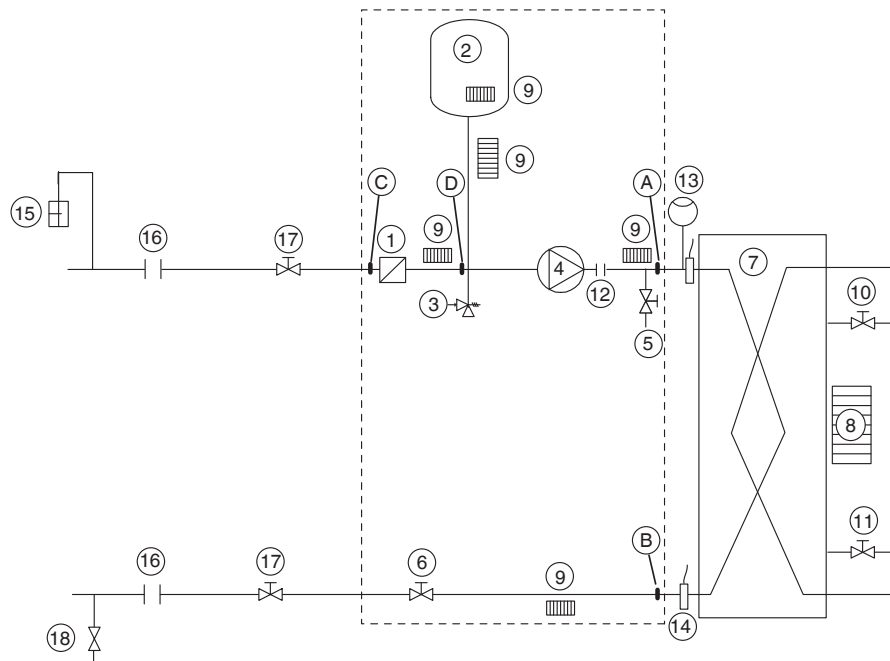

Key

Components of the unit and hydraulic module

- | | |
|---|---|
| A Pressure sensor (A-B = ΔP evaporator) | 6 Flow control valve |
| B Pressure sensor | 7 EVAPORATOR |
| A Pressure sensor (C-D = ΔP water filter) | 8 Evaporator antifreeze heater (optional) |
| D Pressure sensor | 9 Hydraulic module defrost heater (option) |
| 1 Victaulic screen filter | 10 Air vent (evaporator) |
| 2 Expansion tank (optional) | 11 Water drain (evaporator) |
| 3 Relief valve | 12 Expansion compensator (flexible connections) |
| 4 Available pressure pump | 13 Flow rate sensor |
| 5 Drain valve | 14 Water temperature sensor |

System components

- | |
|--|
| 15 Air vent |
| 16 Flexible |
| 17 Stop valve |
| 18 Charge valve |
| --- Hydraulic module (supplied as an option) |

ENVIRONMENTAL RESPONSIBILITY

The POWERCIAT contributes to sustainable development via an environmentally responsible approach, aimed at balancing ecological and economic concerns. This enables it to meet the requirements of future European thermal regulations and to protect our environment for future generations.

The highly efficient performance it offers enables energy consumption to be greatly reduced, thereby reducing the unit's carbon footprint throughout its service life.

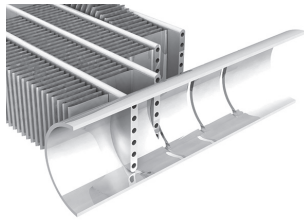

Only 20% of a unit's impact on the ozone layer comes from the refrigerant (direct effect), with 80% coming from the CO₂ released into the atmosphere when the electricity required to power the unit is produced (indirect effect). With POWERCIAT, it's a win-win situation: its low refrigerant charge minimises the risk of emissions, and its low energy consumption limits its indirect impact.

This performance is the result of the high quality components used, which have all been rigorously selected:

- The latest generation screw compressors
- Highly efficient R134a refrigerant, which has a low environmental impact: zero ODP (Ozone Depletion Potential), low GWP (Global Warning Potential).
- MCHE micro-channel coils
 - Energy efficiency increased by 10% compared to a conventional coil
 - 40% reduction in the refrigerant charge.
 - Reduction in the unit weight, reducing the environmental impact during transportation
 - Simplified end of life recycling thanks to the all-aluminium construction.

The choice of technology used in the POWERCIAT range means that the TEWI, which covers the unit's environmental impact (both direct and indirect) throughout its service life, is greatly reduced.

INTEGRATION INTO THE MOST DEMANDING ENVIRONMENTS

The POWERCIAT has standard and optional equipment which enables it to be integrated into any one of a diverse range of environments.

In the micro-channel (MCHE) coil, the rate of corrosion is less than in a conventional coil with copper tube and aluminium fins. Indeed, its all-aluminium design limits the galvanic couples in the coil, thereby providing increased corrosion resistance.

The Protect2 anti-corrosion post-treatment option doubles its resistance to corrosion. This treatment is applied by immersing the coil, ensuring complete protection as the aluminium surface undergoes a chemical change.

This treatment is recommended for moderately corrosive environments.

The Protect4 anti-corrosion post-treatment option provides a fourfold increase in resistance to corrosion. An e-coating process is used to electro-coat the coil in polymer epoxy, and then a top layer of anti-UV protection is applied.

This treatment is recommended for highly corrosive industrial and marine environments.

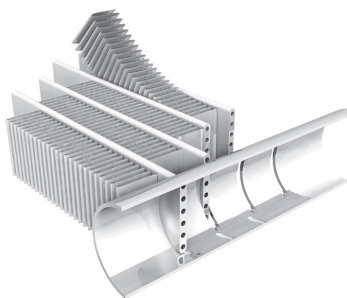

Protect2

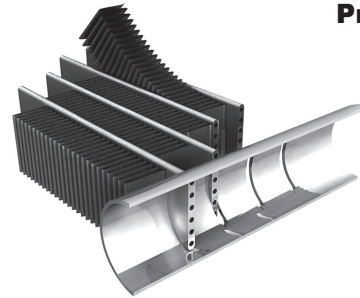

Protect4

In a polluted atmosphere, the POWERCIAT can be equipped with an IP54 protection option that protects the electrical components from the ingress of dust, sand and water.

TECHNICAL SPECIFICATIONS



POWERCIAT LX ST-HE		0808	0908	1008	1108	1358	1528	1858	2008	2158	
Cooling											
LX ST standard	Nominal capacity	kW	273	298	325	391	442	499	612	679	723
	Full load performances*	CA1 EER	kW/kW	3,13	3,10	3,09	3,21	3,08	3,15	3,13	3,31
Seasonal energy efficiency	Eurovent class		A	A	B	A	B	A	A	A	B
	SEER _{12/7°C} Comfort low temp.	kWh/kWh	4,14	4,18	4,25	-	-	4,10	-	4,23	-
	η _s cool _{12/7°C}	%	162	164	167	-	-	161	-	166	-
	SEPR _{12/7°C} Process high temp.	kWh/kWh	4,78	5,28	5,55	4,99	5,35	5,45	5,22	5,65	5,14
	SEPR _{-2/-8°C} Process medium temp.**	kWh/kWh	3,05	3,30	3,45	3,16	3,39	3,47	3,43	3,64	3,33
Part Load integrated values	IPLV.SI	kW/kW	4,313	4,366	4,565	4,376	4,513	4,512	4,351	4,637	4,397
LX ST with Xtra & Super Low Noise option	Nominal capacity	kW	267	291	318	378	426	473	601	654	691
	Full load performances*	CA1 EER	kW/kW	3,00	2,96	2,98	3,08	2,89	2,93	3,03	3,11
Seasonal energy efficiency	Eurovent class		B	B	B	B	C	B	B	A	B
	SEER _{12/7°C} Comfort low temp.	kWh/kWh	4,20	4,25	4,48	4,22	4,15	4,22	-	4,29	-
	η _s cool _{12/7°C}	%	165	167	176	166	163	166	-	168	-
	SEPR _{12/7°C} Process high temp.	kWh/kWh	5,24	5,41	5,96	5,30	5,45	5,52	5,61	5,82	5,33
	SEPR _{-2/-8°C} Process medium temp.**	kWh/kWh	3,03	3,55	3,73	3,42	3,54	3,62	3,70	3,84	3,53
Part Load integrated values	IPLV.SI	kW/kW	4,409	4,504	4,772	4,725	4,75	4,773	4,544	4,671	4,576
LX HE standard	Nominal capacity	kW	271	295	321	389	438	494	610	673	720
	Full load performances*	CA1 EER	kW/kW	3,13	3,10	3,06	3,23	3,04	3,13	3,14	3,30
Seasonal energy efficiency	Eurovent class		A	A	B	A	B	A	A	A	B
	SEER _{12/7°C} Comfort low temp.	kWh/kWh	4,35	4,41	4,38	4,29	4,14	4,26	4,10	4,43	4,11
	η _s cool _{12/7°C}	%	171	173	172	168	162	167	161	174	161
	SEPR _{12/7°C} Process high temp.	kWh/kWh	5,94	6,08	6,17	5,81	5,76	5,88	5,67	6,13	5,55
	SEPR _{-2/-8°C} Process medium temp.**	kWh/kWh	3,52	3,70	3,78	3,52	3,66	3,79	3,71	3,99	3,58
LX HE with Xtra & Super Low Noise option	Nominal capacity	kW	267	291	318	378	426	473	601	654	691
	Full load performances*	CA1 EER	kW/kW	3,03	2,98	3,00	3,11	2,90	2,95	3,05	3,13
Seasonal energy efficiency	Eurovent class		B	B	B	A	B	B	B	A	B
	SEER _{12/7°C} Comfort low temp.	kWh/kWh	4,30	4,34	4,52	4,30	4,19	4,27	4,10	4,35	4,10
	η _s cool _{12/7°C}	%	169	170	178	169	165	168	161	171	161
	SEPR _{12/7°C} Process high temp.	kWh/kWh	5,85	5,99	6,29	5,78	5,71	5,76	5,82	6,06	5,55
	SEPR _{-2/-8°C} Process medium temp.**	kWh/kWh	3,47	3,70	3,89	3,56	3,65	3,74	3,81	3,98	3,64
Sound levels											
LX ST-HE											
Sound power ⁽¹⁾	dB(A)	100	100	100	100	102	100	102	100	103	
Sound pressure at 10 m ⁽²⁾	dB(A)	68	68	68	68	70	68	69	68	71	
LX ST HE + Low Noise option											
Sound power ⁽¹⁾	dB(A)	94	94	95	96	96	96	98	96	98	
Sound pressure at 10 m ⁽²⁾	dB(A)	62	62	63	64	64	64	66	63	65	
LX ST-HE + Xtra low noise option											
Sound power ⁽¹⁾	dB(A)	87	87	87	90	91	91	93	92	93	
Sound pressure at 10 m ⁽²⁾	dB(A)	55	55	55	58	59	59	60	59	60	
LX ST-HE + Super low noise option											
Sound power ⁽¹⁾	dB(A)	-	-	-	-	89	89	91	90	91	
Sound pressure at 10 m ⁽²⁾	dB(A)	-	-	-	-	57	56	58	57	59	
Dimensions											
LX ST-HE											
Length	mm	3604	3604	3604	4798	4798	5992	7186	7186	7186	
Width	mm	2253	2253	2253	2253	2253	2253	2253	2253	2253	
Height	mm	2297	2297	2297	2297	2297	2297	2297	2297	2297	
Operating weight⁽³⁾											
LX ST standard	kg	3190	3224	3245	3834	3899	4261	4962	5093	5376	
LX ST Unit + low noise option	kg	3458	3492	3513	4133	4198	4560	5293	5424	5707	
LX HE standard	kg	3240	3274	3295	3934	3999	4411	5112	5293	5526	
LX HE Unit + Low noise option	kg	3508	3542	3563	4233	4298	4710	5443	5624	5857	

* In accordance with standard EN14511-3:2013.
 ** With low-temperature brine solution option
 CA1 Cooling mode conditions: evaporator water inlet/outlet temperature 12 °C/7 °C, outdoor air temperature 35 °C, evaporator fouling factor 0 m². kW
 η_s cool_{12/7°C} & SEER _{12/7°C} Applicable Ecodesign regulation (EU) No. 2016/2281
 SEPR _{12/7°C} Applicable Ecodesign regulation (EU) No. 2016/2281
 SEPR _{-2/-8°C} Applicable Ecodesign regulation (EU) No. 2015/1095
 IPLV.SI Calculated as per AHRI standard 551-591.
 (1) In dB ref=10⁻¹² W, 'A' weighted. Declared dual-number noise emission values in accordance with ISO 4871 with an associated uncertainty of +/-3dB(A). Measured in accordance with ISO 9614-1 and certified by Eurovent.
 (2) In dB ref 20μPa, 'A' weighted. Declared dual-number noise emission values in accordance with ISO 4871 with an associated uncertainty of +/-3dB(A). For information, calculated from the sound power Lw(A).
 (3) For information, calculated from the sound power Lw(A).



Eurovent certified values

TECHNICAL SPECIFICATIONS



POWERCAT LX ST-HE		0808	0908	1008	1108	1358	1528	1858	2008	2158
Compressors		06T semi-hermetic screw, 50 r/s								
Circuit A		1	1	1	1	1	1	1	1	1
Circuit B		1	1	1	1	1	1	1	1	1
Refrigerant⁽³⁾		R134a								
Circuit A	kg	37	35	35	51	52	54	58	58	65
	tCO _{2e}	52,9	50,1	50,1	72,2	74,4	76,5	82,9	82,9	93,0
Circuit B	kg	38,5	36	37	36,5	37	32,5	59	62	58
	tCO _{2e}	55,1	51,5	52,9	52,2	52,9	46,5	84,4	88,7	82,9
Oil										
Circuit A	l	20,8	20,8	20,8	23,5	23,5	23,5	23,5	23,5	27,6
Circuit B	l	20,8	20,8	20,8	20,8	20,8	20,8	23,5	23,5	23,5
Capacity control		Connect Touch, electronic expansion valve (EXV)								
Minimum capacity	%	15	15	15	15	15	15	15	15	15
Air-cooled exchanger		Aluminium micro-channel coils (MCHE)								
Fans										
LX ST-HE		Axial type, with rotating impeller								
Quantity		6	6	6	8	8	9	11	12	12
Maximum total air flow	l/s	27083	27083	27083	36111	36111	40624	49652	54166	54166
Maximum rotation speed	r/s	15,7	15,7	15,7	15,7	15,7	15,7	15,7	15,7	15,7
LX ST/HE Unit + Xtra Low Noise option										
Maximum total air flow	l/s	20500	20500	20500	27333	27333	30750	37583	41000	41000
Maximum rotation speed	r/s	11,7	11,7	11,7	11,7	11,7	11,7	11,7	11,7	11,7
Exchanger		Flooded multi-pipe type								
Water volume	l	58	61	61	66	70	77	79	94	98
Max. water-side operating pressure without hydraulic module	kPa	1000	1000	1000	1000	1000	1000	1000	1000	1000
Hydraulic module (option)		Pump, Victaulic screen filter, relief valve, water and air vent valve, pressure sensors								
Pump		Centrifugal pump, monocell, 48.3 r/s, low- or high-pressure (as required), single or dual (as required)								
Expansion vessel volume	l	50	50	50	50	50	80			
Max. water-side operating pressure with hydraulic module	kPa	400	400	400	400	400	400			
Water connections with or without hydraulic module		Victaulic® type								
Connections	inch	5 or 4	5 or 4	5 or 4	5 or 4	5 or 4	5 or 4	5	6	6
External diameter ⁽⁴⁾	mm	114,3 or 141,3	114,3 or 141,3	114,3 or 141,3	114,3 or 141,3	114,3 or 141,3	114,3 or 141,3	141,3	168,3	168,3
Casing paintwork		Colour code RAL 7035 & RAL 7024								

(3) Values are guidelines only. Refer to the unit name plate.

(4) Depends on the number of passes on the evaporator

TECHNICAL SPECIFICATIONS



POWERCIAT LX ST-HE			2308	2528	2628	3028	3428	3828	4008	4408	4608	
Cooling												
LX ST standard	Full load performances*	Nominal capacity	kW	785	841	886	976	1144	1247	1326	1433	1485
		EER	kW/kW	3,10	3,24	3,12	3,09	3,27	3,23	3,16	3,06	3,10
Seasonal energy efficiency	CA1	Eurovent class		A	A	A	B	A	A	A	B	A
		SEER _{12/7°C} Comfort low temp.	kWh/kWh	4,14	4,16	-	-	4,12	4,27	-	4,10	-
		η _{s cool} _{12/7°C}	%	162	163	-	-	162	168	-	161	-
		SEPR _{12/7°C} Process high temp.	kWh/kWh	5,10	5,39	5,17	5,09	5,42	5,49	5,40	5,46	5,13
		SEPR _{2/-8°C} Process medium temp.**	kWh/kWh	3,30	3,50	3,31	3,29	3,10	3,44	3,55	3,72	3,11
		IPLV.SI	kW/kW	4,475	4,554	4,321	4,254	4,450	4,590	4,320	4,450	4,260
LX ST with Xtra & Super Low Noise option	Full load performances*	Nominal capacity	kW	759	807	875	960	1107	1218	1285	1377	1404
		EER	kW/kW	2,88	2,98	2,91	2,95	2,97	3,01	2,81	2,69	2,85
Seasonal energy efficiency	CA1	Eurovent class		C	B	B	B	B	B	C	D	C
		SEER _{12/7°C} Comfort low temp.	kWh/kWh	-	4,10	-	-	-	4,12	-	-	4,09
		η _{s cool} _{12/7°C}	%	-	161	-	-	-	162	-	-	161
		SEPR _{12/7°C} Process high temp.	kWh/kWh	5,43	5,46	5,37	5,39	5,14	5,26	4,83	4,81	5,15
		SEPR _{2/-8°C} Process medium temp.**	kWh/kWh	3,63	3,64	3,58	3,60	3,48	3,44	3,74	3,82	3,30
		IPLV.SI	kW/kW	4,554	4,664	4,349	4,388	4,280	4,510	3,830	3,870	-
LX HE standard	Full load performances*	Nominal capacity	kW	779	833	878	971	1137	1237	1317	1423	1485
		EER	kW/kW	3,10	3,22	3,10	3,11	3,27	3,20	3,13	3,03	3,10
Seasonal energy efficiency	CA1	Eurovent class		A	A	A	A	A	A	A	B	A
		SEER _{12/7°C} Comfort low temp.	kWh/kWh	4,34	4,33	4,13	4,10	4,28	4,42	4,12	4,15	4,10
		η _{s cool} _{12/7°C}	%	171	170	162	161	168	174	162	163	161
		SEPR _{12/7°C} Process high temp.	kWh/kWh	5,57	5,83	5,57	5,55	5,77	5,74	5,62	5,55	5,38
		SEPR _{2/-8°C} Process medium temp.**	kWh/kWh	3,63	3,81	3,60	3,60	3,39	3,67	3,56	3,62	3,47
		IPLV.SI	kW/kW	4,554	4,664	4,349	4,388	4,280	4,510	3,830	3,870	-
LX HE with Xtra & Super Low Noise option	Full load performances*	Nominal capacity	kW	759	807	875	960	1107	1218	1285	1377	1404
		EER	kW/kW	2,90	3,00	2,93	2,97	3,03	3,07	2,88	2,75	2,85
Seasonal energy efficiency	CA1	Eurovent class		B	B	B	B	B	B	C	C	C
		SEER _{12/7°C} Comfort low temp.	kWh/kWh	4,10	4,14	4,10	4,10	4,14	4,41	-	-	4,13
		η _{s cool} _{12/7°C}	%	161	163	161	161	162	173	-	-	162
		SEPR _{12/7°C} Process high temp.	kWh/kWh	5,60	5,69	5,55	5,60	5,42	5,55	5,14	5,13	5,42
		SEPR _{2/-8°C} Process medium temp.**	kWh/kWh	3,71	3,75	3,67	3,69	3,66	3,65	3,87	3,82	3,82
		IPLV.SI	kW/kW	4,554	4,664	4,349	4,388	4,280	4,510	3,830	3,870	-
Sound levels												
LX ST-HE												
Sound power ⁽¹⁾												
Sound pressure at 10 m ⁽²⁾												
LX ST HE + Low Noise option												
Sound power ⁽¹⁾												
Sound pressure at 10 m ⁽²⁾												
LX ST-HE + Xtra low noise option												
Sound power ⁽¹⁾												
Sound pressure at 10 m ⁽²⁾												
LX ST-HE + Super low noise option												
Sound power ⁽¹⁾												
Sound pressure at 10 m ⁽²⁾												
Dimensions												
LX ST-HE												
Length	mm	7186	8380	8380	9574	11962	11962	11962	11962	11962	13157	
Width	mm	2253	2253	2253	2253	2253	2253	2253	2253	2253	2253	
Height	mm	2297	2297	2297	2297	2297	2297	2297	2297	2297	2297	
Operating weight⁽³⁾												
LX ST standard	kg	5687	6072	6376	6827	8070	8211	8790	8867	9181		
LX ST Unit + low noise option	kg	6018	6403	6707	7158	8441	8582	9162	9239	9553		
LX HE standard	kg	5687	6072	6376	6827	8070	8211	8790	8867	9181		
LX HE Unit + Low noise option	kg	6018	6403	6707	7158	8441	8582	9162	9239	9553		

* In accordance with standard EN14511-3:2013.
 ** With low-temperature brine solution option
 CA1 Cooling mode conditions: evaporator water inlet/outlet temperature 12 °C/7 °C, outdoor air temperature 35 °C, evaporator fouling factor 0 m²/kW
 η_{s cool} _{12/7°C} & SEER _{12/7°C} Applicable Ecodesign regulation (EU) No. 2016/2281
 SEPR _{12/7°C} Applicable Ecodesign regulation (EU) No. 2016/2281
 SEPR _{2/-8°C} Applicable Ecodesign regulation (EU) No. 2015/1095
 IPLV.SI Calculated as per AHRI standard 551-591.
 (1) In dB ref=10⁻¹² W, 'A' weighted. Declared dual-number noise emission values in accordance with ISO 4871 with an associated uncertainty of +/-3dB(A).
 Measured in accordance with ISO 9614-1 and certified by Eurovent.
 (2) In dB ref 20μPa, 'A' weighted. Declared dual-number noise emission values in accordance with ISO 4871 with an associated uncertainty of +/-3dB(A).
 For information, calculated from the sound power Lw(A).



Eurovent certified values

TECHNICAL SPECIFICATIONS



POWERCAT LX ST-HE		2308	2528	2628	3028	3428	3828	4008	4408	4608
Compressors		06T semi-hermetic screw, 50 r/s								
Circuit A		1	1	1	1	1	1	1	1	1
Circuit B		1	1	1	1	1	1	1	1	1
Refrigerant (3)		R134a								
Circuit A	kg	69	72	69	75	76	76	110	116	132
	tCO ₂ e	98,7	103,0	98,7	107,3	108,7	108,7	157,3	165,9	188,8
Circuit B	kg	65	63	76	79	108	120	116	124	120
	tCO ₂ e	93,0	90,1	108,7	113,0	154,4	171,6	165,9	177,3	171,6
Oil										
Circuit A	l	27,6	27,6	27,6	27,6	27,6	27,6	36,0	36,0	36,0
Circuit B	l	23,5	23,5	27,6	27,6	36,0	36,0	36,0	36,0	36,0
Capacity control		Connect Touch, electronic expansion valve (EXV)								
Minimum capacity	%	15	15	15	15	15	15	15	15	15
Air-cooled exchanger		Aluminium micro-channel coils (MCHE)								
Fans		Axial type, with rotating impeller								
LX ST-HE										
Quantity		12	14	14	16	20	20	20	20	22
Maximum total air flow	l/s	54166	63194	63194	72221	90277	90277	90277	90277	99304
Maximum rotation speed	r/s	15,7	15,7	15,7	15,7	15,7	15,7	15,7	15,7	15,7
LX ST/HE Unit + Xtra Low Noise option										
Maximum total air flow	l/s	41000	47833	47833	54667	68333	68333	68333	68333	75167
Maximum rotation speed	r/s	11,7	11,7	11,7	11,7	11,7	11,7	11,7	11,7	11,7
Exchanger		Flooded multi-pipe type								
Water volume	l	119	119	130	140	164	174	180	189	189
Max. water-side operating pressure without hydraulic module	kPa	1000	1000	1000	1000	1000	1000	1000	1000	1000
Water connections with or without hydraulic module		Victaulic® type								
Connections	inch	6	6	6	8	6	6	6	6	6
External diameter	mm	168,3	168,3	168,3	219,1	168,3	168,3	168,3	168,3	168,3
Casing paintwork		Colour code RAL 7035 & RAL 7024								

(3) Values are guidelines only. Refer to the unit name plate.

TECHNICAL SPECIFICATIONS



POWERCIAT LX XE			0808	0908	1008	1108	1358	1528	1858	2008	2158		
Cooling													
LX XE standard		Nominal capacity	kW		274	299	327	394	444	501	615	682	727
Full load performances*	CA1	EER	kW/kW		3,22	3,19	3,15	3,32	3,13	3,22	3,23	3,34	3,17
		Eurovent class			A	A	A	A	A	A	A	A	A
Seasonal energy efficiency		SEER_{12/7°C} Comfort low temp.	kWh/kWh		4,36	4,44	4,43	4,38	4,24	4,40	4,12	4,54	4,21
		η_{s cool}_{12/7°C}	%		171	174	174	172	167	173	162	179	165
		SEPR_{12/7°C} Process high temp.	kWh/kWh		6,06	6,22	6,34	5,93	5,88	6,05	5,81	6,30	5,68
		SEPR _{-2/-8°C} Process medium temp.**	kWh/kWh		3,59	3,80	3,90	3,61	3,76	3,85	3,82	4,11	3,68
LX XE with Xtra Low Noise option		Nominal capacity	kW		270	294	321	382	430	478	607	661	698
Full load performances*	CA1	EER	kW/kW		3,12	3,1	3,11	3,2	2,99	3,04	3,14	3,22	3,01
		Eurovent class			A	A	A	A	B	B	A	A	B
Seasonal energy efficiency		SEER_{12/7°C} Comfort low temp.	kWh/kWh		4,30	4,42	4,56	4,35	4,25	4,34	4,17	4,43	4,13
		η_{s cool}_{12/7°C}	%		169	174	179	171	167	170	164	174	162
		SEPR_{12/7°C} Process high temp.	kWh/kWh		5,93	6,15	6,45	5,88	5,81	5,88	5,97	6,19	5,65
		SEPR _{-2/-8°C} Process medium temp.**	kWh/kWh		3,54	3,82	4,01	3,65	3,72	3,77	3,92	4,08	3,71
Sound levels													
LX XE													
		Sound power ⁽¹⁾	dB(A)		99	99	99	99	101	99	101	99	103
		Sound pressure at 10 m ⁽²⁾	dB(A)		67	67	67	67	69	67	68	67	70
LX XE + low noise option													
		Sound power ⁽¹⁾	dB(A)		93	93	94	95	95	95	97	96	97
		Sound pressure at 10 m ⁽²⁾	dB(A)		61	61	62	63	63	63	65	63	64
LX XE + Xtra low noise option													
		Sound power ⁽¹⁾	dB(A)		87	87	87	90	91	91	93	92	94
		Sound pressure at 10 m ⁽²⁾	dB(A)		55	55	55	58	59	59	60	59	61

* In accordance with standard EN14511-3:2013.
 ** With low-temperature brine solution option
 CA1 Cooling mode conditions: evaporator water inlet/outlet temperature 12 °C/7 °C, outdoor air temperature 35 °C, evaporator fouling factor 0 m². kW
 η_{s cool}_{12/7°C} & SEER_{12/7°C} Applicable Ecodesign regulation (EU) No. 2016/2281
 SEPR_{12/7°C} Applicable Ecodesign regulation (EU) No. 2016/2281
 SEPR_{-2/-8°C} Applicable Ecodesign regulation (EU) No. 2015/1095
 IPLV.SI Calculated as per AHRI standard 551-591.
 (1) In dB ref=10⁻¹² W, 'A' weighted. Declared dual-number noise emission values in accordance with ISO 4871 with an associated uncertainty of +/-3dB(A). Measured in accordance with ISO 9614-1 and certified by Eurovent.
 (2) In dB ref 20μPa, 'A' weighted. Declared dual-number noise emission values in accordance with ISO 4871 with an associated uncertainty of +/-3dB(A). For information, calculated from the sound power L_w(A).



Eurovent certified values

TECHNICAL SPECIFICATIONS



POWERCAT LX XE		0808	0908	1008	1108	1358	1528	1858	2008	2158
Dimensions										
Standard unit										
Length	mm	3604	3604	3604	4798	4798	5992	7186	7186	7186
Width	mm	2253	2253	2253	2253	2253	2253	2253	2253	2253
Height	mm	2297	2297	2297	2297	2297	2297	2297	2297	2297
Operating weight⁽³⁾										
LX XE standard	kg	3190	3224	3245	3834	3899	4261	4962	5093	5376
LX XE + low noise option	kg	3458	3492	3513	4133	4198	4560	5293	5424	5707
Compressors		06T semi-hermetic screw, 50 r/s								
Circuit A		1	1	1	1	1	1	1	1	1
Circuit B		1	1	1	1	1	1	1	1	1
Refrigerant⁽³⁾		R134a								
Circuit A	kg	37	35	35	51	52	54	58	58	65
	tCO _{2e}	52,9	50,1	50,1	72,2	74,4	76,5	82,9	82,9	93,0
Circuit B	kg	38,5	36	37	36,5	37	32,5	59	62	58
	tCO _{2e}	55,1	51,5	52,9	52,2	52,9	46,5	84,4	88,7	82,9
Oil										
Circuit A	l	20,8	20,8	20,8	23,5	23,5	23,5	23,5	23,5	27,6
Circuit B	l	20,8	20,8	20,8	20,8	20,8	20,8	23,5	23,5	23,5
Capacity control		Connect Touch, electronic expansion valve (EXV)								
Minimum capacity	%	15	15	15	15	15	15	15	15	15
Air-cooled exchanger		Aluminium micro-channel coils (MCHE)								
Fans										
LX XE		Axial type, with rotating impeller								
Quantity		6	6	6	8	8	9	11	12	12
Maximum total air flow	l/s	28920	28920	28920	38560	38560	43380	53020	57840	57840
Maximum rotation speed	r/s	15,7	15,7	15,7	15,7	15,7	15,7	15,7	15,7	15,7
LX XE + Xtra low noise option										
Maximum total air flow	l/s	23580	23580	23580	31440	31440	35370	43230	47160	47160
Maximum rotation speed	r/s	11,7	11,7	11,7	11,7	11,7	11,7	11,7	11,7	11,7
Exchanger		Flooded multi-pipe type								
Water volume	l	58	61	61	66	70	77	79	94	98
Max. water-side operating pressure without hydraulic module	kPa	1000	1000	1000	1000	1000	1000	1000	1000	1000
Hydraulic module (option)		Pump, Victaulic screen filter, relief valve, water and air vent valve, pressure sensors								
Pump		Centrifugal pump, monocell, 48.3 r/s, low- or high-pressure (as required), single or dual (as required)								
Expansion vessel volume	l	50	50	50	50	50	80			
Max. water-side operating pressure with hydraulic module	kPa	400	400	400	400	400	400			
Water connections with or without hydraulic module		Victaulic® type								
Connections	inch	5 or 4	5 or 4	5 or 4	5 or 4	5 or 4	5 or 4	5	6	6
External diameter	mm	114,3 or 141,3	114,3 or 141,3	114,3 or 141,3	114,3 or 141,3	114,3 or 141,3	114,3 or 141,3	141,3	168,3	168,3
Casing paintwork		Colour code RAL 7035 & RAL 7024								

(3) Values are guidelines only. Refer to the unit name plate.

TECHNICAL SPECIFICATIONS



POWERCIAT LX XE			2308	2528	2628	3028	3428	3828	4008	4408	4608	
Cooling												
LX XE standard		Nominal capacity	kW	789	845	890	980	1150	1253	1333	1440	1493
Full load performances*	CA1	EER	kW/kW	3,19	3,32	3,19	3,2	3,36	3,3	3,22	3,12	3,19
		Eurovent class		A	A	A	A	A	A	A	A	A
Seasonal energy efficiency		Classe Eurovent	kWh/kWh	4,45	4,53	4,20	4,14	4,49	4,51	4,21	4,25	4,10
		SEER _{12/7°C} Comfort low temp.	%	175	178	165	162	177	177	165	167	161
		η _s cool _{12/7°C}	kWh/kWh	5,74	5,96	5,76	5,65	5,93	5,91	5,73	5,67	5,49
		SEPR _{12/7°C} Process high temp.	kWh/kWh	3,75	3,88	3,77	3,70	3,58	3,87	3,66	3,84	3,56
LX XE with Xtra Low Noise option		Nominal capacity	kW	767	814,8	884	976	1118	1230	1298	1391	1443
Full load performances*	CA1	EER	kW/kW	2,99	3,1	3,02	3,06	3,12	3,16	2,97	2,83	2,94
		Eurovent class		B	A	B	B	A	A	B	C	B
Seasonal energy efficiency		SEER _{12/7°C} Comfort low temp.	kWh/kWh	4,15	4,43	4,10	4,13	4,21	4,33	-	-	4,21
		η _s cool _{12/7°C}	%	163	174	161	162	165	170	-	-	165
		SEPR _{12/7°C} Process high temp.	kWh/kWh	5,75	5,85	5,68	5,72	5,57	5,68	5,34	5,30	5,48
		SEPR _{-2/-8°C} Process medium temp.**	kWh/kWh	3,80	3,82	3,76	3,78	3,76	3,76	3,90	3,85	3,88
Sound levels												
LX XE												
		Sound power ⁽¹⁾	dB(A)	103	101	104	102	103	102	104	104	104
		Sound pressure at 10 m ⁽²⁾	dB(A)	70	70	71	69	70	69	71	71	71
LX XE + low noise option												
		Sound power ⁽¹⁾	dB(A)	98	97	99	98	98	98	100	99	99
		Sound pressure at 10 m ⁽²⁾	dB(A)	65	65	66	65	65	65	67	65	65
LX XE + Xtra low noise option												
		Sound power ⁽¹⁾	dB(A)	94	94	95	94	94	94	99	95	96
		Sound pressure at 10 m ⁽²⁾	dB(A)	61	61	62	61	61	61	66	62	63

* In accordance with standard EN14511-3:2013.

** With low-temperature brine solution option

CA1 Cooling mode conditions: evaporator water inlet/outlet temperature 12 °C/7 °C, outdoor air temperature 35 °C, evaporator fouling factor 0 m². kW

η_s cool_{12/7°C} & SEER_{12/7°C} Applicable Ecodesign regulation (EU) No. 2016/2281

SEPR_{12/7°C} Applicable Ecodesign regulation (EU) No. 2016/2281

SEPR_{-2/-8°C} Applicable Ecodesign regulation (EU) No. 2015/1095

IPLV.SI Calculated as per AHRI standard 551-591.

(1) In dB ref=10⁻¹² W, 'A' weighted. Declared dual-number noise emission values in accordance with ISO 4871 with an associated uncertainty of +/-3dB(A). Measured in accordance with ISO 9614-1 and certified by Eurovent.

(2) In dB ref 20μPa, 'A' weighted. Declared dual-number noise emission values in accordance with ISO 4871 with an associated uncertainty of +/-3dB(A). For information, calculated from the sound power Lw(A).



Eurovent certified values

TECHNICAL SPECIFICATIONS



POWERCAT LX XE		2308	2528	2628	3028	3428	3828	4008	4408	4608
Dimensions										
Standard unit										
Length	mm	7186	8380	8380	9574	11962	11962	11962	11962	13157
Width	mm	2253	2253	2253	2253	2253	2253	2253	2253	2253
Height	mm	2297	2297	2297	2297	2297	2297	2297	2297	2297
Operating weight⁽³⁾										
LX XE standard	kg	5687	6072	6376	6827	8070	8211	8790	8867	9181
LX XE + low noise option	kg	6018	6403	6707	7158	8441	8582	9162	9239	9553
Compressors		06T semi-hermetic screw, 50 r/s								
Circuit A		1	1	1	1	1	1	1	1	1
Circuit B		1	1	1	1	1	1	1	1	1
Refrigerant⁽³⁾		R134a								
Circuit A	kg	69	72	69	75	76	76	110	116	132
	tCO _{2e}	98,7	103,0	98,7	107,3	108,7	108,7	157,3	165,9	188,8
Circuit B	kg	65	63	76	79	108	120	116	124	120
	tCO _{2e}	93,0	90,1	108,7	113,0	154,4	171,6	165,9	177,3	171,6
Oil										
Circuit A	l	27,6	27,6	27,6	27,6	27,6	27,6	36,0	36,0	36,0
Circuit B	l	23,5	23,5	27,6	27,6	36,0	36,0	36,0	36,0	36,0
Capacity control		Connect Touch, electronic expansion valve (EXV)								
Minimum capacity	%	15	15	15	15	15	15	15	15	15
Air-cooled exchanger		Aluminium micro-channel coils (MCHE)								
Fans		Axial type, with rotating impeller								
LX XE										
Quantity		12	14	14	16	20	20	20	20	22
Maximum total air flow	l/s	57840	67480	67480	77120	96400	96400	96400	96400	106040
Maximum rotation speed	r/s	15,7	15,7	15,7	15,7	15,7	15,7	15,7	15,7	15,7
LX XE + Xtra low noise option										
Maximum total air flow	l/s	47160	55020	55020	62880	78600	78600	78600	78600	86460
Maximum rotation speed	r/s	11,7	11,7	11,7	11,7	11,7	11,7	11,7	11,7	11,7
Exchanger		Flooded multi-pipe type								
Water volume	l	119	119	130	140	164	174	180	189	189
Max. water-side operating pressure without hydraulic module	kPa	1000	1000	1000	1000	1000	1000	1000	1000	1000
Water connections with or without hydraulic module		Victaulic® type								
Connections	inch	6	6	6	8	6	6	6	6	6
External diameter	mm	168,3	168,3	168,3	219,1	168,3	168,3	168,3	168,3	168,3
Casing paintwork		Colour code RAL 7035 & RAL 7024								

(3) Values are guidelines only. Refer to the unit name plate.

ELECTRICAL SPECIFICATIONS

Basic unit (excluding pump)

POWERCIAT LX ST/HE		0808	0908	1008	1108	1358	1528	1858	2008	2158	2308	2528	2628	3028
Power circuit supply														
Nominal voltage	V-ph-Hz	400-3-50												
Voltage range	V	360-440												
Control circuit supply														
24 V via internal transformer														
Maximum operating input power⁽¹⁾ - LX ST/HE														
Standard unit	kW	121	135	148	170	197	216	266	288	322	340	369	397	459
Unit + Xtra / Super Low Noise option	kW	115	128	141	161	188	206	253	274	308	326	354	383	443
Power factor at maximum power⁽²⁾ - LX ST/HE														
Displacement Power Factor (Cos Phi)		0,88	0,88	0,88	0,88	0,89	0,89	0,89	0,89	0,89	0,89	0,89	0,90	0,90
Displacement Power Factor (Cos Phi) unit + Xtra / Super Low noise option		0,88	0,88	0,88	0,88	0,89	0,89	0,89	0,89	0,89	0,89	0,89	0,90	0,90
Nominal unit current draw⁽³⁾ - LX ST/HE														
Standard unit	A	154	170	186	215	246	267	332	358	409	430	446	502	542
Unit + Xtra / Super Low Noise option	A	143	159	175	200	231	252	311	335	386	407	423	479	515
Maximum operating current draw (Un)⁽¹⁾ - LX ST/HE														
Standard unit	A	198	220	242	278	319	349	431	466	521	551	597	636	736
Unit + Xtra / Super Low Noise option	A	187	209	231	263	304	334	410	443	498	528	574	613	709
Maximum current (Un-10 %)⁽²⁾ - LX ST/HE														
Standard unit	A	198	220	242	278	319	349	431	466	521	551	597	636	736
Unit + Xtra / Super Low Noise option	A	187	209	231	263	304	334	410	443	498	528	574	613	709
Start-up current⁽³⁾ + ⁽⁴⁾ - LX ST/HE														
Standard unit	A	213	224	224	346	442	442	492	492	676	691	691	733	756
Unit + Xtra / Super Low Noise option	A	210	221	221	343	439	439	487	486	671	686	686	727	750
Maximum start-up current (Un)⁽²⁾ + ⁽⁴⁾ - LX ST/HE														
Standard unit	A	213	224	224	346	442	442	492	492	676	691	691	733	756
Unit + Xtra / Super Low Noise option	A	210	221	221	343	439	439	487	486	671	686	686	727	750

- (1) Values at the unit's permanent maximum operating condition (as shown on the unit's nameplate).
- (2) Values at the unit's maximum operating condition (as shown on the unit's nameplate).
- (3) Maximum operating current of the smallest compressor(s) + fan current + locked rotor current of the largest compressor.
- (4) Standardised EUROVENT conditions, water-cooled exchanger inlet/outlet = 12°C/7°C, outdoor air temperature = 35°C.
- (a) When the machines are equipped with two power supplies, circuit 1 is intended to supply refrigerant circuit A and circuit 2 supplies refrigerant circuit B.
For units LX 3428 to 4608: circuit 1 supplies circuit A, circuit 2 supplies circuit B.

ELECTRICAL SPECIFICATIONS

POWERCAT LX ST/HE		3428	3828	4008	4408	4608
Power circuit supply						
Nominal voltage	V-ph-Hz	400-3-50				
Voltage range	V	360-440				
Control circuit supply		24 V via internal transformer				
Maximum operating input power⁽¹⁾ - LX ST/HE						
Standard unit	kW					
Circuit 1 ^(a)	kW	198	226	269	288	311
Circuit 2 ^(a)	kW	288	314	287	309	311
Single power connection point option	kW	485	539	556	596	622
Unit with Xtra & Super Low Noise option						
Circuit 1 ^(a)	kW	190	218	258	276	298
Circuit 2 ^(a)	kW	277	301	276	297	298
Single power connection point option	kW	466	519	533	573	597
Power factor at maximum power⁽¹⁾ - LX ST/HE						
Standard unit						
Displacement Power Factor (Cos Phi)		0,88	0,88	0,88	0,88	0,88
Unit + Xtra & Super low noise option						
Displacement Power Factor (Cos Phi)		0,88	0,88	0,88	0,88	0,88
Nominal unit current draw⁽²⁾ - LX ST/HE						
Standard unit						
Circuit 1 ^(a)	A	255	271	345	358	394
Circuit 2 ^(a)	A	354	394	358	390	394
Single power connection point option	A	609	665	703	748	789
Unit + Xtra & Super low noise option						
Circuit 1 ^(a)	A	242	258	326	339	373
Circuit 2 ^(a)	A	337	373	339	371	373
Single power connection point option	A	579	631	665	710	747
Maximum operating current draw (Un)⁽¹⁾ - LX ST/HE						
Standard unit						
Circuit 1 ^(a)	A	322	368	443	473	512
Circuit 2 ^(a)	A	469	512	473	508	512
Single power connection point option	A	791	880	916	981	1025
Unit with Xtra & Super Low Noise option						
Circuit 1 ^(a)	A	309	355	424	454	491
Circuit 2 ^(a)	A	452	491	454	489	491
Single power connection point option	A	761	846	878	943	983
Maximum current (Un-10 %)⁽¹⁾ - LX ST/HE						
Standard unit						
Circuit 1 ^(a)	A	322	368	443	473	512
Circuit 2 ^(a)	A	469	512	473	508	512
Single power connection point option	A	791	880	916	981	1025
Unit with Xtra & Super Low Noise option						
Circuit 1 ^(a)	A	309	355	424	454	491
Circuit 2 ^(a)	A	452	491	454	489	491
Single power connection point option	A	761	846	878	943	983

(1) Values at the unit's permanent maximum operating condition (as shown on the unit's nameplate).

(2) Values at the unit's maximum operating condition (as shown on the unit's nameplate).

(a) When the machines are equipped with two power supplies, circuit 1 is intended to supply refrigerant circuit A and circuit 2 supplies refrigerant circuit B.
For units LX 3428 to 4608: circuit 1 supplies circuit A, circuit 2 supplies circuit B.

ELECTRICAL SPECIFICATIONS

POWERCIAT LX ST/HE		3428	3828	4008	4408	4608
Start-up current⁽³⁾ - LX ST/HE						
Standard unit						
Circuit 1 ^(a)	A	587	587	629	629	629
Circuit 2 ^(a)	A	629	629	629	629	629
Single power connection point option	A	687	702	729	744	744
Unit + Xtra & Super low noise option						
Circuit 1 ^(a)	A	587	587	629	629	629
Circuit 2 ^(a)	A	629	629	629	629	629
Single power connection point option	A	687	702	729	744	744
Maximum start-up current (Un)⁽²⁾ - LX ST/HE						
Standard unit						
Circuit 1 ^(a)	A	587	587	629	629	629
Circuit 2 ^(a)	A	629	629	629	629	629
Single power connection point option	A	687	702	729	744	744
Unit + Xtra & Super low noise option						
Circuit 1 ^(a)	A	576	576	613	613	611
Circuit 2 ^(a)	A	615	611	613	613	611
Single power connection point option	A	687	702	729	744	744

(2) Values at the unit's maximum operating condition (as shown on the unit's nameplate).

(3) Maximum operating current of the smallest compressor(s) + fan current + locked rotor current of the largest compressor.

(a) When the machines are equipped with two power supplies, circuit 1 is intended to supply refrigerant circuit A and circuit 2 supplies refrigerant circuit B.
For units LX 3428 to 4608: circuit 1 supplies circuit A, circuit 2 supplies circuit B.

ELECTRICAL SPECIFICATIONS

POWERCAT LX XE		0808	0908	1008	1108	1358	1528	1858	2008	2158	2308	2528	2628	3028
Power circuit supply														
Nominal voltage	V-ph-Hz	400-3-50												
Voltage range	V	360-440												
Control circuit supply		24 V via internal transformer												
Maximum operating input power⁽¹⁾														
Standard unit	kW	125	136	147	170	192	211	258	278	313	332	361	385	446
Unit + Xtra / Super Low Noise option	kW	121	132	144	166	187	206	251	271	305	324	352	377	437
Power factor at maximum power⁽²⁾														
Displacement Power Factor (Cos Phi)+		0,88	0,88	0,88	0,88	0,89	0,89	0,89	0,89	0,89	0,89	0,89	0,90	0,90
Displacement Power Factor (Cos Phi) unit + Xtra / Super Low noise option		0,88	0,88	0,88	0,88	0,89	0,89	0,89	0,89	0,89	0,89	0,89	0,90	0,90
Nominal operating current draw⁽³⁾														
Circuit 1 ^(a)	A	146	162	178	205	236	257	318	342	393	414	430	486	524
Unit + Xtra / Super Low Noise option	A	140	156	172	197	228	248	307	330	381	402	416	472	510
Maximum operating current draw (Un)⁽¹⁾														
Circuit 1 ^(a)	A	204	222	240	279	312	342	417	450	505	535	581	620	718
Unit + Xtra / Super Low Noise option	A	198	216	234	271	304	333	406	438	493	523	567	606	704
Maximum current (Un-10 %)⁽²⁾														
Circuit 1 ^(a)	A	204	222	240	279	312	342	417	450	505	535	581	620	718
Unit + Xtra / Super Low Noise option	A	198	216	234	271	304	333	406	438	493	523	567	606	704
Start-up current^{(3) + (4)}														
Circuit 1 ^(a)	A	207	218	218	338	434	434	481	480	664	679	679	721	742
Unit + Xtra / Super Low Noise option	A	204	215	215	335	431	431	476	474	659	674	674	715	736
Maximum start-up current (Un)^{(2) + (3)}														
Circuit 1 ^(a)	A	207	218	218	338	434	434	481	480	664	679	679	721	742
Unit + Xtra / Super Low Noise option	A	204	215	215	335	431	431	476	474	659	674	674	715	736

- (1) Values at the unit's permanent maximum operating condition (as shown on the unit's nameplate).
 (2) Values at the unit's maximum operating condition (as shown on the unit's nameplate).
 (3) Maximum operating current of the smallest compressor(s) + fan current + locked rotor current of the largest compressor.
 (4) Standardised EUROVENT conditions, water-cooled exchanger inlet/outlet = 12°C/7°C, outdoor air temperature = 35°C.
 (a) When the machines are equipped with two power supplies, circuit 1 is intended to supply refrigerant circuit A and circuit 2 supplies refrigerant circuit B.
 For units LX 3428 to 4608: circuit 1 supplies circuit A, circuit 2 supplies circuit B.

ELECTRICAL SPECIFICATIONS

POWERCIAT LX XE		3428	3828	4008	4408	4608
Power circuit supply						
Nominal voltage	V-ph-Hz	400-3-50				
Voltage range	V	360-440				
Control circuit supply						
24 V via internal transformer						
Maximum operating input power⁽¹⁾ or ⁽²⁾						
Standard unit						
Circuit 1 ^(a)	kW	189	217	260	278	301
Circuit 2 ^(a)	kW	276	300	278	299	300
Single power connection point option	kW	465	517	537	576	601
Unit + Xtra & Super low noise option						
Circuit 1 ^(a)	kW	184	212	253	271	294
Circuit 2 ^(a)	kW	271	294	272	293	294
Single power connection point option	kW	453	505	525	564	588
Power factor at maximum power⁽¹⁾ or ⁽²⁾						
Standard unit						
Displacement Power Factor (Cos Phi)		0,87	0,87	0,87	0,87	0,87
Unit + Xtra & Super low noise option						
Displacement Power Factor (Cos Phi) unit + Xtra & Super Low noise option		0,86	0,87	0,87	0,86	0,86
Nominal operating current draw⁽³⁾						
Standard unit						
Circuit 1 ^(a)	A	246	262	332	345	380
Circuit 2 ^(a)	A	342	380	345	377	380
Single power connection point option	A	588	642	677	722	760
Unit + Xtra & Super low noise option						
Circuit 1 ^(a)	A	239	255	322	335	369
Circuit 2 ^(a)	A	333	369	335	367	369
Single power connection point option	A	569	622	657	702	738
Maximum operating current draw (Un)⁽¹⁾ or ⁽²⁾						
Standard unit						
Circuit 1 ^(a)	A	313	359	430	460	498
Circuit 2 ^(a)	A	457	498	460	495	498
Single power connection point option	A	770	857	890	955	996
Unit + Xtra & Super low noise option						
Circuit 1 ^(a)	A	306	352	420	450	487
Circuit 2 ^(a)	A	448	487	450	485	487
Single power connection point option	A	751	837	870	935	974
Maximum current (Un-10 %)⁽¹⁾ or ⁽²⁾						
Standard unit						
Circuit 1 ^(a)	A	313	359	430	460	498
Circuit 2 ^(a)	A	457	498	460	495	498
Single power connection point option	A	770	857	890	955	996
Unit + Xtra & Super low noise option						
Circuit 1 ^(a)	A	306	352	420	450	487
Circuit 2 ^(a)	A	448	487	450	485	487
Single power connection point option	A	751	837	870	935	974

(1) Values at the unit's permanent maximum operating condition (as shown on the unit's nameplate).

(2) Values at the unit's maximum operating condition (as shown on the unit's nameplate).

(3) Maximum operating current of the smallest compressor(s) + fan current + locked rotor current of the largest compressor.

(a) When the machines are equipped with two power supplies, circuit 1 is intended to supply refrigerant circuit A and circuit 2 supplies the refrigerant circuit B

ELECTRICAL SPECIFICATIONS

POWERCAT LX XE		3428	3828	4008	4408	4608
Start-up current^{(3) + (4)}						
Standard unit						
Circuit 1 ^(a)	A	587	587	629	629	629
Circuit 2 ^(a)	A	629	629	629	629	629
Single power connection point option	A	687	702	729	744	744
Unit + Xtra & Super low noise option						
Circuit 1 ^(a)	A	587	587	629	629	629
Circuit 2 ^(a)	A	629	629	629	629	629
Single power connection point option	A	670	681	710	725	723
Maximum start-up current (Un)^{(2) + (4)}						
Standard unit						
Circuit 1 ^(a)	A	587	587	629	629	629
Circuit 2 ^(a)	A	629	629	629	629	629
Single power connection point option	A	687	702	729	744	744
Unit + Xtra & Super low noise option						
Circuit 1 ^(a)	A	587	587	629	629	629
Circuit 2 ^(a)	A	629	629	629	629	629
Single power connection point option	A	670	681	710	725	723

- (2) Values at the unit's maximum operating condition (as shown on the unit's nameplate).
 (3) Maximum operating current of the smallest compressor(s) + fan current + locked rotor current of the largest compressor.
 (4) Standardised EUROVENT conditions, water-cooled exchanger inlet/outlet = 12°C/7°C, outdoor air temperature = 35°C.
 (a) When the machines are equipped with two power supplies, circuit 1 is intended to supply refrigerant circuit A and circuit 2 supplies the refrigerant circuit B

Short circuit current withstand capability (TN system⁽¹⁾)

POWERCAT LX ST/HE/XE		0808 to 1528	1858 to 3028	3428 to 4608
Short-circuit withstand current (TN system)				
Circuit A+B	kA	38	50	50
Circuit C+D	kA	NA	NA	50
Unit + single power connection point option	A	NA	NA	50

- (1) If another current limitation protection device is used, its time-current and thermal constraint (I²t) trip characteristics must be at least equivalent to those of the recommended protection.

Note: The short-circuit stability current values above are suitable with the TN system.

TOTAL HEAT RECOVERY



The POWERCIAT range can be equipped with a total heat recovery function as an option

Free, additional hot water is produced at a temperature of up to 60 °C by adding a water-cooled condenser to each refrigerant circuit (sizes 1858 to 3028) or by adding a double-circuit condenser (sizes 808 to 1528) to recover all the heat released by the unit.

This optional configuration requires assembly in our factories and is by order only.

This option is available for models 808 to 3028.

■ Operating principle

If hot water production is required, the compressor discharge gases are directed towards the heat recovery condenser. The refrigerant releases its heat to the hot water that leaves the condenser at a temperature of up to 60 °C. In this way 100% of the heat rejected by the liquid chiller can be used to produce hot water. When the demand for heat is satisfied, the hot gas is again directed towards the air condenser where the heat is rejected to the outside air by the fans.

Hot water temperature control is ensured by the machine's Connect Touch control that independently controls the recovery operation of each refrigerant circuit.

Note: Heat recovery is only possible if the machine produces cold water at the same time.

In part load operation, the limitation of the condenser water outlet temperature is due to the operating range of the screw compressor. If the condenser water outlet temperature is above the limit value given in the curves below, the unit will automatically change over to the mode without heat recovery

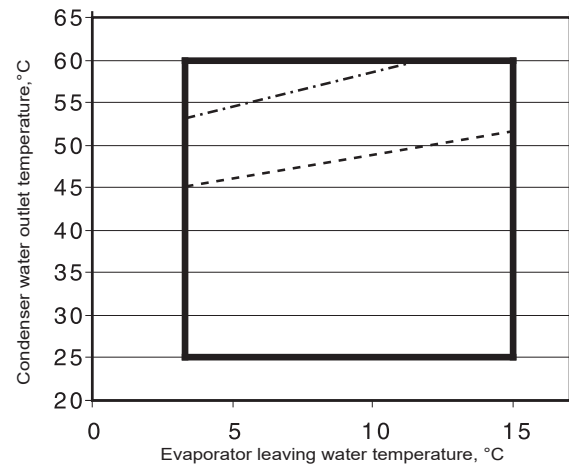

- Full load
- - - Part load limit, approx. 60%
- · · Minimum load limit, approx. 30%

Part load operating limits (evaporator leaving water temperature = 7°C)

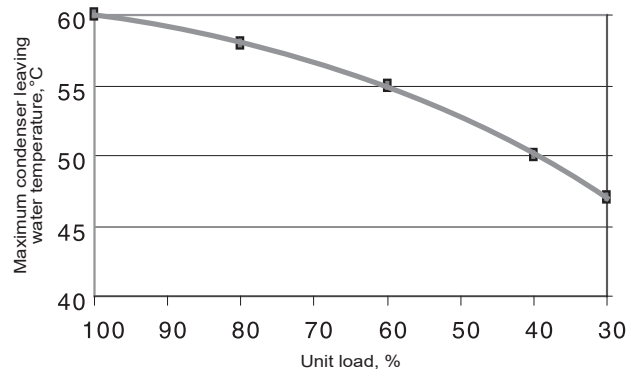

■ Operating limits

Condenser water temperature (°C)		Minimum	Maximum
Inlet temperature at start-up	°C	12.5 ⁽¹⁾	55
Inlet temperature during operation	°C	20	55
Outlet temperature during operation	°C	25	60
Evaporator water temperature (°C)		Minimum	Maximum
Inlet temperature at start-up	°C	-	45
Inlet temperature during operation	°C	6,8	21

(1) The water inlet temperature at start-up must not fall below 12.5 °C. For installations with a lower temperature a three-way valve must be used.
Note: If the evaporator water outlet temperature is below 4 °C, a brine solution or the frost protection option must be used.

TOTAL HEAT RECOVERY



■ Technical characteristics

POWERCAT LX ST/HE/XE heat recovery mode		0808	0908	1008	1108	1358	1528	1858	2008	2158	2308	2528	2628	3028
Operating weight ⁽¹⁾	kg	3370	3404	3425	4102	4245	4601	5551	5782	6065	6382	6430	6805	7272
Condenser diameter	in	10	10	10	12	14	14	12+12	12+12	14+12	14+12	14+12	14+14	14+14
Refrigerant charge														
Circuit A	kg	37	35	35	51	52	59	58	58	65	69	72	69	91
Circuit B	kg	39	37	37	37	37	36	59	62	58	65	63	76	89
Heat recovery condenser		Shell and tube condenser												
Water volume	l	38	38	38	55	68	68	55+55	55+55	68 + 55	68 + 55	68 + 55	68+68	68+68
Water connections		Type Victaulic												
Nominal diameter	inch	3	3	3	4	4	4	4	4	4	4	4	4	4
Actual outside diameter	mm	88,9	88,9	88,9	114,3	114,3	114,3	114,3	114,3	114,3	114,3	114,3	114,3	114,3

(1) Weights are for guidance only

OPERATING PRESSURE VENTILATION

The POWERCAT range can be equipped as an option with operating pressure ventilation.

■ Functions

This option allows a duct connection at the discharge side of the condenser fan. The unit is equipped with axial flow fans with connection flange. The water chiller can operate with an available static pressure of up to 60 Pa with reduced performance. The performance can be estimated using the coefficients below, which apply within the application limit conditions (see chart showing application limits for correction factors)

Operating pressure fan		Correction factors			
Operating pressure	Pa	0	20	40	60
Air flow rate	%	0	-3.5%	-7.5%	-12.1%
Cooling capacity	%	0	-0.5%	-1.0%	-1.5%
EER	%	0	-1.5%	-3.5%	-5.0%
Power input	%	0	+1.0%	+2.5%	+3.5%

■ Precautions for installation

If an air discharge duct is installed on site, its weight must not be supported by the roof of the unit. Each fan must be connected independently.

The duct must be connected to the unit using a supply air connection flange, included in the option

Application limit for correction factors for high air temperatures

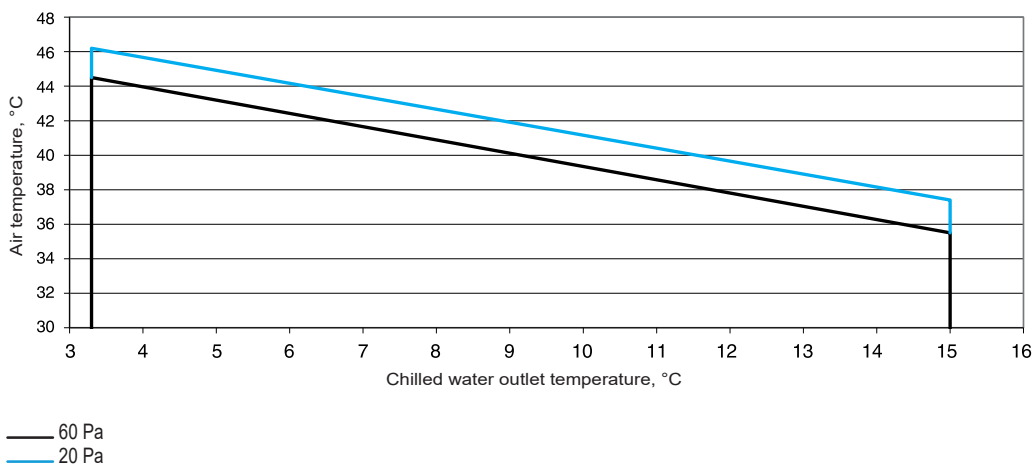

INTELLIGENTLY DESIGNED ACOUSTICS

To comply with the various integration restrictions, the POWERCIAT has three sound finish levels enabling it to be easily integrated into a number of zones without causing disruption to users or their neighbours.

■ Basic version

The distinguishing feature of the POWERCIAT range is its rigorous design incorporating "noiseless" assembly techniques to reduce vibrations and sources of noise:

- Low-pulse screw compressors with silencer integrated into the oil separator
- Silencer on the economiser return line
- Condenser coils with a V-shaped design featuring an open angle, for quieter air flow across the coil
- Quiet latest generation fans that produce no intrusive noise at low frequencies
- EC fans (XE version) that allow the machine's air flow to be adjusted as necessary and reduce the sound level at part load
- The Connect Touch controller automatically adjusts the fan air flow rate according to the outdoor air temperature and the unit's load rate which enables the sound level to be significantly reduced, particularly at night, mid-season, morning and evening, which totals more than 75% of the time the unit is used.

■ Low Noise option

In this version, in addition to the basic equipment, the compressors are placed in soundproof boxes equipped with absorbent materials limiting the level of noise radiated by the machine.

■ Xtra Low Noise option

In this version, the compressors are housed in sound boxes identical to those in the Low Noise version and the fan rotation speed is reduced whilst ensuring the output and thermal performance remain optimised.

■ Super Low Noise option

In this version, available for sizes 1358 to 4608, the compressors are housed in soundproof boxes identical to those in the Xtra Low Noise version, and the fan rotation speed is reduced by means of improved sound insulation that targets the machine's main sources of noise

■ Night mode

The POWERCIAT has a Night Mode enabling the sound level to be limited at night or when the building is unoccupied (according to the user programming) by controlling the output and the fan rotation speed.

■ Acoustic signature

As important as the sound power level, the acoustic signature reflects the noise disturbance generated by the unit.

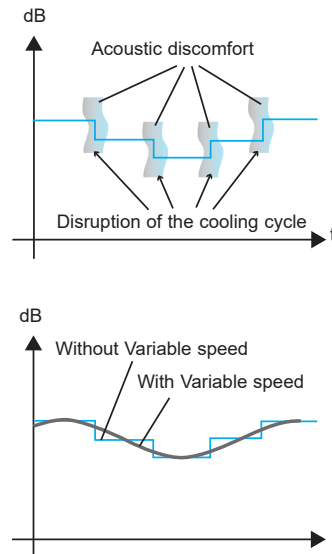

The POWERCIAT XE series has EC-type variable-speed motors on the fan motor assemblies as standard.

POWERCIAT ST series units equipped as an option with variable speed motors (all-season operation) have one variable speed AC fan motor per refrigerant circuit.

In addition to electrical performance, the EC motor also enables soft start for the fans. It avoids the increases in noise linked to the on/off sequences, thereby improving the unit's acoustic signature.

With all these benefits and its four acoustic finish levels (Standard, Low Noise, Xtra Low Noise and Super Low Noise), the POWERCIAT can be integrated into any site, ensuring any constraints in terms of the sound environment can be met.

SOUND LEVELS

ST-HE versions

■ Sound power levels ref $10^{-12} \text{ W} \pm 3 \text{ dB (Lw)}$

At nominal EN 14511-3: 2013 operating conditions in cooling mode

POWERCAT LX ST-HE	SOUND POWER LEVEL SPECTRUM (dB)						Overall power level dB(A)
	125 Hz	250 Hz	500 Hz	1000 Hz	2000 Hz	4000 Hz	
0808	96	95	92	99	87	82	100
0908	96	95	92	99	87	82	100
1008	96	95	93	99	87	83	100
1108	97	95	94	98	89	85	100
1358	104	107	95	97	89	85	102
1528	97	94	96	97	92	87	100
1858	103	107	97	96	92	87	102
2008	97	94	96	97	93	87	100
2158	104	107	97	99	91	87	103
2308	99	101	98	101	93	88	103
2528	99	98	97	98	92	89	101
2628	99	103	98	102	92	88	104
3028	101	102	99	100	92	92	103
3428	101	104	101	100	95	90	104
3828	101	104	100	99	95	90	103
4008	101	103	103	102	94	89	105
4408	100	103	103	102	94	89	105
4608	101	103	103	102	94	89	105

■ Sound pressure levels ref $2 \times 10^{-5} \text{ Pa} \pm 3 \text{ dB (Lp)}$

Measurement conditions: free field, 10 metres from machine, 1.50 metres above floor level, directivity 2

POWERCAT LX ST-HE	SOUND PRESSURE SPECTRUM (dB)						Overall pressure level dB(A)
	125 Hz	250 Hz	500 Hz	1000 Hz	2000 Hz	4000 Hz	
0808	64	63	60	67	55	50	68
0908	64	63	60	67	55	50	68
1008	64	63	61	67	55	51	68
1108	65	63	62	66	57	53	68
1358	72	75	63	65	57	53	70
1528	65	62	64	65	60	55	68
1858	70	74	64	63	59	54	69
2008	64	61	63	64	60	54	67
2158	71	74	64	66	58	54	70
2308	66	68	65	68	60	55	70
2528	66	65	64	65	59	56	68
2628	66	70	65	69	59	55	71
3028	68	69	66	67	59	59	70
3428	68	71	68	67	62	57	71
3828	68	71	67	66	62	57	70
4008	68	70	70	69	61	56	72
4408	67	70	70	69	61	56	72
4608	68	70	70	69	61	56	72

SOUND LEVELS

ST-HE versions with LOW NOISE option

■ Sound power levels ref $10^{-12} \text{ W} \pm 3 \text{ dB (Lw)}$

At nominal EN 14511-3: 2013 operating conditions in cooling mode

POWERCIAT LX ST-HE	SOUND POWER LEVEL SPECTRUM (dB)						Overall power level dB(A)
	125 Hz	250 Hz	500 Hz	1000 Hz	2000 Hz	4000 Hz	
0808	95	93	90	91	84	81	94
0908	95	93	90	91	84	81	94
1008	96	94	92	92	85	82	95
1108	96	95	93	92	87	83	96
1358	96	93	93	92	88	83	96
1528	96	93	94	92	87	83	96
1858	97	96	95	94	90	85	98
2008	97	93	94	92	87	84	96
2158	101	99	94	94	87	84	98
2308	98	95	95	95	88	84	98
2528	99	95	96	94	89	85	98
2628	98	96	95	96	88	84	99
3028	99	94	95	94	88	85	98
3428	101	97	95	92	91	88	98
3828	101	97	95	92	91	88	98
4008	101	99	99	96	92	90	101
4408	101	99	97	93	91	88	99
4608	101	98	96	93	91	88	99

■ Sound pressure levels ref $2 \times 10^{-5} \text{ Pa} \pm 3 \text{ dB (Lp)}$

Measurement conditions: free field, 10 metres from machine, 1.50 metres above floor level, directivity 2

POWERCIAT LX ST-HE	SOUND PRESSURE SPECTRUM (dB)						Overall pressure level dB(A)
	125 Hz	250 Hz	500 Hz	1000 Hz	2000 Hz	4000 Hz	
0808	62	61	58	58	52	49	62
0908	62	61	58	58	52	49	62
1008	64	62	59	59	53	49	63
1108	64	62	61	60	55	50	64
1358	64	61	60	60	56	51	64
1528	64	61	61	59	55	51	64
1858	64	64	62	61	57	52	65
2008	64	60	61	59	55	51	63
2158	68	66	62	62	54	51	65
2308	65	63	62	62	55	51	65
2528	66	62	63	61	56	52	65
2628	66	63	63	64	55	52	66
3028	66	61	63	62	55	53	65
3428	67	64	62	59	57	55	65
3828	67	64	62	59	57	55	65
4008	68	66	66	63	59	56	68
4408	67	65	63	60	58	55	66
4608	68	65	63	60	58	55	66

SOUND LEVELS

ST-HE versions with XTRA LOW NOISE option

■ Sound power levels ref $10^{-12} \text{ W} \pm 3 \text{ dB (Lw)}$

At nominal EN 14511-3: 2013 operating conditions in cooling mode

POWERCAT LX ST-HE	SOUND POWER LEVEL SPECTRUM (dB)						Overall power level dB(A)
	125 Hz	250 Hz	500 Hz	1000 Hz	2000 Hz	4000 Hz	
0808	86	89	83	83	77	68	87
0908	86	89	83	83	77	68	87
1008	86	89	83	83	77	68	87
1108	87	92	87	86	80	70	90
1358	87	96	87	85	80	69	91
1528	90	93	88	86	81	71	91
1858	88	96	91	88	82	76	93
2008	90	94	90	87	83	72	92
2158	88	96	91	89	81	70	93
2308	90	94	92	90	82	72	94
2528	94	95	92	88	82	74	93
2628	91	94	94	92	81	72	95
3028	96	96	93	89	81	75	94
3428	96	94	91	87	86	85	94
3828	96	94	91	87	86	85	94
4008	96	97	99	92	90	87	99
4408	96	94	91	89	88	86	95
4608	97	95	92	90	89	86	96

■ Sound pressure levels ref $2 \times 10^{-5} \text{ Pa} \pm 3 \text{ dB (Lp)}$

Measurement conditions: free field, 10 metres from machine, 1.50 metres above floor level, directivity 2

POWERCAT LX ST-HE	SOUND PRESSURE SPECTRUM (dB)						Overall pressure level dB(A)
	125 Hz	250 Hz	500 Hz	1000 Hz	2000 Hz	4000 Hz	
0808	54	57	51	51	45	36	55
0908	54	57	51	51	45	36	55
1008	54	57	51	51	45	36	55
1108	55	60	55	53	48	38	58
1358	55	64	55	53	48	37	59
1528	58	61	56	54	49	39	59
1858	55	63	58	55	49	44	60
2008	57	62	57	54	50	40	59
2158	56	63	58	56	48	38	60
2308	58	61	60	58	49	39	61
2528	61	62	59	55	49	41	60
2628	58	61	61	59	49	39	62
3028	63	63	60	56	48	42	61
3428	63	61	58	54	53	52	61
3828	63	61	58	54	53	52	61
4008	63	64	66	59	57	54	66
4408	63	61	58	56	55	53	62
4608	64	62	59	57	55	53	63

SOUND LEVELS

ST-HE versions with SUPER LOW NOISE option

■ **Sound power levels ref $10^{-12} \text{ W} \pm 3 \text{ dB (Lw)}$**

At nominal EN 14511-3: 2013 operating conditions in cooling mode

POWERCIAT LX ST-HE	SOUND POWER LEVEL SPECTRUM (dB)						Overall power level dB(A)
	125 Hz	250 Hz	500 Hz	1000 Hz	2000 Hz	4000 Hz	
1358	86	93	84	85	78	69	89
1528	88	92	85	85	79	70	89
1858	88	93	88	86	80	77	91
2008	90	92	87	85	81	72	90
2158	90	93	89	86	80	73	91
2308	92	92	90	88	81	75	92
2528	91	91	90	86	80	73	91
2628	93	91	91	89	81	76	93
3028	92	91	92	87	81	74	92
3428	96	92	89	87	85	84	93
3828	96	92	89	87	86	84	93
4008	94	95	97	90	88	85	97
4408	96	94	91	87	86	85	94
4608	97	95	92	89	87	85	95

■ **Sound pressure levels ref $2 \times 10^{-5} \text{ Pa} \pm 3 \text{ dB (Lp)}$**

Measurement conditions: free field, 10 metres from machine, 1.50 metres above floor level, directivity 2

POWERCIAT LX ST-HE	SOUND PRESSURE SPECTRUM (dB)						Overall pressure level dB(A)
	125 Hz	250 Hz	500 Hz	1000 Hz	2000 Hz	4000 Hz	
1358	54	61	51	52	46	37	57
1528	55	59	52	53	46	38	57
1858	56	61	56	54	47	44	58
2008	57	59	55	53	48	40	57
2158	57	61	56	54	47	40	58
2308	59	59	57	55	48	42	59
2528	58	58	57	53	48	41	58
2628	60	59	59	57	48	44	60
3028	59	58	59	54	48	42	59
3428	63	59	56	54	52	51	60
3828	63	59	56	53	52	51	60
4008	61	62	64	57	55	52	64
4408	63	61	58	54	53	52	61
4608	64	62	59	56	54	52	62

SOUND LEVELS

XE versions

■ **Sound power levels ref $10^{-12} \text{ W} \pm 3 \text{ dB (Lw)}$**

At nominal EN 14511-3: 2013 operating conditions in cooling mode

POWERCAT LX XE	SOUND POWER LEVEL SPECTRUM (dB)						Overall power level dB(A)
	125 Hz	250 Hz	500 Hz	1000 Hz	2000 Hz	4000 Hz	
0808	95	94	91	98	86	80	99
0908	95	94	91	98	86	80	99
1008	95	94	92	98	86	80	99
1108	96	95	94	97	87	83	99
1358	103	106	94	96	88	84	101
1528	95	93	95	96	91	86	99
1858	103	105	96	96	91	86	101
2008	96	93	95	96	91	86	99
2158	104	107	97	99	91	86	103
2308	98	101	98	101	93	88	103
2528	98	98	97	98	92	89	101
2628	99	103	98	102	91	87	104
3028	101	101	98	99	91	90	102
3428	100	103	100	99	93	88	103
3828	100	103	99	98	93	88	102
4008	101	102	102	101	93	88	104
4408	100	102	102	101	93	88	104
4608	101	102	102	101	93	88	104

■ **Sound pressure levels ref $2 \times 10^{-5} \text{ Pa} \pm 3 \text{ dB (Lp)}$**

Measurement conditions: free field, 10 metres from machine, 1.50 metres above floor level, directivity 2

POWERCAT LX XE	SOUND PRESSURE SPECTRUM (dB)						Overall pressure level dB(A)
	125 Hz	250 Hz	500 Hz	1000 Hz	2000 Hz	4000 Hz	
0808	63	62	59	66	54	48	67
0908	63	62	59	66	54	48	67
1008	63	62	60	66	54	48	67
1108	64	63	62	65	55	51	67
1358	71	74	62	64	56	52	69
1528	63	61	63	64	59	54	67
1858	70	72	63	63	58	53	68
2008	63	60	62	63	58	53	66
2158	71	74	64	66	58	53	70
2308	65	68	65	68	60	55	70
2528	65	65	64	65	59	56	68
2628	66	70	65	69	58	54	71
3028	68	68	65	66	58	57	69
3428	67	70	67	66	60	55	70
3828	67	70	66	65	60	55	69
4008	68	69	69	68	60	55	71
4408	67	69	69	68	60	55	71
4608	68	69	69	68	60	55	71

SOUND LEVELS

XE versions with Low Noise option

■ Sound power levels ref $10^{-12} \text{ W} \pm 3 \text{ dB (Lw)}$

At nominal EN 14511-3: 2013 operating conditions in cooling mode

POWERCIAT LX XE	SOUND POWER LEVEL SPECTRUM (dB)						Overall power level dB(A)
	125 Hz	250 Hz	500 Hz	1000 Hz	2000 Hz	4000 Hz	
0808	93	93	90	90	82	78	93
0908	93	93	90	90	82	78	93
1008	94	94	91	91	83	79	94
1108	95	94	92	91	85	80	95
1358	95	93	92	91	87	80	95
1528	95	93	93	91	86	81	95
1858	97	95	94	93	89	82	97
2008	96	93	94	92	87	82	96
2158	100	98	93	93	86	81	97
2308	97	96	95	95	87	82	98
2528	97	94	95	93	87	82	97
2628	98	96	96	97	88	82	99
3028	100	94	95	95	88	84	98
3428	101	97	95	92	90	87	98
3828	101	97	95	92	90	87	98
4008	101	98	98	95	91	88	100
4408	101	99	96	94	90	87	99
4608	102	98	96	94	91	87	99

■ Sound pressure levels ref $2 \times 10^{-5} \text{ Pa} \pm 3 \text{ dB (Lp)}$

Measurement conditions: free field, 10 metres from machine, 1.50 metres above floor level, directivity 2

POWERCIAT LX XE	SOUND PRESSURE SPECTRUM (dB)						Overall pressure level dB(A)
	125 Hz	250 Hz	500 Hz	1000 Hz	2000 Hz	4000 Hz	
0808	61	61	58	58	50	45	61
0908	61	61	58	58	50	45	61
1008	62	61	59	58	51	46	62
1108	62	62	60	59	53	48	63
1358	62	61	60	59	54	48	63
1528	62	60	61	58	53	48	63
1858	64	63	61	61	56	50	64
2008	64	61	62	59	54	49	63
2158	68	65	61	61	53	49	64
2308	65	63	63	62	55	50	65
2528	65	62	62	61	54	50	64
2628	65	64	63	64	55	50	66
3028	67	62	62	62	55	51	65
3428	68	64	62	59	57	54	65
3828	68	64	62	59	57	54	65
4008	68	65	65	62	58	55	67
4408	68	65	63	61	57	54	66
4608	68	65	63	61	58	54	66

SOUND LEVELS

XE versions with XTRA LOW NOISE option

■ Sound power levels ref $10^{-12} \text{ W} \pm 3 \text{ dB (Lw)}$

At nominal EN 14511-3: 2013 operating conditions in cooling mode

POWERCAT LX XE	SOUND POWER LEVEL SPECTRUM (dB)						Overall power level dB(A)
	125 Hz	250 Hz	500 Hz	1000 Hz	2000 Hz	4000 Hz	
0808	89	89	83	84	76	64	87
0908	89	89	83	84	76	64	87
1008	89	89	83	84	76	64	87
1108	90	92	87	86	79	67	90
1358	90	96	87	85	79	65	91
1528	92	93	88	87	81	69	91
1858	91	96	91	88	81	75	93
2008	92	94	90	87	82	70	92
2158	92	97	92	90	81	67	94
2308	93	94	92	90	81	69	94
2528	96	96	93	89	81	73	94
2628	93	94	93	92	80	68	95
3028	97	95	93	89	79	73	94
3428	97	94	91	88	86	84	94
3828	97	94	91	88	86	84	94
4008	97	97	99	92	89	87	99
4408	97	94	91	90	87	85	95
4608	98	95	93	91	88	86	96

■ Sound pressure levels ref $2 \times 10^{-5} \text{ Pa} \pm 3 \text{ dB (Lp)}$

Measurement conditions: free field, 10 metres from machine, 1.50 metres above floor level, directivity 2

POWERCAT LX XE	SOUND PRESSURE SPECTRUM (dB)						Overall pressure level dB(A)
	125 Hz	250 Hz	500 Hz	1000 Hz	2000 Hz	4000 Hz	
0808	56	56	51	52	44	32	55
0908	56	56	51	52	44	32	55
1008	56	56	51	52	44	32	55
1108	58	60	55	54	47	35	58
1358	58	63	55	53	47	33	59
1528	59	61	56	54	48	36	59
1858	59	63	58	55	48	43	60
2008	60	61	57	55	49	37	59
2158	60	64	59	57	48	35	61
2308	60	61	60	58	49	36	61
2528	63	63	60	56	49	40	61
2628	60	61	61	59	47	35	62
3028	64	63	60	56	46	40	61
3428	64	61	58	55	52	51	61
3828	64	61	58	55	52	51	61
4008	64	64	66	59	56	53	66
4408	64	61	58	56	54	52	62
4608	65	62	59	57	55	53	63

SYSTEM WATER VOLUME - EVAPORATOR WATER FLOW RATE

The Connect Touch control is equipped with anticipation logic making it highly flexible in adjusting operation to parameter drift, particularly on hydraulic systems with low water volumes. By adjusting compressor running times, it prevents short cycle protection cycles from starting and, in most cases, eliminates the need for a buffer tank.

Note The minimum volumes of chilled water are calculated for EUROVENT rated conditions:

- Chilled water temperature = 12°C/7°C
- Condenser air inlet temperature = 35°C

This value is applicable for most air conditioning applications (unit with fan coil units).

Note:

For installations operating on low water volumes (assembly with air handling unit) or for industrial processes, the addition of a buffer tank is essential.

POWERCIAT LX ST/HE/XE	0808	0908	1008	1108	1358	1528	1858	2008	2158	2308	2528	2628	3028	3428	3828	4008	4408	4608
Minimum water volume/Comfort application	887	969	1056	1271	1437	1622	1989	2207	2350	2551	2733	2880	3172	3718	4053	4310	4657	4826
Minimum water volume/Process application	1775	1937	2113	2542	2873	3244	3978	4414	4700	5103	5467	5759	6344	7436	8106	8619	9315	9653
Minimum flow rate ⁽¹⁾ (l/s)	3,6	4,0	4,3	5,3	6,0	6,7	8,1	8,9	9,6	10,4	11,0	11,8	13,1	15,1	16,4	17,5	16,4	18,8
Maximum flow rate ⁽²⁾ (l/s)	37,5	40,5	40,5	34,1	36,9	42,0	45,0	56,1	59,1	67,1	67,1	73,9	83,9	87,8	126,5	92,9	132,1	107,4

(1) Minimum flow rate for maximum allowable water temperature difference conditions (10K) under Eurovent conditions
 (2) Maximum flow rate for a pressure drop of 100 kPa in the exchanger

OPERATING RANGE

POWERCAT units have a broad field of application, enabling them to meet a range of requirements in the most varied of climates.

Multi-climate: -20 °C to +55 °C

The POWERCAT HE and XE series are equipped as standard with all the management devices and algorithms to enable all-season operation in all climates. The POWERCAT HE and XE series are therefore able to operate in conditions ranging from the heat of the Mediterranean basin to the chill of Scandinavia, the humid Atlantic coast to the dry climate of Central Europe.

On the ST series, winter operation down to -20 °C is optional (standard -10 °C).

Multi-application: air conditioning, industrial processes

The POWERCAT can be used for all traditional air conditioning applications in sectors as varied as collective housing, hotels, shopping centres and offices.

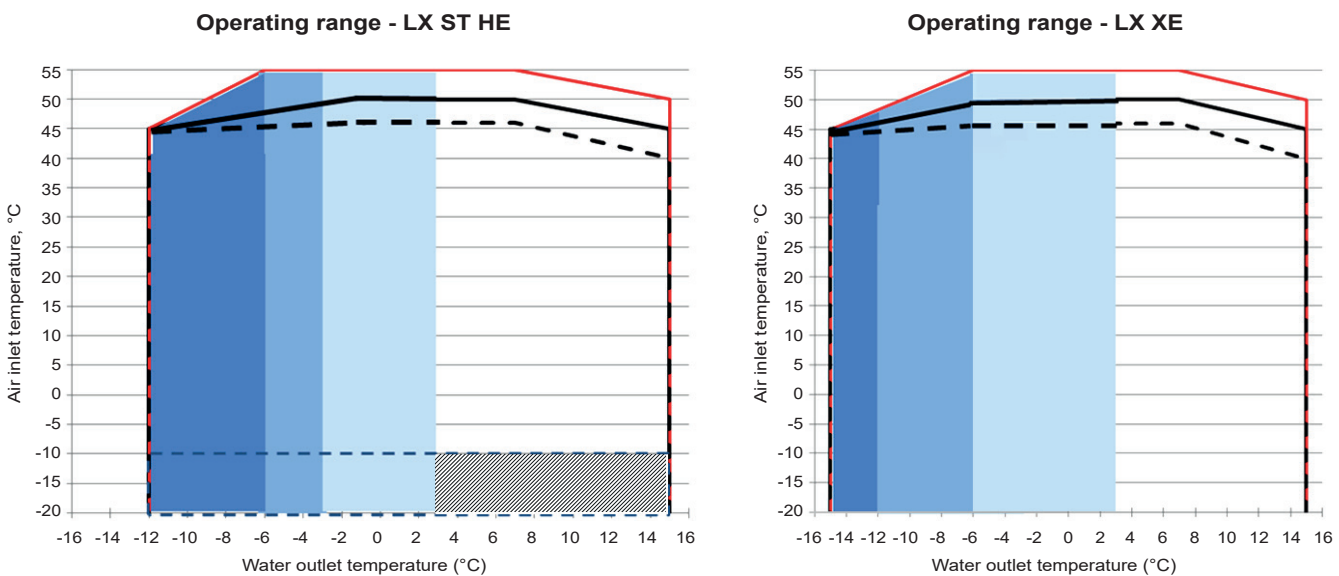

Ranges given as a guide using ethylene glycol for an evaporator $\Delta T = 3K$. Refer to the electronic catalogue.

- Winter operation option for the ST version (standard for HE and XE versions)
- Very low temperature brine, ST-HE (-12°C ethylene glycol / -8°C propylene glycol) / XE (-15°C ethylene glycol / -10°C propylene glycol)
- Medium temperature brine, ST-HE (-6°C ethylene glycol / -3°C propylene glycol) / XE (-12°C ethylene glycol / -8°C propylene glycol)
- Medium temperature brine, ST-HE (-3°C ethylene glycol / 0°C propylene glycol) / XE (-6°C ethylene glycol / -3°C propylene glycol)
- Full load operation
- Part load operation
- Operating limit for units equipped with the Xtra and super low noise options

Power factor correction option available for an inlet air temperature up to +40°C
 For operation in pure water at an inlet air temperature below 0°C, the frost protection option must be provided

HYDRAULIC SPECIFICATIONS

■ Water pressure drop in the evaporator

Data applicable for pure water at 20°C

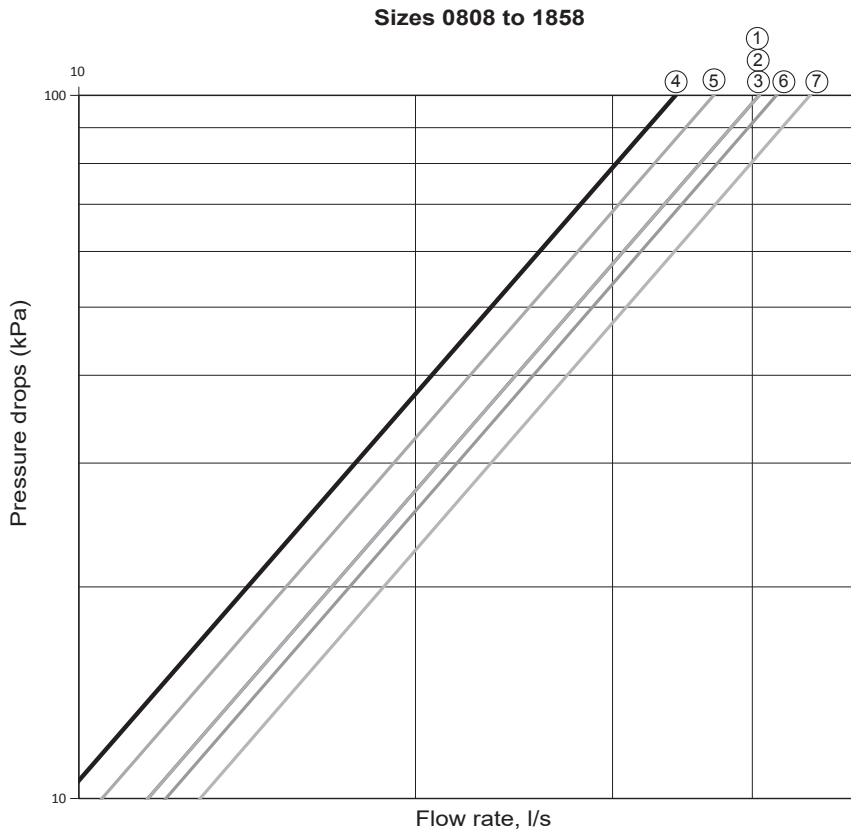

- ① 0808
- ② 0908
- ③ 1008
- ④ 1108
- ⑤ 1358
- ⑥ 1528
- ⑦ 1858

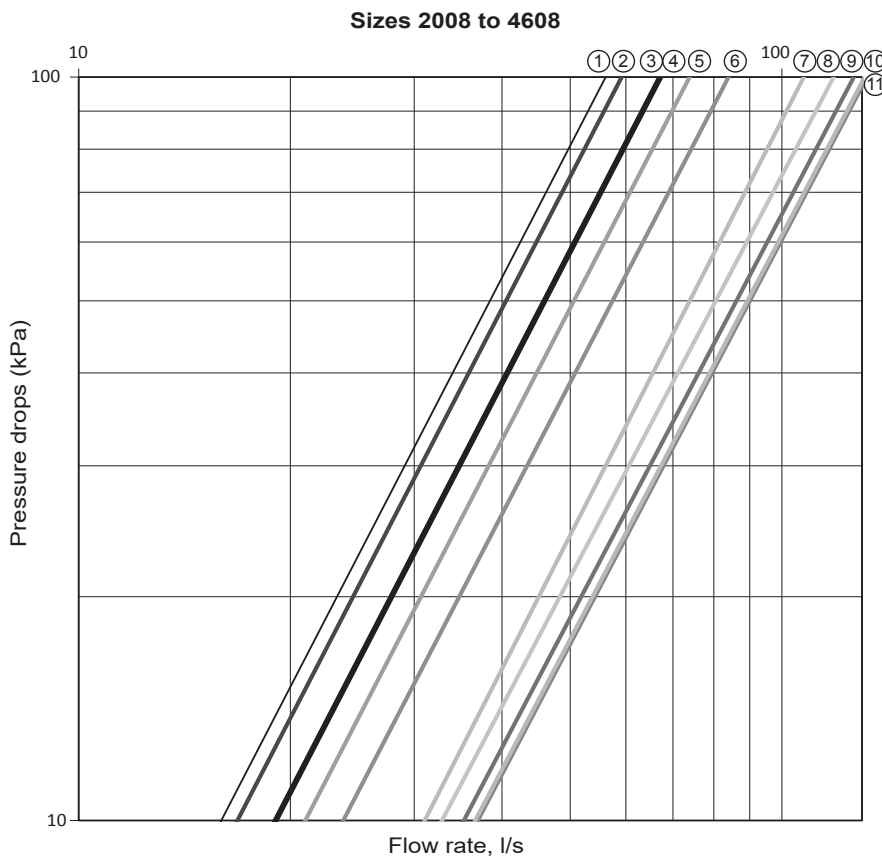

- ① 2008
- ② 2158
- ③ 2308
- ④ 2528
- ⑤ 2628
- ⑥ 3028
- ⑦ 3428
- ⑧ 3828
- ⑨ 4008
- ⑩ 4408
- ⑪ 4608

HYDRAULIC SPECIFICATIONS

■ Available static system pressure

Data applicable for:

- Pure water at 20°C
- Refer to the section "Evaporator water flow rate" for the minimum and maximum water flow rate values
- If a glycol/water mix is used, the maximum water flow rate is reduced

■ High pressure pumps LX ST/HE/XE (fixed speed)

Single pumps

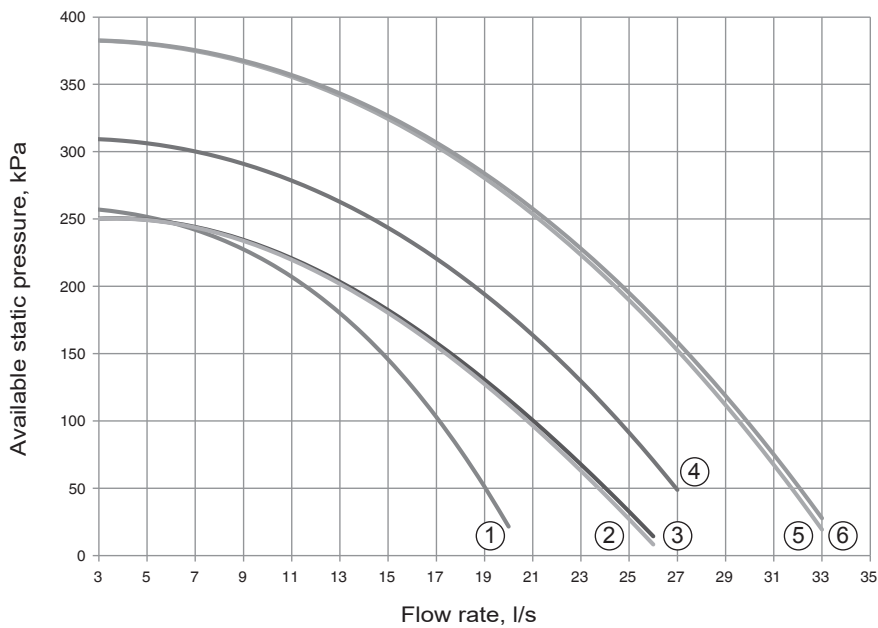

- ① LX 0808
- ② LX 0908
- ③ LX 1008
- ④ LX 1108
- ⑤ LX 1358
- ⑥ LX 1528

■ High pressure pumps LX ST/HE/XE (fixed speed)

Dual pumps

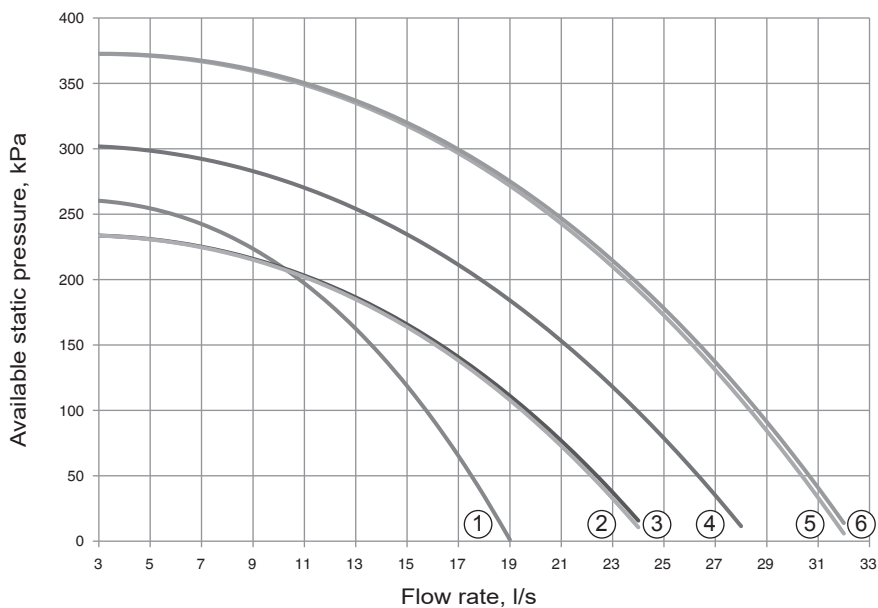

- ① LX 0808
- ② LX 0908
- ③ LX 1008
- ④ LX 1108
- ⑤ LX 1358
- ⑥ LX 1528

HYDRAULIC SPECIFICATIONS

■ Available static system pressure

Data applicable for:

- Pure water at 20°C
- Refer to the section "Evaporator water flow rate" for the minimum and maximum water flow rate values
- If a glycol/water mix is used, the maximum water flow rate is reduced

■ Low pressure pumps LX ST/HE/XE (fixed speed)

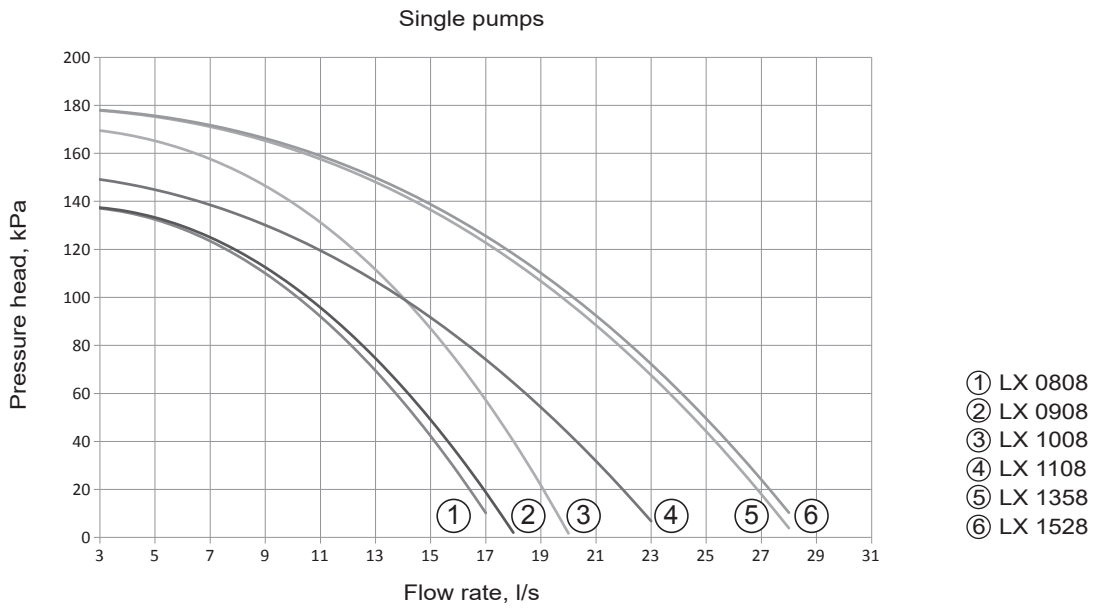

■ Low pressure pumps LX ST/HE/XE (fixed speed)

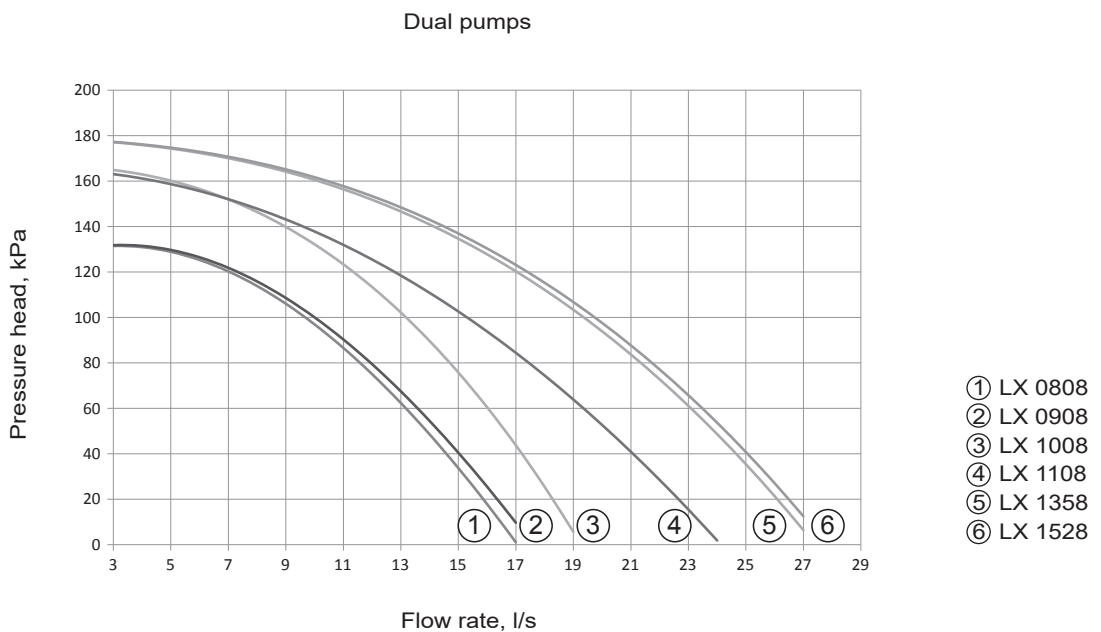

DIMENSIONS

■ POWERCIAT LX ST-HE-XE 0808 to 1008

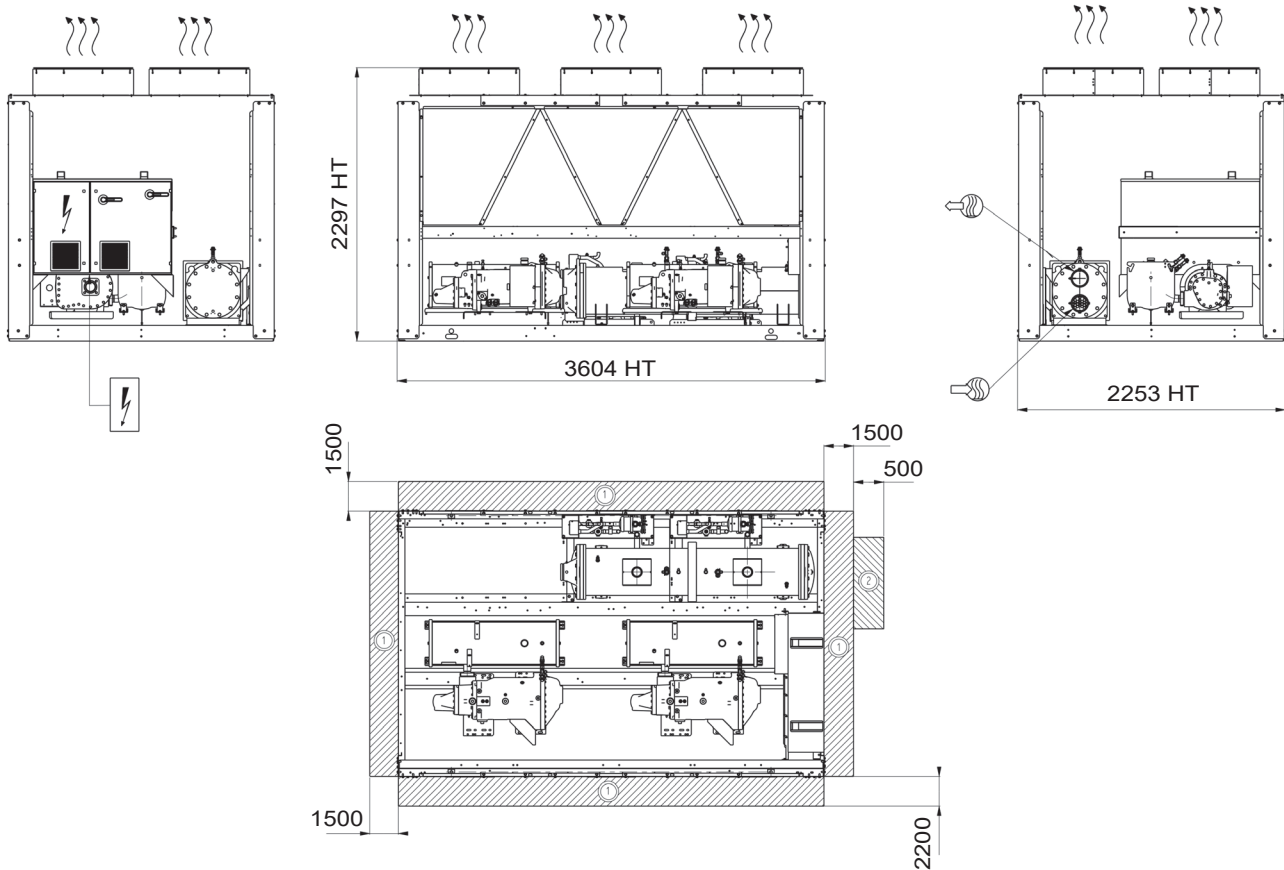

Key
All dimensions in mm

- ① Clearance required for maintenance and air flow
- ② Clearance recommended for coil removal
- Water inlet
- Water outlet
- Air outlet, do not obstruct
- Electrical cabinet

Notes:
Non-contractual drawings.

When designing a system, refer to the certified dimensional drawings provided with the unit or available on request.

Please refer to the certified dimensional drawings for the positioning of the fixing points, weight distribution points and centre of gravity coordinates.

DIMENSIONS

■ POWERCIAT LX ST-HE-XE 1108 to 1358

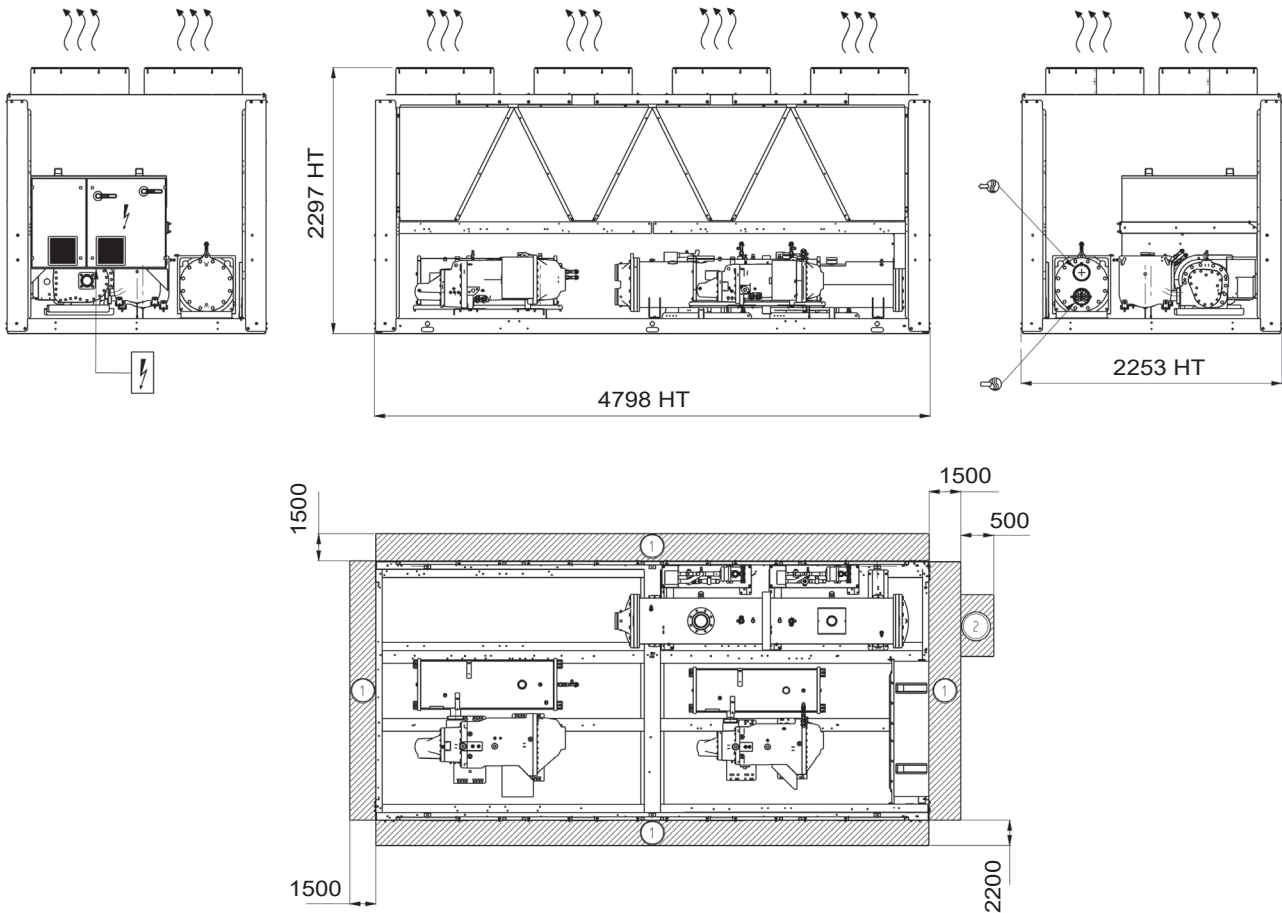

Key
All dimensions in mm

- ① Clearance required for maintenance and air flow
- ② Clearance recommended for coil removal
- Water inlet
- Water outlet
- Air outlet, do not obstruct
- Electrical cabinet

Notes:
Non-contractual drawings.

When designing a system, refer to the certified dimensional drawings provided with the unit or available on request.

Please refer to the certified dimensional drawings for the positioning of the fixing points, weight distribution points and centre of gravity coordinates.

DIMENSIONS

■ POWERCAT LX ST-HE-XE 1528

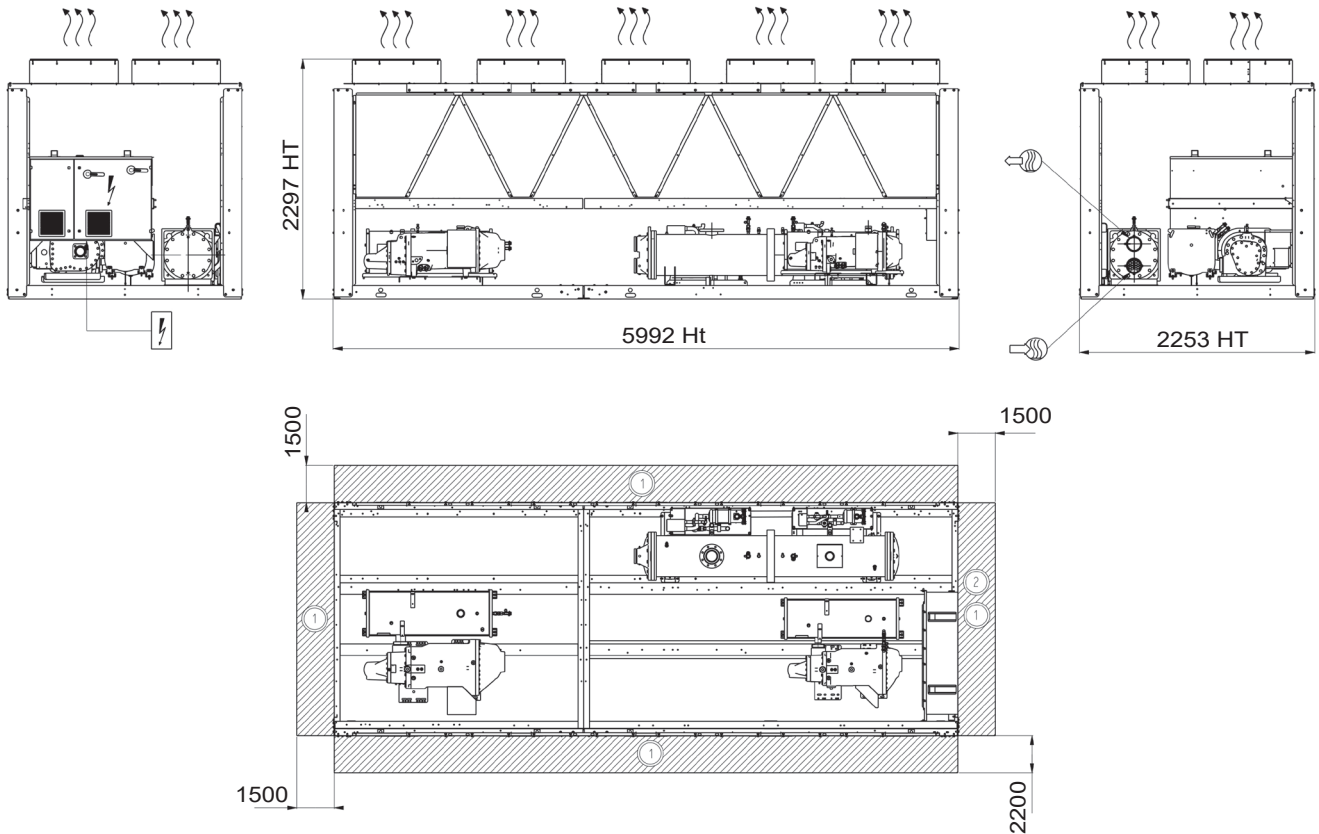

Key
All dimensions in mm

- ① Clearance required for maintenance and air flow
- ② Clearance recommended for coil removal
- Water inlet
- Water outlet
- Air outlet, do not obstruct
- Electrical cabinet

Notes:
Non-contractual drawings.

When designing a system, refer to the certified dimensional drawings provided with the unit or available on request.

Please refer to the certified dimensional drawings for the positioning of the fixing points, weight distribution points and centre of gravity coordinates.

DIMENSIONS

■ POWERCIAT LX ST-HE-XE 1858 to 2308

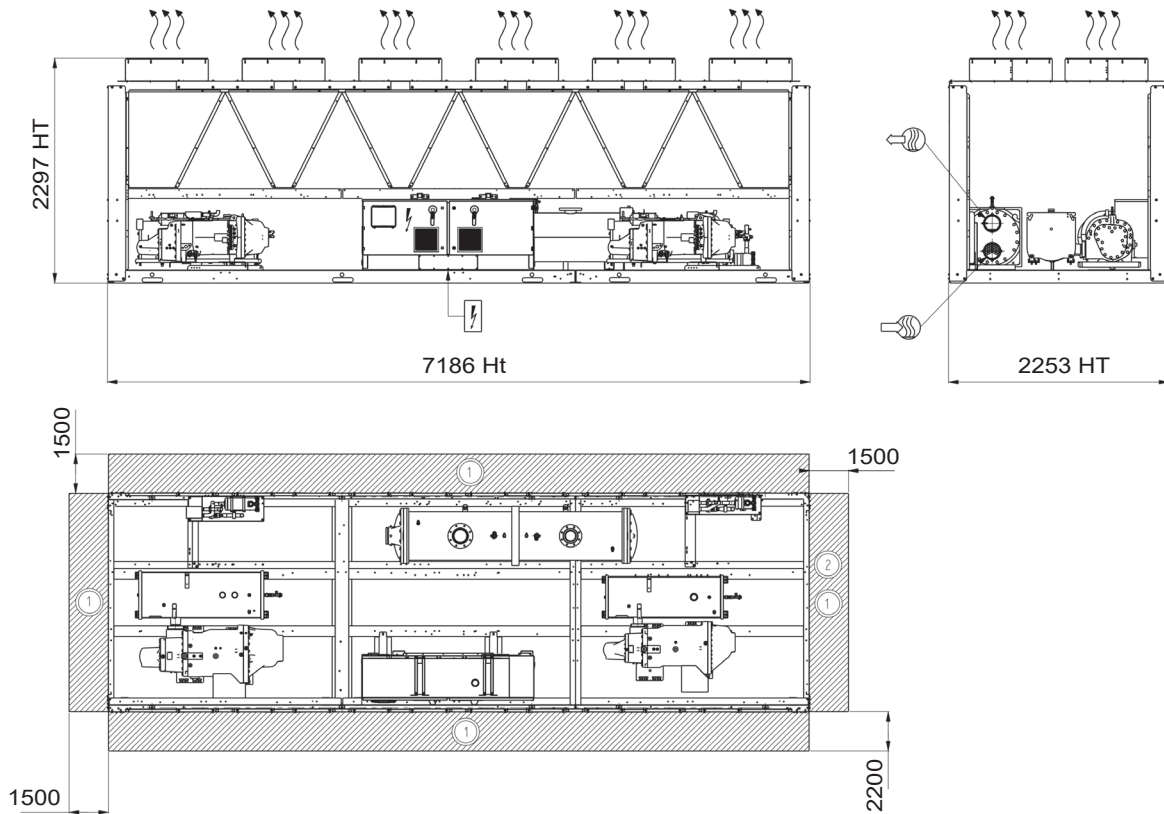

Key
All dimensions in mm

- ① Clearance required for maintenance and air flow
- ② Clearance recommended for coil removal
- Water inlet
- Water outlet
- Air outlet, do not obstruct
- Electrical cabinet

Notes:
Non-contractual drawings.

When designing a system, refer to the certified dimensional drawings provided with the unit or available on request.

Please refer to the certified dimensional drawings for the positioning of the fixing points, weight distribution points and centre of gravity coordinates.

DIMENSIONS

■ POWERCIAT LX ST-HE-XE 2528 to 2628

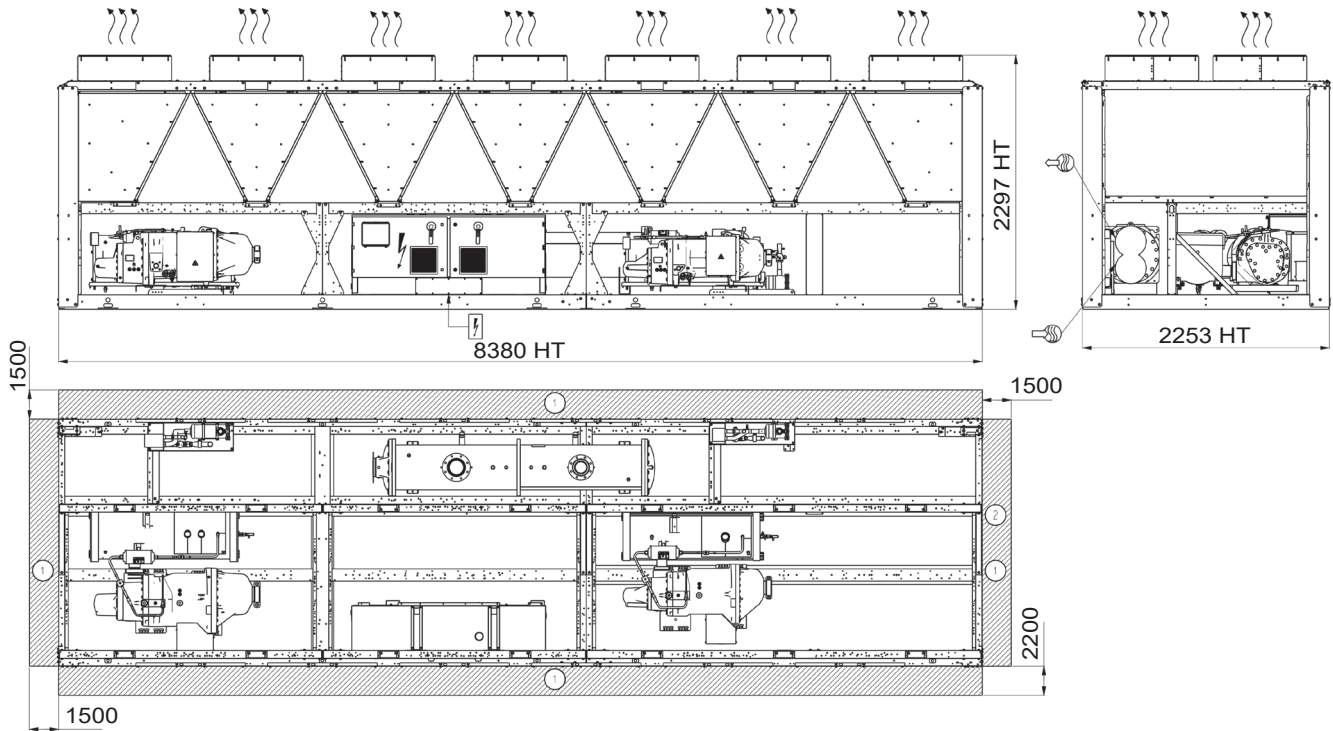

Key
All dimensions in mm

- ① Clearance required for maintenance and air flow
- ② Clearance recommended for coil removal
- Water inlet
- Water outlet
- Air outlet, do not obstruct
- Electrical cabinet

Notes:
Non-contractual drawings.

When designing a system, refer to the certified dimensional drawings provided with the unit or available on request.



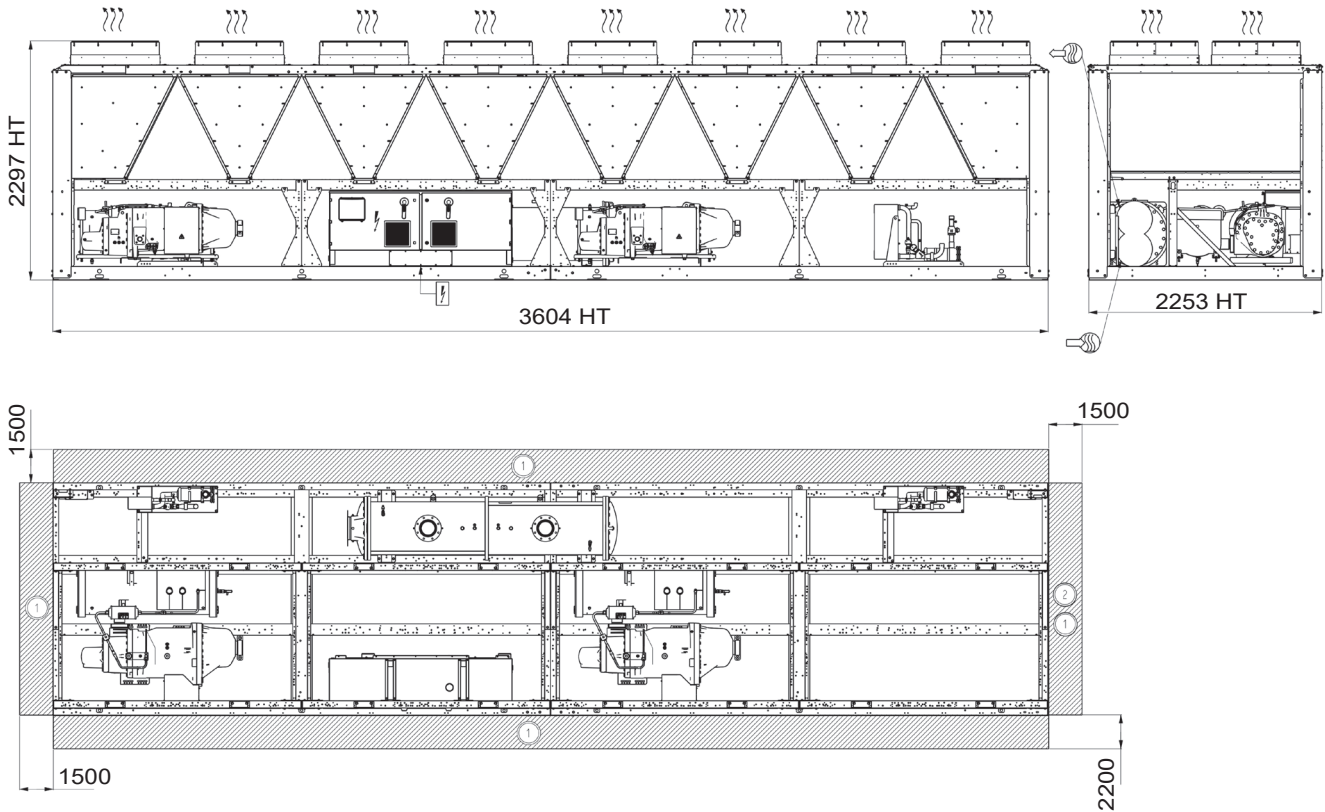

Please refer to the certified dimensional drawings for the positioning of the fixing points, weight distribution points and centre of gravity coordinates.

DIMENSIONS

■ POWERCIAT LX ST-HE-XE 3028



Key
All dimensions in mm

- ① Clearance required for maintenance and air flow
- ② Clearance recommended for coil removal
-  Water inlet
-  Water outlet
-  Air outlet, do not obstruct
-  Electrical cabinet

Notes:
Non-contractual drawings.

When designing a system, refer to the certified dimensional drawings provided with the unit or available on request.

Please refer to the certified dimensional drawings for the positioning of the fixing points, weight distribution points and centre of gravity coordinates.

DIMENSIONS

■ POWERCAT LX ST-HE-XE 3428 to 4408

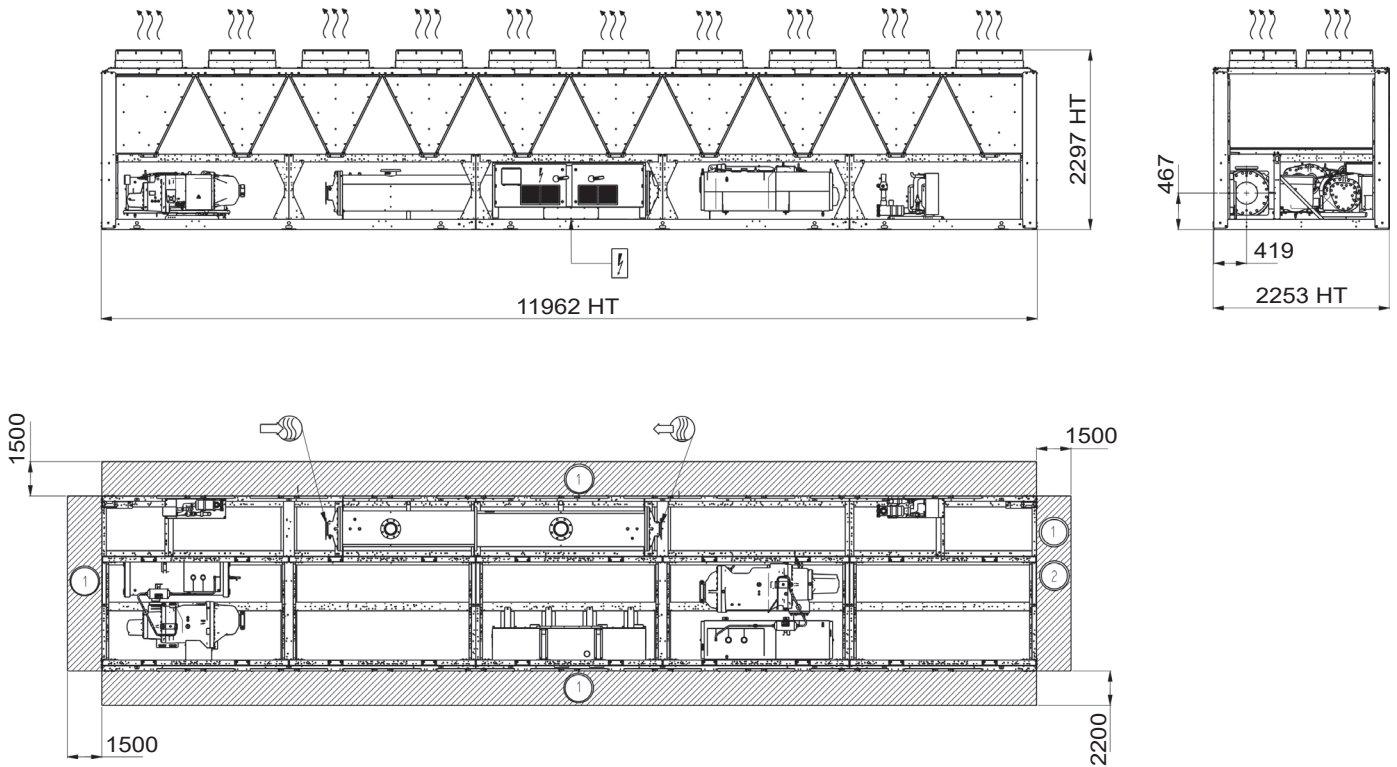

Key
All dimensions in mm

- ① Clearance required for maintenance and air flow
- ② Clearance recommended for coil removal
- Water inlet
- Water outlet
- Air outlet, do not obstruct
- Electrical cabinet

Notes:
Non-contractual drawings.

When designing a system, refer to the certified dimensional drawings provided with the unit or available on request.

Please refer to the certified dimensional drawings for the positioning of the fixing points, weight distribution points and centre of gravity coordinates.

DIMENSIONS

■ POWERCIAT LX ST-HE-XE 4608

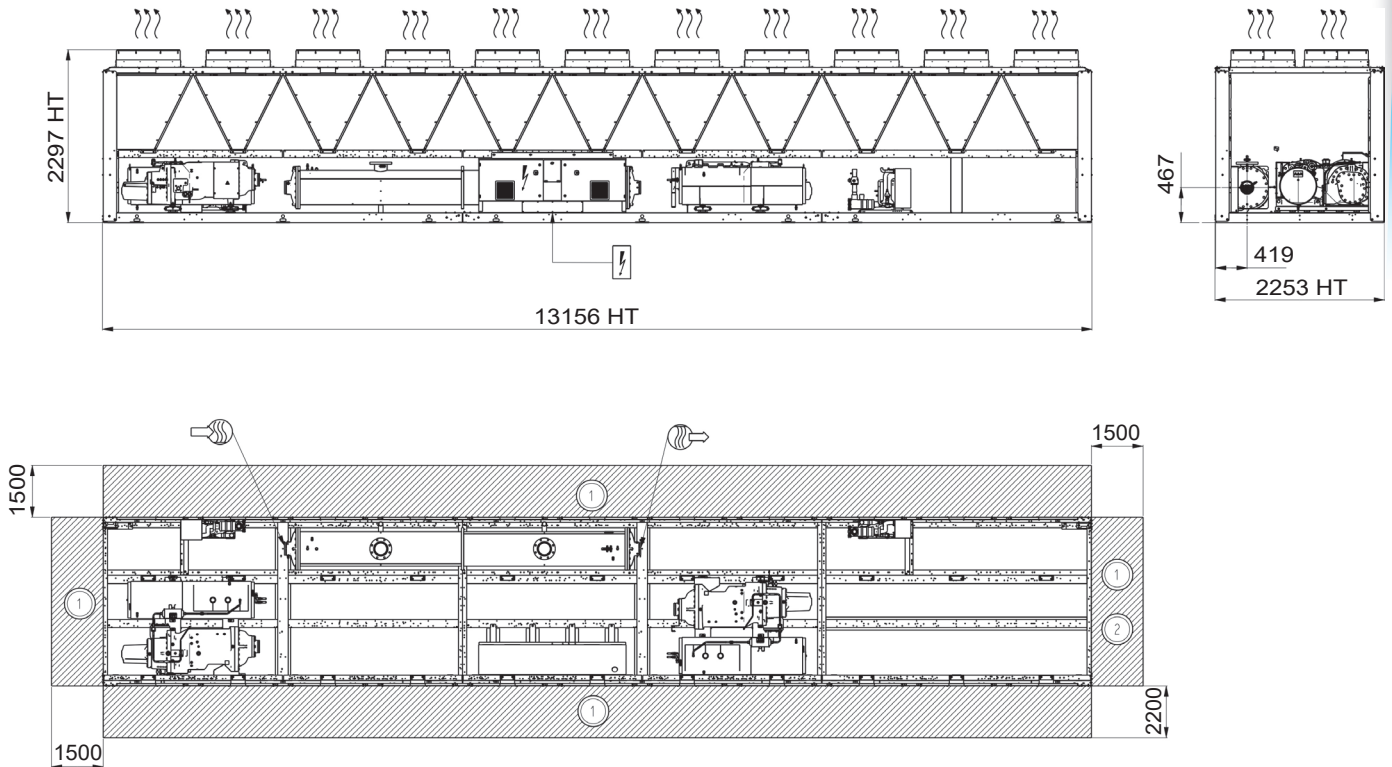

Key
All dimensions in mm

- ① Clearance required for maintenance and air flow
- ② Clearance recommended for coil removal
- Water inlet
- Water outlet
- Air outlet, do not obstruct
- Electrical cabinet

Notes:
Non-contractual drawings.

When designing a system, refer to the certified dimensional drawings provided with the unit or available on request.

Please refer to the certified dimensional drawings for the positioning of the fixing points, weight distribution points and centre of gravity coordinates.

INSTALLATION RECOMMENDATIONS

■ Water quality criteria to be respected

The quality of the water used has a direct impact on the correct and compliant operation of the machine and its service life. This is particularly true if the water used clogs or corrodes components or promotes the growth of algae or micro-organisms. The water must be tested to determine whether it is suitable for the unit. It is also tested to determine whether chemical treatment is necessary and will suffice to make it of acceptable quality. This analysis should confirm whether or not the various machine components are compatible with the water they come into contact with on-site.

Warning: failure to follow these instructions will result in the immediate voiding of the unit's warranty.

■ Lifting and handling

The utmost safety precautions must be taken when lifting and handling the unit.

Always follow the lifting diagram on the unit and in the instruction manual.

Before attempting to lift the unit, make sure the path leading to its intended location is free from obstacles. Always keep the unit vertical when moving it. Never tip it or lie it on its side.

■ Choosing a location for the unit

POWERCAT units are designed for outdoor installation. Precautions should be taken to protect the unit from freezing temperatures. Special attention should be paid to ensure sufficient free space (including at the top) to allow maintenance. The unit must be placed on a perfectly level, fireproof surface strong enough to support it when ready for operation. Noise pollution from auxiliary equipment such as pumps should be studied thoroughly.

Potential noise transmission routes should be studied, with assistance from an acoustical engineer if necessary, before installing the unit. It is strongly recommended that flexible couplings are placed over pipes and anti-vibration mounts are fitted underneath the unit (equipment available as an option) to reduce vibrations, and the noise this causes, as much as possible.

■ Fitting accessories supplied separately

A number of optional accessories may be delivered separately and installed on the unit on site.

You must follow the instructions in the manual.

■ Electrical connections

You must follow the instructions in the manual. All information concerning electrical connections is stated on the wiring diagrams provided with the unit. Always follow this information to the letter.

Electrical connections must be made in accordance with best current practices and applicable standards and regulations. Electrical cable connections to be made on-site:

- Electrical power supply to unit
- contacts available as standard enabling the machine to be controlled remotely (optional)

It should be noted that the unit's electrical system is not protected against lightning strikes.

Therefore devices to protect against transient voltage surges must be installed on the system and inside the power supply unit.

■ Pipe connections

You must follow the instructions in the manual. All pipes must be correctly aligned and slope towards the system's drain valve. Pipes must be installed to allow sufficient access to the panels for maintenance, and must be fitted with heat insulation.

Pipe fixings and brackets must be separate to avoid vibrations and ensure no pressure is placed on the unit. Water flow shut-off and control valves must be fitted when the unit is installed. Pipe connections to be made on site:

- water supply with pressure-reducing valve
 - evaporator, condenser and drain
- Accessories essential to any hydraulic circuit must also be installed, such as:
- water expansion vessel
 - drain nozzles at pipe low points
 - exchanger shut-off valves equipped with filters
 - air vents at pipe high points
 - Check the system's water capacity (install a buffer water tank if necessary)
 - flexible couplings on exchanger inlets and outlets

Warning:

- Pressure in the water circuits below 4 bar for units equipped with the hydraulic module
- Place the expansion vessel upstream of the pump.
- Do not place any valves on the expansion vessel.
- Make sure the water circulation pumps are placed directly at the exchanger inlets.
- Make sure the pressure of the water drawn in by the circulation pumps is greater than or equal to the required minimum pressure (NPSH), particularly if the water circuits are "open".
- Test the water quality in accordance with the relevant technical specifications.
- Take the necessary precautions to protect the unit and hydraulic system from freezing temperatures (e.g. allow for the possibility of draining the unit). If glycol is added to prevent freezing, check its type and concentration before system start-up.
- Before making any final hydraulic connections, flush the pipes with clean water to remove any debris in the network.

■ System start-up

System start-up for these machines must be performed by CIAT or a CIAT-authorized firm.

You must follow the instructions in the manual.

List of system start-up checks (non-exhaustive):

- Correct positioning of unit
- Power supply protections
- Phases and direction of rotation
- Wiring connections on unit
- Direction of water flow in unit
- Cleanliness of water circuit
- Water flow rate at specified value
- Pressure in the refrigerating circuit
- Direction of rotation of compressors
- Water pressure drops and flow rates
- Operating readings

■ Maintenance operations

Specific preventive maintenance operations are required at regular intervals and should be performed by CIAT-approved contractors.

The operating parameters are read and noted on a "CHECK LIST" form to be returned to CIAT.

To do this, you must refer to and comply with the instruction manual.

You must take out a maintenance contract with a CIAT-approved refrigeration equipment specialist. Such a contract is required even during the warranty period.

CONTROL

USER-FRIENDLY INTERFACE CONSOLE

- User-friendly 5 inch touch screen.
- Information displayed in a choice of languages.
- Temperature and pressure readings.
- Operating and fault status diagnostics.
- Master/slave control of two machines in parallel.
- Fault memory management.
- Pump management.
- Time schedule.
- IP web server
- Programmable maintenance
- Preventive maintenance
- F-GAS maintenance
- E-mail alert



REMOTE M2M MACHINE SUPERVISION

Two years of Full Serenity with:

- Monitoring of machine operation (operation overviews and curves, alarm logs).
- E-mail alerts for alarms (optional SMS alerts).
- Remote update of the M2M.
- Access to a log of machine operation data.
- Remote advice for using M2M.
- System start-up and operating readings.

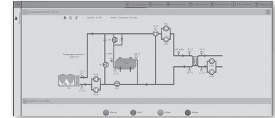

PRODUCT FUNCTIONALITY

POTENTIAL-FREE (DRY) CONTACTS AVAILABLE AS STANDARD

- Inputs:**
- Automatic operation control
 - Selection of setpoints 1 / 2
 - Power limitation.

- Outputs:**
- General fault reporting
 - Operational status reporting

Additional inputs available as options:

- Setpoint adjustable by 4-20 mA signal
- Power limitation adjustable by 4-20 mA signal
- Second power limitation level
- End of storage signal
- User fault reporting
- Time schedule override

Additional outputs available as options:

- Indication of the power level by 0-10 V signal
- Minor alert reporting
- Unit shut down general fault reporting

COMMUNICATION Customer CMS

Via potential-free (dry) contact

Via BUS BUS

CMS CONNECTIONS

- MODBUS-JBUS RTU (RS485) or TC/IP (standard) open protocol
- LONWORKS protocol (option)
- BACNET IP protocol (option)

CIAT SYSTEM FUNCTIONALITY

Communication with CIAT Energy pool controlled by Power'Control.

Built-in Power'Control:

- Energy optimisation of refrigeration and heating using several generators,
- Manages free cooling capacity
- Uses heat recovery to supply domestic hot water.

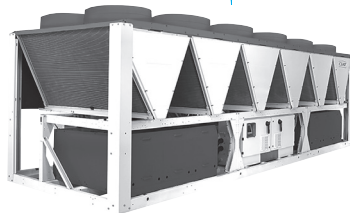



→ Water chillers

POWERCIAT LX

This document is not legally binding. As part of its continuous drive to improve its equipment, CIAT reserves the right to make any technical modifications without prior notice.

Head office

700 Avenue Jean Falconnier - B.P. 14
01350 - Culoz - France
Tel.: +33 (0)4 79 42 42 42
Fax: +33 (0)4 79 42 42 10



CIAT Service

Technical support: 0 892 05 93 93 (€0.34/min)
Spare parts: 0 826 96 95 94 (€0.15/min)
PDRFrance@ciat.fr - PDRGarantie@ciat.fr



Compagnie Industrielle d'Applications Thermiques - S.A. with a registered capital of €26,728,480 - Companies and trade registry. Bourg-en-Bresse B 545 620 114