

CUSTOMER/GRINDER INFORMATION

Company Name: _____
 Contact Name: _____
 Phone: _____ Fax: _____
 Email: _____
 Grinder Brand & Model: _____

Top Hammer Edge:
 Standard is full length coverage. Gaps or removal of a pass is available upon request.

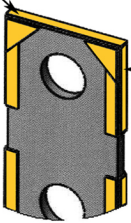

Cutting Edge:
 Length per customer request, up to full length of hammer.

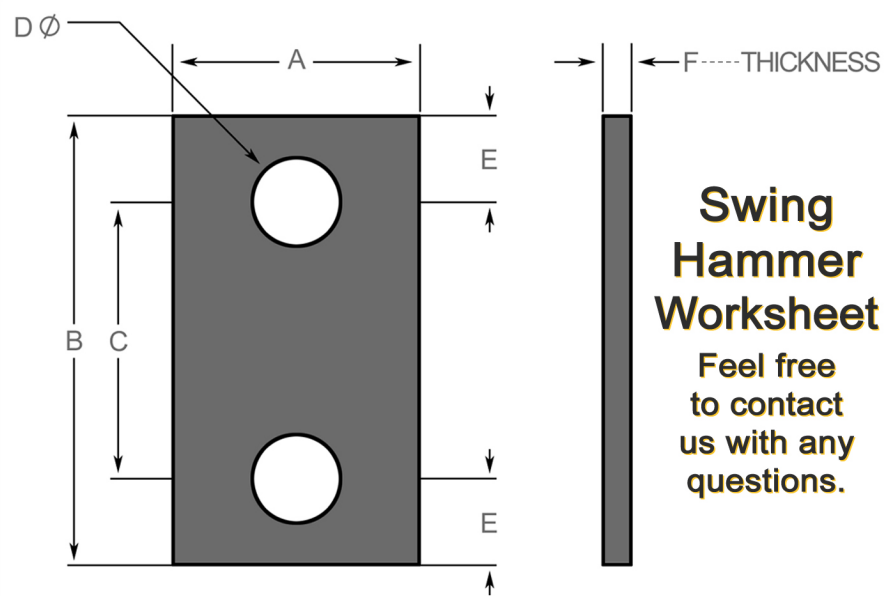

Available Side Weld Patterns Are Below:

Hammer Data (Needed for Ordering)	D:
A:	E:
B:	F:
C:	Carbide Pattern:

0-LW

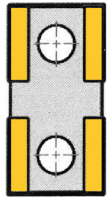

Nothing Across Top other than top end of Wide Weave Vertical Cutting Edge Lines that extend to the top. (Gapped Across Top)

LW-0

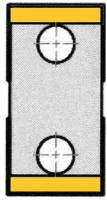

Wide Weave Top Line Only.

LS-0



Single Pass Top Line Only. No Vertical Cutting Edge Lines.

LS-LW



Single Pass Top Line w/ Wide Weave Vertical Cutting Edge Lines.

LW-LW



Wide Weave Top Line w/ Wide Weave Vertical Cutting Edge Lines.

LW-LS

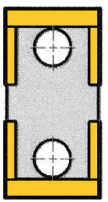

Wide Weave Top Line w/ Single Pass Vertical Cutting Edge Lines.

LS-LS

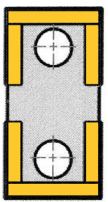

Single Pass Top Line w/ Single Pass Vertical Cutting Edge Lines.

GS-LS



Standard Corner Gusset (Gapped Across Top) w/ Single Pass Vertical Cutting Edge Lines Below Gussets.

GW-LW

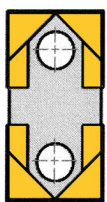

Wide Corner Gusset (Corners Connecting) w/ Wide Weave Vertical Cutting Edge Lines Below Gussets.

GS-0

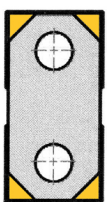

Standard Corner Gusset (Gapped Across Top) No Vertical Cutting Edge Lines.

GW-LS

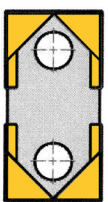

Wide Corner Gusset (Corners Connecting) w/ Single Pass Vertical Cutting Edge Lines Below Gussets.

GW-0

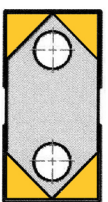

Wide Corner Gusset (Corners Connecting) No Vertical Cutting Edge Lines.