

HIGH EFFICIENCY 14 SEER HEAT PUMP ENVIRONMENTALLY BALANCED R-410A REFRIGERANT

1½ THRU 5 TONS SPLIT SYSTEM

208 / 230 Volt, 1-phase, 60 Hz

REFRIGERATION CIRCUIT

- Scroll compressors on all models
- Suction line accumulator factory installed
- Integrated solid state control with Time-Temperature Defrost
- High and low pressure switches
- Copper tube / aluminum fin coil

EASY TO INSTALL AND SERVICE

- Easy access service valves on all models
- External high and low refrigerant service ports
- Only two screws to access control panel
- Factory charged with R-410A refrigerant

BUILT TO LAST

- Painted cabinet finish over galvanized steel
- Coated inlet grille with 3/8" (10mm) spacing for extra protection

WARRANTY*

- 5 year compressor limited warranty
- 5 year parts limited warranty (including compressor and coil)
- With timely registration, an additional 5 year parts limited warranty (including compressor and coil)

* For residential applications only. See warranty certificate for complete details and restrictions, including warranty coverage for other applications.



Use of the AHRI Certified TM Mark indicates a manufacturer's participation in the program. For verification of certification for individual products, go to www.ahridirectory.org.



UNIT PERFORMANCE DATA							
Model Number	Size (tons)	Nominal Btu/hr	Min. Circuit Ampacity	Max. Fuse or Breaker	Operating Dimensions length x width x height in. (mm)	Operating/Ship Weight lbs. (kg)	Notes
R4H418AKC R4H418GKC	1½	18,000	11.8	20	23-1/8 x 23-1/8 x 35-1/16 (587 x 587 x 891)	136 / 166 (61 / 75)	
R4H424AKC R4H424GKC	2	24,000	14.2	25	25-3/4 x 25-3/4 x 35-1/2 (654 x 654 x 901)	144 / 175 (65 / 79)	
R4H430AKC R4H430GKC	2½	30,000	18.3	30	31-3/16 x 31-3/16 x 31-11/16 (792 x 792 x 804)	158 / 180 (72 / 82)	
R4H436AKC R4H436GKC	3	36,000	20	30	31-3/16 x 31-3/16 x 28-1/4 (792 x 792 x 718)	170 / 201 (77 / 91)	
R4H442AKC R4H442GKC	3½	42,000	24	40	31-3/16 x 31-3/16 x 38-7/16 (792 x 792 x 977)	201 / 235 (91 / 107)	
R4H448AKC R4H448GKC	4	48,000	25.2	40	31-3/16 x 31-3/16 x 28-1/4 (792 x 792 x 718)	197 / 232 (89 / 105)	
R4H460AKC R4H460GKC	5	60,000	32	50	31-3/16 x 31-3/16 x 31-11/16 (792 x 792 x 804)	212 / 248 (96 / 113)	

A = 2" (51mm) spacing inlet grille
G = 3/8" (10mm) spacing inlet grille

Specifications subject to change without notice.

FEM4X Fan Coils



Product Specifications

NOTE: Read the entire instruction manual before starting the installation.

FAN COILS

- 1-1/2 thru 5 tons
- Available for environmentally balanced R-410A systems
- Factory installed TXV metering device
- Sweat connections
- Aluminum Tube, Aluminum Fin Evaporator Coil
- Primary and secondary drain fittings with brass inserts
- Multiple electrical entry locations
- Time delay relay (TDR)
- Field installed heater packages from 5 kW - 30 kW available separately
- HUD approved for manufactured housing
- 208/230-1-60 supply voltage
- Units tested and certified by manufacturer to achieve a 2% or less leakage rate at 1.0 inch water column
- 1 inch thick insulation with R value of 4.2
- Filter (washable) available as accessory
- ECM 5-speed motor
- Multiposition installation - upflow or horizontal left standard, horizontal right with minor modification (field convertible to downflow with available accessory kit)
- Low voltage circuit protective fuse (3amp) inline on wire harness
- No Heat (Plug) Kit factory installed



Use of the AHRI Certified TM Mark indicates a manufacturer's participation in the program. For verification of certification for individual products, go to www.ahridirectory.org.



A200369

LIMITED WARRANTY

- 1 year No Hassle Replacement limited warranty
- 5 year parts limited warranty
- - With timely registration, an additional 5 year parts limited warranty

*For residential applications only. See warranty certificate for completedetails and restrictions, including warranty coverage for other applications.

Model Number	Tons	Nom. CFM (L/s)	Dimensions H x W x D in. (mm)	Filter Size in. (mm)	Ship Wt lbs. (kg)
FEM4X1800BL	1-1/2	600 (283)	42-11/16 x 14-5/16 x 22-1/16 (1084 x 364 x 560)	13 x 21-1/2 (330 x 546)	112 (51)
FEM4X2400CL	2	800 (378)	49-5/8 x 17-5/8 x 22-1/16 (1261 x 448 x 560)	16-3/8 x 21-1/2 (416 x 546)	122 (55)
FEM4X3000BL	2-1/2	1000 (472)	49-5/8 x 17-5/8 x 22-1/16 (1261 x 448 x 560)	16-3/8 x 21-1/2 (416 x 546)	122 (55)
FEM4X3600BL	3	1200 (566)	49-5/8 x 17-5/8 x 22-1/16 (1261 x 448 x 560)	16-3/8 x 21-1/2 (416 x 546)	122 (55)
FEM4X4200BL	3-1/2	1400 (661)	49-5/8 x 21-1/8 x 22-1/16 (1261 x 537 x 560)	19-7/8 x 21-1/2 (505 x 546)	157 (71)
FEM4X4800BL	4	1600 (755)	49-5/8 x 21-1/8 x 22-1/16 (1261 x 537 x 560)	19-7/8 x 21-1/2(505 x 546)	157 (71)
FEM4X6000BL	5	1750 (826)	53-7/16 x 21-1/8 x 22-1/16 (1357 x 537 x 560)	19-7/8 x 21-1/2 (505 x 546)	175 (79)

FAN COIL MODEL NUMBER IDENTIFICATION GUIDE								
DIGIT POSITION	1	2	3	4	5	6,7,8,9	10	11
	F	E	M	4	X	1800	B	L
F = Fan Coil	UNIT							
E = ECM			MOTOR TYPE					
S = Standard PSC								
M = Multiposition								
U = Upflow			INSTALLATION TYPE					
4 = Environmentally Balanced R-410A					REFRIGERANT			
X = TXV							METERING DEVICE	
1800 = 18,000 BTUH = 1-1/2 tons								
2400 = 24,000 BTUH = 2 tons								
3000 = 30,000 BTUH = 2-1/2 tons								
3500 = 36,000 BTUH = 3 tons								
3600 = 36,000 BTUH = 3 tons								
4200 = 42,000 BTUH = 3-1/2 tons								
4800 = 48,000 BTUH = 4 tons								
6000 = 60,000 BTUH = 5 tons							NOMINAL CAPACITY	
B, C							SALES CODE	
L = Aluminum Tube, Aluminum Fin Evaporator Coil							COIL TYPE	

ACCESSORIES PART NUMBER IDENTIFICATION GUIDE					
	EB	AC	01	NCB	A
EB = Evaporator Blower					
AC = Accessory					
01 = Product Identifier Number					
NCB = Non-Combustible Base Kit					
DFK = Down Flow Kit					
PLG = Power Plug (no heat kit)					
SPK = Single Point Wiring Kit					
FKS = Filter Kit Small					
FKM = Filter Kit Medium					
FKL = Filter Kit Large					
FKX = Filter Kit Extra Large					
CTK = Condensate Trap Kit (PVC pipe)					
Sales Code					

ELECTRIC HEATER MODEL NUMBER IDENTIFICATION GUIDE						
	EHK	05	A	K	N	1
EHK = Electric Heater Kit						
05 = 5 kW						
07 = 7 kW						
09 = 9 kW						
10 = 10 kW						
15 = 15 kW						
18 = 18 kW						
20 = 20 kW						
25 = 25 kW						
30 = 30 kW						
	NOMINAL HEAT VALUE					
Sales Code						
K = 208 / 230, single-phase						
H = 208 / 230, 3-phase						
KC = 208 / 230, supplied as single phase, field convertible to 3-phase						
HC = 208 / 230 supplied as 3-phase, field convertible to single phase					VOLTAGE (60 Hz)	
Product Identifier						
Engineering Code						

Manufacturer reserves the right to change, at any time, specifications and designs without notice and without obligations.

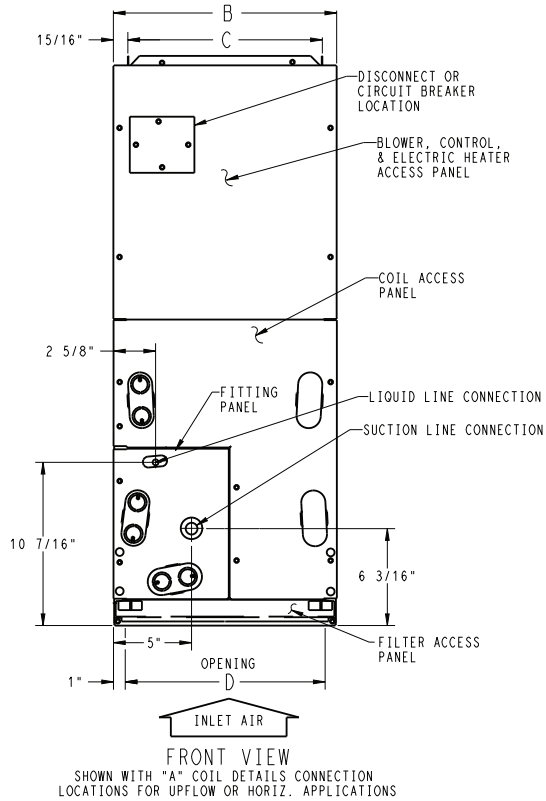
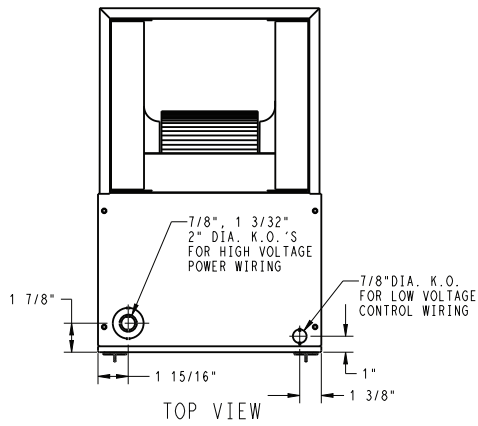

UNIT	SERIES	ELECTRICAL CHARACTERISTICS		A	B	C	D	E	F	G	H	J	COIL CONFIGURATION		SHIPPING WT (LBS)
													SLOPE	"A"	
FEM4X18-B	3,04,05	X	O	42 11/16"	14 5/16"	12 7/16"	12 5/16"	10 7/16"	18 1/8"	18 5/8"	-	12"	X	-	117
FEM4X24-C	2,3,04,05	X	O	49 5/8"	17 5/8"	15 3/4"	15 5/8"	15 3/8"	23 1/8"	23 5/8"	-	17"	X	-	128
FEM4X30-B	2,3,04,05	X	O	49 5/8"	17 5/8"	15 3/4"	15 5/8"	15 3/8"	23 1/8"	23 5/8"	-	17"	X	-	128
FEM4X36-B	4,5,6,07,08,09,10	X	O	49 5/8"	17 5/8"	15 3/4"	15 5/8"	15 3/8"	23 1/8"	23 5/8"	-	17"	X	-	128
FEM4X42-B	2,03,04	X	*	49 5/8"	21 1/8"	19 1/4"	19 1/8"	15 11/16"	23 7/16"	23 1/8"	-	-	-	X	163
FEM4X48-B	2,3,4,05,06,07,08	X	*	49 5/8"	21 1/8"	19 1/4"	19 1/8"	15 11/16"	23 7/16"	23 1/8"	-	-	-	X	162
FEM4X60-B	3,4,5,06,07,08,09	X	*	53 7/16"	21 1/8"	19 1/4"	19 1/8"	19 1/2"	27 1/4"	26 15/16"	28 5/16"	-	-	X	180

208/230-1-60	
208/230-3-60	

X=YES
O=NO
*=YES, DUE TO AVAILABLE FIELD INSTALLED HEATERS.

NOTE:

- SERIES DESIGNATION IS THE 12TH POSITION OF UNIT PRODUCT NUMBER.
- ALL DIMENSIONS ARE IN "INCHES" UNLESS NOTED.

NOTE: ALLOW 21" FROM FRONT FOR SERVICE

UNIT CONNECTION SIZES

SUCTION: 18 & 24 - 5/8" I.D. SWEAT
30 & 36 - 3/4" I.D. SWEAT
42 THRU 60 - 7/8" I.D. SWEAT
LIQUID: 3/8" I.D. SWEAT
CONDENSATE: 3/4" FPT

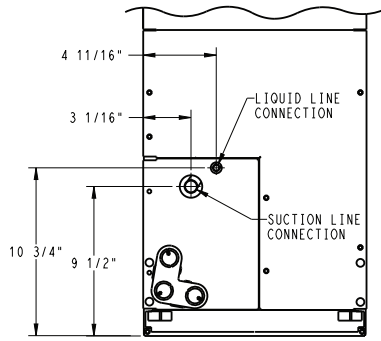

SLOPE COIL DETAILS
CONNECTION LOCATIONS SHOWN FOR UPFLOW OR HORIZ. LEFT APPLICATIONS

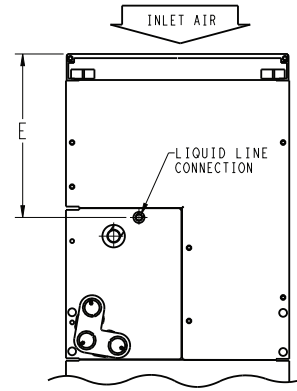

ACCESS PANEL CONFIG. FOR SLOPE COILS DOWNFLOW OR HORIZ. RIGHT APPLICATIONS AND "A" COILS DOWNFLOW APPLICATIONS

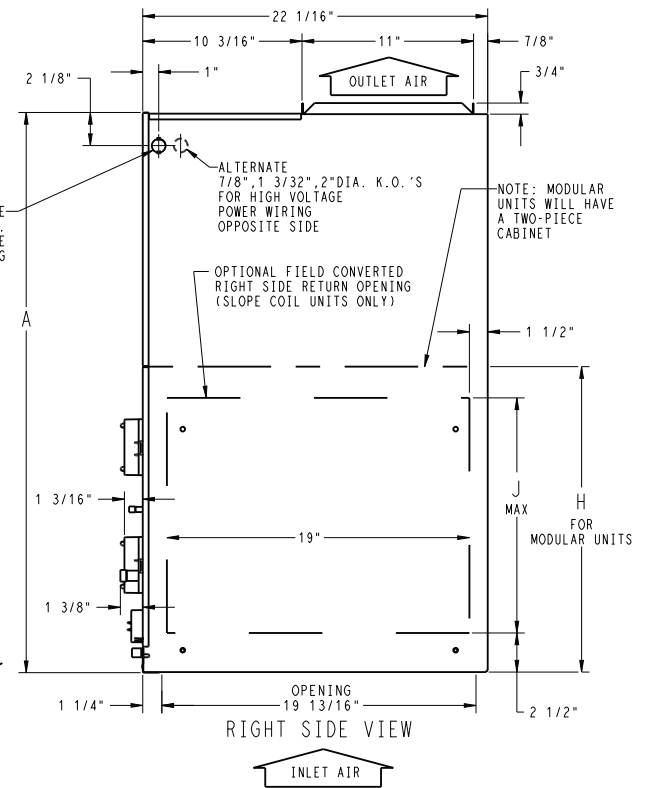

RIGHT SIDE VIEW

Fig. 1 – FEM4X (English)

SLOPE COIL

NOTES:

1. CONDENSATE PAN DRAIN CAPS NOT SHOWN FOR CLARITY.
2. ALL DIMENSIONS ARE IN "INCHES" UNLESS NOTED.

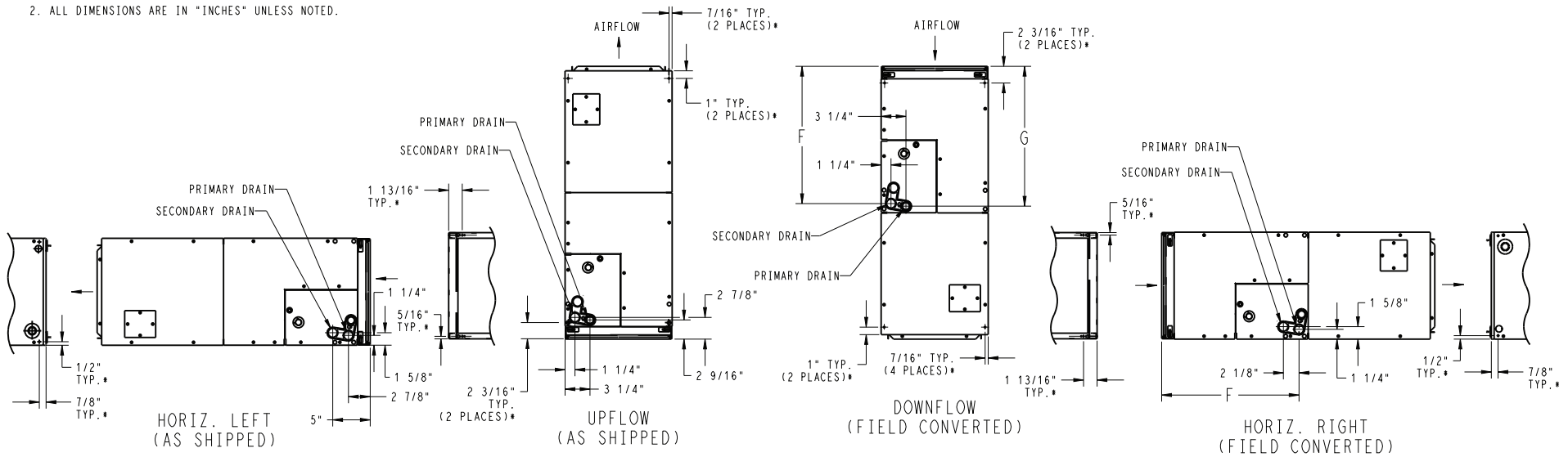

* HORIZONTAL MOUNT LOCATIONS - DIMPLES PROVIDED IN TOP PANEL, AND BACK OF CABINET. IN CABINET BOTTOM. HOLES PROVIDED .136" DIA. HORIZONTAL HANGING HARDWARE TO BE FIELD SUPPLIED.

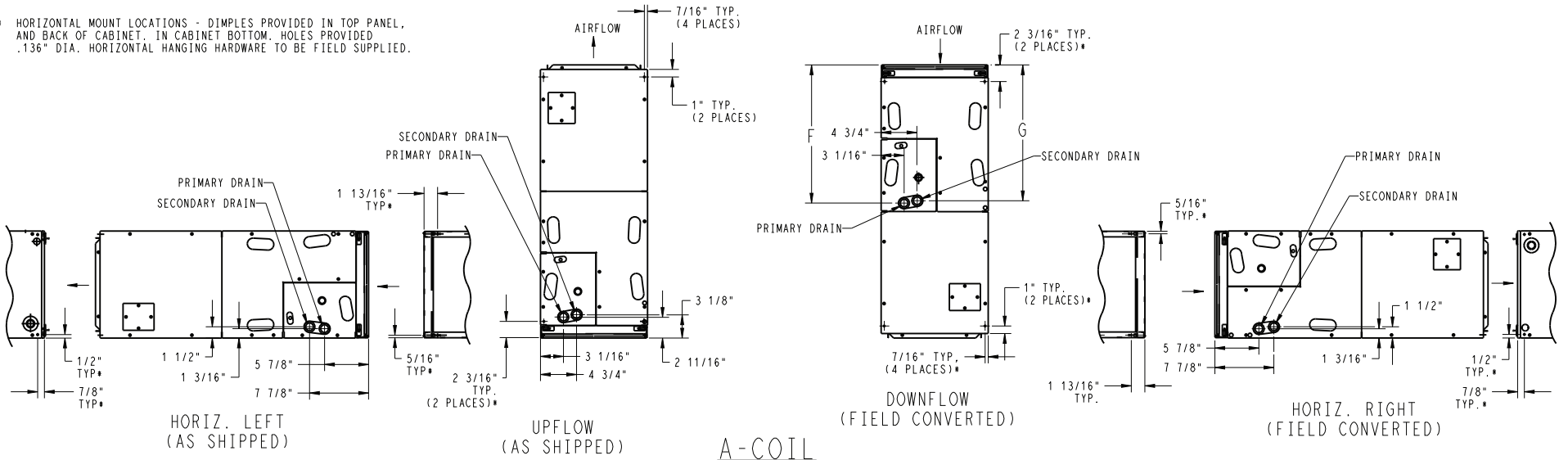

A-COIL

Fig. 2 – FEM4X Slope Coil (English)

A200371

Manufacturer reserves the right to change, at any time, specifications and designs without notice and without obligations.

Manufacturer reserves the right to change, at any time, specifications and designs without notice and without obligations.

UNIT	SERIES	ELECTRICAL CHARACTERISTICS		A	B	C	D	E	F	G	H	J	COIL CONFIGURATION		SHIPPING WT (Kgs)
													SLOPE	"A"	
FEM4X18-B	3,04,05	X	O	1084.3	363.6	315.9	312.8	265.1	460.4	473.1	-	304.8	X	-	53.1
FEM4X24-C	2,3,04,05	X	O	1260.5	447.7	400.0	396.9	390.5	587.4	600.1	-	431.8	X	-	58.1
FEM4X30-B	2,3,04,05	X	O	1260.5	447.7	400.0	396.9	390.5	587.4	600.1	-	431.8	X	-	58.1
FEM4X36-B	4,5,6,07,08,09,10	X	O	1260.5	447.7	400.0	396.9	390.5	587.4	600.1	-	431.8	X	-	58.1
FEM4X42-B	2,03,04	X	*	1260.5	536.6	489.0	485.8	398.5	595.3	587.4	-	-	-	X	74.0
FEM4X48-B	2,3,4,05,06,07,08	X	*	1260.5	536.6	489.0	485.8	398.5	595.3	587.4	-	-	-	X	73.6
FEM4X60-B	3,4,5,06,07,08,09	X	*	1357.3	536.6	489.0	485.8	495.3	692.2	684.2	719.2	-	-	X	81.7

208/230-1-60	
208/230-3-60	

X=YES
O=NO
*=YES, DUE TO AVAILABLE FIELD INSTALLED HEATERS.

NOTE:

- SERIES DESIGNATION IS THE 12TH POSITION OF UNIT PRODUCT NUMBER.
- ALL DIMENSIONS ARE IN "MM" UNLESS NOTED.

NOTE: ALLOW 533.4 FROM FRONT FOR SERVICE

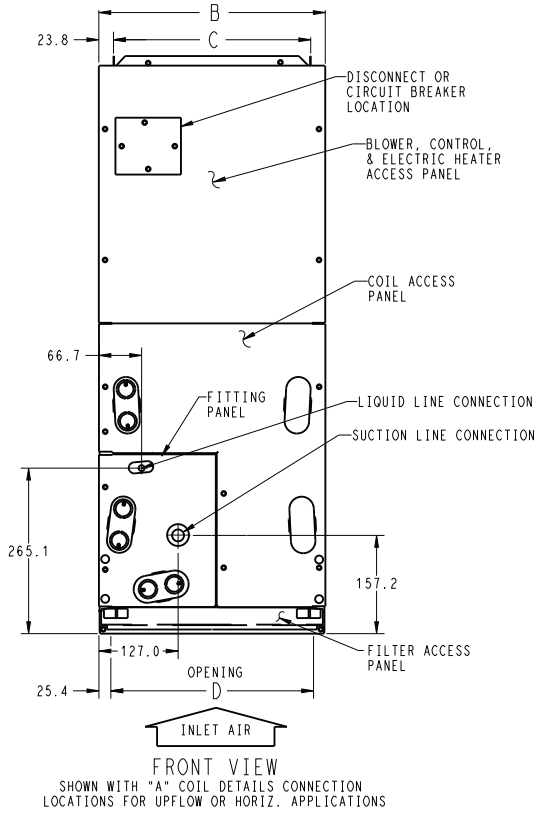
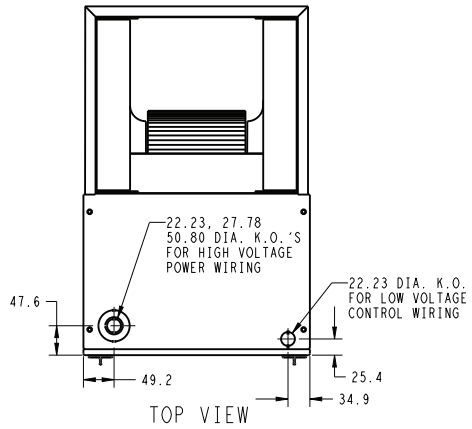

UNIT CONNECTION SIZES

SUCTION: 18 & 24 - 15.88 I.D. SWEAT
30 & 36 - 19.05 I.D. SWEAT
42 THRU 60 - 22.23 I.D. SWEAT
LIQUID: 9.53 I.D. SWEAT
CONDENSATE: 19.0 FPT

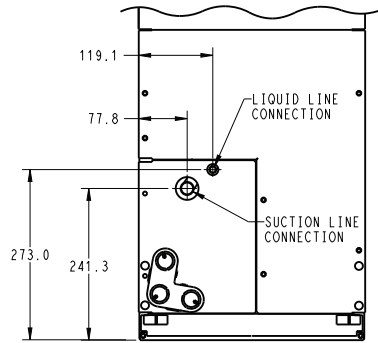

SLOPE COIL DETAILS
CONNECTION LOCATIONS SHOWN FOR UPFLOW OR HORIZ. LEFT APPLICATIONS

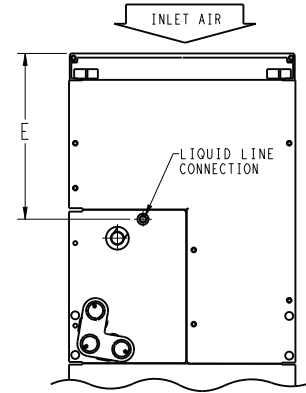

ACCESS PANEL CONFIG. FOR SLOPE COILS DOWNFLOW OR HORIZ. RIGHT APPLICATIONS AND "A" COILS DOWNFLOW APPLICATIONS

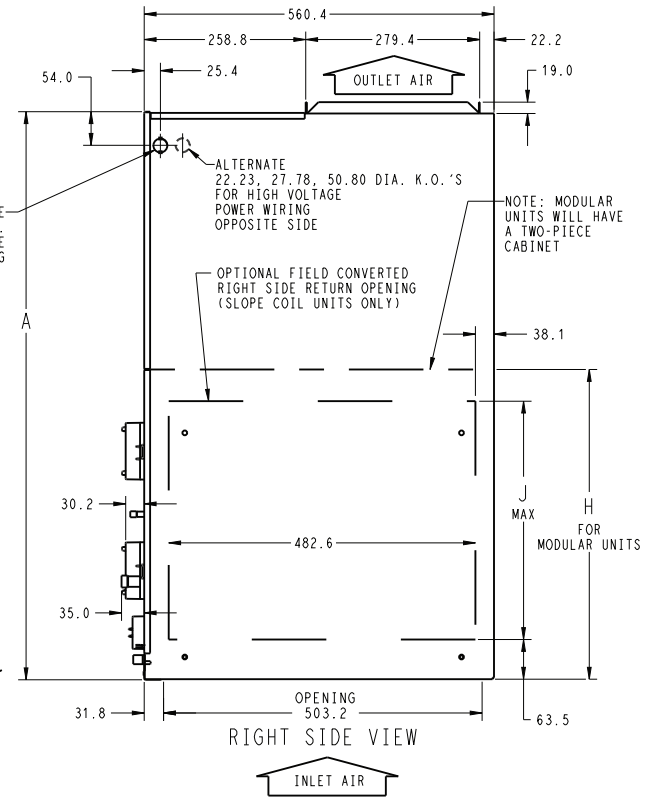

RIGHT SIDE VIEW

Fig. 3 – FEM4X (Metric)

SLOPE COIL

NOTES:

1. CONDENSATE PAN DRAIN CAPS NOT SHOWN FOR CLARITY.
2. ALL DIMENSIONS ARE IN "MM" UNLESS NOTED.

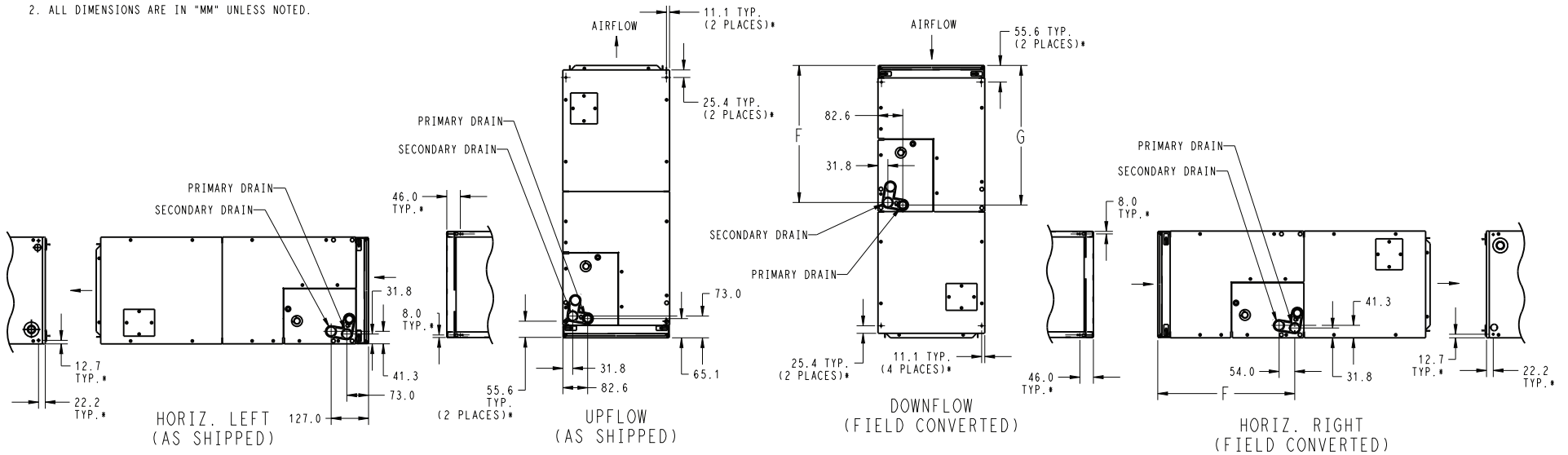

* HORIZONTAL MOUNT LOCATIONS - DIMPLES PROVIDED IN TOP PANEL, AND BACK OF CABINET. IN CABINET BOTTOM, HOLES PROVIDED 3.45 DIA. HORIZONTAL HANGING HARDWARE TO BE FIELD SUPPLIED.

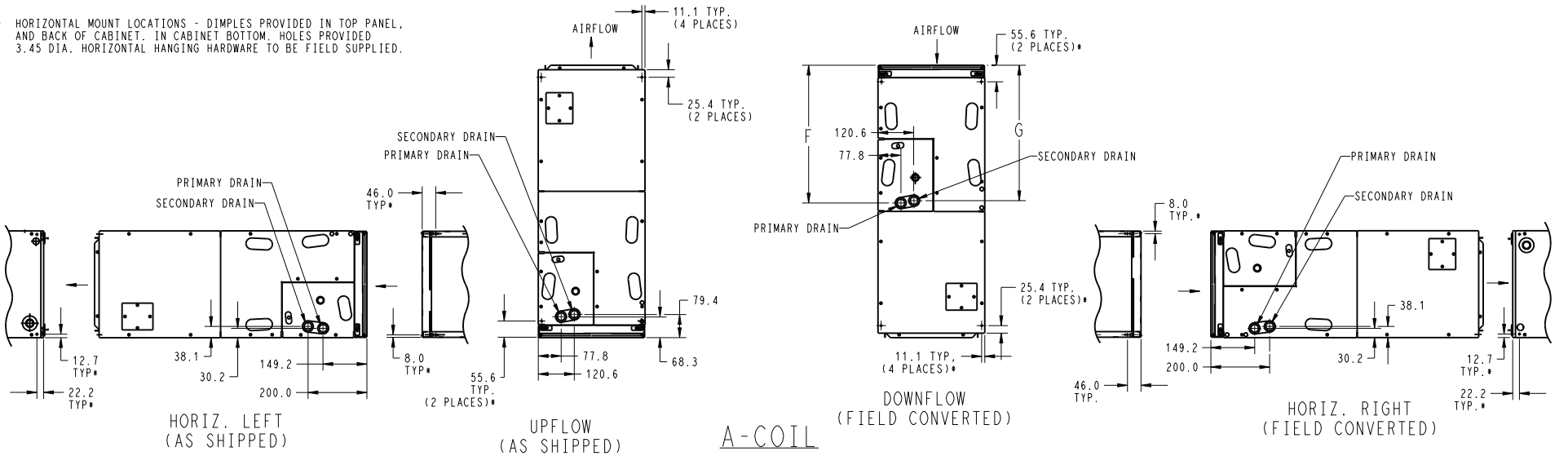

Fig. 4 – FEM4X Slope Coil (Metric)

A200373

DIMENSIONAL DATA (refer to drawings)														
Unit Size	Size (tons)	Dimensions inches (English)											Coil Type	Ship. WT lbs.
		A	B	C	D	E	F	G	H	J	Suct.	Liquid		
1800B	1-1/2	42-11/16	14-5/16	12-7/16	12-5/16	10-7/16	18-1/8	18-5/8	—	12	5/8	3/8	Slope	112
2400C	2	49-5/8	17-5/8	15-3/4	15-5/8	15-3/8	23-1/8	23-5/8	—	17	3/4	3/8	Slope	122
3000B	2-1/2	49-5/8	17-5/8	15-3/4	15-5/8	15-3/8	23-1/8	23-5/8	—	17	3/4	3/8	Slope	122
3600B	3	49-5/8	17-5/8	15-3/4	15-5/8	15-3/8	23-1/8	23-5/8	—	17	3/4	3/8	Slope	122
4200B	3-1/2	49-5/8	21-1/8	19-1/4	19-1/8	15-11/16	23-7/16	23-1/8	—	—	7/8	3/8	"A"	157
4800B	4	49-5/8	21-1/8	19-1/4	19-1/8	15-11/16	23-7/16	23-1/8	—	—	7/8	3/8	"A"	157
6000B	5	53-7/16	21-1/8	19-1/4	19-1/8	19-1/2	27-1/4	26-15/16	28-5/16	—	7/8	3/8	"A"	175

Unit Size	Size (tons)	Dimensions mm (SI Metric)											Coil Type	Ship. WT kg
		A	B	C	D	E	F	G	H	J	Suct.	Liquid		
1800B	1-1/2	1084	364	316	313	265	460	473	—	305	16	10	Slope	51
2400C	2	1261	448	400	397	391	587	600	—	432	19	10	Slope	55
3000B	2-1/2	1261	448	400	397	391	587	600	—	432	19	10	Slope	55
3600B	3	1261	448	400	397	391	587	600	—	432	19	10	Slope	55
4200B	3-1/2	1261	537	489	486	399	595	587	—	—	22	10	"A"	71
4800B	4	1261	537	489	486	399	595	587	—	—	22	10	"A"	71
6000B	5	1357	537	489	486	495	692	684	719	—	22	10	"A"	79

REQUIRED CLEARANCES - ALL MODELS inches (mm)		
No Heaters	All Sides	0
	From Supply Duct	0
With Heaters	All Sides	0
	From First 3 feet of Supply Duct to Combustibles	1 (25)
	From Supply Duct to Combustibles after 3 feet	0

PHYSICAL DATA							
	Size						
	1800B	2400C	3000B	3600B	4200B	4800B	6000B
Blower Data							
CFM (L/s) nominal	600 (283)	800 (378)	1000 (472)	1200 (566)	1400 (661)	1600 (755)	1750 (826)
Motor Type	ECM 5-speed						
HP	1/3	1/3	1/3	1/2	1/2	3/4	3/4
Filter Data (washable, available as accessory)							
	13 x 21-1/2 (330 x 546)	16-3/8 x 21-1/2 (416 x 546)			19-7/8 x 21-1/2 (505 x 546)		
Coil Data - Face Area ft² (m²)							
	2.23 (0.21)	2.97 (0.28)	2.97 (0.28)	2.97 (0.28)	4.45 (0.41)	4.45 (0.41)	5.93 (0.55)
Refrigerant Line Connections (sweat)							
Liquid inch (mm)	3/8 (10)						
Suction inch (mm)	5/8 (16)	5/8 (16)	3/4 (19)	3/4 (19)	7/8 (22)	7/8 (22)	7/8 (22)

ELECTRICAL DATA, FAN COIL ONLY WITHOUT ELECTRIC HEAT*			
Unit Size	208/230V, single phase, 60 Hz		
	Motor Full Load Amps (FLA)	Minimum Circuit Ampacity (MCA)	Maximum Fuse/Ckt Bkr Amps (Max OverCurrent Protection - MOCP)
1800B	2.8	3.5	15
2400C	2.8	3.5	15
3000B	2.8	3.5	15
3600B	4.1	5.1	15
4200B	4.1	5.1	15
4800B	6.0	7.5	15
6000B	6.0	7.5	15

*.SCCR (Short Circuit Current Rating) = 5kA rms, symmetrical, 230V

AIRFLOW PERFORMANCE - CFM at a given Speed and Static reading							
Model	Blower Speed	Total Static (inches water column)					
		0.10	0.20	0.30	0.40	0.50	0.60
FEM4X1800B	Tap 5	767	739	702	669	620	565
	Tap 4	614	569	534	486	436	398
	Tap 3	701	660	616	581	537	499
	Tap 2	614	569	534	486	436	398
	Tap 1	410	350	304	261	228	203
FEM4X2400C	Tap 5	969	936	892	835	763	676
	Tap 4	826	795	766	743	706	660
	Tap 3	826	795	766	743	706	660
	Tap 2	701	660	616	581	537	499
	Tap 1	617	592	552	507	472	420
FEM4X3000B	Tap 5	1108	1090	1065	1034	1009	974
	Tap 4	1026	1000	969	938	899	865
	Tap 3	1026	1000	969	938	899	865
	Tap 2	909	873	842	799	762	724
	Tap 1	825	795	757	722	674	634
FEM4X3600B	Tap 5	1301	1276	1245	1218	1176	1121
	Tap 4	1227	1191	1169	1143	1105	1074
	Tap 3	1227	1191	1169	1143	1105	1074
	Tap 2	1087	1062	1030	1001	966	930
	Tap 1	1026	1000	969	938	899	865
FEM4X4200B	Tap 5	1560	1544	1507	1464	1424	1358
	Tap 4	1419	1397	1358	1320	1279	1239
	Tap 3	1419	1397	1358	1320	1279	1239
	Tap 2	1249	1220	1184	1142	1093	1052
	Tap 1	1242	1205	1158	1110	1069	1026
FEM4X4800B	Tap 5	1743	1712	1679	1642	1610	1574
	Tap 4	1669	1634	1599	1564	1531	1499
	Tap 3	1669	1634	1599	1564	1531	1499
	Tap 2	1452	1413	1377	1339	1308	1271
	Tap 1	1300	1256	1221	1182	1142	1101
FEM4X6000B	Tap 5	1897	1867	1836	1808	1774	1736
	Tap 4	1817	1785	1757	1724	1693	1655
	Tap 3	1817	1785	1757	1724	1693	1655
	Tap 2	1657	1621	1589	1557	1518	1474
	Tap 1	1443	1412	1377	1332	1286	1243

■ - Airflow outside 450 cfm/ton.

Notes:

- Airflow based upon dry coil at 230v with factory-approved filter and electric heater (2 element heater sizes 1800 through 3600, 3 element heater sizes 4200 through 6000). Airflow at 208 volts is approximately the same as 230 volts because the ECM motor is a constant torque motor. The torque doesn't drop off at the speeds the motor operates.

- To avoid potential for condensate blowing out of drain pan prior to making drain trap: Return static pressure must be less than 0.40 in. wc. Horizontal applications of 4200 - 6000 sizes must have supply static greater than 0.20 in. wc.
- Airflow above 400 cfm/ton on 4800-6000 size could result in condensate blowing off coil or splashing out of drain pan.

STATIC PRESSURE CORRECTION from Dry to Wet Coil (inches of water column)																
Unit Size	CFM															
	500	600	700	800	900	1000	1100	1200	1300	1400	1500	1600	1700	1800	1900	2000
1800B	0.034	0.049	0.063	—	—	—	—	—	—	—	—	—	—	—	—	—
2400C	—	0.049	0.063	0.076	0.089	—	—	—	—	—	—	—	—	—	—	—
3000B	—	—	—	0.049	0.059	0.070	0.080	—	—	—	—	—	—	—	—	—
3600B	—	—	—	—	—	0.070	0.080	0.090	0.099	—	—	—	—	—	—	—
4200B	—	—	—	—	—	—	—	0.049	0.056	0.063	0.070	—	—	—	—	—
4800B	—	—	—	—	—	—	—	—	—	0.063	0.070	0.076	0.083	0.090	—	—
6000B	—	—	—	—	—	—	—	—	—	—	—	0.049	0.054	0.059	0.065	0.070

MINIMUM CFM when using Electric Heat										
Unit Size	Heater kW									
	3	5	8	9	10	15	18	20	24	30
1800B	525	525	525	—	600	—	—	—	—	—
2400C	700	700	700	—	700	775	—	—	—	—
3000B	—	875	875	—	875	875	—	1060	—	—
3600B	—	1050	970	970	970	920	—	1040	—	—
4200B	—	—	1225	1225	1225	1225	1225	1225	—	—
4800B	—	—	1400	1400	1400	1400	1400	1400	1400	1400
6000B	-	-	1750	1750	1750	1750	1750	1750	1750	1750

Note: Speed Tap 4 (white wire) is used for electric heat only. White wire must remain on tap 4.

STATIC PRESSURE CORRECTION for Electric Heaters (inches of water column)						
Airflow performance chart was developed using fan coils with 10 kW electric heater (2 elements) in the 1800 - 3600 model sizes, and 15 kW electric heaters (3 elements) in the 4200 - 4800 model sizes.						
When using a different number of heater elements, adjust the static pressure numbers by adding or subtracting the values in this table (for a given CFM, more electric heater elements create higher static pressure drop).						
Unit Size	Heater kW					
	No Heater	3 or 5	8 or 10	9 or 15	20	18, 24, or 30
	Number of Heat Elements					
	0	1	2	3	4	6
1800B	+0.02	+0.01	0	-0.02	-0.04	-
2400C	+0.02	+0.01	0	-0.02	-0.04	-
3000B	+0.02	+0.01	0	-0.02	-0.04	-
3600B	+0.02	+0.01	0	-0.02	-0.04	-
4200B	+0.04	-	+0.02	0	-0.02	-0.10
4800B	+0.04	-	+0.02	0	-0.02	-0.10
6000B	+0.04	-	+0.02	0	-0.02	-0.10

ELECTRIC HEATER Electrical Data

Heater Model	Heater kW		PHASE	INTERNAL CIRCUIT PROTECTION	HEATER AMPS 208/230V			BRANCH CIRCUIT														
								Min Ampacity ★ 208/230V			Min Wire Size (AWG) 208/230V ¹			Min Gnd Wire Size 208/230V			Max Fuse/Ckt Brk Amps 208/230V			Max Wire Length 208/230V (Ft) ††		
	230V	208V			Single Circuit	Dual Circuit		Single Circuit	Dual Circuit		Single Circuit	Dual Circuit		Single Circuit	Dual Circuit		Single Circuit	Dual Circuit		Single Circuit	Dual Circuit	
						L1,L2	L3,L4		L1,L2	L3,L4		L1, L2	L3, L4		L1, L2	L3,L4		L1,L2	L3,L4		L1,L2	L3,L4
EHK05AKN*	5	3.8	1	None	18.1/20.0	—	—	26.0/28.4	—	—	10/10	—	—	10/10	—	—	30/30	—	—	66/66	—	—
EHK05AKN**	5	3.8	1	None	18.1/20.0	—	—	31.2/33.5	—	—	8/8	—	—	10/10	—	—	35/35	—	—	85/88	—	—
EHK05AKB*	5	3.8	1	Ckt Bkr	18.1/20.0	—	—	26.0/28.4	—	—	10/10	—	—	10/10	—	—	30/30	—	—	66/66	—	—
EHK05AKB**	5	3.8	1	Ckt Bkr	18.1/20.0	—	—	31.2/33.5	—	—	8/8	—	—	10/10	—	—	35/35	—	—	85/88	—	—
EHK07AKN	8	6.0	1	None	28.9/32.0	—	—	44.7/48.5	—	—	8/8	—	—	10/10	—	—	45/50	—	—	59/60	—	—
EHK07AKB	8	6.0	1	Ckt Bkr	28.9/32.0	—	—	44.7/48.5	—	—	8/8	—	—	10/10	—	—	45/50	—	—	59/60	—	—
EHK09AKCN†	9	6.8	1	None	32.8/36.0	—	—	49.5/53.5	—	—	8/6	—	—	10/10	—	—	50/60	—	—	54/87	—	—
	9	6.8	3	None	18.8/20.8	—	—	32.0/34.5	—	—	8/8	—	—	10/10	—	—	35/35	—	—	83/85	—	—
EHK10AKN	10	7.5	1	None	36.2/40.0	—	—	53.8/58.5	—	—	6/6	—	—	10/10	—	—	60/60	—	—	78/80	—	—
EHK10AKB	10	7.5	1	Ckt Bkr	36.2/40.0	—	—	53.8/58.5	—	—	6/6	—	—	10/10	—	—	60/60	—	—	78/80	—	—
EHK15AKF	15	11.3	1	Fuse	54.2/59.9	36.2/40.0	18.1/20.0	76.3/83.4	53.8/58.5	22.7/25.0	4/4	6/6	10/10	8/8	10/10	10/10	80/90	60/60	25/25	88/89	78/80	75/76
EHK15AKB	15	11.3	1	Ckt Bkr	—	36.2/40.0	18.1/20.0	—	53.8/58.5	22.7/25.0	—	6/6	10/10	—	10/10	10/10	—	60/60	25/25	—	78/80	75/76
EHK15AHN	15	11.3	3	None	31.3/34.6	—	—	47.7/51.8	—	—	8/6	—	—	10/10	—	—	50/60	—	—	56/90	—	—
EHK18AHN	18	13.5	3	None	37.6/41.5	—	—	55.5/60.4	—	—	6/6	—	—	10/8	—	—	60/70	—	—	76/77	—	—
EHK20AKF	20	15.0	1	Fuse	72.3/79.9	36.2/40.0	36.2/40.0	98.9/108.4	53.8/58.5	45.3/50.0	3/2	6/6	8/8	8/6	10/10	10/10	100/110	60/60	50/50	85/109	78/80	59/59
EHK20AKB	20	15.0	1	Ckt Bkr	—	36.2/40.0	36.2/40.0	—	53.8/58.5	45.3/50.0	—	6/6	8/8	—	10/10	10/10	—	60/60	50/50	—	78/80	59/59
EHK25AHCF‡	24	18.0	3	Fuse	50.1/55.4	—	—	71.2/77.8	—	—	4/4	—	—	8/8	—	—	80/80	—	—	94/95	—	—
	24	18.0	1	Fuse	86.7/95.5	—	—	116.9/127.9	—	—	1/1	—	—	6/6	—	—	125/150	—	—	115/116	—	—
EHK30AHCF‡	30	22.5	3	Fuse	62.6/69.2	—	—	86.8/95.0	—	—	3/3	—	—	8/8	—	—	90/100	—	—	97/98	—	—
	30	22.5	1	Fuse	109.0/120.0	—	—	144.8/158.5	—	—	0/00	—	—	6/6	—	—	150/175	—	—	117/150	—	—

FIELD MULTIPOINT WIRING OR 24 AND 30 kW SINGLE PHASE

Heater Model	Heater kW		PHASE	Heater Amps 208/230V			Minimum Circuit Ampacity 208/230V ★			Minimum Wire Size (AWG) 208/230V ‡			Min Gnd Wire Size 208/230V	Max Fuse/Ckt Brk Amps 208/230V			Max Wire Length 208/230V (FT) ††		
				L1, L2	L3, L4	L5, L6	L1, L2	L3, L4	L5, L6	L1, L2	L3, L4	L5, L6		L1, L2	L3, L4	L5, L6	L1, L2	L3, L4	L5, L6
	230V	208V		L1, L2	L3, L4	L5, L6	L1, L2	L3, L4	L5, L6	L1, L2	L3, L4	L5, L6		L1, L2	L3, L4	L5, L6	L1, L2	L3, L4	L5, L6
EHK25AHCF‡	24	18.0	1	28.9/32.0	28.9/32.0	28.9/32.0	44.7/48.5	36.2/40.0	36.2/40.0	8/8	8/8	8/8	10/10	45/50	40/40	40/40	59/60	73/73	73/73
EHK30AHCF‡	30	22.5	1	36.2/40.0	36.2/40.0	36.2/40.0	53.8/58.5	45.3/50.0	45.3/50.0	6/6	8/8	8/8	10/10	60/60	50/50	50/50	78/80	59/59	59/59

Notes:

¹ Copper wire must be used. If other than uncoated (non-plated), 75°C ambient, copper wire (solid wire for 10 AWG and smaller, stranded wire for larger than 10 AWG) is used, consult applicable tables of the National Electric Code (ANSI/NFPA 70)

* When used with Fan Coil model sizes 2400, 3600

** When used with Fan Coil model sizes 4200, 4800, 6000

★ Includes blower motor amps of largest Fan Coil used with heater

† Supplied as single phase, field convertible to 3-phase

‡ Supplied as 3-phase, field convertible to single phase, single or multiple supply circuits

†† Length shown is as measured one way along wire path between unit and service panel for a voltage drop not to exceed 2%

Manufacturer reserves the right to change, at any time, specifications and designs without notice and without obligations.

ACCESSORIES		
Part Number	Description	Use with Model Sizes
EBAC01DSC	Disconnect Kit	Use with All single phase Heaters 5 kW thru 10 kW
EBAC01NCB	Downflow Base Kit	1800B
EBAC02NCB		2400C, 3000B, 3600B
EBAC03NCB		4200B, 4800B, 6000B
EBAC01DFS	Bracket, Downflow Conversion Kit - Slope Coil	1800B, 2400C, 3000B, 3600B
EBAC02DFA	Bracket, Downflow Conversion Kit - "A" Coil	4200B, 4800B, 6000B
EBAC01SPK	Single Point Wiring Kit	Only for use with 15 kW & 20 kW fused heaters
Square D® part # QOU14100JBAF *	Single Point Wiring Kit - Square D® Jumper Bar Assembly	Only for use with EHK15AKB and EHK20AKB breaker heaters
EBAC01FKS	Filter Kit (washable, box of 12)	1800B
EBAC01FKM		2400C, 3000B, 3600B
EBAC01FKL		4200B, 4800B, 6000B
NASA00101FR	Standard Filter Rack (12 x 20 x 1 filter required)	1800B
NASA00201FR	Standard Filter Rack (16 x 20 x 1 filter required)	2400C, 3000B, 3600B
NASA00301FR	Standard Filter Rack (20 x 20 x 1 filter required)	4200B, 4800B, 6000B
EBAC01PLG	No Heat (Plug) Kit (box of 6)	Factory Installed
EBAC01CTK	PVC Condensate Trap Kit (box of 50)	ALL
EBAC01GSK	Horizontal Downflow Gasket Kit	ALL (required for horizontal right and downflow)
NAEB20101TX	TXV Kit, R-22, Aluminum Coils Only	1800BL, 2400CL, 3600BL, 4200BL
NAEB20201TX		4800BL
NAEB20301TX		6000BL

* Square D part number given for reference only. Check with local Square D supplier.

ELECTRIC HEATERS		
Part Number	Description	Use with Model Sizes
EHK05AKN	5 kW, single phase, no internal circuit protection	ALL
EHK05AKB	5 kW, single phase, with circuit breakers	ALL
EHK07AKN	8 kW, single phase, no internal circuit protection	ALL
EHK07AKB	8 kW, single phase, with circuit breakers	ALL
EHK09AKCN	9 kW, supplied as single phase, field convertible to 3-phase, no internal circuit protection	3600B, 4200B, 4800B, 6000B
EHK10AKN	10 kW, single phase, no internal circuit protection	ALL
EHK10AKB	10 kW, single phase, with circuit breakers	ALL
EHK15AKF	15 kW, single phase, with fuses	2400C, 3000B, 3600B, 4200B, 4800B, 6000B
EHK15AKB	15 kW, single phase, with circuit breakers	2400C, 3000B, 3600B, 4200B, 4800B, 6000B
EHK15AHN	15 kW, 3-phase, no internal circuit protection	3600B, 4200B, 4800B, 6000B
EHK18AHN	18 kW, 3-phase, no internal circuit protection	4200B, 4800B, 6000B
EHK20AKF	20 kW, single phase, with fuses	3000B, 3600B, 4200B, 4800B, 6000B
EHK20AKB	20 kW, single phase, with circuit breakers	3600B, 4200B, 4800B, 6000B
EHK25AHCF	24 kW, supplied as 3-phase, field convertible to single phase, with fuses	4800B, 6000B
EHK30AHCF	30 kW, supplied as 3-phase, field convertible to single phase, with fuses	4800B, 6000B