



# INNOVATIVE STRUCTURAL TECHNOLOGIES





HIGH-SPEED CONSTRUCTION,  
REDUCED COST, LONGER LIFE,  
REDUCED ENVIRONMENTAL FOOTPRINT



# The Next Normal in Construction

How disruption is reshaping the world's largest ecosystem

Mc Kinsey – June 2020

Change in Market Characteristics	Future Industry Dynamics	Emerging Disruptions
<p><b>Customer demand</b></p> <ul style="list-style-type: none"> <li>Persistent cost pressure from tight public budgets and housing-affordability concerns</li> <li>Increasing need for adaptable structures</li> <li>Increasing owner and customer sophistication</li> <li>Evolving customer needs and greater focus on total cost of ownership</li> <li>Increasing complexity of projects</li> <li>Higher demand for simplified and digital interactions</li> <li>Increasing sustainability requirements and demands for safety performance</li> </ul>	<p><b>Product-based approach</b></p>	 <p><b>FSC Industrialization</b></p> <p>New production technology-enabling industrialization and shift toward off-site production</p>
<p><b>Construction inputs and characteristics</b></p> <ul style="list-style-type: none"> <li>Persistent scarcity of skilled labor</li> <li>Changing logistics equation resulting from new materials and modules</li> </ul>	<p><b>Specialization</b></p>	 <p><b>FSC New materials</b></p> <p>New material technology-new lighter-weight materials enabling improved logistics</p>
<p><b>Market rules and regulations</b></p> <ul style="list-style-type: none"> <li>Stricter regulation on safety and sustainability</li> <li>Changing regulations and incentives for modern methods of construction, enabling more standardization</li> </ul>	<p><b>Value-chain control and integration with industrial-grade supply chains</b></p> <p><b>Consolidation</b></p> <p><b>Customer-centricity and branding</b></p> <p><b>Investment in technology and facilities</b></p> <p><b>Investment in human resources</b></p> <p><b>Internationalization</b></p> <p><b>Sustainability</b></p>	 <p><b>FSC New entrants</b></p> <p>New breed of players-disrupting current business models</p>  <p><b>Digitalization of products and processes</b></p> <p>Digitalization of processes and products and shift toward more data-driven decision making-digital will impact:</p> <ul style="list-style-type: none"> <li>Operations-smart buildings and infrastructure</li> <li>Design-BIM,BIM objects</li> <li>Construction and production-BIM, project management, industry 4.0</li> <li>Channels-digital sales channels and distribution/logistics</li> </ul>

# New Game-Changing Products that exceed the limits set by current technologies

## Underground Infrastructure

- NEW ULTRA-THIN CONCRETE PIPES
- CONCRETE PIPES 2.0
- HYPERLOOP VACUUM TUBE

## Buildings and Enclosures

- FLEXIBLE PAVERS
- MANHOLE COVERS
- WALLS AND INSULATED CLADDING SYSTEMS

## Railway

- NEW ULTRA-THIN CONCRETE PIPES
- CONCRETE PIPES 2.0
- HYPERLOOP VACUUM TUBE

## Structural Precast

- FLEXIBLE PAVERS
- MANHOLE COVERS
- WALLS AND INSULATED CLADDING SYSTEMS



## The FLEXSTREN Technology

**Fiber Rovings**

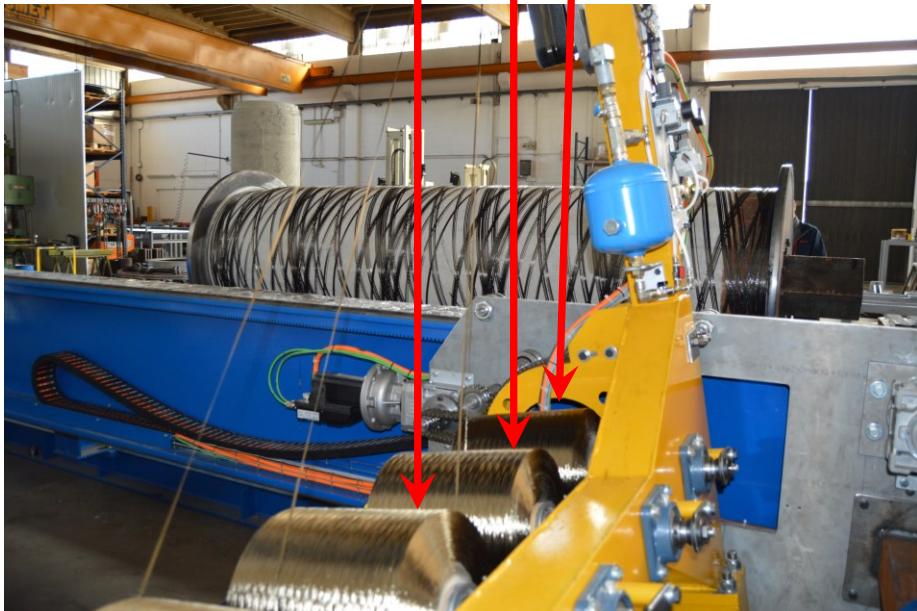

**Wrapping in tension with the fiber impregnated with resin**

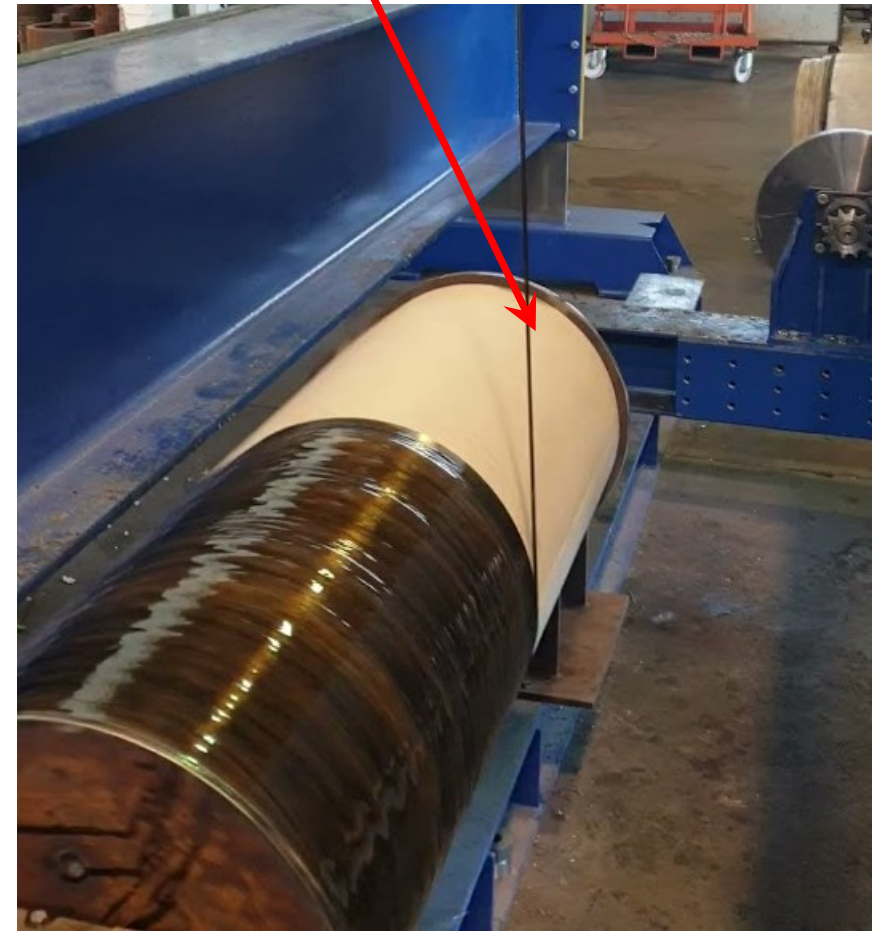

# Why is FLEXSTREN so Disruptive?

- FLEXSTREN enables the elimination of reinforcing steel from concrete products
- FLEXSTREN enables neutral PH cement in structural applications
- FLEXSTREN enables the production of new products and structures that cannot be produced with current technologies
- FLEXSTREN enables concrete structures with structural ductility similar to steel structure
- FLEXSTREN will allow for a giant leap in the Industrialization of the Construction industry

# Some Applications



## Current Pipes limits

Concrete Reinforced



Plastic



Concrete Unreinforced



## FLEXSTREN Concrete Pipes

- **NEW ULTRA-THIN CONCRETE PIPES** allowing producers to return to the small diameter pipe market
- For the **CURRENT CONCRETE PIPES** cost and CO2 footprint savings, functionality is improved



# New FLEXSTREN Ultra-Thin Concrete Pipes, from 150 mm ID (6")

To bring back concrete pipes in the small diameter sizes

They are a new concept Concrete Pipe with a thickness 1/20 - 1/25 of the ID, and are superior to any other type of Pipe in terms of cost, sustainability and functionality: they can be laid on aggressive soil, are capable of pressure application more than 3.5 Bars, exhibit semirigid behavior, less expensive bedding and back filling vs fiber / plastic pipes



[Click on the image to open a Youtube Video](#)

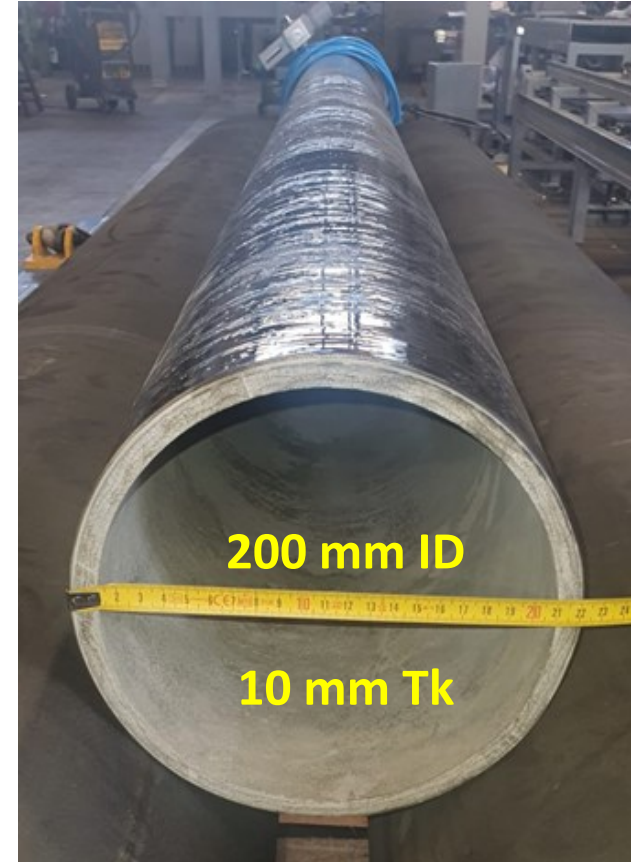



## C76 Reinforced Concrete Pipe

450 mm ID – 63 mm Thickness  
Class III – Wall B



## Concrete Pipe wrapped with FLEXSTREN (no steel reinforcing)

450 mm ID – 22 mm Thickness

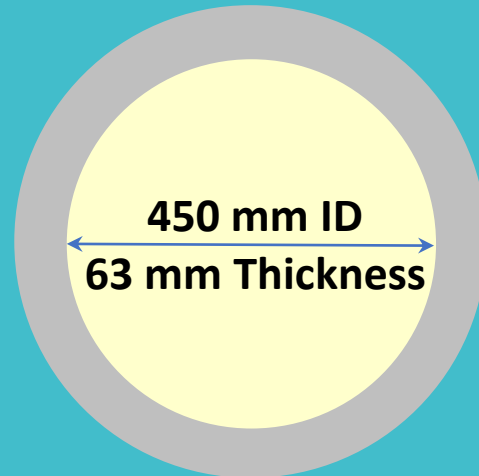

Raw material CO2 Footprint Saving 68%  
Raw Material Cost Saving 49

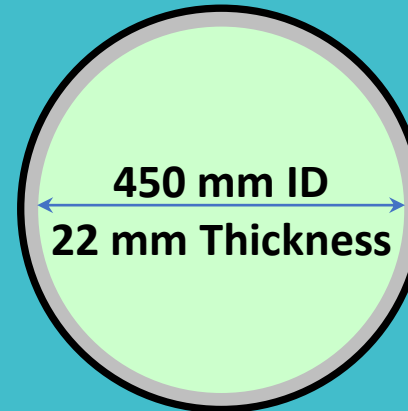



## Current Concrete Pipes – replacement of the steel reinforcing with the FLEXSTREN wrapping



- **COST AND CO2 FOOTPRINT SAVINGS**
- **CORROSION FREE**
- **PRESSURE CAPABILITIES MORE THAN 3.5 BAR**
- **LAI D ON AGGRESSIVE SOILS**
- **JACKING PIPES WITH ADDITIONAL AXIAL CAPACITY**
- **THE WRAPPING IS ALSO APPLICABLE TO NON-REINFORCED PIPES**

# FLEXSTREN Vacuum Tube for the Hyperloop Train System

- It is the most suitable solution for cost, weight, sustainability and functionality.
- It is transparent to electromagnetic radiation.

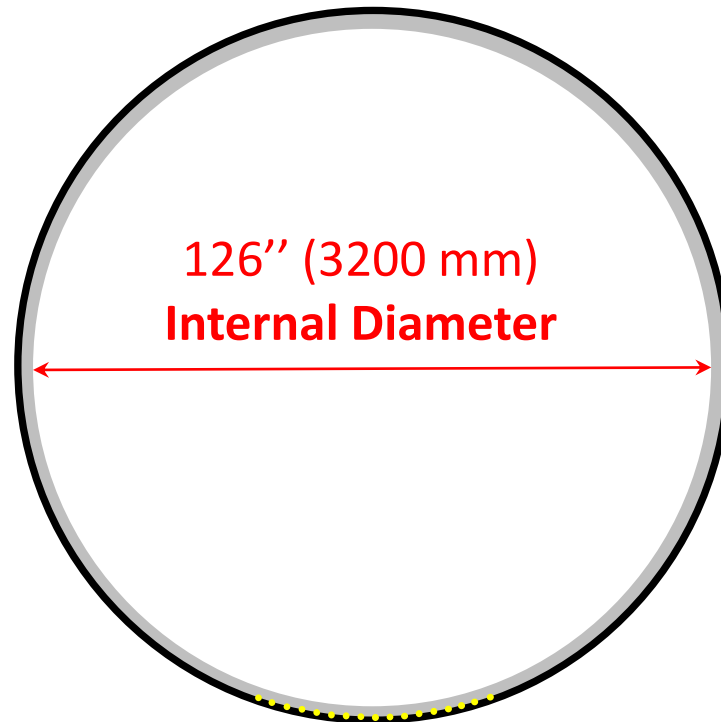

# FLEXSTREN

## DRYCAST RAILWAY SLEEPERS

### CORROSION FREE

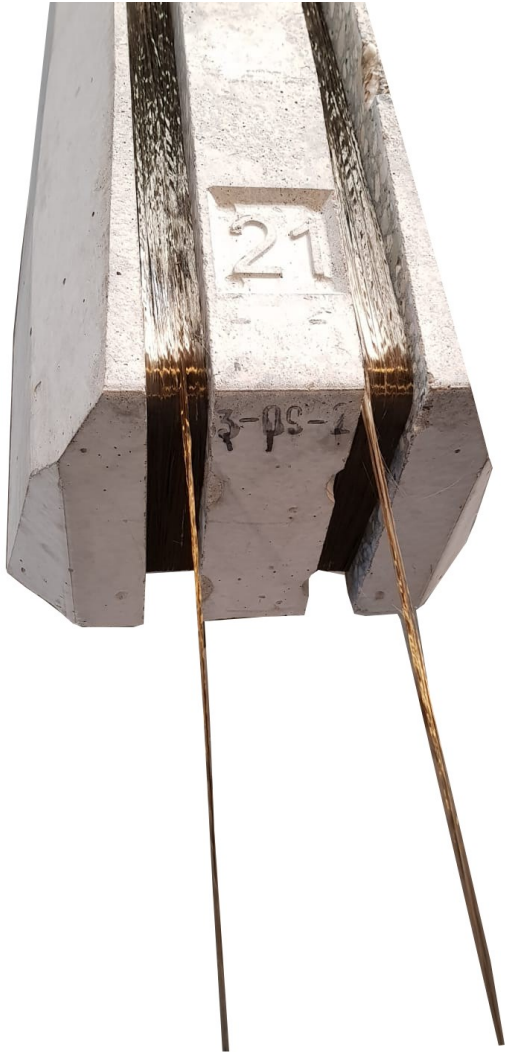

#### ADVANTAGES VS. TRADITIONAL CONCRETE SLEEPERS:

- Longer life cycle due to the elimination of steel reinforcing
- High productivity due to immediate demolding process, resistance to freeze-thaw cycles by the use of dry cast concrete, any cracking does not lead to failure, electrical conductivity free
- Reduced relaxation losses compared to steel reinforcement, it is easy to make low volumes of custom shapes, low cost sleepers
- Possibility to insert objects sensitive to deformations due to the passage of trains, which can generate energy, and transmit information
- The winding reinforcement can reduce vibrations when trains pass

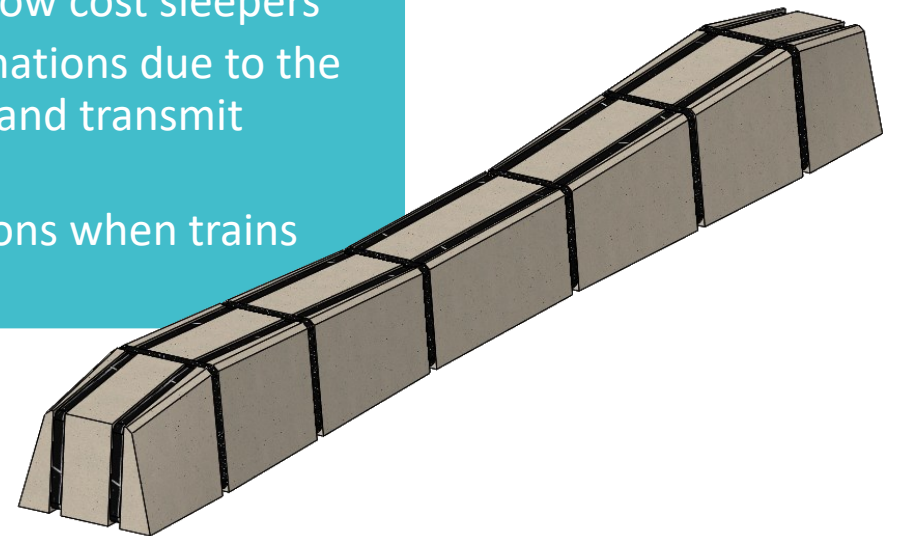

# FLEXSTREN

DRYCAST RAILWAY SLEEPERS  
CORROSION FREE

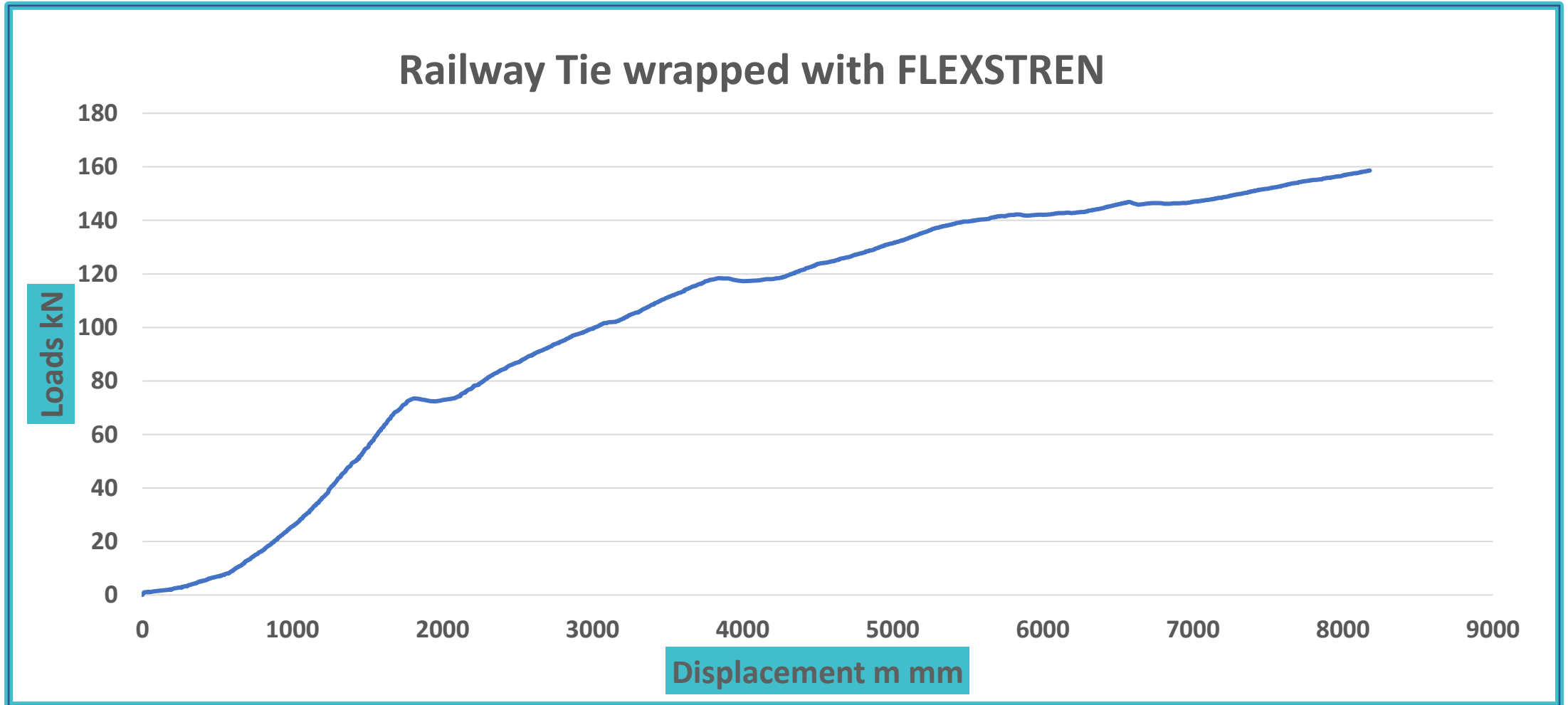

# FLEXSTREN

## Catenary Poles

*They are Catenary Poles produced with a concrete core which is then post compressed axially and circumferentially by wrapping a composite around the outside diameter*

### ADVANTAGES VS. GRP AND TRADITIONAL POLES:

- It has an initial cost lower than traditional poles
- It has a very low conductivity
- It has a lower environmental footprint than any other pole material
- It has a service life that will be equal or better than a GRP pole



# WRAPPED BLOCKS

for a fast Block Wall Construction / Offshore Wind Towers

**Regular**



**FLEXSTREN**



Key points are:

the flexural strength of the wrapped blocks

the way the blocks are glued together (next slide)



FLEXSTREN wrapping improves the flexural strength of each block

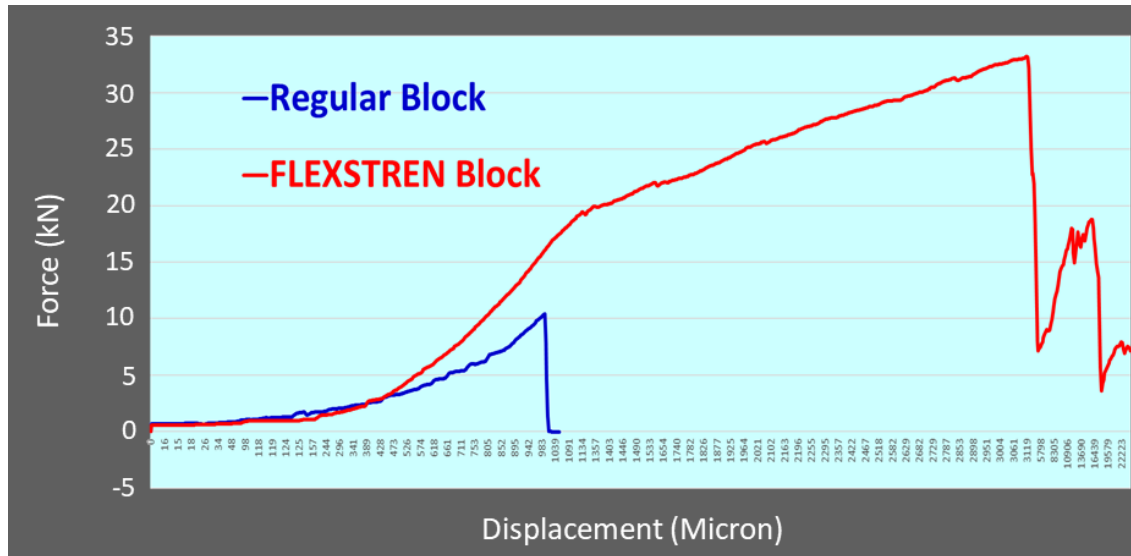

## WRAPPED BLOCKS

for a fast Block Wall Construction / Offshore Wind  
Towers

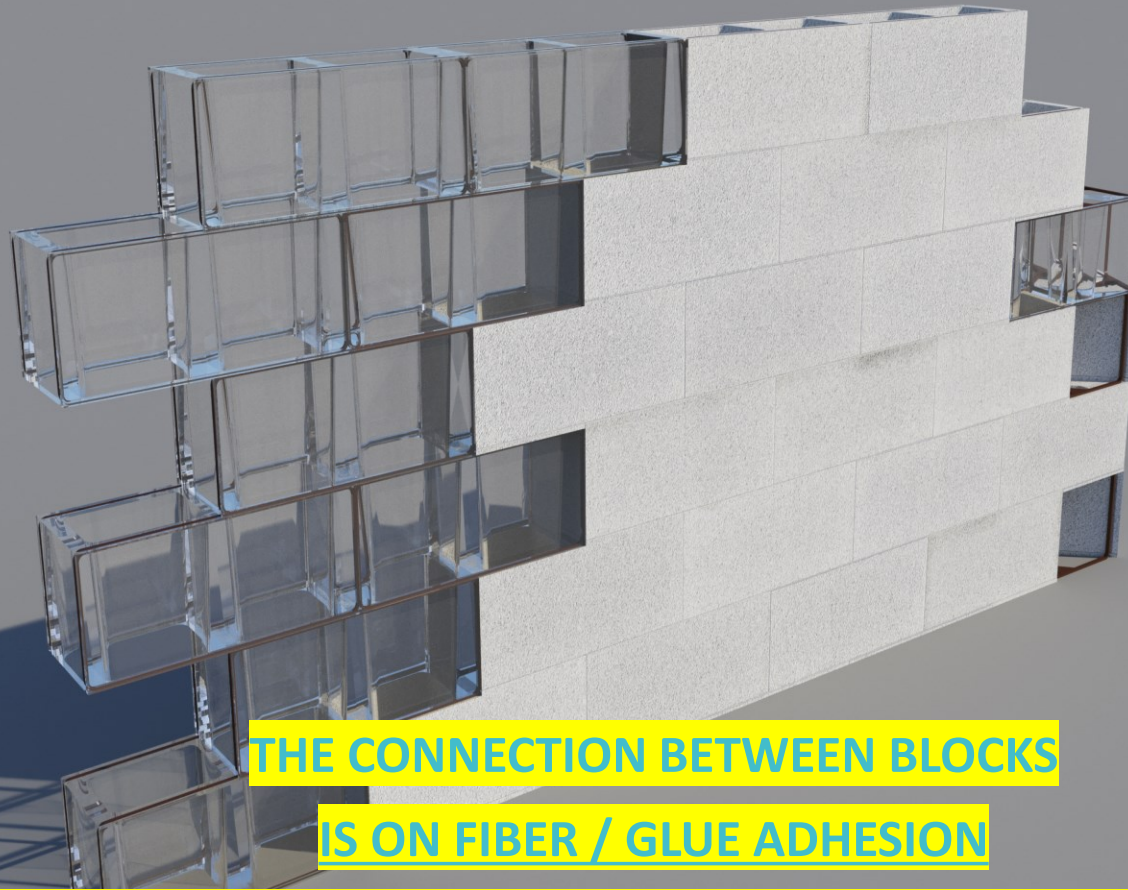

**THE CONNECTION BETWEEN BLOCKS**

**IS ON FIBER / GLUE ADHESION**

**and this completely changes the structural behavior of the wall**

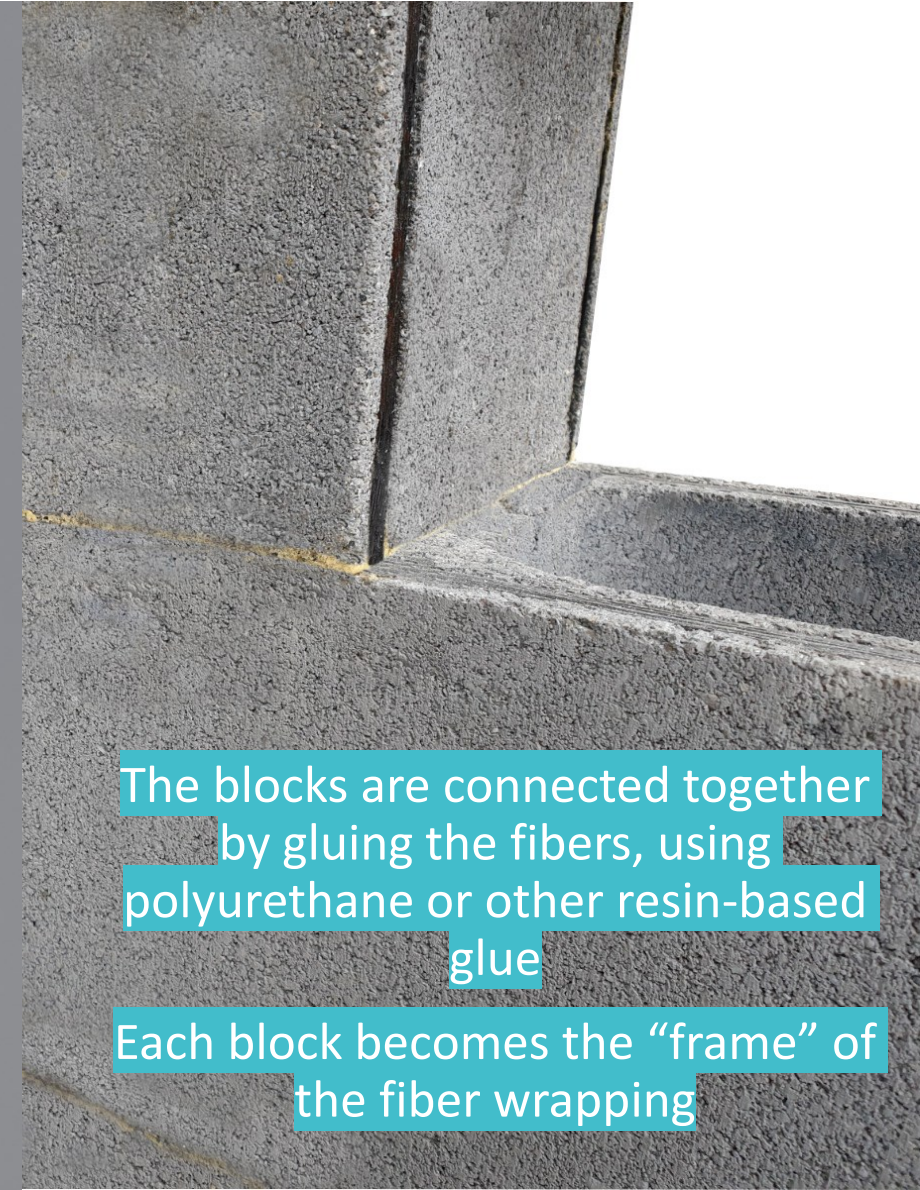

The blocks are connected together  
by gluing the fibers, using  
polyurethane or other resin-based  
glue

Each block becomes the “frame” of  
the fiber wrapping



The wall has a structural behavior much more ductile of the traditional block walls, that opens up new possibilities for structural applications

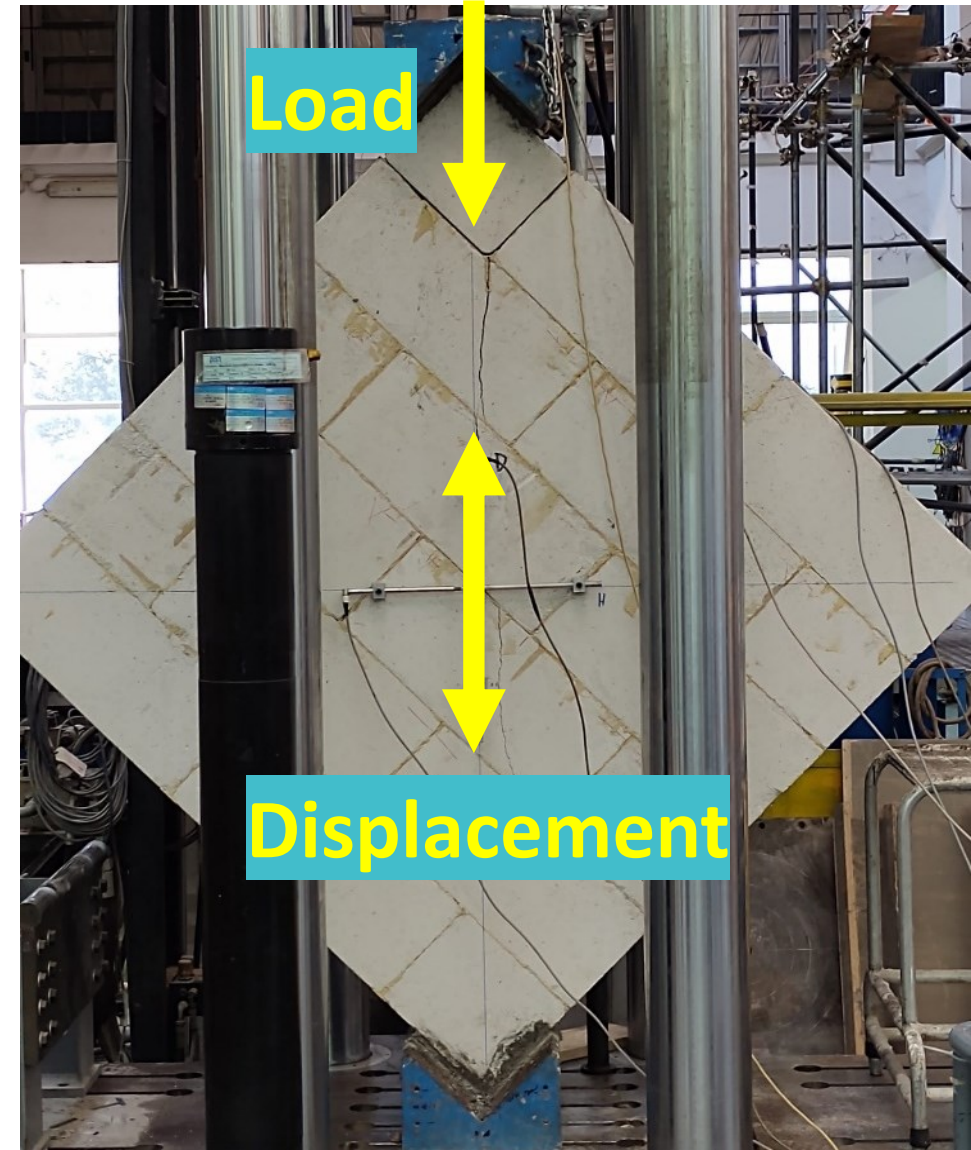
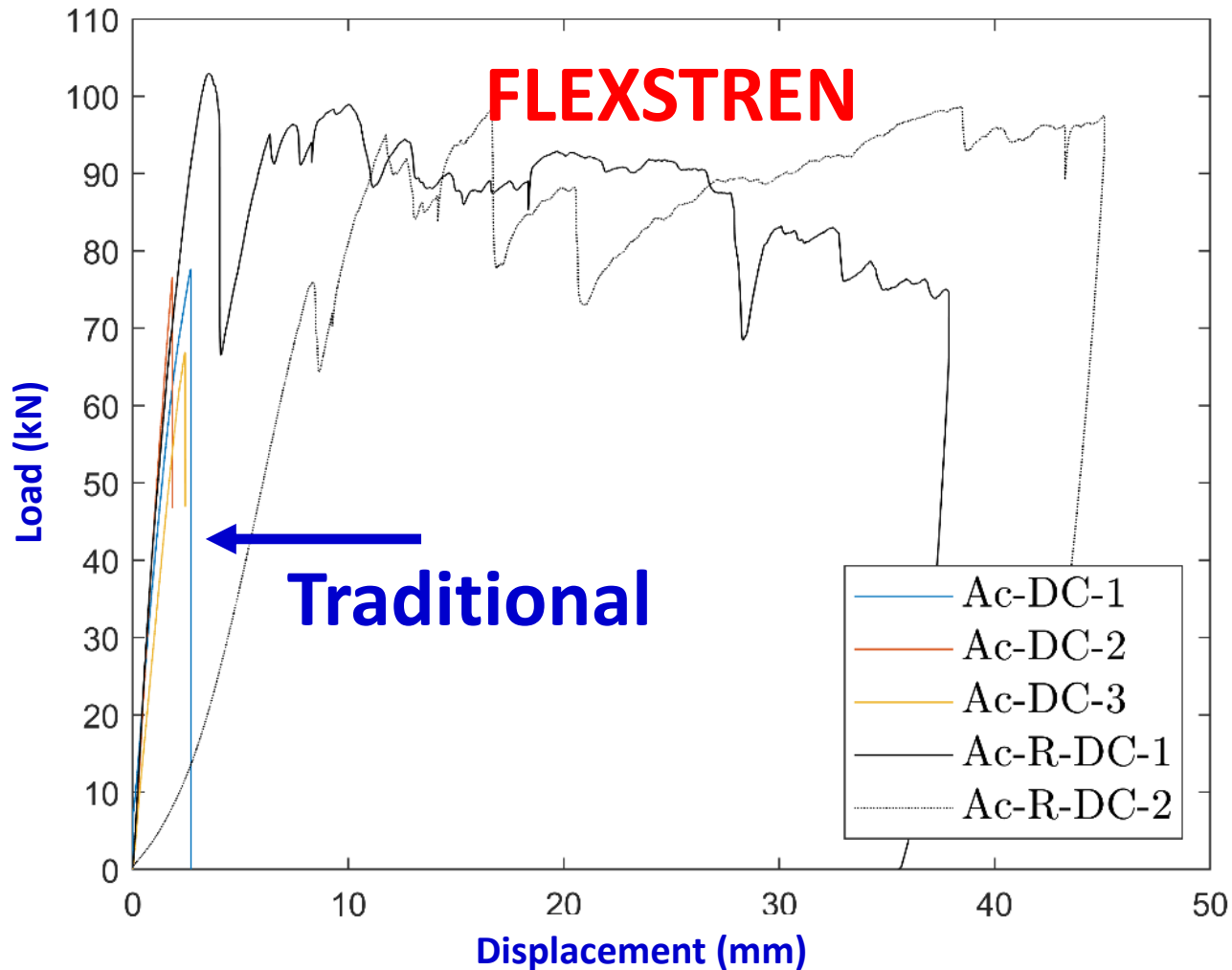

# WRAPPED BLOCKS

## Offshore Wind Towers

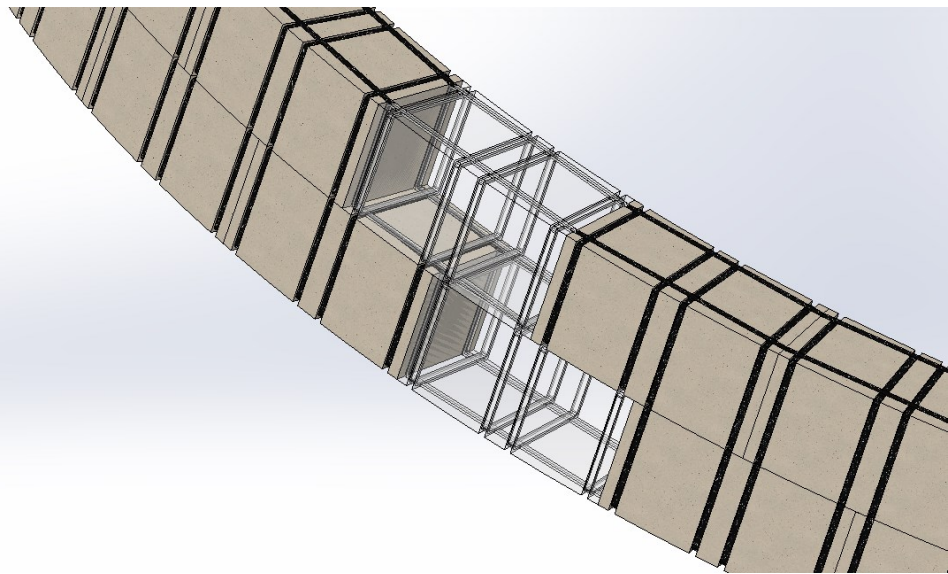
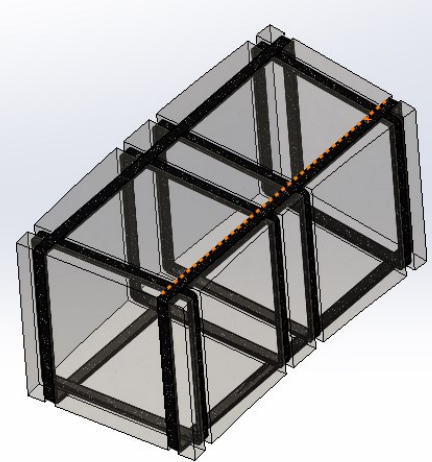
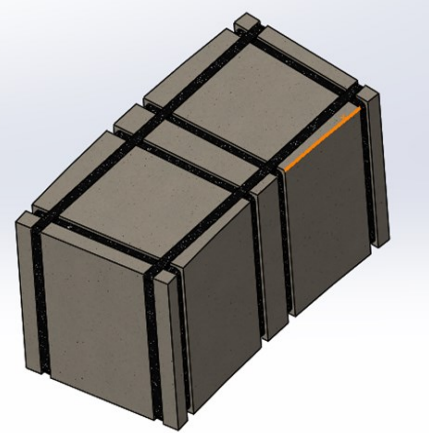
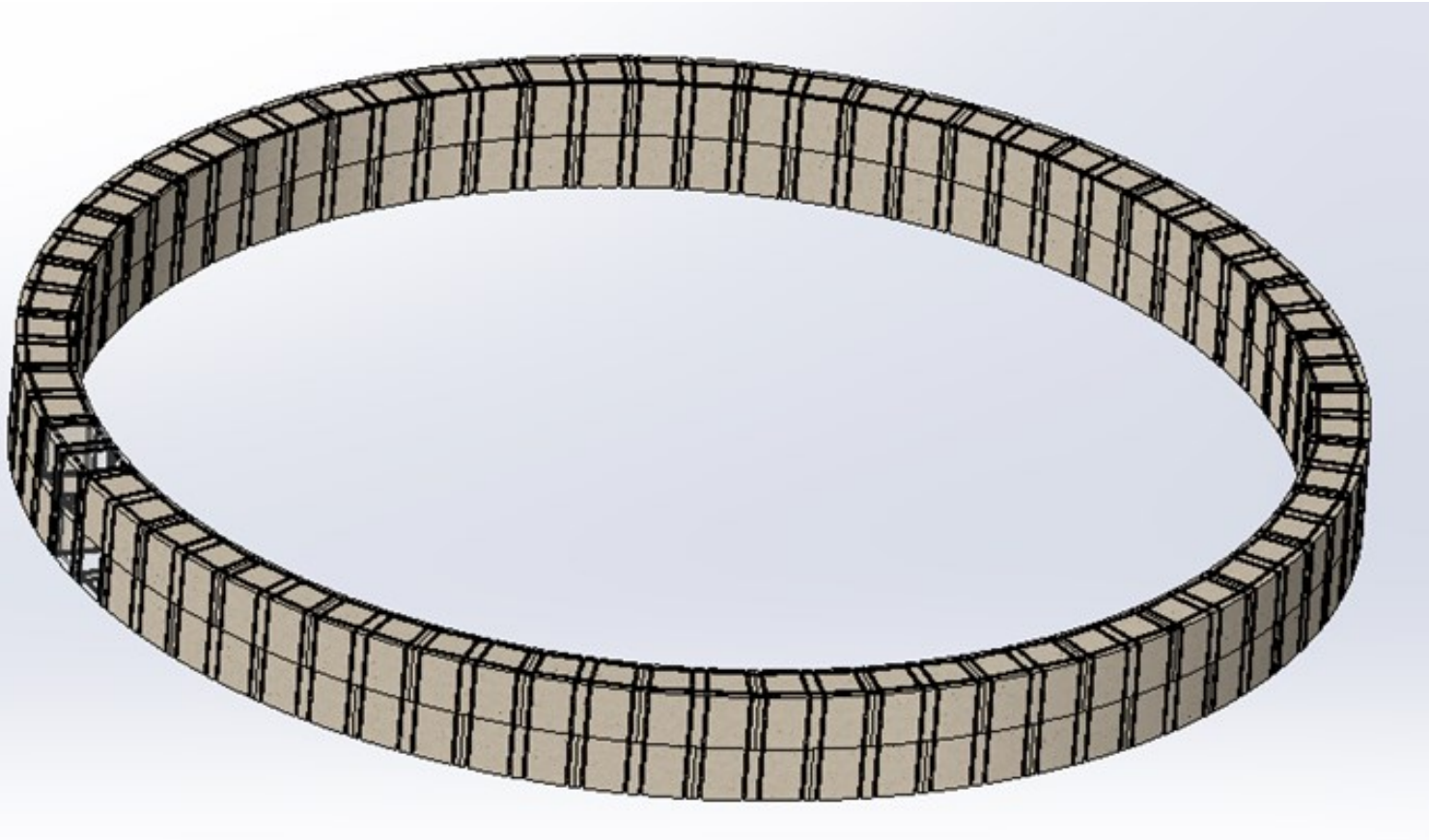

# WRAPPED BLOCKS

## Explosion Proof Bunkers

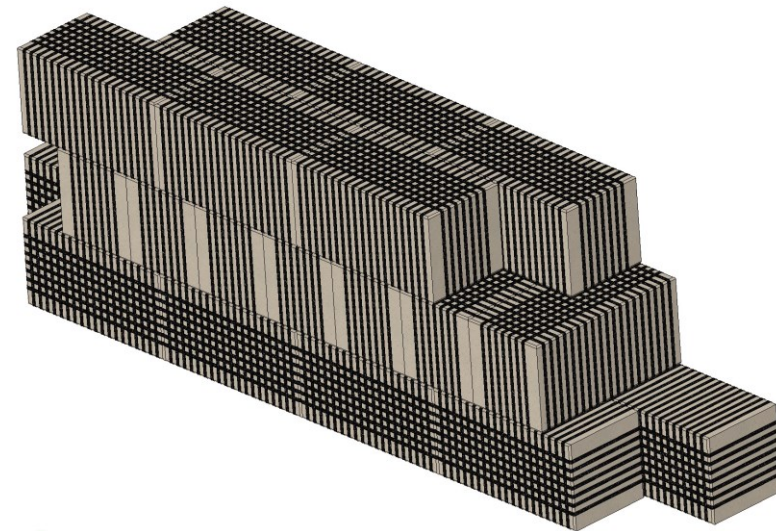
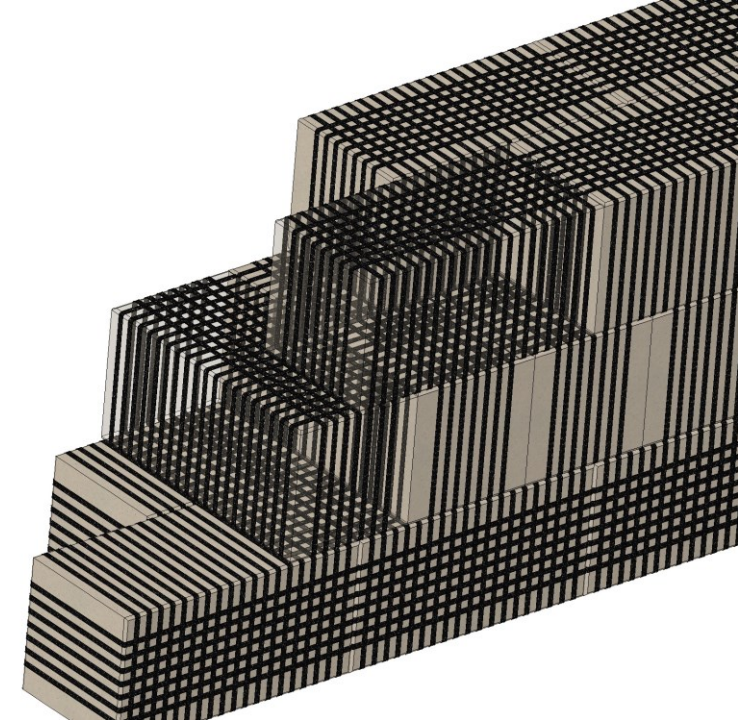
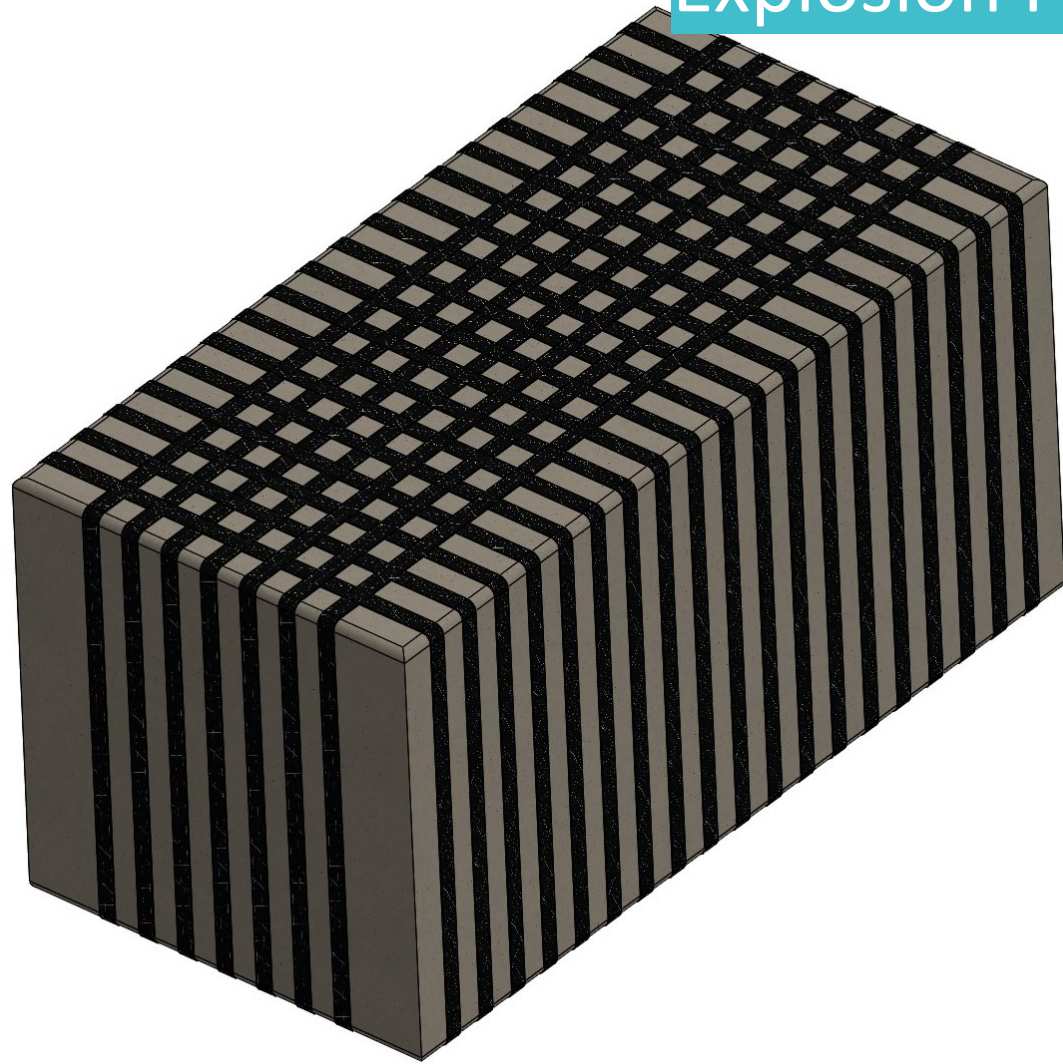



## FLEXSTREN provides FLEXURAL STRENGTH for PAVERS

Such “wrapped” pavers can deform a lot, crack in the tensioned sides but NO CRACK IS SHOWN AT THE TOP.

By reducing the load, the paver exhibits an elastic behavior and returns to its original shape.





## FLEXSTREN for Manhole Covers

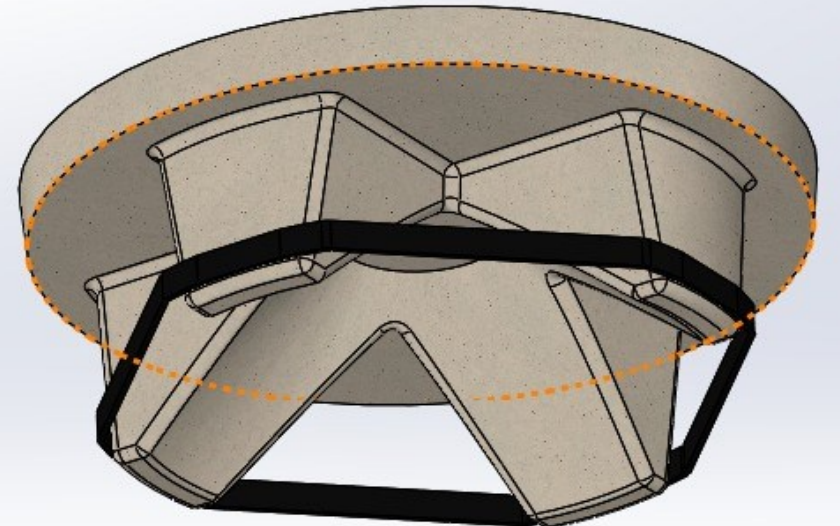
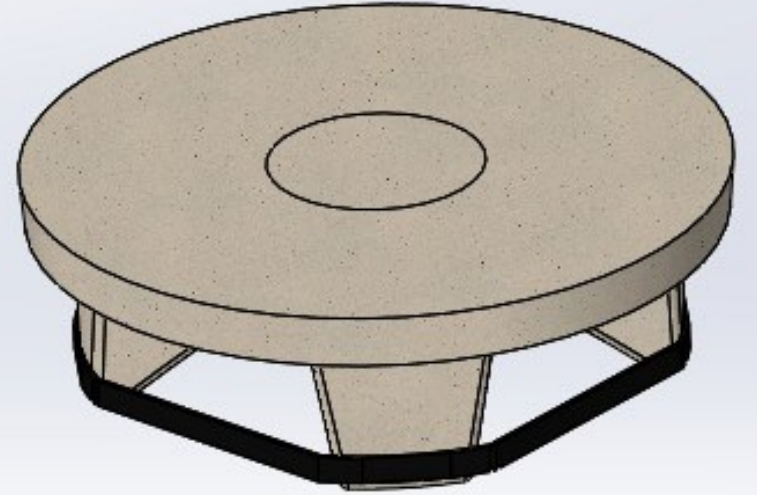

FLEXSTREN makes possible the assembly of innovative post compressed elements without the need for post tensioning wires running the length of the span.

The post compression by wrapping allows to have a strong mechanical connections between segments.

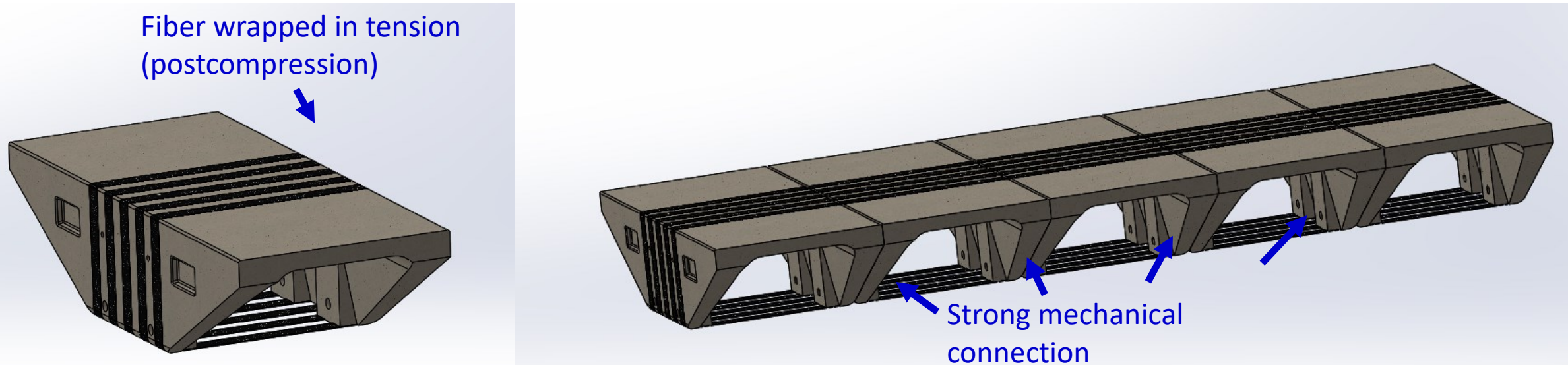

FLEXSTREN allows the construction of very high-performance structural frames with full moment connection created from highly standardized elements with completely dry installation, like that of the steel structures

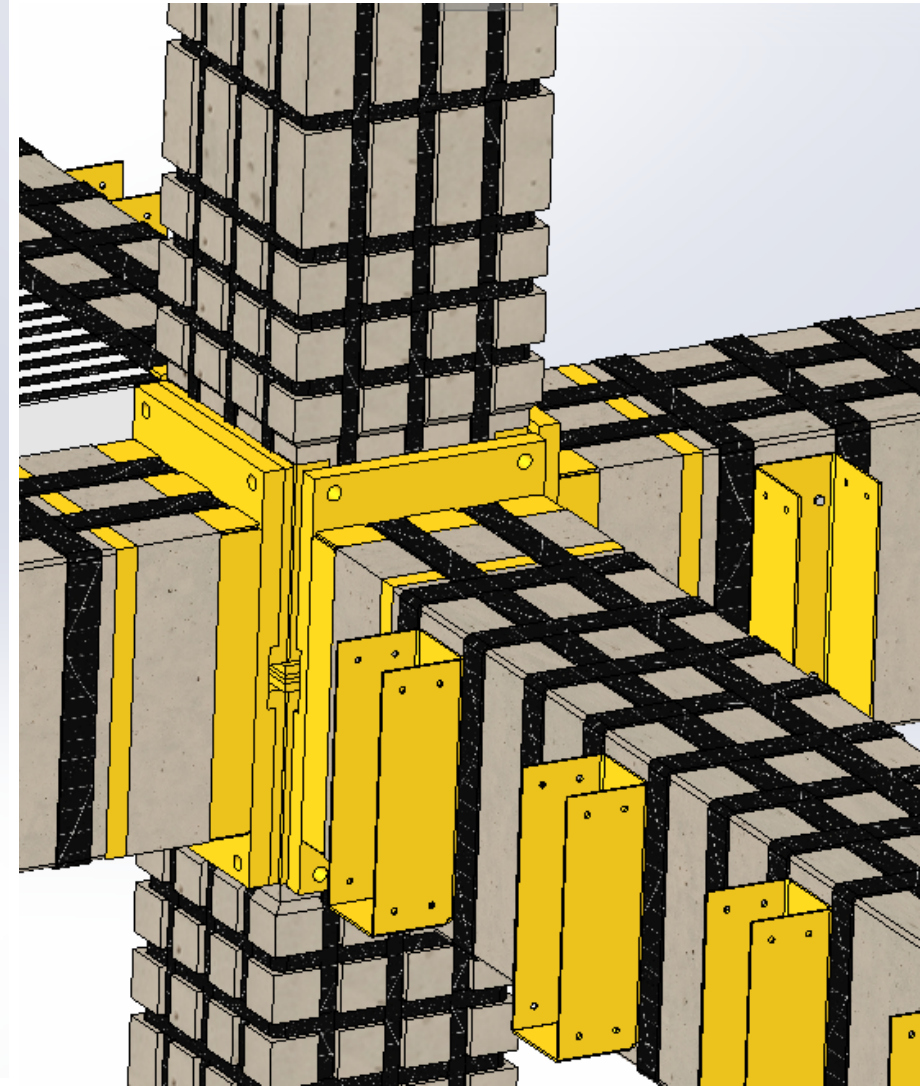
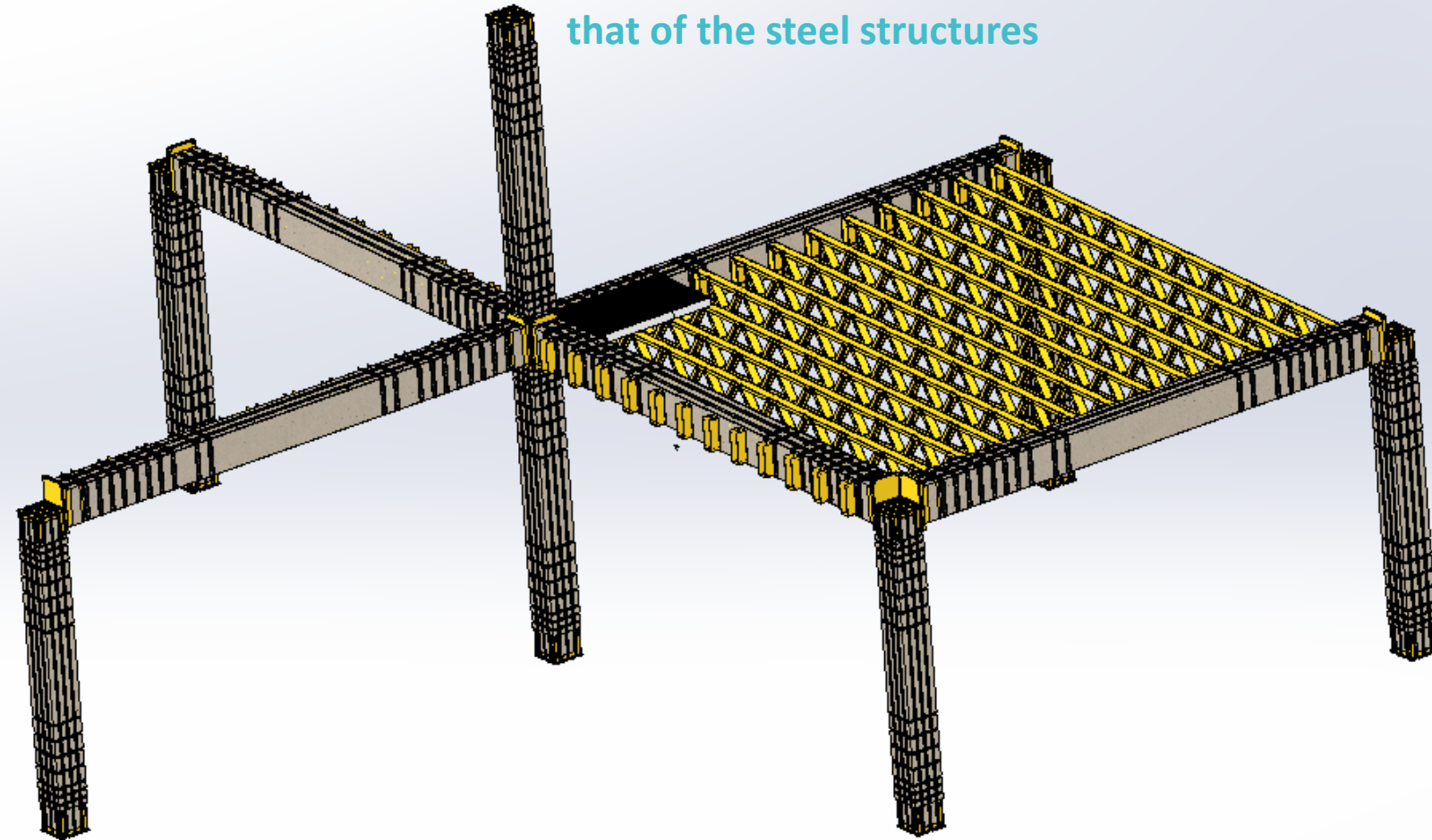

# FLEXSTREN WALLS / INSULATED CLADDING SYSTEM

with very limited thermal and acoustic conductivity

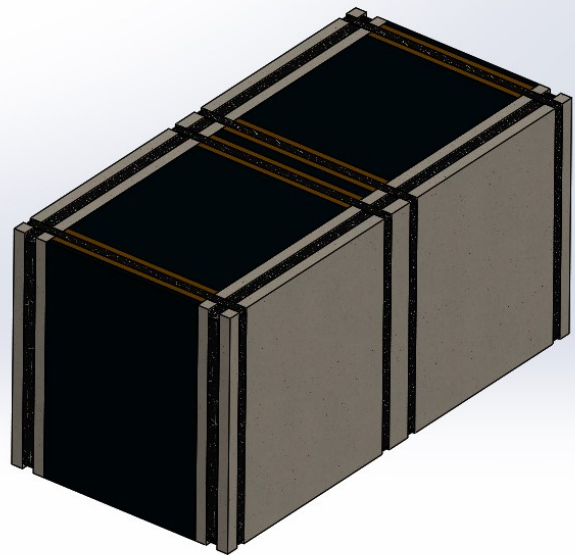
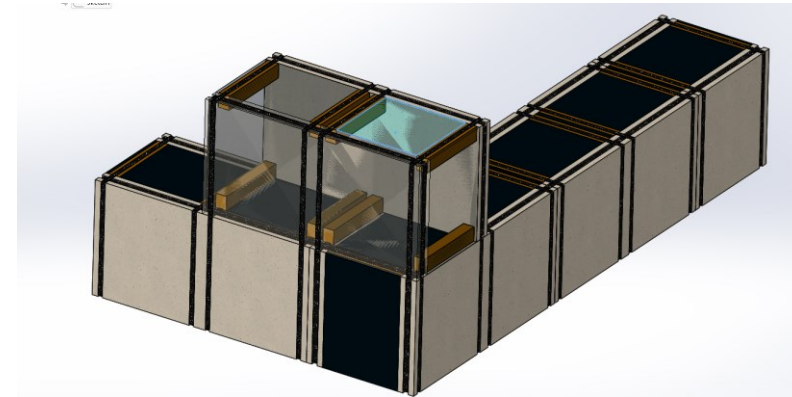
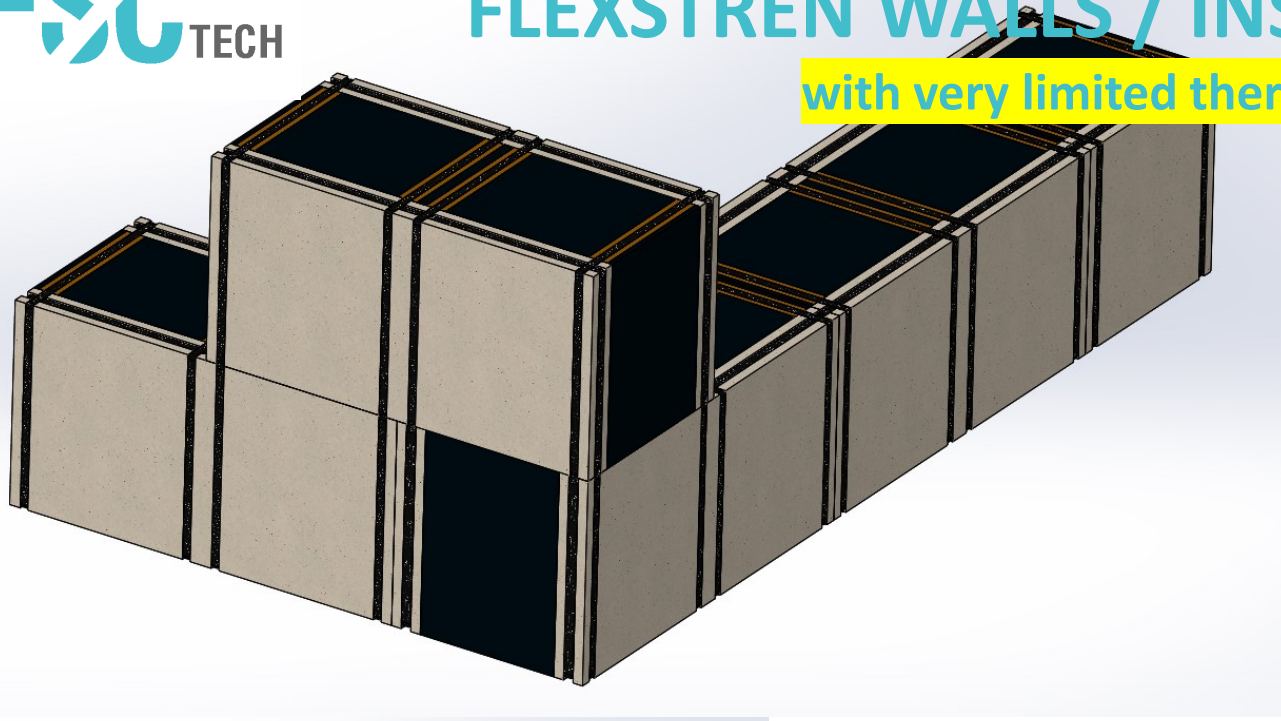

Each element it looks like a block, but it consists of 2 external dry cast slabs and some Polymer concrete spacers, put together with the FLEXSTREN wrapping

The interior can be filled with any organic and inorganic insulation material, which is not bearing any load

An average strength of 5 MpA can be reached, and therefore - in addition of cladding applications - it can be considered a structural element for most of the codes



# MULTIAXIAL POSTCOMPRESSION SYSTEM

(PAT - Pressure Activated Tendon)

## How it works

A special tube wrapped with the FRP tape is placed under pressure causing it to stretch in the axial direction

After concrete casting and curing, the pressure is removed, and this causes a post compression in the concrete

This post compression can be multi axial

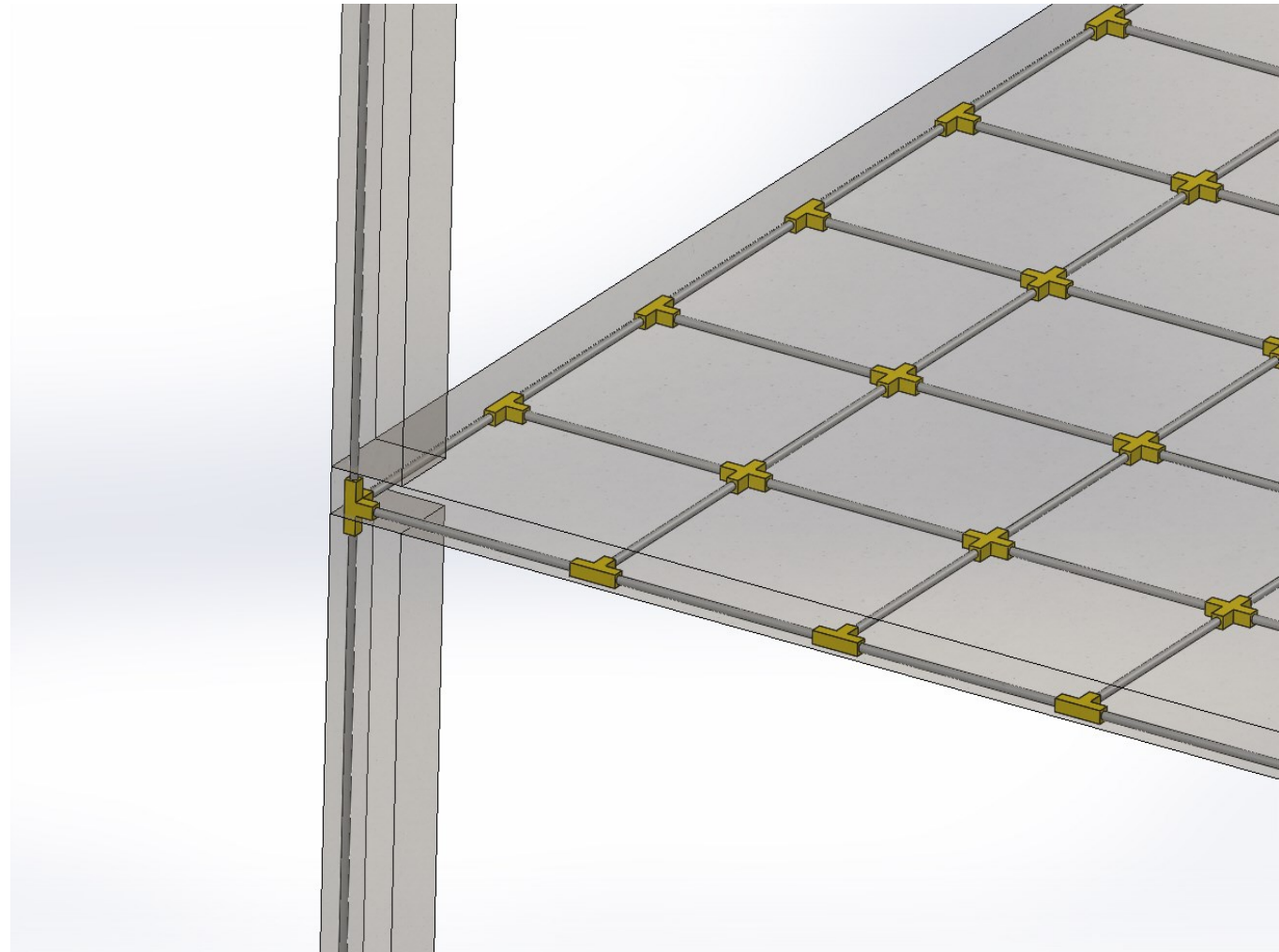



# MULTIAXIAL POSTCOMPRESSION SYSTEM

(PAT - Pressure Activated Tendon)

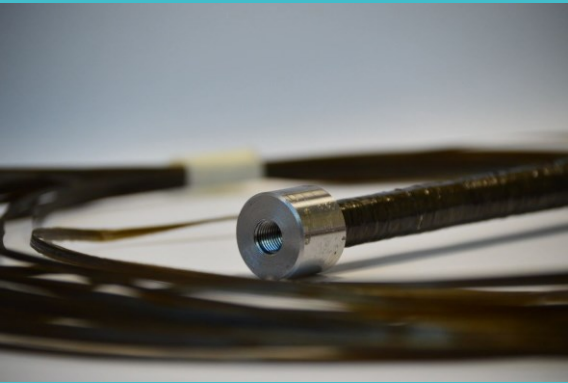

It is used to replace steel reinforcing in cast in situ

Also applicable to joint less roads and airport runways (very low maintenance and long life)

for highly fire resistant and seismic resistant buildings

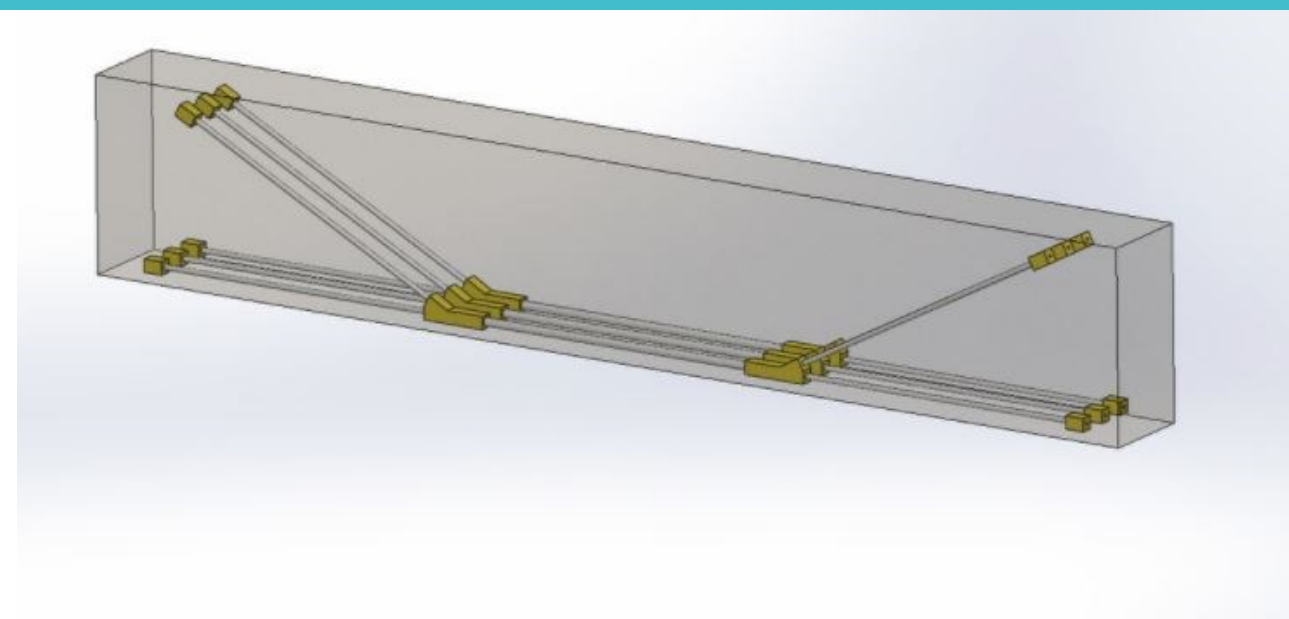

## FLEXSTREN for the Mechanical, Aerospace, and Energy Industries

- **It overcomes the lack of efficient and eco-sustainable structural technologies capable of conferring flexural strength to materials with “ceramic behavior”, which are characterized by high compressive strength and low tensile / flexural strength.**
- **It opens other applications both for high temperatures and as a replacement for forged steel.**



# FSC TECH- Innovative Structural Technologies

500 Westover Drive, #91583 Sanford NC, 27330, USA  
phone +1 (321) 710-9286

R&D Branch: via V. Veneto 52, 43046 Rubbiano PR, ITALY  
phone +39 338 052 5728

[info@fsc-tech.com](mailto:info@fsc-tech.com) - [www.fsc-tech.com](http://www.fsc-tech.com)

