

Complete range of automation systems for sliding pedestrian doors with a maximum leaf weight of 150 kg. The control unit, with a programming display and microprocessor technology, makes it possible to control all the main functions automatically.

The cushioned rail and shaped wheels ensure absolutely silent movement.

La rotaia ammortizzata e le ruote sagomate garantiscono l'assoluta silenziosità del movimento. Protocollo di interconnettività U-Link

DIMENSION (MM)

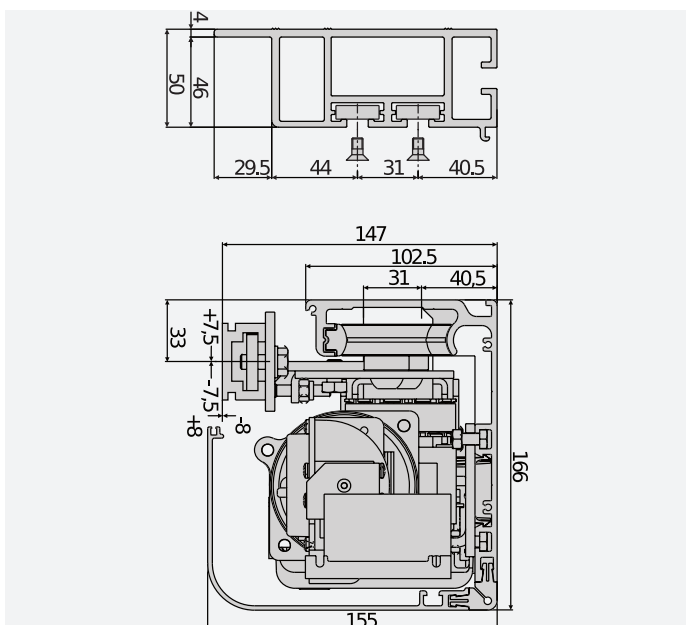

Technical features

	VISTA SL-1	VISTA SL-2
Control unit	ARIA EVO	
Supply voltage AC	24 V	24 V
Nominal power consumption	230 W	230 W
Leaf type	Sliding	Sliding
Number of doors	1	2
Door weight	150 kg	120+120 kg
Manual cycle	Reversible	Reversible
Motor type	Dunker motor	Dunker motor
Type of limit switch	Encoder + mechanical stop for opening	Encoder + mechanical stop for opening
Clear opening	750÷2550 mm	900÷2900 mm
Opening speed	up to 100	up to 200
Closing speed	up to 100	up to 200
Approach speed	5 ÷ 10	5 ÷ 10
Locking	Mechanical	Mechanical
Release	Release lever	Release lever
Impact reaction	Electronic torque limiter	Electronic torque limiter
Use cycle	Continuous	Continuous
Protection rating	IPX0	
Environmental conditions	50 °C	



		Description	
P960529 00002	VISTA SL-225	Operator for pedestrian sliding doors with 2 leaf with max weight 120+120 kg. useful passage 2500 mm and crosspiece width 5200 mm. For very heavy gate leaves.	 U-Link
P960531 00002	VISTA SL-229	Operator for pedestrian sliding doors with 2 leaf with max weight 120+120 kg. useful passage 2900 mm and crosspiece width 6000 mm. For very heavy gate leaves.	 U-Link

ARIA EVO: Control unit for pedestrian doors.

ARIA EVO - Built-In















- Control unit for pedestrian doors
- Application: control unit for pedestrian doors
- Board power supply: 230V single-phase
- Operator power supply: 24V
- Main features: programming with display, incorporated dual channel receiver, anti-crushing, slowdown during opening and closing
- Main functions: automatic re-closing, alarms management, anti-break-in logics

VISTA SL

	D113722 - VISTA SEL Function selector for pedestrian door series VISTA SL, SL C, TL.		P111768 - BBV BATT MODULO VISTA SL Set of backup batteries for VISTA SL.
	P111445 - SBV Anodised aluminium supporting crosspiece for VISTA SL.		P111681 - PRV AA SL Leaf attachment profile for Vista SL. L = 2600 mm.
	P111680 - WMP SL SLC Contains 2 crossbeam support profiles of length L = 1 m each.		N733408 - ERV Solenoid lock assembly for VISTA SL/SL C, (use with BBV recommended) ERV.
	N733534 - ELA SL 24.B KIT		P111156 - PPR Door guide slide for automatic doors with aluminium frame.
	P111158 - PGI Bottom door guide for automatic doors with aluminium frame.		P111163 00002 - SASAM 1 Antipanic breakthrough system in anodised aluminium, 1 leaf. Length mx 1100 mm.



VISTA SL

	<p>P111263 00002 - SASAM 2</p> <p>Antipanic breakthrough system in anodised aluminium, 2 leaves. Length mx 1100 mm.</p>		<p>P121016 - RB</p> <p>4-channel wall-mounted radio control with rolling code.</p>
	<p>new P111653 - VIO-DT2</p> <p>Safety and bi-directional activation sensor, dual technology, monitored.</p>		<p>new P111654 - VIO-DT1</p> <p>Safety and mono-directional activation sensor, dual technology, monitored.</p>
	<p>new P111655 - IXIO-DT1</p> <p>Safety and mono-directional activation sensor, dual technology, monitored, programmable c.telecom.</p>		<p>new P111656 - VIO-ST</p> <p>Infrared safety sensor, monitored.</p>
	<p>new P111662 - VIO-M</p> <p>Compact mono-directional activation sensor.</p>		<p>new P111676 - MAGIC SWITCH</p> <p>Activation touch button.</p>
	<p>new P111677 - PUSH PLATE</p> <p>Activation button.</p>		<p>new P111678 - SPAC</p> <p>Pair of locks (2) for glass leaf.</p>
	<p>new P111687 - KIT FPA MA-12</p> <p>FPA MA 12 kit with two pairs photocells and brackets for Vista.</p>		<p>new P111685 - KIT FPA2</p> <p>FPA kit with two pairs photocells and brackets for Vista.</p>



VISTA SL

	<p>new P111683 - KIT FPA1</p> <p>FPA kit with pair of photocells and brackets for Vista.</p>			
--	--	--	--	--

