

SigTEL

1 to 64 line emergency
voice communication
system



disabled refuge systems
fire telephone systems
stadium marshalling systems

You're safe with



SigTEL

1 to 64 line emergency voice communication system



For most people, a simple instruction like “please leave the building by the nearest available exit” can be acted upon quickly and easily. But for wheelchair users, the disabled and infirm, this isn't always the case.

Current Building Regulations recognise this and insist all new non-domestic buildings with more than one storey provide 'refuge' areas – relatively safe places where people who cannot easily use fire escapes and evacuation lifts can call for assistance and wait until help arrives.

Simple, effective two-way communication in these areas is essential, firstly to assist rescue teams in determining where assistance is required and secondly to reassure people help is on the way.

Communication systems in refuge areas are known as Emergency Voice Communication (EVC) Systems and SigTEL is suitable for use in all types of EVC application – be it a disabled refuge, fire telephone or stadium marshalling system.

Incredibly easy to use and offering true duplex speech, SigTEL meets and exceeds the requirements of standards such as BS 5839 part 9 in all areas and is hugely cost-effective in comparison to other systems on the market.



Key features of the SigTEL emergency voice communication system

- ▶ Ideal for all disabled refuge, fire telephone and stadium marshalling applications
- ▶ Compact 4 or 8 line wall-mounting master controllers save valuable space in crowded control rooms
- ▶ 8 line expansion unit allows a 4 or 8 line master controller to be easily expanded to 12 or 16 lines
- ▶ Powerful networking facility allows up to four master controllers (plus any expansion units) to be interlinked allowing systems of up to 64 lines to be easily implemented
- ▶ Optional anti-tamper enclosures available for controllers located in areas accessible to the public
- ▶ Wide range of 'Disabled Refuge' (Type B) outstations available in stainless steel or green steel (flush, surface or weatherproof options available)
- ▶ 'Fire Telephone' (Type A) outstations available in locking or non-locking red steel cabinets
- ▶ All outstations offer true duplex speech and can be mixed and matched to suit the application
- ▶ Unique 'auto-learn' facility allows fast system set up
- ▶ Devices can be named/edited using the buttons on a master controller or via an optional PC programming configurator (part no. EVC423).
- ▶ All extensions can be named with user-defined text of up to 15 characters
- ▶ Fully monitored hardware and software
- ▶ System operates at 24 VDC. In the event of mains failure, operation can be maintained for 24 hours (standby) and 3 hours (in use) using 2 x 12V 7 Ahr batteries
- ▶ Optional FiTT line tester allows cable faults to be checked prior to equipment connection
- ▶ Can be easily interfaced to many disabled persons toilet alarm systems, audio-frequency induction loop systems, strobes, beacons or CCTV activation relays
- ▶ Ideal for hotels, shopping malls, office blocks, transport terminals, banks, sports stadiums, entertainment complexes, etc.

SigTEL Controllers

SigTEL comprises a range of low-cost wall-mounting Controllers which can handle 4 or 8 lines (dependent on the model purchased). Typically located in a building's control room or a fire services access point, each Controller allows management and/or the emergency services to communicate via telephone-style handsets with the system's 'outstations'. For larger systems, an 8 line expansion unit allows systems of up to 12 or 16 lines to be easily implemented. An optional network communication card can be used to interlink up to four Master Controllers for systems of up to 64 lines.

SigTEL Master Controllers (ECU-4 / ECU-8)

- Allows operators to communicate with the system's outstations
- ECU-4 can be connected to up to 4 outstations
- ECU-8 can be connected to up to 8 outstations
- Supplied with a backlit LCD and handset
- Requires 2 x 12V 7.0 Ah batteries
- Can be semi-flush mounted using the AFP385 bezel
- Optional tamper-resistant cabinets also available



SigTEL 8 Line Expansion Unit (ECU-8S)

- Can be connected to an ECU-4 or ECU-8 master controller to increase its line capacity to 12 or 16 lines respectively
- Does not require a separate mains supply or batteries
- Can be semi-flush mounted using the AFP385 bezel



Network Communication Card (ECU721)

- Allows the interconnection of up to 4 master controllers over a 1KM network
- One card required per networked master controller
- Allows systems of up to 64 lines (four ECU-8 masters each with an ECU-8S slave) to be easily set-up
- Any ECU-4 or ECU-8 can take control of the system at any time by the input of a special code
- For networked systems that do not require multiple control points, Master Controllers without handsets are available (ECU-8NT)



Anti-tamper Stainless Steel Enclosure (BF359/3D)

- An attractive flush-mounting tamper-resistant cabinet for housing an ECU-4 or ECU-8 master controller
- Helps ensure controllers remain operational at all times by reducing the risk of vandalism
- Two lock kits also available - a CAM lock kit (BF359/3CL) and an electromagnetic solenoid kit (BF359/3SL)
- Surface mounting grey steel enclosures (BF359/2) also available - call our sales desk for details



controller not included

SigTEL Disabled Refuge & Fire Telephone Outstations

Two types of outstation are available - Type B (handsfree intercom-style) outstations for disabled refuge applications and Type A (telephone-style) outstations for fire telephone and/or stadium marshalling applications. Both versions offer high quality, full duplex speech and connect to a SigTEL ECU-4 or ECU-8 Controller (or 8 line expansion unit) using two cores of 1.5mm² of enhanced fire rated cable of up to 1 KM in length.

Type B Green Refuge Outstations (EVC302GF / EVC302GS)

- Allows anyone in a disabled refuge to communicate with building control at the touch of a button and vice versa
- Finished in tough, durable green steel
- Flush (EVC302GF) and surface (EVC302GS) versions available
- Includes connections for an optional induction loop system
- Easily interfaced to strobes, CCTV activation relays and/or disabled toilet alarm systems



Type B Stainless Steel Refuge Outstations (EVC302F / EVC302S)

- Allows anyone in a disabled refuge to communicate with building control at the touch of a button and vice versa
- High-quality brushed stainless steel finish
- Flush (EVC302F) and surface (EVC302S) versions available
- Includes connections for an optional induction loop system
- Easily interfaced to strobes, CCTV activation relays and/or disabled toilet alarm systems



Weather resistant Enclosure for Type B outstations (BF359G/1)

- An IP65 rated weather resistant enclosure designed for use with our Type B flush disabled refuge outstations
- Allows an IP65 rated Type B disabled refuge outstation to be created for use in external areas such as car parks, etc.



Type A Fire Telephone Outstations (EVC301RPO / RLK)

- Designed for use in fire telephone and stadium marshalling applications
- Allows fire marshals/stewards to communicate with building control via a telephone handset and vice versa
- EVC301RPO includes a telephone handset in a push-to-open red steel cabinet. EVC301RLK is the same but has a 'lift-key' lock mechanism
- Both versions can be flush mounted using a T-BE2301 bezel



SigTEL Accessories

A range of cost-effective SigTEL accessories comprising a programming configurator (to speed up the naming/editing of extensions), a battery-operated line tester (to simplify installation and commissioning), a blue and amber strobe (to provide visual indication of an incoming call), an audio-frequency induction loop system (to assist the hard of hearing) and a disabled persons toilet alarm system (to allow communication to take place in accessible toilet areas).

EVC423 Programming Configurator

- Facilitates quick and easy editing of outstation/extension names via a Windows-compatible PC
- Includes a software CD, configurator and mini USB to master controller connection lead
- Set up can be saved to, and from, a PC



XSB / XSA Xenon Strobes

- Can be interfaced to a Type A or Type B outstation to provide visual indication of incoming calls
- Amber (XSA) and Blue (XSB) versions available
- Each strobe requires an SDM Driver Module (see right) & 12V 1A PSU

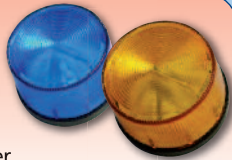

FITT Line Tester

- A must-have commissioning tool
- Allows cable faults to be checked and cleared prior to equipment connection
- Includes all of the test cables and connectors you need



ML1/K1 Audio-Frequency Induction Loop Kit

- A cost-effective induction loop system easily interfaced to a Type B outstation's loop connectors
- Exceeds the magnetic field strength requirements of BS EN60118-4 when the loop is correctly installed at ceiling or floor height (exact location will depend on the application and building)
- Helps facilitate compliance with the Equality Act



NC951 Disabled Persons Toilet Alarm Kit

- Includes everything required for a BS8300 compliant emergency assistance alarm
- Easily interfaced to a SigTEL master controller or Type B outstation via its volt-free relay contacts



If connecting to a Type B outstation, activation of the WC alarm will have the same effect as pressing the outstation's call button. When the call is answered, a direct speech channel will be established between controller and outstation. If connecting to a master controller, a WC call will appear on the controller's display to show somebody needs help but no speech channel will be opened.

SigTEL Roaming Handsets and Jack Plates

EVC301/JP Fire Telephone Jack Plate

- Ideal for use in regions where 'roaming handsets' are allowed (typically the Far and Middle East. Not for use in the UK)
- Multiple jack plates can be connected to a single SigTEL line in stairwells/risers, etc.,
- All plates include a 1/4" jack socket.



EVC301/PH Portable Handset

- Plugs into an EVC301-JP jack plate
- Once inserted, a call will be made to the SigTEL controller from where a speech channel can be opened.
- Refer to our Roaming Handset datasheet for further details.



SigTEL Wiring Overview

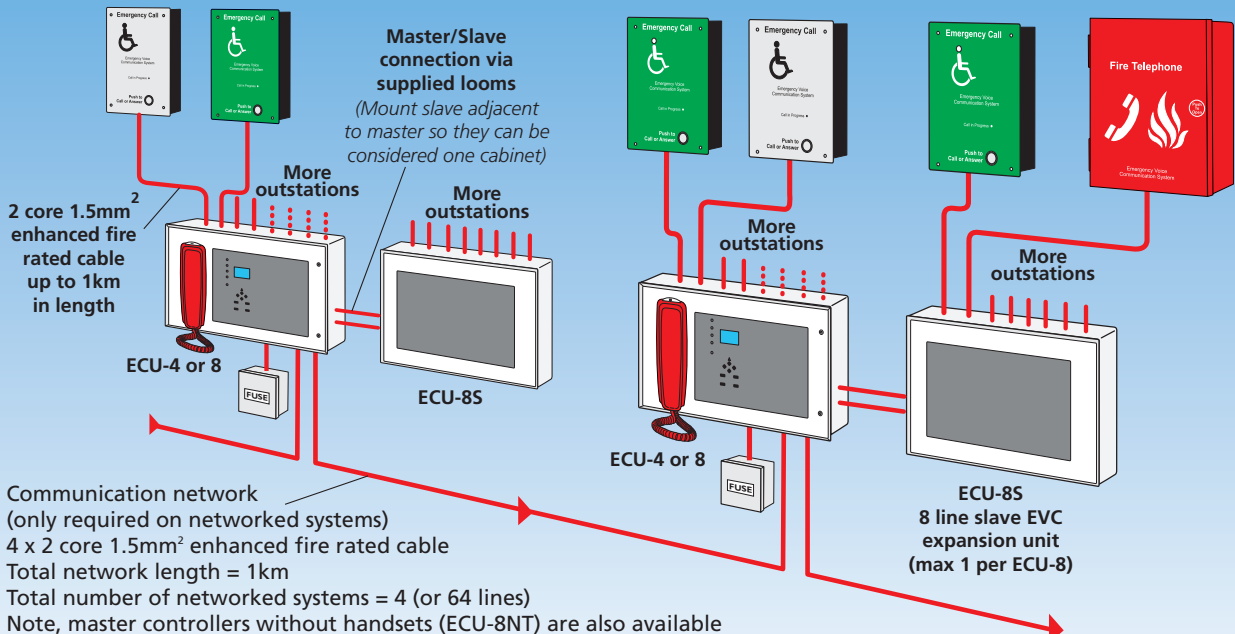

What is an Emergency Voice Communication (EVC) System?

An emergency voice communication system is a life safety intercom (or telephone) system designed to operate reliably in a fire alarm emergency. Its equipment and wiring must be monitored for faults that might occur prior to the emergency and its cabling and battery backup supply must ensure it keeps working during the emergency. According to BS5839 part 9, there are two types of EVC system; disabled refuge and fire telephone. They may be separate, or they may be combined into one system.

Disabled refuge systems

A disabled refuge system typically connects handsfree intercom outstations to a central control room and is used to inform management that someone needs immediate assistance to exit the building.

Fire telephone systems

A fire telephone system is used by management (and marshals at a sports ground) and the fire service before, during and after a fire to communicate with fire marshals and fire fighters.

Regulations affecting EVC systems?

The installation of an emergency voice communication system is governed by BS5839 Part 9: Code of practice for the design, installation, commissioning and maintenance of emergency voice communication systems.

Disabled Refuge Systems are called for by:

- Building Regulations; Approved Document B (Fire Safety); Volume 2, Section 4: Design for vertical escapes
- BS9999: Code of practice for fire safety in the design, management & use of buildings; Clause 41.9 Communications; Clause 46.8 Use of refuges
- Regulatory Reform Order (Fire Safety Order) Oct 2005 *Risk assessments undertaken by the responsible person must make provision for means of escape for disabled people.* Supplementary Guide: Means of escape for disabled people
- Equality Act 2010 (supersedes the Disability Discrimination Act)
- UN Convention on the rights of people with disabilities

Fire telephone systems are called for by:

- BS9999: Code of practice for fire safety in the design, management and use of buildings; Clause 24 Communication systems for fire and rescue service use
- London District Surveyors Association in conjunction with LFCDA Fire Safety Guide No. 3; Section 2: Fire Safety Measures
- London Fire and Civil Defence Authority (London Fire Brigade) Fire Safety Guidance Note Number: 30 (Rev 3)
- Guide to safety at sports grounds; 16.11: Telephone communications – internal

Where are disabled refuges / Type B outstations required?

Refuge areas are called for in all non-domestic buildings with more than one storey and they should be provided at each storey exit (i.e. each protected stairway affording egress).

Examples of a refuge area include an enclosure such as a protected lobby, corridor or stairway or an area in open air such as a flat roof, balcony, podium or similar place which is sufficiently protected (or remote) from any risk of fire and has its own means of escape.

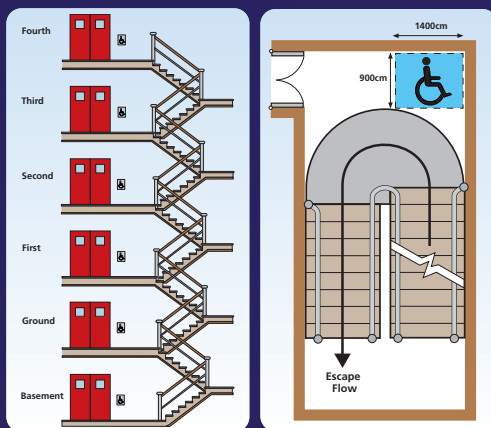

Examples of a Type B outstation installed in the protected stairway providing egress from each storey

Type B outstations should be provided in all refuge areas. They should be wall mounted, in an easily accessible, well illuminated and unobstructed position 900 mm to 1.2 m above the ground. They should allow members of the evacuation team to determine how many disabled people there are, the nature of their disabilities and the refuges in which they are located.

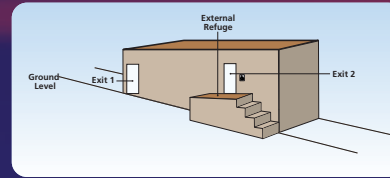

Example of a Type B outstation installed on an external fire escape staircase providing egress from each storey (right) and the final exit (left).

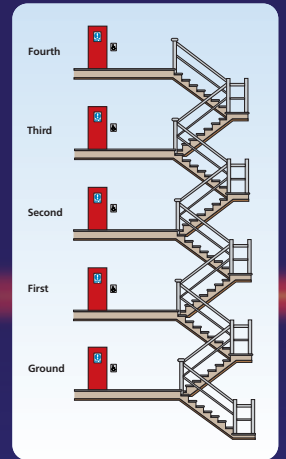

Note that refuges are intended for temporary use only (a few minutes) whilst building management are sending trained staff to deal with the evacuation and should not be confused with “places of relative safety”.

Where are fire telephones / Type A outstations required?

In buildings which require a fire telephone system, Type A outstations should be located at every fire fighting entrance point, fire escape landing and fire fighting lobby. They should be wall mounted 1.3 m to 1.4 m above the ground in an easily accessible, well-illuminated and unobstructed position.

In sports stadiums, emergency telephones should be located no more than 30 metres from stewards' positions or other normally manned areas such as turnstiles, public address operating booths, offices of senior officials, lighting control points, first aid rooms, police rooms, etc.

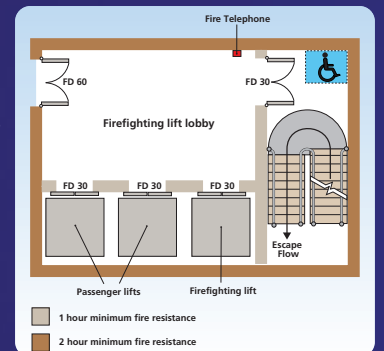

Example of a Type A outstation installed opposite a fire fighting lift within the fire fighting lift lobby on each floor

They should allow communication between management and/or fire marshals and/or the fire service before, during and after a fire.

Master Controller Location

The system's Master Controller should be located in the control room, security room or next to the main fire panel or repeater panel and it should be permanently manned in an emergency. The centre of the Controller's controls (if wall mounted) for a standing operator should be 1.4 m to 1.5 m above the floor.

If the power supply to the Controller fails, the batteries provided should run the system in its quiescent state for at least 24 hours and then allow emergency voice communication for at least 3 hours. The Controller (and all Outstations) should also offer full duplex speech, i.e. the concurrent transmission and reception of speech in both directions.

Communication between the Controller and an Outstation should normally be initiated from the Outstation. However, the ability to call an Outstation from a Controller is also allowed. Indeed, standards such as BS5588 part 8 acknowledge keeping people informed during an emergency will help avoid anxiety and confusion.

Cables, wiring and interconnections

All of the cables used in an EVC system should be of enhanced fire resistance (26.2e of BS 5839-1:2002) except for underground sections of cabling at sports grounds.

Inspection and servicing

Inspection and servicing should be carried out every six months by a competent person/organisation with specialist knowledge of the installed equipment.

SigTEL Emergency Voice Communication System Technical Specifications

MASTER CONTROLLERS (ECU-4 / ECU-8 / ECU-8NT)

Power Supply	
Mains supply	230 VAC, 50/60 Hz
Power supply output 1	24 VDC
Power supply output 2	5 VDC
Output current @ 24 VDC	0.5 A max
Supply and batteries monitored for failure	Yes
Standby battery requirements (size and type)	2 x 12 V, 7 Ah VRLA (Valve Regulated Lead Acid) connected in series
Mains fuse 1 A (T)	20 mm HRC
Battery fuse 1 A (F)	20 mm
Max. current draw from battery (Mains failed)	500 mA (16 Type B outstations fitted (8 via an ECU-8S), one outstation connected, 15 outstations calling in)
Line specification	
Max. number of lines (ECU-4 version)	4 (expandable to 12 using ECU-8S expansion unit)
Max. number of lines (ECU-8 / ECU-8NT versions)	8 (expandable to 16 using ECU-8S expansion unit)
Number of outstations per line	1
Lines monitored for open and short circuit faults	Yes
Outstation cabling requirements	2 core 1mm ² or 1.5mm ² enhanced fire rated cable, up to 1km per line. Max cable resistance = 40 ohms
Output ratings	
OP1, OP2, OP3 open collector outputs	24 V, 50 mA max
Change-over relay	30 V, 1 A max
24 V output	200 mA max
Indicators, controls and physical appearance	
External indicators	LCD display, Disablement, System fault, PSU fault, General fault, Power On
External controls	Handset (ECU-4 & ECU-8 only), Scroll up, Scroll down, Hold, Call/Accept, Function, Directory, Silence Buzzer
Internal controls	Engineer mode button, Reset button
Dimensions / weight	W 412 x H 250 x D 80mm (base); W 435 x H 269 x D 11mm (lid); 3.1kg
Physical appearance	Lid and base RAL7305 (Grey texture), label background Pantone 429C
Network specification	
Max no. of master controllers per network	4 (any mix of ECU-4s, ECU-8s or ECU-8NTs)
Connection	Via ECU721 network communication card, one required per networked master
Network cabling requirements	4 x 2 core 1.5mm ² enhanced fire rated cable, up to 1km in length
Optional BF359/3D stainless steel enclosure	Dimensions: W 725 x H 448 x D 193mm
Optional BF359/2 grey steel enclosure	Dimensions: W 603 x H 465 x D 200mm

EXPANSION UNITS (ECU-8S)

Mains supply and standby battery requirements	Not applicable (power derived from ECU-4, ECU-8 or ECU-8NT master controller)
Cabling requirements (from ECU-4, ECU-8 or ECU-8NT)	2 x CAT 5 patch leads (supplied). These must be protected to BS5839 standards by joining the two cabinets with a short length of 25mm steel conduit (45 to 60mm in length) and passing the cables through
Dimensions / weight	W 412 x H 250 x D 80mm (base); W 435 x H 269 x D 11mm (lid); 3.1kg
Physical appearance	Lid and base RAL7305 (Grey texture), label background Pantone 429C

DISABLED REFUGE (TYPE B) OUTSTATIONS (EVC302GF / EVC302GS / EVC302F / EVC302S)

Input voltage (from controller)	5 VDC in use, 10.7 VDC quiescent;
Current consumption @ 24 VDC	25 mA in use, 3 mA quiescent
Frequency response	250 Hz to 5 kHz ±3 dB (microphone); 250 Hz to 4 kHz ±3 dB (loudspeaker)
Audio output level	0 dB (775 mV) balanced line level
Switch output	Opto-isolated normally open open-collector, max 24 VDC 3 mA
External indicators	Red call in progress LED
Controls	External Push to Call or Answer button (Off Hook); Internal Loudspeaker volume & Engineer's On Hook pins
Physical appearance	Green steel fascia (EVC302GF/GS); Stainless steel fascia (EVC302F/S); Jet black RAL9005 base (all models)
Dimensions & Weight (Flush versions)	W 175 x H 250 D 55mm (assembled); W 152 x H 228 x D 53mm (back box only); 1.4kg
Dimensions & Weight (Surface versions)	W 175 x H 240 x D 53mm (assembled); 1.4kg
Optional BF359G/1 weather resistant enclosure	Dimensions: W 215 (does not include 15mm "opening tag") x H 284 x D 75mm approx.

FIRE TELEPHONE (TYPE A) OUTSTATIONS (EVC301RPO / EVC301RLK)

Input voltage (from controller)	5 VDC in use, 10.7 VDC quiescent;
Current consumption @ 24 VDC	25 mA in use, 1 mA quiescent
Frequency response	250 Hz to 5 kHz ±3 dB (microphone); 250 Hz to 4 kHz ±3 dB (earpiece)
Audio output level	0 dB (775 mV) balanced line level
Controls	Lifting telephone handset makes unit Off Hook
EVC301RPO / EVC301RLK Dimension/Weight	W 202 x H 278 x D 1005mm; 3Kg
T-BEZ301 Dimensions/Weight	W 244 x H 320 x D 20mm; 0.5kg
Physical appearance	Red RAL3000



Manufactured by C-TEC, Challenge Way, Wigan, WN5 0LD. England

UK Sales: Tel: 01942 322744. Fax: 01942 829867. Email: sales@c-tec.co.uk
 European Sales: Tel: +44 1942 322744. Fax: +44 1942 829867. Email: eu.exports@c-tec.co.uk
 Export Sales: Tel: +44 161 257 2541. Fax: +44 161 225 8817. Email: xportsales@xportsales.com

www.c-tec.co.uk

© C-TEC. Approved Doc. No. DML05351000 Rev 1. E&OE. C-TEC operates a policy of continuous improvement & reserves the right to alter product specifications at its discretion & without prior notice.



Quality System Certificate No: 176
Assessed to ISO9001 : 2008

