

SPACE CONSTRAINED AIR CONDITIONER/HEAT PUMP

INSTALLATION INSTRUCTIONS & OWNER'S MANUAL

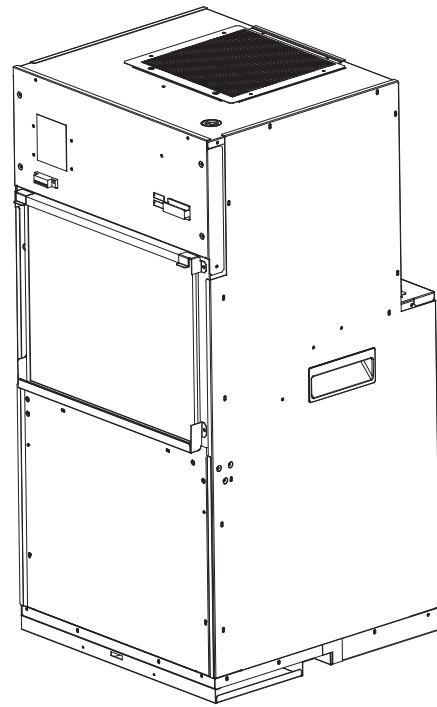
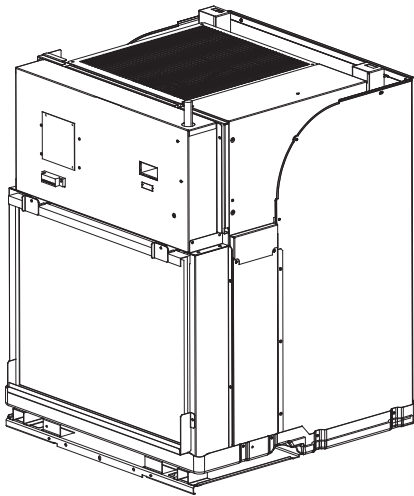

ATTENTION INSTALLATION PROFESSIONAL

As a professional installer you have an obligation to know the product better than the customer. This includes all safety precautions and related items.

Prior to actual installation, thoroughly familiarize yourself with this instruction manual. Pay special attention to all safety warnings.

Often during installation or repair it is possible to place yourself in a position which is more hazardous than when the unit is in operation.

Remember it is your responsibility to install the product safely and to know it well enough to be able to instruct a customer in its safe use.

Safety is a matter of common sense, a matter of thinking before acting. Most dealers have a list of specific good safety practices, follow them.

The precautions listed in this Installation Manual are intended as supplemental to existing practices. However, if there a direct conflict between existing practices and the content of this manual, the precautions listed here take precedence.

IMPORTANT NOTES:

Before using this manual, check the serial plate for proper model identification.

Due to policy of continual product improvement, the right is reserved to change specifications and design without notice.

QUALIFICATION OF WORKERS

The installation and servicing of this equipment must be performed by qualified, experienced technicians only. Professional installation personnel should have the following experience:

- Installing the electric heater
- Opening of sealed components
- Opening of ventilated enclosures
- Commissioning and troubleshooting
- Checking the electric control part and wiring
- Breaking into the refrigerant circuit and charging

IMPORTANT NOTE TO THE OWNER

This manual is to be used by qualified, professionally trained HVAC technicians only. The manufacturer does not assume any responsibility for property damage or personal injury for improper service procedures or services performed by an unqualified Person.

IMPORTANT NOTE TO THE SERVICER

Read this manual and familiarize yourself with the specific items which must be adhered to before attempting to service this unit. The precautions listed in this Installation Manual are intended as supplemental to existing practices. However, if there is a direct conflict between existing practices and the content of this manual, the precautions listed here take precedence.

TRANSPORT OF EQUIPMENT CONTAINING FLAMMABLE REFRIGERANTS

Attention is drawn to the fact that additional transportation regulations may exist with respect to equipment containing flammable gas. The maximum number of pieces of equipment or the configuration of the equipment permitted to be transported together will be determined by the applicable transport regulations.

CONTENTS

SAFETY PRECAUTIONS FOR R32 REFRIGERANT.....	1
CARE AND CLEANING.....	5
INSTALLATION INSTRUCTIONS.....	6
ELECTRICAL WIRING DIAGRAMS.....	22
OPERATING INSTRUCTIONS.....	24
ERROR CODE AND SOLUTIONS.....	29
NORMAL OPERATING SOUNDS AND CONDITIONS.....	30
TROUBLESHOOTING GUIDE.....	31

The following warnings are very important for safety. Please read them carefully before installation!

1. This unit must be properly installed in accordance with the Installation Instructions before it is used. See the Installation Instructions in the back of this manual.
2. Replace immediately all electric service cords that have become frayed or otherwise damaged. A damaged power supply cord must be replaced with a new power supply cord obtained from the manufacturer and not repaired. Do not use a cord that shows cracks or abrasion damage along its length or at either the plug or connector end. If the supply cord is damaged, it must be replaced by the manufacturer, it's service agent or similarly qualified persons in order to avoid a hazard.
3. Product must be operated with the electrical plug supplied with the product. Do not replace the electrical plug supplied with the product.
4. If the receptacle does not match the plug, the receptacle must be changed out by a qualified electrician.
5. Unplug or disconnect the unit at the fuse box or circuit breaker before making any repairs.
NOTE: We strongly recommend that any servicing be performed by a qualified individual.
6. All air conditioners contain refrigerants which under federal law must be removed prior to product disposal. If you are getting rid of an old product with refrigerants, check with the company handling disposal about what to do.
7. These R32 Air Conditioner Systems require contractors and technicians to use tools, equipment and safety standards approved for use with this refrigerant. Do not use equipment certified for R22 refrigerant only.
8. The minimum clearance to combustible surfaces (curtains, blinds, etc) from the appliance should be 300mm.
9. The appliance must be installed by certificated installer. It's forbidden to install by those amateur.
10. The appliance shall be installed in accordance with national wiring regulations.
11. This appliance is not intended for use by persons (including children) with reduced physical, sensory or mental capabilities, or lack of experience and knowledge, unless they have been given supervision or instruction concerning use of the appliance by a person responsible for their safety.
12. Children should be supervised to ensure that they do not play with the appliance.

RECOGNIZE THIS SYMBOL AS A SAFETY PRECAUTION

WARNING

THE MANUFACTURER WILL NOT BE RESPONSIBLE FOR ANY INJURY OR PROPERTY, DAMAGE ARISING FROM IMPROPER SERVICE OR SERVICE PROCEDURES. IF YOU INSTALL OR PERFORM SERVICE ON THIS UNIT, YOU ASSUME RESPONSIBILITY FOR ANY PERSONAL INJURY OR PROPERTY DAMAGE WHICH MAY RESULT, MANY JURISDICTIONS REQUIRE A LICENSE TO INSTALL OR SERVICE HEATING AND AIR CONDITIONING EQUIPMENT.

WARNING





"RISK OF ELECTRIC SHOCK. CAN CAUSE INJURY OR DEATH .DISCONNECT ALL REMOTE ELECTRIC POWER SUPPLIES BEFORE SERVICING", or the equivalent.
For equipment with multiple hazardous voltage power supplies, this marking shall be located on all panels providing access to hazardous voltage uninsulated live parts.

NOTICE

1. INSTALLATION, SERVICE, MAINTENANCE AND REPAIR OF THIS UNIT MUST BE PERFORMED BY A CERTIFIED TECHNICIAN.
2. PRODUCT DECOMMISSIONING AND RECYCLING MUST BE PERFORMED BY A CERTIFIED TECHNICIAN.
3. THIS APPLIANCE IS NOT INTENDED FOR USE BY PERSONS (INCLUDING CHILDREN) WITH REDUCED PHYSICAL, SENSORY OR MENTAL CAPABILITIES, OR LACK OF EXPERIENCE AND KNOWLEDGE, UNLESS THEY HAVE BEEN GIVEN SUPERVISION OR INSTRUCTION CONCERNING USE OF THE APPLIANCE BY A PERSON RESPONSIBLE FOR THEIR SAFETY.
4. CHILDREN SHOULD BE SUPERVISED TO ENSURE THAT THEY DO NOT PLAY WITH THE APPLIANCE.
5. IF THE SUPPLY CORD IS DAMAGED, IT MUST BE REPLACED BY THE MANUFACTURER, ITS SERVICE AGENT OR SIMILARLY QUALIFIED PERSONS IN ORDER TO AVOID A HAZARD.
6. THE APPLIANCE SHALL BE INSTALLED IN ACCORDANCE WITH NATIONAL WIRING REGULATIONS.
7. THIS PRODUCT CAN EXPOSE YOU TO CHEMICALS INCLUDING LEAD AND LEAD COMPOUNDS, WHICH ARE KNOWN TO THE STATE OF CALIFORNIA TO CAUSE CANCER AND BIRTH DEFECTS OR OTHER REPRODUCTIVE HARM. FOR MORE INFORMATION GO TO www.P65Warnings.ca.gov.

WARNING

RISK OF FIRE - FLAMMABLE REFRIGERANT USED. TO BE REPAIRED ONLY BY TRAINED SERVICE PERSONNEL. DO NOT PUNCTURE REFRIGERANT TUBING. DISPOSE OF PROPERLY IN ACCORDANCE WITH FEDERAL OR LOCAL REGULATIONS.

 A2L	WARNING	THIS SYMBOL THAT THIS APPLIANCE USED A FLAMMABLE REFRIGERANT. IF THE REFRIGERANT IS LEAKED AND EXPOSED TO AN EXTERNAL IGNITION SOURCE, THERE IS A RISK OF FIRE.
	CAUTION	THIS SYMBOL THAT THE OPERATION MANUAL SHOULD BE READ CAREFULLY.
	CAUTION	THIS SYMBOL THAT A SERVICE PERSONNEL SHOULD BE HANDLING THIS EQUIPMENT WITH REFERENCE TO THE INSTALLATION MANUAL.
	CAUTION	THIS SYMBOL THAT INFORMATION IS AVAILABLE SUCH AS THE OPERATING MANUAL OR INSTALLATION MANUAL.

SAFETY PRECAUTIONS FOR R32 REFRIGERANT

1. Information on servicing

1.1 Checks to the area

- Prior to beginning work on systems containing FLAMMABLE REFRIGERANTS, safety checks are necessary to ensure that the risk of ignition is minimized.

1.2 Work procedure

- Work shall be undertaken under a controlled procedure so as to minimize the risk of a flammable gas or vapor being present while the work is being performed.

1.3 General work area

- All maintenance staff and others working in the local area shall be instructed on the nature of work being carried out. Work in confined spaces shall be avoided.

1.4 Checking for presence of refrigerant

- The area shall be checked with an appropriate refrigerant detector prior to and during work, to ensure the technician is aware of potentially toxic or flammable atmospheres. Ensure that the leak detection equipment being used is suitable for use with all applicable refrigerants, i.e., non-sparking, adequately sealed or intrinsically safe.

1.5 Presence of fire extinguisher

- If any hot work is to be conducted on the refrigerating equipment or any associated parts, appropriate fire extinguishing equipment shall be available to hand. Have a dry powder or CO₂ fire extinguisher adjacent to the charging area.

1.6 No ignition sources

- No person carrying out work in relation to a REFRIGERATING SYSTEM which involves exposing any pipe work shall use any sources of ignition in such a manner that it may lead to the risk of fire or explosion. All possible ignition sources, including cigarette smoking, should be kept sufficiently far away from the site of installation, repairing, removing and disposal, during which refrigerant can possibly be released to the surrounding space. Prior to work taking place, the area around the equipment is to be surveyed to make sure that there are no flammable hazards or ignition risks. "No Smoking" signs shall be displayed.

1.7 Ventilated area

- Ensure that the area is in the open or that it is adequately ventilated before breaking into the system or conducting any hot work. A degree of ventilation shall continue during the period that the work is carried out. The ventilation should safely disperse any released refrigerant and preferably expel it externally into the atmosphere.

1.8 Checks to the refrigerating equipment

- Where electrical components are being changed, they shall be fit for the purpose and to the correct specification. At all times, the manufacturer's maintenance and service guidelines shall be followed. If in doubt, consult the technical department for assistance.
- The following checks shall be applied to installations using FLAMMABLE REFRIGERANTS:
 - the actual REFRIGERANT CHARGE is in accordance with the room size in which the refrigerant containing parts are installed;
 - the ventilation machinery and outlets are operating adequately and are not obstructed;
 - if an indirect refrigerating circuit is being used, the secondary circuit shall be checked for the presence of refrigerant;
 - marking on the equipment continues to be visible and legible. Markings and signs that are illegible shall be corrected;
 - refrigerating pipe or components are installed in a position where they are unlikely to be exposed to any substance which may corrode refrigerant containing components, unless the components are constructed of materials which are inherently resistant to being corroded or are suitably protected against being so corroded.

1.9 Checks to electrical devices

- Repair and maintenance to electrical components shall include initial safety checks and component inspection procedures. If a fault exists that could compromise safety, then no electrical supply shall be connected to the circuit until it is satisfactorily dealt with. If the fault cannot be corrected immediately but it is necessary to continue operation, an adequate temporary solution shall be used. This shall be reported to the owner of the equipment so all parties are advised. Initial safety checks shall include:

- ensuring capacitors are discharged: this shall be done in a safe manner to avoid possibility of sparking;
- ensuring no live electrical components and wiring are exposed while charging, recovering or purging the system;
- ensuring there is continuity of earth bonding.

2. Sealed components

- Sealed electrical components shall be replaced.

3. Intrinsically safe components

- Intrinsically safe components must be replaced.

4. Cabling

- Check that cabling will not be subject to wear, corrosion, excessive pressure, vibration, sharp edges or any other adverse environmental effects. The check shall also take into account the effects of aging or continual vibration from sources such as compressors or fans.

5. Detection of flammable refrigerants

- Under no circumstances shall potential sources of ignition be used in the searching for or detection of refrigerant leaks. A halide torch (or any other detector using a naked flame) shall not be used.
- The following leak detection methods are deemed acceptable for all refrigerant systems. Electronic leak detectors may be used to detect refrigerant leaks but, in the case of FLAMMABLE REFRIGERANTS, the sensitivity may not be adequate, or may need re-calibration. (Detection equipment shall be calibrated in a refrigerant-free area.) Ensure that the detector is not a potential source of ignition and is suitable for the refrigerant used. Leak detection equipment shall be set at a percentage of the LFL of the refrigerant and shall be calibrated to the refrigerant employed, and the appropriate percentage of gas (25% maximum) is confirmed.
- Leak detection fluids are also suitable for use with most refrigerants but the use of detergents containing chlorine shall be avoided as the chlorine may react with the refrigerant and corrode the copper pipe-work.
- NOTE Examples of leak detection fluids are:
 - bubble method,
 - fluorescent method agents.
- If a leak is suspected, all naked flames shall be removed/extinguished.
- If a leakage of refrigerant is found which requires brazing, all of the refrigerant shall be recovered from the system, or isolated (by means of shut off valves) in a part of the system remote from the leak.

6. Removal and evacuation

- When breaking into the refrigerant circuit to make repairs – or for any other purpose – conventional procedures shall be used. However, for flammable refrigerants it is important that best practice be followed, since flammability is a consideration. The following procedure shall be adhered to:
 - safely remove refrigerant following local and national regulations;
 - purge the circuit with inert gas;
 - evacuate (optional for A2L);
 - purge with inert gas (optional for A2L);
 - open the circuit by cutting or brazing.
- The refrigerant charge shall be recovered into the correct recovery cylinders if venting is not allowed by local and national codes. For appliances containing flammable refrigerants, the system shall be purged with oxygen-free nitrogen to render the appliance safe for flammable refrigerants. This process might need to be repeated several times.

7. Charging procedures

- In addition to conventional charging procedures, the following requirements shall be followed:
 - Ensure that contamination of different refrigerants does not occur when using charging equipment. Hoses or lines shall be as short as possible to minimize the amount of refrigerant contained in them.
 - Cylinders shall be kept in an appropriate position according to the instructions.

- Ensure that the REFRIGERATING SYSTEM is earthed prior to charging the system with refrigerant.
- Label the system when charging is complete (if not already).
- Extreme care shall be taken not to overfill the REFRIGERATING SYSTEM.

Prior to recharging the system, it shall be pressure-tested with the appropriate purging gas. The system shall be leak-tested on completion of charging but prior to commissioning. A follow up leak test shall be carried out prior to leaving the site.

8. Decommissioning

Before carrying out this procedure, it is essential that the technician is completely familiar with the equipment and all its detail. It is recommended good practice that all refrigerants are recovered safely. Prior to the task being carried out, an oil and refrigerant sample shall be taken in case analysis is required prior to re-use of recovered refrigerant. It is essential that electrical power is available before the task is commenced.

- a) Become familiar with the equipment and its operation.
- b) Isolate system electrically.
- c) Before attempting the procedure, ensure that:
 - mechanical handling equipment is available, if required, for handling refrigerant cylinders;
 - all personal protective equipment is available and being used correctly;
 - the recovery process is supervised at all times by a competent person;
 - recovery equipment and cylinders conform to the appropriate standards.
- d) Pump down refrigerant system, if possible.
- e) If a vacuum is not possible, make a manifold so that refrigerant can be removed from various parts of the system.
- f) Make sure that cylinder is situated on the scales before recovery takes place.
- g) Start the recovery machine and operate in accordance with instructions.
- h) Do not overfill cylinders (no more than 80% volume liquid charge).
- i) Do not exceed the maximum working pressure of the cylinder, even temporarily.
- j) When the cylinders have been filled correctly and the process completed, make sure that the cylinders and the equipment are removed from site promptly and all isolation valves on the equipment are closed off.
- k) Recovered refrigerant shall not be charged into another REFRIGERATING SYSTEM unless it has been cleaned and checked.

9. Labelling

Equipment shall be labelled stating that it has been decommissioned and emptied of refrigerant. The label shall be dated and signed. For appliances containing FLAMMABLE REFRIGERANTS, ensure that there are labels on the equipment stating the equipment contains FLAMMABLE REFRIGERANT.

Compressed air or oxygen shall not be used for purging refrigerant systems. For appliances containing flammable refrigerants, refrigerant purging shall be achieved by breaking the vacuum in the system with oxygen-free nitrogen and continuing to fill until the working pressure is achieved, then venting to atmosphere, and finally pulling down to a vacuum (optional for A2L). This process shall be repeated until no refrigerant is within the system (optional for A2L). When the final oxygen-free nitrogen charge is used, the system shall be vented down to atmospheric pressure to enable work to take place. Ensure that the outlet for the vacuum pump is not close to any potential ignition sources and that ventilation is available.

10. Recovery

When removing refrigerant from a system, either for servicing or decommissioning, it is recommended good practice that all refrigerants are removed safely.

When transferring refrigerant into cylinders, ensure that only appropriate refrigerant recovery cylinders are employed. Ensure that the correct number of cylinders for holding the total system charge is available. All cylinders to be used are designated for the recovered refrigerant and labelled for that refrigerant (i.e., special cylinders for the recovery of refrigerant). Cylinders shall be complete with pressure-relief valve and associated shut-off valves in good working order. Empty recovery cylinders are evacuated and, if possible, cooled before recovery occurs. The recovery equipment shall be in good working order with a set of instructions concerning the equipment at hand and shall be suitable for the recovery of all appropriate refrigerants including, when applicable, FLAMMABLE REFRIGERANTS.

In addition, a set of calibrated weighing scales shall be available and in good working order. Hoses shall be complete with leak-free disconnect couplings and in good condition. Before using the recovery machine, check

that it is in satisfactory working order, has been properly maintained and that any associated electrical components are sealed to prevent ignition in the event of a refrigerant release. Consult manufacturer if in doubt.

The recovered refrigerant shall be returned to the refrigerant supplier in the correct recovery cylinder, and the relevant waste transfer note arranged. Do not mix refrigerants in recovery units and especially not in cylinders. If compressors or compressor oils are to be removed, ensure that they have been evacuated to an acceptable level to make certain that FLAMMABLE REFRIGERANT does not remain within the lubricant. The evacuation process shall be carried out prior to returning the compressor to the suppliers. Only electric heating to the compressor body shall be employed to accelerate this process. When oil is drained from a system, it shall be carried out safely.

11. WARNING FOR USING R32 REFRIGERANT

- Appliance shall be installed, operated and stored in a room with a floor area larger than 4 m².
- Appliance shall not be installed in an unventilated space, if that space is smaller than 4 m².
- Compliance with national gas regulations shall be observed.
- The appliance shall be stored so as to prevent mechanical damage from occurring.
- Any person who is involved with working on or breaking into a refrigerant circuit should hold a current valid certificate from an industry-accredited assessment authority, which authorizes their competence to handle refrigerants safely in accordance with an industry recognized assessment specification.
- Servicing shall only be performed as recommended by the equipment manufacturer. Maintenance and repair requiring the assistance of other skilled personnel shall be carried out under the supervision of the person competent in the use of flammable refrigerants.
- Please follow the instructions carefully to handle, install, clear, service the air conditioner to avoid any damage or hazard. Flammable Refrigerant R32 is used within air conditioner. When maintaining or disposing the air conditioner, the Refrigerant R32 shall be recovered properly, and shall not discharge to air directly.
- No open fire or device like a switch which may generate spark/arcing shall be around air conditioner to avoid causing ignition of the flammable refrigerant used.
- Please follow the instruction carefully to store or maintain the air conditioner to prevent mechanical damage from occurring.
- Flammable Refrigerant R32 is used in air conditioner. Please follow the instruction carefully to avoid any hazard.

12. Installation & Assembly instructions

- Before installing the appliance, you must read the manual carefully to be aware of safety information and notes.
- Unit refrigerant charge amount: refer to unit name plate marking.
- A leak test must be done after the installation is completed.
- It is required to do a safety inspection before maintaining or repairing an air conditioner using combustible refrigerant in order to ensure that the fire risk is reduced to minimum.
- It is necessary to operate the machine under a controlled procedure in order to ensure that any risk arising from the combustible gas or vapor during the operation is reduced to a minimum.

13. Additional notes:

- 1) Handle the unit gently.
- 2) At least two people are needed to lift the chassis. Do not lift by grasping copper pipes.
- 3) Installation shall be performed only by properly trained or qualified personnel.
- 4) The installation site should be in a well-ventilated location, and is convenient for installation and maintenance.
- 5) The site chosen for installing and maintaining an air conditioner containing R32 refrigerant should be free from open fires, welding, smoking, drying ovens or any other heat source higher than 548°C.
- 6) Ensure the air inlet and outlet of the unit are not surrounded by obstacles or close to any heat source or combustible and/or explosive environment.
- 7) If a refrigerant leak occurs during the installation, all personnel should leave the area until the refrigerant leaks out completely for 15 minutes. If the product is damaged, relocate damaged unit to a maintenance station; it is prohibited to weld the refrigerant pipe or conduct other operations at the user site.

CARE AND CLEANING

Turn off the Unit and disconnect the power supply before cleaning

Indoor / Outdoor Coils

The coils on the unit should be checked regularly. If they are clogged with dirt or soot, they may be professionally cleaned. You will need to remove the unit from the case to inspect the coils because the dirt build-up occurs on the coil face that first contacts the debris.

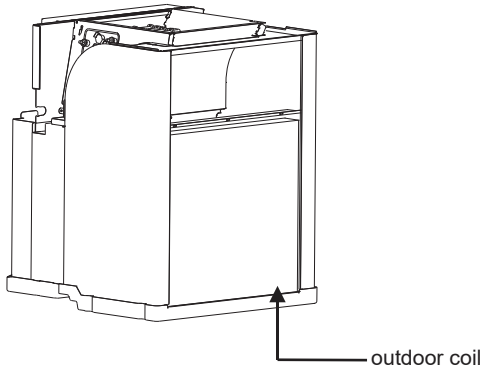

Have the coils been cleaned regularly?

Drain

Clean the drain system regularly to prevent clogging.

Base Pan

In some installations, dirt or other debris may be blown into the unit from the outside and settle in the base pan the bottom of the unit. In some areas of the North America, a "gel-like" substance may be present in the base pan.

Check it periodically and clean, if necessary.

Air Filters

To maintain optimum performance, change the filter at least every 30 days. The most important thing you can do to maintain the unit is to change the filter at least every 30 days. Dirty filters reduce cooling, heating and air flow.

Changing the filter will:

Decrease cost of operation, save energy, prevent clogged heat exchanger coils and reduce the risk of premature component failure.

To remove and replace the filter:

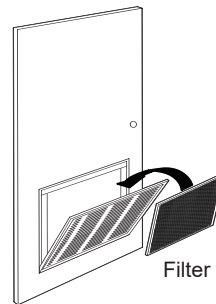
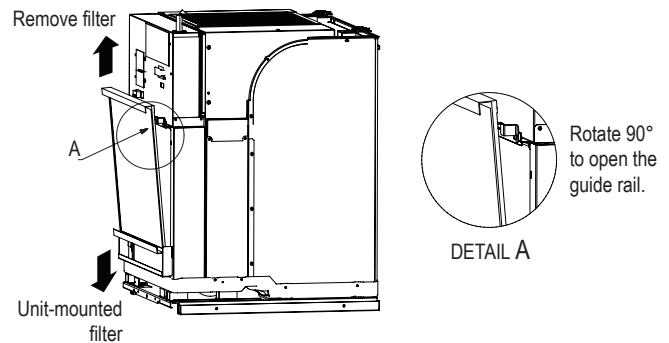

Return air grille with filter holder

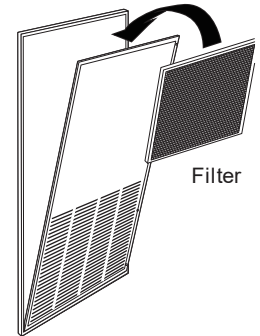

Access-panel with return air grille and filter holder

Operating without the filter in place or with a damaged filter will allow dirt and dust to reach the indoor coil and reduce the cooling, heating airflow and efficiency of the unit.

Replacement filters should be purchased from your local retailer where air conditioner and furnace accessories are sold.

Filter size required is 20 " x 20 " x1 " , except for Access-panel with return air grille and filter holder which requires a 24"x30"x1" size.

NOTICE:

Do not operate the unit without the filter in place. If a filter becomes torn or damaged, it should be replaced immediately.

INSTALLATION INSTRUCTIONS

BEFORE YOU BEGIN

Read these instructions completely and carefully.

IMPORTANT - Save these instructions for local inspector's use.

IMPORTANT - Observe all governing codes and ordinances.

Note to Installer - Be sure to leave these instructions with the owner.

Note to Owner - Keep these instructions for future reference.

Proper installation is the responsibility of the installer.

Product failure due to improper installation is not covered under the Warranty.

You **MUST** use all supplied parts and use proper installation procedures as described in these instructions when installing this air conditioner.

WARNING

RISK OF ELECTRIC SHOCK.

Can cause injury or death. This appliance must be properly grounded. Where a 2-prong wall outlet is encountered, it is your responsibility and obligation to have it replaced with a properly grounded 3-prong outlet.

WARNING

This air conditioner is not meant to provide unattended cooling or life support for persons or animals who are unable reacting to the failure of the product.

The failure or an unattended air conditioner may result in extreme heat in the conditioned space causing overheating or death of persons or animals.

IMPORTANT ELECTRICAL SAFETY-READ CAREFULLY

WARNING

RISK OF ELECTRIC SHOCK.

All electrical connections and wiring **MUST** be installed by a qualified electrician.

Follow the National Electrical Code (NEC) and/or local codes and ordinances.

For personal safety, this unit and case must be properly grounded.

Protective devices (fuses or circuit breakers) acceptable for unit installations are specified on the nameplate of each unit.

Do not use an extension cord with this unit.

Aluminum building wiring may present special problems - consult a qualified electrician.

When the unit is not running there is still voltage to the electrical controls.

Disconnect the power to the unit before servicing by:

1. Removing the power cord (if it has one) from the wall receptacle.

OR

2. Removing the branch circuit fuses or turning the circuit breakers off at the panel.

Electrical Requirement

- **LCDI Cords(230/208V models only)** - Underwriters Laboratories and the National Electric Code (NEC) now require power cords that sense current leakage and can open the electrical circuit to the unit on units rated at 250 volts or less. In the event that unit does not operate, check the reset button located on or near the head of the power cord as part of the normal troubleshooting procedure.

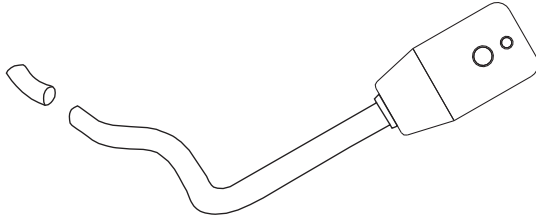

LCDI power Cord

All wiring, including installation of the receptacle, must be in accordance with the NEC and local codes ordinances and regulations.



Tandem
230/208V 15Amp



Perpendicular
230/208V 20Amp



Large tandem
230/208V 30Amp



265V 15Amp



265V 20Amp



265V 30Amp

VOLTAGE MEASUREMENTS

Once the unit is properly wired, measure the unit supply voltage. Voltage must fall within the voltage utilization range.

Operating Voltage		
Unit Voltage	Voltage Utilization Range	
Rating	Minimum	Maximum
230/208	187	253
265	238	292

Models	Small Chassis 12K		Large Chassis 18K	
	Electric Heater(KW)	3.4	5.0	5.0
Power Codes	LCDI (20A)	LCDI (30A)	LCDI (30A)	6AWG
MCA (A)	20	30	30	45
MOP (A)	20	30	30	45

Large chassis models, it is important to have a suitable power supply connected to the device being installed. For more detailed requirements, please refer to the device rating label, wiring diagram and electrical data in the installation instructions. If necessary, install a branch circuit breaker of sufficient size, which is located within sight and easy to install.

! WARNING

To avoid the risk of property damage, personal injury or death due to fire, ensure that the Case, Unit, and Front Case Panel are replaced as a complete assembly in a retrofit/replacement situation. Do not under any circumstances insert this Unit into an existing competitor case. For example, some existing cases may contain plastics that are incompatible with this unit from a safety standpoint.

! WARNING

HIGH VOLTAGE

Disconnect all power before servicing or installing this unit multiple power sources be present, failure to do so may cause property damage, personal injury or death. Do not service this unit without first shutting off the power to the unit from the circuit breaker and/or removing the unit cord set plug from the wall outlet.

! WARNING

To avoid the risk of property damage, personal injury or fire, use only copper conductors.

! WARNING

To avoid property damage, personal injury or death due to electrical shock, do not use an extension cord with this unit.

! WARNING

To avoid the risk of property damage, personal injury or fire do not install with power cord stretched or under a strain as this may create loose plug/receptacle connection.

! WARNING

To avoid the risk of personal injury, wiring to the unit must be properly polarized and grounded.

Typical Utility Closet And Dimensions (FOR REFERENCE ONLY)

UNIT INSTALLED THROUGH FRONT OF CASE

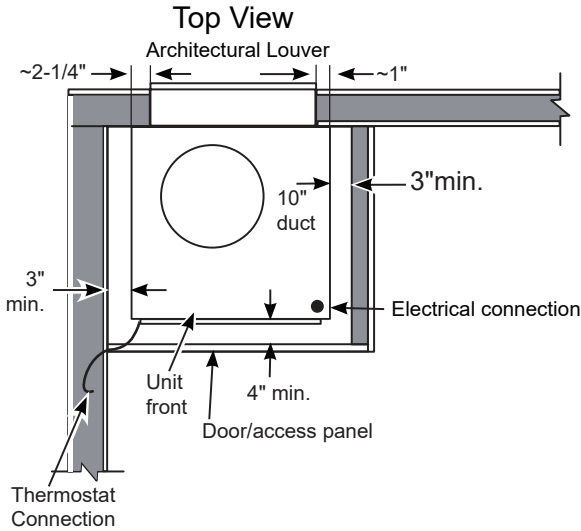

UNIT INSTALLED THROUGH SIDE OF CASE

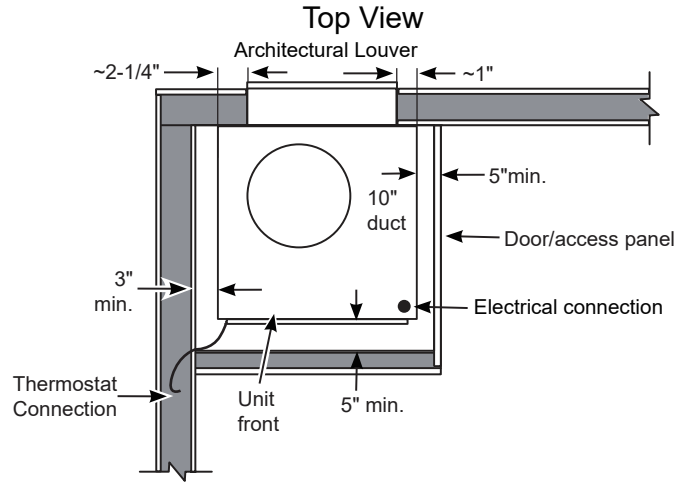

Side View

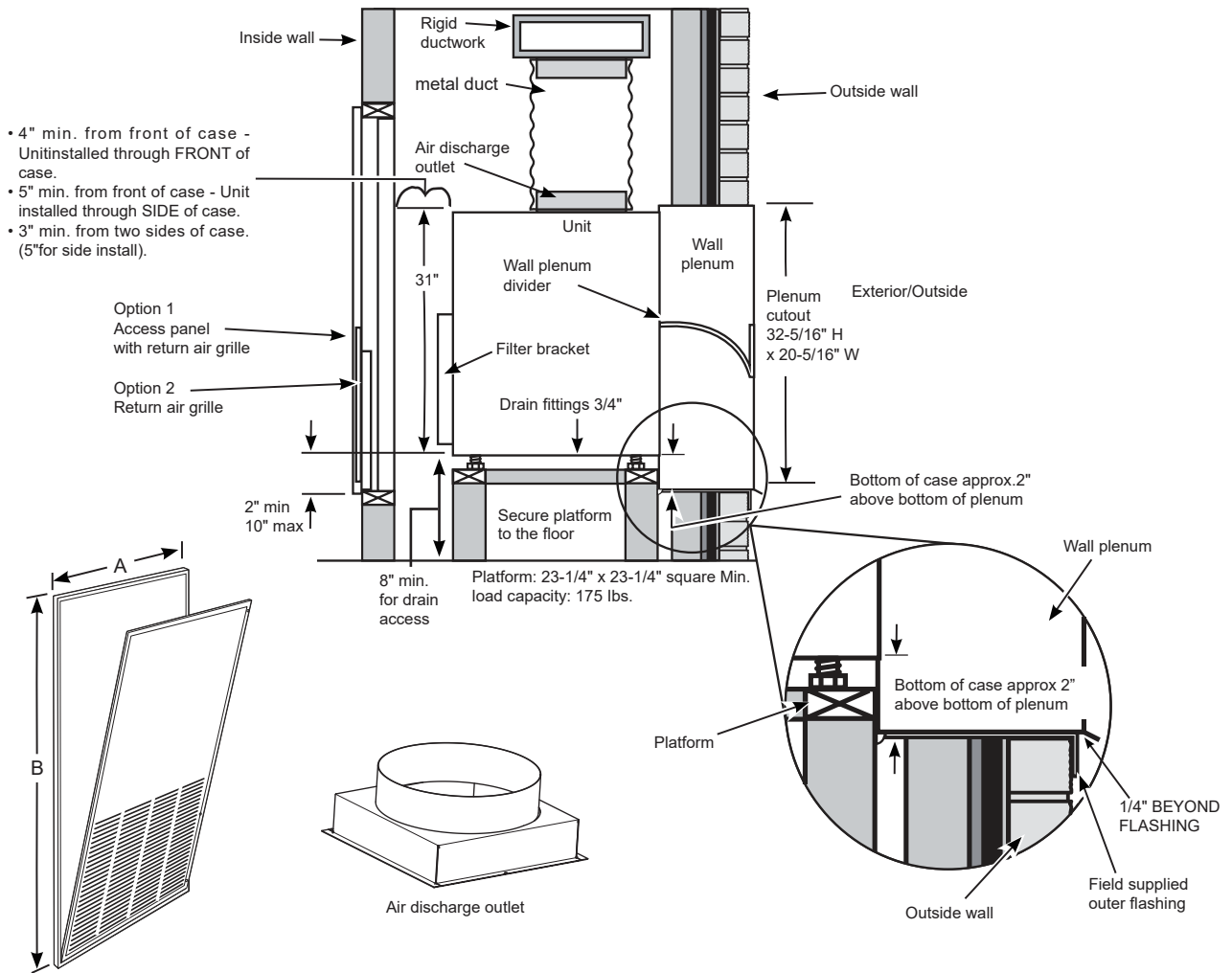

- A Minimum recommended access door width: 30"
- B Minimum recommended access door height : 50"

Utility Closet Connection Locations

IMPORTANT: Plan and locate plenum, wall plug, drains and thermostat carefully to avoid interference. Hard-to-reach locations will make installation and service difficult!

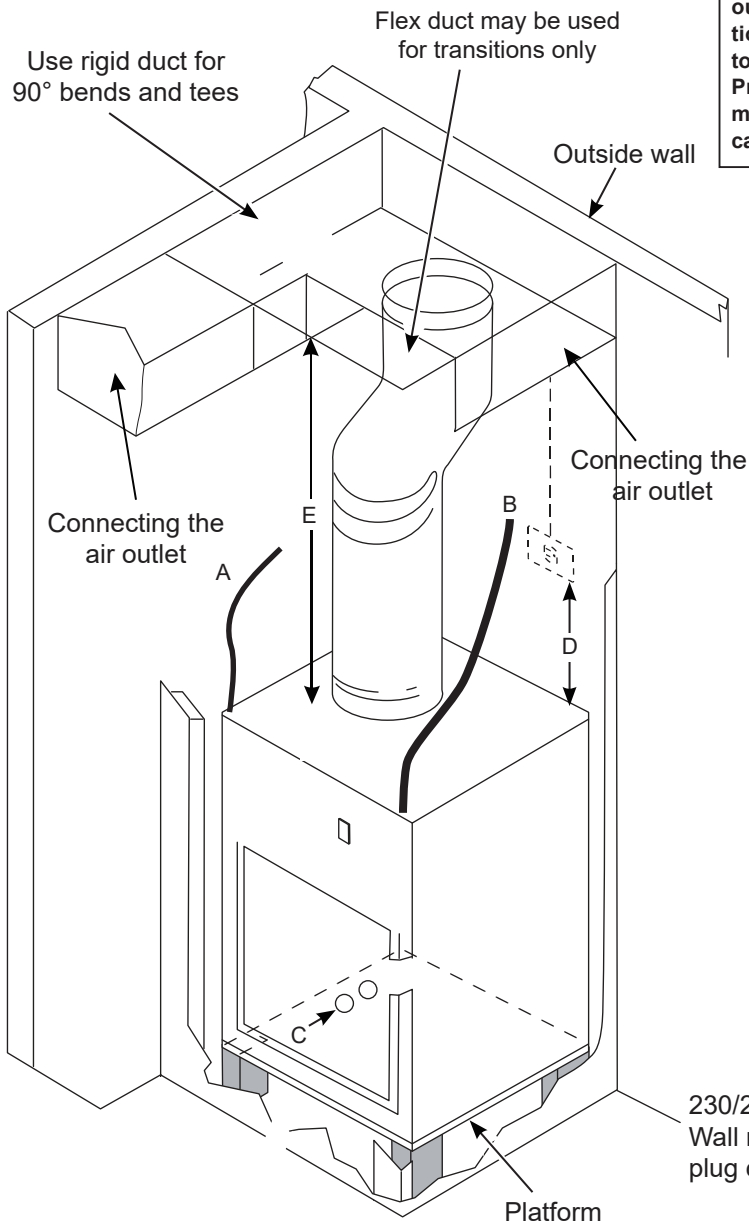

! WARNING

Supply duct is intended to distribute conditioned air throughout a single unit on one floor only. Unit space may be partitioned into rooms within the same unit, but supply air is not to be delivered to any other unit. Provide adequate return air paths for rooms by established means. Do not attach a return air duct to the chassis or outer case.

Reference Dimensions

- A** Thermostat cable
- B** Power cord: 60" long if 230VAC or conduit entrance if 265VAC.
- C** Condensate drains: 3/4" connector
 - Primary Drain - Centerline of cutout is approximately 5-1/4" from left case wall and 8-1/2" from back case wall.
 - Secondary Drain-centerline of cutout is approximately 6-1/2" from left case wall and 5-1/4" from back case wall.
- D** Typical wall plug: 6"-12" above case
- E** 40" min.



Air outlet

! WARNING

To avoid the risk of property damage, personal injury, or death due to fire, use metal duct material only.

Accessories for Small Chassis Unit

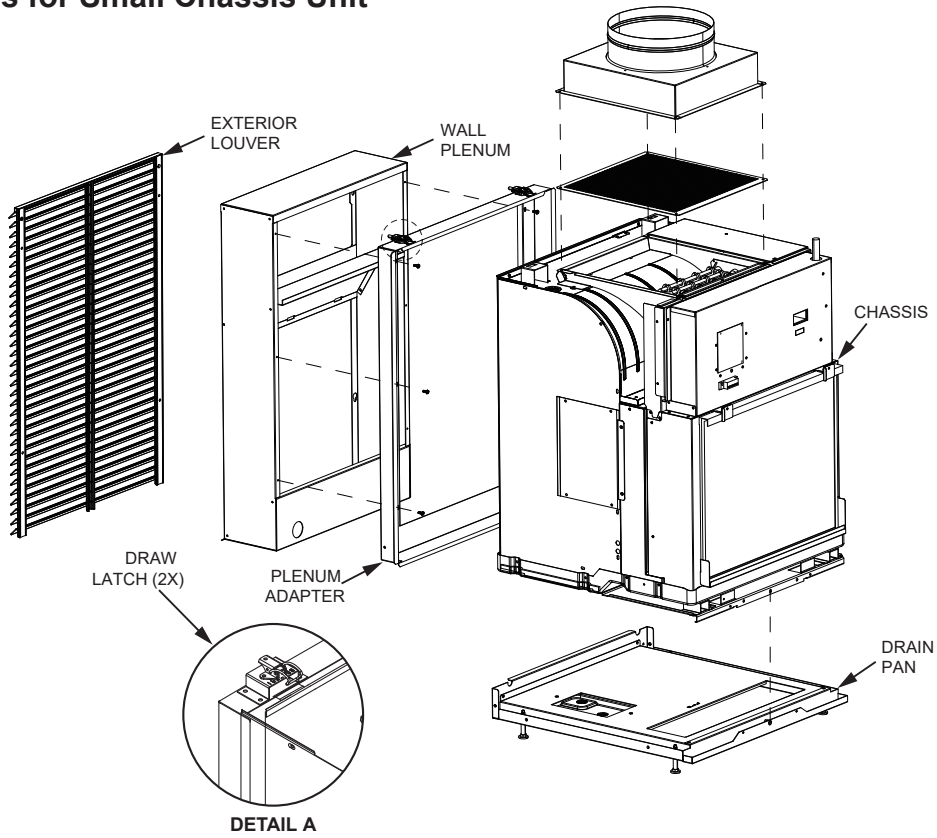

Accessories for Large Chassis Unit

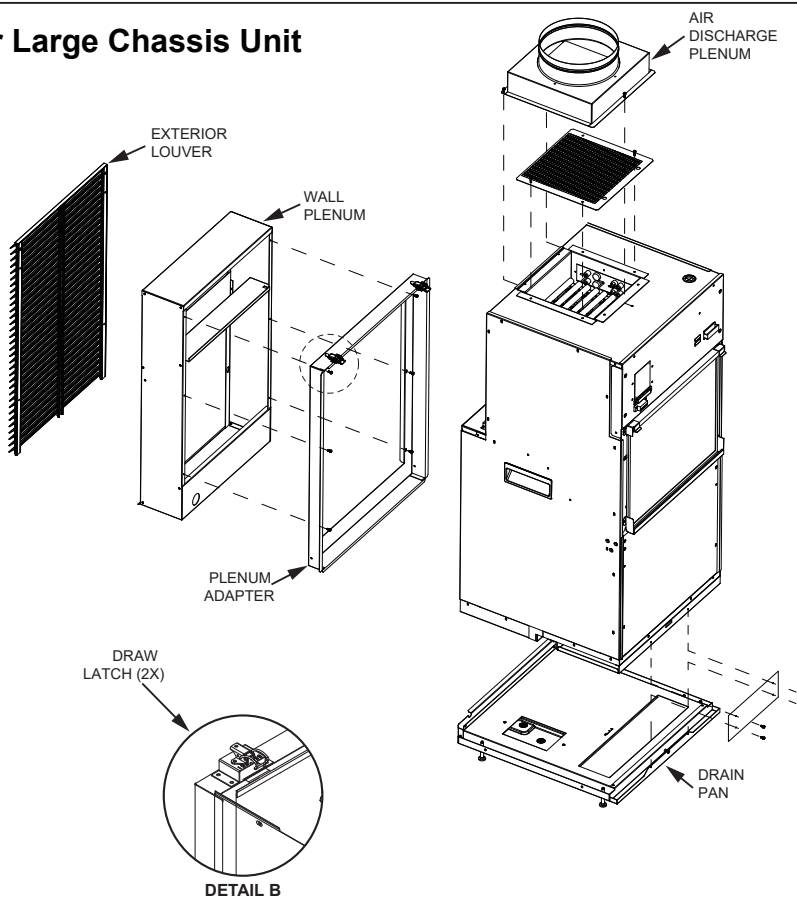

Unit Dimensions

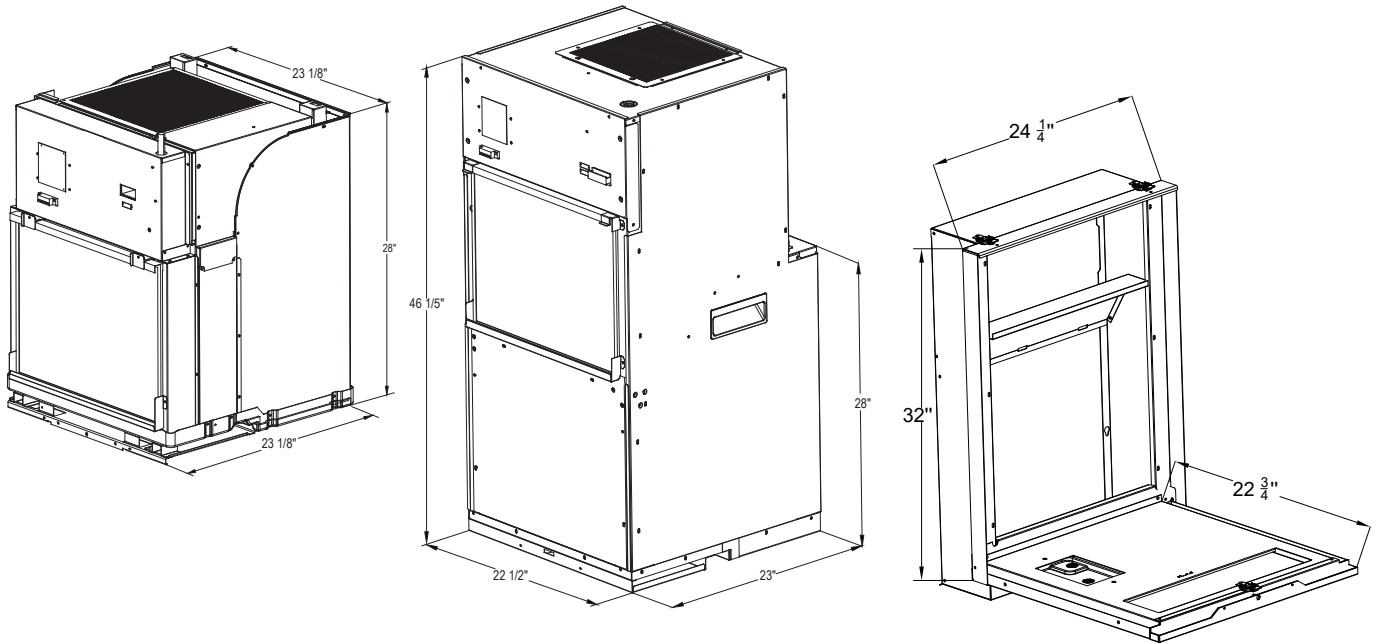

Base Platform Construction

The Space Constrained Products unit requires a field-supplied base platform (having a load-bearing capacity of 230 lb. minimum). For warranty purposes, the base platform must be constructed to ensure the unit chassis can be removed through the access panel.

Proceed as follows:

Space Constrained Products Unit and Base Platform

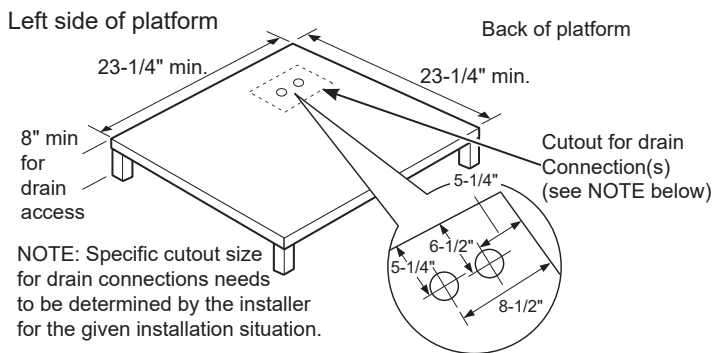

- 1- Construct a 23 1/4" min. × 23 1/4" min. square platform with legs to raise platform a minimum of 8" (12" recommended), see diagram above.
- 2- Make the drain hole cutout (size and location based on installation requirements).
- 3- Place the platform in the utility closet large enough to provide the following clearances between it and the interior surface of the walls/door/panel:

Note: When determining the closet depth, consideration must be given to the fact that the plenum will protrude into the closet because the plenum will be thicker than the exterior wall.

- If Space Constrained Products unit is to be installed through the front of case:
 - 4" minimum clearance from the front of the platform to inside of the closet door, 3" minimum clearance from each side of the case.
 - If Space Constrained Products unit is to be installed through the side of case:
 - 5" minimum clearance from the front of the case, 5" minimum clearance from each side.
- 4- The platform legs must be positioned so access to the unit drain connections are not blocked. Align the platform with the opening of the wall plenum and secure to the floor using appropriate brackets and screws.

Wall Plenum

Since the Space Constrained Products unit itself does not install in the wall opening, the use of a wall plenum is necessary to contain and separate the outdoor air paths to prevent the discharge air from being drawn back into the unit. The plenum must be able to hold water in the bottom without leaking into the wall cavity.

The installation of flashing, with a 45° drip lip, is recommended below the plenum.

The plenum is not loadbearing, so a proper header needs to be installed above the plenum just as over any window opening in the wall. If the building construction is brick, concrete block, or other non self-supporting material, a lintel must be installed over the plenum opening. The plenum is to be installed square and level in the opening and secured to the wall construction with screws or nails in the sides located a minimum of 2 " from the bottom of the plenum. No nails or screws may be used in the bottom or top of the plenum to ensure against water entering the wall cavity. The plenum must be caulked (on all four sides) along the outdoor wall face and along the interior wall to prevent air infiltration and water intrusion.

The wall opening location for the plenum must extend 1 " below the top of the Installation Platform. Since the platform must be a minimum of 8 " off the floor, the cutout for the plenum must be a minimum of 7 " , plus the thickness of the platform base, off the interior finished floor.

We offers four plenum depths; the choice of the correct plenum is determined by the thickness of the building' s exterior wall. Each plenum is 19 7/8 " wide by 32 " high and requires a 20 1/8 " wide by 32 1/4 " high cutout in the wall.

Prepare the closet supply air duct work for later connection to the case. Plenum duct should be insulated to prevent condensation and to reduce air noise.

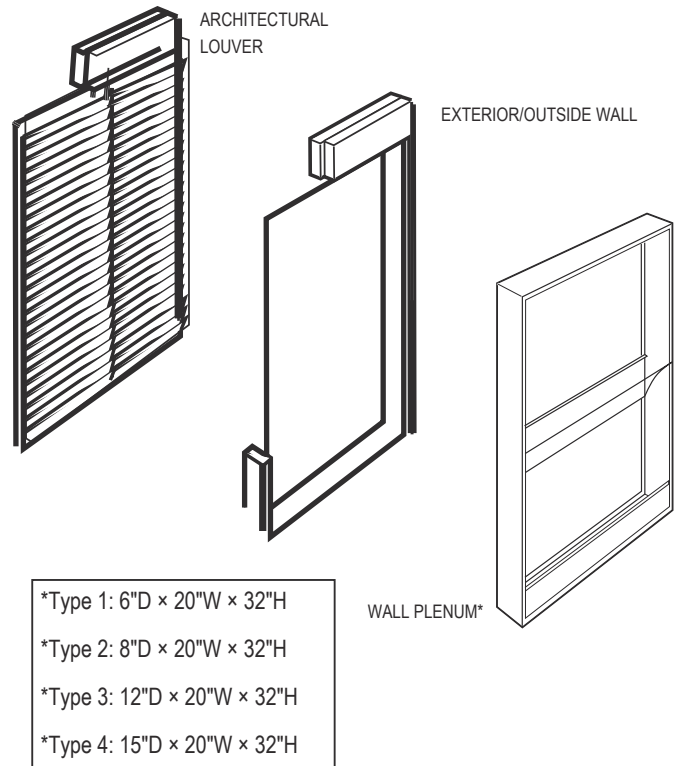

Standard Exterior (Rear) Grille

The standard exterior grille (louver) is mounted to the exterior flange of the plenum and held in place with four screws inserted from inside the enclosure closet. The grille is designed specifically for use with the Space Constrained Products unit and the use of any other grille must be approved by Air Conditioning Applications Engineering.

- 1- Prepare the grille for installation by installing the four plastic fasteners supplied through the holes in the grille.
- 2- Guide the alignment pins, located on the lower right and lower left hand corners of the grille, into corresponding holes on the rear outside edge of the plenum.
- 3- If installing the grille from inside the room, use a plastic wire zip-tie or tie a short length of string or insulated wire around several louvers as a holding device in order to keep a firm grasp on the grille. Angle the grille through the opening at the rear of the plenum, then pull the grille back toward the plenum and align the screw heads with the holes. Be sure to keep a firm grip on the grille to prevent it from dropping and/ or causing possible injury and/ or property damage.
- 4- Secure the grille to the plenum by installing screws into the plastic fasteners. Be careful not to damage fasteners by overtightening. Remove the holding device (plastic wire ziptie, etc.) when installation is complete.

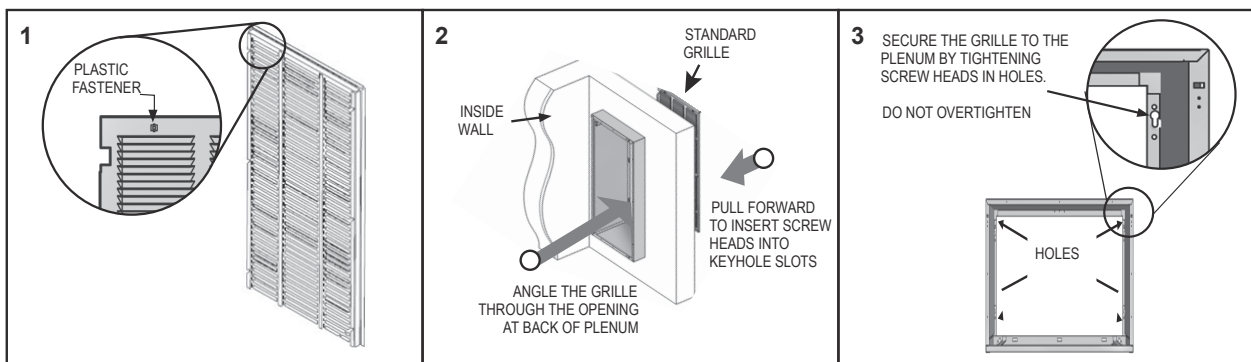

Architectural Exterior (Rear) Grille

The architectural rear grille directs condenser airflow and provides a protective barrier for the outdoor coil. Either the approved Standard or Architectural grille must be installed before installing the chassis.

- 1- Install the four threaded studs into the threaded openings on the inside face of the grille. Install a washer and one hex nut to the end of each stud.
- 2- Manipulate the grille out through the rear plenum opening. Be sure to keep a firm grip on the grille to prevent it from dropping and/ or causing possible injury or property damage.
- 3- Attach the grille to the plenum by aligning and inserting the hex nut threaded onto the studs through the corresponding holes in the plenum.
- 4- Secure grille to the plenum by tightening the hex nut and adding and tightening an additional hex nut.

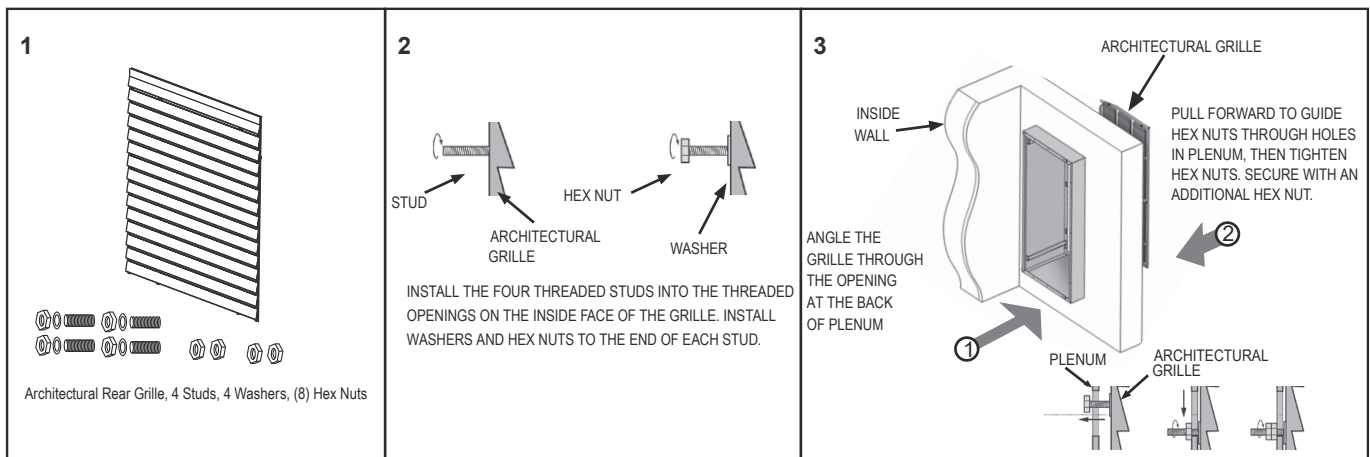

Plenum Adapter / Drain Pan Assembly

The Plenum Adapter and Drain Pan are shipped unassembled and must be attached together prior to installation. When assembling, it is important that an angle of 90 ° is achieved between the upright Plenum Adapter and the horizontal Drain Pan as shown in figured below. This will ensure the two draw latches on the top of the Chassis align properly with their corresponding catches located on the Plenum Adapter.

- 1- With the Plenum Adapter in an upright position, slide the rear end of Drain Pan into the bottom of the Plenum Adapter so the left and right side mounting screw holes are aligned.
- 2- Install two (2) #8 x 3/8" slotted hex screws (supplied) to secure the Drain Pan to the Plenum Adapter. Ensure the angle between the upright Plenum Adapter and the Drain Pan is as close as possible to 90°.

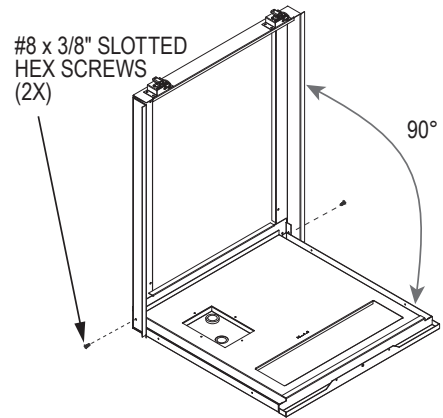
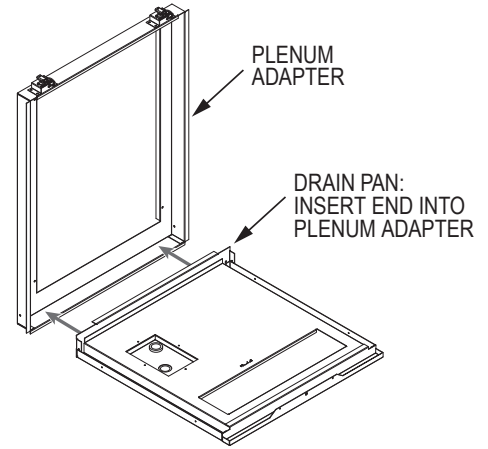

Attaching Drain Pan / Plenum Adapter to Wall Plenum

- 1- Align the screw holes in the Plenum Adapter with the corresponding screw holes in the Wall Plenum.
- 2- Attach the Plenum Adapter to the plenum opening using six (6) field-supplied sheet metal screws (stainless screws recommended).
- 3- Place the Drain Pan/Plenum Adapter onto the Base Platform in the closet with the outdoor side facing the Wall Plenum.
- 4- Place a level on the Drain Pan and adjust the two (2) Leveling Screws so Drain Pan is level in both front-to-back and left-to-right directions.
- 5- Using the indicated holes in the Drain Pan as a guide, drill holes into the base platform. Use four field-supplied bolts, washers and nuts (3/8" dia. recommended) to secure the Drain Pan to the Base Platform. Do not tighten the bolts to the point of distorting the Drain Pan. Failure to properly secure the Drain Pan to the platform may result in excessive unit vibration and increased noise level.

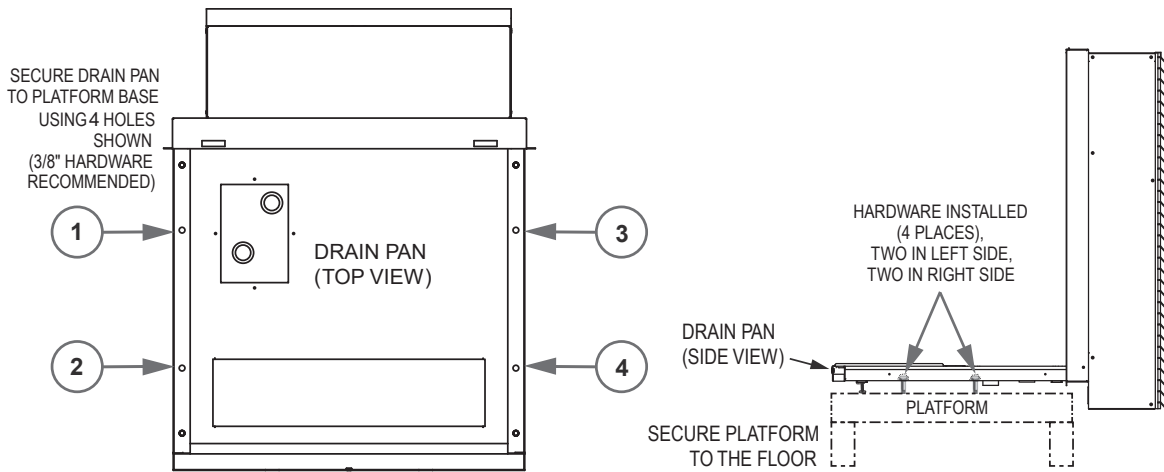
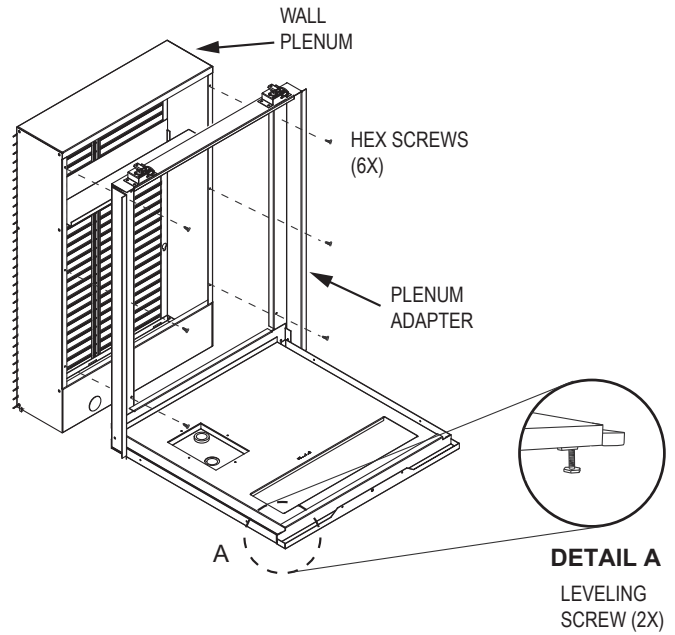

Drain Connection(s)

The Space Constrained Products unit is equipped with a primary and secondary drain fitting. An external or an internal drain pipe must be attached to the primary drain fitting. The secondary drain fitting is provided for connection when required by state and local codes. Refer to local codes for proper installation of the drains.

External Drain: Attach a 90° PVC elbow to the unit's female 3/4" NPT drain fitting. Use the other end of the elbow to run a 3/4" schedule 40 PVC pipe to a P-Trap and then through the knockout hole of the Wall Plenum to the outside. A notch must be cut in the rear grille (louver blade) to allow the tube to pass through. Seal the gap between the Wall Plenum hole and PVC tube.

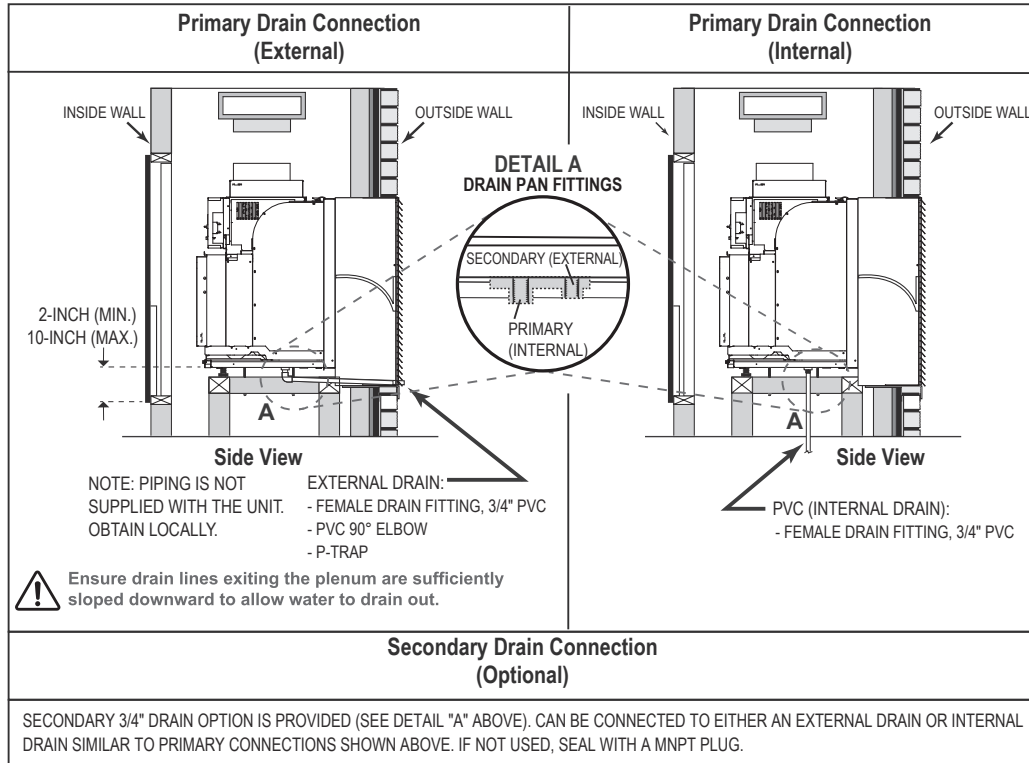

The secondary drain fitting is shipped open (unplugged) and must either be plugged (if not used) or connected to an independent drain system. If a secondary drain system is used, attach a 90° schedule 40 PVC elbow to the secondary drain fitting directed toward the secondary drain system. If a secondary drain system is NOT used, install a 3/4" schedule 40 PVC MNPT plug to cap the hole.

Space Constrained Products Unit (Chassis)

The Space Constrained Products unit is packaged with the case and the front panel in place.

- 1- Place the unit (chassis) on the Drain Pan.
- 2- Install the Wing Bolt through the front of the Drain Pan and hand-tighten into the chassis.
- 3- Align the Plenum Adapter to the chassis (outdoor side) and secure using the two (2) draw latches on the chassis (see figure below).

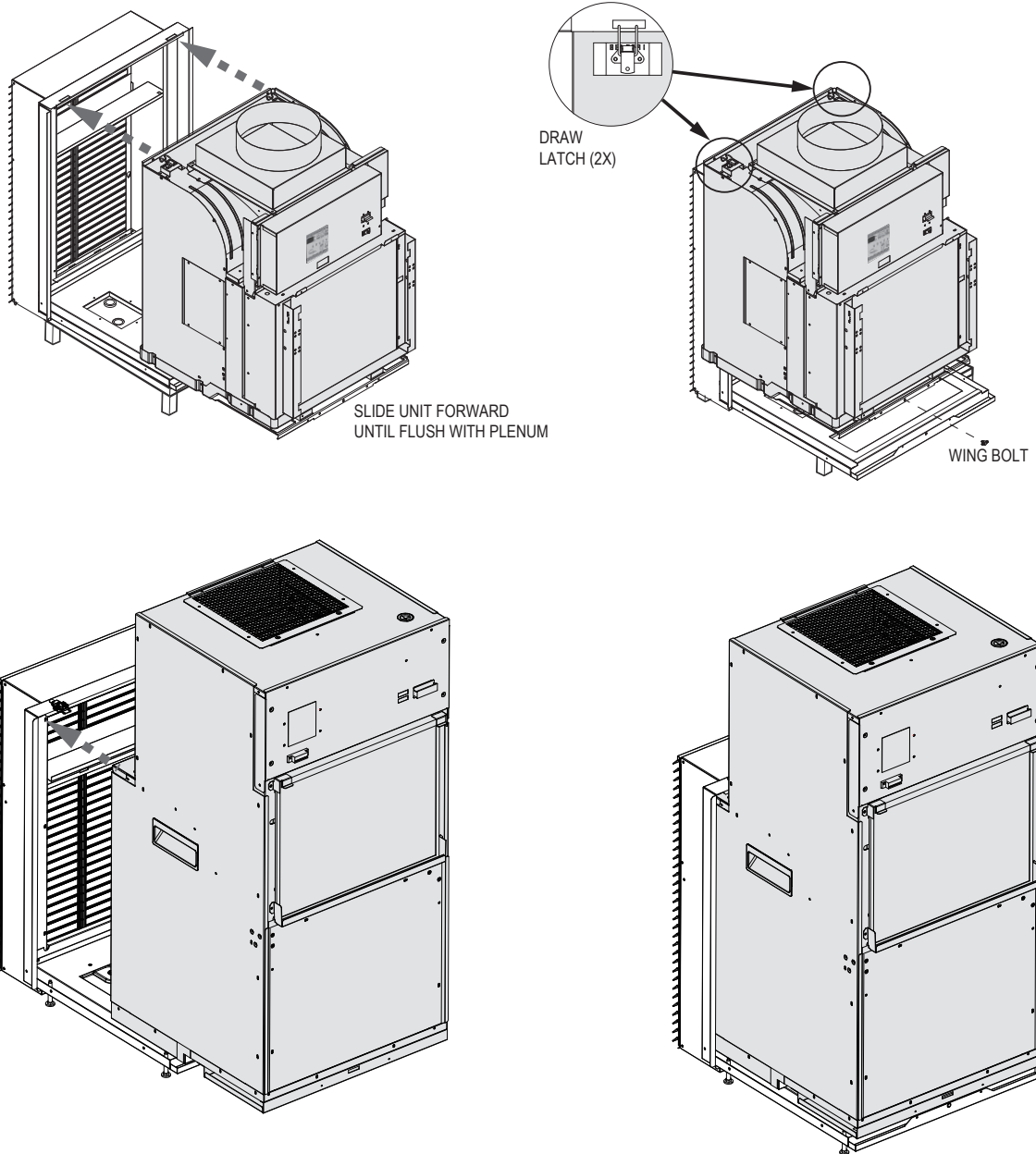

Air Discharge Plenum

The Air Discharge Plenum is shipped separately and requires in the field assembly and installation. Before proceeding, prepare the closet duct work for later connection to the Air Discharge Plenum.

Note: The protective net needs to be removed before installing the Air Discharge Plenum.

- 1- Locate the slot in the mounting flange of the Spin-on Collar. Slip the back edge of the collar mounting flange into the circular hole in the Discharge Plenum and spin the collar around to thread it into the Discharge Plenum.
- 2- Use aluminum tape provided to seal connection between Spin-on Collar and Discharge Plenum.
- 3- Align the front side of the Discharge Plenum (side with label) with the front (return air side) of the unit (chassis).
- 4- Secure Discharge Plenum to the unit using four (4) #8 × 3/8" hex screws supplied with Air Discharge Plenum.

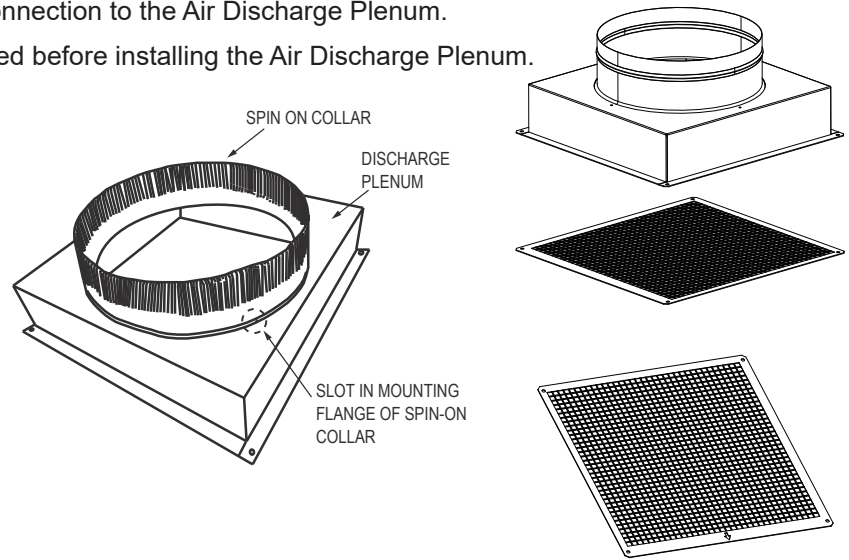

Connect the Top Duct

The collar on top of the Air Discharge Plenum accepts field-supplied, insulated, flexible or rigid 10" diameter transition duct. Flexible duct may be used for transitions only, rigid duct must be used for 90° bends and tees. DO NOT use flex duct for 90° bends or unsupported runs of 5 feet or more (flex duct can collapse and cause airflow restrictions). Pull all duct tight; extra duct slack can greatly increase static pressure.

Carefully attach flexible duct core and insulation/jacket to Air Discharge Plenum using two (2) 36" cable ties provided (one for flexible duct core and one for insulation/jacket).

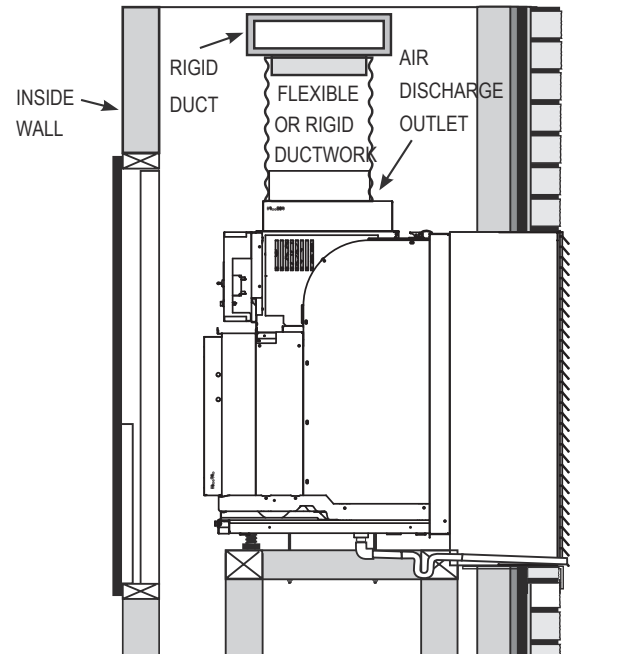

Unit Power Connection

- 1- 230/208v units are equipped with an LCDI power cord that can open the electrical circuit to the unit. In the event the unit does not operate, check the reset button located on or near the head of the LCDI power cord as part of the normal troubleshooting procedure. Make power connections to the unit (refer to WIRING DIAGRAMS section).
- 2- Once the unit is properly wired, measure the unit supply voltage. Voltage must fall within the voltage utilization range shown in the table below.

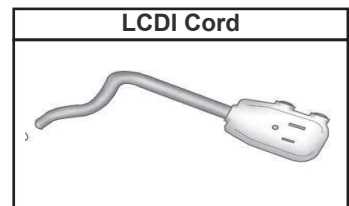

230/208V units with less than 5kW electric heating are equipped with an LCDI power cord that can open the electrical circuit to the unit. In the event the unit does not operate, check the reset button located on or near the head of the LCDI power cord as part of the normal troubleshooting procedure. Make power connections to the unit (refer to WIRING DIAGRAMS section).

230/208V units with more than 7.2kW electric heating are use a HARDWIRE connection.

Hardwire Connection

IMPORTANT: Please read following electrical safety data carefully

WARNING

ELECTRICAL SHOCK AND/OR UNIT OPERATION AND DAMAGE HAZARD

Failure to follow this warning could result in personal injury or death and/or unit operation and damage.

- Installation must be performed in accordance with the requirements of NEC and CEC by authorized personnel only.
- For personal safety, this unit **MUST BE** properly grounded.
- Protective devices (fuse or circuit breakers) acceptable for unit installations are specified on the nameplate of each unit.
- Aluminum building wiring may present special problems — consult a qualified electrician.
- When unit is in STOP position, there is still voltage to electrical controls.
- Disconnect power to unit before servicing by:
 1. Removing power cord (if it has one) from wall receptacle.
 2. Removing branch circuit fuses or turning circuit breakers off at panel.

- 1- Remove the Bushing form wiring crossing hole, see Fig 1.

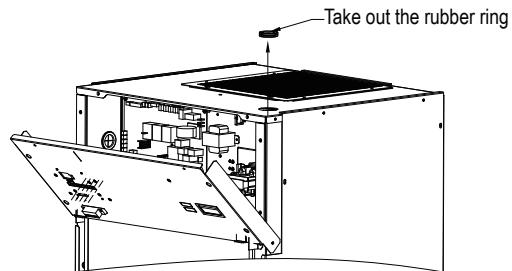

Fig 1

- 2- Connect the external power supply leads and the power supply leads of the machine body with safety wiring cap crimps terminals, see Fig 2 (If the wiring cap are placed outside the machine, they need to be put into the junction box; If the wiring cap are placed inside the machine, junction box is not needed.

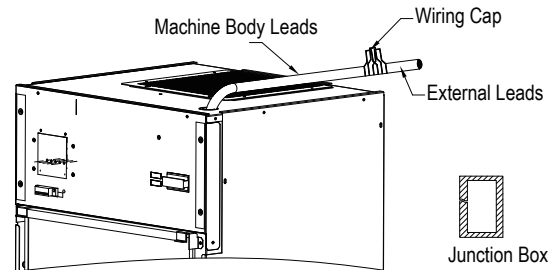

Fig 2

- 3- Pass all the power supply leads into the wire loom tubing, see Fig 3.

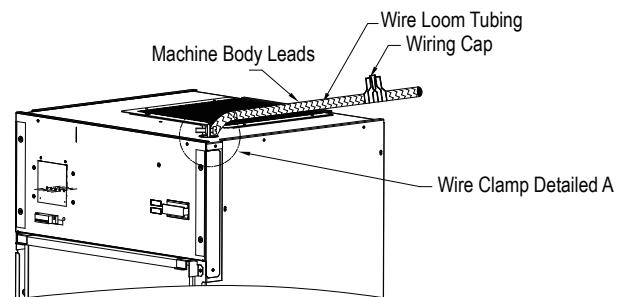

Fig 3

- 4- Lock the wire loom tubing on the electrical installation board with the wire clamp or fix the leads with other fasteners according to the application, see Fig 4.

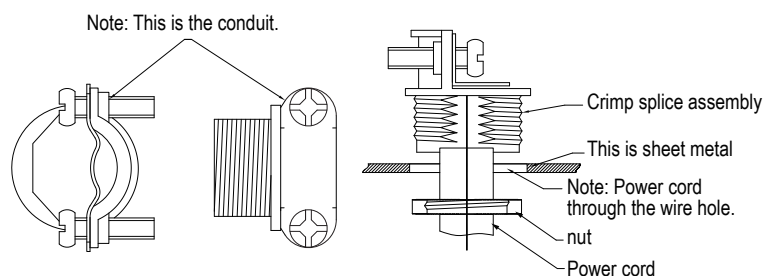

Fig 4 Wire Clamp Detailed A

Remote Wall-Mounted Thermostat

The Space Constrained Products unit can be controlled by any remote electronic thermostat that can interface with RCBWYG terminals. In terms of outputs, there are two types of thermostats: mechanical and solid-state. Refer to the manual provided with the thermostat for proper connections and settings.

A Remote Thermostat Terminal Block with removeable plug is located on the front of the chassis below the touchpad Control Panel. It provides a connection for a remote thermostat and energy management inputs (any type 24 Vac thermostat can be used).

NOTE: Ensure power to the unit is shut off prior to making any electrical connections.

1- Remove the Remote Thermostat Terminal Block plug from the terminal block receptacle and connect the thermostat wires to the plug as shown below.

2- Re-insert plug into terminal block receptacle.

Terminal R

Low voltage terminal to supply voltage to an external wallmounted thermostat. This terminal is capable of supplying 100 mA at 18 - 30 Vac RMS over the entire input voltage range specified.

Terminal GH

When this low-voltage terminal is connected to the R terminal by the thermostat, and the unit is in remote mode, the blower/fan will be requested for operation on high speed.

Terminal B

When this low-voltage terminal is connected to the R terminal by the thermostat, the reversing valve is energized. Electric heat mode shall be attempted automatically if conditions require.

Terminal Y

When this low-voltage terminal is connected to the R terminal by the thermostat, the compressor will be switched on (the GL or GH terminal will also be connected to the R terminal by the thermostat).

Terminal W1

When this low-voltage terminal is connected to the R terminal by the thermostat, electric heat is switched on. Do not use W1 (White) in heat pump applications.

Terminal GL

When this low voltage-terminal is connected to the R terminal by the thermostat, the blower/fan will be requested for operation on low speed.

Terminal C

Low-voltage terminal, 24 Vac common, to provide opposite polarity voltage to the wall-mounted thermostat or RCN.

- **Front Desk Control** — The unit can be turned ON/OFF from a remote location. Front desk control can reduce energy consumption by allowing front desk personnel to turn the unit off when the room is vacant.

Control logic is as below:

1. Turn ON unit: short circuit R and LS for one full second then release for one time within 5 seconds.
2. Turn OFF unit: short circuit R and LS for one full second then release for twice within 5 seconds.

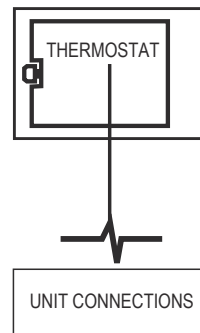
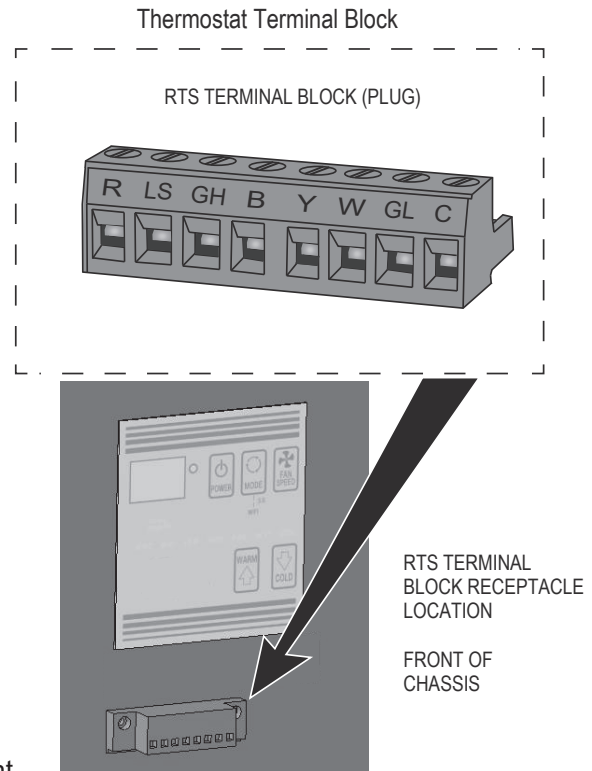

MAXIMUM WIRING LENGTH FOR THERMOSTAT CONNECTION TO UNIT:

66 FT. FOR 18 AWG
60 FT. FOR 20 AWG
(AWG - AMERICAN WIRE GAUGE)

Interior Return Air Grille/Access Panel Configurations

The return air from the room to the Space Constrained Products unit enters the enclosure closet using a return air (see figure). A wall-mounted, front access panel (Item 1) in combination with a wall-mounted, return air grille (Item 2) is required.

- 1- The front access panel requires a 28" wide by 48" high cutout.
- 2- The return air grille is designed to be in-stalled in a 20" wide by 20" high cutout in the wall. An air filter can fit in the bracket located on the front panel of the Space Constrained Products unit.
- 3- A sound-reduction louvered panel that mounts in the door is also available. The soundreduction panel requires a 28" wide by 48" high cutout in the door. The air filter would be installed in the filter bracket located on the front panel of the Space Constrained Products unit.

ITEM 1: The front access panel - must be lined up with the cutout on the Space Constrained Products unit case

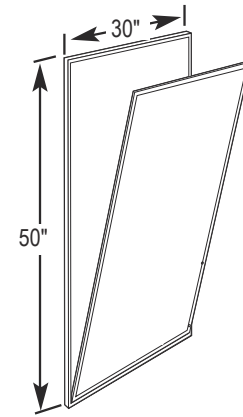

CUTOUT DIMENSIONS
28"W x 48"H

ITEM 2: Return Air Grille

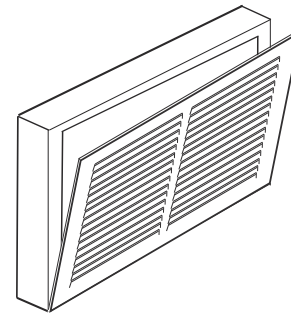

CUTOUT DIMENSIONS
20"W x 20"H (min.)

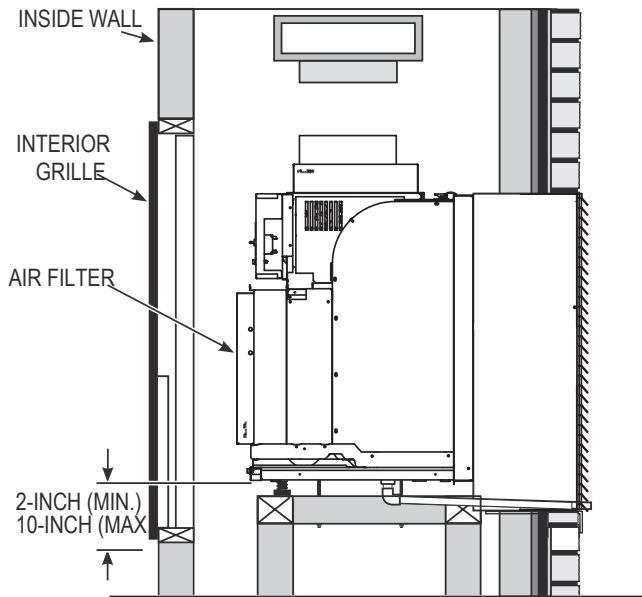

ELECTRICAL WIRING DIAGRAMS

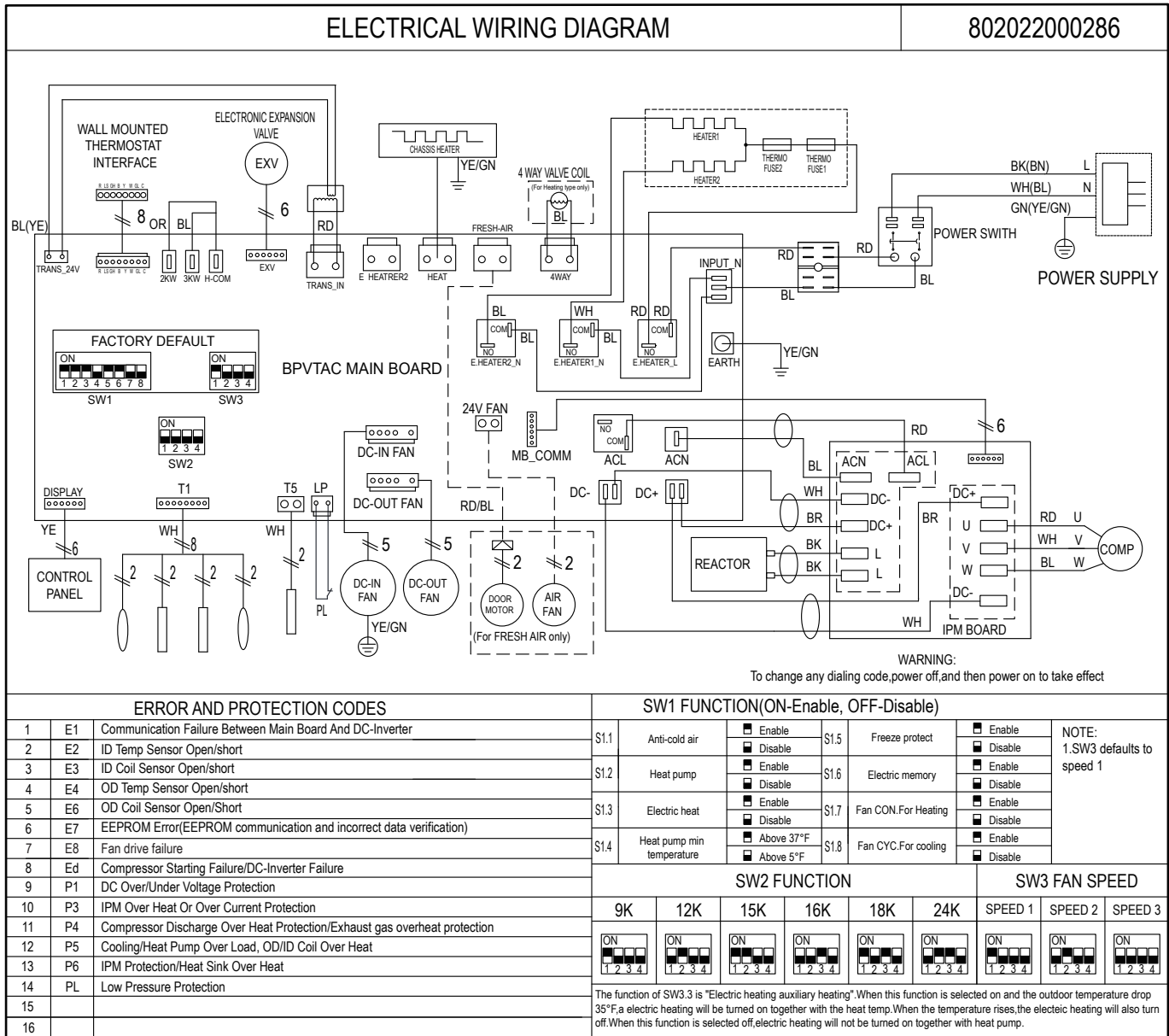

NOTE: Applicable for less than 5kW electric heating. For reference only, the actual wiring diagram shall prevail.

ELECTRICAL WIRING DIAGRAM

802022000285

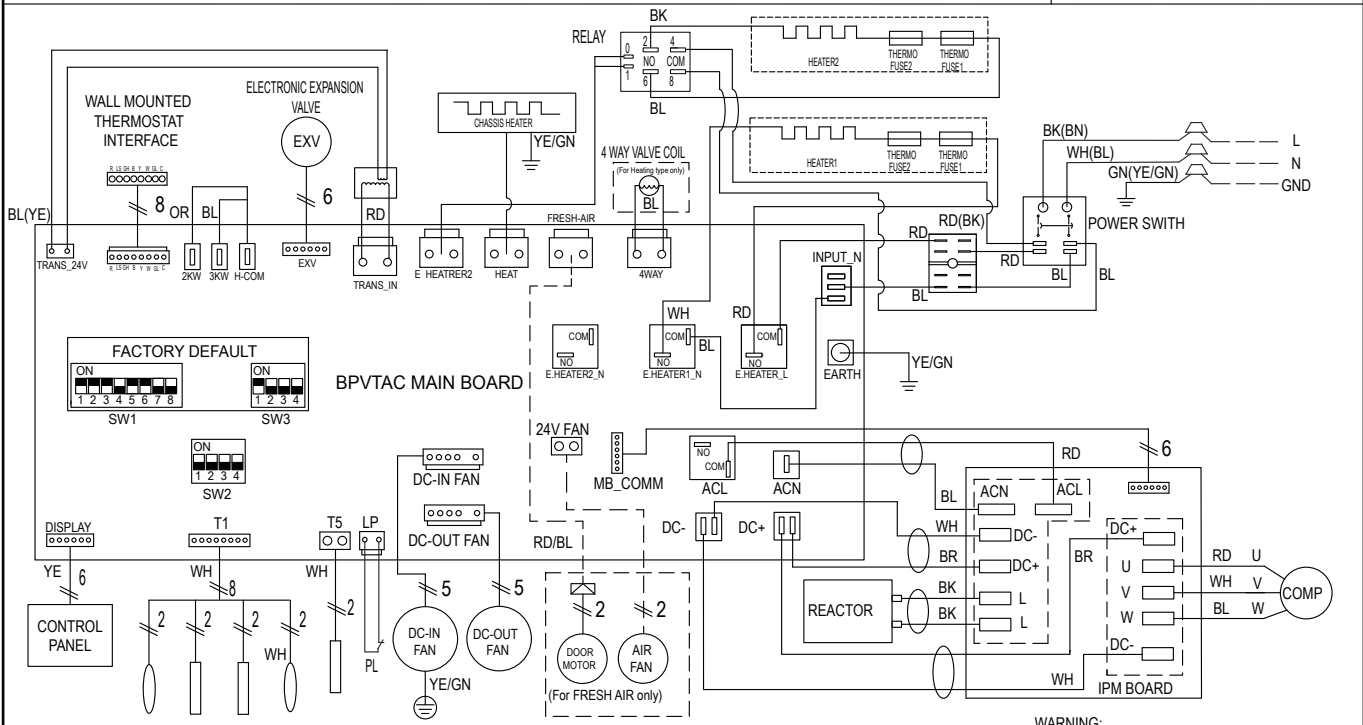

WARNING:
To change any dialing code, power off, and then power on to take effect

ERROR AND PROTECTION CODES			SW1 FUNCTION(ON-Enable, OFF-Disable)								
1	E1	Communication Failure Between Main Board And DC-Inverter	S1.1	Anti-cold air	<input type="checkbox"/> Enable <input type="checkbox"/> Disable	S1.5	Freeze protect	<input type="checkbox"/> Enable <input type="checkbox"/> Disable	NOTE: 1.SW3 defaults to speed 1		
2	E2	ID Temp Sensor Open/short	S1.2	Heat pump	<input type="checkbox"/> Enable <input type="checkbox"/> Disable	S1.6	Electric memory	<input type="checkbox"/> Enable <input type="checkbox"/> Disable			
3	E3	ID Coil Sensor Open/short	S1.3	Electric heat	<input type="checkbox"/> Enable <input type="checkbox"/> Disable	S1.7	Fan CON.For Heating	<input type="checkbox"/> Enable <input type="checkbox"/> Disable			
4	E4	OD Temp Sensor Open/short	S1.4	Heat pump min temperature	<input type="checkbox"/> Above 37°F <input type="checkbox"/> Above 5°F	S1.8	Fan CYC.For cooling	<input type="checkbox"/> Enable <input type="checkbox"/> Disable			
5	E6	OD Coil Sensor Open/Short	SW2 FUNCTION						SW3 FAN SPEED		
6	E7	EEPROM Error(EEPROM communication and incorrect data verification)	9K	12K	15K	16K	18K	24K	SPEED 1	SPEED 2	SPEED 3
7	E8	Fan drive failure									
8	Ed	Compressor Starting Failure/DC-Inverter Failure	The function of SW3.3 is "Electric heating auxiliary heating".When this function is selected on and the outdoor temperature drop 35°F,a electric heating will be turned on together with the heat temp.When the temperature rises,the electric heating will also turn off.When this function is selected off,electric heating will not be turned on together with heat pump.								
9	P1	DC Over/Under Voltage Protection									
10	P3	IPM Over Heat Or Over Current Protection									
11	P4	Compressor Discharge Over Heat Protection/Exhaust gas overheat protection									
12	P5	Cooling/Heat Pump Over Load, OD/ID Coil Over Heat									
13	P6	IPM Protection/Heat Sink Over Heat									
14	PL	Low Pressure Protection									
15											
16											

NOTE: Applicable for more than 7.2kW electric heating. For reference only, the actual wiring diagram shall prevail.

OPERATING INSTRUCTIONS

Start Up Checklist

Note: Units are to be installed and checked for proper function by qualified service personnel ONLY.

Check the following:

- Unit is installed in compliance with all codes and ordinances.
- Circuit breakers and receptacles are correct.
- Filter clean and in place.
- All panels in place.
- Condenser coil inlet and outlet free of obstructions and is sealed to louver.
- Evaporator air inlet and outlet is free from obstructions and properly sealed.
- Control operation OK.
- Owner or operator instructed on control operation and routine maintenance.
- Work area is clean and free of debris.
- The power switch is located on the front of the unit. To turn on the unit, insert the contacts into the switch. To turn off the unit, pull the contacts out of the switch.

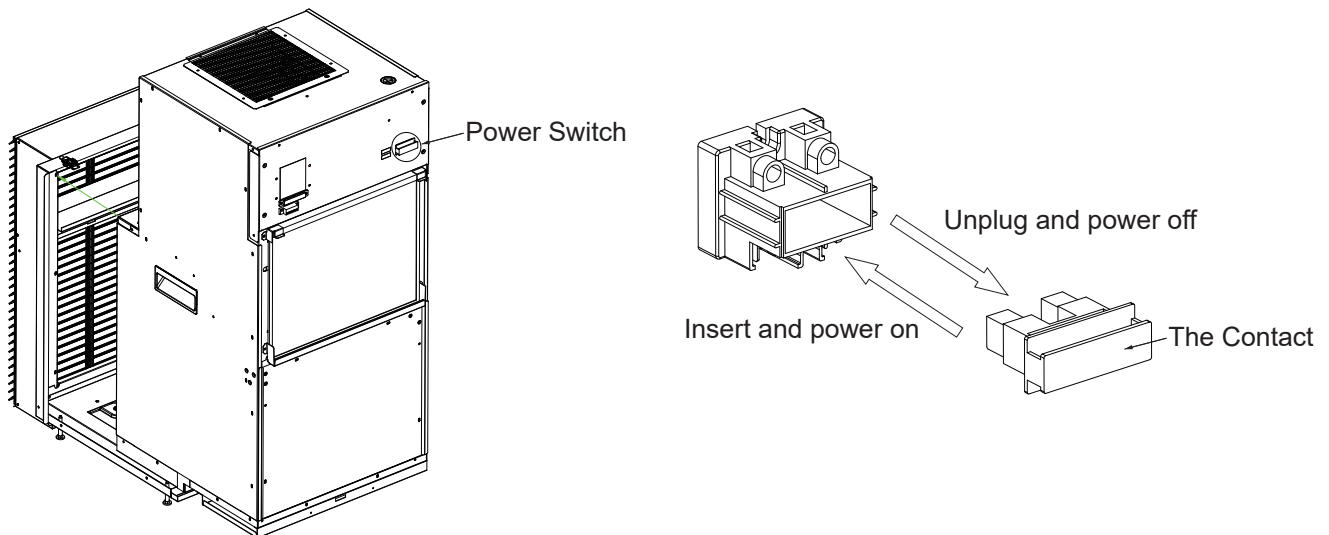

WARNING:

The on/off switch will remove power from the unit. But the power cord terminal is still energized with line voltage and must not be touched. You **MUST DISCONNECT POWER** before repairing or service.

Note: Smoke and odor can occur on initial operation of the heater due to processing residue and/or oil on the heater element. Leave the area serviced by the unit until it is ventilated of any smoke and/or odors by opening doors and windows.

Each unit has 'built-in' tools to assist the technician in the troubleshooting of the entire system. Diagnostic Maintenance provides detailed information on Space Constrained Products control operation and operational status including present modes, failures, airflow restriction warnings, operating temperatures, and past failures.

Switch Setting

1. Switch 1

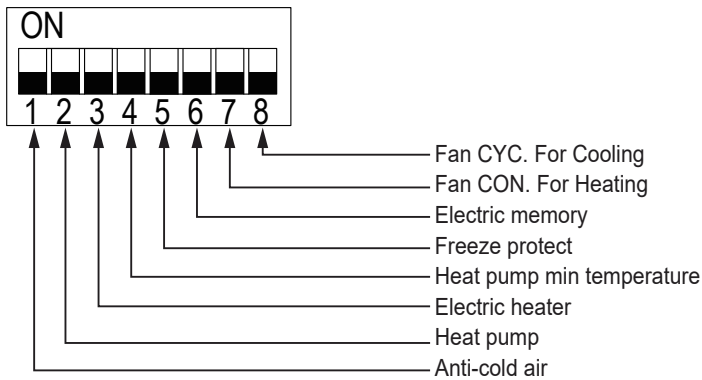

Switch	Description	Function	Factory Setting	Option
1#	Anti-cold air	ON-enable OFF-disable	ON	OFF
2#	Heat pump	ON-enable heat pump; OFF-disable heat pump.	ON	OFF
3#	Electric heater	ON-enable electric heat; OFF-disable electric heat.	ON	OFF
4#	Heat pump min temperature	ON-heat pump min operating temperature is above 37°F OFF-heat pump min operating temperature is above 5°F	OFF	ON
5#	Freeze protect	ON-enable OFF-disable	ON	OFF
6#	Electric memory	ON-enable OFF-disable	ON	OFF
7#	Fan CON. For Heating	ON-enable OFF-disable	OFF	ON
8#	Fan CYC. For Cooling	ON-enable OFF-disable	OFF	ON

SW1.1--Set to ON, the indoor fan speed is automatically adjusted according to the indoor coil temperature. Set to OFF, the indoor fan speed is not affected by the indoor coil temperature.

SW1.2--Set to ON, heat pump enable. When the outdoor temperature is below 5°F, the heat pump will stop working.

SW1.3--Set to ON, electric heat enable. When the outdoor temperature is below 5 degrees, the heating mode is only applicable to electric heating.

SW1.4--Default setting is OFF: the minimum operating temperature of the heat pump is -15°C(5°F). If this switch is put to ON position, the minimum operating temperature of the heat pump is 3°C(37°F).

SW1.5--Works only when SW1.3 is ON. When room temperature is lower than 50°F continuously for 3 minutes, unit will automatically start the electric heating. Only when the room temperature reaches 55°F will heating be stopped.

SW1.6--If the unit cut out of power during the operation, when it is powered up again, all last setting will be remembered, and the operation will follow the last mode. Manual turn on the unit, operation mode will be the last setting.

SW1.7--Default setting is OFF. In heating mode when compressor is OFF, indoor fan will be OFF too(Only valid in operation panel mode).

SW1.8--Default setting is OFF. In cooling mode when compressor is OFF, indoor fan will continuously run. If this switch is put to ON position, when compressor is OFF, indoor fan will be OFF(Only valid in operation panel mode).

2. Switch 2

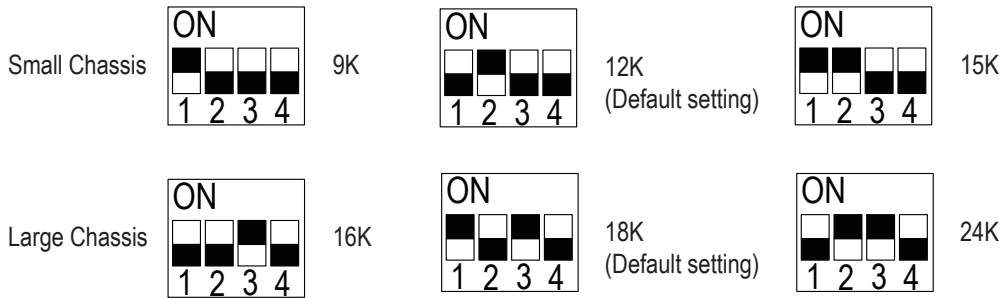
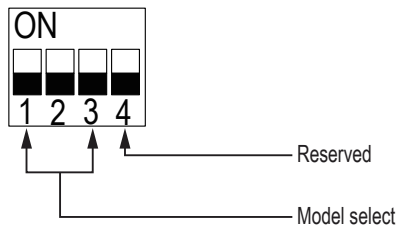

The capacity range of each model are as follows

Model Select		Cooling Capacity Range*	Heating Capacity Range**
Small Chassis	9K	5700~10000	6000~10400
	12K(default)	5700~13000	6000~12700
	15K	7400~15300	7300~14800
Large Chassis	16K	8500~17000	9200~16500
	18K(default)	8600~18600	11000~18700
	24K	10300~22400	11000~20800

*Cooling Capacity tested at Indoor temperature(DB/WB) 80/67°F, outdoor temperature (DB/WB) 95/75°F.

**Heating Capacity tested at Indoor temperature(DB/WB) 70/60°F, outdoor temperature (DB/WB) 47/43°F.

All data were tested at 0.3in ESP.

3. Switch 3

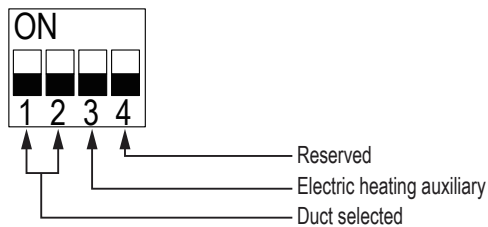

Duct selected

The duct select function allows the indoor fan to be operated at 3 variable fan speeds, the default setting is fan speed 1. Fan speeds selection is as follows:

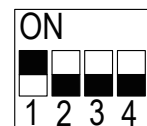

FAN SPEED 1

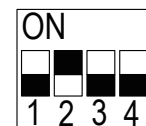

FAN SPEED 2



FAN SPEED 3

COOLING MODE CFM		FAN SPEED 3		FAN SPEED 2		FAN SPEED 1	
Model	ESP	Hi	Lo	Hi	Lo	Hi	Lo
9K/12K	0.00	630	560	560	495	465	430
	0.05	605	525	525	465	435	385
	0.10	580	495	495	430	390	335
	0.15	545	455	455	390	315	255
	0.20	510	385	385	310	--	--
	0.25	425	320	320	250	--	--
	0.30	390	290	290	225	--	--
15K	0.00	665	615	590	545	495	445
	0.05	640	585	560	510	465	405
	0.10	610	555	530	480	430	360
	0.15	585	525	495	440	390	280
	0.20	550	490	440	365	--	--
	0.25	480	415	365	305	--	--
	0.30	440	365	330	275	--	--
16K	0.00	850	815	780	745	695	650
	0.05	820	780	745	705	685	615
	0.10	790	745	715	665	620	575
	0.15	755	715	675	620	575	520
	0.20	720	670	635	570	530	460
	0.25	685	635	590	520	445	365
	0.30	635	590	525	450	365	300
18K	0.00	885	850	815	780	745	695
	0.05	860	820	780	745	705	685
	0.10	820	790	745	715	665	620
	0.15	785	755	715	675	620	575
	0.20	745	720	670	635	570	530
	0.25	705	685	635	590	520	445
	0.30	675	635	590	525	450	365
24K	0.00	935	850	885	780	815	695
	0.05	900	820	860	745	780	685
	0.10	870	790	820	715	745	620
	0.15	840	755	785	675	715	575
	0.20	795	720	745	635	670	530
	0.25	760	685	705	590	635	445
	0.30	720	635	675	525	590	365

HEATING MODE CFM		FAN SPEED 3		FAN SPEED 2		FAN SPEED 1	
Model	ESP	Hi	Lo	Hi	Lo	Hi	Lo
9K/12K	0.00	615	560	545	495	465	430
	0.05	585	525	510	465	435	385
	0.10	555	495	480	430	390	335
	0.15	525	455	440	390	315	255
	0.20	490	385	365	310	--	--
	0.25	415	320	305	250	--	--
	0.30	365	290	275	225	--	--
15K	0.00	665	615	590	545	490	445
	0.05	640	585	560	510	460	405
	0.10	610	555	530	480	420	360
	0.15	585	525	495	440	360	280
	0.20	550	490	440	365	--	--
	0.25	480	415	365	305	--	--
	0.30	440	365	330	275	--	--
16K	0.00	850	815	780	745	695	650
	0.05	820	780	745	705	685	615
	0.10	790	745	715	665	620	575
	0.15	755	715	675	620	575	520
	0.20	720	670	635	570	530	460
	0.25	685	635	590	520	445	365
	0.30	635	590	525	450	365	300
18K	0.00	885	850	815	780	745	695
	0.05	860	820	780	745	705	685
	0.10	820	790	745	715	665	620
	0.15	785	755	715	675	620	575
	0.20	745	720	670	635	570	530
	0.25	705	685	635	590	520	445
	0.30	675	635	590	525	450	365
24K	0.00	915	850	845	780	780	695
	0.05	885	820	810	745	745	685
	0.10	855	790	780	715	715	620
	0.15	820	755	745	675	675	575
	0.20	785	720	705	635	635	530
	0.25	750	685	670	590	590	445
	0.30	710	635	625	525	525	365

Your airflow should be balanced based on many factors such as available ESP room CFM, and ductwork. Consult an HVAC engineer for proper applications. External static pressure (ESP) can be measured with a manometer or pitot tube. Once this ESP is established you can calculate the CFM use above chart.

Electric heating auxiliary

When switch 3.3 is setted in the up position(ON) and the outdoor temperature drop below 35°F, a electric heating will be turned on together with the heat pump. When the indoor temperature rises, the electric heating will also turn off. When switch 3.3 is setted in the down position(OFF), electric heating will not be turned on together with heat pump.

The electric heating enabled by this function is as follows:

Electric Heater(kW)	Turn on
3.4kW(2.5+0.9)	0.9kW
5kW(3+2)	2kW
7.2kW(5+2.2)	2.2kW

Only when SW1.2 and SW1.3 are selected on this function is in effect.

Control Panel Mode Setting

Factory default: 24V thermostat mode.

If the unit needs to operate with the control panel, the operation mode should be selected control panel mode at SENIOR OPERATION.

Under OFF mode, press **[MODE]** and **[FAN SPEED]** buttons at the same time continuously for 5 seconds. This time display 'd0', indicates that system has entered the senior operation status.

The **[MODE]** button is used to switch parameter codes and parameter values.

The **[WARM]** and **[COLD]** buttons are used to switch parameter codes or set parameter values.

The **[ON/OFF]** button is used to save and exit setting.

The following table shows the senior operation functions and setting parameters:

Parameter code	Function	Parameter value	Explanation
d0	Temperature unit selection	F	Fahrenheit(default)
		C	Celsius
d1	Mode of operation selection	P	Unit is operated with control panel
		r	Unit is operated with 24V universal remote thermostat
d2	Setting temperature higher limit	22°C/°F to 32°C/90°F	Setting temperature range: 72°F to 90°F(22°C to 32°C) default value: 32°C/90°F
d3	Setting temperature lower limit	16°C/60°F to 22°C/°F	Setting temperature range: 60°F to 72°F(16°C to 22°C) default value: 16°C/60°F
d4	Indoor temperature true calibration	-9°C to 9°C	If temperature nint is changed, calibrantion should be done again. If use the default value, it can be ignored. (default 0°C/0°F)
		-9°F to 9°F	
d5	Temperature display selection	0 or 1	Select 1: Display room temperature
			Select 0: Display setpoint temperature

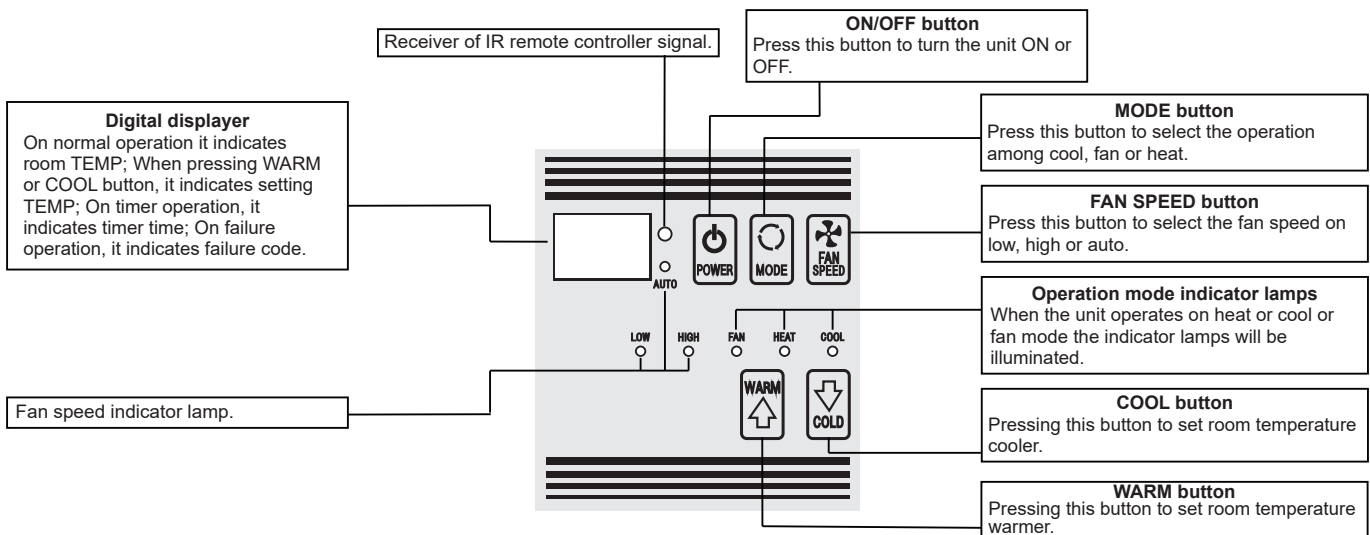

ERROR CODE AND SOLUTIONS

The meaning of each failure code that may appear on the display is described in the table below:

Error Code	Meaning	Solutions
E1	Communication failure between indoor unit and outdoor unit	Check the communication cables, make sure they are firmly connected. If the cables are broken, replace them.
E2	Indoor Temp Sensor Open/Short	Check the plug is firmly connected. If the sensor is broken, replace it.
E3	Indoor Coil Sensor Open/Short	Check the plug is firmly connected. If the sensor is broken, replace it.
E4	Outdoor Temp Sensor Open/Short	Check the plug is firmly connected. If the sensor is broken, replace it.
E6	Outdoor Coil Sensor Open/Short	Check the plug is firmly connected. If the sensor is broken, replace it.
E7	EEPROM Error	Update EEPROM program. If still not resolved, replace the main board.
E8	Main board failure/Fan failure	Check the motor wiring is correct. If the connections are correct, check whether the motor is running properly. If the motor does not work properly, replace the motor. If the motor is running normally, then replace the main board.
Ed	Compressor Fail Starting/DC-Inverter Fail	1.Check DIP switch SW2 on the main board is correctly matched with the unit capacity, refer to the wiring diagram. 2.Make sure the compressor power cord is firmly and correctly connected.
P1	DC Over/Under Voltage Protection	Make sure the power supply is within the requirement (208/230Vac, -10%+10%).
P3	IPM Over Heat or Over Current Protection	1.Make sure indoor and outdoor unit vents are not blocked. 2.Check DIP switch SW2 on the main board is correctly match with the unit capacity, refer to the wiring diagram. Make sure the compressor power cord is firmly and correctly connected.
P4	Compressor Discharge Over Heat Protection	1.Make sure indoor and outdoor unit vents are not blocked. 2.Check DIP switch SW2 on the main board is correctly match with the unit capacity, refer to the wiring diagram. 3.Check if the unit refrigerant is leaking. If so, replenish the refrigerant.
P5	Cooling/Heat Pump Over Load, Outdoor/Indoor Coil Over Heat	Make sure indoor and outdoor unit vents are not blocked. Clear the air filter and the condenser after extended use.
P6	IPM(DC-INVERTER) Protection (Include Heat sink Over Heat)	1.Check the wiring of compressor to the IPM(U/V/W) terminals are correctly connected. Wrong phase connection is not allowed. 2.Remove obstacles in the air path that resists heat interchange.
PL	Low Pressure Protection	1.Check if the unit refrigerant is leaking. If so, replenish the refrigerant. 2.Check the EXV plug, make sure the wire connections are OK.

NORMAL OPERATING SOUNDS AND CONDITIONS

Water trickling sounds

Water is picked up and distributed over the outdoor coil. This improves the efficiency and helps with water removal.

Water dripping

Water will collect in the base pan during high humidity days. This can cause overflow and drip from the outside of the unit if the external instead of internal drain connection method is used.

Air sounds

The fan cycle switch sets the operational mode of the fan. In the ON position the fan will run continuously whenever power is applied in this mode. In the AUTO position, the fan will cycle on and off with the compressor or electric heater.

Starting delay

You may notice a few minutes delay in the starting if you try to restart the unit too soon after turning it off or if you adjust the thermostat right after the compressor has shut off. This is due to a built-in delay to protect the compressor.

Buzzer Response

The buzzer will chime Di" (0.1 sec)as response when receiving the effective order from key pad control.

TROUBLESHOOTING GUIDE

POSSIBLE CAUSES	SOLUTIONS
<p>UNIT DOES NOT START</p> <ul style="list-style-type: none"> • Unit may have become unplugged • Fuse may have blown • Circuit breaker may have been tripped • Unit may be off or in wall thermostat mode. Check section on dipswitch settings to verify dipswitches are set properly. • Unit may be in a protection or diagnostic failure mode. See section on diagnostic codes. 	<ul style="list-style-type: none"> • Check that plug is plugged securely in wall receptacle. Note: Plug has a test/reset button on it. Make sure that the plug has not tripped. • Replace the fuse. • Reset circuit breaker. • Turn unit on (bottom right button on keypad).
<p>DISPLAY HAS STRANGE NUMBERS/CHARACTERS ON IT</p>	<ul style="list-style-type: none"> • The unit may be in a diagnostic condition. Check diagnostic codes --- checking Control section to determine if unit has had a failure. • The unit may be set for °C (instead of °F), see the keypad configuration section.
<p>UNIT MAKING NOISES</p>	<ul style="list-style-type: none"> • Clicking, gurgling and whooshing noises are normal during operation of unit.
<p>UNIT NOT COOLING / HEATING ROOM</p> <ul style="list-style-type: none"> • Unit air discharge section is blocked. • Temperature setting is not high or low enough. Note: Setpoint limits may not allow the unit to heat or cool the room to the temperature desired. Check section on dipswitch settings. • Unit air filters are dirty. • Room is excessively hot or cold when unit is started. • Vent door left open. • Unit may be in a protection or diagnostic failure mode. Check section on Intelligent Self --- checking Control. • Compressor is in time delay. There is a protective time delay (approx. 3 minutes) on starting the compressor after a power outage (or restarting after it has been turned off), to prevent tripping of the compressor overload. 	<ul style="list-style-type: none"> • Make sure that curtains, blinds or furniture are not restricting or blocking unit airflow. • Reset to a lower or higher temperature setting. • Remove and clean filters. • Allow sufficient amount of time for unit to heat or cool the room. Start heating or cooling early before outdoor temperature, cooking heat or gatherings of people make room uncomfortable. • Close vent door. • Check dipswitch settings for desired comfort. • Wait approximately 3 minutes for compressor to start.
<p>WATER DRIPPING OUTSIDE</p>	<ul style="list-style-type: none"> • If a drain kit has not been installed, condensation runoff during very hot and humid weather is normal. See Note 2. If a drain kit has been installed and is connected to a drain system, check gaskets and fittings around drain for leaks and plugs.
<p>WATER DRIPPING INSIDE</p> <ul style="list-style-type: none"> • Wall sleeve is not installed level 	<ul style="list-style-type: none"> • Wall sleeve must be installed level for proper drainage of condensation. Check that installation is level and make any necessary adjustments.
<p>ICE OR FROST FORMS ON INDOOR COIL</p> <ul style="list-style-type: none"> • Low outdoor temperature • Dirty filters 	<ul style="list-style-type: none"> • When outdoor temperature is approximately 55°F (12.8°C) or below, frost may form on the indoor coil when unit is in Cooling mode. Switch unit to FAN operation until ice or frost melts. • Remove and clean filters.
<p>COMPRESSOR PROTECTION</p> <ul style="list-style-type: none"> • Power may have cycled, so compressor is in a restart protection. 	<ul style="list-style-type: none"> • Random Compressor restart — Whenever the unit is plugged in, or power has been restarted, a random compressor restart will occur. After a power outage, the compressor will restart after approximately 3 minutes. • Compressor Protection — To prevent short cycling of the compressor, there is a random startup delay of 3 minutes and a minimum compressor run time of 3 minutes.

802022000303 V0