



TECHNICAL SPECIFICATION

PORTAFILL MR-6



* All drawings dimensions approximate and in millimetres and feet and inches. Portafill International reserves the right to alter the specification of the machines without notice. Images may show some optional equipment. E & OE.

SCREEN BOX

| | |
|--------------------------------|--|
| Screen Box Type | Bolted, 2 Deck, 2 Bearing, High Speed, High Vibration Screen |
| Overall Screen Box Size | 3900mm (12'10") x 1300mm (4'3") |
| Maximum Feed Size | 400mm (depending on material) |
| Mesh Fixing | Optional side or end tensioned top deck screen |

FEEDER CONVEYOR / HOPPER

| | |
|------------------------------|---|
| Feeder Conveyor Width | 1000mm (40") |
| Feeder Conveyor Speed | Variable Speed |
| Hopper Sides | Hydraulically lowering hopper sides for feeding and transport |
| Hopper Volume | 7m ³ (Heaped Approx.) |

WING CONVEYOR MID SIZE / FINES

| | |
|------------------------------------|--|
| Belt Width | 800mm (32") Wide Chevron Belt |
| Discharge Height on Midsize | 3620mm (11'10") |
| Discharge Height on Fines | 3775mm (12'4") |
| Belt Speed | Variable Speed (midsize), Fixed Speed (fines) |
| Design | Honeycomb construction with hydraulic pipes inside wing conveyor |

TRANSFER BELT

| | |
|--------------------|--|
| Belt Width | 1000mm (40") Wide Belt |
| Mesh Access | Raises and lowers hydraulically to get access to screen meshes |
| Belt Speed | Variable Speed |

OVERSIZE CONVEYOR

| | |
|-------------------------|---|
| Belt Width | 1000mm (40") |
| Conveyor | 2in1 conveyor for mixing oversize and midsize product |
| Discharge Height | 3200mm (10'6") |
| Belt Speed | Variable Speed |

POWER

| | |
|--------------------------------|--|
| Engine | Deutz TD2.9 L4 (EU Stage IIIB, EPA Tier 4) 55kw (74HP) |
| Engine | Deutz TD2.9 L4 (EU Stage V) 55kw (74HP) |
| Fuel Tank Capacity | 200L |
| Hydraulic Tank Capacity | 450L |

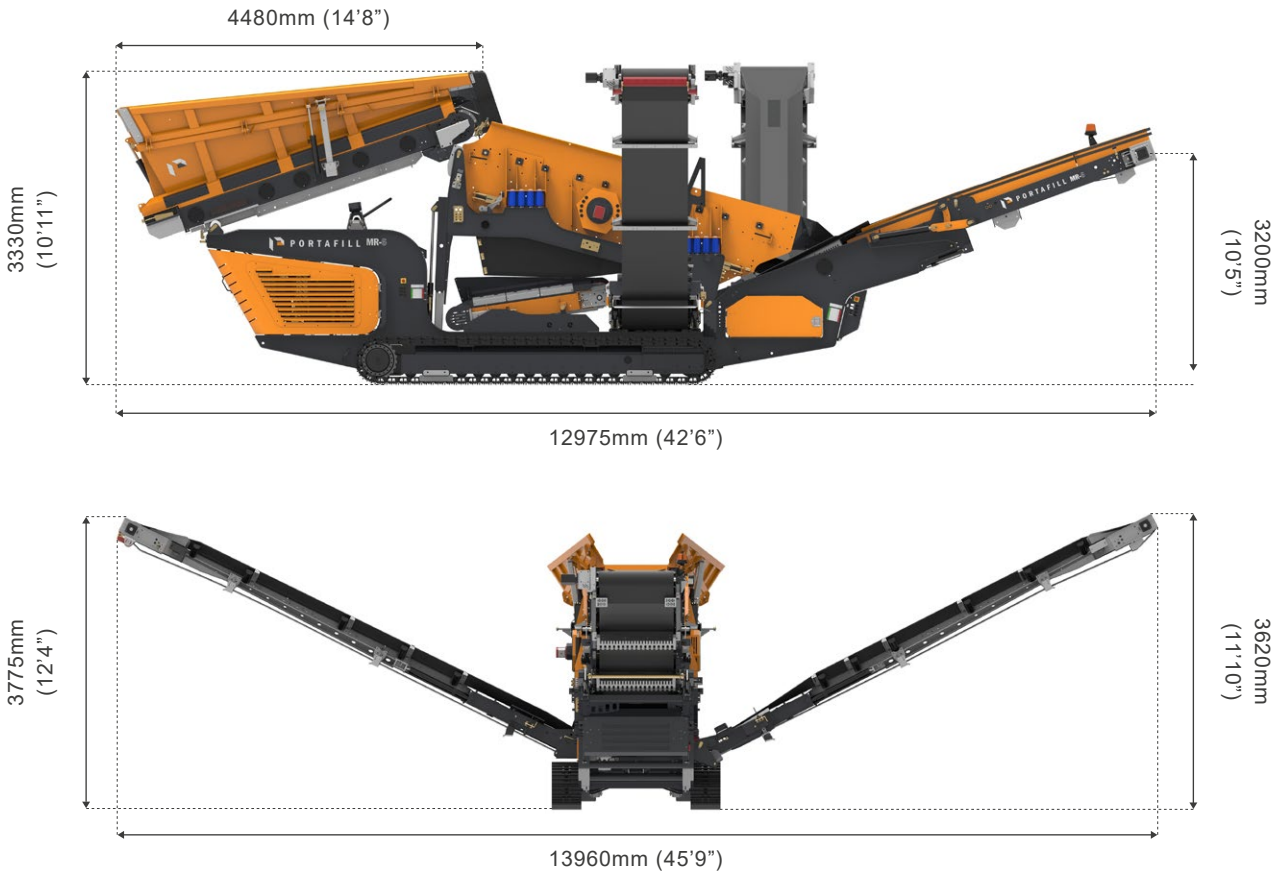
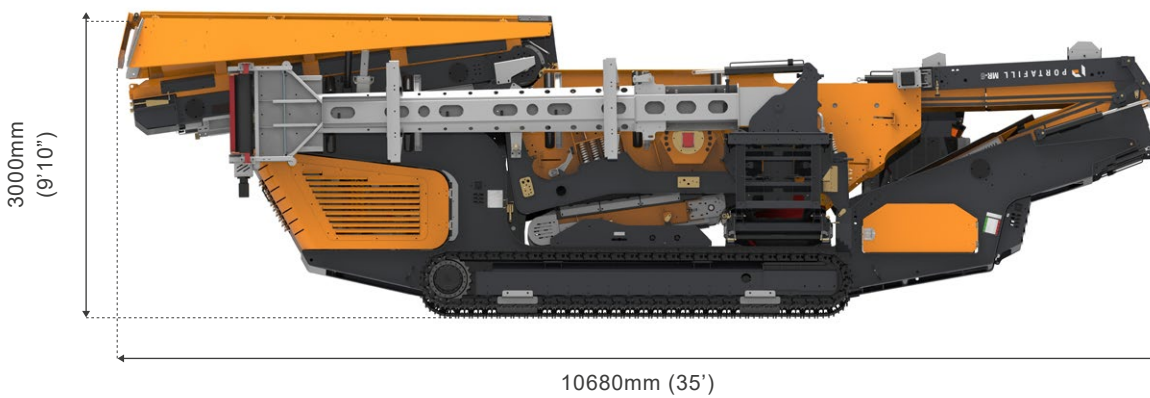
WORKING DIMENSIONS

TRANSPORT DIMENSIONS

| | |
|---|---|
| Transport Height 3000mm (9'10") | Transport Length 10680mm (35') |
| Transport Width 2550mm (8'4") | Weight 18,000kgs (Approx.) 41,000lbs (Approx.) |
| Patent Application NO. | |
| US 62 / 858,607 19178915.5 18162051.9 | |

* All drawings dimensions approximate and in millimetres and feet and inches. Portafill International reserves the right to alter the specification of the machines without notice. Images may show some optional equipment. E & OE.