



TECHNICAL SPECIFICATION

PORTAFILL MS-3



* All drawings dimensions approximate and in millimetres and feet and inches. Portafill International reserves the right to alter the specification of the machines without notice. Images may show some optional equipment. E & OE.

SCREEN BOX

Screen Box Type	Bolted, 2 Deck, 2 Bearing Screen
Overall Screen Box Size	2890mm (9'5") x 1200mm (4')
Screen Deck Options	Woven Wire Mesh Piano / Harp Wire

MAIN FEEDER CONVEYOR

Main Feeder Conveyor Width	800mm (32")
-----------------------------------	-------------

WING CONVEYORS

Belt Width	600mm (24")
Discharge Height	2700mm (8'10")
Wing Conveyors	Hydraulically folding for Transport
Head Drum	Retractable

FRONT CONVEYOR

Belt Width	800mm (32")
Discharge Height	2400mm (7'11")
Front Conveyor	Hydraulically folding for Transport

TIPPING GRID

Tipping Grid	Hydraulically Tipping Grid with Remote Control
Grid Bars	Replaceable Borox Grid Bars at 100mm Spacing
Hopper Volume	3.25 cubic metres
Maximum feed size	400mm on grid bars (depending on material)

POWER

Engine	Deutz D2011 L04I (EU Stage IIIA, EPA Tier 3) 36kw (49HP)
Engine	Deutz TCD2.2 L3 (EU Stage V, EPA Tier 4) 55kw (74HP)
Fuel Tank Capacity	100L
Hydraulic Tank Capacity	380L

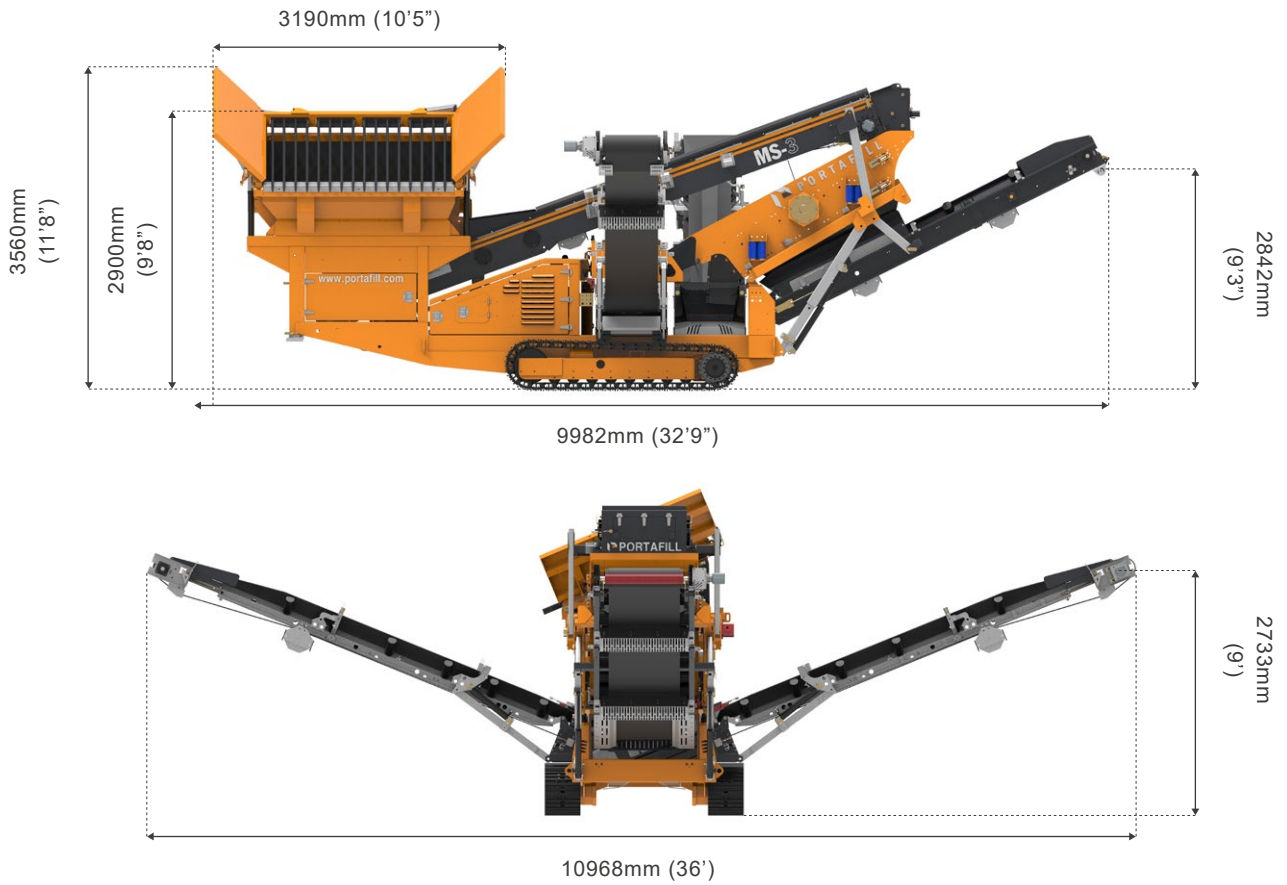
WORKING DIMENSIONS

TRANSPORT DIMENSIONS
