

TECHNICAL SPECIFICATION

PORTAFILL MS-6



* All drawings dimensions approximate and in millimetres and feet and inches. Portafill International reserves the right to alter the specification of the machines without notice. Images may show some optional equipment. E & OE.

SCREEN BOX

Screen Box Type	Bolted 2 Bearing Screen
Overall Screen Box Size - Two Deck	4900mm (16') x 1200mm (4')
Overall Screen Box Size - Optional 3 rd Deck	3750mm (12'3") x 1200mm (4')

MAIN BELT FEEDER

Feeder Width	1000mm (40")
--------------	--------------

WING CONVEYORS

Belt Width	750mm (30")
Discharge Height	3849mm (12'7")
Wing Conveyors	Hydraulically folding for transport

FRONT CONVEYOR - 2 DECK

Belt Width	1000mm (40")
Discharge Height	3995mm (13'1")
Front Conveyor	Telescopic folding for transport

AUXILIARY CONVEYOR - 3 DECK

Belt Width	500mm (20")
Discharge Height	3092mm (10'1")
Auxiliary Conveyor	Hydraulically folding for transport

FRONT CONVEYOR - 3 DECK

Belt Width	1000mm (40")
Discharge Height	3822mm (12'7")
Front Conveyor	Telescopic folding for transport

BIFOLDING GRID

Tipping Grid	Hydraulically Tipping Grid with Remote Control
Feed Width	3875mm (13')
Hopper Volume	4 cubic metre (5 cubic yard)
Tipping Grid Access	Tipping grid folds up for access for feed from other conveyor / crusher
Maximum Feed Size	400mm (depending on material)

POWER

Engine	Deutz TD2.9 L4 (EU Stage IIIB, EPA Tier 4) 55Kw (74HP)
Engine	Deutz TD2.9 L4 (EU Stage V) 55kw (74HP)
Fuel Tank Capacity	150L
Hydraulic Tank Capacity	500L

OTHER OPTIONS

1. Dual electric deisel power 50Kw
2. Three Deck model
3. Full Wash System for Two Deck or Three Deck models

WORKING DIMENSIONS MS-6 2 DECK

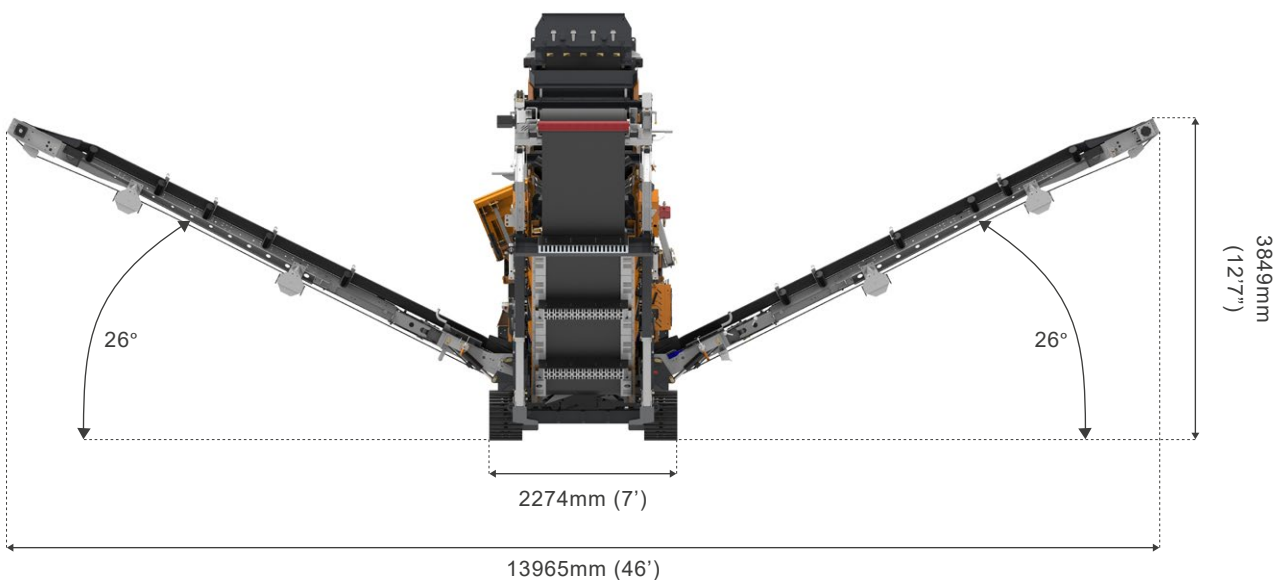
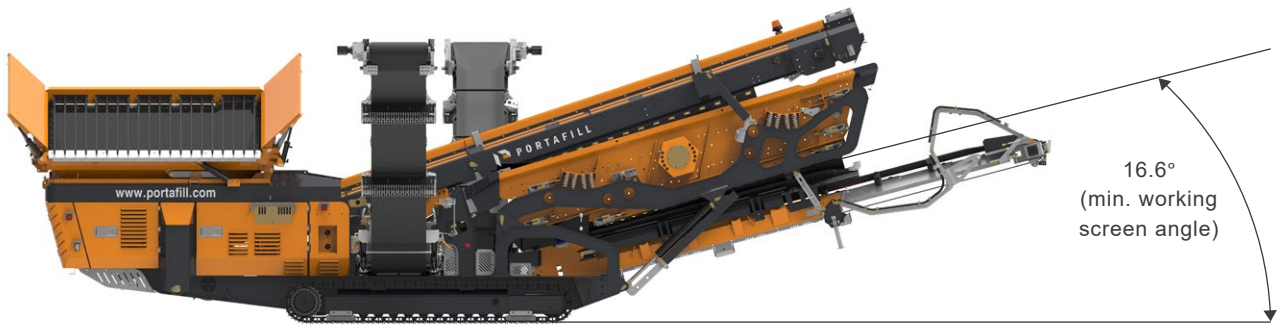

* All drawings dimensions approximate and in millimetres and feet and inches. Portafill International reserves the right to alter the specification of the machines without notice. Images may show some optional equipment. E & OE.

ISO VIEW - MS-6 2 DECK



TRANSPORT VIEW MS-6 2 DECK

Folds to fit inside 40ft Container

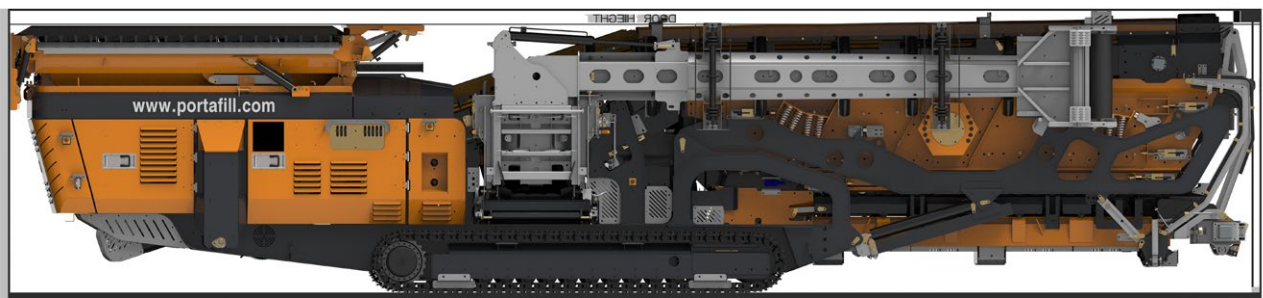

WORKING DIMENSIONS MS-6 3 DECK

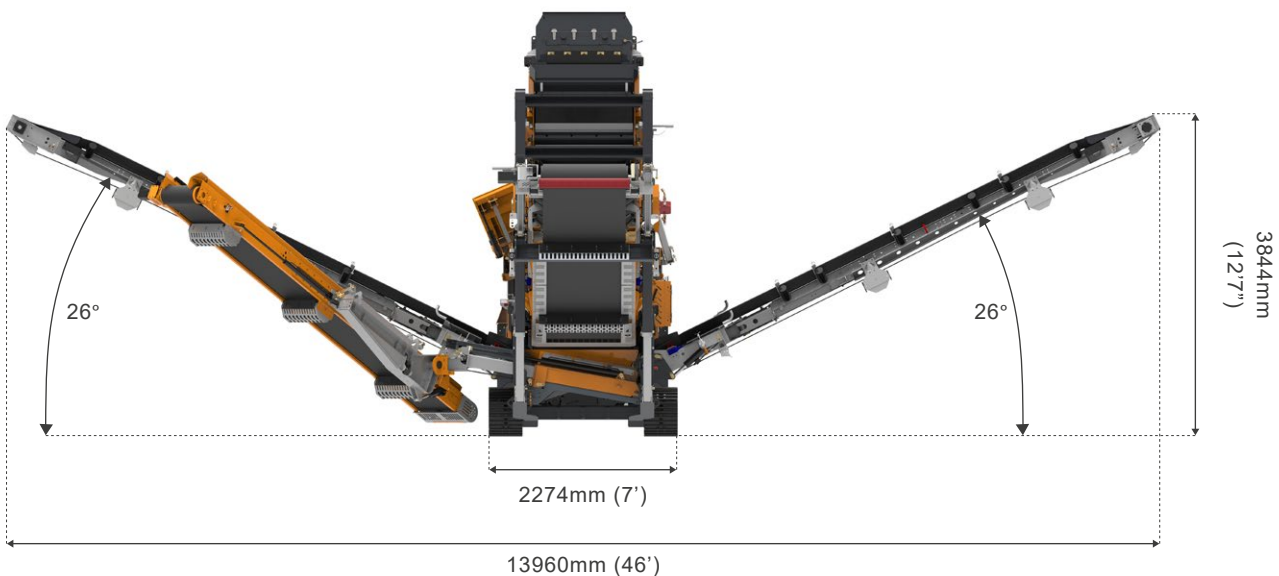
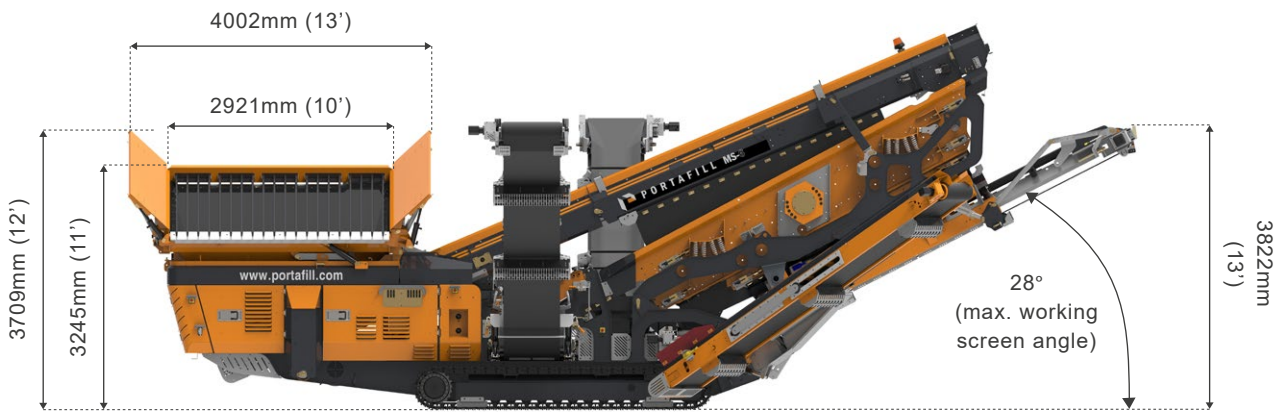
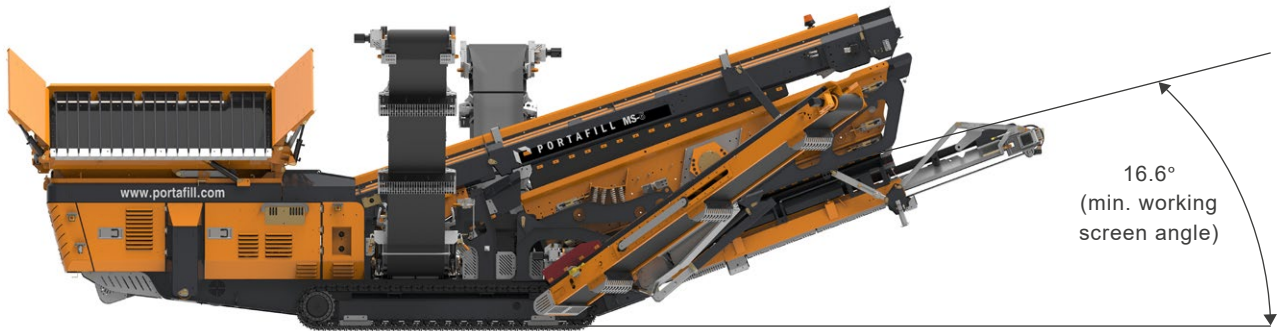

* All drawings dimensions approximate and in millimetres and feet and inches. Portafill International reserves the right to alter the specification of the machines without notice. Images may show some optional equipment. E & OE.

WORKING DIMENSIONS



ISO VIEW



* All drawings dimensions approximate and in millimetres and feet and inches. Portafill International reserves the right to alter the specification of the machines without notice. Images may show some optional equipment. E & OE.

TRANSPORT DIMENSIONS

Folds to fit inside 40ft Container

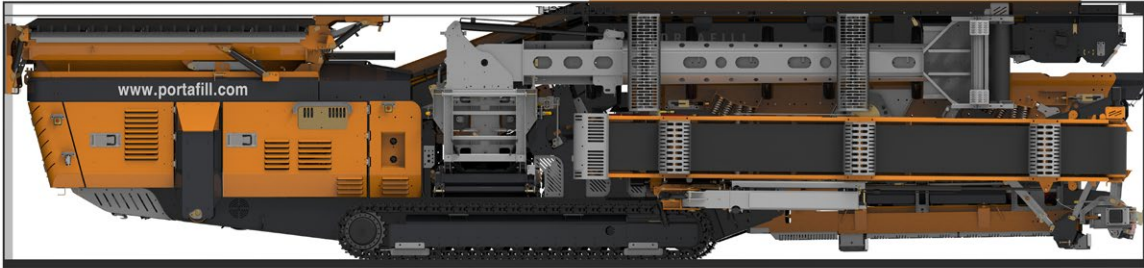

Transport Dimensions for Low Loader Transport - 2 or 3 Deck

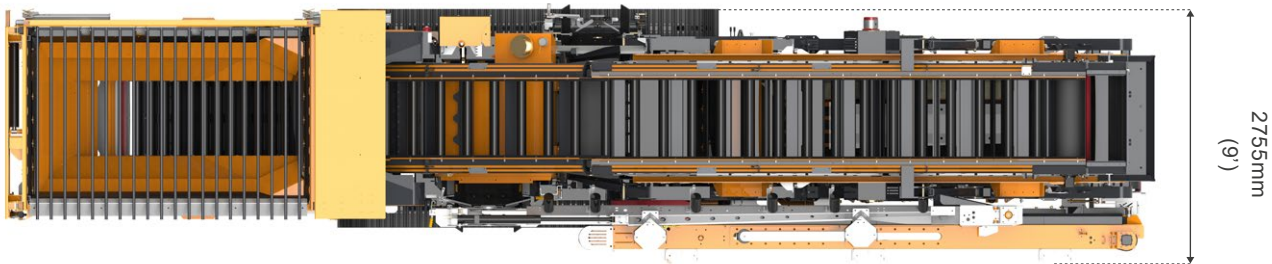
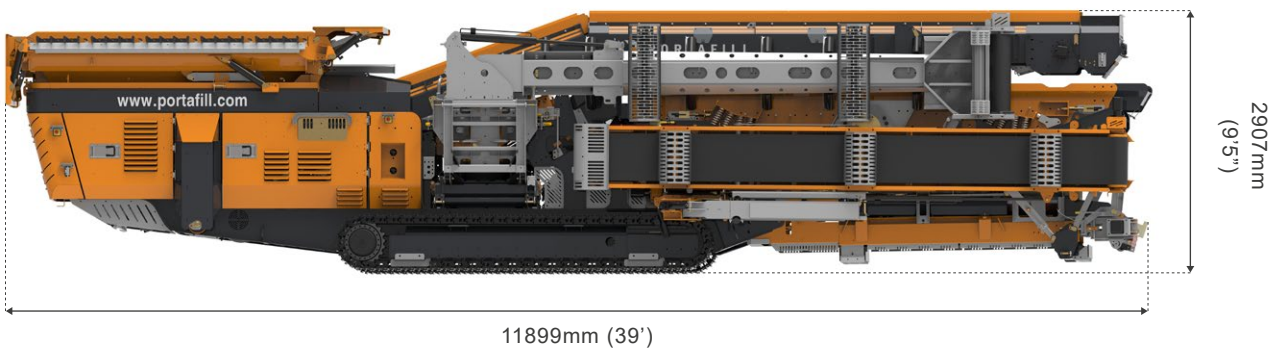

WEIGHTS

MS-6 2 DECK	MS-6 3 DECK
22,000kgs (Approx.)	23,400kgs (Approx.)
48,500lbs (Approx.)	51,600lbs (Approx.)