

# LMC

www.lmcarter.com

## 8603 WHEEL RAKE

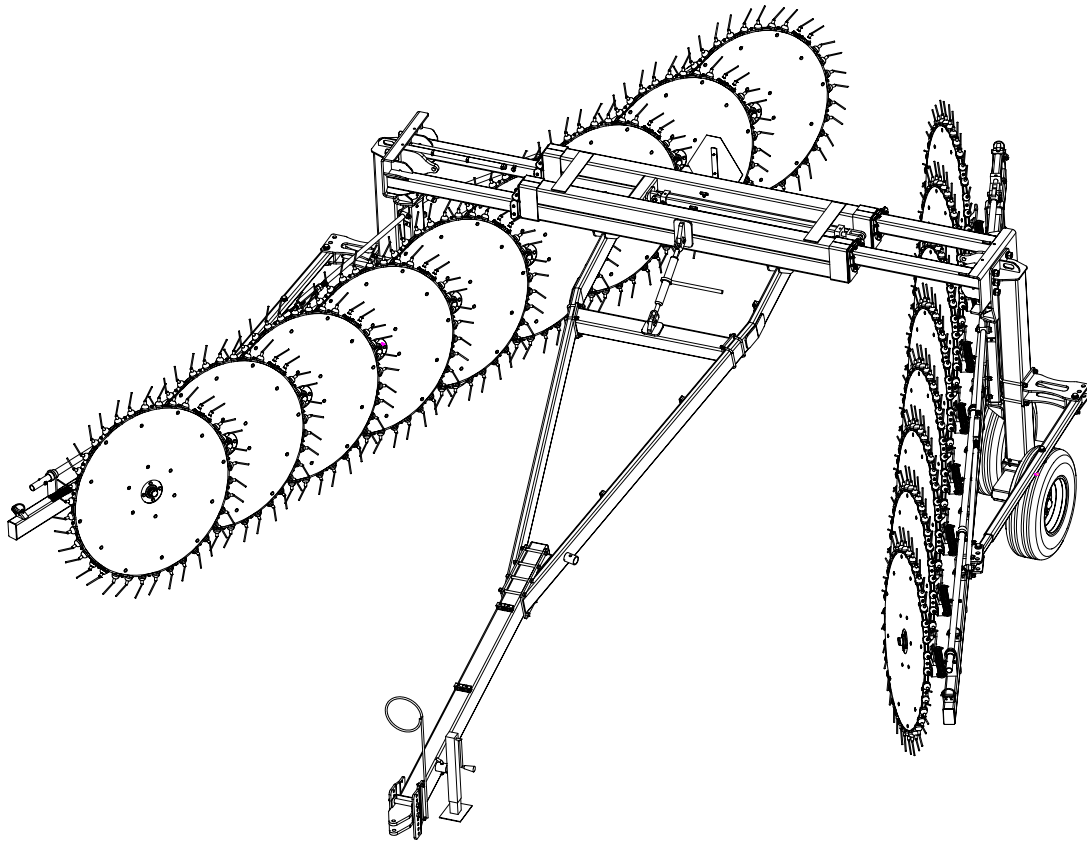

## OWNER-OPERATOR/PARTS MANUAL

NOVEMBER 2004

LMC  
P.O. Box 428  
HWY 84 West  
Donalsonville, GA 39845  
229-524-2197 1-800-332-8232  
FAX 229-524-2531

69-0002-86



MANUFACTURED BY:

**LMC**

CALL: 1-800-332-8232 OR 229-524-2197

MAILING ADDRESS: P.O. BOX 428, DONALSONVILLE, GA 31745

SHIPPING ADDRESS: HWY 84 WEST, DONALSONVILLE, GA 31745

## **MACHINE IMPROVEMENTS**

The Manufacturer reserves the right to make changes and improvements in the product at any time without notice. The Manufacturer shall not be obligated to incorporate such changes and improvements in products previously sold to any customer, nor shall the Manufacturer be obligated to replace previously sold products with customers incorporating such changes and improvements.

**(ALL RIGHTS RESERVED)**



# LMC 8603 RAKE OPERATORS MANUAL

<i>Safety Messages</i>	2—8
<i>Description of the Rake</i>	9
<i>Shipping, Unloading, Site Assembly, and Delivery</i>	10
<i>Pre-Delivery and Delivery List</i>	11—13
<i>Setup and Description of Controls</i>	14
<i>Jack Operation, Hitching and Unhitching</i>	15
<i>Frame Height</i>	16
<i>Transporting the rake</i>	17—18
<i>Maintenance</i>	19—23
<i>Parts Listing</i>	24—41
<i>Warranty Registration Card</i>	
<i>Warranty</i>	

## SAFETY SYMBOLS

### RECOGNIZE SAFETY INFORMATION

This is the safety symbol. When you see this, it means:

**ATTENTION!  
BECOME ALERT!  
YOUR SAFETY IS INVOLVED!**



Follow recommended precautions and procedures:

### UNDERSTAND SIGNAL WORDS

A signal word—**DANGER**, **WARNING**, or **CAUTION**— is used with the safety-alert symbol.

**DANGER** indicates imminently hazardous situations that, if not avoided, will result in serious injury, or death.

**WARNING** indicates potentially hazardous situations that, if not avoided, could result in serious injury, or death.

**WARNING** may also be used to alert against unsafe practices.

**CAUTION** indicates potentially hazardous situations that, if not avoided, could result in minor or moderate injury.

**CAUTION** may also be used to alert against unsafe practices.



**DANGER**



**WARNING**



**CAUTION**

### FOLLOW SAFETY INSTRUCTIONS

Carefully read all safety messages in this manual and on your machine safety signs. Keep safety signs in good condition. Remove missing or damaged safety signs. Contact LMC for replacement parts.

Learn how to operate the machine and how to use controls properly. Do not let anyone operate without instruction.

Keep your machine in proper working condition. Unauthorized modifications to the machine or disrepair may impair safety, or the machine function.



## SAFETY PRECAUTIONS



### ACCIDENTS CAN BE PREVENTED

Without the complete cooperation of the implement operator, no accident prevention program can be successful. The operator anticipating the results before an accident occurs and taking action to remedy the situation can prevent many accidents. No power driven equipment, whether it be for transportation or processing, whether it is used on the highway, in the field, or in the shop, can be safer than the person at the controls. If accidents are to be prevented, the operators who accept these responsibilities seriously will accomplish it. Elimination of careless acts and unsafe operation will be a help in getting your safety program off to a good start.

**READ THE OPERATORS MANUAL — BE ALERT**



**CAUTION: BEFORE APPROACHING OR ENTERING ANY MECHANISM TO SERVICE, INSPECT, OR MAKE ADJUSTMENTS.**

- A. LOWER UNIT TO THE GROUND
- B. SHUT THE TRACTOR OFF
- C. LOCK THE TRACTOR'S PARKING BRAKE
- D. REMOVE THE KEY

### PREPARE FOR EMERGENCIES

Be prepared in the event of personal injury, fire, or environmental problem.

Keep handy a first aid kit, tools, equipment, supplies, fire extinguisher, and proper attire for handling chemicals associated with the machinery usage.

Keep handy the emergency numbers for doctors, ambulance service, hospital, fire department, and any other emergency personnel.



**WARNING: AVOID HIGH-PRESSURE FLUIDS**

Escaping fluid under pressure can penetrate the skin causing serious injury.

Shut off tractor before connecting or disconnecting hydraulic lines at tractor.

Relieve pressure before unhooking hydraulic or other lines. Tighten all connections before applying pressure. Keep hand and body away from pinholes and components that may eject fluids under pressure. Use a piece of cardboard to search for leaks.

If ANY fluid is injected into the skin, it must be surgically removed within a few hours by a Doctor familiar with this type of injury.



## SAFETY PRECAUTIONS



1. Never connect hydraulic lines or operate any portion of the machine unless machine is hitched to tow vehicle or tractor.
2. Do not operate hydraulic systems when hydraulic leaks are present.
3. Never ride the machine during transport or movement.
4. Always observe local traffic laws when transporting unit on public roads.
5. Always operate machine in a careful, controlled manner.
6. Personnel operating and working with this machinery and in any related duties must be properly trained and free of conditions or substances that may impair safety or good judgment.
7. Personnel operating and working with this machinery must not wear loose, dangling or unbuttoned clothing which could tangle in machinery.
8. Always stay clear of parts that can move and entangle, pinch or crush.
9. System hydraulic pressure is to be set at minimum possible for proper operation. **DO NOT EXCEED 2000 psi WORKING PRESSURE OR 2500 psi MAXIMUM PRESSURE.**
10. Keep out of machine when in use.
11. Before starting machine, always check area around machine to verify that all personnel are clear.
12. Before transport or unhitching, always tie back hydraulic lines.
13. Before transport or unhitching, always tie back wires or cable with attached control panel, and place in the storage box.
14. Daily inspect fasteners for tightness (bolts, pins, etc.)
15. Always use proper procedures and equipment for handling, transporting, and storing any chemical associated with the usage of the machinery.
16. Before transport, always verify that no part of the machine can swing or slide out into the other traffic lanes, or drag on the roadway.
17. Before transport, inspect lug bolts and tire inflation.
18. Always park machine on flat ground for unhitching or storage. Before unhitching, place chocks in front and behind all transport wheels to prevent rolling when unhitched and parked.





## **SAFETY PRECAUTIONS**



19. Stand clear of tongue, framework and tow vehicle or tractor when operating jack or working with hitch. Look around to be sure that if something slipped or accidentally moved that no harm would occur.
20. Always lock brakes on tractor or towing vehicle, place in parking gear, and shut off tractor or towing vehicle before working with rake jack or unhitching rake.
21. Do not attempt to use torch or welding arc around the machine when in the crop, in the field, or around other flammable items.
22. Always wear proper safety attire for each usage condition or service procedure.
23. READ AND OBSERVE SAFETY SIGNS.
24. ALWAYS USE A PROPER HITCH PIN WITH A SAFETY CLIP INSTALLED TO HITCH THE RAKE TO THE DRAWBAR OF THE TRACTOR OR TOWING VEHICLE.
25. THE EQUIPMENT DOES NOT HAVE BRAKES. DO NOT TOW AT SPEEDS OVER 20 MPH.
26. OPERATOR IS TO TURN ON FLASHING WARNING LIGHTS WHENEVER TRAVELING ON A HIGHWAY, EXCEPT WHERE SUCH USE IS PROHIBITED BY LAW.
27. MAXIMUM FIELD SPEED NOT TO EXCEED 7 MPH.



## SAFETY SIGNS



# CUSTOMER RESPONSIBILITY

Safety signs must be kept legible. Replace any safety sign that becomes illegible (unreadable) or is missing.

Safety signs are supplied separately from equipment parts. It is the responsibility of the customer to purchase and affix safety signs per the equipment manufacturer's current recommendation, to any equipment part to be used during repair.

When ordering new equipment parts to be used during repair, always be sure to order any safety sign(s) to be affixed to that part. Safety signs can be ordered for LMC components from:

LMC  
P.O. Box 428  
Donalsonville, GA 31745  
Phone: 229-524-2197  
800-332-8232  
Fax: 229-524-2531

How to apply safety signs with self-adhesive backs:

1. Wash surface clean using a degreasing soap and water solution to remove all oil, solvent, and dust.
2. Use a square and pencil to mark decal location.
3. Using a wet cloth or spray bottle, apply a film of water to decal location.
4. Position decal and apply to equipment. Use a wet cloth or squeegee to remove air bubbles from each decal immediately after application.

## DECALS and SAFETY SIGNS



P/N 79-007-02  
Location: Facing outward on the framework  
above each wheel



P/N 79-039-36  
Location: Facing outward on the framework  
above each wheel



P/N 79-007-02  
Location: Facing outward on the framework above each wheel



P/N 79-185-88

Location: Outwardly facing, on each side of the main frame, behind the main frame members that "Vee" outwards from the tongue.



Location: Outwardly facing, on each side of the main frame, behind the main frame members that "Vee" outwards from the tongue.

# **DECALS and SAFETY SIGNS**

## DESCRIPTION OF THE LMC 8603 RAKE

The LMC 8603 Rake is a crop driven rake used in many heavy and custom applications.

The unitized frame is extended outward to each side for raking hay and retracted for transport to and from the field.

The left-hand delivery and right hand delivery wheels are a crop driven method of moving hay into a windrow, the wheel speed is in relation to tractor ground speed.

The following V-SETUP REFERENCE applies to the standard configuration of the LMC/ALLEN 8603 RAKE.

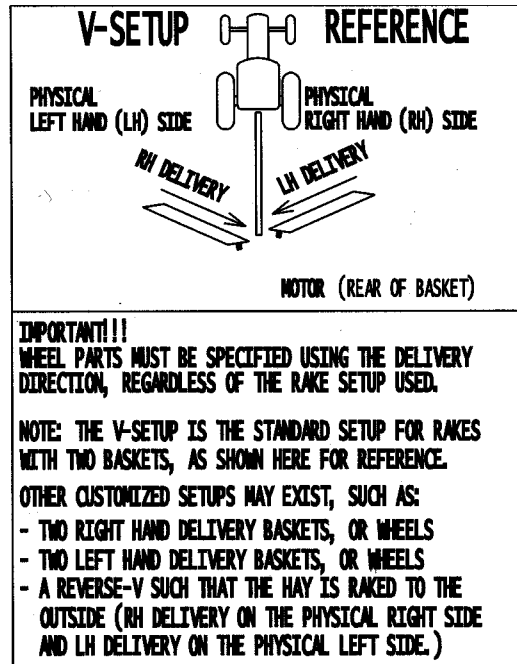

### Obtaining Assistance:

We at LMC appreciate your choice of this rake. If you need assistance, you can reach LMC at:

LMC  
P.O. Box 428  
Donalsonville, GA 31745  
Phone: (800) 332-8232 (229) 524-2197

## **SHIPPING, UNLOADING, SITE ASSEMBLY AND DELIVERY OF THE LMC 8603 RAKE**

The LMC 8603 Rake is shipped in a partially assembled condition. Before hoisting any component from the truck or container, be sure that it is secured in a manner that will not allow accidental movement or falling.



### **CAUTION**

**BEFORE ATTEMPTING TO UNLOAD, ASSEMBLE, OR DELIVER THE COTTON CART, READ THE SAFETY SECTION OF THIS MANUAL. BE ESPECIALLY AWARE OF THE FOLLOWING PRECAUTIONS:**

- ➔ Always wear proper safety attire for each usage condition or service procedure.
- ➔ During unloading and assembly, always stand clear. Look around to be sure that if something slipped or accidentally moved that no harm would occur.
- ➔ Stand clear of tongue, framework and tow vehicle or tractor when operating jack or working with hitch. Look around to be sure that if something slipped or accidentally moved that no harm would occur.
- ➔ Before transport, inspect lugs bolts and tire inflation
- ➔ Before transport, always verify that no part of the machine can swing or slide out into other traffic lanes or drag on the roadway.

Pictures and instructions can be found throughout this manual to assist in the required site assembly.

Refer to the transport instructions in the manual prior to delivery of the Cotton Cart to the customer or work site.

See the Delivery Checklist prior to delivery or operation of the rake. (Next Page)

**PRE-DELIVERY AND DELIVERY LIST  
FOR THE DEALER, CUSTOMER, AND OPERATOR  
LMC 8603 RAKE**

NOTE: Dealer, Customer, and Operator should review each item on this list together in order to know how each was accomplished.

1.



**CAUTION**

Review the Operator's Manual. Note especially the instruction for:

- ➔ Safety
- ➔ Unloading
- ➔ Assembly
- ➔ Operation
- ➔ Transportation
- ➔ Service and Maintenance
- ➔ Emergency Procedures

2. Check all fasteners for tightness. Refer to the suggested tightening torque values for SAE Grade 5 bolts, below:

Size	Minimum Torque		Size	Minimum Torque	
	<u>Gr. 5 (Foot-Lbs)</u>	<u>Gr. 8 (Foot-Lbs)</u>		<u>Gr. 5 (Foot-Lbs)</u>	<u>Gr. 8 (Foot-Lbs)</u>
1/4	7	10	5/8	125	173
5/16	15	21	3/4	225	306
3/8	25	35	7/8	340	495
7/16	41	57	1	510	740
1/2	63	87			

3. **THIS EQUIPMENT DOES NOT HAVE BRAKES. DO NOT TOW AT SPEEDS OVER 20 MPH. OPERATOR IS TO TURN ON FLASHING WARNING LIGHTS WHENEVER TRAVELING ON A HIGHWAY, EXCEPT WHERE SUCH USE IS PROHIBITED BY LAW.**

**PRE-DELIVERY AND DELIVERY LIST  
FOR THE DEALER, CUSTOMER, AND OPERATOR  
LMC 8603 RAKE**

4. Inspect rake systems:



**CAUTION: BEFORE APPROACHING OR ENTERING ANY MECHANISM TO SERVICE, INSPECT, OR MAKE ADJUSTMENTS.**

- A. LOWER UNIT TO THE GROUND
  - B. SHUT THE TRACTOR OFF
  - C. LOCK THE TRACTOR'S PARKING BRAKE
  - D. REMOVE THE KEY
- 
- A. With the hydraulic hoses **NOT** connected to the tractor, turn the raking wheels by hand. All parts should move freely. Wheel hub bearings have been tightened to proper torque.
  - B. With the hydraulic hoses NOT connected to the tractor, review the hydraulic system for proper tightness of all fittings.
  - C. With the tractor engine shut off, connect the hydraulic hoses to the tractor.
  - D. Slowly and carefully turn on the tractor hydraulics to begin operation.
  - E. With the tractor safely parked and while keeping clear of the rake, visually inspect for loose parts and hydraulic leaks. Should there be any problems, follow all safety procedures, especially the messages given with this step and remedy the problem.
  - F. For field representation, the main frame needs to be parallel to the ground when hitched to the towing machine
  - G. Adjust the wheel beams to be parallel to the main frame. This allows more equal adjustment on the raking wheels.
  - H. Adjust raking wheels to have as light a contact with the conditioned crop as ground condition and ground speed will allow.



**WARNING: AVOID HIGH-PRESSURE FLUIDS**

- 1. Escaping fluid under pressure can penetrate the skin causing serious injury.
- 2. Shut off tractor before connecting or disconnecting hydraulic lines at tractor.
- 3. Relieve pressure before unhooking hydraulic or other lines. Tighten all connections before applying pressure. Keep hand and body away from pinholes and components that may eject fluids under pressure. Use a piece of cardboard to search for leaks.
- 4. If ANY fluid is injected into the skin, a doctor familiar with this type of injury must surgically remove it within a few hours.



(PHOTOCOPY THIS PAGE)

**PRE-DELIVERY AND DELIVERY LIST  
FOR THE DEALER, CUSTOMER, AND OPERATOR  
LMC COTTON CART**

NOTE: Dealer, Customer, and Operator should review each item on this list together in order to know how each was accomplished.

6. Warranty Registration:

Customer must complete and send in the warranty registration card that is attached to the back of the manual. Warranty validation will not occur unless warranty registration card is returned to:

LMC  
P.O. Box 428  
Donalsonville, GA 31745  
Attn: Warranty Department  
Phone: (229) 524-2197 (800) 332-8232

7. Record the serial number here for future reference.

Serial Number: \_\_\_\_\_

---

(PHOTOCOPY THIS PAGE)

LMC welcomes any comments regarding the condition of the rake upon arrival at the dealership or farm.

Comments:

\_\_\_\_\_  
\_\_\_\_\_  
\_\_\_\_\_  
\_\_\_\_\_  
\_\_\_\_\_  
\_\_\_\_\_

Signature:

Mail to: LMC , P.O. Box 428, Donalsonville, GA 31745

## SETUP AND DESCRIPTION OF CONTROLS LMC 8603 RAKE



### CAUTION

Read all SAFETY MESSAGES at the beginning of this manual before attempting any of the procedures described in this section.



### NOTE

In order to set up your LMC/ALLEN rake, it may be necessary to utilize certain hydraulic functions.

If so, the rake will need a preliminary hydraulic setting. To achieve this preliminary setting, refer to the section of this manual, "*PREDELIVERY AND DELIVERY LIST*". Perform all the steps.

The hydraulic settings in the "*PREDELIVERY AND DELIVERY LIST*" will be sufficient to operate the rake functions during the set-up of the rake. Follow all of the safety precautions.

#### BEFORE RAKING HAY:

Instruct operator proper operation and safety of the 8603 Wheel Rake.

#### CONNECTIONS TO TRACTOR

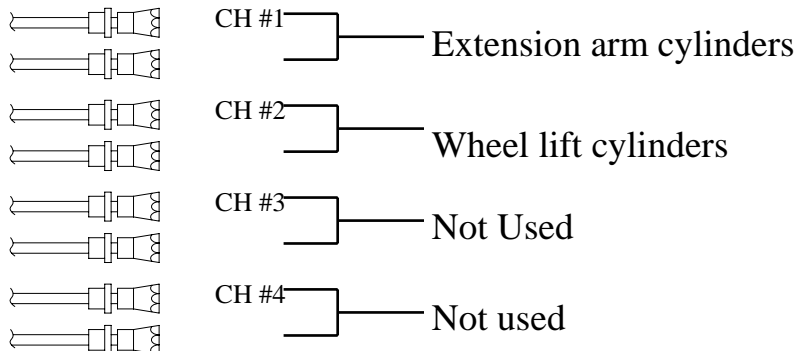

Refer to the illustration in the following section to assembly the rake.

## JACK OPERATION LMC 8603 RAKE

Read the following safety precautions, then sequentially follow the instructions given below. A pictorial reference is provided.



### CAUTION

**Stand clear of tongue, framework and tow vehicle or tractor when operating jack or working with hitch. Look around to be sure that if something slipped or accidentally moved that no harm would occur.**

**Always park machine on flat ground for unhitching or storage. Before unhitching, place chocks in front and behind all transport wheels to prevent rolling when unhitched and parked.**

**Always lock brakes on tractor or tow vehicle, place in parking gear and shut off tractor or vehicle before working with the rake jack or unhitching rake.**

**ALWAYS USE A PROPER HITCH PIN WITH A SAFETY CLIP INSTALLED TO HITCH THE RAKE TO THE DRAWBAR OF THE TRACTOR OR TOWING VEHICLE. (See figure, next page.)**

### HITCHING

Using the jack's crank handle, raise or lower the rake tongue to align the rake hitch with the drawbar of the tractor or tow vehicle. Securely hitch rake to tractor using a proper hitch pin with a safety clip installed. Use the jack's crank handle to take the pressure off of the jack foot. Pull the jack foot pin and push the jack foot fully up inside the leg of the jack. Insert jack foot pin into the aligned holes in the leg of the jack and the raised foot. Use the jack's crank handle to fully retract the leg of the jack to the transport position.

### UNHITCHING

Before unhitching the rake from the tractor or tow vehicle, pull the jack foot pin and lower the jack foot as far as possible to have aligned holes in the side of leg and foot of the jack. Insert the jack foot pin into the aligned holes. Using the rake's crank handle, raise the rake hitch off of the drawbar of the tractor or tow vehicle. After chocking front and back of the rake wheels, unhitch the rake.

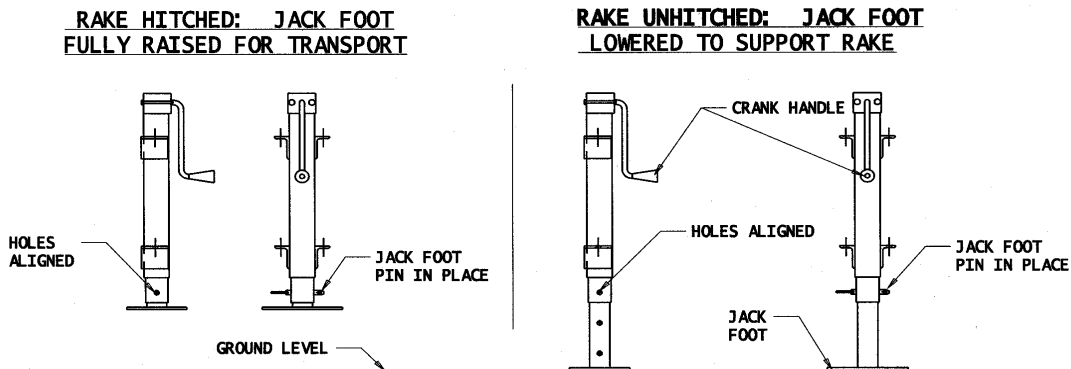

## FRAME HEIGHT LMC 8603 RAKE



### CAUTION

Stand clear of tongue, framework and tow vehicle or tractor when operating jack or working with hitch. Look around to be sure that if something slipped or accidentally moved that no harm would occur.

Always lock brakes on tractor or tow vehicle, place in parking gear and shut off tractor or vehicle before working with the rake jack or unhitching rake.

ALWAYS USE A PROPER HITCH PIN WITH A SAFETY CLIP INSTALLED TO HITCH THE RAKE TO THE DRAWBAR OF THE TRACTOR OR TOWING VEHICLE.

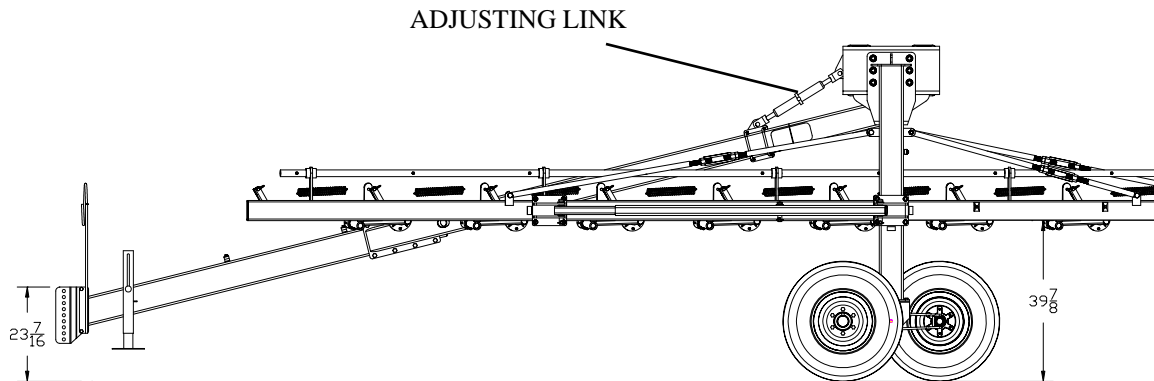

### FRAME HEIGHT:

For proper and consistent raking, the top surface of the tongue should be initially set approx. 23-7/16" off the ground. Then use the adjusting link to level the raking arms.

To change the frame height:

First, support the rake with the jack. See "*Jack Operation*" in this manual.

Secondly, reposition the hitch height using the bolt holes provided on the rake tongue. Torque hitch bolts properly. See chart in "*...Delivery List*".

The 23-7/16" frame height is the nominal setting to start from as a reference. This height will vary depending on tire pressure, wear of the tines, etc. Setting a level frame height can reduce the amount of wheel readjustment required when changing from one raking position to another. (See "*Raking Positions*" in this manual.)

The frame height should be taken note of when:

- adjusting the overall rake to the individual raking preference.
- adjusting the rake baskets to the individual raking preference.
- changing to another raking tractor.

## **TRANSPORTATION LMC 8603 RAKE**



**CAUTION**

Read all safety instructions at the beginning of the manual. Especially regard the following:

**ALWAYS USE A PROPER HITCH PIN WITH A SAFETY CLIP INSTALLED TO HITCH THE RAKE TO THE DRAWBAR OF THE TRACTOR OR TOWING VEHICLE.**

**THIS EQUIPMENT DOES NOT HAVE BRAKES. DO NOT TOW AT SPEEDS OVER 20 MPH.**

**OPERATOR IS TO TURN ON FLASHING WARNING LIGHTS WHENEVER TRAVELING ON A HIGHWAY, EXCEPT WHERE SUCH USE IS PROHIBITED BY LAW.**

Never connect hydraulic lines or operate any portion of the machine unless machine is hitched to tow vehicle or tractor.

Never ride on the machine during transport or movement.

Always observe local traffic laws when transporting unit on public roads.

Personnel operating and working with this machinery and in any related duties must be properly trained and free of conditions or substances that may impair safety or good judgment.

Before transport or unhitching, always tie back hydraulic hoses.

Before transport or unhitching, always tie back wires or cable with attached control panel and place in the storage box.

Before transport, always verify that no part of the machine can swing or slide out into other traffic lanes or drag on the roadway.

Before transport, inspect lug bolts and tire inflation.

Always park machine on flat ground for unhitching or storage. Before unhitching, place chocks in front and behind all transport wheels to prevent rolling when unhitched and parked.

Stand clear of tongue, framework and tow vehicle or tractor when operating jack or working with hitch. Look around to be sure that of something slipped or accidentally moved that no harm would occur.

Always lock brakes on tractor or tow vehicle, place in parking gear and shut off tractor or vehicle before working with the rake jack or unhitching rake.

### **TRANSPORTING INSTRUCTIONS:**

While following safety procedures, put the rake into the compact transport position, as shown on the next page. Drive slowly (20 mph or less). Drive carefully, always being aware of the rake's position in relation to traffic and roadside objects.

**TRANSPORTATION  
LMC 8603 RAKE**

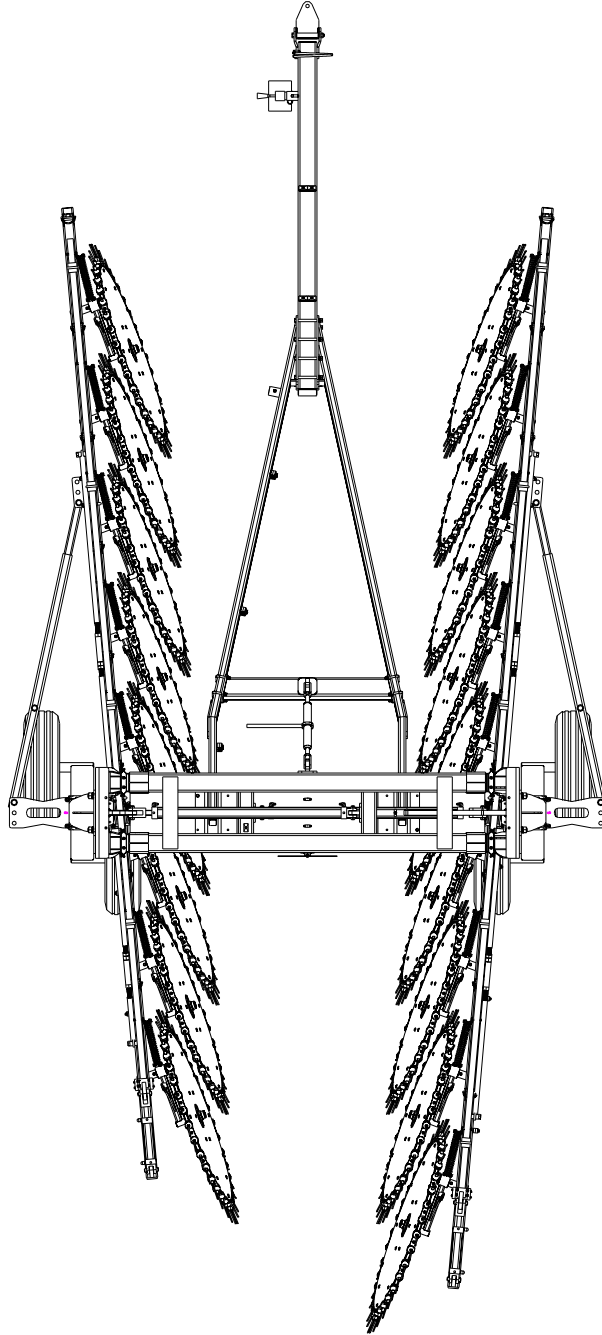

**TOP VIEW**

MAINTENANCE  
8603 WHEEL RAKE

## MAINTENANCE LMC 8603 WHEEL RAKE



### CAUTION

Read all SAFETY MESSAGES at the beginning of this manual before attempting any of the procedures described in this section.

Regard especially the following:

BEFORE APPROACHING OR ENTERING ANY MECHANISM TO SERVICE, INSPECT, OR MAKE ADJUSTMENTS:

- A. LOWER UNIT TO THE GROUND.
- B. SHUT THE TRACTOR OFF.
- C. LOCK THE TRACTOR'S PARKING BRAKE.
- D. REMOVE THE KEY.

### STAND CLEAR

Look around to be sure that if something slipped or accidentally moved that no harm would occur.

Personnel operating and working with machinery must not wear loose, dangling or unbuttoned clothing that could tangle in machinery.



### WARNING: AVOID HIGH-PRESSURE FLUIDS

1. Escaping fluid under pressure can penetrate the skin causing serious injury.
2. Shut off tractor before connecting or disconnecting hydraulic lines at tractor.
3. Relieve pressure before unhooking hydraulic or other lines. Tighten all connections before applying pressure. Keep hand and body away from pinholes and components that may eject fluids under pressure. Use a piece of cardboard to search for leaks.
4. If ANY fluid is injected into the skin, a doctor familiar with this type of injury must surgically remove it within a few hours.



## LMC WHEEL RAKE



### **WARNING** **CAUTION**

Read all safety messages on previous page before attempting any of these procedures.



### **WARNING** **CAUTION**

When replacing poly slide bearings and shims, always do repair to one side at a time.

- 1) Elevate main frame off of the ground or surface with a hydraulic jack from underneath or use some type of lifting system such as a chain hoist or crane from overhead.
- 2) After raising frame, extend extension arm out until it is fully extended and detach the upper hose rack from the extension arm.
- 3) At this time detach the extension cylinder from the extension arm.
- 4) Once the extension arm is fully extended, secure the extension arm to prevent the arm from falling. Use an overhead crane or a forklift from underneath to support extension arm.
- 5) Determine which bearing needs to be replaced. Once they have been determined, remove the (2) 3/8"–16 x 1" hex bolts from the poly.
- 6) After removing bolts, slide the poly out of the main frame.
- 7) After removing the worn poly, position new poly slide back in place and anchor back in place.
- 8) Push extension arm back into mainframe to line up hole to reconnect the extension arm cylinder.
- 9) Remove apparatus holding extension arm, and then retract extension while watching the upper hose rack closely to prevent any binding or interference with hydraulic hoses.
- 10) When the arm is fully retracted, bolt the hose rack back in place.
- 11) Now repeat the same steps to do opposite side of the rake.
- 12) After completion, lower main frame back down where it supported by the extension arms only.

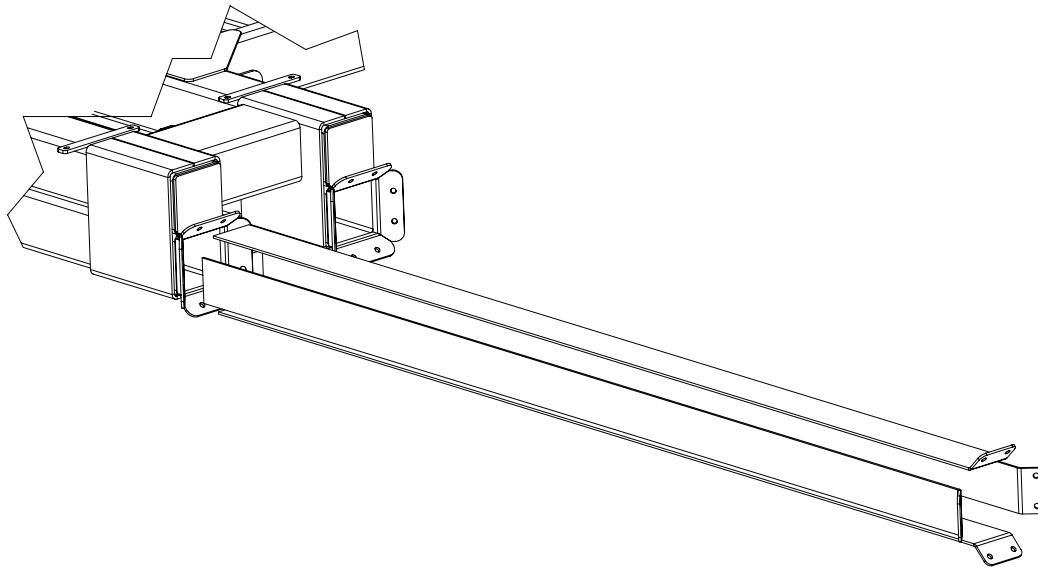

## MAINTENANCE LMC WHEEL RAKE



### CAUTION

Read all SAFETY MESSAGES at the beginning of this manual before attempting any of the procedures described in this section.

Regard especially the following:

BEFORE APPROACHING OR ENTERING ANY MECHANISM TO SERVICE, INSPECT, OR MAKE ADJUSTMENTS:

- A. LOWER UNIT TO THE GROUND.
- B. SHUT THE TRACTOR OFF.
- C. LOCK THE TRACTOR'S PARKING BRAKE.
- D. REMOVE THE KEY.

### STAND CLEAR

Look around to be sure that if something slipped or accidentally moved that no harm would occur.

Personnel operating and working with machinery must not wear loose, dangling or unbuttoned clothing that could tangle in machinery.



### WARNING: AVOID HIGH-PRESSURE FLUIDS

1. Escaping fluid under pressure can penetrate the skin causing serious injury.
2. Shut off tractor before connecting or disconnecting hydraulic lines at tractor.
3. Relieve pressure before unhooking hydraulic or other lines. Tighten all connections before applying pressure. Keep hand and body away from pinholes and components that may eject fluids under pressure. Use a piece of cardboard to search for leaks.
4. If ANY fluid is injected into the skin, a doctor familiar with this type of injury must surgically remove it within a few hours.

## LMC WHEEL RAKE



**WARNING** Read all safety messages on previous page before attempting any of these procedures.  
**CAUTION**

### Spindle Replacement Instructions

- 1) Remove hub, Item 1, and bearings, Item 2. See Fig. 28
- 2) Remove spindle bolt, Item 3.
- 3) Remove spindle.
- 4) Replace spindle bolt, bearing, and hub.

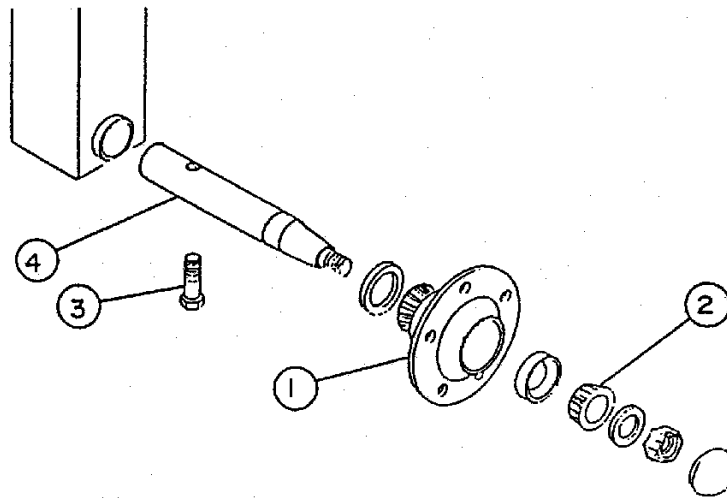
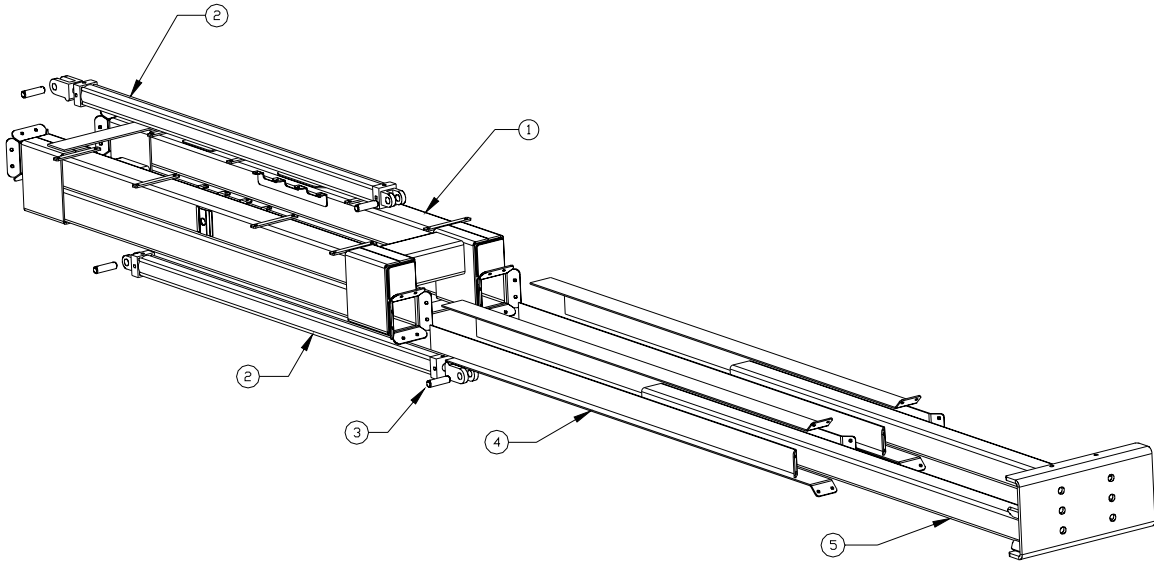

Fig. 28

**PARTS LIST**  
**8603 WHEEL RAKE**

## MAIN FRAME LMC 8603 RAKE



ITEM NO.	DESCRIPTION	PART NO.	QUANTITY
1	WELDMENT, 8603 MAIN FRAME	85-0014-86	1
2	CYLINDER, 2-1/2" DIA. X 48" STROKE	79-1023-86	2
3	PIN, CLEVIS WITH 2 COTTER PINS	77-003-85	4
4	POLY, SLIDE BEARINGS	68-0001-86	16
5	WELDMENT, 8603 EXTENSION ARM	85-0016-86	2
NS	FITTING, #6 BULKHEAD	79-013-88	4
NS	NUT, #6 BULKHEAD LOCK	79-1002-88	4
NS	ELBOW, #6MJ—#6NPT 90 DEG	79-1023-86	4
NS	TEE, #6MJ—#6MJ—#6MJ	79-014-20	4
NS	HOSE, 1/4" X 9" LONG CYLINDER EXTEND	79-1002-86	2
NS	HOSE, 1/4" X 40" LONG CYLINDER RETRACT	79-1003-86	2
NS	HOSE, 1/4" X 112" LONG WHEEL LIFT	79-1004-86	4
NS	CLAMP, #2127/127D TWIN HOSE	77-024-36	4
NS	PLATE, CLAMP TOP	77-032-38	2
NS	BOLT, 5/16" X 1-3/8" HEX	2816-1013	2
NS	SPRING, HOSE RETRACT	79-1019-86	2
POLY SLIDE BEARING FASTENERS			
NOT SHOWN	NUT, 3/8" UNC STOVER HEX	1412-1200	32
NOT SHOWN	WASHER, 3/8" SAE FLAT	4402-1200	32
NOT SHOWN	BOLT, 3/8" X 1" GRADE 5 HEX	2816-1210	32

**TONGUE (#84-0016-86)**  
**LMC 8603 RAKE**

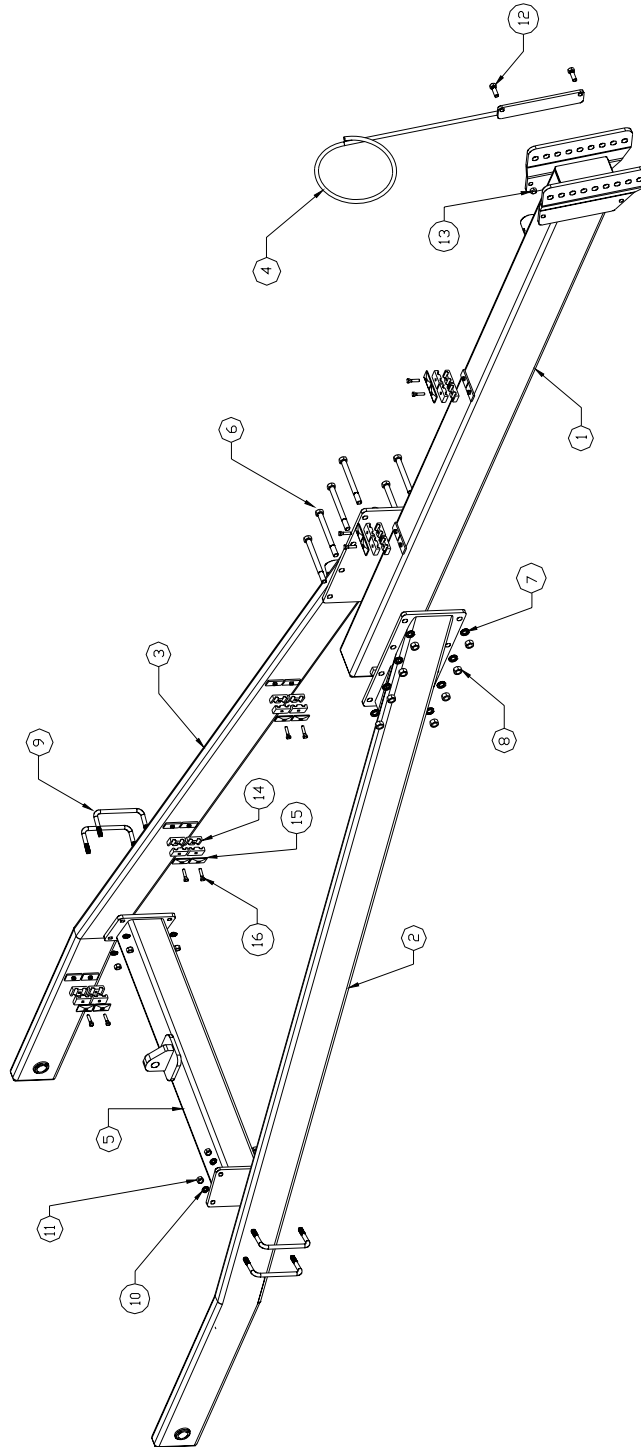

**TONGUE (#84-0016-86)**  
**LMC 8603 RAKE**

ITEM NO.	DESCRIPTION	PART NO.	QUANTITY
1	WELDMENT, 8603 TONGUE MAIN	85-0017-86	1
2	WELDMENT, 8603 TONGUE RH SIDE	85-0019-86	1
3	WELDMENT, 8603 TONGUE LH SIDE	85-0018-86	1
4	WELDMENT, 8603 TONGUE HOSE HOLDER	85-0026-86	1
5	WELDMENT, 8603 TONGUE CENTER TUBE	85-0020-86	1
6	BOLT, 5/8" X 7" LONG GRADE 5 HEX	2816-2070	8
7	WASHER, 5/8" REGULAR LOCK	1602-2000	8
8	NUT, 5/8" HEX	0812-2000	8
9	U-BOLT, 1/2 X 6-1/8 X 3-1/4 PLATED	79-1010-86	4
10	WASHER, 1/2" REGULAR LOCK	1602-1600	8
11	NUT, 1/2" HEX	0812-1600	8
12	BOLT, 1/2" X 1-1/2" GRADE 5 HEX	2816-1614	2
13	NUT, 1/2" STOVER HEX	1412-1600	2
14	CLAMP, #2127/127D TWIN HOSE (HALF)	77-024-36	20
15	PLATE, TWIN CLAMP TOP	77-032-38	10
16	BOLT, 5/16" X 1-3/8" LONG GRADE 5 HEX	2816-1013	10
NOT SHOWN	ADAPTOR, QUICK DISCONNECT	79-212-36	4
NOT SHOWN	HOSE, 1/4" X 310" LONG TONGUE	79-1011-86	4

# WHEEL POSTS LMC 8603 RAKE

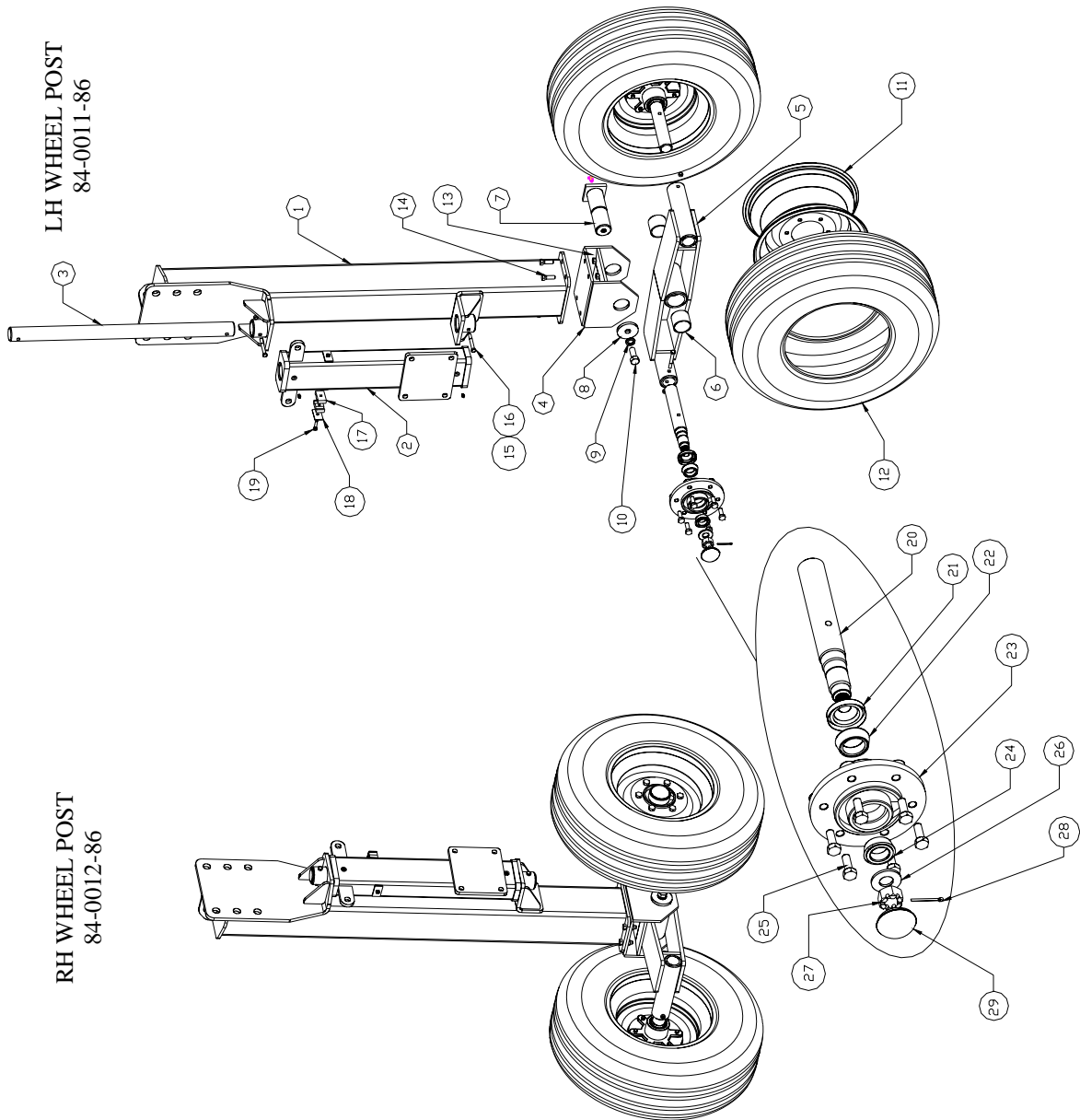



## WHEEL POSTS LMC 8603 RAKE

ITEM NO.	DESCRIPTION	PART NO.	QUANTITY
1	WELDMENT, 8603 RAKE WHEEL POST	85-0010-86	2
2	ASSEMBLY, PIVOT TUBE	84-0010-86	2
	WELDMENT, PIVOT TUBE	85-0011-86	1
	FITTING, 5/16" DRIVE IN GREASE	79-6441-40	2
3	SHAFT, WHEEL ARM PIVOT	96-0003-86	2
4	WELDMENT, 8603 RAKE WALKER POST	85-0007-86	2
5	WELDMENT, 8603 WALKING BEAM	85-0008-86	2
6	BUSHING, HARDENED 2-1/2" O.D.	79-069-23	4
7	ASSEMBLY, 8603 WALKER PIVOT PIN	84-0007-86	2
	WELDMENT, 8603 WALKER PIN	85-0009-86	1
	FITTING, 1/8" NPT 90 DEG GREASE	79-029-28	1
8	PLATE, PIVOT PIN END CAP	93-022-23	2
9	WASHER, 3/4" REGULAR LOCK	1602-2400	2
10	BOLT, 3/4" X 2" LONG GRADE 5 HEX	2816-2420	2
11	WHEEL, 15 X 8LB 6-6-4.62, #3800	79-010-02	4
12	TIRE, 9.5L15 8 PLY	79-003-01	4
13	NUT, 1/2" STOVER HEX	1412-1600	8
14	BOLT, 1/2" X 1-1/2" GRADE 5 HEX	2816-1614	8
15	BOLT, 3/8" X 3" LONG GRADE 5 HEX	2816-1230	8
16	NUT, 3/8" STOVER HEX	1412-1200	8
17	CLAMP, #2127/127D TWIN HOSE	77-024-36	4
18	PLATE, CLAMP TOP	77-032-38	2
19	BOLT, 5/16" X 1-3/8" GRADE 5 HEX	2816-1013	2
20	ROUND, SPINGLE, Q888 HUB	96-034-88	4
21	SEAL, Q888 HUB GREASE	77-006-02	4
22	BEARING, Q888 HUB INNER	77-007-02	4
23	HUB Q888 6 BOLT (WITH CUPS)	77-001-02	4
24	BEARING, Q888 HUB OUTER	77-008-02	4
25	BOLT, 1/2-20 X 1-1/4" LONG LUG	77-013-02	24
26	WASHER, Q888 HUB SPINDLE	77-005-02	4
27	NUT, 7/8" CASTLE	77-004-02	4
28	PIN, 5/32" X 1-3/4" LONG COTTER	77-011-02	4
29	CAP, Q888 HUB DUST	77-012-02	4

**MAIN FRAME W/ TONGUE**  
**LMC 8603 RAKE**

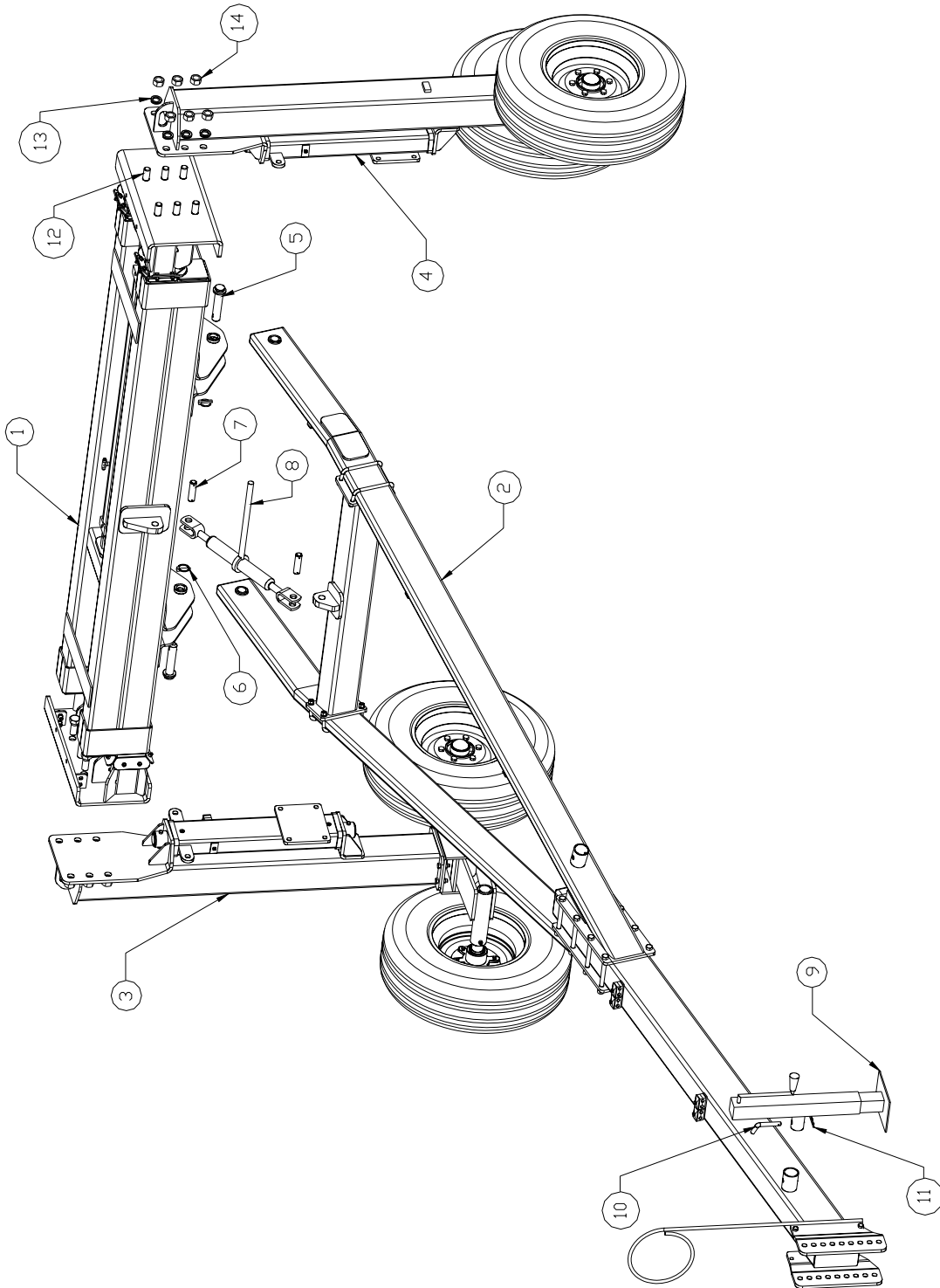

**MAIN FRAME W/ TONGUE  
LMC 8603 RAKE**

ITEM NO.	DESCRIPTION	PART NO.	QUANTITY
1	ASSEMBLY, 8603 MAIN FRAME	84-0013-86	1
2	ASSEMBLY, 8603 TONGUE	84-0016-86	1
3	ASSEMBLY, RH WHEEL POST/PIVOT	84-0012-86	1
4	ASSEMBLY, LH WHEEL POST/PIVOT	84-0011-86	1
5	PIN, 4-5/8" USABLE LENGTH TOP	79-1009-86	2
6	PIN, 7/16" DIA. LYNCH	79-061-36	2
7	PIN, CLEVIS (W/ TWO COTTER PINS)	77-003-85	2
8	JACK, SL1541 HEAVY DUTY RATCHET	79-1000-86	1
9	WELDMENT, JACK	85-1030-88	1
10	PIN, 5/8" X 3" BENT ARM	128007	1
11	PIN, #12, 3/16" X 3-1/2" HAIR	126004	1
12	BOLT, 1" X 2-1/2" GRADE 8 HEX	2818-3224	12
13	WASHER, 1" LOCK	1602-3200	12
14	NUT, 1" GRADE 8 HEX	0814-3200	12

**RIGHT HAND (9 WHEEL) RAKING ARM (#84-0025-86)**  
**LMC 8603 RAKE**

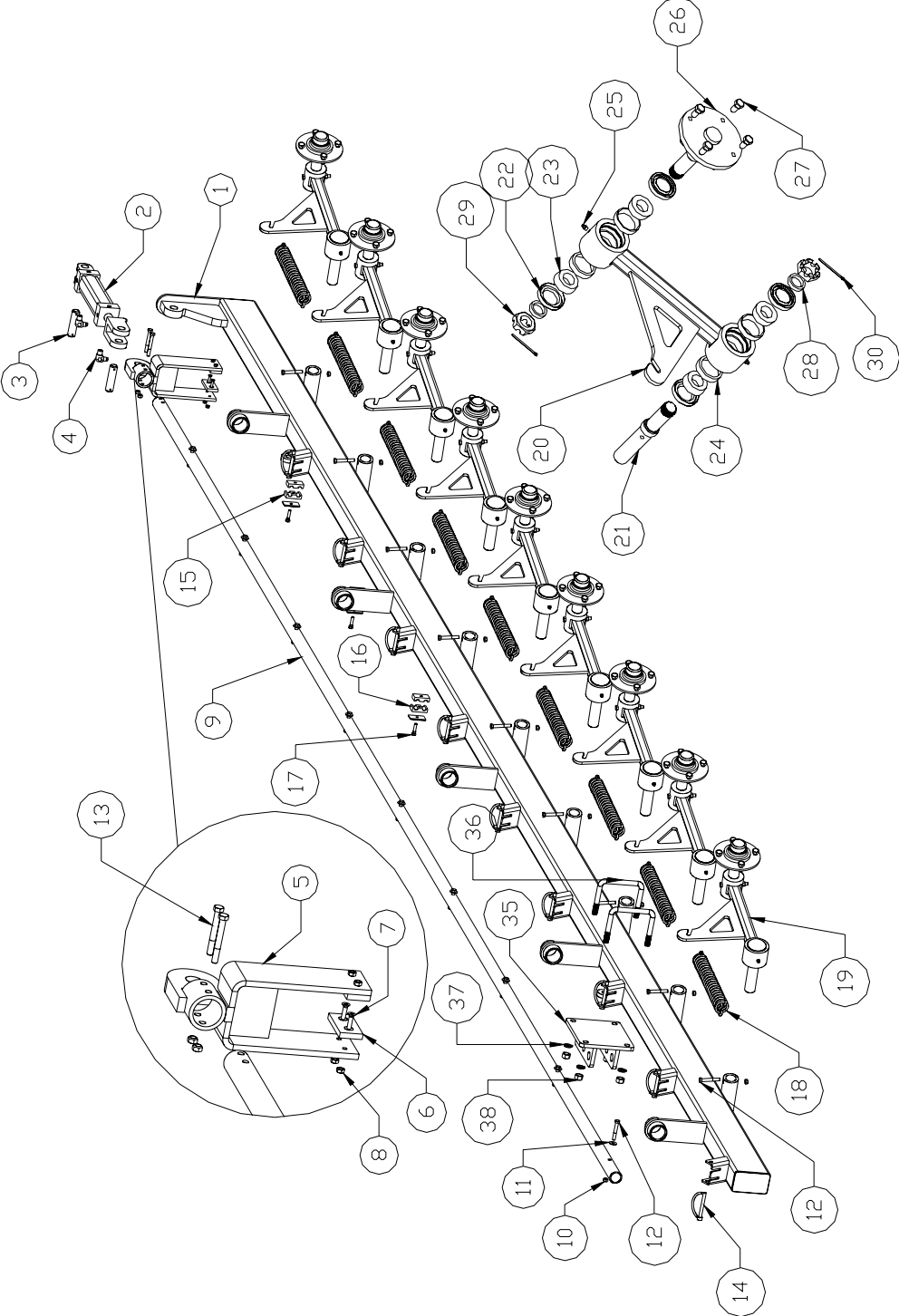

**RIGHT HAND (9 WHEEL) RAKING ARM  
LMC 8603 RAKE**

ITEM NO.	DESCRIPTION	PART NO.	QUANTITY
1	WELDMENT, 9 WHEEL RH CARRIAGE	85-0002-86	1
2	CYLINDER, 2" X 8" STROKE ASAE	79-158-88	1
3	PIN, CLEVIS (WITH TWO COTTER PINS)	77-003-85	2
4	ELBOW, #6MJ—#6MP	79-1000-88	2
5	WELDMENT, PIVOT ARM CONNECTING	85-0006-86	1
6	BEARING, HOSE TOP RACK POLY	68-1002-88	2
7	SCREW, 1/4" X 1" FLAT HEAD MACHINE	4216-0810	4
8	NUT, 1/4" STOVER HEX	1412-0800	4
9	PIPE, 9 WHEEL PIVOT ARM	92-0002-86	1
10	NUT, 3/8" STOVER HEX	1412-1200	20
11	WASHER, 3/8" TYPE A WIDE FLAT	1702-1200	9
12	BOLT, 3/8" X 2-1/2" LONG GRADE 5 HEX	2816-1224	18
13	BOLT, 3/8" X 3" LONG GRADE 5 HEX	2816-1230	2
14	PIN, 3/8" X 3" PTO LOCK	79-1016-86	9
15	CLAMP, #2127/127D TWIN HOSE	77-024-36	6
16	PLATE, CLAMP TOP COVER	77-032-38	3
17	BOLT, 5/16" X 1-3/8" LONG GRADE 5 HEX	2816-1013	3
18	ASSEMBLY, RAKING WHEEL SPRING	84-0015-86	9
	SPRING, RAKING WHEEL CUSHION	79-1007-86	1
	BAR, RAKING WHEEL SPRING PULL	96-0004-86	2
19	ASSEMBLY, RH PIVOT ARM	84-0033-86	9
20	WELDMENT, UNIVERSAL PIVOT ARM	85-0031-86	1
21	SPINDLE, 8603 PIVOT ARM	96-0006-86	1
22	SEAL, SINGLE LIP	77-006-02	4
23	BEARING, #15123	77-0006-86	4
24	CUP, L15245 RACE	77-0005-86	4
25	FITTING, 5/16" DRIVE IN GREASE	79-6441-40	1
26	WELDMENT, 8605 WHEEL SPINDLE	85-0032-86	1
27	BOLT, GW 1/2-20 X 1 LUG	77-009-36	4
28	SPACER, HUB	94-0030-86	2
29	NUT, 1-1/4" UNF CASTLE	1332-4000	2
30	PIN, 5/32" X 2-1/2" LONG COTTER	79-002-63	2
35	WELDMENT, WHEEL ARM ADJUSTING BRACKET	85-0022-86	1
36	U-BOLT, 5/8" X 5-1/8" X 4-1/2"	79-1008-86	2
37	WASHER, 5/8" REGULAR LOCK	1602-2000	4
38	NUT, 5/8" GRADE 5 HEX	0812-2000	4
NS	HOSE, 1/4" X 160" LONG RH WHEEL LOWER	79-1005-86	1
NS	HOSE, 1/4" X 170" LONG RH WHEEL RAISE	79-1006-86	1
NS	CHAIN, 1/4" PROOF COIL X 4 LINKS	78-0035-004	9
NS	CHAIN, 1/4" PROOF COIL X 22 LINKS	78-0035-022	9
NS	CHAIN, 1/4" PROOF COIL X 15 LINKS	78-0035-015	9
NS	SHACKLE, 3/8" GALV STEEL ANCHOR	79-1018-86	9

**LEFT HAND (8 WHEEL) RAKING ARM (#84-0024-86)**  
**LMC 8603 RAKE**

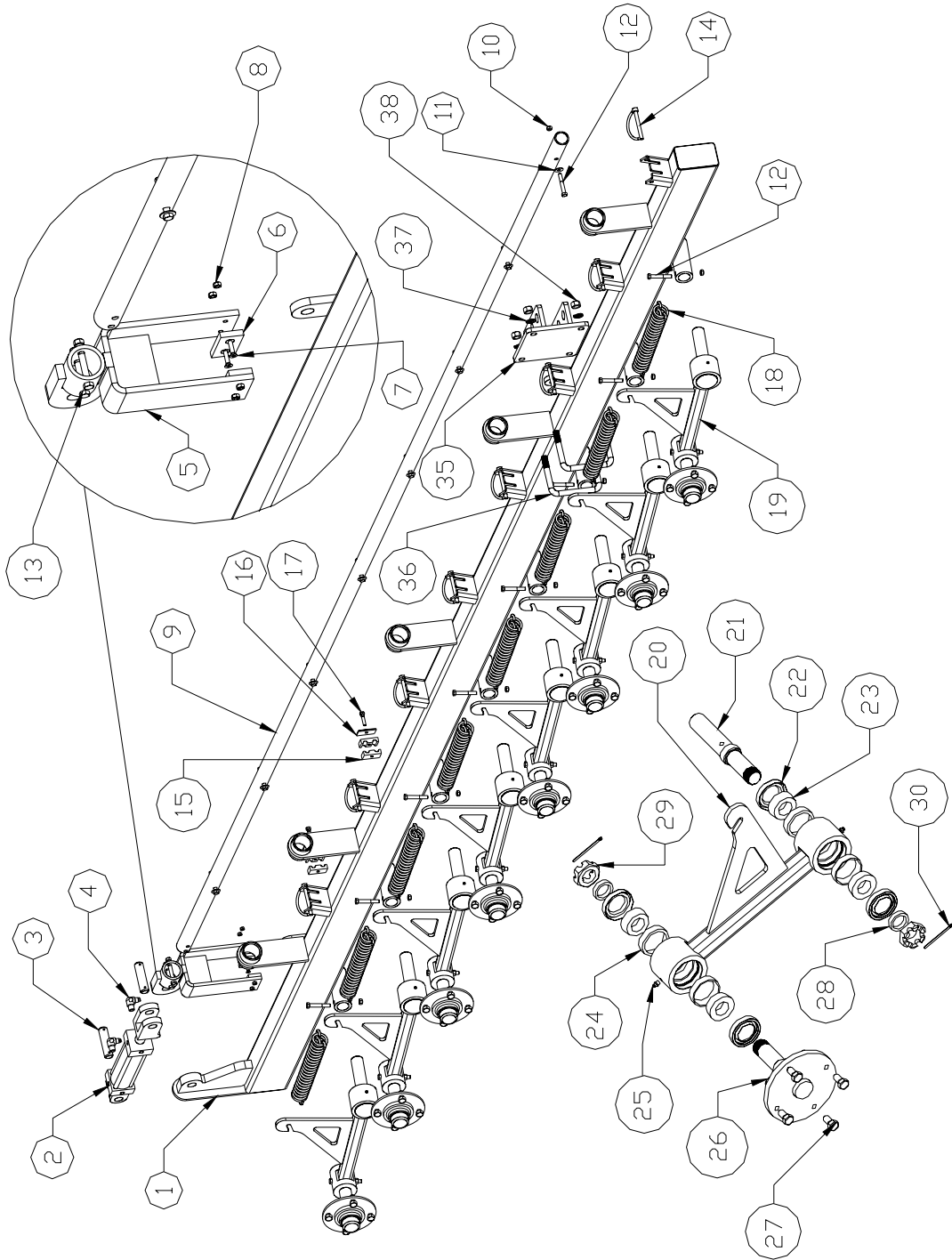

**LEFT HAND (8 WHEEL) RAKING ARM  
LMC 8603 RAKE**

ITEM NO.	DESCRIPTION	PART NO.	QUANTITY
1	WELDMENT, 8 WHEEL RH CARRIAGE	85-0001-86	1
2	CYLINDER, 2" X 8" STROKE ASAE	79-158-88	1
3	PIN, CLEVIS (WITH TWO COTTER PINS)	77-003-85	2
4	ELBOW, #6MJ—#6MP	79-1000-88	2
5	WELDMENT, PIVOT ARM CONNECTING	85-0006-86	1
6	BEARING, HOSE TOP RACK POLY	68-1002-88	2
7	SCREW, 1/4" X 1" FLAT HEAD MACHINE	4216-0810	4
8	NUT, 1/4" STOVER HEX	1412-0800	4
9	PIPE, 8 WHEEL PIVOT ARM	92-0003-86	1
10	NUT, 3/8" STOVER HEX	1412-1200	18
11	WASHER, 3/8" TYPE A WIDE FLAT	1702-1200	8
12	BOLT, 3/8" X 2-1/2" LONG GRADE 5 HEX	2816-1224	16
13	BOLT, 3/8" X 3" LONG GRADE 5 HEX	2816-1230	2
14	PIN, 3/8" X 3" PTO LOCK	79-1016-86	8
15	CLAMP, #2127/127D TWIN HOSE	77-024-36	4
16	PLATE, CLAMP TOP COVER	77-032-38	2
17	BOLT, 5/16" X 1-3/8" LONG GRADE 5 HEX	2816-1013	2
18	ASSEMBLY, RAKING WHEEL SPRING	84-0015-86	8
	SPRING, RAKING WHEEL CUSHION	79-1007-86	1
	BAR, RAKING WHEEL SPRING PULL	96-0004-86	2
19	ASSEMBLY, LH PIVOT ARM	84-0032-86	8
20	WELDMENT, WHEEL PIVOT ARM	85-0031-86	1
21	SPINDLE, 8603 PIVOT ARM	96-0006-86	1
22	SEAL, SINGLE LIP	77-006-02	4
23	BEARING, #15123	77-0006-86	4
24	CUP, 15245 RACE	77-0005-86	4
25	FITTING, 5/16" DRIVE IN GREASE	79-6441-40	2
26	WELDMENT, 8605 WHEEL SPINDLE	85-0032-86	1
27	BOLT, GW 1/2-20 X 1 LUG	77-009-36	4
28	SPACER, HUB	94-0030-86	2
29	NUT 1-1/4" UNF CASTLE	1332-4000	2
30	PIN, 5/32" X 2-1/2" LONG COTTER	79-002-63	2
35	WELDMENT, WHEEL ARM ADJUSING BRACKET	85-0022-86	1
36	U-BOLT, 5/8" X 5-1/8" X 4-1/2"	79-1008-86	2
37	WASHER, 5/8" REGULAR LOCK	1602-2000	4
38	NUT, 5/8" GRADE 5 HEX	0812-2000	4
NS	HOSE, 1/4" X 130" LONG RH WHEEL LOWER	79-1012-86	1
NS	HOSE, 1/4" X 140" LONG RH WHEEL RAISE	79-1013-86	1
NS	CHAIN, 1/4" PROOF COIL X 4 LINKS	78-0035-004	8
NS	CHAIN, 1/4" PROOF COIL X 22 LINKS	78-0035-022	8
NS	CHAIN, 1/4" PROOF COIL X 15 LINKS	78-0035-015	8
NS	SHACKLE, 3/8" GALV STEEL ANCHOR	79-1018-86	8

## RIGHT HAND (9 WHEEL) RAKING ARM MOUNT LMC 8603 RAKE

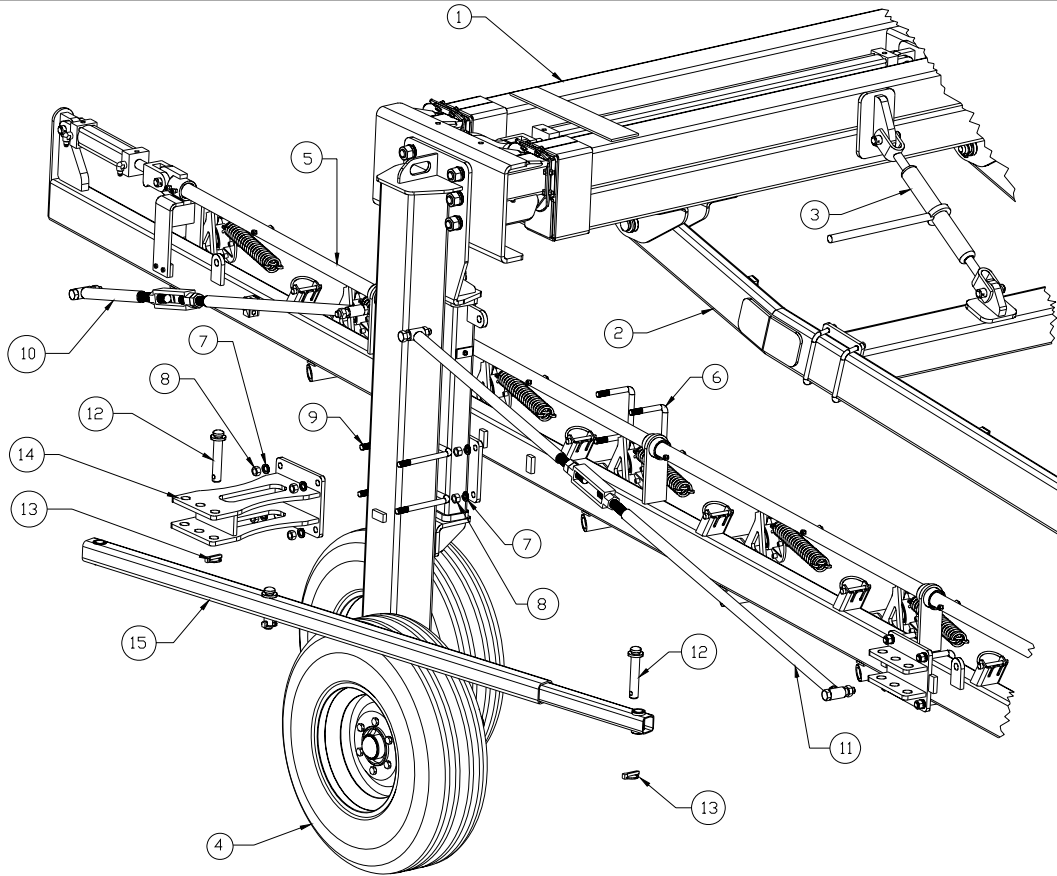

ITEM NO.	DESCRIPTION	PART NO.	QUANTITY
1	ASSEMBLY, 8603 MAIN FRAME	84-0013-86	1
2	ASSEMBLY, 8603 TONGUE	84-0016-86	1
3	JACK, SL1541 HEAVY DUTY RATCHET	79-1000-86	1
4	ASSEMBLY, RH WHEEL POST/PIVOT	84-0012-86	1
5	ASSEMBLY, 9 WHEEL RH CARRIAGE	84-0004-86	1
6	U-BOLT, 5/8" X 5-1/8" X 4-1/2"	79-1008-86	2
7	WASHER, 5/8" REGULAR LOCK	1602-2000	8
8	NUT, 5/8" GRADE 5 HEX	0812-2000	8
9	U-BOLT, 5/8" X 6-3/8" X 7-1/2"	79-1014-86	2
10	ASSEMBLY, RH REAR TRUSS ROD	84-013-87	1
	TURNBUCKLE, 1" THREAD X 6" LONG	79-051-90	1
	NUT, 3/4" STOVER HEX	1412-2400	2
	BOLT, 3/4" X 3-1/2" GRADE 5 HEX	2816-2434	2
11	ASSEMBLY, FRONT TRUSS ROD	84-012-87	1
	TURNBUCKLE, 1" THREAD X 6" LONG	79-051-90	1
	NUT, 3/4" STOVER HEX	1412-2400	2
	BOLT, 3/4" X 3-1/2" GRADE 5 HEX	2816-2434	2
12	PIN, 4-3/8" USABLE LENGTH	79-1015-86	2
13	PIN, 7/16" DIAMETER LYNCH	79-061-36	2
14	WELDMENT, WHEEL ARM ADJUSTING BRACKET	85-0023-86	1
15	ASSEMBLY, ADJUSTING ARM	84-0018-86	1
	WELDMENT, ADJUSTING ARM SHORT	85-0024-86	1
	WELDMENT, ADJUSTING ARM LONG	85-0025-86	1
	PIN, 3" USABLE LENGTH	79-1017-86	1
	PIN 7/16" DIA LYNCH	79-061-38	1



## LEFT HAND (8 WHEEL) RAKING ARM MOUNT LMC 8603 RAKE

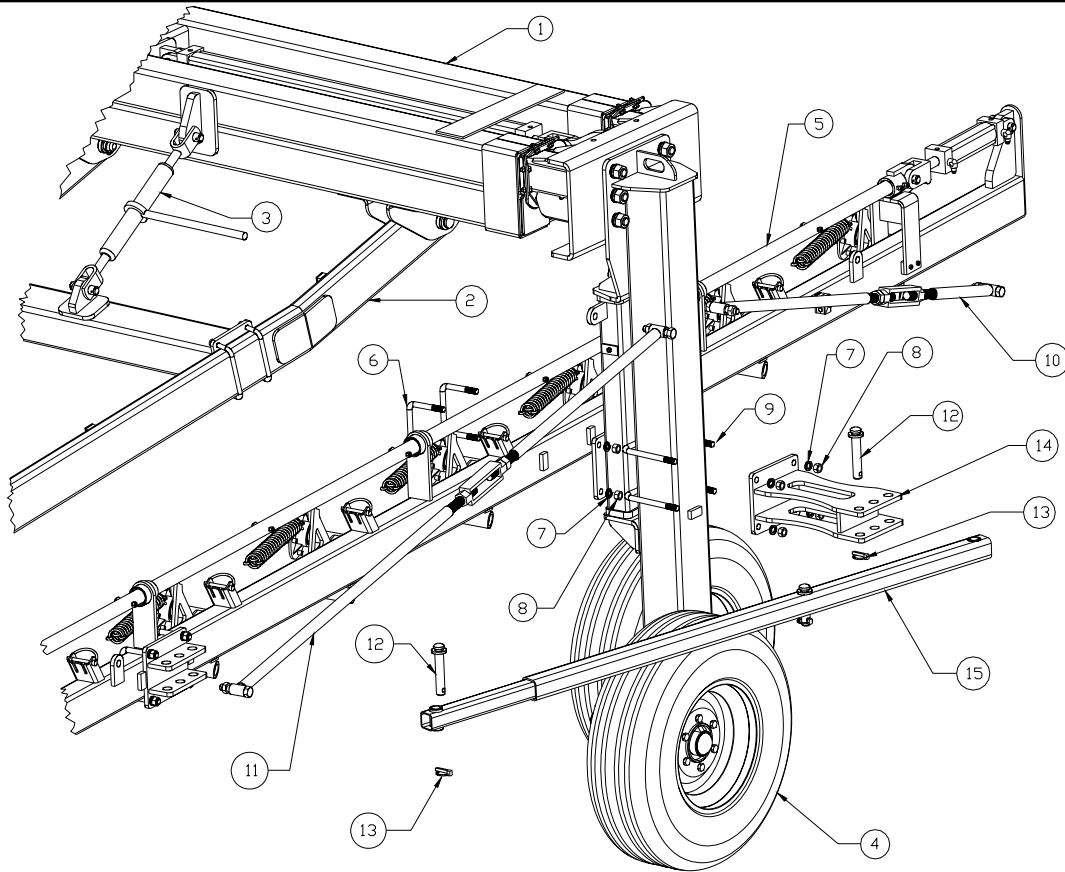

ITEM NO.	DESCRIPTION	PART NO.	QUANTITY
1	ASSEMBLY, 8603 MAIN FRAME	84-0013-86	1
2	ASSEMBLY, 8603 TONGUE	84-0016-86	1
3	JACK, SL1541 HEAVY DUTY RATCHET	79-1000-86	1
4	ASSEMBLY, LH WHEEL POST/PIVOT	84-0011-86	1
5	ASSEMBLY, 8 WHEEL LH CARRIAGE	84-0003-86	1
6	U-BOLT, 5/8" X 5-1/8" X 4-1/2"	79-1008-86	2
7	WASHER, 5/8" REGULAR LOCK	1602-2000	8
8	NUT, 5/8" GRADE 5 HEX	0812-2000	8
9	U-BOLT, 5/8" X 6-3/8" X 7-1/2"	79-1014-86	2
10	ASSEMBLY, LH REAR TRUSS ROD	84-0017-86	1
	TURNBUCKLE, 1" THREAD X 6" LONG	79-051-90	1
	NUT, 3/4" STOVER HEX	1412-2400	2
	BOLT, 3/4" X 3-1/2" GRADE 5 HEX	2816-2434	2
11	ASSEMBLY, FRONT TRUSS ROD	84-012-87	1
	TURNBUCKLE, 1" THREAD X 6" LONG	79-051-90	1
	NUT, 3/4" STOVER HEX	1412-2400	2
	BOLT, 3/4" X 3-1/2" GRADE 5 HEX	2816-2434	2
12	PIN, 4-3/8" USABLE LENGTH	79-1015-86	2
13	PIN, 7/16" DIAMETER LYNCH	79-061-36	2
14	WELDMENT, WHEEL ARM ADJUSTING BRACKET	85-0023-86	1
15	ASSEMBLY, ADJUSTING ARM	84-0018-86	1
	WELDMENT, ADJUSTING ARM SHORT	85-0024-86	1
	WELDMENT, ADJUSTING ARM LONG	85-0025-86	1
	PIN, 3" USABLE LENGTH	79-1017-86	1
	PIN 7/16" DIA LYNCH	79-061-38	1

## RAKING WHEEL DETAIL LMC 8603 RAKE

AS SHOWN FOR  
RH RAKING WHEEL

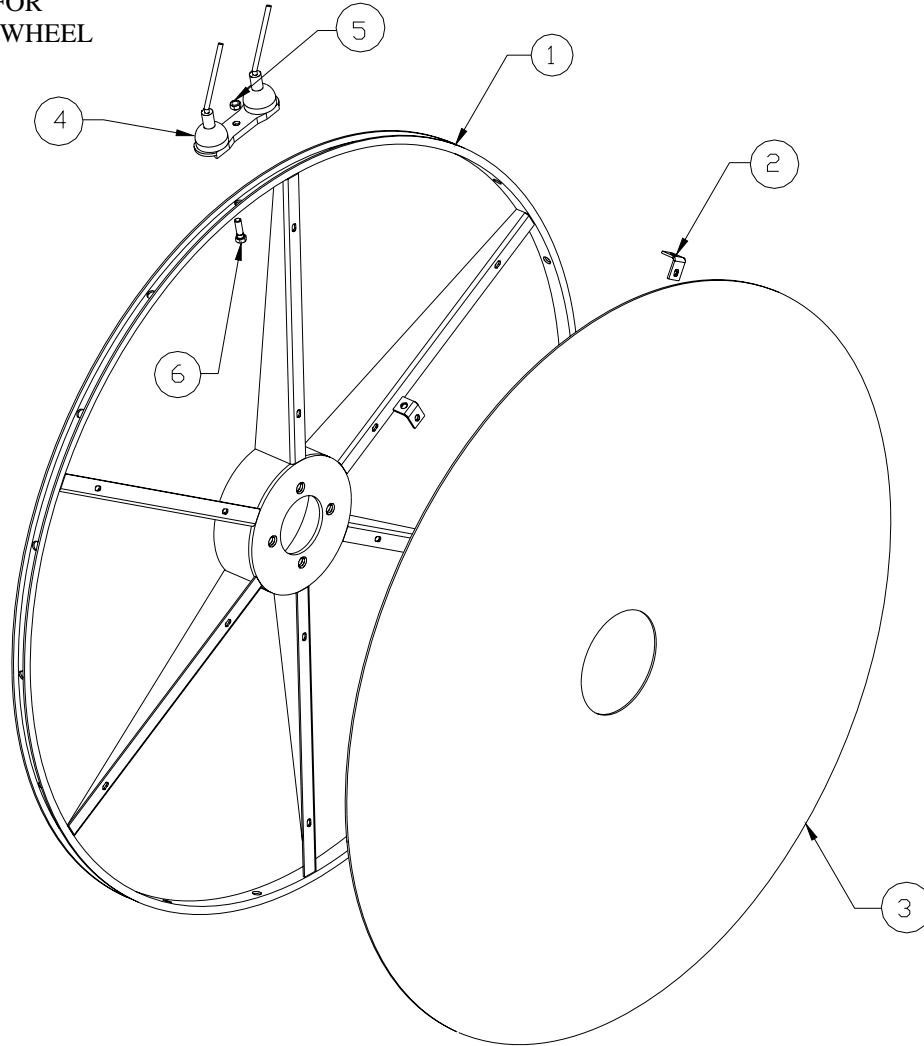

ITEM NO.	DESCRIPTION	PART NO.	QUANTITY
1	WELDMENT, STANDARD RAKING WHEEL	85-001-87	1
	WELDMENT, RE-INFORCED RAKEING WHEEL (OPTIONAL ON LEADING WHEELS ONLY)	85-1000-87	OPTIONAL
2	MOUNTING CLIP	98-023-87	6
3	DISC, POLY WHEEL COVER	68-1003-87	1
4	TINE, DOUBLE TOOTH	79-001-87	18
5	NUT, 3/8" STOVER HEX	1412-1200	18
6	BOLT, 3/8" X 1-1/4" GRADE 5 HEX	2816-1212	18
NS	BOLT, 1/4" X 3/4" CARRIAGE	0516-0806	18
NS	WASHER, 5/16" FLAT	1702-1000	18
NS	NUT, 1/4" STOVER HEX	1412-0800	18
	ASSEMBLY, RH RE-INFORCED RAKING WHEEL	84-1003-87	OPTIONAL
	ASSEMBLY, LH RE--INFORCED RAKING WHEEL	84-1004-87	OPTIONAL
	ASSEMBLY, RH RAKING WHEEL	84-1001-87	9 / 8
	ASSEMBLY, LH RAKING WHEEL	84-1002-87	8 / 7

## HYDRAULIC SCHEMATIC LMC 8603 RAKE

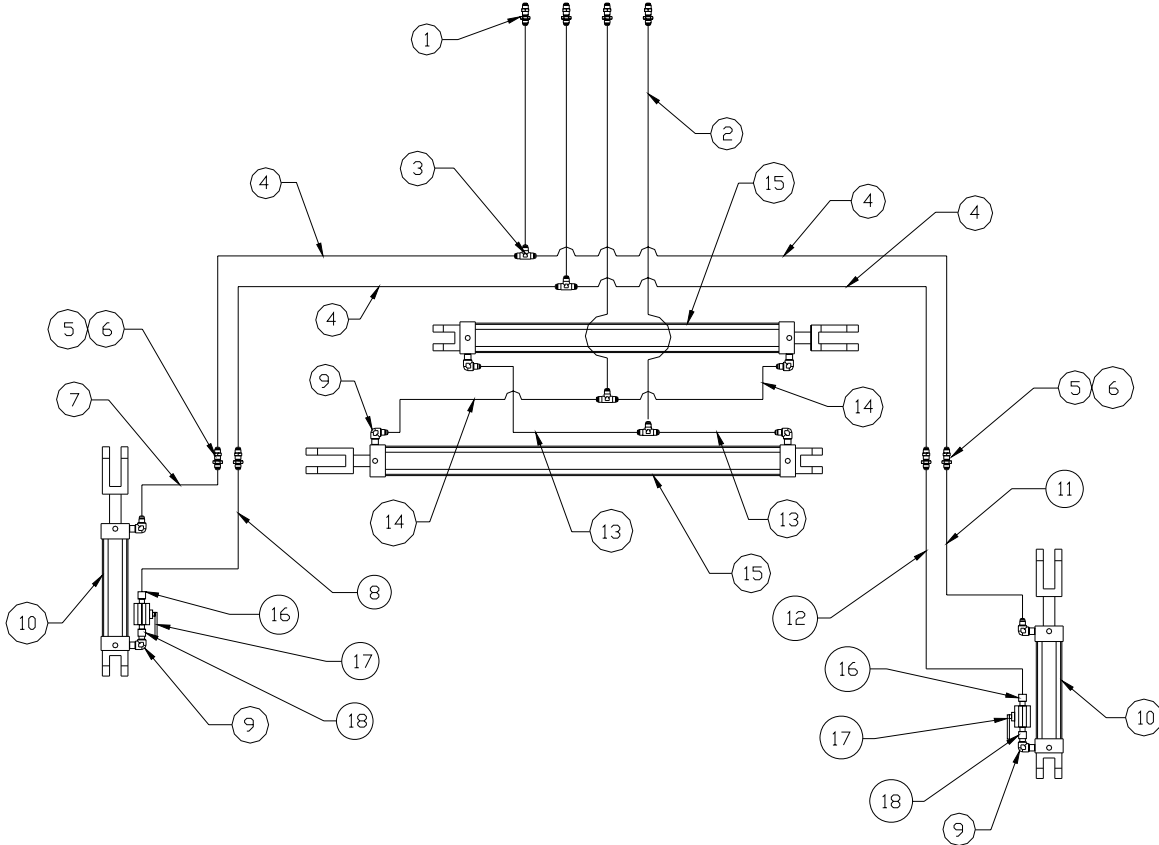

ITEM NO.	DESCRIPTION	PART NO.	QUANTITY
1	ADAPTOR, QUICK DISCONNECT	79-212-36	4
2	HOSE, 1/4" X 310" LONG SUPPLY	79-1011-86	4
3	TEE, #6MJ—#6MJ—#6MJ	79-014-20	4
4	HOSE, 1/4" X 112" LONG WHEEL LIFT	79-1004-86	4
5	FITTING, #6 BULKHEAD	79-013-88	4
6	NUT, #6 BULKHEAD LOCK	79-1002-88	4
7	HOSE, 1/4" X 130" LONG LH WHEEL LOWER	79-1012-86	1
8	HOSE, 1/4" X 140" LONG LH WHEEL RAISE	79-1013-86	1
9	ELBOW, #6MJ—#6MP 90 DEGREE	79-1000-88	8
10	CYLINDER, 2 X 8 ASAE	79-158-88	2
11	HOSE, 1/4" X 160" LONG RH WHEEL LOWER	79-1005-86	1
12	HOSE, 1/4" X 170" LONG RH WHEEL RAISE	79-1006-86	1
13	HOSE, 1/4" X 9" LONG CYLINDER EXTEND	79-1002-86	2
14	HOSE, 1/4" X 40" LONG CYLINDER RETRACT	79-1003-86	2
15	CYLINDER, 2-1/2" X 48" STROKE	79-1023-86	2
16	ADAPTOR, #6MJ—#6MP STRAIGHT	79-1001-88	2
17	VALVE, 3/8" NPT BALL	79-1050-88	2
18	ADAPTOR, #6MP—#6FJS STRAIGHT	79-1051-88	2

## EXTENSION ARM CYLINDER LMC 8603 RAKE

79-1023-86

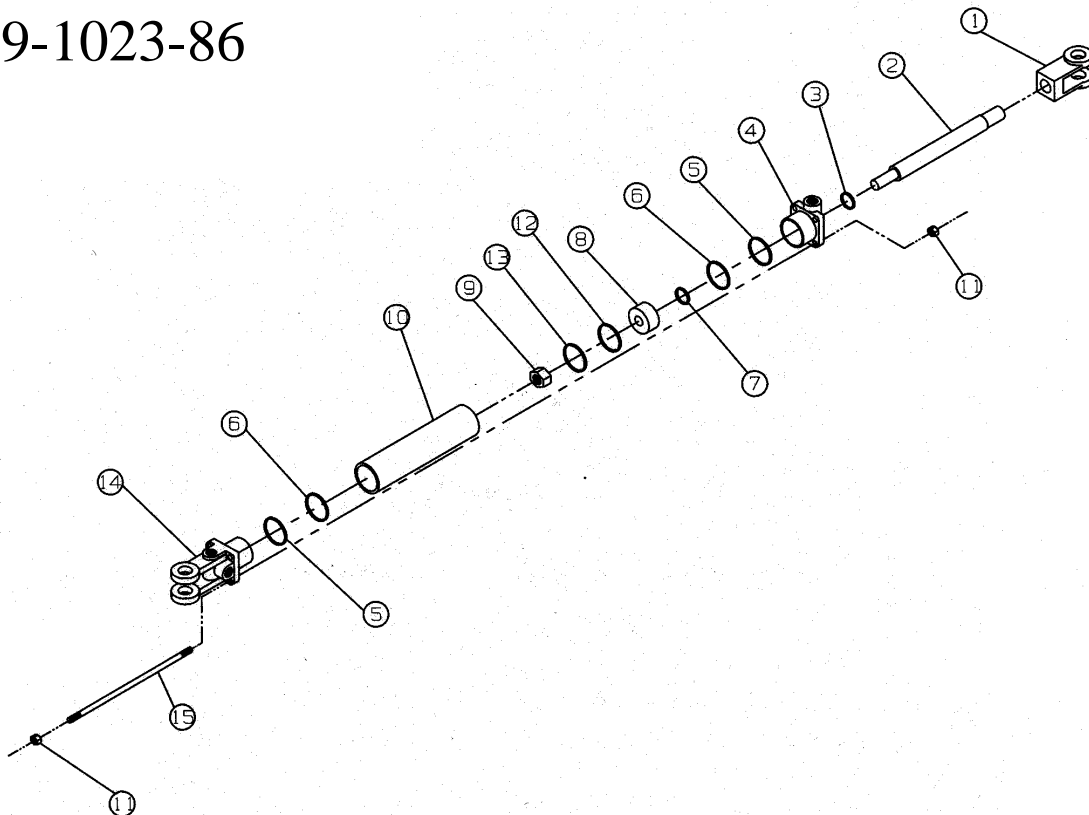

ITEM NO.	DESCRIPTION	PART NO.	QUANTITY
1	ROD CLEVIS	77-1035-88	2
2	CYLINDER ROD	77-0001-86	2
3	SEAL	77-1037-88	2
4	ROD CAP	77-1038-88	2
5	BACKUP WASHER	77-1039-88	4
6	O-RING	77-1040-88	4
7	ROD SEAL	77-1041-88	2
8	PISTON	77-1042-88	2
9	NUT, 3/4" UNF HEX LOCK	1411-2400	2
10	BARREL	77-0002-86	2
11	NUT, 3/8" HEX	0811-1200	16
12	O-RING	77-1044-88	2
13	PISTON RING	77-1045-88	2
14	CLEVIS CAP	77-1046-88	2
15	TIE ROD	77-0003-86	8
NOT SHOWN	SEAL KIT	77-0004-86	2

## WHEEL LIFT CYLINDER LMC 8603 RAKE

79-158-88

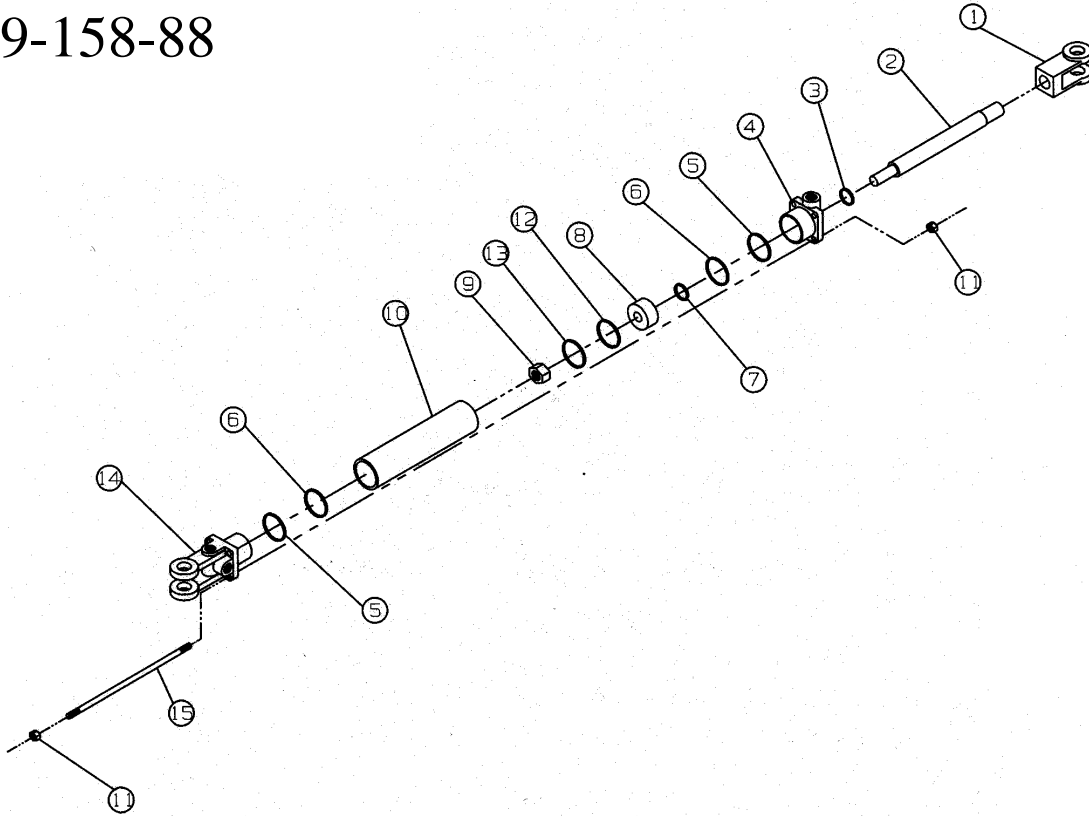

ITEM NO.	DESCRIPTION	PART NO.	QUANTITY
1	ROD CLEVIS	77-133-88	2
2	CYLINDER ROD	77-134-88	2
3	SEAL	77-135-88	2
4	ROD CAP	77-136-88	2
5	BACKUP WASHER	77-137-88	4
6	O-RING	77-138-88	4
7	ROD SEAL	77-139-88	2
8	PISTON	77-140-88	2
9	NUT, 3/4" UNF HEX LOCK	1411-2400	2
10	BARREL	77-141-88	2
11	NUT, 3/8" HEX	0811-1200	16
12	O-RING	77-142-88	2
13	PISTON RING	77-143-88	2
14	CLEVIS CAP	77-144-88	2
15	TIE ROD	77-145-88	8
NOT SHOWN	SEAL KIT	77-152-88	2

**NOTES**

**NOTES**

## MAINTENANCE RECORD

DATE SERVICED	SERVICE PERFORMED	PARTS REPLACED