



**ULTIMATE**  
COLLISION EQUIPMENT

Sales, Service, and Training  
240-749-9042  
[sales@ultimatecollisionequipment.com](mailto:sales@ultimatecollisionequipment.com)



## GYSPT INVERTER **PTI.G**

**The spot welder of the future**

Proudly distributed by Ultimate Collision Equipment



## GYSPTI.G

MADE IN FRANCE

# The spot welder of tomorrow

Designed for assembling multiple grades of steel (UHLE, THLE, HLE and Boron), the GYSPTI.G spot welder has it all: a motorised, overhanging arm offering a 120 cm operating range, a clamping system with a built-in transformer and a pneumatic over-opening system. Each of the machine's updated and improved component parts makes it even easier for operators

to access the narrowest areas whilst also doubling productivity. Equipped with on-board intelligence, its cutting-edge technology is now, more than ever, able to satisfy the needs of professional panel beaters and car manufacturers.

- 024854: 220 V
- 024878: 400 V
- 024892: 480 V



### Motorised, ultra-ergonomic arm

- Upto 120cm operating range.
- Height adjustable from 159 - 253 cm.
- Provides easy access to the workspace.
- More stability thanks to its repositioned front wheels.

### One of the only high-tech clamping systems on the market

- Built-in, water-cooled transformer.
- Electrode over-opens in less than two seconds.
- Automatic connection to the arm's water-cooling system.
- Features 360° rotation with a built-in gyroscope.
- A compact gun weighing only 11.3 kg.
- Electrode-clamping force of 550 daN.
- Compact and user-friendly.
- Non-adjustable clamp connector and arm connector.

Six-metre long cable.

### A smart power source that boasts real strength

- Welding current of upto 14,500 A.
- Automatic, pre-installed welding settings.
- Higher tack-welding rate (18 points/min).
- Fully traceable spot welds.

# Adjustable arm |

Manoeuvrable, adjustable and motor driven; the new arm allows the gun's height to be tailored to any working situation.

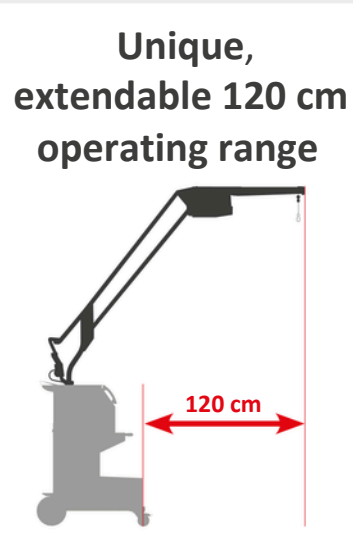

**Foldable**



**30° rotation**

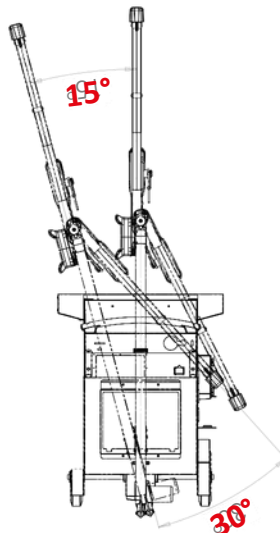

**Adjustable**



# A clamping system featuring a built-in transformer

Our new, compact G-clamp is fitted with a new-generation, water-cooled transformer. Easy to handle and ultra-light at only 11.3 kg, this machine offers an automatic electrode over-opening system for quick access to the welding area.

Pre-installed, automatic welding settings (AUTO mode) make it extremely easy to use.



A simple,  
lightweight  
and  
effective  
clamp!

## QUICK OVER-OPENING

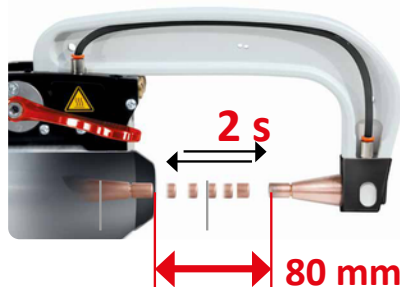

## BUILT-IN GYROSCOPE



## PERFECT CONTACT

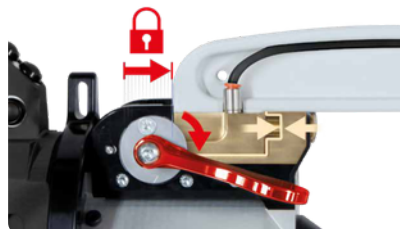

## AUTO



# Features and benefits

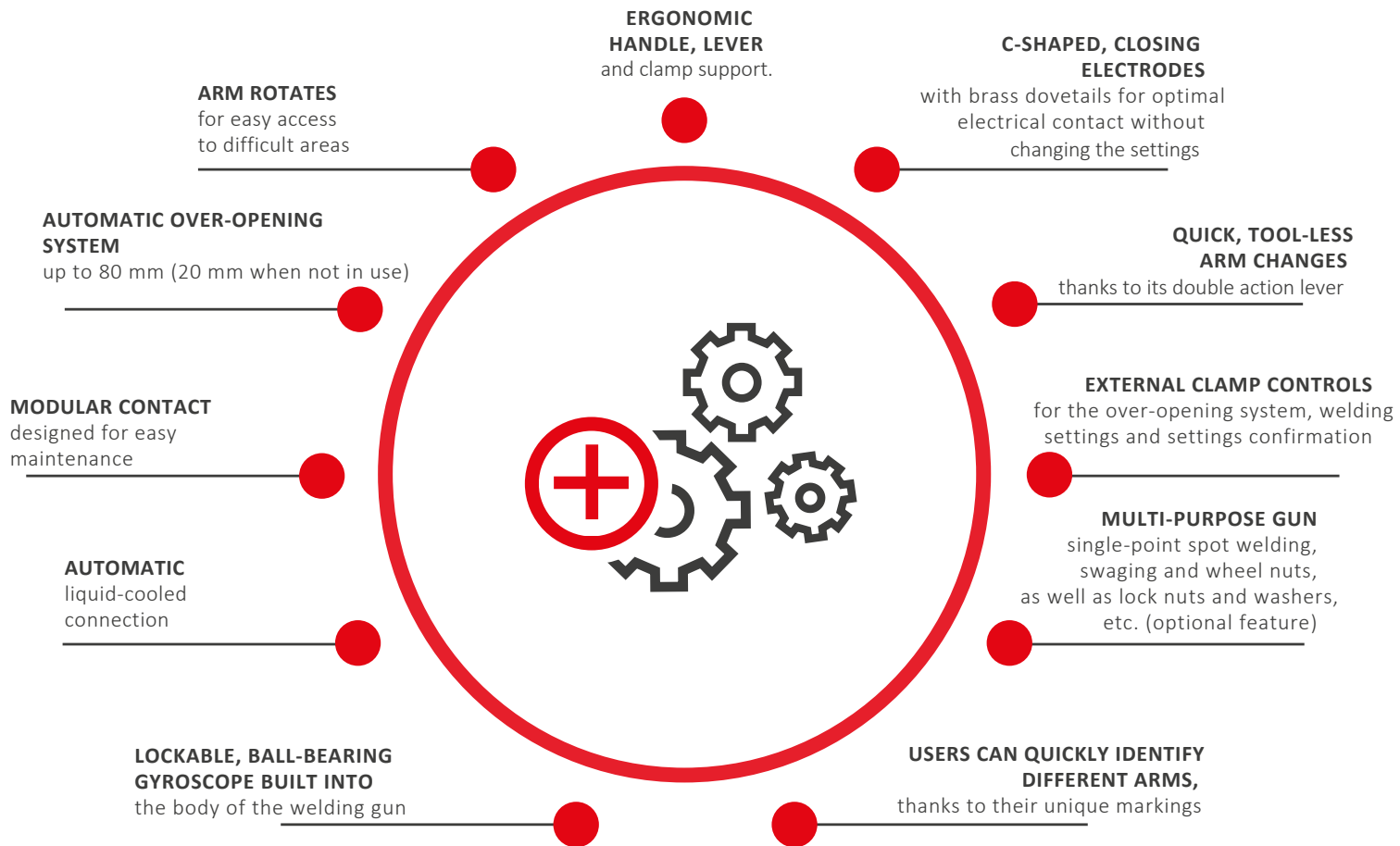

Fully compliant with electromagnetic safety standards

## High-performance equipment



- Welding current: up to 14,500 A
- Clamping force: 8 bar/550 daN
- Liquid-cooled power cables, transformer, bridge-connected diodes, electrodes and caps
- Maximum productivity thanks to the G-clamp's cylinder's updated design and welding algorithm
- Simple browsing thanks to its 5.7" LCD screen
- Automatic pressure regulation between the electrodes
- Spot-weld counter to establish the cap's lifespan
- Special welding features for bonded sheet metal and metal with difficult-to-weld coatings

# Easy to use

## A simple and intuitive interface designed specially for users

Our innovative inverter automatically determines the type of steel and the thickness of the sheets, as well as the presence of glue and insulating material between the HLE/THLE, UHLE and boron sheets. It can even work out the exact amount of current and clamping force required for a 100% reliable weld.



# Certification & Traceability

## Traceability, an essential requirement for manufacturer approval



- Providing a full record of the weld points performed is essential
- Each weld point is saved on the SD card and can be played back on a PC to generate a welding report
- This allows the operator to demonstrate the quality of their work
- It is important to respect the manufacturer's guidelines in order to guarantee the safety of motorists
- Playback recorded reports on a PC

## The PTI.G offers you off-the-shelf software so you can easily evaluate your welding data

- Records, edits, saves and exports welding data for accurate repair reports
- A spot-weld counter indicates when a replacement cap is required

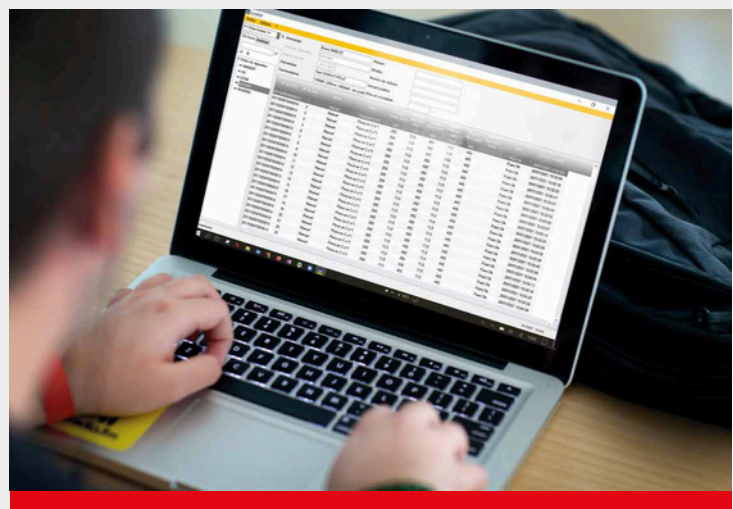

# G ARMS, THE FULL RANGE

## G9ARM, THE ONLY ONE OF ITS KIND

The G9arm transforms the electrode clamp from a C shape to an X shape. Patented for being easy to use alongside its highly ergonomic design, it allows the operator to use the GYSPOT PTI.G's AUTO mode to automatically determine all the welding-point settings (*the G9 arm is an optional feature*).

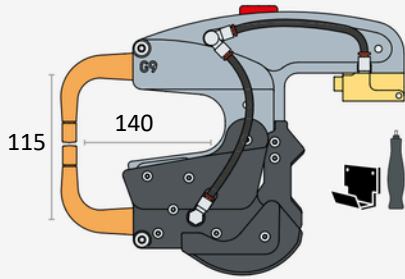

**G9 + X1 -550 daN**  
022881

**X1 -550 daN**  
505010

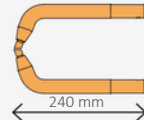

**X2 -** 050518

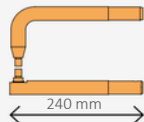

**X6 -** 050587

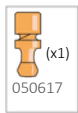

**G2 - 8bar/300 daN**  
022775

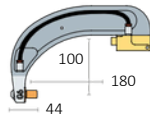

**G6 - 8bar/550 daN**  
022812

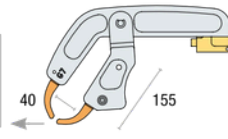

**G7 - 4bar/150 daN**  
022829

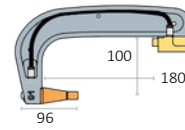

**G1 - 8bar/550 daN**  
022768

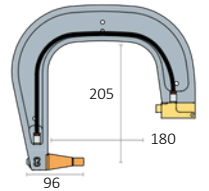

**G3 - 8bar/550 daN**  
022782

**G1/G3-SA (Small Access)**

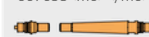

(for arms > 02/2021)

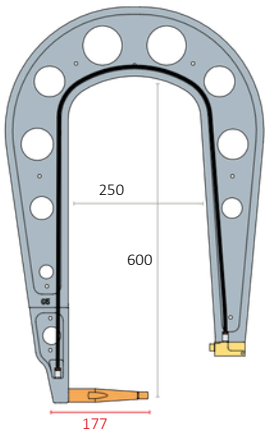
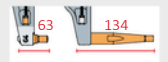

**G5 - 8bar/550 daN**  
022805

□ : 6.25 kg

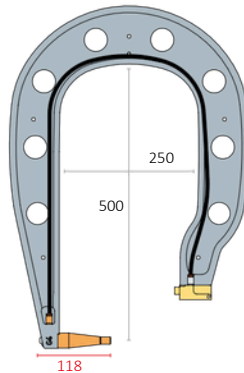

**G4 - 8bar/550 daN**  
022799

**G4-SA (Small Access)**

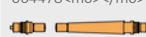

(for arms < 10/2019)

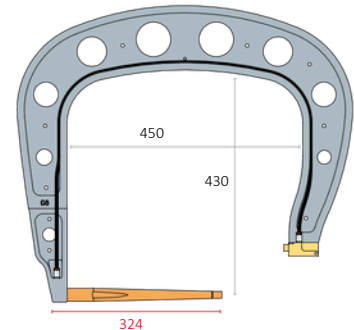

**G8 - 8bar/550 daN**  
022836

**G8-SA (Small Access)**

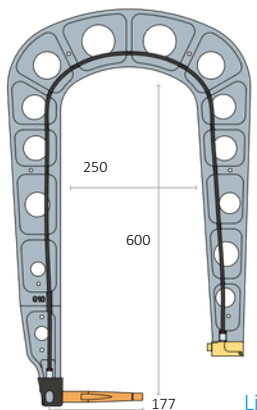
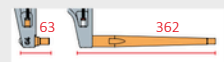
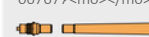

**G10 - 8bar/400daN**  
067165

Lightweight  
: 5 kg

**G5-G10-SA (Small Access)**



### Small Access:

Small-access electrodes provide access to confined areas within the car's bodywork.

## Storing the arms

The PTI.G spot welder has special brackets at the back allowing up to five G arms to be safely stored.

What's more, the additional side bracket also provides storage for a G9 arm.

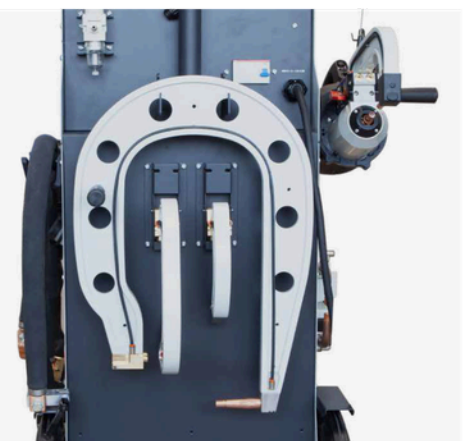

# Features and technical data



Sales, Service, and Training  
240-749-9042  
sales@ultimatecollisionequipment.com

024854

024878

024892

## FEATURES

Electrical installation	3 x 208-240 V	3 x 400 V ±10%	3 x 480 V ±10%
Mains frequency	50/60 Hz		
Breaker	40 delayed-action or type-D circuit breakers	25 delayed-action or type-D circuit breakers	20 delayed-action or type-D circuit breakers
Protection type	IP 20		
Cooling system	Water cooled		
Compressed-air supply, P1min-P1max	8-10 bars (116-145 psi)		
Max. short-circuit input current, ILCC	240 A - 230 A (208 V-240 V)	139 A	116 A
Instantaneous max. apparent power (Smax)	83 kVA-96 kVA (208 V-240 V)	96 kVA	96 kVA
Clamping force, Fmin-Fmax	100-550 daN (225-1236 lbf)		
Dimensions (HxWxD) approx.	1200 x 710 x 900 mm		
Weight	100 kg		

## WELDING OUTPUT

Max. short-circuit output current, I2CC	12.5 kA - 14.5 kA (208 V-240 V)	14.5 kA	14.5 kA
No load voltage	6.6 V - 7.9 V (208 V-240 V)	7 V	7 V

## LIQUID COOLING

Tank capacity	30 litres
Nominal coolant-flow rate, Q	2.3 l/min

## CLAMP

Type	360° gyroscopic design
Clamp controls	Yes (over-opening, welding, settings confirmation)
Over opening (retractable electrode)	Yes (from 20 mm to 80 mm)
Over-opening speed	Two seconds
X-clamp	Yes (with the G9 arm option) - automatic welding for X1, X2 and X3
Automatic inter-electrode pressure adjustment	Yes
Quick-coupling cooling circuit	Yes
Electrically insulated arms (insulating paint)	Yes
Single-point welding gun	Yes (optional)
Length of clamp's cable	6 m
Standard arms	G1
Types of available G arm	G1 - G2 - G3 - G4 - G5 - G6 - G7 - G8 - G9 - G10
Reversible arm	G1 - G3 - G4 - G5 - G8 - G10

## HMI - SOFTWARE

Number of MODES	7
Manual MODE	Yes
Design MODE	Yes
Automatic MODE	Yes
Display	5.7" LCD screen
Spot-weld counting	Yes
Welding reports	Yes
Traceability	Yes

## OVERHANGING ARM

Type of overhanging arm	Articulated / Motorised with balancer
Overhanging arm's reach	120 cm
Maximum reach	250 cm
Length of cables	6 m
Display	250 cm
Spot-weld counting	160 cm



Sales, Service, and Training  
240-749-9042  
sales@ultimatecollisionequipment.com

[www.ultimatecollisionequipment.com](http://www.ultimatecollisionequipment.com)

Office: 240-749-9042