

SLEEVE ANCHORS



ASA-R- STAINLESS STEEL A2

#PREMIUM **

FEATURES

HIGH QUALITY PRE-ASSEMBLED SLEEVE ANCHOR FOR EASY AND FAST INSTALLATION .
 SUITABLE FOR DIFFERENT BASE MATERIALS AND TEMPORARY FIXINGS.
 THROUGH FIXTURE INSTALLATION
 WIDE RANGE OF ANCHOR LENGTHS
 TORQUE CONTROLLED EXPANSION
 SMALL EDGE AND SPACE DISTANCES.

APPLICATIONS

STADIUM SEATING
 RADIATORS
 SATELLITE DISHES
 SIGNS
 SHUTTERS
 STEEL CONSTRUCTIONS
 MACHINES
 PROFILE
 SUBSTRUCTURES
 GARAGE DOORS

SUITABLE BASE MATERIAL

CRACKED CONCRETE
 NON-CRACKED CONCRETE
 NATURAL STONE
 BLOCKWORK
 BRICKWORK

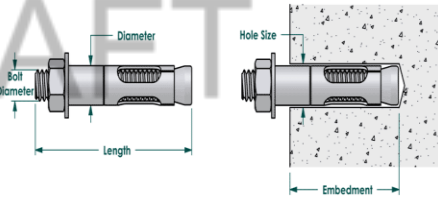
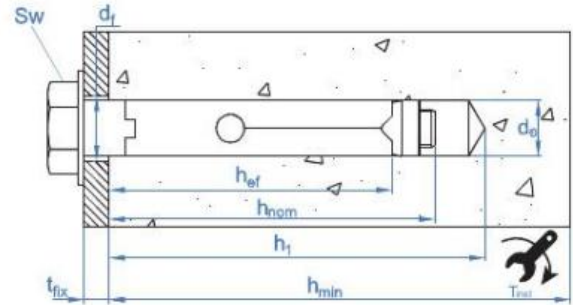

PROJECTION TYPE

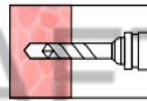

Drill a hole of required diameter and depth.

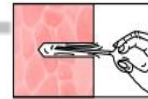

Clean the hole with brush & blowout pump.

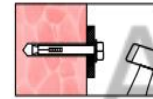

Drive anchor carefully with hammer into the hole until nut and washer are flush with the fixture.

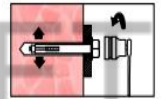

Tighten the anchor to the specified torque.

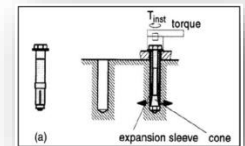

ASA-R- STAINLESS STEEL A2 **

CODE	ART NO.	BOLT DIA MM	ANCHOR LENGTH MM	DRILL HOLE Ø MM IN STRUCTURE S	T FIX MAX. MM	EFFECTIVE EMBEDDED DEPTH . MM	MIN . DRILL HOLE DEPTH MM	RECOMME NDED TORQUE (NM)	RECOMMENDED LOAD KN UNCRACKED CONCRETE C20/25		DISTANCE BETWEEN ANCHORS (MM)
									TENSILE	SHEAR	
ASA-SR-06050	3327750	6	50	10	5	40	50	12	3.5	4.0	65
ASA-SR-06060	3327751	6	60	10	10	40	50	12	3.5	4.0	65
ASA-SR-06080	3327752	6	80	10	20	40	50	12	3.5	4.0	65
ASA-SR-08060	3327753	8	60	12	5	50	60	35	4.5	5.0	80
ASA-SR-08075	3327754	8	75	12	15	50	60	35	4.5	5.0	80
ASA-SR-08100	3327755	8	100	12	20	50	60	35	4.5	5.0	80
ASA-SR-10070	3327760	10	70	14	10	60	70	70	7.0	8.0	100
ASA-SR-10080	3327761	10	80	14	25	65	70	70	7.0	8.0	100
ASA-SR-10110	3327762	10	110	14	40	80	70	70	7.0	8.0	100

NOTE:

*ALL LOAD TOLERANCES CAN BE ACHIEVED IN ACCORDANCE WITH THE SPECIFIED DIMENSIONS MENTIONED ABOVE.
 **ANY MODIFICATIONS TO THE PRODUCT PORTFOLIO CAN BE IMPLEMENTED WITHOUT PRIOR NOTIFICATION TO THE STAKEHOLDERS.
 *SPECIAL LENGTHS CAN BE PROVIDED UPON REQUEST, SUBJECT TO A MINIMUM ORDER QUANTITY REQUIREMENT.
 *KN= KILONEWTON (1KN = 100KGS.)