

BUTTON HEAD CAP SCREW

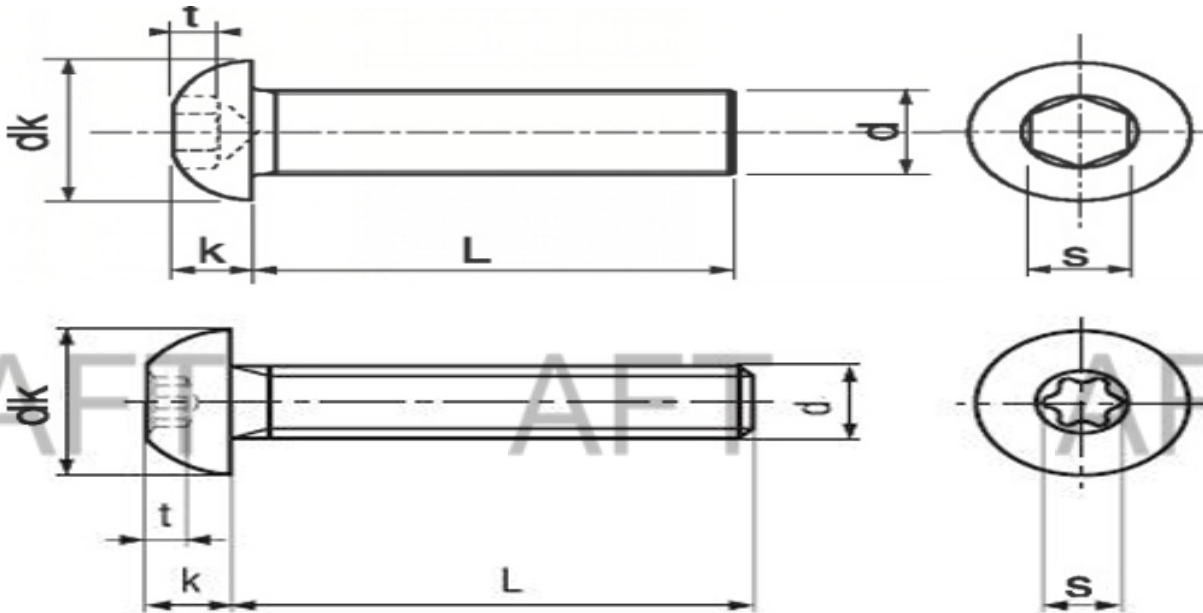

STANDARD	DIN 7380/ ISO 7380
GRADES	A2 , A4



DIAMETER (D)	M5	M6	M8	M10	M12
HEAD DIA (DK)	9.5	10.5	14	17.5	21
HEAD HEIGHT (K)	2.75	3.3	4.4	5.5	6.6
ACROSS FLAT (S)	3	4	5	6	8
SOCKET DEPTH (T) MIN.	1.56	2.08	2.6	3.12	4.16
THREAD PITCH	0.80	1.00	1.25	1.50	1.75
LENGTHS	8-50	10-65	12-130	20-130	25-130

NOTE:

*ALL LOAD TOLERANCES CAN BE ACHIEVED IN ACCORDANCE WITH THE SPECIFIED DIMENSIONS MENTIONED ABOVE.
 *ANY MODIFICATIONS TO THE PRODUCT PORTFOLIO CAN BE IMPLEMENTED WITHOUT PRIOR NOTIFICATION TO THE STAKEHOLDERS.
 *SPECIAL LENGTHS CAN BE PROVIDED UPON REQUEST, SUBJECT TO A MINIMUM ORDER QUANTITY REQUIREMENT.