

**BIOLOGY – I****{ Chap 1 : Reproduction in Lower and Higher Plants }****Time : 1<sup>1/2</sup> Hours****Total Marks : 30****SECTION – A****Q1. Select and write the correct answer :****[04]**

I. A ditheous anther is -----.

- (A) trisporangiate (B) unisporangiate  
 (C) tetrasporangiate (D) bisporangiate

II. Synergids show hair like projections called -----

- (A) funiculus (B) filiform apparatus  
 (C) polar nuclei (D) antipodals

III. If diploid chromosome number in a flowering plant is 12 , then which one of the following will have 6 chromosomes ?

- (A) Cotyledons (B) Endosperm  
 (C) Leaf cells (D) Synergids

IV. Polyembryony is commonly observed in -----

- (A) mango (B) orange  
 (C) lemon (D) all these

**Q2. Answer the following questions :****[04]**

I. Define microsporogenesis.

II. Name the plants which exhibits both chasmogamous and cleistogamous flowers on the same plant.

III. Name the part of gynoecium that determines the compatible nature of pollen grain.

IV. What is an anatropous ovule ?

**SECTION – B****Attempt any Six****[12]**

Q3. Sketch and label angiospermic embryo sac .

Q4. Write any four adaptations of hydrophilous flowers. Mention any one example.

Q5. Write a short note on entomophily.

Q6. Write the significance of seed and fruit.

Q7. How polyembryony can be commercially exploited?

Q8. Define : Apogamy and Apospory.

Q9. Complete the following table :

Type of Pollination	Agent	Example
1. Anemophily	Wind	-----
2. Chiropterophily	-----	Kadamb
3. Ornithophily	-----	-----

Q10. Match the following :

Column I	Column II
1. Egg	a. Testa
2. Nucellus	b. Tegmen
3. Outer Integument	c. Perisperm
4. Inner Integument	d. Embryo

**SECTION – C****Attempt any Two****[06]**

Q11. Explain the categories of apomixis.

Q12. Draw neat and labelled diagram of dicot seed and monocot seed.

Q13. a) Distinguish between : Asexual reproduction and Sexual reproduction

b) Incompatibility is a natural barrier in the fusion of gametes.

How will you explain this statement?

Q14. What are three types of endosperms. Describe any one of them with suitable diagram.

**SECTION – D****Attempt any One :****[04]**

Q15. Explain in detail Pollen-Pistil interaction.

Q16. Describe the process of double fertilization with neat labeled diagram.



**BIOLOGY – II**  
**{ Chap 9 : Control and Coordination }**

**Time : 1<sup>1/2</sup> Hours**

**Total Marks : 30**

**SECTION – A**

**Q1. Select and write the correct answer : [04]**

I. ----- is a neurotransmitter

- (A) ADH                      (B) Acetyl CoA  
 (C) Acetylcholine        (D) Inositol

II. Corpus callosum is a nerve fibre bridge which connects -----

- (A) two cerebral hemispheres        (B) cerebrum and cerebellum  
 (C) cerebellum and medulla            (D) midbrain and hind brain

III. The innermost layer of human eye is -----

- (A) choroid    (B) cornea  
 (C) sclera     (D) retina

IV. Milk secretion in lactating women is controlled by -----

- (A) LH            (B) Prolactin  
 (C) Relaxin     (D) Oestrogen

**Q2. Answer the following questions : [04]**

- I. Define Post-synaptic neuron.  
 II. Which are silent areas of the brain ?  
 III. How does tongue detect the sensation taste ?  
 IV. How is Cushing's disease caused ?

**SECTION – B**

**Attempt any Six [12]**

- Q3. Write a note on psychological disorders.  
 Q4. Distinguish between glucocorticoids and mineralocorticoids  
 Q5. Sketch and label diagram showing 'Formation of Spinal Nerve'.

- Q6. Distinguish between the sympathetic and parasympathetic nervous system .  
 Q7. Injury to the medulla oblongata causes sudden death – Explain.  
 Q8. Write a short note on neuroglia.  
 Q9. Give Functions of Spinal Cord.  
 Q10. Distinguish between Cerebrum and Cerebellum.

**Attempt any Two**

[06]

- Q11. Sketch, label and describe the nervous system in Hydra.  
 Q12. Describe briefly the structure of multipolar neuron with suitable diagram.  
 Q13. State the hormones secreted by hypothalamous and their functions.  
 Q14. Describe morphology of thyroid gland with a suitable diagram.

**SECTION – D**

**Attempt any One :**

[04]

- Q15. Name the two regions of adrenal gland.  
 Explain the regions and the hormones secreted in detail.  
 Q16. Describe the structure shown in the given diagram.

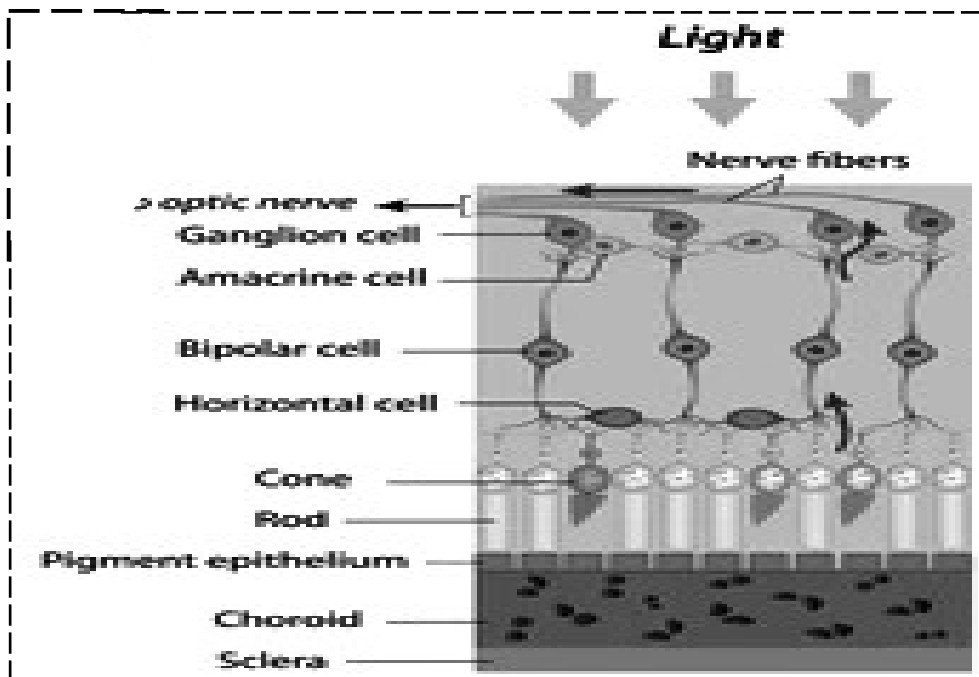

- Q17. Describe the internal structure of human ear.

**MARCH 27**



**CHEMISTRY – I**  
**{ Chap 1 : Solid State }**

---

**Time : 1<sup>1/2</sup> Hours**

**Total Marks : 30**

---

**SECTION – A**

**Q1. Select and write the correct answer :**

**[04]**

I. The number of types of orthorhombic unit cell is -----.

- (A) 7      (B) 3  
(C) 4      (D) 2

II. In crystal lattice formed by bcc unit cell, the void volume is -----

- (A) 68%      (B) 74%  
(C) 32%      (D) 26%

III. Schottky defects are observed in which solid among the following ?

- (A) Silver iodide    (B) Brass  
(C) Zinc sulphide    (D) Silver bromide

IV. Which of the following is an example of diamagnetic substance ?

- (A) CrO<sub>2</sub>      (B) O<sub>2</sub>  
(C) Ni      (D) NaCl

**Q2. Answer the following questions :**

**[04]**

I. Define : Packing efficiency.

II. Give examples of crystalline solids.

III. What are ferromagnetic substances ?

IV. What are the coordination numbers of spheres in three dimensional hcp and ccp lattices ?

**SECTION – B****Attempt any Six****[12]**

- Q3. What do you mean by isomorphism and polymorphism ?
- Q4. Ionic solids conduct electricity in molten state but not in solid state. Give reason.
- Q5. Explain the terms : a) Unit cell b) Point defects
- Q6. How are tetrahedral and octahedral voids formed ?
- Q7. Tungsten crystallizes in bcc unit cell with edge length of 315.5 pm .  
What is the radius of tungsten atom ?
- Q8. What are nonstoichiometric defects ? Give its types.
- Q9. Distinguish between Schottky and Frenkel defects.
- Q10. Explain the origin of magnetic properties in solids.

**SECTION – C****Attempt any Two****[06]**

- Q11. Explain the band theory.
- Q12. What are p-type semiconductors ? Why is the conductivity of doped n – type semiconductor higher than that of pure semiconductor ?  
Explain with diagram
- Q13. Obtain the relationship between density of a substance and the edge length of unit cell.

**SECTION – D****Attempt any One :****[04]**

- Q14. a) Distinguish between crystalline and amorphous solids.  
b) A metal crystallizes into two cubic faces namely face centered (fcc) and body centered (bcc), whose unit cell edge lengths are 4 Å and 3.5 Å respectively . Find the ratio of the densities of fcc and bcc.
- Q15. a) Distinguish between square close packing and hexagonal close packing in two dimensions.  
b) Iron crystallizes in bcc structure with unit cell edge length of 287 pm.  
What is the radius of Fe atoms ? How many unit cells are there in 3.00 cm<sup>3</sup> of Fe.
- Q16. Distinguish between Metal conductor, Insulator, Semiconductor.





**CHEMISTRY – II**  
**{ Chap 10 : Halogen Derivatives }**

**Time : 1<sup>1/2</sup> Hours**

**Total Marks : 30**

**SECTION – A**

**Q1. Select and write the correct answer :**

**[04]**

I. IUPAC name of the following compound is -----.

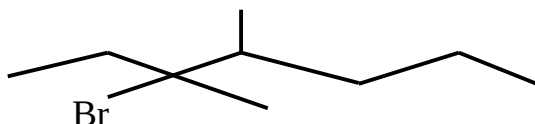

- (A) 3-bromo-3,4-dimethylheptane      (B) 3,4-dimethyl-3-bromoheptane  
 (C) 5-bromo-4,5-dimethylheptane      (D) 4,5-dimethyl-5-bromoheptane

II.  $C_2H_5 - Br + NaI \xrightarrow{\text{dry acetone}} C_2H_5 - I + NaBr$

- (A) Wurtz reaction    (B) Sandmeyer reaction  
 (C) Swarts reaction    (D) Finkelstein reaction

III. The racemic mixture of an optically active compound is -----

- (A) dextrorotatory    (B) laevorotatory    (C) optically inactive    (D) optically active

IV. The stability order for carbocation is -----

- (A)  $2^\circ > 3^\circ > 1^\circ$     (B)  $3^\circ > 2^\circ > 1^\circ$     (C)  $3^\circ > 1^\circ > 2^\circ$     (D)  $1^\circ > 3^\circ > 2^\circ$

**Q2. Answer the following questions :**

**[04]**

I. How boiling point of alkyl halides is determined ?

II. Give examples of allylic halide and Vinylic halide.

III. Mark the chiral carbon atoms in following compounds :

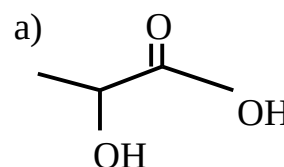
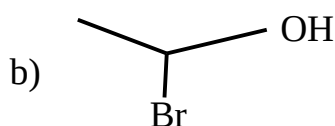

IV. Write structure : 1-Chloro-4-ethyl cyclohexane

## SECTION – B

## Attempt any Six

[12]

Q3. What is ordinary light ? What happens when ordinary light is passed through Nicol's prism ?

Q4. Draw structures of enantiomers of 2-bromobutane using wedge formula.

Q5. Convert the following using appropriate reagent.

a) methyl iodide to methyl acetate

b) 2-chloropropane to 2-methylpropanenitrile

Q6. Give a brief idea about changes that occur in substrate during nucleophilic substitution reactions ( $S_N$ ).

Q7. Which of the following two compounds would react faster by  $S_N2$  mechanism and Why ? a) 1- chlorobutane b) 2-chlorobutane

Q8. Explain : but-2-ene is the preferred product during dehydrohalogenation of 2-bromobutane.

Q9. Write a note on Sandmeyer's reaction.

Q10. How is Grignard Reagent prepared ?

## Attempt any Two

[06]

Q11. Aryl halides show low reactivity towards nucleophilic substitution reactions. Explain with suitable example.

Q12. Explain the following reactions with respect to chlorobenzene.

a) Nitration b) Sulfonation c) Friedel-Craft's reaction

Q13. Write a note on a) Freons b) DDT

Q14. Complete the following reactions by writing the structural formulae of the organic compounds "A" and "B".

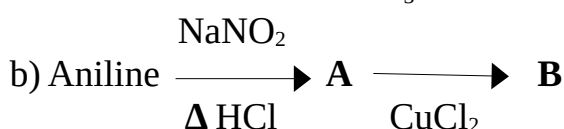
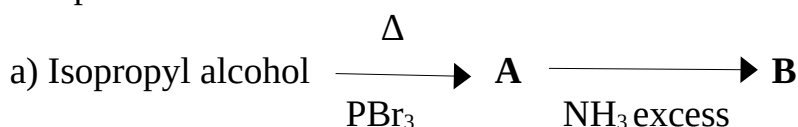

MARCH 27

## SECTION – D

## Attempt any One :

[04]

Q15. a) Explain the method of preparation of alkyl halides using phosphorous halide.

b) Identify the products of the following reactions :

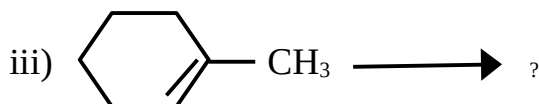
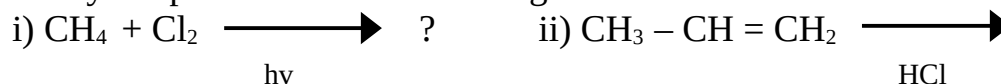

Q16. a) Write a note on halogen exchange reactions.

b) Explain Wurtz – fitting reaction.



**PHYSICS– I**  
**{ Chap 1 : Rotational Dynamics }**

**Time : 1<sup>1/2</sup> Hours**

**Total Marks : 30**

**SECTION – A**

**Q1. Select and write the correct answer :** **[04]**

I. A body of mass 'm' performs uniform circular motion along a circular path of radius 'r' with velocity 'v'. If its angular momentum is 'L', then the centripetal force acting on it is ----- . (A)  $L^2 / mr$  (B)  $L^2 / mr^2$  (C)  $mL^2 / r^3$  (D)  $L^2 / mr^3$

II. Two bodies of mass 10kg and 5 kg are moving in concentric orbits of radius R and r . If their time periods are same, then the ratio of their centripetal acceleration is ----- . (A)  $r/R$  (B)  $R^2/r^2$  (C)  $r^2/R^2$  (D)  $R/r$

III. Rotational K.E. of a body is 10J. If the angular momentum vector coincides with the axis of rotation and its M.I. about this axis is  $5\text{kgm}^2$  then its angular momentum is ----- (A) 10 SI units (B) 40 SI units (C) 30 SI units (D) 20 SI Units

IV. The angular momentum of a wheel changes from 2L to 5L in 3 second . What is the magnitude of the torque acting on it ? (A) L (B)  $L/5$  (C)  $L/2$  (D)  $L/3$

**Q2. Answer the following questions :** **[04]**

I. Define : Uniform Circular Motion

II. What will happen if one raves fast over a speed breaker ? Why ?

III. What is Simple Pendulum.

IV. Define : Moment of Inertia , State its dimensions.

**SECTION – B**

**Attempt any Four** **[12]**

Q3. Distinguish between Uniform Circular Motion and Non-uniform Circular Motion.

Q4. Explain the concept : Centrifugal Force

Q5. Explain why are curved roads banked ?

- Q6. A vehicle is moving on a circular track whose surface is inclined towards the horizon at an angle of  $20^\circ$ . the maximum velocity with which it can move safely is 36 km/hr. Calculate the length of the circular track. ( $\pi = 3.142$ )
- Q7. In a circus, a motor-cyclist having mass of 50kg moves in a spherical cage of radius 3m. Calculate the least velocity with which he must pass the highest point without losing contact. Also calculate his angular speed at the higher point.
- Q8. Starting from the rest, a body rolls down along an incline that rises by 3 in 5 along the plane. The body gains a speed of  $\sqrt{10}$  m/s as it travels a distance of  $\frac{5}{3}$  m along the incline. What can be the possible shape(s) of the body?
- Q9. State the law of conservation of angular momentum and explain it with a suitable example.
- Q10. State and prove the theorem of parallel axis.

## SECTION – C

**Attempt any Two****[06]**

- Q11. Explain interlink between translational, rotational and total kinetic energies of a rigid object that rolls without slipping.
- Q12. Derive an expression for maximum possible speed for a vehicle to move on horizontal unbanked road.
- Q13. Semi-vertical angle of the conical section of a funnel is  $37^\circ$ . There is a small ball kept inside the funnel. On rotating the funnel, the maximum speed that the ball can have in order to remain in the funnel is 2 m/s. Calculate inner radius of the brim of the funnel. Is there any limit upon the frequency of rotation? How much is it? Is it lower or upper limit? Give a logical reasoning. (Use  $g = 10\text{m/s}^2$ , and  $\sin 37^\circ = 0.6$ )
- Q14. A body of mass 200g attached to a string of length 50cm is whirled in a vertical circle by giving it a velocity of 6 m/s at the lowest point. Find the velocity at the highest point ( $g = 10\text{m/s}^2$ )



## SECTION – D

**Attempt any One :****[04]**

- Q15. a) Derive an expression for kinetic energy of a body with a constant angular velocity  
 b) Explain the significance of moment of inertia.
- Q16. a) Derive an expression that relates angular momentum with the angular velocity of a rigid body.  
 b) Thin uniform rod of mass 3kg and 2kg starts from rest and rotates about an axis passing through its centre and perpendicular to its length with a speed 1200 r. p. m for 10 seconds. Find torque acting on it.

MARCH 26



**PHYSICS– II**  
**{ Chap 8 : Electrostatics }**

**Time : 1<sup>1/2</sup> Hours**

**Total Marks : 30**

**SECTION – A**

**Q1. Select and write the correct answer : [04]**

I. The relation between electric charge, electric potential and capacity is -----  
(A)  $C = Q/V$       (B)  $C = V/Q$       (C)  $V = QC$       (D) None of these

II. The permittivity of medium is  $35.4 \times 10^{-12} \text{ C}^2/\text{Nm}^2$ . The dielectric constant of the medium will be -----  
(A) 3      (B) 2      (C) 4      (D) 1

III. Energy stored in a capacitor and dissipated during charging a capacitor bear a ratio -----  
(A) 1:1      (B) 2:1      (C) 1:3      (D) 1:2

IV. In a uniform electric field, a charge of 4 C experiences a force of 4000N. The potential difference between two points 2 cm apart along the electric lines of force will be -----  
(A) 10V      (B) 20V      (C) 4 V      (D) 0.2 V

**Q2. Answer the following questions : [04]**

I. The charge per unit area of a large flat sheet of charge is  $4 \mu\text{C}/\text{m}^2$ . Calculate the electric field intensity at a point just near the surface of the sheet, measured from its midpoint.

II. Define : Electrostatic Potential Energy of a system of potential charges.

III. State the reason : Restricted movements of charge carriers in electrolytic conductors.

IV. Justify : The safest way to protect oneself from lightning is to be inside a car.

**SECTION – B**

**Attempt any Four [12]**

Q3. What is electric susceptibility of dielectric medium. Explain the reduction of electric field inside a polarized dielectric.

- Q4. Capacity of a parallel capacitor with dielectric constant 5 is  $40 \mu\text{F}$ . Calculate the capacity of the same capacitor when dielectric material is removed.
- Q5. Write a note on zero potential.
- Q6. A small particle carrying a negative charge of  $1.6 \times 10^{-19} \text{C}$ . is suspended in equilibrium between two horizontal metal plates  $10\text{cm}$  apart having a potential difference  $3000\text{V}$  across them. Find the mass of the particle.
- Q7. Explain electrostatic shielding with examples.
- Q8. Explain : Energy storing in a capacitor.
- Q9. Explain the concept of displacement current.
- Q10. A parallel -plate air capacitor has a capacity of  $30\mu\text{F}$ . What will be its new capacity if a) the distance between the plates is doubled b) a marble slab of dielectric constant 6 is introduced filling the entire space between the two plates?

### SECTION – C

#### Attempt any Two

[06]

- Q11. A  $7\mu\text{F}$  capacitor is charged by a  $200 \text{V}$  supply. It is then disconnected from the supply and is connected to another uncharged  $3 \mu\text{F}$  capacitor. How much electrostatic energy of the first capacitor is lost in the form of heat and electromagnetic radiation ?
- Q12. Derive an expression for electric field intensity due to uniformly charged spherical shell or hollow sphere.
- Q13. a) One hundred twenty five small liquid drops, each carrying a charge of  $0.5\mu \text{C}$  and each of diameter  $0.1 \text{m}$  form a bigger drop. Calculate the potential at the surface of the bigger drop. b) Why no work is done to move a charge anywhere in the equatorial plane of electric dipole. Explain.
- Q14. Derive an expression for the electric potential energy of an electric dipole in a uniform electric field.

### SECTION – D

#### Attempt any One :

[04]

- Q15. Describe construction and working of a Van de Graaff generator.
- Q16. a) What is mean by equipotential surface ? Explain its properties.  
b) Derive an expression for the effective or equivalent capacitance of a combination of a number of capacitors connected in parallel.
- Q17. Obtain an expression for the electric potential energy of a configuration of  $N$  point charges.





**MATHEMATICS– I**  
**{ Chap 1 : Mathematical Logic }**

**Time : 1<sup>1/2</sup> Hours**

**Total Marks : 30**

**SECTION – A**

**Q1. Select and write the correct answer :** **[04]**

I. The logically equivalent statement of  $\sim p \vee \sim q$  is -----.

- (A)  $p \wedge q$       (B)  $\sim p \wedge \sim q$       (C)  $\sim(p \wedge q)$       (D)  $\sim(p \vee q)$

II. Negation of  $\sim(p \vee q)$  is -----.

- (A)  $p \wedge \sim q$       (B)  $\sim p \wedge \sim q$       (C)  $p \vee \sim q$       (D)  $\sim p \vee \sim q$

**Q2. Answer the following questions :** **[04]**

I. Write Truth values of the following : If  $3 \times 4 = 7$  then  $3 + 4 = 12$  .

II. Write the negations of the following :  $11 < 15$  and  $25 > 20$

III. Rewrite the following statements without using If ---- then : If 2 is a rational number then  $\sqrt{2}$  is irrational number .

IV. What is the converse of the contrapositive of  $\sim p \rightarrow q$

**SECTION – B**

**Attempt any Six** **[12]**

Q3. Express the given circuit in the symbolic form of logic and write the input-output table.

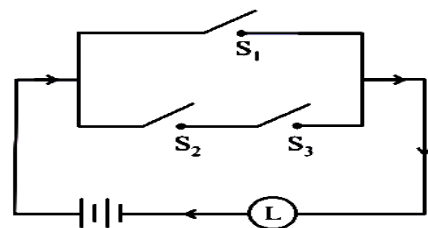

Q4. Prepare the truth table of  $(p \wedge q) \rightarrow (\sim p)$

Q5. Using rules in logic, prove the following :  $\sim(p \vee q) \vee \sim(p \wedge q) = \sim p$

Q6. Using the rules in logic , write the negations of given case :  $(p \rightarrow q) \wedge r$

Q7. Write the truth values of the given statement :  $\sqrt{5}$  is an irrational but  $3\sqrt{5}$  is a complex number.

Q8. Determine whether the given statement pattern is tautologies contradictions or contingencies :  $(p \rightarrow q) \wedge (p \wedge \sim q)$

Q9. Examine whether given statement pattern is a tautology, contradiction or contingency :  $(p \rightarrow q) \leftrightarrow (\sim p \vee q)$

**Ans:**

p	q	$\sim p$	$p \rightarrow q$	$\sim p \vee q$	$(p \rightarrow q) \leftrightarrow (\sim p \vee q)$
T	T	F	T	T	T
T	F	F	F	F	T
F	T	T	T	T	T
F	F	T	T	T	T

Q10. Obtain simple logical expression of  $(\sim p \wedge q) \vee (\sim p \wedge \sim q) \vee (p \wedge \sim q)$ . Draw a switching circuit.

**SECTION – C**

**Attempt any Two**

**[06]**

Q11. Simply the following so that the new circuit has minimum number of switch. Draw the simplified circuit.

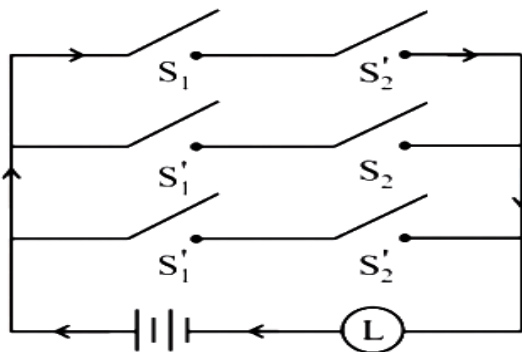

Q12. Construct the switching circuit of the following :  $(p \wedge q) \vee (\sim p) \vee (p \wedge \sim q)$

Q13. Obtain the simple logical expression and draw the corresponding switching circuit  $[p \vee (\sim q \vee \sim r)] \wedge [p \vee (q \wedge r)]$

Q14. Using truth table , prove logical equivalence :  $(p \wedge q) \rightarrow r \equiv p \rightarrow (q \rightarrow r)$ .

SECTION – D

Attempt any One :

[04]

Q15. Simplify the following so that the new circuit has minimum switches.

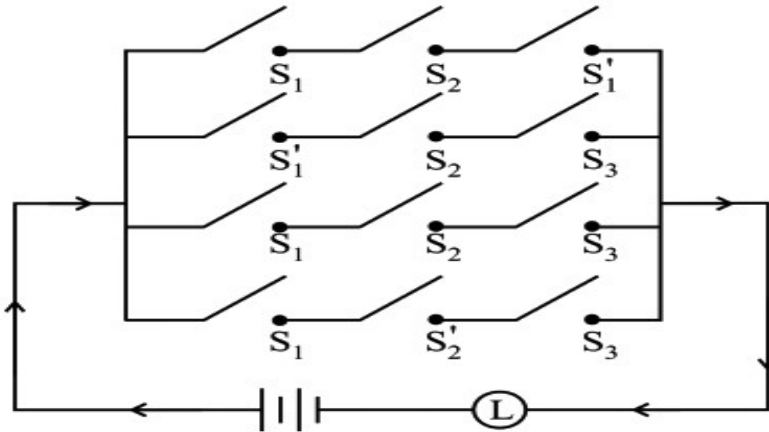

Q16. a) Construct the switching circuit of the following :

$$[(p \wedge r) \vee (\sim q \wedge \sim r)] \wedge (\sim p \wedge \sim r)$$

b) Write symbolic form ,switching table and interpretation for the following circuit

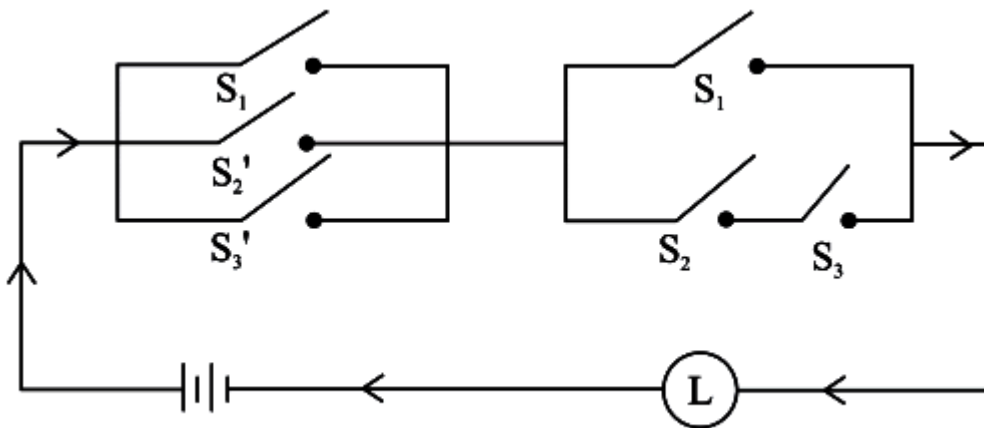

MARCH 27





**MATHEMATICS– II**  
**{ Chap 1 : Differentiation }**

**Time : 1<sup>1/2</sup> Hours**

**Total Marks : 25**

**SECTION – A**

**Q1. Select and write the correct answer :** **[04]**

I. If  $y = \log (\tan x^\circ + \sec x^\circ)$ , then  $dy/dx$  is -----.

(A)  $\sec x^\circ$     (B)  $1/\sec x^\circ$     (C)  $180 / \pi \sec x^\circ$     (D)  $\frac{\pi}{180} \sec x^\circ$

II. If  $y = \sec (\tan^{-1} x)$  then  $dy/dx$  at  $x = 1$ , is equal to : -----.

(A)  $1/2$     (B)  $1$     (C)  $1/\sqrt{2}$     (D)  $\sqrt{2}$

**Q2. Answer the following questions :** **[03]**

I. If  $f(x) = \frac{x^2 - a^2}{x^2 + a^2}$  and  $f'(1) = 1$ , then find  $a$ .

II. Find the derivative of the inverse function of :  $y = x \log x$

III. Differentiate  $\sin(x^2 + x)$  w.r.t  $x$

IV. Differentiate  $\tan^{-1} (2x / 1 - x^2)$

**SECTION – B**

**Attempt any Four** **[08]**

Q3. Differentiate w.r.t  $x$  :  $\cos(x^2 + a^2)$

Q4. If  $y = \tan^{-1} x$ ,  $x \in \mathbb{R}$ ,  $-\pi/2 < y < \pi/2$ , then  $dy/dx = 1 / 1 + x^2$

Q5. Find the derivative of the function  $y = f(x)$  using the derivative of the inverse function  $x = f^{-1}(y)$  :  $y = \sqrt{x}$

Q6. Differentiate the following w.r.t  $x$  :  $\tan^{-1}(\log x)$

Q7. Find  $dy/dx$ , If  $x\sqrt{x} + y\sqrt{y} + a\sqrt{a}$

Q8. If  $e^x + e^y = e^{x+y}$ , then show that  $\frac{dy}{dx} = -e^{y-x}$ .

Q9. Differentiate w.r.t.  $x$  :  $\sqrt{\cos x} + \sqrt{\cos\sqrt{x}}$

Q10. Using derivative, prove that :  $\tan^{-1} x + \cot^{-1} x = \pi/2$

**Attempt any Two**

**[06]**

Q11. Differentiate  $x^x$  w.r.t  $x^{\sin x}$

Q12. If  $2y = \sqrt{x+1} + \sqrt{x-1}$ , show that  $4(x^2-1)y_2 + 4xy_1 - y = 0$ .

Q13. Find the  $n^{\text{th}}$  derivative of the following :  $(ax + b)^m$

Q14. Show that  $\frac{dy}{dx} = y/x$  in the following, where  $a$  and  $p$  are constants :

$$x^7 \cdot x^5 = (x+y)^{12}$$

**SECTION – D**

**Attempt any One :**

**[04]**

Q15. Differentiate the following w.r.t.  $x$  :  $\tan^{-1}(\operatorname{cosec} x + \cot x)$

Q16. Differentiate the following w.r.t  $x$  :  $(\sin x)^{\tan x} + (\cos x)^{\cot x}$



**MARCH 27**