

STUDENT **ASTRONAUT** CHALLENGE

ORBITER VEHICLE TECHNICAL MANUAL

Ver. 240723.01

Questions regarding the organization and content of the Vehicle Technical Manual should be directed to one of the following SAC representatives:

Matt Porter

Simulations Operator (Sim-Op)

olorin1010@yahoo.com

Tim Wolff

Flight Director (FD)

astronautchallenge@gmail.com

Some information in this manual was gathered from the National Aeronautics and Space Administration documentation. This document does not supersede any other document. It is solely for use in the Student Astronaut Challenge Competition.

TABLE OF CONTENTS

PREFACE	VI
1 GENERAL OVERVIEW	1
1.1 VEHICLE STRUCTURE	1
1.2 NOMINAL MISSION PROFILE	2
1.2.1 Launch	2
1.2.2 Orbit	2
1.2.3 De-Orbit	3
1.2.4 Landing	3
1.3 LAUNCH AND LANDING SITES	3
SYSTEMS	5
2 AUXILIARY POWER UNIT/ HYDRAULICS (APU/HYD)	5
2.1 INTRODUCTION	5
2.2 APU COMPONENTS	6
2.2.1 Fuel System	6
2.2.2 Gas Generator and Turbine	8
2.2.3 Lubricating Oil	8
2.2.4 Electronic Controller	8
2.2.5 Water Spray Boilers	8
2.3 HYDRAULIC COMPONENTS	9
2.3.1 Main Hydraulic Pump:	9
2.3.2 Circulation Pump:	10
2.3.3 Hydraulic Accumulator:	10
2.4 APU/HYD MISSION DETAILS	10
2.5 APU/HYD CAUTION AND WARNING SYSTEM	10
APU/HYD SUMMARY	12
3 CAUTION AND WARNING SYSTEM (C/W)	13
3.1 INTRODUCTION	13
3.2 C/W OPERATIONS	13
3.2.1 Caution (Yellow):	14
3.2.2 Alarm (Red):	14
ANNUNCIATOR PANEL WARNING DIRECTORY	14
C/W SUMMARY	16
4 COMMUNICATIONS	17
4.1 INTRODUCTION	17
4.2 COMMUNICATIONS OPERATIONS	17
4.2.1 S-Band Phase Modulation	17
4.2.2 S-Band Frequency Modulation	18
4.2.3 Ku-Band System:	19
4.2.4 Ultrahigh Frequency System	20
COMMUNICATIONS SUMMARY	21
5 DATA PROCESSING SYSTEM (DPS)	22
5.1 INTRODUCTION	22
5.2 GENERAL PURPOSE COMPUTERS (GPCs)	23
5.3 DATA BUS NETWORK	25

5.4 THE KEYBOARD (MACRO PAD) GPC INTERFACE	26
5.5 DATA PROCESSING CAUTION AND WARNING SYSTEM.....	27
DPS SUMMARY	29
6 ELECTRICAL POWER SYSTEM	30
6.1 INTRODUCTION	30
6.2 POWER REACTANTS STORAGE AND DISTRIBUTION SYSTEM.....	30
6.3 FUEL CELL SYSTEM	32
6.4 ELECTRICAL POWER DISTRIBUTION AND CONTROL (EPDC).....	33
6.4.1 DC Power System	35
6.4.2 AC Power System	36
6.5 EPS OPERATIONS.....	38
6.6 EPS CAUTION AND WARNING SYSTEM.....	38
EPS SUMMARY	40
7 ENVIRONMENTAL CONTROL AND LIFE SUPPORT SYSTEM (ECLSS)	41
7.1 INTRODUCTION.....	41
7.2 PRESSURE CONTROL SYSTEM (PCS).....	42
7.3 ATMOSPHERIC REVITALIZATION SYSTEM (ARS)	42
7.4 ACTIVE THERMAL CONTROL SYSTEM (ATCS).....	42
7.5 SUPPLY AND WASTEWATER SYSTEMS	43
7.6 ECLSS OPERATIONS	43
7.7 ECLSS CAUTION AND WARNING SYSTEM	45
ECLSS SUMMARY	46
8 GUIDANCE, NAVIGATION, AND CONTROL (GNC)	47
8.1 INTRODUCTION.....	47
8.2 GNC COMPONENTS	47
8.2.1 Inertial Measurement Units	47
8.2.2 Star Trackers	48
8.2.3 Global Positioning System:	49
8.2.4 Flight Control System Hardware.....	50
8.3 GNC OPERATIONS	51
8.4 GNC CAUTION AND WARNING SYSTEM	52
GNC SUMMARY	53
9 MAIN PROPULSION SYSTEM (MPS)	54
9.1 INTRODUCTION.....	54
9.2 MPS COMPONENTS	54
9.2.1 Space Shuttle Main Engine	54
9.2.2 SSME Components: The SSME major components are the fuel and oxidizer turbopumps, preburners, a hot gas manifold, main combustion chamber, nozzle, oxidizer heat exchanger, and propellant valves.....	56
9.2.3 Propellant Management System (PMS)	57
9.2.4 Hydraulic System	57
9.3 MPS OPERATIONS	57
9.4 MPS CAUTION AND WARNING.....	60
MPS SUMMARY	61
10 MECHANICAL SYSTEMS.....	62
10.1 INTRODUCTION.....	62
10.2 MECHANICAL SYSTEMS COMPONENTS	62
10.2.1 Active Vent System	62
10.2.2 External Tank Umbilical Doors.....	62

10.2.3 Payload Bay Door System	62
10.2.4 Landing and Deceleration System	63
10.2.5 Radiators	63
10.2.6 Ku-Band Antenna:.....	63
MECHANICAL SYSTEMS SUMMARY	64
11 ORBITAL MANEUVERING SYSTEM (OMS).....	65
11.1 INTRODUCTION.....	65
11.2 OMS COMPONENTS	65
11.2.1 OMS Engines.....	65
11.2.2 Nitrogen System	67
11.2.3 Helium System	67
11.2.4 Propellant Storage and Distribution.....	68
11.2.5 Thrust Vector Control (TVC).....	68
11.3 OMS OPERATIONS:.....	68
11.4 OMS MISSION DETAILS:	69
11.5 OMS CAUTION AND WARNING SYSTEM	70
OMS SUMMARY	71
12 REACTION CONTROL SYSTEM (RCS).....	72
12.1 INTRODUCTION.....	72
12.2 RCS COMPONENTS	72
12.2.1 RCS Thrusters.....	72
12.2.2 RCS Jets.....	72
12.2.3 RCS Fuel/Oxidizer.....	73
12.3 RCS OPERATIONS	74
12.3.1 Tank isolation valves.....	74
12.3.2 Leg and Manifold Isolation Valves.....	74
12.3.3 Crossfeed System.....	75
12.4 RCS MISSION DETAILS	75
12.5 RCS CAUTION AND WARNING SYSTEM	77
RCS SUMMARY	78
13 WASTE MANAGEMENT SYSTEM (WMS).....	79
13.1 INTRODUCTION.....	79
13.2 WMS OPERATIONS.....	80
FLIGHT DATA FILES.....	82
14 MISSION CHECKLIST.....	82
14.1 INTRODUCTION.....	82
PRE-LAUNCH CHECKLIST.....	83
ASCENT CHECKLIST.....	87
ORBIT INSERTION CHECKLIST (POST MECO).....	88
DE-ORBIT CHECKLIST.....	92
LANDING CHECKLIST	95
15 SWITCH PANEL DIAGRAMS	96
15.1 INTRODUCTION.....	96
SWITCH PANEL AND DATA SCREENS LAYOUT.....	97
ORBITER COCKPIT PANEL 1	98
ORBITER COCKPIT PANEL 2	99
ORBITER COCKPIT PANEL 3	100

ORBITER COCKPIT PANEL 4	101
ORBITER COCKPIT PANEL 5	102
ORBITER COCKPIT PANEL 6	103
FLIGHT ENGINEER PANEL 7	104
FLIGHT ENGINEER PANEL 8	105
FLIGHT ENGINEER PANEL 9	106
16 EMERGENCY CHECKLISTS	107
16.1 INTRODUCTION	107
16.2 EMERGENCY CHECKLIST OPERATIONS	107
EMERGENCY PROCEDURES DIRECTORY	108
17 VEHICLE SCHEMATICS	121
SYSTEM SCHEMATIC DIRECTORY	121
GENERAL OVERVIEW	123
AUXILIARY POWER UNIT/HYDRAULICS (APU/HYD)	124
COMMUNICATIONS	125
DATA PROCESSING SYSTEM (DPS)	126
ELECTRICAL POWER SYSTEM (EPS)	128
ENVIRONMENTAL CONTROL AND LIFE SUPPORT SYSTEM (ECLSS)	132
GUIDANCE, NAVIGATION, AND CONTROL (GNC)	133
MAIN PROPULSION SYSTEM (MPS)	134
ORBITAL MANEUVERING SYSTEM (OMS)	136
REACTION CONTROL SYSTEM (RCS)	140
APPENDIX A – GLOSSARY/ABBREVIATIONS	144
APPENDIX B - SPACE FLIGHT AND VEHICLE HISTORY	163

PREFACE

The Student Astronaut Challenge (SAC) Vehicle Technical Manual (VTM) is a unique document containing information about all orbiter flight systems and every phase of a generic orbiter mission.

The VTM is a reference document for student astronaut crewmembers. The complexity of the orbiter systems and the unique operational environment, coupled with the numerous malfunction/emergency procedures, necessitates some departures from other space flight manuals. Nonetheless, the VTM is the only single source document, written specifically for student astronauts, with comprehensive data about orbiter systems and operations.

This document contains condensed information from a large number of orbiter vehicle publications. It has been carefully reviewed by the SAC operations team to ensure accuracy of information. In all cases, should a conflict arise between the VTM and any other publication, the data found in the VTM will govern during the SAC competition. If errors are found, please contact the Student Astronaut Challenge team at astronautchallenge@gmail.com

1 GENERAL OVERVIEW

1.1 Vehicle Structure

The orbiter space flight system consists of four primary elements: an orbiter spacecraft, two solid rocket boosters (SRBs), an external tank (ET) to house fuel and oxidizer, and three space shuttle main engines (SSMEs). The vehicle can transport payloads into near Earth orbit 100 to 312 Nautical Miles (nm) above the Earth. Payloads are carried in a bay 15 feet in diameter and 60 feet long. Major system requirements are that the orbiter and the two SRBs be reusable. The orbiter carries a flight crew of up to seven persons (The SAC flight simulator can hold a crew of up to four persons with a mission control team of three.). Missions aboard the orbiter can last up to two weeks (The nominal mission aboard the SAC sim is 45 minutes to 1 hour.). The crew compartment has a shirtsleeve environment, and the acceleration load is never greater than 3 g's. In its return to Earth, the orbiter has a cross range maneuvering capability of about 1,100 nm.

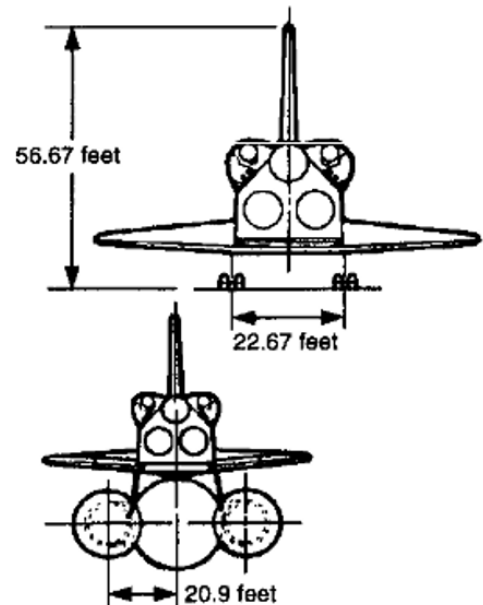
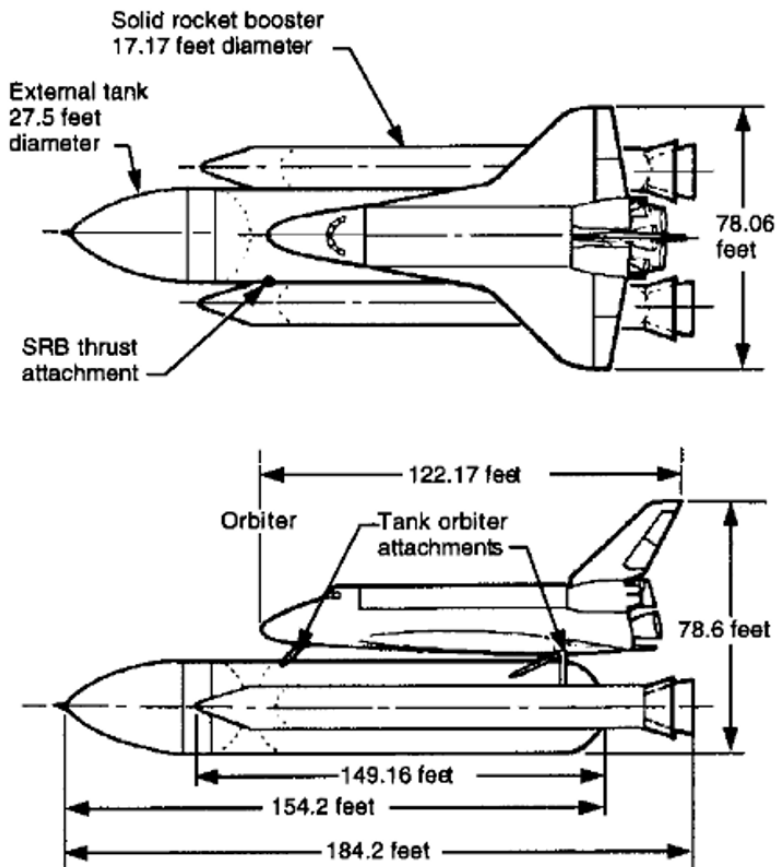

1.2 Nominal Mission Profile

1.2.1 Launch: In the launch configuration, the orbiter and two SRBs are attached to the ET in a vertical (nose up) position on the launch pad. Each SRB is attached at its aft skirt to the mobile launcher platform by four bolts. The three SSMEs, fed liquid hydrogen fuel and liquid oxygen oxidizer from the ET, are ignited first. When it has been verified that the engines are operating at the proper thrust level, a signal is sent to ignite the SRBs. At the proper thrust to weight ratio, initiators (small explosives) at eight hold-down bolts on the SRBs are fired to release the space shuttle for lift-off. The elapsed time is a few seconds.

Maximum dynamic pressure (Max Q) is reached early in the ascent, nominally 44 to 65 seconds after liftoff. During Max Q, the vehicle is throttled down to 67% to minimize forces on the vehicle. After Max Q, the vehicle is throttled up to 104%. Approximately 2 minutes and 5 seconds into the ascent phase, the two SRBs have consumed their propellant and are jettisoned from the ET. This is triggered by a separation signal from the orbiter.

The boosters briefly continue to ascend, while small thrusters fire to carry them away from the space shuttle. The boosters then turn and descend, and at a predetermined altitude, parachutes are deployed to decelerate them for a safe splashdown in the ocean. Splashdown occurs approximately 141 nm from the launch site. The boosters are recovered, refurbished, and reused.

The orbiter and ET continue to ascend, using the thrust of the three SSMEs. Approximately 8 minutes and 55 seconds after launch, the three engines undergo main engine cutoff (MECO), and the ET is jettisoned on command from the orbiter.

1.2.2 Orbit: The forward and aft reaction control system (RCS) jets provide attitude control, translate the orbiter away from the ET at separation, and maneuver the orbiter to burn attitude prior to the orbital maneuvering system (OMS) burn. The ET continues on a ballistic trajectory and enters the atmosphere, where it disintegrates. Its nominal impact is in the Indian Ocean for a 28° inclination launch.

The normal ascent profile, referred to as “direct insertion,” places the vehicle in a temporary elliptical orbit at MECO. Orbital altitudes can vary, depending on mission requirements. The crew then performs an OMS burn, designated as “OMS 1”, to stabilize the orbit. This burn can add anywhere between 200 to 550 feet per second (fps) to the vehicle’s orbital velocity, as necessary.

On orbit, the forward and aft RCS jets provide attitude control of the orbiter, as well as any minor translation maneuvers along a given axis. The OMS engines are used to perform orbital transfers. After completion of the OMS 1 burn, the orbiter is manually moved into a prograde position and the payload bay doors are opened to cool the vehicle. The orbiter is now configured for a mission.

1.2.3 De-Orbit: At the completion of orbital operations, the RCS is used to automatically orient the orbiter in a retrograde (tail-first) attitude. The two OMS engines are burned to lower the orbit such that the vehicle enters the atmosphere at a specific altitude and range from the landing site.

The deorbit burn usually decreases the vehicle's orbital velocity anywhere from 200 to 550 fps, depending on orbital altitude. When the deorbit burn is complete, the RCS is used to automatically rotate the orbiter's nose forward for entry. The RCS jets are used for attitude control until atmospheric density is sufficient for the pitch, roll, and yaw aerodynamic control surfaces to become effective. During the reentry phase, entry guidance must dissipate the tremendous amount of energy the orbiter possesses when it enters the Earth's atmosphere to assure that the orbiter does not either burn up (entry angle too steep) or skip out of the atmosphere (entry angle too shallow). It must also properly position the vehicle to reach the desired touchdown point. (Note: This phase of the mission is skipped during SAC competition to shorten the length of the overall mission.)

1.2.4 Landing: The landing preparation phase begins at approximately 40 km altitude. RCS jet activity is deactivated, leaving only the aerosurfaces to maneuver the vehicle. Atmospheric drag and thus velocity is controlled by adjusting the bank angle and angle of attack. The orbiter is adjusted to an approximately -20° glide slope and is aligned with the runway using instrument and visual identification. This is assisted by the precision approach path indicator (PAPI) lights located at the front of the runway. At approximately 10 km altitude, the final approach phase begins. The flight crew deploys the landing gear at 2.5 km. The speed brake is modulated to hold the reference velocity. The vehicle is flared just before touchdown and the drag chute is deployed at touch down. Wheel brakes are applied to bring the orbiter to a final stop. (For more information on landing, see the Landing Information document on the SAC website)

1.3 Launch and Landing Sites

The Kennedy Space Center (KSC) in Florida is used for all shuttle launches. Shuttle landings occur at KSC as well as at Edwards Air Force Base in California. Contingency landing sites are also provided in the event the orbiter must return to Earth in an emergency.

A 035° azimuth launch places the spacecraft in an orbital inclination of 57°, which means the spacecraft in its orbital trajectories around Earth will never exceed an Earth latitude higher or lower than 57° north or south of the equator. A launch path from KSC at an azimuth of 090° (due east from KSC) will place the spacecraft in an orbital inclination of 28.5°. These two azimuths, 035° and 090°, represent the current launch limits from KSC. Any azimuth angles further north or south would launch a spacecraft over a habitable land mass, adversely affect safety provisions for abort or vehicle separation conditions or present the undesirable possibility that the SRB or external tank could land on inhabited territory.

The Earth rotates from west to east at a speed of approximately 900 nautical miles (nm) per hour. For due east launches (090° azimuth), the Earth's rotational velocity adds to the velocity increase caused by the SRBs and main engines. Due east launches provide the maximum payload and altitude capability. Launches on azimuths other than due east benefit less and less from Earth's rotation as the launch azimuth approaches north or south. Westerly launches would decrease performance even further.

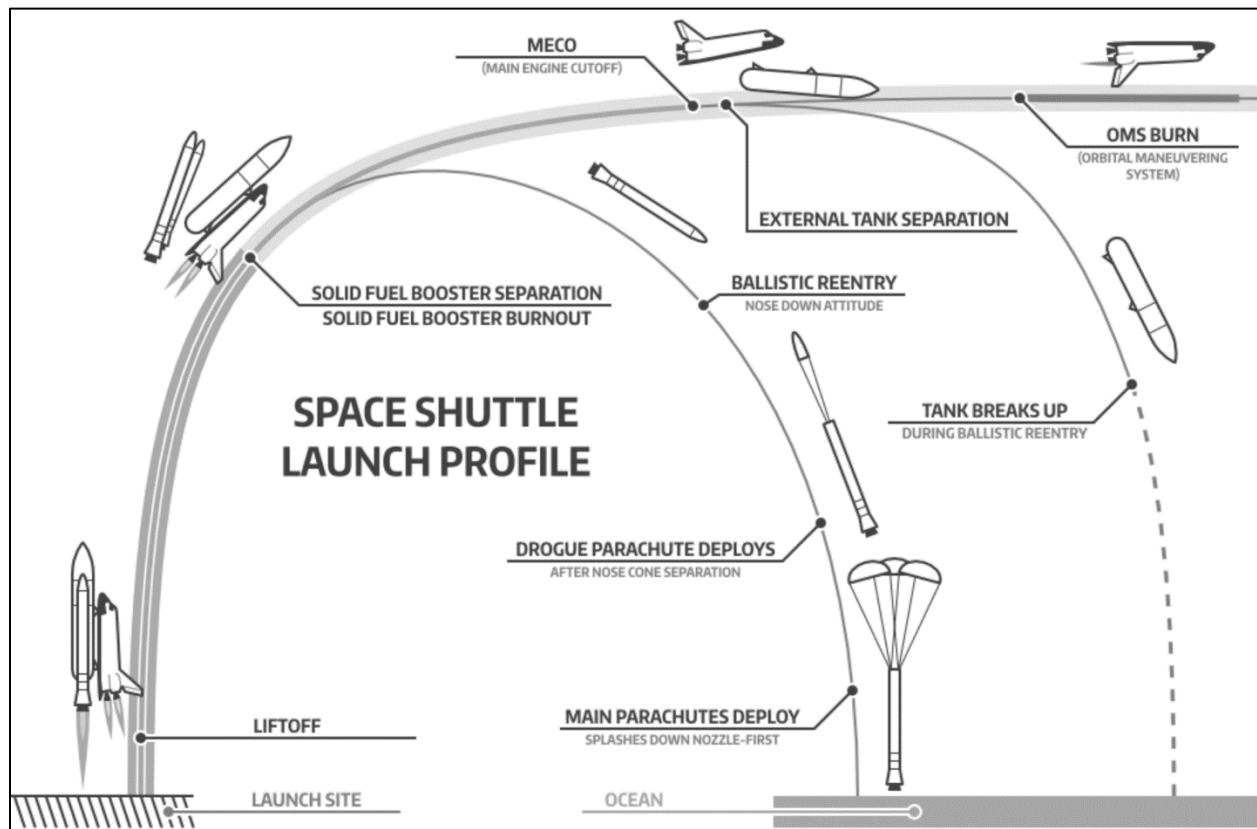

SYSTEMS

This section discusses in detail each of the orbiter systems as listed in the Table of Contents. The subsections are organized alphabetically.

System subsections generally begin with descriptive information covering general purpose, function, and location. Relevant elements of each system are then provided in some detail. Where needed, an illustration of such elements appears as near the reference as possible. In the case of large schematics, appropriate fragments are placed in the text, with full panel diagrams provided in the Appendix.

Most system subsections conclude with a summary. Caution and warning summaries and rules of thumb are also provided where appropriate.

2 AUXILIARY POWER UNIT/ HYDRAULICS (APU/HYD)

2.1 Introduction

The orbiter has three independent hydraulic systems. Each consists of a main hydraulic pump, hydraulic reservoir, accumulator, control valves, Freon heat exchanger, electrical circulation pump, and electrical heaters.

Each system provides hydraulic pressure to position actuators for:

- Thrust vector control (TVC) of the main engines by gimbaling the three SSMEs
- Actuation of various control valves on the SSMEs
- Movement of the orbiter aerosurfaces (elevons, body flap, rudder/speed brake)
- Retraction of the external tank/orbiter 17-inch liquid oxygen and liquid hydrogen disconnect umbilicals with-in the orbiter at external tank jettison
- Main/nose landing gear deployment
- Main landing gear brakes
- Nose wheel steering

Each hydraulic system is capable of operation when exposed to forces or conditions caused by acceleration, deceleration, normal gravity, zero gravity, hard vacuum, and temperatures encountered during on-orbit dormant conditions.

Three identical, but independent, auxiliary power units (APUs) provide power for the orbiter hydraulic systems. The APU is a hydrazine-fueled, turbine-driven power unit that generates mechanical shaft

power to drive a hydraulic pump that produces pressure for the orbiter's hydraulic system. Each unit weighs about 88 pounds and produces 135 horsepower.

Each APU consists of a fuel tank, a fuel feed system, a system controller, an exhaust duct, lube oil cooling system, and fuel/lube oil vents and drains. Each APU fuel system supplies storable liquid hydrazine fuel to its respective fuel pump, gas generator valve module, and gas generator bed, which decomposes the fuel through catalytic action. The resultant hot gas drives a single-stage, dual pass turbine. The turbine assembly provides mechanical power through a shaft to drive reduction gears in a gearbox. The gearbox drives a fuel pump, a hydraulic pump, and a lube oil pump. The hydraulic pump supplies pressure to the hydraulic system.

Three water spray boilers (WSBs), one for each APU, cool the lube oil systems. The hydraulic fluid of each hydraulic pump driven by an APU is also circulated through a hydraulic heat exchanger in the corresponding water spray boiler to cool the fluid during hydraulic system operation.

2.2 APU Components

The Auxiliary Power Unit System consists of multiple components that work together to provide power to the hydraulic system. These components include:

2.2.1 Fuel System: The APU fuel system (one for each of the three APUs) includes the fuel tank, isolation valves, fuel pump, and fuel control valves.

- **Fuel Tanks:** The APU fuel tanks are 28 inch spheres mounted in the aft fuselage. The fuel is storable liquid anhydrous hydrazine. The fuel tank has a total capacity of 350 pounds (Typical launches are loaded with approximately 332 pounds). Under high operating load conditions, an APU consumes approximately 3 to 3.5 pounds of fuel per minute. Each fuel tank's temperature and pressure are monitored by the APU controller and transmitted to the GPC, where the fuel quantity is calculated. Fuel quantity (FUEL QTY) is displayed in System Summary 3.
- **Fuel Tank Isolation Valves:** Tank isolation valves in each APU fuel distribution system are electrically powered solenoid valves that are controlled by the corresponding APU FUEL TNK VLV 1, 2, 3 switches on panel 5.
- **Fuel Pump:** Each APU fuel pump is a fixed-displacement, gear-type pump that discharges fuel at approximately 1,400 to 1,500 psi and operates at approximately 3,918 rpm. Each fuel pump is driven by the turbine through the reduction gearbox. The fuel pump reduction gear is located in the lube oil system gearbox, and a shaft from the reduction gear drives the fuel pump. If leakage occurs through the gear seals, it is directed to a drain line that runs to a 500-cubic centimeter catch bottle for each APU. If the catch bottle is overfilled, it will relieve overboard at approximately 45 psia. This can be monitored on System Summary 1 under (PUMP LEAK P)
- **Fuel Control Valves:** The APU's operating speed is controlled by the fuel control valves, which are installed in series downstream of the fuel pump. These valves are controlled by the APU SPEED SELECT 1, 2, 3 switches on panel 1. The crew can see APU speed listed on the System Summary 3 display (APU SPEED %) in percentage. (100 percent = 72,000 rpm). For safety reasons, each APU has

an automatic shutdown feature that will shut the APU down if the speed falls below 80 percent (57,600 rpm) or rises above 129 percent (92,880 rpm).

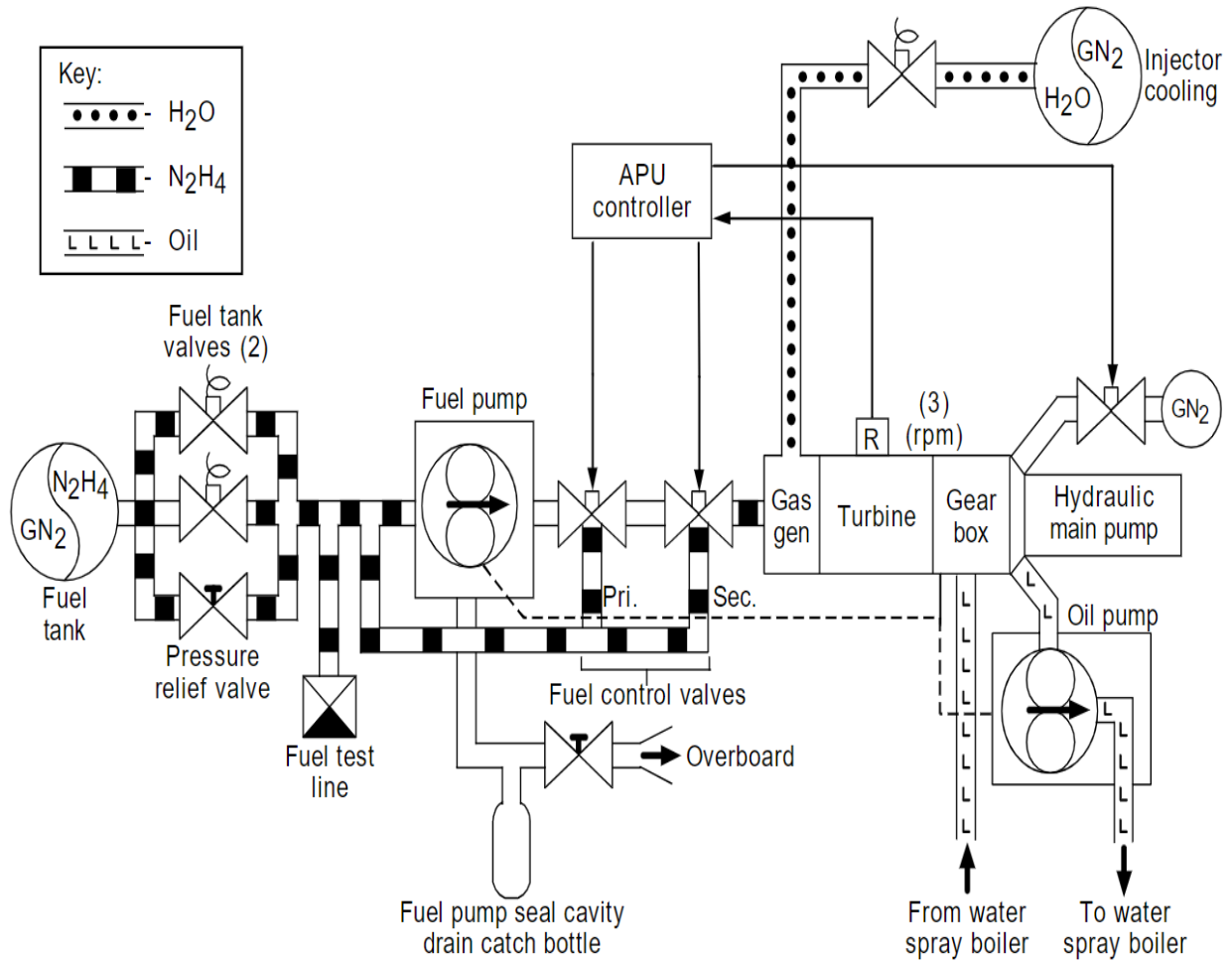

APU FUEL SYSTEM SCHEMATIC

2.2.2 Gas Generator and Turbine: Each gas generator consists of a bed of Shell 405 catalyst in a pressure chamber, mounted inside the APU exhaust chamber. When the hydrazine fuel comes into contact with the catalyst, it undergoes an exothermic reaction, decomposing into a hot gas. The gas expands rapidly and passes through a single-stage turbine wheel and exits overboard through its own independent exhaust duct. The shaft power from the spinning turbine is sent to the hydraulic main pump. It is also used to drive the APU's fuel pump and lubrication oil pump. The temperatures of the gas generator bed, the gas generator supply line, as well as the injector pressure can be found on System Summary 3.

2.2.3 Lubricating Oil: Each APU turbine, through its gearbox, drives a lube oil pump at 12,215 rpm. The following information is transmitted to the System Summary 3 display by the APU controller via the GPC: lube oil pump outlet pressure (OIL OUT P) at approximately 25 psia, outlet temperature at approximately 270° F, and a return temperature from the water spray boiler at approximately 250° F (OIL IN, OUT) for each APU.

2.2.4 Electronic Controller: Each APU has its own digital controller. The controller detects malfunctions, controls turbine speed, gearbox pressurization, and fuel pump/gas generator heaters. Each controller is controlled by the corresponding APU CNTRL POWER 1, 2, 3 switches on panel 5. When the switch is positioned to ON, 28-volt DC power is sent to that controller and APU. When the switch is positioned to OFF, electrical power is removed from that controller and APU.

2.2.5 Water Spray Boilers: The water spray boiler (WSB) system consists of three identical independent water spray boilers, one for each APU/hydraulic system. The boilers are located in the aft fuselage of the orbiter. Each WSB cools the corresponding APU lube oil system and hydraulic system by spraying water onto their lines; as the water boils off, the lube oil and hydraulic fluid are cooled.

The crew can see the WSB water quantity (H2O QTY), nitrogen tank pressure (N2 PRESS), nitrogen regulator pressure (REG PRESS), and nitrogen tank temperature (N2 TEMP) on the right side of System Summary 3.

- **Nitrogen Supply:** The gaseous nitrogen pressure for each WSB is contained in a corresponding 6-inch spherical pressure vessel. The pressure vessel contains 0.77 pound of nitrogen at a nominal pressure of 2,400-2550 psi at 70° F. Each nitrogen valve is controlled by its respective BOILER N2 SUPPLY 1, 2, 3 switch on panel 5.
- **Water Supply:** The water supply for each boiler is stored in a positive-displacement aluminum tank containing a welded metal bellows separating the stored water inside the bellows from the nitrogen expulsion gas. The computer computes the water tank quantity from the pressure, volume, and temperature, and transmits the water tank quantity to the display for each boiler.
- **Temperature Control:** The boiler controller temperatures are maintained by the respective BOILER CNTRL HEATER 1, 2, and 3 switches on panel 5. After the boiler power is turned on using BOILER CNTRL POWER 1, 2, 3 switches (providing the automatic control functions for the

boilers) the boiler temperature and the steam vent temperature should rise. A nominal vent temp should be 120° F to 135° F.

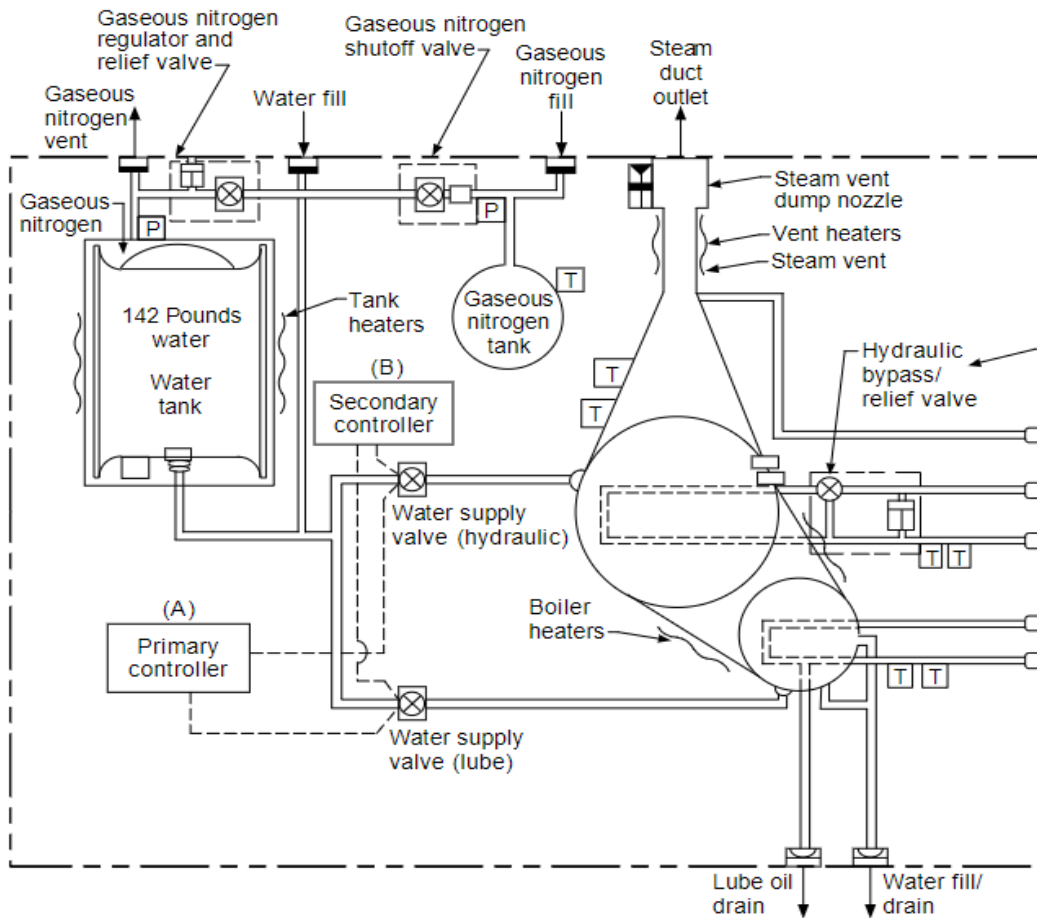

WATER SPRAY BOILER SYSTEM

2.3 Hydraulic Components

The Hydraulic System consists of multiple components that work together to provide hydraulic pressure to position actuators throughout the vehicle. These components include:

2.3.1 Main Hydraulic Pump: The main hydraulic pump for each hydraulic system is a variable displacement type that operates at approximately 3,900 rpm. Each pump has an electrically operated depressurization valve that is controlled by its corresponding HYD MAIN PUMP PRESS 1, 2, or 3 switch on panel 1. When the switch is positioned to LOW, the valve is energized to reduce the main hydraulic pump pressure from its nominal range of 2,900 to 3,100 psi output to a nominal range of 500 to 1,000 psi to reduce the APU torque requirements during the start of the APU.

After an APU has been started, the corresponding HYD MAIN PUMP PRESS switch is positioned from LOW to NORMAL allowing for full hydraulic pressure output. Main pump outlet pressure (HYD PRESSURE) can be seen by the crew on the System Summary 1 display.

2.3.2 Circulation Pump: The circulation pump is actually two fixed-displacement gear-type pumps in tandem, driven by a single motor. One is a high pressure, low-volume pump, which is used to maintain accumulator pressure. The other is a low pressure, high-volume pump, which is used to circulate hydraulic fluid through the orbiter hydraulic lines while the hydraulic system is inactive in orbit in order to warm up cold spots.

Each circulation pump can be manually turned on or off with the corresponding HYD CIRC PUMP switch on panel 1. If the switch is placed in GPC, the pump will be activated and deactivated by the GPC according to a control program based on certain hydraulic line temperatures and/or accumulator pressure. The circulation pump pressure and temperature can be found on System Summary 1.

2.3.3 Hydraulic Accumulator: The accumulator is a bellows type, precharged with gaseous nitrogen to 1700 psig at 70° F. The gaseous nitrogen capacity of each accumulator is 115 cubic inches, and the hydraulic volume is 51 cubic inches.

2.4 APU/HYD Mission Details

During pre-launch the WSB controllers are powered up at launch minus 5 minutes, and the boiler water tanks are pressurized in preparation for APU activation. The Hydraulic main pump is set to low to allow for an easier APU start up. The APU is powered on, and the fuel tanks are opened. The APUs operate during the ascent phase and continue to operate through main engine cutoff. After MECO, the APUs and WSBs are shut down. During the de-orbit procedure, the APU/HYD systems are configured. The WSBs and APUs are then activated to prepare the system for operation during atmospheric entry.

2.5 APU/HYD Caution and Warning System

APU/HYD ANNUNCIATOR PANEL SCHEMATIC

O2 PRESS	H ₂ PRESS	SMOKE / FIRE	LANDING SYS	FUEL CELL TEMP
CABIN ATM	H ₂ /O ₂ HEATER TEMP	MAIN BUS VOLTAGE	AC VOLTAGE	AC O/U LOAD
FREON LOOP	AV BAY/CABIN AIR	IMU	RCS FWD	RCS JET
H ₂ O LOOP	SRB LEFT	MAIN ENGINE LEFT	RCS LEFT	RCS RIGHT
PAYLOAD BAY	SRB RIGHT	MAIN ENGINE CNTR	OMS LEFT	OMS RIGHT
PAYLOAD	GPC	MAIN ENGINE RIGHT	NAV SYSTEM	OMS TVC
ALARM	APU TEMP	APU SPEED	H ₂ O SPRAY BOILER	HYD PRESS

The Orbiter APU/HYD caution and warning system is located on the Flight Engineer Data Panel in the annunciator matrix. APU/HYD alerts can be caution (yellow) or warning (red). Caution lights may indicate a system value out of nominal but still within accepted parameters. Warning lights indicate a malfunction in the system that must be repaired. These alerts can be used in conjunction with notifications listed in the information box (Blue Box) on the Basic Control Data Panel (Pilot's Panel) to complete emergency procedures.

APU SPEED: Indicates an APU (1, 2, or 3) speed greater than or less than a specified percentage of the designed speed.

APU TEMP: Indicates an APU (1, 2, or 3) exhaust gas temperature or lube oil temperature out of limits.

H2O SPRAY BOILER: Indicates a water spray boiler (1, 2 or 3) parameter is out of limits.

APU/HYD Summary

Notes:

- The APU is a hydrazine-fueled, turbine-driven power unit that generates mechanical shaft power to drive a hydraulic pump that produces pressure for the orbiter's hydraulic system.
- The three orbiter hydraulic systems provide pressure to position hydraulic actuators for: SSME control valves, moving orbiter aerosurfaces, retracting ET disconnect umbilicals, deploying landing gear, and providing brake power, anti-skid, and nose wheel steering.
- The APUs are located in the aft fuselage of the orbiter.
- Each APU/HYD system has an independent water spray boiler for APU lube oil and hydraulic fluid cooling.
- The three APUs are started 5 minutes before lift-off. They continue to operate throughout the launch phase and are shut down after the main engine cutoff. The APUs are restarted for entry.
- Each APU fuel tank load is approximately 325 pounds of hydrazine.
- APU/HYD controls are located on panels 1 and 5.
- Displays containing APU/HYD information can be found on System Summaries 1 and 3.

Rules of Thumb:

- APU fuel usage rates vary with loading, but average 1% per minute (3 to 3.5 lb/minute). Usage rates are reduced by about half if the hydraulic main pump is taken to low pressure (HYD MAIN PUMP PRESS switch on panel 1 set to LOW)
- The APU injector cooling tank shared by all three APUs contains enough water for 21 minutes of continuous flow. This is enough for six complete APU/HYD cycles.
- If all water spray boiler cooling is lost to the lube oil after an APU reaches full operating temperatures, only 2 to 3 minutes of operating time are available before bearing seizure occurs.

3 CAUTION AND WARNING SYSTEM (C/W)

3.1 Introduction

The Caution and Warning System warns the crew of conditions that may create a hazard to orbiter operation and/or crew. Under certain circumstances, the system also alerts the crew to situations that require time-critical procedures to correct them. The system uses data such as temperature, pressure, flow rates, and switch positions to determine whether there is an alarm situation.

The system consists of software and electronics that provide the crew with visual and audio cues when a system exceeds predefined operating limits. Visual cues consist of a red MASTER ALARM light, red indicator lights for the affected system, and fault messages located in the informational panel. The audio cue is sent to the communications system for distribution to flight crew headsets.

The C/W system interfaces with the auxiliary power units, data processing system, environmental control and life support system, electrical power system, flight control system, guidance and navigation, hydraulics, main propulsion system, reaction control system, orbital maneuvering system, and payloads. Inputs enter the software C/W logic circuitry from the onboard computers through multiplexers/demultiplexers (MDMs) to activate the alarm tone and ALARM indicator.

3.2 C/W Operations

C/W ANNUNCIATOR PANEL SCHEMATIC

O2 PRESS	H₂ PRESS	SMOKE / FIRE	LANDING SYS	FUEL CELL TEMP
CABIN ATM	H₂/O₂ HEATER TEMP	MAIN BUS VOLTAGE	AC VOLTAGE	AC O/U LOAD
FREON LOOP	AV BAY/CABIN AIR	IMU	RCS FWD	RCS JET
H₂O LOOP	SRB LEFT	MAIN ENGINE LEFT	RCS LEFT	RCS RIGHT
PAYLOAD BAY	SRB RIGHT	MAIN ENGINE CNTR	OMS LEFT	OMS RIGHT
PAYLOAD	GPC	MAIN ENGINE RIGHT	NAV SYSTEM	OMS TVC
ALARM	APU TEMP	APU SPEED	H₂O SPRAY BOILER	HYD PRESS

The caution and warning system uses an annunciator panel to denote off nominal conditions based on predefined operating limits.

There are two classes of alerts that may be seen on the annunciator panel:

3.2.1 Caution (Yellow): A yellow alarm light indicates that a system is operating outside the nominal range but still within acceptable limits.

3.2.2 Alarm (Red): A red alarm light indicates that a system is operating outside acceptable limits. This poses an emergency situation and requires immediate attention.

Annunciator Panel Warning Directory

AC O/U LOAD: O/U means Overload or Underload. Overload is indicated by an inverter 1, 2, or 3 phase A, B, or C output of 225 percent overload for 20 sec or 300 percent for 4 to 6 sec. Underload is indicated by an inverter (1, 2, or 3) phase A, B, or C output of 90 percent underload for 20 sec or 80 percent for 4 to 6 sec.

AC VOLTAGE: Indicates AC bus (1, 2, or 3) phase A, B, or C out of limits.

ALARM: Indicates detection of a caution or emergency condition in any of the Annunciator Panel systems. A yellow alarm light indicates a caution condition, while a red alarm light indicates an emergency condition.

APU SPEED: Indicates an APU (1, 2, or 3) speed greater than or less than a specified percentage of the designed speed.

APU TEMP: Indicates an APU (1, 2, or 3) exhaust gas temperature or lube oil temperature out of limits.

AV BAY/CABIN AIR: Indicates out of limits condition on cabin fan DP, AV Bay (1, 2, or 3) air out temp, or cabin heat exchanger air temp.

CABIN ATM: Indicates either cabin pressure, PPO2, O2 flow rate, or N2 flow rate out of limits.

FREON LOOP: Indicates a low Freon loop (1 or 2) flow rate or a temperature out of limits.

FUEL CELL TEMP: Indicates a fuel cell 1, 2, or 3 stack temperature out of limits.

GPC: Indicates General Purpose Computer (1, 2, 3, 4, or 5) has determined itself failed and issued a self-failure discrete alarm.

H2 PRESS: Indicates an H2 Tank (1, 2, 3, or 4) pressure or the H2 kit (Tank 5) pressure out of limits.

H2/O2 HEATER TEMP: Indicates an H2 or O2 Tank (1, 2, 3, or 4) heater temperature or an H2 or O2 kit (Tank 5) heater temperature out of limits.

H2O LOOP: Indicates an out of limits condition on H2O loop (1 or 2) pump out pressure.

H2O SPRAY BOILER: Indicates a water spray boiler (1, 2 or 3) parameter is out of limits.

HYD PRESS: Indicates a hydraulics system (1, 2, or 3) supply pressure out of limits.

IMU: Indicates detection of an inertial measurement unit (IMU) failure or dilemma.

LANDING SYS: A failure in the Landing System Check process has been detected.

MAIN BUS VOLTAGE: Indicates main bus (A, B, or C) voltage is less than 10% or greater than 15% of the nominal voltage.

MAIN ENGINE CNTR: Indicates detection of a center main engine pod fuel tank ullage pressure out of limits, or an engine abnormal (main engine fail to ignite, or early shutdown) condition.

MAIN ENGINE LEFT: Indicates detection of a left main engine pod fuel tank ullage pressure out of limits, or an engine abnormal (main engine fail to ignite, or early shutdown) condition.

MAIN ENGINE RIGHT: Indicates detection of a right main engine pod fuel tank ullage pressure out of limits, or an engine abnormal (main engine fail to ignite, or early shutdown) condition.

NAV SYSTEM: Indicates a failure or parameter out of limits error in the Navigation System components. These components may include: the Star Tracker, IMU, GPS, or Digital Auto Pilot. A NAV SYSTEM error may also indicate a malfunction in the GPCs.

O2 PRESS: Indicates an O2 tank (1, 2, 3, or 4) pressure or the O2 kit (Tank 5) pressure out of limits.

OMS LEFT: Indicates detection of a left OMS pod oxidizer, fuel tank ullage pressure out of limits, or an engine abnormal (OMS engine fail to cutoff, fail to ignite, or early shutdown) condition.

OMS RIGHT: Indicates detection of a right OMS pod oxidizer, fuel tank ullage pressure out of limits, or engine abnormal (OMS engine fail to ignite, or early shutdown) condition.

OMS TVC: Indicates detection of an OMS pitch or yaw gimbal failure. An OMS TVC failure may indicate a failure in the GPC. OMS TVC failure may precipitate a LEFT or RIGHT OMS failure.

PAYLOAD: Indicates detection of a payload object parameter input out of limits.

PAYLOAD BAY: Indicates detection of payload bay doors, radiators or Ku Antenna movement parameters out of limits.

RCS FWD: Indicates detection of an out of limits condition on a forward RCS oxidizer tank ullage pressure, fuel tank ullage pressure, or forward oxidizer or fuel leak.

RCS JET: Indicates detection of an RCS jet failed on, failed off, or leaking.

RCS LEFT: Indicates detection of a left RCS oxidizer, fuel tank ullage pressure out of limits, or left oxidizer or fuel leak.

RCS RIGHT: Indicates detection of a right RCS oxidizer, fuel tank ullage pressure out of limits, or right oxidizer or fuel tank leak.

SMOKE / FIRE: Smoke and/or fire detector in the cabin, AV Bay, Payload Bay, or Space Lab has activated.

SRB LEFT: Indicates detection of a left Solid Rocket Booster engine abnormal status (fail to ignite, or early shutdown) condition.

SRB RIGHT: Indicates detection of a right Solid Rocket Booster engine abnormal status (fail to ignite, or early shutdown) condition.

C/W Summary

Notes:

- The Caution and Warning System warns the crew of conditions that may create a hazard to orbiter operation and/or crew.
- The C/W system uses an annunciator panel to denote off nominal conditions based on predefined operating limits.
- A yellow alarm light indicates that a system is operating outside the nominal range but still within acceptable limits.
- A red alarm light indicates that a system is operating outside acceptable limits. This poses an emergency situation and requires immediate attention.

Rules of Thumb:

- Crewmembers should reset the master alarm as quickly as possible after review to avoid covering other alerts.
- The fault summary should be reviewed regularly to avoid missed fault messages.

4 COMMUNICATIONS

4.1 Introduction

The orbiter communication system transfers the following types of information:

- Telemetry information to the ground about orbiter operating conditions and configurations, systems, and payloads
- Commands from the ground to the orbiter systems to perform a function or configuration change
- Voice communications among the flight crew members and between the flight crew and mission control

This information is transferred through hardline and radio frequency (RF) links. Hardline refers to wires that connect communicating devices, and RF refers to radio signals. RF communication takes place directly with the ground sites or through a tracking and data relay satellite system (TDRSS).

Direct signals from the ground to the orbiter are referred to as uplinks (UL), and signals from the orbiter to the ground are called downlinks (DL).

The orbiter communication system is divided into several smaller systems:

- S-band phase modulation (PM)
- S-band frequency modulation (FM)
- Ku-band
- Ultrahigh frequency (UHF)

4.2 Communications Operations

All commands are sent to the orbiter from the ground through S-band system uplink or Ku-band system forward link and are routed to the onboard GPC through the network signal processor (NSP) and associated multiplexer/demultiplexer (MDM).

4.2.1 S-Band Phase Modulation: The S-band PM system provides two-way communication between the orbiter and the ground, either directly or through a relay satellite. It provides communication channels for the following functions:

- **Command channel:** used to send commands from ground to orbiter.
- **Voice channel(s):** used for two-way voice communications between ground and orbiter.
- **Telemetry channel:** carries real-time orbiter and payload operational telemetry data to ground.

A characteristic of RF signals in the S-band range is that "line-of-sight" must exist between transmitting and receiving antennas to permit communications. With the availability of the Tracking Data Relay Satellite System (TDRSS) network, communications coverage can be about 80 percent. During critical phases, such as OMS-1/deorbit burns, any zone of exclusion can be covered by scheduling a TDRS Z satellite, thus providing nearly 100 percent communication coverage. If line-of-

sight is obstructed, it may cause a loss of signal (LOS) or “ratty comm” conditions, i.e., when TDRS is oriented off the nose or off the tail of the orbiter.

The S-Band Forward Link is phase modulated on a frequency of either 2,106.4 MHz (secondary) or 2,041.9 MHz (primary). The Return Link is modulated on a frequency of 2,287.5 MHz (secondary) or 2,217.5 MHz (primary). The two frequencies prevent interference if two users are operating at the same time and place.

(Note: The Department of Defense (DoD) S-band is phase modulated on a frequency of either 1,831.8 MHz (secondary) or 1,775.5 MHz (primary) from the Air Force Satellite Control Facility (AFSCF) through its own ground stations (SGLS ground stations).)

S-Band PM Antennas

Four quadrant S-band PM antennas covered with a reusable thermal protection system are located approximately 90° apart on the forward fuselage outer skin of the orbiter. These antennas are the radiating elements for transmitting the S-band PM return link and for receiving the S-band PM forward link.

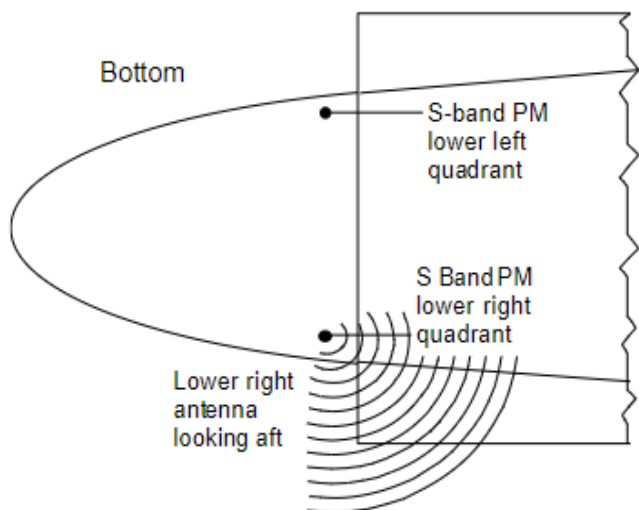
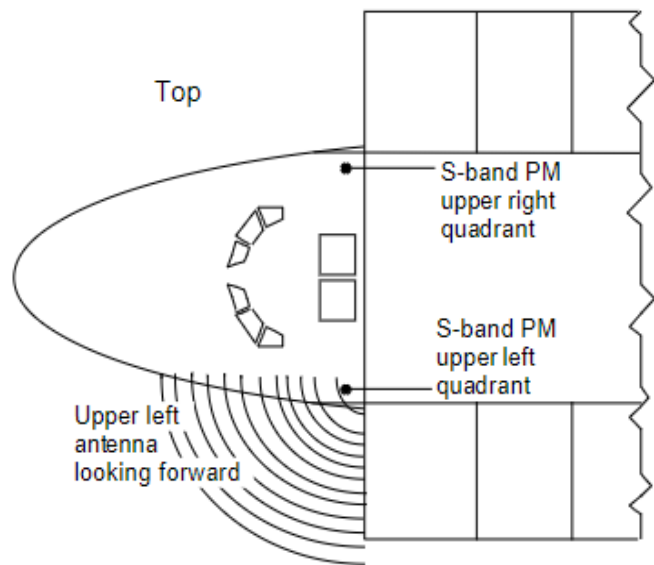

4.2.2 S-Band Frequency Modulation: The S-band FM system cannot receive information; it is used to downlink data from up to seven different sources, one at a time, directly to the ground when there is a line of sight between the orbiter and mission control.

The S-band FM return link can originate from one of two redundant S-band FM transmitters aboard the orbiter. Both transmitters are tuned to 2,250 MHz. The S-band FM return link can be transmitted simultaneously with the S-band PM return link.

The S-band FM return link transfers one of the following:

- Real-time SSME data from the engine interface units during launch at 60 kbps each (ME)
- Real-time video (TV)
- Mass Memory Unit (MMU) dumps of telemetry at 1,024 kbps (MMU 1 or MMU 2)

- DOD data at 16 kbps or 256 kbps in real time or 128 kbps or 1,024 kbps of playback (DOD)

S-Band FM Antennas

Two hemispherical S-band FM antennas covered with a reusable thermal protection system are located on the forward fuselage outer skin of the orbiter approximately 180° apart.

In the GPC mode, the onboard SM computer selects the proper hemispherical antenna to be used whenever an S-band FM transmitter is active. The antenna selection is based on the computed line of sight to mission control.

The basic difference between the quadrant and hemispherical antennas is that the hemispherical antennas have a larger beamwidth, whereas the quadrant antennas have a higher antenna gain. The hemispherical antennas are so named because there are two of them, one on the top of the orbiter and one on the bottom.

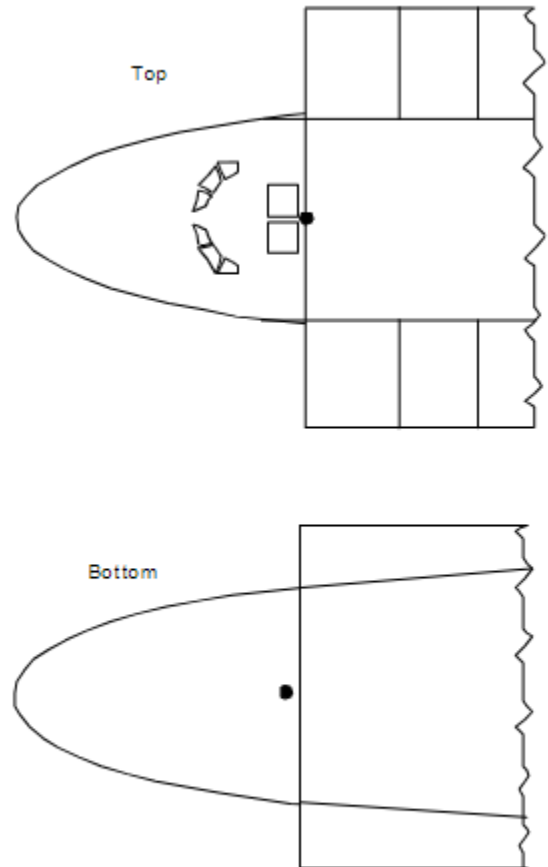

S-Band FM Antenna Locations

4.2.3 Ku-Band System: The Ku-band system

operates between 15,250 MHz and 17,250 MHz. The Ku-band carrier frequencies are 13,755 GHz from the TDRS to the orbiter and 15,003 GHz from the orbiter to the TDRS.

The Ku-band antenna is located in the payload bay. After the payload bay doors are opened, the Ku-band antenna is deployed. Once the antenna is deployed, the system can be used to transmit information to and receive information from the ground through the TDRS. The Ku-band antenna can also be used as a radar system for target tracking objects in space, but it cannot be used simultaneously for Ku-band communications and radar operations.

The Ku-band system can handle more data than the S-band systems. In either of two uplink communications modes, it transmits three channels of data, one of which is the same interleaved voice and telemetry processed by the S-band PM system.

Ku-Band Antenna Deployment and Stowage

After completion of the OMS -1 burn and manual prograde attitude adjustments, the payload bay doors are opened, and radiators are deployed. Once this operation is completed the Ku-Band antenna can be deployed using the Ku ANTENNA switch located on panel 7.

The Ku-band antenna must be stowed before the payload bay doors are closed in preparation for entry. This is done by setting the Ku ANTENNA switch to the STOW position. If the normal STOW procedure cannot properly position the assembly inside the payload bay, the assembly can be jettisoned. In order to jettison, the crew activates the Ku antenna pyro, which causes a guillotine to cut the cables to the deployed assembly and releases a clamp holding it to the pivot assembly.

Ku-Band Deployed Assembly

The Ku-band deployed assembly provides the interface with the TDRS when there is a line of sight between the orbiter and TDRS. The assembly is mounted on the starboard side in the payload bay. The deployed assembly consists of a two-axis, gimbal-mounted, high-gain antenna, an integral gyro assembly, and a radio frequency electronics box.

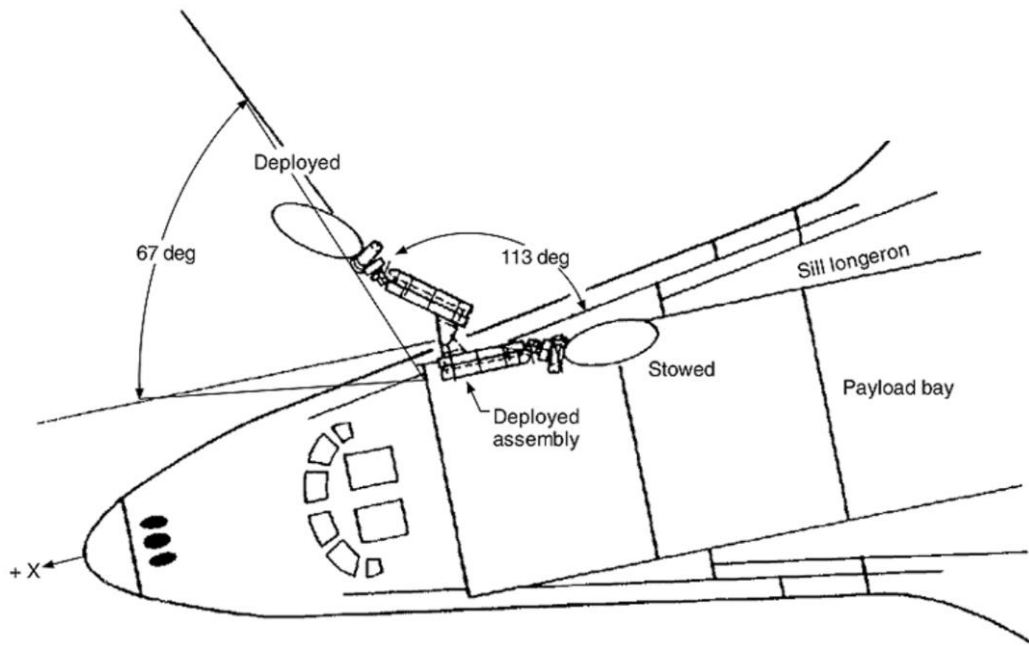

Ku-Band Deployed Assembly Location

4.2.4 Ultrahigh Frequency System: The ultrahigh frequency system actually consists of two separate systems with different capabilities. They are the UHF simplex (SPLX) system and the UHF SSOR system. The UHF simplex, or air traffic control (ATC) system is used as a backup for the S-band PM during ascent and entry phases of flight for communications with Mission control. The UHF system may also be used for air traffic control and two-way voice with chase aircraft during landing operations.

Communications Summary

Notes:

- The orbiter communications system transfers information between the orbiter and the ground, either through hardline or radio frequency links.
- The system is divided into several smaller systems: S-band phase modulation (PM), S band frequency modulation (FM), Ku- band, and UHF.
- The S-band PM system provides two-way communication between the orbiter and the ground. It provides channels for multiple functions: command, voice, telemetry.
- Four quadrant S-band antennas provide a signal in eight directions.
- The S-band FM system cannot receive information. It is used to downlink data directly to the ground.
- There are two hemispherical S-band FM antennas.
- The Ku-band system provides for on-orbit communication between the orbiter and the ground. It can also be used as a radar system for tracking objects in space.
- The Ku-band antenna is deployed when the payload bay doors are opened, and stowed when they are closed.
- The UHF simplex system is used as a backup for the S-band PM and Ku-band voice communications. SSOR is used as the primary communications link with EVA astronauts.

Rules of Thumb:

- When the TDRS has an elevation of greater than $+70^\circ$ or less than -60° relative to the orbiter, there is a risk of degraded communications as the orbiter nose or tail blocks line of sight between the orbiter antenna and the TDRS.
- Flight experience has shown that a good downlink can be sustained with a power output of 65 watts.

5 DATA PROCESSING SYSTEM (DPS)

5.1 Introduction

The DPS, consisting of various hardware components and self-contained software, provides the entire shuttle with computerized monitoring and control.

DPS functions include:

- Supporting the guidance, navigation, and control of the vehicle, including calculations of trajectories, SSME burn data, and vehicle attitude control data.
- Monitoring and controlling vehicle subsystems, such as the electrical power system and the environmental control and life support system.
- Processing vehicle data for the flight crew and for transmission to the ground and allowing ground control of some vehicle systems via transmitted commands.
- Checking data transmission errors and crew control input errors; supporting annunciation of vehicle system failures and out-of-tolerance system conditions.

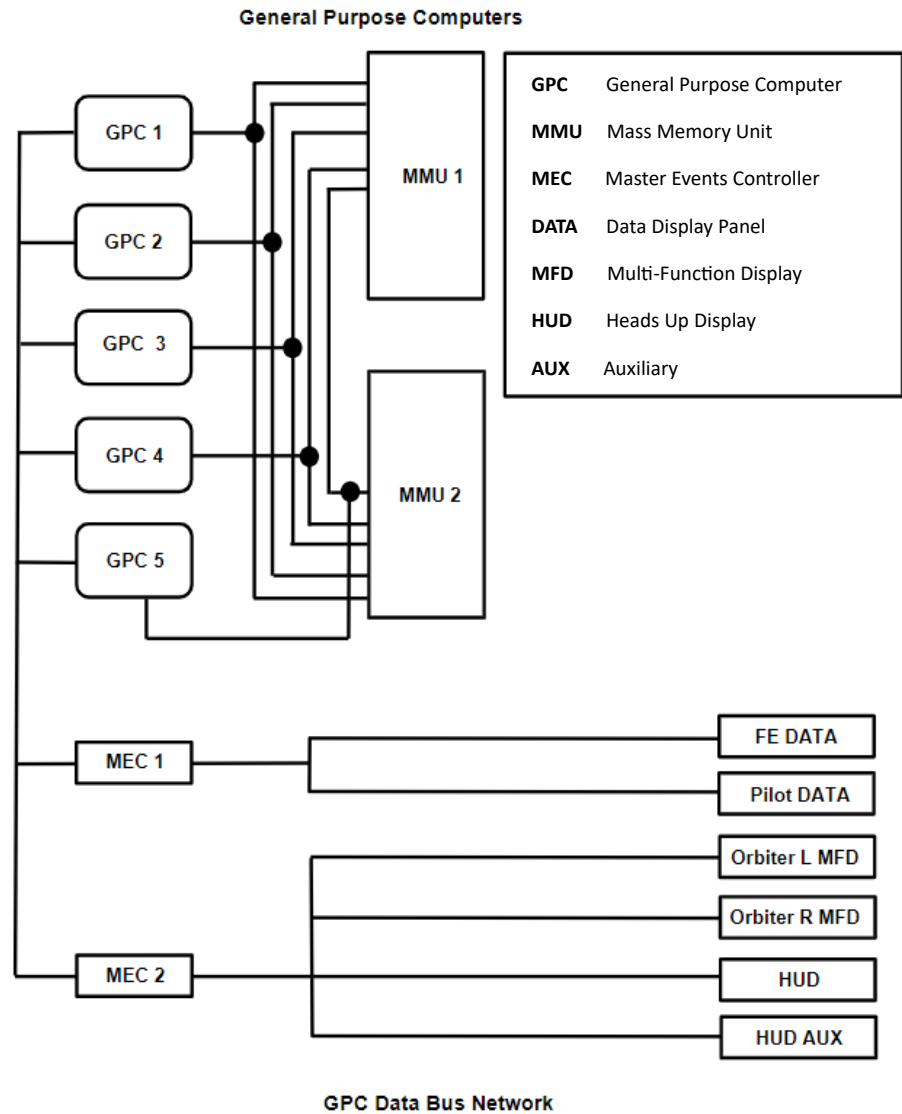

The DPS hardware consists of five general-purpose computers (GPCs), two modular mass memory units (MMUs) for large-volume bulk storage, and a network of serial digital data buses to accommodate the data traffic between the GPCs and vehicle systems. The DPS also includes 20 orbiter and 4 SRB multiplexers/demultiplexers (MDMs) to convert and format data from the various vehicle systems, 2 master events controllers, and a master timing unit.

DPS software accommodates almost every aspect of orbiter operations, including checkout, prelaunch and final countdown for launch, control, and monitoring during launch, ascent, on-orbit activities, entry

and landing, and aborts or other contingency mission phases. A multi-computer mode is used for the critical phases of the mission, such as launch, ascent, orbit, entry, landing, and aborts.

5.2 General Purpose Computers (GPCs)

The orbiter has five identical General Purpose Computers. The GPCs receive and transmit data to and from interfacing hardware via the data bus network. GPCs also contain the software that provides the main on-board data processing capability. Up to four of the systems may run identical software. The fifth system runs different software, programmed by a different company, designed to take control of the vehicle if an error in the primary software or other multiple failures cause a loss of vehicle control. The software utilized by the four primary GPCs is referred to as PASS (primary avionics software system); the fifth GPC is referred to as BFS (backup flight system).

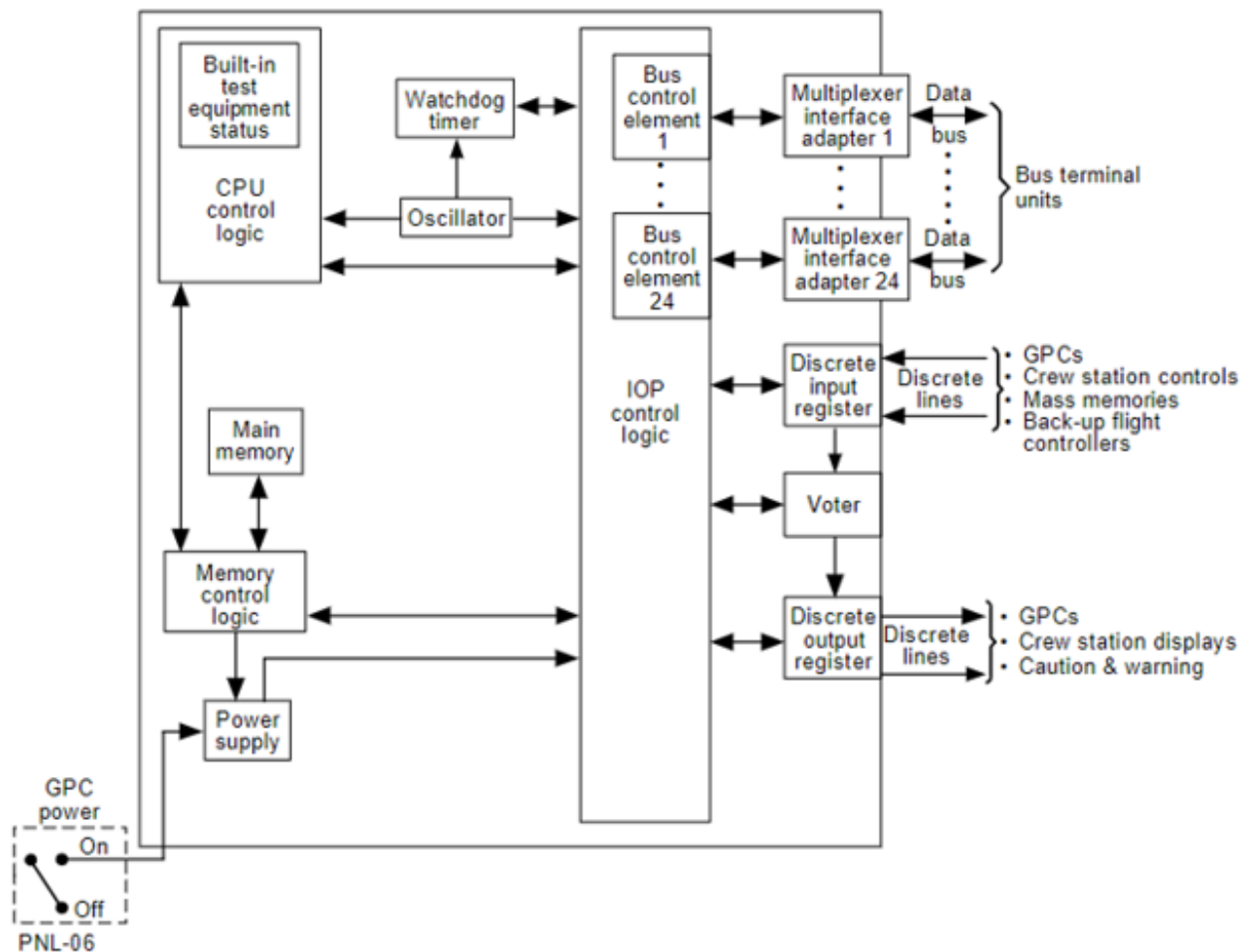

General Purpose Computer Functional Block Diagram

GPCs 1 and 4 are located in avionics bay 1, GPCs 2 and 5 are located in avionics bay 2, and GPC 3 is located in avionics bay 3. The GPCs receive forced-air cooling from an avionics bay fan. (There are two fans in each avionics bay, but only one is powered at a time.)

CAUTION: If both fans in an avionics bay fail, the computers will overheat within a short amount of time after which their operation cannot be relied upon. An operating GPC may or may not survive beyond the certifiable thermal limits.

Each GPC consists of two components, a central processing unit (CPU) and an input/output processor (IOP) stored in one avionics box.

- The CPU controls access to GPC main memory for data storage and software execution and executes instructions to control vehicle systems and manipulate data.
- The IOP formats and transmits commands to the vehicle systems, receives and validates response data transmissions from the vehicle systems, and maintains the status of interfaces with the CPU and the other GPCs.

Each GPC maintains an internal clock to keep track of Greenwich mean time (GMT) and mission elapsed time (MET) as a backup to the timing signal from the master timing unit (MTU).

The PASS GPCs use a hardware "voter" to monitor discrete inputs from the other GPCs. Should a GPC receive a fail vote from two or more of the other GPCs, it will cause the GPC to annunciate a self-fail indication that also causes the GPC to inhibit any fail votes of its own against the other GPCs.

GPC Controls: Each GPC has a GENERAL PURPOSE COMPUTER RUN/HALT switch on panel 7. These switches determine whether that GPC can process software. The switch on all PASS GPCs is normally set to the RUN position. The HALT position initiates a hardware-controlled state in which no software can be executed. A GPC that fails to synchronize with others is either powered OFF or positioned to HALT as soon as possible to prevent the failed computer from outputting erroneous commands. A PASS GPC can be cycled to attempt to reboot. This will initiate a new synchronization attempt and revote. If the faulty GPC continues to fail it should be set to HALT for the duration of the flight.

The backup flight system switch (GPC 5) is positioned to HALT, which precludes it from outputting until it is engaged. Because all BFS software is loaded into the BFS GPC at the same time, the BFS GPC is sometimes referred to as being freeze-dried on orbit when it is placed in HALT. The BFS GPC can be set to RUN in the event that multiple PASS GPCs fail synchronization.

The GPC system also has a MAIN POWER push button. When engaged, it will permit main bus DC power from the three main buses (MN A, MN B, and MN C) to power the 4 PASS GPCs.

NOTE: The BFS GPC is directly connected to the DC main bus and will be unaffected by the MAIN POWER push button.

5.3 Data Bus Network

The data bus network supports the transfer of serial digital commands and data between the GPCs and vehicle systems.

The network has the following groups that perform specific functions:

- Flight-critical (FC) data buses that tie the GPCs to the MMUs and master events controllers (MECs).
- Launch data buses that tie the GPCs to ground support equipment, launch forward, launch aft, launch mid, and SRB Multiplexer/Demultiplexers (MDMs).
- Mass memory data buses for GPC/MMU transactions.
- Display/keyboard (DK) data buses for GPC/IDP transactions.
- Instrumentation/PCMMU (IP) data buses.
- Intercomputer communication (ICC) data buses.

Mass Memory Unit: Each of two MMUs interfaces with its data bus via a multiplexer interface adapter, which functions just like the ones in the GPCs. Each data bus is connected to all five GPCs. MMU switches are located on panel 7 and can be set to ONLINE allowing them to receive and transmit data or OFFLINE to store the current data state.

Launch Data Buses: Two launch data buses are used primarily for ground checkout and launch phase activities. They connect the five GPCs with the ground support equipment/launch processing system.

Master Events Controllers: Each of two MECs interfaces with its data bus via a multiplexer interface adapter, which functions just like the ones in the GPCs. Each data bus is connected to all five GPCs. MEC switches are located on panel 7. They can be set to PROCESS or SHUTDOWN. PROCESS allows data flow between the GPCs and the downstream system instrumentation controlled by the MECs. SHUTDOWN will halt MEC control of any downstream system.

Instrumentation: The instrumentation data buses are controlled by the MECs.

MEC 1 controls the Flight Engineer (FE) and Basic Control (Pilot) Data panels.

MEC 2 controls the Orbiter MFDs and HUD display panels.

Intercomputer Communication Data Buses: There are five intercomputer communication (ICC) data buses. All GPCs processing PASS software exchange status information over the ICC data buses. During launch, ascent, and entry, GPCs 1, 2, 3, and 4 are usually assigned to perform GNC tasks, operating as a redundant set, with GPC 5 as the backup flight system.

Multiplexers/Demultiplexers: The MDMs convert and format (demultiplex) serial digital GPC commands into separate parallel discrete, digital, and analog commands for various vehicle hardware systems. The MDMs also convert and format (multiplex) the discrete, digital, and analog data from vehicle systems into serial digital data for transmission to the GPCs.

5.4 The Keyboard (Macro pad) GPC Interface

The main Macro Pad is composed of a 4 x 6 matrix of 24 pushbutton keys. It is located on the center console on panel 4. The secondary Macro Pad is composed of a 4 x 3 matrix of 12 pushbutton keys and a mini joystick. It is located on the pilot's console next to panel 6. Each Macro Pad is connected to all 5 GPCs.

Main Macro Pad: The main Macro Pad matrix consists of:

- Sixteen alphanumeric keys: 0 through 9 and A through F
- Two sign keys (+ and -)
- Six special function keys

Keys 1-3 are used to input the launch operation commands.

Keys 4-7 are used to control the RCS system.

Keys 8 and 0 are used to control the HUD system.

Key 9 is used to reset the launch MFD.

Keys A-C are used to control the orbiter multifunction displays.

Keys D and E are used to cycle the RCS system.

Key F is used for docking.

The + and – are used to control trim.

CRT	A	B	C
I/O RESET	D	E	F
ITEM	1	2	3
EXEC	4	5	6
DPS	7	8	9
SPEC	-	0	+

Special Function Keys

CRT: is used to cycle the left MFD.

I/O RESET: is used to cycle the HUD.

ITEM: selects the MFD for input commands.

EXEC: executes the current command.

DPS: initiates the terminal dialog input box.

SPEC: Sets the HUD specifications.

LEFT MFD On/Off	MFD Terminal	MFD Surface Mode	MFD HIS
Turn On/Off HUD	RCS Off	Toggle RCS Rot/Lin	Dock/ Undock
Select MFD	OPS 1Program	Ops 2 Program	Ops 3 Program
Execute Program	RCS Kill Rotation	RCS Level	RCS Retrograde
Terminal Dialog Box	RCS Prograde	Re-center HUD View	Reset Pilot Launch MFD
HUD Specs	Trim -	Cycle HUD Settings	Trim +

Secondary Macro Pad: The secondary macro pad matrix consists of:

- Ten alphanumeric keys
- Two special function keys

Keys D-F, 4-9, and 0 are the provide the same function as the corresponding keys on the main Macro Pad

Left and Right Wheel Brake keys are momentary pushbuttons that allow for wheel brake control on landing.

The mini Joystick is available for attitude corrections and flight control should the main joystick at the commander’s station not function properly.

Note: the mini joystick has three axis capabilities. However, the yaw axis which is used by rotating the stick has an infinite rotational capability. It will need to be rotated an equal number of times in each direction to reach the zero point of rotation.

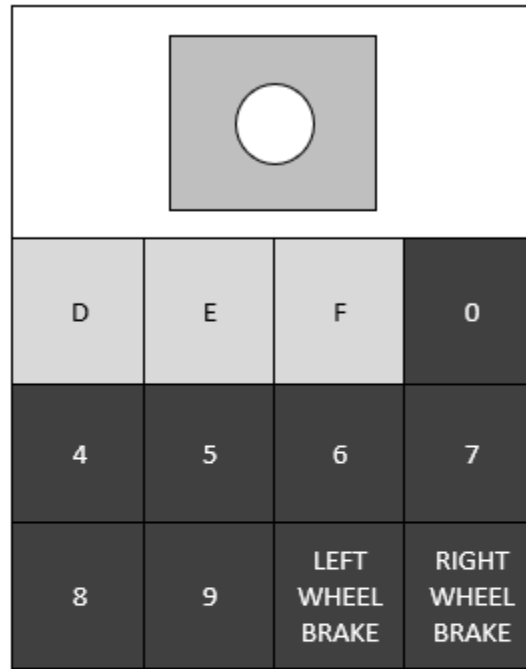

RCS Off	Toggle RCS Rot/Lin	Dock/Undock	Cycle HUD Settings
RCS Kill Rotation	RCS Level	RCS Retrograde	RCS Prograde
Re-center HUD View	Reset Pilot Launch MFD	Left Wheel Brake	Right Wheel Brake

5.5 Data Processing Caution and Warning System

DPS ANNUNCIATOR PANEL SCHEMATIC

O2 PRESS	H ₂ PRESS	SMOKE / FIRE	LANDING SYS	FUEL CELL TEMP
CABIN ATM	H ₂ /O ₂ HEATER TEMP	MAIN BUS VOLTAGE	AC VOLTAGE	AC O/U LOAD
FREON LOOP	AV BAY/CABIN AIR	IMU	RCS FWD	RCS JET
H ₂ O LOOP	SRB LEFT	MAIN ENGINE LEFT	RCS LEFT	RCS RIGHT
PAYLOAD BAY	SRB RIGHT	MAIN ENGINE CNTR	OMS LEFT	OMS RIGHT
PAYLOAD	GPC	MAIN ENGINE RIGHT	NAV SYSTEM	OMS TVC
ALARM	APU TEMP	APU SPEED	H ₂ O SPRAY BOILER	HYD PRESS

The Orbiter GPC caution and warning system is located on the Flight Engineer Data Panel in the annunciator matrix. GPC alerts can be caution (yellow) or warning (red). Caution lights may indicate a system value out of nominal but still within accepted parameters. Warning lights indicate a malfunction in the system that must be repaired. These alerts can be used in conjunction with notifications listed in the information box (Blue Box) on the Basic Control Data Panel (Pilot's Panel) to complete emergency procedures.

GPC: Indicates General Purpose Computer (1, 2, 3, or 4) has determined itself failed and issued a self-fail discrete alarm. GPC alarm may also indicate a functional failure of the backup flight system (GPC 5).

DPS Summary

Notes:

- The DPS combines various hardware components and self-contained software to provide computerized monitoring and control.
- DPS hardware includes 5 GPCs, 2 mass memory units, a data bus network, MDMs, and other specialized equipment.
- Each of the five GPCs consists of a CPU and an IOP in one avionics box. Four of the GPCs are loaded with identical PASS software; the fifth is loaded with different software, the BFS.
- The data bus network transfers data between the GPCs and vehicle systems.
- The MDMs convert data to appropriate formats for transfer between the GPCs and vehicle systems.
- Two mass memory units provide bulk storage for software and data.
- The four PASS GPCs control all GNC functions during ascent/entry mission phases; the fifth GPC is loaded with backup flight system (BFS) software to take over in case of PASS GPC failure.
- Most DPS control switches are located on panel 7.

Rules of Thumb:

- Always HALT fail to sync GPCs and cycle to attempt a reboot sequence.
- During OPS transitions, keep "hands off" everything, including all switches and keyboard entries.
- Clear the master alarm as soon as you have seen the error messages to avoid missing new alarms.
- It is important to be able to identify GPC failures. The information you provide will affect Mission Control analysis and its ability to plan for subsequent failure.
- Keyboard entries should be checked between each command for proper input. Holding the pushbutton may cause errant commands to be entered.

6 ELECTRICAL POWER SYSTEM

6.1 Introduction

The electrical power system (EPS) consists of the equipment and reactants that produce electrical power for distribution throughout the orbiter vehicle and fulfill all the orbiter external tank, solid rocket booster, and payload power requirements, when not connected to ground support equipment. The EPS operates during all phases of flight. For nominal operations, very little flight crew interaction is required by the EPS.

The EPS is functionally divided into three subsystems:

- Power reactants storage and distribution (PRSD)
- Three fuel cell (FC) power plants
- Electrical power distribution and control (EPDC).

Through a chemical reaction, the three FCs generate all 28-volt direct-current electrical power for the vehicle from launch minus 50 seconds through landing rollout. Prior to that, electrical power is provided by ground power supplies and the onboard FCs.

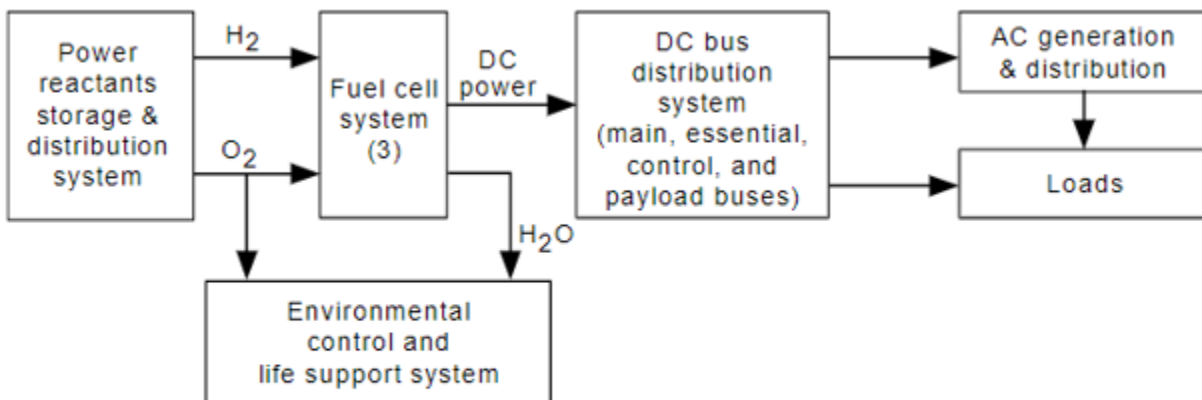

The Electrical Power System

6.2 Power Reactants Storage and Distribution System

The PRSD system stores the reactants (cryogenic hydrogen and oxygen) and supplies them to the three FCs that generate all the electrical power for the vehicle during all mission phases. In addition, the subsystem supplies cryogenic oxygen to the environmental control and life support system (ECLSS) for crew cabin pressurization.

Reactant Storage: The hydrogen and oxygen are stored in tanks at cryogenic temperatures (-285°F for liquid oxygen and 420° F for liquid hydrogen) and supercritical pressures (above 731 psia for oxygen and above 188 psia for hydrogen). Each tank has sensors that measure temperature, pressure, and quantity.

The tanks are grouped in sets of one hydrogen and one oxygen tank. The number of tank sets installed depends on the specific mission requirement and vehicle. Up to five tank sets can be installed in the mid-fuselage under the payload bay liner.

All oxygen tanks are identical and consist of an inner pressure vessel and an outer shell. Each tank has a volume of 11.2 cubic feet and stores up to 781 pounds of oxygen.

All hydrogen tanks are also identical. The volume of each tank is 21.39 cubic feet, and each stores up to 92 pounds of hydrogen.

Reactant Distribution: The cryogenic reactants flow from the tanks through a relief valve/filter package module. They then flow to the FCs through a common manifold system. Hydrogen is supplied to the manifold from the tank at a pressure of 200 to 243 psia and oxygen is supplied at 803 to 883 psia. The pressure of the reactants will be essentially the same at the FC interface as it is in the tanks, since only a small decrease in pressure occurs in the distribution system.

Each module contains a manifold valve and FC reactant valves. Each FC has two reactant valves—one for hydrogen and one for oxygen. The oxygen valve modules also contain supply valves providing oxygen to the environmental control and life support system atmosphere pressure control systems 1 and 2. The valves are controlled by the FUEL CELL (1/3/2) REAC VLV, MANIFOLD (A/B) VLV, and ECS (1/2) VLV switches located on panel 9.

When the REAC switch is positioned to OPEN, the hydrogen and oxygen reactant valves for that FC are opened and reactants are allowed to flow from the manifold into the FC. When the switch is positioned to CLOSE, the hydrogen and oxygen reactant valves for that FC are closed, isolating the reactants from the FC, and rendering that FC inoperative.

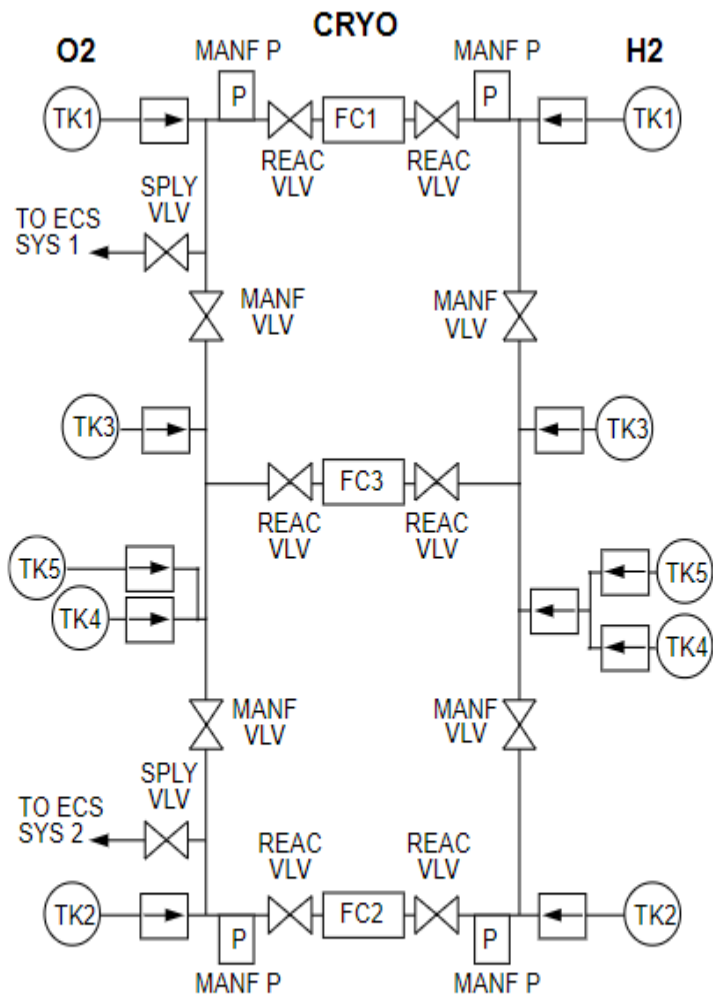

The PRSD System

When the two hydrogen and two oxygen manifold valves are in the CLOSE position, FC 1 receives reactants from cryogenic tank set 1, FC 2 receives reactants from cryogenic tank set 2, and FC 3 receives reactants from cryogenic tank sets 3 and above. When the manifold valves are positioned to OPEN, all tanks are able to supply the FCs.

ECLSS atmosphere pressure control system 1 receives O₂ from oxygen tank 1, and system 2 receives O₂ from oxygen tank 2.

6.3 Fuel Cell System

The three FCs are located under the payload bay liner in the forward portion of the orbiter's mid-fuselage. Each FC is reusable and restartable. The three FCs are individually coupled to the PRSD subsystem, the active thermal control system (ATCS), the supply water storage subsystem, and the electrical power distribution and control (EPDC) subsystem.

The FCs generate heat and water as by-products of electrical power generation. The excess heat is directed to the FC heat exchanger, where it is rejected to the Freon coolant loops. The water is directed to the supply water storage subsystem for the environmental control and life support system.

The nominal voltage and current range of each FC is 32 volts DC at 2 kW (61.5 amps), decreasing to 27.5 volts DC at 12 kW (436 amps). Each is capable of supplying up to 10 kW maximum continuous power in nominal situations, 12 kW continuously in off nominal situations (with one or more FCs failed), and up to 16 kW for 10 minutes.

The orbiter's three FCs operate as independent electrical power sources, each supplying its own isolated, simultaneously operating DC bus. Each FC consists of a power section and an accessory section. The power section is where hydrogen and oxygen are transformed into electrical power, water, and heat. The accessory section monitors the reactant flow, removes waste heat and water from the chemical reaction, and controls the temperature of the stack.

The FC generates power through an electrochemical reaction of hydrogen and oxygen. At the hydrogen electrode (anode), hydrogen is oxidized according to the following reaction:



forming water and releasing electrons. At the oxygen electrode (cathode), oxygen is reduced in the presence of water. It forms hydroxyl ions according to the following relationship:



The net reaction consumes one oxygen molecule and two hydrogen molecules in the production of two water molecules, with electricity and heat formed as by-products of the reaction.

Water Removal: Water and electricity are the products of the oxidation/reduction reaction of oxygen and hydrogen that takes place in the FCs. The water must be removed, or the cells will become saturated with water, decreasing reaction efficiency. After being condensed, the liquid water is

separated from the hydrogen by the hydrogen pump/water separator and discharged from the FC to be stored in the ECLSS potable water storage tanks. Product water is routed to tank A; when tank A is full, it is routed to tank B, then tanks C and D. An alternate water delivery path is also available to deliver water to the ECLSS tanks if the primary path is lost. If the water tanks are full, or there is line blockage, the water relief valves open at 45 psia to allow the water to vent overboard through the water relief line and nozzle.

Fuel Cell Monitoring System: The fuel cell monitoring system (FCMS) is a data collection system that provides insight into the single cell voltages in the orbiter FC power plants. The program records voltage in each individual cell as well as in all three FCs. Average output can be found in the environmental box on the Basic Control Data Panel. Individual output for FCs (1, 2, 3) can be found in System Summary 2.

6.4 Electrical Power Distribution and Control (EPDC)

The electrical power distribution and control (EPDC) subsystem controls and distributes AC and DC electrical power to the orbiter subsystems, the solid rocket boosters, the external tank, and payloads.

Electrical Power Distribution Schematic

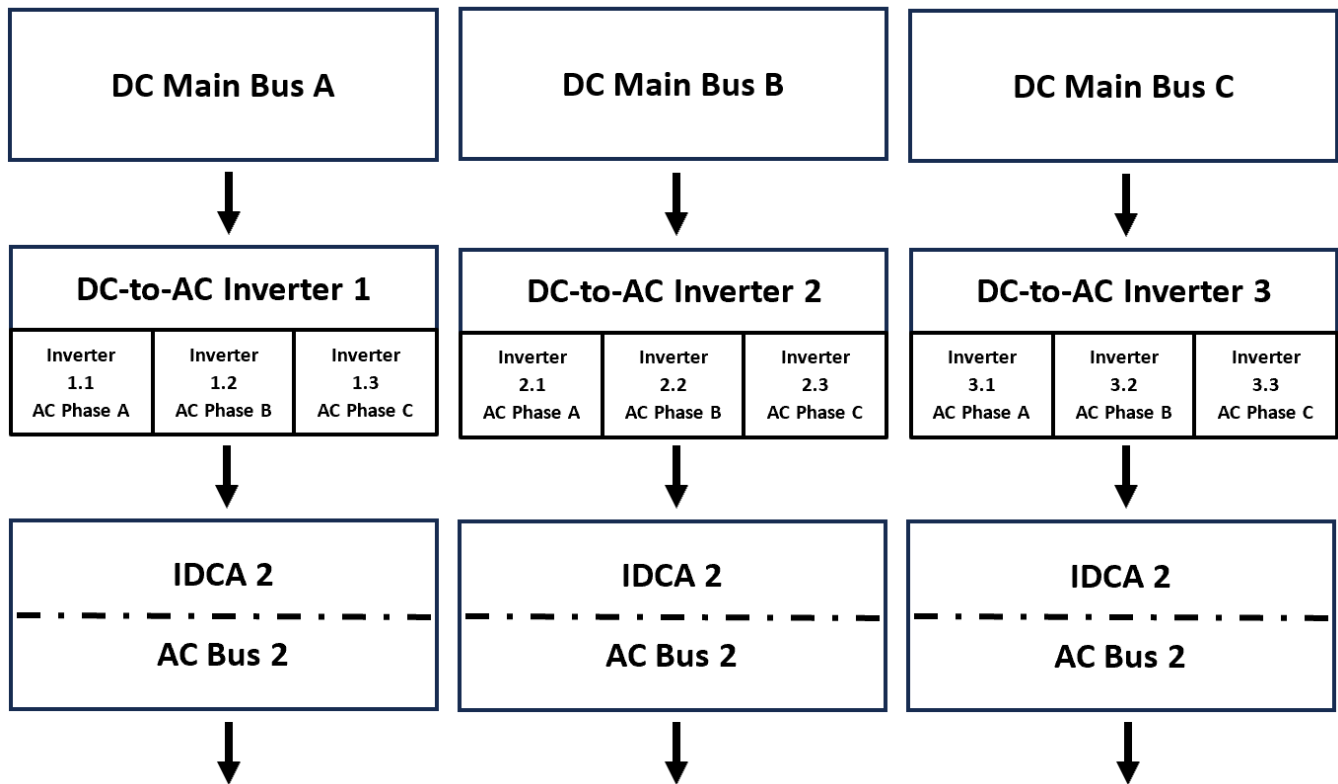

The 28 volts DC generated by each of the three FCs is distributed to a main DC bus. The three main DC buses are the prime sources of power for the vehicle's DC loads. Each DC main bus supplies power to three solid-state (static), single-phase inverters, which in turn powers their respective AC bus. These three inverters are phase sequenced with each other to provide three-phase alternating-current (AC). Thus, a total of nine inverters convert DC power to 117 volt (rms), 400-hertz AC power for distribution to three AC buses for the vehicle's AC loads.

Bus System: The three main DC buses are Main Bus A (MN A), Main Bus B (MN B), and Main Bus C (MN C). Three AC buses, AC 1, AC 2, and AC 3, supply AC power to the AC loads. Depending on the criticality of orbiter electrical equipment, some electrical loads may receive redundant power from two or three main buses.

Main Bus Tie Bar: The DC main bus tie bar is a secondary electrical bus that is not normally energized. It provides a method to connect (or 'tie') the three independent Main DC Buses A, B, and C if power transfer between the buses becomes necessary.

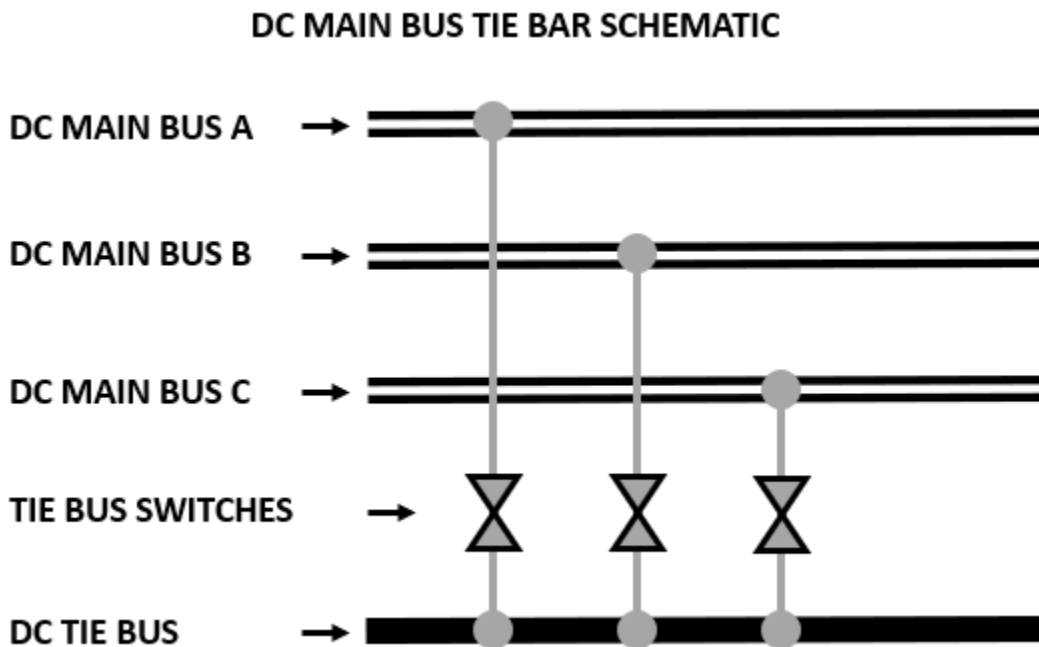

6.4.1 **DC Power System:** The main buses distribute DC electrical power from the FCs to locations throughout the orbiter.

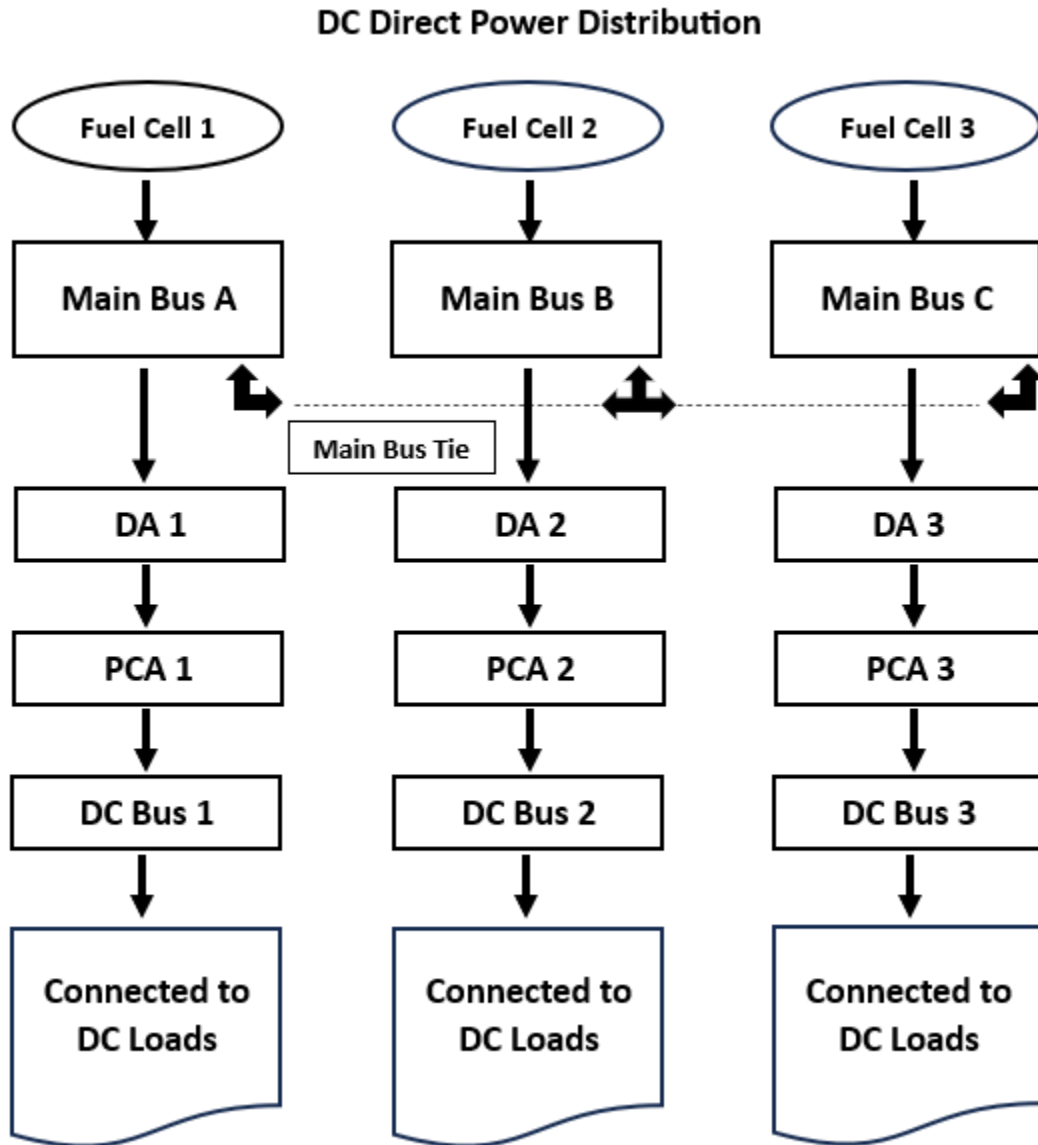

Distribution Assemblies: Three distribution assemblies handle the routing of main bus power. The DC power generated by each of the FCs is supplied to a corresponding distribution assembly (DA). FC 1 powers DA 1, FC 2 powers DA 2, and FC 3 powers DA 3. Each distribution assembly contains fuses, relays, and remotely controlled motor-driven switches called power contactors. The DAs control and distribute DC power to a corresponding forward power controller assembly (PCA 1), mid power controller assembly (PCA 2), and aft power controller assembly (PCA 3).

Power Controller Assemblies: Each of the forward, mid, and aft power controller assemblies supplies and distributes DC power to a corresponding set of DC loads.

DC Bus Loads: DC power is used to control low voltage systems. In most cases this power is used to run switches and relays to control throughput of the higher voltage AC power for control of mechanical systems. DC bus loads include power for flight deck, mid deck, and aft switch panels, Primary and Secondary system controllers, and remote power relays.

Remote Power Relays: The RPRs are solid-state switching devices; they have the capability to limit the output current to a maximum of 150 percent of rated value for 2 to 3 seconds. Within 3 seconds, the RPR will trip, removing the output current. To restore power to the load, the RPR must be reset. This is accomplished by cycling a control switch located on the flight engineer panel 8 (touch screen).

RPRs are used for doors, latches, and actuators, as well as OMS/RCS valves.

DC Bus 1: Bus 1 control loads include:

- 1) Flight Deck Power Panels
- 2) Primary Systems Control
- 3) Forward Remote Power Relays
 - a) Master Relay
 - b) Fwd L/R Vent Doors
 - c) Star Tracker Y/Z Doors
 - d) Air Data L/R Doors
 - e) Fwd RCS Manifold Valves
 - f) Fwd RCS Tank Isol Valves

DC Bus 2: Bus 2 control loads include:

- 1) Mid Deck Power Panels
- 2) Secondary Systems Control
- 3) Mid Remote Power Relays
 - a) Master Relay
 - b) Mid L/R Vent Doors
 - c) Payload Bay Doors
 - d) Payload Bay Door Latches
 - e) Payload Bay Retention Latches
 - f) Radiator Deployment Actuators

DC Bus 3: Bus 3 control loads include:

- 1) Aft Power Panels
- 2) Aft Remote Power Relays
 - a) Master Relay
 - b) Aft Vent Doors
 - c) Aft OMS/RCS Manifold Valves
 - d) Aft OMS/RCS Tank Isol Valves
 - e) Aft OMS/RCS Cross-feed Valves

6.4.2 AC Power System: AC power is generated and made available to system loads by the EPDC subsystem using three independent AC buses, AC 1, AC 2, and AC 3.

The AC power system includes the AC inverters for DC conversion to AC and inverter distribution and control assemblies containing the AC buses and the AC bus sensors. The AC power is

distributed from the inverter distribution and controller assemblies to the flight and middeck display and control panels and from the motor controller assemblies to the three-phase motor loads.

AC Power Distribution Schematic

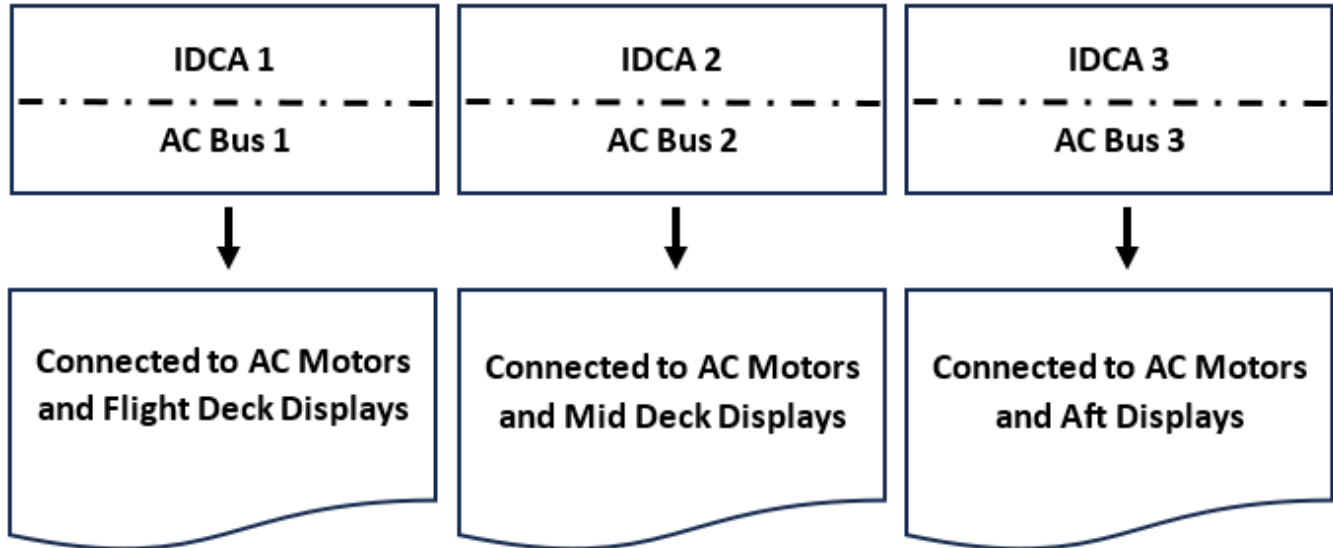

AC Bus Loads: AC power is used to control high voltage systems such as the Primary and Secondary Avionics controls as well as load and motor controllers for various systems.

Motor Controllers: There are 10 motor controller assemblies used on the orbiter. Their only function is to supply AC power to noncontinuous AC loads for AC motors used for vent doors, air data probe, star tracker doors, payload bay doors, payload bay latches, ET doors and latches, and reaction control system/orbital maneuvering system motor-actuated valves.

<p>AC Bus 1: control loads include:</p> <ol style="list-style-type: none"> 1) Primary Avionics 2) Forward L/R Vent Doors 3) Star Tracker Y/Z Doors 4) L/R Air Data Doors 5) Forward RCS Manifold Valves 6) Forward RCS Tank Isol Valves 	<p>AC Bus 2: control loads include:</p> <ol style="list-style-type: none"> 1) Mid L/R Vent Doors 2) Payload Bay Doors 3) Payload Bay Door Latches 4) Bay Retention Latches 5) Radiator Deploy Actuators 	<p>AC Bus 3: control loads include:</p> <ol style="list-style-type: none"> 1) Secondary Avionics 2) Aft Vent Doors 3) Aft OMS/RCS Manifold Valve 4) Aft OMS/RCS Tank Isol Valves 5) Aft OMS/RCS Crossfeed Valves
--	---	--

6.5 EPS Operations

Pre-Launch: During prelaunch operations, the onboard Fuel Cell reactants (oxygen and hydrogen) are supplied by ground support equipment to assure a full load of onboard reactants before lift-off.

Until T minus 1 minute, power to the orbiter is load shared between the FCs and ground support equipment, even though the FCs are on and capable of supplying power. At approximately T-00:55 ground power is disconnected. Indication of the switchover can be noted on the Pilot Data Panel in the informational text box (Blue Box).

Fuel Cell Operating Modes: The Fuel Cells can be set to Run or Standby using switches located on switch panel 8 (Touch Screen).

Run: When set to Run, Fuel Cells will consume reactants and supply electrical power to AC and DC systems.

Standby: FC Standby consists of removing the electrical loads from a FC but continuing operation of the FC pumps, controls, instrumentation, and valves, while electrical power is supplied by the remaining FCs. A small amount of reactants is used to generate power for the FC internal heaters.

6.6 EPS Caution and Warning System

AC Bus Sensor: The AC buses have a sensor, switch, and circuit breaker for flight crew control. The AC bus sensor monitors each AC phase bus for over or undervoltage, and each phase inverter for an overload signal. O/U is used to denote Overload and/or Underload. Overload is indicated by an inverter 1, 2, or 3 phase A, B, or C output of 225 percent over nominal load for 20 sec or 300 percent for 4 to 6 sec. Underload is indicated by an inverter 1, 2, or 3 phase A, B, or C output of 90 percent under nominal load for 20 sec or 80 percent for 4 to 6 sec.

When the AC BUS SENSOR switch is in the AUTO position, and an overload or underload condition occurs, the AC bus sensor will illuminate the AC VOLTAGE O/U annunciator light and trip off (disconnect) the inverter from its respective phase bus for the bus/inverter causing the problem.

When the AC BUS SENSOR switch is in the MONITOR position, the AC bus sensor will monitor for an overload, overvoltage, and undervoltage and illuminate the applicable caution and warning light; but it will not trip off the phase bus/inverter causing the problem.

EPS ANNUNCIATOR PANEL SCHEMATIC

O ₂ PRESS	H ₂ PRESS	SMOKE / FIRE	LANDING SYS	FUEL CELL TEMP
CABIN ATM	H ₂ /O ₂ HEATER TEMP	MAIN BUS VOLTAGE	AC VOLTAGE	AC O/U LOAD
FREON LOOP	AV BAY/CABIN AIR	IMU	RCS FWD	RCS JET
H ₂ O LOOP	SRB LEFT	MAIN ENGINE LEFT	RCS LEFT	RCS RIGHT
PAYLOAD BAY	SRB RIGHT	MAIN ENGINE CNTR	OMS LEFT	OMS RIGHT
PAYLOAD	GPC	MAIN ENGINE RIGHT	NAV SYSTEM	OMS TVC
ALARM	APU TEMP	APU SPEED	H ₂ O SPRAY BOILER	HYD PRESS

The Orbiter EPS caution and warning system is located on the Flight Engineer Data Panel in the annunciator matrix. EPS alerts can be caution (yellow) or warning (red). Caution lights may indicate a system value out of nominal but still within accepted parameters. Warning lights indicate a malfunction in the system that must be repaired. These alerts can be used in conjunction with notifications listed in the information box (Blue Box) on the Basic Control Data Panel (Pilot's Panel) to complete emergency procedures.

AC O/U LOAD: O/U means Overload or Underload. Overload is indicated by an inverter (1, 2, or 3) phase A, B, or C output of 225 percent overload for 20 sec or 300 percent for 4 to 6 sec. Underload is indicated by an inverter (1, 2, or 3) phase A, B, or C output of 90 percent underload for 20 sec or 80 percent for 4 to 6 sec.

AC VOLTAGE: Indicates AC bus (1, 2, or 3) phase A, B, or C out of limits.

FUEL CELL TEMP: Indicates a fuel cell (1, 2, or 3) stack temperature out of limits.

MAIN BUS VOLTAGE: Indicates main bus (A, B, or C) voltage is less than 10% or greater than 15% of the nominal voltage.

EPS Summary

Notes:

- The EPS operates during all flight phases and consists of the equipment and reactants that produce electrical power for distribution throughout the orbiter.
- The FC picks up full power load support after ground equipment is turned off at T minus 50 seconds, supporting power requirements for the solid rocket booster, orbiter, and payloads.
- EPS subsystems are: power reactants storage and distribution, FCs, and electrical power distribution and control.
- The Power Reactants Storage and Distribution system stores cryogenic hydrogen and oxygen and supplies them to the FCs. It also supplies oxygen to the ECLSS.
- The FC system (three FCs) transforms hydrogen and oxygen to electricity by a chemical reaction. The system supplies potable water to the ECLSS and consists of power and accessory sections.
- The electrical power distribution and control system distributes electrical power throughout the orbiter.
- The EPS requires very little flight crew interaction during nominal operations.
- EPS control switches are located on panels: 2, 3, 8, and 9.

Rules of Thumb:

- Loss of cooling to a FC requires immediate crew action to prevent a catastrophic loss of crew/vehicle due to possible FC fire and explosion.
- Any interruption of continuous AC power during ascent will result in the loss of main engine controller redundancy. Reconfiguration of AC powered equipment prior to MECO should be avoided if possible.
- Never connect or reconnect power to a known shorted or failed component; this includes switches, circuit protection device resets, or bus ties.

7 ENVIRONMENTAL CONTROL AND LIFE SUPPORT SYSTEM (ECLSS)

7.1 Introduction

The ECLSS maintains the orbiter's thermal stability and provides a pressurized, habitable environment for the crew and onboard avionics. The ECLSS also manages the storage and disposal of water and crew waste. ECLSS is functionally divided into four systems: Pressure control system (PCS), Atmospheric revitalization system (ARS), Active thermal control system (ATCS), and the Supply and waste-water system.

The crew compartment provides a life-sustaining environment for the flight crew. The cabin volume is 2,475 cubic feet. Most ECLSS parameters can be monitored during ascent and entry on the Basic Control Data Panel (Pilot's Panel) and Flight Engineer's Panel.

- 1 Water coolant loops
- 2 Interchanger heat exchanger
- 3 Payload heat exchanger
- 4 Freon-21 coolant loops
- 5 Fuel cell power plants
- 6 Cargo heat exchanger
- 7 Hydraulic heat exchangers to radiators
- 8 Aft avionics bay and cold plates
- 9 Ground support equipment heat exchanger
- 10 Flash evaporators
- 11 Ammonia boiler
- 12 To radiators
- 13 Midbody cold plates
- 14 Fuel cell heat exchanger to Freon-21 coolant loops
- 15 Freon-21 coolant pumps
- 16 Avionics bays 1, 2, and 3A heat exchangers, fans, and coolant plants

- 17 Inertial measurement units heat exchanger and fans
- 18 Water pumps
- 19 Cabin air to water heat exchanger
- 20 Humidity water separators
- 21 Carbon dioxide absorber
- 22 Cabin fans and check valve assemblies
- 23 Liquid-cooled garment heat exchanger
- 24 Potable water chiller heat exchanger

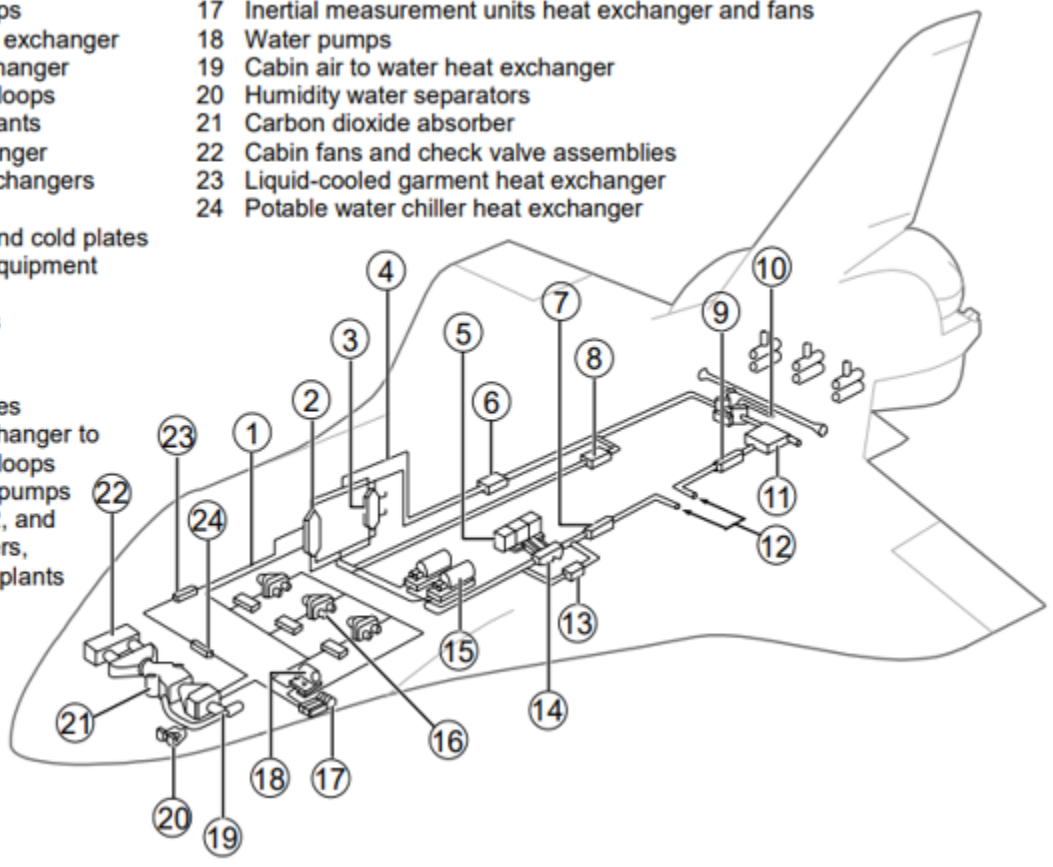

7.2 Pressure Control System (PCS)

The pressure control system normally pressurizes the crew cabin to 14.7 ± 0.2 psia (760 torr). It maintains the cabin at an average 79-percent nitrogen and 21-percent oxygen mixture that closely resembles the atmosphere at sea level on Earth. The system also provides the cabin atmosphere necessary to cool cabin-air-cooled equipment.

The PCS consists of a liquid oxygen storage system and a gaseous nitrogen storage system. The PCS oxygen is supplied from the electrical power system's (EPS) cryogenic oxygen tanks. The cryogenic supercritical oxygen storage system is controlled by electrical heaters within the tanks and supplies oxygen to the ECLSS pressure control system in a gaseous state. The nitrogen storage tanks are serviced to a nominal pressure of 2,964 psia at 80° F. Normal on-orbit operations use one oxygen and one nitrogen supply system.

7.3 Atmospheric Revitalization System (ARS)

The atmospheric revitalization system (ARS) circulates air and water throughout the cabin to control ambient heat, relative humidity, carbon dioxide, and carbon monoxide levels. The ARS also provides cooling for cabin avionics.

Cabin air is circulated around the cabin to remove heat and humidity. The heated air is then ducted to the cabin heat exchanger, where the heat is removed by the water coolant loops. The water coolant loop system collects heat from the cabin heat exchanger, the inertial measurement unit (IMU) heat exchanger, the cold-plated electronic units in the avionics bays, and the avionics bay heat exchangers. The water coolant loop transfers the heat collected to the Freon/water heat exchanger of the active thermal control system. The active thermal control system then expels the heat overboard.

- **Lithium Hydroxide Canisters:** The cabin air leaves the cabin and is directed to each of two lithium hydroxide (LiOH) canisters, where carbon dioxide is removed and activated charcoal removes odors and trace contaminants.

Note: The LiOH canisters are the primary means of carbon dioxide (CO₂) control onboard the orbiter.

7.4 Active Thermal Control System (ATCS)

The active thermal control system (ATCS) provides orbiter heat rejection during all phases of the mission after solid rocket booster separation.

The system consists of two complete, identical Freon coolant loops, cold plate networks for cooling avionics units, liquid/liquid heat exchangers, and three onboard heat sinks: radiators, flash evaporators, and ammonia boilers.

- **Water Loop:** The water coolant loops circulate water through the crew compartment to collect excess heat and transfer it to the Freon coolant loops. The water Loop can be manually controlled using the switch located on Panel 5.

- **Freon Loops:** Two Freon coolant loops transport excess heat from the Freon/water interchanger, fuel cell heat exchanger, payload heat exchanger, and avionics electronic units. The Freon loops then deliver the heat to the heat sinks. The Freon Loop can be manually controlled using the switch located on Panel 5.
- **Radiators:** Radiators act as a heat sink for the coolant loops. The radiator system consists of four radiator panels attached to the inside of each payload bay door. The two forward radiator panels (1 and 2) on each payload bay door are deployable when the doors are opened on orbit. Deploying the radiators allows cooling to occur from both sides of each radiator panel increasing the heat dissipation. The two aft radiator panels (3 and 4) attached on each payload bay door are single-sided. While aft radiator panel 3 is permanently installed, the aft radiator panel 4 is a kit and can be added or removed depending on mission cooling requirements. Radiators are deployed and stowed using the switch on Panel 7.
- **Flash Evaporator System:** The FES rejects heat loads from Freon coolant loop 1 by evaporating supply water in a vacuum. The FES is used during ascent, and it supplements the radiators on orbit if required. It also rejects heat loads during deorbit and entry. The evaporators are cylindrical shells with dual water spray nozzles at one end and a steam exhaust duct at the other end. The shell is composed of two separate finned packages, one for each Freon loop. The hot Freon from the coolant loops flows around the finned shell, and water is sprayed onto the inner surface of the shell by water nozzles from either evaporator. The water vaporizes, cooling the Freon coolant loops. Controllers modulate the water spray in the evaporator to keep the Freon coolant loops' evaporator outlet temperature below 60° F.

7.5 Supply and Wastewater Systems

The supply water system provides water for flash evaporator system cooling, crew consumption, and hygiene. The supply water system stores water generated by the fuel cells, and the wastewater system stores waste from the crew cabin humidity separator and from the flight crew. The system also has the capability to dump supply and wastewater overboard.

7.6 ECLSS Operations

During Normal flight operations the PCS is preset to 760 Torr upon crew ingress of the vehicle. During the T-5:00 Launch hold the environmental systems including Oxygen, Nitrogen, and water loop are set to the open position. During ascent the ATCS including the Freon loops, air, and water heat exchangers are set to open just after SRB separation and reset to GPC just before completion of the OMS burn. Radiators are deployed after completion of the OMS burn to assist with heat dissipation. Supply and wastewater systems are active throughout flight operations.

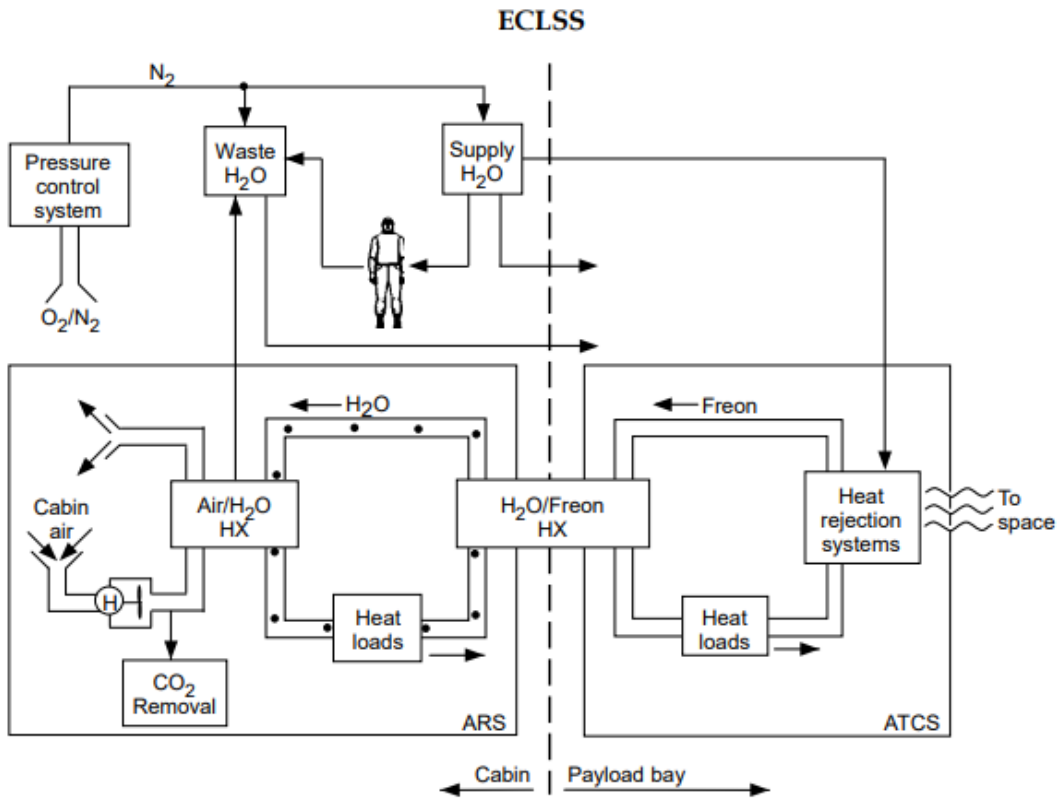

Environmental Control and Life Support System Overview

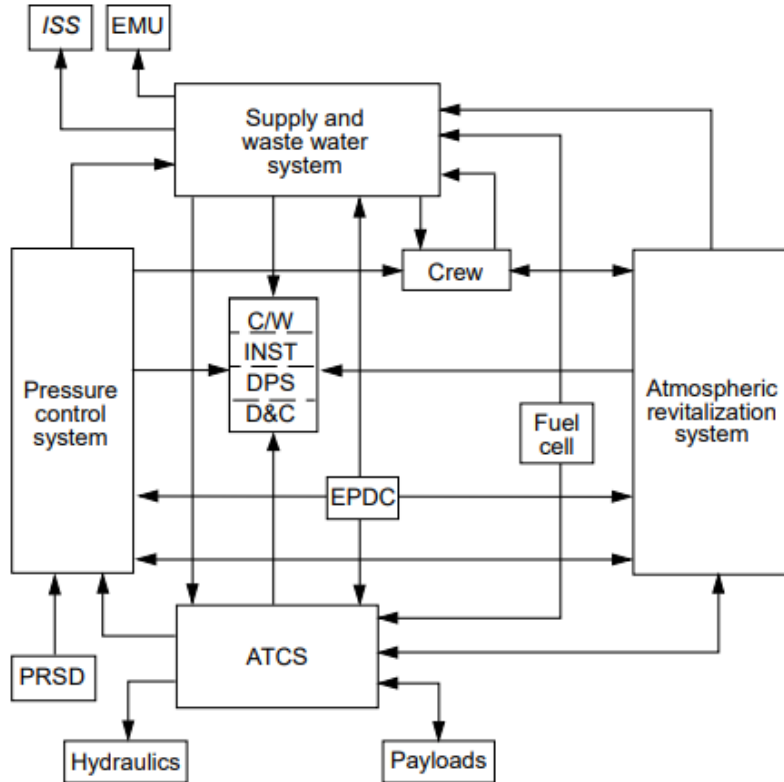

Environmental Control and Life Support System Interfaces

7.7 ECLSS Caution and Warning System

ECLSS ANNUNCIATOR PANEL SCHEMATIC

O ₂ PRESS	H ₂ PRESS	SMOKE / FIRE	LANDING SYS	FUEL CELL TEMP
CABIN ATM	H ₂ /O ₂ HEATER TEMP	MAIN BUS VOLTAGE	AC VOLTAGE	AC O/U LOAD
FREON LOOP	AV BAY/CABIN AIR	IMU	RCS FWD	RCS JET
H ₂ O LOOP	SRB LEFT	MAIN ENGINE LEFT	RCS LEFT	RCS RIGHT
PAYLOAD BAY	SRB RIGHT	MAIN ENGINE CNTR	OMS LEFT	OMS RIGHT
PAYLOAD	GPC	MAIN ENGINE RIGHT	NAV SYSTEM	OMS TVC
ALARM	APU TEMP	APU SPEED	H ₂ O SPRAY BOILER	HYD PRESS

The Orbiter ECLSS caution and warning system is located on the Flight Engineer Data Panel in the annunciator matrix. ECLSS alerts can be caution (yellow) or warning (red). Caution lights may indicate a system value out of nominal but still within accepted parameters. Warning lights indicate a malfunction in the system that must be repaired. These alerts can be used in conjunction with notifications listed in the information box (Blue Box) on the Basic Control Data Panel (Pilot's Panel) to complete emergency procedures.

AV BAY/CABIN AIR: Indicates out of limits condition on cabin fan DP, AV Bay (1, 2, or 3) air out temp, or cabin heat exchanger air temp.

CABIN ATM: Indicates either cabin pressure, PPO₂, O₂ flow rate, or N₂ flow rate out of limits.

FREON LOOP: Indicates a low Freon loop (1 or 2) flow rate or a temperature out of limits.

H₂O LOOP: Indicates an out of limits condition on H₂O loop 1 or 2 pump out pressure.

ECLSS Summary

Notes:

- The functions of the ECLSS are to maintain the orbiter's thermal stability, provide a pressurized, habitable environment for the crew and onboard avionics, and store water and liquid waste.
- The four components of the ECLSS are the pressure control, atmospheric revitalization, active thermal control, and supply and wastewater systems.
- The pressure control system pressurizes the crew cabin at 14.7 psia (760 Torr) and pressurizes the supply and waste water tanks.
- The atmospheric revitalization system circulates air through the crew compartment to control relative humidity between 30 and 65 percent, maintain carbon dioxide and carbon monoxide at non-toxic levels, provide air filtration, control temperature and ventilation in the crew compartment, and provide avionics cooling. The water loop provides cooling for the crew and avionics.
- The active thermal control system provides orbiter heat rejection during all phases of the mission.
- The supply water system stores water generated by the fuel cells. The supply water is used for flash evaporator system cooling, crew consumption, and hygiene.
- The wastewater system stores waste from the crew cabin humidity separator and from the crew.
- Panels that control the major portion of ECLSS functions are panels 5 and 7.

Rules of Thumb:

Note: Numbers presented here are for typical orbit power and heat loads and may vary significantly, depending on attitude and power loading.

- Supply water tanks fill at about 6.5 percent per hour, depending on fuel cell load.
- Assuming no concurrent fuel cell water replenishment, supply water tanks empty at about 90 percent per hour for a water dump.
- A single LiOH canister is usable for about 48 man-hours.

8 GUIDANCE, NAVIGATION, and CONTROL (GNC)

8.1 Introduction

Guidance is the computation of corrective actions to change from the navigation-determined vehicle state to a required vehicle state. The required state depends on particular mission requirements, which usually specify a required present state (e.g., a particular orbit) or an objective (e.g., rendezvous at a point in space) from which the present required state can be computed.

Navigation is the determination of the state of motion of the vehicle, i.e., position, velocity, and attitude. This state is determined with reference to some mission-dependent coordinates suitable for defining the motion of the vehicle.

Control is the application of corrective maneuvers to obtain the changes commanded by guidance. Flight control for the orbiter converts guidance computations into effector commands to point and translate the vehicle. Control software frequently uses navigation data to determine the effectors used and the appropriate system control gains.

The basic function of the orbiter navigation system is to maintain an accurate estimate of the inertial position and velocity of the vehicle, called its state vector, with respect to time. The navigation system tracks the orbiter's position and velocity with six parameters (X, Y, Z, Vx, Vy, Vz) that define the state vector. A time tag is also associated with this state vector. The X, Y, Z components are the orbiter's position in space measured in feet from the center of the Earth. The velocity components are measured in feet per second. The time at which the state vector is applicable is based on Greenwich mean time (GMT).

The navigation system uses the standard equations of motion along with the information received from the inertial measurement units, the navigation sensors, and the software models of the forces acting on the orbiter (gravity, drag, vents, etc.) to predict the components of the state vector at each time value.

8.2 GNC Components

The Guidance and Navigation Control System consists of multiple components that work together to provide maneuverability to the orbiter. These components include:

8.2.1 Inertial Measurement Units: There are three IMUs on the orbiter. Each contains three accelerometers and two two-axis gyros mounted on an inertially stabilized four gimbal platform. The IMUs provide inertial attitude and velocity data to the GNC software functions. Navigation software uses the processed IMU velocity and attitude data to propagate the orbiter state vector. Guidance uses the attitude data, along with the state vector from the navigation software, to develop steering

commands for flight control. Flight control uses the IMU attitude data to convert the steering commands into control surface, engine gimbal (thrust vector control), and RCS jet fire commands.

The IMU consists of a platform isolated from vehicle rotations by four gimbals. Since the platform does not rotate with the vehicle, its orientation remains fixed, or inertial, in space.

8.2.2 Star Trackers: A star tracker is an optical device that measures the positions of certain stars using a camera or solid-state sensors. The star tracker may be used to determine the orientation (or attitude) of the spacecraft with respect to the stars. The star tracker system consists of the negative Y axis tracker and the negative Z axis tracker. They are located just forward and to the left of the commander's station in a well outside the crew compartment, an extension of the navigation base on which the IMUs are mounted.

The star trackers are used to align the IMUs onboard the orbiter, as well as to track targets and provide line-of-sight vectors for rendezvous calculations. The GPC memory contains inertial information for up to 100 stars. The stars are chosen for their brightness and their ability to provide complete sky coverage.

Each star tracker has a door to protect it during ascent and entry. The doors are opened on orbit to permit use of the star trackers. The star tracker can be controlled by the switch on Panel 2 and the doors can be controlled by the switches on Panel 8 (touch screen).

The basic operational process for a star tracker starts with an image captured by the sensor while recording the direction to the star from the spacecraft. The image is then analyzed and compared to a star catalogue (a highly accurate database of known star positions). When a match is found, that information combined with the current spacecraft orientation from on-board sensors, determine the direction the spacecraft is pointing. This data is then sent to the spacecraft attitude control system to update the spacecraft's orientation. This process is constantly repeated to guarantee a high degree of certainty about the spacecraft's positioning.

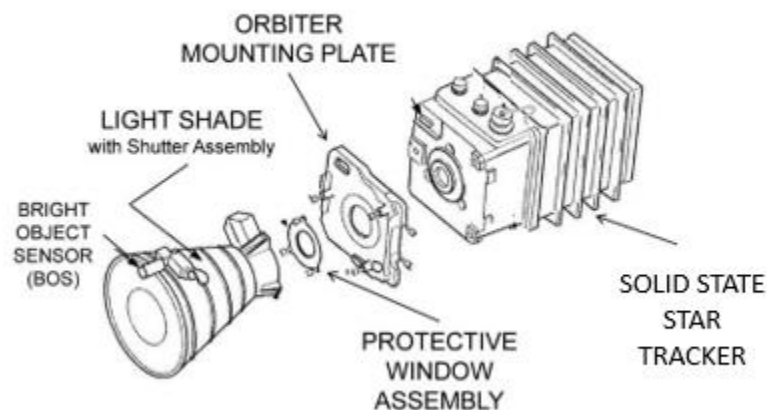

STAR TRACKER

The components that make up a basic star tracker are:

- **Stray Light Shield:** This conical shaped shield, similar to a lens hood on a camera, is used to prevent random (or stray) light from entering the optical system. The stray light shield is located on the end of the optical system. This shielding is needed as star trackers are designed to locate and track dim stars and any excess light will induce orientation errors or damage the star tracker.
- **Optical System:** This system is a set of lenses that bring the image of the star field into proper focus and a set of filters that detect the different wavelengths of light entering the system. Certain stars can be identified by their unique wavelength signature. Additionally, the filters can remove any wavelength that could cause heat buildup.
- **Image Definition Device:** This device restricts the size of the image that gets to the detector as a full-size image is rarely necessary for accurate attitude determination.
- **Detector:** The detector takes the optical image and turns it into an electrical signal. Generally, there are two types of detectors, an analog image dissector tube (IDT) and a charge-coupled solid-state device (CCD). The IDT will create an electrical signal for the system, while a CCD will convert the image directly into digital pixels.
- **Electronics:** The electronics for the sensor amplify and filter noise from the detector signal. The signal is then passed to the onboard computer for attitude analysis.

8.2.3 Global Positioning System: GPS is a space-based radio positioning navigation system that provides three-dimensional position, velocity, and time information to suitably equipped users anywhere on or near the surface of the Earth. The GPS group consists of 27 satellites, including 3 active on-orbit spares. The satellites travel in 10,980 n. mi. orbits at velocities of 14,500 km/hr. for periods of 12 hours. These satellites are in six planes, each at an inclination of 55° with respect to the equator.

The NAVSTAR constellation of satellites and their support equipment are financed by the DoD, but their navigation signals are available free of charge to anyone. The NAVSTAR satellite constellation control center facility is located at Falcon Air Force Base in Colorado Springs, CO.

The way a GPS receiver interacts with the NAVSTAR satellites to determine position and velocity is straightforward. Each GPS satellite repeatedly transmits a specific sequence of codes. The receiver knows each satellite's code pattern, as well as what time a satellite is supposed to transmit specific parts of the code. After identifying a specific satellite (via code matching techniques), the GPS receiver compares the time at which it received the specific part of the code to the time at which the satellite was supposed to have sent it. This time delta directly corresponds to how far the receiver is from the given satellite. For a receiver to determine exactly where it is near the Earth, it must make at least three such measurements from three different satellites. For the receiver to accurately measure the time delta, it must have an extremely accurate internal clock. Most receivers do not have an atomic clock; therefore, a fourth measurement is taken from another satellite to help the receiver determine its clock bias and, thus, determine an accurate state vector.

The orbiter has three GPS receivers that operate redundantly. Each receiver is equipped with two antennas: one on the orbiter's lower forward fuselage and one on the upper forward fuselage. The

antennas are covered with thermal protection system tiles. The GPS system can be controlled via the GPS 1, 2, and 3 switches located on Panel 5.

8.2.4 Flight Control System Hardware: The flight control system (FCS) ascent and entry hardware provides manual guidance commands to GNC software and responds to effector commands from GNC software in order to effect vehicle and trajectory control.

The following hardware includes sensors responsible for flight control data and response to manual and software commands:

- **Rate Gyro Assembly:** The orbiter has four RGAs. Each RGA contains three identical single-degree-of-freedom rate gyros so that each gyro senses rotation about one of the vehicle axes. These rates are the primary feedback to the FCS during ascent, entry, insertion, and deorbit. The FCS must have good rate feedback in all three axes to maintain control. RGAs 1 and 4 prevent the loss of more than one rate gyro assembly if main bus power is lost. The RGAs are turned off during orbit to conserve power. The RGAs can be controlled via the RATE GYRO ASSEMBLY 1, 2-3, and 4 switches on Panel 1.
- **Rotational/Translational Hand Controller:** On orbit, the commander's and pilot's RTHCs (Joysticks) may be used to gimbal the OMS engines and command RCS jets. In addition, the commander's RTHC may be used to command RCS jets during the early portion of entry, as well as to command the orbiter aerosurfaces during the latter portion of entry.
- **Thrust Controller:** On orbit, the thrust controller (Throttle) located on the left side of the commander's station, can be used to manually adjust the orbital status by activating the OMS.
- **Speed Brake Controller:** During entry and landing, the pilot's SBC may be used to control aerodynamic drag (hence airspeed) by opening or closing the speed brake. The speed brake controller switch is located on Panel 6.
- **Digital Auto Pilot:** The digital autopilot (DAP) is the heart of flight control software. It is composed of several software modules that interpret maneuver requests, compare them to what the vehicle is doing, and generate commands for the appropriate effectors.

The DAP controls the orbiter in response to automatic or manual commands during insertion and on orbit. The effectors used to produce control forces on the orbiter are the two OMS engines and the primary RCS jets. The vernier RCS jets are also available on orbit for attitude control. The forward and aft RCS jets also provide attitude control and three-axis translation during external tank separation, insertion, and on-orbit maneuvers, as well as roll control for a single-OMS-engine operation. The OMS provides propulsive control for orbit insertion, orbit circularization, transfer, and rendezvous. The DAP can be configured using the DIGITAL AUTO PILOT switch on Panel 2.

8.3 GNC Operations

Ascent: The terminal count phase extends from T-5 minutes through SRB ignition. During this timeframe, the GNC OPS 1 software is loaded into the GPCs via the keypad located between the commander and pilot stations and is verified by the mission control team.

First-stage guidance is active from SRB ignition through SRB separation command. In this stage, guidance uses a preflight planned ("canned") table of roll, pitch, and yaw attitudes referenced to relative velocity. In addition to sending commands to flight control to obtain proper attitudes, the guidance software also sends commands to the MPS throttle per a preflight defined throttle schedule. Steering of the vehicle during first stage is accomplished by gimbaling primarily the SRB nozzles. First-stage guidance also attempts to relieve vehicle aerodynamic loads based on sensed accelerations.

During first stage, no GNC-related crew actions are planned unless a failure occurs. Following launch, the crew uses the Ascent Flip Book checklist for general procedures.

Second-stage ascent begins at SRB separation and extends through MECO and external tank separation. During second stage, the crew monitors the onboard systems to ensure that the major GNC events occur correctly. The predicted time of MECO (TMECO) is calculated by both PASS and BFS computers.

Note: A discrepancy between PASS and BFS may indicate a guidance error, requiring the crew to take action.

At MECO, the DAP becomes active. Initially it sends attitude hold commands. External tank separation is automatically commanded about 20 seconds after MECO. The DAP immediately sets commands to fire the orbiter -Z RCS jets resulting in the orbiter translating in the -Z direction (away from the external tank). When -4 fps delta velocity is reached, the fire commands are removed.

Orbit Insertion: During the orbit insertion phase, the guidance software is used to target the OMS burn. Insertion flight control is accomplished using the DAP. The auto pilot uses commands from guidance for automatic maneuvers to a burn attitude using the RCS jets. During the OMS burn, it uses the OMS engines and RCS jets as required. After the completion of the OMS burn, the DAP is set to manual to allow the crew to make rotational corrections to the vehicle attitude. On nominal flight plans, this action will set the vehicle to a prograde attitude.

Deorbit: The deorbit phase of the mission includes the deorbit burn preparations (auto Retrograde), the loading of burn targets, the execution and monitoring of the burn, post-burn reconfiguration (auto Prograde), and a coast mode until about 40 kilometers above the Earth's surface.

Approach/Landing: Landing guidance software commences when the vehicle is approximately 35 kilometers in altitude, and near the proper airspeed with a flight path angle for the outer glide slope of 20°. The guidance software sends commands to keep the vehicle tracking the runway centerline and on the steep glide slope until a flare maneuver is performed to put the orbiter on a shallow glide slope (1.5°) for final approach. Flight path information is located on the Horizontal Situation Indicator (HSI) visible in the left MFD on the main orbiter screen.

8.4 GNC Caution and Warning System

GNC ANNUNCIATOR PANEL SCHEMATIC

O2 PRESS	H ₂ PRESS	SMOKE / FIRE	LANDING SYS	FUEL CELL TEMP
CABIN ATM	H ₂ /O ₂ HEATER TEMP	MAIN BUS VOLTAGE	AC VOLTAGE	AC O/U LOAD
FREON LOOP	AV BAY/CABIN AIR	IMU	RCS FWD	RCS JET
H ₂ O LOOP	SRB LEFT	MAIN ENGINE LEFT	RCS LEFT	RCS RIGHT
PAYLOAD BAY	SRB RIGHT	MAIN ENGINE CNTR	OMS LEFT	OMS RIGHT
PAYLOAD	GPC	MAIN ENGINE RIGHT	NAV SYSTEM	OMS TVC
ALARM	APU TEMP	APU SPEED	H ₂ O SPRAY BOILER	HYD PRESS

The Orbiter GNC caution and warning system is located on the Flight Engineer Data Panel in the annunciator matrix. GNC alerts can be caution (yellow) or warning (red). Caution lights may indicate a system value out of nominal but still within accepted parameters. Warning lights indicate a malfunction in the system that must be repaired. These alerts can be used in conjunction with notifications listed in the information box (Blue Box) on the Basic Control Data Panel (Pilot's Panel) to complete emergency procedures.

IMU: Indicates detection of an inertial measurement unit (IMU) failure or dilemma.

NAV SYSTEM: Indicates a failure or parameter out-of-limits error in the Navigation System components. These components may include: the Star Tracker, IMU, GPS, or Digital Auto Pilot. A NAV SYSTEM error may also indicate a malfunction in the GPC.

OMS TVC: Indicates detection of an OMS pitch or yaw gimbal failure. An OMS TVC failure may indicate a failure in the GPC. OMS TVC failure may precipitate a LEFT or RIGHT OMS failure.

GNC Summary

Notes:

- GNC systems determine the current state of motion of the vehicle, compute actions to change its state of motion, and apply corrective maneuvers to achieve the change.
- GNC elements are navigation and flight control system hardware and digital autopilot software.
- A bad orbiter navigation state can degrade flight control since navigation data are used to set control gains and choose control effectors.
- Navigation hardware includes: (1) IMUs, which sense vehicle orientation and accelerations; (2) star trackers, which sense vehicle line of sight vectors; (3) GPS, which senses satellite ranging signals to determine orbiter position and velocity.
- The flight control system hardware includes four accelerometer assemblies, four orbiter rate gyro assemblies, four SRB rate gyro assemblies, and rotational and translational hand controllers (Joystick), thrust controller, speed brake controller, and ascent thrust vector control.
- DAP software interprets maneuver requests, compares them to what the vehicle is doing, and generates commands for the appropriate effectors.
- Primary GNC-related switches and pushbuttons are located on panels 1, 2, 5, 7, and 8.

9 MAIN PROPULSION SYSTEM (MPS)

9.1 Introduction

The space shuttle main engines (SSMEs), assisted by two solid rocket motors during the initial phases of the ascent trajectory, provide vehicle acceleration from lift-off to main engine cutoff (MECO) at a predetermined velocity.

The MPS has critical interfaces with the orbiter hydraulic system, electrical power system, master events controller, and data processing system. The hydraulic system supplies hydraulic pressure to operate the main engine valves and gimbal actuators. The electrical power system furnishes AC power to operate the main engine controllers and DC power to operate the valves and transducers in the propellant management and helium systems. The master events controller initiates firings of pyrotechnic devices to separate the SRBs from the external tank and the external tank from the orbiter. The data processing system controls most of the MPS functions during ascent and entry.

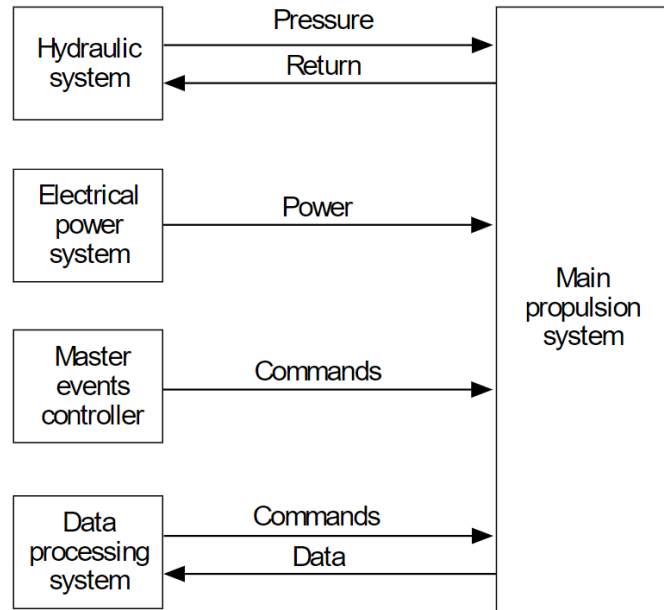

CRITICAL INTERFACES WITH THE MAIN PROPULSION SYSTEM

The MPS has three SSMEs, three SSME controllers, the ET, the orbiter MPS propellant management system and helium subsystem, ascent thrust vector control units, and SSME hydraulic TVC servo actuators. Most of the MPS is located in the aft fuselage beneath the vertical stabilizer.

9.2 MPS Components

9.2.1 Space Shuttle Main Engine: The three Space Shuttle Main Engines (SSMEs) are reusable, high-performance, liquid propellant rocket engines with variable thrust.

The SSME is a staged combustion engine that uses a mixture of gaseous hydrogen and liquid oxygen as fuel. The notable feature of this type of engine is the "preburning" process where most of the fuel and a small part of the oxidizer are burned in a preburner with a highly fuel-rich mixture. This preburned fuel-rich hot gas drives the turbopump turbine before being injected into the main combustion chamber (MCC) alongside the remaining oxidizer and the coolant fuel for the final burn.

The SSME can produce a thrust of 2,094,222.7 N [newton] (equivalent to 470,800 lbf) in vacuum and 1,675,200.3 N (376,600 lbf) at sea level. Its thrust can be adjusted between 67% (1,406,082.9 N; 316,100

lbf) and 109% (2,281,492.9 N; 512,900 lbf) in increments of about 1% (20,907 N; 4,700 lbf). Throttling is managed by adjusting the output of the preburners, which alters the speed of the high-pressure turbopumps, and consequently, the propellant mass flow rates.

All three main engines receive the same throttle command at the same time. Normally, these come automatically from the orbiter general-purpose computers (GPCs) through the engine controllers. During certain contingency situations, engine throttling may be controlled manually through the pilot's thrust controller. SSME throttling reduces vehicle loads during maximum aerodynamic pressure and limits

Space Shuttle Main Engine

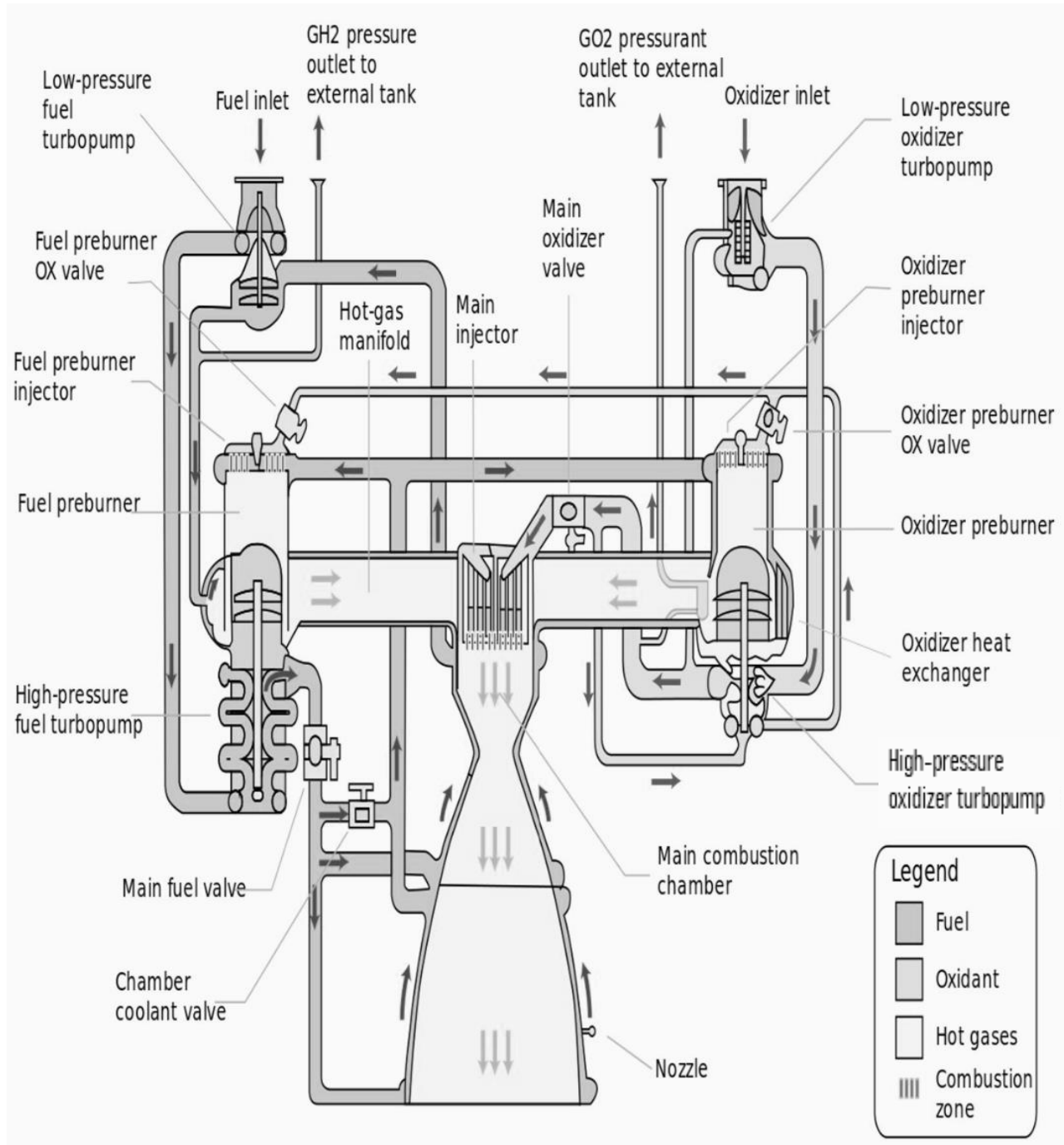

vehicle acceleration to a maximum of 3 g's during ascent. Hydraulically powered gimbal actuators allow each engine to be gimballed in the pitch and yaw axes for thrust vector control.

9.2.2 SSME Components: The SSME major components are the fuel and oxidizer turbopumps, preburners, a hot gas manifold, main combustion chamber, nozzle, oxidizer heat exchanger, and propellant valves.

- **Turbo Pumps:** The low-pressure fuel turbopump is an axial flow pump driven by a two-stage axial flow turbine powered by gaseous hydrogen. It boosts liquid hydrogen pressure and supplies the high-pressure fuel turbopump. The high-pressure fuel turbopump, a three-stage centrifugal pump driven by a two-stage, hot-gas turbine, boosts liquid hydrogen pressure and operates at approximately 35,360 rpm. The discharge flow from the high-pressure turbopump is routed through the main fuel valve. The low and high-pressure oxidizer pumps operate in a similar manner.
- **Hot Gas Manifold:** The hot-gas manifold is the structural backbone of the engine. It supports the two preburners, the high-pressure turbopumps, and the main combustion chamber. Hot gas generated by the preburners, after driving the high-pressure turbopumps, passes through the hot-gas manifold on the way to the main combustion chamber.
- **Pre Burners:** The oxidizer and fuel preburners are welded to the hot-gas manifold. Liquid hydrogen and liquid oxygen from the high-pressure turbopumps enter the preburners and are mixed so that efficient combustion occurs. The preburners produce the fuel-rich hot gas that passes through the turbines to generate the power to operate the high-pressure turbopumps.
- **Main Combustion Chamber:** Each engine's main combustion chamber receives fuel-rich hot gas from the fuel and oxidizer preburners. The high-pressure oxidizer turbopump supplies liquid oxygen to the combustion chamber where it is mixed with fuel-rich gas by the main injector. The nozzle assembly is bolted to the main combustion chamber. The nozzle is 113 inches long, with an exit plane of 94 inches.
- **Oxidizer Heat Exchanger:** The oxidizer heat exchanger converts liquid oxygen to gaseous oxygen for tank pressurization and pogo suppression. The heat exchanger receives its liquid oxygen from the high-pressure oxidizer turbopump discharge flow.
- **Propellant Valves:** Each engine has five propellant valves (oxidizer preburner oxidizer, fuel preburner oxidizer, main oxidizer, main fuel, and chamber coolant) that are hydraulically actuated and controlled by electrical signals from the engine controller.

9.2.3 Propellant Management System

(PMS): Liquid hydrogen and liquid oxygen pass from the ET to the PMS, which consists of manifolds, distribution lines, and valves. It also contains lines needed to transport gases from the engines to the external tank for pressurization. During prelaunch activities, this subsystem is used to load liquid oxygen and liquid hydrogen into the external tank. After MECO, the PMS is used to complete a liquid oxygen and liquid hydrogen dump and vacuum inerting. Two 17-inch-diameter Main Propulsion System propellant feedline manifolds are in the orbiter aft fuselage, one for liquid oxygen and one for liquid hydrogen. Each manifold interfaces with its respective line on the ET. Both manifolds interface with an 8-inch fill/drain line containing an inboard and outboard fill/drain valve in series. Inside the orbiter, the manifolds diverge into three 12-inch SSME feedlines, one for each engine.

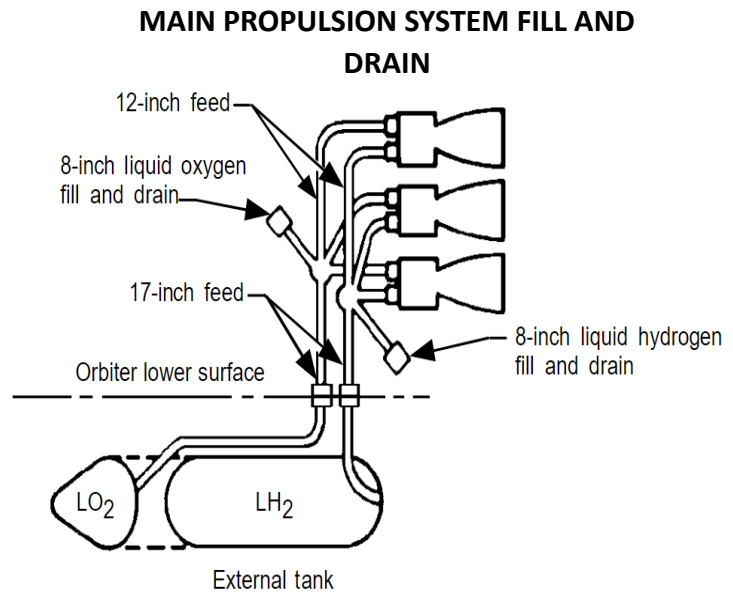

Two (outboard and inboard) 8-inch-diameter liquid oxygen and liquid hydrogen fill/drain valves are connected in series. They are used to load the external tank before launch to perform the post-MECO MPS propellant dump. The valves can be manually controlled by the H₂ and O₂ INBOARD and OUTBOARD switches on Panel 1.

9.2.4 Hydraulic System: The three orbiter hydraulic systems supply hydraulic pressure to each SSME to actuate the engine valves and to provide thrust vector control. The three hydraulic supply systems are distributed to the thrust vector control (TVC) valves. When the three valves are opened, hydraulic pressure is applied to the five hydraulically actuated engine valves (the main fuel valve, the main oxidizer valve, the fuel preburner oxidizer valve, the oxidizer preburner oxidizer valve, and the chamber coolant valve).

9.3 MPS Operations

Pre-Launch: During prelaunch, the pneumatic helium supply provides pressure to operate the liquid oxygen and hydrogen prevalues and outboard and inboard fill and drain valves. During the T-5:00 Launch Hold, the PNEUMATIC He ISOL valves 1, 2, and 3 are set to open. This procedure will not change the position of the helium isolation valves, which were already open, but it inhibits the launch processing system's control of valve position.

During prelaunch, liquid oxygen from ground support equipment is loaded through the ground support equipment liquid oxygen T-0 umbilical and passes through the liquid oxygen outboard fill and drain valve, the liquid oxygen inboard fill and drain valve, and the orbiter liquid oxygen feedline manifold. The

liquid oxygen exits the orbiter at the liquid oxygen feedline umbilical disconnect and enters the liquid oxygen tank in the external tank. Liquid Hydrogen is filled in a similar manner.

Engine Start: Beginning at the T- 5:00 Launch hold, a series of steps are taken to complete fueling and begin the engine start sequence:

- T-4:55 ET liquid Oxygen vents are closed.
- T-4:30 LOX and LH₂ filling top off is completed.
- T-4:00 Helium purge begins.
- T-3:30 Engine gimbal test begins, during which each gimbal actuator is operated through a canned profile of extensions and retractions.
- T-2:15 If all actuators function satisfactorily, the engines are gimbaled to a predefined position. The engines remain in this position until engine ignition.
- T-2:00 Liquid Hydrogen vents close.
- T-0:20 SRB gimbal test is initiated.
- T-0:07 The firing sequence begins.
- T-0:06 The GPCs issue the engine start command, and the main fuel valve in each engine opens. Between the opening of the main fuel valve and MECO, liquid hydrogen flows out of the external tank/orbiter liquid hydrogen disconnect valves into the liquid hydrogen feedline manifold. From this manifold, liquid hydrogen is distributed to the engines through the three engine liquid hydrogen feedlines. In each line, liquid hydrogen passes through the prevalues and enters the main engine at the inlet to the low-pressure fuel turbopump.
- T-0:04 the launch command is given. If all main engines are firing properly then the SRBs are auto ignited.

Ascent: Beginning at T minus 0, the SSME gimbal actuators, which were locked in their special pre-ignition position, are first commanded to their null positions for solid rocket booster start and then are allowed to operate as needed for thrust vector control.

Between lift-off and MECO, if the SSMEs perform nominally, all MPS sequencing and control functions are executed automatically by the GPCs. During this period, the flight crew monitors MPS performance and provides manual inputs in the event of MPS malfunctions.

Engines are normally powered at 104% but can be adjusted up to 109% if required for emergency situations. At T+0:44 the main engines are throttled back to 65% in preparation for passing through the region of maximum dynamic pressure (Max Q). At T+1:10 the engine power level is returned to 104%. At approximately T+2:05 the SRBs complete their burn and are jettisoned. This also begins the process of the OMS assisting the main engine burn. At T+8:00 the engines are throttled back in preparation for MECO. Main engine cutoff occurs at approximately T+8:55.

MECO: Normally, the GPCs command MECO once the vehicle has attained a specified velocity. The crew observes MECO through the illumination of the three red MAIN ENGINE STATUS lights on the basic control data panel (Pilot's panel). Once MECO has been confirmed at approximately 8 minutes 55 seconds MET, the GPCs execute the external tank separation sequence.

After external tank separation, approximately 1,700 pounds of propellant are still trapped in the SSMEs, and an additional 3,700 pounds of propellant remain trapped in the orbiter's MPS feedlines. This 5,400 pounds of propellant represents an overall center-of-gravity shift for the orbiter of approximately 7

inches. Non-nominal center-of-gravity locations can create major guidance problems during entry. The residual liquid oxygen, by far the heavier of the two propellants, poses the greatest impact on center-of-gravity travel.

During the approximately 2 minutes after MECO and before the start of the OMS burn, all excess propellant must be dumped overboard. The H₂ and O₂ INBOARD and OUTBOARD valves are set to open using the switches on Panel 1, allowing the propellant to escape.

Post OMS burn, the MPS is essentially unpowered. During deorbit prep the Pneumatic helium valves are opened and used for entry purge and manifold repressurization.

9.4 MPS Caution and Warning

MPS ANNUNCIATOR PANEL SCHEMATIC

O2 PRESS	H ₂ PRESS	SMOKE / FIRE	LANDING SYS	FUEL CELL TEMP
CABIN ATM	H ₂ /O ₂ HEATER TEMP	MAIN BUS VOLTAGE	AC VOLTAGE	AC O/U LOAD
FREON LOOP	AV BAY/CABIN AIR	IMU	RCS FWD	RCS JET
H ₂ O LOOP	SRB LEFT	MAIN ENGINE LEFT	RCS LEFT	RCS RIGHT
PAYLOAD BAY	SRB RIGHT	MAIN ENGINE CNTR	OMS LEFT	OMS RIGHT
PAYLOAD	GPC	MAIN ENGINE RIGHT	NAV SYSTEM	OMS TVC
ALARM	APU TEMP	APU SPEED	H ₂ O SPRAY BOILER	HYD PRESS

The Orbiter MPS caution and warning system is located on the Flight Engineer Data Panel in the annunciator matrix. MPS alerts can be caution (yellow) or warning (red). Caution lights may indicate a system value out of nominal but still within accepted parameters. Warning lights indicate a malfunction in the system that must be repaired. These alerts can be used in conjunction with notifications listed in the information box (Blue Box) on the Basic Control Data Panel (Pilot's Panel) to complete emergency procedures.

MAIN ENGINE CNTR: Indicates detection of a center main engine pod fuel tank ullage pressure out of limits, or an engine abnormal (main engine fail to ignite, or early shutdown) condition.

MAIN ENGINE LEFT: Indicates detection of a left main engine pod fuel tank ullage pressure out of limits, or an engine abnormal (main engine fail to ignite, or early shutdown) condition.

MAIN ENGINE RIGHT: Indicates detection of a right main engine pod fuel tank ullage pressure out of limits, or an engine abnormal (main engine fail to ignite, or early shutdown) condition.

SRB LEFT: Indicates detection of a left Solid Rocket Booster engine abnormal status (fail to ignite, or early shutdown) condition.

SRB RIGHT: Indicates detection of a right Solid Rocket Booster engine abnormal status (fail to ignite, or early shutdown) condition.

MPS Summary

Notes:

- The main engines, assisted by two solid rocket motors during the initial phases of the ascent trajectory, provide the vehicle acceleration from lift-off to MECO at a predetermined velocity.
- Most of the MPS is located at the aft end of the orbiter beneath the vertical stabilizer.
- The MPS consists of three SSMEs and controllers, the external tank, propellant management and helium systems, ascent thrust vector control units, and hydraulic servo actuators.
- The SSMEs are reusable, high-performance engines that use liquid hydrogen for fuel and cooling and liquid oxygen as an oxidizer.
- The SSMEs can be throttled 65 to 109 percent in 1 percent increments.
- Major SSME components are fuel and oxidizer turbopumps, preburners, a hot gas manifold, main combustion chamber, nozzle, oxidizer heat exchanger, and propellant valves.
- The propellant management system consists of manifolds, distribution lines, and valves that transport propellant from the external tank to the three main engines for combustion, and gases from the engines to the external tank for pressurization.
- The three orbiter hydraulic systems supply hydraulic pressure to the MPS to actuate engine valves and provide engine gimbaling for thrust vector control.
- MPS controls are located primarily on panels 1, 3, and 8.

Rules of Thumb:

- Direct insertion MECO is usually close to 8 minutes 55 seconds MET.
- SRBs will usually burn for approximately 2 minutes.
- Main engine and SRB status lights will display red to indicate the engine is off.
- To manually shut down an engine, use the main engine pushbutton on panel 3.

10 MECHANICAL SYSTEMS

10.1 Introduction

The orbiter's mechanical systems are those components that must be deployed, stowed, opened, or closed. An electrical or hydraulic actuator physically moves each of these components.

The mechanical systems include the active vent system, external tank (ET) umbilical doors, payload bay doors, deployable radiator system, Ku antenna, and the landing and deceleration system.

Actuators: The orbiter's electromechanical actuators contain two three-phase alternating current (AC) motors. The AC motors are reversible so that mechanisms may be driven in both directions (open or closed, stowed or deployed, latched or released).

10.2 Mechanical Systems Components

10.2.1 Active Vent System: The active vent system (AVS) equalizes the orbiter's unpressurized compartments to the ambient environment as the orbiter travels from the pressurized atmosphere of Earth to the vacuum of space.

Each vent door has a pressure seal and a thermal seal and is driven inward by its associated electromechanical actuator. The vent openings are sized according to the volume to be vented. During countdown, the vent doors are in their purge positions until T-28 seconds, when the OPEN sequence is automatically called by the redundant set launch sequencer (RSLs). The vent doors are commanded open in a staggered sequence at approximately 2.5-second intervals. The vent doors remain open during ascent, orbital insertion, and all on-orbit phases. During entry preparation, the vent doors are closed. Nominally, the AVS operates automatically.

10.2.2 External Tank Umbilical Doors: Electrical and fuel umbilicals between the external tank and the orbiter enter the shuttle through two aft umbilical openings located on the underside of the orbiter. These umbilical cavities contain the orbiter/ET attachment points and the fuel and electrical disconnects. The left cavity contains the liquid hydrogen umbilical, and the right cavity contains the liquid oxygen umbilical.

Each umbilical cavity has an associated ET door. During ascent, this door is open to allow the umbilical connections between the orbiter and the ET. After the ET separates from the orbiter, the two aft umbilical openings are exposed. The ET doors are closed to cover these exposed areas and to shield them from entry heat. The ET doors are closed post OMS burn after MPS vacuum inerting.

10.2.3 Payload Bay Door System: The payload bay doors provide an opening for payload deployment from and retrieval into the payload bay. The doors provide structural support for the orbiter midbody, and they house the environmental control and life support system (ECLSS) radiators that transfer heat from the vehicle to space.

There are two doors, port and starboard. Each door consists of five segments interconnected by expansion joints. The doors are approximately 60 feet long with a combined area of 1,600 square feet. They are held closed by a total of 32 latches, 16 centerline latches that secure the doors to each other on the centerline and 8 forward and 8 aft bulkhead latches that secure the doors on the bulkheads.

Each of the payload bay doors is driven open or closed by a single electromechanical actuator with two three-phase AC motors per drive unit. The doors can be opened and closed via the payload bay switches located on Panel 7. The payload bay doors status can be viewed during the open or close procedure on the basic control data panel.

10.2.4 Landing and Deceleration System: The orbiter, unlike previous space vehicles, lands on a runway using a conventional type of landing system. Once the orbiter touches down, the crew deploys the drag chute, begins braking, and starts nose wheel steering operations.

The orbiter drag chute improves the orbiter's deceleration and eases the loads on the landing gear and brakes. The chute is a type known as a drogue which is designed for deployment from a rapidly moving object. The chute can be operated via the DROGUE CHUTE switch on Panel 6.

Braking is accomplished by a sophisticated system that uses electrohydraulic disk brakes with an anti-skid system. Before braking can occur, the hydraulic fluid must be warmed by hydraulic brake heaters. These heaters are auto activated by the GPCs at approximately 25K altitude. Only the two main gear sets have braking capability, and each can be operated separately via the wheel brake push buttons on the pilot's macro pad.

After touchdown, primary steering is accomplished using the joystick third axis (Rudder). Axis two should not be used after touchdown as this will raise the wings, partially lifting the vehicle. Secondary steering can also be used by applying variable pressure to the brakes, the crew can steer the vehicle by a method called differential braking.

The orbiter landing gear system is a tricycle configuration consisting of a nose landing gear and a left and right main landing gear. The nose landing gear has two doors, and each main gear has one door. When the crew commands gear deployment, the doors open automatically as the gear is dropped. The landing gear is deployed by first arming the landing system and then deploying the gear using the switches on Panel 6.

10.2.5 Radiators: Radiators act as a heat sink for the coolant loops. The radiator system consists of four radiator panels attached to the inside of each payload bay door. The two forward radiator panels on each payload bay door are deployable when the doors are opened on orbit. Radiators are deployed and stowed using the switch on Panel 7. (See subsection 7.4 for more information)

10.2.6 Ku-Band Antenna: The Ku-band deployed assembly provides the interface with the TDRS when there is a line of sight between the orbiter and TDRS. The assembly is mounted on the starboard sill longeron in the payload bay. The deployed assembly consists of a two-axis, gimbal-mounted, high gain antenna, an integral gyro assembly, and a radio frequency electronics box. The antenna can be deployed and stowed via the Ku-BAND switch on Panel 7. It normally takes 10 seconds to deploy or stow the assembly. The Ku-band antenna must be stowed before the radiator panels and the payload bay doors are closed in preparation for entry. If the assembly does not respond to normal stow operations, the KU ANTENNA DIRECT STOW switch on panel 8 (touch screen) can be used. Setting this

switch to ON bypasses the normal stow control sequences and causes the assembly to be driven inside the payload bay. DIRECT STOW merely positions the entire deployed assembly inside the payload bay and does not affect gimbal locking. If neither the normal stow nor the DIRECT STOW can position the assembly inside the payload bay, the assembly can be jettisoned. To jettison the assembly, the crew activates the PYRO KU ANT ARM and JETTISON switches on panel 8 (touch screen), which causes a guillotine to cut the cables to the deployed assembly and releases a clamp holding it to the pivot assembly. No ejective force is imparted; the assembly is merely cut loose, and the orbiter maneuvers away from it. The jettison operation takes about 4 seconds.

Mechanical Systems Summary

Summary:

- Orbiter mechanical systems are those components that must be deployed, stowed, opened, or closed. Each is physically moved by an electrical or hydraulic actuator.
- Power for actuator motors and limit switches is provided by motor control assemblies.
- The active vent system equalizes the unpressurized orbiter compartments and controls the orbiter’s internal environment by opening and closing vent doors in orbit or on the ground.
- The active vent system operates automatically.
- The external tank umbilical doors shield the two aft umbilical openings on the underside of the orbiter. The doors are closed post-OMS 1 burn after MPS vacuum inerting.
- The payload bay doors provide an opening for payload deployment from and retrieval into the payload bay.
- Two doors, port and starboard, are connected to the midfuselage. They are held closed by groups of centerline and bulkhead latches.

- Once the orbiter touches down, the crew deploys the drag chute, begins braking, and starts nose wheel steering operations.
- The radiator system consists of four radiator panels attached to the inside of each payload bay door.
- The Ku-band deployed assembly provides the interface with the TDRS when there is a line of sight between the orbiter and TDRS.

11 ORBITAL MANEUVERING SYSTEM (OMS)

11.1 Introduction

The Orbital Maneuvering System provides propulsion for the orbiter during multiple phases of flight. The OMS is used for orbit insertion, orbit circularization, orbit transfer, rendezvous, and deorbit. It may provide thrust above 70,000 feet altitude.

The OMS is housed in two independent pods, one on each side of the orbiter's aft fuselage. The pods, which also house the aft reaction control system (RCS), are referred to as the OMS/RCS pods. Each pod contains one OMS engine and the hardware needed to pressurize, store, and distribute the propellants to perform OMS engine burns. Normally, OMS maneuvers are done using both OMS engines together; however, a burn can be performed using only one OMS engine. For velocity changes less than 6 fps, RCS is used. For velocity changes greater than 6 fps, a single OMS burn is preferred, because engine lifetime concerns make it desirable to minimize engine starts. Two OMS engines are used for large velocity changes or for critical burns. Propellant from one pod can be fed to the engine in the other pod through crossfeed lines that connect the left and right OMS pods.

11.2 OMS Components

The Orbital Maneuvering System consists of multiple components that work together to provide propulsion. These components include:

11.2.1 OMS Engines: The OMS engines are designated left and right, descriptive of their location. The engines are located in gimbal mounts that allow the engine to pivot left and right (yaw) $\pm 7^\circ$ and up and down (pitch) $\pm 6^\circ$ under the control of two electromechanical actuators. This gimbal system provides for vehicle steering during OMS burns by controlling the direction of the engine thrust in pitch and yaw (thrust vector control) in response to commands from the digital autopilot or from the manual controls.

Each of the two OMS engines produces 6,087 pounds of thrust. For a typical orbiter weight, both engines together create an acceleration of approximately 2 ft/sec^2 or 0.06 g's . Using up a fully loaded tank, the OMS can provide a total velocity change of approximately 1,000 ft/sec. Orbital insertion burns and deorbit burns each typically require a velocity change of about 100– 500 ft/sec.

Each OMS engine is capable of 1,000 starts and 15 hours of cumulative firing. The minimum duration of an OMS engine firing is 2 seconds.

The OMS engines use monomethyl hydrazine as the fuel and nitrogen tetroxide as the oxidizer. These propellants are hypergolic, which means that they ignite when they come in contact with each other; therefore, no ignition device is needed.

The major elements of the OMS engine are the bipropellant valve assembly, the injector plate, the thrust chamber, and the nozzle.

- Bipropellant Valve Assembly:** Each OMS engine receives pressure-fed propellants at a bipropellant valve assembly, which regulates the flow of propellants to the engine to start and stop engine burns. The valve assembly consists of two fuel and two oxidizer valves in series. The name bipropellant valve means that each linked set of valves controls the flow of both propellants.

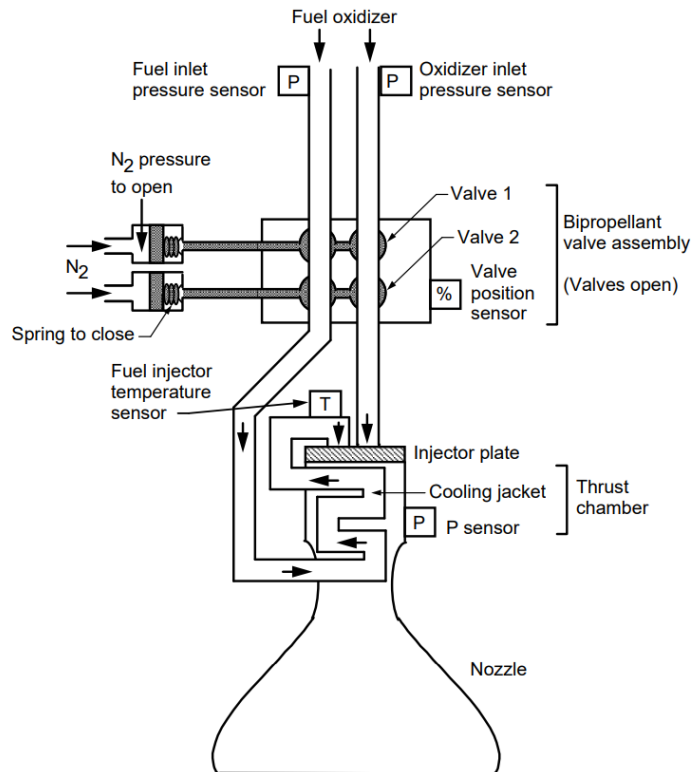

- Injector Plate:** After passing through the bipropellant valves, the oxidizer line runs directly to the engine injector plate. The fuel, however, is used to cool the engine, and so it is routed through a cooling jacket around the thrust chamber before it reaches the injector plate. Since the fuel injector temperature is the temperature of the fuel after it has passed through the chamber cooling jacket, it provides an indirect indication of the temperature of the thrust chamber walls. During engine operation, when the fuel is cooling the chamber, the fuel injector temperature should be approximately 218° F. The temperature limit for safe operation is 260° F.
- Thrust Chamber and Nozzle:** The fuel and oxidizer injector orifices are positioned so that the propellants will collide and atomize, causing the fuel and oxidizer to ignite because of hypergolic reaction. The resulting hot gas creates thrust as it exits the chamber and expands through the engine nozzle. The contoured nozzle extension is bolted to the aft flange of the combustion chamber.

11.2.2 Nitrogen System: Gaseous nitrogen is used to operate the engine control valves and to purge the fuel lines at the end of each burn. The valve control switches for the left and right OMS are located on panel 3. The nitrogen system consists of a storage tank, engine pressure isolation valve, regulator, relief valve, check valve, accumulator, engine purge valves, bipropellant solenoid control valves, and actuators that control the bipropellant ball valves.

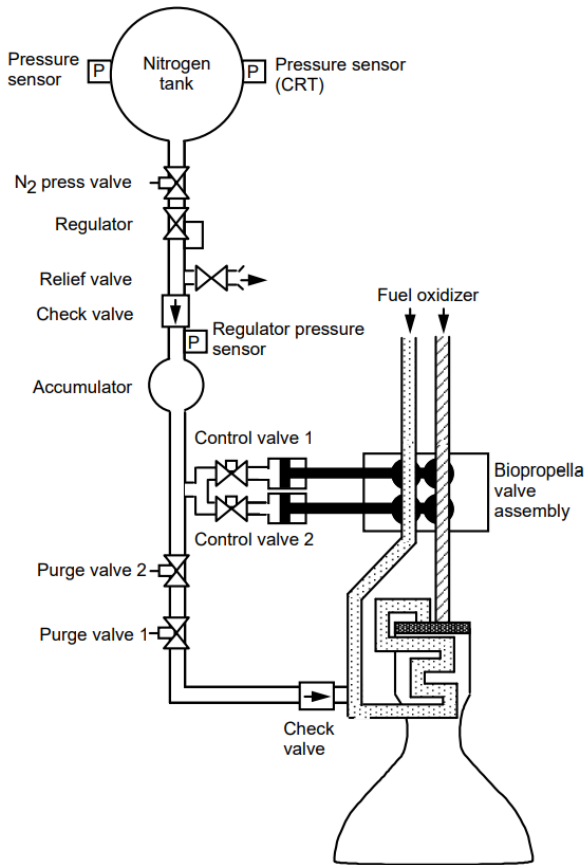

The regulator reduces nitrogen pressure from the tank, which can be as high as 3,000 psig, to a desired working pressure of 315 to 360 psig. A pressure relief valve downstream of the regulator limits the pressure to the engine bipropellant control valves and actuators if a regulator malfunctions. The relief valve opens between 450 and 500 psig and reseats at 400 psig minimum. The 19-cubic-inch gaseous nitrogen (GN2) accumulator downstream of the check valve and upstream of the bipropellant control valves provides enough pressure to operate the engine bipropellant control valves at least one time in the event of loss of pressure on the upstream side of the check valve. The nitrogen subsystem also purges the fuel lines following OMS burns. After an OMS burn, some fuel and oxidizer will be left in the engine inlet lines and will be subject to cold temperatures. The oxidizer does not present a problem, but the fuel could freeze. This situation is avoided by forcing nitrogen through

the fuel lines immediately after the engine shuts down. This purge is part of the automatic OMS burn sequence and takes about 2 seconds.

11.2.3 Helium System: Each OMS pod has a helium pressurization system consisting of a high-pressure gaseous helium storage tank, two helium pressure isolation valves, two dual pressure regulator assemblies, oxidizer vapor isolation valves, dual series-parallel check valve assemblies, and pressure relief valves. Switches for all OMS isolation valves are located on panel 8 (touch screen).

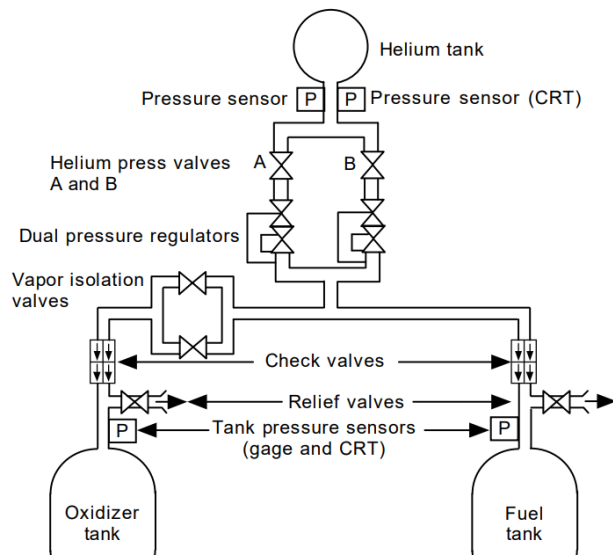

Oxidizer and fuel are supplied to each OMS engine by separate sets of propellant tanks. The OMS engine does not have fuel or oxidizer pumps; propellant flow must be maintained by keeping the tanks pressurized with helium. A single helium tank provides pressurization to both fuel and oxidizer tanks. One advantage to having a single helium tank in each pod is that it helps ensure that the two propellant tanks remain at the same pressure and thus avoids incorrect mixture ratios. The helium tank's operating pressure range is from 4,800 down to 390 psia.

11.2.4 Propellant Storage and Distribution: The OMS propellant storage and distribution system consists of one fuel tank and one oxidizer tank in each pod. It also contains propellant feed lines, crossfeed lines, isolation valves, and crossfeed valves. The OMS propellant in both pods enables the orbiter to perform a 1,000-foot-per-second velocity change with a 65,000-pound payload in the payload bay. The OMS pod crossfeed lines allow the propellants in the pods to be used to operate either OMS engine.

Fuel (monomethyl hydrazine) and oxidizer (nitrogen tetroxide) are stored in domed cylindrical titanium tanks within each pod. The propellant tanks, which are pressurized by the helium system, are divided into forward and aft compartments. The propellant tank's nominal operating pressure is 250 psi, with a maximum operating pressure limit of 313 psia.

11.2.5 Thrust Vector Control (TVC): The OMS engines are attached to the orbiter in gimbal mounts that allow the engines to pivot up and down and from side to side. The OMS TVC system consists of a gimbal ring assembly, two gimbal actuator assemblies, and two gimbal actuator controllers. The engine gimbal ring assembly and gimbal actuator assemblies provide OMS TVC by gimbaling the engines in pitch and yaw. Each engine has a pitch actuator and a yaw actuator. Each actuator is extended or retracted by one of a pair of dual-redundant electric motors and is actuated by general purpose computer (GPC) control signals.

11.3 OMS Operations

OMS operations can be controlled manually or automatically. Manual OMS use is accomplished through the throttle located at the Mission Commander station, and automatic use is handled by the

digital autopilot (DAP) located on switch panel 2 as well as the general-purpose computers (GPCs) located on switch panel 7. The Nitrogen Control Valve Switches are located on panel 3 and can be set to either GPC allowing only computer control or ON to allow manual control.

Crossfeed System: If either OMS pod's propellant system must be isolated from its nozzle, the other OMS propellant system can be configured to crossfeed propellant. The OMS crossfeed valves can be configured so that one OMS propellant system can feed both left and right OMS nozzles. The OMS crossfeed valves are AC-motor-operated valve actuators and identical in design and operation to the RCS propellant tank crossfeed valves. The OMS crossfeed valves are controlled by the LEFT OMS and RIGHT OMS CROSSFEED switches located on Panel 9. Opening the LEFT OMS CROSSFEED switches permits the left OMS to supply propellant or oxidizer to the right OMS crossfeed valves, which must be opened by placing the RIGHT OMS CROSSFEED switches to the OPEN position for propellant flow to the right OMS nozzle. (Note that the RIGHT OMS TANK ISOLATION valves should be closed.) Conversely, the crossfeed of the right OMS to the left OMS would be accomplished in the opposite order.

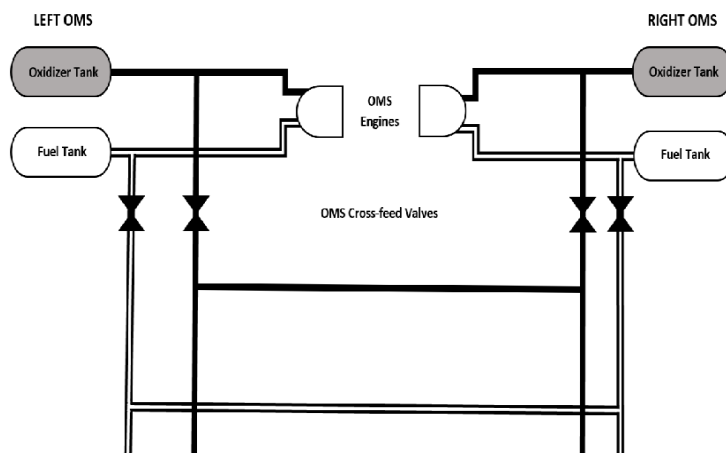

Note: The crossfeed system can also be configured to allow the OMS propellants to feed the RCS or the RCS to feed the OMS. RCS tanks are much smaller than the OMS and available propellant will be less. (See Reaction Control System)

11.4 OMS Mission Details

Under normal mission profile parameters, the OMS is used to automatically assist the main engine burn during ascent. The OMS engines will begin firing at approximately T+2:05 just after the completion of SRB separation. A 4000-lb OMS assist burn takes about 1:42 to complete and provides a 250-lb performance gain. Post MECO, the auto OMS-1 burn is then used to achieve orbit circularization. A direct-insertion ascent profile allows the main propulsion system to provide more energy for orbit insertion. An OMS-2 burn is not typically required unless mission parameters call for a transition to a higher orbit. The two OMS engines are used during deorbit. After setting the vehicle to retrograde, the flight crew will begin this maneuver by setting the OMS nitrogen control switches to enable (on). Target data for the deorbit maneuver are computed by mission control. These data are voiced to the flight crew for verification. After verification, mission control will direct the flight crew to begin manual OMS burn for the allotted time.

11.5 OMS Caution and Warning System

OMS ANNUNCIATOR PANEL SCHEMATIC

O2 PRESS	H ₂ PRESS	SMOKE / FIRE	LANDING SYS	FUEL CELL TEMP
CABIN ATM	H ₂ /O ₂ HEATER TEMP	MAIN BUS VOLTAGE	AC VOLTAGE	AC O/U LOAD
FREON LOOP	AV BAY/CABIN AIR	IMU	RCS FWD	RCS JET
H ₂ O LOOP	SRB LEFT	MAIN ENGINE LEFT	RCS LEFT	RCS RIGHT
PAYLOAD BAY	SRB RIGHT	MAIN ENGINE CNTR	OMS LEFT	OMS RIGHT
PAYLOAD	GPC	MAIN ENGINE RIGHT	NAV SYSTEM	OMS TVC
ALARM	APU TEMP	APU SPEED	H ₂ O SPRAY BOILER	HYD PRESS

The Orbiter OMS caution and warning system is located on the Flight Engineer Data Panel in the annunciator matrix. OMS alerts can be caution (yellow) or warning (red). Caution lights may indicate a system value out of nominal but still within accepted parameters. Warning lights indicate a malfunction in the system that must be repaired. These alerts can be used in conjunction with notifications listed in the information box (Blue Box) on the Basic Control Data Panel (Pilot's Panel) to complete emergency procedures.

OMS LEFT: Indicates detection of a left OMS pod oxidizer or fuel tank ullage pressure out of limits, or an engine abnormal (OMS engine fail to cutoff, fail to ignite, or early shutdown) condition.

OMS RIGHT: Indicates detection of a right OMS pod oxidizer or fuel tank ullage pressure out of limits, or an engine abnormal (OMS engine fail to cutoff, fail to ignite, or early shutdown) condition.

OMS TVC: Indicates detection of an OMS pitch or yaw gimbal failure. An OMS TVC failure may indicate a failure in the GPC. OMS TVC failure may precipitate a LEFT or RIGHT OMS failure.

OMS Summary

Summary:

- The OMS provides propulsion for orbit insertion, orbit circularization, orbit transfer, rendezvous, and deorbit.
- The OMS engines are collocated with the aft RCS in two independent OMS/RCS pods on each side of the orbiter's aft fuselage. Each engine produces 6,087 pounds of thrust.
- The OMS engines use monomethyl hydrazine as fuel and nitrogen tetroxide as oxidizer. The propellants are hypergolic.
- Gaseous pressurized nitrogen operates the OMS engine valves and is also used to purge the fuel lines at the end of each burn. Propellant flow to the engines is maintained by a helium pressurization system.
- Each OMS/RCS pod contains one OMS fuel tank and one OMS oxidizer tank. Crossfeed lines allow propellants to be used to operate either engine. OMS propellant can also be fed to aft RCS jets.
- OMS engines are attached to the orbiter in gimbal mounts that allow the engines to pivot up and down and from side to side ($\pm 6^\circ$ pitch, $\pm 7^\circ$ yaw).
- Each OMS engine is capable of 1,000 starts and 15 hours of cumulative firing. The minimum duration of an OMS engine firing is 2 seconds.
- Switches used to operate the OMS are located on panels 2 (DAP), 7 (GPCs), and 3 (N₂ CNTRL).
- Cross feed switches are located on panel 9.

Rules of Thumb

- 1 percent of OMS propellant = 6 fps
- 130 lb. (80 lb. oxidizer, 50 lb. fuel) uses 400 psi of helium.
- One OMS engine causes approximately 1 fps² acceleration.
- For OMS ignition, there must be power on both control valves.
- FUEL INJECTOR TEMP message may be a signature of a bad temperature transducer or a fuel blockage.
- CHAMBER PRESSURE message may be a signature of a bad pressure transducer or an oxidizer blockage.
- Max blowdown on the OMS is approximately 39 percent.

12 REACTION CONTROL SYSTEM (RCS)

12.1 Introduction

The orbiter's Reaction Control System is responsible for providing precise control of the Shuttle's orientation and movement in space. This chapter provides an overview of the RCS, its components, and how it works.

The RCS consists of forward and aft control jets, propellant storage tanks, and distribution networks located in three vehicle modules: forward, left, and right. The forward module is contained in the nose area, forward of the cockpit windows. The left and right (aft) modules are collocated with the orbital maneuvering system (OMS) in the left and right OMS/RCS pods near the tail of the vehicle. Each RCS consists of high-pressure gaseous helium storage tanks, pressure regulation and relief systems, a fuel and oxidizer tank, a propellant distribution system, reaction control jets, and electrical jet and pod heaters.

12.2 RCS Components

The RCS consists of several components that work together to provide the Shuttle with precise control in space. These components include:

12.2.1 RCS Thrusters: The RCS thrusters are small rocket engines that provide the Shuttle with the thrust required for maneuvering in space via jets located at multiple points around the vehicle.

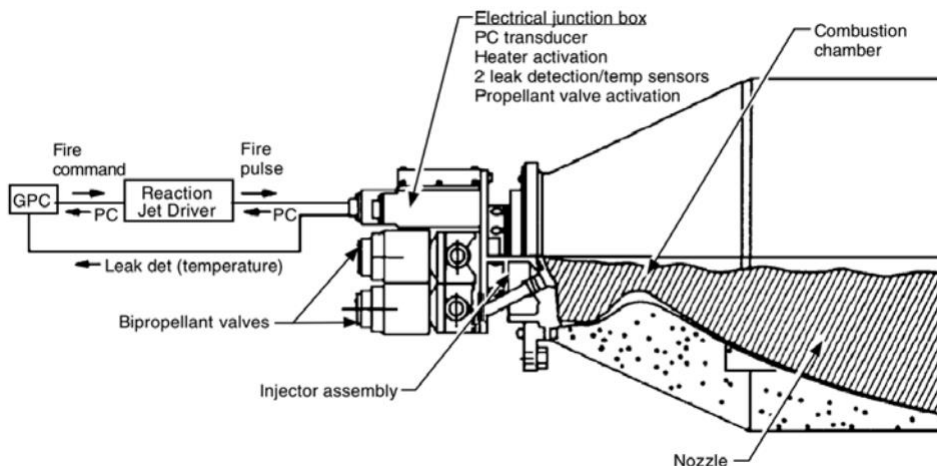

12.2.2 RCS Jets: There are a total of 44 RCS jets; 38 primary and 6 vernier. The primary RCS jets provide 870 pounds of vacuum thrust each, and the vernier RCS jets provide 24 pounds of vacuum thrust each for precise maneuvering. The vernier jets are only used in orbit for fine attitude control.

- The forward RCS has 14 primary and 2 side-firing vernier jets. These jets are subdivided into clusters: 4 primary jets and 1 vernier jet each in the left and right side cluster groups while the upper fuselage cluster group has 6 primary jets.
- The aft RCS has 12 primary and 2 vernier jets in each pod for a total of 28. These jets are also subdivided into 4 clusters per pod.

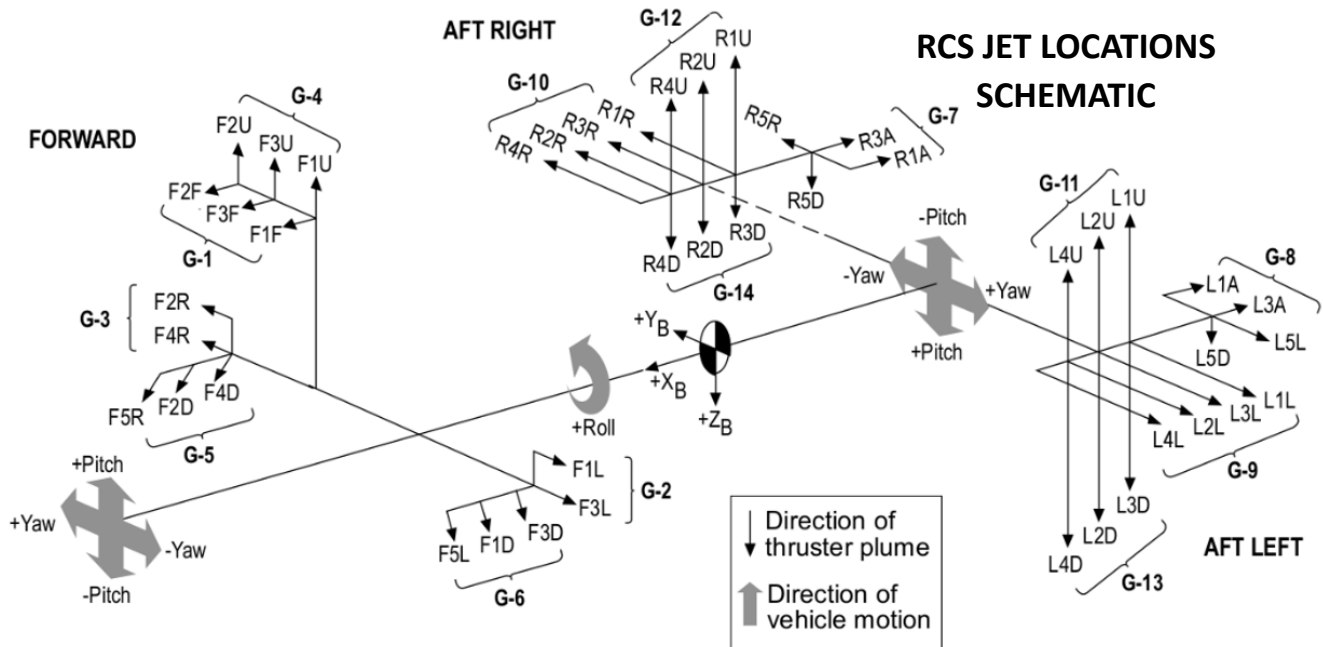

12.2.3 RCS Fuel/Oxidizer: Two helium tanks supply gaseous helium to pressurize oxidizer and fuel tanks. The oxidizer and fuel are then supplied under pressure to the RCS jets. Nitrogen tetroxide (N₂O₄) is the oxidizer, and monomethyl hydrazine (MMH) is the fuel. The propellants are toxic liquid at room temperature, and hypergolic (they ignite upon contact with each other). The propellants are supplied to the jets, where they atomize, ignite, and produce a hot gas and thrust.

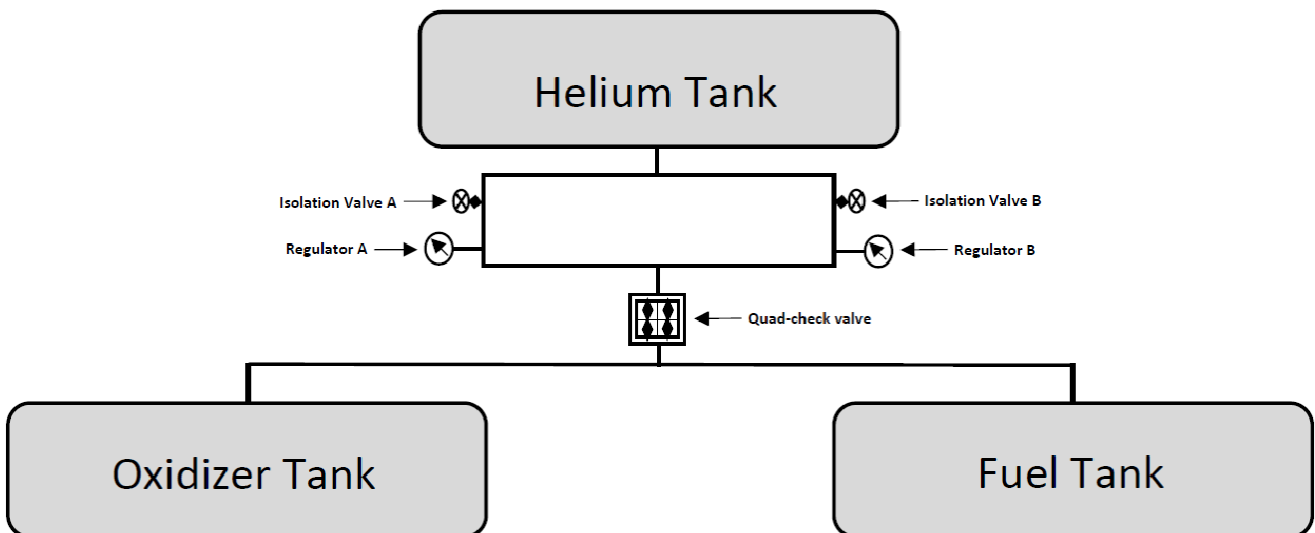

12.3 RCS Operations

RCS operations can be controlled manually or automatically. Manual RCS use is accomplished through joysticks located at the Mission Commander and Pilot stations, and automatic use is handled by the digital autopilot (DAP) located on switch panel 2 and the general-purpose computers (GPCs) located on switch panel 7.

The primary jets are manually operable in a maximum steady-state mode of 1 to 180 seconds, with a maximum mission contingency of 840 seconds for the aft RCS jets and 420 seconds maximum for the forward RCS jets.

Plumbing System: The system that distributes the propellants to the RCS jets consists of helium, fuel, and oxidizer tanks, tank isolation valves, manifold isolation valves, crossfeed valves, distribution lines, and filling and draining service connections. Manipulation of the flow and path of propellant is possible with manual or automatic adjustments of these valves.

12.3.1 Tank isolation valves: Each tank in the system has an isolation valve to separate it from the rest of the system.

- a. **Helium Tank Isolation Valves (HTIV)** Two parallel isolation valves are located between the helium tanks and the pressure regulators in each RCS. When open, the helium tank isolation valves permit the helium source pressure to flow to the propellant tanks. The helium tank isolation valves are controlled by the RCS FWD TANK ISOL A and B switches and the RCS AFT LEFT and RIGHT TANK ISOL A and B switches located on panel 3. Helium pressure is then regulated by two regulator assemblies, downstream of the helium tank isolation valves. Each assembly contains two stages, a primary and a secondary, connected in series. If the primary stage fails open, the secondary stage regulates the pressure. The primary stage regulates pressure at 242 to 248 psig, the secondary at 253 to 259 psig. Lastly, a quad check valve assembly is located between the pressure regulator assemblies and the propellant tank. The arrangement of the check valve limits the backflow of propellant vapor and maintains propellant tank pressure integrity in the event of an upstream helium leak.
- b. **Fuel/Oxidizer Terminal Valves (FTV/OTV)** The propellant tanks each have a terminal valve located directly downstream from the tank. These valves are AC-motor-operated and consist of a lift-off ball flow control device and an actuator assembly that contains a motor, gear train, and actuator gear. OTV and FTV valves are controlled by switches located on Panel 8 (touch screen) under RCS.

12.3.2 Leg and Manifold Isolation Valves: Each RCS jet cluster group has a Fuel Manifold and Oxidizer Manifold that can be isolated from the rest of the system. Additionally, cluster groups can be further isolated using the leg isolation valves. The RCS manifold isolation valves are between the tank terminal valves and the RCS jets. The valves for manifolds are the same type of AC-motor-operated

valves as the propellant tank terminal valves and are controlled by the same type of motor switching logic. Switches for these valves are located on Panel 8 (touch screen) under RCS.

Note: The manifold isolation valves have a backflow capability when the manifold is closed, and the manifold pressure is 30 to 50 psi higher than the tank leg. This allows propellant pressure to be relieved at the manifold.

12.3.3 Crossfeed System: If either aft RCS pod's propellant system must be isolated from its jets, the other aft RCS propellant system can be configured to crossfeed propellant. The aft RCS crossfeed valves can be configured so that one aft RCS propellant system can feed both left and right RCS jets. The aft RCS crossfeed valves are AC-motor-operated valve actuators and identical in design and operation to the propellant tank terminal valves. The aft RCS crossfeed valves are controlled by the AFT LEFT and AFT RIGHT RCS CROSSFEED switches located on Panel 9. The OPEN position of the AFT LEFT RCS CROSSFEED switch permits the aft left RCS to supply propellants to the aft right RCS crossfeed valves, which must be opened by placing the AFT RIGHT RCS CROSSFEED switch to the OPEN position for propellant flow to the aft right RCS jets. (Note that the AFT RIGHT TANK ISOLATION valves should be closed. The crossfeed of the aft right RCS to the left RCS would be accomplished by positioning the AFT RIGHT and LEFT RCS CROSSFEED switches to OPEN and positioning the AFT LEFT RCS TANK ISOLATION switches to CLOSE. (See Schematic 12)

Note: The crossfeed system can also be configured to allow the OMS propellants to feed the RCS or the RCS to feed the OMS. RCS tanks are much smaller than the OMS and available propellant will be less. (See Orbital Maneuvering System)

12.4 RCS Mission Details

Under normal mission profile parameters, after main engine cutoff, the DAP controls the forward and aft RCS jets to maintain attitude hold until external tank separation. During ET separation, the RCS provides a negative Z translation maneuver of about 4 feet per second to move the orbiter away from the external tank. Upon completion of the maneuver, the RCS holds the orbiter attitude until it is time to maneuver to the OMS burn attitude.

The OMS burn uses both OMS engines to raise the orbiter to a predetermined circular orbit. During the OMS burn, vehicle attitude is maintained by gimbaling (swiveling) the OMS engines. The RCS normally does not operate during an OMS burn. If, during an OMS burn, the gimbal rate or gimbal limits are exceeded, RCS roll control would be required; or if only one OMS engine is used during a burn, RCS roll control may be required. Upon completion of the OMS burn, the RCS is used to automatically null any residual velocities, if required.

The next step involves using the RCS manually to move the orbiter into a prograde attitude. This is completed by the mission commander and consists of setting the orbiter to zero degrees in the X, Y, and Z axes (also known as "Zero Up") while using the Orbit Earth HUD. On orbit, the DAP will use the

vernier jets for fine attitude control, and the primary jets for coarse attitude control and minor translations.

Before the deorbit burn, the flight crew uses the macro pad located on panel 4 to automatically maneuver the spacecraft to a retrograde attitude using the RCS jets. After the deorbit burn is complete, the flight crew again uses macro key commands to automatically maneuver the spacecraft back to a prograde attitude. This aligns the orbiter for a proper reentry interface. During landing, the RCS is deactivated using the macro pad at an altitude of approximately 35,000m.

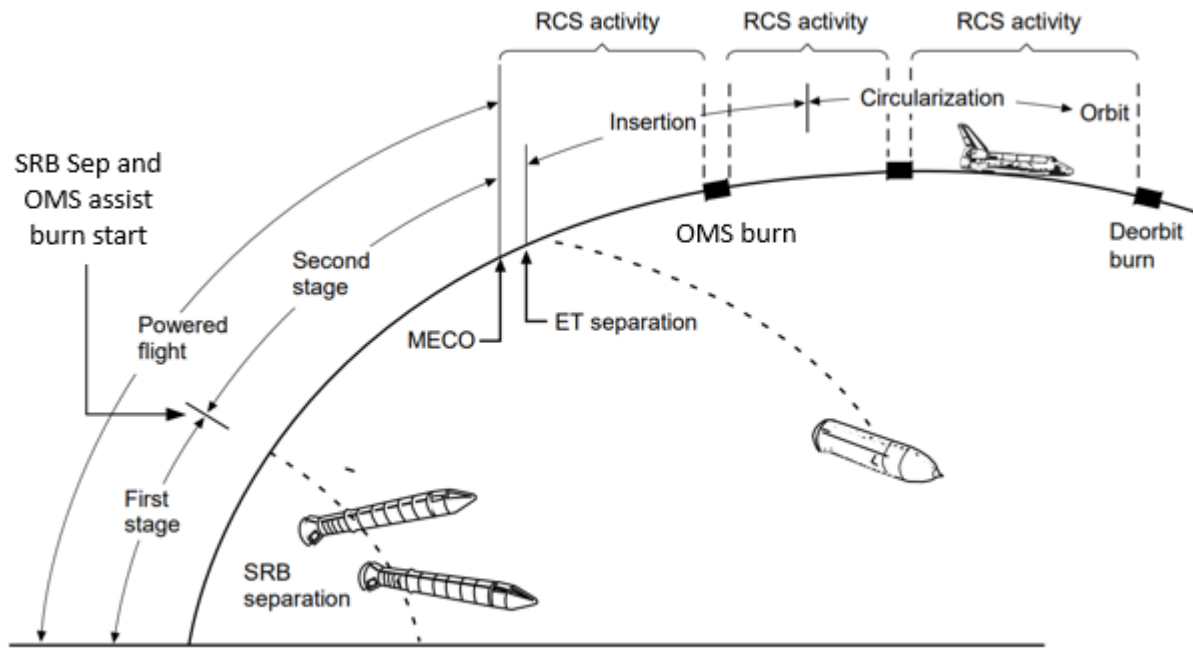

Nominal Ascent Profiles

12.5 RCS Caution and Warning System

RCS ANNUNCIATOR PANEL SCHEMATIC

O ₂ PRESS	H ₂ PRESS	SMOKE / FIRE	LANDING SYS	FUEL CELL TEMP
CABIN ATM	H ₂ /O ₂ HEATER TEMP	MAIN BUS VOLTAGE	AC VOLTAGE	AC O/U LOAD
FREON LOOP	AV BAY/CABIN AIR	IMU	RCS FWD	RCS JET
H ₂ O LOOP	SRB LEFT	MAIN ENGINE LEFT	RCS LEFT	RCS RIGHT
PAYLOAD BAY	SRB RIGHT	MAIN ENGINE CNTR	OMS LEFT	OMS RIGHT
PAYLOAD	GPC	MAIN ENGINE RIGHT	NAV SYSTEM	OMS TVC
ALARM	APU TEMP	APU SPEED	H ₂ O SPRAY BOILER	HYD PRESS

The Orbiter RCS caution and warning system is located on the Flight Engineer Data Panel in the annunciator matrix. RCS alerts can be caution (yellow) or warning (red). Caution lights may indicate a system value out of nominal but still within accepted parameters. Warning lights indicate a malfunction in the system that must be repaired. These alerts can be used in conjunction with notifications listed in the information box (Blue Box) on the Basic Control Data Panel (Pilot's Panel) to complete emergency procedures.

RCS JET: Indicates detection of an RCS jet failed on, failed off, or leaking.

RCS FWD: Indicates detection of an out of limits condition on a forward RCS oxidizer tank ullage pressure, fuel tank ullage pressure, or forward oxidizer or fuel leak.

RCS LEFT: Indicates detection of an aft left RCS oxidizer, fuel tank ullage pressure out of limits, or left oxidizer or fuel leak.

RCS RIGHT: Indicates detection of an aft right RCS oxidizer, fuel tank ullage pressure out of limits, or right oxidizer or fuel tank leak.

The red RCS FWD, RCS LEFT, or RCS RIGHT warning light will illuminate if propellant tank ullage pressure is less than 200 psia or higher than 312 psia. Exceeding a preset difference of 9.5 percent between fuel and oxidizer propellant quantities will also illuminate the appropriate one of these lights.

RCS (FWD, LEFT, RIGHT) warning lights can also be triggered by propellant tank temperature exceeding upper (90° F) or lower (50° F) limits or by the loss of pressure or temperature data that is needed for RCS quantity calculations.

RCS Summary

Summary:

- The RCS consists of forward and aft systems of control jets, propellant storage tanks, and distribution networks located in three separate vehicle modules.
- The forward module is in the nose area, and the left and right aft modules are in the left and right OMS/RCS pods near the tail of the vehicle.
- The forward RCS has 14 primary and two vernier jets; the aft RCS has 12 primary and two vernier jets per pod.
- Primary jets provide 870 pounds each of vacuum thrust; vernier 24 each. The vernier jets are only used on orbit for fine attitude control.
- Manual RCS use is through joysticks located at the Mission Commander and Pilot stations, and automatic use is handled by the digital autopilot and the general-purpose computers.
- Nominal uses of the RCS include ET separation, and trim residuals during ascent; attitude control and maneuvers in orbit; and entry flight control and center of gravity management.
- Off-nominal uses include single-engine roll control, RCS wraparound during OMS burn, OMS completions, and abort dumps.

- RCS jets are fueled with N_2O_4 and MMH. The propellants are liquid at room temperature and hypergolic.
- Propellant quantities are monitored on the orbiter screen in the upper left data panel.
- Helium tank isolation valve switches are located on panel 3.
- All other isolation valve switches are located on panel 8 (touch screen)
- All crossfeed valve switches are located on panel 9.

Rules of Thumb

- 1% RCS prop = 1 fps ΔV .
- 1% RCS prop = 22 lb.
- If fuel tank pressure is 20 psi higher than the oxidizer tank pressure, then verniers are no go.
- Always secure the RCS from the manifolds up to the helium tanks.
- Always open the RCS from the helium tanks down to the manifolds.

13 WASTE MANAGEMENT SYSTEM (WMS)

13.1 Introduction

The waste management system (WMS) is an integrated, multifunctional system used primarily to collect and process crew biological waste. The system collects, stores, and dries fecal wastes. It processes urine and transfers it to the wastewater tank.

The system also provides an interface for venting trash container gases overboard and dumping atmospheric revitalization wastewater overboard in a contingency situation, and it transfers atmospheric revitalization system wastewater to the wastewater tank.

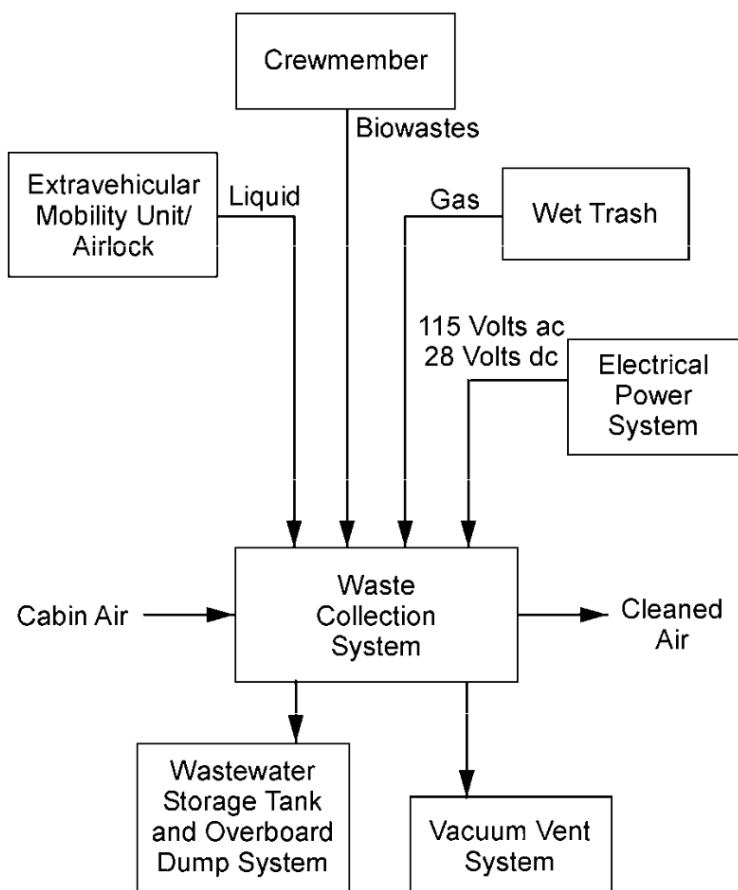

WASTE MANAGEMENT SYSTEM

13.2 WMS Operations

The WMS consists of a commode, urinal, fan separators, odor/bacteria filter, vacuum vent quick disconnect, and controls.

The commode contains a single multilayer hydrophobic porous bag liner for collecting and storing solid waste. When the commode is in use, it is pressurized, and transport air flow is provided by the fan separator. When the commode is not in use, it is depressurized for solid waste drying and deactivation.

The urinal assembly is a flexible hose with attachable funnels that can accommodate both men and women. The assembly can be used in a standing position.

All waste management system gases are ducted from the fan separator into the odor/bacteria filter and then mixed with cabin air. The filter can be removed for in-flight replacement.

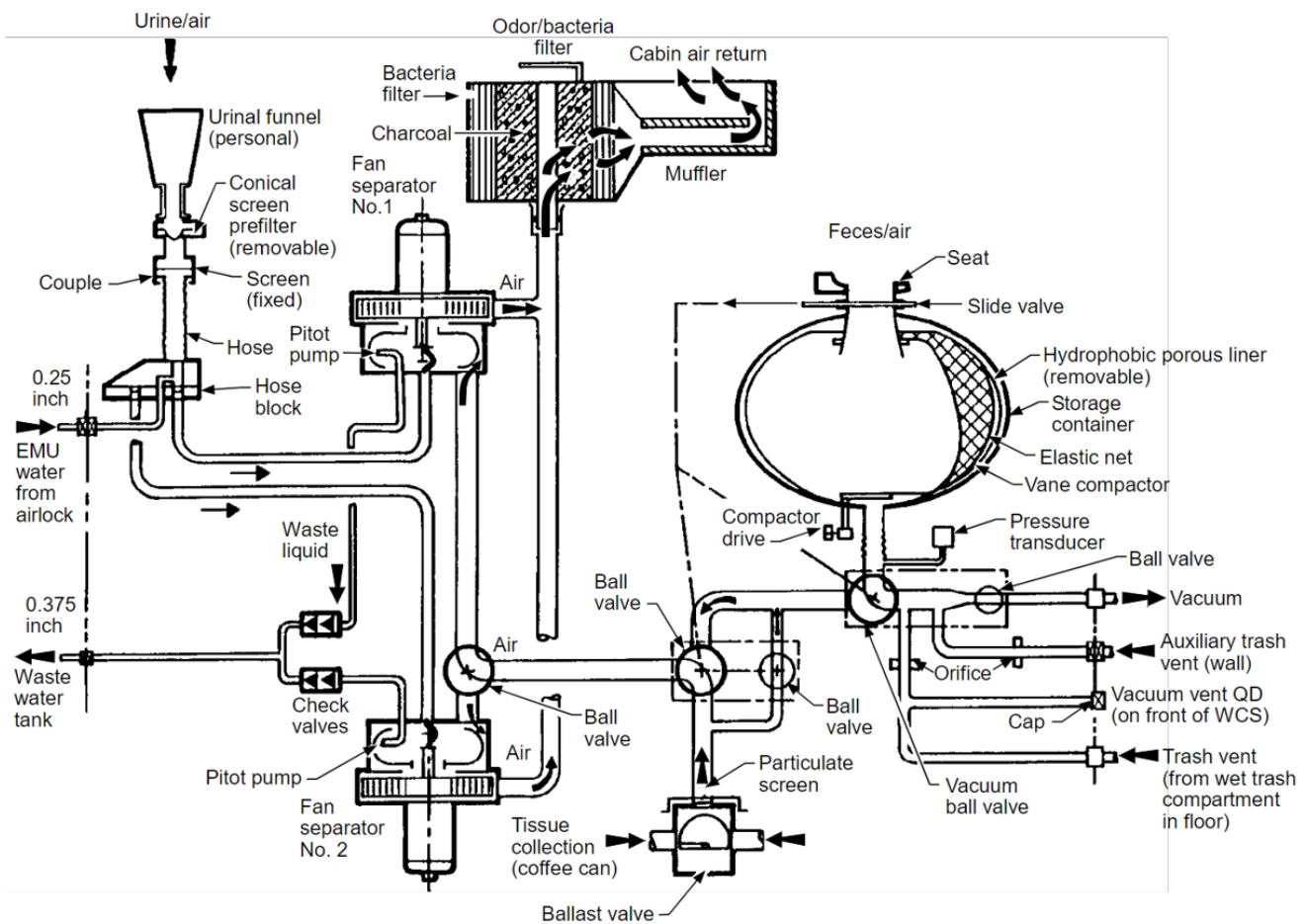

Various restraints and adjustments enable the crew to achieve the proper body positioning to urinate or defecate in a zero-gravity environment. Two foot restraints are provided. A toe bar is located at the commode base and is used for standing urination. A footrest restrains the feet of a crewmember sitting on the commode. The footrest consists of an adjustable platform with detachable Velcro straps for

securing the feet. Handholds are used for positioning or stabilizing the crewmember and form an integral part of the top cover of the waste management collection system assembly.

The WMS compartment is stocked with gloves, trash bags, tissues, and wet wipes. Rubber grommets in the compartment allow crewmembers to restrain their towels and washcloths.

For launch and entry, the VACUUM VALVE switch is set to CLOSE. During on-orbit operations, when the WCS is not in use, the vacuum valve is set to OPEN. This exposes the commode overboard via the vacuum vent system, and any solid wastes in the commode are dried. This also allows venting of the auxiliary wet trash and the volume F wet trash compartment. The hydrophobic bag liner in the commode allows gas from the commode to vent overboard but does not allow the passage of free liquid.

The WCS is used like a normal toilet. The commode seat is made of a contoured, hard plastic material that provides proper positioning and is sealed to minimize air leakage.

FLIGHT DATA FILES

The Flight Data Files (FDF) are the total complement of documentation and related aids available to the flight crew and mission control team for flight execution. These files include mission checklists, switch panel diagrams, emergency procedure checklists, and vehicle schematics.

14 MISSION CHECKLIST

14.1 Introduction

The mission checklists are the road map to the orbiter flight. The checklists will guide the crew through the stages of the flight and if correctly followed, will provide all the switch settings necessary for a successful flight. There are three different versions of the mission checklist, all of which contain the same flight information, each with some different formatting and helpful hints:

- Mission Checklist – Classroom
- Mission Checklist – Kneeboard
- Mission Checklist – Simulator

Notes: 1) This manual only contains the Simulator Mission Checklist. For the other versions, please visit the SAC website. 2) This is a generic version of the checklist. For mission specific checklists, please visit the SAC website.

The basic checklist format is four columns divided into a variable number of rows. The columns are named COM, TIME, PROCEDURE and Mission Control Notes and the rows are identified by the number in the first block of each row, the COM block. Be aware that the line spacing within each row is significant. Multiple blank lines in the PROCEDURE block of the row indicates that there is information contained in the Mission Control Notes block and the flight crew must pause to wait for mission control to act on that information.

The **COM** column name stands for Communications block and contains sequentially ascending numbers. The COM block can be used to help all team members locate the current checklist location and it is recommended that it be included in time checks performed by Mission Control.

The **TIME** column displays the current mission time for the beginning of the block. The TIME value will be one of three types: Countdown, Mission Elapsed (MET) or Mission Dependent. The Countdown time will be from the T-00:05:00 Launch Hold to T-00:00:00 Launch, also known as T-minus time. The Mission Elapsed time (MET) will be from T+00:00:01 to mission dependent time, also known as T-plus time. The Mission Dependent time is when the timing of a block is determined by the mission parameters and therefore may change for each mission. (Note that the TIME block changes to ALTITUDE in the Landing Checklist phase of the flight, and it represents the Orbiter altitude in Kilometers).

The **PROCEDURE** column contains the commands that will be given to the flight crew by the flight engineer. These commands direct the flight crew to set the switches in the proper position or contain information or verification requests from the flight engineer.

The **Mission Control Notes** column contains announcements and advisements that will be requested by Mission Control.

Pre-Launch Checklist

COM	TIME	PROCEDURE	Mission Control Notes
1	T-00:05:00	<p><u>Launch HOLD</u></p> <p>CABIN DOOR to LATCH</p> <p>ENVIRONMENTAL SYSTEM O₂ SYS to OPEN</p> <p>ENVIRONMENTAL SYSTEM N₂ SYS to OPEN</p> <p>ENVIRONMENTAL SYSTEM H₂O LOOP to OPEN</p> <p>Key in ITEM Select A Key in DPS Select 1 (OPS 1) Key in EXEC</p> <p>BOILER CNTRL POWER (1/2/3) to ON</p> <p>BOILER CNTRL HEATER (1/2/3) to ON</p> <p>BOILER N₂ SUPPLY (1/2/3) to OPEN</p> <p>Key in DPS Select 2 (OPS 2) Key in EXEC</p>	<p>Advise: Go for Load OPS 1 and Execute</p> <p>Announce: Confirm Water Spray Boiler On</p> <p>Advise: Check Boiler Temp</p> <p>Advise: Go for Load OPS 2 and Execute</p> <p>Advise: Go for Cabin Leak Check</p> <p>Advise: Go for Helium (He) Pressurization</p>

<p>1 cont.</p>		<p>PNEUMATIC He ISOL (LEFT/CENTER/RIGHT) to OPEN</p> <p>APU FUEL TNK VLV (1/2/3) to CLOSE</p> <p>APU SHUTDOWN to ENABLE</p> <p>HYD MAIN PUMP PRESSURE (1/2/3) to LOW</p> <p>APU SPEED SELECT (1/2/3) to NORMAL</p> <p>HYD CIRC PUMP (1/2/3) to GPC</p> <p>APU MAIN POWER to ON</p> <p>APU CNTRL POWER (1/2/3) to ON</p> <p>APU MSTR VLV to OPEN</p> <p>APU FUEL TNK VLV (1/2/3) to OPEN</p> <p>APU/HYDRAULICS (1/2/3) to RUN</p> <p>HYD MAIN PUMP PRESSURE (1/2/3) to NORMAL</p> <p>HYD CIRC PUMP (1/2/3) to OFF</p> <p>Confirm central HUD is on and in <u>Orbit Earth</u> Mode.</p> <ul style="list-style-type: none"> • <i>If needed</i> Select 0 (toggle until <u>Orbit Earth</u> HUD is visible) <p>STAR TRACKER to ON</p> <p><i>C - <u>Request Go/No Go for launch</u></i></p>	<p>Announce: APU Pre-Start Check Is Underway</p> <p>Advise: Check Vent Temp</p> <p>Announce: Nominal APU Start</p> <p>Advise: Mission Control confirms all systems are nominal. You are Go for launch.</p> <p><u>OR</u></p>
<p>1 cont.</p>			

<p>1 cont.</p>		<p>Initiate Launch Clock Restart when <u>Go</u> order received</p> <p>MAIN ENGINE POWER (LEFT/CENTER/RIGHT) to ENABLE</p> <p>N₂ CNTRL VLV LEFT (1/2) to ENABLE</p> <p>N₂ CNTRL VLV RIGHT (1/2) to ENABLE</p>	<p>Mission Control confirms some systems are Off-Nominal. You are No Go for launch until these systems are corrected.</p> <p>Advise: Go for Main Propulsion System (MPS) initialization</p> <p>Advise: Go for OMS Engines Initialization</p> <p>Announce: Stand by to Initiate radar at exactly T-4:00</p>
<p>2</p>	<p>T-00:04:00</p>	<p>PRIMARY SYSTEM RADAR to ON</p> <p>RATE GYRO ASSEMBLY (RG1/RG2-3/RG4) to ON</p> <p>INTERNAL SHUTTLE SYSTEM PWR (BAT A/ BAT B) to ON</p> <p>INTERNAL SHUTTLE SYSTEM POWER - INT PWR TRANSFER to ON</p>	<p>Announce: Synchronization of Fuel Cells Underway</p> <p>Announce: Confirming Shuttle Is On Internal Power</p>
<p>3</p>	<p>T-00:03:00</p>	<p>Key in DPS Select 3 (OPS 3)</p> <p>GLOBAL POSITIONING SYSTEM (GPS-1/GPS-2/GPS-3) to ON</p>	<p>Advise: Go for Load OPS 3</p> <p>Announce: External Tank Cap is retracted</p> <p>Advise: Check Hydraulic (APU) Pressure</p>

4	T-00:02:00	<p>APU SHUTDOWN to INHIBIT</p> <p><i>Verify</i> SRB JETTISON is GPC</p> <p><i>Verify</i> EXT TANK JETTISON is GPC</p>	<p>Announce: Confirm APU Power Shutdown is inhibited</p> <p>Announce: External Tank Liquid Hydrogen vents are closed.</p>
5	T-00:01:00	<p>AC BUS SENSOR to MONITOR</p> <p>INTERNAL SHUTTLE SYSTEM POWER - EXT PWR DISCONNECT to ON</p>	<p>Announce: Confirm ground power disconnect complete.</p> <p>Advise: Mission Commander - You are Go for Executing OPS 3 at T-4 seconds</p>
6	T-00:00:04	Key in EXEC	Advise: Go for Execute OPS 3
7	T-00:00:00		<p>Initiate Mission Elapsed Time Clock</p> <p>Announce: Shuttle liftoff, the clock is running</p>

Ascent Checklist

COM	MET	PROCEDURE	Mission Control Notes
8	T+00:00:20	Switch Left MFD back to Surface Mode Key in 9	
9	T+00:00:44		Announce: Automatic Main Engines Throttle Down to 65%
10	T+00:01:10		Announce: Automatic Main Engines Throttle Up to 104%
11	T+00:02:05	<i>SRB Separation</i> FREON LOOP to OPEN H ₂ O HX to OPEN AIR HX to OPEN	Announce: OMS assist burn start
12	T+00:03:00		Advise: Check Flash Evaporator Is Operational
13	T+00:04:20		Advise: Negative Return
14	T+00:05:00	INTERNAL SHUTTLE SYSTEM PWR (BAT A / BAT B) to STANDBY	Advise: Confirm Status of Fuel Cells
15	T+00:08:00		Advise: Go for Engines Automatic Throttle Down in Preparation for Main Engine Cutoff (MECO)
16	T+00:08:55	<i>Main Engine Cutoff (MECO)</i>	Advise: Confirm Main Engine Shutdown and Engine Cutoff (MECO)

Orbit Insertion Checklist (Post MECO)

COM	MET	PROCEDURE	Mission Control Notes
17	T+00:09:00	FWD RCS He TANK ISOL (A/B) to OPEN AFT RCS LEFT He TANK ISOL (A/B) to OPEN AFT RCS RIGHT He TANK ISOL (A/B) to OPEN	Announce: Initialize External Tank Separation system
18	T+00:09:20	<i>Confirm</i> N ₂ CNTRL VLV LEFT (1/2) are ENABLEd <i>Confirm</i> N ₂ CNTRL VLV RIGHT (1/2) are ENABLEd	Announce: Standing by for Auto OMS1 Burn
19	T+00:09:30	FLT CNTRL PWR to INHIBIT ENGINE DAP to AUTO	
20	T+00:09:45	MAIN ENGINE POWER (LEFT/CENTER/RIGHT) to OFF	
21	T+00:10:00	HYD MAIN PUMP PRESSURE (1/2/3) to LOW APU SHUTDOWN to ENABLE APU/HYDRAULICS (1/2/3) to OFF APU FUEL TNK VLV (1/2/3) to CLOSE APU MSTR VLV to CLOSE APU CNTRL POWER (1/2/3) to OFF APU MAIN POWER to OFF HYD CIRC PUMP (1/2/3) to GPC	

21 Cont.			Announce: APU Shutdown complete Announce: Confirm External Tank Separation
22	T+00:10:30	DUMP ISOL VLV to OPEN H ₂ RECIRC VLV to OPEN H ₂ OUTBOARD VLV to OPEN H ₂ INBOARD VLV to OPEN PNEUMATIC He ISOL (LEFT/CENTER/RIGHT) to GPC O ₂ VENT LINE to OPEN O ₂ OUTBOARD VLV to OPEN O ₂ INBOARD VLV to OPEN	Announce: MPS Propellants Automatic Dump initiated.
23	T+00:11:00 <u>approximate</u>	<i>Advise Mission Control when OMS Burn Initiated</i> BOILER N ₂ SUPPLY (1/2/3) to CLOSE BOILER CNTRL HEATER (1/2/3) to OFF BOILER CNTRL POWER (1/2/3) to OFF	Advise: Confirm OMS Burn Initiated
24	T+00:12:00 <u>approximate</u>	H ₂ RECIRC VLV to CLOSE H ₂ OUTBOARD VLV to CLOSE H ₂ INBOARD VLV to CLOSE O ₂ VENT LINE to CLOSE O ₂ OUTBOARD VLV to CLOSE O ₂ INBOARD VLV to CLOSE DUMP ISOL VLV to CLOSE	

24 Cont.			Announce: Auto MPS Propellant Dump Complete
25	T+00:14:00 <u>approximate</u>	AIR HX to GPC H ₂ O HX to GPC FREON LOOP to GPC	
26	T+00:15:10 <u>approximate</u>	<i>Advise Mission Control when OMS Burn Complete</i> N ₂ CNTRL VLV LEFT (1/2) to DISABLE N ₂ CNTRL VLV RIGHT (1/2) to DISABLE AC BUS SENSOR to AUTO	Advise: OMS Burn complete
27	Mission Dependent	Confirm central HUD is on and set to <u>Orbit Earth</u> mode. <ul style="list-style-type: none"> If needed Select 0 (toggle until <u>Orbit Earth</u> HUD is visible) H ₂ RECIRC VLV to GPC H ₂ OUTBOARD VLV to GPC H ₂ INBOARD VLV to GPC O ₂ VENT LINE to GPC O ₂ OUTBOARD VLV to GPC O ₂ INBOARD VLV to GPC ENGINE DAP to MANUAL FLT CNTRL POWER to ENABLE RATE GYRO ASSEMBLY (RG1/RG2-3/RG4) to OFF	Announce: Liquid H ₂ Fill & Drain Valves are set to Computer Control Announce: Liquid O ₂ Fill & Drain Valves are set to Computer Control

27 Cont.		Orient the shuttle to a zero attitude while using the <u>Kill Rotation</u> command (key 4) to stabilize the maneuver.	Advise: Go for Initiating Manual Zero Attitude Correction Announce: Confirm Shuttle in zero attitude (manual prograde)
28	Mission Dependent	PAYLOAD BAY POWER to ON PAYLOAD BAY DOOR to OPEN RADIATORS to DEPLOY Ku ANTENNA to DEPLOY	Advise: Go for payload bay door open program Announce: Confirm Payload Bay Doors are open Announce: Confirm Radiator Deployment Announce: Confirm KU Antenna Deployment Announce: Shuttle is correctly configured for the mission

De-Orbit Checklist

COM	MET	Procedure	Mission Control Notes
29	Mission Dependent	STAR TRACKER to OFF Ku ANTENNA to STOW RADIATORS to STOW PAYLOAD BAY DOOR to CLOSE PAYLOAD BAY POWER to OFF	Advise: Go for Payload Bay Door Close program. Announce: Confirm KU Antenna is stowed Announce: Confirm Radiators are stowed Announce: Confirm Payload Bay Doors are closed
30	Mission Dependent	BOILER CNTRL POWER (1/2/3) to ON BOILER CNTRL HEATER (1/2/3) to ON BOILER N ₂ SUPPLY (1/2/3) to OPEN	
31	Mission Dependent	<i>Position the Shuttle to The Correct Attitude – Retrograde</i> Key in 6 – Retrograde	Announce: Confirm Shuttle in retrograde attitude
32	Mission Dependent	DUMP ISOL VLV to OPEN PNEUMATIC He ISOL (LEFT/CENTER/RIGHT) to OPEN	Announce: Main Propulsion System Helium Release Initiated

33	Mission Dependent	APU MAIN POWER to ON APU CNTRL POWER (1/2/3) to ON APU MSTR VLV to OPEN APU FUEL TNK VLV (1/2/3) to OPEN APU SHUTDOWN to INHIBIT APU/HYDRAULICS (1/2/3) to RUN HYD MAIN PUMP PRESSURE (1/2/3) to LOW APU SPEED SELECT (1/2/3) to NORMAL HYD CIRC PUMP (1/2/3) to OFF	
34	Mission Dependent	PNEUMATIC He ISOL (LEFT/CENTER/RIGHT) to CLOSE DUMP ISOL VLV to CLOSE	Announce: Main Propulsion System Helium Release Completed
35	Mission Dependent	N ₂ CNTRL VLV LEFT (1/2) to ENABLE N ₂ CNTRL VLV RIGHT (1/2) to ENABLE Engine Throttle to Maximum Engine Throttle to OFF N ₂ CNTRL VLV LEFT (1/2) to DISABLE N ₂ CNTRL VLV RIGHT (1/2) to DISABLE	 Advise: Go for Performing De-orbit Burn Advise: Confirm De-orbit Burn Complete

36	Mission Dependent	<i>Position The Shuttle to The Correct Attitude – Prograde</i> Key in 7 – Prograde	Announce: Confirm Shuttle in prograde attitude
37	Mission Dependent	RE-ENTRY SYS CHECK to ON HYD MAIN PUMP PRESSURE (1/2/3) to NORMAL	
38	Mission Dependent	FWD RCS He TANK ISOL (A/B) to CLOSE AFT RCS LEFT He TANK ISOL (A/B) to CLOSE AFT RCS RIGHT He TANK ISOL (A/B) to CLOSE	Announce: Pressure cycle complete
39	Mission Dependent		Advise: De-Orbit Procedure is Complete

Landing Checklist







COM	Altitude	PROCEDURE	Mission Control Notes
40	35 k	<i>Disengage RCS mode</i> Key in D LANDING SYS to ARM LANDING SYS CHECK to ON LANDING SYSTEM RADAR to ON	
41	28 k	<i>(Lift takes affect)</i>	Announce: <i>Actual</i> altitude and speed
42	25 k	 <i>P – Announce: Kennedy VOR is Acquired</i> <i>P – Announce: Runway 15/33 ILS is Acquired</i>	Advise: Hydraulics/Brake Heater auto-activated Announce: <i>Actual</i> altitude and speed
43	2.5 k	GEAR to DEPLOY	Announce: Gear deployed
44	0.5 k (500 m)	SPEED BRAKE to DEPLOY	Announce: Speed Brake deployed
45	Touchdown	DROGUE CHUTE to DEPLOY	Announce: Touchdown
46			Announce: Wheels Stop
47		<i>End of Mission</i>	

15 SWITCH PANEL DIAGRAMS

15.1 Introduction

The following switch panel diagrams show the location of each control surface in the orbiter vehicle. All panels will notate where each switch, button, knob, and indicator LED is located.

The following information regarding control surfaces is shown for quick reference:

- Switches are indicated by: 
Switches may be either two position or three position indicated by either one LED or two LEDs respectively. Two position switches have one green LED to indicate the on or open position of the switch. Three position switches have a green LED for the upper position and a red LED for the lower position. The center position does not have any LED and indicates the GPC position. In this position, the component is computer controlled.
- Latching Buttons (push and lock) are indicated by: 
These buttons will light up when pushed to indicate the on or open position.
- Momentary buttons (push and release) are indicated by: 
These buttons must be pushed and released quickly to avoid sending a control command more than once. They are most often used to start computer-controlled programs such as the mission clock, radar, and system checks.
- Rotary switches are indicated by: 
The abort rotary switch can be used to select the desired abort mode before locking in the command with the ABORT button.
- LEDs are indicated by:  for green and  for red.

Switch Panel and Data Screens Layout

Orbiter Cockpit Layout

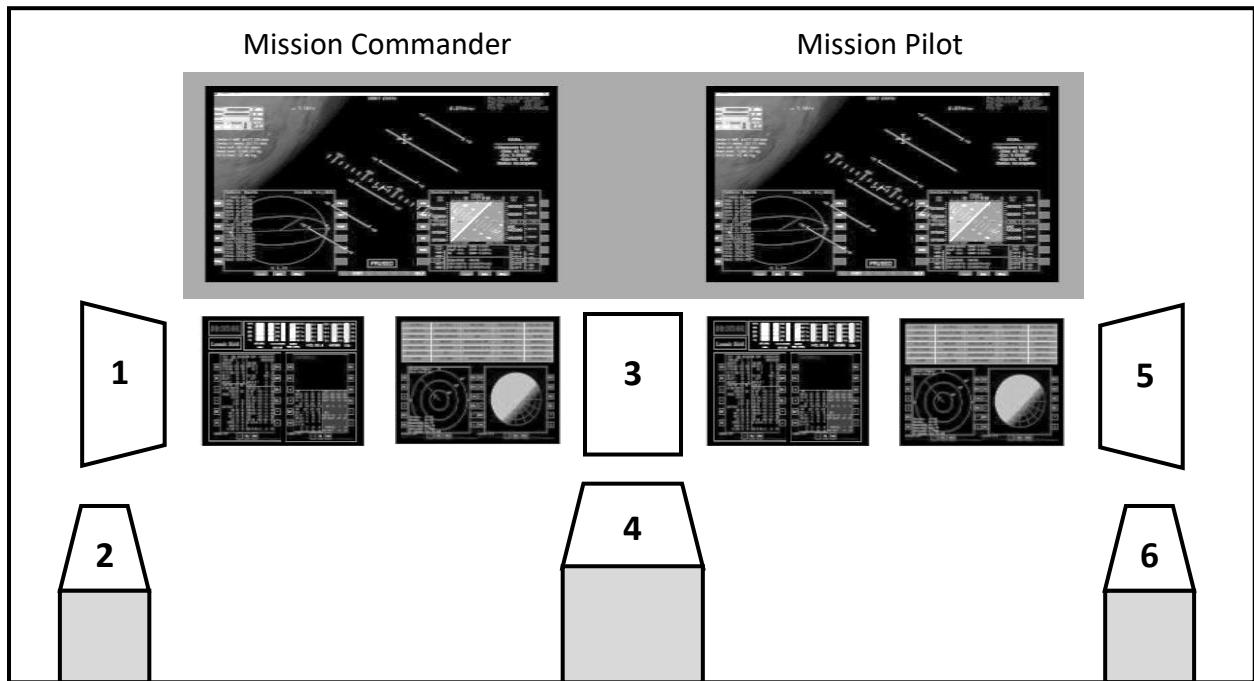

Flight Engineer Station Layout

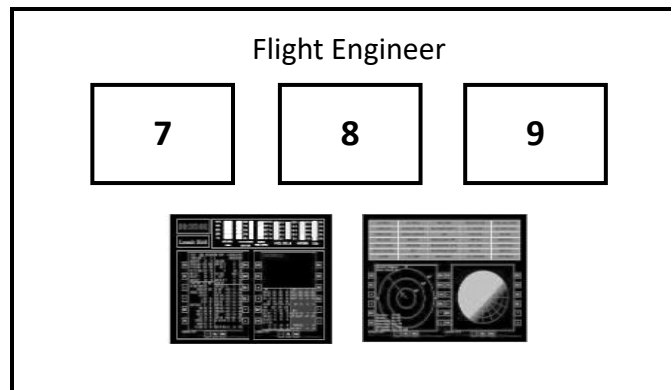

Orbiter Cockpit Panel 1

RATE GYRO ASSEMBLY

RG 1	RG 2-3	RG 4
ON <input type="radio"/>	ON <input type="radio"/>	ON <input type="radio"/>
⊕	⊕	⊕
OFF <input type="radio"/>	OFF <input type="radio"/>	OFF <input type="radio"/>

H₂ SYSTEM

H ₂ RECIRC	INBOARD	OUTBOARD
OPEN <input type="radio"/>	OPEN <input type="radio"/>	OPEN <input type="radio"/>
⊕	⊕	⊕
CLOSE <input type="radio"/>	CLOSE <input type="radio"/>	CLOSE <input type="radio"/>

O₂ SYSTEM

VENT LINE	INBOARD	OUTBOARD
OPEN <input type="radio"/>	OPEN <input type="radio"/>	OPEN <input type="radio"/>
⊕	⊕	⊕
CLOSE <input type="radio"/>	CLOSE <input type="radio"/>	CLOSE <input type="radio"/>

PNEUMATIC He ISOL

LEFT	CENTER	RIGHT
OPEN <input type="radio"/>	OPEN <input type="radio"/>	OPEN <input type="radio"/>
⊕	⊕	⊕
CLOSE <input type="radio"/>	CLOSE <input type="radio"/>	CLOSE <input type="radio"/>

APU / HYDRAULICS

1	2	3
RUN <input type="radio"/>	RUN <input type="radio"/>	RUN <input type="radio"/>
⊕	⊕	⊕
OFF <input type="radio"/>	OFF <input type="radio"/>	OFF <input type="radio"/>

APU SPEED SELECT

1	2	3
HIGH <input type="radio"/>	HIGH <input type="radio"/>	HIGH <input type="radio"/>
⊕	⊕	⊕
NORMAL <input type="radio"/>	NORMAL <input type="radio"/>	NORMAL <input type="radio"/>

HYD MAIN PUMP

1	2	3
NORMAL <input type="radio"/>	NORMAL <input type="radio"/>	NORMAL <input type="radio"/>
⊕	⊕	⊕
LOW <input type="radio"/>	LOW <input type="radio"/>	LOW <input type="radio"/>

HYD CIRC PUMP

1	2	3
ON <input type="radio"/>	ON <input type="radio"/>	ON <input type="radio"/>
⊕	⊕	⊕
OFF <input type="radio"/>	OFF <input type="radio"/>	OFF <input type="radio"/>

Orbiter Cockpit Panel 2

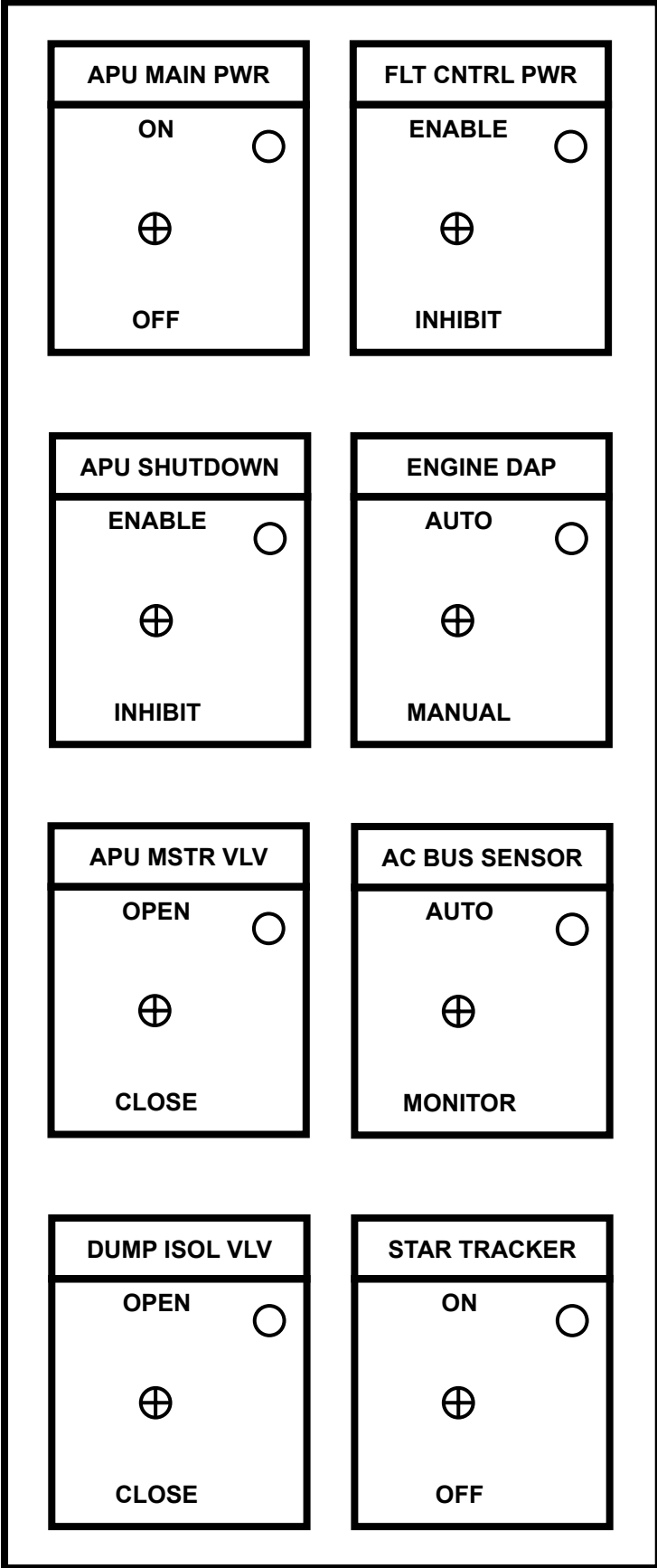

Orbiter Cockpit Panel 3

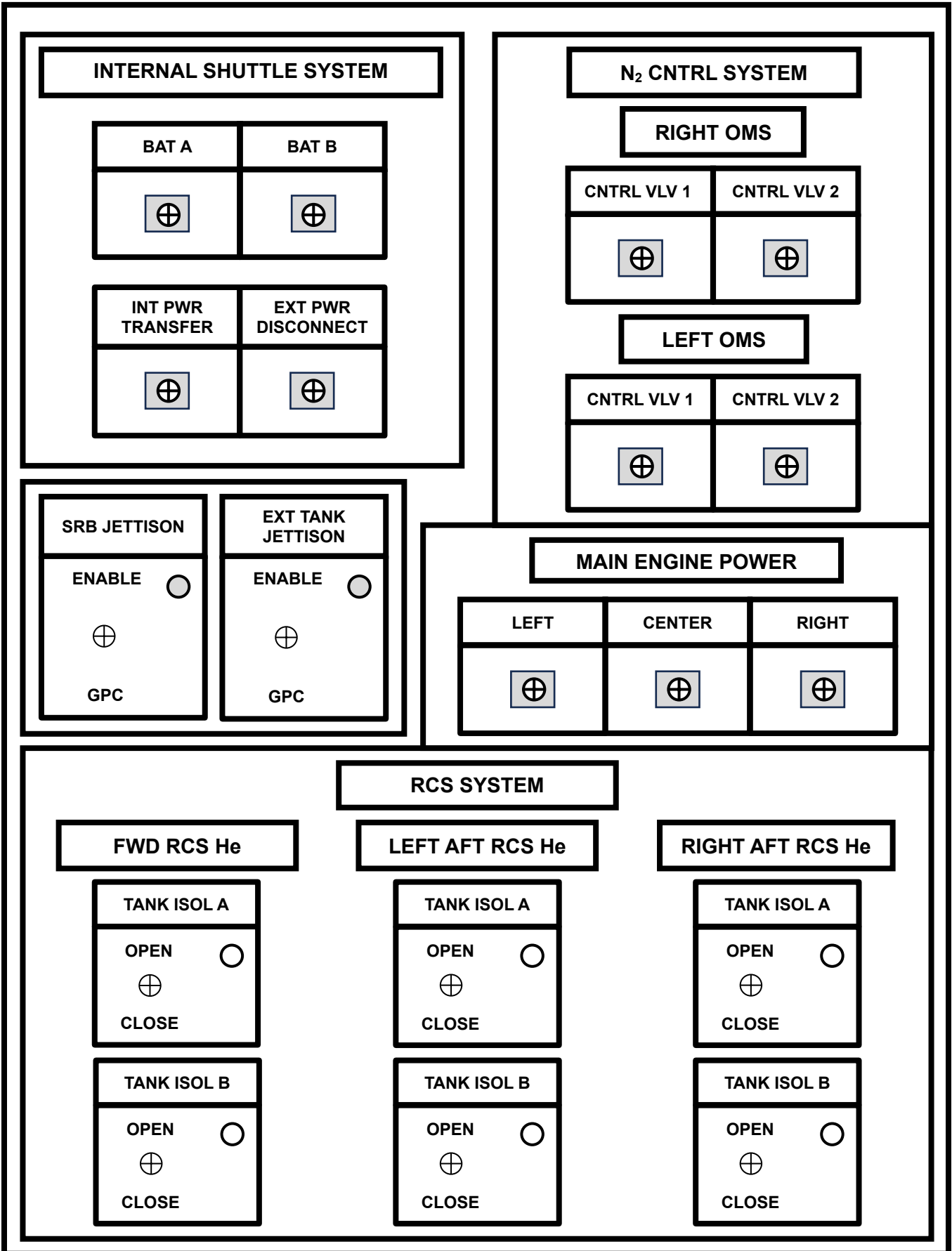

Orbiter Cockpit Panel 4

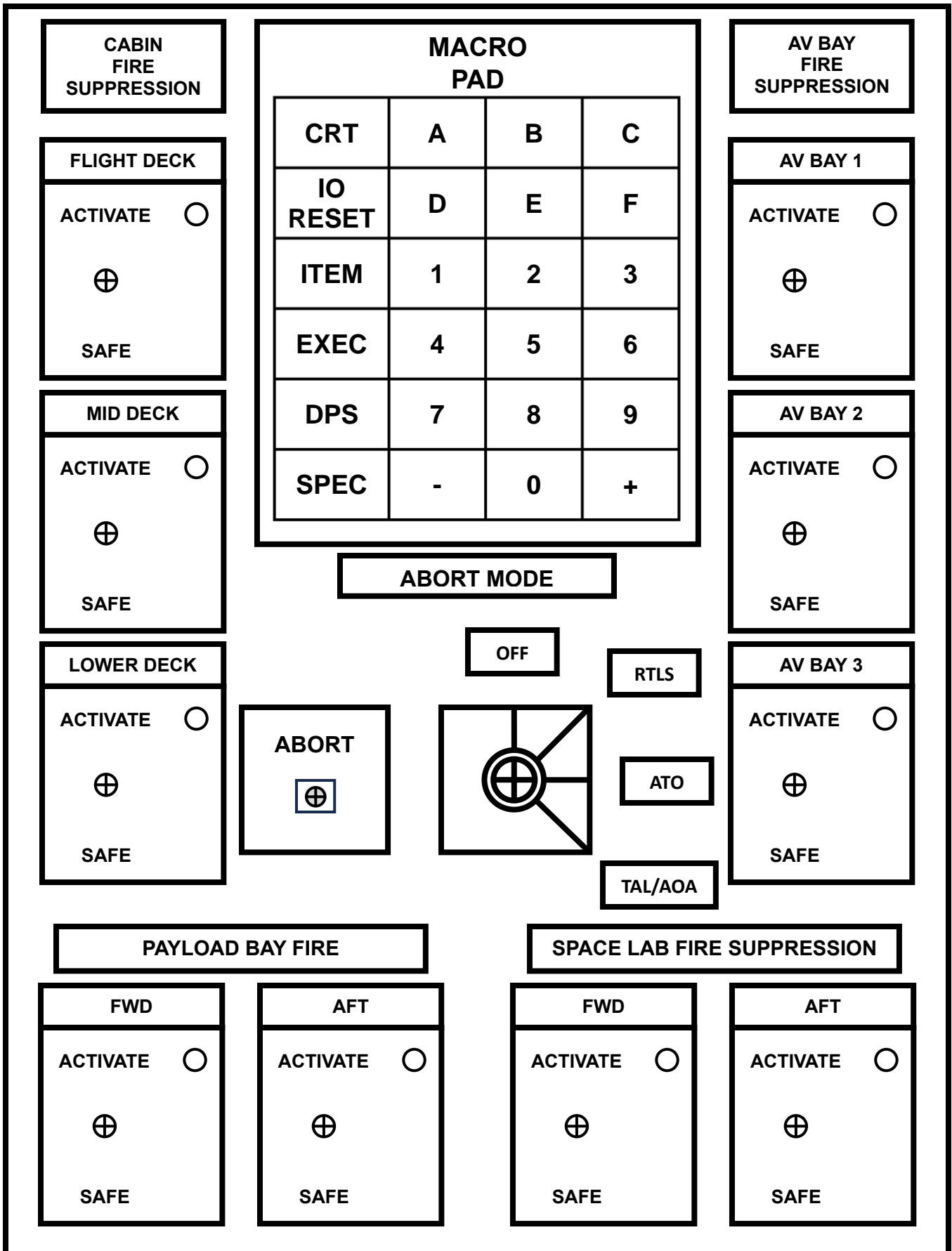

Orbiter Cockpit Panel 5

APU CNTRL POWER

1	2	3
ON <input type="radio"/>	ON <input type="radio"/>	ON <input type="radio"/>
⊕	⊕	⊕
OFF <input type="radio"/>	OFF <input type="radio"/>	OFF <input type="radio"/>

APU FUEL TANK VLV

1	2	3
OPEN <input type="radio"/>	OPEN <input type="radio"/>	OPEN <input type="radio"/>
⊕	⊕	⊕
CLOSE <input type="radio"/>	CLOSE <input type="radio"/>	CLOSE <input type="radio"/>

ENVIROMENTAL SYSTEM

O ₂ SYS	N ₂ SYS	H ₂ O LOOP
OPEN <input type="radio"/>	OPEN <input type="radio"/>	OPEN <input type="radio"/>
⊕	⊕	⊕
CLOSE <input type="radio"/>	CLOSE <input type="radio"/>	CLOSE <input type="radio"/>

BOILER CNTRL POWER

1	2	3
ON <input type="radio"/>	ON <input type="radio"/>	ON <input type="radio"/>
⊕	⊕	⊕
OFF <input type="radio"/>	OFF <input type="radio"/>	OFF <input type="radio"/>

THERMAL CONDITIONING SYSTEM

AIR HX	H ₂ O HX	FREON LOOP
OPEN <input type="radio"/>	OPEN <input type="radio"/>	OPEN <input type="radio"/>
⊕	⊕	⊕
CLOSE <input type="radio"/>	CLOSE <input type="radio"/>	CLOSE <input type="radio"/>

BOILER N₂ SUPPLY

1	2	3
OPEN <input type="radio"/>	OPEN <input type="radio"/>	OPEN <input type="radio"/>
⊕	⊕	⊕
CLOSE <input type="radio"/>	CLOSE <input type="radio"/>	CLOSE <input type="radio"/>

GLOBAL POSITIONING SYSTEM

1	2	3
ON <input type="radio"/>	ON <input type="radio"/>	ON <input type="radio"/>
⊕	⊕	⊕
OFF <input type="radio"/>	OFF <input type="radio"/>	OFF <input type="radio"/>

BOILER CNTRL HEATER

1	2	3
ON <input type="radio"/>	ON <input type="radio"/>	ON <input type="radio"/>
⊕	⊕	⊕
OFF <input type="radio"/>	OFF <input type="radio"/>	OFF <input type="radio"/>

Orbiter Cockpit Panel 6

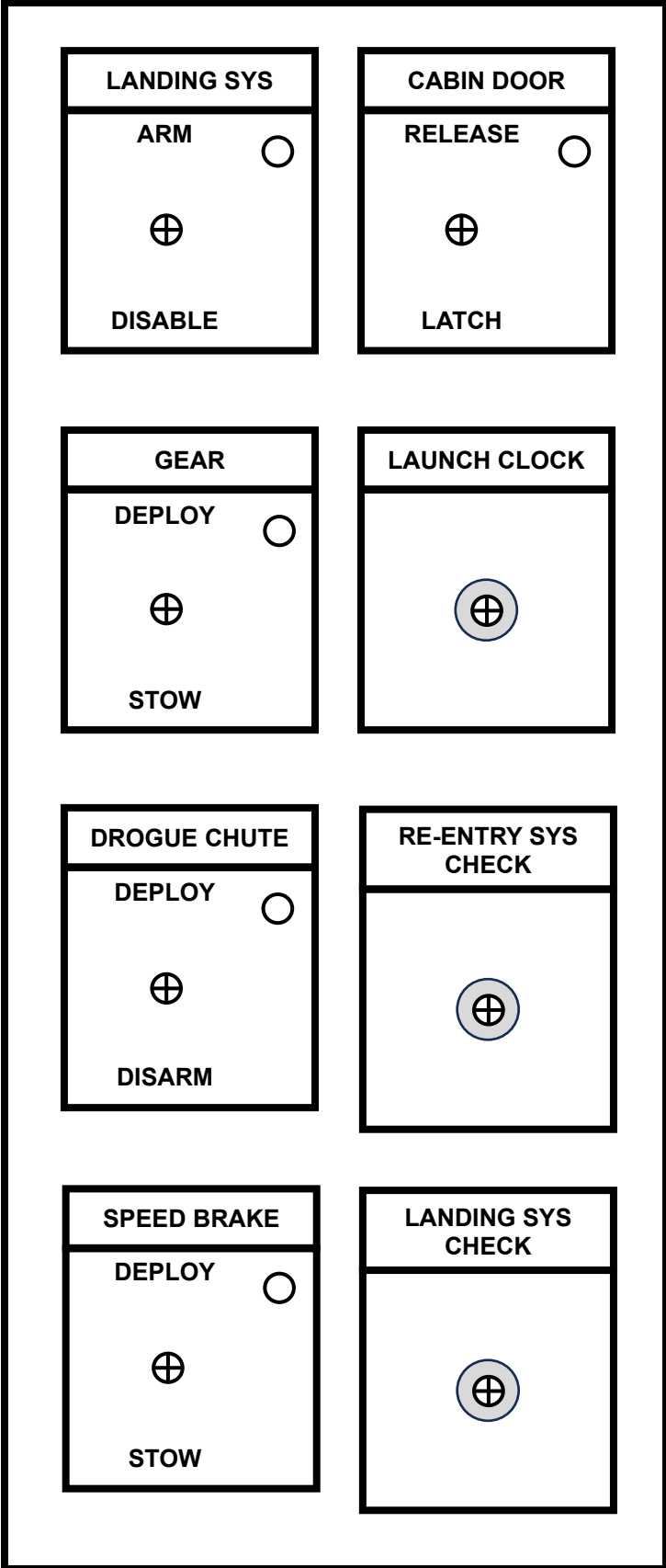

Flight Engineer Panel 7

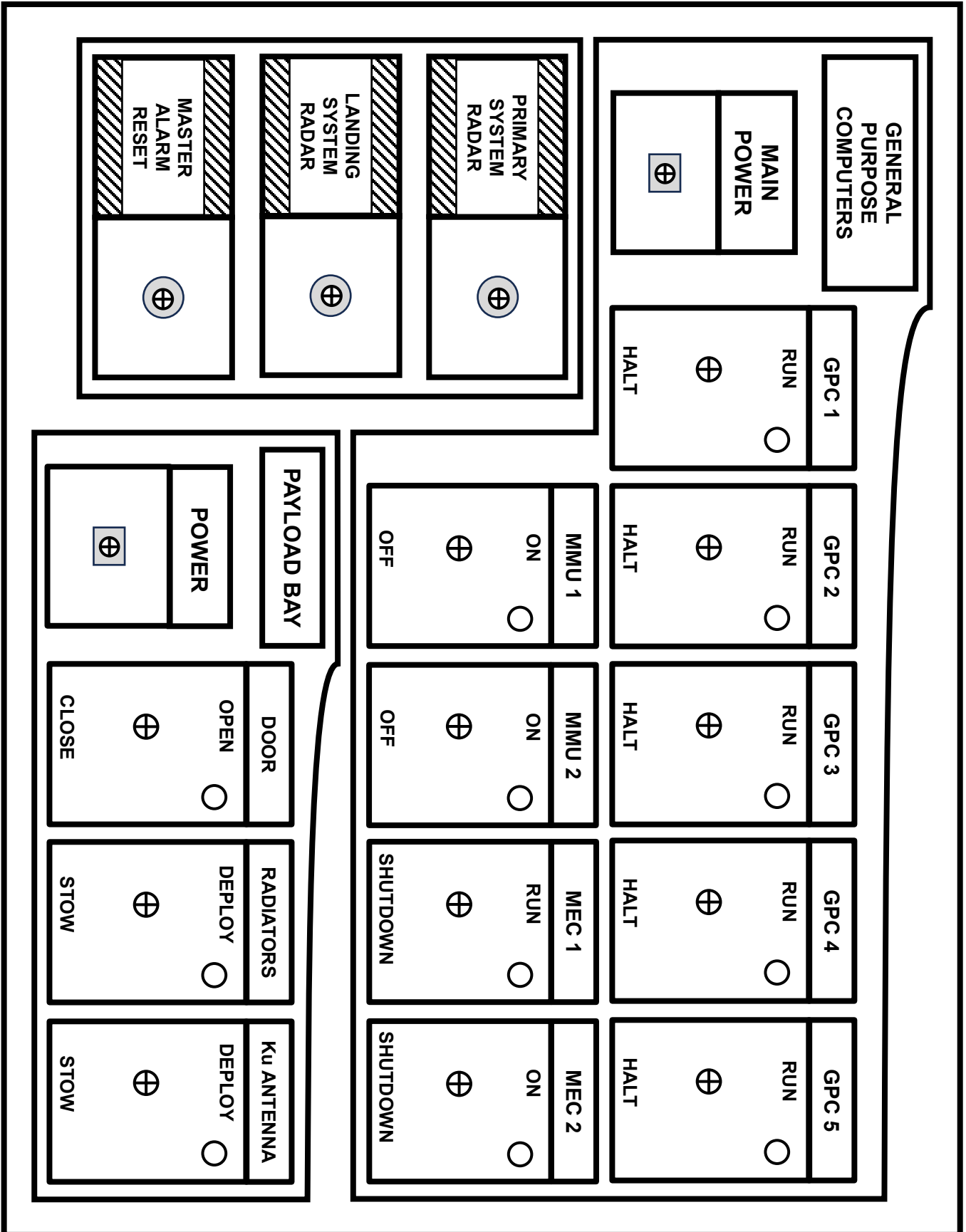

Flight Engineer Panel 8

Flight Engineer Panel 8 is a virtual switch panel with touch screen inputs.

To view and interact with this panel visit <https://shuttleswitches.com>

Example of virtual switch panel with Main Fuel Cutoff Valve open and all other valves closed

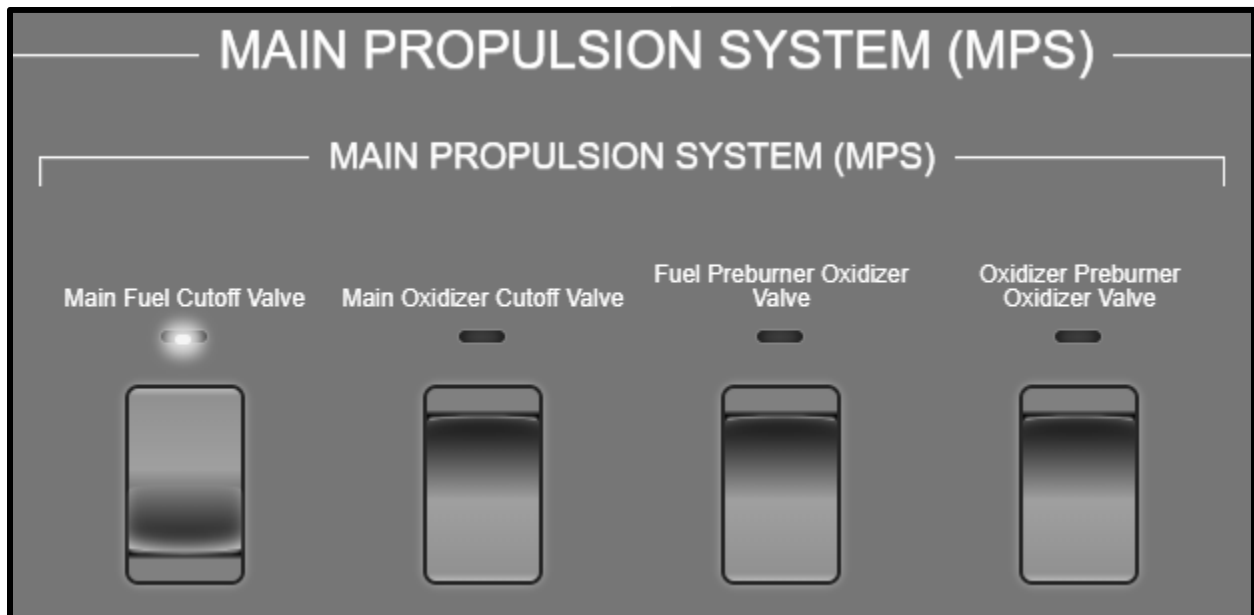

Flight Engineer Panel 9

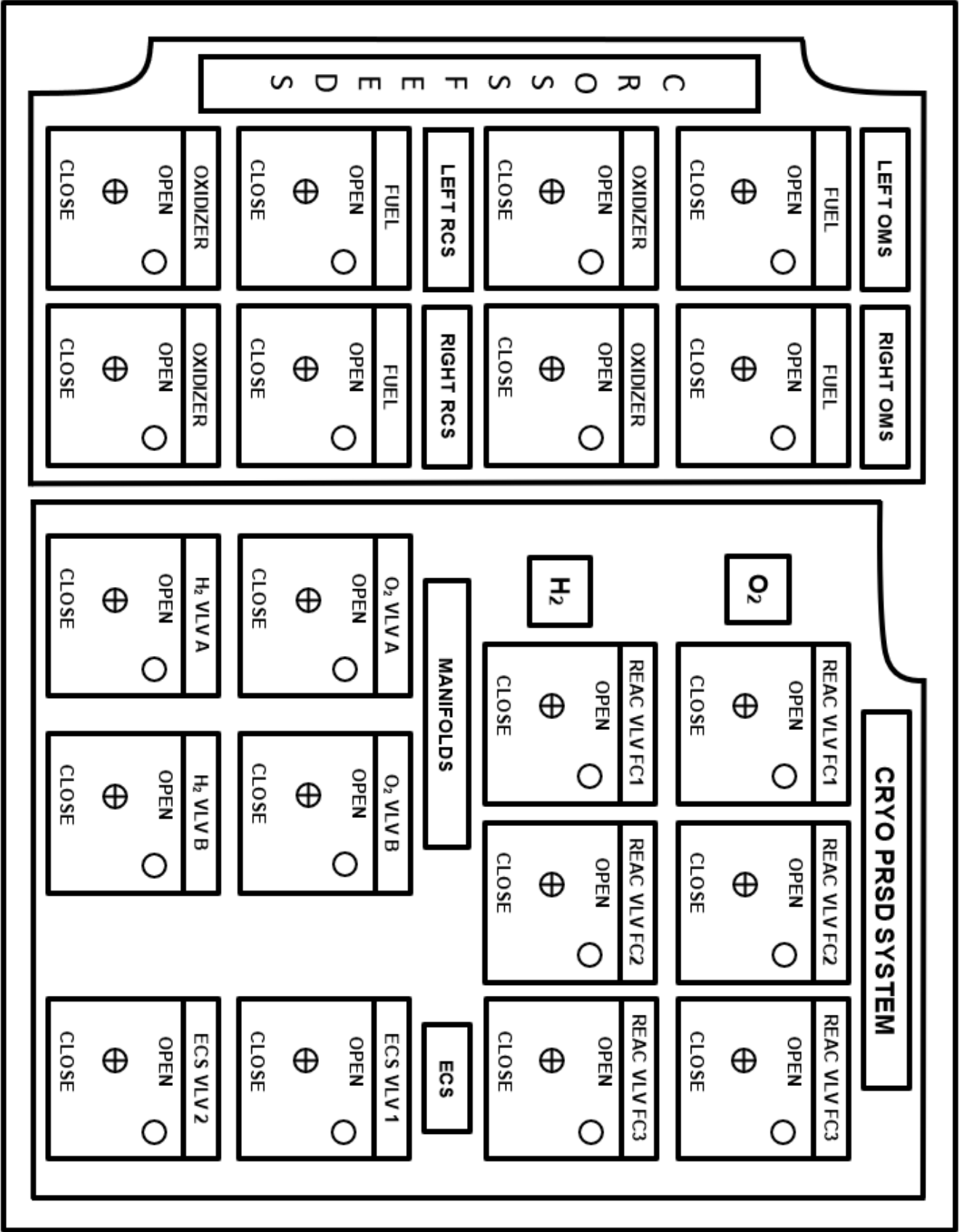

16 EMERGENCY CHECKLISTS

16.1 Introduction

The Emergency Procedures manual provides step-by-step resolutions to some common emergencies that can happen in any flight. To successfully resolve any emergency, the team must identify the system and sub-systems that are in an off-nominal condition using indicated data values and messages. Once the off-nominal systems are identified, the team needs to check the Emergency Procedures manual and determine if it covers the current emergency.

16.2 Emergency Checklist Operations

Using the Emergency Procedures manual:

- 1.** Verify the malfunctioning system(s) and only concentrate on those systems
- 2.** Run the checklist for just the malfunctioning system(s)
- 3.** Once a checklist is started, the crew must complete the entire checklist
- 4.** When the specific switch that resolves the issue is determined, the crew needs to remember which it is
- 5.** A suggestion is to mark the identified switch in some manner, like a rubber band or clip
- 6.** The last step of an emergency resolution should always be to have an “abort or not abort” discussion
- 7.** Once the emergency is resolved, the flight engineer needs to resume the flight at the checklist location the crew was at when the emergency occurred

EMERGENCY PROCEDURES DIRECTORY

NEGATIVE ORBIT INSERTION ABORT.....	109
LOW ORBIT INSERTION ABORT.....	109
IN ORBIT ABORT	109
RETURN TO LAUNCH SITE ABORT	109
APU UNDERSPEED	110
APU OVERSPEED.....	111
APU TEMPERATURE	112
HYDRAULIC PRESSURE	113
OMS ENGINE	114
AC VOLTAGE.....	114
FORWARD RCS.....	115
AFT RCS	115
MAIN ENGINES	116
SOLID ROCKET BOOSTERS	116
MALFUNCTION DURING PAYLOAD BAY DOOR OPEN PROCEDURE	117
MALFUNCTION DURING PAYLOAD BAY DOOR CLOSE PROCEDURE.....	118
SMOKE OR FIRE IN CABIN.....	119
SMOKE OR FIRE IN AV BAY	119
SMOKE OR FIRE IN PAYLOAD BAY	120
SMOKE OR FIRE IN SPACE LAB	120

Negative Orbit Insertion Abort

2A

1. Confirm Negative Orbit Insertion status with Mission Commander and Mission Director
2. Identify trajectory point for return:
 - A. Before Negative Return:
 - a. Perform Return To Launch Site (RTLS) abort
 - B. Post Negative Return:
 - a. If TAL window open:
 - Perform Transoceanic Abort Landing (TAL)
 - b. If TAL window closed:
 - Perform Abort Once Around (AOA)
3. Initiate abort procedures as indicated

Low Orbit Insertion Abort

2B

1. Confirm Abort To Orbit (ATO) status with Mission Commander and Mission Director
2. Evaluate orbital insertion status:
 - A. Lower stable orbit possible:
As directed by Mission Control:
 - a. Reconfigure for possible additional OMS burn

or

 - b. continue operations
 - B. Lower stable orbit not possible:
 - a. Perform Abort Once Around (AOA) as directed by Mission Control
3. Initiate abort procedures as indicated

In-Orbit Abort

2C

1. Confirm Abort status with Mission Commander and Mission Director
2. Initiate de-orbit burn procedures as directed by Mission Control

Return to Launch Site Abort

2D

1. Confirm Return to Launch Site Abort (RTLS) status with Mission Commander and Mission Director
2. Determine abort landing procedure options based on abort status:
 - a. KSC, East Coast Abort Landing location
 - b. Water landing
 - c. High altitude bailout
3. Initiate abort procedures as indicated

APU Underspeed

3

- | | |
|--|---|
| <p>1. Mission Control confirms alarm and proceeds with <u>isolation of malfunctioning system</u>.</p> <p>2. APU SPEED %</p> <p style="margin-left: 20px;">a. 1 Check</p> <p style="margin-left: 20px;">b. 2 Check</p> <p style="margin-left: 20px;">c. 3 Check</p> <p>3. APU SHUTDOWN ENABLE</p> <p>4. APU System Power Cycle</p> <p style="margin-left: 20px;">a. APU MAIN POWER OFF</p> <p style="margin-left: 20px;">b. APU MAIN POWER ON</p> <p>5. APU CNTRL POWER</p> <p style="margin-left: 20px;">a. 1 OFF</p> <p style="margin-left: 20px;">b. 2 OFF</p> <p style="margin-left: 20px;">c. 3 OFF</p> <p>6. APU / HYDRAULICS</p> <p style="margin-left: 20px;">a. 1 OFF</p> <p style="margin-left: 20px;">b. 2 OFF</p> <p style="margin-left: 20px;">c. 3 OFF</p> <p>7. APU SPEED SELECT</p> <p style="margin-left: 20px;">a. 1 GPC</p> <p style="margin-left: 20px;">b. 2 GPC</p> <p style="margin-left: 20px;">c. 3 GPC</p> <p>8. APU SPEED %</p> <p style="margin-left: 20px;">b. 1 Check</p> <p style="margin-left: 20px;">c. 2 Check</p> <p style="margin-left: 20px;">d. 3 Check</p> | <p>9. APU SPEED SELECT 1 HIGH</p> <p style="margin-left: 20px;">a. APU SPEED % 1 Check</p> <p style="margin-left: 20px;">b. APU SPEED SELECT 1 NORMAL</p> <p>10. APU SPEED SELECT 2 HIGH</p> <p style="margin-left: 20px;">a. APU SPEED % 2 Check</p> <p style="margin-left: 20px;">b. APU SPEED SELECT 2 NORMAL</p> <p>11. APU SPEED SELECT 3 HIGH</p> <p style="margin-left: 20px;">a. APU SPEED % 3 Check</p> <p style="margin-left: 20px;">b. APU SPEED SELECT 3 NORMAL</p> <p>12. APU / HYDRAULICS</p> <p style="margin-left: 20px;">a. 1 RUN</p> <p style="margin-left: 20px;">b. 2 RUN</p> <p style="margin-left: 20px;">c. 3 RUN</p> <p>13. APU CNTRL POWER</p> <p style="margin-left: 20px;">a. 1 ON</p> <p style="margin-left: 20px;">b. 2 ON</p> <p style="margin-left: 20px;">c. 3 ON</p> <p>14. APU SHUTDOWN INHIBIT</p> <p>15. APU SPEED %</p> <p style="margin-left: 20px;">a. 1 Check</p> <p style="margin-left: 20px;">b. 2 Check</p> <p style="margin-left: 20px;">c. 3 Check</p> <p>16. Re-assess system</p> |
|--|---|

APU Overspeed

4

1. Mission Control confirms alarm and proceeds with isolation of malfunctioning system.

2. APU SPEED %

- a. 1 Check
- b. 2 Check
- c. 3 Check

3. APU SHUTDOWN ENABLE

4. APU System Power Cycle

- a. APU MAIN POWER OFF
- b. APU MAIN POWER ON

5. APU CNTRL POWER

- a. 1 OFF
- b. 2 OFF
- c. 3 OFF

6. APU / HYDRAULICS

- a. 1 OFF
- b. 2 OFF
- c. 3 OFF

7. APU SPEED SELECT

- a. 1 GPC
- b. 2 GPC
- c. 3 GPC

8. APU SPEED %

- a. 1 Check
- b. 2 Check
- c. 3 Check

9. APU SPEED SELECT 1 NORMAL
 a. APU SPEED % 1 Check

10. APU SPEED SELECT 2 NORMAL
 a. APU SPEED % 2 Check

11. APU SPEED SELECT 3 NORMAL
 a. APU SPEED % 3 Check

12. APU / HYDRAULICS

- a. 1 RUN
- b. 2 RUN
- c. 3 RUN

13. APU CNTRL POWER

- a. 1 ON
- b. 2 ON
- c. 3 ON

14. APU SHUTDOWN INHIBIT

15. APU SPEED %

- a. 1 Check
- b. 2 Check
- c. 3 Check

16. Re-assess system

APU Temperature

5

1. Mission Control confirms alarm and proceeds with isolation of malfunctioning system.
2. APU EGT
 - a. 1 Check
 - b. 2 Check
 - c. 3 Check
3. APU SHUTDOWN ENABLE
4. APU System Power Cycle
 - a. APU MAIN POWER OFF
 - b. APU MAIN POWER ON
5. APU CNTRL POWER
 - a. 1 OFF
 - b. 2 OFF
 - c. 3 OFF
6. APU MASTER VLV..... CLOSE
7. APU FUEL TNK VLV
 - a. 1 CLOSE
 - b. 2 CLOSE
 - c. 3 CLOSE
8. APU EGT
 - a. 1 Check
 - b. 2 Check
 - c. 3 Check
9. APU FUEL TNK VLV
 - a. 1 OPEN
 - b. 2 OPEN
 - c. 3 OPEN

10. APU MASTER VLV OPEN
11. APU CNTRL POWER
 - a. 1 ON
 - b. 2 ON
 - c. 3 ON
12. APU SHUTDOWN INHIBIT
13. APU EGT
 - a. 1 Check
 - b. 2 Check
 - c. 3 Check
14. Re-assess system

Hydraulic Pressure

6

1. Mission Control confirms alarm and proceeds with isolation of malfunctioning system.
2. Hydraulic Pressure
 - a. 1 Check
 - b. 2 Check
 - c. 3 Check
3. HYD MAIN PUMP PRESSURE
 - a. 1 LOW
 - b. 2 LOW
 - c. 3 LOW
4. HYD CIRC PUMP
 - a. 1 OFF
 - b. 2 OFF
 - c. 3 OFF
5. APU / HYDRAULICS
 - a. 1 OFF
 - b. 2 OFF
 - c. 3 OFF
6. Hydraulic Pressure
 - a. 1 Check
 - b. 2 Check
 - c. 3 Check
7. APU / HYDRAULICS
 - a. 1 RUN
 - b. 2 RUN
 - c. 3 RUN

8. HYD CIRC PUMP
 - a. 1 ON
 - b. 2 ON
 - c. 3 ON
9. HYD MAIN PUMP PRESSURE
 - a. 1 NORMAL
 - b. 2 NORMAL
 - c. 3 NORMAL
10. Hydraulic Pressure
 - a. 1 Check
 - b. 2 Check
 - c. 3 Check
11. Re-assess system

OMS Engine

AC Voltage

7A

1. Mission Control confirms alarm and proceeds with isolation of malfunctioning system
2. FLT CNTRL PWR ENABLE
3. ENGINE DAP MANUAL
4. N₂ CNTRL VLV LEFT
 - a. 1 CLOSE
 - b. 2 CLOSE
5. N₂ CNTRL VLV RIGHT
 - c. 1 CLOSE
 - d. 2 CLOSE
6. Re-assess system
7. N₂ CNTRL VLV LEFT
 - a. 1 OPEN
 - b. 2 OPEN
8. N₂ CNTRL VLV RIGHT
 - a. 1 OPEN
 - b. 2 OPEN
9. ENGINE DAP AUTO
10. FLT CNTRL PWR INHIBIT
11. Re-assess system

7B

1. Mission Control confirms alarm and proceeds with isolation of malfunctioning system
2. AC BUS SNSR MONITOR
3. AC BUS
 - a. 1 OFF
 - b. 2 OFF
 - c. 3 OFF
4. INVERTER
 - a. 1 OFF
 - b. 2 OFF
 - c. 3 OFF
5. Re-assess system
6. INVERTER
 - a. 1 ON
 - b. 2 ON
 - c. 3 ON
7. AC BUS
 - a. 1 ON
 - b. 2 ON
 - c. 3 ON
8. AC BUS SNSR AUTO
9. Re-assess system

Forward RCS

8A

1. Mission Control confirms alarm and proceeds with isolation of malfunctioning system
2. FWD RCS He TANK ISOL
 - a. A CLOSE
 - b. B CLOSE
3. Re-assess system
4. FWD RCS He TANK ISOL
 - a. A OPEN
 - b. B OPEN
5. Re-assess system

Aft RCS

8B

1. Mission Control confirms alarm and proceeds with isolation of malfunctioning system
2. AFT RCS LEFT He TANK ISOL
 - a. A CLOSE
 - b. B CLOSE
3. AFT RCS RIGHT He TANK ISOL
 - a. A CLOSE
 - b. B CLOSE
4. Re-assess system
5. AFT RCS LEFT He TANK ISOL
 - a. A OPEN
 - b. B OPEN
6. AFT RCS RIGHT He TANK ISOL
 - a. A OPEN
 - b. B OPEN
7. Re-assess system

Main Engines

Solid Rocket Booster

9A

1. Mission Control confirms alarm and proceeds with isolation of malfunctioning system
2. Identify Main Engine Operational Status
 - a. Left Engine Check
 - b. Center Engine Check
 - c. Right Engine Check
3. Perform Manual Shutdown of Main Engine Power for Non-operating Engine identified in step 2

MAIN ENGINE POWER

- a. LEFT OFF
- b. CENTER OFF
- c. RIGHT OFF

4. Perform Manual Initialization of Main Engine Power for Non-operating Engine identified in step 2

MAIN ENGINE POWER

- a. LEFT ENABLE
- b. CENTER ENABLE
- c. RIGHT ENABLE

5. Re-assess system
6. Evaluate Status of Orbital Insertion
 - c. Positive Orbit Insertion Mission GO
 - d. Negative Orbit Insertion Go to Abort Checklist

9B

1. Mission Control confirms alarm
2. Identify SRB Operational Status
 - a. Left SRB Check
 - b. Right SRB Check
3. Evaluate Status of Orbital Insertion
 - a. Positive Orbit Insertion Mission GO
 - b. Negative Orbit Insertion Mission Abort
4. If Mission Go status
 - a. Monitor SRB operational status until SRB SEP
5. If Mission Abort status
 - a. Perform Emergency SRB Jettison
 - b. Execute RTLS Abort checklist

Malfunction during Payload Bay Door OPEN Procedure

10

Mission Control confirms alarm during Payload Bay Open Procedure

A. If alarm is on Payload Bay Door

1. PAYLOAD BAY DOOR CLOSE
2. PAYLOAD BAY POWER OFF
3. PAYLOAD BAY POWER ON
4. PAYLOAD BAY DOOR OPEN
5. Re-assess system

B. If alarm is on Radiators

1. RADIATORS STOW
2. PAYLOAD BAY POWER OFF
3. PAYLOAD BAY POWER ON
4. RADIATORS DEPLOY
5. Re-assess system

C. If alarm is on Ku Band Antenna

1. Ku ANTENNA STOW
2. PAYLOAD BAY POWER OFF
3. PAYLOAD BAY POWER ON
4. Ku ANTENNA DEPLOY
5. Re-assess system

Malfunction during Payload Bay Door CLOSE Procedure

11

Mission Control confirms alarm during Payload Bay CLOSE Procedure

A. If alarm is on Payload Bay Door

1. PAYLOAD BAY DOOR OPEN
2. PAYLOAD BAY POWER OFF
3. PAYLOAD BAY POWER ON
4. PAYLOAD BAY DOOR CLOSE
5. Re-assess system

B. If alarm is on Radiators

1. RADIATORS DEPLOY
2. PAYLOAD BAY POWER OFF
3. PAYLOAD BAY POWER ON
4. RADIATORS STOW
5. Re-assess system

C. If alarm is on Ku Band Antenna

1. Ku ANTENNA DEPLOY
2. PAYLOAD BAY POWER OFF
3. PAYLOAD BAY POWER ON
4. Ku ANTENNA STOW
5. Re-assess system

Smoke or Fire in Cabin

Smoke or Fire in AV Bay

12A

1. Mission Control confirms alarm and determines location
2. Visual inspection for smoke or fire
3. Cabin Temp Check
4. O2 SYS CLOSE
5. CABIN FIRE SUPPRESSION
 - a. FLIGHT DECK ACTIVATE
 - b. MID DECK ACTIVATE
 - c. LOWER DECK ACTIVATE
6. Cabin Temp Check
7. CABIN FIRE SUPPRESSION
 - a. FLIGHT DECK SAFE
 - b. MID DECK SAFE
 - c. LOWER DECK SAFE
8. O2 SYS OPEN
9. Land as soon as practical

12B

1. Mission Control confirms alarm and determines location
2. AV Bay
 - a. Temp 1 Check
 - b. Temp 2 Check
 - c. Temp 3 Check
3. AV BAY FIRE SUPPRESSION
 - a. AV BAY 1 ACTIVATE
 - b. AV BAY 2 ACTIVATE
 - c. AV BAY 3 ACTIVATE
4. AV Bay
 - a. Temp 1 Check
 - b. Temp 2 Check
 - c. Temp 3 Check
5. AV BAY FIRE SUPPRESSION
 - a. AV BAY 1 SAFE
 - b. AV BAY 2 SAFE
 - c. AV BAY 3 SAFE
6. Land as soon as practical

Smoke or Fire in Payload Bay

13A

1. Mission Control confirms alarm and determines location
2. Payload Bay
 - a. Forward Temp Check
 - b. Aft Temp Check
3. PAYLOAD BAY FIRE SUPPRESSION
 - a. FWD ACTIVATE
 - b. AFT ACTIVATE
4. Payload Bay
 - a. Forward Temp Check
 - b. Aft Temp Check
5. PAYLOAD BAY FIRE SUPPRESSION
 - a. FWD SAFE
 - b. AFT SAFE
6. Land as soon as practical

Smoke or Fire in Space Lab

13B

1. Mission Control confirms alarm and determines location
2. Space Lab
 - c. Forward Temp Check
 - d. Aft Temp Check
3. SPACE LAB FIRE SUPPRESSION
 - c. FWD ACTIVATE
 - d. AFT ACTIVATE
4. Space Lab
 - c. Forward Temp Check
 - d. Aft Temp Check
5. SPACE LAB FIRE SUPPRESSION
 - c. FWD SAFE
 - d. AFT SAFE
6. Land as soon as practical

17 VEHICLE SCHEMATICS

This Orbiter System Schematic Appendix can be used as a quick reference guide for Mission Control and Flight Teams. The schematics are listed in alphabetical order by system. The following system directory can be used to aid in locating specific systems as well as manually controlled system components.

System Schematic Directory

GENERAL OVERVIEW	123
VEHICLE STRUCTURE - ORBITER VEHICLE DIMENSIONS	123
ORBITER NOMINAL LAUNCH PROFILE	123
AUXILIARY POWER UNIT/HYDRAULICS (APU/HYD)	124
APU FUEL SYSTEM	124
WATER SPRAY BOILER SYSTEM	124
COMMUNICATIONS	125
S-BAND PM ANTENNA LOCATIONS.....	125
S-BAND FM ANTENNA LOCATIONS.....	125
KU-BAND DEPLOYED ASSEMBLY LOCATION	125
DATA PROCESSING SYSTEM (DPS)	126
GPS DATA BUS NETWORK	126
GENERAL PURPOSE COMPUTER FUNCTIONAL BLOCK DIAGRAM	127
ELECTRICAL POWER SYSTEM (EPS)	128
EPS OVERVIEW	128
PRSD CRYO SYSTEM	128
ELECTRICAL POWER DISTRIBUTION SCHEMATIC.....	129
DC MAIN BUS TIE BAR SCHEMATIC	129
DC POWER DISTRIBUTION	130
AC POWER DISTRIBUTION	131
ENVIRONMENTAL CONTROL AND LIFE SUPPORT SYSTEM (ECLSS)	132
ECLSS INTERFACES	
ECLSS LAYOUT	132
ECLSS OVERVIEW	132
.....	133
GUIDANCE, NAVIGATION, AND CONTROL (GNC)	133
INERTIAL MEASUREMENT UNIT	133
STAR TRACKER	134
MAIN PROPULSION SYSTEM (MPS)	134
MPS CRITICAL INTERFACES	134
MPS FILL AND DRAIN	135
ORBITER MAIN ENGINE	135
ORBITAL MANEUVERING SYSTEM (OMS)	136
OMS PROPELLANT FEED SYSTEM	136
OMS ENGINE	137
OMS NITROGEN SYSTEM	138

OMS HELIUM SYSTEM	138
OMS AND RCS CROSSFEED VALVES	139
REACTION CONTROL SYSTEM (RCS)	140
FORWARD RCS SCHEMATIC	140
AFT RCS SCHEMATIC	141
RCS PRIMARY JET	142
RCS VERNIER JET	142
RCS JET LOCATION SCHEMATIC.....	143
ASCENT PROFILE WITH OMS AND RCS OPERATIONS	143

GENERAL OVERVIEW

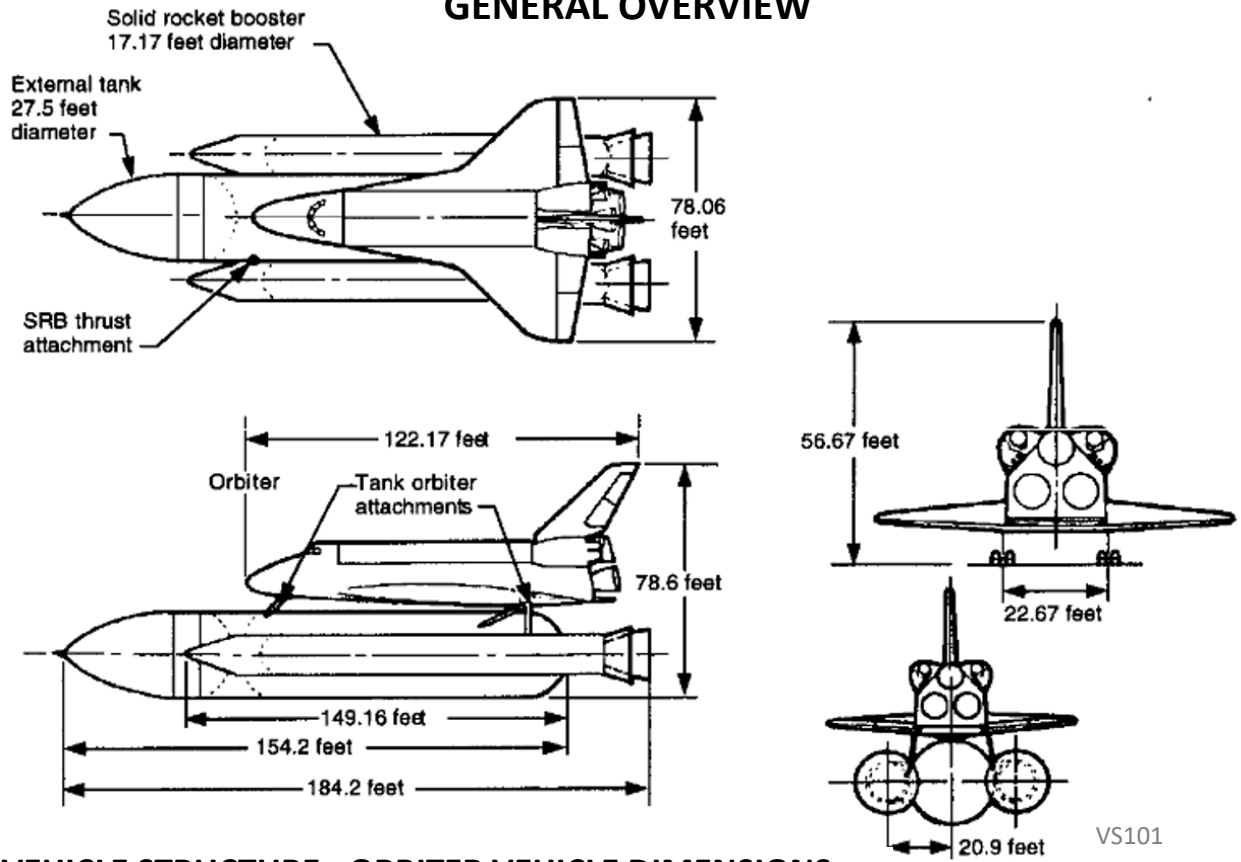

VS101

VEHICLE STRUCTURE - ORBITER VEHICLE DIMENSIONS

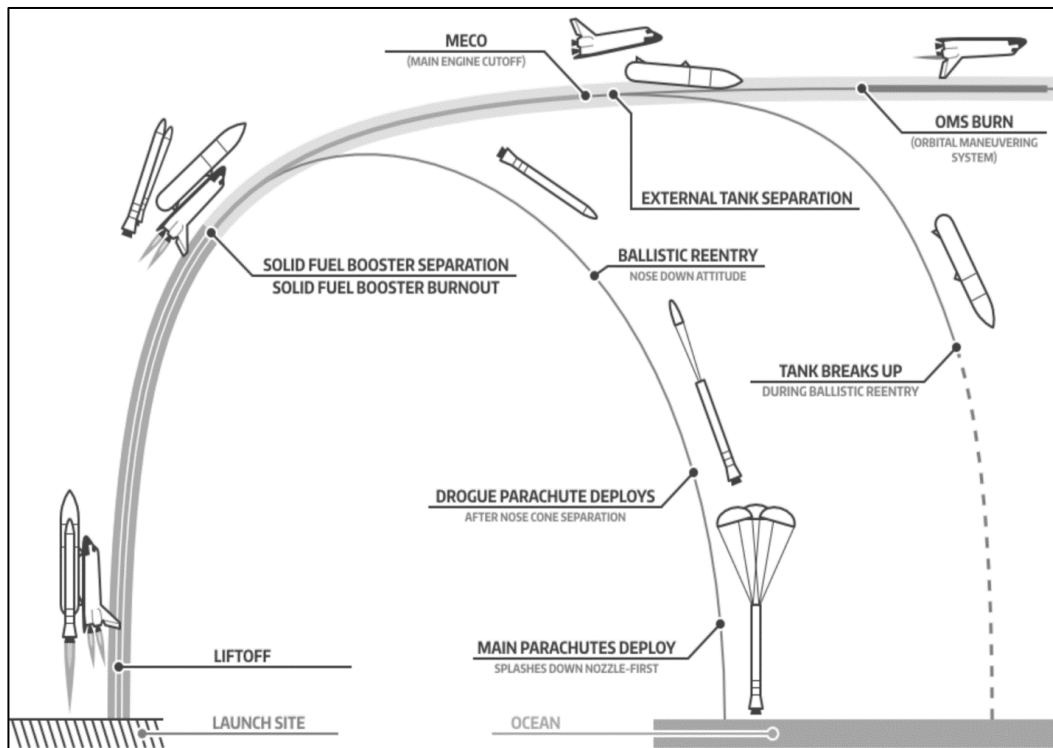

ORBITER NOMINAL LAUNCH PROFILE

VS102

AUXILIARY POWER UNIT/HYDRAULICS (APU/HYD)

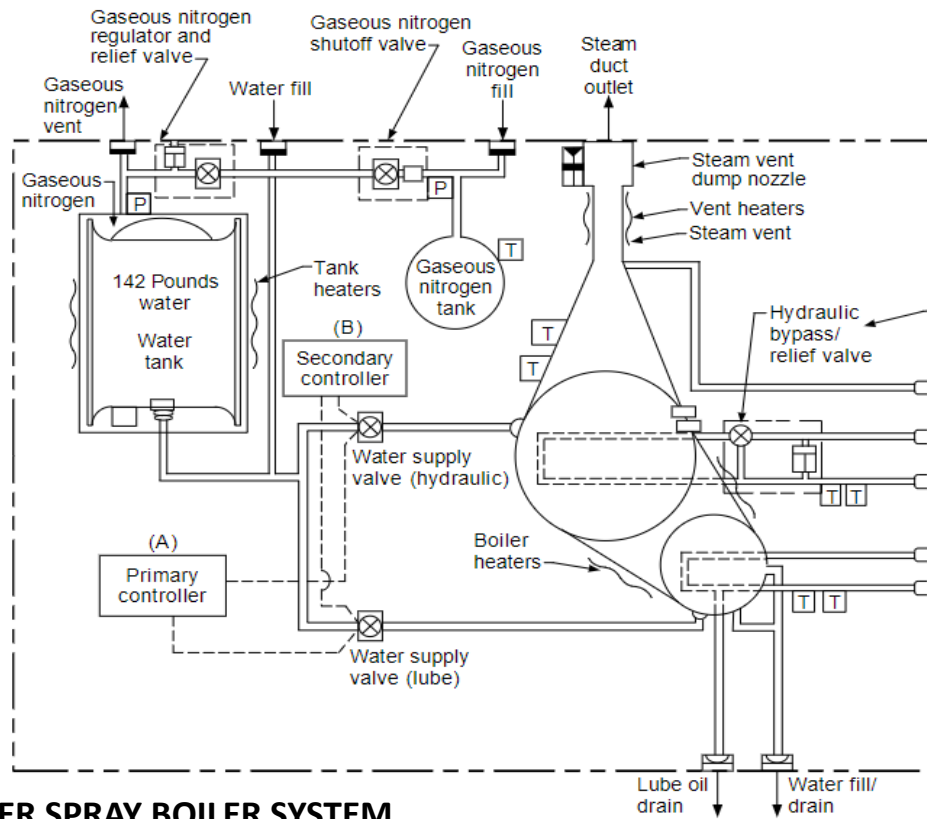
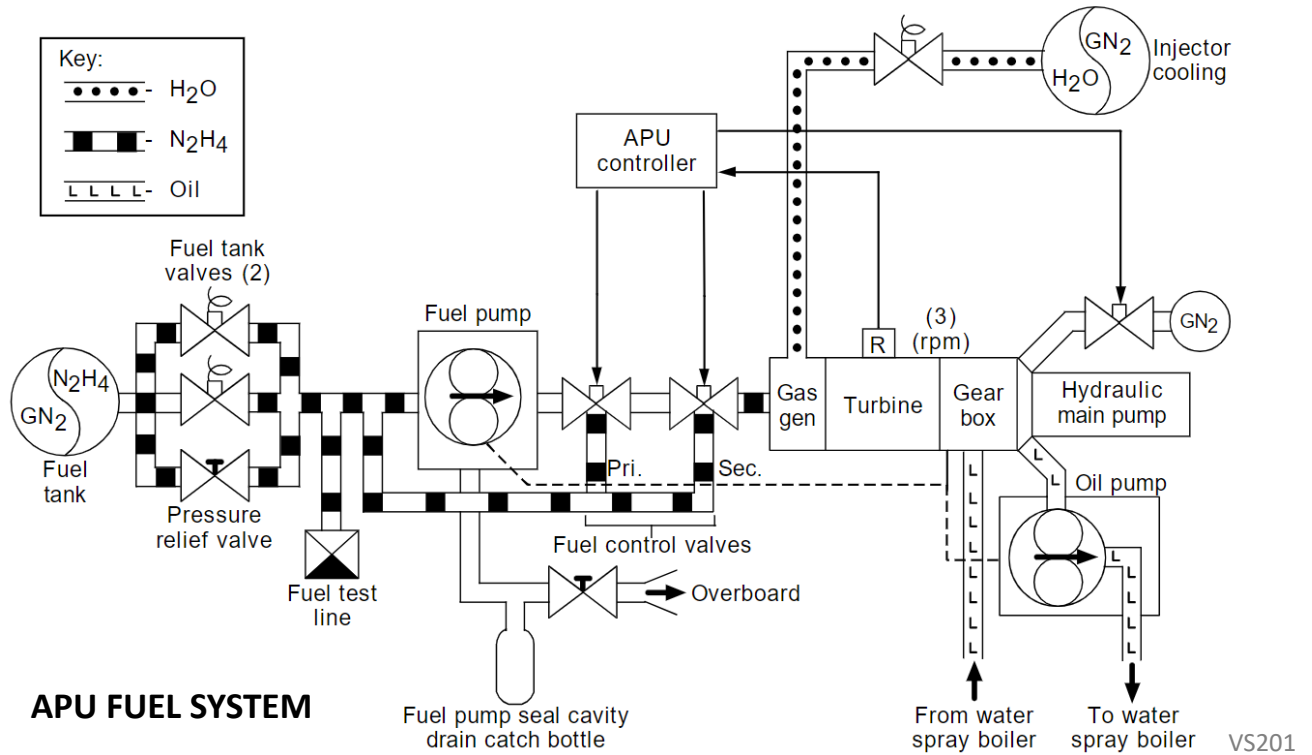

COMMUNICATIONS

S-BAND PM ANTENNA

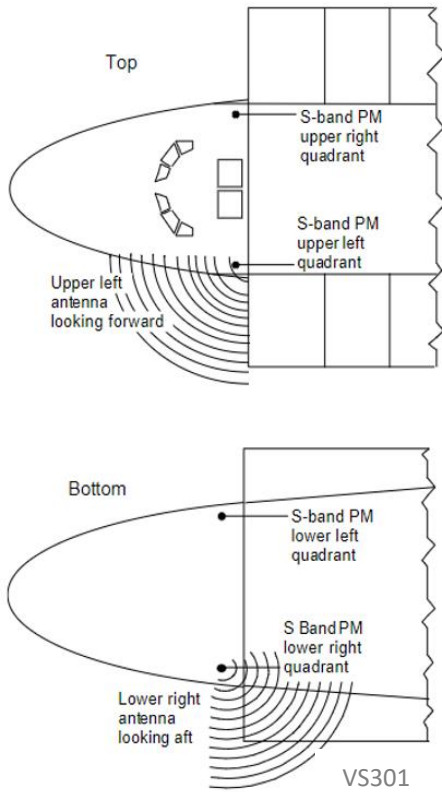

S-BAND FM ANTENNA

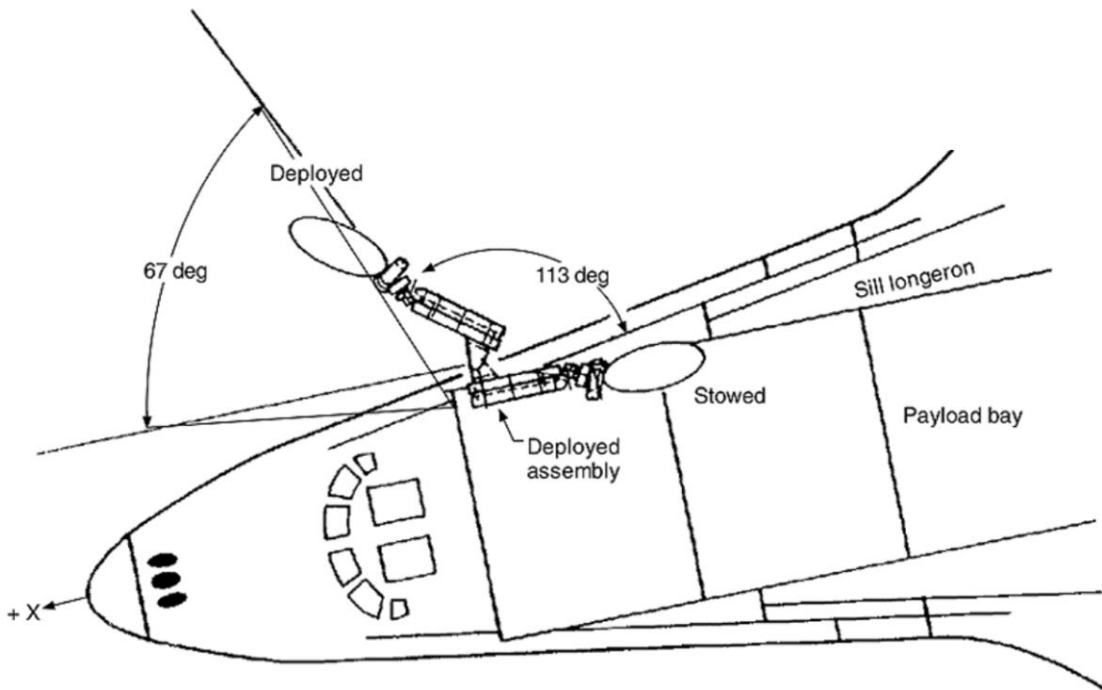
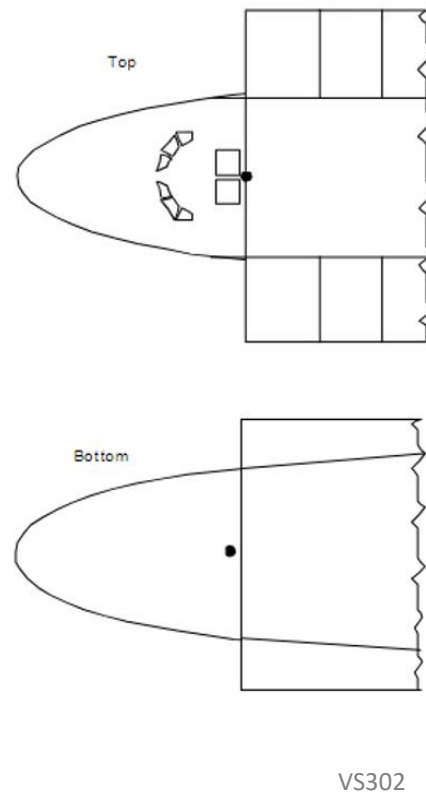

Ku-BAND DEPLOYED ASSEMBLY LOCATION

VS303

DATA PROCESSING SYSTEM (DPS)

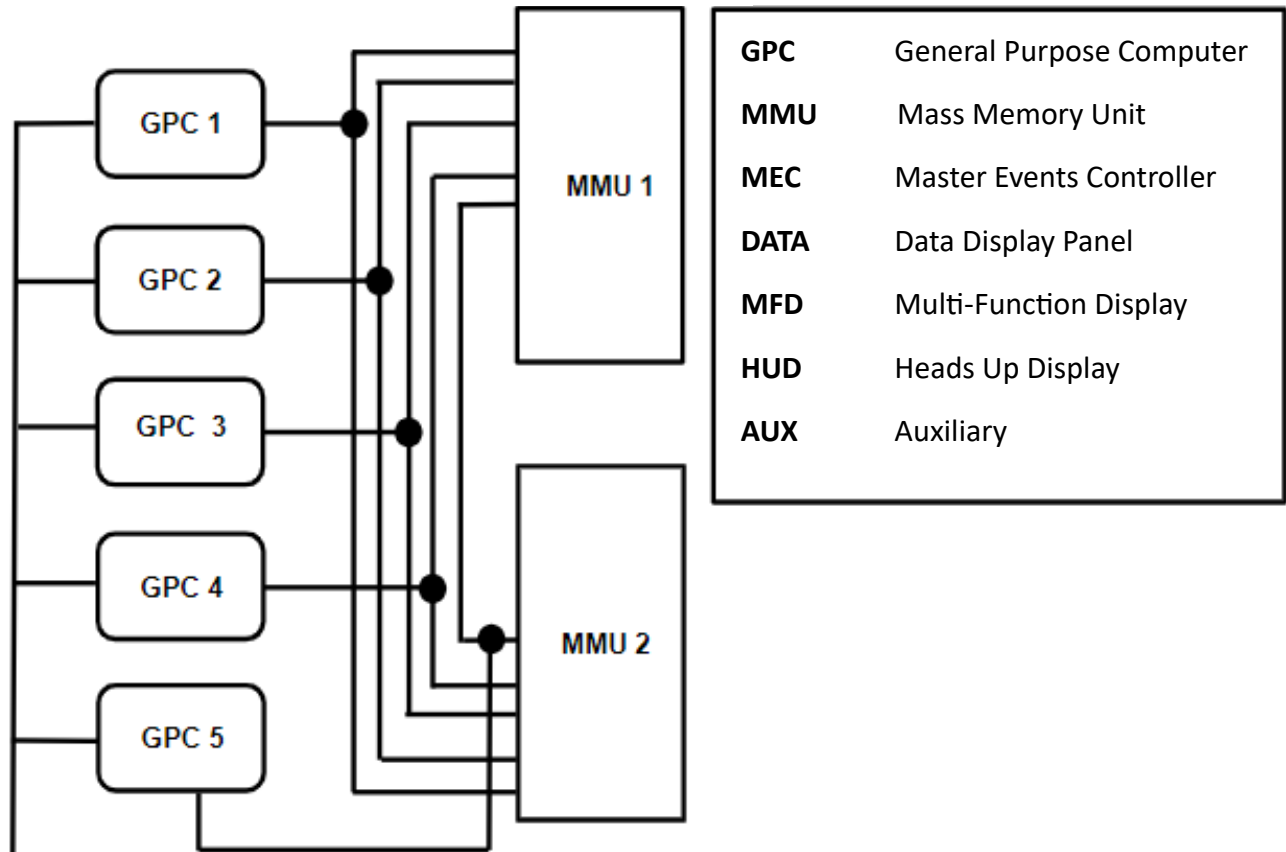

GPC	General Purpose Computer
MMU	Mass Memory Unit
MEC	Master Events Controller
DATA	Data Display Panel
MFD	Multi-Function Display
HUD	Heads Up Display
AUX	Auxiliary

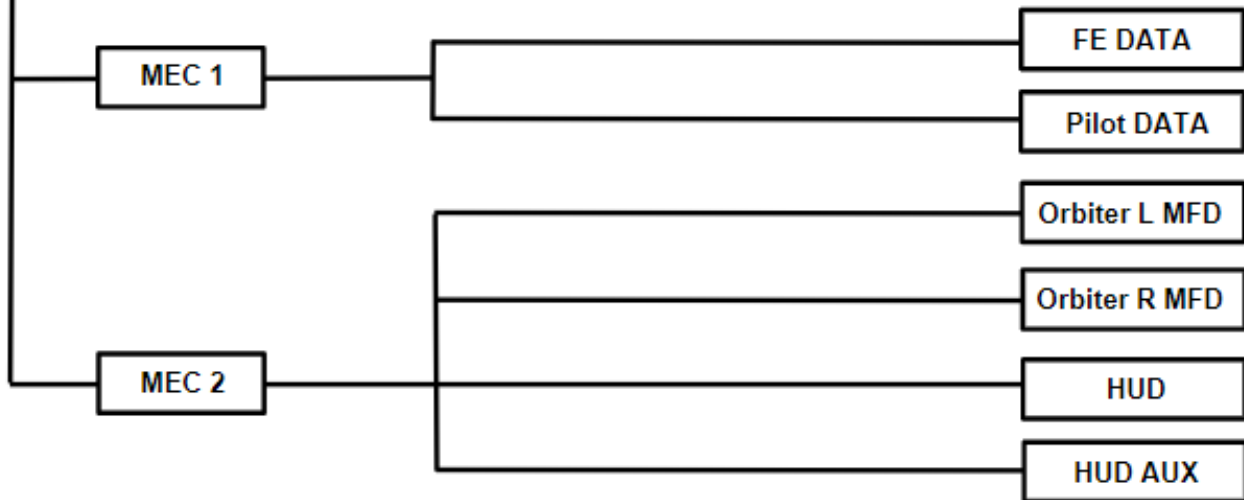

GPS DATA BUS NETWORK

VS401

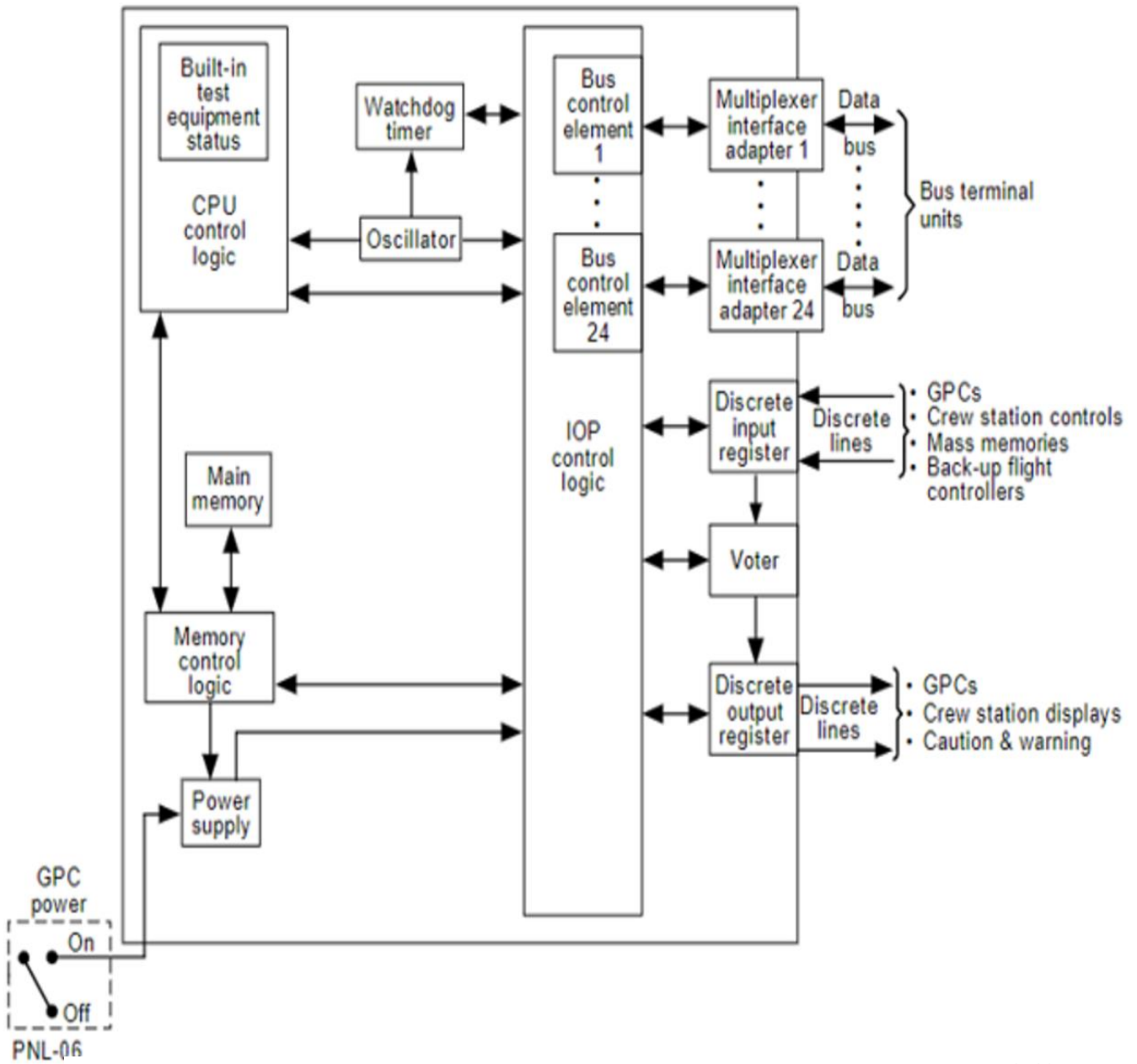

GENERAL PURPOSE COMPUTER FUNCTIONAL BLOCK DIAGRAM

VS402

ELECTRICAL POWER SYSTEM (EPS)

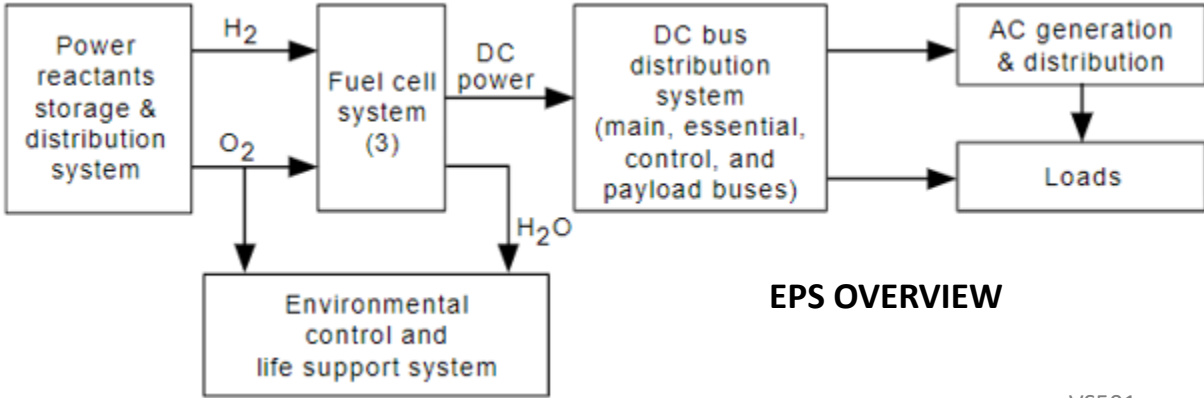

EPS OVERVIEW

VS501

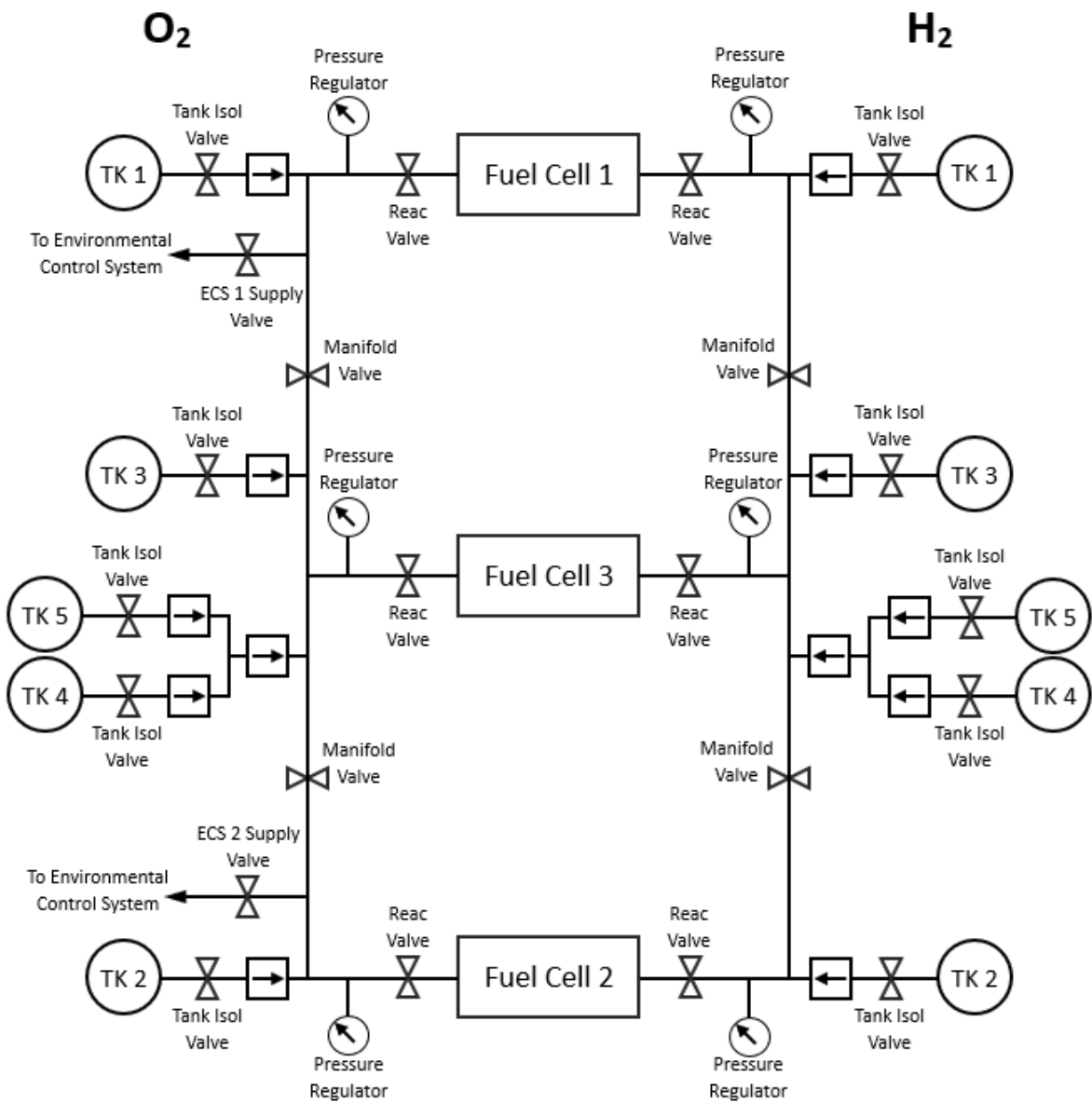

PRSD CRYO SYSTEM

VS502

ELECTRICAL POWER DISTRIBUTION SCHEMATIC

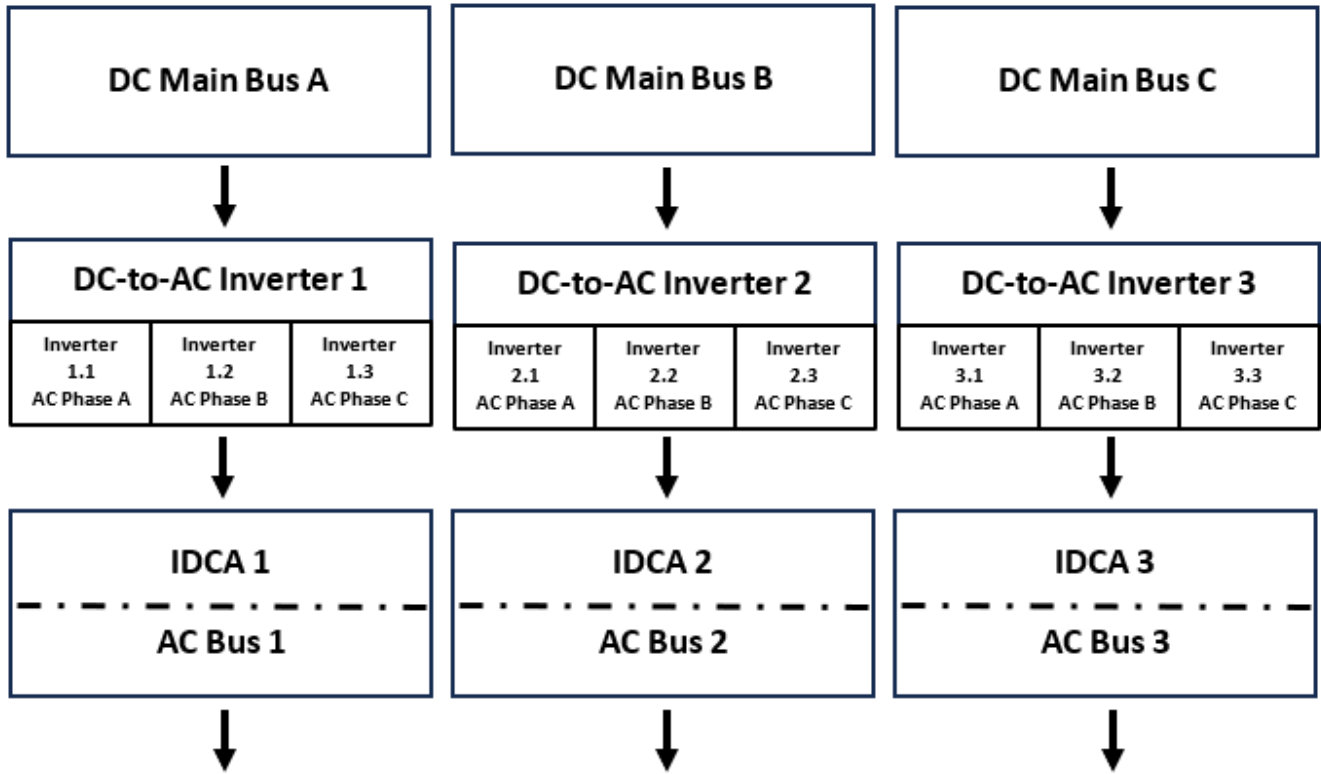

VS503

DC MAIN BUS TIE BAR SCHEMATIC

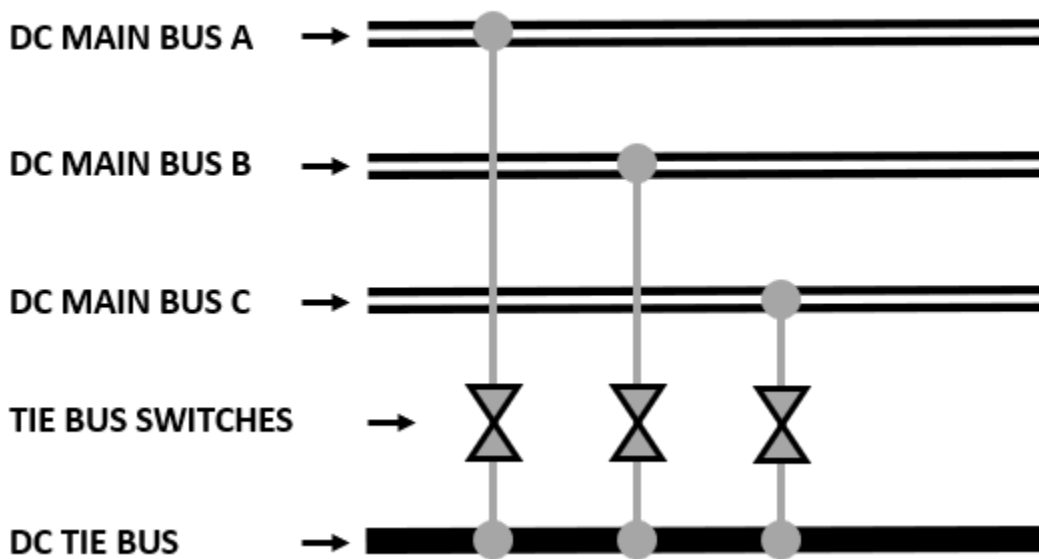

VS504

DC POWER DISTRIBUTION

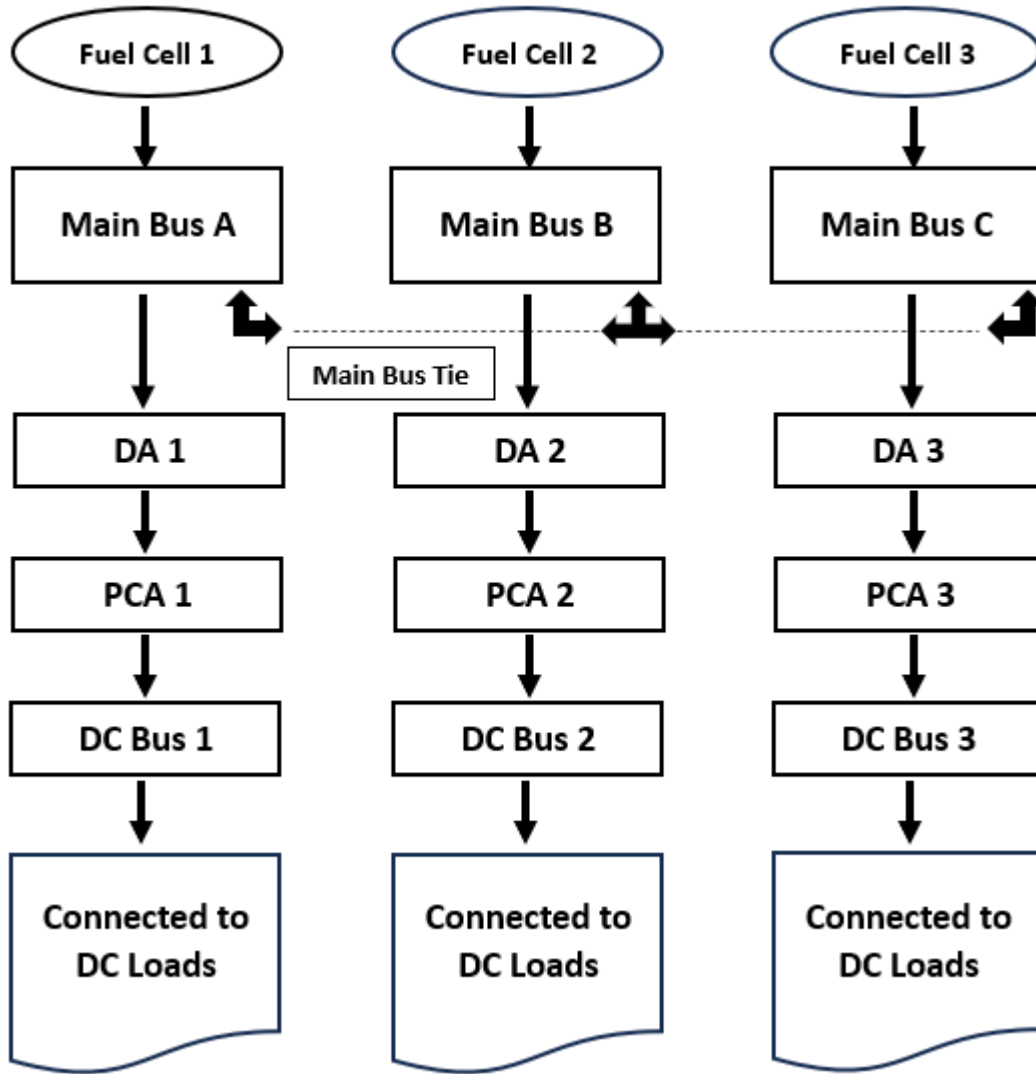

<p>DC Bus 1: control loads include:</p> <ol style="list-style-type: none"> 1) Flight Deck Power Panels 2) Primary Systems Control 3) Forward Remote Power Relays <ol style="list-style-type: none"> a) Master Relay b) Fwd L/R Vent Doors c) Star Tracker Y/Z Doors d) Air Data L/R Doors e) Fwd RCS Manifold Valves f) Fwd RCS Tank Isol valves 	<p>DC Bus 2: control loads include:</p> <ol style="list-style-type: none"> 1) Mid Deck Power Panels 2) Secondary Systems Control 3) Mid Remote Power Relays <ol style="list-style-type: none"> a) Master Relay b) Mid L/R Vent Doors c) Payload Bay Doors d) Payload Bay Door Latches e) Payload Bay Retention Latches f) Radiator Deployment Actuators 	<p>DC Bus 3: control loads include:</p> <ol style="list-style-type: none"> 1) Aft Power Panels 2) Aft Remote Power Relays <ol style="list-style-type: none"> a) Master Relay b) Aft Vent Doors c) Aft OMS/RCS Manifold Valves d) Aft OMS/RCS Tank Isol Valves e) Aft OMS/RCS Crossfeed Valves
---	--	--

AC POWER DISTRIBUTION

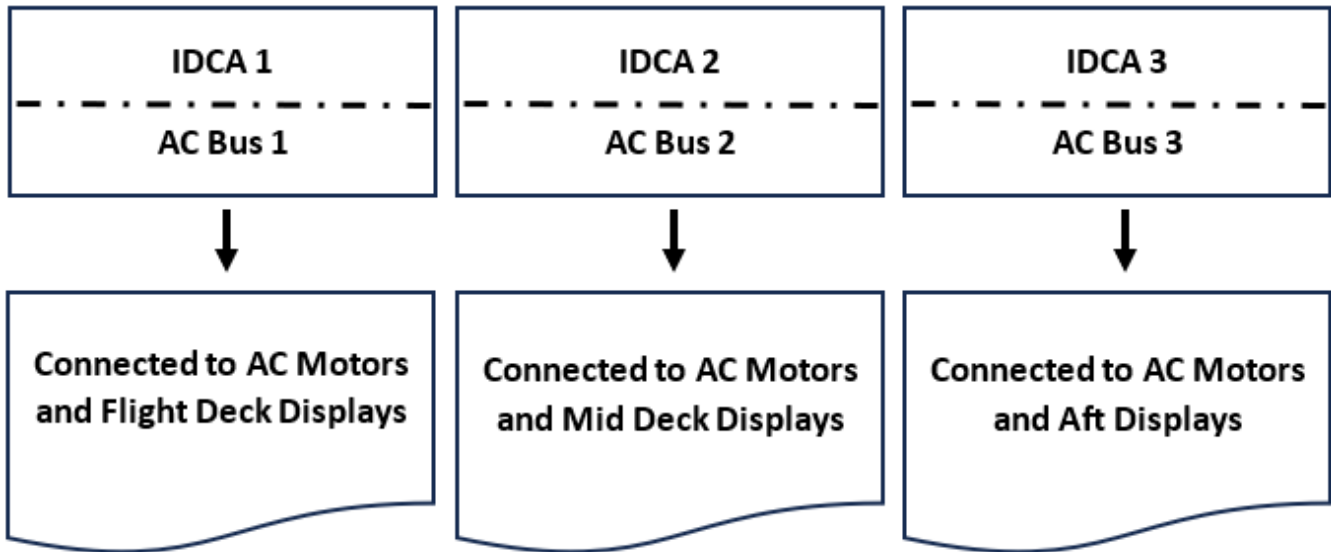

<p>AC Bus 1: control loads include:</p> <ol style="list-style-type: none"> 1) Primary Avionics 2) Forward L/R Vent Doors 3) Star Tracker Y/Z Doors 4) L/R Air Data Doors 5) Forward RCS Manifold Valves 6) Forward RCS Tank Isol Valves 	<p>AC Bus 2: control loads include:</p> <ol style="list-style-type: none"> 1) Mid L/R Vent Doors 2) Payload Bay Doors 3) Payload Bay Door Latches 4) Bay Retention Latches 5) Radiator Deploy Actuators 	<p>AC Bus 3: control loads include:</p> <ol style="list-style-type: none"> 1) Secondary Avionics 2) Aft Vent Doors 3) Aft OMS/RCS Manifold Valve 4) Aft OMS/RCS Tank Isol Valves 5) Aft OMS/RCS Crossfeed Valves
--	---	--

VS506

ENVIRONMENTAL CONTROL and LIFE SUPPORT SYSTEM (ECLSS)

- | | |
|---|---|
| 1 Water coolant loops | 17 Inertial measurement units heat exchanger and fans |
| 2 Interchanger heat exchanger | 18 Water pumps |
| 3 Payload heat exchanger | 19 Cabin air to water heat exchanger |
| 4 Freon-21 coolant loops | 20 Humidity water separators |
| 5 Fuel cell power plants | 21 Carbon dioxide absorber |
| 6 Cargo heat exchanger | 22 Cabin fans and check valve assemblies |
| 7 Hydraulic heat exchangers to radiators | 23 Liquid-cooled garment heat exchanger |
| 8 Aft avionics bay and cold plates | 24 Potable water chiller heat exchanger |
| 9 Ground support equipment heat exchanger | |
| 10 Flash evaporators | |
| 11 Ammonia boiler | |
| 12 To radiators | |
| 13 Midbody cold plates | |
| 14 Fuel cell heat exchanger to Freon-21 coolant loops | |
| 15 Freon-21 coolant pumps | |
| 16 Avionics bays 1, 2, and 3A heat exchangers, fans, and coolant plants | |

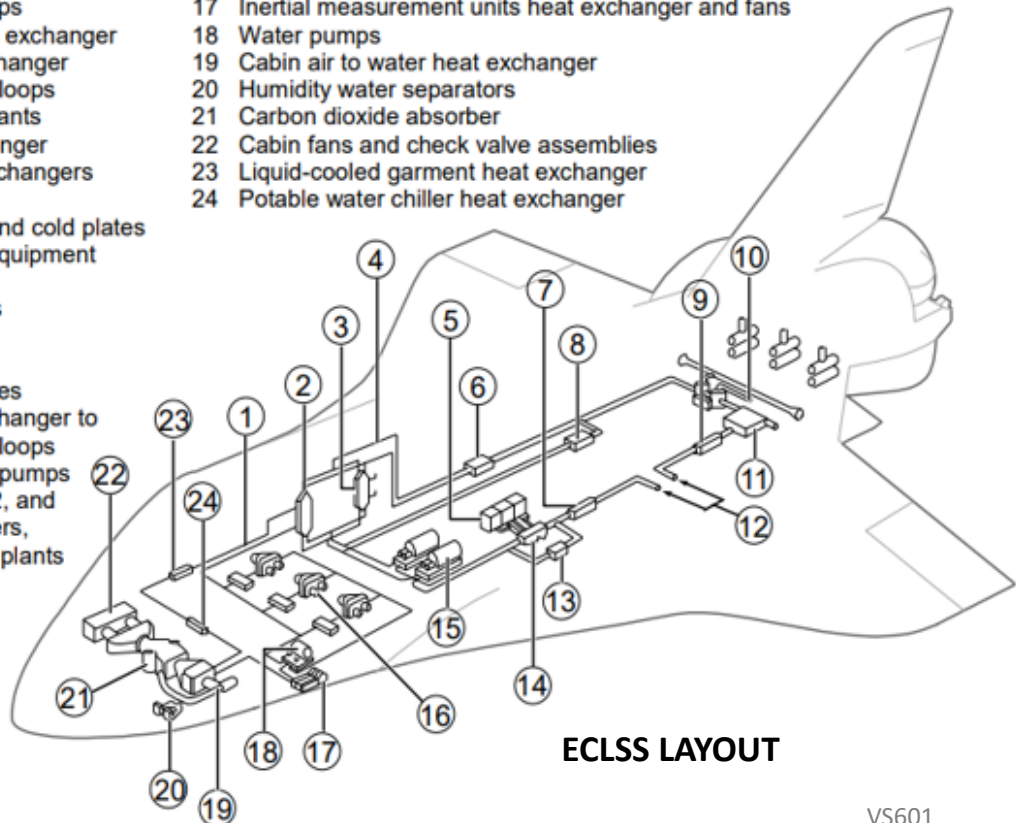

ECLSS LAYOUT

VS601

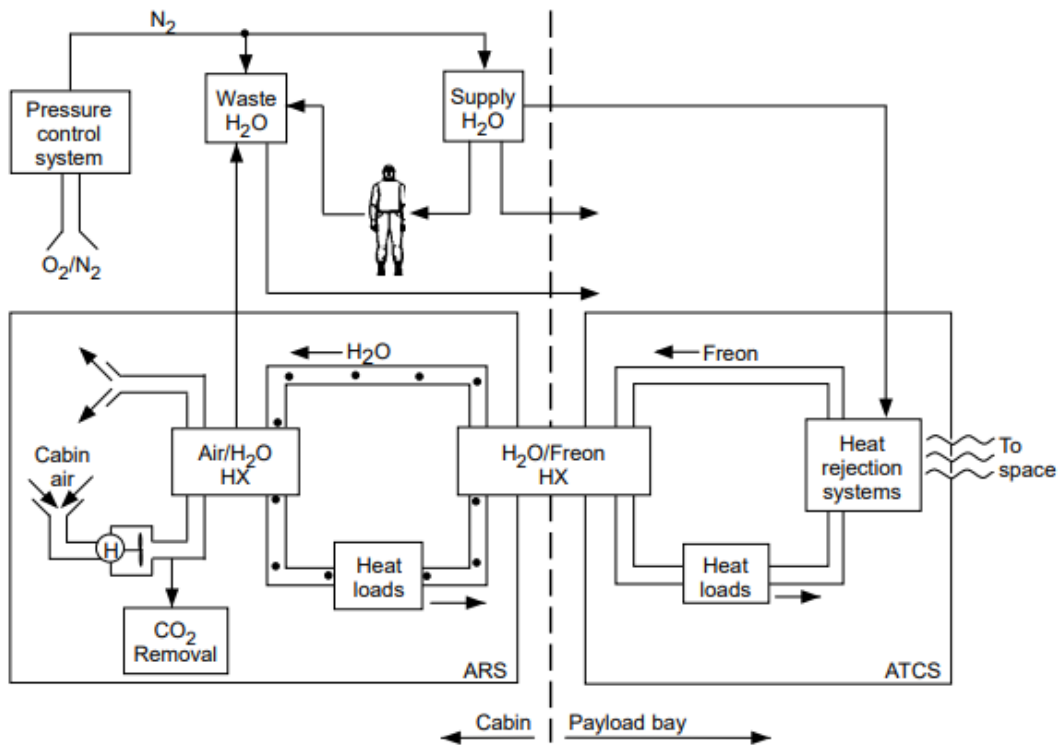

ECLSS OVERVIEW

VS602

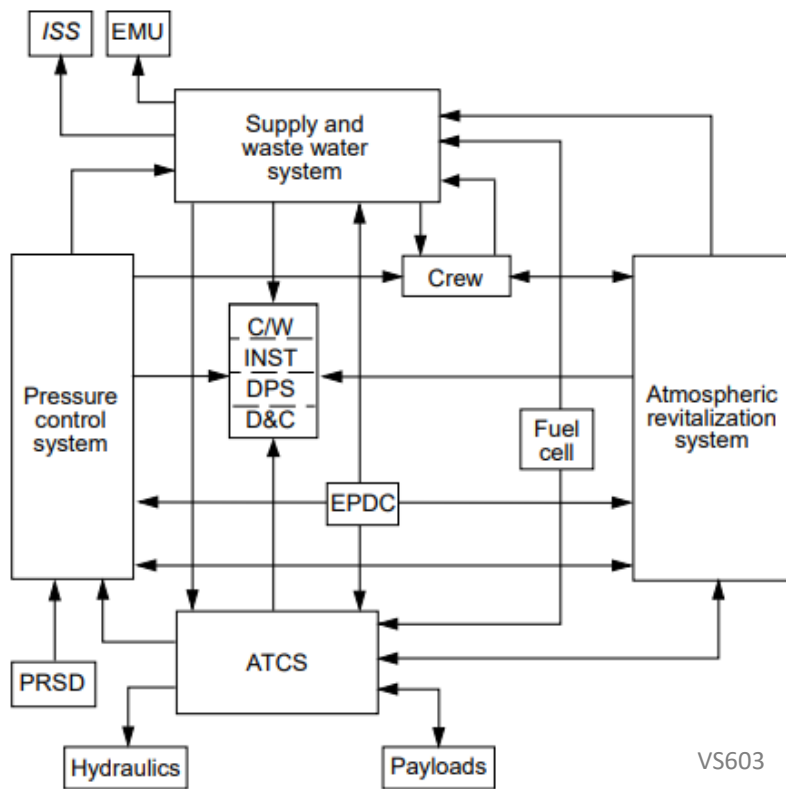

VS603

ECLSS INTERFACES

GUIDANCE, NAVIGATION, and CONTROL (GNC)

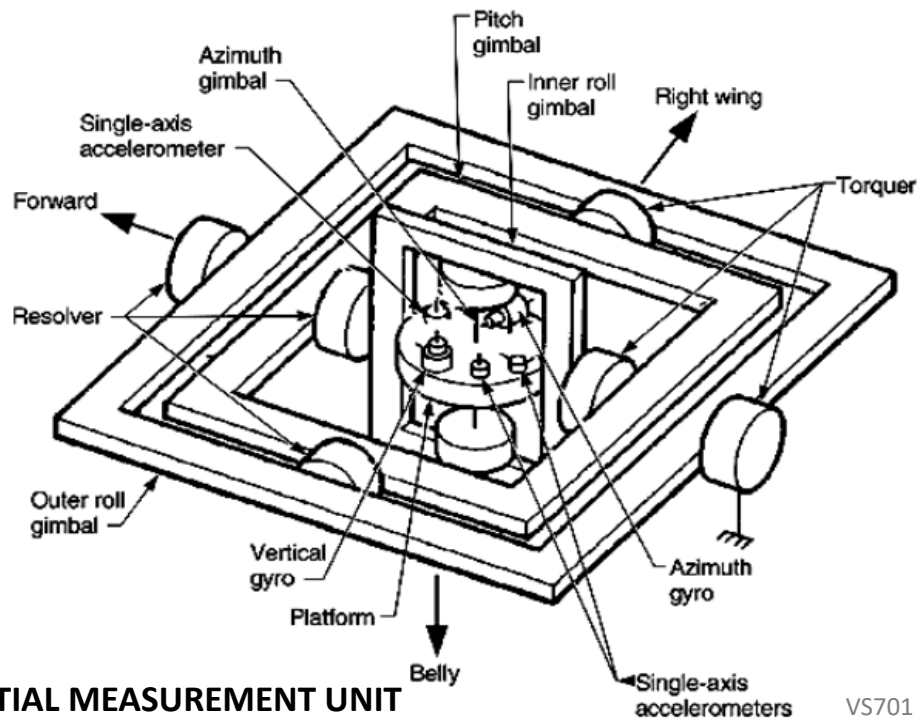

INERTIAL MEASUREMENT UNIT

VS701

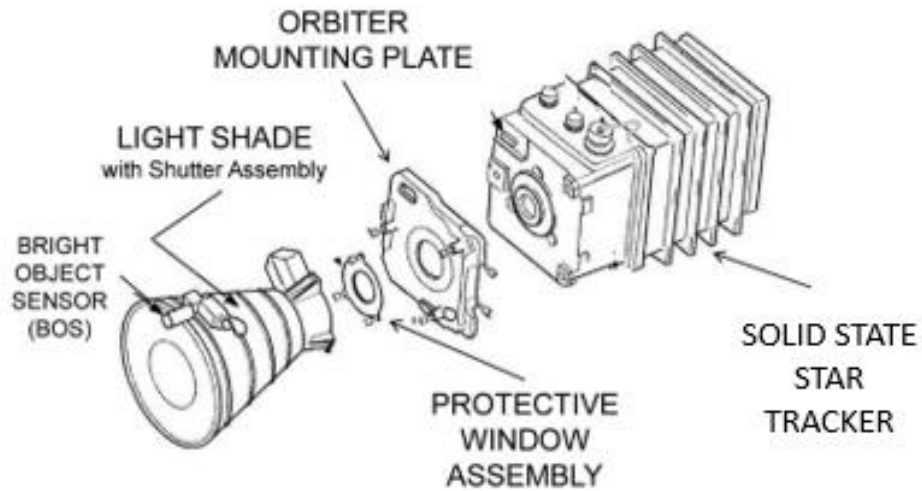

STAR TRACKER

VS702

MAIN PROPULSION SYSTEM (MPS)

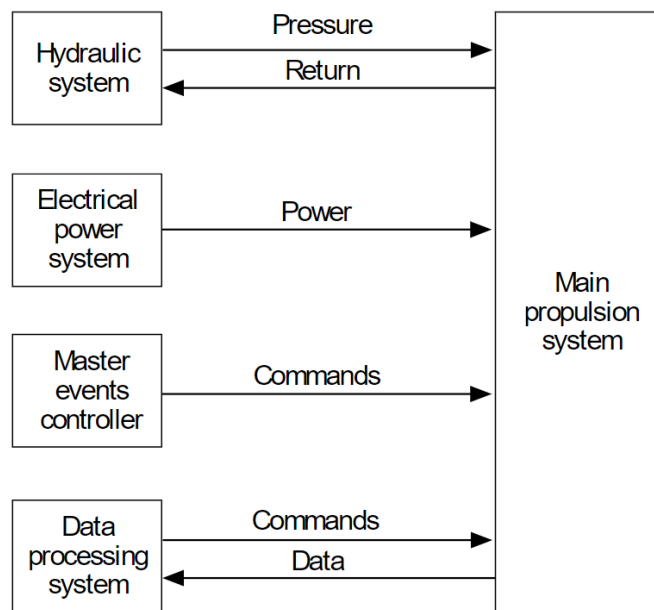

MPS CRITICAL INTERFACES

VS801

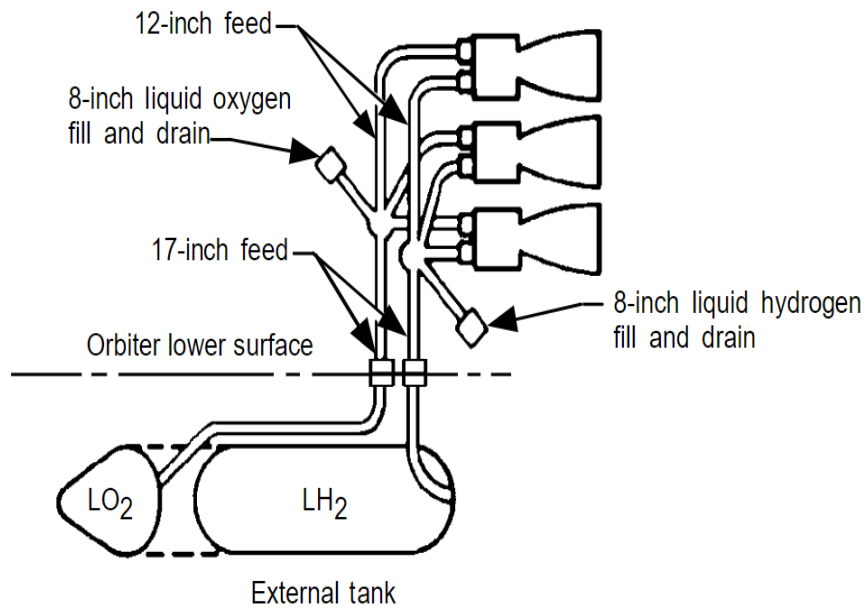

MPS FILL AND DRAIN

VS802

ORBITER MAIN ENGINE

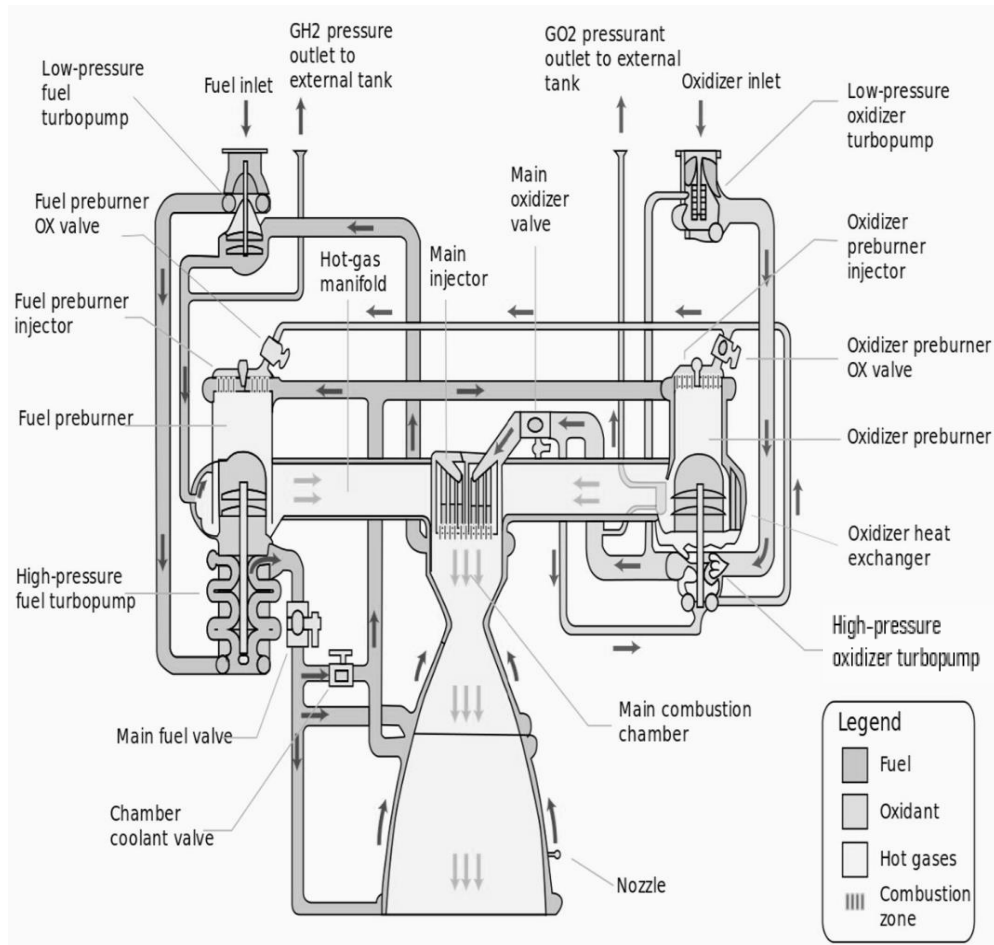

ORBITAL MANEUVERING SYSTEM (OMS)

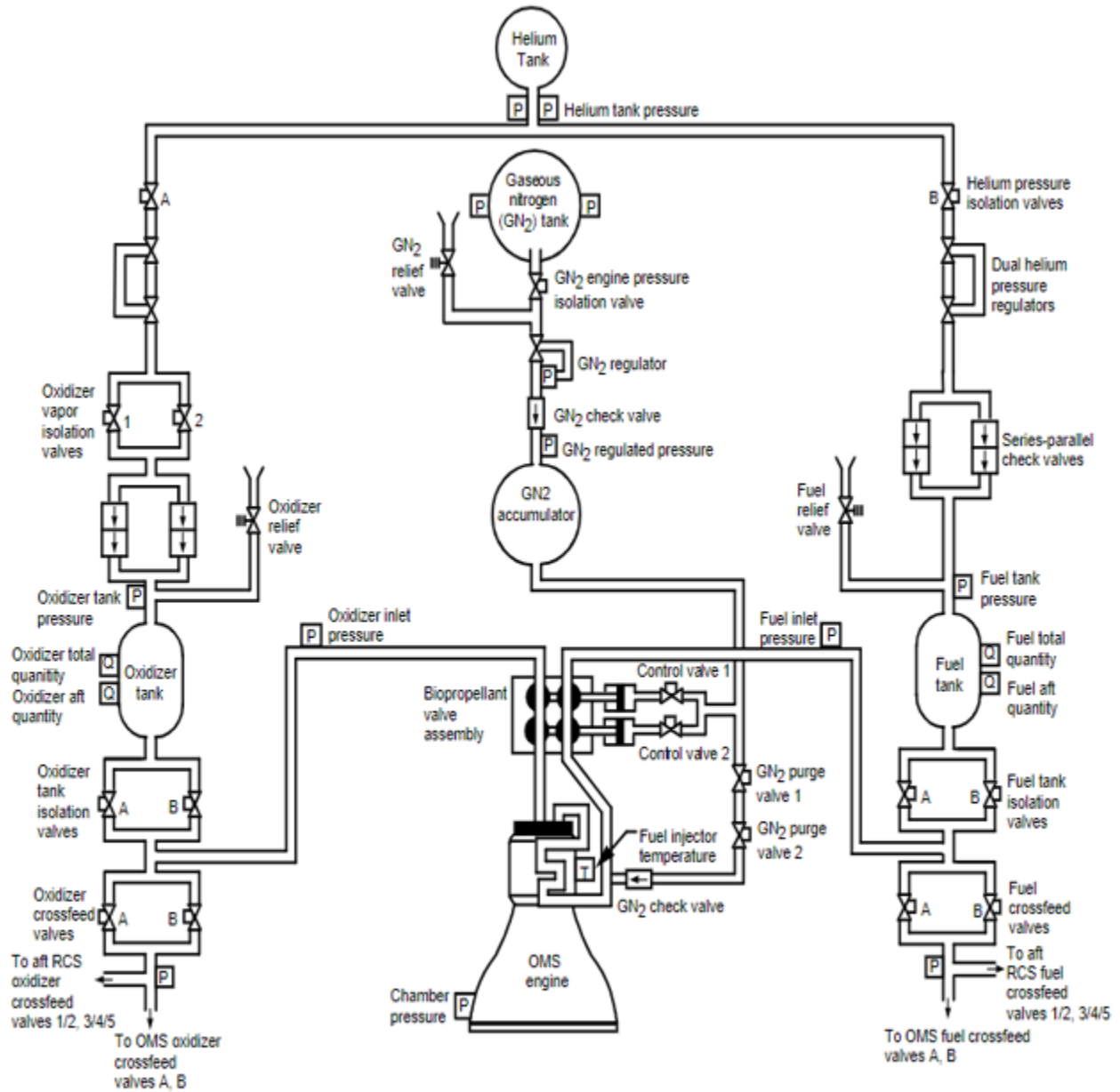

OMS PROPELLANT FEED SYSTEM

VS901

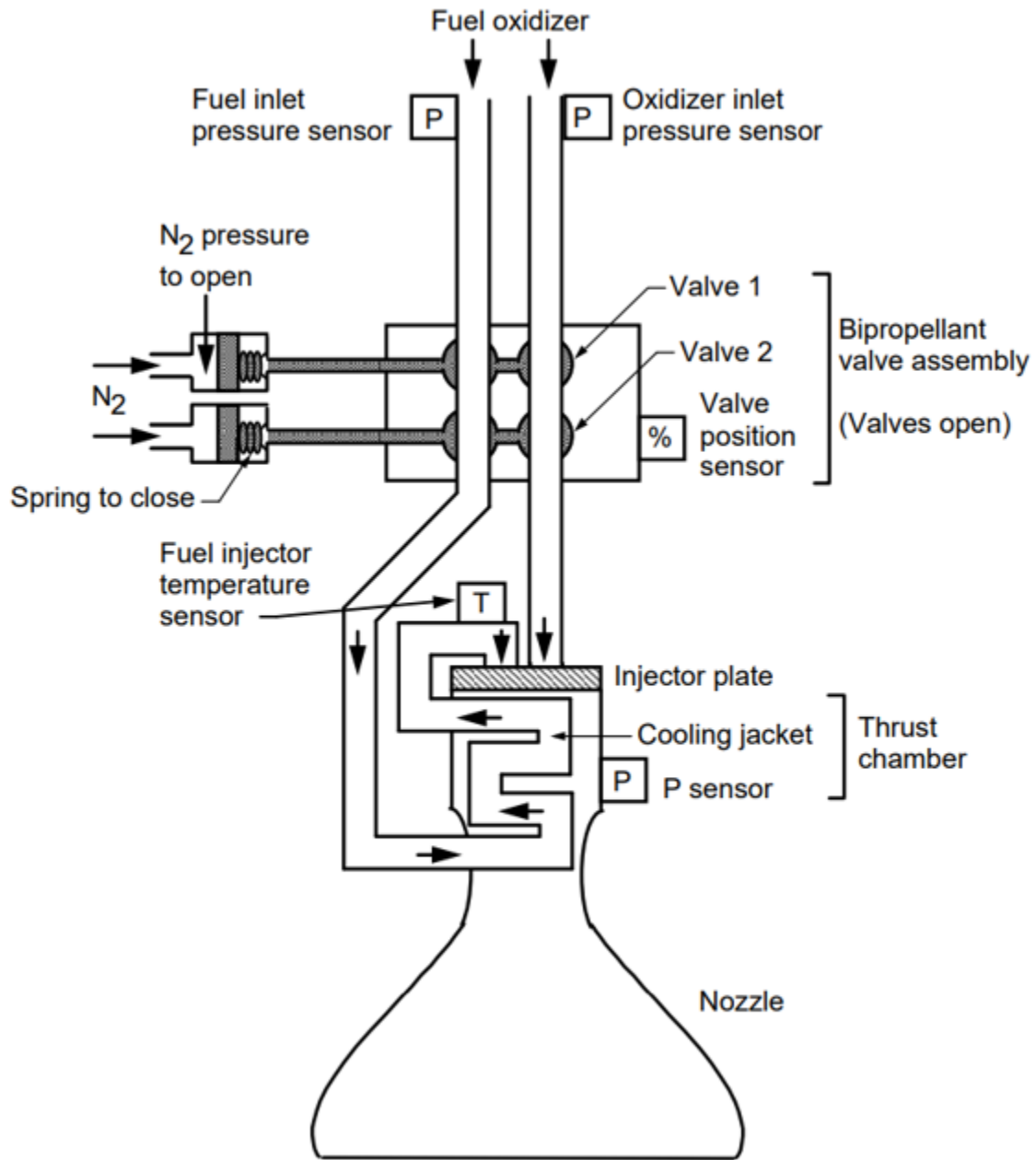

OMS ENGINE

VS902

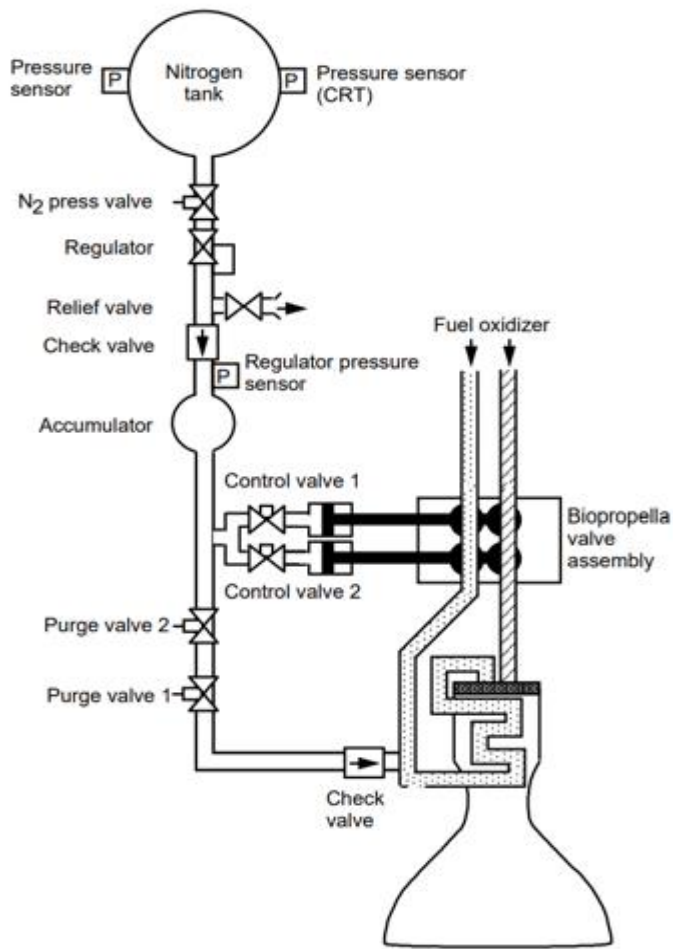

OMS NITROGEN SYSTEM

VS903

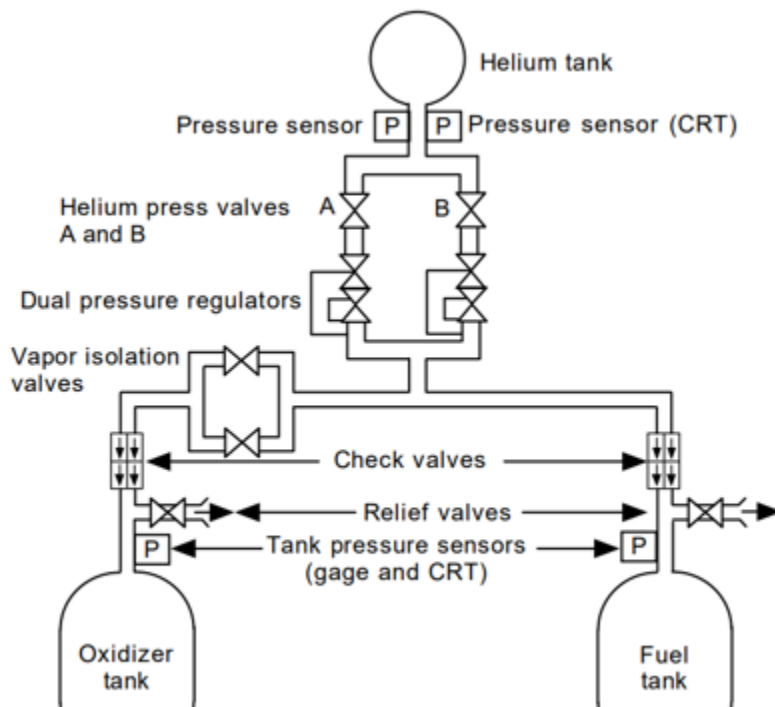

OMS HELIUM SYSTEM

VS904

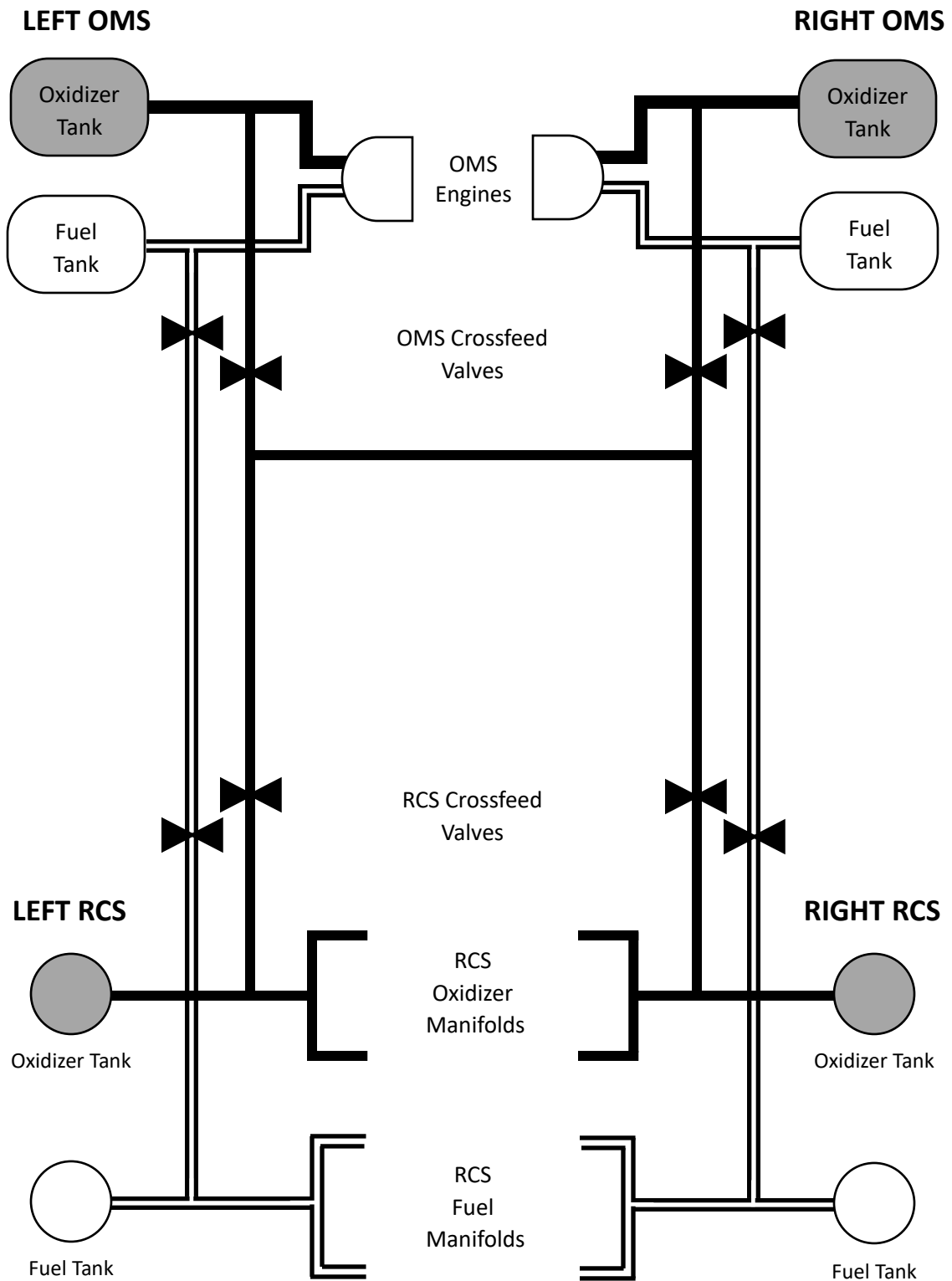

OMS and RCS Crossfeed Valves

VS905

Note: OMS and RCS Tank Isolation and Manifold Isolation Valves not shown

REACTION CONTROL SYSTEM (RCS)

FORWARD RCS SCHEMATIC

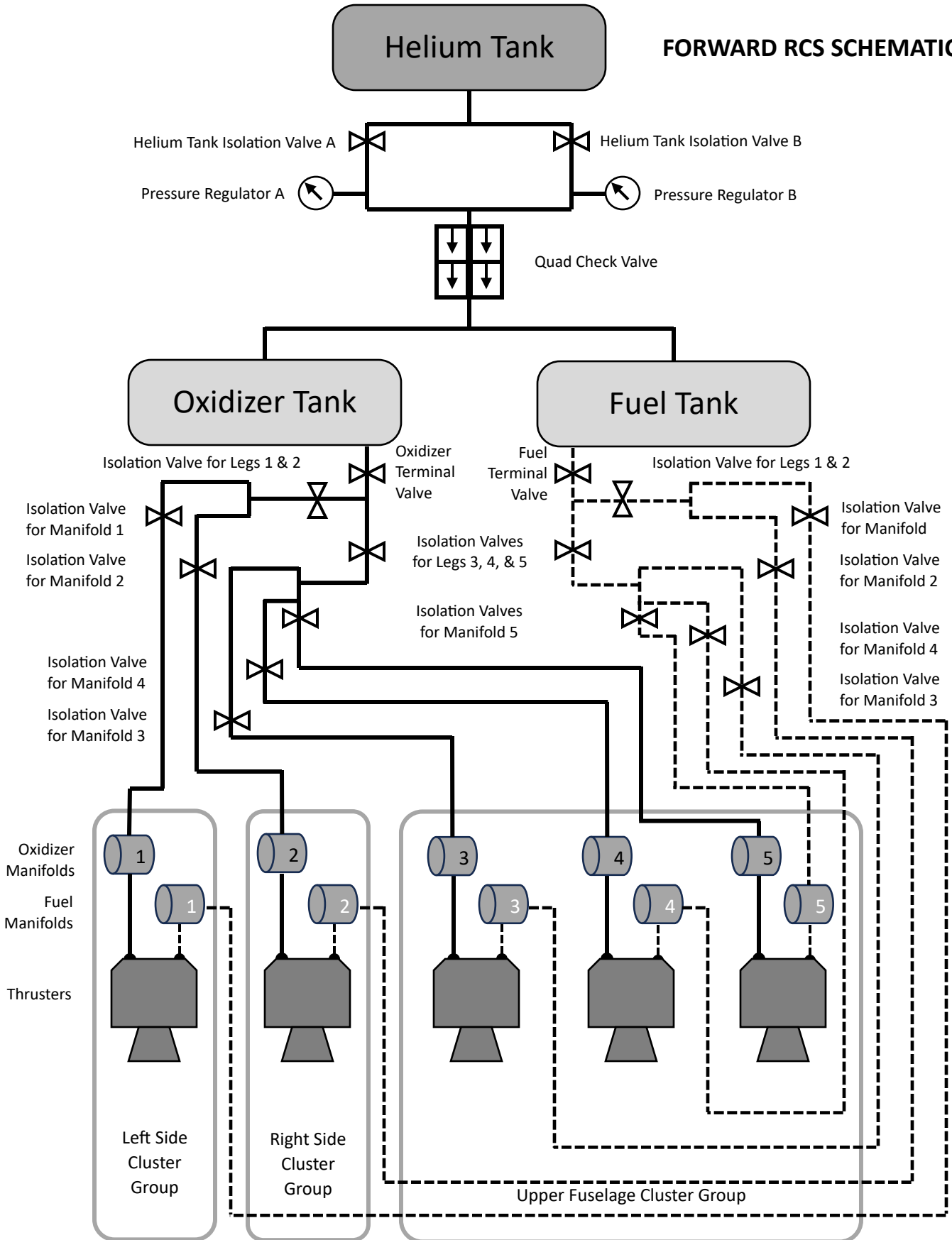

AFT RCS SCHEMATICS

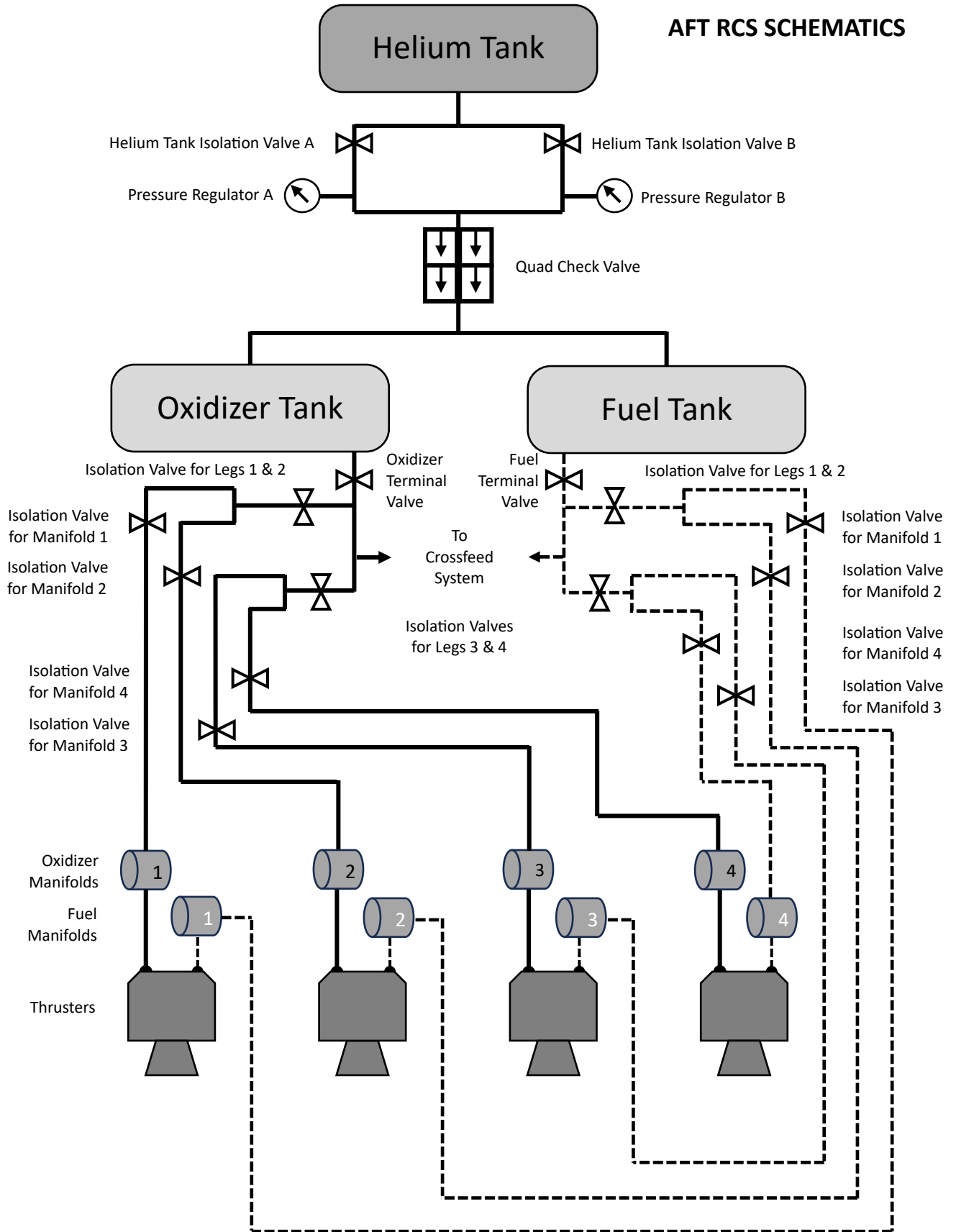

Left side RCS - AFT depicted
 Right side RCS - AFT components are identical

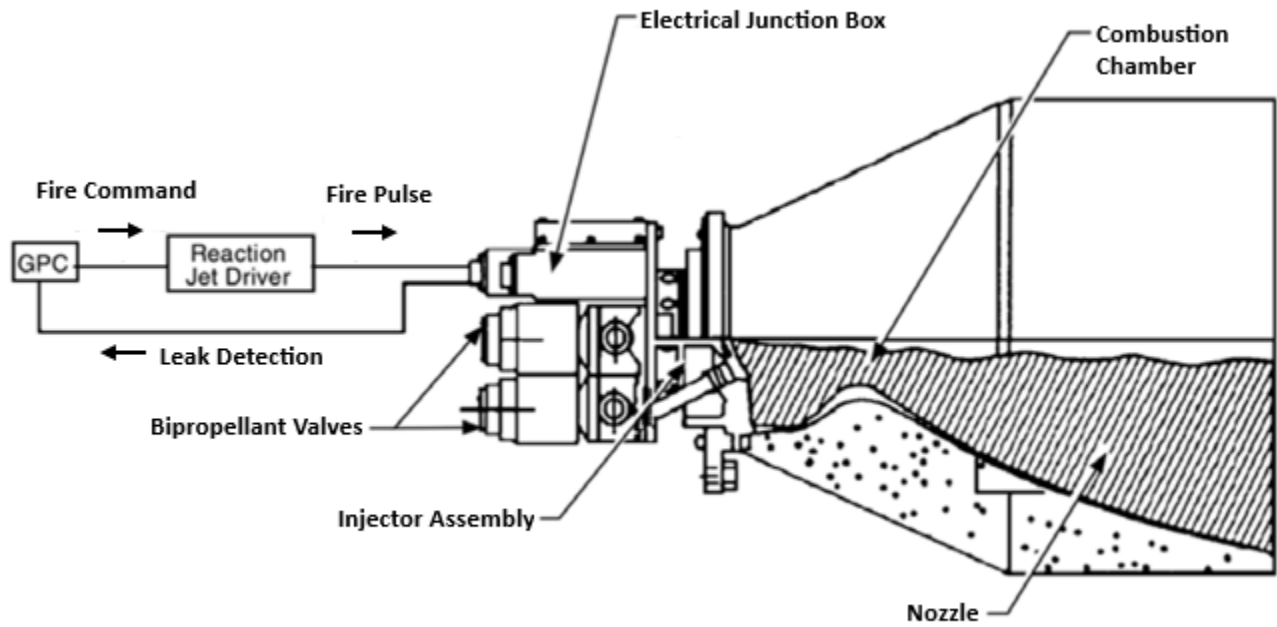

RCS PRIMARY JET

VS1003

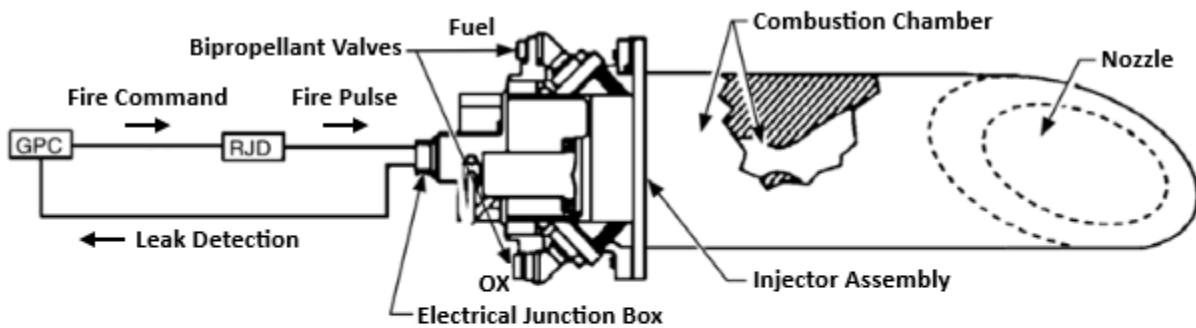

RCS VERNIER JET

VS1004

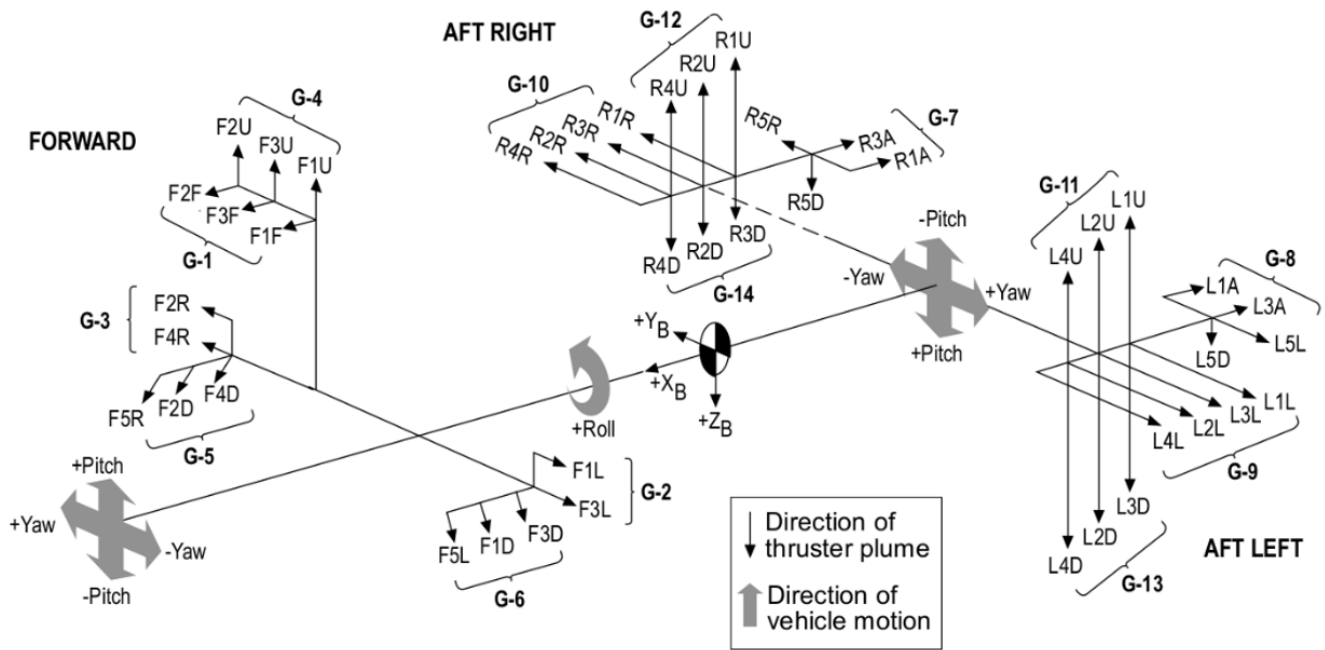

RCS JET LOCATION SCHEMATIC

VS1005

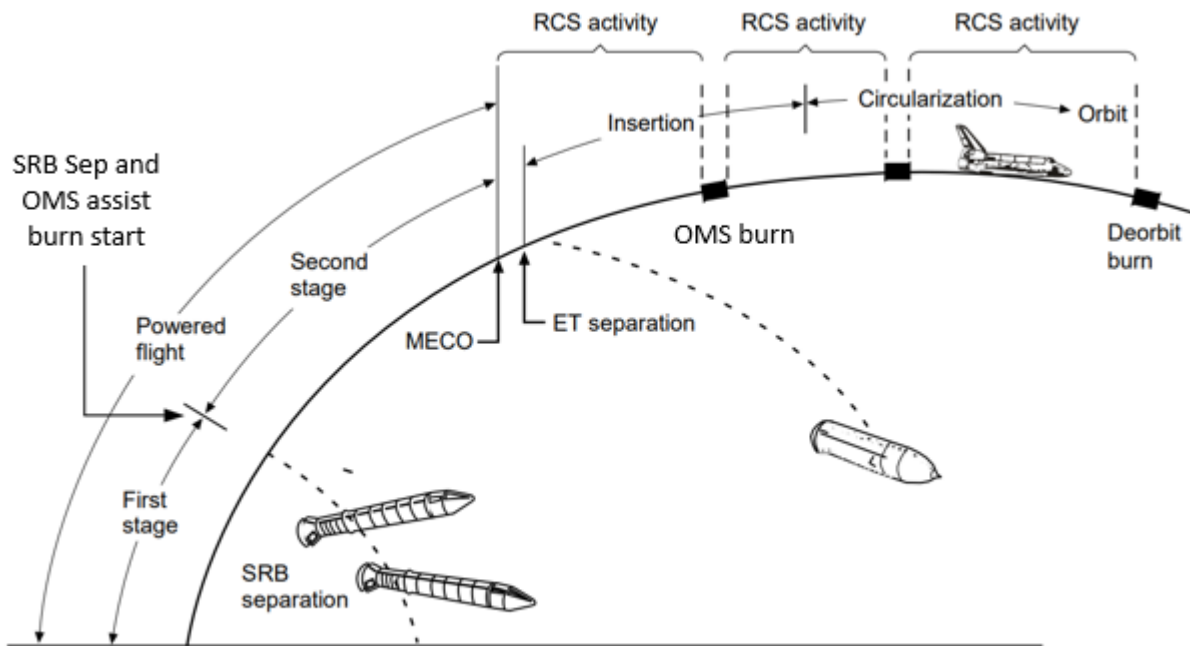

ASCENT PROFILE WITH OMS AND RCS ASCENT PROFILE

VS1006

APPENDIX A – GLOSSARY/ABBREVIATIONS

<u>A</u>	
A	Ampere. The SI base unit of electric current.
a, A	Acceleration. $a = \Delta \text{ velocity} / \Delta \text{ time}$. Acceleration = Force / Mass
AC	Alternating current
AC Bus	An electrical pathway that distributes alternating current electrical power to various Orbiter systems.
AC Bus Sensor	The AC bus sensor monitors each AC phase bus for over or under voltage, and each phase inverter for an overload signal.
AC Bus System	A three-bus system that distributes alternating current electrical power to the forward, mid, and aft sections of the orbiter for equipment used in those areas.
Acceleration	Change in velocity. Note, since velocity comprises both direction and magnitude (speed), a change in either direction or speed constitutes acceleration.
ACCUM	Accumulator
AFT	Aft is the area near, toward or in the stern or rear of an aircraft/spacecraft. Opposite of Fore or Forward
ALT	Altitude or Altimetry data.
AO	Announcement of Opportunity.
AOS	Acquisition of Signal.
Aphelion	Apoapsis in solar orbit.
Apoapsis	The farthest point in an orbit from the body being orbited.
Apogee	Apoapsis in Earth orbit.
APU	Auxiliary Power Unit. A device that provides energy for functions other than propulsion. The Space Shuttle APUs provides hydraulic pressure. The Space Shuttle has three redundant APUs, powered by hydrazine fuel. They function during powered ascent, re-entry, and landing. During ascent, the APUs provides hydraulic power for gimbaling of Shuttle's engines and control surfaces. During landing, they power the control surfaces and brakes.
Argument	Angular distance.

Argument of periapsis	The argument (angular distance) of periapsis from the ascending node.
Ascending node	The point at which an orbit crosses a reference plane (such as a planet's equatorial plane or the ecliptic plane) going north.
Asteroids	Small bodies composed of rock and metal in orbit about the sun.
AU	Astronomical Unit. AU is based on the mean Earth-to-sun distance, 149,597,870 km. Refer to "Units of Measure" section for complete information.
AV BAY	Avionics Bay. The avionics system features a five-computer central processing complex, which provides software services to all vehicle subsystems that require them.
AZ	Azimuth.
<u>B</u>	
BAT	BATTERY.
BDY	Body.
BLR	Boiler.
Boiler System	See Water Spray Boiler.
BPS	Bits per Second. This unit is the same as Baud rate.
B/U	Back Up.
BYP	Bypass.
<u>C</u>	
c	The speed of light. c is equivalent to 299,792 km per second.
Carrier	The main frequency of a radio signal generated by a transmitter prior to application of any modulation.
C-band	A range of microwave radio frequencies in the neighborhood of 4 to 8 GHz.
CDT	Central Daylight Time. Offset = UTC-5:00
Centrifugal force	The outward-tending apparent force of a body revolving around another body.
Centripetal acceleration	The inward acceleration of a body revolving around another body.

Chandler wobble	A small motion in the Earth's rotation axis relative to the surface, discovered by American astronomer Seth Carlo Chandler in 1891. Its amplitude is about 0.7 arcseconds (about 15 meters on the surface) with a period of 433 days. It combines with another wobble with a period of one year, so the total polar motion varies with a period of about 7 years. The Chandler wobble is an example of free nutation for a spinning non-spherical object.
Channel	In telemetry, one particular measurement to which changing values may be assigned.
CIRC	Circulation.
Clarke orbit	Geostationary orbit.
CNTRL	Control (or Controller).
Coma	The cloud of diffuse material surrounding the nucleus of a comet.
Comets	Small bodies composed of ice and rock in various orbits about the sun.
COMM	Communication system
Conjunction	A configuration in which two celestial bodies have their least apparent separation.
CP	Cold Plate.
CRT	Cathode Ray Tube. A video display device that allows onboard monitoring of orbiter systems, computer software processing, and manual control for flight crew data and software manipulation.
CRYO	Cryogenic.
CST	Central Standard Time. Offset = UTC-6:00
<u>D</u>	
DAP	Digital Auto Pilot. A software-based system that controls the orientation of the Space Shuttle. It can perform three-axis automatic maneuvers, attitude tracking, and rotation about any axis or body vector. Crew interface to the Digital Auto Pilot is via the Orbiter cathode ray tubes/keyboard interface, which allows the crew to control parameters in the software.
DC	Direct Current. (Electrical)
DC Bus	An electrical pathway that distributes direct current electrical power to various Orbiter systems.

DC Bus System	A three-bus system that distributes direct current electrical power to the forward, mid, and aft sections of the orbiter for equipment used in those areas.
DEC	Declination
Declination	The measure of a celestial body's apparent height above or below the celestial equator.
Density	Mass per unit volume. For example, the density of water can be stated as 1 gram/cm ³ .
Descending node	The point at which an orbit crosses a reference plane (such as a planet's equatorial plane or the ecliptic plane) going south.
Doppler Effect	The effect on frequency imposed by relative motion between transmitter and receiver. See Chapters 2, 4 and 5.
Downlink	Signal received from a spacecraft.
DPS	Data Processing System. (Maro-pad command)
DRN LN	Drain Line.
Drogue Chute	A drogue parachute, also called drag chute, is a parachute designed for deployment from a rapidly moving object.
DSN	NASA's Deep Space Network.
<u>E</u>	
Eccentricity	The distance between the foci of an ellipse divided by the major axis.
Ecliptic	The plane in which Earth orbits the sun and in which solar and lunar eclipses occur.
ECLSS	Environmental Control and Life Support System
ECS	Environmental Control System. A part of the ECLSS.
EDL	(Atmospheric) Entry, Descent, and Landing.
EDT	Eastern Daylight Time. Offset = UTC-4:00
EGT	APU Exhaust Gas Temperature
Ellipse	A closed plane curve generated in such a way that the sums of its distances from the two fixed points (the foci) is constant.
ELV	Expendable launch vehicle.
EM	Electromagnetic

EMF	Electromagnetic force (radiation).
EMR	Electromagnetic radiation.
Equator	An imaginary circle around a body which is everywhere equidistant from the poles, defining the boundary between the northern and southern hemispheres.
Equinox	The equinoxes are times at which the center of the Sun is directly above the Earth's equator. The day and night would be of equal length at that time if the Sun were a point and not a disc, and if there were no atmospheric refraction. Given the apparent disc of the Sun and the Earth's atmospheric refraction, day and night actually become equal at a point within a few days of each equinox. The vernal equinox marks the beginning of spring in the northern hemisphere, and the autumnal equinox marks the beginning of autumn in the northern hemisphere.
ERT	Earth-received time. UTC of an event at DSN receive-time, equal to SCET plus OWLT.
EST	Eastern Standard Time. Offset = UTC-5:00
ET	Ephemeris time. A measurement of time defined by orbital motions. Equates to Mean Solar Time corrected for irregularities in Earth's motions. Obsolete, replaced by TT, Terrestrial Time.
ET	External Tank
eV	Electron volt. A measure of the energy of subatomic particles.
EXEC	Execute. (Macro-pad command)
EXT	External.
<u>F</u>	
f, F	Force. Two commonly used units of force are the Newton and the dyne. Force = Mass X Acceleration.
FDLN	Feedline.
FDS	Flight Data Subsystem.
FE	Flight Engineer. A cockpit crew member.
FLT	Flight.

Fluorescence	The phenomenon of emitting light upon absorbing radiation of an invisible wavelength.
FM	Frequency modulation.
FWD	Forward. The area near, toward or in the front of an aircraft/spacecraft. Opposite of Aft.
FTS	Frequency and Timing System. A part of the Deep Space Network. Also, frequency and timing data.
<u>G</u>	
G	Universal Constant of Gravitation. Its tiny value ($G = 6.6726 \times 10^{-11} \text{ Nm}^2/\text{kg}^2$) is unchanging throughout the universe.
g	Acceleration due to a body's gravity. Constant at any given place, the value of g varies from object to object (e.g., planets), and also with the distance from the center of the object. The relationship between the two constants is $g = GM/r^2$ where r is the radius of separation between the masses' centers, and M is the mass of the primary body (e.g., a planet). At Earth's surface, the value of $g = 9.8$ meters per second per second (9.8m/s^2). See also weight.
GBX	Gearbox.
GG	Gas Generator.
Gamma rays	Electromagnetic radiation in the neighborhood of 100 femtometers wavelength.
GEO	Geosynchronous Earth Orbit.
Geostationary	A geosynchronous equatorial circular orbit. Also called Clarke orbit.
Geosynchronous	A direct, circular, low inclination orbit about the Earth having a period of 23 hours 56 minutes 4 seconds.
GMT	Greenwich Mean Time. Obsolete. UT, Universal Time is preferred.
GNC	Guidance, Navigation, and Control System.
GPC	General Purpose Computer Control. When the toggle switch is in the straight up or middle position (not on or off) it allows the valve to be controlled by the flight software loaded in the general-purpose computer.

Gravitation	The mutual attraction of all masses in the universe. Newton's Law of Universal Gravitation holds that every two bodies attract each other with a force that is directly proportional to the product of their masses, and inversely proportional to the square of the distance between them. This relation is given by the formula: $F = Gm_1m_2/d^2$, where F is the force of attraction between the two objects, given G the Universal Constant of Gravitation, masses m_1 and m_2 , and d distance. Also stated as $F_g = GMm/r^2$ where F_g is the force of gravitational attraction, M the larger of the two masses, m the smaller mass, and r the radius of separation of the centers of the masses. See also weight.
Gravitational waves	Einsteinian distortions of the space-time medium predicted by the theory of general relativity. The first direct observation of gravitational waves was made on September 14 th 2015 by LIGO and Virgo collaborations. (Not to be confused with gravity waves, see below.)
Gravity assist	Technique whereby a spacecraft takes angular momentum from a planet's solar orbit (or a satellite's orbit) to accelerate or decelerate the craft.
Gravity waves	Certain dynamical features in a planet's atmosphere (not to be confused with gravitational waves, see above).
GTO	Geostationary (or geosynchronous) Transfer Orbit.
<u>H</u>	
H₂	Chemical formula for Hydrogen Gas.
HA	Hour Angle.
Halo orbit	A spacecraft's pattern of controlled drift about an unstable Lagrange point (L1 or L2 for example) while in orbit about the primary body (e.g., the Sun).
He	Helium.
Heliocentric	Sun-centered.
Heliopause	The boundary theorized to be roughly circular or teardrop-shaped, marking the edge of the sun's influence, perhaps 100 AU from the sun.
Heliosphere	The space within the boundary of the heliopause, containing the sun and solar system.
Helium System	During prelaunch, the pneumatic helium supply provides pressure to operate the liquid oxygen and liquid hydrogen pre-valves and outboard and inboard fill and drain valves. The three engine helium supply systems are used to provide anti-icing purges.
HGA	High-Gain Antenna onboard a spacecraft.
Hohmann Transfer Orbit	Interplanetary trajectory using the least amount of propulsive energy.

Horizon	The line marking the apparent junction of Earth and sky.
Hour	A measure of time equal to 60 minutes.
Hour Angle	The angular distance of a celestial object measured westward along the celestial equator from the zenith crossing. In effect, HA represents the RA for a particular location and time of day.
HSI	Horizontal Situation Indicator. The HSI is used to assist in following both the glideslope and localizer. When tuned to the proper frequency, the navigation radio, or NAV, sends a signal to the HSI and two indicators will appear. The indicators are oriented perpendicular to each other - one oriented horizontally and the other vertically. The pilot maneuvers the aircraft so that the indicators form a "+" in the center of the HSI. When this occurs, the pilot knows that the aircraft is both on the proper glide path and is lined up with the runway.
HUD	Head-Up Display or Heads-Up Display. The HUD is any transparent display that presents data without requiring users to look away from their usual viewpoints. The origin of the name stems from a pilot being able to view information with the head positioned "up" and looking forward, instead of angled down looking at lower instruments.
HX	Heat Exchanger.
HYD	Hydraulic.
Hydraulic System	This system distributes the hydraulic pressure produced by the Auxiliary Power Unit (APU) System. The Hydraulic System is made up of three independent hydraulic systems, each of which is mated to a corresponding APU.
<u>I</u>	
ICH	Interchanger.
IF	Intermediate Frequency. In a radio system, a selected processing frequency between RF (Radio Frequency) and the end product (e.g., audio frequency).
ILS	Instrument Landing System. The ILS is a precision landing aid that is used to provide accurate azimuth and descent guidance signals for guidance to aircraft for landing on the runway under normal or adverse weather conditions.

IMU	Inertial Measurement Unit. IMUs consist of an all-attitude, four-gimbal, inertially stabilized platform. They provide inertial attitude and velocity data to the navigation software. Guidance uses the attitude data, along with state vectors from the navigation software, to develop steering commands for flight control.
Inclination	The angular distance of the orbital plane from the plane of the planet's equator, stated in degrees.
Inferior conjunction	Alignment of Earth, sun, and an inferior planet on the same side of the sun.
Inferior planet	Planet which orbits closer to the Sun than the Earth's orbit.
INBD	Inboard.
INJ	Injector.
INT	Internal.
Ion	A charged particle consisting of an atom stripped of one or more of its electrons.
IR	Infrared, meaning "below red" radiation. Electromagnetic radiation in the neighborhood of 100 micrometers wavelength.
ISOE	Integrated Sequence of Events.
ISOL	Isolation.
Isolation valves	The propellant tank isolation valves are located between the propellant tanks and the manifold isolation valves and are used to isolate the propellant tanks from the remainder of the propellant distribution system.
Isotropic	Having uniform properties in all directions.
IUS	Inertial Upper Stage.
<u>K</u>	
K-band	A range of microwave radio frequencies in the neighborhood of 12 to 40 GHz.
Keyhole	An area in the sky where an antenna cannot track a spacecraft because the required angular rates would be too high. Mechanical limitations may also contribute to keyhole size.
Klystron	A microwave traveling wave tube power amplifier used in transmitters.

Ku-band	The Ku band, used primarily for satellite communications, is the portion of the K-band radio spectrum in the 12 to 18 gigahertz (GHz) range. The symbol is short for "K-under", because it is the lower part of the original NATO K-band, which was split into three bands (Ku, K, and Ka) because of the presence of the atmospheric water vapor resonance peak at 22.24 GHz, (1.35 cm) which made the center unusable for long range transmission.
Kuiper belt	A disk-shaped region about 30 to 100 AU from the sun considered to be the source of the short-period comets.
<u>L</u>	
Lagrange points	Five points with respect to an orbit which a body can stably occupy. Designated L1 through L5.
LAN	Local area network for inter-computer communications.
Laser	Light Amplification by Stimulated Emission of Radiation. Compare with Maser.
Latitude	Circles in parallel planes to that of the equator defining north-south measurements, also called parallels.
L-band	A range of microwave radio frequencies in the neighborhood of 1 to 2 GHz.
LCP	Left-hand circular polarization.
LEO	Low Equatorial Orbit.
LGA	Low-Gain Antenna onboard a spacecraft.
Light	Electromagnetic radiation in the neighborhood of 1-nanometer wavelength.
Light time	The amount of time it takes light or radio signals to travel a certain distance at light speed.
Lightspeed	299,792 km per second, the constant c.
Lightyear	A measure of distance, the distance light travels in one year, about 63,197 AU.
LN	Line.
Local time	Time adjusted for location around the Earth or other planets in time zones.
Longitude	Great circles that pass through both the north and south poles, also called meridians.
LOS	Loss of Signal, used in DSN operations.
LOX	Liquid Oxygen.

<u>M</u>	
m, M	Mass. The kilogram is the standard unit of mass. Mass = Acceleration / Force.
Main Propulsion System	Within the orbiter aft fuselage, liquid hydrogen and liquid oxygen pass through the manifolds, distribution lines and valves of the propellant management subsystem. During prelaunch activities, this subsystem is used to control the loading of liquid oxygen and liquid hydrogen in the external tank. During SSME thrusting periods, propellants from the external tank flow into this subsystem and to the three SSMEs. The subsystem also provides a path that allows gases tapped from the three SSMEs to flow back to the external tank through two gas umbilicals to maintain pressure in the external tank's liquid oxygen and liquid hydrogen tanks. After MECO, this subsystem controls MPS dumps, vacuum inerting and MPS re-pressurization for entry.
Major Axis	The maximum diameter of an ellipse.
MANF	Manifold.
Maser	A microwave traveling wave tube amplifier named for its process of Microwave Amplification by Stimulated Emission of Radiation. Compare with Laser. In the Deep Space Network, masers are used as low-noise amplifiers of downlink signals, and also as frequency standards.
Mass	A fundamental property of an object comprising a numerical measure of its inertia; the amount of matter in the object. While an object's mass is constant (ignoring Relativity for this purpose), its weight will vary depending on its location. Mass can only be measured in conjunction with force and acceleration.
MDT	Mountain Daylight Time. Offset = UTC-6:00
Mean solar time	Time based on an average of the variations caused by Earth's non-circular orbit. The 24-hour day is based on mean solar time.
MEC	Master Events Controller. Two master events controllers (MEC's) are installed within the Orbiter to provide the control interface for critical liftoff and stage-separation functions.
MECO	Main Engine Cut Off. The point where the main engines shut down. This occurs on the orbiter at approximately 8 minutes and 55 seconds into the flight.
Meridians	Great circles that pass through both the north and south poles, also called lines of longitude.

Meteor	A meteoroid which is in the process of entering Earth's atmosphere. It is called a meteorite after landing.
Meteorite	Rocky or metallic material which has fallen to Earth or to another planet.
Meteoroid	Small bodies in orbit about the sun which are candidates for falling to Earth or to another planet.
MFD	Multi-Function Display. The MFD is a small screen in an aircraft/spacecraft that can be used to display information to the pilot in numerous configurable ways.
MGA	Medium-Gain Antenna onboard a spacecraft. MLI
μm	Micrometer (10^{-6} m).
MLI	Multi-layer insulation (spacecraft blanketing).
MMU	Mass Memory Unit. The principal function of the MMU, besides storing the basic flight software, is to store background formats and code for certain displays and the checkpoints that are written periodically to save selected data in case the systems management GPC fails.
Modulation	The process of modifying a radio frequency by shifting its phase, frequency, or amplitude to carry information.
MST	Mountain Standard Time. Offset = UTC-7:00
MSTR	Master.
Multiplexing	A scheme for delivering many different measurements in one data stream.
<u>N</u>	
N	Newton, the SI unit of force. One Newton is equal to the force required to accelerate a 1-kg mass, 1 m per second per second (1m/s^2).
N₂	Chemical formula for Nitrogen gas.
Nadir	The direction from a spacecraft directly down toward the center of a planet. Opposite of Zenith.
NE	Near Encounter phase in flyby mission operations.
NiCad	Nickel-cadmium rechargeable battery.
Nm	Nautical Miles.
Nodes	Points where an orbit crosses a reference plane.

Non-coherent	Communications mode wherein a spacecraft generates its downlink frequency independent of any uplink frequency.
Nucleus	The central body of a comet.
Nutation	A small nodding motion in a rotating body. Earth's nutation has a period of 18.6 years and an amplitude of 9.2 arc seconds.
<u>O</u>	
O₂	Chemical formula for Oxygen Gas.
OB	Observatory phase in flyby mission operations encounter period.
OMS	Orbital Maneuvering System. The OMS is a system of rocket engines for use on the space shuttle orbiter for orbital injection and modification.
One-way Comm	Communications mode consisting only of downlink received from a spacecraft.
Oort cloud	A large number of comets theorized to orbit the sun in the neighborhood of 50,000 AU.
Opposition	Configuration in which one celestial body is opposite another in the sky. A planet is in opposition when it is 180 degrees away from the sun as viewed from another planet (such as Earth). For example, Saturn is at opposition when it is directly overhead at midnight on Earth.
OTM	Orbit Trim Maneuver. A spacecraft propulsive maneuver.
OUTBD	Outboard.
OWLT	One-Way Light Time. The elapsed time between Earth and a spacecraft or solar system body.
<u>P</u>	
P	Pressure. See also Press
PAM	Payload Assist Module upper stage.
Parallels	Circles in parallel planes to that of the equator defining north-south measurements, also called lines of latitude.
PDT	Pacific Daylight Time. Offset = UTC-7:00
PE	Post Encounter phase in flyby mission operations.
Periapsis	The point in an orbit closest to the body being orbited.

Perigee	Periapsis for Earth orbit.
Phase	1 - The angular distance between peaks or troughs of two waveforms of similar frequency 2 - The particular appearance of a body's state of illumination, such as the full or crescent phases of the Moon; 3 - Any one of several predefined periods in a mission or other activity.
Photovoltaic	Materials that convert light into electric current.
PL	Payload. (Also see PYLD)
Plasma	Electrically conductive fourth state of matter (other than solid, liquid, or gas), consisting of ions and electrons.
PM	Post meridiem (Latin: after midday), afternoon.
PRESS	Pressure.
Prograde	1 - Orbital motion in the usual direction of celestial bodies within a given system, i.e. in the direction of the planet's rotation. 2 - Orbit in which the spacecraft moves in the same direction as the planet rotates.
PRSDS	Power Reactant Storage and Distribution System
PST	Pacific Standard Time. Offset = UTC-8:00
PWR	Power.
PYLD	Payload.
<u>Q</u>	
QTY	Quantity
Quasar	Quasi-stellar object observed mainly in radio waves. Quasars are extragalactic objects believed to be the very distant centers of active galaxies.
<u>R</u>	
RA	Right Ascension.
RAD	Radiator.
Radian	Unit of angular measurement equal to the angle at the center of a circle subtended by an arc equal in length to the radius. Equals about 57.296 degrees.
RAM	Random Access Memory.

RCS	Reaction Control System. The RCS is a subsystem of a spacecraft whose purpose is attitude control and steering by the use of thrusters. An RCS system is capable of providing small amounts of thrust in any desired direction or combination of directions. The RCS engines use a hypergolic propellant which lights up when its two components (Fuel and Oxidizer) come into contact. This allows the system to be almost fail-safe due to the simple nature of the propellant.
REAC	Reactant.
RECIRC	Recirculation.
Reflection	The deflection or bouncing of electromagnetic waves when they encounter a surface.
Refraction	The deflection or bending of electromagnetic waves when they pass from one kind of transparent medium into another.
REG	Regulator.
Retrograde	1 - Motion in an orbit opposite to the usual orbital direction of celestial bodies within a given system, i.e. in the opposite direction of the planet's rotation. 2 - Orbit in which the spacecraft moves in the opposite direction from the planet's rotation.
RF	Radio Frequency.
RFI	Radio Frequency Interference.
RGA	Rate Gyro Assembly. The orbiter Rate Gyro Assemblies are used by the flight control system during ascent, entry and aborts as feedback to final rate errors that are used to augment stability and for display on the commander's and pilot's attitude director indicator.
Right Ascension	The angular distance of a celestial object measured in hours, minutes, and seconds along the celestial equator eastward from the vernal equinox.
Rise	As in ascending above the horizon.
ROM	Read-only Memory.
RSVR	Reservoir.
<u>S</u>	
s	Second. The SI base unit of time.

SA	Solar Array. Photovoltaic panels onboard a spacecraft.
SAR	Synthetic Aperture Radar
Satellite	A small body which orbits a larger one. A natural or an artificial moon. Earth-orbiting spacecraft are called satellites. While deep-space vehicles are technically satellites of the sun or of another planet, or of the galactic center, they are generally called spacecraft instead of satellites.
S-band	A range of microwave radio frequencies of about 2 to 4 GHz.
SCET	Spacecraft Event Time. Equal to ERT minus OWLT.
SCLK	Spacecraft Clock Time. A counter onboard a spacecraft.
Sec	Second.
Second	The SI base unit of time.
Semi-major axis	Half the distance of an ellipse's maximum diameter, the distance from the center of the ellipse to one end.
Set	As in going below the horizon.
SI	The International System of Units (metric system).
SI base unit	One of seven SI units of measure from which all the other SI units are derived.
SI derived unit	One of many SI units of measure expressed as relationships of the SI base units. For example, the watt, W, is the SI derived unit of power. It is equal to joules per second. $W = J/s = m^2 * kg * s^{-3}$ (Note: the joule, J, is the SI derived unit for energy, work, or quantity of heat.)
Sidereal time	Time relative to the stars other than the sun.
SNR	Signal-to-Noise Ratio.
SOE	Sequence of Events.
Solar wind	Flow of lightweight ions and electrons (which together comprise plasma) thrown from the sun.
Specific Impulse	A measurement of a rocket's relative performance. Expressed in seconds, the number of which a rocket can produce one pound of thrust from one pound of fuel. The higher the specific impulse, the less fuel required to produce a given amount of thrust.
Spectrum	A range of frequencies or wavelengths.

SRB	Solid Rocket Booster.
SSME	Space Shuttle Main Engines. The SSMEs are reusable liquid-fuel rocket engines, each Orbiter ascent to orbit is propelled by three engines
Star Tracker	The star tracker system is part of the orbiter's navigation system which works to help maintain the IMU during flight.
STS	Space Transportation System. STS is commonly known as the Space Shuttle. It is comprised of the Orbiter, External Tank (ET) and Solid-Rocket Boosters (SRB).
Subcarrier	Modulation applied to a carrier which is itself modulated with information-carrying variations.
SYS	System.
<u>T</u>	
TCM	Trajectory Correction Maneuver. A spacecraft propulsive maneuver.
TCS	Thermal Conditioning System. The TCS consists of an air revitalization system, water coolant loop systems, atmosphere revitalization pressure control system, active thermal control system, supply water and wastewater system, waste collection system and airlock support system. These systems interact to provide a habitable environment for the flight crew in the crew compartment in addition to cooling or heating various orbiter systems or components.
TK	Tank (Listed on Data Panels)
TNK	Tank (Listed on Switch Panels)
TOS	Transfer Orbit Stage, upper stage.
Transducer	Device for changing one kind of energy into another, typically from heat, microphone, or speaker.
Transponder	An electronic device which combines a transmitter and a receiver.
TRM	Transmission Time. UTC Earth time of uplink.
True anomaly	The angular distance of a point in an orbit past the point of periapsis, measured in degrees.
<u>U</u>	

UHF	Ultra-high frequency (around 300MHz).
Uplink	Signal sent to a spacecraft.
UT	Universal Time. UT is also called Zulu (Z) time, previously Greenwich Mean Time. UT is based on the imaginary "mean sun," which averages out the effects on the length of the solar day caused by Earth's slightly non-circular orbit about the sun. UT is not updated with leap seconds as is UTC.
UTC	Universal Time (Coordinated). The world-wide scientific standard of timekeeping. It is based upon carefully maintained atomic clocks and is highly stable. Its rate does not change by more than about 100 picoseconds per day. The addition or subtraction of leap seconds, as necessary, at two opportunities every year adjusts UTC for irregularities in Earth's rotation.
UV	Ultraviolet (meaning "above violet") radiation. Electromagnetic radiation of about 100 nanometers wavelength.
<u>V</u>	
Velocity	A vector quantity whose magnitude is a body's speed and whose direction is the body's direction of motion.
VLV	Valve.
VOR	Very High Frequency Omni-Directional Range. VOR is a ground-based electronic system that provides azimuth information for high and low altitude routes and airport approaches.
<u>W</u>	
W	Watt. The watt a measure of electrical power equal to potential in volts times current in amps. (The Watt can also be expressed as $W = J/s$. See SI derived units)
Walking orbit	A spacecraft orbit that precesses, wherein the location of periapsis changes with respect to the planet's surface in a useful way.
WSB	Water Spray Boiler.
Water Spray Boiler	The water spray boiler (WSB) system consists of three identical independent water spray boilers, one for each APU/hydraulic system. The boilers are located in the aft fuselage of the orbiter. Each WSB cools the corresponding APU lube oil system and hydraulic system by spraying water onto their lines; as the water boils off, the lube oil and hydraulic fluid are cooled.

Wavelength	The distance that a wave from a single oscillation of electromagnetic radiation will propagate during the time required for one oscillation. Also, the distance between two corresponding points on a wave. For example, the distance between two crests.
Weight	The gravitational force exerted on an object by a higher mass body. The weight of an object with mass m is $w=mg$. Units: Newtons. The gravitational field strength, g , is the local acceleration due to a body's gravity.
WWW	World-Wide Web.
<u>X</u>	
X-band	A range of microwave radio frequencies of about 8 to 12 GHz.
X-ray	Electromagnetic radiation of about 100 picometer wavelength.
<u>Z</u>	
Z	Zulu in the phonetic alphabet, stands for UT, Universal Time.
Zenith	The point on the celestial sphere directly above the observer. Opposite the Nadir.

APPENDIX B - SPACE FLIGHT AND VEHICLE HISTORY

History of Human Spaceflight

Spaceflight began in the 20th century following theoretical and practical breakthroughs by Konstantin Tsiolkovsky, Robert H. Goddard, and Hermann Oberth.

$$\Delta v = v_e \ln \left(\frac{m_o}{m_f} \right)$$

CLASSICAL ROCKET EQUATION

The first successful large-scale rocket programs were initiated in 1920s Germany by Fritz von Opel and Max Valier, and eventually in Nazi Germany by Wernher von Braun. The first rocket to reach space was a German V-2 rocket, on a vertical test flight in June 1944.

In 1947, the US sent the first animals into space, fruit flies, although not into orbit, through a V-2 rocket launched from White Sands Missile Range, New Mexico. On June 14, 1949, the US launched the first mammal into space, a rhesus macaque monkey named Albert II, on a sub-orbital flight.

The Soviet Union took the lead in the post-war Space Race, launching the first satellite, the first man and the first woman into orbit.

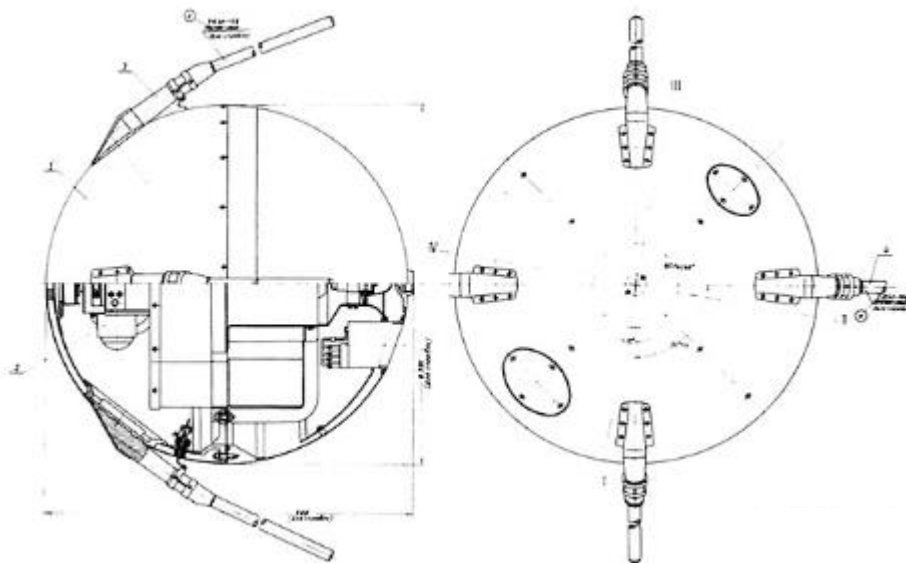

SPUTNIK DESIGN DIAGRAM

The space race began in earnest in 1957 when both the US and the USSR made statements announcing they planned to launch artificial satellites during the 18-month long International Geophysical Year of July 1957 to December 1958. On July 29, 1957, the US announced a planned launch of the Vanguard by the spring of 1958, and on July 31, the USSR announced it would launch a satellite in the fall of 1957.

On October 4, 1957, the Soviet Union launched Sputnik 1, the Earth's first artificial satellite.

On November 3, 1957, the Soviet Union launched a second satellite, Sputnik 2, and the first to carry a living animal into orbit, a dog named Laika. Sputnik 3 was launched on May 15, 1958, and carried a large array of instruments for geophysical research and provided data on pressure and composition of the upper atmosphere, concentration of charged particles, photons in cosmic rays, heavy nuclei in cosmic rays, magnetic and electrostatic fields, and meteoric particles.

After a series of failures with the program, the US succeeded with Explorer 1, which became the first US satellite in space, on February 1, 1958. This carried scientific instrumentation and detected the theorized Van Allen radiation belt.

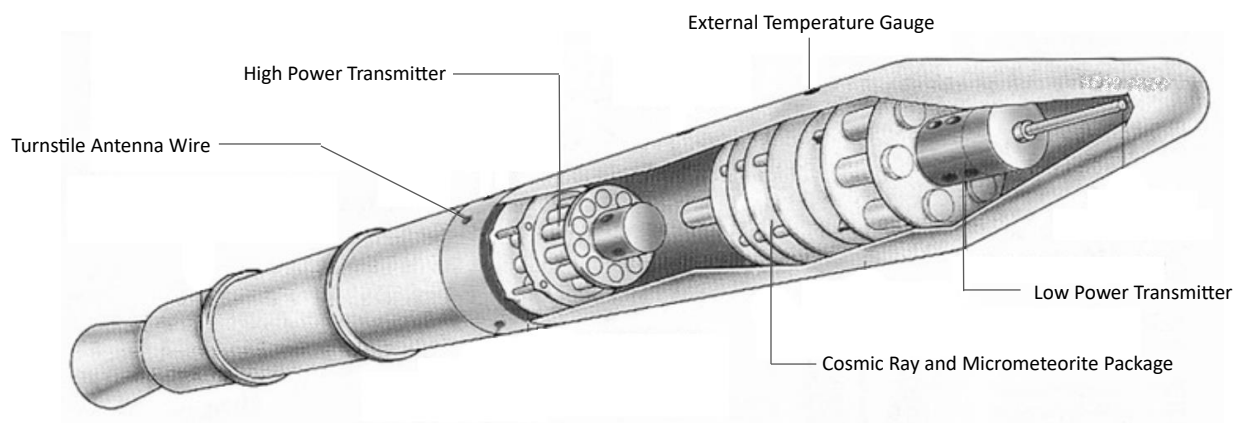

The US public shock over Sputnik 1 became known as the Sputnik crisis. On July 29, 1958, the US Congress passed legislation turning the National Advisory Committee for Aeronautics (NACA) into the National Aeronautics and Space Administration (NASA) with responsibility for the nation's civilian space programs.

In 1959, NASA began Project Mercury to eventually launch single-man capsules into Earth orbit and chose a corps of seven astronauts introduced as the Mercury Seven.

On January 31, 1961, through NASA's Mercury-Redstone 2 mission, a chimpanzee named Ham became the first Hominidae in space.

On April 12, 1961, the USSR opened the era of crewed spaceflight, with the flight of the first cosmonaut, Yuri Gagarin. Gagarin's flight, part of the Soviet Vostok space exploration program, took 108 minutes and consisted of a single orbit of the Earth.

On May 5, 1961, the US launched its first suborbital Mercury astronaut, Alan Shepard, in the Freedom 7 capsule. Unlike Gagarin, Shepard manually controlled his spacecraft's attitude and landed inside it thus technically making Freedom 7 the first complete human spaceflight by then FAI definitions, but later it recognized that Gagarin was the first human to fly into space.

On August 7, 1961, Gherman Titov, another Soviet cosmonaut, became the second man in orbit during his Vostok 2 mission.

By June 16, 1963, the Union had launched a total of six Vostok cosmonauts, two pairs of them flying concurrently, and accumulating a total of 260 cosmonaut-orbits and just over sixteen cosmonaut-days in space.

The first woman in space was former civilian parachutist Valentina Tereshkova, who entered orbit on June 16, 1963, aboard the Soviet mission Vostok 6. The chief Soviet spacecraft designer, Sergey Korolyov, conceived of the idea to recruit a female cosmonaut corps and launch two women concurrently on Vostok 5/6. However, his plan was changed to launch a male first in Vostok 5, followed shortly afterward by Tereshkova.

US SPACE PROJECTS

PROJECT MERCURY

Project Mercury was the first human spaceflight program of the United States, running from 1958 through 1963. Project Mercury made 25 flights, six of which carried astronauts between 1961 and 1963. The objectives of the program were:

- To orbit a human spacecraft around Earth
- To investigate a person's ability to function in space
- To recover both the astronaut and spacecraft safely.

More than 2 million people from government agencies and the aerospace industry combined their skills, initiative, and experience to make the project possible.

Mercury showed that humans could function for periods up to 34 hours of weightless flight. John Glenn became the first American to orbit the Earth on February 20, 1962, aboard the Mercury-Atlas 6.

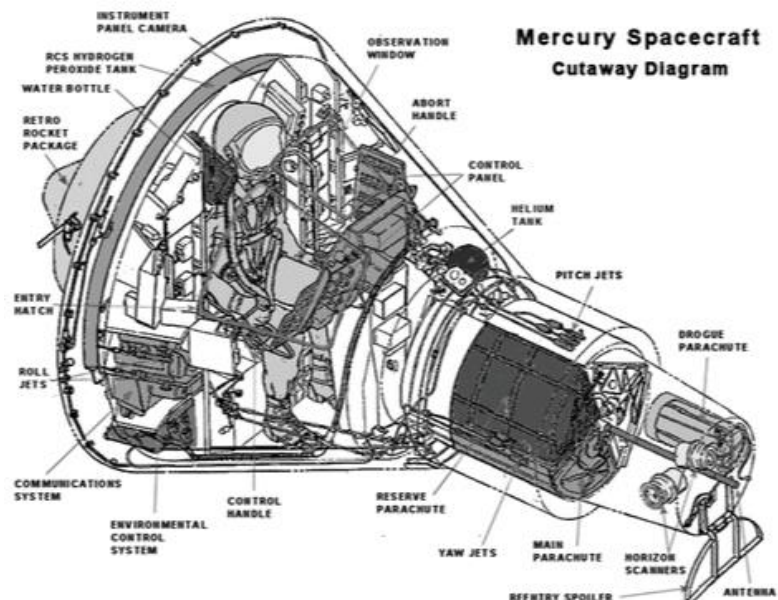

PROJECT GEMINI

Project Gemini was NASA's second human spaceflight program. The Gemini program primarily tested equipment and mission procedures and trained astronauts and ground crews for future Apollo missions to the Moon.

The program's main goals were:

- To test an astronaut's ability to fly long duration flights (14 days)
- To understand how a spacecraft could rendezvous and dock with another vehicle in Earth orbit
- To perfect re-entry landing methods
- to further understand the effects of longer spaceflights on astronauts

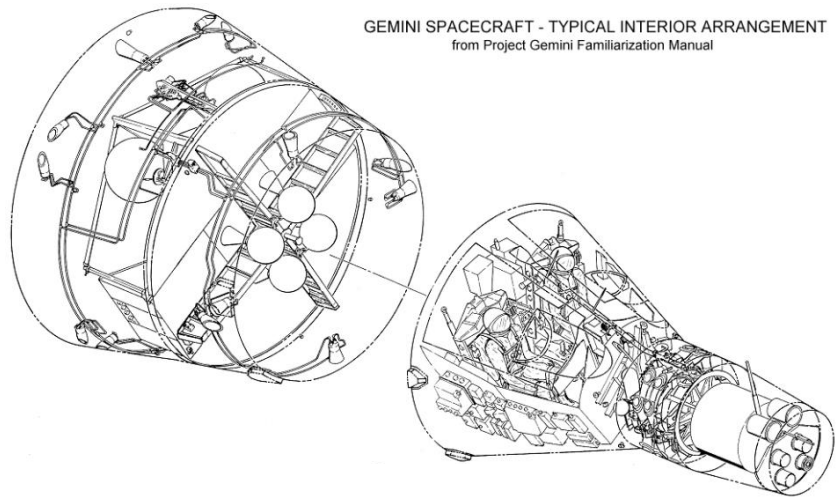

NASA selected "Gemini" because the word is Latin for "twins," and the Gemini was a capsule built for two. The program ran from 1961 to 1966. During the Gemini 4 mission, Ed White became the first American to make an extravehicular activity (EVA, or "spacewalk"), on June 3, 1965. Gemini 6A and 7 accomplished the first space rendezvous on December 15, 1965. Gemini 8 achieved the first space docking with an uncrewed Agena Target Vehicle on March 16, 1966. Gemini 8 was also the first US spacecraft to experience in-space critical failure endangering the lives of the crew.

APOLLO PROGRAM

The Apollo program was the third human spaceflight program carried out by NASA. The program's goal was to orbit and land crewed vehicles on the Moon. The program ran from 1969 to 1972. The Apollo program was hit by tragedy as the first crew prepared to fly. On Jan. 27, 1967, fire swept through the Apollo 1 command module during a preflight test on the Cape Kennedy launch pad. Astronauts Gus Grissom, Ed White, and Roger Chaffee lost their lives. NASA was not deterred, but rather changed how things were done to ensure the safety and success of future missions. Apollo 8 was the first human spaceflight to leave Earth orbit and orbit the Moon on December 21, 1968.

Exactly eight years, one month and 26 days after President Kennedy challenged Americans to reach for the Moon, Project Apollo landed the first humans there. Neil Armstrong and Buzz Aldrin became the first men to set foot on the Moon during the Apollo 11 mission on July 20, 1969. A total of 12 humans walked on the moon during the six Apollo

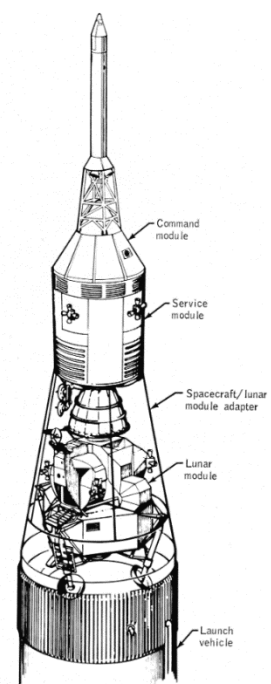

APOLLO LAUNCH CONFIGURATION FOR LUNAR LANDING MISSION

missions that landed on the moon. The last two humans on the moon were Gene Cernan and Harrison Schmitt, during the Apollo 17 mission in December of 1972. The Apollo program also developed technology to meet other national interests in space, conducted scientific exploration of the Moon, and developed humanity's capability to work in the lunar environment.

In the 1970s, U.S.-Soviet political tensions that had accelerated the space race began to thaw. Competition gave way to cooperation between the two nations with the Apollo-Soyuz Test Project.

SKYLAB

The Skylab program's goal was to create the first U.S. space station. The program marked the last launch of the Saturn V rocket on May 14, 1973. Many experiments were performed on board, including unprecedented solar studies. The longest crewed mission of the program was Skylab 4 which lasted 84 days, from November 16, 1973 to February 8, 1974. The total mission duration was 2249 days, with Skylab finally falling from orbit over Australia on July 11, 1979.

SPACE SHUTTLE PROGRAM

Although its pace slowed, space exploration continued after the end of the Space Race. The United States created the Space Transport System (STS), better known as the Space Shuttle Program, to allow reusable spacecraft to complete routine Earth to Orbit missions. The first Space Shuttle created was named Enterprise (The SAC simulator is named after this vehicle). It was used for approach and landing testing but never flew in space. The U.S. launched the first reusable spacecraft, Columbia, on the 20th anniversary of Gagarin's flight, April 12, 1981. On November 15, 1988, the Soviet Union duplicated this with an uncrewed flight of the only Buran-class shuttle to fly, its first and only reusable spacecraft. It was never used again after the first flight; instead, the Soviet Union continued to develop space stations using the Soyuz craft as the crew shuttle.

Over 30 years, NASA's space shuttle fleet—Columbia, Challenger, Discovery, Atlantis and Endeavour—flew 135 missions and carried 355 different people to space. The space shuttle carried people into orbit repeatedly; launched, recovered, and repaired satellites; conducted cutting-edge research; and built the largest structure in space, the International Space Station. The space shuttle pushed the bounds of discovery ever farther, requiring not only advanced technologies but also the tremendous efforts of thousands of civil servants and contractors throughout NASA's field centers and across the nation. Tragically, NASA lost two crews of seven in the 1986 Challenger accident and the 2003 Columbia accident. Sally Ride became the first American woman in space in 1983. Eileen Collins was the first female Shuttle pilot, and with Shuttle mission STS-93 in July 1999 she became the first woman to command a US spacecraft. The first African American, Hispanic, and Asian-American astronauts also flew during the 135 flights of the space shuttle program.

International collaboration among many nations would become the norm during the space shuttle era and current cooperation in human spaceflight with the International Space Station. These partnerships have taught us more about the universe, improved our lives at home, and expanded the possibilities for future exploration into deep space.