

COLLETS

MCI8579

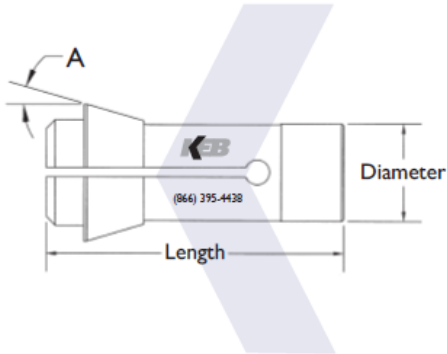

1. Standard Collets are manufactured to .0005 TIR.
2. All Collets 1/2" and larger are serrated.
3. Serrations are available on Collets under 1/2". See the Customs Tab or call for details.
4. Please specify smooth bore, if required, when ordering Pick-Off Collets.
5. Keyways are available upon request.
6. Please specify "EN" when ordering Extended Nose Collets. See the Customs Tab or call for more details.

TYPE	KEB FAMILY NO.	DIMENSION			INCREMENT	STOCK RANGE
		DIAMETER	LENGTH	ANGLE		
MCI8579						
MCI8579						
ROUND FRACTIONAL	C18579-117-SIZE	18MM 0.708	64MM 2.520	16°	1/32	1/8 to 1/2
ROUND DECIMAL	C18579-118-SIZE	18MM 0.708	64MM 2.520	16°	0.001	0.050 to 0.505