

COLLETS

MC20-201

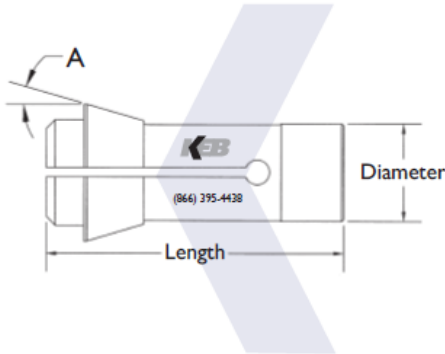

1. Standard Collets are manufactured to .0005 TIR.
2. All Collets 1/2" and larger are serrated.
3. Serrations are available on Collets under 1/2". See the Customs Tab or call for details.
4. Please specify smooth bore, if required, when ordering Pick-Off Collets.
5. Keyways are available upon request.
6. Please specify "EN" when ordering Extended Nose Collets. See the Customs Tab or call for more details.

TYPE	KEB FAMILY NO.	DIMENSION			INCREMENT	STOCK RANGE
		DIAMETER	LENGTH	ANGLE		
MC20-201						
MC20-201						
ROUND FRACTIONAL	C20201-117-SIZE	20MM 0.787	54MM 2.126	15°	1/32	1/16 to 5/8
ROUND DECIMAL	C20201-118-SIZE	20MM 0.787	54MM 2.126	15°	0.001	0.062 to 0.630
HEXAGON FRACTIONAL	C20201-127-SIZE	20MM 0.787	54MM 2.126	15°	1/16	1/8 to 1/2
SQUARE FRACTIONAL	C20201-137-SIZE	20MM 0.787	54MM 2.126	15°	1/16	1/8 to 7/16