

# COLLETS

## MC48/B42

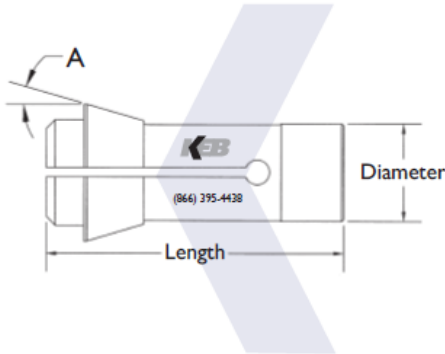

1. Standard Collets are manufactured to .0005 TIR.
2. All Collets 1/2" and larger are serrated.
3. Serrations are available on Collets under 1/2". See the Customs Tab or call for details.
4. Please specify smooth bore, if required, when ordering Pick-Off Collets.
5. Keyways are available upon request.
6. Please specify "EN" when ordering Extended Nose Collets. See the Customs Tab or call for more details.

TYPE	KEB FAMILY NO.	DIMENSION			INCREMENT	STOCK RANGE
		DIAMETER	LENGTH	ANGLE		
<b>MC48/B42</b>						
<b>MC48</b>						
ROUND FRACTIONAL	C48-117-SIZE	48MM 1.889	94MM 3.700	15°	1/16	3/8 to 1 1/2
ROUND DECIMAL	C48-118-SIZE	48MM 1.889	94MM 3.700	15°	0.001	0.300 to 1.500
HEXAGON FRACTIONAL	C48-127-SIZE	48MM 1.889	94MM 3.700	15°	1/16	3/8 to 1 1/4
SQUARE FRACTIONAL	C48-137-SIZE	48MM 1.889	94MM 3.700	15°	1/16	3/8 to 1