



INVICTA®

INVICTA FASTENERS



INDEX

QUALITY CONTROL AND TESTING.....2-3

MANUFACTURING PROCESS.....4

HEX-HEAD BOLTS.....5

SOCKET-HEAD BOLTS.....6

CARRIAGE BOLTS.....7

SPECIAL BOLTS.....8

STUDS.....9

U-BOLTS (DIN3570).....10

RIVETS.....11

STANDARD NUTS / MUTTERN.....12-14

OTHER BOLTS.....15

THREADED ROD DIN-975.....16

WASHERS.....17

DOWEL PINS CLEVIS PINS.....18

SCREW.....19-20

OTHER FASTENER CATEGORY.....21

ANCHORS FASTENERS.....22

SPIRAL RETAINING RING.....23

EYE BOLT.....24

WHEEL BOLT.....25

FASTENER ASSORTMENT KITS.....26

CONTACT INFORMATION.....27

OUR PRODUCTS

WE ARE ONE OF THE FASTEST GROWING MANUFACTURERS OF 4.6,4.8,5.8,8,8.8,9.8,10.9,12.9, GRADE IN M.S EN8D, HIGH TENSILE,BORON, STAINLESS STEEL & ALUMINUM, COLD FORGED FASTENERS,COLD FORGED SHOULDER BOLTS, SPECIAL BOLTS, STEP BOLTS, RIVETS & ALL TYPE OF COLD FORGED COMPONENTS WITH SIZE RANGING FORM M3 TO M16.OUR SPECIALTY LIES IN PRODUCING THESE COMPONENTS AS PER DRAWING AND CONFORMING TO NATIONAL AND INTERNATIONAL STANDARDS LIKE IS, DIN, BS, JIS AND U.S.

QUALITY PLOICY

WE ARE COMMITTED TO DELIVER HIGH QUALITY PRODUCTS AT RIGHT COST AND AT RIGHT TIME.

QUALITY ASSURANCE

WE ARE COMMITTED TOWARDS OFFERING OUR CLIENTS WITH A QUALITATIVE RANGE OF FASTNERS AND FORGED COMPONESTS.WE ENSURE TO MAINTAIN QUALALITY AT EACH LEVEL OF THE BUSINESS OPERATIONS.OUR IN-HOUSE QUALITY CONTROL LAB IS FULLY EQUIPPED TO CHECK THE QUALITY OF THE PRODUCTS RIGHT FROM THE PROCUREMENTS OF THE RAW MATERIAL TILL THE FINAL FINISH.CAPITALIZING ON OUR WIDE INDUSTRY EXPERIENCE, WE HAVE BEEN ABLE TO SATISFY OUR CLIENTS WITH THE PRODUCTS AS PER THEIR SEPCIFICATIONS AND REQUIREMENTS.

QUALITY CONTROL AND TESTING

- Magnetic Particle Inspection Machine
- Optical Inspection Machine, Dimensional Inspection
- Profile Projector
- Precision Measuring System (VMM)
- Salt Spray Tester
- Plating Thickness Testing
- Surface Roughness Tester
- Dimensional and Metallurgical Inspection Machine (Laser and Eddy Current Based)
- Rockwell Hardness Testers
- Spectrometer
- Metallurgical Microscope
- Brinell Hardness Tester
- Digital Rockwell cum superficial Hardness Tester
- Micro hardness tester with Image Analyzer
- Electronic Universal Testing Machine



MANUFACTURING PROCESS

- Wire Processing
- Tooling
- Cold Forging
- Thread Rolling
- Heat Treatment
- Hot Forging
- Machining
- Surface Treatment

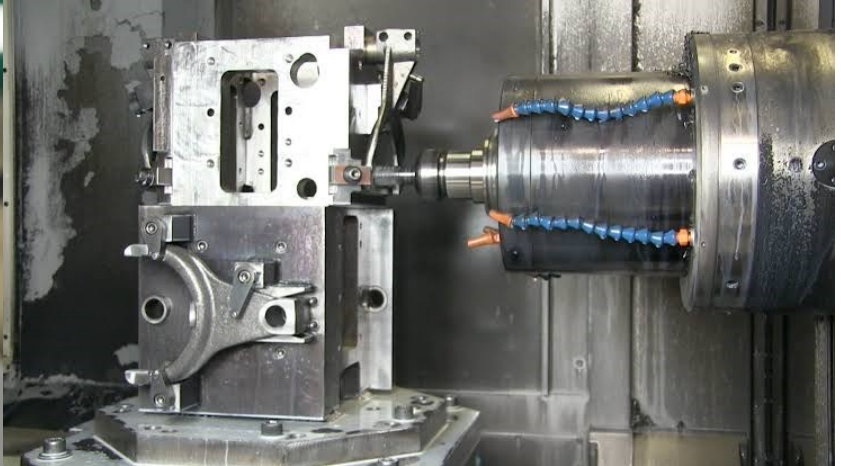

HEX-HEAD BOLTS

DIN Standards : DIN933 (Full Thread), DIN931 (Partial-Thread)

Diameter : M4 to M52

Grades : 8.8, 10.9, 12.9, 14.9, Stainless Steel A2, Stainless Steel A4

Length : 6mm to 600mm



SOCKET-HEAD BOLTS

Diameter : M4 to M52

DIN Standard :

Grades : 8.8, 10.9, 12.9, 14.9, Stainless Steel A2, Stainless Steel A4

Length : 6mm to 600mm



SOCKET HEAD CAP SCREWS

CARRIAGE BOLTS

DIN Standard : DIN603

Diameter : M4 to M52

Grades : 8.8, 10.9, 12.9, 14.9, Stainless Steel A2, Stainless Steel A4

Length : 6mm to 600mm



SPECIAL BOLTS

Produced as per customer specifications.



STUDS

Diameter : M6 to M100

Length : Upto 2000mm

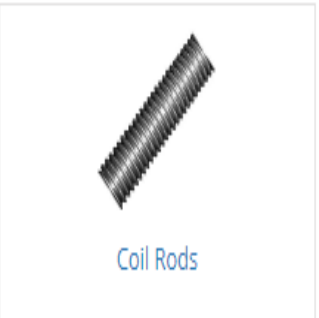

U-BOLTS (DIN3570)

Produced as per customer specifications.

Grades : 4.6, 5.6, 8.8, 10.9, 12.9, 14.9, Stainless Steel A2, Stainless Steel A4

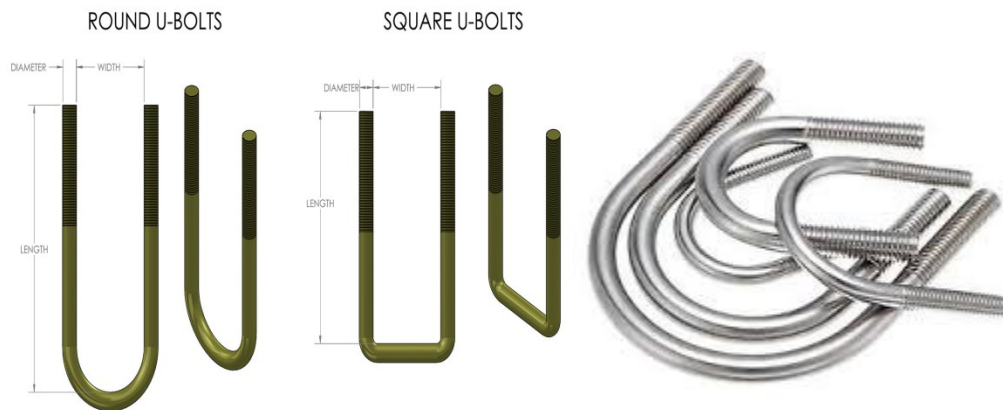

RIVETS

Produced as per customer specifications.

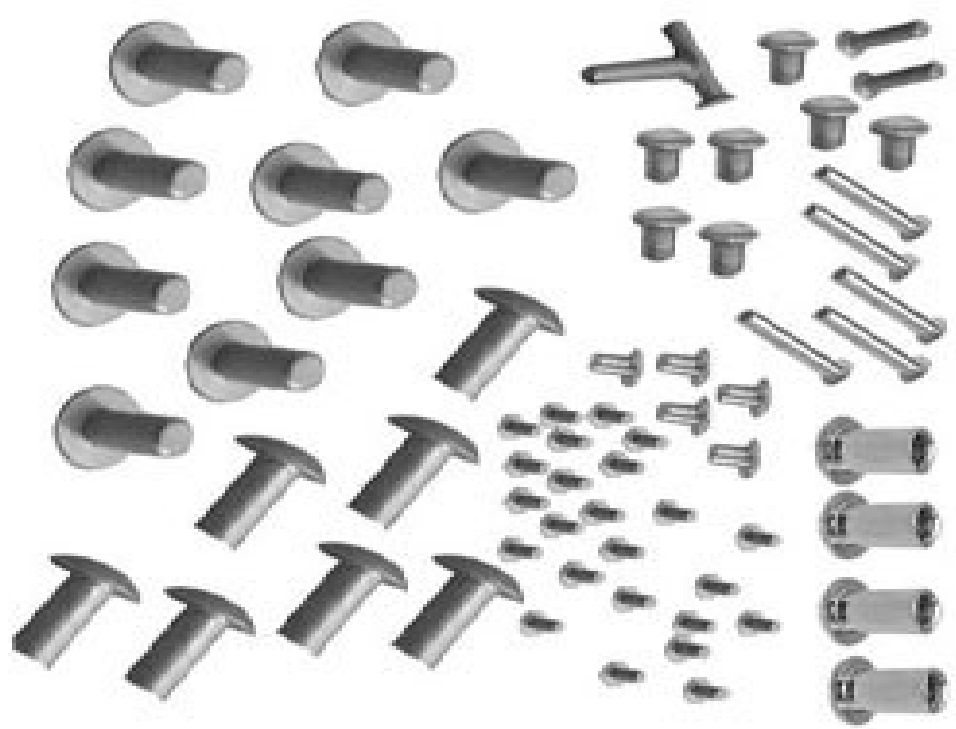

Blind Rivets



Rivet Nuts



Solid Rivets



Drive Rivets

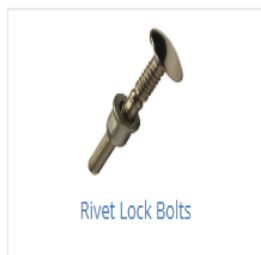

Rivet Lock Bolts



Rivet Collars



Rivet Back-Up Washers



Split Rivets

STANDARD NUTS / MUTTERN

| | |
|--|--|
| <p>DIN934 Hexagonal Nut</p> <p>Material : 8.8 Galvanised Steel, Stainless Steel A2, Stainless Steel A4, Brass, Nickel Plated, Raw Steel</p> |  |
| <p>DIN980</p> |  |
| <p>DIN6927</p> |  |
| <p>DIN14440 / DIN14441</p> |  |
| <p>DIN6923 / DIN EN 1661 DIAMETER : M4-M12 , 5/32-1/2"</p> |  |
| <p>DIN985,982 (Nylock Nut)</p> |  |

| | |
|--|--|
| <p>Stainless Steel Square Nut, DIN 557 Stainless Steel Square Nuts. Available in A2 / 304 and A4 / 316 Stainless Steel. All manufactured to DIN 557 standard.</p> |  |
| <p>Wing Nut</p> |  |
| <p>Weld nut DIN 928,929 DIAMETER : M4-M12. 5/32-1/2"</p> |  |
| <p>BRASS NUT</p> |  |
| <p>TEE NUT</p> |  |
| <p>DOOM NUT</p> |  |
| <p>CAGE NUTS</p> |  |
| <p>SLOTTED NUT</p> |  |



Imperial Brass Nuts



Imperial Nylon Locking Nuts



Imperial Steel Nuts (UNF)



Metric Brass Nuts



Metric Flanged Nuts



Metric Nylon Locking Nuts



Metric Steel Nuts (Coarse)



Metric Steel Nuts (Fine)



Hex Nuts



Lock Nuts



Flange Nuts



Wing Nuts



Slotted Nuts



Weld Nuts



Coupling Nuts



Acorn Nuts

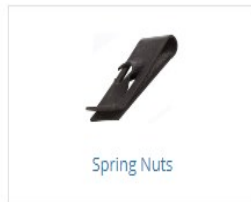

Spring Nuts



Square Nuts



Cage Nuts



Allenuts



Tee Nuts

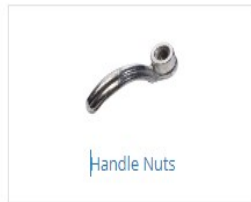

Handle Nuts



Palnuts



Push Nuts



Disc Nuts

OTHER BOLTS



SOCKET BUTTON HEAD SCREWS



HEXAGON FLANGE BOLTS DIN6921 (A2)



SOCKET HEAD COUNTERSUNK SCREWS DIN 7991 STAINLESS



SHOULDER BOLT



CYLINDER HEAD BOLT



ALLEN KEY

THREADED ROD DIN-975

TECHNICAL SPECIFICATION:

The company manufactures superior quality Threaded Rods that are used in a number of industrial as well as mechanical applications. Our Industrial Threaded Rods are specially designed to suit the specific requirements of the industry. We make them available in both standard as well as customized ranges. These treaded rods are fabricated from the best quality base materials such as stainless steel so that they become doubly durable and long lasting in nature. They have high tensile strengths that resist them from any abrasion for a longer period of time. Besides, we stand amidst the reliable Industrial Threaded Rods in Exporters.

Sizes : 6 mm to 30 mm

ASTM Size :

Diameter: 1/4" to 2"

Lengths: 1' to 12'

Tube Quantities: 1 to 50 depending on diameter

'''



WASHERS

TECHNICAL SPECIFICATION:

We are a distinguished manufacturer, supplier and exporter of a wide array of Washers. These washers are manufactured using high quality raw material. Our washers are acknowledged for their features like dimensional accuracy, corrosion resistance, low maintenance, durability, fine finish and easy installation. Due to these features, our products are used in automobile and engineering related industries. Our range includes Threaded Washers (Ring) Slotted, Brass Washers Nickel Plated, Brass Square Punched Washer, Brass Round Punched Washers

| | | |
|---|--|--|
| <p style="text-align: center;">BELL CRANK WASHER</p>  | <p style="text-align: center;">DIN 6916 WASHER</p>  | <p style="text-align: center;">CUP WASHER</p>  |
| <p style="text-align: center;">FENDER WASHER</p>  | <p style="text-align: center;">HUB BOLT WASHER</p>  | <p style="text-align: center;">DIN 9021 WASHER</p>  |
| <p style="text-align: center;">SPRING LOCK WASHER [DIN127]</p>  | <p style="text-align: center;">SQUARE WASHER</p>  | <p style="text-align: center;">DIN7349 WASHER</p>  |
| <p style="text-align: center;">ALUMINUM WASHER</p>  | <p style="text-align: center;">DIN 472 WASHER</p>  | <p style="text-align: center;">COPPER WASHER</p>  |
| <p style="text-align: center;">DOWTY WASHERS</p>  | <p style="text-align: center;">FIBER WASHERS</p>  | <p style="text-align: center;">BRASS WASHERS</p>  |
| <p style="text-align: center;">CANTER WASHERS</p>  | <p style="text-align: center;">SPECIAL NOZZLE WASHERS</p>  | <p style="text-align: center;">DIN 471 WASHER</p>  |

DOWEL PINS & CLEVIS PINS





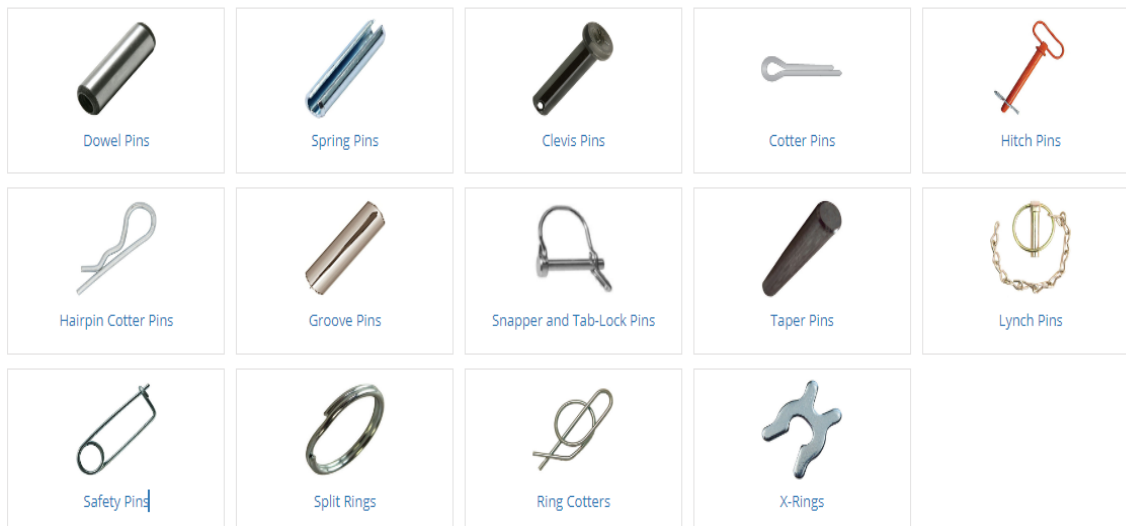





















| | |
|------------------------|---|
| LEAF SPRING PIN |  |
| Piston Pin |  |







SCREW



| | |
|--|---|
| <p>Coach screw</p> |  |
| <p>Grub Screw</p> |  |
| <p>Self Tapping Screw (DIN 7971,7972,7973,7976,7981,7982)</p> |  |
| <p>Number plate fixing screw</p> |  |
| <div style="display: flex; justify-content: space-around;"> <div data-bbox="240 1213 391 1283">  <p>Pan Head Pozzi Self Tapping</p> </div> <div data-bbox="423 1213 574 1283">  <p>Pan Head Slotted Tapping Screws</p> </div> <div data-bbox="607 1213 758 1283">  <p>Round Head BA Screws & Nuts</p> </div> </div> | <div style="display: flex; justify-content: space-around;"> <div data-bbox="813 1171 867 1331">  <p>Traditional Screw</p> </div> <div data-bbox="899 1171 953 1331">  <p>Production Screw</p> </div> <div data-bbox="985 1171 1039 1331">  <p>Drywall Screw</p> </div> <div data-bbox="1055 1171 1109 1331">  <p>Twinfast Threads</p> </div> <div data-bbox="1125 1171 1179 1331">  <p>Deep Threads</p> </div> <div data-bbox="1195 1171 1248 1331">  <p>Drywall Threads</p> </div> </div> |
| <p>Banjo Screw</p> |  |
| <p>Security Cap Screws</p> |  |

| | | | | |
|--|---|--|---|---|
|  Machine Screws |  Sheet Metal Screws |  Self-Drilling Screws |  Wood Screws |  Thread Cutting Screws |
|  Thread Rolling Screws |  Lag Screws |  Tamper-Resistant Screws |  SEMS Screws |  Drywall Screws |
|  Thumb Screws |  Eye Screws |  Drive Screws |  Binding Post Barrels |  Flooring Screws |
|  Wing Screws |  Weld Screws |  Dowel Screws |  Collated Screws |  Binding Post Mating Screws |
|  Binding Post Screw Sets |  Accordion Screws |  Euro Screws |  Timber Screws |  Jack Screws |

Set Screws



















| | | | | |
|--|---|--|--|--|
|  Socket Set Screws |  Square Head Set Screws |  Threadlockers |  Thread Sealants and Compounds |  Socket Jam Screws |
|--|---|--|--|--|

OTHER FASTENER CATEGORY

| | |
|---------------------------------|--|
| <p>Nails Fastener</p> |  |
| <p>Thread Inserts Fasteners</p> |  |
| <p>Guide rod</p> |  |

ANCHORS FASTENERS



| | | | | |
|--|--|---|--|--|
|  <p>Wedge Anchors</p> |  <p>Screw Anchors</p> |  <p>Threadlockers</p> |  <p>Wall Anchors</p> |  <p>Sleeve Anchors</p> |
|  <p>Thread Sealants and Compounds</p> |  <p>Drive Anchors</p> |  <p>Rod Anchors</p> |  <p>Drop-In Anchors</p> |  <p>Drive Pin Anchors</p> |
|  <p>Expansion Shield Anchors</p> |  <p>Bent Anchor Bolts</p> |  <p>Pre-Cast Inserts</p> |  <p>Shear Connectors and Headed Concrete Weld Studs</p> |  <p>Caulk-In Anchors</p> |
|  <p>Wall Anchor Kits</p> |  <p>Chemical Anchors</p> |  <p>Umbrella Anchors</p> |  <p>Stud Anchors</p> | |

Spiral Retaining Ring

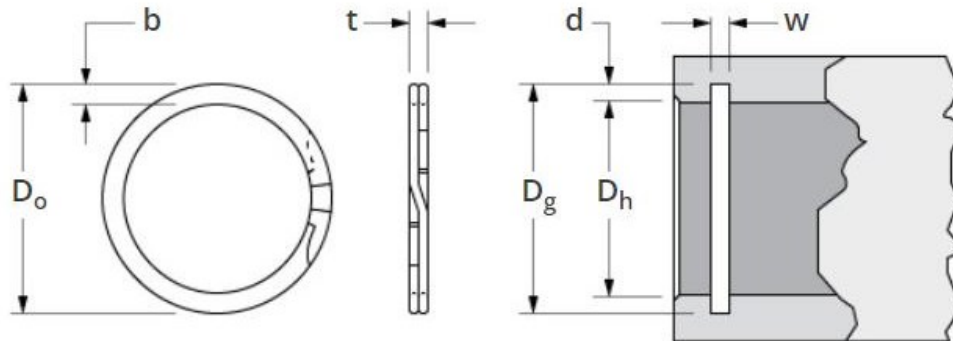

| | |
|------------------------------------|---|
| Ring Type | Internal Ring |
| D_h : Housing Diameter (in) | 3.562 |
| D_g : Groove Diameter (in) | 3.756 +/- .006 |
| w: Groove Width (in) | 0.120 +.005/- .000 |
| D_o : Free Outside Diameter (in) | 3.783 +.030/- .000 |
| t: Ring Thickness (in) | 0.111 +/- .003 |
| b: Ring Radial Wall (in) | 0.250 +/- .005 |
| # of Turns | 2 |
| Crimp | Yes |
| Ring Shear (lb) | 49690 (safety factor of 3) |
| Groove Yield (lb) | 24420 (groove material yield strength of 45,000 psi and safety factor of 2) |



External Retaining Rings



Internal Retaining Rings



E-Clips



Internal Spiral Rings



External Crescent Rings



Retaining Ring Kits



Internal Push-On Rings



External Push-On Rings



External Spiral Rings



External Interlocking Rings



E-Clip Kits



External Poodle Rings



Support Rings



Round Retaining Rings

EYE BOLT

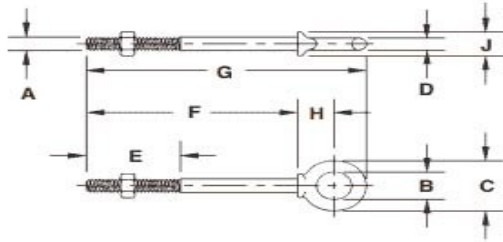

| Shank Diameter & Length (in.) | G-277 Stock No. Galv. | Working Load Limit* (lbs.) | Weight Per 100 (lbs.) | Dimensions (in.) | | | | | | | | |
|-------------------------------|-----------------------|----------------------------|-----------------------|------------------|------|------|------|------|-------|-------|------|------|
| | | | | A | B | C | D | E | F | G | H | J |
| 1/4 x 2 | 1045014 | 650 | 6.60 | .25 | .50 | .88 | .19 | 1.50 | 2.00 | 2.94 | .50 | .47 |
| 1/4 x 4 | 1045032 | 650 | 9.10 | .25 | .50 | .88 | .19 | 2.50 | 4.00 | 4.94 | .50 | .47 |
| 5/16 x 2 1/4 | 1045050 | 1200 | 12.50 | .31 | .62 | 1.12 | .25 | 1.50 | 2.25 | 3.50 | .69 | .56 |
| 5/16 x 4 1/4 | 1045078 | 1200 | 18.80 | .31 | .62 | 1.12 | .25 | 2.50 | 4.25 | 5.50 | .69 | .56 |
| 3/8 x 2 1/2 | 1045096 | 1550 | 21.40 | .38 | .75 | 1.38 | .31 | 1.50 | 2.50 | 3.97 | .78 | .66 |
| 3/8 x 4 1/2 | 1045112 | 1550 | 25.30 | .38 | .75 | 1.38 | .31 | 2.50 | 4.50 | 5.97 | .78 | .66 |
| 1/2 x 3 1/4 | 1045130 | 2600 | 42.60 | .50 | 1.00 | 1.75 | .38 | 1.50 | 3.25 | 5.12 | 1.00 | .91 |
| 1/2 x 6 | 1045158 | 2600 | 56.60 | .50 | 1.00 | 1.75 | .38 | 3.00 | 6.00 | 7.88 | 1.00 | .91 |
| 5/8 x 4 | 1045176 | 5200 | 68.60 | .62 | 1.25 | 2.25 | .50 | 2.00 | 4.00 | 6.44 | 1.31 | 1.12 |
| 5/8 x 6 | 1045194 | 5200 | 102.40 | .62 | 1.25 | 2.25 | .50 | 3.00 | 6.00 | 8.44 | 1.31 | 1.12 |
| 3/4 x 4 1/2 | 1045210 | 7200 | 144.50 | .75 | 1.50 | 2.75 | .62 | 2.00 | 4.50 | 7.44 | 1.56 | 1.38 |
| 3/4 x 6 | 1045238 | 7200 | 167.50 | .75 | 1.50 | 2.75 | .62 | 3.00 | 6.00 | 8.94 | 1.56 | 1.38 |
| 7/8 x 5 | 1045256 | 10600 | 225.00 | .88 | 1.75 | 3.25 | .75 | 2.50 | 5.00 | 8.47 | 1.84 | 1.56 |
| 1 x 6 | 1045292 | 13300 | 366.30 | 1.00 | 2.00 | 3.75 | .88 | 3.00 | 6.00 | 9.97 | 2.09 | 1.81 |
| 1 x 9 | 1045318 | 13300 | 422.50 | 1.00 | 2.00 | 3.75 | .88 | 4.00 | 9.00 | 12.97 | 2.09 | 1.81 |
| 1 1/4 x 8 | 1045336 | 21000 | 650.00 | 1.25 | 2.50 | 4.50 | 1.00 | 4.00 | 8.00 | 12.72 | 2.47 | 2.28 |
| 1 1/4 x 12 | 1045354 | 21000 | 795.00 | 1.25 | 2.50 | 4.50 | 1.00 | 4.00 | 12.00 | 16.72 | 2.47 | 2.28 |
| 1 1/2 x 15 | 1045372 | 24000 | 1425.00 | 1.50 | 3.00 | 5.50 | 1.25 | 6.00 | 15.00 | 20.75 | 3.00 | 2.75 |

*Ultimate Load is 5 times the Working Load Limit.

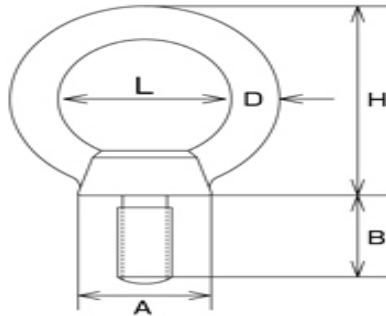

Metric Thread SUS304

(mm)

| Item Code | D | L | H | B | A | Thrd. | Wt. (g) | WLL | |
|-------------|------|------|------|----|----|-------|---------|-------|------|
| | | | | | | | | (kgf) | (kN) |
| IBF-6M | 5 | 14.5 | 26.5 | 14 | 13 | M-6 | 18 | 50 | 0.49 |
| IBF-8M | 6.3 | 20 | 33.3 | 15 | 16 | M-8 | 33 | 80 | 0.78 |
| IBF-10M | 8 | 25 | 41.5 | 18 | 20 | M-10 | 70 | 150 | 1.47 |
| IBF-12M | 10 | 30 | 51 | 22 | 25 | M-12 | 125 | 220 | 2.16 |
| NEW IBF-14M | 12.5 | 35 | 60 | 27 | 30 | M-14 | 220 | 330 | 3.23 |
| IBF-16M | 12.5 | 35 | 60 | 27 | 30 | M-16 | 220 | 450 | 4.41 |
| NEW IBF-18M | 16 | 40 | 71 | 30 | 35 | M-18 | 370 | 540 | 5.29 |
| IBF-20M | 16 | 40 | 71 | 30 | 35 | M-20 | 380 | 630 | 6.18 |
| NEW IBF-22M | 18 | 45 | 81 | 35 | 40 | M-22 | 575 | 800 | 7.84 |
| IBF-24M | 20 | 50 | 90 | 38 | 45 | M-24 | 760 | 950 | 9.31 |

WHEEL BOLT



Automotive Fasteners

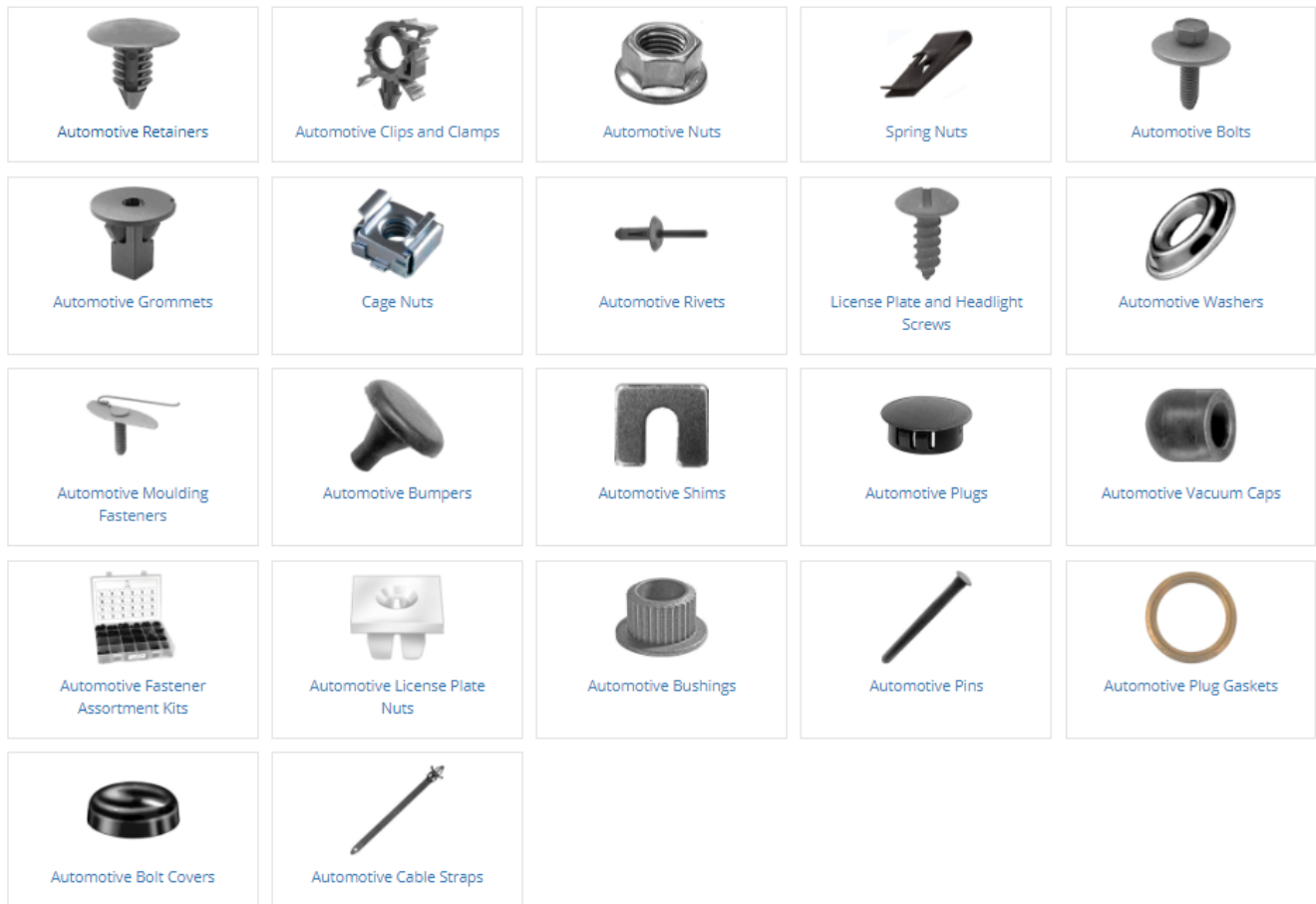

Fastener Assortment Kits

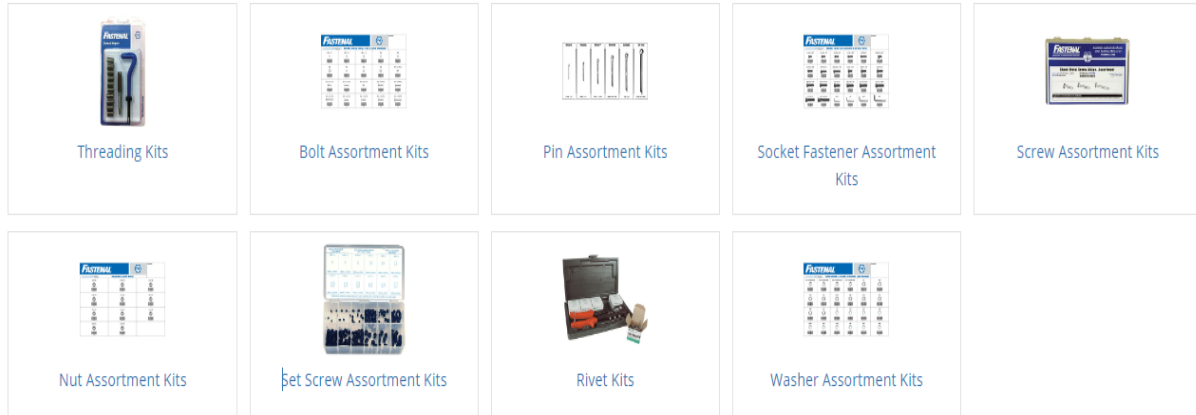

Thread locker

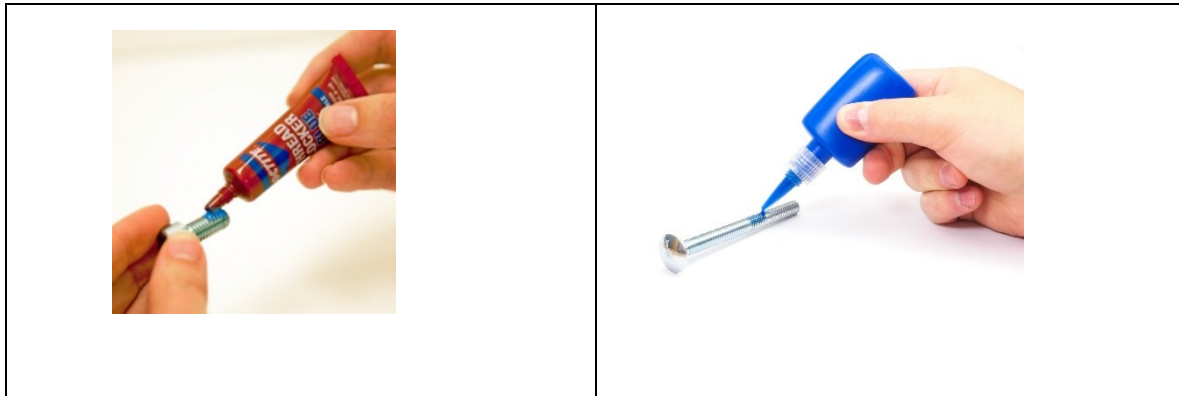

Thread Sealants and Compounds

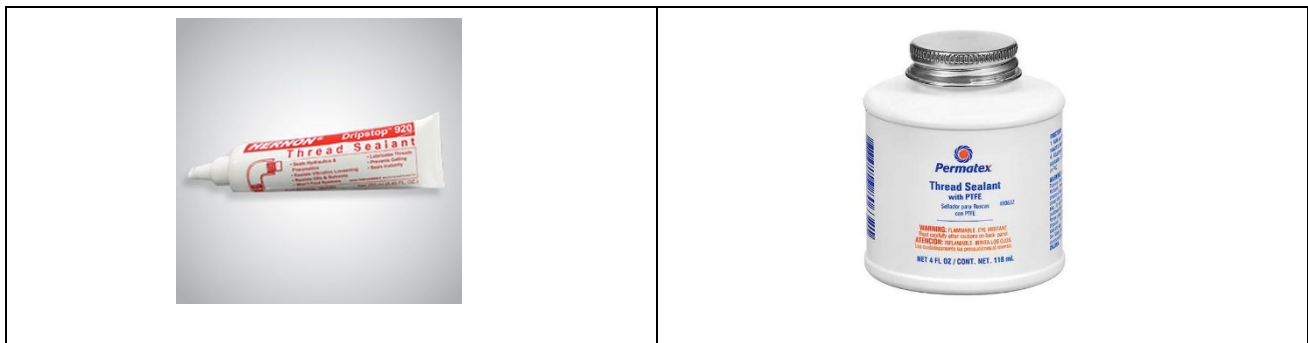

Double U bolts

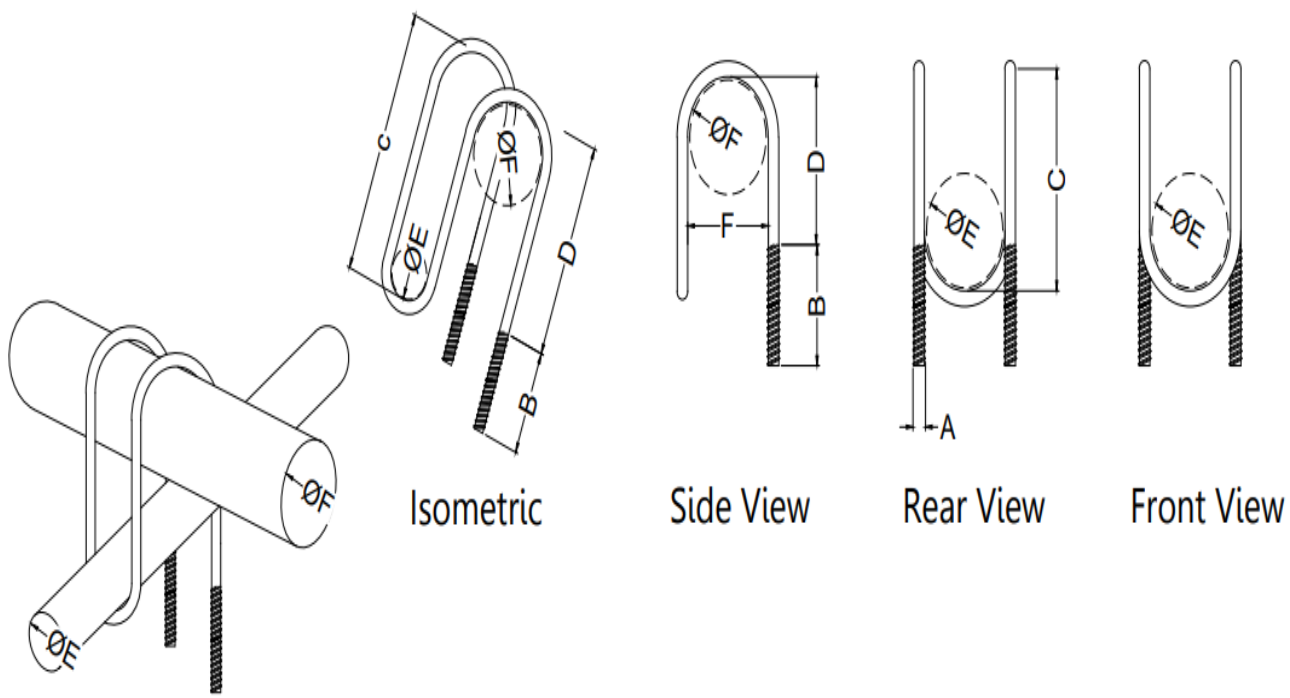

| PART REFERENCE | A | B | C | D | E Ø | F Ø |
|----------------|-----|------|-------|-------|------|------|
| 25.4 X 25.4mm | 8mm | 30mm | 52mm | 40mm | 27mm | 27mm |
| 35.0 X 25.4mm | 8mm | 30mm | 62mm | 50mm | 27mm | 37mm |
| 35.0 X 35.0mm | 8mm | 30mm | 72mm | 60mm | 37mm | 37mm |
| 45.0 X 45.0mm | 8mm | 30mm | 92mm | 80mm | 47mm | 47mm |
| 50.8 X 35.0mm | 8mm | 35mm | 87mm | 75mm | 37mm | 53mm |
| 50.8 X 50.8mm | 8mm | 35mm | 103mm | 90mm | 53mm | 53mm |
| 60.3 X 35.0mm | 8mm | 35mm | 97mm | 85mm | 37mm | 62mm |
| 60.3 X 45.0mm | 8mm | 35mm | 107mm | 95mm | 47mm | 62mm |
| 60.3 X 50.8mm | 8mm | 35mm | 113mm | 100mm | 53mm | 62mm |

- FINISH**
- Zinc and Yellow Mild Steel
 - Bright Zinc Mild Steel
 - Galvanised Mild steel
 - Geomet Mild Steel
 - Passivated Stainless Steel A2
 - Passivated Stainless Steel A4

CONTACT INFORMATION

Invicta India Pvt. Ltd.
N-258/B GK-1
New Delhi
India

REX Consolidated
80 DLF Industrial Area Phase 1
Faridabad Haryana-121003
India

© Copyright 2022 Invicta India Pvt. Ltd.

All information and data stated in this Product Range document has been compiled with utmost care. Nevertheless, Invicta accepts no liability for any errors, omissions or other inaccuracies contained herein. Subject to change without notice. Reprinting or reproduction, in whole or in part, including of photographs, illustrations or graphics, is not permitted without the prior written consent of Invicta India Pvt. Ltd.. We reserve all rights in connection with this document.

Any similarity or resemblance is unintended and is merely a coincidence.

The vehicle applications cited in this Product Range document may possibly be valid only up to the date printed on the last of the document. All references made in this Product Range document to the item numbers of vehicle manufacturers and/or competitors are provided for the purpose of comparison only. Such information is not allowed to be used in invoices issued to vehicle owners.

For enquiries, please email us : rahul@invictaindia.com

All drawings & illustrations are the property right of INVICTA and cannot be copied, duplicated or reprinted in any form without the prior written consent from INVICTA

Invicta Copyright © 2022
All Right Reserved