

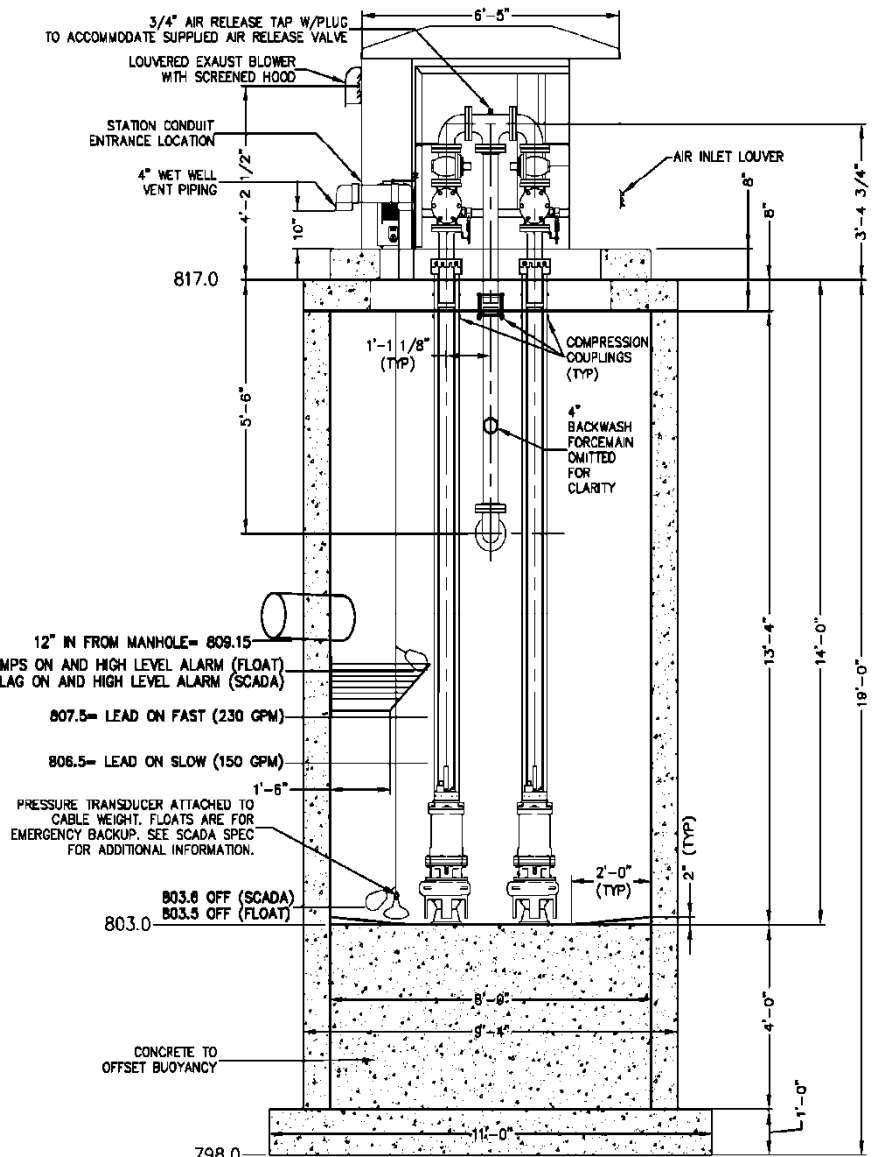

### Munters Lift Station – Buena Vista, VA

- Design of 230 gpm slide-rail submersible pump station to serve industrial park and new flow from outside source
- Duplex 30 horsepower pumps
- Replaced 40+ year old facility
- SCADA functionality
- Permitting
- Bidding
- Construction Phase Services



MUNTERS LIFT STATION FRONT SECTION

1/2" = 1'