

B11 Channel, combinations & load data

B11

- Thickness: 12 Gauge (2.6 mm)
- Standard lengths: 10' (3.05 m) & 20' (6.09 m)
- Standard finishes: Plain, DURA GREEN™, Pre-Galvanized, Hot-Dipped Galvanized, Aluminum
- Weight: 3.05 Lbs./Ft. (4.54 kg/m)

Note:

Aluminum loading, for B11, can be determined by multiplying load data times a factor of 0.38

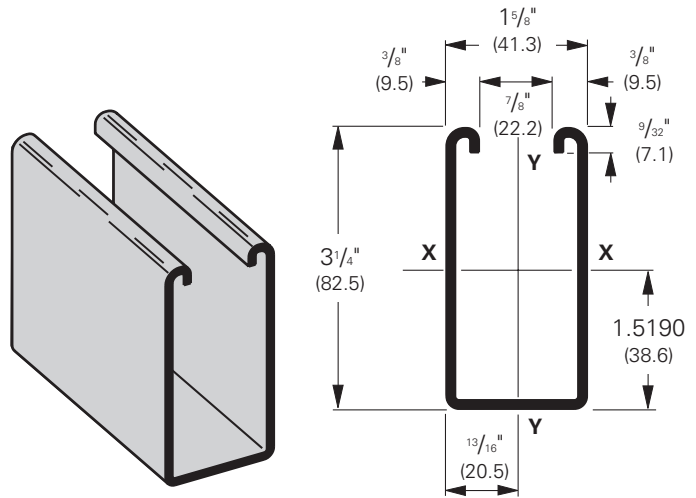

Section Properties			X - X Axis			Y - Y Axis		
Channel	Weight lbs./ft. kg/m	Areas of Section sq. in. cm ²	Moment of Inertia (I) in. ⁴ cm ⁴	Section Modulus (S) in. ³ cm ³	Radius of Gyration (r) in. cm	Moment of Inertia (I) in. ⁴ cm ⁴	Section Modulus (S) in. ³ cm ³	Radius of Gyration (r) in. cm
B11	3.059 (4.55)	.900 (5.81)	1.1203(46.63)	.6472 (10.61)	1.116 (2.83)	.4357(18.14)	.5362 (8.79)	.696 (1.77)
B11A	6.119 (9.11)	1.800(11.61)	6.3931(266.10)	1.9671(32.24)	1.885 (4.79)	.8714(36.27)	1.0725(17.58)	.696 (1.77)

Calculations of section properties are based on metal thicknesses as determined by the AISI Cold-Formed Steel Design Manual.

Beam Loading

Beam Span In. mm	Channel Style	Uniform Load and Deflection				Uniform Load @ Deflection =			
		Lbs.	kN	In.	mm	1/240 Span		1/360 Span	
						Lbs.	kN	Lbs.	kN
24 (609)	B11	5130	(22.82)	.029	(.73)	5130	(22.82)	5130	(22.82)
	B11A	5130*	(22.82)	.005	(.13)	5130*	(22.82)	5130*	(22.82)
36 (914)	B11	3488	(15.51)	.065	(1.65)	3488	(15.51)	3488	(15.51)
	B11A	5130*	(22.82)	.017	(.43)	5130*	(22.82)	5130*	(22.82)
48 (1219)	B11	2616	(11.63)	.117	(2.97)	2616	(11.63)	2616	(11.63)
	B11A	5130*	(22.82)	.040	(1.01)	5130*	(22.82)	5130*	(22.82)
60 (1524)	B11	2093	(9.31)	.183	(4.65)	2093	(9.31)	1908	(8.49)
	B11A	5130*	(22.82)	.079	(2.00)	5130*	(22.82)	5130*	(22.82)
72 (1829)	B11	1744	(7.76)	.263	(6.68)	1744	(7.76)	1325	(5.89)
	B11A	5130*	(22.82)	.136	(3.45)	5130*	(22.82)	5130*	(22.82)
84 (2133)	B11	1495	(6.65)	.358	(9.09)	1460	(6.49)	974	(4.33)
	B11A	4552	(20.25)	.191	(4.85)	4552	(20.25)	4552	(20.25)
96 (2438)	B11	1308	(5.82)	.468	(11.89)	1118	(4.97)	745	(3.31)
	B11A	3983	(17.72)	.250	(6.35)	3983	(17.72)	3983	(17.72)
108 (2743)	B11	1163	(5.17)	.592	(15.03)	884	(3.93)	589	(2.62)
	B11A	3541	(15.75)	.317	(8.05)	3541	(15.75)	3353	(14.91)
120 (3048)	B11	1046	(4.65)	.731	(18.57)	716	(3.18)	477	(2.12)
	B11A	3187	(14.17)	.391	(9.93)	3187	(14.17)	2716	(12.08)
144 (3657)	B11	872	(3.88)	1.053	(26.74)	497	(2.21)	331	(1.47)
	B11A	2656	(11.81)	.563	(14.30)	2656	(11.81)	1886	(8.39)
168 (4267)	B11	747	(3.32)	1.433	(36.40)	365	(1.62)	243	(1.08)
	B11A	2276	(10.12)	.766	(19.45)	2078	(9.24)	1386	(6.16)
192 (4877)	B11	654	(2.91)	1.871	(47.52)	280	(1.24)	186	(0.83)
	B11A	1992	(8.86)	1.001	(25.42)	1591	(7.08)	1061	(4.72)
216 (5486)	B11	581	(2.58)	2.368	(60.15)	221	(0.98)	147	(0.65)
	B11A	1770	(7.87)	1.267	(32.18)	1257	(5.59)	838	(3.73)
240 (6096)	B11	523	(2.32)	2.924	(74.27)	179	(0.79)	119	(0.53)
	B11A	1593	(7.08)	1.564	(39.72)	1018	(4.53)	679	(3.02)

Based on simple beam condition using an allowable design stress of 25,000 psi (172 MPa) in accordance with MFMA, with adequate lateral bracing (see page 12 for further explanation). Actual yield point of cold rolled steel is 42,000 psi (289 MPa). To determine concentrated load capacity at mid span, multiply uniform load by 0.5 and corresponding deflection by 0.8. *Failure determined by weld shear.

Reference page 48 for general fitting and standard finish specifications.

B11 Beam & column loading data

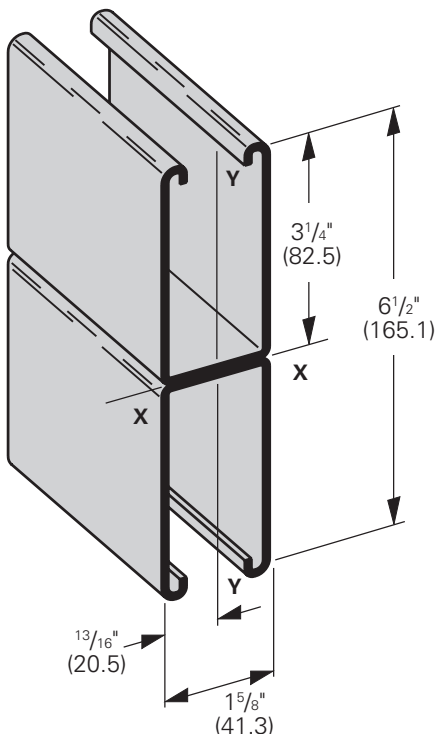

B11A
Wt. 6.10 Lbs./Ft. (9.08 kg/m)

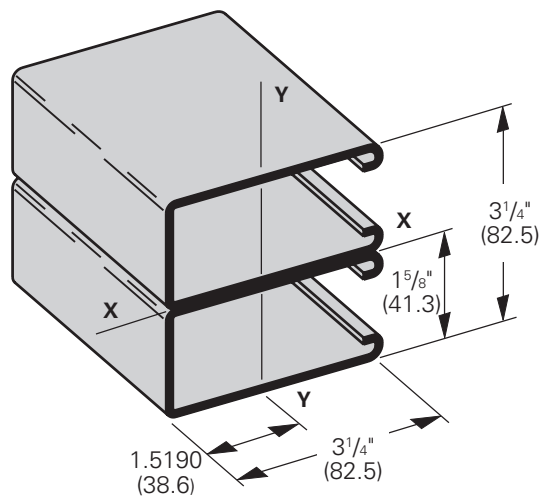

B11B
Wt. 6.10 Lbs./Ft. (9.08 kg/m)

Column Loading

Unbraced Height In. mm	Channel Style	Max. Column Loading K = .80				Max. Column Loading (Loaded @ C.G.)					
		Loaded@ C.G.		Loaded@ Slot Face		K = .65		K = 1.0		K = 1.2	
		Lbs.	kN	Lbs.	kN	Lbs.	kN	Lbs.	kN	Lbs.	kN
24 (609)	B11	8190	(36.43)	4477	(19.91)	8446	(37.57)	7783	(34.62)	7311	(32.52)
	B11A	17701	(78.74)	8267	(36.77)	17778	(79.08)	17572	(78.16)	17416	(77.47)
36 (914)	B11	7311	(32.52)	4183	(18.61)	7838	(34.86)	6503	(28.93)	5612	(24.96)
	B11A	17416	(77.47)	8189	(36.42)	17590	(78.24)	17127	(76.18)	16774	(74.61)
48 (1219)	B11	6214	(27.64)	3783	(16.83)	7053	(31.37)	4988	(22.19)	3816	(16.97)
	B11A	17016	(75.69)	8079	(35.94)	17327	(77.07)	16503	(73.41)	15876	(70.62)
60 (1524)	B11	4988	(22.19)	3279	(14.58)	6140	(27.31)	3595	(15.99)	2790	(12.41)
	B11A	16503	(73.41)	7727	(34.37)	16988	(75.56)	15701	(69.84)	14721	(65.48)
72 (1829)	B11	3816	(16.97)	2444	(10.87)	5146	(22.89)	2790	(12.41)	2213	(9.84)
	B11A	15876	(70.62)	6160	(27.40)	16574	(73.72)	14721	(65.48)	13310	(59.20)
84 (2133)	B11	3063	(13.62)	1897	(8.44)	4133	(18.38)	2291	(10.19)	1846	(8.21)
	B11A	15135	(67.32)	4961	(22.07)	16084	(71.54)	13563	(60.33)	11642	(51.78)
96 (2438)	B11	2564	(11.40)	1532	(6.81)	3398	(15.11)	1953	(8.69)	1591	(7.08)
	B11A	14279	(63.51)	4045	(17.99)	15520	(69.03)	12226	(54.38)	9717	(43.22)
108 (2743)	B11	2213	(9.84)	1273	(5.66)	2886	(12.84)	1708	(7.60)	1401	(6.23)
	B11A	13310	(59.20)	3337	(14.84)	14880	(66.19)	10712	(47.65)	7725	(34.36)
120 (3048)	B11	1953	(8.69)	1081	(4.81)	2514	(11.18)	1522	(6.77)	1251**	(5.56)
	B11A	12226	(54.38)	2784	(12.38)	14164	(63.00)	9019	(40.12)	6257**	(27.83)
144 (3657)	B11	1591	(7.08)	816	(3.63)	2011	(8.94)	1251**	(5.56)	1026**	(4.56)
	B11A	9717	(43.22)	1990	(8.85)	12508	(55.64)	6257**	(27.83)	4345**	(19.33)
168 (4267)	B11	1347	(5.99)	642	(2.85)	1687	(7.50)	1058**	(4.70)	859**	(3.82)
	B11A	7183	(31.95)	1464	(6.51)	10550	(46.93)	4597**	(20.45)	3192**	(14.20)
192 (4877)	B11	1167**	(5.19)	519	(2.31)	1459	(6.49)	910**	(4.05)	-	-
	B11A	5499**	(24.46)	1121	(4.98)	8330	(37.05)	3520**	(15.66)	-	-
216 (5486)	B11	1026**	(4.56)	429	(1.91)	1285**	(5.71)	-	-	-	-
	B11A	4345**	(19.33)	885	(3.93)	6582**	(29.28)	-	-	-	-
40 (6096)	B11	910**	(4.05)	360	(1.60)	1148**	(5.10)	-	-	-	-
	B11A	3520**	(15.66)	717	(3.19)	5331**	(23.71)	-	-	-	-

**Where the slenderness ratio $\frac{KL}{r}$ exceeds 200, and K = end fixity factor, L = actual length and r = radius of gyration.

Reference page 48 for general fitting and standard finish specifications.