

B24 Channel & combinations

B24

- Thickness: 14 Gauge (1.9 mm)
- Standard lengths: 10' (3.05 m) & 20' (6.09 m)
- Standard finishes: Plain, DURA GREEN™, Pre-Galvanized, Hot-Dipped Galvanized, Stainless Steel Type 304 or 316
- Weight: 1.40 Lbs./Ft. (2.08 kg/m)

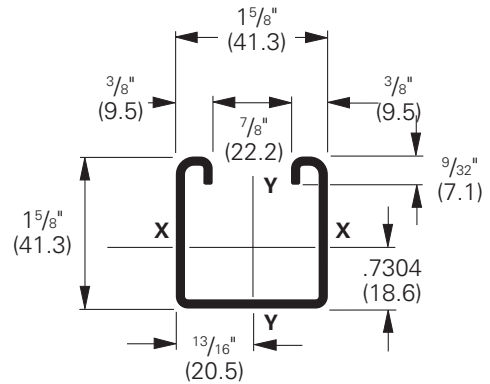
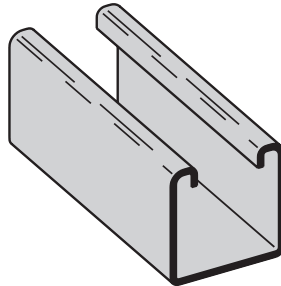

Section Properties			X - X Axis			Y - Y Axis		
Channel	Weight lbs./ft. kg/m	Areas of Section sq. in. cm ²	Moment of Inertia (I) in. ⁴ cm ⁴	Section Modulus (S) in. ³ cm ³	Radius of Gyration (r) in. cm	Moment of Inertia (I) in. ⁴ cm ⁴	Section Modulus (S) in. ³ cm ³	Radius of Gyration (r) in. cm
B24	1.442 (2.15)	.424 (2.74)	.1494 (6.22)	.1670 (2.74)	.594 (1.51)	.1857 (7.73)	.2286 (3.75)	.662 (1.68)
B24A	2.884 (4.29)	.848 (5.47)	.7514 (31.28)	.4624 (7.58)	.941 (2.39)	.3713 (15.45)	.4570 (7.49)	.662 (1.68)

Calculations of section properties are based on metal thicknesses as determined by the AISI Cold-Formed Steel Design Manual.

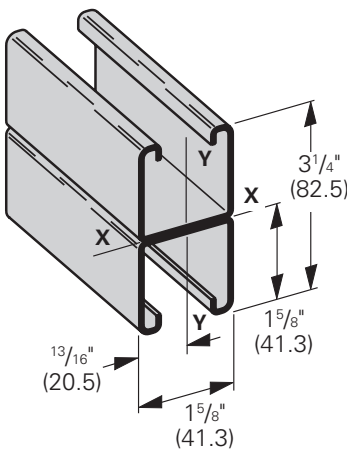

B24A
Wt. 2.80 Lbs./Ft. (4.16 kg/m)

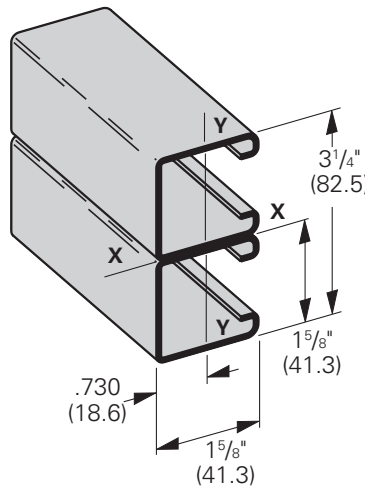

B24B
Wt. 2.80 Lbs./Ft. (4.16 kg/m)

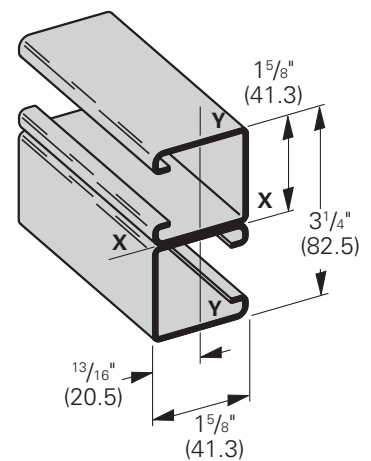

B24C
Wt. 2.80 Lbs./Ft. (4.16 kg/m)

Reference page 48 for general fitting and standard finish specifications.

B24 Beam & column loading data

Beam Loading

Beam Span In. mm	Channel Style	Uniform Load and Deflection				Uniform Load @ Deflection =			
		Lbs.	kN	In.	mm	¹ / ₂₄₀ Span		¹ / ₃₆₀ Span	
						Lbs.	kN	Lbs.	kN
12 (305)	B24	1750	(7.78)	.014	(.35)	1750	(7.78)	1750	(7.78)
	B24A	1750*	(7.78)	.002	(.05)	1750*	(7.78)	1750*	(7.78)
24 (609)	B24	1379	(6.13)	.057	(1.45)	1379	(6.13)	1379	(6.13)
	B24A	1750*	(7.78)	.014	(.35)	1750*	(7.78)	1750*	(7.78)
36 (914)	B24	919	(4.09)	.128	(3.25)	919	(4.09)	720	(3.20)
	B24A	1750*	(7.78)	.048	(1.22)	1750*	(7.78)	1750*	(7.78)
48 (1219)	B24	689	(3.06)	.227	(5.76)	607	(2.70)	405	(1.80)
	B24A	1750*	(7.78)	.115	(2.92)	1750*	(7.78)	1750*	(7.78)
60 (1524)	B24	551	(2.45)	.355	(9.02)	389	(1.73)	259	(1.15)
	B24A	1518	(6.75)	.195	(4.95)	1518	(6.75)	1294	(5.75)
72 (1829)	B24	460	(2.04)	.511	(12.98)	270	(1.20)	180	(0.80)
	B24A	1265	(5.63)	.281	(7.14)	1265	(5.63)	898	(3.99)
84 (2133)	B24	394	(1.75)	.695	(17.65)	198	(0.88)	132	(0.59)
	B24A	1084	(4.82)	.383	(9.73)	990	(4.40)	660	(2.93)
96 (2438)	B24	345	(1.53)	.908	(23.06)	152	(0.67)	101	(0.45)
	B24A	949	(4.22)	.500	(12.70)	758	(3.37)	505	(2.24)
108 (2743)	B24	306	(1.36)	1.149	(29.18)	120	(0.53)	80	(0.35)
	B24A	843	(3.75)	.633	(16.08)	599	(2.66)	399	(1.77)
120 (3048)	B24	276	(1.23)	1.419	(36.04)	97	(0.43)	65	(0.29)
	B24A	759	(3.37)	.782	(19.86)	485	(2.16)	323	(1.44)

Based on simple beam condition using an allowable design stress of 25,000 psi (172 MPa) in accordance with MFMA, with adequate lateral bracing (see page 12 for further explanation). Actual yield point of cold rolled steel is 42,000 psi. To determine concentrated load capacity at mid span, multiply uniform load by 0.5 and corresponding deflection by 0.8. *Failure determined by weld shear.

Column Loading

Unbraced Height In. mm	Channel Style	Max. Column Loading K = .80				Max. Column Loading (Loaded @ C.G.)					
		Loaded@ C.G.		Loaded@ Slot Face		K = .65		K = 1.0		K = 1.2	
		Lbs.	kN	Lbs.	kN	Lbs.	kN	Lbs.	kN	Lbs.	kN
12 (305)	B24	6441	(28.65)	3077	(13.69)	6509	(28.95)	6330	(28.16)	6198	(27.57)
	B24A	13212	(58.77)	4988	(22.19)	13237	(58.88)	13171	(58.59)	13121	(58.36)
24 (609)	B24	5874	(26.13)	2896	(12.88)	6124	(27.24)	5483	(24.39)	5038	(22.41)
	B24A	12993	(57.79)	4924	(21.90)	13092	(58.23)	12828	(57.06)	12627	(56.17)
36 (914)	B24	5038	(22.41)	2619	(11.65)	5535	(24.62)	4302	(19.13)	3516	(15.64)
	B24A	12627	(56.17)	4819	(21.43)	12851	(57.16)	12256	(54.52)	11804	(52.51)
48 (1219)	B24	4043	(17.98)	2272	(10.10)	4800	(21.35)	3008	(13.38)	2324	(10.34)
	B24A	12115	(53.89)	4675	(20.79)	12512	(55.65)	11456	(50.96)	10651	(47.38)
60 (1524)	B24	3008	(13.38)	1873	(8.33)	3978	(17.69)	2200	(9.78)	1740	(7.74)
	B24A	11456	(50.96)	4020	(17.88)	12078	(53.72)	10427	(46.38)	9169	(40.78)
72 (1829)	B24	2324	(10.34)	1562	(6.95)	3123	(13.89)	1740	(7.74)	1397	(6.21)
	B24A	10651	(47.38)	3048	(13.56)	11546	(51.36)	9169	(40.78)	7358	(32.73)
84 (2133)	B24	1898	(8.44)	1340	(5.96)	2502	(11.13)	1444	(6.42)	1168	(5.19)
	B24A	9700	(43.15)	2362	(10.50)	10918	(48.56)	7683	(34.17)	5464	(24.30)
96 (2438)	B24	1608	(7.15)	1175	(5.22)	2089	(9.29)	1236	(5.50)	1000	(4.45)
	B24A	8602	(38.26)	1866	(8.30)	10194	(45.34)	6024	(26.79)	4184	(18.61)
108 (2743)	B24	1397	(6.21)	1046	(4.65)	1796	(7.99)	1078	(4.79)	870**	(3.87)
	B24A	7358	(32.73)	1498	(6.66)	9373	(41.69)	4760	(21.17)	3306	(14.70)
120 (3048)	B24	1236	(5.50)	942	(4.19)	1578	(7.02)	953**	(4.24)	764**	(3.40)
	B24A	6024	(26.79)	1216	(5.41)	8455	(37.61)	3856	(17.15)	2677**	(11.91)

**Where the slenderness ratio $\frac{KL}{r}$ exceeds 200, and K = end fixity factor, L = actual length and r = radius of gyration.

Reference page 48 for general fitting and standard finish specifications.