

B54 Channel & combinations

B54

- Thickness: 14 Gauge (1.9 mm)
- Standard lengths: 10' (3.05 m) & 20' (6.09 m)
- Standard finishes: Plain, DURA GREEN™, Pre-Galvanized, Hot-Dipped Galvanized, Stainless Steel Type 304 or 316, Aluminum
- Weight: .97 Lbs./Ft. (1.44 kg/m)

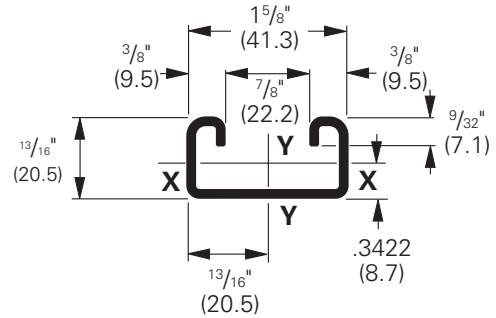
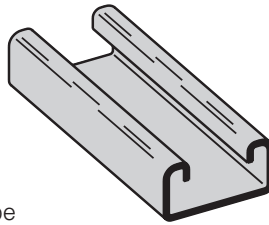

Note:

Aluminum loading, for B54 & B54A, can be determined by multiplying load data times a factor of 0.38

Section Properties			X - X Axis			Y - Y Axis		
Channel	Weight lbs./ft. kg/m	Areas of Section sq. in. cm ²	Moment of Inertia (I) in. ⁴ cm ⁴	Section Modulus (S) in. ³ cm ³	Radius of Gyration (r) in. cm	Moment of Inertia (I) in. ⁴ cm ⁴	Section Modulus (S) in. ³ cm ³	Radius of Gyration (r) in. cm
B54	1.016 (1.51)	.299 (1.93)	.0263 (1.09)	.0560 (.92)	.297 (.75)	.1106 (4.60)	.1361 (2.23)	.608 (1.55)
B54A	2.032 (3.02)	.598 (3.86)	.1226 (5.10)	.1510 (2.47)	.453 (1.15)	.2212 (9.12)	.2722 (4.46)	.608 (1.55)

Calculations of section properties are based on metal thicknesses as determined by the AISI Cold-Formed Steel Design Manual.

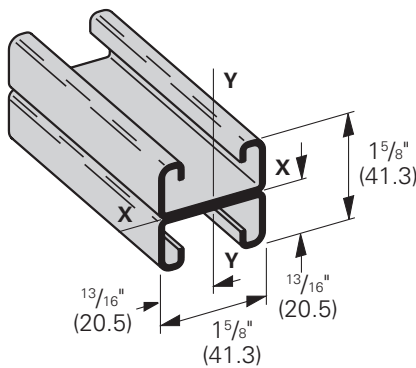

B54A

Wt. 1.94 Lbs./Ft. (2.89 kg/m)

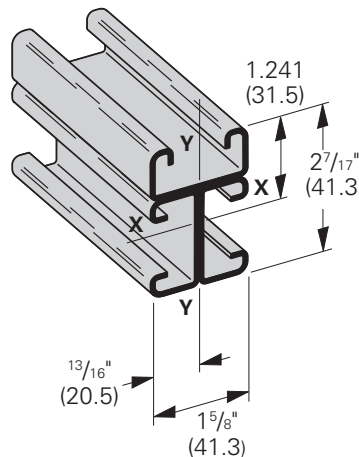

B54B3

Wt. 2.91 Lbs./Ft. (4.33 kg/m)

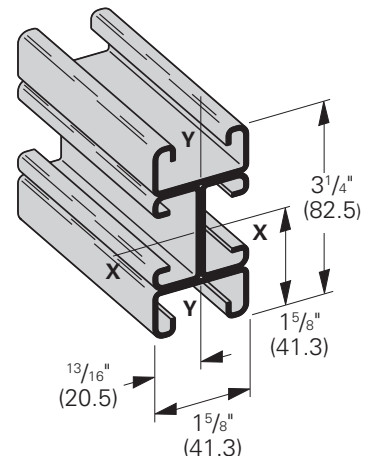

B54B4

Wt. 3.88 Lbs./Ft. (5.77 kg/m)

B54 Beam & column loading data

Beam Loading

Beam Span In. mm	Channel Style	Uniform Load and Deflection				Uniform Load @ Deflection =			
		Lbs.	kN	In.	mm	¹ / ₂₄₀ Span		¹ / ₃₆₀ Span	
		Lbs.	kN	In.	mm	Lbs.	kN	Lbs.	kN
12 (305)	B54	870	(3.87)	.027	(.68)	870	(3.87)	870	(3.87)
	B54A	870*	(3.87)	.005	(.13)	870*	(3.87)	870*	(3.87)
24 (609)	B54	465	(2.07)	.108	(2.74)	430	(1.91)	287	(1.27)
	B54A	870*	(3.87)	.043	(1.09)	870*	(3.87)	870*	(3.87)
36 (914)	B54	310	(1.38)	.243	(6.17)	191	(0.85)	127	(0.56)
	B54A	832	(3.70)	.141	(3.58)	832	(3.70)	591	(2.63)
48 (1219)	B54	233	(1.03)	.432	(10.97)	108	(0.48)	72	(0.32)
	B54A	624	(2.77)	.250	(6.35)	499	(2.22)	332	(1.48)
60 (1524)	B54	186	(0.83)	.676	(17.17)	69	(0.31)	46	(0.20)
	B54A	499	(2.22)	.391	(9.93)	319	(1.42)	213	(0.95)
72 (1829)	B54	155	(0.69)	.973	(24.71)	48	(0.21)	32	(0.14)
	B54A	416	(1.85)	.563	(14.30)	222	(0.99)	148	(0.66)
84 (2133)	B54	133	(0.59)	1.324	(33.63)	35	(0.15)	23	(0.10)
	B54A	357	(1.59)	.766	(19.45)	163	(0.72)	109	(0.48)
96 (2438)	B54	116	(0.51)	1.730	(43.94)	27	(0.12)	18	(0.08)
	B54A	312	(1.39)	1.001	(25.42)	125	(0.55)	83	(0.37)
108 (2743)	B54	103	(0.46)	2.189	(55.60)	21	(0.09)	14	(0.06)
	B54A	277	(1.23)	1.267	(32.18)	98	(0.43)	66	(0.29)
120 (3048)	B54	93	(0.41)	2.703	(68.65)	17	(0.07)	11	(0.05)
	B54A	250	(1.11)	1.564	(39.72)	80	(0.35)	53	(0.23)

Based on simple beam condition using an allowable design stress of 25,000 psi (172 MPa) in accordance with MFMA, with adequate lateral bracing (see page 12 for further explanation). Actual yield point of cold rolled steel is 42,000 psi. To determine concentrated load capacity at mid span, multiply uniform load by 0.5 and corresponding deflection by 0.8. *Failure determined by weld shear.

Column Loading

Unbraced Height In. mm	Channel Style	Max. Column Loading K = .80				Max. Column Loading (Loaded @ C.G.)					
		Loaded@ C.G.		Loaded@ Slot Face		K = .65		K = 1.0		K = 1.2	
		Lbs.	kN	Lbs.	kN	Lbs.	kN	Lbs.	kN	Lbs.	kN
12 (305)	B54	6186	(27.51)	2586	(11.50)	6284	(27.95)	6032	(26.83)	5857	(26.05)
	B54A	12763	(56.77)	4060	(18.06)	12835	(57.09)	12645	(56.25)	12501	(55.61)
24 (609)	B54	5464	(24.30)	2254	(10.02)	5763	(25.63)	4968	(22.10)	4300	(19.13)
	B54A	12135	(53.98)	3857	(17.16)	12420	(55.25)	11663	(51.88)	11087	(49.32)
36 (914)	B54	4300	(19.13)	1816	(8.08)	5043	(22.43)	3076	(13.68)	2136	(9.50)
	B54A	11087	(49.32)	3549	(15.79)	11728	(52.17)	10026	(44.60)	8729	(38.83)
48 (1219)	B54	2703	(12.02)	1341	(5.96)	3920	(17.44)	1730	(7.69)	1201	(5.34)
	B54A	9620	(42.79)	3169	(14.09)	10759	(47.86)	7734	(34.40)	5571	(24.78)
60 (1524)	B54	1730	(7.69)	995	(4.42)	2621	(11.66)	1107**	(4.92)	769**	(3.42)
	B54A	7734	(34.40)	2745	(12.21)	9514	(42.32)	5134	(22.84)	3566	(15.86)
72 (1829)	B54	1201	(5.34)	763	(3.39)	1820	(8.09)	769**	(3.42)	534**	(2.37)
	B54A	5571	(24.78)	2291	(10.19)	7992	(35.50)	3566	(15.86)	2476	(11.01)
84 (2133)	B54	883**	(3.93)	603	(2.68)	1337	(5.95)	565**	(2.51)	—	—
	B54A	4093	(18.20)	1913	(8.51)	6200	(27.58)	2620	(11.65)	1819**	(8.09)
96 (2438)	B54	676**	(3.01)	487	(2.16)	1024**	(4.55)	—	—	—	—
	B54A	3134	(13.94)	1616	(7.19)	4747	(21.11)	2006**	(8.92)	1393**	(6.19)
108 (2743)	B54	534**	(2.37)	401	(1.78)	809**	(3.60)	—	—	—	—
	B54A	2476	(11.01)	1380	(6.14)	3751	(16.68)	1585**	(7.05)	1100**	(4.89)
120 (3048)	B54	—	—	336	(1.49)	655**	(2.91)	—	—	—	—
	B54A	2006**	(8.92)	1190	(5.29)	3038	(13.51)	1284**	(5.71)	—	—

**Where the slenderness ratio $\frac{KL}{r}$ exceeds 200, and K = end fixity factor, L = actual length and r = radius of gyration.

Reference page 48 for general fitting and standard finish specifications.