

# Braces

## B261 - Two Hole 45° Knee Brace

- Standard finishes: ZN, GRN
- Design load determined by testing using a B335 hinged corner connection.
- Load ratings are for brace members only. Do not exceed allowable beam or column loads for strut channels.
- Safety Factor of 3

Part No.	A		B		Design Load		Wt./C	
	In.	mm	In.	mm	Lbs.	kN	Lbs.	kg
B261-8	8"	(203.2)	7 <sup>3</sup> / <sub>8</sub> "	(187.3)	1500	(6.67)	119	(54.0)
B261-12	12"	(304.8)	10 <sup>1</sup> / <sub>8</sub> "	(257.2)	1020	(4.54)	165	(74.8)
B261-16	16 <sup>5</sup> / <sub>8</sub> "	(422.3)	13 <sup>3</sup> / <sub>8</sub> "	(339.7)	530	(2.36)	218	(98.9)
B261-18	18"	(457.2)	14 <sup>7</sup> / <sub>16</sub> "	(366.7)	450	(2.00)	234	(106.1)
B261-24	24"	(609.6)	18 <sup>1</sup> / <sub>16</sub> "	(474.7)	250	(1.11)	303	(137.4)
B261-36	36"	(914.4)	27 <sup>3</sup> / <sub>16</sub> "	(690.6)	110	(.49)	441	(200.0)

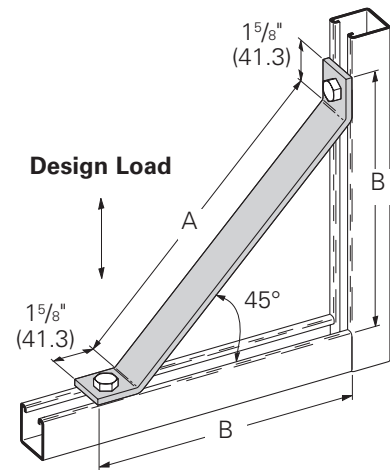

## B631 - Two Hole 45° Tubing Knee Brace

- 1" (25.4) Square steel tubing
- Material: ASTM A513
- Standard finishes: ZN, GRN
- Design load determined by testing using a B335 hinged corner connection.
- Load ratings are for brace members only. Do not exceed allowable beam or column loads for strut channels.
- Safety Factor of 3

Part No.	A		Design Load		Wt./C	
	In.	mm	Lbs.	kN	Lbs.	kg
B631-18	18"	(457.2)	1500	(6.67)	145	(65.8)
B631-24	24"	(609.6)	1500	(6.67)	186	(84.4)
B631-30	30"	(762.0)	1500	(6.67)	225	(102.0)
B631-36	36"	(914.4)	1500	(6.67)	266	(120.6)
B631-42	42"	(1066.8)	1230	(5.47)	307	(139.2)
B631-48	48"	(1219.2)	940	(4.18)	348	(157.8)
B631-54	54"	(1371.6)	740	(3.29)	389	(176.4)
B631-60	60"	(1524.0)	600	(2.67)	430	(195.0)
B631-72	72"	(1828.8)	420	(1.87)	508	(230.4)
B631-84	84"	(2133.6)	310	(1.38)	589	(267.2)
B631-96	96"	(2438.4)	240	(1.07)	669	(303.5)

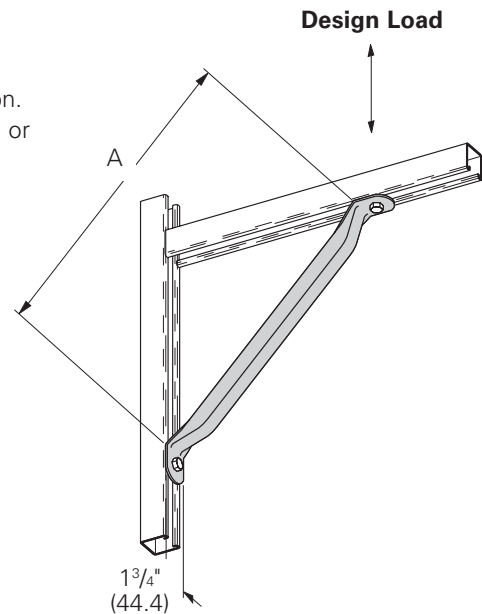

## B632 - Two Hole Straight Tubing Brace

- 1" (25.4) Square steel tubing
- Material: ASTM A513
- Standard finishes: ZN, GRN

Part No.	A		Wt./C	
	In.	mm	Lbs.	kg
B632-18	18"	(457.2)	133	(60.3)
B632-24	24"	(609.6)	174	(78.9)
B632-30	30"	(762.0)	215	(97.5)
B632-36	36"	(914.4)	256	(116.1)
B632-42	42"	(1066.8)	295	(133.8)
B632-48	48"	(1219.2)	335	(151.9)
B632-54	54"	(1371.6)	380	(172.3)
B632-60	60"	(1524.0)	420	(190.5)
B632-72	72"	(1828.8)	500	(226.8)
B632-84	84"	(2133.6)	585	(265.3)
B632-96	96"	(2438.4)	670	(303.9)

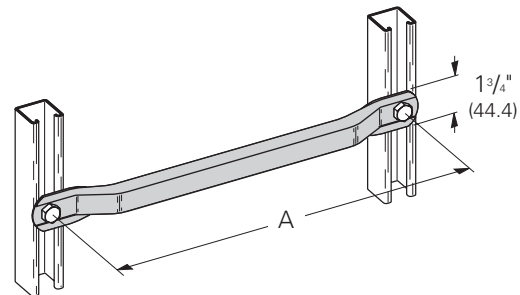

Reference page 106 for general fitting and standard finish specifications.