

Slotted angle kits and fittings

AHHK-1/4 & AHHK-3/8 Air Handler Hanging Kit

- Standard finishes: ZN
- Load Capacity Per Kit: 400 Lbs. (181.4 kg)

- ⑧ Hanging rods come in 72" lengths. Rods can be field cut for proper height requirement.

Item #	Description	Quantity	
		AHHK 1/4	AHHK 3/8
①	Rod Hanger Fitting	4	4
②	Lag Screw	4	4
③	Hex Head Cap Screw	4	4
④	Flat Washer (For HHCS)	4	4
⑤	Hex Nuts (For HHCS)	4	4
⑥	Hex Nuts (For Hanging Rods)	16	16
⑦	Flat Washer (See Note 1)	16	-
⑧	Hanging Rods (72" Long)	4	4
⑨	SA158 (36" Long)	2	2

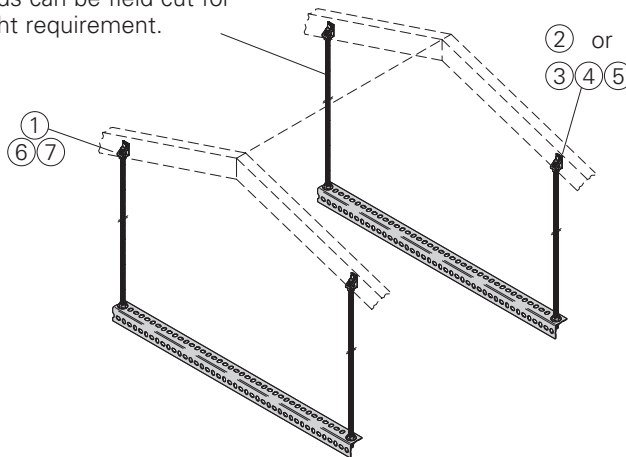

Note 1: Flat washers are required for 1/4"-20 hanging rods only.

SA101 Connection Plate

- Standard finishes: ZN, GRN
- Wt./C 67 Lbs. (30.4 kg)

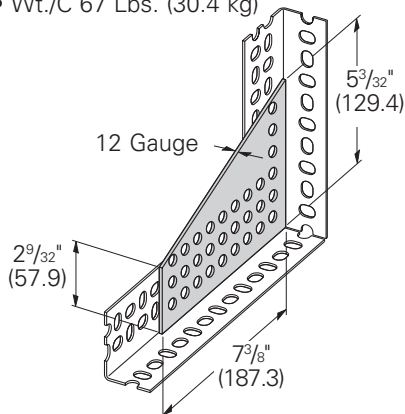

SA102 Angle Brace

- Standard finishes: ZN, GRN
- Wt./C 15 Lbs. (6.8 kg)

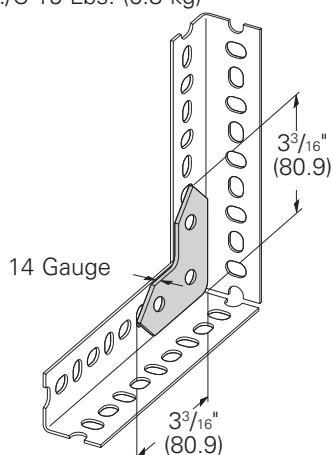

SA154 Rigid Caster

- Safety Factor of 1.5
- 300 Lbs. (136.1 kg) maximum load capacity
- Caster material: Phenolic
- Standard finishes: ZN, GRN
- Wt./Ea. 2.0 Lbs. (.91 kg)

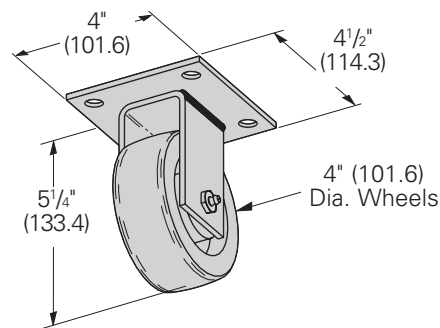

SA155 Swivel Caster

- Safety Factor of 1.5
- 300 Lbs. (136.1 kg) maximum load capacity
- Caster material: Phenolic
- Standard finishes: ZN, GRN
- Wt./Ea. 2.2 Lbs. (1.0 kg)

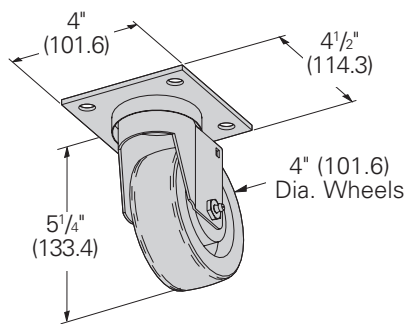

SA110 Slotted Angle Cutter

- Standard finishes:
- Wt./Ea. 16 Lbs. (7.26 kg)

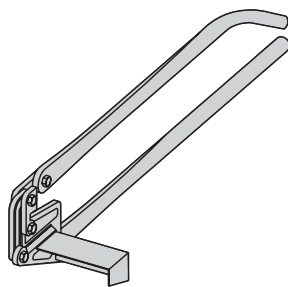

SA131 Slotted Strap

- Hole pattern is identical to the hole pattern in slotted angles
- Standard length: 10' (3.05 m)
- Standard finishes: Pre-Galv. (GALV)
- Material thickness: 14 gauge (1.9)

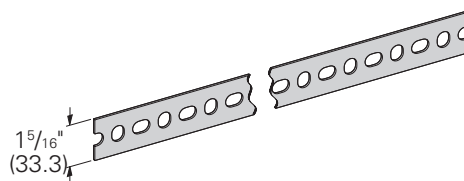

CLEATS: To reinforce load-bearing joints, cleats can be field made by cutting 2 1/4" (57.1) long segments from the widest slotted angle available.

Use SA276 for light duty cleats and SA318 for heavy duty cleats.

SPLICE PLATES: To assemble two pieces of slotted angle using a butt joint requires a 6" (152.4) splice plate for reinforcement.

Reference page 264 for general fitting and standard finish specifications.