



FIRED UP KILNS *and pottery supplies*



Slab Roller Owner's Manual

Last Updated: February 2024

Please take special note of the following:

- Read this manual **before** assembling & using your slab roller.
- **Contact us** if you have any questions or queries. We are always happy to help.
- **Do not overextend the movable tabletop**, injury to yourself and damage to the product may occur if you overextend the countertop and it falls to the floor.
- Never alter or interfere with your slab rollers **mechanisms**, there is the risk of damage.
- Ensure you **keep your fingers clear** of the roller entry.
- Treat your slab roller with care and make sure it is cleaned after use.
- **Have fun** using your slab roller safely and creating wonderful pieces of art.



The Slab Roller:

Our slab roller consists of a corrosion resistant roller that is rotated with the aid of a large wheel. This makes the process of clay slab making simple and easy. In addition, the tabletop is moveable (and removable).

Slab Roller Parameters:

- Length - 1020mm,
- Width - 550mm,
- Height - 1100mm

- Thickness of clay slab - 5mm to 60mm

- Diameter of handwheel - 600mm

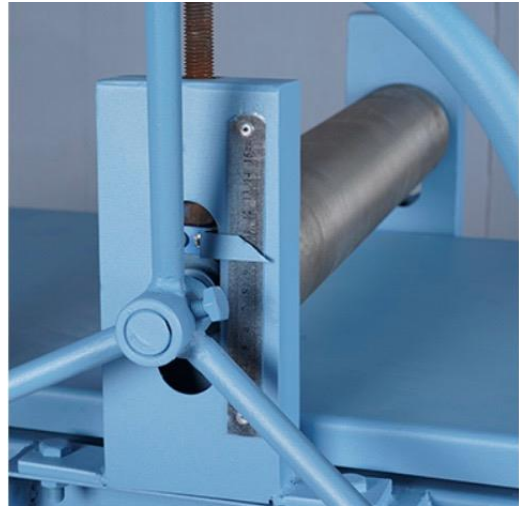

Installation:

1. Attach the four legs of the slab roller using the supplied nuts and bolts, matching the number on the leg and the number on the tabletop.
2. The large handwheel is inserted onto the roller shaft and secured with the locking bolt.
3. Ensure all bolts are tightened before use.

How to use:

1. Spread the clay evenly on one half of the length of canvas.
2. Lift the other half of the canvas over the clay to cover it.
3. The folded end of the canvas should pass through the slab roller 1st to prevent slipping.
4. Use the two roller adjustment wheels to set the roller level. "Zero" thickness is when both wheels are set to 65mm.
Note: The measurement is for roller alignment, not slab thickness!
5. Adjust the wheels in unison to prevent the roller getting stuck.
Note: If one adjustment wheel is raised considerably more than the other, torsion may cause the roller to jam.
6. Use one hand to stabilize the clay inside the linen cloth and the other to turn the large handwheel.
7. Adjust the thickness of the slab by adjusting the two small wheels.
8. Roll the slab back and forth on the mobile tabletop, adjusting the roller position as required.
Note: Don't over adjust when moving it to the far right to avoid detachment of the mobile tabletop.
9. Rotate and flip the clay a few times as it is being rolled to help prevent warping.
10. The tabletop, with the rolled slab on it, can be removed from the slab roller base if desired.
Note: This may be quite heavy!

Precautions:

1. The slab roller should be used in a cool, well ventilated, dry, dust-proof and level place.
2. Pay attention to speed and force when using to avoid damage or deformation of the finished product.
3. The moisture content of the clay should be appropriate during operation. If it is too dry, it may damage the roller mechanism.
4. If it is difficult to turn the hand wheel, you can push it back a little and then push it forward. Repeated rotation in this way will reduce the amount of force required.
5. Pay attention to the thickness of the clay, adjust the thickness of the small handwheel and pay attention to the adjustment distance of the handwheels on both sides, they must be the same.
6. After use, please clean the slab roller with a damp cloth.
7. Lubricate the roller adjustment mechanism and roller wheel under the table top as required.

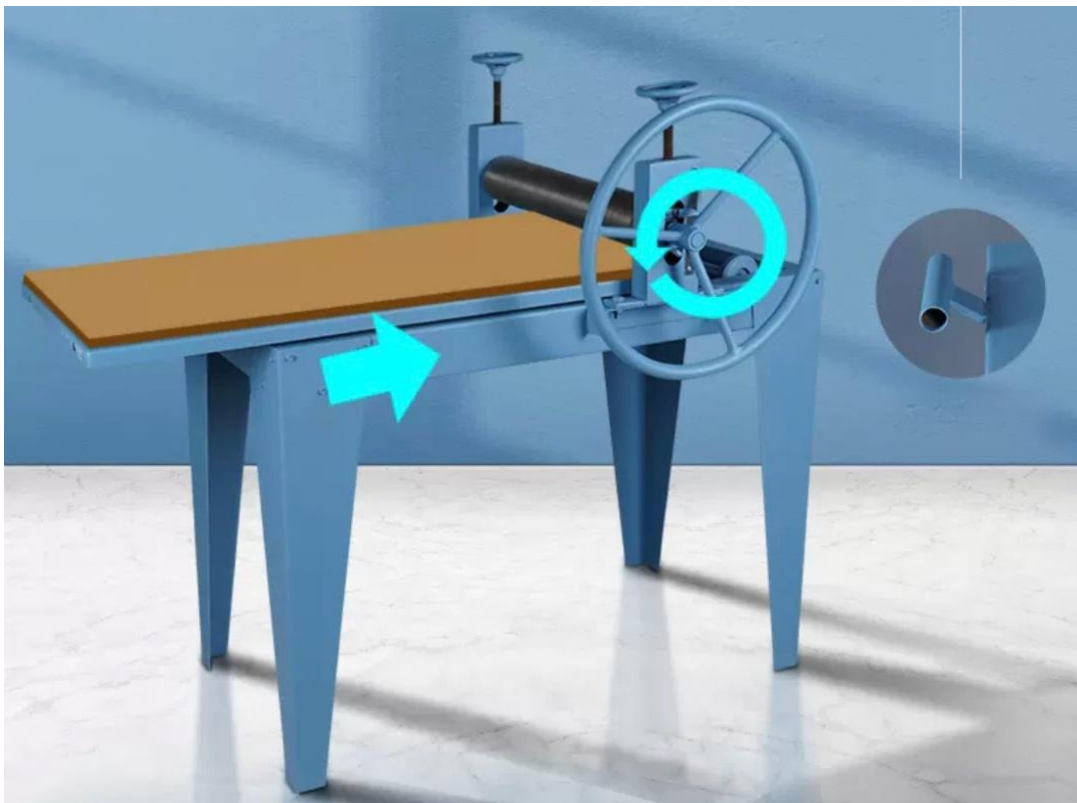

Components:

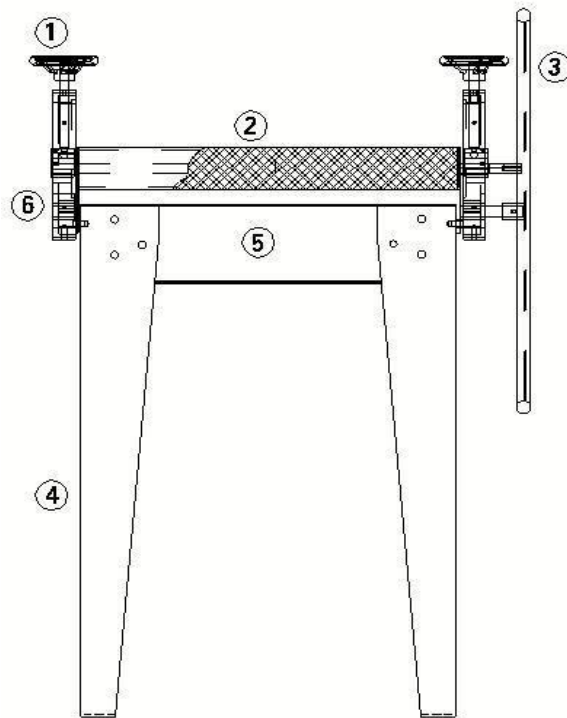

- | | |
|----|--------------------------------|
| 1. | Hand Wheel / Roller adjustment |
| 2. | Roller |
| 3. | Large Hand Wheel |
| 4. | Legs / Stand |
| 5. | Moving Countertop |
| 6. | Roller mechanism / measurement |

Legs / Feet & Large Hand Wheel:

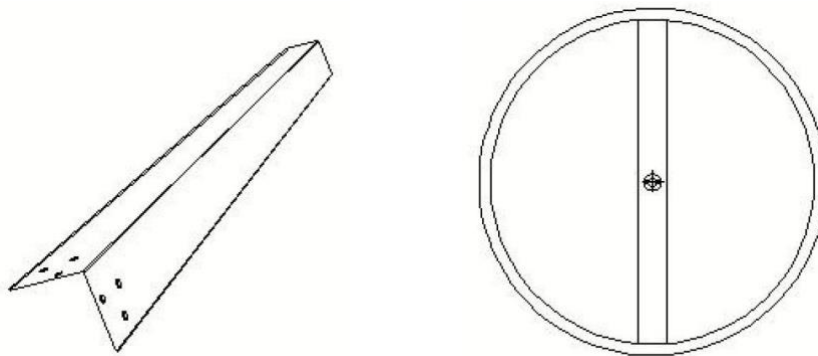

Roller:





FIRED UP KILNS

and pottery supplies

hello@firedupkilns.com.au

20 Helen Street, Heidelberg West, Victoria 3081, Australia

www.firedupkilns.com.au

ABN: 365 984 307 89

Fired Up Kilns works from the lands of the Wurundjeri Woi Wurrung and Bunurong peoples of the Kulin Nation and pay our respects to their Elders past and present. We also acknowledge the Elders, Ancestors, cultures, and heritage of all Aboriginal and Torres Strait Islander Nations.

