



# FIRED UP KILNS

BY:



**pottery**crafts

## Operating Manual

### TOPWORKER KILN RANGE

**P59750, P59760,  
P59770, P59590.**



All PotteryCrafts kilns are CE, ROHS and WEEE compliant



## CONTENTS

Item	Page
1. Damage in Transit.....	2
2. Disposal of Old Electrical & Electronic Equipment.....	2
3. Safety warning.....	3
4. Kiln Supply Voltage.....	3
5. Ultralite loose fill insulation.....	4
5. Kiln Lids.....	5
1. Kiln controller mounting.....	5
2. Positioning the kiln.....	5
3. Ventilation pipe etc.....	6
4. Electrical Requirements.....	6
5. Interlock key switch.....	6
6. Vent hole (centre of lid).....	6
7. Vent chimney.....	6
8. Ventilation ducting (optional).....	6
9. Controller socket.....	7
10. Stainless steel jacket and lid band.....	7
11. Batt / kiln wash.....	7
12. Kiln commissioning / Element Oxidation Firing.....	7
13. Reduction firing.....	8
14. Kiln maintenance / Servicing.....	8
15. Troubleshooting guide.....	9
16. Ventilation for electric kilns .....	10
17. Safe practice with your kiln .....	11
18. Repair instructions.....	12 & 13
19. Pottery tips.....	16-17
20. Pottery firing guide.....	16
21. Biscuit & Glaze firing.....	17
22. Wiring diagrams.....	18–21
23. Own firing schedules record.....	23
24. Contact Details.....	24

## DAMAGE IN TRANSIT

Unpack and inspect kiln as quickly as possible saving all packaging, should any damage be found when unpacking your Potterycrafts kiln please follow these instructions:

Contact the Dealer from whom you purchased the kiln within 24 hours with details of the damage to the kiln.

Do not assemble or attempt to fire the damaged kiln until it has been inspected.

Check that the heating elements are securely in their grooves. If they have come out in transit place them back into their grooves taking care not to over-stretch them or damage the kilns brickwork. Note! If you do not correctly insert the elements into the grooves they will sag and stretch during firing which will reduce their working life.

## DISPOSAL OF OLD ELECTRICAL & ELECTRONIC EQUIPMENT



This symbol on the product or on its packaging indicates that this product (including batteries) shall not be treated as household waste. Instead it shall be handed over to the applicable collection point for the recycling of electrical and electronic equipment. By ensuring this product is disposed of correctly, you will help prevent potential negative consequences for the environment and human health, which could otherwise be caused by inappropriate waste handling of this product. The recycling of materials will help to conserve natural resources.

For more detailed information about recycling of this product, please contact your local government body, your household waste disposal service, or the place where you purchased the product.

## SAFETY WARNINGS



**WARNING! Read all safety warnings and all instructions.**

**Failure to follow the warnings and instructions listed below may result in electric shock or serious injury.**

- It is imperative that the kiln be on a level floor, and allowed to settle for a minimum of 24 hours before it is fired for the first time to reduce the risk of brick cracking.
- Disconnect power supply before attempting any maintenance or moving, servicing must be carried out by a qualified electrician, preferably a kiln engineer.
- Do not allow the mains cable or controller cable to meet the body of the kiln during firing as this will become hot and may cause damage to the cables. Never use the cord to pull the kiln around, a damaged cord increases the risk of electric shock.
- The stainless-steel jacket may discolour from both the heat and gases released by the pieces being fired. Use a cleaning agent suitable for stainless steel or glass to keep the kiln jacket clean.
- Do not open the kiln door/lid until it has cooled to at least 100°C, the door bricks expand and will grip the door jambs, if forced open the bricks can become damaged. Opening the kiln while hot can also cause the elements to bunch or come out of the grooves.
- Do not operate the kiln on a wet surface or in a damp atmosphere or area that can generate heavy condensation. **Water entering a kiln will increase the risk of electric shock!**
- Never attempt to fire higher than the temperature stated on the data plate, please note all our kilns are made from materials designed to withstand heatwork to cone 10, this should not be exceeded.
- Only fire products in the kiln where the properties and melting temperatures are known.
- To avoid burns and fire damage wear protective gloves if the handle needs to be touched during operation.
- The observation Hole Plug and side bung is a hollow ceramic and must be treated with care.
- Keep the area around the kiln free of clutter and never put flammable material against the kiln and preferably not in the kiln room.
- Ensure that the kiln room has adequate ventilation to remove fumes and avoid overheating. See the section on Ventilation.

**Note! When the lid is opened the controller will be powered down and the elements will cease to operate but will still remain hot.**

**Always supervise the first firings of a new kiln and always check at the appropriate time to ensure that the kiln has shut off.**

## KILN SUPPLY VOLTAGE

Pottery crafts kilns sold into the UK and Australia are rated for use on a 230 / 400v electrical supply, overseas kilns are rated in accordance with the respective countries voltage. A kiln must be connected to the correct electrical supply to ensure correct and safe operation. If a kiln is connected to an electrical supply of low voltage this will reduce the top temperature capability of the kiln and reduce the kilns firing speed..

## GENERAL INFORMATION REGARDING YOUR TOPWORKER KILN

Your new kiln is constructed of insulating fire-brick, hand selected to ensure the highest quality. This lightweight brick is an efficient insulator and forms the multi-sided firing chamber which is re-enforced further up by insulation blanket, held together by the compression of the stainless steel jacket.

To facilitate maintenance of the kiln, the bricks are not cemented together. Insulation bricks are fragile and should always be handled with care. After a few firings, hairline cracks may be noticed in the bricks; these are expansion cracks and do not affect the functioning of the kiln.

The kiln jacket is made of high quality stainless steel, secured by hose clamps. During firing, the jacket will become **hot**. However, much of the heat is reflected back into the kiln by the jacket, thus making the kiln more efficient.

PotteryCrafts CERA programmable controller (that must be wall mounted) features extensive protection against possible overfire due to component failure or mains surges however it cannot fully protect against programming errors, as this is input by the user. All PotteryCrafts kilns are fitted with PTRh-Pt thermocouples for accuracy and durability.

Technical specifications:

The information for technical specification varies dependent on the model of the kiln purchased, please see overleaf table which lists further specific information.

This information is also affixed to the kiln, in the case of top loading kilns this can be found on the right hand side of the front electrical box of the kiln, and lists the following:

Type / Model:

Serial Number:

kW rating:

Volts:

Maximum possible firing temperature:

Phase: 1 or 3 (shown as 240v / 415v if applicable)

For electrical regulation information please see below:

ICE electrical Protection class: 1

Enclosure rating of the kiln: IP20

Ambient conditions: 5-55 °C, providing air circulation around the kiln is sufficient.

Model	Capacity	Width*	Depth*	Height*	Weight	Electrical Details		
	Litres	mm	mm	mm		Power Supply Req'd		
	cu/ft	Inches	Inches	Inches		kW	single phase 230v	3 phase 400v
<b>P59750</b>	80 Litres 1300°C 2.8 cu/ft	670	890	880	42	6.6	32	10
<b>P59760</b>	118 litres 1300°C 4.2 cu/ft	670	890	1110	111	8.8	40	15
<b>P59590</b>	190 Litres 1300°C 6.6 cu/ft	850	1090	990	140	12	63	20
<b>P59770</b>	225 Litres 1300°C 8 cu/ft	840	1090	1110	152	13.2	63	20



## ELECTRICAL REQUIREMENTS

Incorrect installation of a kiln can be dangerous; it is legally required that only a kiln engineer or qualified electrician installs and checks the connection in your house / studio. Your kiln will work properly only if it is connected to a power supply with the correct electrical capacity and voltage. Due to incorrect connection being hazardous, a qualified electrician must always be consulted.

### Isolator Label

Each kiln must have a separate isolator switch which must be clearly labelled identifying the kiln that it refers to; i.e. "Kiln 1" or "Kiln 2". The isolator must be positioned to allow clear and easy access to it without touching the kiln. The isolator must comply with current regulations for electrical safety at the time of installation.

### Kiln-On Warning

Some authorities require a red warning light to be fitted outside the kiln room which should be illuminated when the kiln is firing. Alternatively a notice stating that the kiln is in use should be placed on the kiln room door. The position should be immediately visible to emergency services alerting them to presence of high powered electricity in case of emergency.

## MAINS CONNECTION

To prevent wire ends from burning off, check all mains connections are secure. Please ensure that grommets / glands are used when passing mains cables through holes in the metal kiln casing when making an electrical connection. Only kilns operating from 13 amp are supplied with a cable and plug, all others are supplied kiln body only and must be connected by a certified electrician.

**Note!** When working on the kiln always turn the kiln power and the isolator switch to the OFF position. Mains connections to the kiln must be made in a workman-like manner and correct tightened failure to do so can result in the terminal burning out.

### WORK AREA SAFETY

Keep area clean and well lit.

Cluttered or dark areas invite accidents

Do not operate kilns in explosive atmospheres, such as in the presence of flammable liquids or gases.

Keep children, pets and bystanders away from the kiln whilst in use.

### PERSONAL SAFETY

Stay alert, watch what you are doing and use common sense when using a kiln.

Do not use a kiln whilst tired or under the influence of drugs, alcohol or medication.

A moment of in-attention whilst operating a kiln may result in serious personal injury.

Use personal protective equipment recommended when stated clearly in this instruction manual, Do not overreach when lifting or placing kiln furniture or ware during loading or unloading of the kiln.

Keep proper footing and balance at all times whilst loading / unloading a kiln.

## What is an electric pottery kiln?

Kilns are chambers designed to contain heat so that temperatures can be achieved sufficient for clay to be converted to ceramic. The source of heat in electric kilns is the heating elements, wire coils that produce heat as a result of resistance to the flow of electricity. They are similar to the elements in an electric fireplace within your home. The kiln chamber is constructed from insulation materials that contain the heat reflecting it back into the kiln. A kiln is in terms of components and build, an enclosed electric fire place.

### Potterycrafts Kilns have the following safety features.

- Over-temperature safety cut-off devices with all kilns.
- Anti-spike electrical surge protection with all controllers.
- Power On light - red warning light illuminated when the kiln is powered up.
- Element On Lights - white lights that illuminate when power supplied to elements.
- Fuses - 3amp controller fuses fitted behind front panel of front loaders kilns
- Interlock - switches off power to elements before opening the door, essential safety equipment. Kiln won't work if not in place.

### Safe Practice

- Interlocks and Lid Safety switches prevent power from reaching elements when the door is opened, these should never be over-ridden or tampered with.
- Door opening - opening when hot, i.e. in excess of 100°C may cause brickwork to crack. Front loaders with taper fit doors are held fast by expansion when hot, if forced open serious damage can be done to the brickwork.
- Ventilation - essential to have moving air for heat and fumes, see page 9.
- Supervision of firing – always supervise kiln firings. It is essential to supervise the first few firings of any new kiln.
- All current Potterycrafts kilns are fitted with over-temperature cut-off devices, which shut down the kiln in the event of a component failure causing the kiln to reach 20°C hotter than the target temperature.
- All current Potterycrafts controllers are fitted with anti-spike devices to help prevent damage caused by electrical surges.
- Despite the safety features, damage can still occur through poor programming, for example, earthenware fired to a stoneware temperature will melt and could destroy kiln bricks and elements—never fire clay or glazes where you do not know of their maturing temperature.
- Electrical Work – must only be carried out by a qualified electrician, as per UK law.

# KILN INSTALLATION & POSITIONING

## Installation

When the kiln is being installed, make sure that the room/space will house the kiln is dry, and water proof. Temperatures in this space should ideally be between +5°C / +50°C. The surface (floor or specialist stand) where the kiln is to be installed must be level to enable the kiln to stand upright. It is important that the minimum safety spacing as written below is adhered too at all times during the use of the kiln, it is separated for small, medium and large size kilns as different advice applies based on size and build type.

### Top loading kilns:

The minimum safety gap of 0.5m around the kiln at all approaches during firing. Potterycrafts top loading kilns are fitted with castors for ease of delivery and movement for servicing. Excessive movement of the kiln will cause the insulation bricks used in the chamber to crack, care must be taken when re-positioning the kiln. One or more of the castors will be lockable and the brake should be applied when firing the kiln.

It is imperative that the kiln be on a level floor, and allowed to settle for a minimum of 24 hours before it is fired for the first time to reduce the risk of brick cracking.

### Ceilings:

Allow a minimum of 1.5 m between the top of the kiln (including ventilation hood if installed) and any ceiling whether false or otherwise; if the ceiling is made from combustible material this must be protected with heat resistant board fixed with a minimum 10cm gap between board and ceiling. Any materials used must meet the fire safety A DIN 4102-1 guidelines to be used within the room where the kiln is to be installed.

### Flooring:

The flooring must be suitable to take the weight of the kiln plus any accessories such as stand or furniture. All potterycrafts electric kilns must be placed on a non-combustible surface (fire safety class A DIN 4102-1) example: Concrete, tiles, aluminium or steel.

### General Notes:

Any flammable materials such as packing materials or curtains / plastics must be kept away from the kiln, never leave anything on top of the kiln even when not in use. The kilns power / controller cable must not be allowed to touch the kiln case.

Whilst kilns do not give off any fumes and much of today's pottery products are non toxic some ceramic products can release gasses / fumes. Therefore it may be necessary to extract these gasses / fumes. If the kiln cannot be ventilated naturally then mechanical extraction maybe required, please refer to the ventilation section in this manual.

### Kiln Jackets are Hot

The surface of kilns can become quite hot and after long firings to high temperatures could reach up to 150°C. Although this is well below combustible temperatures of materials like paper it is still hot enough to burn if in contact for more than a second or so; it is therefore important to ensure that children, pets and vulnerable people are supervised while in the vicinity of the kiln.



## **QUICK REFERENCE GUIDE FOR VENTILATION.**

Poor ventilation of kiln rooms can cause problems of excess heat, fumes and can even cause the kiln to shut down. These problems are addressed at length in our notes: "Ventilation for Your Electric Kilns" if you would like a copy please see our support section of our website; in the meantime here are the key points.

### **Small kilns (up to 6 kW rating)**

In a medium sized room, often the option of using a window for ventilation is found to be sufficient. If in doubt we advise that an extraction fan is fitted, and a suitable source of replacement air is made available from outside the building.

### **Medium Size Kilns from (6 to 15 kW rating)**

In a medium to large room, an extraction fan and air bricks are recommended for the room. No guidelines are laid down for the ventilation of rooms containing electric kilns, however, as a general guide on air changes; around 20 - 40 air changes / hour, should suffice (refer to ventilation recommendations for kitchens within schools). If the room is small you may require more air changes to keep the temperature at a comfortable level.

A canopy may need to be introduced and fitted directly above the kiln and connected to the extraction system. In conjunction with a source of air from outside the building, this arrangement provides a method of removing excess heat directly from the area around the kiln whilst providing the most effective method of removing any fumes. PotteryCrafts Ltd would recommend consulting a ventilation company for their advice, one that deals with high temperature solutions for the catering or industrial purposes.

### **Constant air movement**

An open window is probably OK for small kilns. A 200mm domestic extractor fan is usually sufficient for larger sizes of kilns but even a massive industrial fan won't work *if there isn't any replacement air coming from outside - not just the next room - outside!*

### **Fumes and Excess Heat**

Electricity does not produce fumes but clay/glaze and colour can be a bit smelly during the firing. The danger is unlikely to be greater than walking down a busy high street, but don't work in the room when the kiln is firing. Excess heat can cause the kiln controller to shut down as many are fitted with internal thermometers.

### **Heat/Smoke Detectors and Sprinkler Systems**

Kilns cannot catch fire - *how could there be anything in them that burns they are designed specifically to contain heat.* Ensure that anything combustible is kept away from the kiln especially the flue and spy holes. Site heat and smoke detectors immediately *outside* the kiln room, do not have water sprinklers within range of the kiln.

### **Safety Advice for Electric Kiln Users**

The function of an electric kiln is to contain heat; the external skin of the kiln is therefore kept to temperatures below point of ignition of substances such as paper. The only points where there is a direct heat source are the flue and spy/ventilation holes, these are protected by bungs. Electric kilns are therefore no more of a fire hazard than a domestic oven and are safe to operate providing common sense working practices and manufacturer's instructions are followed. We hope that the following notes will allay any worries, if you have any concerns please do not hesitate to contact our technical staff.

## UNPACKING YOUR NEW KILN.

When you come to unpack your new kiln there will be various bubble wrapped packages within the chamber of the kiln.

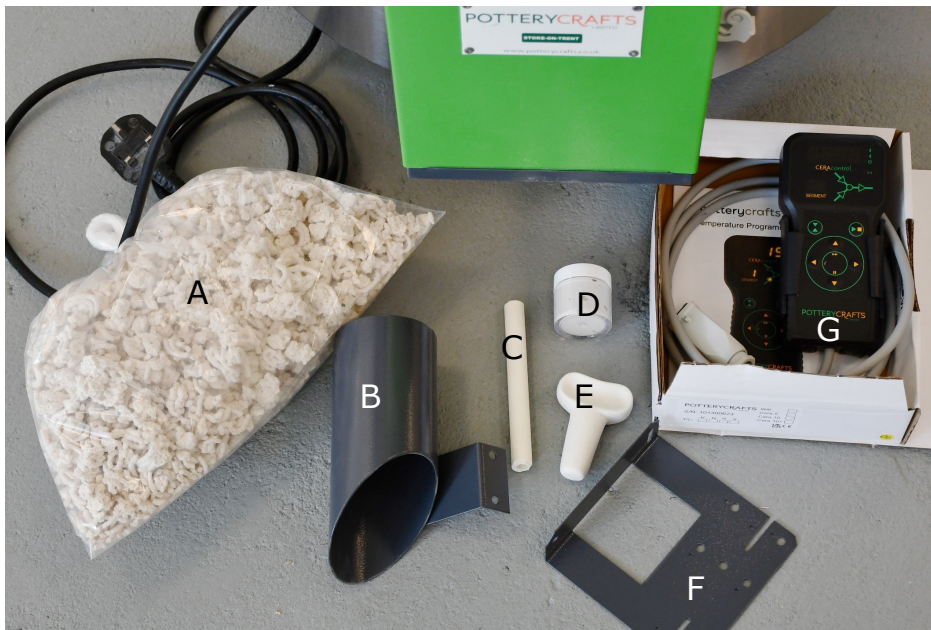

- A—Ultralite Loosefill insulation—excess if required—to be placed in the base of the kiln.
- B—metal chimney—affixed over the porcelain vent tube.
- C— vent tube for chimney.
- D— kiln brick cement to affix ventilation tube in chimney.
- E—porcelain top bung.
- F—controller bracket— to be affixed to the side of the kiln.
- G— controller in box with manual.

## FURNITURE SET



The furniture will be placed on the pallet alongside your kiln.

In this furniture kit you should receive:

500g batt wash

A selection of batts or shelves, a selection of props in various sizes.

For how to place the furniture set within your kiln please refer to page— 12.

Note! Potterycrafts recommend batt wash be applied onto one side of each shelf and fired on before using the kiln for firing any work.

## VENTILATION PIPE ETC

The kiln room should be well ventilated to allow a continual change of air. A domestic extractor fan can assist areas that have no air flow. Note! An extractor fan will only work efficiently where there is an air inlet to allow for fresh air to be brought back into the room. Extractor fans should not be placed immediately above a kiln.

## VENT AND CHIMNEY FIXING INSTRUCTIONS

When your kiln arrives to you the chimney, controller bracket and the venting pipe will be wrapped safely inside the kiln chamber, if you un wrap this and then follow the instructions below to attach your new kiln!

Items supplied:

- 1 x Chimney .
- 1 x Porcelain Tube 137mm Long Approx.
- 1 x small container of specialist refractory cement.

not supplied but required:  
PPE—gloves, safety goggles, mask if required.  
1 X Philips head screwdriver  
damp rag to wipe excess.

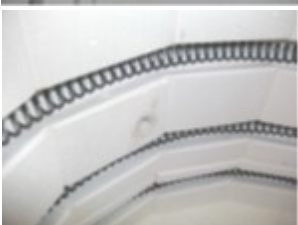

- The porcelain tube, shown in the picture to the left, provides a permanently open vent to the kiln chamber, this allows moisture and fumes to exit the chamber keeping the atmosphere clean and preventing contamination. Remove the Porcelain tube from its packaging of bubble wrap.
- Apply the kiln cement to one end of the tube as shown in the picture to the right, this can be done as shown or by applying a small amount with a damp, gloved finger, with the container from the cement and placing it round the tube. The cement should cover the last 25—30mm of the tube.
- Open the lid of the kiln and insert the tube into the 15mm diameter pre-drilled hole in the kiln brickwork, as shown in the picture to the left. The end of the tube without the cement should be inserted first, then the tube should be push slowly in until it is flush with the kilns sidewalls. If the hole is too tight gently work the tube through, the soft brick will wear as you push it through.
- Once in position as shown in the picture to the right, wipe away any excess cement to ensure a good even coating around the tube (check that there are no gaps between the tube and outer brick-work). Once attached please allow 12-24 hours for the cement to set.
- From the outside of the kiln the tube will look as the picture to the left. Now using the Philips screwdriver remove the two chimney fixing pins, these are located just above the porcelain tube to the left.
- The chimney serves to protect the vent tube and can also be used to vent the kiln by attaching flexible metal ducting which can carry fumes direct to outside. Screw the chimney in position as shown in the picture to the right.

## KILN LIDS

1. The latest Potterycrafts brick lids now incorporate a sliding hinge. This fitting is deliberately loose to allow free expansion movement of the lid during the firing process. During the firing process a glow will be visible between the lid and kiln body. It should be noted that this glow (light) does not equate to heat loss. As the bricks expanded during the firing a small gap can open between the lid and kiln body but due to the nature of the insulation brick this reflects the heat back into the kiln. Tests at Potterycrafts have demonstrated that heat loss is minimal and does not affect the kilns performance.

### 2. Expansion & Contraction

Because of the extreme variation of temperature occurring during the firing process hairline cracks may occur in the lining of the kiln. These are quite normal and will not affect the normal operation of the kiln.



### INTERLOCK KEY SWITCH

This kiln is fitted with a captive key interlock attached to the lid. The kiln cannot be fired unless the lid is closed and the key is inserted into the lock and turned 90° clockwise. The switch is only for safety and should not be used as a mains isolating switch. An interlock is required by Health & Safety, under no circumstances should it be bypassed.

### VENT HOLE (centre of lid)

This allows moisture to escape during the firing process, this should be left out until the kiln has reached between 500°C – 600°C or glows a cherry red colour inside, then the plug should be inserted for the remainder of the firing process.

### VENT CHIMNEY (Optional)

The Potterycrafts Mercury, Aurora & Comet kilns are fitted with a vent hole at the top left-hand side of the kiln in addition to the hole in the centre of the lid, this allows the escape of moisture and gases from the chamber during firing. The vent pipe is protected by a 80mm diameter chimney. If required a flexible ducting can be fitted to the chimney to exhaust gasses to atmosphere, and this must be of a high temperature rating, this is up to the user to arrange if required.



*Note! When a vent chimney is not fitted a kiln bung must be used during the firing.*

### VENTILATION DUCTING (Optional)

Zinc coated or stainless steel 80mm diameter ducting can be used as an exhaust pipe which is attached to the kilns vent chimney. The ducting needs to be positioned so that it is always rising. For long distances an inline fan may be required to assist in drawing the gases out to atmosphere.

Note! whilst the gases coming out of the kiln via the vent chimney are heavily diluted with cool air the ducting still may be hot.

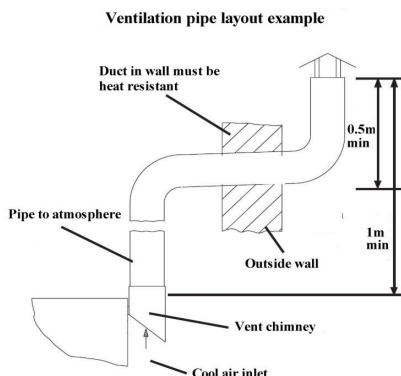



## THERMOCOUPLE

The thermocouple works in conjunction with the controller to accurately measure the temperature within the firing chamber. All Potterycrafts kilns are fitted with type R thermocouples for accuracy and durability.

The thermocouple is located in the wall of the kiln approximately 1/3 from the top of the chamber, in larger models its around the middle of the wall in the chamber, which protrudes slightly out into the chamber for more accurate temperature readings.

*Note! Please take care when loading the kiln not too knock or break the thermocouple—for more information see kiln loading.*

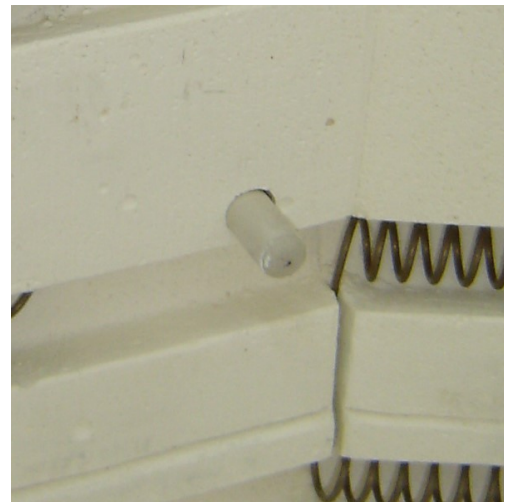

## ULTRALITE LOOSE FILL INSULATION

The base insulation in these kilns is a granular loose fill insulation. Produced from waste kiln brick dust the granular insulation is used in our top loading kilns instead of the usual brick base. We supply a small extra quantity in a bag which can be used to top up the quantity of loose fill in the base should it be needed, if glaze or clay ever contaminates this Loosefill, remove the damaged amount and replace it with the additional quantity.

*(Please ensure that the loose fill insulation does not get into the element grooves, or raise*



## KILN CONTROLLER MOUNTING

The Mercury, Aurora & Comet kilns are now supplied with an additional bracket that can enable your controller to be mounted on the right-hand side of your kiln. If you wish to wall mount the controller instead this should be done on a flat surface away from the heat of the kiln. Please follow the controller instruction manual when doing this.



## CONTROLLER SOCKET

Where kilns are supplied for use with a controller a Harting (Han7) controller socket will be fitted to the right-hand side of the front control box of the kiln. The HAN7 socket is slotted to allow the controller plug to fit only in the correct way.

## STAINLESS STEEL JACKET & LID BAND

The stainless steel jacket and lid band on top loading kilns may discolour from both fumes and heat from the ware being fired. Use stainless steel cleaner or glass polish to keep the steel clean. After every five firings it may be necessary to tighten the jacket and lid band clamps as some shrinkage of the bricks may occur. If this is not done the movement between the steel jacket and brick can result in cracking or possible broken sidewall brickwork..

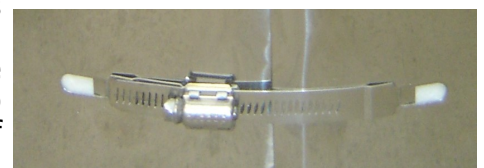

## BATT / KILN WASH

Mix the Batt Wash with water to a single cream consistency. (50/50 ratio usually works well, add the water a small amount at a time until the correct consistency is achieved.

Apply with a wide brush to the side of any batt being used. 2-3 coats alternating the direction of application will be sufficient, allowing each coat to dry before applying the next to avoid peeling. This will prevent glaze from sticking to the shelves (batt wash should not be applied to the kiln walls or underside of the shelves or underside of lid). Let batt wash dry thoroughly before loading the kiln.

## FURNITURE STACKING PLACEMENT

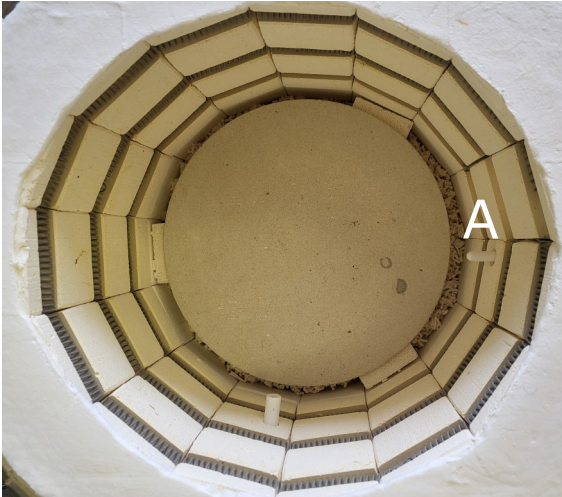

The kiln is provided with furniture applicable to the size of the firing chamber, we recommend the furniture is placed first on the base props bricks protruding through the Loosefill insulation, then 3 props are positioned equal distance apart across the kiln.

Once you have applied your batt wash to one side of each kiln shelf you can then place them in the kiln as example below.

Please note photos are for guide purposes only, if you have any questions please contact the distributor of your kiln.

When loading shelves into the kiln please be careful not to damage the thermocouple, (A) also do not place shelves / batts at the same level as the thermocouple as this can give a false temperature reading, be careful to not place work to near it as this can also affect the temperature reading gained during the firing cycle.

*NOTE!: Please allow a minimum distance of 2.5cm (1 inch) between the ware/furniture and thermocouple as there is a risk of over-firing any item close to the element.*

*Note! New kiln furniture (e.g. plate sitters and supports) should be dried out by heating them once (as described above), to remove any excess moisture, burn out any binders that may be present, and other residue left over from the manufacturing process.*



## KILN COMMISSIONING / ELEMENT OXIDATION FIRING

Whilst the majority of your top loader kiln is dry built it is advisable to dry / test fire the kiln first, this will also help to form a clean oxide layer across the heating elements to maintain a good element working life. (Note! heating elements are coated in a protective film this will burn off during this first firing and can cause an unpleasant smell and some smoke may also be given off, as the protective coating is removed in this firing).

Any vent plugs should be left out for this 1<sup>st</sup> firing.

Close the lid and engage the kilns interlock.

This first firing should contain only the furniture set positioned in the kiln as if it was to be loaded with ware, to mimic a full kiln load and allow the temperature to be even throughout the firing chamber, if no furniture was present it can cause uneven temperature increases and can affect the element positioning.

Segment 1 ramp rate	Seg 1 target temp	Soak / dwell time	Seg 2 ramp rate	Seg 2 temp	Seg 2 soak / dwell	Seg 3 ramp rate
50c	100c	00.45 mins	150c	1100	02.00 hr soak	END

This is pre-set in your controller to PROGRAMME 1. programs in your controller for your fired up kiln are all pre-set—please see interleaf included.

Once this has completed allow the kiln to cool down naturally.

To enter the program shown above please read the instructions for the controller.

*Note: New kiln furniture (e.g. plate sitters and supports) should be dried out by heating them once (as described above), to remove any excess moisture, burn out any binders that may be present, and other residue left over from the manufacturing process.*



## **REDUCTION FIRING**

**This kiln is NOT suitable for reduction firing.**

**Any such firing will void the warranty on your kiln.**

## **KILN MAINTENANCE / SERVICING**

Regular cleaning of the inside to remove debris from both the chamber and element grooves will help to increase the working life of your kiln.

**Attention:** Do not knock the heating elements when cleaning as this can break them.

**Note!** As the heating elements age they will lose efficiency resulting in extended firing times and a lower top temperature capability, when this happens the elements will need to be renewed.

**It is advised that the kiln be serviced annually by a qualified electrician.**

We would advise that your kiln be serviced / inspected annually to ensure years of good service.

Below is a list of items checked in the annual service.

- Kiln location inspection (no flammable items etc near kiln).
- Exterior examination for signs of corrosion or other external hazards.
- Interior check of brick lining.
- Element visual inspection.

Kiln control box including:

- (damaged cables, brittle, burnt cables / damaged ends terminations tight etc).
- Safety switch testing.
- Element load and voltage test.
- Controller function test.

Upon inspection a certificate can be issued for your Health & Safety file.

**Only a qualified electrician may carry out work on a kiln's electrical system.**



## TROUBLESHOOTING GUIDE.

<b>Error</b>	<b>Cause</b>	<b>Error Elimination / Cure</b>
Controller does not switch on.	No voltage or controller is defective. Lid not closed.	Check / replace mains fuse. Check / replace fuse in controller. Check plug fuse. Interlock not switched on.
Controller shows error	See controller instructions.	
Kiln does not heat when the program has been started Or Very slow heating of the kiln Or Top temperature is not reached.	Programming error.  Heating element broken Contactor pole failure Safety switch.  Heating element broken Low voltage.	Check program entered - See controller instructions.  Replace heating element. Replace contactor. Check / replace switch as required.  Replace heating elements. Check voltage & contact Pottery crafts.
Red glow between brick lid & body.	This is normal with high temperature kilns.	If the gap gets larger, consult our technical department.
Fuse melts immediately after kiln is switched on.	Short circuit - Overloaded circuit.	Have the wiring checked.  Disconnect any other appliances from the circuit.
New element has burnt out.	Glaze on element. Batt wash on element. Debris from old element.	New element required.  New element required. Clean groove before fitting new element.
New element burnt out in control box.	Connection not tight enough.	Replace element, tighten pins.
Kiln overfires.	Jammed contactor or relay.	Replace contactor or relay.
Ware keeps breaking.	Heating / cooling ramp too fast.	Slow down heating / cooling speed of kiln.
Kiln gives off nasty odour.	The ware burning off impurities New elements burning off coating.	This will clear.

## REPAIR INSTRUCTIONS

Only a qualified electrician may carry out work on the electrical system!

Ordering spare parts

Before contacting your distributor of your kiln please have with you the following information from the kilns data plate:

Model

kW loading

Serial Number

Year of manufacturer

We can be contacted either by phone or Email:

Fired up kilns Australia.  
Factory 39,  
10 Cawley Road,  
Yarraville Victoria 3013,  
Australia

Tel:

Within Australia: [0473 748 870](tel:0473748870)

Outside Australia: [+61 473 748 870](tel:+61473748870)

[enquiries@firedupkilns.com.au](mailto:enquiries@firedupkilns.com.au)

### Safety advice

The kiln contains ceramic fibre blanket as a backup material. This material is an irritant and should not be handled unless working in a well ventilated area with suitable protective personnel equipment such as a protective suit, gloves and breathing mask.

### Removal of old element

Disconnect kiln from the mains / remove plug.

Using the Phillips screwdriver remove the front panel from the control box.

Using a flat bladed screwdriver or nut whirler loosen and remove the pins on top of the porcelain block / brass connector then slide off end of element tail. (Only remove one element at a time to reduce the risk of getting the electrical connection wires mixed up).

Remove any element pins / staples that are securing the elements inside the kilns chamber.

Take out the old heating element.

### Fitting new element

Clean any debris out of the old element groove. If there is any signs of a burnout or glaze marks this should be dug out of the brick to avoid possible premature failure of the new element. (If this makes a deep hole in the brick then this should be packed out with ceramic fibre)

From inside the chamber insert the element tail through the hole in the sidewall and feed the pre stretched element around the grooves within the kiln.

Slide the "Bell porcelain tubes" over the outside of the element tail going into the front box. Then trim off tail excess and attach the porcelain / brass connector. Once this is done then the electrical cables should be attached into the opposite end of the connector.

## Repairing the insulation brick

The low thermal mass insulation bricks used in your kiln are riddled with small holes these give them their insulation characteristics. We would only suggest replacing a section or a complete brick should the damage be serious.

- Disconnect kiln from the mains / remove plug.
- Cut out a rectangle around the damaged area of brick.
- Remove any dust residue with a vacuum cleaner.
- Fit in a new piece of brick using a refractory cement to bond it, once this has set use a rubbing stone or abrasive to shape the brick as required.
- Remove again any dust residue with a vacuum cleaner.
- If a complete brick need to be changed remove the lid and then using the jacket tensioners release the pressure on the brick sufficiently to allow the damaged one to be removed.

*(Please be very careful when doing this as you may break the elements in the kiln).*

## Replacing A Thermocouple

Disconnect kiln from the mains / remove plug.  
Using the Phillips screwdriver remove the front panel from the control box.  
Remove the thermocouple locating pin.  
Remove the white and orange ends of the compensating cable from the porcelain block on the thermocouple.  
Remove the damaged thermocouple and replace with new one.  
Connect compensating cable to thermocouple porcelain block (orange = +, white = -).  
Using a screwdriver secure the thermocouple with the locating pin.  
Re-attach the front panel to the control box.

**Note!** *always replace the thermocouple with an identical unit, if your kiln is fitted with the wrong type of thermocouple this could result in an over-fire. Which is not protected under your warranty.*

## Replacing A Contactor

- Disconnect kiln from the mains / remove plug.
- Using the Phillips screwdriver remove the front panel from the control box.
- Using a screwdriver remove the contactor fixing pins.
- Swap over the terminals one at a time from the old contactor to the new making sure the contacts are secure. Please ensure that only load carrying terminals are used and not the auxiliary terminals and that the suppressors are also fitted correctly.
- Using a screwdriver secured the contactor.
- Re-attach the front panel to the control box.

**IF YOU ARE UNSURE PLEASE CONTACT OUR TEAM BEFORE PROCEEDING.**

## GENERAL POTTERY TIPS

The following information is a guide only:-

- Allow any clay to dry slowly – not in a heating room or in the sun.
- Avoid drafts – drafts can lead to uneven drying and result in cracks.
- Wrap either foil or a little paper around protruding parts (e.g. handles, spouts), to prevent them from drying out faster than the rest of the piece.
- Cracks normally occur around joints.
- Leave the ware to dry for at least 1-2 weeks – if the weather is damp this period may need to be extended.
- Clay shrinks during the drying out process (this is because of water loss), because of this please place ware on dry padding to prevent sticking.
- The ware may need to be turned several times, as it dries faster at the top of the piece.
- Hold dried products carefully with both hands as there are very fragile in their green-ware state.

## FIRING GUIDE

The firing process is divided into biscuit or glaze firings. We have given a more detailed information on the various firing types on the following pages.

Now place the upright props into the kiln above the floor spacers then place the ware / product onto the shelf in the kiln distributing it as evenly as possible.

*NOTE!: Please allow a minimum distance of 2.5cm (1 inch) between the ware/furniture and thermocouple as there is a risk of over-firing any item close to the element.*

Now the second shelf can be added.

When loading shelves into the kiln please be careful not to damage the thermocouple, also do not place shelves / batts at the same level as the thermocouple as this can give a false temperature reading.

## Firing Tips & Recommendations

### Biscuit Firing

Once the ware has fully dried, it then requires a first firing. This firing is generally in the region of 900 – 1000°C this firing causes a physical chemical change in the clay that lock together the molecules resulting in the clay becoming hard and insoluble (like a brick) the makes the ware hard enough to touched and worked with.

Care must be taken not to fire the kiln too quickly because the water is being driven off as steam it must have sufficient time to escape, if this is not done then the ware may explode. Because of this we would suggest for a standard thickness of ware (around 6mm) the kiln should be set to heat at around 80 – 100°C / hour to 600°C. Once this temperature has passed and the clay has passed through its critical stage when it no longer becomes soluble in water then the kiln can be speeded up until top temperature has been reached. The cooling down period for a kiln typically takes the same time as the heating cycle.

### Glaze Firing

The glaze firing is usually the hottest firing, this is not always the case in some clays and industrial practices vary between potters.

The temperatures for these firing range as follows:-

Earthenware Between 1040 – 1080°C

Stoneware 1200°C+ (This is mostly for white clay and is a minimum temperature) The glaze must be compatible with the stoneware body being used.

*It is advisable before carrying out any glaze firings that the shelves are coated with batt wash to reduce the risk of glaze sticking to the shelves. This coating should be renewed from time to time, please see section on batt washing shelves (page 7).*

*Any unwanted drops of glaze on the piece can be removed either by using a stilt stone or rotary grinder and then if required it can be touched up and re-fired.*

Biscuit items can be stacked providing they are not too heavy or they don't interfere with each others contraction during the firing process. Flat items or tiles should be placed directly on the kiln shelves / batts to reduce the risk of deformation / warping.

Please be patient, don't open the kiln too early or force cool the kiln by partly opening a door or propping a lid open as the can cause the ware to crack or the elements to become dislodged from there grooves. The kiln can be opened slightly once it has cooled below 100°C.

DRG No PC 107-2010

ALL INTERNAL WIRING TO BE IN SIAF CABLE

UK & OVERSEAS KILNS FITTED WITH 'R' TYPE THERMOCOUPLES  
 CERADEL KILNS FITTED WITH 'S' TYPE THERMOCOUPLES &  
 2.5 METRE 6mm<sup>2</sup> 3 CORE MAINS CABLE WITH 3 PIN 32 AMP PLUG

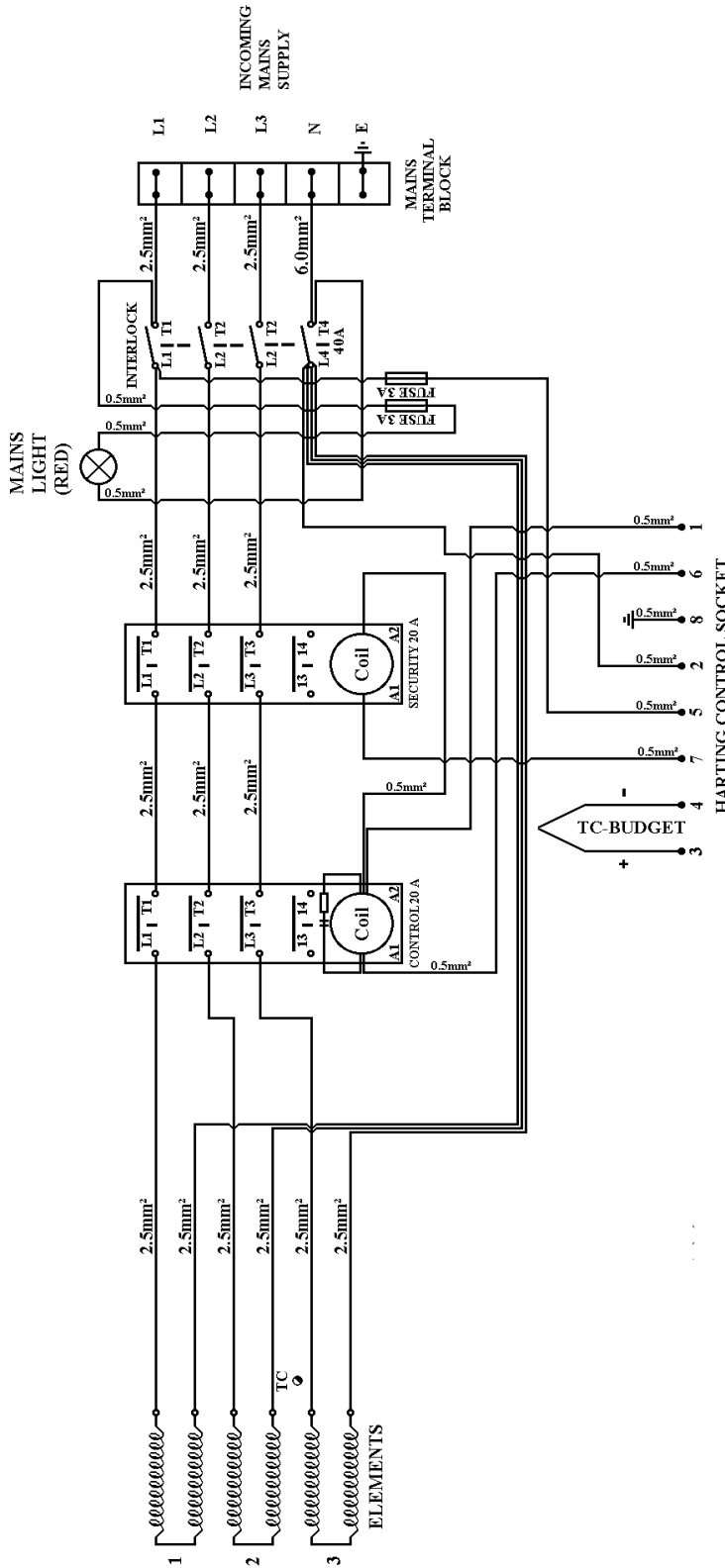

THE MAINS TERMINALS FOR THIS KILN ARE  
 LOCATED INSIDE THE KILNS FRONT BOX  
 APPROX 2/3 UP FROM THE BOTTOM.  
 DO NOT CONNECT MAINS DIRECTLY  
 TO THE CONTROLLER!

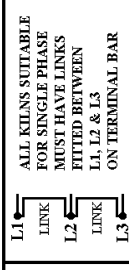
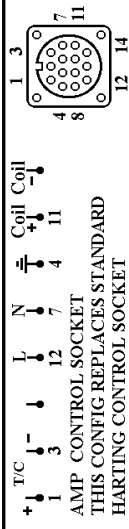

ALL KILNS SUITABLE  
 FOR SINGLE PHASE  
 MUST HAVE LINKS  
 FITTED BETWEEN  
 L1, L2 & L3  
 ON TERMINAL BAR

TITLE  
 MODEL TOPWORKER P59750 6.558kW on 230v, (F) 6.0kW on 220v 1300°C  
 WIRING DIAGRAM 3+N+E

POTTERY CRAFTS LTD ©  
 CAMPBELL ROAD  
 STROKE-ON-TRENT  
 ST4 4ET  
 TEL 01782 745000  
 FAX 01782 746000  
 e-mail: enquiries@potterycrafts.co.uk

HARTING CONTROL SOCKET  
 NOTE! ALL METALLIC SURFACES ARE BONDED

SUPPLY REQUIREMENTS		DATE
VOLTS	220	THREE
KW	6.0	32A
	230	32A
	240	32A
DRAWN BY	J CROSS	M WINT
APPROVED		
DRG No	PC 107-2010	REV

DRG No PC 108-2010

ALL INTERNAL WIRING TO BE IN SIAF CABLE

UK & OVERSEAS KILNS FITTED WITH 'R' TYPE THERMOCOUPLES  
 CERADEL KILNS FITTED WITH 'S' TYPE THERMOCOUPLES

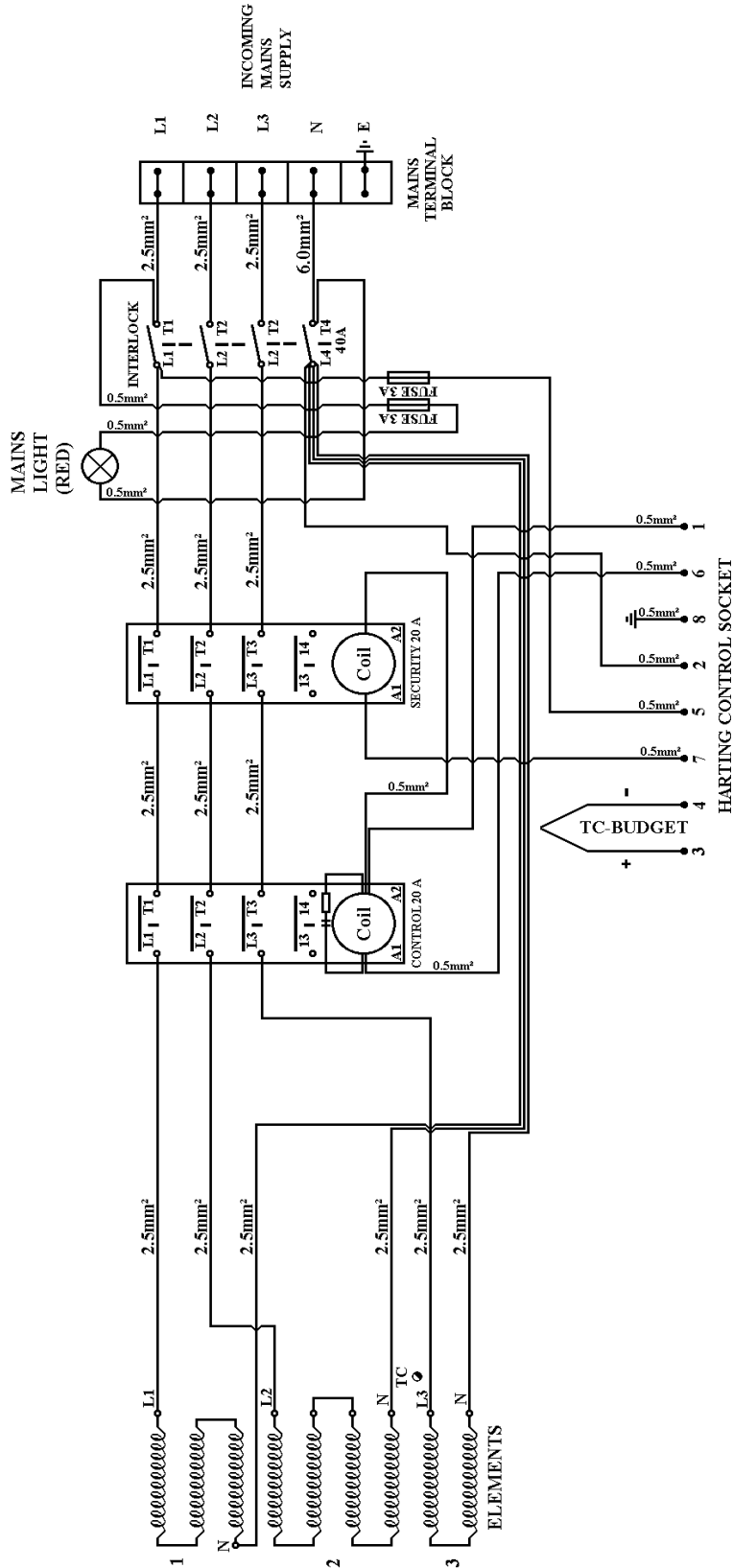

THE MAINS TERMINALS FOR THIS KILN ARE  
 LOCATED INSIDE THE KILNS FRONT BOX  
 APPROX 2/3 UP FROM THE BOTTOM.  
 DO NOT CONNECT MAINS DIRECTLY  
 TO THE CONTROLLER!

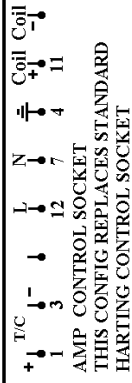

ALL KILNS SUITABLE  
 FOR SINGLE PHASE  
 MUST HAVE LINKS  
 FITTED BETWEEN  
 L1, L2 & L3  
 ON TERMINAL BAR

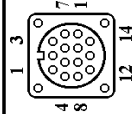

TITLE  
 TOPWORKER P59760 8.75kW on 230v, (F) 8.0kW on 220v 1300°C  
 MODEL CERADEL V114n 7.0kW on 220v 1300°C WIRING DIAGRAM 3+N+E

SUPPLY REQUIREMENTS		
VOLTS	220	THREE
KW	7.0	15A
SINGLE	30A	15A
APPROVED	MWINT	DATE
DRAWN BY	J CROSS	28-05-2010
DRG No	PC 108-2010	REV

HARTING CONTROL SOCKET  
 NOTE: ALL METALLIC SURFACES ARE BONDED

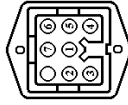

POTTERY CRAFTS LTD  
 CAMPBELL ROAD  
 STROKE-ON-TRENT  
 ST4 4ET  
 TEL 01782 745000  
 FAX 01782 746000  
 e-mail: enquiries@potterycrafts.co.uk

DRG No PC 109-2010

ALL INTERNAL WIRING TO BE IN SIAF CABLE

UK & OVERSEAS KILNS FITTED WITH 'R' TYPE THERMOCOUPLES  
 CERADEL KILNS FITTED WITH 'S' TYPE THERMOCOUPLES

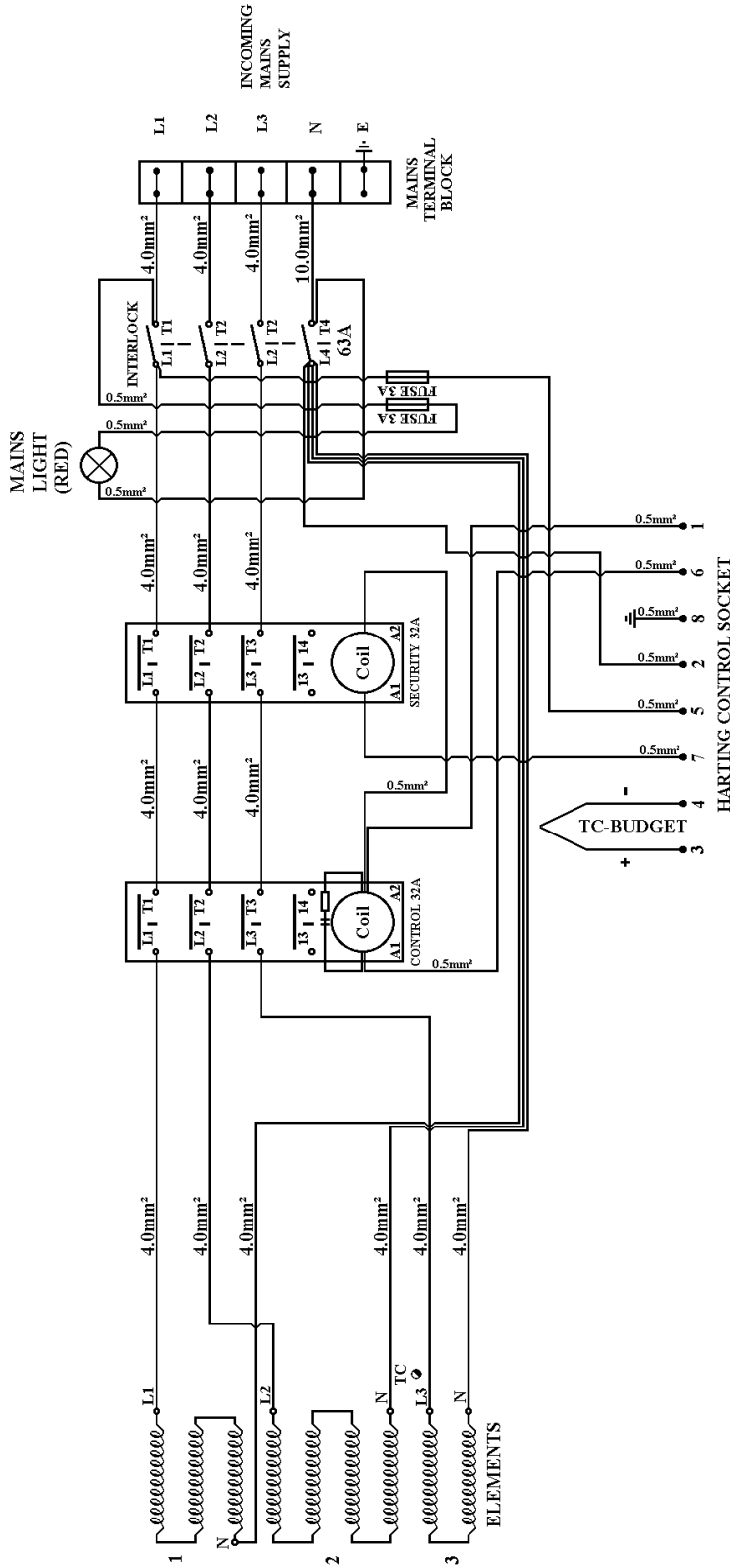

THE MAINS TERMINALS FOR THIS KILN ARE  
 LOCATED INSIDE THE KILNS FRONT BOX  
 APPROX 2/3 UP FROM THE BOTTOM.  
 DO NOT CONNECT MAINS DIRECTLY  
 TO THE CONTROLLER!

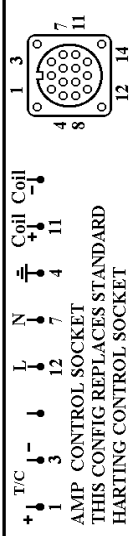

TITLE  
 MODEL TOPWORKER P5977n 13.116kW on 230v, (F) 12.0kW on 220v 1300°C  
 WIRING DIAGRAM 3+N+E

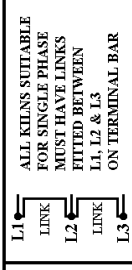

ALL KILNS SUITABLE  
 FOR SINGLE PHASE  
 MUST HAVE LINKS  
 FITTED BETWEEN  
 L1, L2 & L3  
 ON TERMINAL BAR  
 GROOVED

POTTERY CRAFTS LTD ©  
 CAMPBELL ROAD  
 STOKE-ON-TRENT  
 ST4 4ET  
 TEL 01782 745000  
 FAX 01782 746000  
 e-mail: enquiries@potterycrafts.co.uk

SUPPLY REQUIREMENTS			DATE
VOLTS	KW	SINGLE	THREE
220	12.0	63A	25A
230	13.116	63A	25A
240	14.281	63A	25A
DRAWN BY	APPROVED	DATE	
J CROSS	M WINT	28-05-2010	
DRG No	REV		
PC 109-2010			

HARTING CONTROL SOCKET  
 NOTE: ALL METALLIC SURFACES ARE BONDED



DRG No PC 111-2010

ALL INTERNAL WIRING TO BE IN SIAF CABLE

UK & OVERSEAS KILNS FITTED WITH 'R' TYPE THERMOCOUPLES  
 CERADEL KILNS FITTED WITH 'S' TYPE THERMOCOUPLES

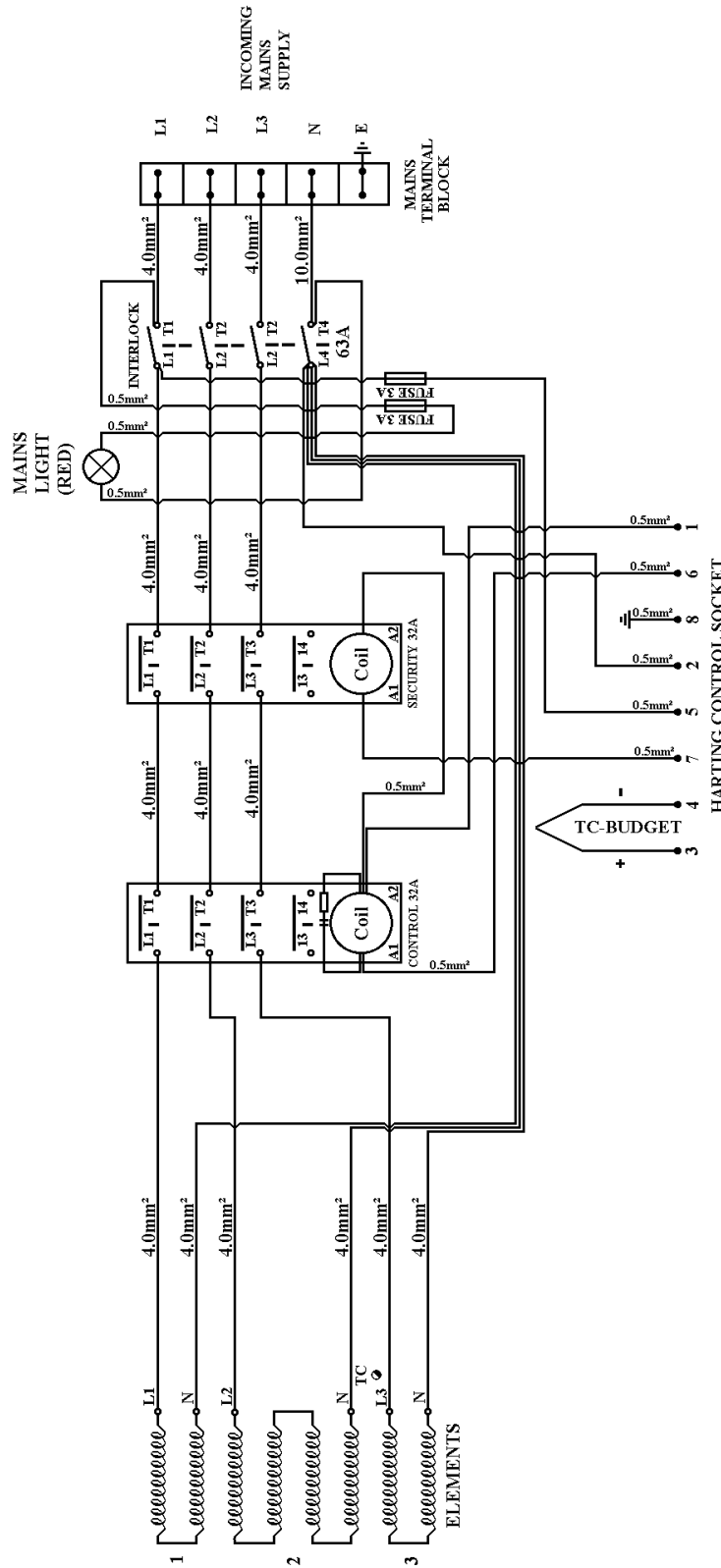

THE MAINS TERMINALS FOR THIS KILN ARE  
 LOCATED INSIDE THE KILNS FRONT BOX  
 APPROX 2/3 UP FROM THE BOTTOM.  
 DO NOT CONNECT MAINS DIRECTLY  
 TO THE CONTROLLER!

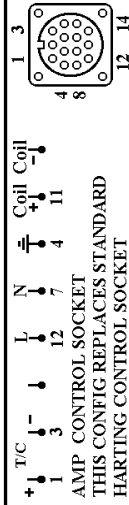

TITLE GROOVED

MODEL TOPWORKER P5959n 11.023kW on 230v, (F) 11.0kW on 220v 1300°C  
 WIRING DIAGRAM 3+N+E

ALL KILNS SUITABLE  
 FOR SINGLE PHASE  
 MUST HAVE LINKS  
 FITTED BETWEEN  
 L1, L2 & L3  
 ON TERMINAL BAR

POTTERY CRAFTS LTD ©  
 CAMPBELL ROAD  
 STOKE-ON-TRENT  
 ST4 4ET  
 TEL 01782 745000  
 FAX 01782 746000  
 e-mail: enquiries@potteryarts.co.uk

SUPPLY REQUIREMENTS		DATE
VOLTS	220	09-07-2010
KW	11.0	
SINGLE	63A	
THREE	20A	
	12.023	
	230	
	63A	
	240	
	13.091	
	63A	
DRAWN BY	J CROSS	APPROVED
DATE		M WINT
DRG No		REV
		PC 111-2010

NOTE! ALL METALLIC SURFACES ARE BONDED

HARTING CONTROL SOCKET

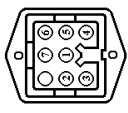

**THESE PAGES ARE FOR NOTES, OR YOUR OWN FIRING SCHEDULES:**





# FIRED UP KILNS

BY:  potterycrafts

## **Distributed By:**

Fired Up Kilns

hello@firedupkilns.com.au  
20 Helen Street, Heidelberg West,  
Victoria 3081, Australia  
www.firedupkilns.com.au  
ABN: 365 984 307 89

Fired Up Kilns works from the lands of the Wurundjeri Woi Wurrung and Bunurong peoples of the Kulin Nation and pay our respects to their Elders past and present.

We also acknowledge the Elders, Ancestors, cultures, and heritage of all Aboriginal and Torres Strait Islander Nations.