



FIRED ^{UP} KILNS

BY:



pottery**crafts**

Operating Manual Universal Electric Front Loading Kilns



All PotteryCrafts kilns are CE, ROHS and WEEE compliant



CONTENTS

Item	Page
1. Damage in Transit.....	2
2. Disposal of Old Electrical & Electronic Equipment.....	2
3. Safety warnings.....	3
4. Kiln Supply Voltage.....	3
5. Electrical Requirements.....	4
6. Safe Practice.....	5
7. Installation and positioning guide	6
8. General information regarding your kiln.....	7
9. Ventilation guide for electric kilns.....	8 - 9
10. Unpacking your new kiln	10
11. Kiln Components	11
12. Auto Damper.....	12–13
13. Manual Damper.....	14
14. Heat Lock.....	15
15. Batt / kiln wash.....	16
16. Furniture stacking placement	16
17. Kiln commissioning / Element Oxidation Firing.....	17
18. Preset firing schedules on controller.....	18–19
19. Reduction firing.....	20
20. Kiln maintenance / Servicing.....	20
21. Troubleshooting guide.....	21
22. Repair instructions.....	22–25
23. Wiring diagrams.....	26–31
24. Contact details.....	32

DAMAGE IN TRANSIT

Unpack and inspect kiln as quickly as possible saving all packaging, should any damage be found when unpacking you PotteryCrafts kiln please follow these instructions:

Contact the Dealer from whom you purchased the kiln within 24 hours with details of the damage to the kiln.

Do not assemble or attempt to fire the damaged kiln until it has been inspected. Check that the heating elements are securely in their grooves. If they have come out in transit place them back into their grooves taking care not to over-stretch them or damage the kilns brickwork. Note! If you do not correctly insert the elements into the grooves they will sag and stretch during firing which will reduce their working life.

DISPOSAL OF OLD ELECTRICAL & ELECTRONIC EQUIPMENT



This symbol on the product or on its packaging indicates that this product (including batteries) shall not be treated as household waste. Instead it shall be handed over to the applicable collection point for the recycling of electrical and electronic equipment. By ensuring this product is disposed of correctly, you will help prevent potential negative consequences for the environment and human health, which could otherwise be caused by inappropriate waste handling of this product. The recycling of materials will help to conserve natural resources.

For more detailed information about recycling of this product, please contact your local government body, your household waste disposal service, or the place where you purchased the product.



SAFETY WARNINGS

WARNING! Read all safety warnings and all instructions.

Failure to follow the warnings and instructions listed below may result in electric shock or serious injury.

- It is imperative that the kiln be on a level floor, and allowed to settle for a minimum of 24 hours before it is fired for the first time to reduce the risk of brick cracking.
- Disconnect power supply before attempting any maintenance or moving, servicing must be carried out by a qualified electrician, preferably a kiln engineer.
- Do not allow the mains cable or controller cable to meet the body of the kiln during firing as this will become hot and may cause damage to the cables. Never use the cord to pull the kiln around, a damaged cord increases the risk of electric shock.
- The stainless-steel jacket may discolour from both the heat and gases released by the pieces being fired. Use a cleaning agent suitable for stainless steel or glass to keep the kiln jacket clean.
- Do not open the kiln door/lid until it has cooled to at least 100°C, the door bricks expand and will grip the door jambs, if forced open the bricks can become damaged. Opening the kiln while hot can also cause the elements to bunch or come out of the grooves.
- Do not operate the kiln on a wet surface or in a damp atmosphere or area that can generate heavy condensation. **Water entering a kiln will increase the risk of electric shock!**
- Never attempt to fire higher than the temperature stated on the data plate, please note all our kilns are made from materials designed to withstand heatwork to cone 10, this should not be exceeded.
- Only fire products in the kiln where the properties and melting temperatures are known.
- To avoid burns and fire damage wear protective gloves if the handle needs to be touched during operation.
- The observation Hole Plug and side bung is a hollow ceramic and must be treated with care.
- Keep the area around the kiln free of clutter and never put flammable material against the kiln and preferably not in the kiln room.
- Ensure that the kiln room has adequate ventilation to remove fumes and avoid overheating. See the section on Ventilation page 9.

10A Models:

Please ensure that the distance between the mains fuse board and the 10A socket is as short as possible to reduce mains voltage drop.

extension leads should not be used doing so will void your warranty.

Note! When the lid is opened the controller will be powered down and the elements will cease to operate but will still remain hot.

Always supervise the first firings of a new kiln and always check at the appropriate time to ensure that the kiln has shut off.

KILN SUPPLY VOLTAGE

PotteryCrafts kilns sold into the UK and Australia are rated for use on a 230 / 400v electrical supply, overseas kilns are rated in accordance with the respective countries voltage. A kiln must be connected to the correct electrical supply to ensure correct and safe operation. If a kiln is connected to an electrical supply of low voltage this will reduce the top temperature capability of the kiln and reduce the kilns firing speed..

ELECTRICAL INSTALLATION REQUIREMENTS

- Incorrect installation of a kiln can be dangerous; it is legally required that only a kiln engineer or qualified electrician installs and checks the connection in your house / studio.
- Check that the details of the electricity supply and voltage as shown on the kiln data plate attached to the kiln conform to the type of supply available.
- All kilns must have a valid earth connection.
- All electrical connections must be secure and tight to prevent arcing and connections burning off.
- Please note that any damage caused by incorrect connection would not be covered by warranty.
- Only kilns operating from a 15/20 amp supply are supplied with cable and plug, all others are supplied with conduit and cable to connect the kiln to electrical circuit via qualified electrician.
- The electrician should ensure that grommets or glands are used when passing cables through the metal casing.



Isolator Label

Each kiln must have a separate isolator switch which must be clearly labelled identifying the kiln that it refers to; i.e. "Kiln 1" or "Kiln 2". The isolator must be positioned to allow clear and easy access to it without touching the kiln. The isolator must comply with current regulations for electrical safety at the time of installation.

Kiln-On Warning

Some authorities require a red warning light to be fitted outside the kiln room which should be illuminated when the kiln is firing. Alternatively a notice stating that the kiln is in use should be placed on the kiln room door. The position should be immediately visible to emergency services alerting them to presence of high powered electricity in case of emergency.

Isolator Label

Each kiln must have a separate isolator switch which must be clearly labelled identifying the kiln that it refers to; i.e. "Kiln 1" or "Kiln 2". The isolator must be positioned to allow clear and easy access to it without touching the kiln. The isolator must comply with current regulations for electrical safety at the time of installation.

Kiln-On Warning

Some authorities require a red warning light to be fitted outside the kiln room which should be illuminated when the kiln is firing. Alternatively a notice stating that the kiln is in use should be placed on the kiln room door. The position should be immediately visible to emergency services alerting them to presence of high powered electricity in case of emergency.

WORK AREA SAFETY

Keep area clean and well lit.

Cluttered or dark areas invite accidents

Do not operate kilns in explosive atmospheres, such as in the presence of flammable liquids or gases.

Keep children, pets and bystanders away from the kiln whilst in use.

PERSONAL SAFETY

Stay alert, watch what you are doing and use common sense when using a kiln. Do not use a kiln whilst tired or under the influence of drugs, alcohol or medication. A moment of in-attention whilst operating a kiln may result in serious personal injury.

Use personal protective equipment recommended when stated clearly in this instruction manual, Do not overreach when lifting or placing kiln furniture or ware during loading or unloading of the kiln.

What is an electric pottery kiln?

Kilns are chambers designed to contain heat so that temperatures can be achieved sufficient for clay to be converted to ceramic. The source of heat in electric kilns is the heating elements, wire coils that produce heat as a result of resistance to the flow of electricity. They are similar to the elements in an electric fireplace within your home. The kiln chamber is constructed from insulation materials that contain the heat reflecting it back into the kiln. A kiln is in terms of components and build, an enclosed electric fire place.

Potterycrafts Kilns have the following safety features.

- Over-temperature safety cut-off devices with all kilns.
- Anti-spike electrical surge protection with all controllers.
- Power On light - red warning light illuminated when the kiln is powered up.
- Element On Lights - white lights that illuminate when power supplied to elements.
- Fuses - 3amp controller fuses fitted behind front panel of front loaders kilns
- Interlock - switches off power to elements before opening the door, essential safety equipment. Kiln won't work if not in place.

Safe Practice

- Interlocks and Lid Safety switches prevent power from reaching elements when the door is opened, these should never be over-ridden or tampered with.
- Door opening - opening when hot, i.e. in excess of 100°C may cause brickwork to crack. Front loaders with taper fit doors are held fast by expansion when hot, if forced open serious damage can be done to the brickwork.
- Ventilation - essential to have moving air for heat and fumes, see page 9.
- Supervision of firing – always supervise kiln firings. It is essential to supervise the first few firings of any new kiln.
- All current Potterycrafts kilns are fitted with over-temperature cut-off devices, which shut down the kiln in the event of a component failure causing the kiln to reach 20°C hotter than the target temperature.
- All current Potterycrafts controllers are fitted with anti-spike devices to help prevent damage caused by electrical surges.
- Despite the safety features, damage can still occur through poor programming, for example, earthenware fired to a stoneware temperature will melt and could destroy kiln bricks and elements—never fire clay or glazes where you do not know of their maturing temperature.
- Electrical Work – must only be carried out by a qualified electrician, as per UK law.

KILN INSTALLATION & POSITIONING

When the kiln is being installed, make sure that the room/space will house the kiln is dry, and water proof. Temperatures in this space should ideally be between +5°C / +50°C. The surface (floor or specialist stand) where the kiln is to be installed must be level to enable the kiln to stand upright.

Note! It is important that the minimum safety spacing as written below is adhered too at all times during the use of the kiln, with front loading kilns as different advice applies based on size and build type.

POSITIONING:

The minimum safety gap of 0.5m from any wall. A minimum of 0.7m at the rear of the kiln to enable a service engineer to access the wiring, when required or be able to undertake repairs if required. In some cases, the distance must be greater in order due to local conditions.

Be sure to allow sufficient space to fully open the kiln door, as standard front loading kiln doors open to the left, right hand opening can be available for an extra cost, please request this at time of enquiry before purchase, for an extra cost.

Some front loading kilns can be fitted with castors (this must be requested at time of purchase) if this is the case avoid excessive movement. Excessive movement of the kiln will cause the insulation bricks used in the chamber to crack, care must be taken when re-positioning the kiln. One or more of the castors will be lockable and the brake should be applied when firing the kiln.

CEILINGS:

Allow a minimum of 1.5 m between the top of the kiln (including ventilation hood if installed) and any ceiling whether false or otherwise; if the ceiling is made from combustible material this must be protected with heat resistant board fixed with a minimum 10cm gap between board and ceiling.

Any materials used must meet the fire safety A DIN 4102-1 guidelines to be used within the room where the kiln is to be installed.

FLOORING:

The flooring must be suitable to take the weight of the kiln plus any accessories such as stand or furniture. All pottery crafts electric kilns must be placed on a non-combustible surface (fire safety class A DIN 4102-1) example: Concrete, tiles, aluminium or steel.

The floor must be level, so the kiln can stand upright, if required a new concrete flooring must be laid and cured before the kiln is placed in its installation position before being connected to the electrical circuit.

It is imperative that the kiln be on a level floor, and allowed to settle for a minimum of 24 hours before it is fired for the first time to reduce the risk of brick cracking.

Damage can occur if these guidelines are not adhered too, voiding the warranty on the kiln.

KILN CAGES:

In some circumstances it is advisable to fit a cage around the kiln to prevent unauthorised persons from accessing the controls or touching the kiln jacket during the firing cycle. Cages must be earth-bonded and lockable with sufficient distance between cage and kiln. This must be enquired about at time of purchase, if you require one after your kiln has been delivered, please speak to a member of our sales team.

General Notes:

Any flammable materials such as packing materials or curtains / plastics must be kept away from the kiln, never leave anything on top of the kiln even when not in use. The kiln's power / controller cable must not be allowed to touch the kiln case.

Whilst kilns do not give off any fumes and much of today's pottery products are non-toxic, some ceramic products can release gasses / fumes. Therefore it may be necessary to extract these gasses / fumes. If the kiln cannot be ventilated naturally then mechanical extraction may be required, please refer to the ventilation section in this manual.

Kiln Jackets are Hot

The surface of kilns can become quite hot and after long firings to high temperatures could reach up to 150°C. Although this is well below combustible temperatures of materials like paper it is still hot enough to burn if in contact for more than a second or so; it is therefore important to ensure that children, pets and vulnerable people are supervised while in the vicinity of the kiln.

The minimum safety gap of 0.5m from any wall. A minimum of 0.7m at the rear of the kiln to enable a service engineer to access the wiring, when required or be able to undertake repairs if required. In some cases, the distance must be greater in order due to local conditions.

Be sure to allow sufficient space to fully open the kiln door, as standard front-loading kiln doors open to the left, right-hand opening can be available for an extra cost, please request this at time of enquiry before purchase, for an extra cost.

Some front-loading kilns can be fitted with castors (this must be requested at time of purchase) if this is the case avoid excessive movement. Excessive movement of the kiln will cause the insulation bricks used in the chamber to crack, care must be taken when re-positioning the kiln. One or more of the castors will be lockable and the brake should be applied when firing the kiln.



QUICK REFERENCE GUIDE FOR VENTILATION.

Poor ventilation of kiln rooms can cause problems of excess heat, fumes and can even cause the kiln to shut down. These problems are addressed at length in our notes: "Ventilation for Your Electric Kilns" if you would like a copy please see our support section o the website; in the meantime here are the key points.

Small kilns (up to 6 kW rating)

In a medium sized room, often the option of using a window for ventilation is found to be sufficient. If in doubt we advise that an extraction fan is fitted, and a suitable source of replacement air is made available from outside the building.

Medium Size Kilns from (6 to 15 kW rating)

In a medium to large room, an extraction fan and air bricks are recommended for the room. No guidelines are laid down for the ventilation of rooms containing electric kilns, however, as a general guide on air changes; around 20 - 40 air changes / hour, should suffice (refer to ventilation recommendations for kitchens within schools). If the room is small you may require more air changes to keep the temperature at a comfortable level. A canopy may need to be introduced and fitted directly above the kiln and connected to the extraction system. In conjunction with a source of air from outside the building, this arrangement provides a method of removing excess heat directly from the area around the kiln whilst providing the most effective method of removing any fumes. Pottery crafts Ltd would recommend consulting a ventilation company for their advice, one that deals with high temperature solutions for the catering or industrial purposes.

Large sized Kilns (15kW – 32kW rating)

In a medium to large room, an extraction fan system and air bricks are a required recommended minimum for the room. No guidelines are laid down for the ventilation of rooms containing electric kilns, however, as a general guide on air changes; around 20 - 40 air changes / hour, should suffice (refer to ventilation recommendations for kitchens within schools or educational institutions). If the room is small you may require more air changes to keep the temperature at a comfortable level, which should be average ambient temperature of your location. A canopy may need to be introduced and fitted directly above the kiln and connected to the extraction system, we can provide canopies designed specifically to fit our large kilns, please enquire with a member of our team for more details. In conjunction with a source of air from outside the building, this arrangement provides a method of removing excess heat directly from the area around the kiln whilst providing the most effective method of removing any fumes.

Fitting ducting / Extraction systems:

Pottery crafts Ltd would recommend consulting a ventilation company for their advice, one that deals with high temperature solutions for the catering or industrial purposes.

Ventilation for Electric Kilns

Constant air movement

An open window is probably OK for small kilns. A 200mm domestic extract fan is usually sufficient for larger sizes of kilns but even a massive industrial fan won't work *if there isn't any replacement air coming from outside - not just the next room - outside!*

Fumes and Excess Heat

Electricity does not produce fumes but clay/glaze and colour can be a bit smelly during the firing. The danger is unlikely to be greater than walking down a busy high street, but don't work in the room when the kiln is firing. Excess heat can cause the kiln controller to shut down as many are fitted with internal thermometers.

Heat/Smoke Detectors and Sprinkler Systems

Kilns cannot catch fire – *how could there be anything in them that burns they are designed specifically to contain heat.* Ensure that anything combustible is kept away from the kiln especially the flue and spy holes. Site heat and smoke detectors immediately *outside* the kiln room, do not have water sprinklers within range of the kiln.

Safety Advice for Electric Kiln Users

The function of an electric kiln is to contain heat; the external skin of the kiln is therefore kept to temperatures below point of ignition of substances such as paper. The only points where there is a direct heat source are the flue and spy/ventilation holes, these are protected by bungs. Electric kilns are therefore no more of a fire hazard than a domestic oven and are safe to operate providing common sense working practices and manufacturer's instructions are followed. We hope that the following notes will allay any worries, if you have any concerns please do not hesitate to contact our technical staff, if you purchased via distributor please contact them in the first instance.

UNPACKING YOUR NEW KILN.

When you come to unpack your new kiln there will be various bubble wrapped packages within the chamber of the kiln, and a schematic diagram of the internal wiring configuration.

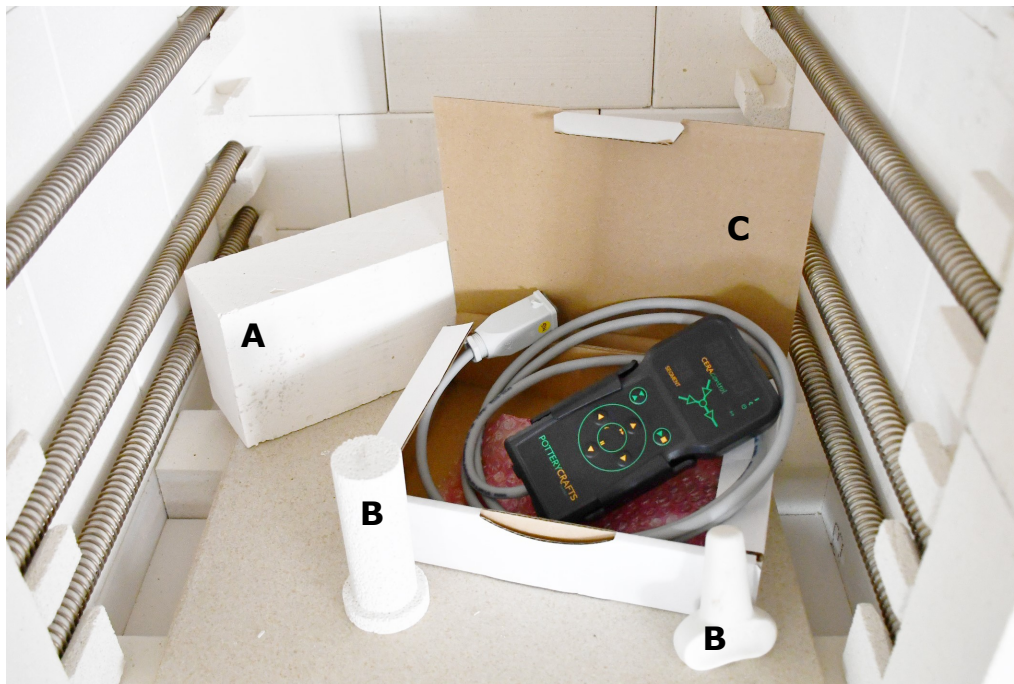

- A —flue top bung, for the roof of larger front loading models.
- B—either a porcelain or brick vent bung for the front of the kiln, item received dependent on model, some small models may also have a smaller bung than pictured.
- C —controller in box, with plastic bracket to affix to the wall / away from the kiln.
- Manuals in a separate package including the warranty and any other relevant information.
- Furniture set if purchased will be on the base on the pallet in separate packaging.

FURNITURE SET

The furniture will be placed on the pallet alongside your kiln.

In this furniture kit you should receive:

500g—1kg of batt wash dependent on model of kiln received

Batts correct for your kiln

Props in specific volume—see specific furniture set details on our website.

For how to place the furniture set within your kiln please refer to page— 12



Note! PotteryCrafts recommend batt wash be applied onto one side of each shelf and fired on before using the kiln for firing any work.

KILN COMPONENTS



Interlock Key Switch

The program controller will only be powered up and kiln will only work when the interlock key is in place. Captive key interlocks prevent the kiln being opened while connected to live power supply. The interlock key is fixed into a bracket at the base of the kiln door, positioned so that it fits into the lock in the kiln base when the door is closed. Push the key against the spring into the lock and turn 90° clockwise. Care must be taken not to force or damage the interlock especially when moving the kiln. It is a legal requirement to fit the interlock system, overriding it would condemn the kiln from use.

Flue or Vent Hole

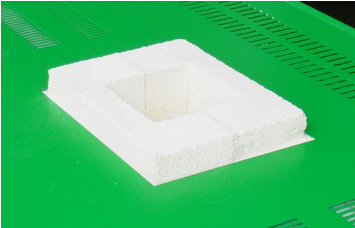

The kiln has a flue or vent hole on the top, this allows moisture to escape from the kiln chamber, with the flue closed moisture will penetrate through the brick and condensing on the inside of the kiln where it would cause corrosion to the kiln jacket. The flue also allows fumes to escape from the chamber creating a cleaner atmosphere. The flue should be closed with the bung provided at around 500°C to 600°C containing heat in the kiln. It can be removed when the firing is over to aid cooling. Potterycrafts PFL/AD Automatic

Damper automatically closes the flue at 550°C and reopens it at 200°C avoiding the necessity to attend the kiln at those times; please ask for more details.

Mains On Light

The red LED light on the front of the kiln under the door indicates that power to the kiln is switched on. Remember, the kiln will not operate until the interlock is in place.



Door Fastenings

Two screw clamps secure the door during firing, these should hold the door properly closed but must not be fastened too tight, over-tightening can cause the bricks to crack.



Thermocouple

The thermocouple is like a thermometer, it measures the temperature inside the kiln; it transmits the kiln temperature to the program controller throughout the firing.

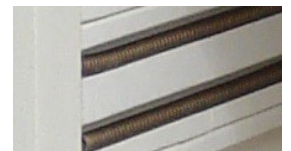

Heating Elements

Heating elements are wire coils, set within the kiln chamber either on refractory tubes or in brick grooves in the kiln walls. Elements heat up and glow radiating heat when connected power. Potterycrafts elements are made to industrial standards from specially formulated iron/chrome/alumina wire giving reliability at high temperature and long operating life.

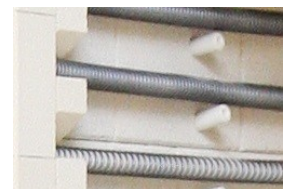

Connection of Controllers

All controllers supplied by Potterycrafts Limited are fitted with a multi pin plug, which will connect direct to a multi pin Harting socket fitted to all kilns. To connect the plug first check that it is the right way up push it in and press the retaining clip to secure it. The kiln will not operate unless the controller is properly installed.



AUTO DAMPER.

This is an optional product and may not be applicable to your particular model. This feature is available on our larger kiln options and must be included at request of order date.

The automated damper enables the user to run the kiln without needing to be present to close the bungs / flue at the top of the frame.

Front loading kilns have an open flue in the roof of the kiln with a brick damper to close it; the flue allows moisture and fumes to escape from the kiln in the early part of the firing and is then closed to conserve heat throughout the rest of the firing. With an Auto-damper you don't need to do anything, it operates entirely automatically closing and opening the damper during the firing, performing two important functions:

1. It eliminates the need to come back to the kiln during firing.

It removes the risk of the flue remaining open accidentally throughout the firing, (an open flue is the only point of fire hazard on an electric kiln).

The Auto-damper is pre-set to close when the kiln temperature reaches 550°C.

It is pre-set to open again once the firing cycle is complete and the kiln cools down to 250°C, these temperatures cannot be amended.

The motor, illustrated below, is mounted horizontally on top of the kiln and operates the damper, the motor is operated by an independent controller housed inside the rear of the kiln.

If for any reason the automated damper fails to close or to open at the preset temperature there is an over-ride button on the motor that disengages it from the damper shaft enabling the damper to be operated manually.

We strongly recommend that it is operated manually with great care as if it is incorrectly positioned it could result in the damper opening when it should be closed and vice versa, or causing damaged which is not covered under the warranty.

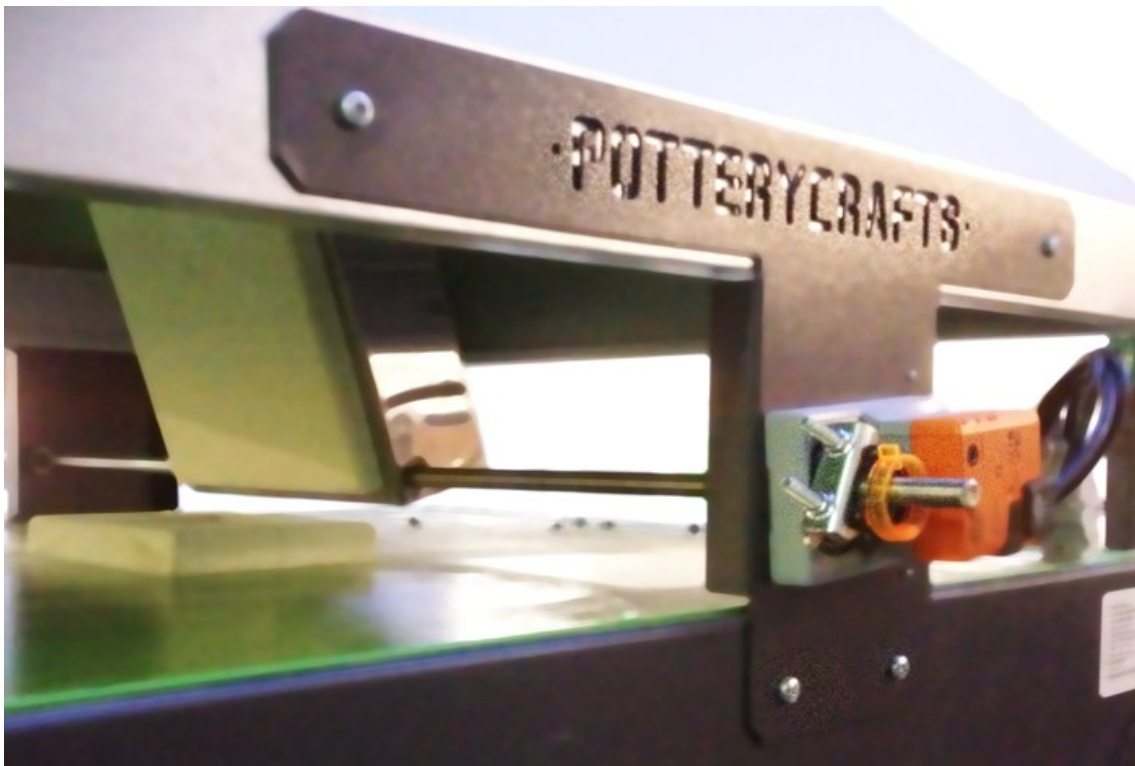

Pictured is the P5943 kiln with added ventilation hood and automated damper.

MANUAL DAMPER.

If your kiln is not purchase with an automated damper system in place then instead there will be a manual damper.

Depending on the model purchase you may not have a top flue, only a front spyhole or front small bung maybe required—subject to model size.

If you have a top flue it will look like one of the examples below and this should be closed at 500°C or above and then opened once the firing cycle is complete and cooled below 400°C to aid in ventilation, and air exchange.



A—brick top flue—insert the brick at the temperature stated above.



B—the damper is closed by a manual bar which assists the user due to the size and chamber volume of the kiln making it too large to reach without risk of burning to the user.

HEATLOCK

This is an optional product and may not be applicable to your particular model. This feature is available on our larger kiln options and must be included at request of order date.

The heat lock enables the user to run the kiln without the risk of it being opened during the firing or cooling cycle and is often recommended for use in educational settings and shared community studios for health and safety requirements where a kiln cage and or locked room for the kiln to fire in is not possible.

1. Prevents damage to the kiln door and frame caused when a hot kiln is opened while expanded brickwork is being gripped by the door jamb.
2. Eliminates the risk of burning because the door cannot be opened until the kiln has cooled down.

The lock is discretely positioned adjacent to the interlock key under the door of Potterycrafts front loading kilns.

it is operated by a small controller pre-set to lock at 65°C in the heating cycle and to unlock at 55°C on cooling.

A warning light indicates when the door is locked, when the light goes out it is safe to open the kiln.

The Potterycrafts front loading Heat Lock is failsafe, if the power is turned off it remains locked, the door can only be opened when powered up and the temperature has dropped to 55°C.

The Heatlock works automatically, the kiln operator does not need to do anything or amend the controller in anyway for this to run correctly.

Warning!

If your kiln has a heatlock and arrives to you locked please be aware that it will not open until such time it has been connected to the electrical circuit.

Forcing the door open can damage the mechanism and any such damage is not covered by the warranty.

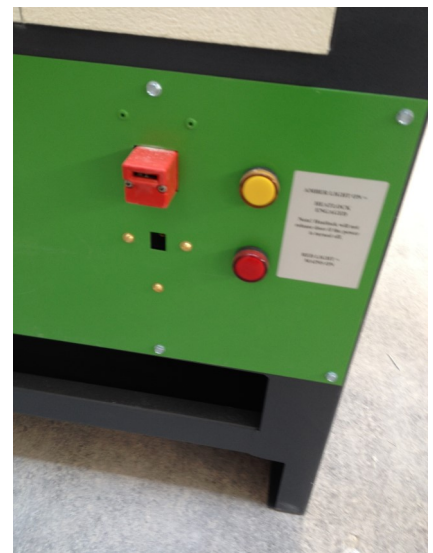

VENTILATION HOOD.

This is an optional product and may not be applicable to your particular model. It can be purchased after time of purchase as it is affixed to the external body of the kiln and adjoins the frame with existing location markers.

BATT / KILN WASH

Mix the Batt Wash with water to a single cream consistency. 50/50 ratio usually works well, add the water a small amount at a time until the correct consistency is achieved.

Apply with a wide brush to one side of any batt being used.

2-3 coats alternating the direction of application will be sufficient, allowing each coat to dry before applying the next to avoid peeling. This will prevent glaze from sticking to the shelves (batt wash should not be applied to the kiln walls or underside of the shelves or underside of lid). Let batt wash dry thoroughly before loading the kiln, firing it to a 1240°C or above firing will adhere it correctly.

FURNITURE STACKING PLACEMENT

The kiln is provided with furniture applicable to the size of the firing chamber, always place a floor batt (kiln shelf) on the base bricks to maintain an air space between the floor elements and the batt, and to ensure adequate ventilation of the floor elements.

Once you have applied your batt wash to one side of each kiln shelf you can then place them in the kiln as example below, allowing space for ventilation and air flow through the firing chamber.

For optimum performance and efficiency, the kiln should be loaded as follows:-

- Never place ware, or a batt, directly touching the elements.
- Use three props to each shelf to ensure greater stability.
- Spread the load equally throughout the kiln from top to bottom to prevent uneven heating.

When loading shelves into the kiln please be careful not to damage the thermocouple, (A) also do not place shelves / batts at the same level as the thermocouple as this can give a false temperature reading, be careful to not place work to near it as this can also affect the temperature reading gained during the firing cycle.

NOTE!: Please allow a minimum distance of 2.5cm (1 inch) between the ware/furniture and thermocouple as there is a risk of over-firing any item close to the element.

Note! New kiln furniture (e.g. plate sitters and supports) should be dried out by heating them once (as described above), to remove any excess moisture, burn out any binders that may be present, and other residue left over from the manufacturing process.



THE KILN PROGRAM CONTROLLER

Electronic controllers control the power input to the kiln, they regulate the rate of heating by switching the power on and off at longer or shorter intervals depending on the speed of heating required. They have a digital display of the temperature inside the kiln throughout the firing and a display indicating which segment is being operated showing progress through the program. Controllers are powered by the kiln and they are connected to a thermocouple, a probe poking into the kiln chamber which measures the temperature. Your controller will come with manufacturers operating manual.

OPERATING THE KILN

To operate the kiln close the door, put the interlock key in place and turn on the mains isolator. Your program controller should now be illuminated, select or input the required program and commence firing. See the separate controller instructions and advice on programming your kiln in this manual.

FIRST FIRING

Whilst the majority of your top loader kiln is dry built it is advisable to dry / test fire the kiln first, this will also help to form a clean oxide layer across the heating elements to maintain a good element working life. (Note! heating elements are coated in a protective film this will burn off during this first firing and can cause an unpleasant smell and some smoke may also be given off, as the protective coating is removed in this firing).

Any vent plugs should be left out for this 1st firing. Close the lid and engage the kilns interlock. This first firing should contain only the furniture set positioned in the kiln as if it was to be loaded with ware, to mimic a full kiln load and allow the temperature to be even throughout the firing chamber, if no furniture was present it can cause uneven temperature increases and can affect the element positioning.

Segment 1 ramp rate	Seg 1 target temp	Soak / dwell time	Seg 2 ramp rate	Seg 2 temp	Seg 2 soak / dwell	Seg 3 ramp rate
50c	100c	00.45 mins	150c	1240	00.00 hr soak	END

This is pre-set in your controller to PROGRAMME 1. programs in your controller for your fired up kiln are all pre-set—please see interleaf included.

Once this has completed allow the kiln to cool down naturally.

To enter the program shown above please read the instructions for the controller.

Note: New kiln furniture (e.g. plate sitters and supports) should be dried out by heating them once (as described above), to remove any excess moisture, burn out any binders that may be present, and other residue left over from the manufacturing process.

Preset Ceramics Programs

The CERACONTROL is provided pre-programmed with the ceramics firing programs below, specific to the Fired up Kilns. These programs may be modified or over-written as required.

Pg 1 – first kiln firing – run this programme as the first firing in your new kiln – it coats your elements in aluminium oxide which acts as a protective layer between the elements and fumes/vapours released from clay and glazes. Leave bungs IN until 1000c, then take bungs OUT for the rest of firing.

Pg 2 – slow bisque – for thick work which may be uneven in thickness – usually used when work will be then fired to stoneware temperatures. (If firing to earthenware temps for glaze use earthenware bisque)

Pg 3- medium bisque – for even thickness work / work which is completely dry.

Pg 4- earthenware glaze/ high bisque – first firing for work which is made with earthenware clay

(lower temperature) Use this firing to bisque work which uses low fire glazes (1020 – 1080 glaze)

Pg 5 – Mid-fire (cone 6)

Pg 6 – Stoneware (cone 9-10)

Pg 7 – Lustre/Decal (Earthenware/Bone China) - used after a bisque and glaze firing to apply metals or on-glaze decals to work. See manufacturer's advice for specific temperature on products.

Pg 8 – Lustre/Decal (Stoneware/Porcelain) – used after a bisque and glaze firing to apply metals or on-glaze decals to work. See manufacturer's advice for specific temperature on products.

Pg 9 – Candling (Drying) – Candling program to run prior to bisque firing/to dry out wares

pg 10 - empty

REDUCTION FIRING

This kiln is NOT suitable for reduction firing. Any such firing will void the warranty on your kiln.

KILN MAINTENANCE / SERVICING

Regular cleaning of the inside to remove debris from both the chamber and element grooves will help to increase the working life of your kiln.

Attention: Do not knock the heating elements when cleaning as this can break them.

Note! As the heating elements age they will lose efficiency resulting in extended firing times and a lower top temperature capability, when this happens the elements will need to be renewed.

It is advised that the kiln be serviced annually by a qualified electrician.

We would advise that your kiln be service / inspected annually to ensure years of good service. This can either be done by PotteryCrafts service engineer or via one of our appointed engineers. Below is a list of items checked in the annual service.

- Kiln location inspection (no flammable items etc near kiln).
- Exterior examination for signs of corrosion or other external hazards.
- Interior check of brick lining.
- Element visual inspection.
- Kiln control box (damaged cables, brittle, burnt cables / damaged ends terminations tight etc).
- Safety switch testing.
- Element load and voltage test.
- Controller function test.

Upon inspection a certificate can be issued for your Health & Safety file.

Only a qualified electrician may carry out work on a kilns electrical system.

TROUBLESHOOTING GUIDE

Error	Cause	Error Elimination / Cure
Controller does not switch on.	No voltage or controller is defective. Interlock key not in Place.	Check / replace mains fuse. Check / replace fuse in controller. Check plug fuse. Interlock, put interlock in place.
Controller shows error	See controller instructions.	
Kiln does not heat when the program has been started	Programming error.	Check program entered :- is there a delay Start programmed. See controller instructions.
Very slow heating of the kiln?	Heating element broken Contactor pole failure	Test elements and replace if necessary Replace contactor. Program.
Top temperature is not reached.	Heating element broken Low voltage.	Replace heating elements. Check voltage & contact Pottery crafts.
Fuse melts immediately after kiln is switched on.	Short circuit - Overloaded circuit.	Have the wiring checked. Disconnect any other appliances from the circuit.
New element has burnt out In the chamber.	Glaze on element. Batt wash on element. Debris from old element. Pot / shelf contact with elements.	New element required. New element required. Clean groove before fitting new element.
New element burnt out in control box.	Connection not tight enough.	Replace element, tighten pins.
Kiln overfires.	Jammed contactor or relay.	Replace contactor or relay.
Ware keeps breaking.	Heating / cooling ramp too fast.	Slow down heating / cooling speed of kiln.
Kiln gives off nasty odour.	The ware burning off impurities New elements burning off coating.	This will clear.

REPAIR INSTRUCTIONS

Only a qualified electrician may carry out work on the electrical system!

Ordering spare parts

Before contacting your distributor of your kiln please have with you the following information from the kilns data plate:

Model
kW loading
Serial Number
Year of manufacturer

We can be contacted either by phone or Email:

Fired up kilns Australia.
Factory 39,
10 Cawley Road,
Yarraville Victoria 3013,
Australia

Tel:
Within Australia: [0473 748 870](tel:0473748870)
Outside Australia: [+61 473 748 870](tel:+61473748870)

enquiries@firedupkilns.com.au

Safety advice

The kiln contains ceramic fibre blanket as a backup material. This material is an irritant and should not be handled unless working in a well ventilated area with suitable protective personnel equipment such as a protective suit, gloves and breathing mask.

KILN SERVICING AND MAINTENANCE

Heating Elements

The kiln is equipped with iron-chromium-aluminium, commonly known as Kanthal A1 elements, suitable for high fire use.

Kiln elements become brittle after a few firings, so care should be taken if handling is necessary.

Check which element has failed. This will probably be obvious by inspection: look for burn marks or slag on the brickwork where arcing may have occurred at the break point. Failing this, undertake a paper test on the elements, Number the pieces of paper, marking small pieces of paper that fit behind the element at the start, middle and end of each line of element. Close the chamber, initiate the kiln for 2-3 minutes, and then stop the programme. Open the chamber and see which elements have left a burn mark, if they have not, or it is substantially less marked than others then this tells you elements need to be replaced.

Replacing Elements - Front Loading Kilns

WARNING — BEFORE CARRYING OUT WORK OF ANY NATURE ON THE KILN ENSURE THAT IT IS COMPLETELY DISCONNECTED FROM THE MAINS SUPPLY. FAILURE TO OBSERVE THIS PRECAUTION COULD RESULT IN SEVERE INJURY OR EVEN DEATH.

1. Remove the connecting chamber rear cover.
2. Disconnect the faulty element and withdraw it from inside the kiln.
3. Check the element support grooves in the kiln. They must be complete and unbroken and should be vacuum-cleaned or brushed out to remove all foreign matter. Every piece of burnt brick, slag etc., from previous failures must be completely removed and made good (see Refractory Brickwork section). Failure to do this can result in immediate breakdown of the new element.
4. Check that the hairpin fits its grooves with the coils in position. Ensure that the coils are parallel in both the vertical and horizontal planes, and that the hairpin is at right-angles to the coils.
5. Ensure that the element will lie flat in its grooves when the lead-tails are inserted through the lead holes at the rear of the kiln. Adjust if necessary. Avoid the use of pliers since the surface of the wire can be damaged resulting in premature breakdown.
6. Push the lead-tails through the lead holes and lay the element into its grooves. Pull the element back and fit the hairpin into its channel. Check that the element lies flat and true in the grooves.
7. Pull the lead-tails through the back of the kiln until the coil butts up to the back wall.
8. Refit brass connector where required and connect to the element connectors. We always recommend fitting a new connector, where possible.
9. Make sure that all electrical connections are properly completed and, with the electricity supply still switched off, check that there is an adequate and tested earth wire connected to all metal casings including the kiln itself and that the fuses are of the correct type.
10. It is important that a pre-oxidising firing is carried out after the installation of new elements to a temperature of round 1100°C.
11. Recommended periodic checks - Check that all elements connections are tight (they can work loose as a result of vibration caused by AC mains voltage supply).

Refractory Brickwork

Refractory bricklaying is an extremely specialised operation and apart from simple tasks, such as filling cracks and fitting floor bricks, replacement of kiln refractories should be undertaken only by a qualified craftsman.

Cutting Brick Shapes

It is essential that refractory bricks are a tight fit with thin joints and for this reason each brick should be cut to precise shape and size to fit the repair. Pottery crafts Limited are able to supply a range of refractories for cutting to size and to suit various maximum temperatures. Refractory bricks are easily cut with a coarse wood-saw, hacksaw blade or similar tool. Measure the size and shape required and mark the brick as a cutting guide. Cut approximately 2mm (1/16")

oversize and rub down to precise fit with coarse carborundum stone. Holes can be gouged through with a twist drill or screwdriver and enlarged if necessary, with a rasp.

Repairing the insulation brick

- Disconnect kiln from the mains / remove plug.
- Cut out a rectangle around the damaged area of brick.
- Remove any dust residue with a vacuum cleaner.
- Fit in a new piece of brick using a refractory cement to bond it, once this has set use a rubbing stone or abrasive to shape the brick as required.
- Remove again any dust residue with a vacuum cleaner.
- If a complete brick need to be changed remove the lid and then using the jacket tensioners release the pressure on the brick sufficiently to allow the damaged one to be removed. (Please be very careful when doing this as you may break the elements in the kiln).

Kiln Floor Refractory Bricks - (Front Loading Kilns)

Kiln floor bricks are fitted loose, without cement.

Cracks in Refractory Bricks

Fine cracks in the brickwork are inevitable but are not detrimental to the operation of the kiln. They act as expansion joints, closing during the heating of the kiln and opening again on cooling. It is not advisable to scratch out and fill such cracks with cement.

Damage Due to Element Failure

On occasions following the failure of a heating element, arcing will occur between the broken ends of the element, resulting in a deposit of slag in the refractory brickwork. This slag must be removed, otherwise early failure of the new element will almost certainly occur. Small deposits of slag can be picked or gouged out and the groove made level with brick dust or a mixture of brick and dust and air-setting cement (about 50/50). Silica sand, fireclay or other materials containing iron should NOT be used as they will damage the elements at high temperature. If the element groove is broken or burnt, the damaged portion of brickwork will require replacement.

Replacing A Contactor

Disconnect kiln from the mains / remove plug.

Using the Phillips screwdriver remove the front panel from the control box.

Using a screwdriver remove the contactor fixing pins.

Swap over the terminals one at a time from the old contactor to the new making sure the contacts are secure. Please ensure that only load carrying terminals are used and not the auxiliary terminals and that the suppressors are also fitted correctly.

Using a screwdriver secured the contactor. Re-attach the panel to the control box.

TEMPERATURE LIMITATION AND CONTROL

Over-firing and/or overwork are two of the main causes of element failure. The Potterycrafts range of kiln accessories includes a number of controls specifically designed to overcome or alleviate these problems.

Potterycrafts Kilns are designed and built for effective and reliable use and will give good service with the minimum attention. They are subjected to extensive tests and inspections before despatch and, in common with all other Potterycrafts products, are backed by a fast and efficient aftersales service.

Replacing A Thermocouple

Disconnect kiln from the mains / remove plug.

Using the Phillips screwdriver remove the front panel from the control box.

Remove the thermocouple locating pin.

Remove the white and orange ends of the compensating cable from the porcelain block on the thermocouple.

Remove the damaged thermocouple and replace with new one.

Connect compensating cable to thermocouple porcelain block (orange = +, white = -).

Using a screwdriver secure the thermocouple with the locating pin.

Re-attach the front panel to the control box.

Note! *always replace the thermocouple with an identical unit, if your kiln is fitted with the wrong type of thermocouple this could result in an over-fire.*

Over-firing

With complete over-firing, refractories will shrink and have a burnt appearance which will impair their insulating properties. As it is unsatisfactory to mix new and over-fired refractories in a small kiln, it is recommended that the kiln be completely rebuilt.

Firing After Repair

The kiln should be fired slowly after refractory work has been carried out to allow the cement joints to dry out and set. The firing rate should not exceed 100°C per hour.

Cleanliness of the Kiln

Ideally, the kiln and particularly the element grooves, should be cleaned after every firing. A vacuum cleaner is the safest and most efficient implement for this purpose, as it will remove all dust accumulated during firing, without contacting the element spirals or brickwork.

Whatever method is employed, great care must be exercised to avoid damage to the element wire.

It is also important to keep bats clean by chipping-off glaze residue immediately after firing. Glaze-stained bats, particularly if turned upside down, may drip onto floor elements causing damage to the kiln.

Warranty

For your product warranty and information about how to register your warranty please see separate documentation which was provided with your kiln at time of purchase. If you do not have a copy of this please see our website—support section.

DRG No PC 12A-2011

ALL INTERNAL WIRING TO BE IN SIAF CABLE

UK & OVERSEAS KILNS FITTED WITH 'R' TYPE THERMOCOUPLES
 CERADEL KILNS FITTED WITH 'S' TYPE THERMOCOUPLES

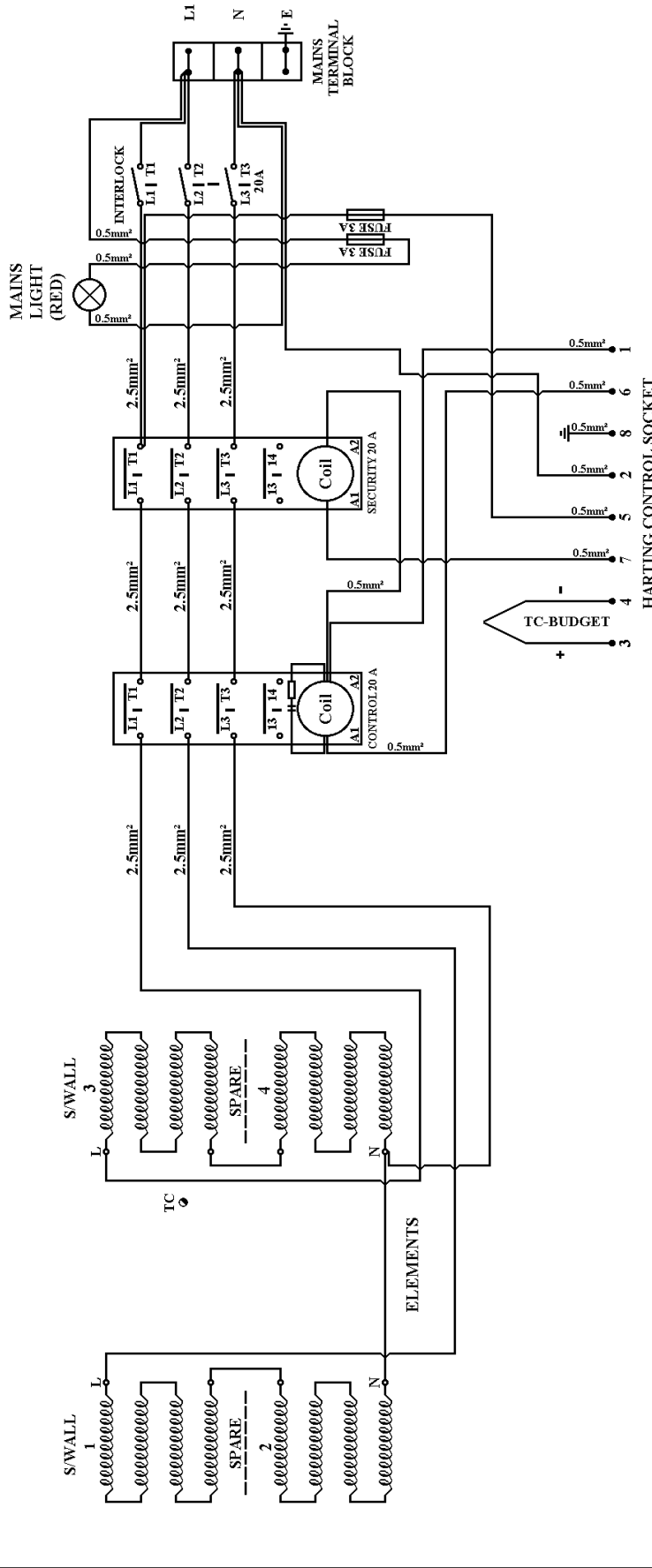

HARTING CONTROL SOCKET

NOTE: ALL METALLIC SURFACES ARE BONDED

<p>POTTERY CRAFTS LTD CAMPBELL ROAD STOKE-ON-TRENT ST4 4ET TEL 01782 745000 FAX 01782 746000 e-mail: enquiries@potterycrafts.co.uk</p>		<p>DATE 01-03-2011</p>
<p>DRAWN BY J CROSS</p>	<p>APPROVED M WINT</p>	<p>REV</p>
<p>DRG No PC 12A-2011</p>		<p>TITLE FIREWORKER P5910 4.5kW 1300°C, C50-ECO 3.45kW 1100°C, C50 5.0kW 1300°C + LIGHT WIRING DIAGRAM 1+N+E</p>
<p>ALL KILNS SUITABLE FOR SINGLE PHASE MUST HAVE LINKS FITTED BETWEEN L1, L2 & L3 ON TERMINAL BAR</p>		<p>GROOVED</p>
<p>T/C + 1 3 - 1 3</p>	<p>Coil + 4 11 - 4 11</p>	<p>AMP CONTROL SOCKET THIS CONFIG REPLACES STANDARD HARTING CONTROL SOCKET</p>
<p>L1 LINK L2 LINK L3</p>		<p>TC 1 3 4 8 11 12 14</p>

DRG No PC 13A-2011

ALL INTERNAL WIRING TO BE IN SIAF CABLE

UK & OVERSEAS KILNS FITTED WITH 'R' TYPE THERMOCOUPLES
 CERADEL KILNS FITTED WITH 'S' TYPE THERMOCOUPLES

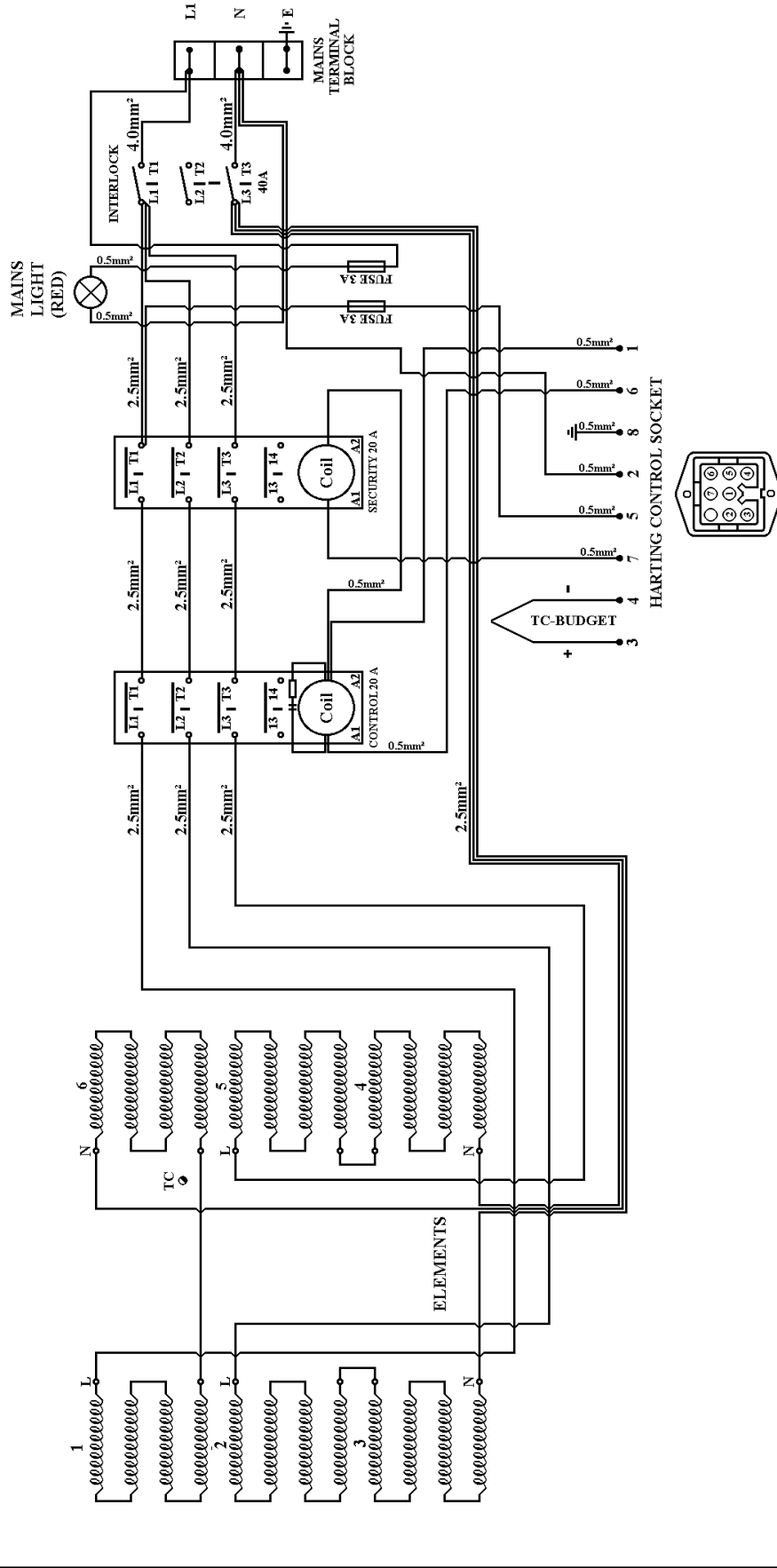

HARTING CONTROL SOCKET

NOTE! ALL METALLIC SURFACES ARE BONDED

<p>POTTERY CRAFTS LTD © CAMPBELL ROAD STOKE-ON-TRENT ST4 4ET TEL 01782 745000 FAX 01782 746000 e-mail: enquiries@pottery crafts.co.uk</p>		<p>DATE 05-05-2011</p>
<p>DRAWN BY J CROSS</p>	<p>APPROVED M WINT</p>	<p>REV</p>
<p>TITLE FIREWORKER PS911 (F) C68 5.5kW 1300°C + LIGHT WIRING DIAGRAM 1+3+N+E</p>		<p>DRG No PC 13A-2011</p>
<p>ALL KILNS SUITABLE FOR SINGLE PHASE MUST HAVE LINKS FITTED BETWEEN L1, L2 & L3 ON TERMINAL BAR</p>		<p>GROOVED</p>
<p>T/C 1 3 AMP CONTROL SOCKET THIS CONFIG REPLACES STANDARD HARTING CONTROL SOCKET</p>	<p>Coil Coil N L 12 7 4 11</p>	<p>1 3 7 11 4 8 12 14</p>

DRG No PC 14-2009

ALL INTERNAL WIRING TO BE IN SIAF CABLE

UK & OVERSEAS KILNS FITTED WITH 'R' TYPE THERMOCOUPLES
 CERADEL KILNS FITTED WITH 'S' TYPE THERMOCOUPLES

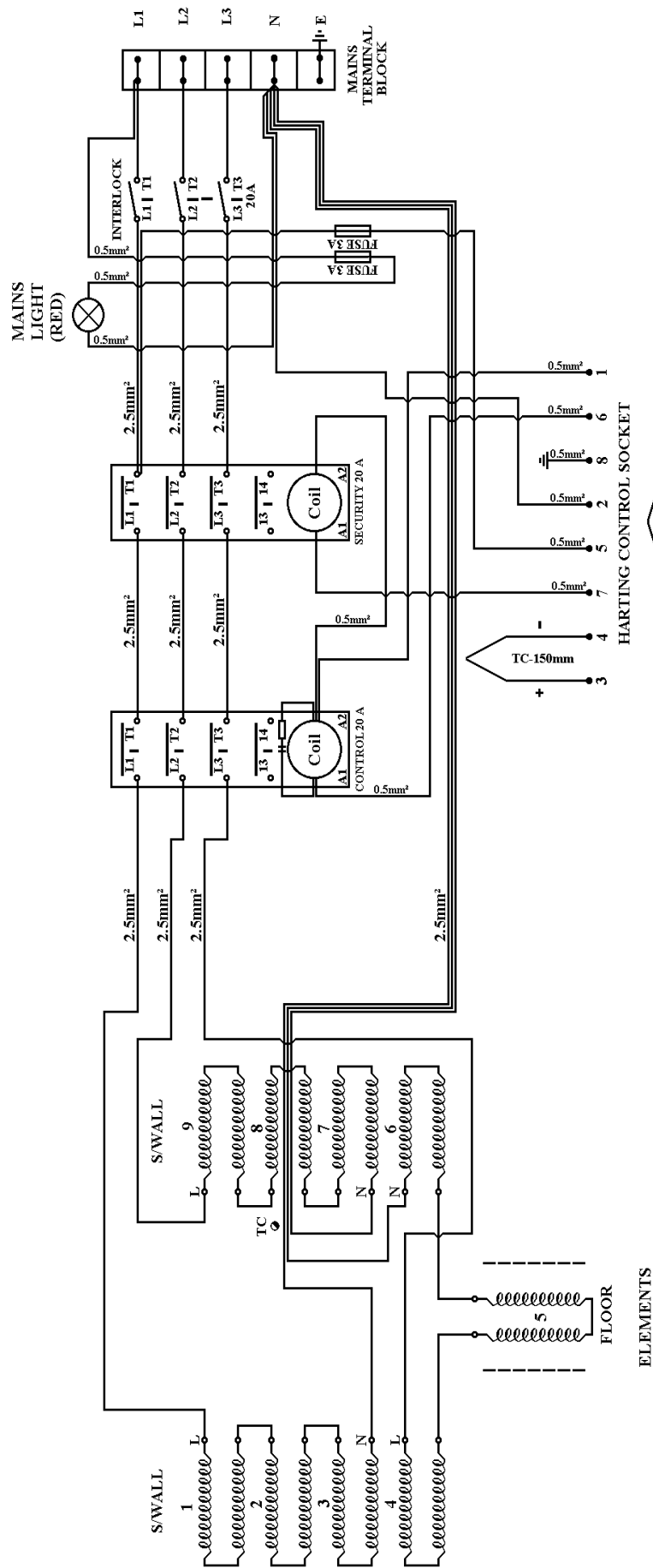

THE MAINS TERMINALS FOR THIS KILN ARE LOCATED INSIDE THE LARGE PANEL AT THE REAR OF THE KILN APPROXIMATELY 30cm UP FROM FLOOR HEIGHT. DO NOT CONNECT MAINS DIRECTLY TO THE CONTROLLER!

<p>TC + 1 3 - 1 3 N 7 L 12 Coil + 4 - 11</p>	<p>AMP CONTROL SOCKET THIS CONFIG REPLACES STANDARD HARTING CONTROL SOCKET</p>	<p>L1 LINK L2 LINK L3 LINK</p>	<p>ALL KILNS SUITABLE FOR SINGLE PHASE MUST HAVE LINKS FITTED BETWEEN L1, L2 & L3 ON TERMINAL BAR</p>
<p>TUBED</p>			
<p>MODEL HEATWORKER P5941 (F) C86 6.0kW 1300°C WIRING DIAGRAM 3+N+E</p>			
<p>TITLE</p>		<p>POTTERY CRAFTS LTD © CAMPBELL ROAD STROKE-ON-TRENT ST4 4ET TEL 01782 745000 FAX 01782 746000 e-mail: enquiries@potterycrafts.co.uk</p>	
<p>DATE 07-05-2009</p>	<p>APPROVED M WINT</p>	<p>DRAWN BY J CROSS</p>	<p>REV PC 14-2009</p>

NOTE: ALL METALLIC SURFACES ARE BONDED

HARTING CONTROL SOCKET

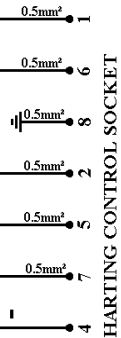
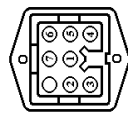

DRG No PC 15-2009

ALL INTERNAL WIRING TO BE IN SIAF CABLE

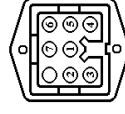
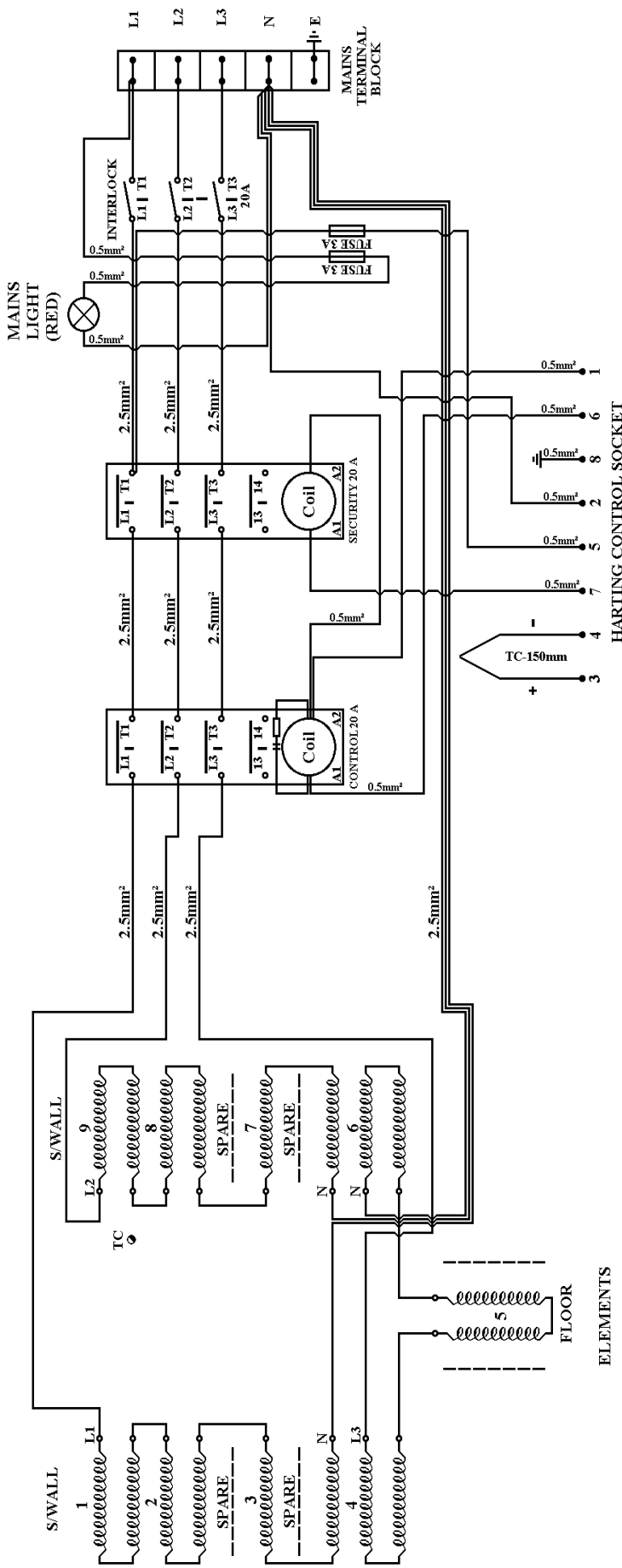

THE MAINS TERMINALS FOR THIS KILN ARE LOCATED INSIDE THE LARGE PANEL AT THE REAR OF THE KILN APPROXIMATELY 30cm UP FROM FLOOR HEIGHT. DO NOT CONNECT MAINS DIRECTLY TO THE CONTROLLER!

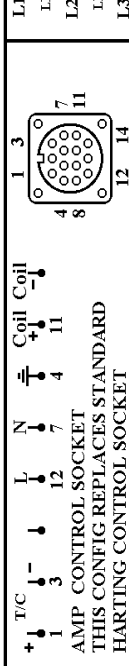

TITLE: HEATWORKER PS942 (F) C128 7.5kW 1300°C
 MODEL: WIRING DIAGRAM 3+N+E

ALL KILNS SUITABLE FOR SINGLE PHASE MUST HAVE LINKS FITTED BETWEEN L1, L2, & L3 ON TERMINAL BAR

TUBED

POTTERY CRAFTS LTD ©
CAMPBELL ROAD
STOKE-ON-TRENT
ST14 4ET
TEL 01782 745000
FAX 01782 746000
e-mail: enquiries@potterycrafts.co.uk

DATE	07-05-2009
APPROVED	M WINT
DRAWN BY	J CROSS
DRG No	PC 15-2009
REV	

NOTE! ALL METALLIC SURFACES ARE BONDED

DRG No PC 17-2009

ALL INTERNAL WIRING TO BE IN SIAF CABLE

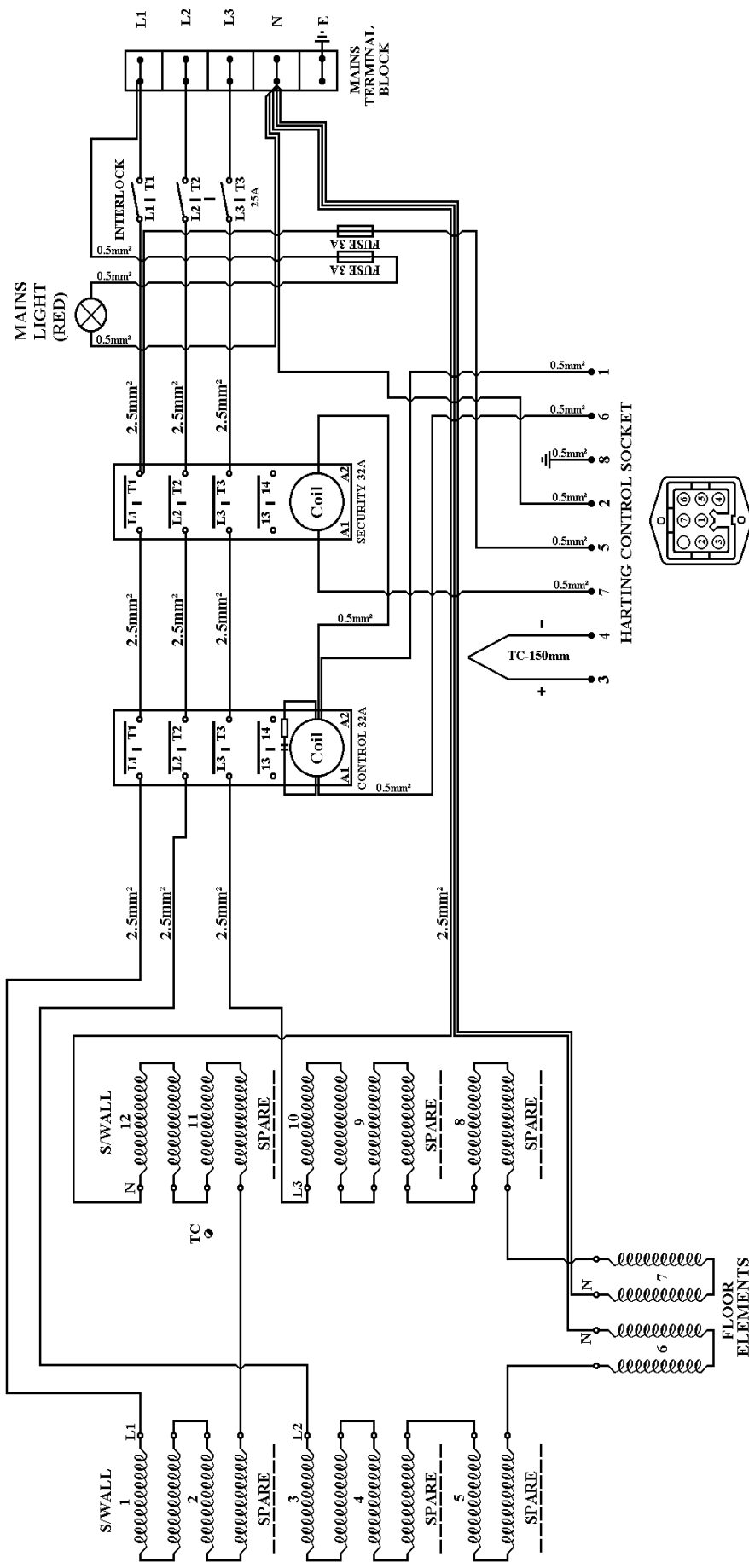

THE MAINS TERMINALS FOR THIS KILN ARE LOCATED INSIDE THE LARGE PANEL AT THE REAR OF THE KILN APPROXIMATELY 30cm UP FROM FLOOR HEIGHT. DO NOT CONNECT MAINS DIRECTLY TO THE CONTROLLER!

HARTING CONTROL SOCKET

NOTE! ALL METALLIC SURFACES ARE BONDED

<p>DATE 07.05.2009</p>	<p>APPROVED M WINT</p>	<p>DRG No PC 17-2009</p>
<p>DRAWN BY J CROSS</p>	<p>POTTERY CRAFTS LTD © CAMPBELL ROAD STOKE-ON-TRENT ST4 4ET</p>	<p>ALL KILNS SUITABLE FOR SINGLE PHASE MUST HAVE LINKS FITTED BETWEEN L1, L2 & L3 ON TERMINAL BAR</p>
<p>REV</p>	<p>TEL 01782 745000 FAX 01782 746000 e-mail: enquiries@pottery crafts.co.uk</p>	<p>GROOVED LIGHTMASTER P5120 (F) C220 11.0KW 1300°C WIRING DIAGRAM 3+N+E (GROOVED KILN)</p>



FIRED UP KILNS

BY:  potterycrafts

Distributed By:

Fired Up Kilns

hello@firedupkilns.com.au
20 Helen Street, Heidelberg West,
Victoria 3081, Australia
www.firedupkilns.com.au
ABN: 365 984 307 89

Fired Up Kilns works from the lands of the Wurundjeri Woi Wurrung and Bunurong peoples of the Kulin Nation and pay our respects to their Elders past and present.

We also acknowledge the Elders, Ancestors, cultures, and heritage of all Aboriginal and Torres Strait Islander Nations.