



ON TARGET
Conversion Sets

AIR-GRAPHICS
CS-07
1/72 SCALE



Limited Edition Resin Conversion Set for the Airfix 1/72 Scale Westland Scout AH.1 model to the Wasp HAS.1 as used by Navies around the world during the 1960's -2000

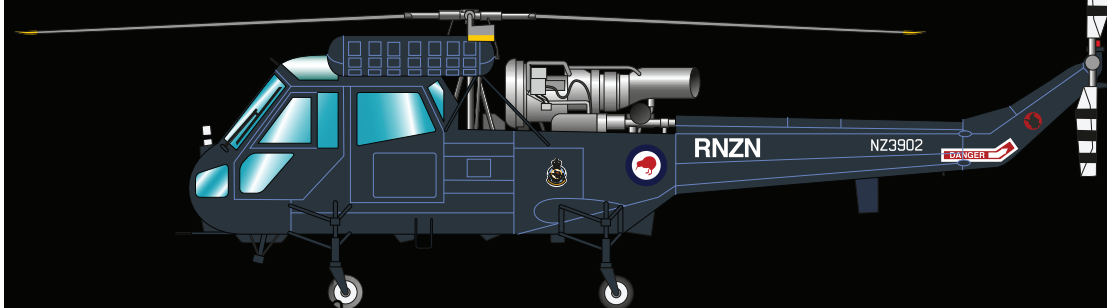

Royal Navy Westland **Wasp** HAS.1

CONVERSION SET

AIR-GRAPHIC MODELS

Westland Scout AH.1 Drawings

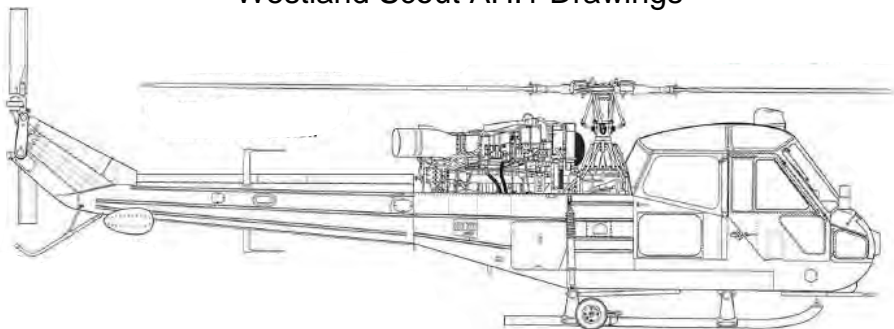

Original shape
of tail rotor



Later style square
tail rotor.

Cut Line

Westland Wasp HAS.1 Drawings

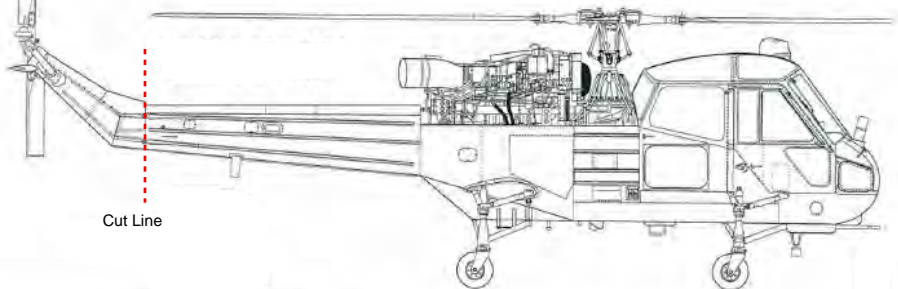

1

Stage 1 - Construct the cabin as per kit and detail as required look at reference material on the web and also we recommend Warpaint No110 Westland Scout & Wasp.

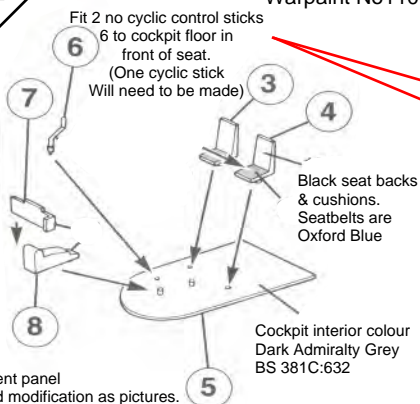

Instrument panel
will need modification as pictures.
Note this is Royal Navy aircraft.
South African and New Zealand Navy
aircraft are slightly different.

4 No Anti-torque pedals
(Made from scratch)
Need to be fitted &
Also new collective levers



Note* Air-Graphics are planning a detailed
Cockpit set for both the Wasp and Scout

2



Remove panel lines shown in red on both sides of fuselage

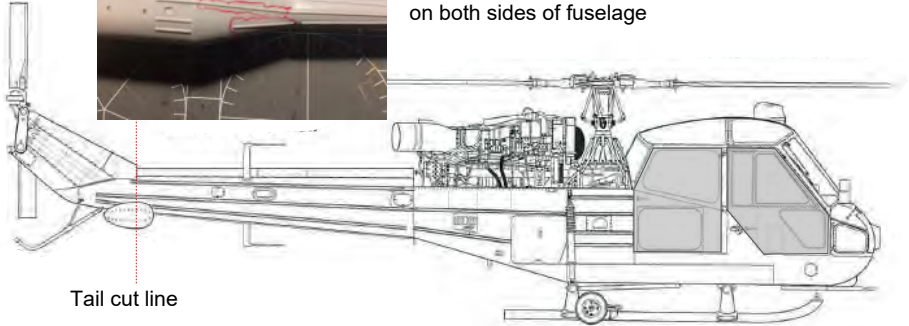

Tail cut line



Wasps were often seen with either the front doors or all four doors removed

Scrap view of doors cut out of fuselage

3



Photos of cabin

If doors are to be open you will need to cut out the small front cabin windows on parts 9 & 10

Don't forget that the cabin roof glazing will need tinting before fixing.
Tint Tamiya X-19 Smoke

Cockpit interior colour
Dark Admiralty Grey
BS 381C:632

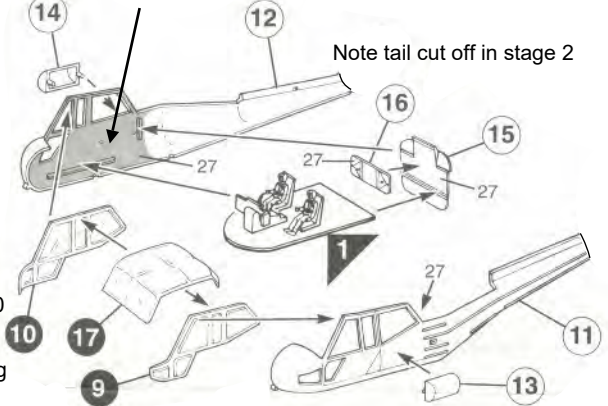

Note tail cut off in stage 2

Fit gun sight at this stage if needed

4

Fit either kit part 18 or replacement resin part if you have the Air-Graphics Wasp engine set AC-180

Note*
Do not fit engine or gear box at this stage

18 Note* tail cut off

Fit resin Part No 1

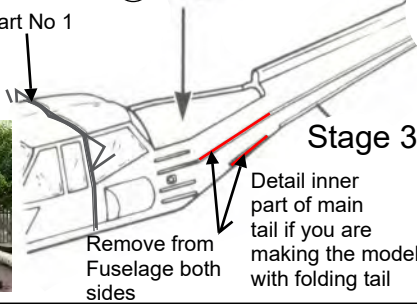

Stage 3

Remove from Fuselage both sides
Detail inner part of main tail if you are making the model with folding tail



5



Fit resin Part 2

Do not fit skirts & fill any location holes

Cut off

Fit rear fuselage housing

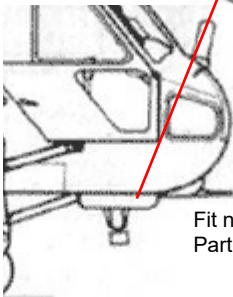

Fit new nose Part No 3 & 4

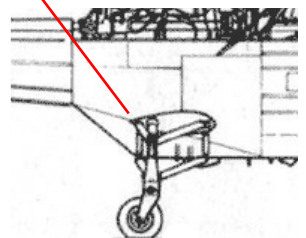

6

Stage 6 - Fixing the undercarriage !

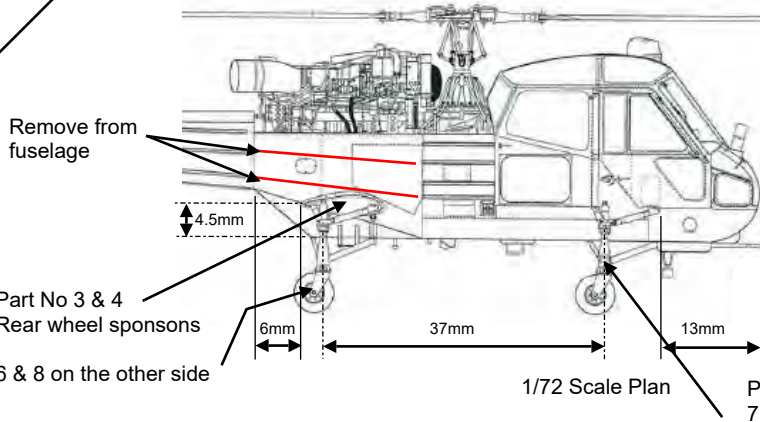

Part no 5 and 7 on the other side
Note part No 16 goes between the under the fuselage between the two undercarriage legs. See Photos'

- Note do not fit wheels at this stage
- Note undercarriage wheel clamps face backwards

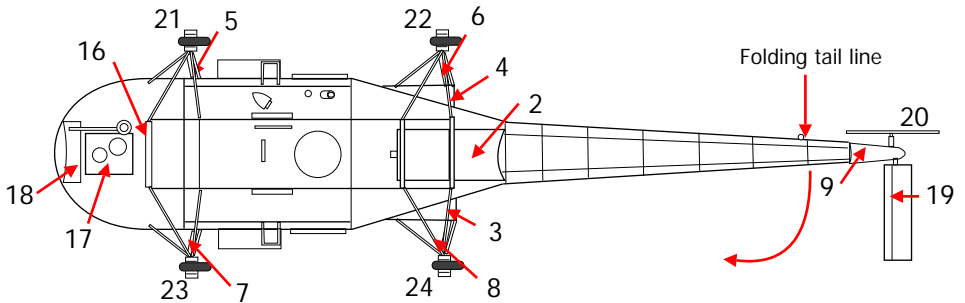

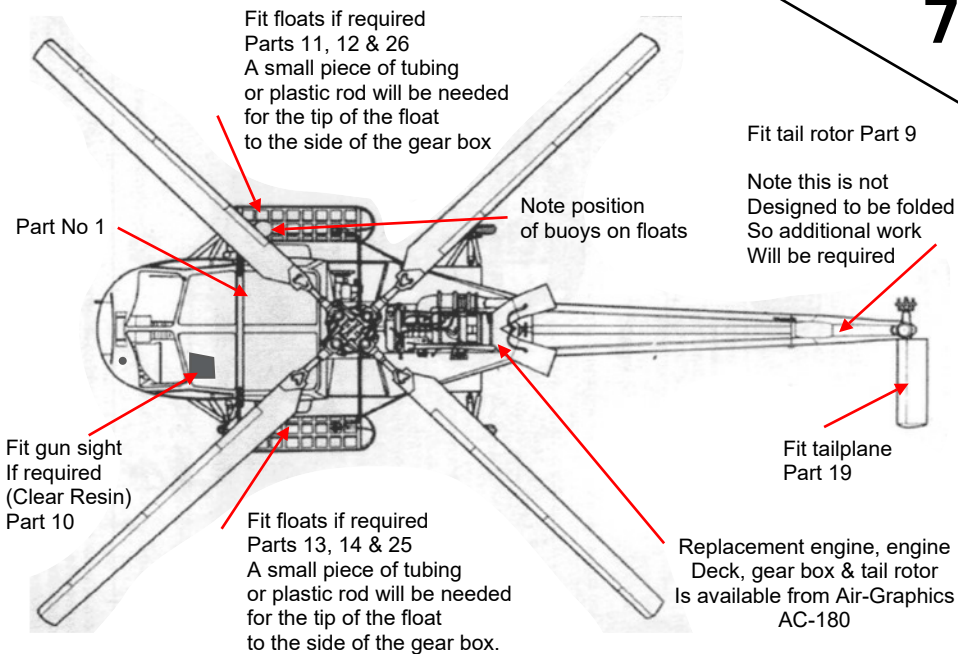

Note, small tubing required
from float to side of the
gearbox



Part 25



Note: Winch and winch arm, note included
In the conversion set



Photo Gallery



Nose improvement bits Including aerials, round cap & thin bar across nose. This also shows the position of the floatation buoys on the floats.



Wasp HAS.1 from HMS Diomedea long after Retirement and before restoration. Good nose And front undercarriage detail



Folding tail details



Good general details including nose and side. Note the gun sight in the roof.



HMS Endurance Falklands War scheme



HMS Endurance standard high-viz scheme

Recommended Accessories:
 AC-133 Wasp NORD SS12 Missile Set
 AC-167 Mk44 Torpedos
 AC-180 Wasp Engine set
 AC-181 Wasp Interior Set
 AC-179 Depth Charges

AIR72-007 Wasp and Scout Decal Sheet

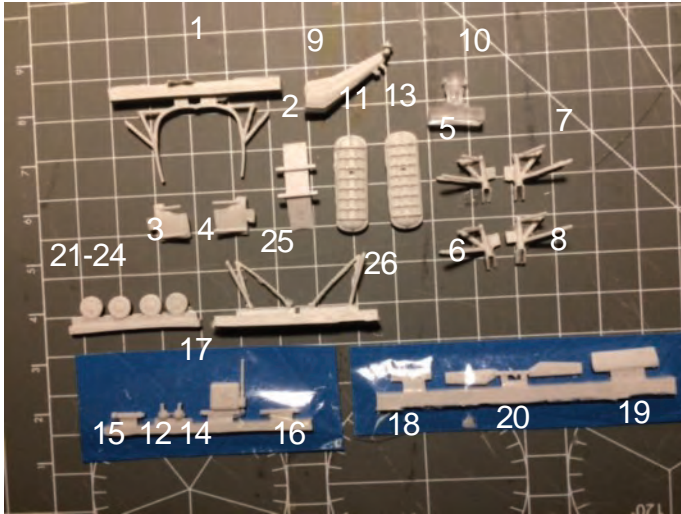

INSTRUCTIONS

- Remove any flash by gently snapping off, or cutting with a scalpel and then lightly sanding.
- Only use Super-glue or a two-part epoxy glue to fix parts.
- Gluing is easier if mating surfaces are slightly sanded to roughen the resin before gluing. Also clean off any dust before gluing.
- Before painting, thoroughly wash all parts in warm water with detergent.
- We recommend the application of a base coat in a light colour to show any blemishes prior to final painting.

WARNING & SAFETY!

- These parts are moulded in polyurethane resin. Please take care when sanding and cleaning up the resin by wearing a dust mask or other protective breathing device to avoid inhalation of the dust particles.
- Wash hands, resin parts and the work surface after sanding resin.
- When using Super-glue or two-part epoxy glue, please take precautions to avoid contact with skin and eyes.
- It is also advisable to wear a mask to avoid breathing in any fumes from the glue or work in a ventilated room.
- The use of barrier creams on hands or wearing disposable gloves, and working in a well ventilated area, is strongly recommended.
- Not suitable to children under 14 years of age.

Thank you for purchasing this Air-Graphics product which forms part of a range of accessories, conversion sets, decals & kits all to 1/72 Scale.

Air-Graphics: 24 Fyfield Close, Wantage, Oxfordshire, OX12 8HN, UK.
 E: sales@air-graphics.co.uk