

# NUTCERTS

## (RIVNUTS)

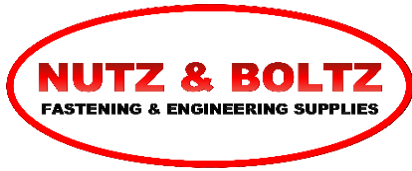

[www.nutzandboltz.com.au](http://www.nutzandboltz.com.au)  
[sales@nutzandboltz.com.au](mailto:sales@nutzandboltz.com.au)  
 07 3812 3925

## Installation Guide

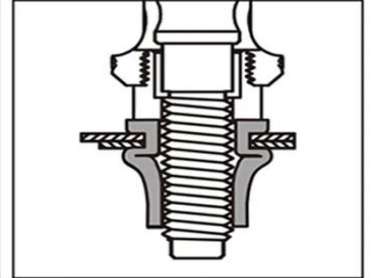
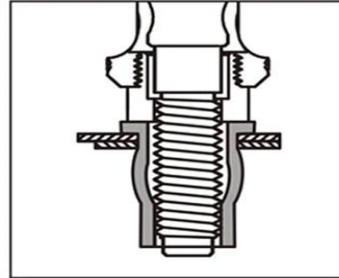
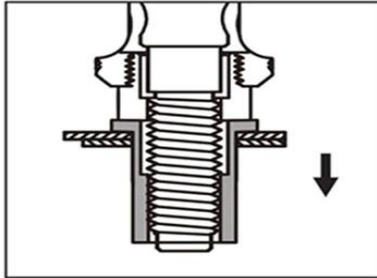
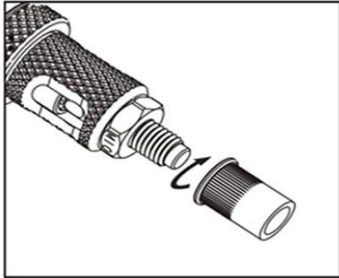

<p><b>1</b> - Wind Rivnut onto end of Tool. Carefully making sure correct Mandrel (Nose Piece) is in the Tool</p>	<p><b>2</b> - Place Nutsert attached to the tool, into the correct pre-drilled hole, ensuring flush contact between bottom flange of Rivnut and face of the hole.</p>	<p><b>3</b> - Gently pull Rivnut tool handles together until pressure becomes quite firm. Over tightening of the Rivnut may result in Tool Damage.</p>	<p><b>4</b> - Once correct installation has been achieved, unwind Rivnut from tool by turning the knob at the opposite end of the threaded part.</p>
---	---	--	--

## Specifications

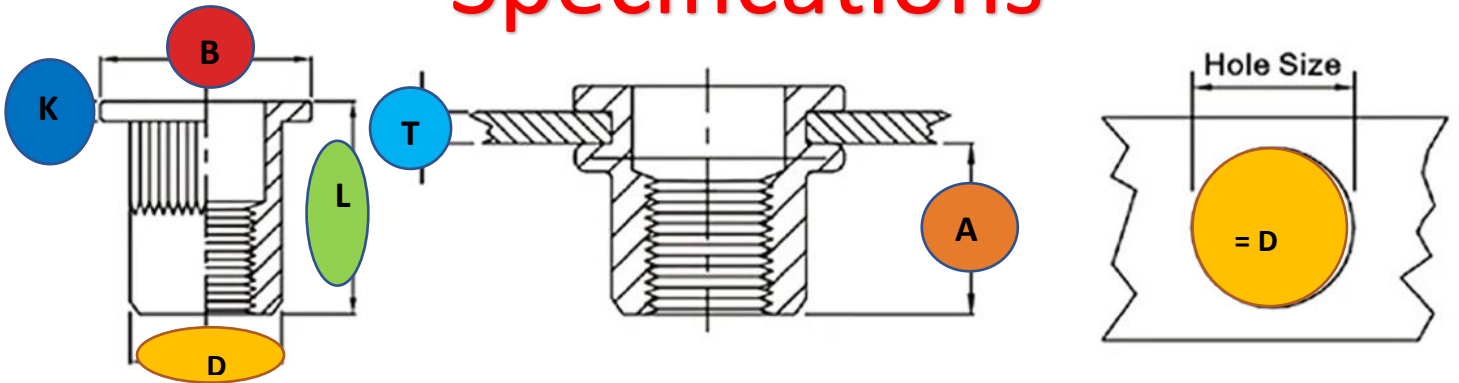

Thread	T (Grip)	Hole Size	A (Varies)	B (Flange)	D (Diameter)	K (Thick)	L (Length)
M3	0.5 - 1.5mm	5 mm	5 mm	7 mm	5 mm	0.8mm	9 mm
M4	0.5 - 2mm	6 mm	6.5 mm	9 mm	6 mm	0.8mm	12 mm
M5	0.5 - 2.5mm	7 mm	8 mm	10 mm	7 mm	1 mm	13 mm
M6	0.5 - 3mm	9 mm	9.2 mm	13 mm	9 mm	1.5 mm	15 mm
M8	1 - 3.5mm	11 mm	11.5 mm	15 mm	11 mm	1.5 mm	18 mm
M10	1 - 3.5mm	13 mm	13.5 mm	17 mm	13 mm	1.7 mm	21 mm
M12	1 - 3.5mm	15 mm	15 mm	19 mm	15 mm	1.8 mm	24 mm
UNC	T (Grip)	Hole Size	A (Varies)	B (Flange)	D (Diameter)	K (Thick)	L (Length)
8-32	0.5 - 2mm	7 mm	7.5 mm	10 mm	7 mm	0.8mm	12 mm
3-16	0.5 - 2.5mm	8 mm	8.5 mm	10 mm	8 mm	1 mm	13 mm
1/4	0.5 - 3mm	10 mm	9 mm	13 mm	10 mm	1.5 mm	15 mm
5/16	1 - 3.5mm	13 mm	10 mm	17 mm	13 mm	1.5 mm	18 mm
3/8	1 - 3.5mm	13 mm	13.5 mm	17 mm	13 mm	1.8 mm	22 mm
1/2	1 - 3.5mm	16 mm	15 mm	22 mm	16 mm	1.8 mm	25 mm