

# InI Assembly Guide

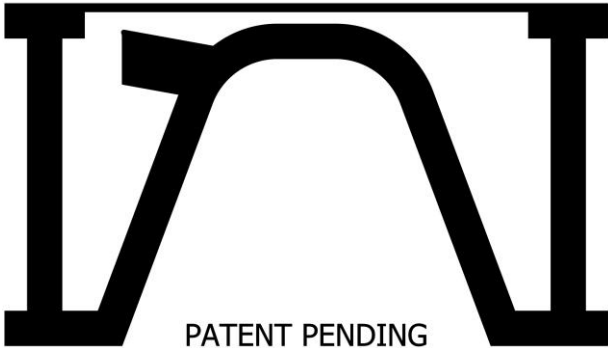
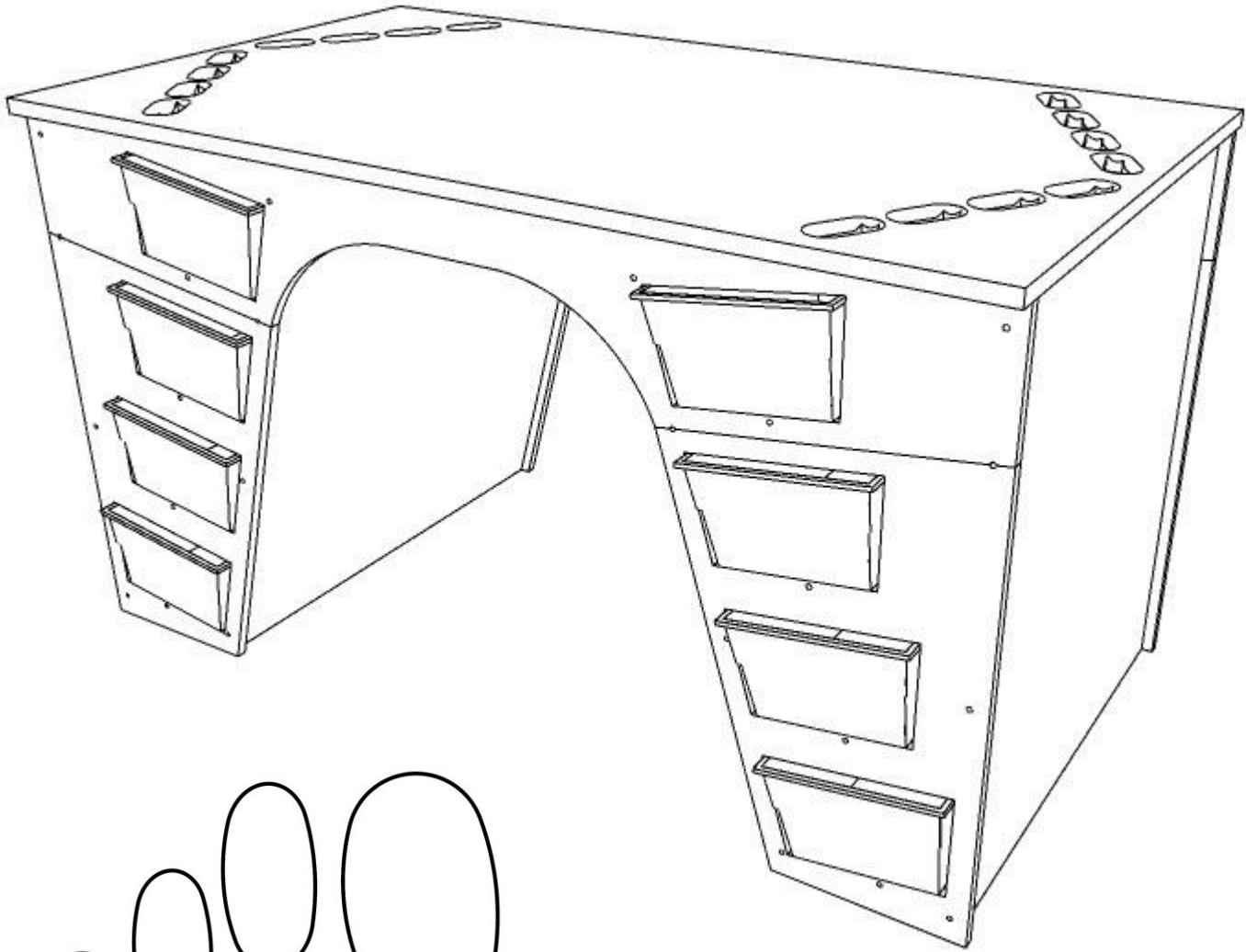

PATENT PENDING

© 2018 Flippytan Furniture

# From the owners of Flippytan Furniture

Thank you for purchasing one of our InI Organization-Playspace Desks. Although we have clients who have purchased the InI to help sort many different items for business and personal use, it was originally designed to tame the large LEGO collections that children acquire slowly over time. An organized LEGO collection is more fun for children to use, as they know where each piece they need should be located. Parents love that their children no longer need to noisily dig through large containers in search of a small piece, or leave most of their LEGO pieces on the floor of the play area.

Your new InI is easy to assemble and intuitive to use. Please take note of the following:

-Flippytan Furniture uses only the highest-quality all-hardwood baltic-birch plywood in the construction of the InI Organization-Playspace Desk. Being a natural wood product, some small discolorations, blemishes, and knots should be expected. These do not alter the functionality of the desk.

-Some desks are fully assembled and disassembled after manufacture to ensure we continue to meet our high quality standards.

-Although we appreciate when our clients assemble our desks in a manner which displays our logo on one of the outward-facing panels, the panel bearing our logo may also be installed on the interior portion of the desk. Aside from the Flippytan logo, all four of the included side panels are the same.

-The InI Organization-Playspace Desk is designed to comfortably accommodate a typical folding-chair in the chair opening while sorting. Most clients prefer to be seated while sorting. For those who prefer to stand or use a taller chair, the desk may be elevated by placing solid, sturdy spacer blocks under each side. Please keep safety in mind when choosing spacers, and keep the desktop level.

Thanks again, and enjoy your new InI!

Don and Kiyoko DuLac

# Large box contains the following items:

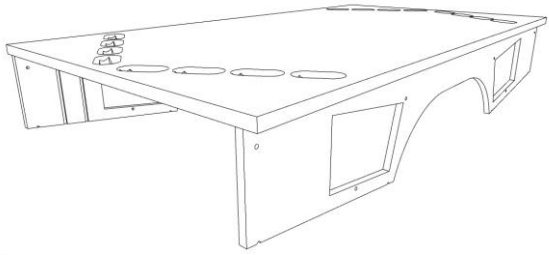

Top with attached hinged faces (1)



Side Panel (4)

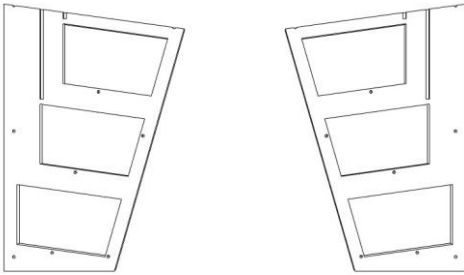

Left Face (2) and Right Face (2)



Short Baffle (2)

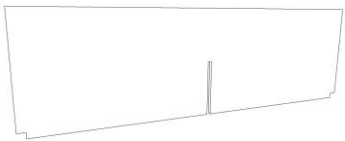

Medium Baffle (2)

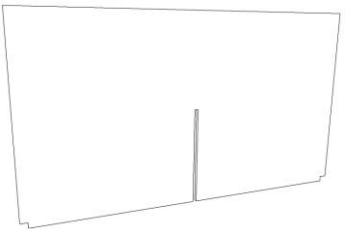

Tall Baffle (2)

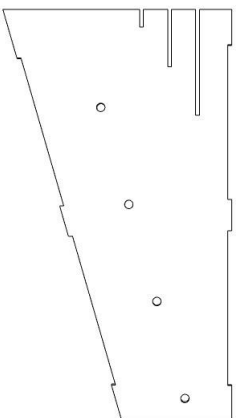

Center Baffle (2)

# Large box contains the following items:

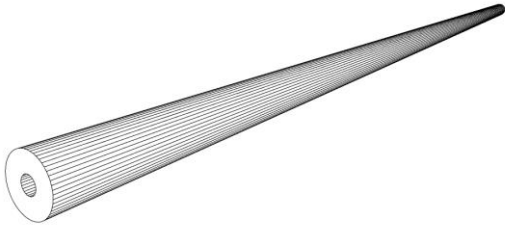

Tray Support Dowel (8)

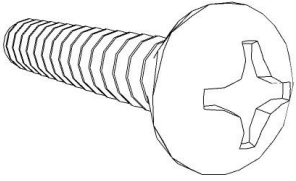

Screw (48)

# Small box contains the following items:

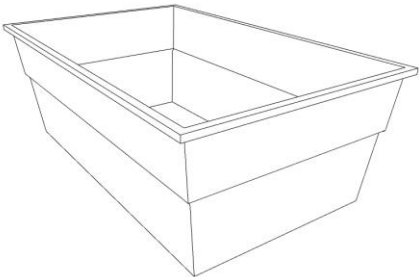

Bin (16)

# Assembly Steps

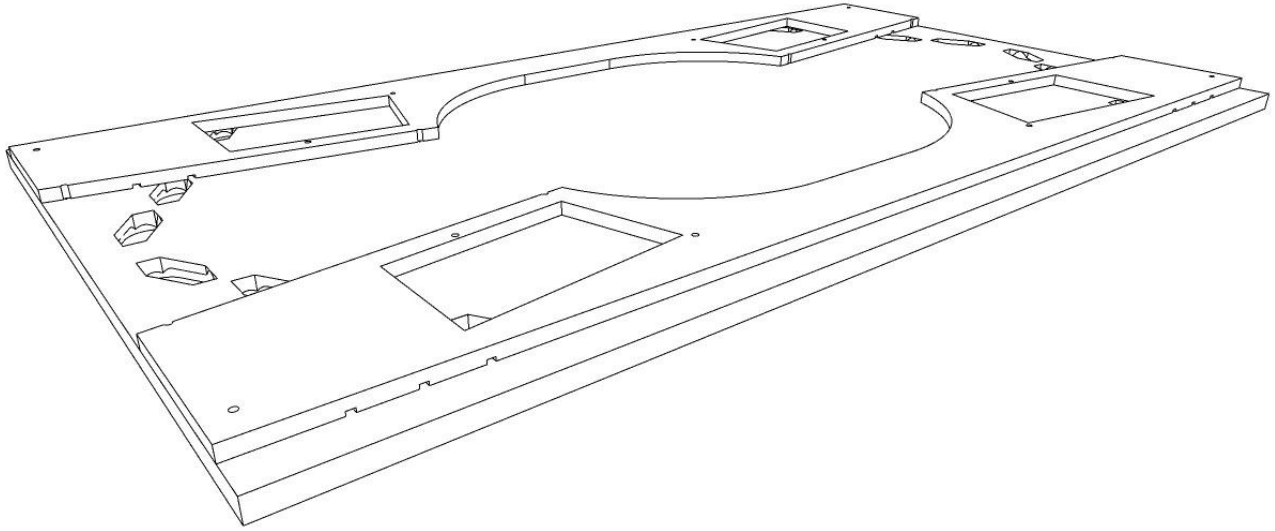

**Step 1: Lay InI top face-down on carpeted surface.**

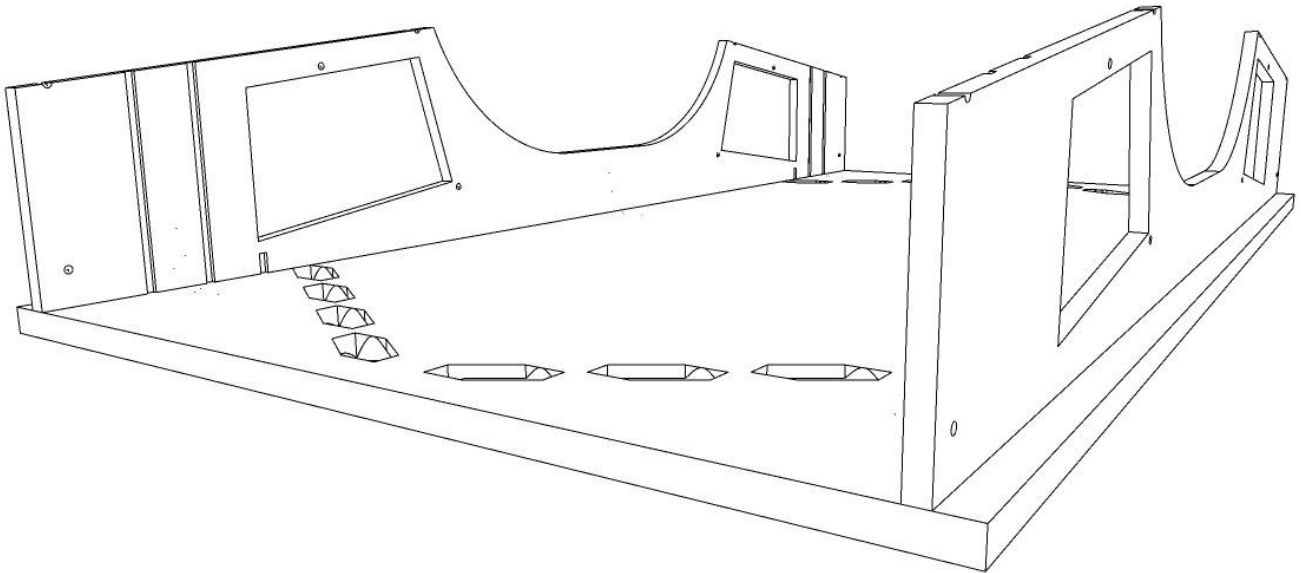

**Step 2: Rotate the hinged faces upright.**

# Assembly Steps

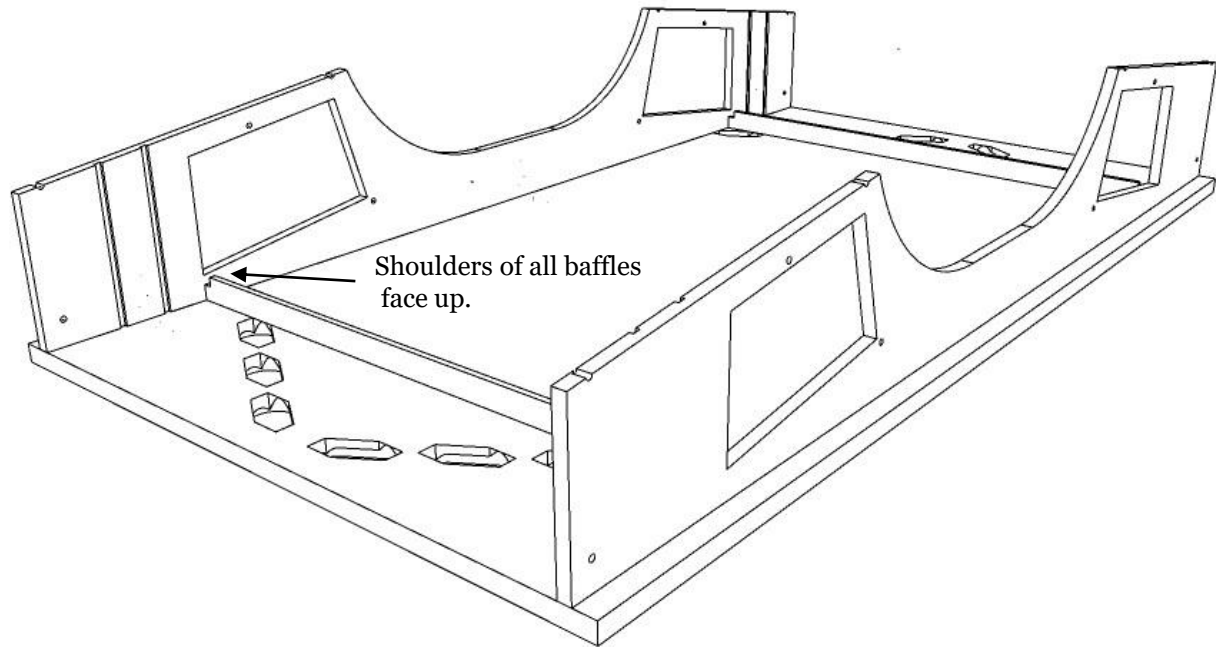

Step 3: Insert short baffles into slots in hinged faces.

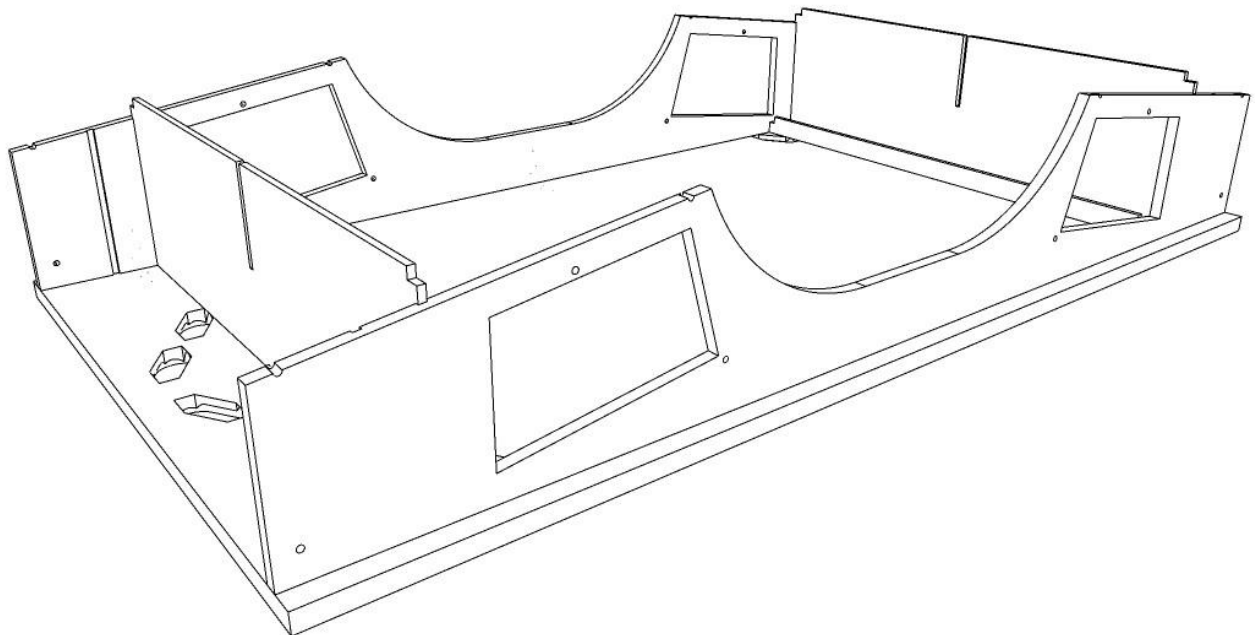

Step 4: Insert medium baffles into middle slots in hinged faces.

# Assembly Steps

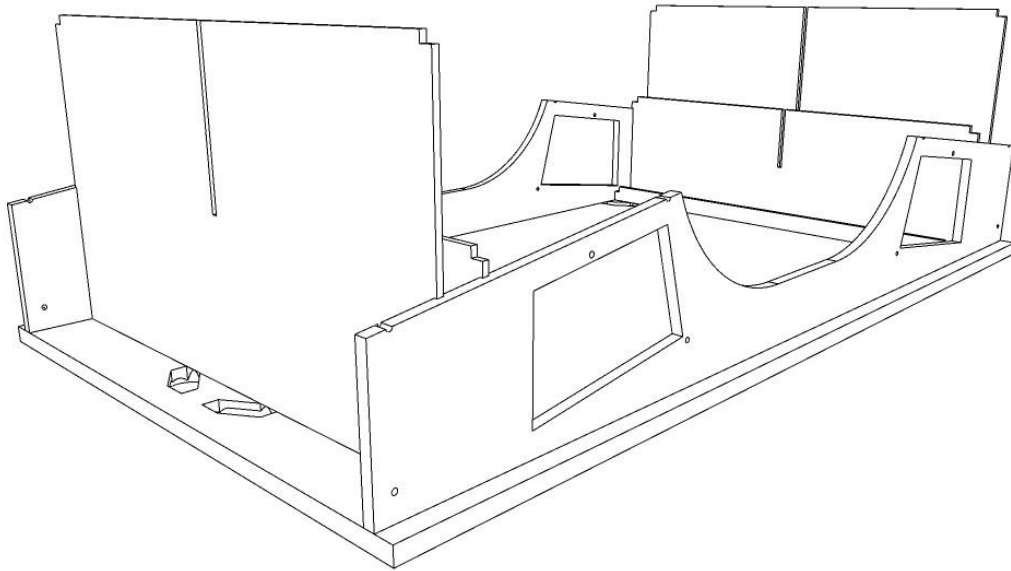

Step 5: Insert tall baffles into outermost slots in hinged faces.

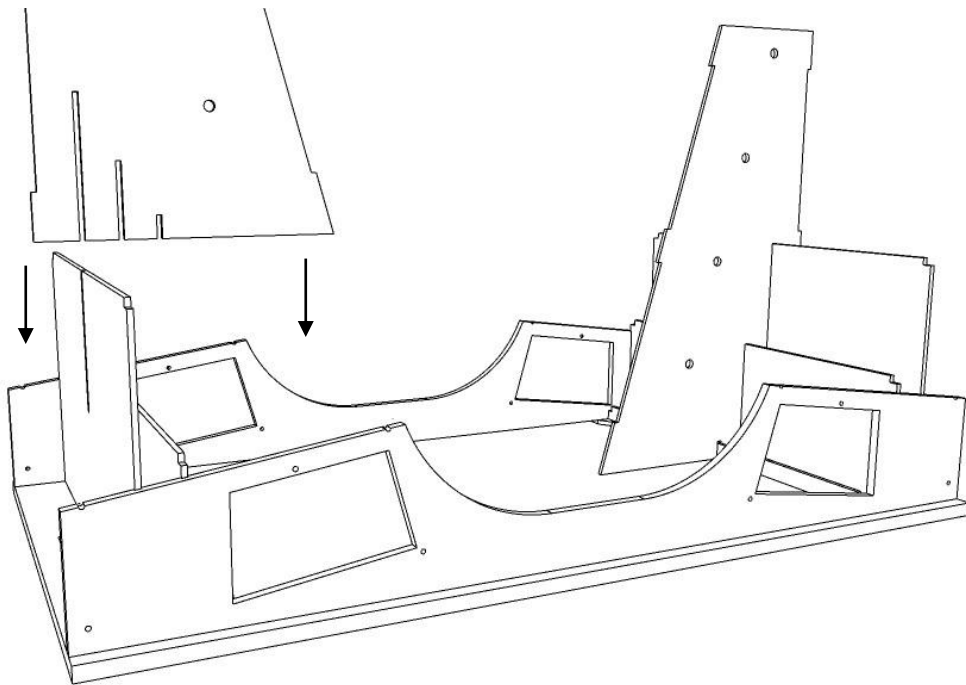

Step 6: Insert center baffles into baffle group as shown.

# Assembly Steps

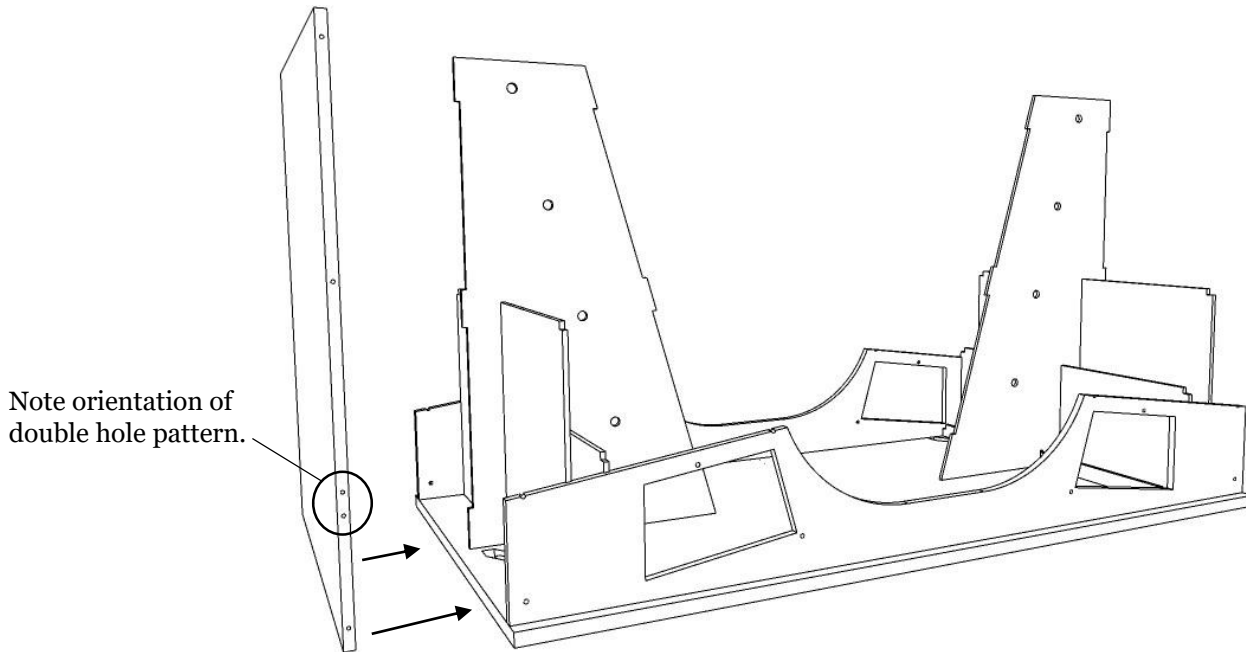

**Step 7: Install outermost panels, ensuring that double-hole pattern is facing downward.**

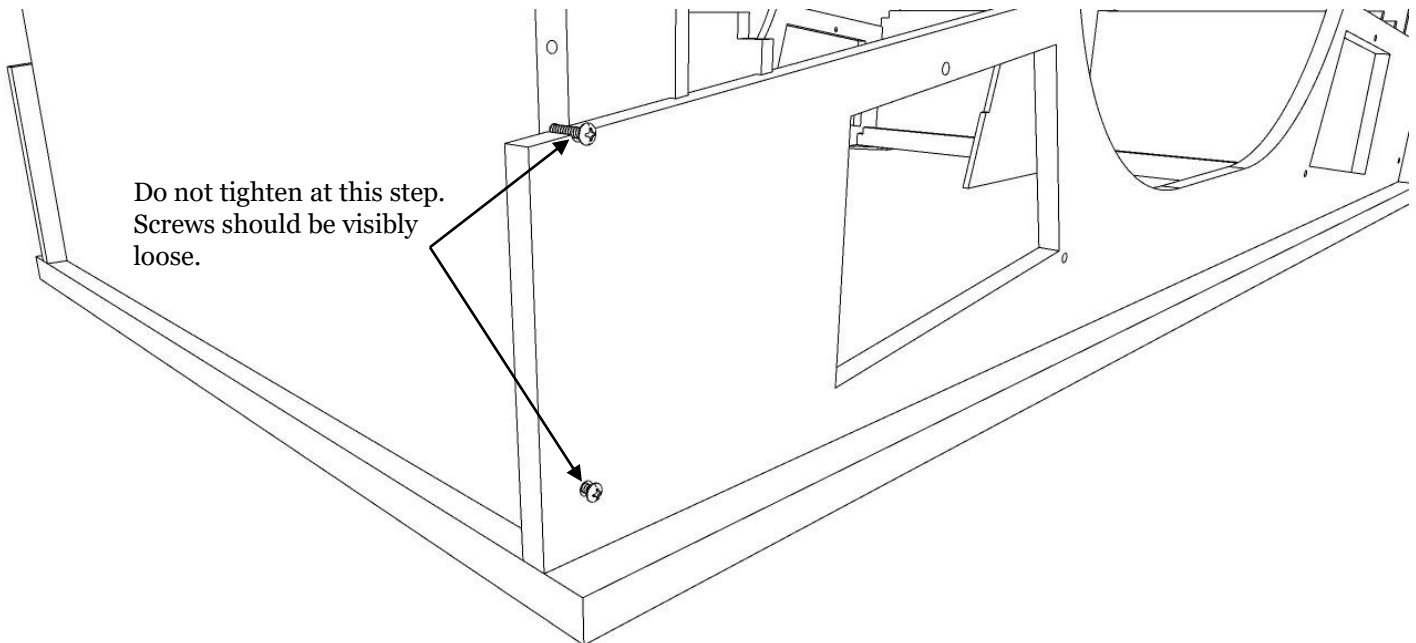

**Step 8: Loosely set the two lower screws through the hinged face into the side of the panel.**



# Assembly Steps

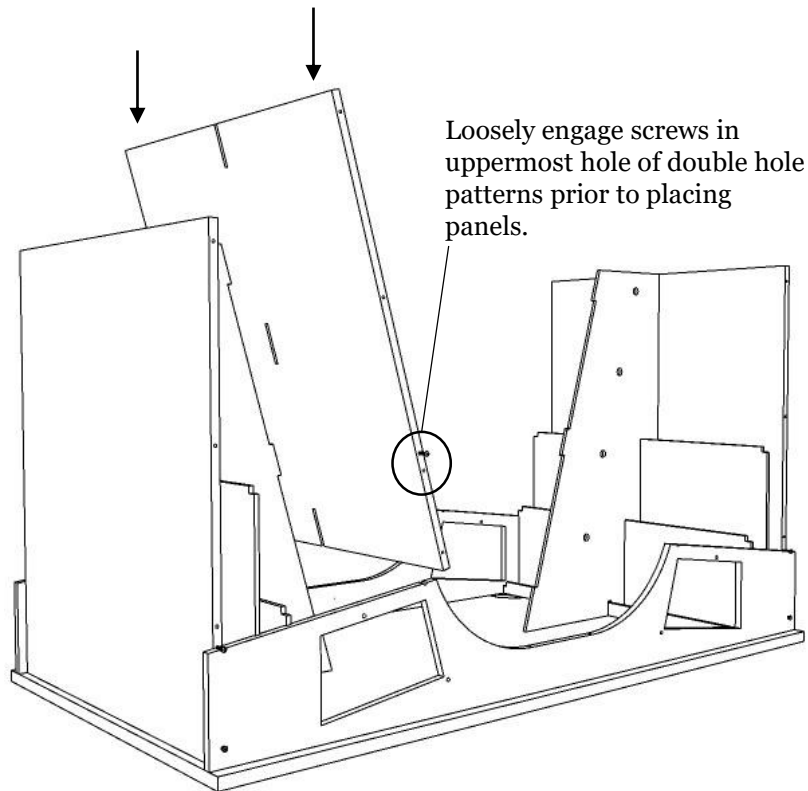

Step 9: With screws loosely engaged in uppermost hole of double hole pattern, insert inner panels into place. Ensure that center baffle tabs fully engage with slots in panel.

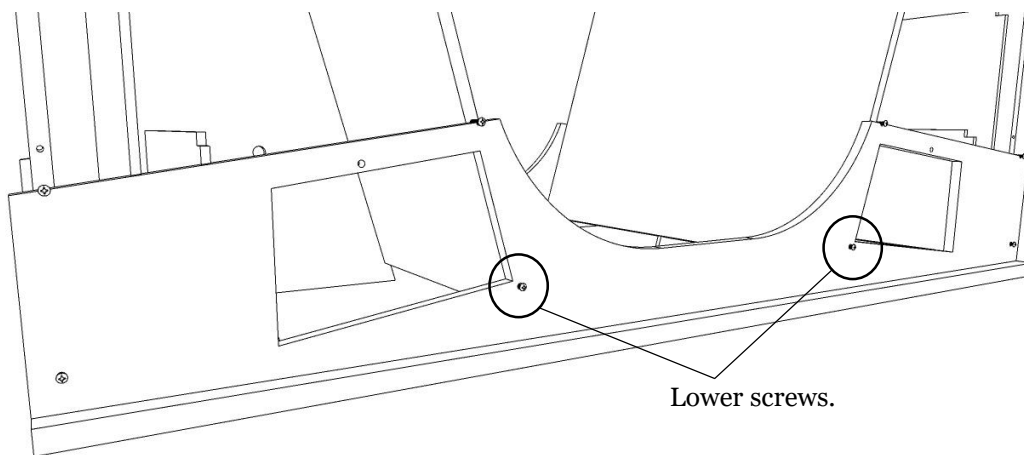

Step 10: Loosely install lower screws.

# Assembly Steps

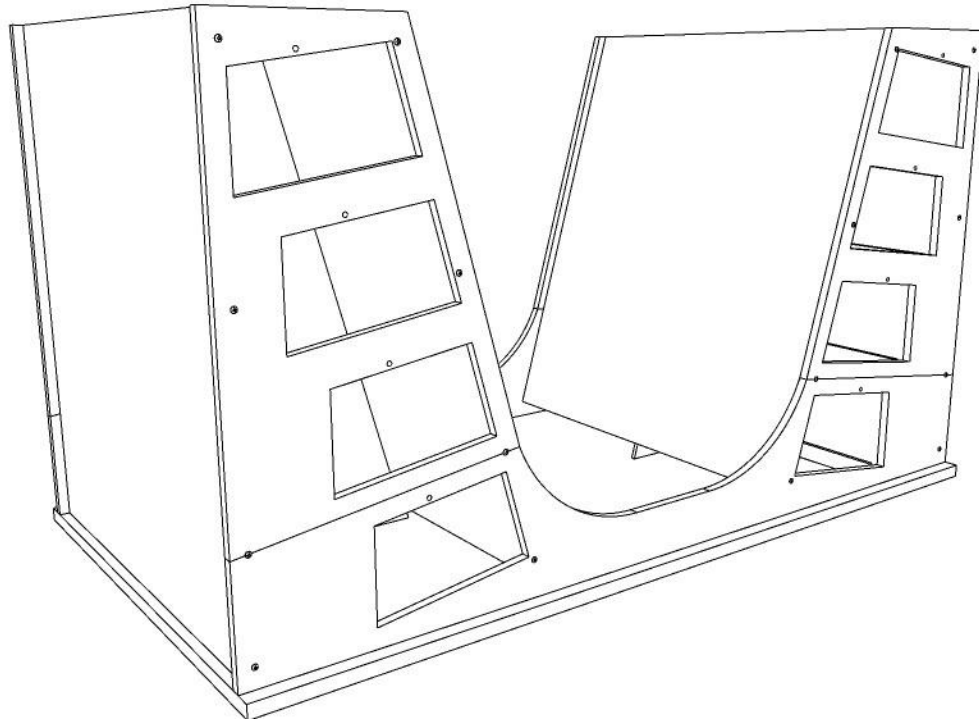

Tip:  
Do not over-tighten screws.  
This will damage the finish.

**Step 11:** Place left and right faces into position and secure with screws. Tighten all screws, including previously installed screws.

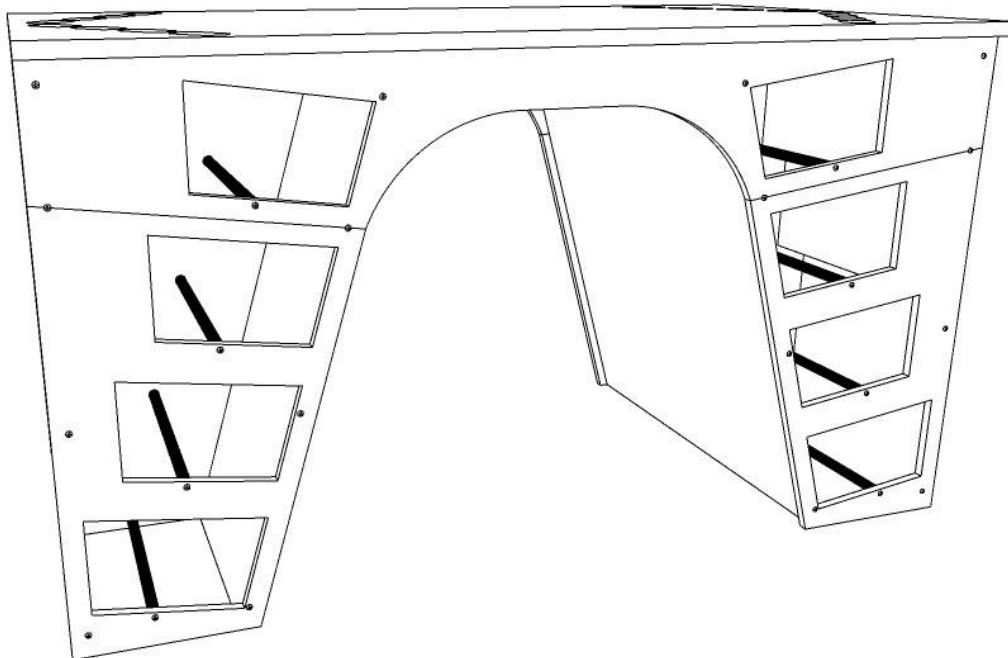

**Step 12:** Flip InI upright. Push tray support dowels through corresponding holes in center baffles. Install and tighten screws into dowel ends.

# Assembly Steps

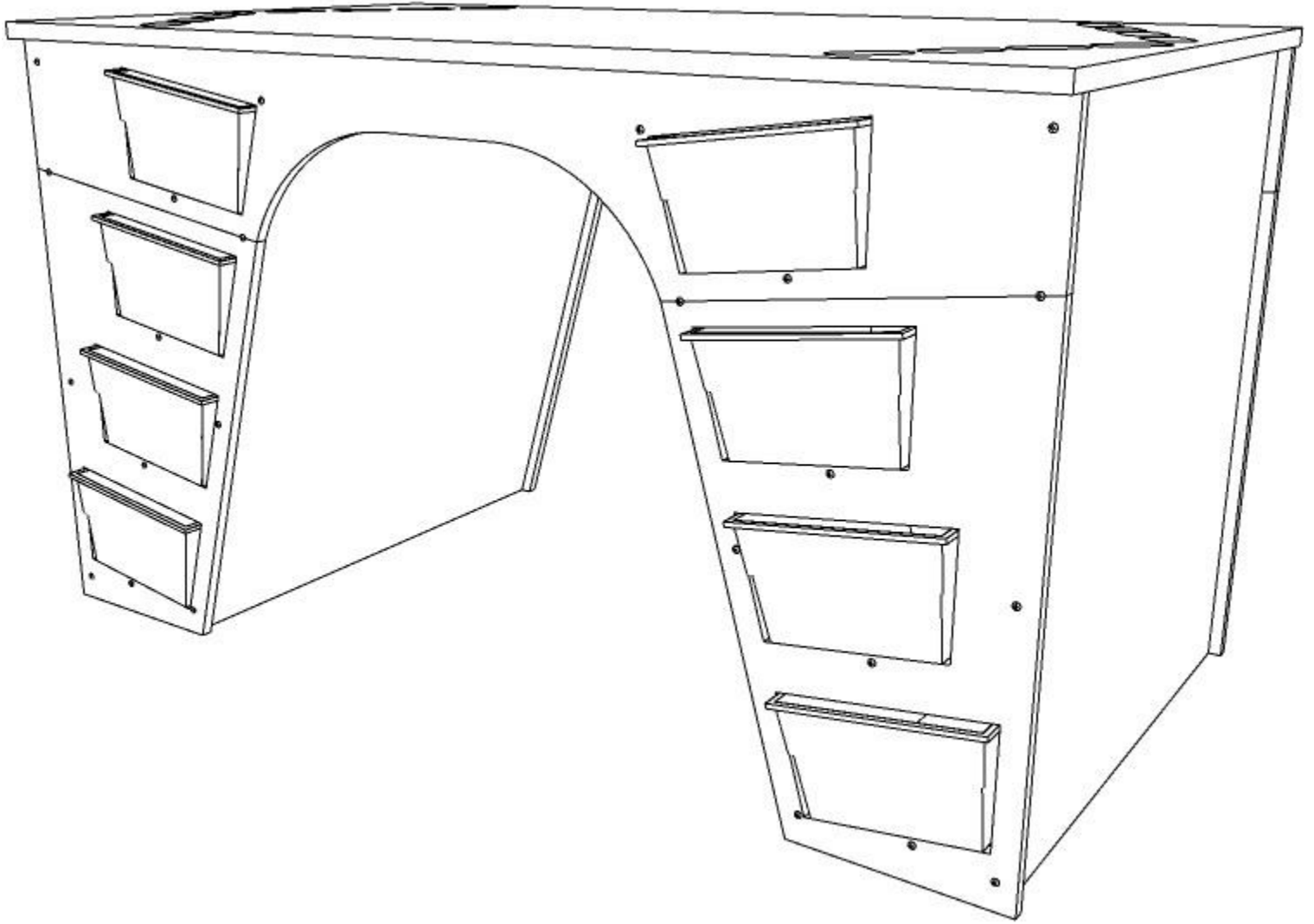

Step 13: Insert plastic trays fully into openings. Your InI is now completely assembled. We recommend labeling the sorting slots in the top with removable labels to assist with sorting.