

SHERCO

MANUEL D'ATELIER | WORKSHOP MANUAL | MANUAL DE TALLER

450 SEF-R

500 SEF-R

450 SEF FACTORY

500 SEF FACTORY



AN EMOTION IS BORN

SUMMARY

FOREWORD	4
TOOLSLISTFOR450SEF-ENGINE	5
TECHNICALSPECIFICATIONS	6
) Engine	6
) Chassis.....	7
FACTORYSETTINGS	8
) Fork.....	8
) Shock absorber	9
OPERATIONSREQUIRINGTHEREMOVAL,ORNOT,OFTHEENGINE	10
REMOVING/INSTALLINGTHEENGINE	11
) Removing the engine	11
) Installing the engine in the frame.....	12
REMOVINGTHEENGINE	13
) Preparation	13
) Removing the cylinder head cover	13
) Set the engine at top dead center.....	13
) Removing the camshafts	14
) Removing the distribution tensioner	14
) Removing the drive chain	14
) Removing the cylinder head	15
) Removing the cylinder	15
) Removing the piston	15
) Removing the ignition cover	15
) Changing the stator and the engine speed sensor.....	16
) Removing the rotor.....	16
) Removing the drive chain	16
) Removing the electric starter	16
) Removing the clutch	17
) Removing the water pump housing	17
) Removing the clutch housing	17
) Removing the water pump oil seal and the bearing	18
) Removing the clutch bellhousing.....	18
) Removing the freewheel sprocket	19
) Removing the oil pump	19
) Changing the oil pump	19
) Removing the index shim.....	19
) Separating the central crankcases	20
) Removing the gearbox.....	20
) Removing the crankshaft	20
CHECKINGINDIVIDUALPARTS	21
) Controlling the central crankcases	21
) Left crankcase.....	21
) Right crankcase	21
) Checking the freewheel sprocket bearing	22

) Changing the crankshaft bearings	22
) Checking the crankshaft	23
) Checking the gearbox	24
) Checking the clutch	24
) Checking the top-engine	25
) Checking the cylinder head	28
) Checking the distribution	28
ENGINEASSEMBLY	29
) Installing the central crankcases	29
) Installing the clutch housing	31
) Installing the water pump housing	31
) Installing the clutch	32
) Installing the electric starter	32
) Setting the piston rings	33
) Installing the piston	33
) Installing the cylinder	34
) Installing the cylinder head	34
) Installing the drive chain	35
) Installing the rotor	35
) Installing the camshafts and setting the valve timing	36
) Checking the valve clearance	36
) Completing the engine assembly	37
) Installing the ignition cover	37
TIGHTENINGTORQUECHART	38
CLEANINGTHEHOTTLEBODY	40
) Equipment	40
) Removing the throttle body	40
) Cleaning the throttle body	42
) Installing the throttle body	42
CHANGINGTHETPS-THROTTLEPOSITIONSENSOR	43
INJECTIONDIAGNOSTICTOOLS SYNERJECT	44
) 1- Presentation of the SYNERJECT injection system	44
) 2- Software overview	50
) 2.1 Connection with Keyless system	50
) 2.2 Software settings : configuration menu	52
) 2.3 Update menu and synchronization	53
) 3- Using the software	55
CHECKINGTHECHARGINGCIRCUIT	68
CONTROLOFTHESENSORS	70
) 1- Control of the TPS sensor	70
) 2- Values of temperature sensor	71
WIRINGDIAGRAM	72
Injection wiring harness	72
Light wiring harness 450 SEF	75
Light wiring harness Racing 450 SEF-R	76
Accessories wiring harness	77
Fan wiring harness	78

FOREWORD

This manual is intended for qualified mechanics working in a properly equipped workshop. Performing the different operations requires sound knowledge of mechanics and SHERCO tools specific to 450/500 SEF engines.

TOOLS LIST FOR 450/500 SEF ENGINE

» 450/500 SEF

Tool reference	Description
1819	Top dead center timing screw
5749	Clutch removal tool ADLER
4753	Fret-type ignition unit
1822	Water pump bearing axis tool
1968	Water pump oil seal tool
R455	Engine support
5593	Primary drive locking tool
5774	Piston support
R462	Flywheel puller
R464	Crankshaft ring extractor
R450	Oil seal selector
R472	Applying tool for oil seal selector
5773	Special 450 spark plug wrench
5028	PUSH-IN TOOL Ø48
4967	Synerject injection diagnostic tool
5132	Adjustable hook spanner wrench WP Ø48
5029	Joint guide tool WP Ø48
5030	Bottle-type leveling tool WP
5031	Pipe vise clamp WP 48/60
R453	Selector shaft bearing assembly tool
R444	Oil seal selector
6267	Shunt for Keyless system

TECHNICAL SPECIFICATIONS

» Engine

Type	Single cylinder 4 stroke liquid cooled	
Displacement	449.4 cc	478.222 cc
Bore / Stroke	95X63.9 mm	98X63.4 mm
Compression ratio	11.84 : 1	11.44 : 1
Unleaded	gasoline with an octane rating of at least 95	
Distribution	4-valve, double overhead camshaft, chain drive	
Intake valve diameter	38mm	
Exhaust valve diameter	30.5	
Intake valve cold clearance	0.15-0.2mm	
Exhaust valve cold clearance	0.2-0.25mm	
Crankshaft bearings	2 roller bearings	
Piston	forged aluminum	
Lubrication	Full pressure lubrication with 2 trochoid pumps	
Motor oil	1 liter SAE 10w60	
Primary drive	25 : 75	
Gearbox :	6 speed	
1 st	13 : 32	
2 nd	16 : 29	
3 rd	19 : 27	
4 th	21 : 24	
5 th	23 : 22	
6 th	25 : 21	
Final drive	14 X 49	
Clutch	multi disc clutch in oil bath, hydraulically operated	
Start-up/battery	Electric 12V 4Ah / LTZ5S Lithium 12V 2Ah	
Electronic injection	Synerject	

TECHNICAL SPECIFICATIONS

» Chassis

Frame	Semi-perimeter Cr Mo steel with aluminum subframe
Fork	KAYABA USDclosed cartridge Ø 48mm (Factory) WP Xplor suspension USD Ø 48mm Racing)
Rear suspension	KAYABA suspension with sparate cylinder WP suspension with sparate cylinder
Travel front/rear	FACTORY 330/330 mm RACING 300/330 mm
Front brake	Disc Ø 260mm (Factory/Racing)
Rear brake	Disc Ø 220mm (Factory/Racing)
Disc brakes	Wear limit : 2.7mm front and 3.6mm rear
Front tire	90/90-21"
Rear tire	140/80-18"
Pressure off-road front/rear	0.9 bar
Fuel tank capacity	9.7l with 1 liter of reserve
Steering angle	27.3°
Wheelbase	1490mm
Weight	110 kg

FACTORY SETTINGS

» Fork

Original settings – Fork KAYABA USD Ø48 mm

Compression	Comfort	20 clicks back
	Standard	12 clicks back
	Sport	8 clicks back
Rebound	Comfort	18 clicks back
	Standard	12 clicks back
	Sport	10 clicks back
Spring stiffness	Rider weight : 65-75 kg	4.2N/mm
	Rider weight : 75-85 kg	4.4N/mm (original)
	Rider weight : 85-95 kg	4.6N/mm
Type of oil/ Quantity of oil	01M	345cc

Original settings – Fork WP XPLOR suspension USD Ø48mm

Compression	Comfort	18 clicks back
	Standard	15 clicks back
	Sport	12 clicks back
Rebound	Comfort	18 clicks back
	Standard	15 clicks back
	Sport	12 clicks back
Preload	Comfort	+0 turn
	Standard	+0 turn
	Sport	+6 turns
Spring stiffness	Rider weight : 65-75 kg	4.2N/m
	Rider weight : 75-85kg	4.4N/mm (original)
	Rider weight : 85-95kg	4.6N/m
Type of oil	SAE 4	
Springs Length with preload spacer	474 mm	
Quantity of oil	606 ml	
Oil level measurement (fork compressed and spring removed) from the top of the fork tube	110mm (mi 30 – max 120 mm)	

FACTORY SETTINGS

Shock absorber

Racing Settings –KAYABA shock absorber

Low-speed compression	Comfort	20 clicks back
	Standard	14 clicks back
	Sport	12 clicks back
High-speed compression	Comfort	2.5 turns back
	Standard	1.5 turns back
	Sport	1 turn back
Rebound	Comfort	15 clicks back
	Standard	13 clicks back
	Sport	11 clicks back
Spring stiffness	Rider weight : 65-75 kg	48N/mm
	Rider weight : 75-85 kg	50N/mm (original)
	Rider weight : 85-95 kg	57N/mm
Type of oil		K2c

Racing Settings – WP suspension shock absorber

Low-speed compression	Comfort	17 clicks back
	Standard	12 clicks back
	Sport	9 clicks back
High-speed compression	Comfort	2 turns back
	Standard	1.5 turns back
	Sport	1 turn back
Rebound	Comfort	16 clicks back
	Standard	14 clicks back
	Sport	12 clicks back
Spring stiffness	Rider weight : 65-75 kg	51N/mm
	Rider weight : 75-85 kg	54N/mm (original)
	Rider weight : 85-95 kg	57N/mm

OPERATIONS REQUIRING THE REMOVAL, OR NOT, OF THE ENGINE

	Opération requiring the removal of the engine	Opération not requiring the removal of the engine
Crankshaft (including crankshaft repair kit)	•	
Complete transmission	•	
Crankshaft bearing	•	
Gearbox bearing	•	
Piston	•	
Cylinder	•	
Cylinder head	•	
Distribution		•
Ignition		•
Starter gears		•
Freewheel		•
Complete clutch		•
Water pump		•
Oil pump		•
Gear selector set		•

REMOVING/INSTALLING THE ENGINE

» Removing the engine

WARNING

To remove the engine, remove the swing arm pivot axis, which allows you to remove the whole rear wheel / swing arm set. In order to prevent the bike from tipping over, hold the frame using a jack.

- Empty (see the User Manual)
 - The engine oil
 - The coolant.
- Place the motorcycle on a stool.
- Remove the saddle.
- Disconnect the battery (see usermanual).
- Remove the tank along with its vents (refer to the user manual).
- Disconnect the entire harness connected to the engine (starter case, TPS, water temperature sensor, pencil coil and injector).
- Remove the springs of the exhaust pipe in order to remove it.
- Remove the pencil coil.
- Remove the throttle body.
- Remove the chain guard.
- Remove the secondary transmission line (quick release).
- Remove the clutch receiver.

WARNING

When the clutch receiver is removed, the piston is no longer supported. Hold the piston with a plastic clamp.

- Remove the water radiator hoses connected to the engine.
- Remove the left radiator.
- Remove the cylinder head frame mounting brackets.
- Remove the frame guards on both the right and left sides of the bike.
- Unscrew the swing arm pivot.
- Loosen the other two engine axes.
- Unscrew the swing arm pivot and pull the swing arm slightly backward.
- Remove the engine axes.
- Remove the engine through the left side by pivoting it.

NOTE :

Vous devriez avoir une aide extérieure pour cette étape, le poids étant conséquent. Assurez-vous de ne pas endommager les pattes de fixation moteur sur le cadre.

REMOVING/INSTALLING THE ENGINE

» Installing the engine in the frame

- Position the motor within the frame.
- Position the swing arm.
- Set the engine axes.
- **Tighten the motor axes to 40 Nm.**
- **Tighten the swing arm pivot to 100 Nm.**
- Set the frame guards and secure them with clamps.
- Put the right and left cylinder head supports. **Put red thread lock and tighten to 25 Nm.**
- Fit the left radiator and tighten to 10 Nm.
- Place the cooling hoses
- Make sure the engine is clean and place back the clutch receiver. **Tighten to 10 Nm.**
- Place the secondary chain and adjust the tension (see procedure on the user manual).
- Put the chain guard.
- Put the throttle body.
- Put the pencil coil.
- Put the exhaust pipe and secure it to the cylinder with its two springs.
- Reconnect the entire harness connected to the engine (starter case, TPS, water temperature sensor, pencil coil and injector).
- Reinstall the tank along with its vents (refer to the user manual).
- Reconnect the battery (refer to the user manual).

WARNING

Before reconnecting, check that the ignition key/ the is in the «OFF» position.

- Place back the saddle.
- Fill coolant and engine oil (refer to the user manual).

REMOVING THE ENGINE

» Preparation

- Place the engine on the R455 engine support tool.
- Drain the engine oil (see user manual).
- Make sure to be in a clean environment before starting the dismantling of the engine.
- Remove the output shaft pinion.

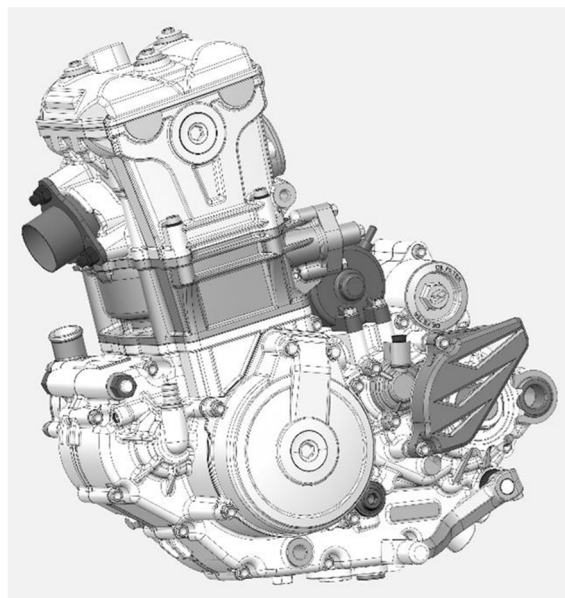

» Removing the cylinder head cover

- Remove the spark plug with the special spark plug tool 5773.
- Unscrew the 3 screws (1) and remove the cylinder head cover.

WARNING

The screws have an o-ring.

- Remove the cylinder head cover gasket.

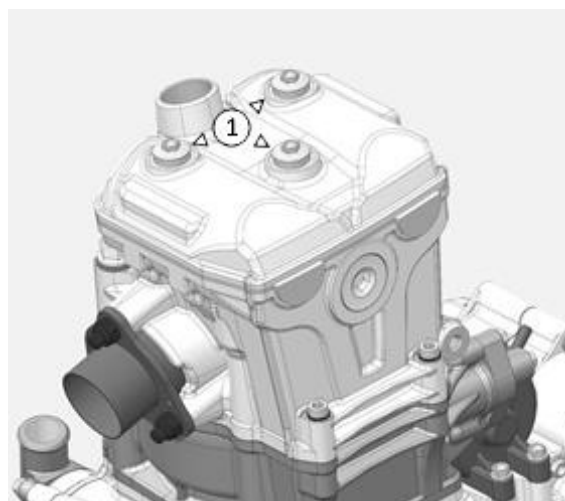

» Set the engine at top dead center

- Remove the ignition cover plug (1).
- Remove the timing control plug (2).
- Rotate the motor counterclockwise in order to align the center of the hole of the crankshaft with that of the crankshaft timing control, set the top dead center timing tool on (2) (Ref. 1819).

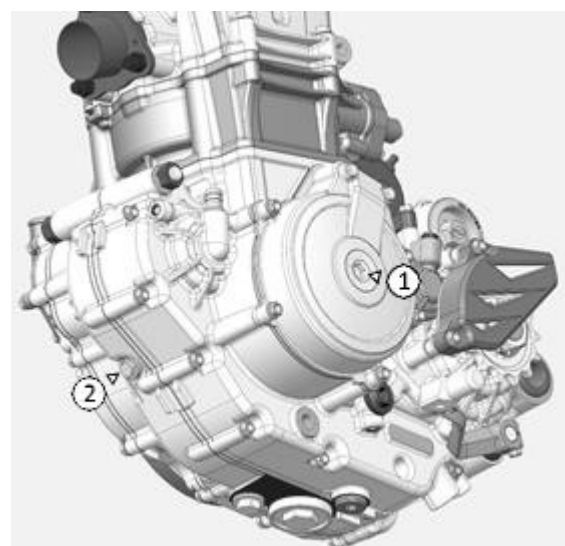

REMOVING THE ENGINE

» Removing the camshafts

- Unscrew the eight screws from the shaft bearing cap cam following the order shown in the picture.
- Remove the bearing cap (A).
- Remove the camshafts.

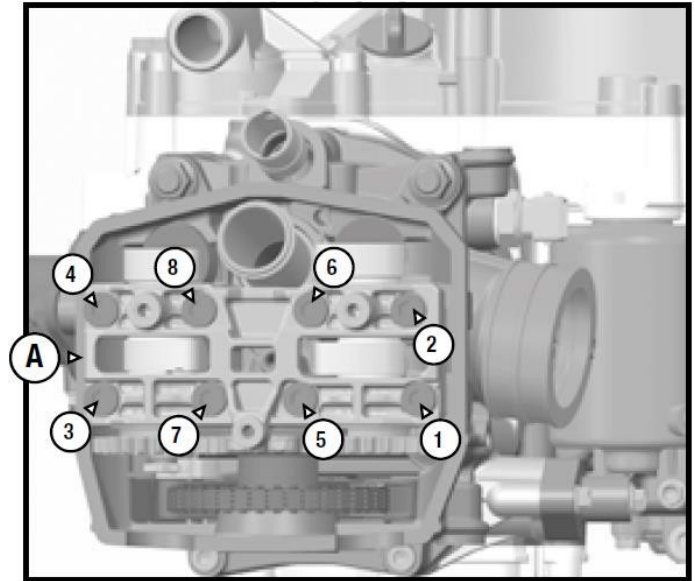

» Removing the distribution tensioner

- Unscrew the screw (1) and remove the spring.
- Unscrew the two screws (2).
- Remove the tensioner along with its gasket.

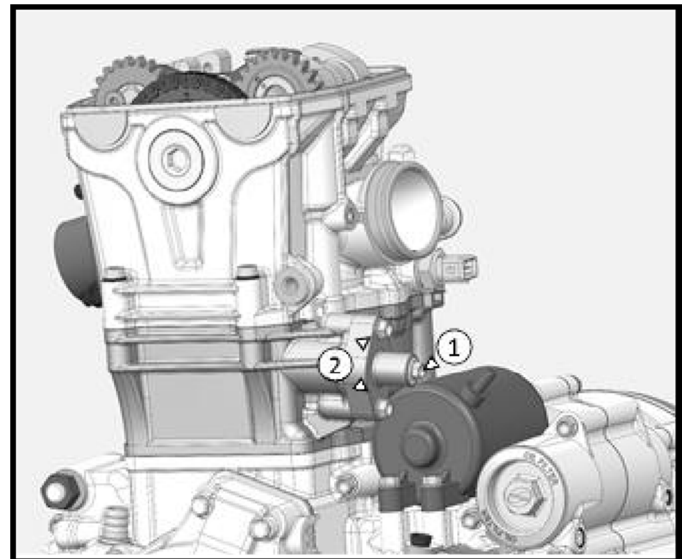

» Removing the drive chain

- Remove the cap (1) and then the shaft (2).
- Hold the pinion (3) and disengage the chain.
- Remove the pinion (3).
- Remove the timing tool from the top dead center position 1819.

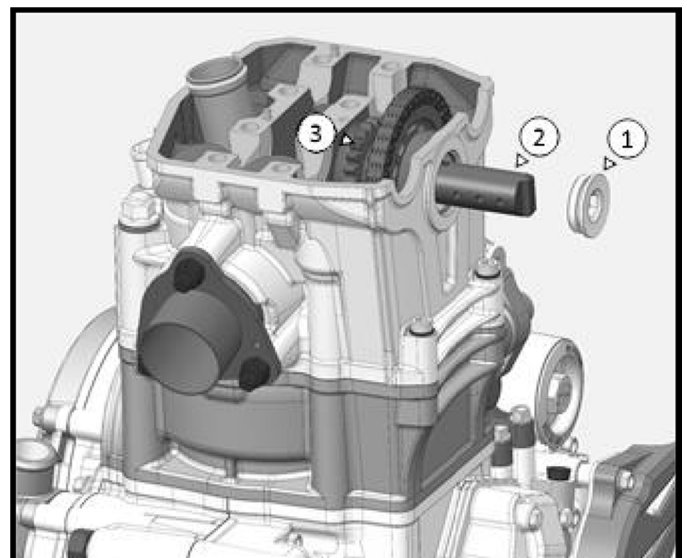

REMOVING THE ENGINE

» Removing the cylinder head

- Unscrew the cylinder head bolts following the order indicated in the picture.
- Remove the cylinder head by pulling it vertically.
- Remove the cylinder head gasket with caution.

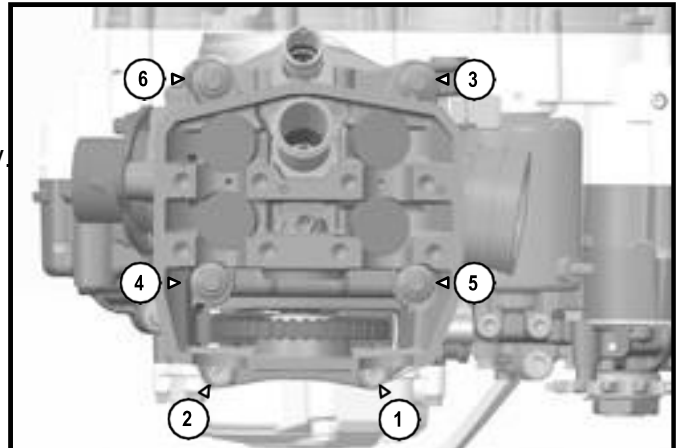

» Removing the cylinder

- Remove the cylinder by pulling it vertically.
- Remove the cylinder gasket (1) carefully.

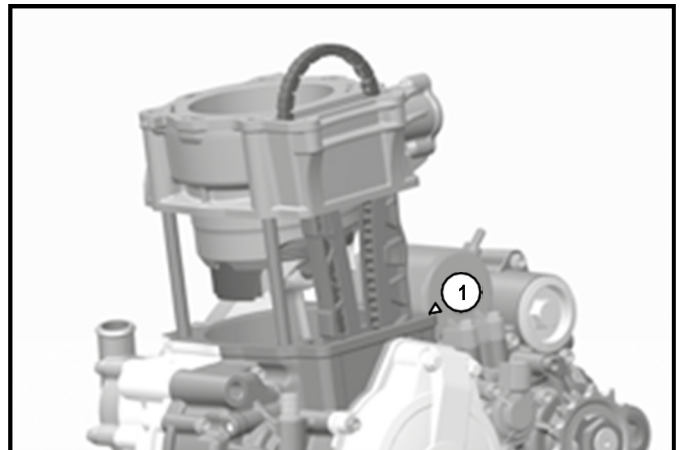

» Removing the piston

- Remove the securing clip (1) from the piston pin and remove the piston pin (2).
- Remove the piston.

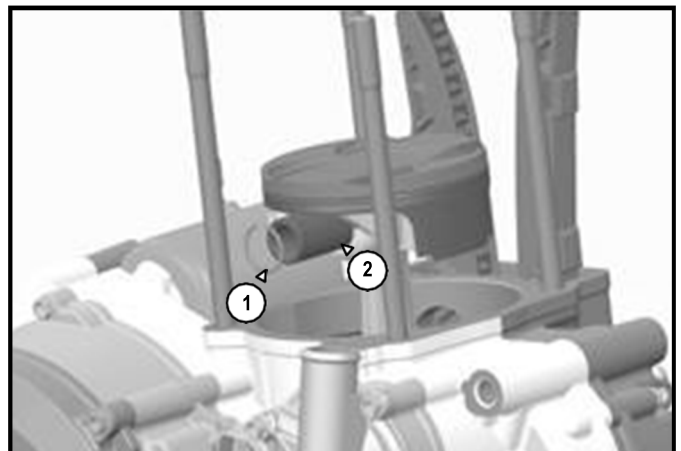

» Removing the ignition cover

- Remove the 4 screws (1) and remove the ignition cover.
- Remove the ignition cover gasket with caution.

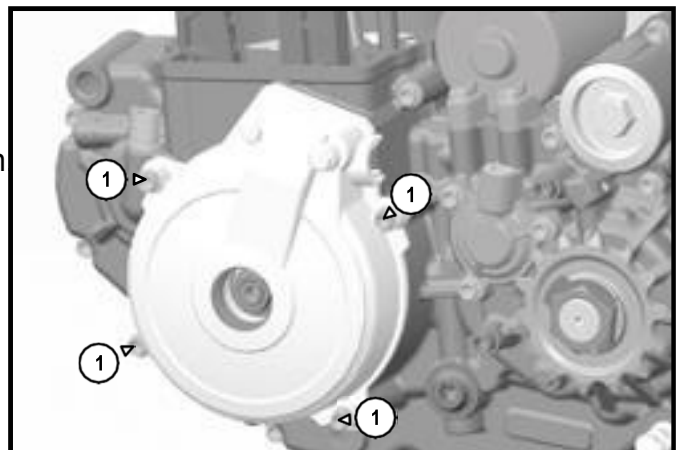

REMOVING THE ENGINE

» Changing the stator and the engine speed sensor

- Remove the 2 screws from the sensor (2) and the two screws from the stator (1).
- Set up the new parts.
- Reinstall the screws with red thread lock and tighten to 7 N.

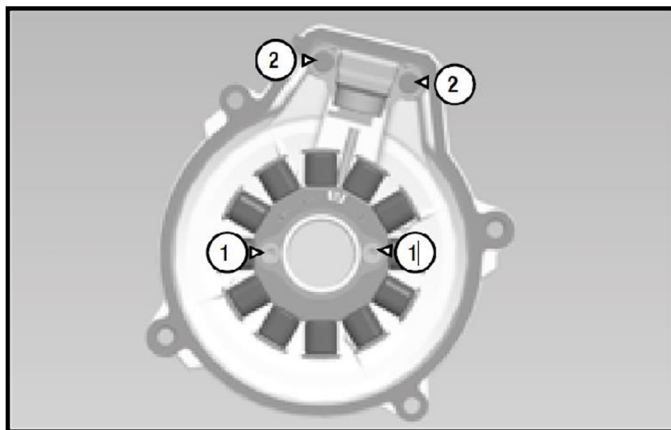

» Removing the rotor

- Use the rotor maintenance tool 4753.
- Unblock the central nut.
- Extract the flywheel with the flywheel extractor R462.



» Removing the drivechain

- Unscrew the drive chain guide plates (1) and (2)
- Remove the drive chain.

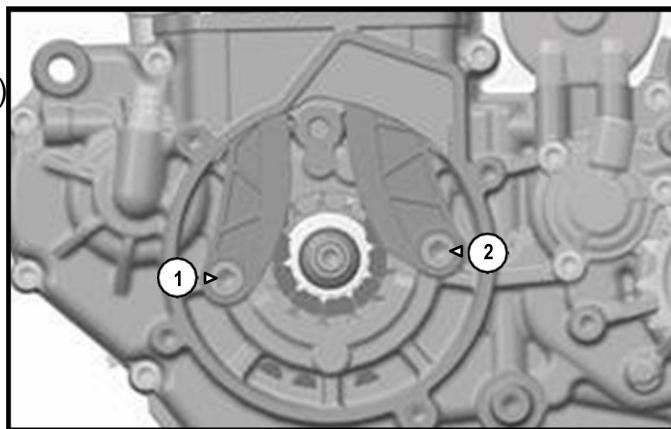

» Removing the electric starter

- Unscrew the two screws (1) and pull horizontally to the left.

Remove the oil filter, if not done yet.

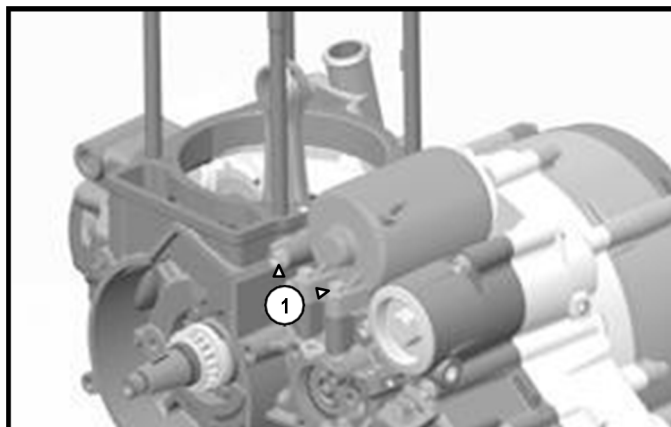

REMOVING THE ENGINE

» Removing the clutch

- Remove the clutch housing cover by unscrewing the 4 screws. Beware of the O-ring located on the rim of the cover.
- Set the TDC 1819 tool.

WARNING

Do not use this tool for tightening or loosening with a torque value higher than 10 Nm.

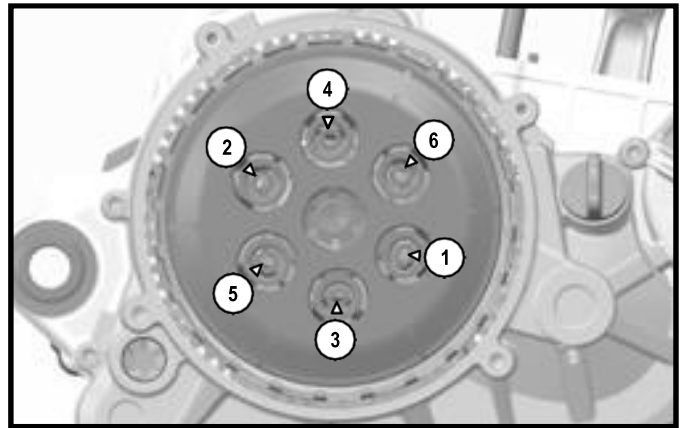

- Remove the 6 screws from the pressure plate.
- Remove the friction and metal plates.
- Make sure the inner clutch hub can freely rotate.

» Removing the water pump housing

- Remove the screws (1) of the water pump housing. Beware of the O-ring located on the rim.

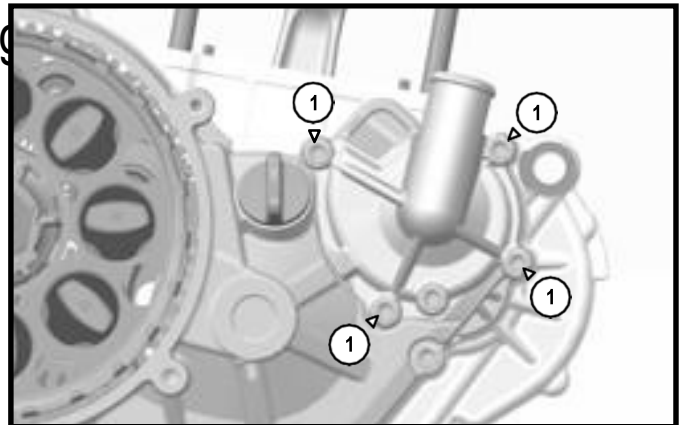

» Removing the clutch housing

- Dismount the 8 screws of the clutch housing.

WARNING

You need to identify the screws, 6 are 25 mm long, 2 are 30mm long (screw (1)).

- Remove the clutch housing and remove the seal carefully.

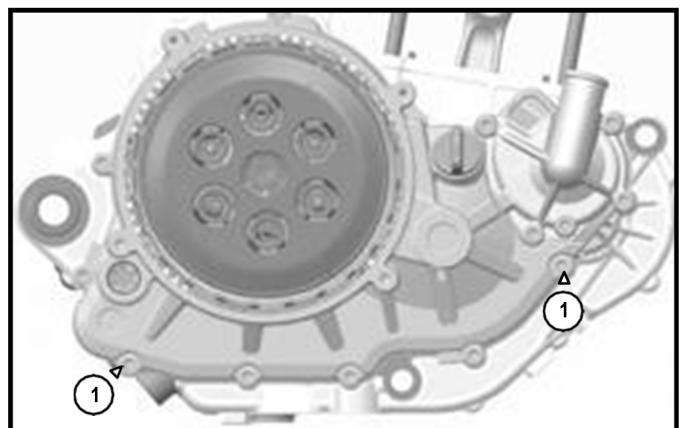

REMOVING THE ENGINE

» Removing the water pump oil seal and the bearing

- Remove the water pump turbine with a 10 socket by unscrewing it while holding the drive pinion.
- Remove the water pump shaft. Both oil seals have been made accessible.

WARNING

The 2 seals are not identical nor interchangeable

- Disconnect the shaft from the water pump drive pinion.
- Remove the water pump bearing.

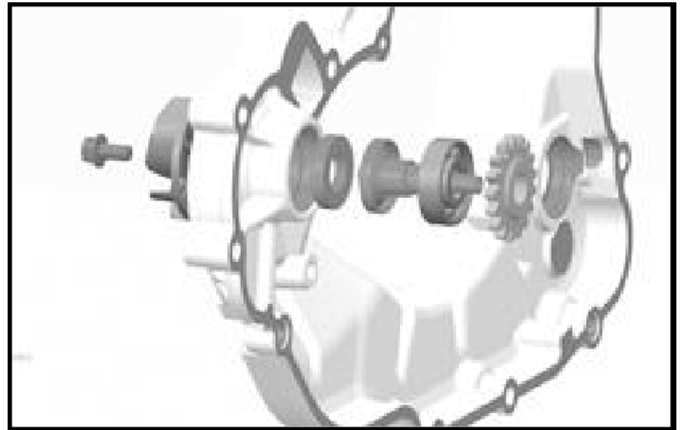

» Removing the clutch bellhousing

- Remove the finger follower from the clutch hub
- Flatten the safety tab.
- Block the clutch hub using the 5749 and unscrew the nut.
- Remove the hub, the notched washer and the bellhousing.
- Remove the drive pinion of the oil pump if it does not remain stuck to the bellhousing.
- Check the needle bearings and change them if necessary
- Visually check the clutch bellhousing.

WARNING

If you want to dismantle the freewheel or the balancer shaft further on, block the primary drive with the tool 5593. Unlock the nut off the mass of the balancer shaft (2).

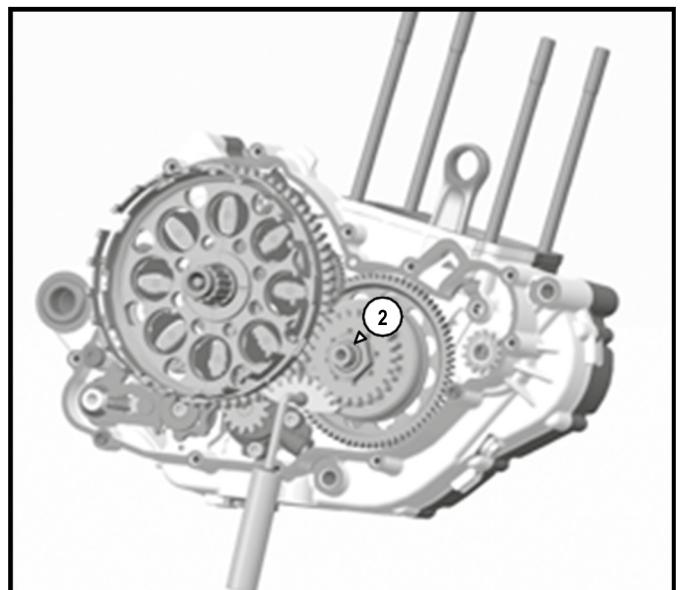
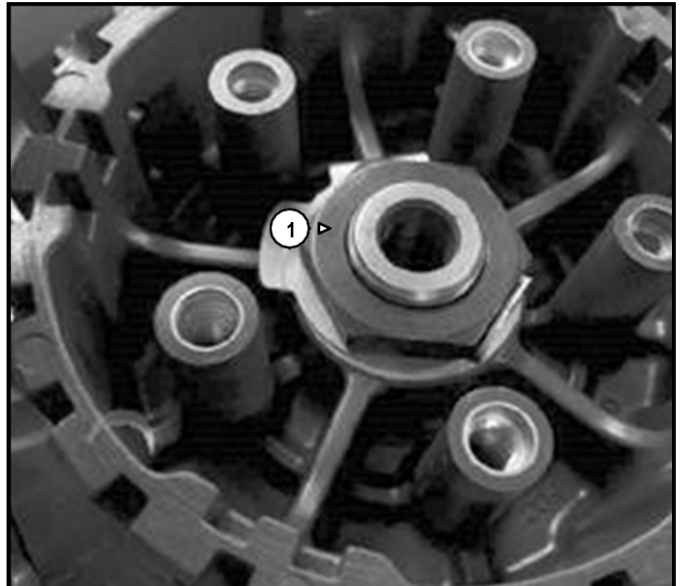

REMOVING THE ENGINE

» Removing the freewheel sprocket

WARNING

See previous paragraph for the unlocking of the balancer shaft nut.

- Remove the securing clip (1) and their washers.
- Remove the torque limiter (2).
- Remove the oil pump intermediate pinion (3).
- Unscrew the nut and remove the freewheel bellhousing (4) with a 2-arm puller.

WARNING

Do not damage the end of the crankshaft: oil passage, pin lubrication and lip sealing.

- Remove the freewheel sprocket.

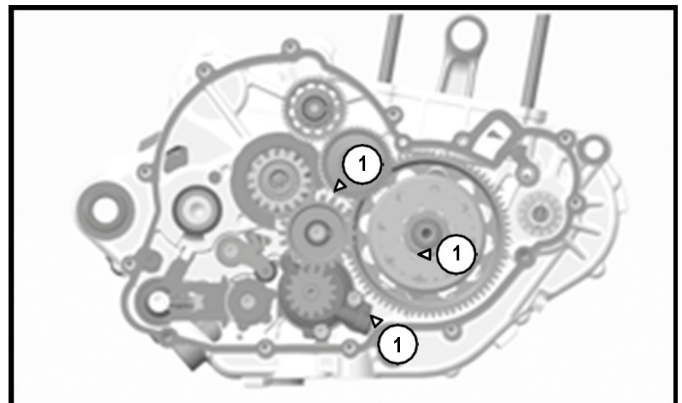
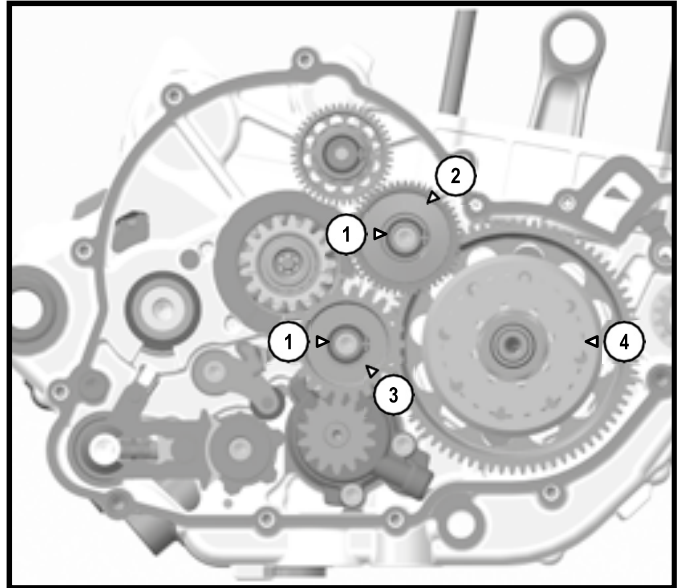

» Removing the oil pump

- Remove the oil pump intermediate pinion.
- Remove the 3 screws (1).

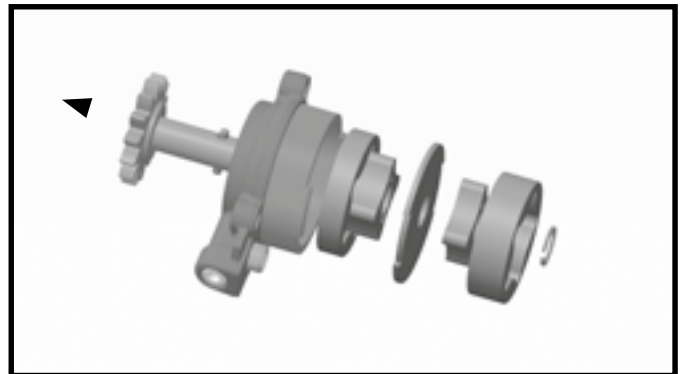

» Changing the oil pump

- Remove the securing clip in pin end condition and remove it.

WARNING

The pump to the left of the wall is 8mm thick and the one to the right is 12mm thick.

» Removing the index shim

- Keep the selection locking latch blocked (1)
- Pull on the scorpion and remove the selector shaft.
- Unblock the index shim and the locking latch with an Allen key (2).

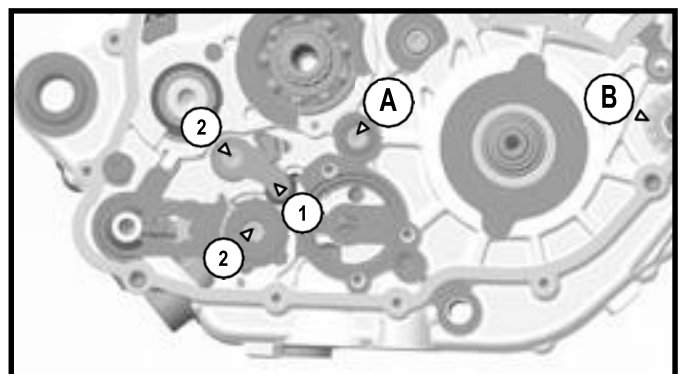

REMOVING THE ENGINE

» Separating the central crankcases

- Remove the screw (A- p.19) with an Allen key.
- Remove the water pump drive pinion (B - p.19) by removing the securing clip. Beware of the needle that may fall
- Turn the housing over and remove the 14 screws of the central crankcase: (1) length 45 mm x 10; (2) length 55 mm x 1; (3) length 75 x 3.
- Separate the central crankcases.

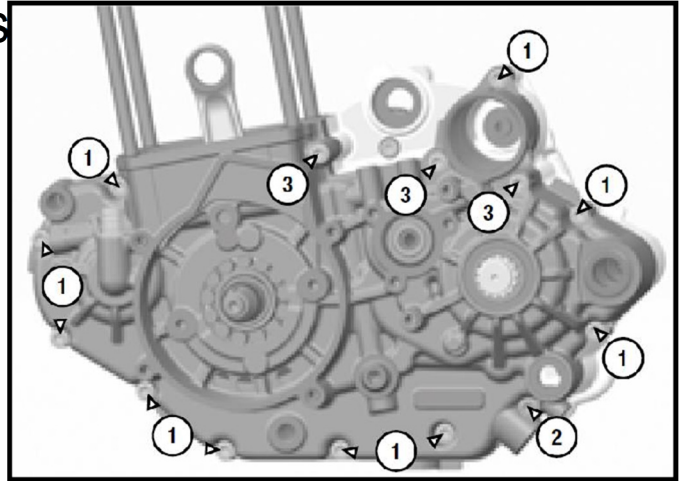

» Removing the gearbox

- Remove the two fork spindles (1).
- Remove the selection drum.

BEWARE

Of the small fork sockets.

- Remove the forks C, L and R.
- Remove the two gearbox shafts.

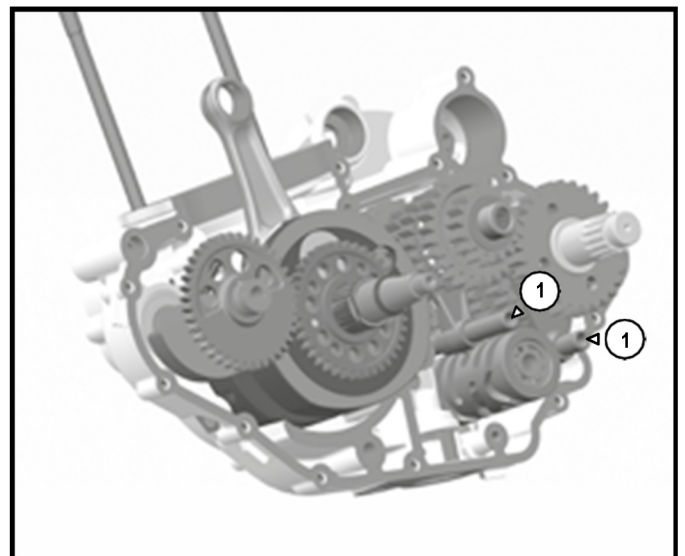

» Removing the crankshaft

- Remove the balancer shaft.
- Remove the crankshaft.

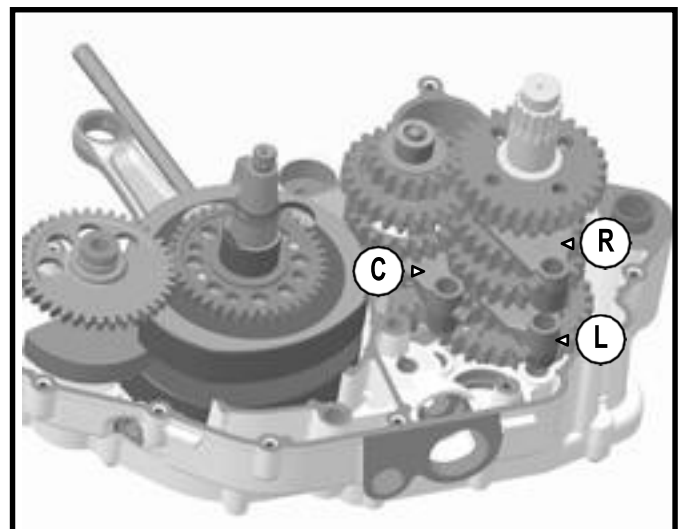

CHECKING INDIVIDUAL PARTS

» Controlling the central crankcases

- Check the general condition of the central crankcases for any possible damage or crack.
- Change the defective or worn crankcase set if necessary.
- Check the condition of the bearings. Change them if necessary.

» Left crankcase

- The crankshaft bearings (1), primary shaft (2) and secondary shaft (3) of the gearbox are held by some screws and/or plates.
- Balancer shaft bearing (4).
- Check the bearings, replace them if necessary.
- Remove the bearings.
- Check that their housing is clean and install the new bearings, hot crankcase at about 70 °C.
- Apply blue thread lock on the bearings of the retaining screws and **tighten them to 5 Nm**.
- Check that the top engine oil nozzle (5) and BV (6) is not clogged or damaged.

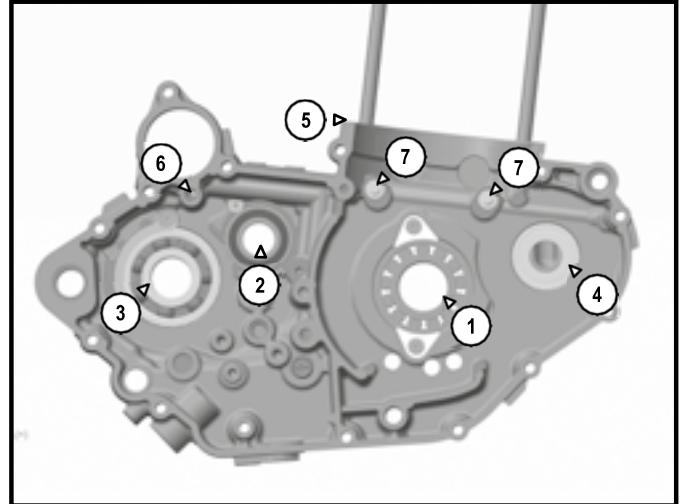

WARNING

The piston nozzles (7) are indexed and cannot be replaced. If damaged, replace the carters.

» Right crankcase

- The crankshaft bearings (1), primary shaft (2) and secondary shaft (3) and selection drum (4) are secured by screws and/or plates.
- Balancer shaft bearing (5).
- Check the bearings, replace them if necessary.
- Remove the bearings.
- Check that their housing is clean and reinstall the new bearings, hot crankcase at about 70 °C.
- Apply blue thread lock on the bearings of the retaining screws and **tighten them to 5 Nm**.
- Check that the oil nozzle (6) and (7) (external side) is not clogged.

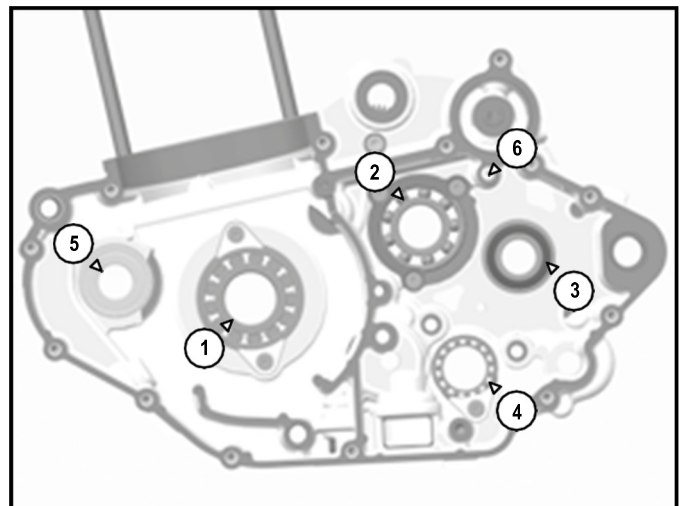

CHECKING INDIVIDUAL PARTS

›| Checking the freewheel sprocket bearing

- Visually check the needle bearing of the freewheel sprocket.
- Change it if necessary.
- Check the visual aspect of the rolling raceway of the freewheel sprocket (1).
- Change the pinion if necessary.
- Check the visual aspect of the freewheel, its clearance with your hand, as well as its capacity to freely rotate.
- Replace it if necessary; remove the outer securing clip (2) and remove the freewheel.

WARNING

Replacing the freewheel systematically involves replacing the freewheel sprocket and vice versa.

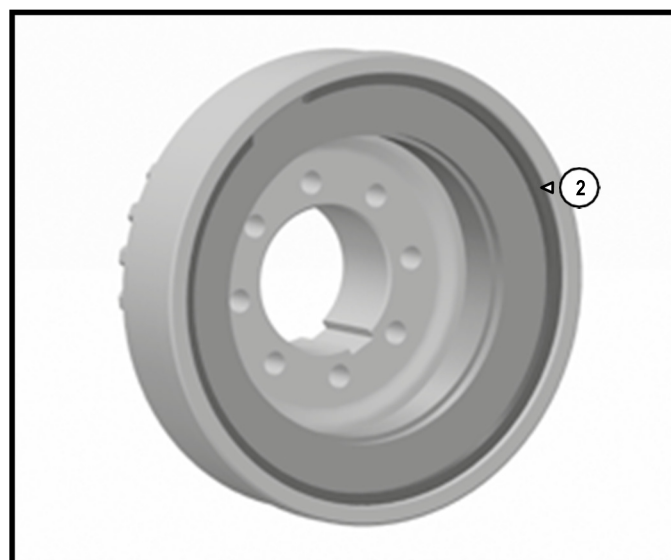
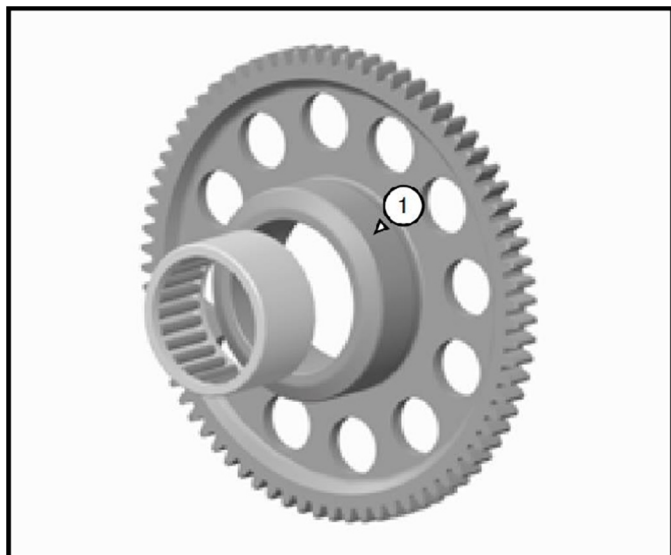

›| Changing the crankshaft bearings

- Change the corresponding bearings (outer rings) on the central crankcases.
- Pull out the distribution drive pinions with a 2-arm puller.
- Retrieve the inner rings of the crankshaft bearings by heating the R464 tool and the ring.

WARNING

The radial clearance of the bearings must be practically zero.

- To remove the drive pinion of the balancer shaft, tighten 2 screws 8x125 in the holes provided for this purpose.



CHECKING INDIVIDUAL PARTS

» Checking the crankshaft

Radial clearance of the connecting rod :

- Place the crankshaft on V-blocks and place a dial gauge [A] against the connecting rod.
- Push [B] the connecting rod to the gauge and then in the opposite direction. The difference between those two measurements is the radial clearance.

Radial clearance of the connecting rod :

Standard : 0.008 mm – 0.012 mm

Tolerated limit : 0.05mm

If the radial clearance exceeds the limit, the crankshaft must be replaced.

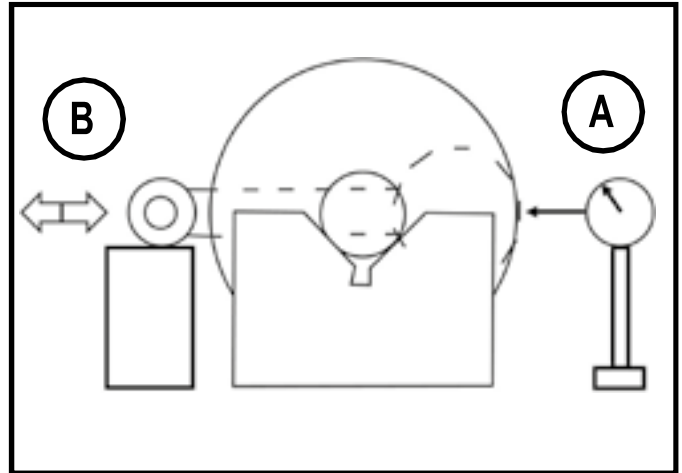

Lateral clearance of the connecting rod :

- Measure lateral clearance of the connecting rod [A].

Lateral clearance of the connecting rod :

Standard : 0.6 mm - 0.85mm

Tolerated limit : 1.1 mm

If the radial clearance exceeds the tolerated limit, replace the crankshaft.

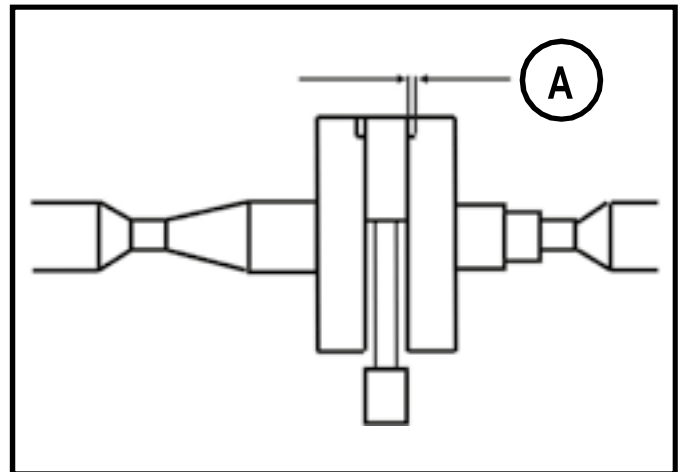

Checking the runout :

- Place the crankshaft on alignment devices or Vblocks, and place a gauge as shown in the image.
- Then slowly turn the crankshaft. The maximum difference between the measurements corresponds with the offset of the crankshaft.

Runout :

Standard : 0.02 mm maxi

Tolerated limit : 0.08 mm

If the offset is not correct, replace the crankshaft and align it so to be within tolerated limits.

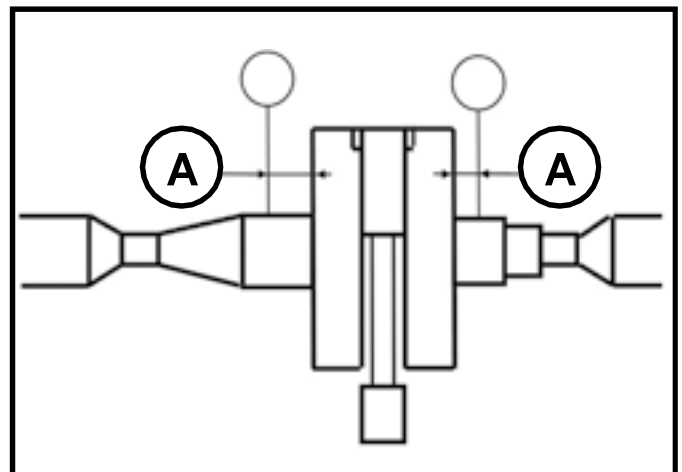

CHECKING INDIVIDUAL PARTS

» Checking the gearbox

- Check all pinions
By checking the coupling claws [A], the pinion teeth [B] and fork grooves [C]. In case of wear, damage, change the affected pinions.
- Check the condition of the gearshift forks.
- Change the forks if necessary.
- Control the selection drum, check if there are distortions, anormal wear, if damage is found. Change the drum if necessary.

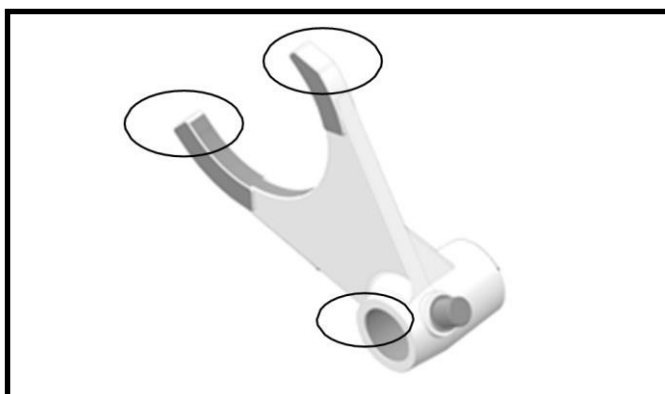
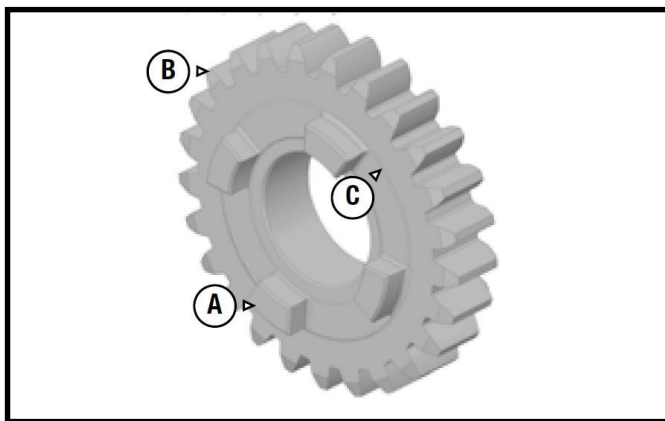

» Checking the clutch

Check metal and friction discs:

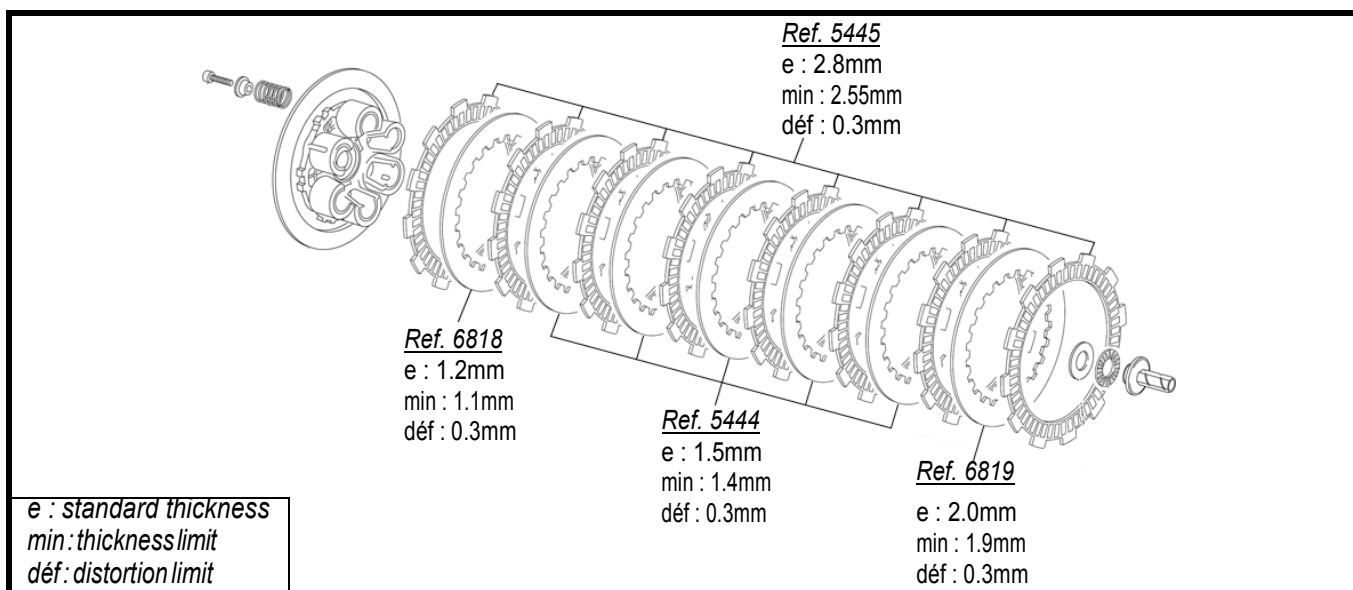

Checking the clutch springs :

- Measure the free length of the springs.
Standard : 50.0mm
Limit : 49.0mm

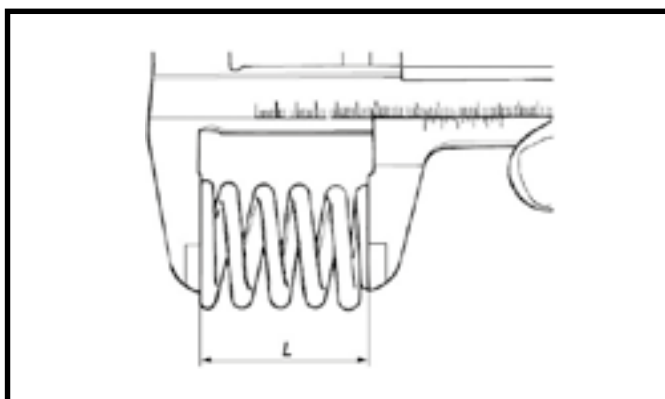

CHECKING INDIVIDUAL PARTS

» Checking the top-engine

Inspection of cylinder wear :

Measure the inside diameter of the cylinder when the cylinder is cold

- Inspect the inside part of the cylinder for scratches or any other sign of abnormal wear. If the cylinder is damaged or severely worn, replace it.
- Since the cylinder does not wear out evenly in every direction, measure it from one side to the other and from bottom to top as shown.

If one measure of the internal diameter of the cylinder exceeds the service limit, replace the cylinder.

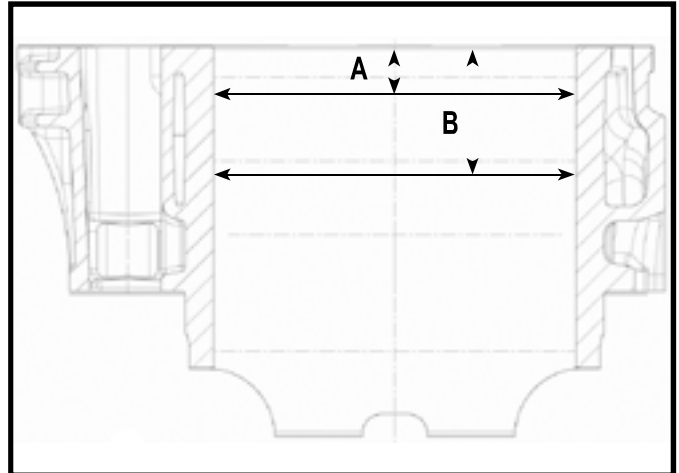

(A)=8 mm
(B)=30 mm

Standard 450 SEF :

Cylinder diameter (A) = 94.99 ± 0.012 mm
Cylinder diameter (B) = 94.982~94.995 mm
Conicity limit 0.05 mm
Ovalization 0.05 mm

Standard 500 SEF :

Cylinder diameter (A) = 97.990 ± 0.008 mm
Cylinder diameter (B) = 97.99~98.005 mm
Conicity limit 0.05 mm
Ovalization 0.05 mm

Piston/cylinder clearance

In order to define the clearance as accurately as possible, measure the diameter of the piston and the cylinder separately, and then calculate the difference between these two values. Measure the diameter of the piston according to the « Piston Wear » procedure.

Piston/cylinder clearance :

Standard 0.034~0.056 mm
Limit 0.11 mm

CHECKING INDIVIDUAL PARTS

Piston wear :

- With the help of a micrometer, measure the outside diameter [A] of piston 15 mm [B] above the bottom of the piston and at a right angle in relation to the piston pin.

If the outside diameter of a piston is below the limit, replace it

Piston 450 SEF= 94.93 - 94.95

Piston 500 SEF= 97.93-97.95

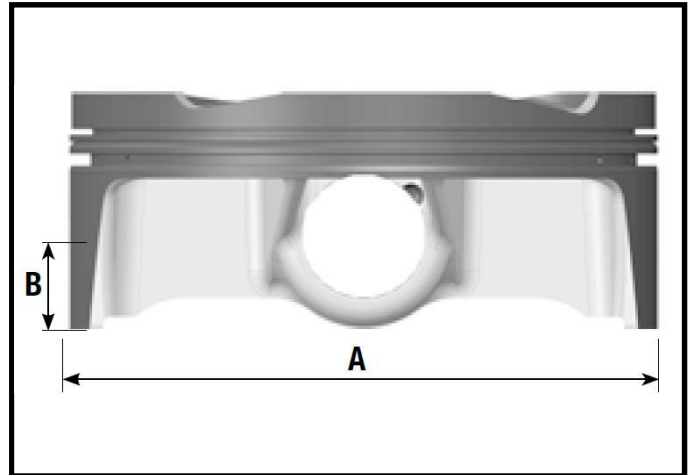

Ring/ring groove clearance :

- Check the base of the ring in order to verify that the grooves do not show uneven wear.
- Once the rings are properly set in their grooves, perform several measurements with a thickness gauge to determine the ring/ring groove clearance.

Top ring: 0.020-0.065 mm
Limit 0.13 mm

Oil scraper ring : 0.020-0.055 mm
Limit 0.13 mm

End gap :

Top ring : 0.2-0.3 mm
Limit 0.5 mm

Inspection for wear of the connecting rod, piston pin, and piston :

- Visually control the installed securing clip. If it seems weakened or distorted, replace it. If the groove of the pinhole is excessively worn, replace the piston.
- Measure the diameter of the piston pin by means of a micrometer. If wherever along the line, the diameter of the piston pin happens to be inferior to the limit, replace the shaft.
- Measure the diameter of the two piston pinholes in the piston and the inner diameter of the connecting rod bushing. If one of the diameters of the holes measured on the piston is incorrect, change the piston.

If the diameter of the connecting rod bushing is incorrect, replace the connecting rod.

Diameter of the piston pin : 18.995-19.000 mm

Diameter of the piston pin hole : 19.004-19.009 mm

Inner diameter of the connecting rod bushing : 20.007-20.013 mm

CHECKING INDIVIDUAL PARTS

Cam wear :

- Measure the height [A] of each cam by means of a micrometer.

If the cams are worn beyond the limit, replace the camshaft.

Cam height limit 450

Exhaust : 37.20 mm

Admission : 37.62 mm

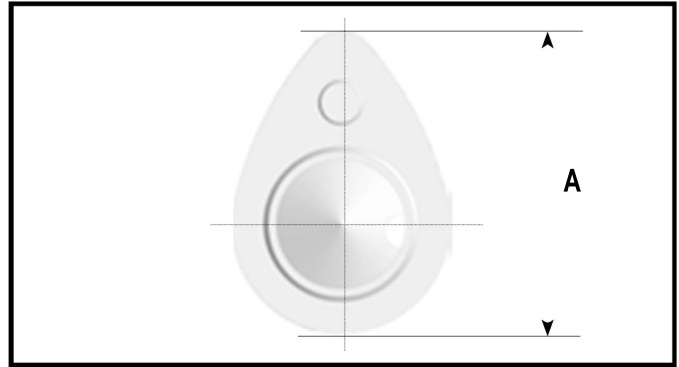

Wear of the camshaft and camshaft bearings:

- Measure all clearances between the camshaft trunnion and the camshaft bearings by means of a plastic gauge [A]. Tighten the camshaft housing screws after coating their body and threading with engine oil.

Torque setting

Camshaft housing screws : 18 Nm.

If any clearance is above the limit, measure the diameter of each camshaft trunnion by means of a micrometer.

If the diameter of the camshaft pin is below the limit, replace the camshaft and measure the clearance again.

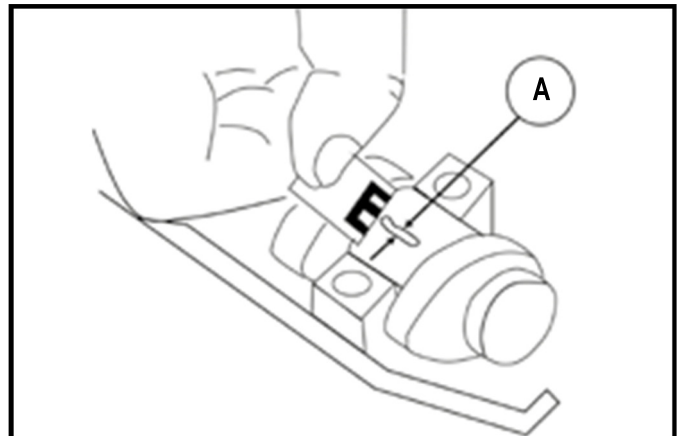

Diameter of the standard camshaft trunnion

Standard : 23.980 – 23.993 mm

Limit : 23.960 mm

If the clearance remains outside the service limit, replace the cylinder head.

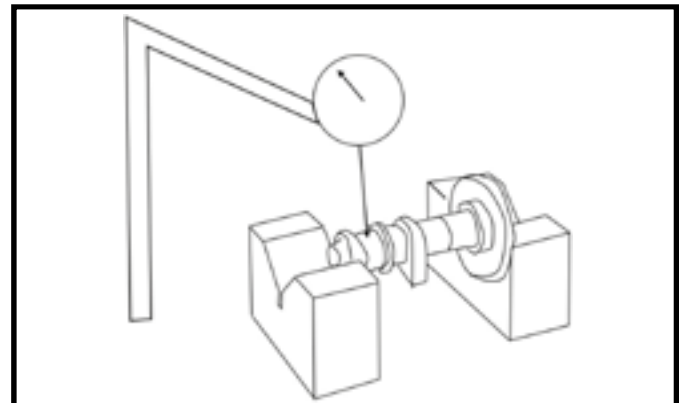

Camshaft offset :

Measure the runout of the camshaft.

If it is out of specification, change de camshaft.

Runout : Less than 0.03 mm.

CHECKING INDIVIDUAL PARTS

» Checking the cylinder head

Cylinder head inspection for warping :

- Place a ground ruler [A] on the lower surface of the cylinder head at different positions, and measure the warping by inserting a thickness gauge between the straightedge and the gauge head. If the warping exceeds the tolerated limit, repair the adjusting surface. Replace the cylinder head if the adjusting surface is seriously damaged.

Warping of the cylinder head :

Limit = 0.05 mm

Valve/guide clearance :

Intake :

Minimum clearance : 0.02 mm

Maximum clearance : 0.045 mm

Exhaust :

Minimum clearance : 0.04 mm

Maximum clearance : 0.065 mm

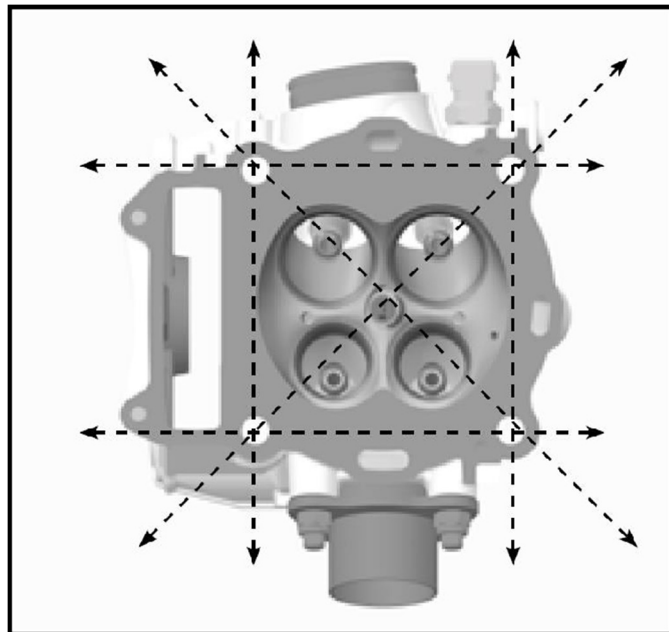

» Checking the distribution

- Clean all parts.
- Visually inspect the drive chain : check for any hard spot, resistance, or wear. If any, it must be changed.
- Visually inspect the distribution drive pinion. Change if necessary.
- Visually inspect distributions guide plates: change them if necessary.
- Visually inspect the pinion (1) ; replace if necessary.
- Check that the needle bearings fit tight when the pinion (1) is mounted on its axis.

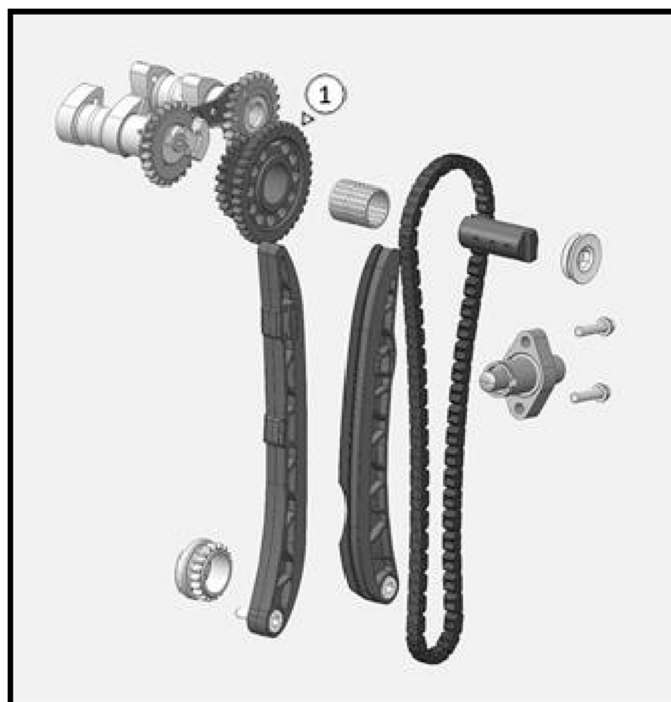

» Installing the central crankcases

WARNING

During the installation process, replace all gaskets (joint paper, O-ring, etc.).

- Turn the crankshaft and the balancer shaft in the right crankcase by aligning the two marks.
- Fit the two gearboxes shafts.
- Put a roller on each fork.
- Put the shift forks in their respective sliding grooves.
- Insert the selection drum.
- Insert the forks in their respective drum grooves.
- Place the fork spindles.

WARNING

Do not forget to oil the parts in friction or in rotation.

- Set up the two guide pins (A) and the washer (1) on the secondary shaft.
- Place the right crankcase on the preassembled parts.

- Put the 13 central crankcase screws and tighten. 10 screws (B) length 45 mm; 1 screw (C) length 55 mm; 3 screws (C) length (D) length 75 mm.

Tightening torque of the central crankcase screws : 10 Nm.

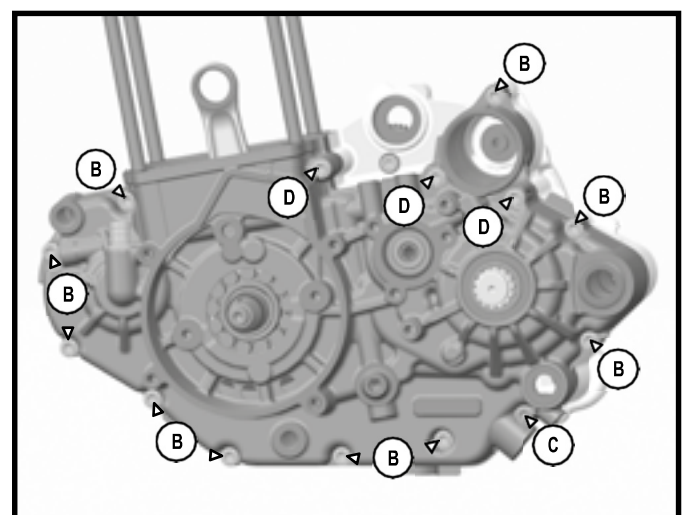
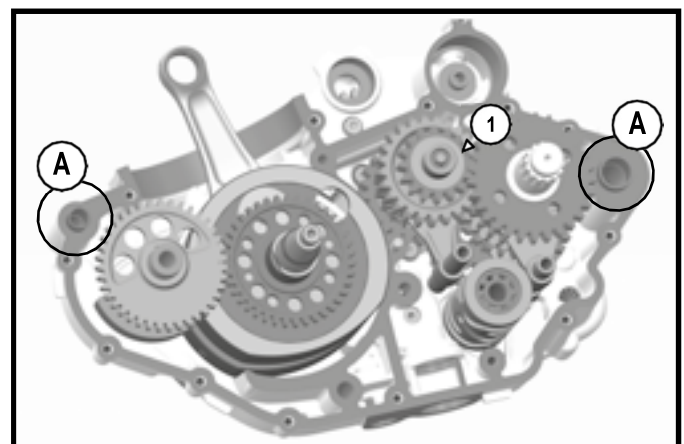
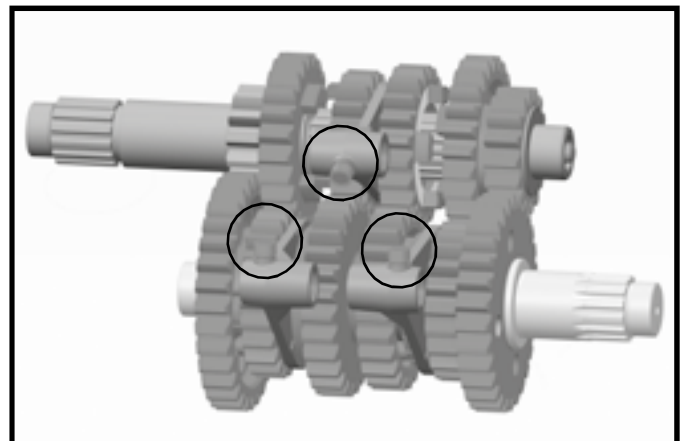
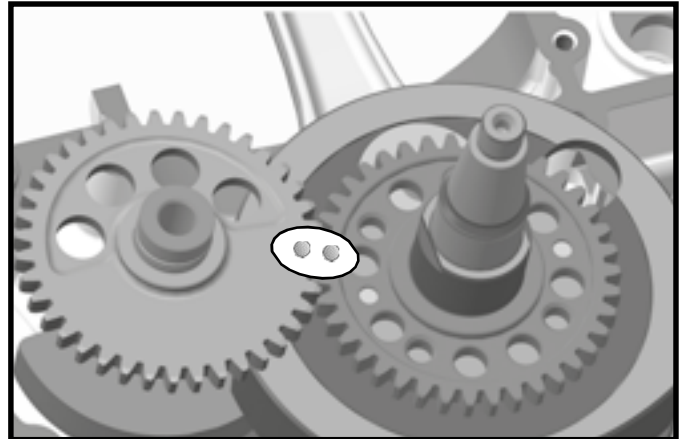

- Turn the crankcase over and tighten the screw (3)
Torque setting : 10 Nm.

- Pull the locking finger by placing back the spring properly.
- Hold the speed-locking lever locked.
- Do not forget the needle (2) on the drum.
- Mount the star and apply blue thread lock on the drum screw and tighten it.

Specified torque of the drum screw: 10 Nm.

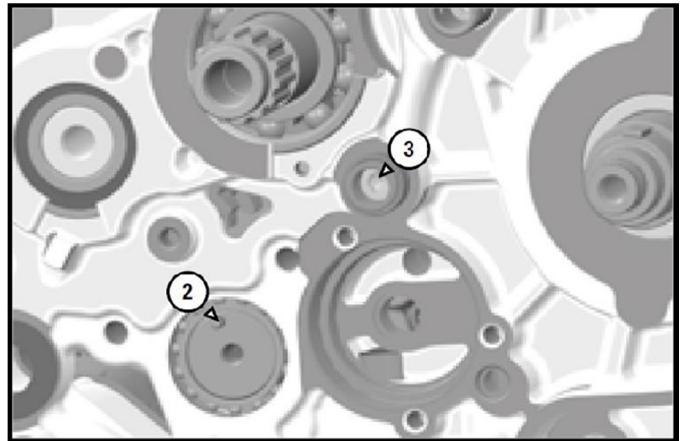

- Place back the shaft selector taking good care to slide the spring back to its slot.
- Fit the oil pump previously assembled and tighten the 3 retaining screws after applying medium thread lock.

Tightening torque of the oil pump housing screws: 10 Nm.

- Place the needle, the water pump drive pinion and its securing clip.
- Set the freewheel pinion and its needle bearing.
- Set up the freewheel and the assembled freewheel bellhousing (5) while properly indexing the crankshaft and its woodruff key.
- Remove all grease with a solvent from the primary shaft and from the crankshaft threading.
- Apply medium thread lock on the crankshaft
- Fit the washer and engage the nut (4).
- Place the oil pump intermediate gear.
- Place the securing clip (3) and its washer.
- Place the torque limiter (2).
- Place the securing clip (1) and the limiter shaft washer.
- Set the two needle bearings on the primary shaft.
- Place the pinion on the primary shaft and the clutch bellhousing. Be careful to align the notches on the pinion with the bellhousing.

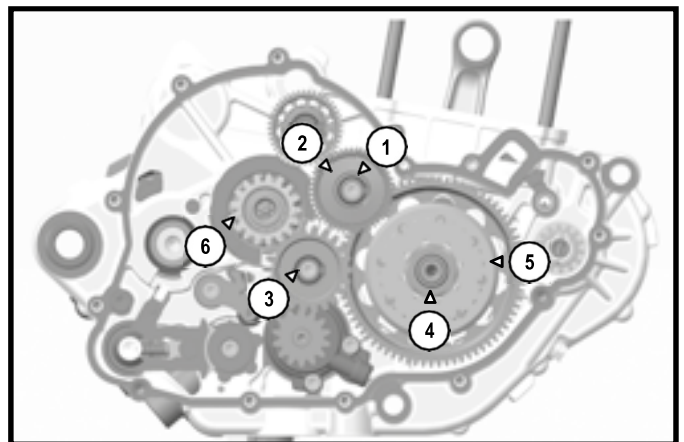

Put the grooved washer and the inner clutch hub.

- Using the 5593 tool, block the transmission and tighten the nut.

Specified torque of the crankshaft nut : 120Nm.

- Insert the safety washer and the nut.
- Using the 5749 tool, block the clutch nut and tighten.

Specified torque of 100 Nm nut clutch.

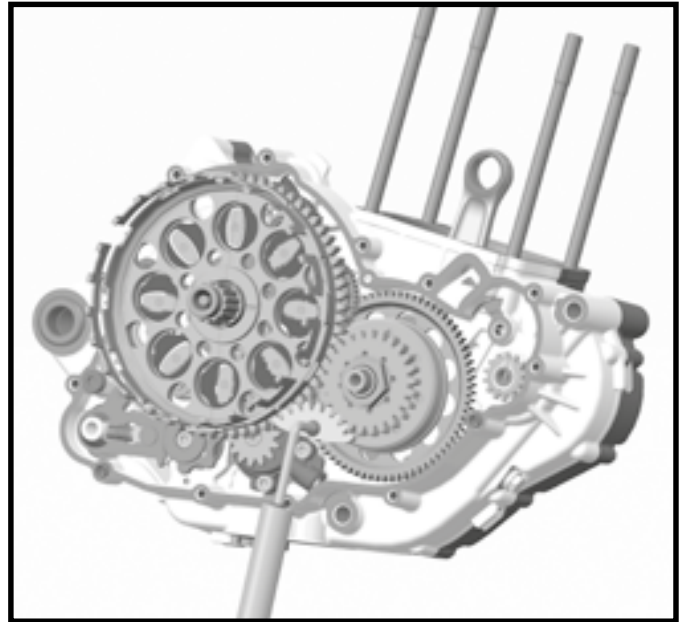

» Installing the clutch housing

- Heat the housing to approximately 70 °C.
- Place the water pump on top of the clutch housing.
- Check the condition of the oil pan gasket and set it back.
- Reassemble the clutch housing and the 8 screws outside the water pump housing.

Tightening torque of the clutch housing: 10 Nm.

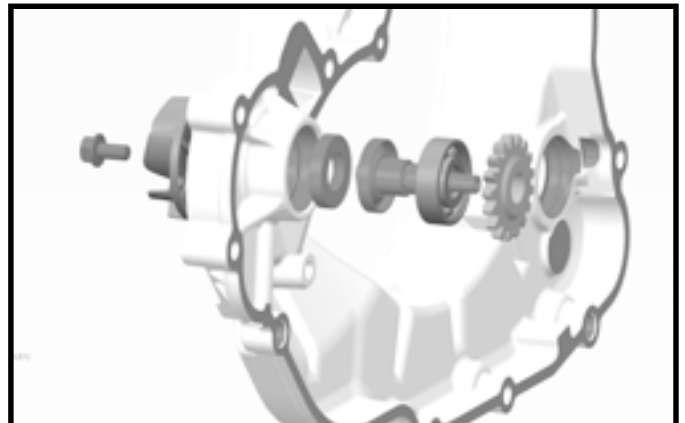

WARNING

*Make sure that the lubrication raceway of the crankshaft in the crankcase is clean.
Replace the crankshaft lip seal.*

» Installing the water pump housing

- Place the screws (1) of the water pump housing.
- Be careful to correctly position the O-ring located on the rim.

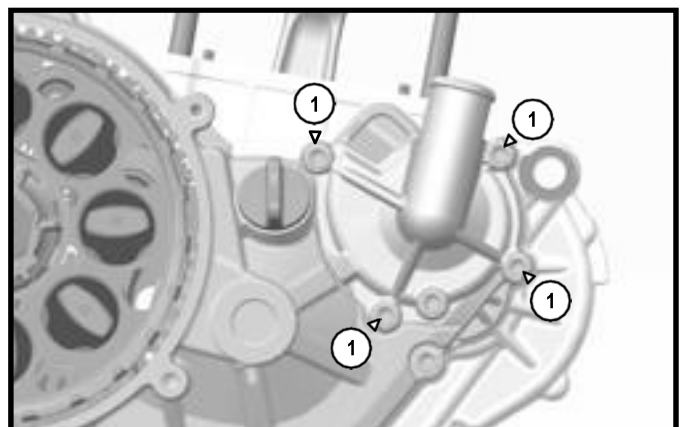

» Installing the clutch

- Put the 8 friction discs and the 7 metal discs, starting with a friction disc.
- Install the finger follower and do not forget to install the stop and the washer.
- Put the pressure plate and the 6 screws following the order shown in the picture.
- Place the TDC 1819 tool.

WARNING

Do not use this tool for tightening or loosening at a torque value superior to 10 Nm.

- Place the clutch housing cover by tightening the 4 screws. The 4 screws are not the same length.
- Beware of the O-ring located on the rim of the lid.
- Remove the TDC 1819 tool.

Tightening torque of the plate screws : 10 Nm.

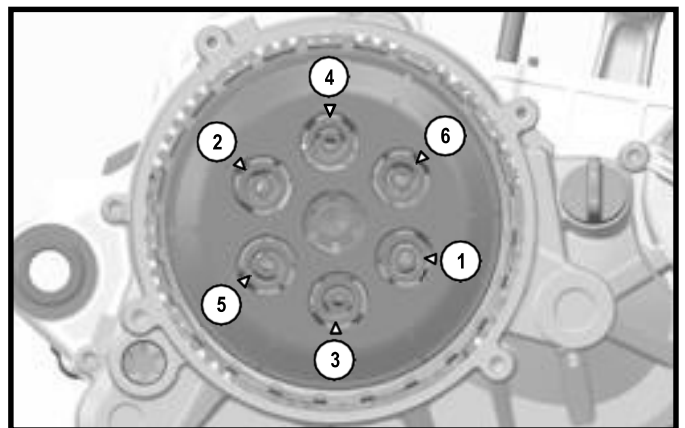

» Installing the electric starter

- Lubricate the starter O-ring.
- Fit the electric starter and tighten the 2 screws.

Tightening torque of the starter : 10 Nm.

» Setting the piston rings

- Place the first rail. Pay attention to the position of the opening on the exhaust side.
- Place the expander on the bottom groove (the widest). The opening should be placed in the middle. Please note that ripple ends must be oriented downwards.
- Place the rails below and above the expander within the groove. Make sure that the upper rail is on the intake side (opposite the first rail).
- Place the top ring in the upper groove. The opening should be on the exhaust side. Make sure that the ring is oriented upwards.

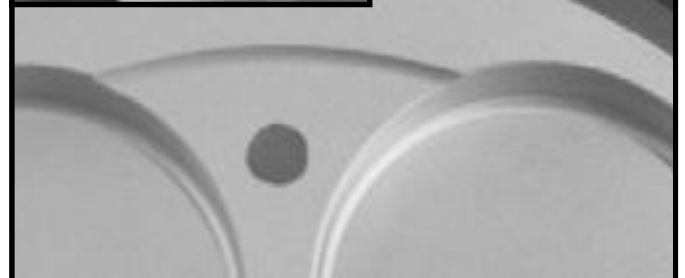
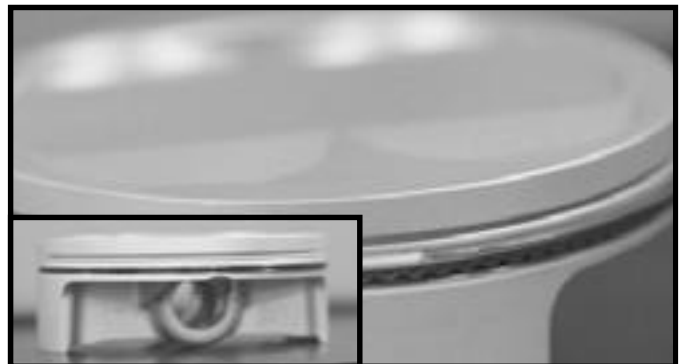

» Installing the piston

- Set the piston and piston rings.
- Lubricate the piston pin and place it.
- Set the piston pin-securing clip.

» Installing the cylinder

- Seal the joint between the left and right casing with sealing dough.
- Set the guide pins and a socket joint.
- Lubricate the piston skirt.
- Oil the cylinder.
- Fit the cylinder paying attention to the rings.
- Place the piston at TDC and the 1819 tool.

» Installing the cylinder head

- Set the guide pins and the cylinder head gasket.
- Set the washers and nuts.
- Screw the cylinder head in the order shown in the picture.

Pass 1

Tightening torque of nuts 1/2/3/4 : 30 Nm.

Pass 2

Tightening torque of nuts 1/2/3/4: 50Nm.

Tightening torque of screws 5/6: 10Nm.

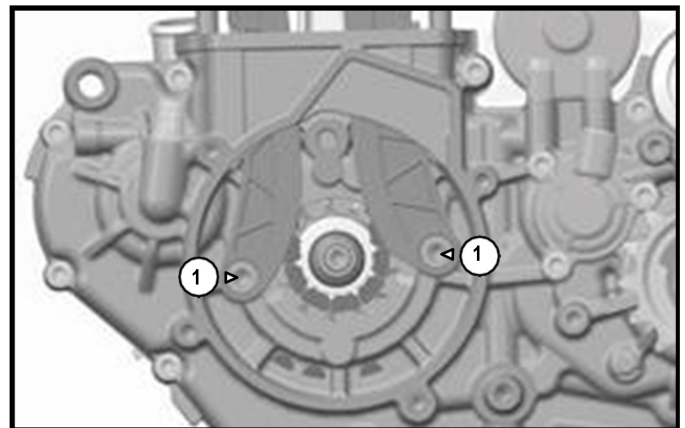
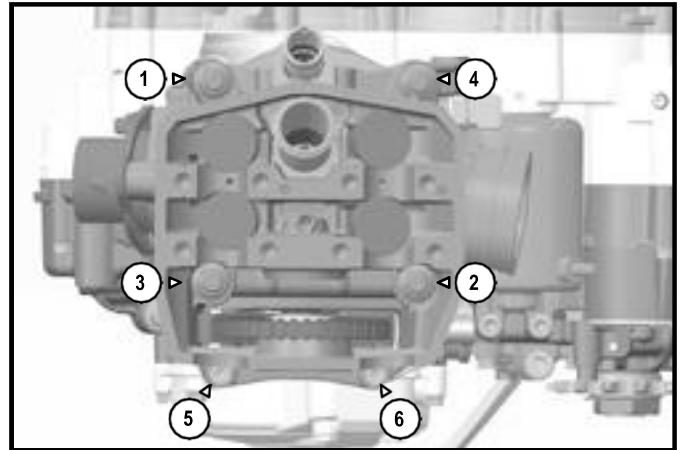

» Installing the drive chain

- Set the 2 distribution guide plates going through the chain well.
- Fit the chain on the crankshaft pinion.
- Put the distribution upper pinion.

WARNING

Make sure that the mark is vertical to the cylinder, or that the FLANGE mark is aligned with the cylinder head gasket plane.

- Do not forget the two-needle housing of the pinion.
- Place back the axis (2) and then the cap (1) with its O-ring.

Tightening torque of the cap (1) : 20 Nm.

- Apply blue thread lock on the two screws (1).

Tightening torque of the plate screws (1) : 10 Nm.

- Put in the drive chain.

Tensioner tightening torque : 10 Nm.

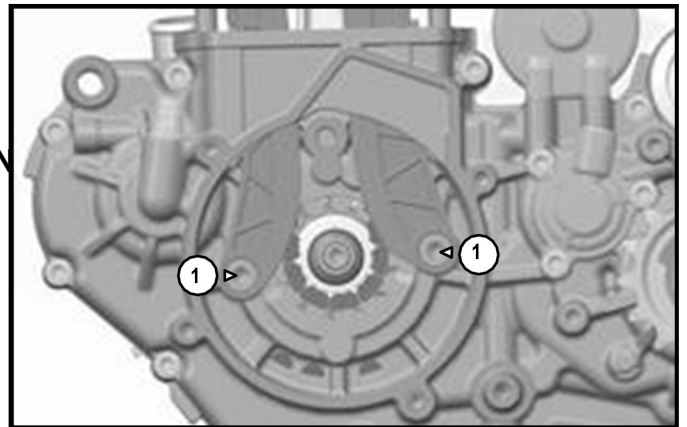
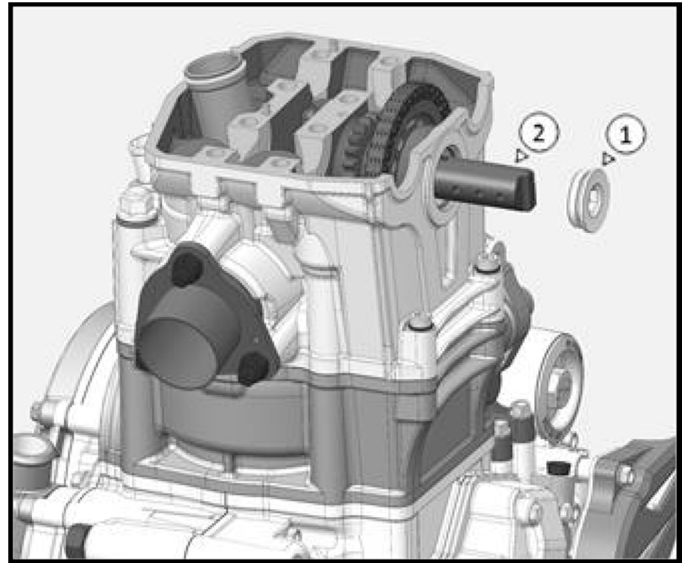

» Installing the rotor

- Place the rotor.
- Use the 4753 rotor holding tool.
- Put medium Loctite and tighten the central nut.

Tightening torque of the oil cap : 80 Nm.

» Installing the camshafts and setting the valve timing

- Clean and oil the bearings.
- Set the two camshafts and make sure that the visual marks «FLA» or «FLANGE» are aligned with the cylinder head gasket plane.
- Install the bearing cap (A).
- Screw the eight screws of the camshaft-bearing cap following the order shown in the picture.

Specified torque of the shaft bearing screws: 18 Nm.

- Remove the TDC 1819 tool.
- Using the ignition rotor, give the crankshaft at least one full turn and check the valve timing.

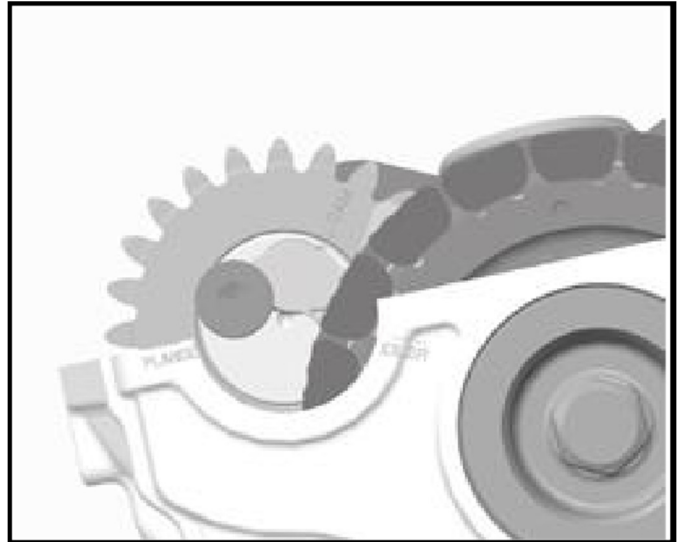

» Checking the valve clearance

- Valve clearance must be checked when the engine is cold.
- With a shim set, measure the clearance between the bucket and the camshaft.

Valve clearance

Intake	0.15 – 0.20 mm
Exhaust	0.20 – 0.25 mm

- If clearances are not correct, change the pads after removing the distribution.
- Remove the cups.
- Measure the pad, replace it in order to obtain the needed clearance.

For existing pad thickness models refer to the spare parts catalog.

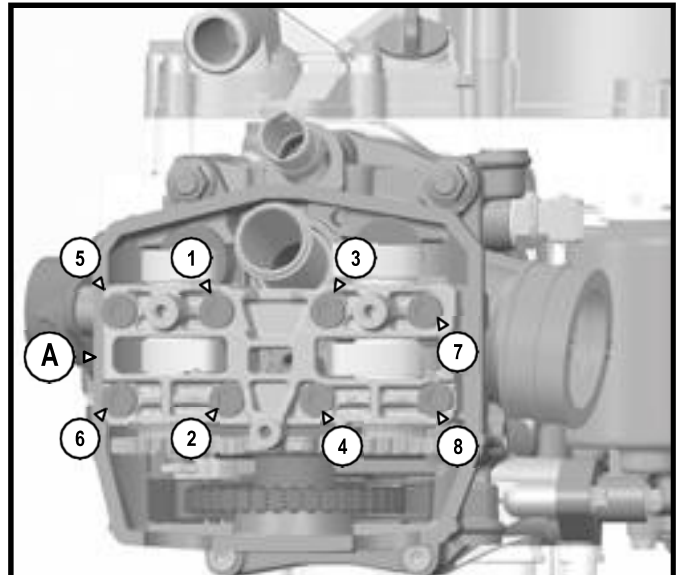

» Completing the engine assembly

- Clean the sealing surface of the cylinder head cover.
- Apply silicone sealant on both semi-circles.
- Fit the cylinder head cover gasket and cylinder head cover.
- Screw the cylinder head cover along with the O-rings of the 3 screws.

Tightening torque for screws cylinder head cover : 10 Nm.

- Applying copper grease on the threads of the spark plug.

Tightening torque of the spark plug : 16 Nm.

- Put in the TDC plug, tighten it to 15 Nm.

» Installing the ignition cover

- Set the guide pins.
- Fit the ignition cover gasket.
- Apply silicone dough on the wire guide.
- Put the 4 screws of the clutch housing.

Torque setting : 10 Nm.

- On the secondary shaft, put the O-ring, the spacer, the pinion and the washer.
- Apply red thread lock on the nut

Tighten to 100 Nm.

TIGHTENING TORQUE CHART

Standard tightening torque		Thread lock
M5	6 Nm	
M6	10 Nm	
M8	24 Nm	
M10	40 Nm	
Chassis tightening torque		Thread lock
Rear wheel nuts	100 Nm	
Rear cradle screws	24 Nm	•
Front wheel nut	25 Nm	
Fork foot pinch bolt	15 Nm	
Brake pads axis screws	8 Nm	•
Fork lower clamp pinch bolts	WP 12 Nm / KAYABA 12Nm	
Fork upper clamp pinch screws	WP 17 Nm / KAYABA 17 Nm	
Sachs engine axes	40 Nm	
Swing arm nuts	100 Nm	
Cylinder head screws (frame)	25 Nm	
Engine tightening torque		Thread lock
Magnetic drain plug	15 Nm	
Drain plug with pre-filter M18	15 Nm	
Drain plug with pre-filter M32	20 Nm	
Oil filter lid	15 Nm	
Spark plug (apply copper grease)	15 Nm	
Coolant bleed screw	6 Nm	

TIGHTENING TORQUE CHART

Engine torque setting		Thread lock
Engine speed sensor screws	7 Nm	•
Clutch receiver screws.	10 Nm	
Exhaust pipe screws	10 Nm	
Cylinder head tightening torque		
Studs 1 st pass	30Nm	
2 nd pass	50Nm	
Nuts M6	10Nm	
Camshaft housing screws	18 Nm	
Chain tensioner screws	10 Nm	
Chain tensioner rack-and-pinion screws	10 Nm	
Cap on the central timing sprocket axis	20 Nm	
Crankshaft inspection stopper	8 Nm	
Distribution guide plate screws	10 Nm	•
Water pump housing screws	10 Nm	
Ignition flywheel nuts	80 Nm	•
Inner clutch hub nuts	100 Nm	•
Bellhousing freewheel nuts	120 Nm	•
Ignition cover screws	10 Nm	
Central crankcase screws	10 Nm	
Drum screws	10 Nm	
Oil pump screws	10 Nm	

CLEANING THE THROTTLEBODY

» Equipment

- Carburetor cleaner or Minerva brand universal cleaner.
- Open-end wrench 8.
- Socket screwdriver 7.
- Hex key 2,5.



» Removing the throttle body

- Remove the seat.
- Remove the fuel tank.
- Remove the clamps of the throttle body.
- Remove the cover of the spreader.
- Remove the throttle cable.
- Remove the body.

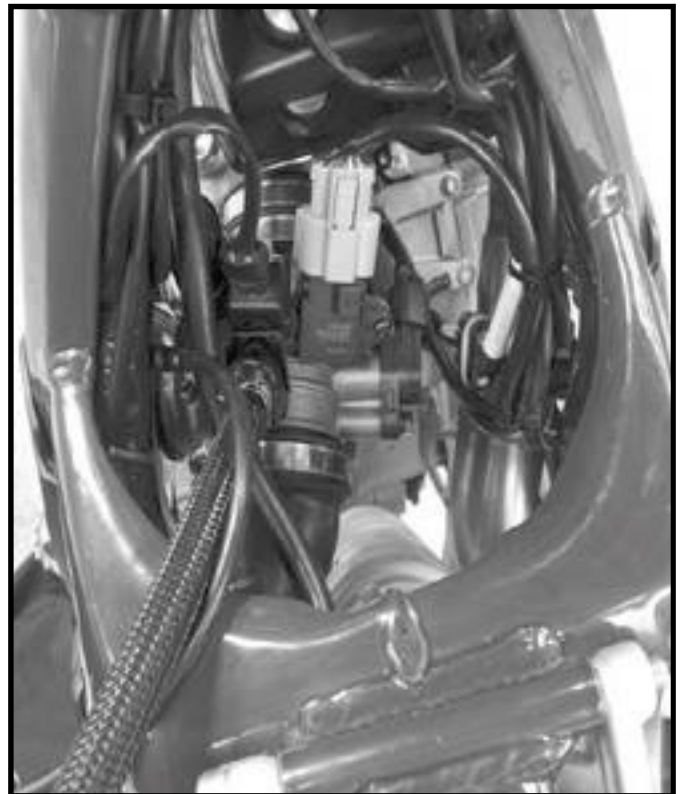

CLEANING THE THROTTLEBODY

- Unplug all connectors.
- Visually inspect.



- Clean with an universal cleaning solution.
- Blow.



CLEANING THE THROTTLEBODY

›| Cleaning the throttle body

- Clean the throttle body by means of a carburetor cleaner spray (Net Carbu).
- Be sure to clean the edge of the throttle valve on each side with the throttle fully opened.
- Clean the injector.
- Blow.



›| Installing the throttle body

Reassemble the parts following the reverse order of that of the removal, put **special connector** grease inside the connections (power injector, GST, etc.).

If you remove the inlet sleeve, pay attention to the direction!

- Adjust the clearance of the throttle cable.



- Disconnect the computer connector. Visually inspect the connectors.
- Clean with carburetor or universal cleaner.
- Blow.



- Apply **special connector** grease.
- Reconnect.



CHANGING THE TPS – THROTTLE POSITION SENSOR

The TPS of the throttle body monitors the position of the throttle. Its indexing is paramount to the proper functioning of the motorcycle. If you replace it, follow this procedure.

- Unscrew the screw (1) and remove the TPS.
- Position the new TPS and the screw (1) without tightening it.
- Connect the motorcycle and run the Exxotest diagnostic software (see procedure below).

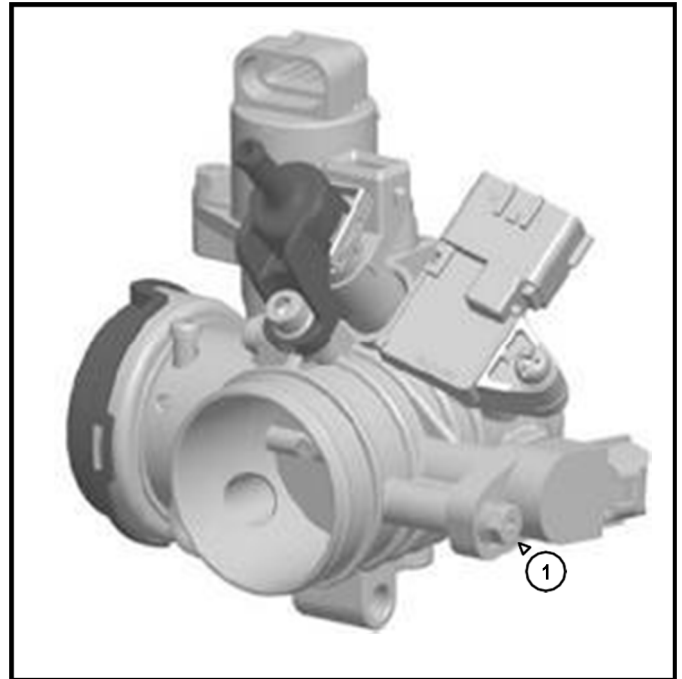

- Click on the Diagnostics menu logo



- Then click Sherco → M3C → Measuring parameters → Throttle position



- Adjust the sensor position by rotating it (see picture) until the displayed value is set to 0.5v +/- 0.05.

Once done, tighten the screw (1) to 4 Nm +/- 0.7.



INJECTION DIAGNOSTIC TOOL SYNERJECT

» 1- Presentation of the SYNERJECT injection system

1.1- Your Sherco 450/500 is equipped with a Synerject injection system consisting of an M3C calculator, a Ø42 mm throttle body, an ignition and a specific wiring harness.

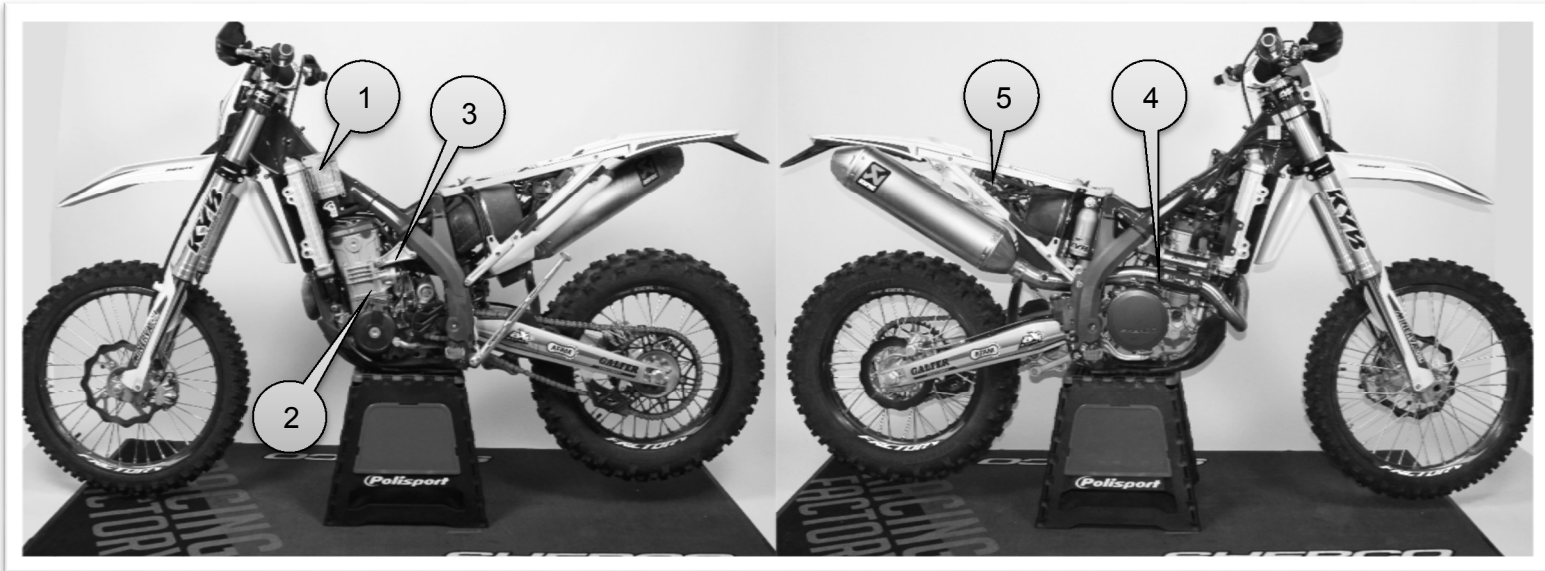

N°	Description	Location
1	Synerject M3C Calculator	Left side of the frame
2	Engine speed sensor (pick-up)	Upper part of the ignition cover
3	Synerject Ø42 mm throttle body	
4	Water temperature sensor	At the back of the cylinder head, on the right side
5	2-way sealed diagnostic connector (labeled "ECU")	At the rear side panel

INJECTION DIAGNOSTIC TOOL SYNERJECT

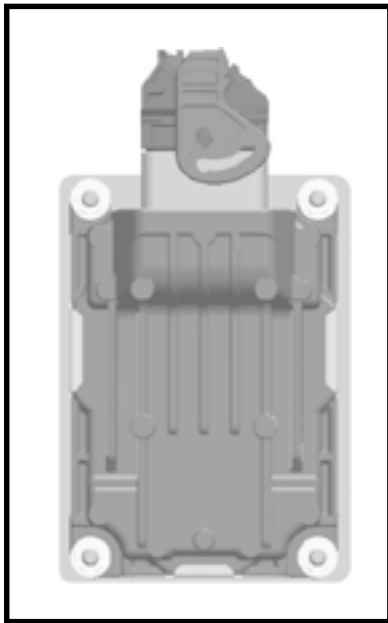

SynerjectM3C Calculator

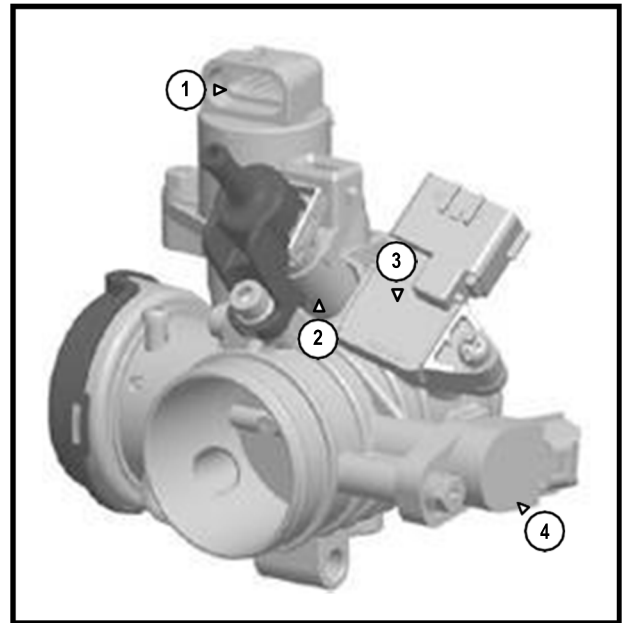

Synerject Ø42mm Throttle Body

N°	Description
①	Stepper motor (idle control and engine brake)
②	Injector
③	Temperature / pressure sensor (TMAP)
④	TPS : throttle position sensor

1.2- Exxodiag diagnostic description tool reference 4967

The diagnostic tool allows you to perform diagnostic operations, to update injection mapping and to verify certain information (serial number, operating hours, etc.).

1.3- Composition of the diagnostic tool

The case consists of a cable with a USB connector to MUX, a MUX device, a MUX cable to the motorcycle diagnostic connector, an installation CD, and a user manual.

INJECTION DIAGNOSTIC TOOL SYNERJECT

1.4- Diagnostic tool installation

In case of problem during the installation, please contact EXXOTEST at +33 (0)4 50 02 34 34 or by mail to courrier@exxotest.com.

A- Software and drivers installation :

- Open the installation CD on your computer.
- Run « Sherco_Setup ».

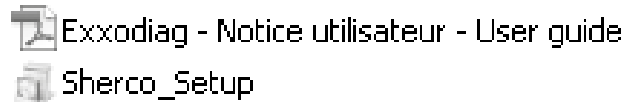

- Select the language.

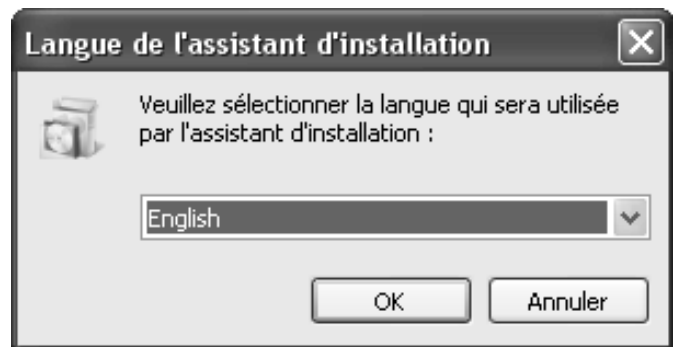

- Click on « Next ».



- Choose the installation folder.

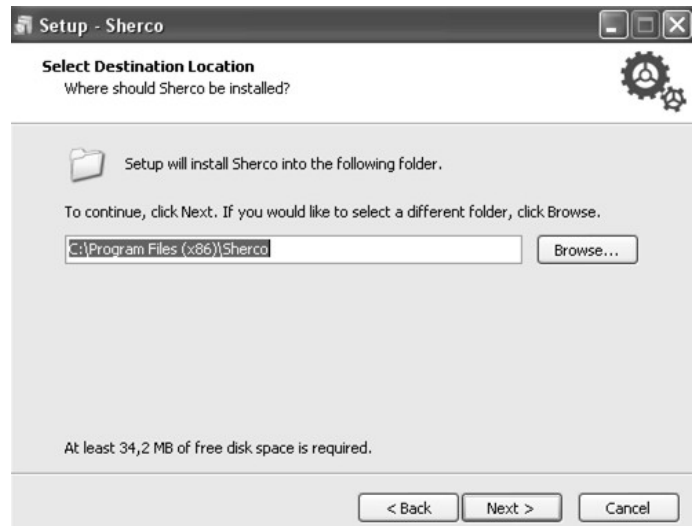

INJECTION DIAGNOSTIC TOOL SYNERJECT

- Click on « Next ».

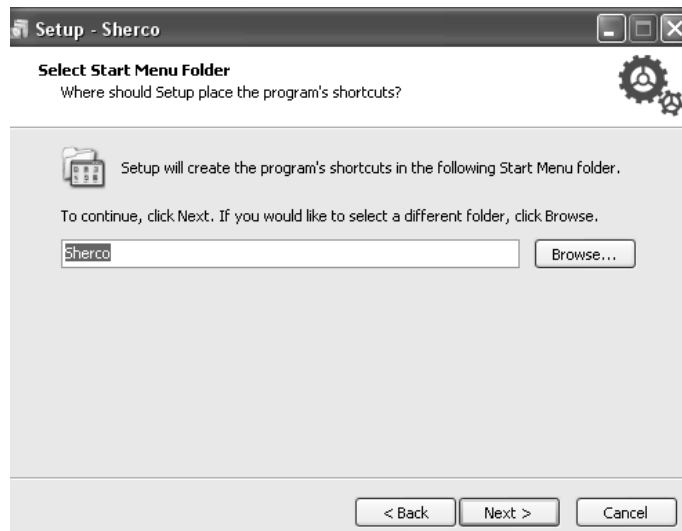

- Click on « Install ».

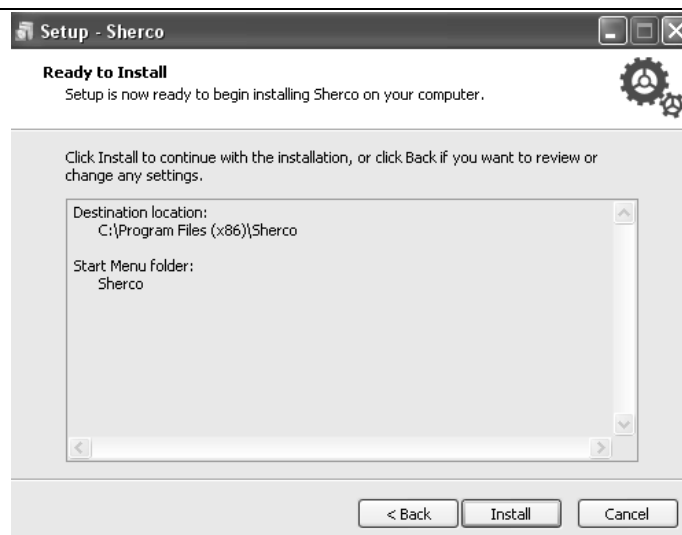

- Installation in progress.

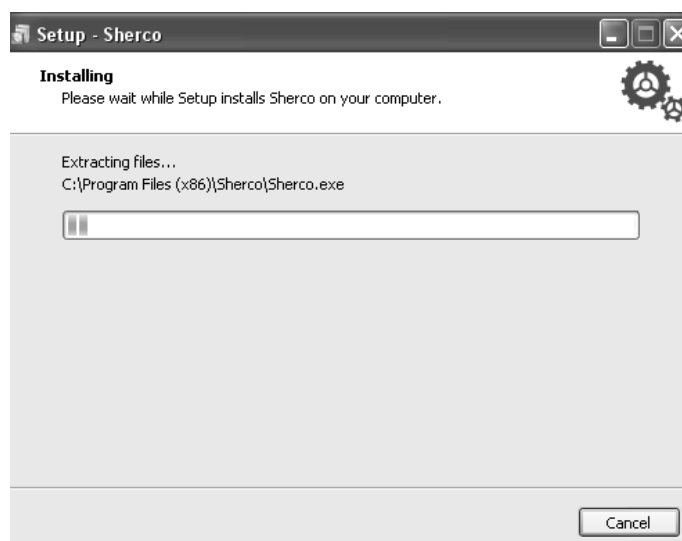

INJECTION DIAGNOSTIC TOOL SYNERJECT

- Check the box « Start the driver installation » and click on « Finish ».



- The following window will open. Read the terms of the license agreement. Check the box « I accept the terms of the license agreement » and click on « Install ».

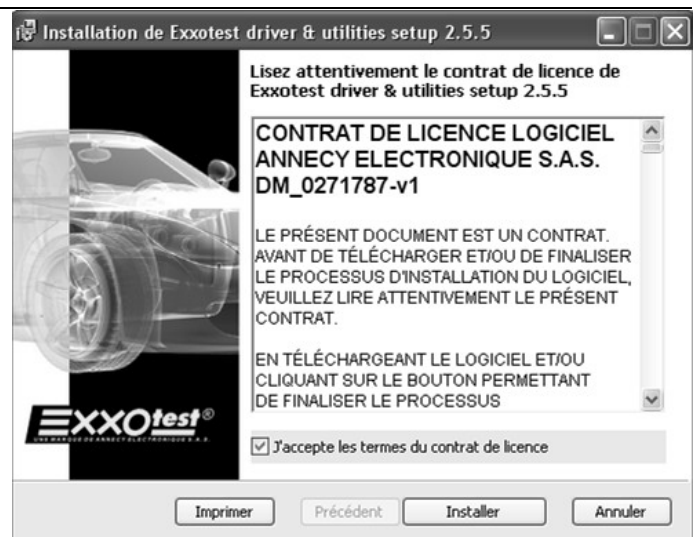

- Installation in progress.

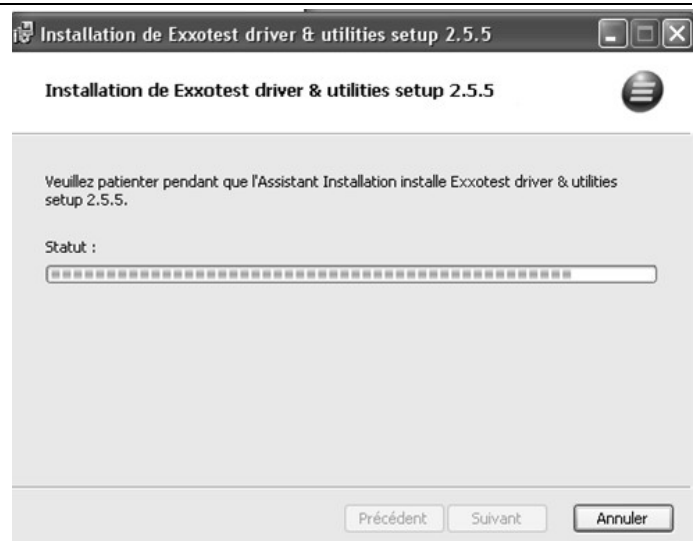

INJECTION DIAGNOSTIC TOOL SYNERJECT

- The following window will open. Click on « Finish ».

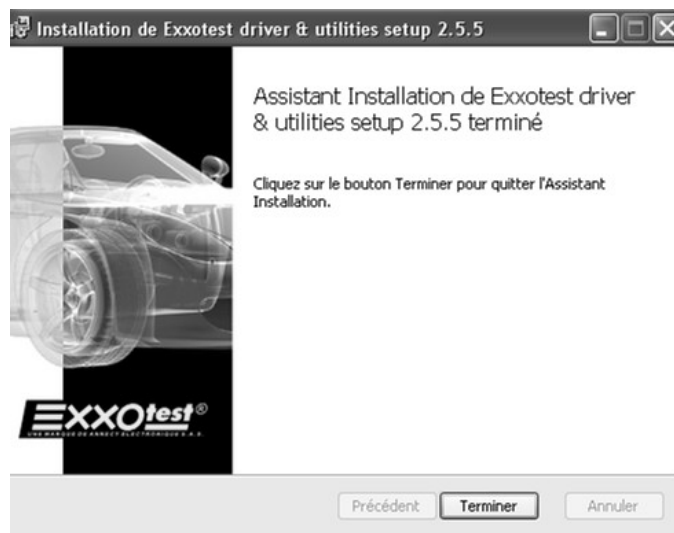

The installation is complete.

B- Connect the « MUXDIAG II » cable and its interface to a USB port on your computer.

Connect the cable to the diagnostic connector of the motorcycle.

Make sure the « MUXDIAG II » unit is properly powered by checking the LED :

- Solid blue: PC connection properly established.
- Flashing blue: communication with PC in progress.
- Blue off: no connection to the PC, or device in standby; it can also indicate a problem with the USB connector.
- Solid green: firmware issue.
- Flashing green (slow): firmware correctly run.
- Flashing green (fast): communication with PC in progress.
- Green off: no firmware.
- Solid red: correct power supply to the card.

- All LEDs OFF: the outlet is not powered on, or is off or USB in on standby mode.

» 2- Software overview

2.1- Connection with Keyless system

Sherco had a Keyless system on its motorcycles which allows the bike to switch on without any key and switch off automatically after 30seconds of non-use.

This last point blocks the diagnostic, this is why it is necessary to follow the steps down below before doing it.

1. Remove the plug (1) from the connector (2) (located on the rear sub frame – on the right part of the bike).

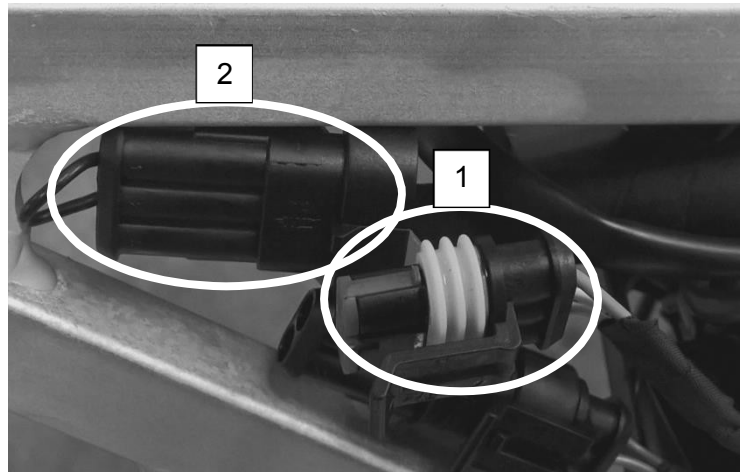
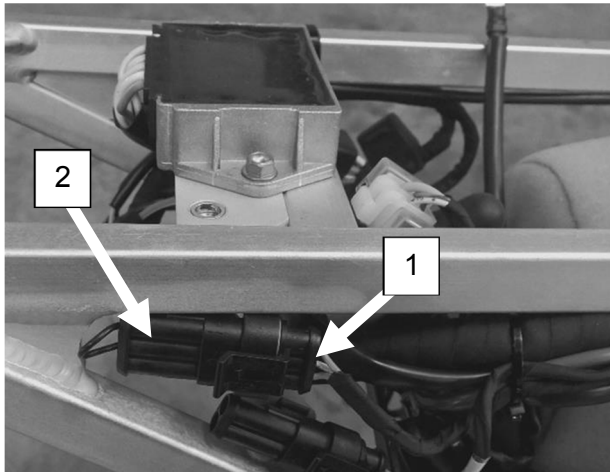

2. Take the shunt (3) (reference 6267) and connect the plug (1) into it.

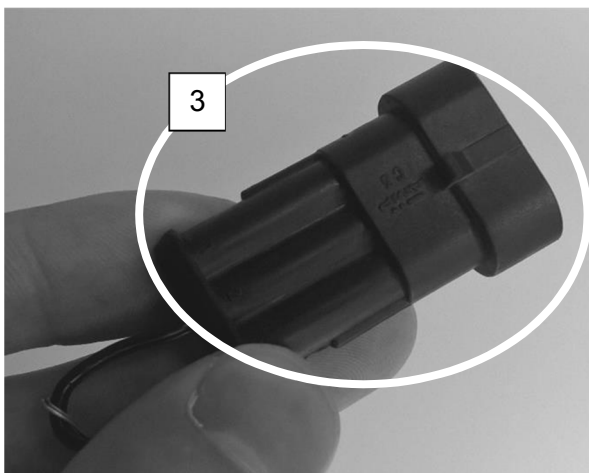

3. You can now do the diagnostic by following the next explanations.

INJECTION DIAGNOSTIC TOOL SYNERJECT

Information : to set up the connection with the motorcycle, the motorcycle must be switched on (On). To navigate through the different menus, the USB cable with the «MUXDIAG II» device only may be connected to the computer..

Run the software using the icon



The following menu will come up :



2.2- Software settings : configuration menu

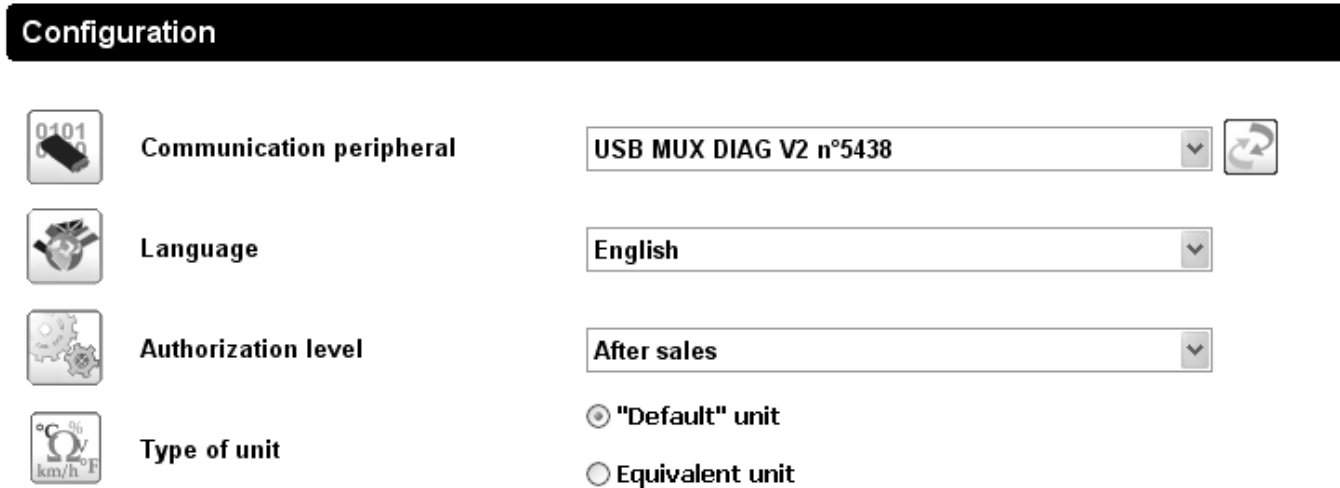

In this menu, you can modify :

- The diagnostic plug. You can refresh the list by hitting the button.  The number must match the number of the « MUXDIAG II » device.
- The languages available in the software: English, French, Spanish, Portuguese, German, Italian (the installation CD provided may not include all languages). Update the software-> page 53).
- Set the unit system.

- Click  to return to the home screen.

- Click  to save the changes.

2.3- Update menu and synchronization



A- In this menu, you can update the diagnostic software tool :

- To determine whether an update is available, check that you have an Internet connection, and then click on the following icon



- If an update is available, the following window will come up:



- If no update is available, the following message will come up:



INJECTION DIAGNOSTIC TOOL SYNERJECT

- Click on  to start downloading the update.



- The following message will come up :
- Click on  to start installation.



- Resume the installation process -> page 46. It is not necessary to restart the installation of the drivers.

INJECTION DIAGNOSTIC TOOL SYNERJECT

B- Configuration of Internet access parameters

It may be necessary to set up a proxy server to access the Internet.

- Click on 

- Fill in the following settings if necessary.

Configuration of proxy settings

- None
- Use the following settings

Customized settings

Address / Port	<input type="text"/>	<input type="text"/>
User	<input type="text"/>	
Password	<input type="text"/>	

- Click on  to save your changes.

3- Using the software



Diagnostic menu and injection mapping update



General :

- Click on « Sherco ».

Choose vehicle

 After sales	<input type="text"/>	<input type="button" value="Sherco"/>
 USB MUX DIAG V2 N°5438		

- Cliquez on « M3C ».

Choose ECU

 After sales	<input type="text"/>	<input type="button" value="M3C"/>
 USB MUX DIAG V2 N°5438		
 Sherco		

INJECTION DIAGNOSTIC TOOL SYNERJECT

- You reach the following menu:

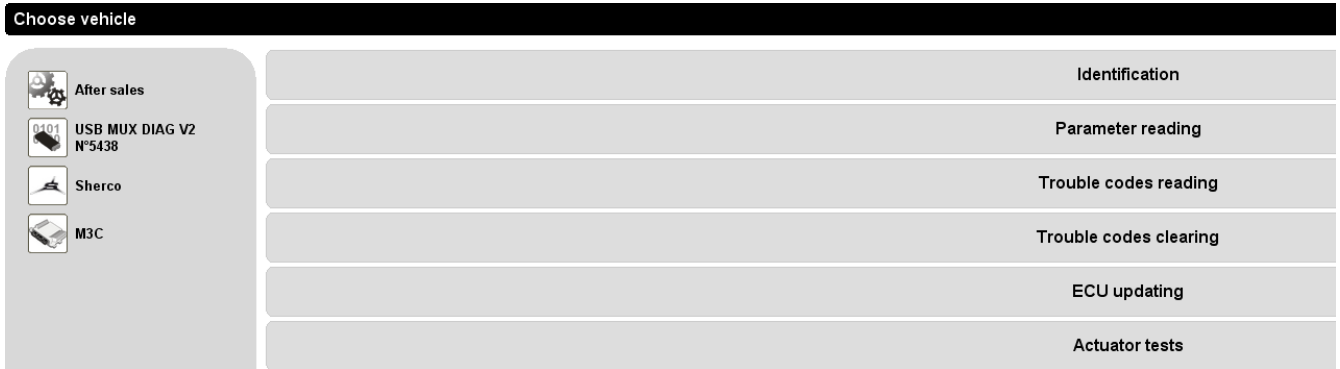

3.1- Identification : checking identification (serial number, vehicles operating hours calibration number).

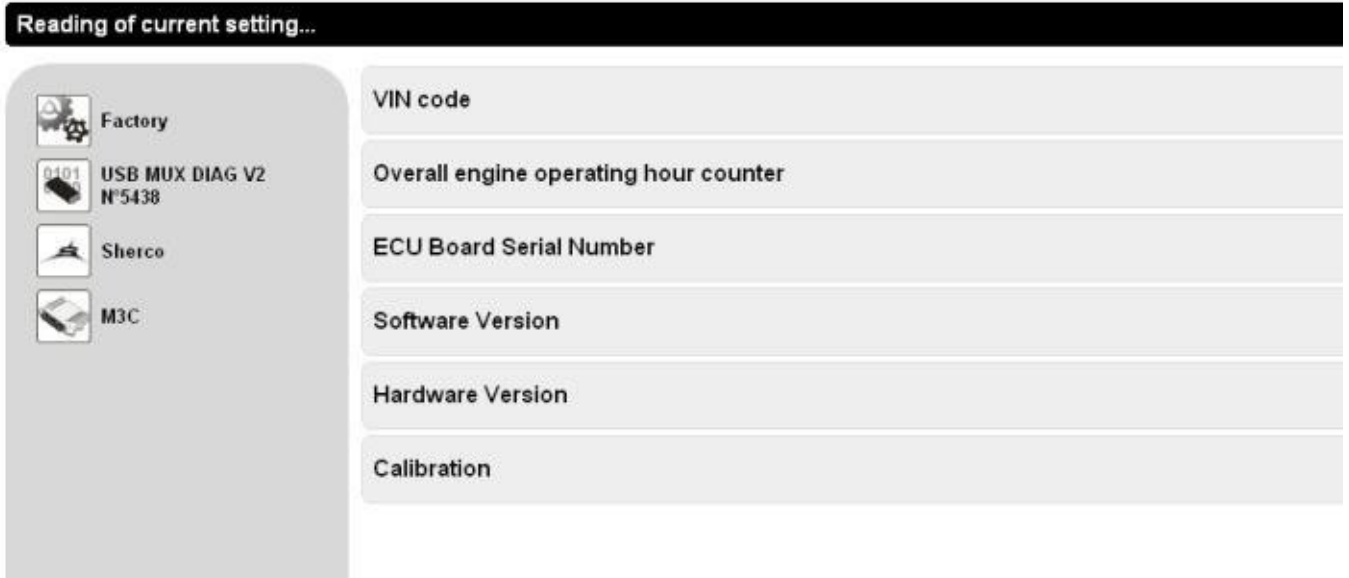

3.2- Measuring the parameters : general parameters (speed, pressure, stepper, etc).

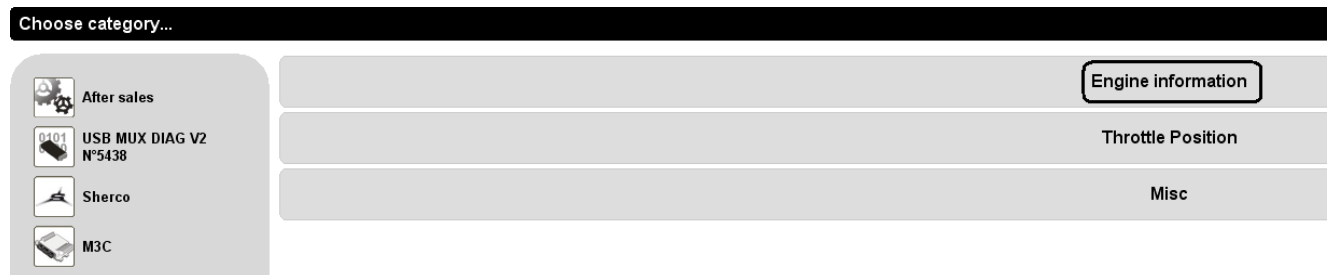





INJECTION DIAGNOSTIC TOOL SYNERJECT

A- Engine information:

- The main values of the system appear :

Reading of current setting...

 After sales	RPM	0 tr/mn
 USB MUX DIAG V2 N°5453	Engine Temperature	31 °C
 Sherco	Battery Voltage	11.9 V
 M3C	Air temperature	28 °C
	Ambient pressure	1012 mb
	Stepper position	0
	Throttle position	0 %

Details :

- Stepper Position : valeur d'ouverture de la valve d'air (stepper)-> 35 < 50 < 75.
Too weak value : for example , valve leak/engine air intake.
Too high value : dirty injection body.

Information : correct value of the air valve: motor at 80 °C after being operated for 15 m and idle for 2 m.

- Throttle position : engine stopped value : 0%. Maximum opening : 100%.
If the value is not equal to 0% when the engine is off, it means that adaptation has not been made:
Reboot the system several times (Switch off ignition. Wait until the relay slap calculator makes a clacking sound. Switch the motorcycle back on). The step equals 0.5%.
- State Stop button: state of the emergency stop button. 0: disabled, 1: enabled.
- Engine status: ES (engine ready to start), ST (engine starts), IS (idle regime), PL (acceleration), PU (deceleration), PUC (cut injection deceleration).

B- Other values are displayed in the windows :

Throttle position :

- Adaptation value to the minimum position of the throttle valve (V): $0.45 < 0.5$ (nominal value) < 0.55 .

Miscellaneous :

- Intake pressure (mb): pressure at the nozzle body measured by the TMAP sensor.
- State motor synchronization: recognition of the engine cycle.
 - 0: not phase motor.
 - 1: phased running motor.
- Adaptive on the whole idle speed controller (%): function not activated.

3.3- Error codes :

When you click on « Read the error codes », the system starts checking.

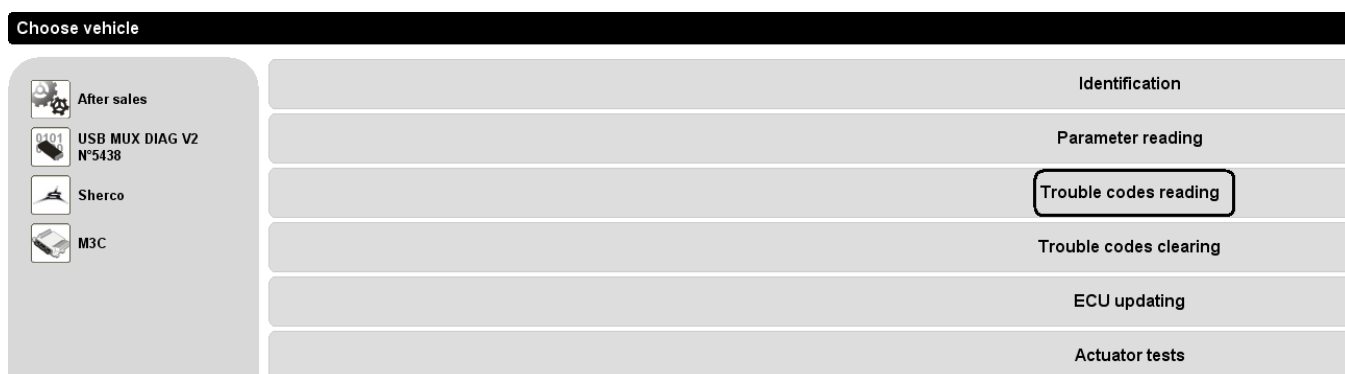

- If no error appears, exit the menu via the icon





INJECTION DIAGNOSTIC TOOL SYNERJECT

If errors occur :



Breakdown list...

 After sales

 USB MUX DIAG V2
N°5438

 Sherco

 M3C

 **Fugitive failure** Permanent failure 

 Throttle Position Sensor (P0122)

 Electric fuel pump (P0231)

 Air pressure sensor (P0107)

 Intake air temperature sensor (P0113)

 Stepper motor (P1508)

 Cooling fan (P0485)

You can get the details of the error by clicking on the error displayed :

Details of breakdown code...

 After sales

 USB MUX DIAG V2
N°5438

 Sherco

 M3C

 **Throttle Position Sensor (P0122)**

Short circuit to ground or overload

- Number of occurrence of present failure = 59
- RPM = 0 tr/mn
- Engine Temperature = -40 °C
- Battery voltage = 4.0 V
- Air Temperature = 29 °C
- Ambient pressure = 64 mb
- Applied Ignition angle = -29 °CRK
- Injection Time = 35 ms
- Engine state = ES
- Overall engine operating counter = 0 h
- Engine operating minute counter since last engine start = 237 min
- Throttle Position in degrees = 0 °TPS
- Intake manifold air pressure = 1360 mb
- Mass air flow = 40 mg/tdc
- Adaptive value of integral term of the idle speed controller = -50.00 %

- Record errors and exit the menu via the icon



Info :

- 1- Transient failure/permanent failure: a transient error becomes permanent after a variable number of engine cycles according to the component (injector, fuel pump, etc.). For a permanent error to disappear, wait 40 motor cycles without the issue reappearing.
- 2- Fan error: if there is no fan installed on the motorbike, there will always be a fan error alarm (P0485).

3.4- Clearing error codes :

A – If errors occur, go to the « Clearing Error Codes » menu.

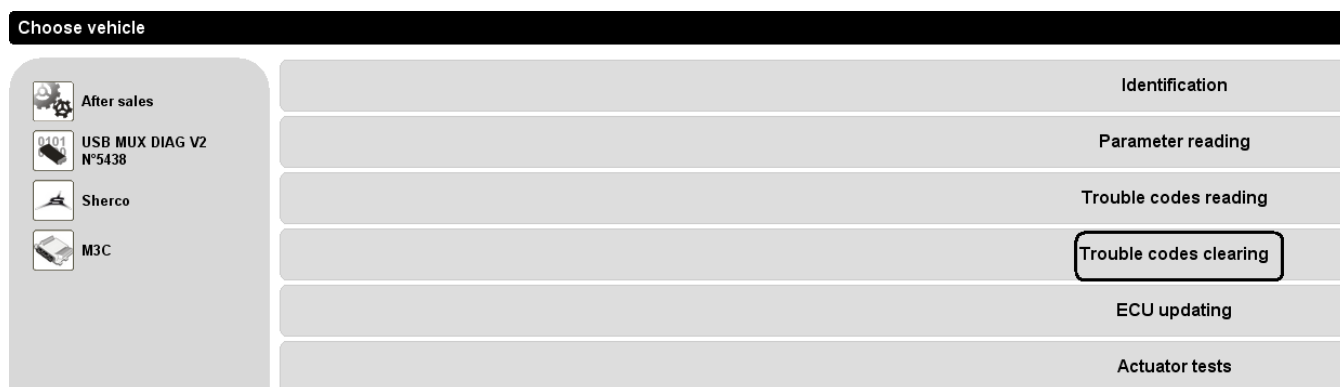

Clear all Diagnostic Trouble Codes ?

- Confirm deletion of error codes via the icon



The following tab is displayed :

Current service in execution...

- Confirm with the icon

B – Return to the « Reading error codes » menu :

Choose vehicle





Identification
Parameter reading
Trouble codes reading
Trouble codes clearing
ECU updating
Actuator tests

- Check that the errors detected are identical. Verify/change the defective parts. Verify the connections.



3.5- Actuators testing

In addition to reading the error codes, you can test certain components of the system:

Choose actuator test...

 After sales	Ignition coil
 USB MUX DIAG V2 N°5438	Injector
 Sherco	Fuel pump
 M3C	Cooling Fan
	Stepper motor



 

A – Ignition coil

When the ignition coil test is launched, the following message appears :

Warning previous to service launching...

 After sales



 USB MUX DIAG V2 N°5438

 Sherco

 M3C

 No diag nor failure detection while engine is stopped.
Check that coil make a noise.



The system is not able to detect a motor coil failure when the engine is off. Whether the coil is defective or not, the test result will be the same. Therefore, verify that the coil emits a characteristic sound of a proper operation during the testing process.

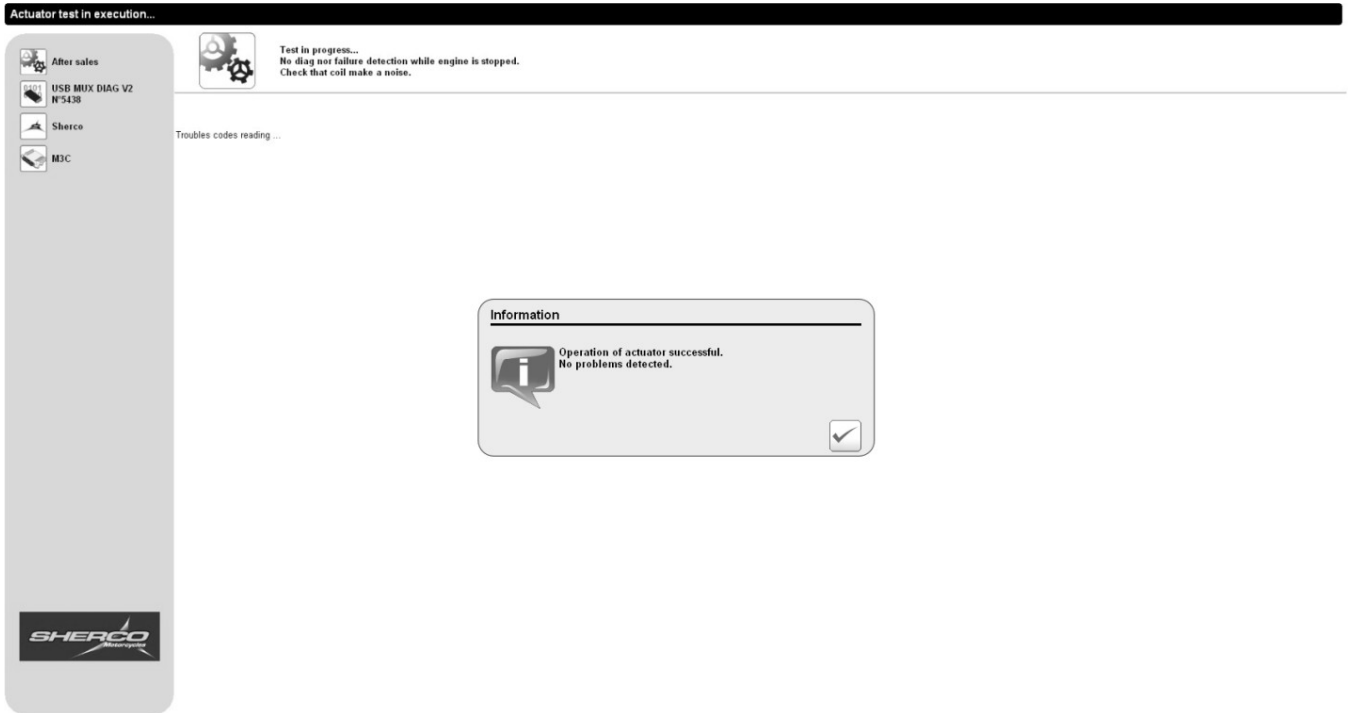

B - Injector

Same type of test as for the coil. Check that the injector emits a clacking sound on activation.

C – Fuel Pump / Fan / Stepper

For the fuel pump, fan and stepper (air valve), it is a « standard » test, and the notification process of errors or proper operation is conventional.

INJECTION DIAGNOSTIC TOOL SYNERJECT

Example of proper operation stepper :

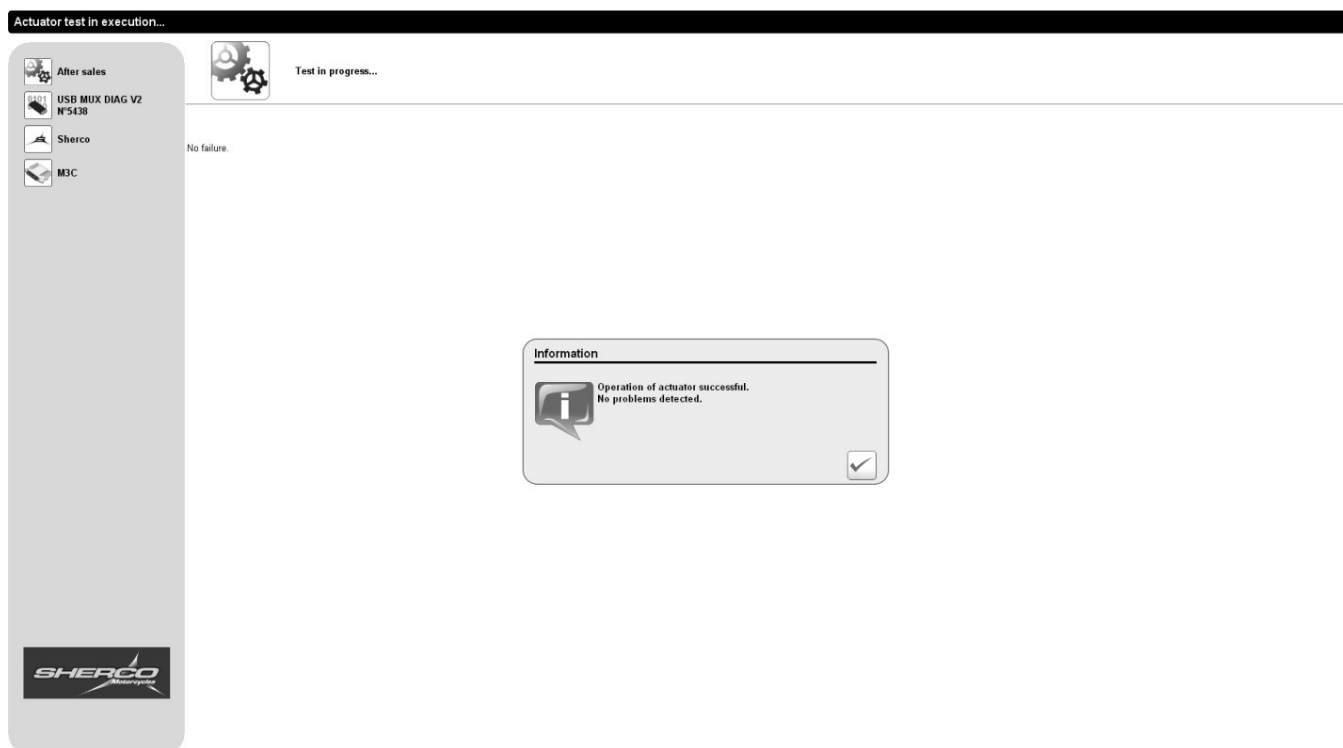

Stepper error :

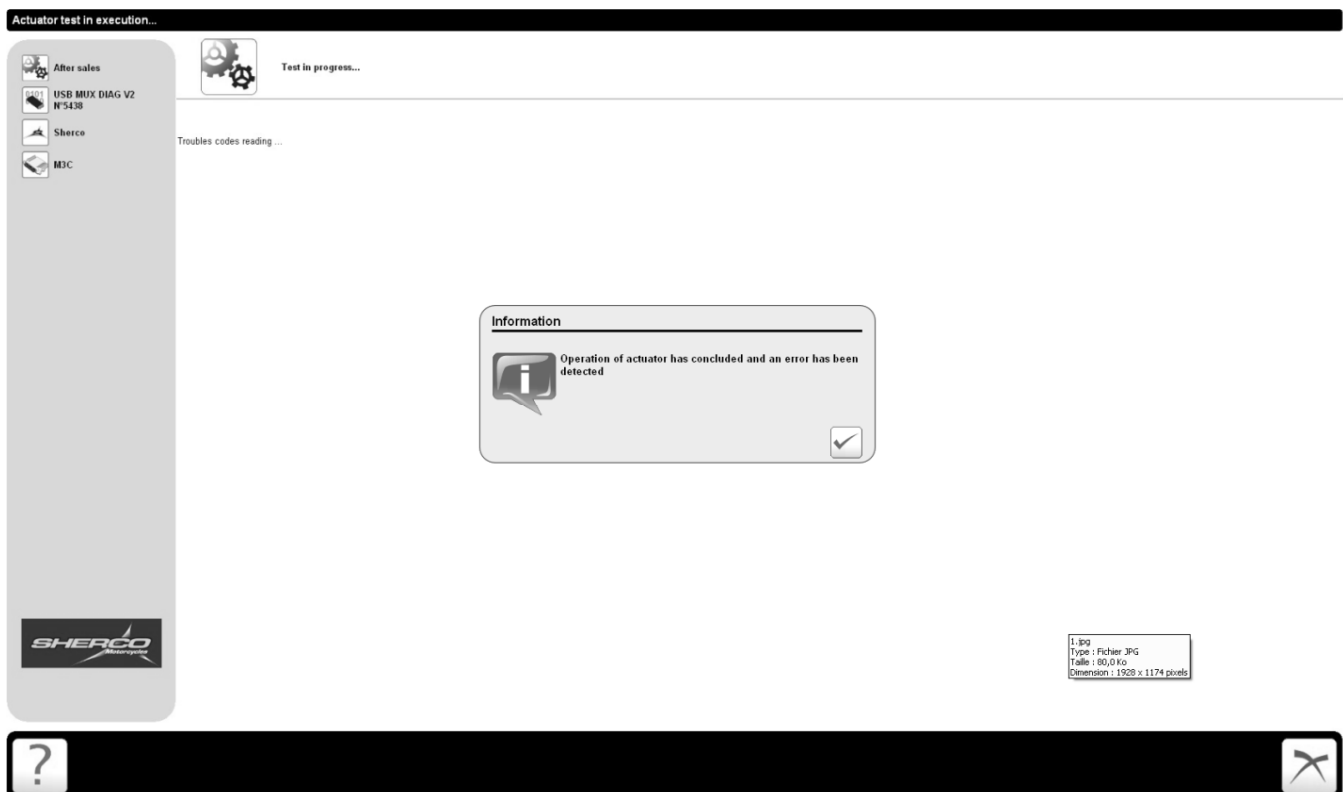

If an error is notified, check/replace defective parts.

Information : the fan test makes sense only if a fan is installed on the bike.

INJECTION DIAGNOSTIC TOOL SYNERJECT

3.6- Updating the calculator

With the diagnostic tool, it is possible to update the engine mapping (calibration). For a racing silencer for example, or because an update was proposed by the manufacturer.

These files will be available for free on sherconetwork.

In case of any doubt, contact technical support.

1 – Download the needed update (file : .mot).

ShercoNetwork → Information → Technical Information → Injection map

Pay attention to **the model year, the cylinder capacity, silencer type, etc.**

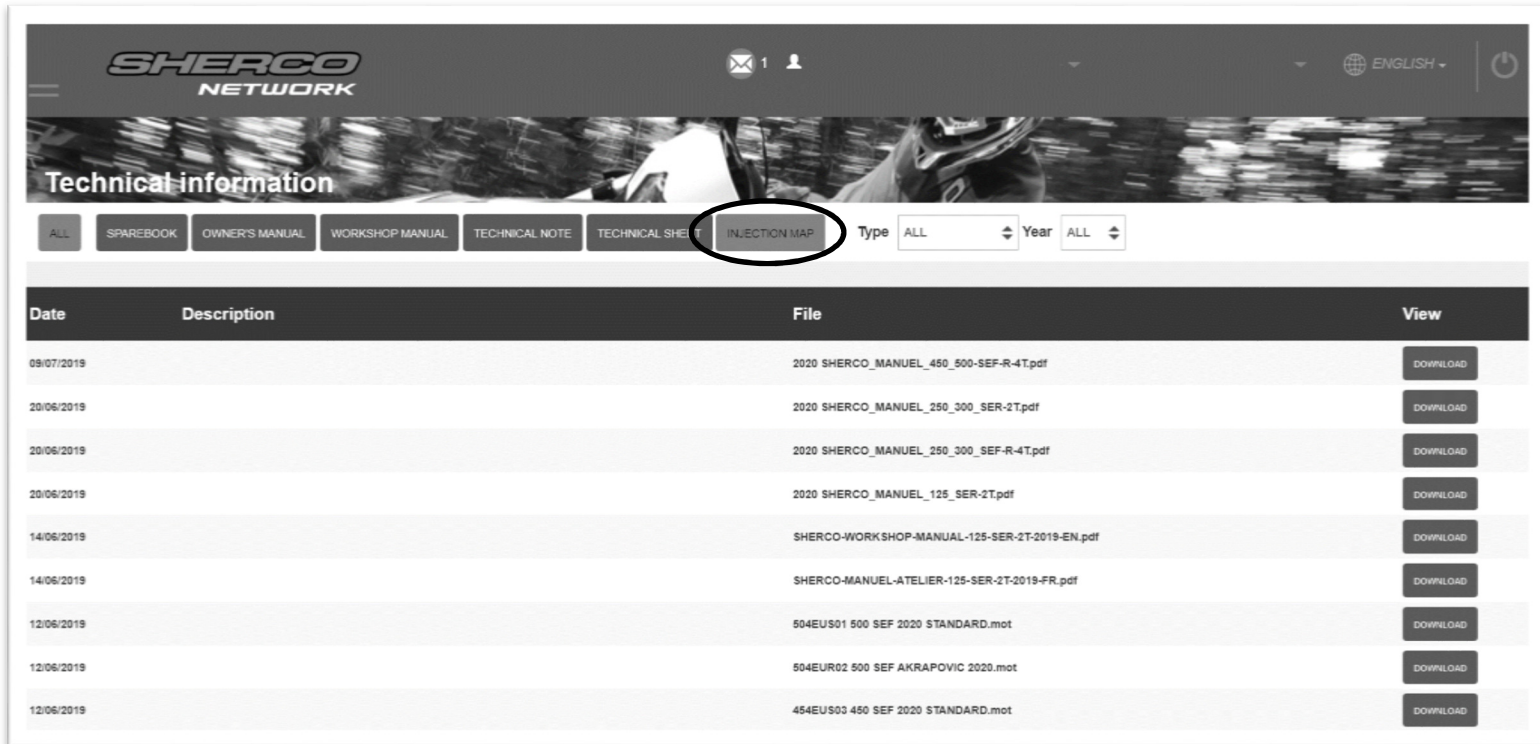

Date	Description	File	View
09/07/2019		2020 SHERCO_MANUEL_450_500_SEF-R-4T.pdf	DOWNLOAD
20/06/2019		2020 SHERCO_MANUEL_250_300_SER-2T.pdf	DOWNLOAD
20/06/2019		2020 SHERCO_MANUEL_250_300_SEF-R-4T.pdf	DOWNLOAD
20/06/2019		2020 SHERCO_MANUEL_125_SER-2T.pdf	DOWNLOAD
14/06/2019		SHERCO-WORKSHOP-MANUAL-125-SER-2T-2019-EN.pdf	DOWNLOAD
14/06/2019		SHERCO-MANUEL-ATELIER-125-SER-2T-2019-FR.pdf	DOWNLOAD
12/06/2019		504EU501 500 SEF 2020 STANDARD.mot	DOWNLOAD
12/06/2019		504EUR02 500 SEF AKRAPOVIC 2020.mot	DOWNLOAD
12/06/2019		454EU503 450 SEF 2020 STANDARD.mot	DOWNLOAD

2 – Turn On the motorbike .

3 – Click on Update calculator.



Choose vehicle	Identification
After sales	Parameter reading
USB MUX DIAG V2 N°5438	Trouble codes reading
Sherco	Trouble codes clearing
M3C	ECU updating
	Actuator tests

INJECTION DIAGNOSTIC TOOL SYNERJECT



Update ECU now ?

Confirm with the icon



Select the calibration file (.mot) previously downloaded and click on Open.

4- The file is being updated.



Downloading ... (14.2%)

WARNING!

DO NOT TURN OFF THE MOTORCYCLE DURING THE DOWNLOAD OPERATION (FLASH),
DO NOT INTERRUPT THE SOFTWARE ABRUPTLY DURING THE FLASH.
RISK OF PERMANENT DAMAGE TO THE COMPUTER

5 - Upon completion of the download, the fuel pump starts up and the following message appears:

INFORMATION : download successful

Confirm with the icon





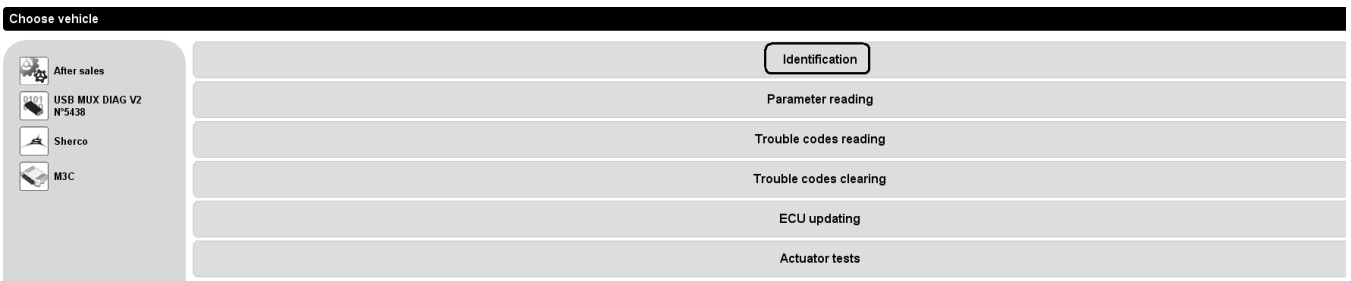

6-Check the correct allocation of the calibration file by selecting « Identification ».



Check that the file name matches the downloaded file.

INJECTION DIAGNOSTIC TOOL SYNERJECT

Lecture des paramètres en cours...

 Usine	Numéro de série du véhicule (VIN)	BS630E3DB003296
 USB MUX DIAG V2 N°5453	Compteur temps d'utilisation moteur	0.0 h
 Sherco	N° de série du calculateur	2011980210
 M3C	Version logicielle	QR010010
	Version matérielle	S180037040Z9
	Calibration	25EUS01.





- Information:** the information on serial number and operating hours are not reset during a calibration update.
- 7-Put back the “shunt” on the connector in the air filter box to switch back on “keyless” mode.
 - 8-the ECU power latch will proceed during 20 s.
 - 9-wait 30 s until the ECU stop before starting the bike.
 - 10-start the bike, stop it and wait 30 s before to restart the bike.
 - 11-Switch on the bike and verify that the parameters of the motor are normal (idle, steeper opening, ect.)

3.7- Print screen function



When liaising with technical support, and in order to allow rapid identification of potential problems, you can attach to your message screen print files with the F10 key of your keyboard.

The «Identification» tab is definitely important for good communication (serial number of the bike, engine hours, calibration, etc.).

Reading of current setting...

 Factory	VIN code	VNBS430E32B001821
 USB MUX DIAG V2 N°5438	Overall engine operating hour counter	0.0 h
 Sherco	ECU Board Serial Number	2011929783
 M3C	Software Version	QR010010
	Hardware Version	S180037040Z9
	Calibration	25EUS01.



CHECKING THE CHARGING CIRCUIT

1 – Static control values (engine off) 450/500.

Battery voltage > 12.5V.

A – Stator windings resistance values :



Y1-Y2	0.44Ω±10%
Y2-Y3	
Y1-Y3	

B – Resistance of the engine speed sensor : 117Ω±10%

Check that there is no continuity between the windings and the mass of the motorbike.

2 –Dynamic control values:

Engine speed sensor :

1.7V MIN/300 RPM.

120V MAX/10000 RPM.

Tension regulator :

Alternative (AC 200V caliber).

Idle : 22V ±2V.

At 6000 RPM : 77V±3V.

Direct :

On regulator output (DC 20V caliber).

At 4000 RPM :14.6V + Red/White,- Green.

CHECKING THE CHARGING CIRCUIT

Alternator :

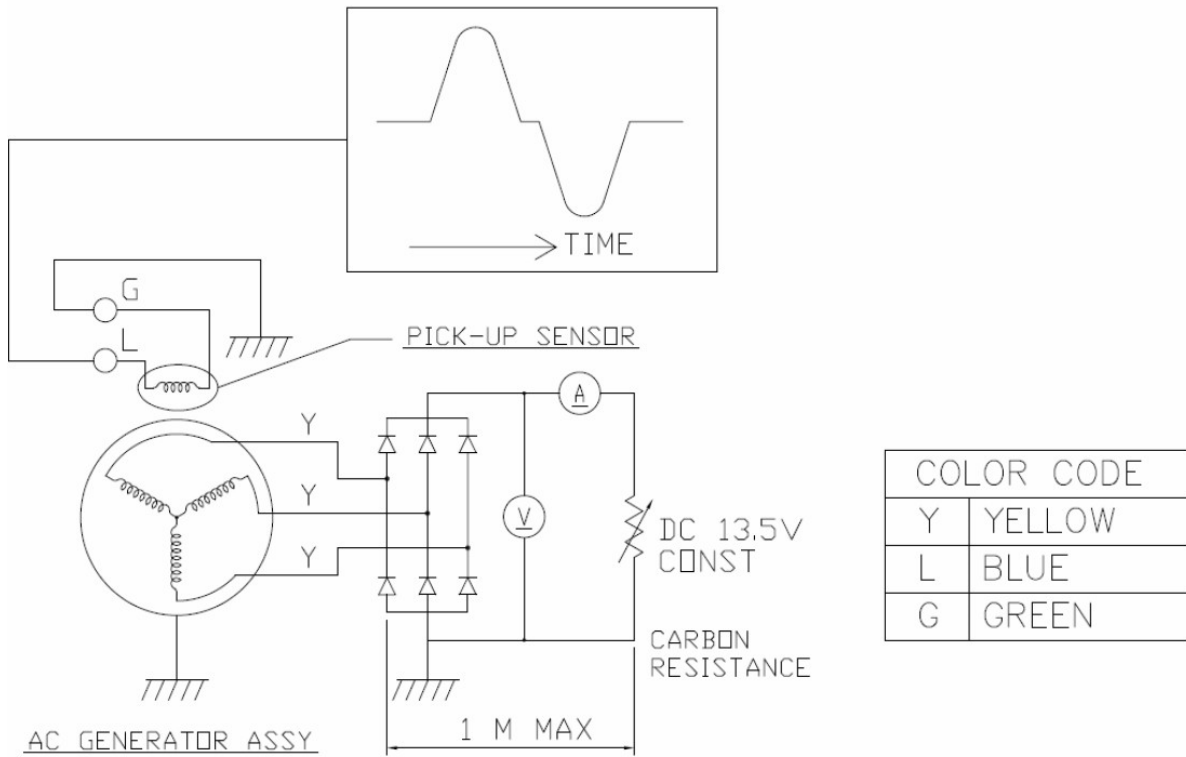

Tolerance values = -5% /+10%.

RPM	Voltage (AC)	Current (IB) (DC)	VB
2000	35V	7.2A	DC 13,5V
2500	43V	11.3A	
3000	50.5V	13.6A	
4000	63V	15.6A	
5000	75.5V	16.5A	
6000	88V	16.9A	
7000	99.5V	17.2A	
8000	112V	17.4A	
9000	125.5V	17.5A	
10000	137V	17.6A	

CONTROL OF THE SENSORS

1- Control of the TPS sensor

1. Remove the injector body from the bike.

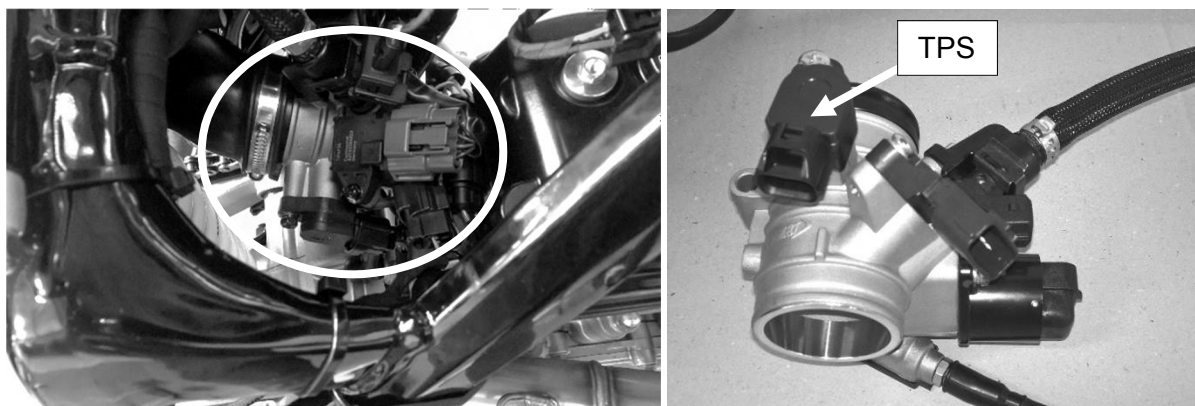

2. Control the resistance of the TPS as done below.



3. Values (in kΩ).

Butterfly closed :

Between + (red) and – (black) : 5 +/- 0.5

Between signal (blue) and – (black) : 1.25 à 1.55

Between signal (blue) and + (red) : 5.3 +/- 0.5

Butterfly fully open :

Between + (red) et – (black) : 5 +/- 0.5

Between signal (blue) et – (black) : 4.6 +/- 0.4

Between signal (blue) et + (red) : 2.05 +/- 0.3

CONTROL OF THE SENSOR

2- Values of temperature sensor

TEMP (°C)	RESIST (K Ω)
-40	100.950
-30	53.100
-20	29.121
-10	16.599
0	9.750
+10	5.970
+20	3.747
+25	3.000
+30	2.547
+40	1.598
+50	1.150
+60	0.746
+70	0.565
+80	0.377
+90	0.275
+100	0.204
+110	0.153
+125	0.102

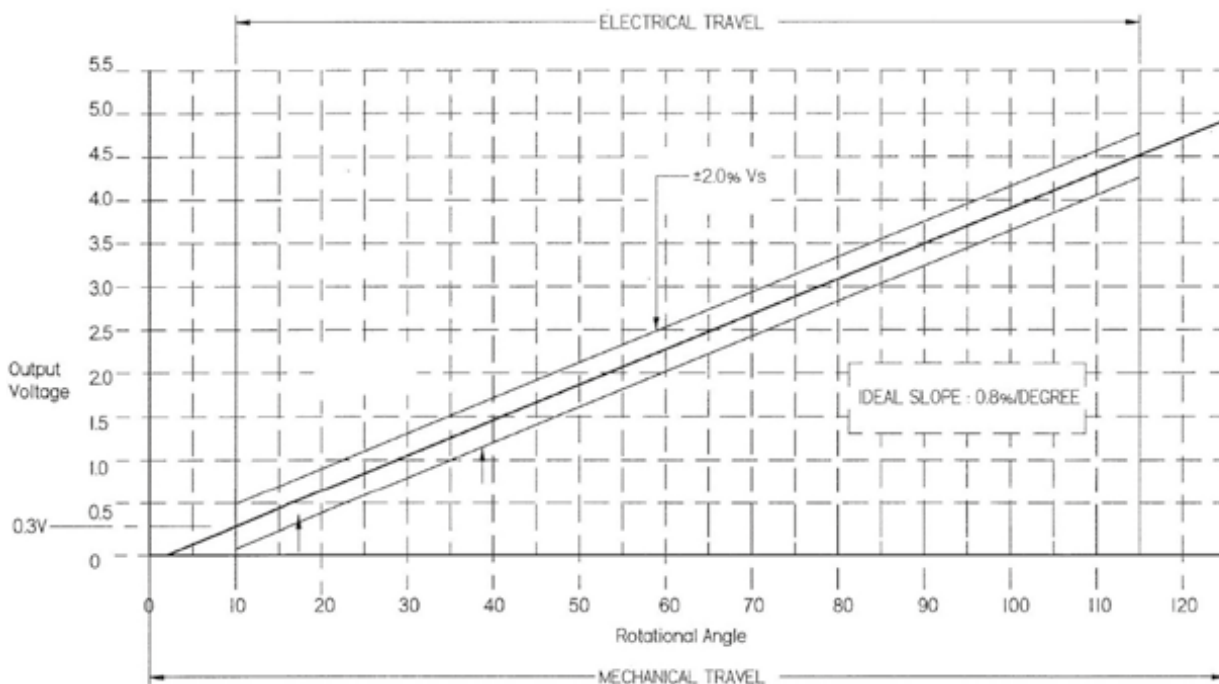

Injection wiring harness

	Connectors description
002	Light harness connector
1010	Electrical starter
1020A	Pick up sensor
1020B	Generator
1020C	Regulator
1042	General Relay
1135	Bobine HT
1211A	Fuel pump
1211B	Dashboard
1225	Stepper motor
1290	TPS sensor
1303	ECU relay
1310	TMAP sensor
1320	ECU
1330	Injector
1510	Fan harness connector
4020	TCO sensor
8235A	Electrical starter relay (relay)
8235B	Electrical starter relay (battery)
8235C	Electrical starter relay (motor)
8235D	Electrical starter relay motor
9901	Double mapping
9902	Emergency stop
C001A	Diagnostic connector
C001B	Diagnostic connector
C001C	Diagnostic connector plug
Fusible	Fuse 15A
MM01	Engine ground
BB00A	+ Battery
BB00B	- Battery

WIRING DIAGRAM

Geometry

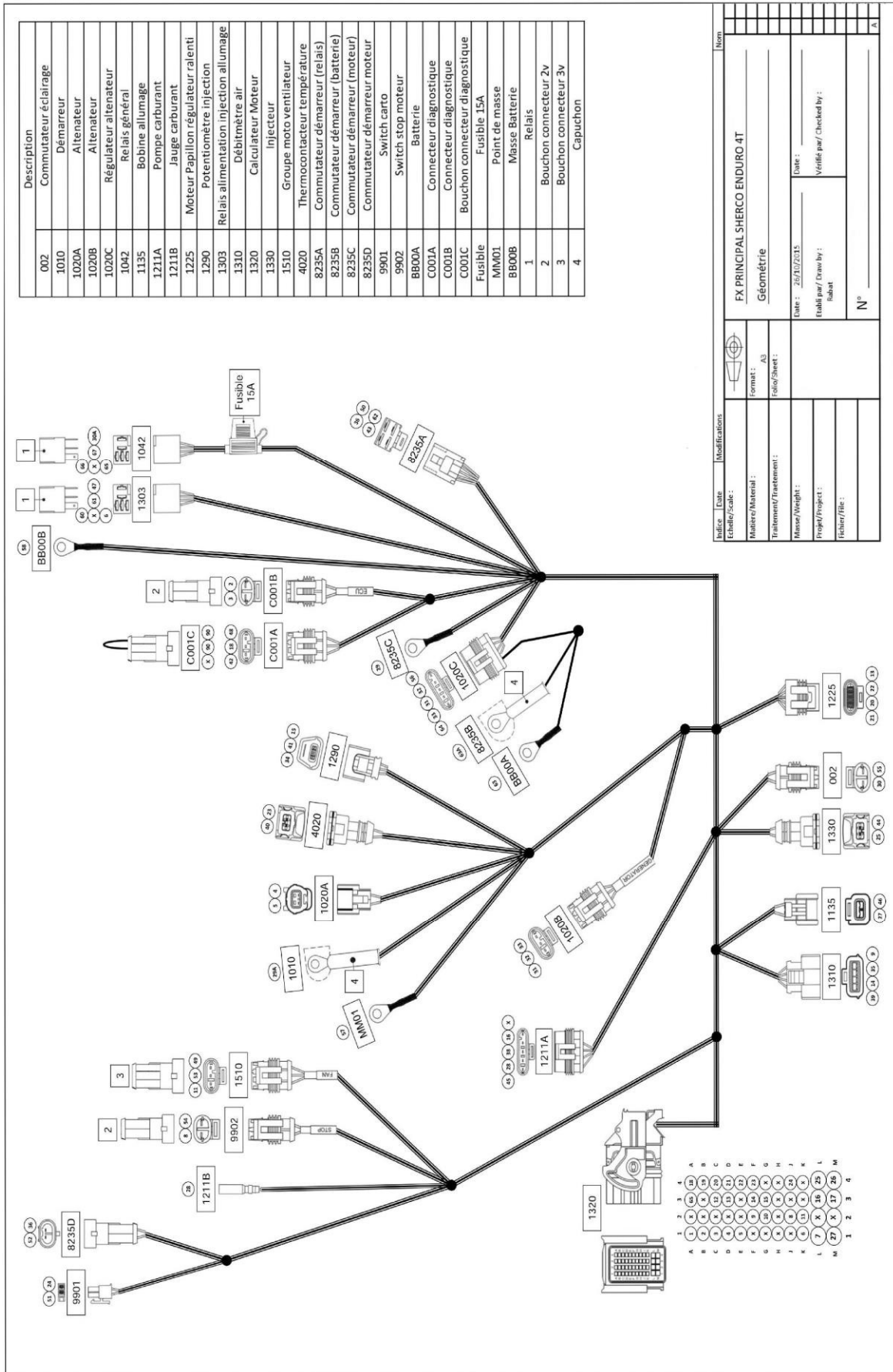

WIRING DIAGRAM

Light wiring harness 450/500SEF

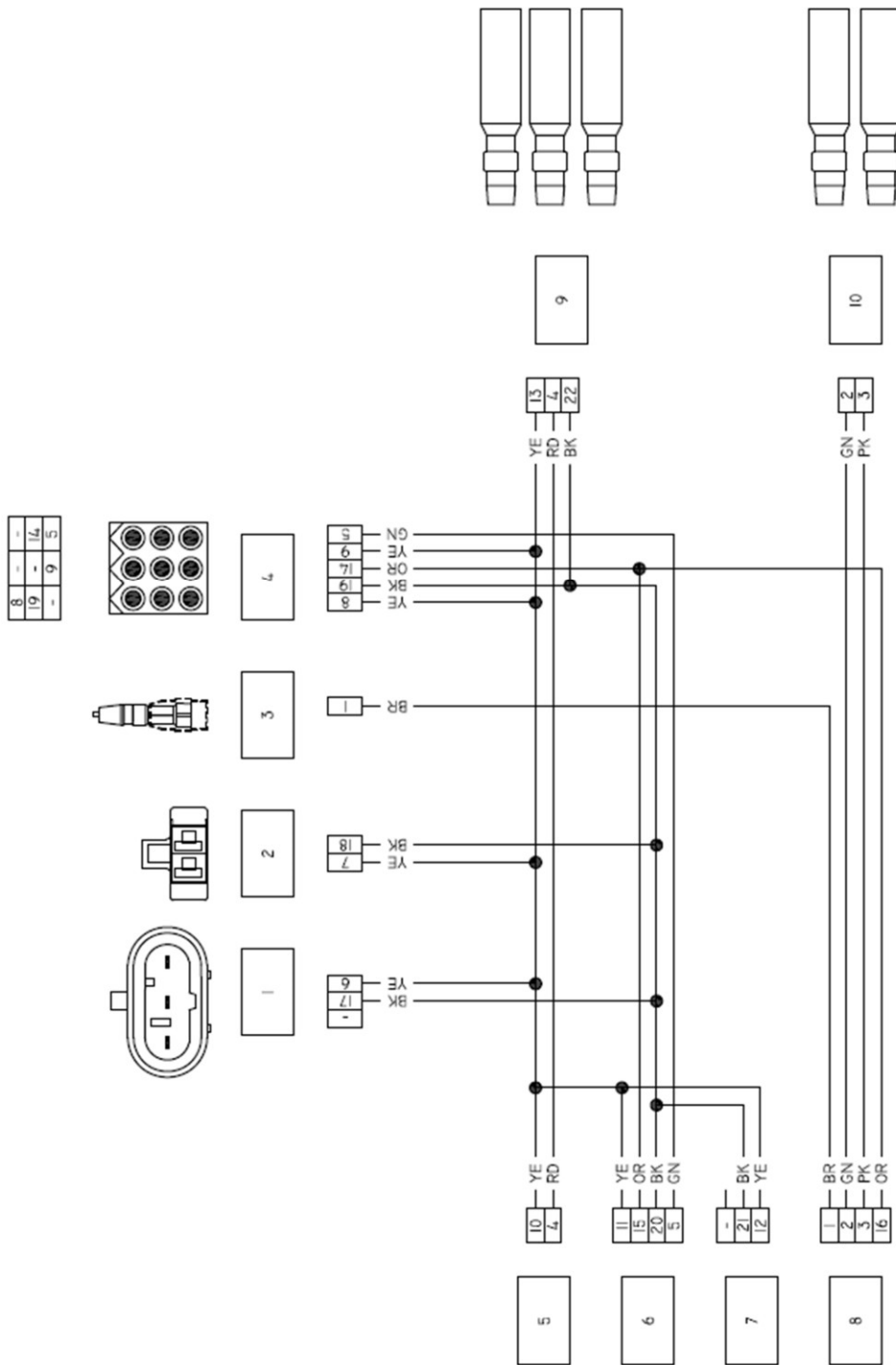

COLOR CODE	
RD	RED/ROUGE
YE	YELLOW/JAUNE
BU	BLUE/BLEU
WH	WHITE/BLANCHE
GN	GREEN/VERT
BK	BLACK/NOIR
BR	BROWN/MARRON
GY	GREY/GRIS
OR	ORANGE/ORANGE
VI	VIOLET/VIOLET
PK	PINK/ROSE

WIRING DIAGRAM

Light wiring harness Racing 450/500 SEF

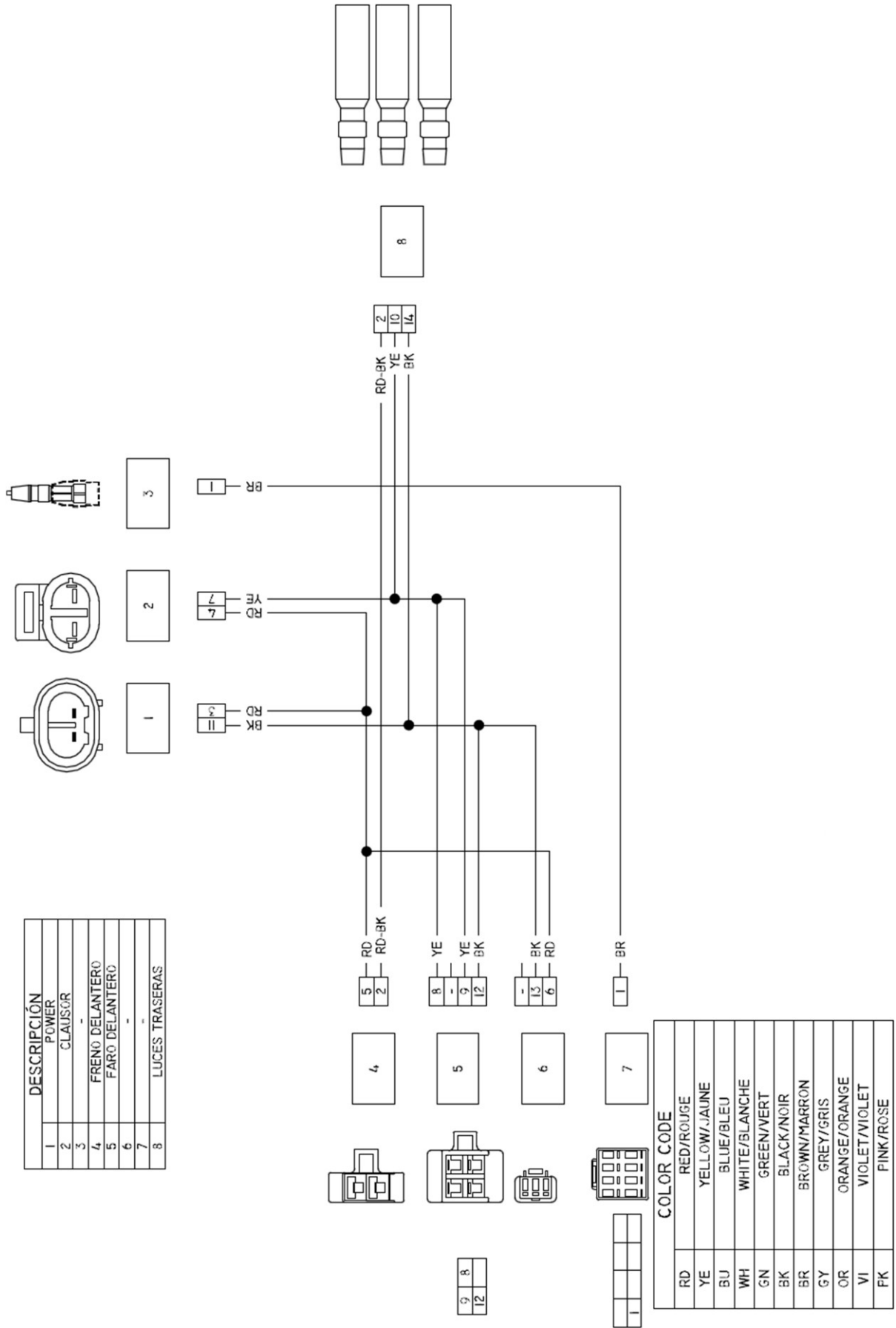

WIRING DIAGRAM

Accessories wiring harness

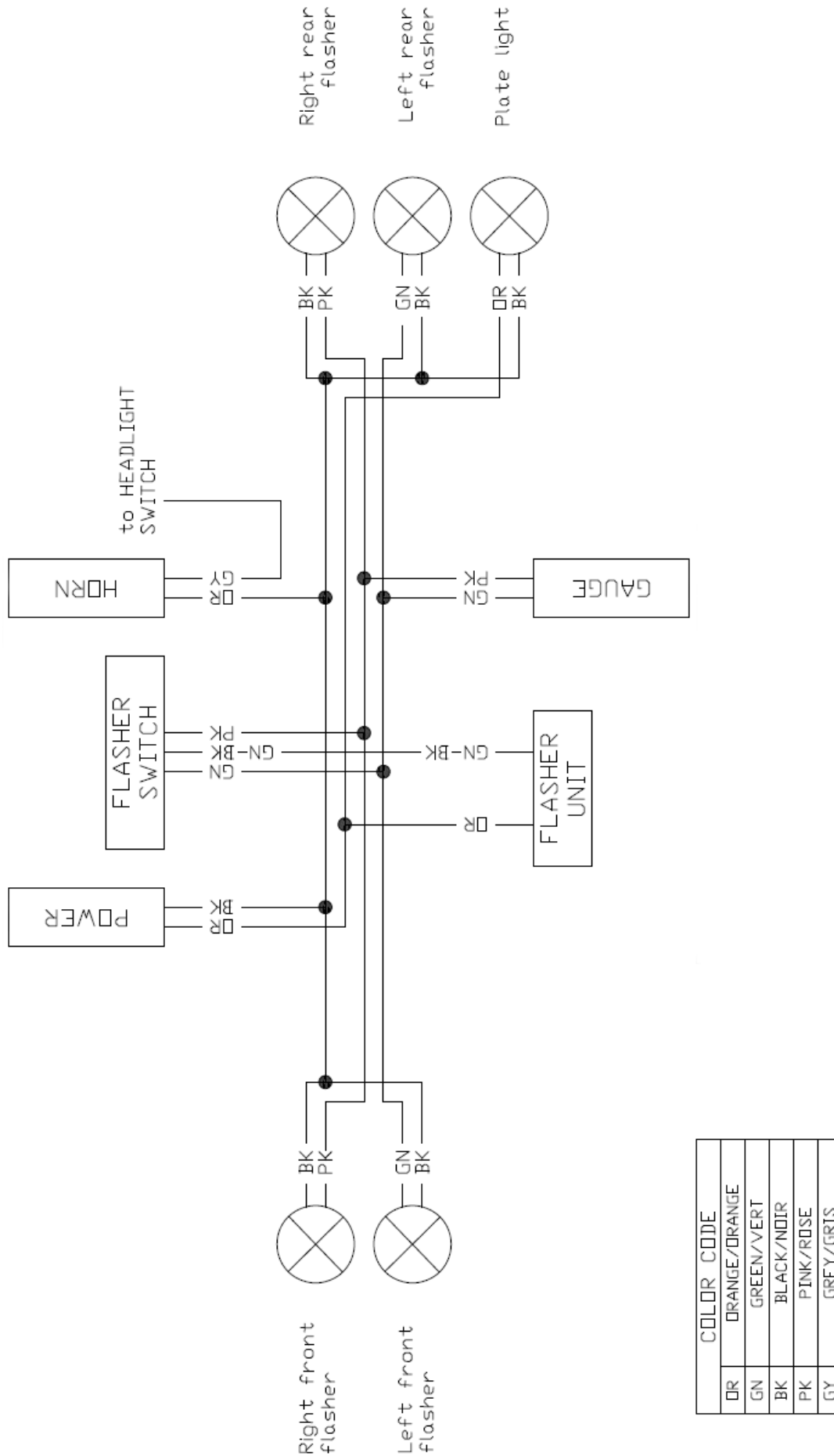

WIRING DIAGRAM

Fan wiring harness

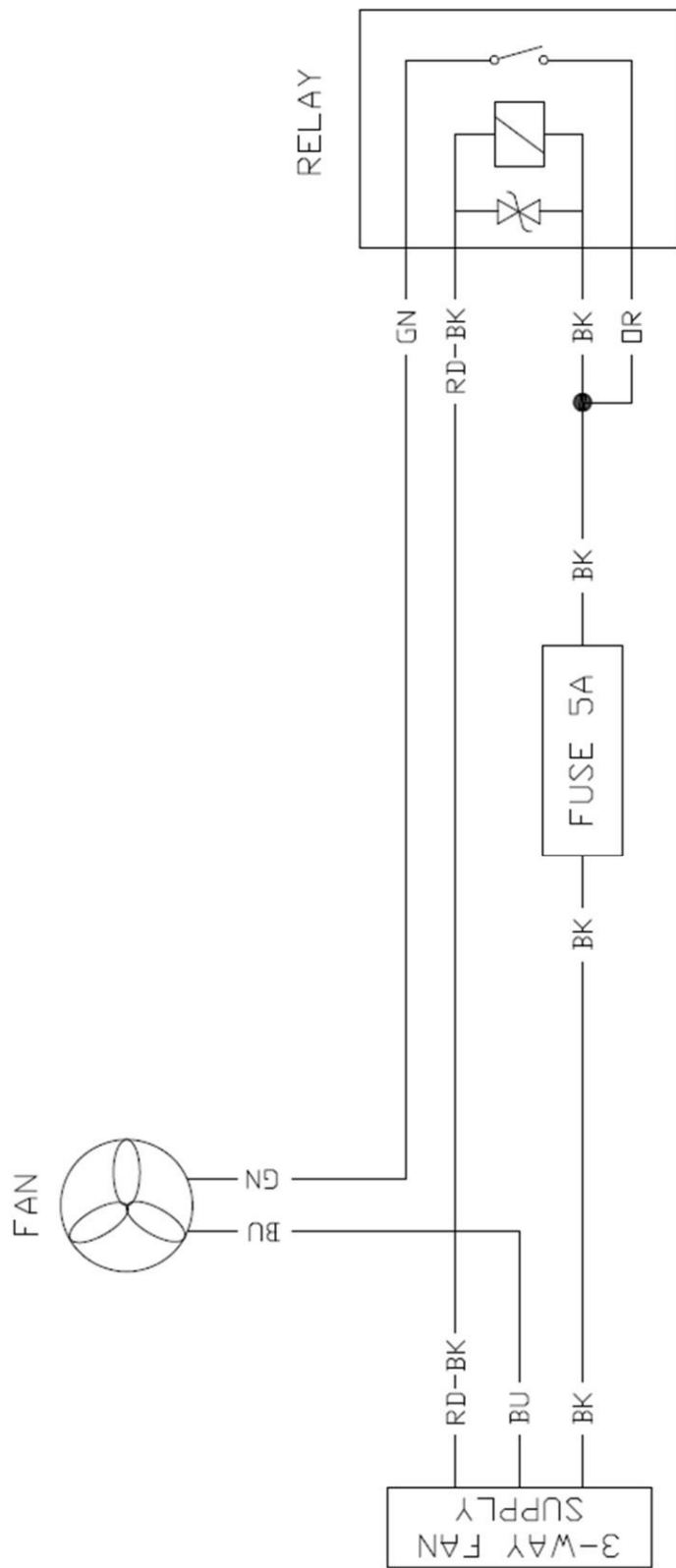

COLOR CODE	
RD	RED/ROUGE
BU	BLUE/BLEU
GN	GREEN/VERT
PK	PINK/ROSE
BK	BLACK/NOIR
OR	ORANGE/DRANGE

SHERCO

WWW.SHERCO.COM

