

AUTOMATIC TRANSMISSION

| | Page |
|---|--------|
| TROUBLESHOOTING | AT-2 |
| ATF INSPECTION | AT-5 |
| ADJUSTMENTS | AT-5 |
| ELECTRIC CONTROL | AT-6 |
| STALL TEST | AT-22 |
| TIME LAG TEST | AT-23 |
| HYDRAULIC TEST | AT-24 |
| ROAD TEST | AT-25 |
| OPERATING MECHANISM FOR EACH GEAR | AT-29 |
| AUTOMATIC SHIFT DIAGRAM | AT-30 |
| ON-VEHICLE REPAIR | AT-32 |
| REMOVAL OF TRANSMISSION | AT-42 |
| DISASSEMBLY OF TRANSMISSION | AT-45 |
| COMPONENT GROUP DISASSEMBLY, INSPECTION AND ASSEMBLY | AT-51 |
| Oil Pump..... | AT-52 |
| Overdrive Input Shaft and Clutch..... | AT-55 |
| Overdrive Case and Brake..... | AT-60 |
| Front Clutch..... | AT-63 |
| Rear Clutch..... | AT-67 |
| Center Support Assembly | AT-69 |
| Planetary Gear Output Shaft | AT-75 |
| Transmission Case and Rear Brake Pistons | AT-80 |
| Valve Body | AT-83 |
| Extension Housing | AT-103 |
| Torque Converter..... | AT-103 |
| Electrical Parts | AT-104 |
| ASSEMBLY OF TRANSMISSION | AT-105 |
| INSTALLATION OF TRANSMISSION | AT-116 |

TROUBLESHOOTING

GENERAL NOTES

1. Troubles occurring with the ECT can be caused by either the engine, ECT electrical control or the automatic transmission itself. These three areas should be distinctly isolated before proceeding with troubleshooting.
2. Troubleshooting should begin with the simplest operation, working up in order of difficulty, but initially determine whether the trouble lies within the engine, electrical control or transmission.
3. Proceed with the inspection as follows:

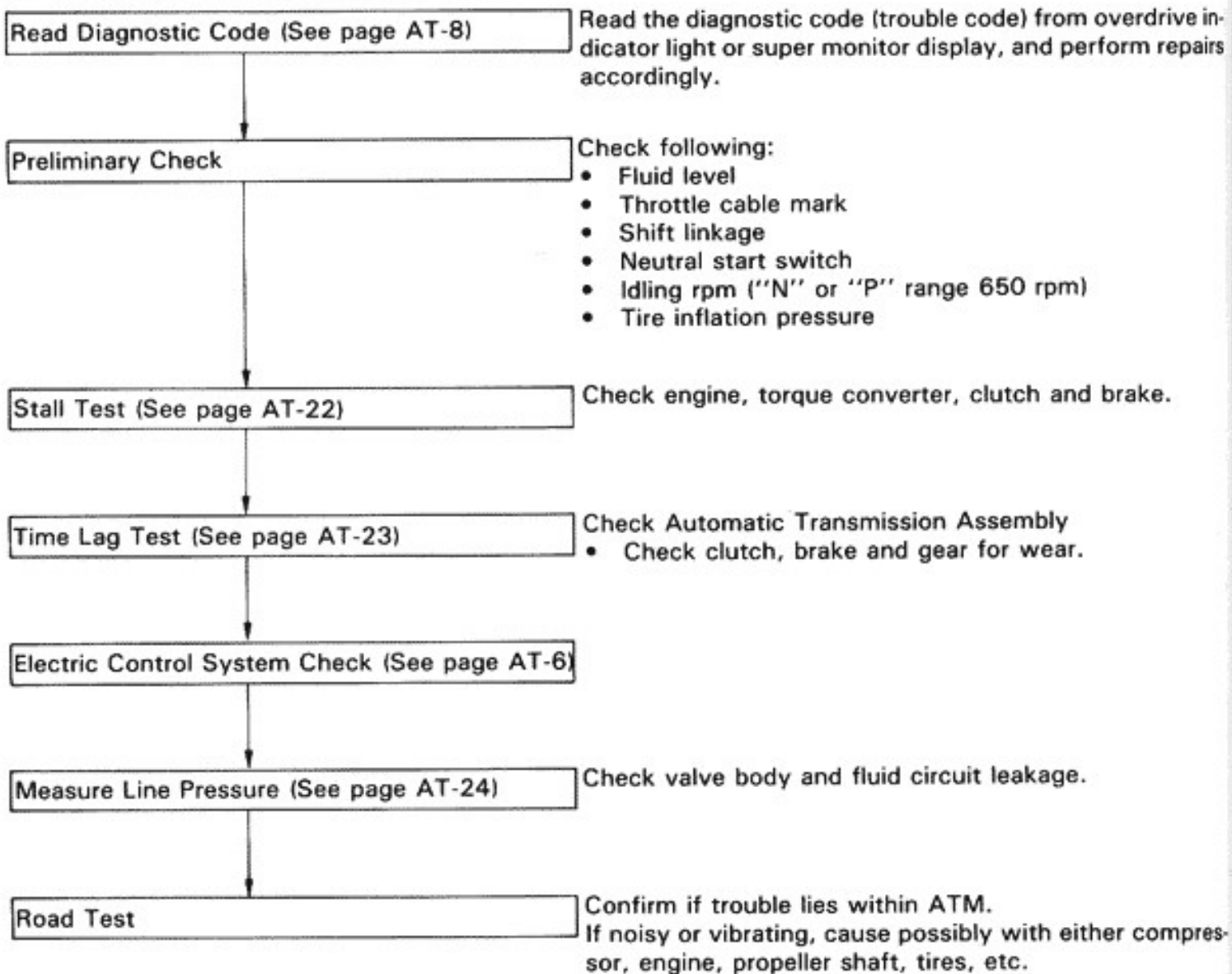

TROUBLESHOOTING (Cont'd)

| Problem | Possible cause | Remedy | Page |
|--|---|--|---|
| Fluid discolored or smells burnt | Fluid contaminated Torque converter faulty Transmission faulty | Replace fluid Replace torque converter Disassemble and inspect transmission | MA-10 AT-103 AT-45 |
| Vehicle does not move in any forward range or reverse | Manual linkage out of adjustment Valve body or primary regulator faulty Park lock pawl faulty Torque converter faulty Converter drive plate broken Oil pump intake screen blocked Transmission faulty | Adjust linkage Inspect valve body Inspect park pawl Replace torque converter Replace drive plate Clean screen Disassemble and inspect transmission | AT-5 AT-83 AT-37 AT-103 AT-44 AT-28 AT-45 |
| Shift lever position incorrect | Manual linkage out of adjustment Manual valve and lever faulty Transmission faulty | Adjust linkage Inspect valve body Disassemble and inspect transmission | AT-5 AT-83 AT-45 |
| Harsh engagement into any drive range | Throttle cable out of adjustment Valve body or primary regulator faulty Accumulator pistons faulty Transmission faulty | Adjust throttle cable Inspect valve body Inspect accumulator pistons Disassemble and inspect transmission | AT-5 AT-83 AT-112 AT-45 |
| Delayed 1-2, 2-3 or 3-OD up-shift, or down-shifts from 4-3 or 3-2 then shifts back to 4 or 3 | Electric control faulty Valve body faulty Solenoid valve faulty | Inspect electric control Inspect valve body Inspect valve body | AT-6 AT-83 AT-83 |
| Slips on 1-2, 2-3 or 3-OD up-shift, or slips or shudders on take-off | Manual linkage out of adjustment Throttle cable out of adjustment Valve body faulty Solenoid valve faulty Transmission faulty | Adjust linkage Adjust throttle cable Inspect valve body Inspect valve body Disassemble and inspect transmission | AT-5 AT-5 AT-83 AT-45 |

TROUBLESHOOTING (Cont'd)

| Problem | Possible cause | Remedy | Page |
|--|---|--|--|
| Drag, binding or tie-up on 1-2, 2-3 or 3-OD up-shift | Manual linkage out of adjustment Valve body faulty Transmission faulty | Adjust linkage Inspect valve body Disassemble and inspect transmission | AT-5 AT-83 AT-45 |
| No Lock-up in 2nd, 3rd or OD | Electric control faulty Valve body faulty Solenoid valve faulty Transmission faulty | Inspect electric control Inspect valve body Inspect valve body Disassemble and inspect transmission | AT-6 AT-83 AT-83 AT-45 |
| Harsh down-shift | Throttle cable out of adjustment Throttle cable and cam faulty Accumulator pistons faulty Valve body faulty Transmission faulty | Adjust throttle cable Inspect throttle cable and cam Inspect accumulator pistons Inspect valve body Disassemble and inspect transmission | AT-5 AT-37 AT-112 AT-83 AT-45 |
| No down-shift when coasting | Valve body faulty Solenoid valve faulty Electric control faulty | Inspect valve body Inspect solenoid valve Inspect electric control | AT-83 AT-19 AT-6 |
| Down-shift occurs too quickly or late while coasting | Throttle cable faulty Valve body faulty Transmission faulty Solenoid valve faulty Electric control faulty | Inspect throttle cable Inspect valve body Disassemble and inspect transmission Inspect solenoid valve Inspect electric control | AT-37 AT-83 AT-45 AT-19 AT-6 |
| No. OD-3, 3-2 or 2-1 kickdown | Solenoid valve faulty Electric control faulty Valve body faulty | Inspect solenoid valve Inspect electric control Inspect valve body | AT-19 AT-6 AT-83 |
| No engine braking in "2" or "L" range | Solenoid valve faulty Electric control faulty Valve body faulty Transmission faulty | Inspect solenoid valve Inspect electric control Inspect valve body Disassemble and inspect transmission | AT-19 AT-6 AT-83 AT-45 |
| Vehicle does not hold in "P" | Manual linkage out of adjustment Parking lock pawl cam and spring faulty | Adjust linkage Inspect cam and spring | AT-5 AT-37 |

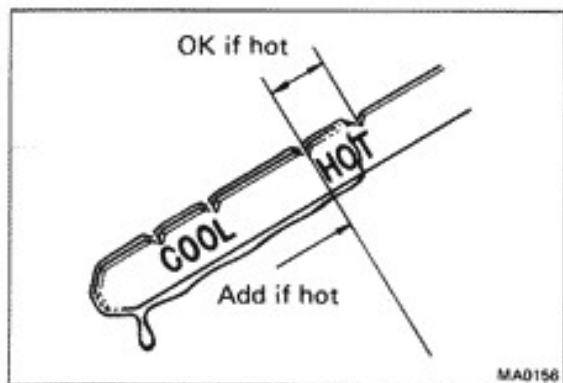

ATF INSPECTION

1. CHECK FLUID LEVEL (See page MA-13)
2. CHECK FLUID CONDITION
If the ATF smells burnt or is black, replace it.
3. REPLACE ATF (See page MA-10)

ADJUSTMENTS

ADJUSTMENT OF THROTTLE CABLE

1. DEPRESS ACCELERATOR PEDAL ALL THE WAY AND CHECK THAT THROTTLE VALVE OPENS FULLY
If the throttle valve does not open fully, adjust the accelerator link.
2. FULLY DEPRESS ACCELERATOR
3. LOOSEN ADJUSTMENT NUTS
4. ADJUST THROTTLE CABLE
 - (a) Adjust the cable housing so that the distance between the end of the boot and the stopper on the cable is correct.
Distance: 0 – 1 mm (0 – 0.04 in.)
 - (b) Tighten the adjusting nuts.
 - (c) Recheck the adjustments.

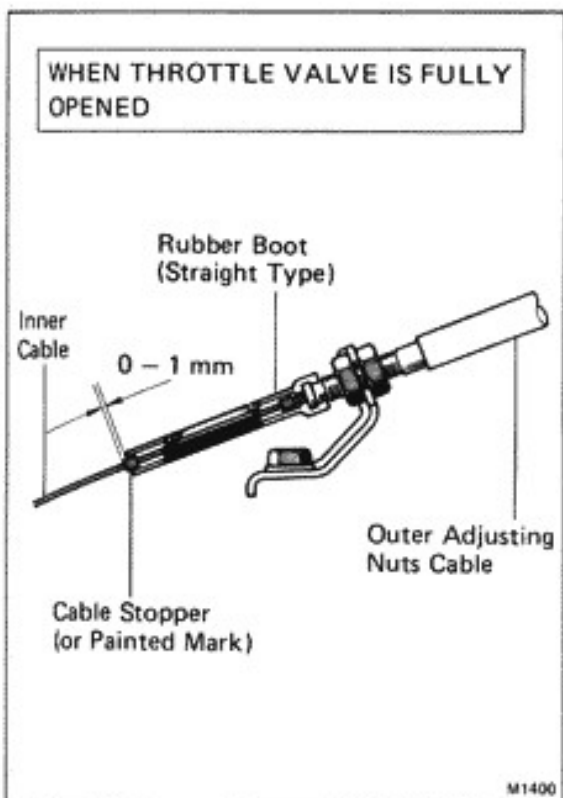

ADJUSTMENT OF FLOOR SHIFT LINKAGE

ADJUST SHIFT LINKAGE

- (a) Loosen the nut on the shift linkage.
- (b) Push the manual lever fully rearward.
- (c) Return the lever two notches to the NEUTRAL position.
- (d) Set the shift selector in "N".
- (e) While holding the selector lightly toward the "R" range side, tighten the shift linkage nut.

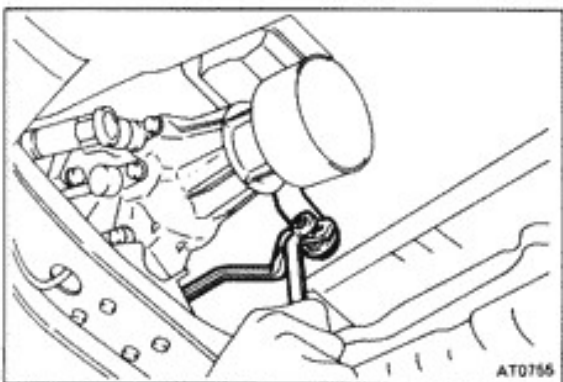

ADJUSTMENT OF NEUTRAL START SWITCH

If the engine will start with the shift selector in any range other than "N" or "P", adjustment is required.

1. LOOSEN NEUTRAL START SWITCH BOLT AND SET SHIFT SELECTOR IN "N" RANGE
2. ADJUST NEUTRAL START SWITCH
 - (a) Disconnect the neutral start switch connector.
 - (b) Connect the ohmmeter between the terminals.
 - (c) Adjust the switch to the point where there is continuity between N and B terminals.
 - (d) Connect the neutral start switch connector.
3. TORQUE NEUTRAL START SWITCH BOLT
Torque: 55 kg-cm (48 in.-lb, 5.4 N·m)

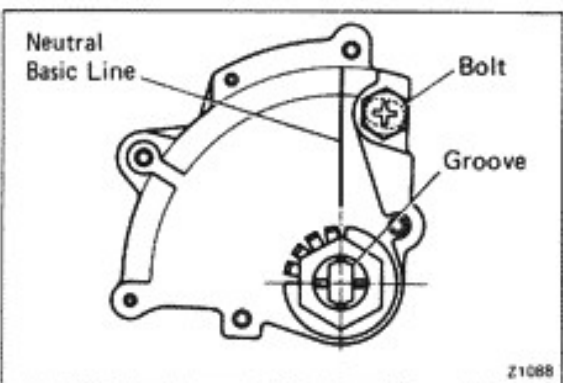

ELECTRIC CONTROL CIRCUIT

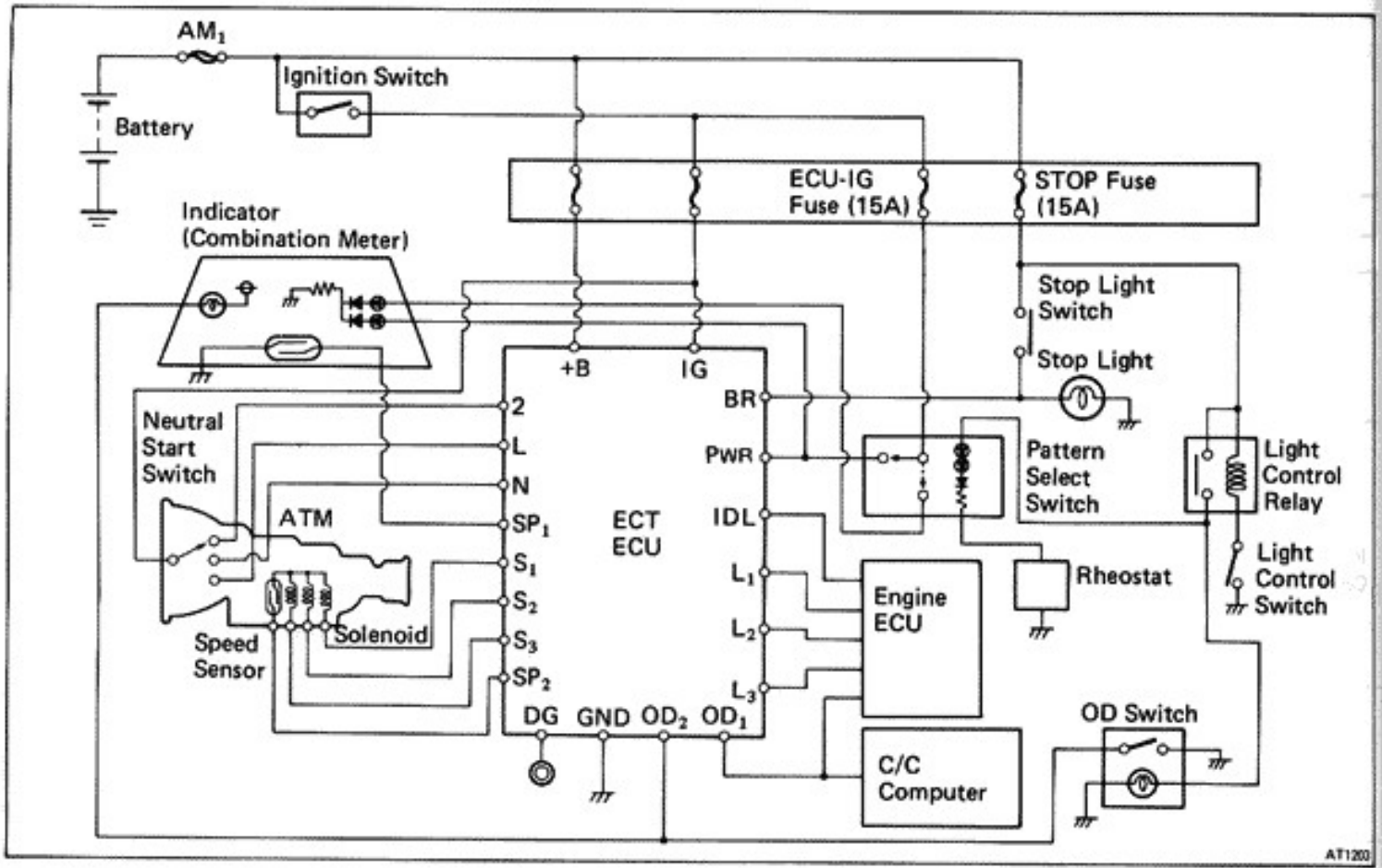

AT1203

COMPONENTS

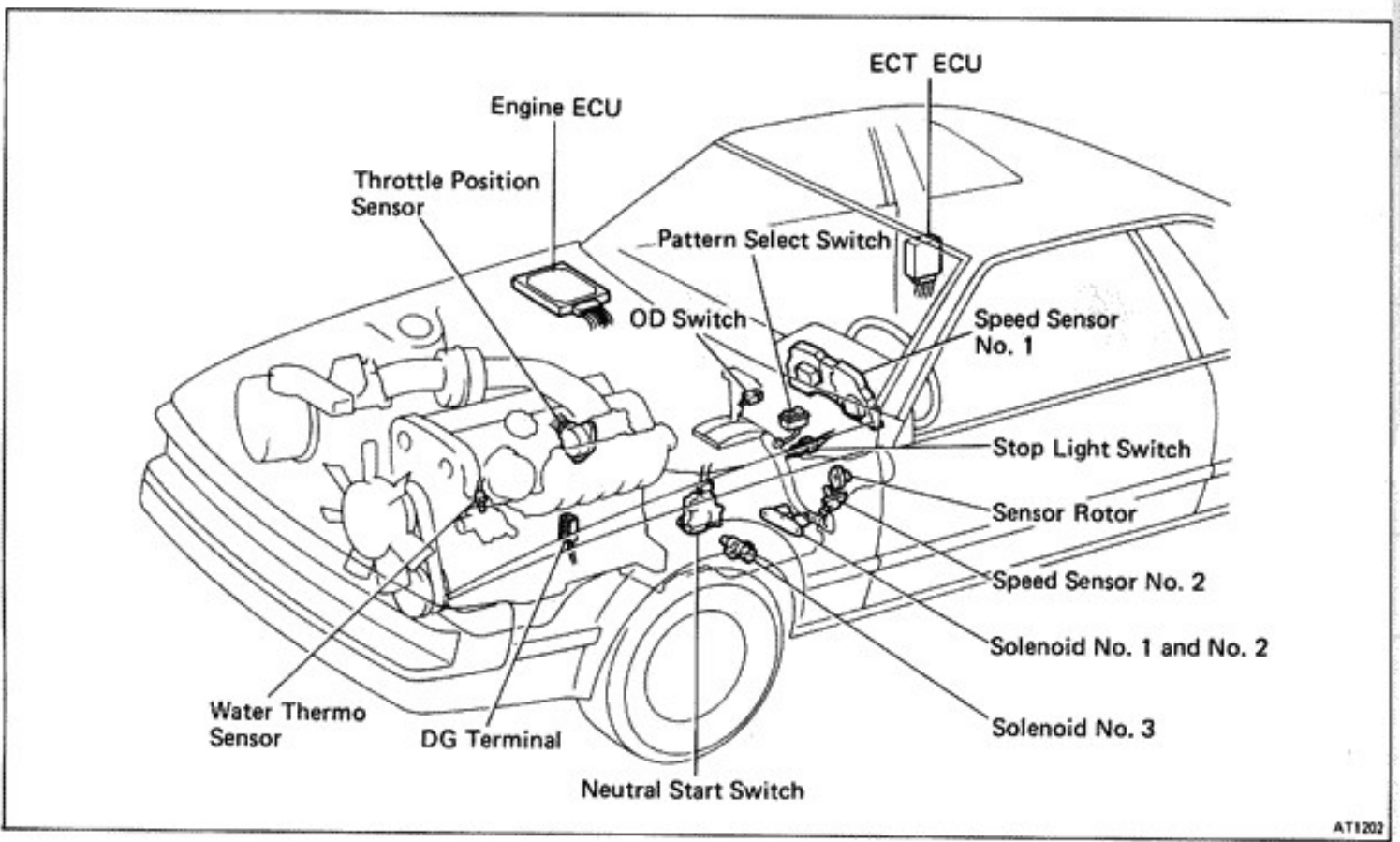

AT1203

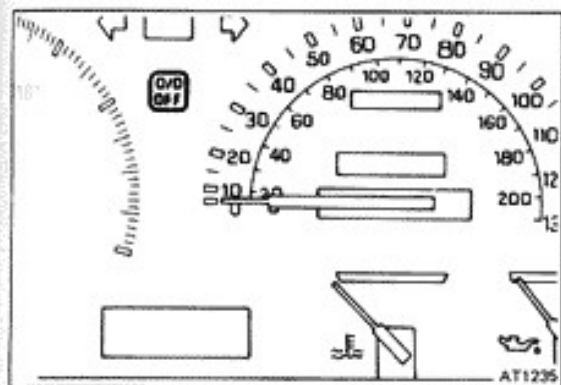

TROUBLESHOOTING OF ELECTRICAL CONTROL CIRCUIT

Description

1. A self-diagnosis function is built into the electrical control system. Warning is indicated by the overdrive OFF indicator light.

NOTE: Warning and diagnostic codes can be read only when the overdrive switch is ON. If OFF, the overdrive light is lit continuously and will not blink.

- (a) If a malfunction occurs within the speed sensors (No. 1 or 2) or solenoids (No. 1 or 2), the overdrive OFF light will blink to warn the driver.

However, there will be no warning of a malfunction with solenoid No. 3.

- (b) The diagnostic code can be read by the number of blinks of the overdrive indicator light when DG terminal and body ground are short-circuited. (See page AT-8)
- (c) The throttle position sensor or brake signal are not indicated, but inspection can be made by checking the voltage at DG terminal.
- (d) The signals to each gear can be checked by measuring the voltage at DG terminal.

2. The diagnostic code (trouble code) is retained in memory by the CPU (of ECT ECU) and due to back-up voltage, is not canceled out when the engine is turned off. Consequently, after repair, it is necessary to turn the ignition switch off and remove the fuse STOP (15A) or disconnect the ECT ECU connector to cancel out the diagnostic (trouble) code. (See page AT-10)

NOTE:

- Low battery voltage will cause faulty operation of the diagnosis system. Therefore, always check the battery first.
- Use a voltmeter and ohmmeter that have an impedance of at least 10 K Ω /V.

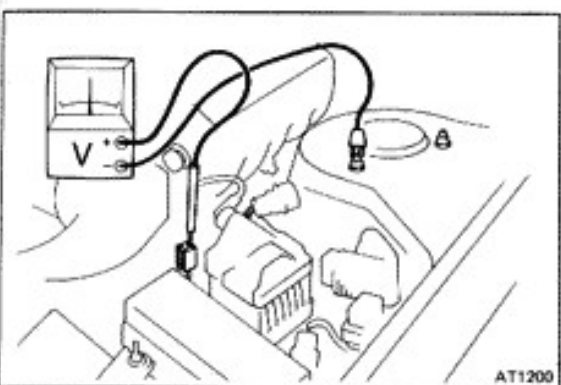
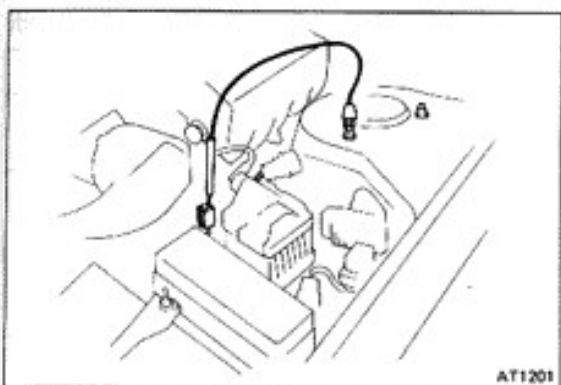

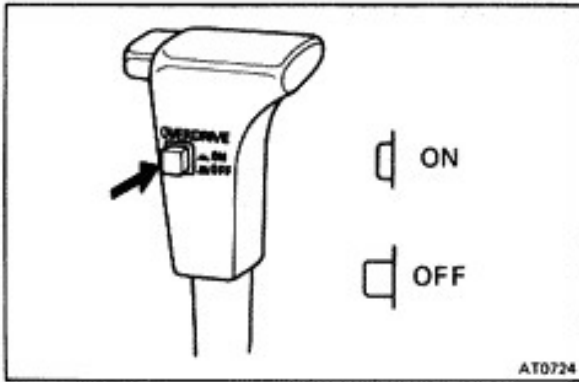

AT0724

OUTPUT OF DIAGNOSTIC CODE

1. Turn the ignition switch and OD switch ON. Do not start the engine.
2. Using a service wire, short the DG terminal and body ground.
3. Read the diagnostic code as indicated by the number of flashes of the "OD OFF light".

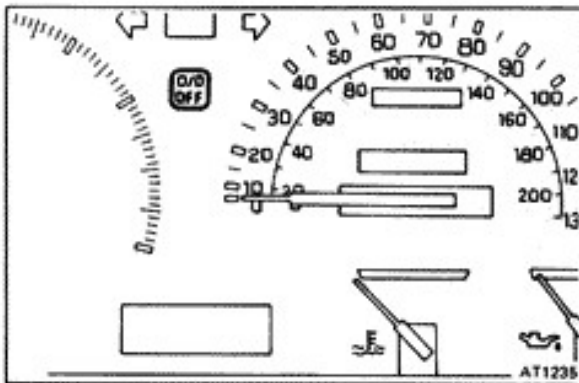
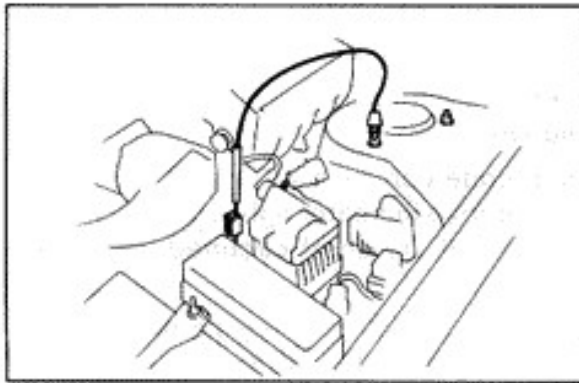

AT1235

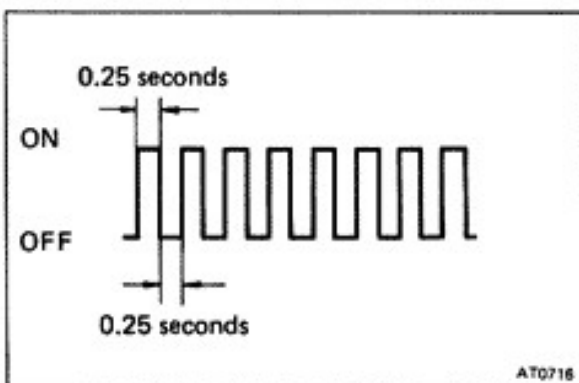

AT0716

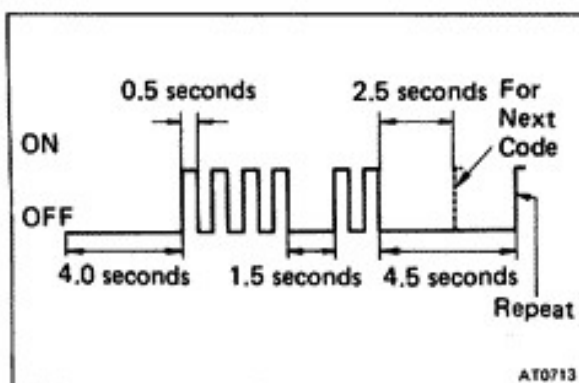

AT0713



Diagnostic Codes Indication

- (a) If the system is operating normally (no malfunction), the light will blink once every 0.25 seconds.
- (b) In event of a malfunction, the light will blink once every 0.5 seconds. The first number of blinks will equal the first digit of a two digit diagnostic code. After a 1.5 seconds pause, the 2nd number of blinks will equal the 2nd number of a two digit diagnostic code. If there are two or more codes, there will be a 2.5 seconds pause between each.

NOTE: In event of a number of trouble codes, indication will begin from the smaller value and continue in order to the larger.

4. After the diagnosis check, remove the service wire from the DG terminal.

Diagnostic Code

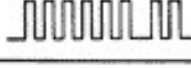
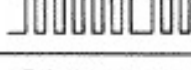
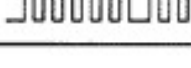
| Code No. | Light Pattern | Diagnosis System |
|----------|--|--|
| 42 |  | Defective No. 1 speed sensor (in combination meter) Severed wire harness or short circuit |
| 61 |  | Defective No. 2 speed sensor (in ATM) Severed wire harness or short circuit |
| 62 |  | Severed No. 1 solenoid or short circuit Severed wire harness or short circuit |
| 63 |  | Severed No. 2 solenoid or short circuit Severed wire harness or short circuit |
| 64 |  | Severed No. 3 solenoid or short circuit Severed wire harness or short circuit |

NOTE: If codes 62, 63 or 64 appear, there is an electrical malfunction with the solenoid.
Causes due to mechanical failure such as a stuck switch will not appear.

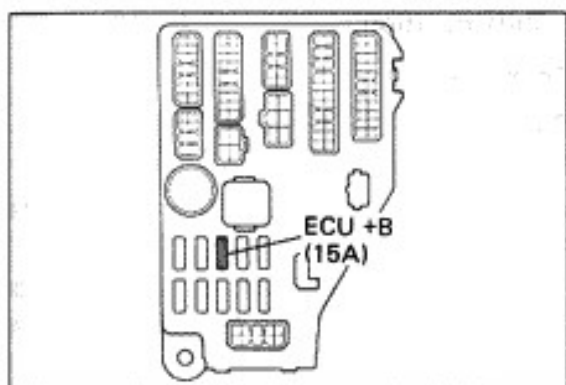

CANCEL OUT DIAGNOSTIC CODE

1. After repair of the trouble area, the diagnostic code retained in memory by the ECT ECU must be canceled out by removing the fuse ECU +B (15A) for 10 seconds or more depending on ambient temperature (the lower the temperature, the longer the fuse must be left out) with the ignition switch off.

NOTE:

- Cancellation can also be done by removing the battery negative (—) terminal, but in this case other memory systems (clock, radio ETR, etc.) will also be canceled out.
 - The diagnostic code can also be canceled out by disconnecting the ECT ECU connector.
 - If the diagnostic code is not canceled out, it will be retained by the ECT ECU and appear along with a new code in event of future trouble.
2. After cancellation, perform a road test, if necessary, to confirm that a "normal code" is now read on the OD OFF light.

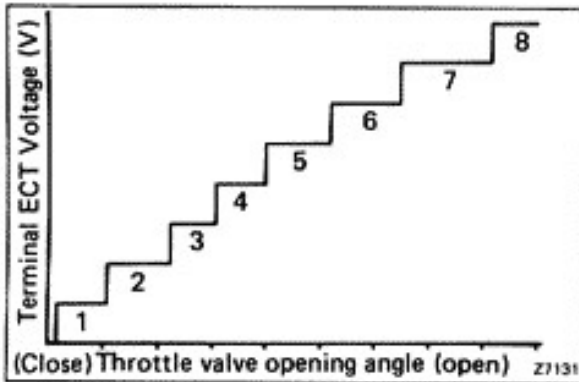
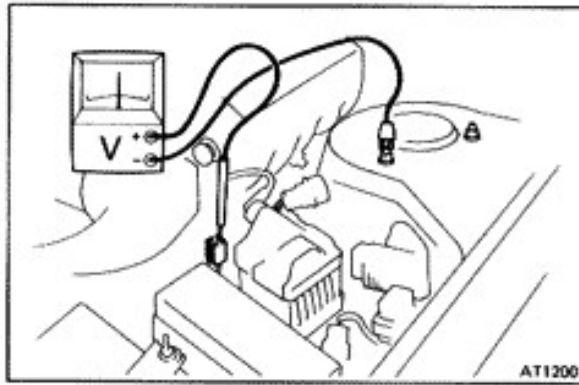

INSPECT TERMINAL ECT VOLTAGE

1. Inspect the throttle position sensor system.
 - (a) Turn the ignition switch to ON. Do not start the engine.
 - (b) Connect a voltmeter to the DG terminal and body ground.
 - (c) While slowly depressing the accelerator pedal, check that DG terminal voltage rises in sequence.

If the voltage is in proportion to the throttle opening angle and does not change, there is a malfunction with the throttle position sensor or circuit.

2. Inspect brake signal.
 - (a) Depress the accelerator pedal to where DG terminal indicates 8V.
 - (b) Depress the brake pedal and check the voltage reading for DG terminal.

Brake pedal depressed ... 0V
Brake pedal released 8V

If not as indicated, there is a malfunction with either the stop light switch or circuit.

3. Inspect each up shift position.
 - (a) Warm up the engine.
Coolant temperature: 80°C (176°F)
 - (b) Turn the OD switch ON.
 - (c) Place the pattern select switch in "Normal" and the shift selector in "D" range.
 - (d) During a road test (above 10 km/h or 6 mph) check that voltage at the DG terminal is as indicated below for each up-shift position.

| Terminal ECT (V) | Gear position |
|------------------|---------------|
| 0 | 1st |
| 2 | 2nd |
| 3 | 2nd Lock-up |
| 4 | 3rd |
| 5 | 3rd Lock-up |
| 6 | OD |
| 7 | OD Lock-up |

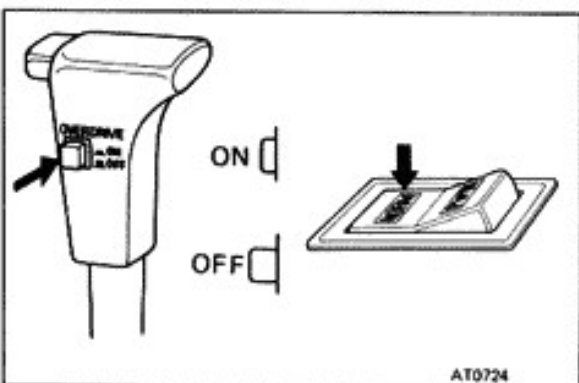

- (e) If voltage rises from 0V to 7V in the sequence shown, the control system is okay.
- (f) The voltage could rise anywhere between 0V — 8V before the vehicle reaches 10 km/h or 6 mph in first gear. The voltage jump depends on what percent the throttle valve is opened. This is a normal reading. Above 10 km/h or 6 mph, the voltmeter indicates the current gear.

NOTE: Determine the gear position by a light shock or change in engine rpm when shifting.

TROUBLESHOOTING

NOTE:

- If diagnostic code No. 42, 61, 62 or 63 occur, the overdrive indicator light will begin to blink immediately to warn the driver. However, an impact or shock may cause the blinking to stop although the code will still be retained in the ECT ECU memory until canceled out.
- There is no warning for diagnostic code No. 64.
- In event of a simultaneous malfunction of both speed sensors No. 1 and No. 2, no diagnostic code will appear and fail-safe will not function. However, when driving in "D" range, the transmission will not up-shift from first gear regardless of the vehicle speed.

Trouble No. 1 Blinking overdrive indicator light (while driving)

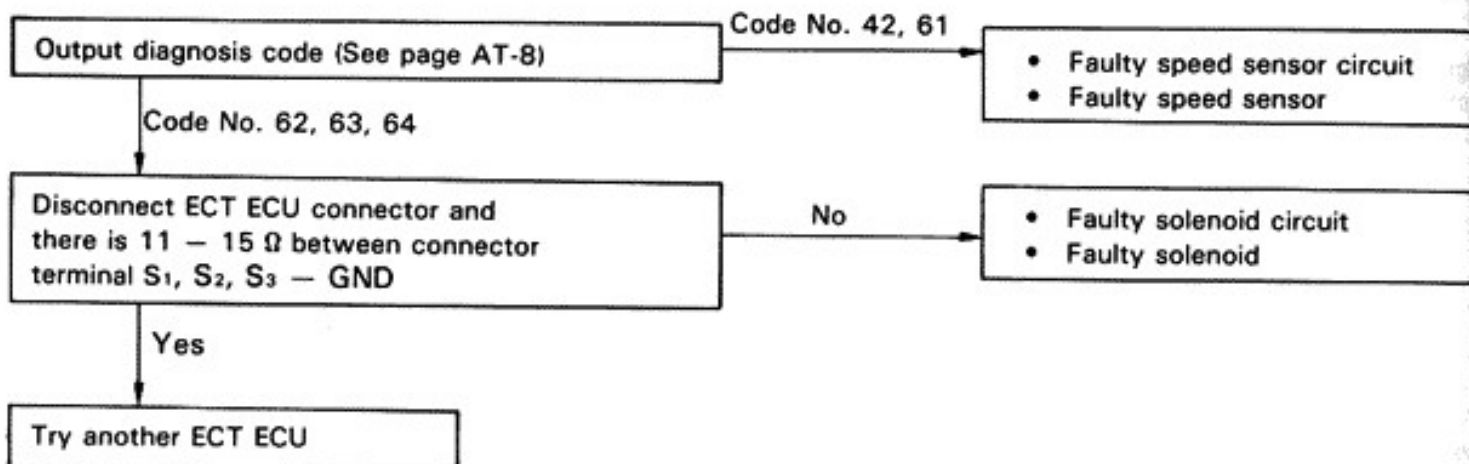

Trouble No. 2 No shifting

Warm up engine
Coolant temp: 80°C (176°F)
ATF temp: 50 — 80°C (122 — 176°F)

Output diagnostic code
(See page AT-8)

Diagnosis code

Proceed to trouble No. 1 (AT-12)

No indicate

Connect a voltmeter to the DG terminal and body.
Does DG terminal voltage vary with changes in throttle opening?

Yes

No

Is voltage between ECT ECU terminals BR and GND as follows?
0V: Brake pedal released
12V: Brake pedal depressed

No

Brake signal faulty

Yes

- Computer power source and earth faulty
- Throttle position signal faulty
- DG terminal wire open or short

Disconnect ECT ECU connector and road test.
Does the transmission operate in the respective gear when in the following ranges while driving?
D range Overdrive
2 range 3rd gear
L range 1st gear

No

Transmission faulty

Yes

Continued on page AT-14

Continued from page AT-13

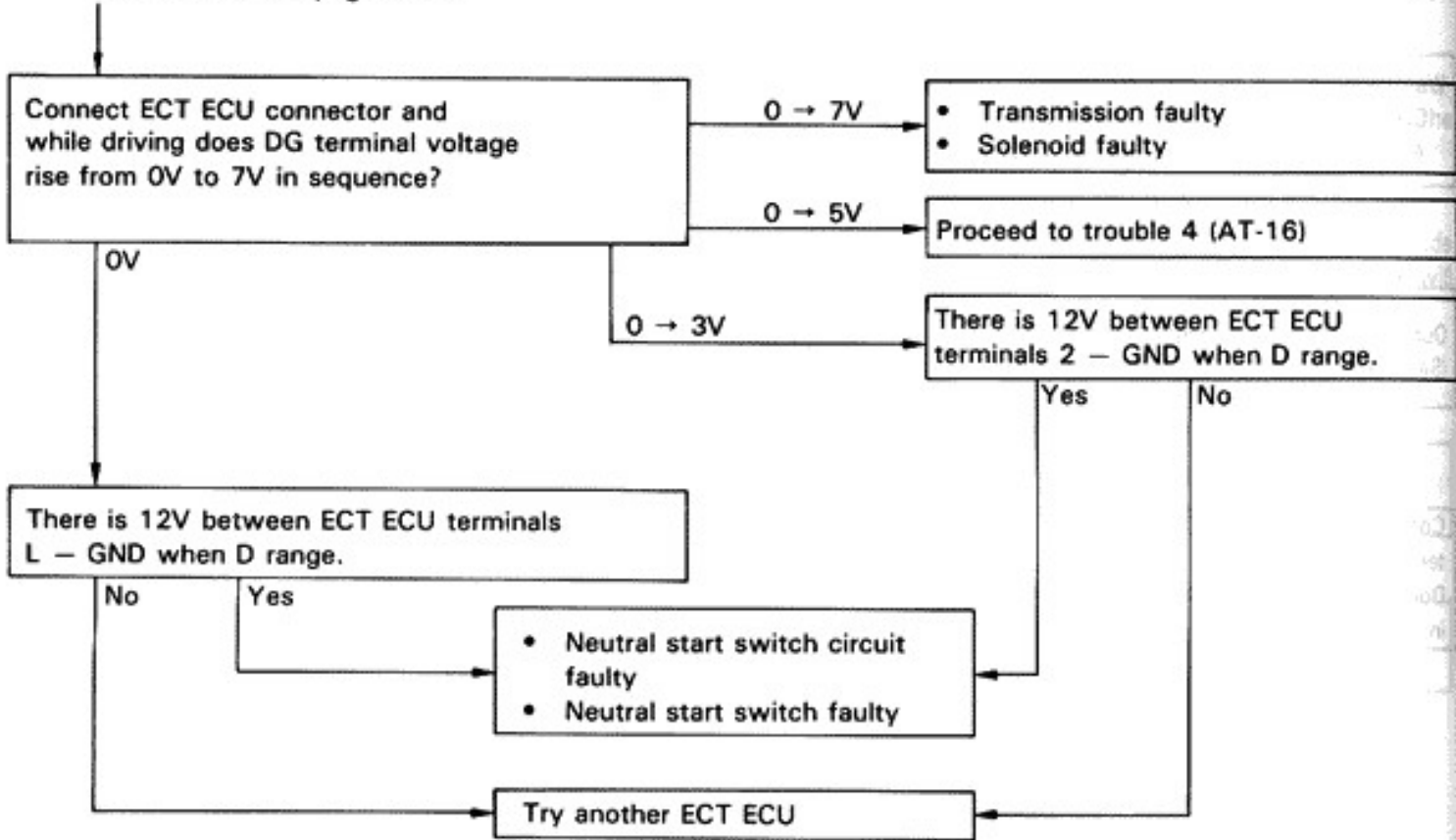

Trouble No. 3 Shift point too high or too low

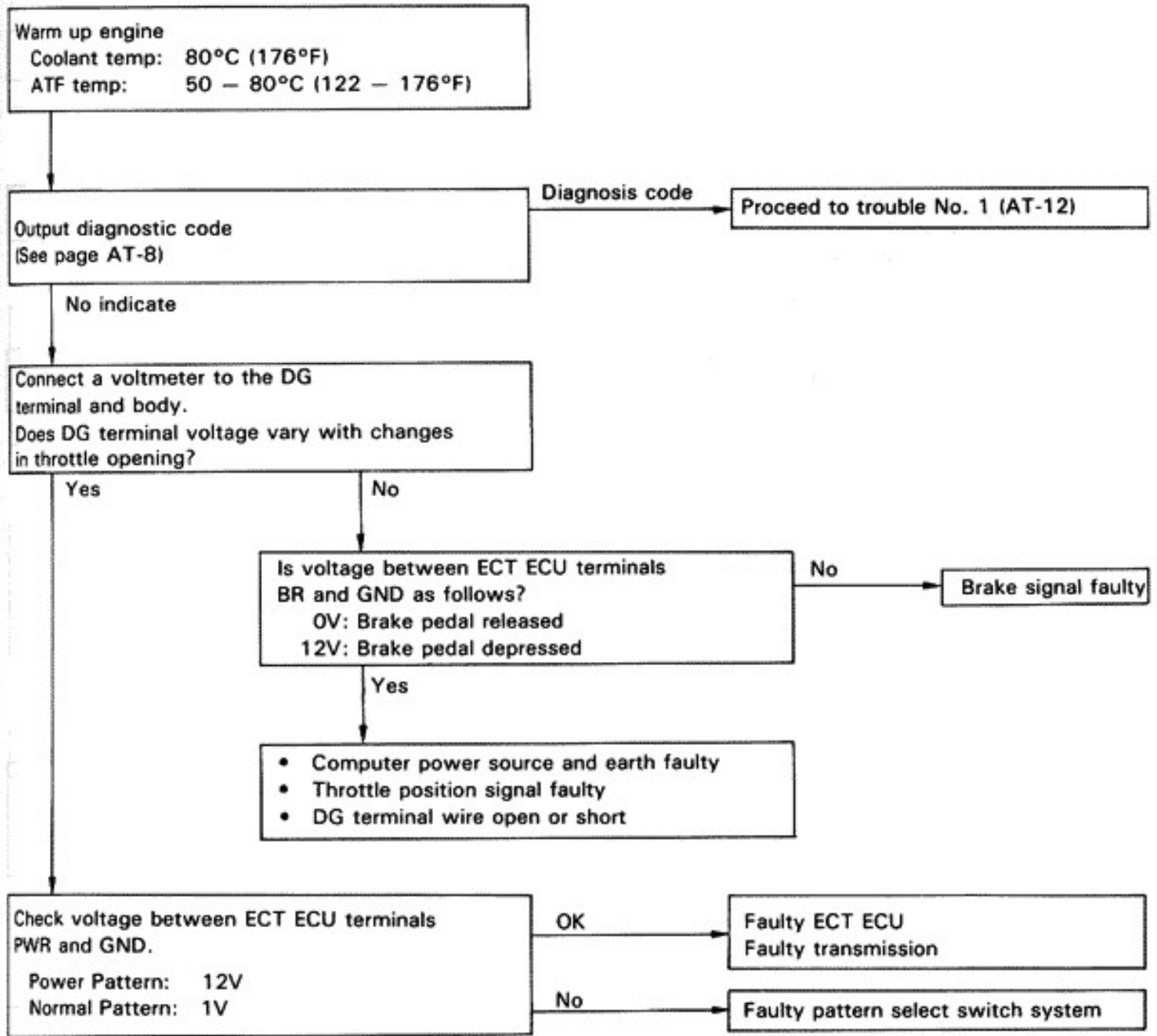

Trouble No. 4 No up-shift to overdrive (After warm-up)

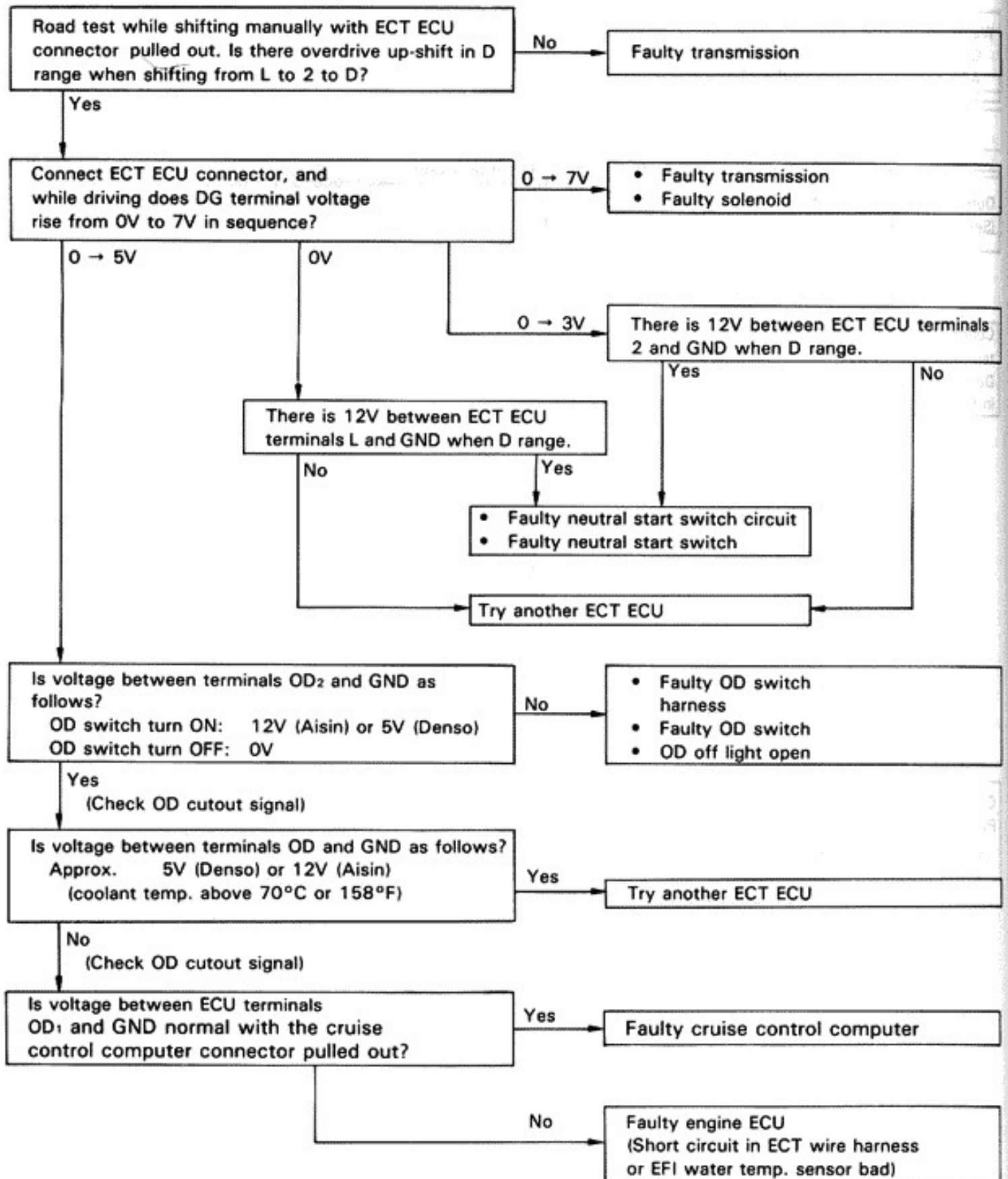

Trouble No. 5 No lock-up (After warm-up)

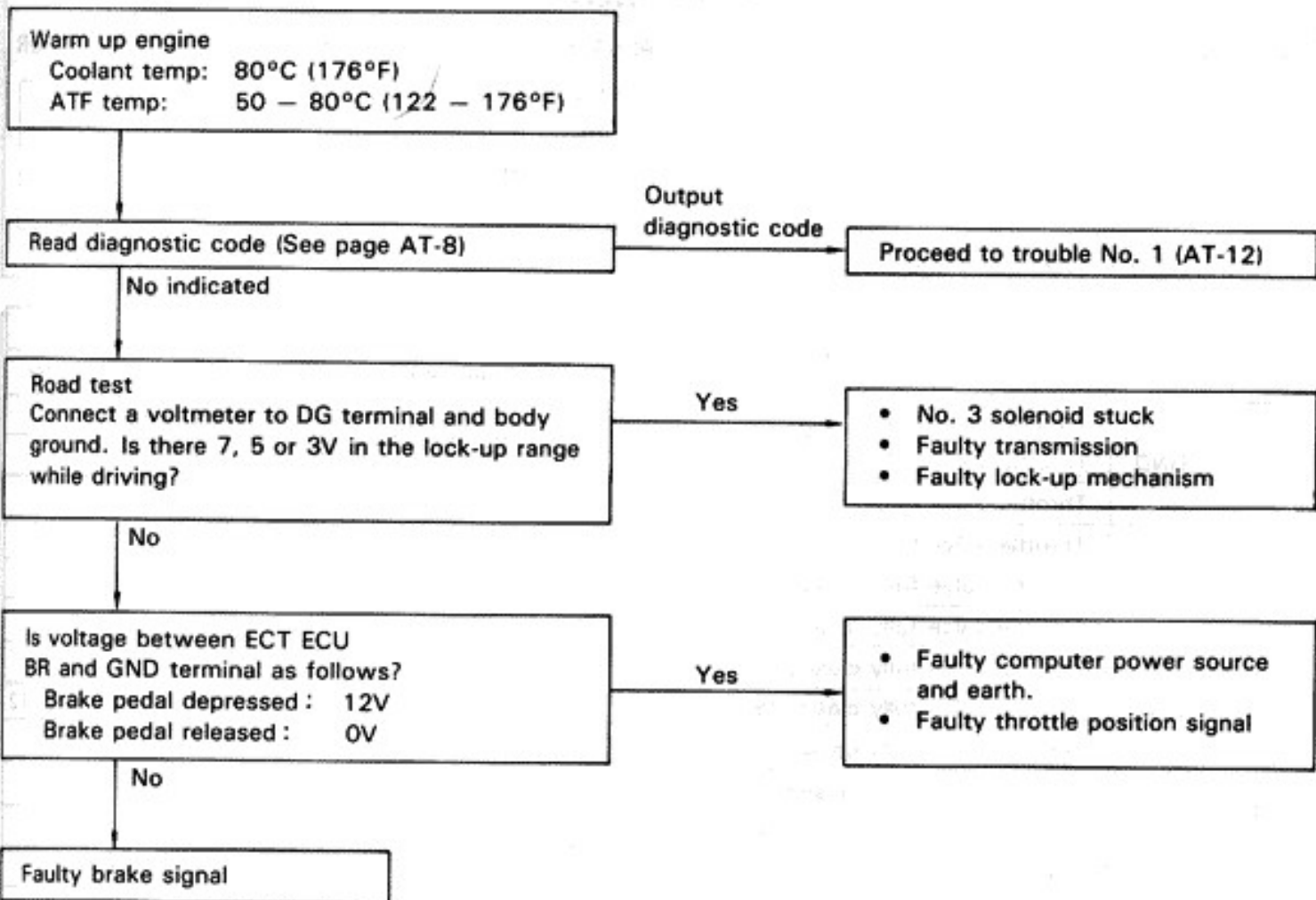

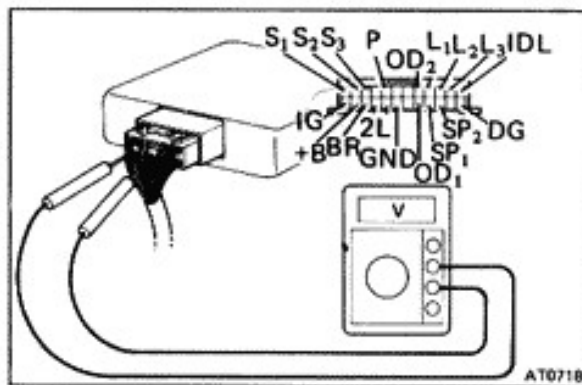

INSPECTION OF ELECTRIC CONTROL COMPONENTS

1. INSPECT VOLTAGE OF ECT COMPUTER CONNECTOR

- Remove the glove box.
- Turn on the ignition switch.
- Measure the voltage at each terminal.

| Terminal | Measuring condition | Voltage (V) | |
|---------------------------------------|---|-----------------------|--------------------------|
| | | DENSO type computer | AISIN type computer |
| L ₁ — GND | Throttle valve fully closed | 5 | 12 |
| | Throttle valve fully closed to fully open | 5 to 0 | 12 to 0 |
| | Throttle valve fully open | 0 | ← |
| L ₂ — GND | Throttle valve fully closed | 5 | 12 |
| | Throttle valve fully closed to fully open | 5 to 0 to 5 | 12 to 0 to 12 |
| | Throttle valve fully open | 5 | 12 |
| L ₃ — GND | Throttle valve fully closed | 5 | 12 |
| | Throttle valve fully closed to fully open | 5 to 0 to 5 to 0 to 5 | 12 to 0 to 12 to 0 to 12 |
| | Throttle valve fully open | 5 | 12 |
| IDL — GND | Throttle valve fully closed | 0 | ← |
| | Throttle valve opening above 1.5° | 12 | ← |
| SP ₁ — GND | Standing still | 5 or 0 | 12 or 0 |
| | Engine running, vehicle moving | 2.5 | 6 |
| BR — GND | When brake pedal is depressed | 12 | ← |
| | When brake pedal is not depressed | 0 | ← |
| 2 — GND | 2 range | 9 to 16 | ← |
| | Except 2 range | 0 to 2 | ← |
| L — GND | L range | 9 to 16 | ← |
| | Except L range | 0 to 2 | ← |
| S ₁ — GND | — | 12 | ← |
| S ₂ , S ₃ — GND | — | 0 | ← |
| OD ₁ — GND | Coolant temp. below 65°C (149°F) | 0 | ← |
| | Coolant temp. above 75°C (167°F) | 5 | 12 |
| OD ₂ — GND | OD main switch turn ON | 5 | 12 |
| | OD main switch turn OFF | 0 | ← |
| IG — GND | Standing still | 12 | ← |
| SP ₂ — GND | Standing still | 5 or 0 | ← |
| | Engine running | 4 | ← |
| PWR — GND | PWR pattern | 12 | ← |
| | Except PWR pattern | 0 to 2 | ← |
| +B — GND | — | 12 | ← |

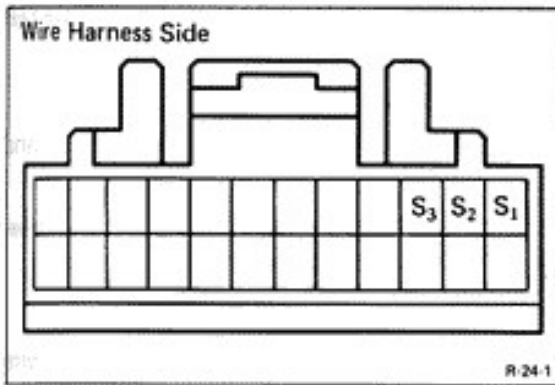

2. INSPECT SOLENOID

- (a) Disconnect the connector from the ECT ECU.
- (b) Measure the resistance between S₁, S₂, S₃ and ground.

STD: 11 – 15Ω

- (c) Apply battery voltage to the solenoid. At this time, check that an operation noise can be heard from the solenoid.

NOTE: If there is foreign matter in the solenoid valve, there will be no fluid control even with solenoid operation.

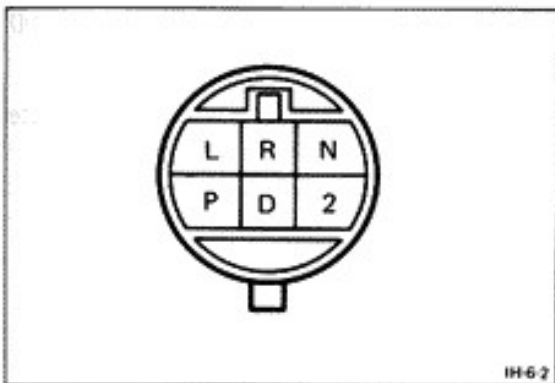

3. INSPECT NEUTRAL START SWITCH

- (a) Shift the lever into the L or 2 range.
- (b) Disconnect the connector near the starter motor.
- (c) Check that there is continuity between L, 2 and ground.

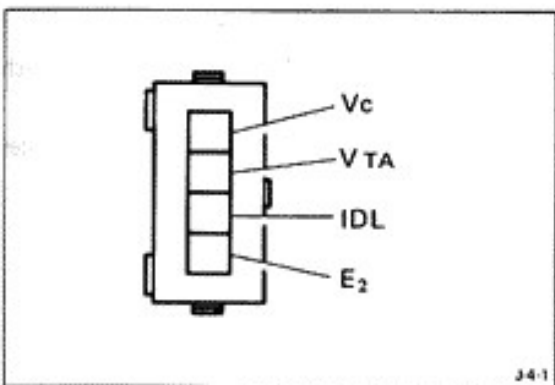

4. INSPECT THROTTLE POSITION SENSOR

Using an ohmmeter, check the resistance between each terminal.

| Terminal | Throttle valve condition | Resistance (kΩ) |
|----------------------------------|--------------------------|-----------------|
| IDL – E ₂ | Fully closed | 0 |
| | Open | Infinity |
| V _c – E ₂ | — | 3 – 7 |
| V _{TA} – E ₂ | Fully closed | 0.2 – 0.8 |
| | Fully open | 3.3 – 10 |

5. INSPECT BRAKE SIGNAL

Check that the brake light comes on when the brake pedal is depressed.

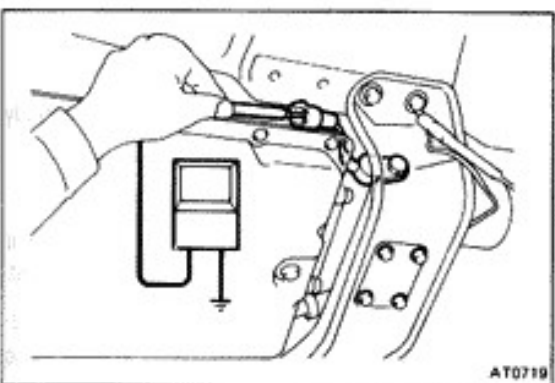

6. INSPECT SPEED SENSOR NO.2

- (a) Jack up the rear wheel on one side.
- (b) Connect an ohmmeter between the connector and ground.
- (c) Spin the wheel and check that the meter needle deflects from 0Ω to ∞Ω.

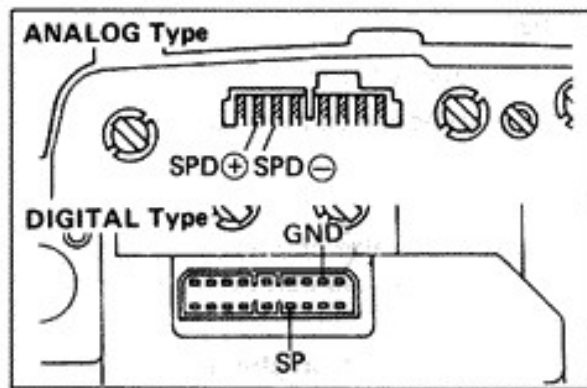

7. INSPECT SPEED SENSOR NO.1 IN COMBINATION METER

[Analog Type]

- Remove the combination meter.
- Connect an ohmmeter between terminals SPD \oplus and SPD \ominus .
- Revolve the meter shaft and check that the meter needle repeatedly deflects from 0Ω to $\infty\Omega$.

[Digital Type]

- Remove the combination meter with connected wire harness.
- Connect a voltmeter between terminals SP and GND.
- Turn the ignition switch ON.
- Revolve the meter shaft and check that the voltmeter needle repeatedly deflects from 0V to 2V.

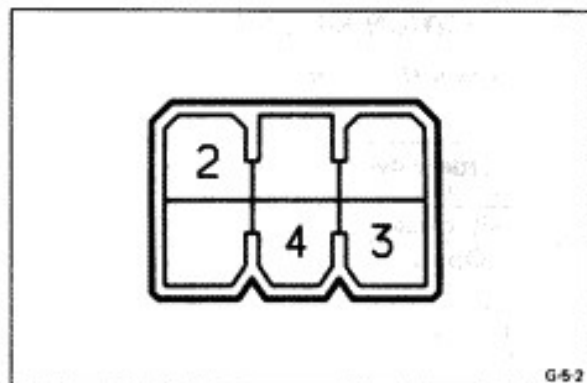

8. INSPECT PATTERN SELECTION SWITCH

Inspect that there is continuity between 2 and each terminal.

NOTE: As there are diodes inside, be careful of the tester probe polarity.

| Terminal \ Pattern | 2 | 4 | 3 |
|--------------------|---|---|---|
| NORM | | | |
| PWR | | | |

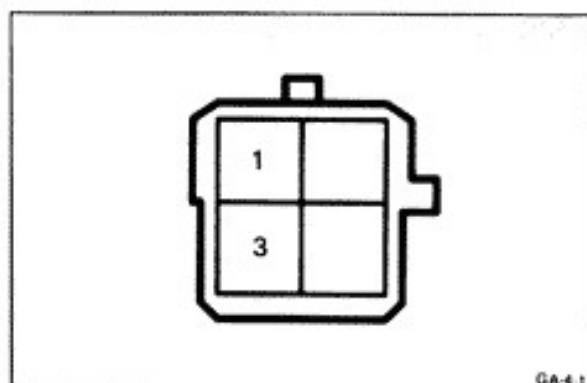

9. INSPECT OD SWITCH

Inspect that there is continuity between 1 and 3.

| S/W position \ Terminal | 1 | 3 |
|-------------------------|---|---|
| ON | | |
| OFF | | |

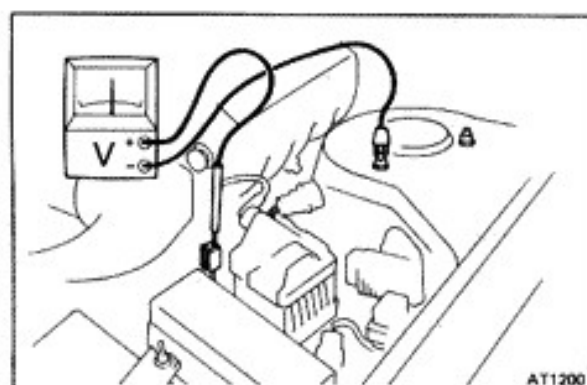

10. INSPECT LOCK-UP MECHANISM

- Warm up the coolant and ATF.
- Connect a voltmeter to the DG terminal and body ground.
- Select the normal pattern.
- Drive at around 50 km/h (31 mph) to where 7.5 or 3V appears on the voltmeter (this is the lock-up range).
- Depress the accelerator pedal and read the tachometer. If there is a big jump in engine rpm there is no lock-up.

INSPECTION OF MANUAL SHIFTING

NOTE: With this inspection, it can be determined whether the trouble lies within the electrical circuit or a mechanical trouble in the transmission.

1. DISCONNECT ECT ECU CONNECTOR

- (a) Remove the glove box.
- (b) Disconnect the ECT ECU connector.

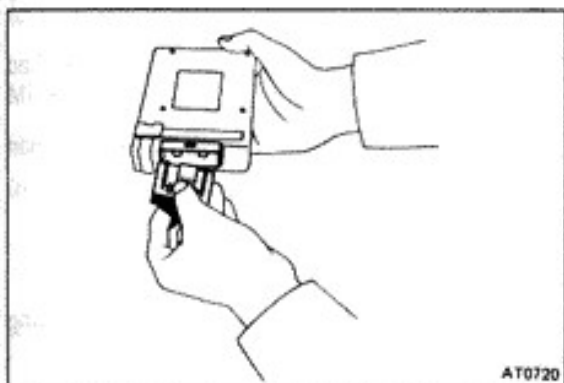

2. INSPECT MANUAL DRIVING OPERATION

- (a) While driving, check that there is respective gear change in each drive range.

| | | | | | |
|----------------|---------|---------|---------|---------|-----------|
| Shift position | D range | 2 range | L range | R range | P range |
| Gear position | OD | 3rd | 1st | Reverse | Pawl Lock |

- (b) Vehicle moves in reverse in "R" range.
- (c) Vehicle does not move in "N" range.
- (d) Parking pawl locks in "P" range.

If not as specified, check the transmission.

NOTE: If a problem is indicated with the ECT even if this check is as specified, the trouble lies within the electrical circuit.

STALL TEST

The object of this test is to check the overall performance of the transmission and engine by measuring the maximum engine speeds at the "D" and "R" ranges.

CAUTION:

- Perform the test at normal operation fluid temperature (50 – 80°C or 122 – 176°F).
- Do not continuously run this test longer than 5 seconds.

MEASURE STALL SPEED

- Chock the four wheels.
- Mount an engine tachometer.
- Fully apply the parking brake.
- Step down strongly on the brake pedal with your left foot.
- Start the engine.
- Shift into "D" range. Step all the way down on the accelerator pedal with your right foot. Quickly read the highest engine rpm at this time.

Stall speed: 2,100 ± 150 rpm

- Perform the same test in "R" range.

EVALUATION

- If the engine speed is the same for both ranges but lower than specified value:
 - Engine output is insufficient.
 - Stator one-way clutch is not operating properly.

NOTE: If more than 600 rpm below the specified value, the torque converter could be at fault:

- If the stall speed in "D" range is higher than specified:
 - Line pressure too low
 - Front clutch slipping
 - One-way clutch No. 2 not operating properly
 - OD one-way clutch not operating properly
- If the stall speed in "R" range is higher than specified:
 - Line pressure too low
 - Rear clutch slipping
 - Brake No. 3 slipping
 - OD one-way clutch not operating properly
- If the stall speed in "R" and "D" range is higher than specified:
 - Line pressure too low
 - Improper fluid level
 - OD one-way clutch not operating properly

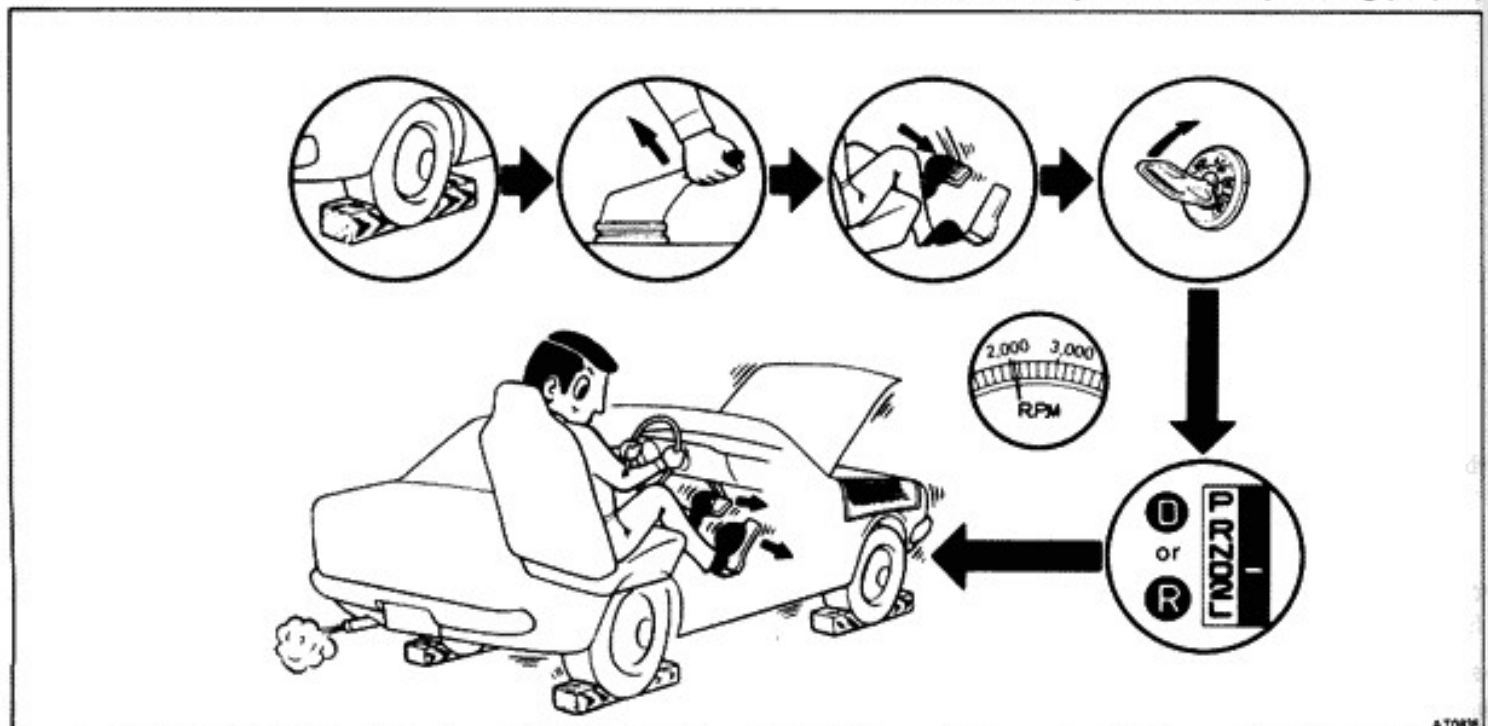

TIME LAG TEST

If the shift lever is shifted while the engine is idling, there will be a certain time elapse or lag before the shock can be felt. This is used for checking the condition of the OD clutch, front clutch, rear clutch and brake No. 3.

CAUTION:

- (a) Perform the test at normal operation fluid temperature (50 — 80°C or 122 — 176°F).
- (b) Be sure to allow a one minute interval between tests.
- (c) Make three measurements and take the average value.

MEASURE TIME LAG

- (a) Fully apply the parking brake.
- (b) Start the engine.
Check idling speed (A/C OFF)
 "N" range 650 rpm
- (c) Shift the shift lever from "N" to "D" range. Using a stop watch, measure the time it takes from shifting the lever until the shock is felt.

Time lag: Less than 1.2 seconds

- (d) In same manner, measure the time lag for "N" → "R".

Time lag: Less than 1.5 seconds

EVALUATION

- (a) If "N" → "D" time lag is longer than specified:
 - Line pressure too low
 - Front clutch worn
 - OD one-way clutch not operating properly
- (b) If "N" → "R" time lag is longer than specified:
 - Line pressure too low
 - Rear clutch worn
 - Brake No.3 worn
 - OD one-way clutch not operating properly

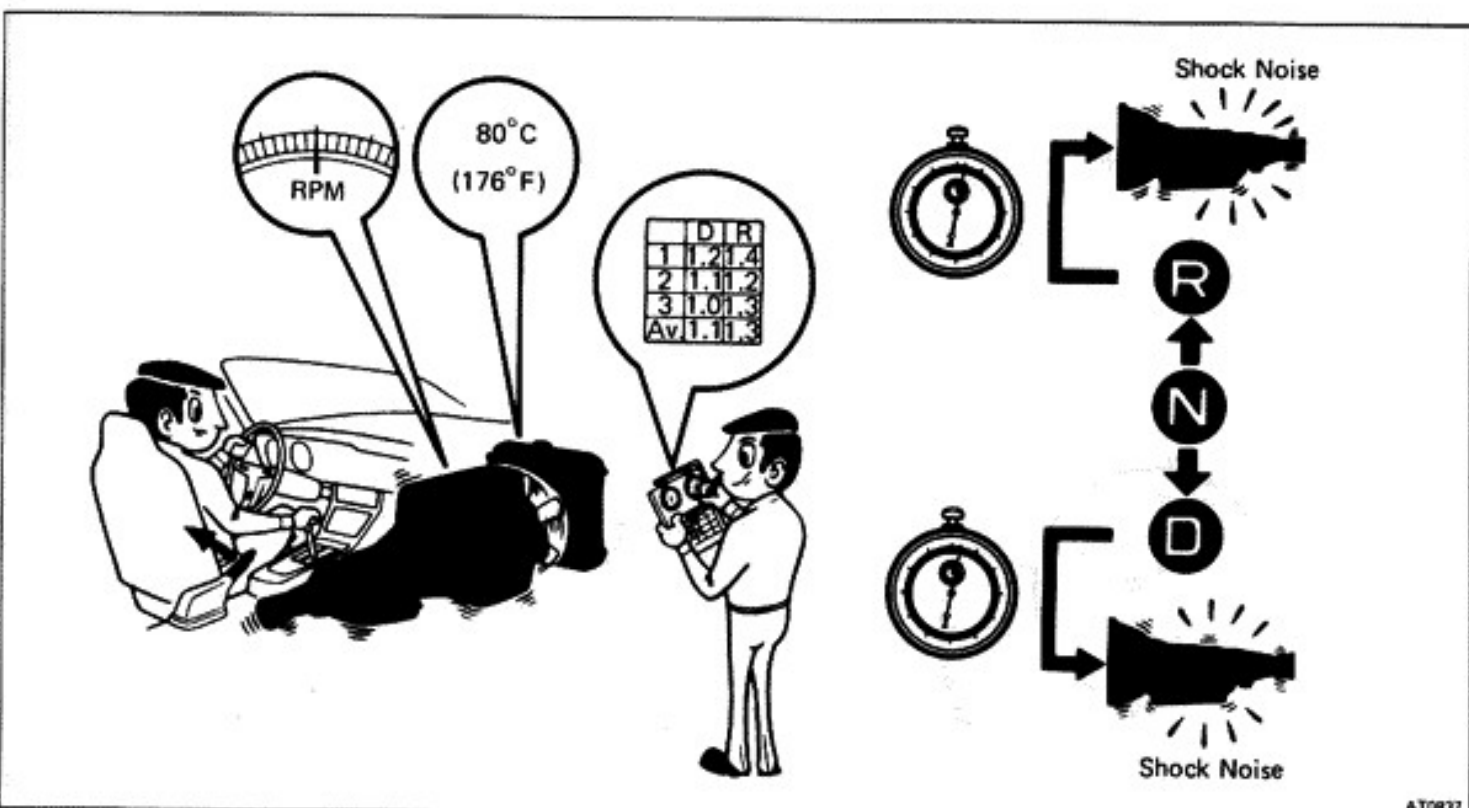

HYDRAULIC TEST

1. PREPARATION

- Warm up the transmission fluid.
- Remove the transmission case test plug and mount the hydraulic pressure gauge.

SST 09992-00093 Oil pressure gauge

CAUTION: Perform the test at normal operating fluid temperature (50 — 80°C or 122 — 176°F).

2. MEASURE LINE PRESSURE

- Fully apply the parking brake and chock four wheels.
- Start the engine and check idling rpm.
- Shift into "D" range, step down strongly on the brake pedal with your left foot and, while manipulating the accelerator pedal with the right foot, measure the line pressures at the engine speeds specified in table.
- In the same manner, perform the test in "R" range.

| Engine speed rpm | Line pressure | |
|---------------------|-----------------|-----------------|
| | "D" range | "R" range |
| Idling | 3.7 — 4.1 | 5.1 — 5.7 |
| | (53 — 58) | (73 — 81) |
| | (363 — 402) | (500 — 559) |
| Stall | 10.6 — 13.0 | 14.3 — 19.0 |
| | (151 — 185) | (203 — 270) |
| | (1,040 — 1,275) | (1,402 — 1,863) |

- If the measured pressures are not up to specified values, recheck the throttle cable adjustment and perform a retest.

EVALUATION

- If the measured values at all ranges are higher than specified:
 - Throttle cable out-of-adjustment
 - Throttle valve defective
 - Regulator valve defective
- If the measured values at all ranges are lower than specified:
 - Throttle cable out-of-adjustment
 - Throttle valve defective
 - Regulator valve defective
 - Oil pump defective
 - OD clutch defective
- If pressure is low in "D" range only:
 - "D" range circuit fluid leakage
 - Front clutch defective
- If pressure is low in "R" range only:
 - "R" range circuit fluid leakage
 - Rear clutch defective
 - Brake No.3 defective

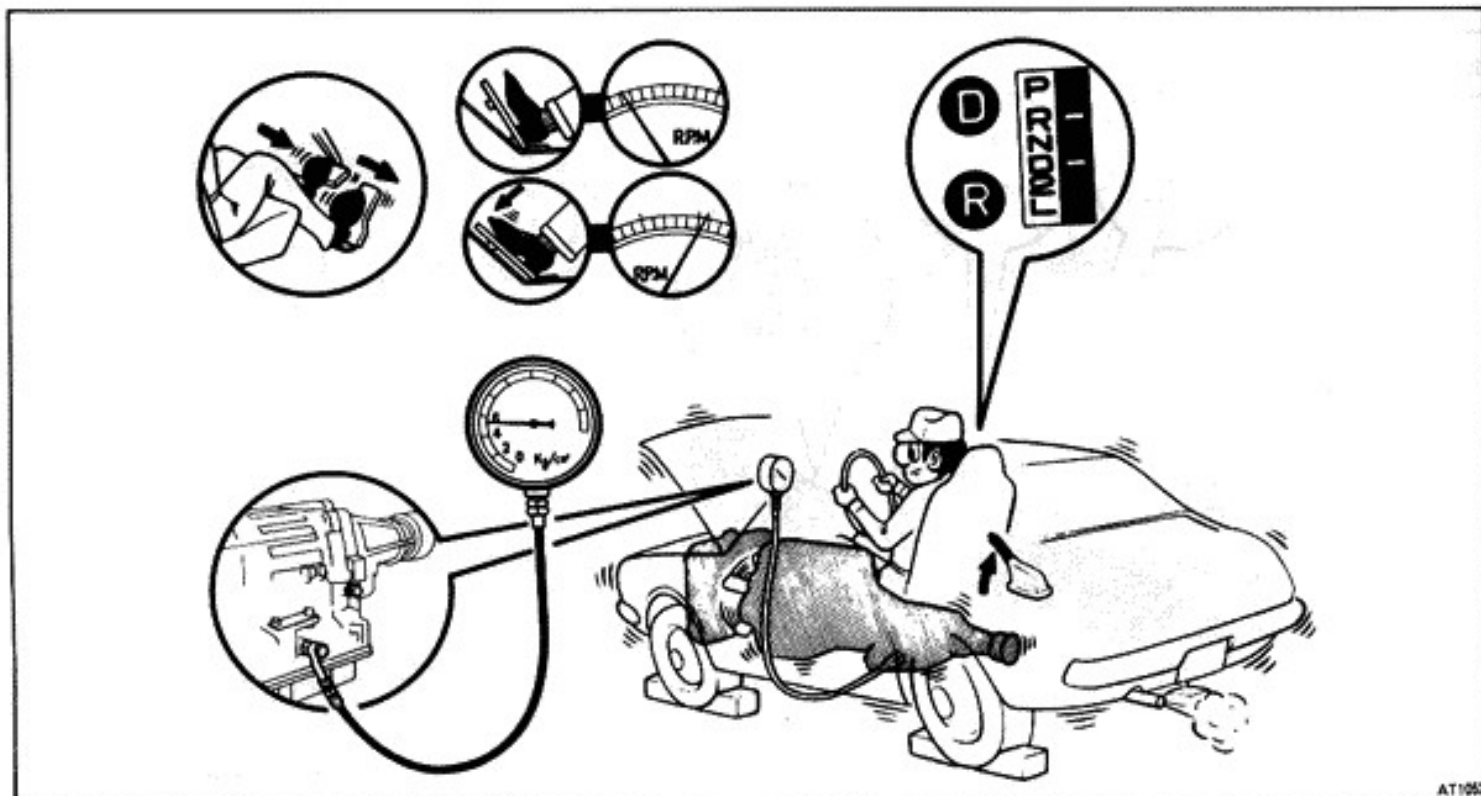

ROAD TEST

CAUTION: Perform the test at normal operating fluid temperature (50 – 80°C or 122 – 176°F).

1. "D" RANGE TEST IN NORM, AND PWR PATTERN RANGES

Shift into "D" range and hold the accelerator pedal constant at 50 % and 100 % throttle valve opening positions.

Push in one of the pattern selector buttons and check the following:

- (a) 1-2, 2-3, 3-OD and lock-up up-shifts should take place, and shift points should conform to those shown in the automatic shift diagram.

NOTE:

- (1) There is no 3rd up-shift or lock-up when coolant temperature is below 35°C (95°F) and speed is under 48 km/h (30 mph).
- (2) There is no OD up-shift or lock-up when coolant is below 63°C (145°F) and speed is under 63 km/h (39 mph), or if there is a 10 km/h (6 mph) difference between the set cruise control speed.

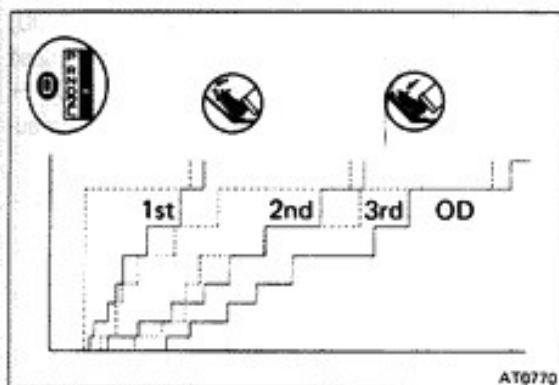

EVALUATION

- (1) If there is no 1 → 2 up-shift:
- No.2 solenoid is stuck
 - 1-2 shift valve is stuck
- (2) If there is no 2 → 3 up-shift:
- No.1 solenoid is stuck
 - 2-3 shift valve is stuck
- (3) If there is no 3 → OD up-shift (throttle valve opening 1/2),
- 3-OD shift valve is stuck
- (4) If the shift point is defective:
- Throttle valve, 1-2 shift valve, 2-3 shift valve, 3-OD shift valve etc., are defective.
- (5) If the lock-up is defective:
- No.3 solenoid is stuck
 - Lock-up relay valve is stuck

- (b) In the same manner, check the shock and the slip at 1 → 2, 2 → 3 and 3 → OD up-shifts.

EVALUATION

If the shock is excessive:

- Line pressure is too high
- Accumulator is defective
- Check ball is defective

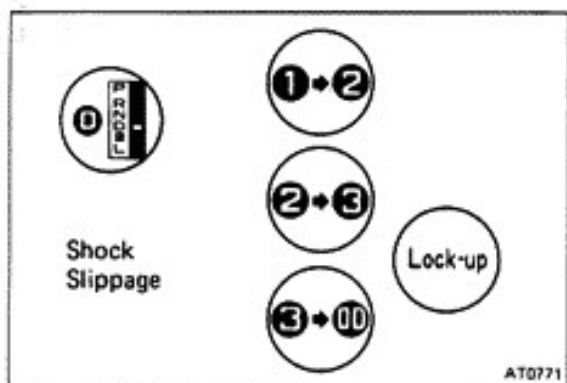

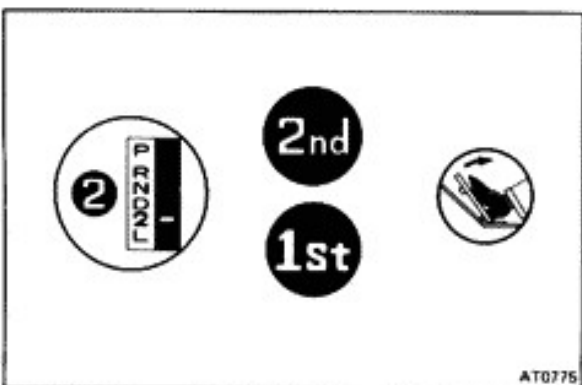
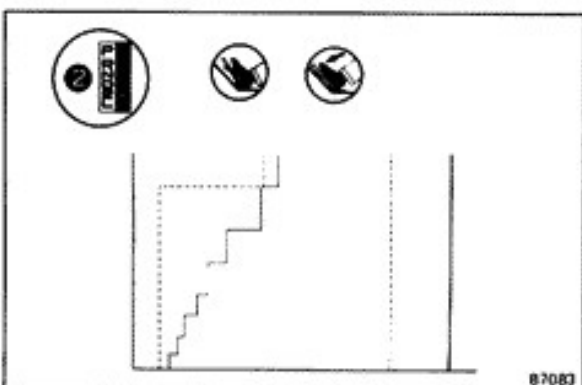
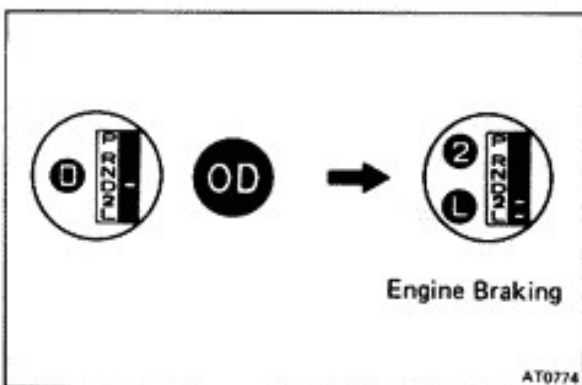
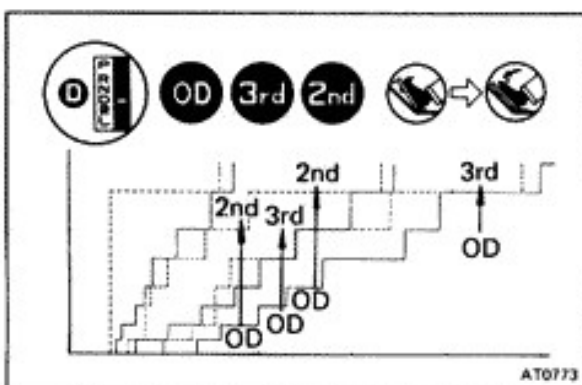
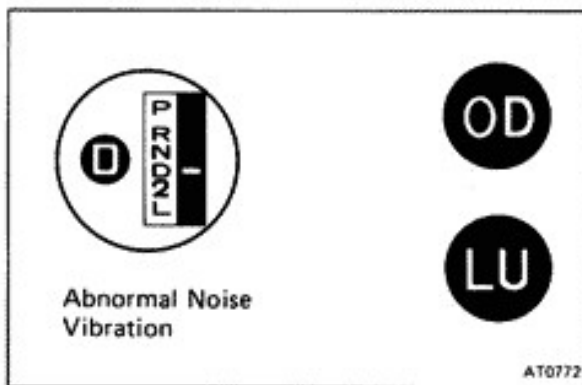

- (c) Run in the OD gear of the "D" range and with the lock-up in operation, and check for abnormal noise or vibration.

NOTE: Check for cause of abnormal noise and vibration must be made with extreme care as they could also be due to unbalance in the propeller shaft, differential, tire, torque converter, etc. or insufficient bending rigidity, etc., in the power train.

- (d) While running in "D" range 2nd, 3rd gears and OD, check to see that the possible kick-down vehicle speed limits for 2 → 1, 3 → 1, 3 → 2, OD → 3 and OD → 2 kick-downs conform to those indicated on the automatic shift diagram.
- (e) Check for abnormal shock and slip at kick-down.

- (f) While running in "D" range OD gear, shift to "2" and "L" ranges and check the engine braking effect at each of these ranges.

EVALUATION

- (1) If there is no engine braking effect at "2" range:
- Brake No. 1 is defective
- (2) If there is no engine braking effect at "L" range:
- Brake No. 3 is defective

2. "2" RANGE TEST, WITH NORM AND PWR PATTERNS

Shift into "2" range and while driving with the accelerator pedal held constant at specified point (throttle valve opening 50 % and 100 %) and push in one of the pattern selectors, check on the following points.

- (a) At each of the above throttle openings, check to see that 1 → 2 up-shift take place and also that the shift points conform to those shown on the automatic shift diagram.

NOTE: There is no OD and no lock-up in "2" range.

- (b) While running in "2" range, 2nd gear, release the accelerator pedal and check the engine braking effect.

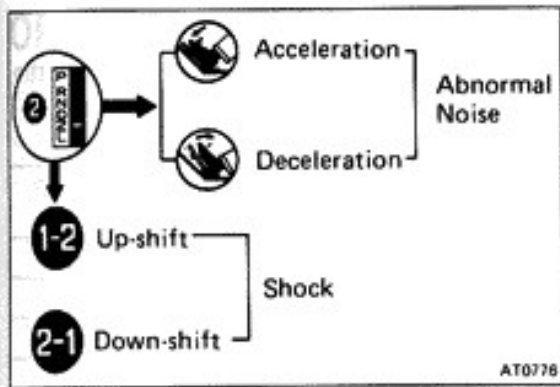

- (c) Check for 2 → 1 down-shift and abnormal noise at acceleration and deceleration, and for shock at up-shift and down-shift.

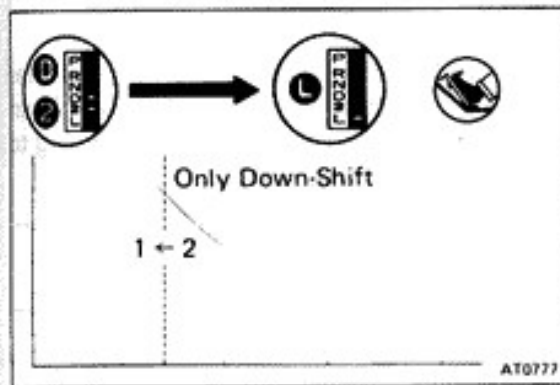

3. "L" RANGE TEST

- (a) While running above 80 km/h (50 mph) in the "D" range, release your foot from the accelerator pedal and shift into "L" range. Then check to see that the 2 → 1 down shift point conforms to 53 km/h (33 mph).

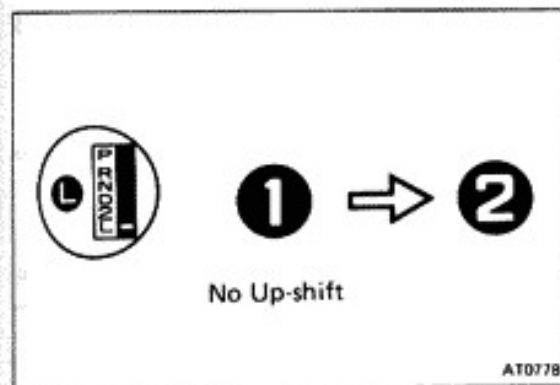

- (b) While running in the "L" range, check to see that there is no up-shift to 2nd gear.

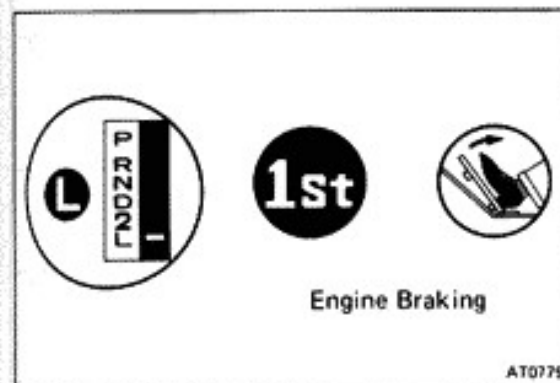

- (c) While running in "L" range, release the accelerator pedal and check the engine braking effect.

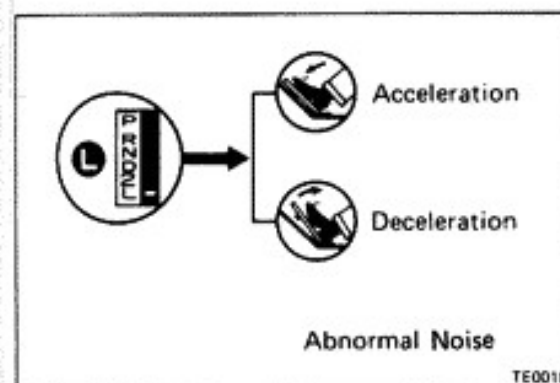

- (d) Check for abnormal noise at acceleration and deceleration.

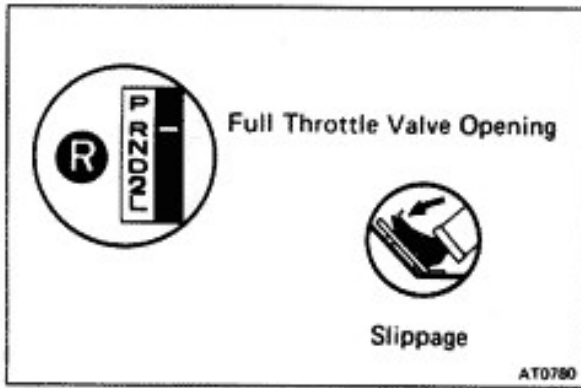
**4. "R" RANGE TEST**

Shift into "R" range and, while starting at full throttle, check for slippage.

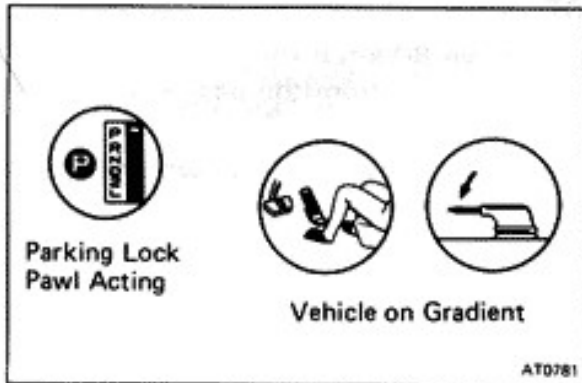
**5. "P" RANGE TEST**

Stop the vehicle on a gradient (more than 9 %) and after shifting into "P" range, release the parking brake. Then check to see that the parking lock pawl is functioning to prevent the vehicle from moving.

OPERATING MECHANISM FOR EACH GEAR

1. TRANSMISSION SYSTEM

○ Operating

| Shift lever position | Gear position | C ₀ | C ₁ | C ₂ | | B ₀ | B ₁ | B ₂ | B ₃ | | F ₀ | F ₁ | F ₂ |
|----------------------|---------------|----------------|----------------|----------------|-----|----------------|----------------|----------------|----------------|-----|----------------|----------------|----------------|
| | | | | I.P | O.P | | | | I.P | O.P | | | |
| P | Parking | ○ | | | | | | | | | | | |
| R | Reverse | ○ | | ○ | ○ | | | | ○ | ○ | | | |
| N | Neutral | ○ | | | | | | | | | | | |
| D | 1st | ○ | ○ | | | | | | | | ○ | | ○ |
| | 2nd | ○ | ○ | | | | | ○ | | | ○ | ○ | |
| | 3rd | ○ | ○ | | ○ | | | ○ | | | ○ | | |
| | OD | | ○ | | ○ | ○ | | ○ | | | | | |
| 2 | 1st | ○ | ○ | | | | | | | | ○ | | |
| | 2nd | ○ | ○ | | | | ○ | ○ | | | ○ | ○ | |
| | 3rd | ○ | ○ | | ○ | | | ○ | | | ○ | | |
| L | 1st | ○ | ○ | | | | | | ○ | ○ | ○ | | ○ |
| | *2nd | ○ | ○ | | | | ○ | ○ | | | ○ | ○ | |

* Down shift only in "L" range, 2nd gear – no up shift.

2. SOLENOID SYSTEM

Possible gear positions in accordance with solenoid operating conditions.

| Range | NORMAL | | | SOLENOID NO. 1 MALFUNCTIONING | | | SOLENOID NO. 2 MALFUNCTIONING | | | BOTH SOLENOIDS MALFUNCTIONING | | |
|-----------|----------------|------|---------------|-------------------------------|----------|---------------|-------------------------------|------|---------------|-------------------------------|------|---------------|
| | Solenoid valve | | Gear Position | Solenoid valve | | Gear Position | Solenoid valve | | Gear Position | Solenoid valve | | Gear Position |
| | No.1 | No.2 | | No.1 | No.2 | | No.1 | No.2 | | No.1 | No.2 | |
| "D" range | ON | OFF | 1st | X | ON (OFF) | 3rd (OD) | ON | X | 1st | X | X | OD |
| | ON | ON | 2nd | X | ON | 3rd | OFF (ON) | X | OD (1st) | X | X | OD |
| | OFF | ON | 3rd | X | ON | 3rd | OFF | X | OD | X | X | OD |
| | OFF | OFF | OD | X | OFF | OD | OFF | X | OD | X | X | OD |
| "2" range | ON | OFF | 1st | X | ON (OFF) | 3rd (OD) | ON | X | 1st | X | X | 3rd |
| | ON | ON | 2nd | X | ON | 3rd | OFF (ON) | X | 3rd (1st) | X | X | 3rd |
| | OFF | ON | 3rd | X | ON | 3rd | OFF | X | 3rd | X | X | 3rd |
| "L" range | ON | OFF | 1st | X | OFF | 1st | ON | X | 1st | X | X | 1st |
| | ON | ON | 2nd | X | ON | 2nd | ON | X | 1st | X | X | 1st |

| : No fail safe function

X: Malfunctions

AUTOMATIC SHIFT DIAGRAM

| | | Throttle valve fully open [] Fully closed | | | | | | | km/h (mph) | |
|---------|-------------|--|--------------------|---------------------|--------------------|--------------------|--------------------|--------------------|------------------|--|
| | | 1-2 | 2-3 | 3-OD | [3-OD] | [OD-3] | OD-3 | 3-2 | 2-1 | |
| D range | NORM | 47-52 (29-32) | 92-101 (57-63) | 135-144 (84-89) | [36-40] (22-25) | [26-30] (16-19) | 130-138 (81-86) | 88-96 (55-60) | 42-47 (26-29) | |
| | PWR | 52-57 (32-35) | 105-114 (65-71) | 152-161 (94-100) | [42-46] (26-29) | [28-32] (17-20) | 146-155 (91-96) | 101-109 (63-68) | 42-47 (26-29) | |
| 2 range | NORM PWR | 47-52 (29-32) | 112-121 (70-75) | - | - | - | - | 102-110 (63-68) | 42-47 (26-29) | |
| L range | NORM PWR | - | - | - | - | - | - | - | 51-55 (32-34) | |

| | | Throttle valve opening 5 % km/h (mph) | | | | | |
|---------|-------------|---------------------------------------|------------------|------------------|-------------|------------------|------------------|
| | | Lock-up ON | | | Lock-up OFF | | |
| | | 2nd | 3rd (*) | OD | 2nd | 3rd (*) | OD |
| D range | NORM PWR | - | 53-58 (33-36) | 53-58 (33-36) | - | 49-54 (30-34) | 49-54 (30-34) |
| 2 range | NORM PWR | - | - | - | - | - | - |
| L range | NORM PWR | - | - | - | - | - | - |

(*): OD switch OFF

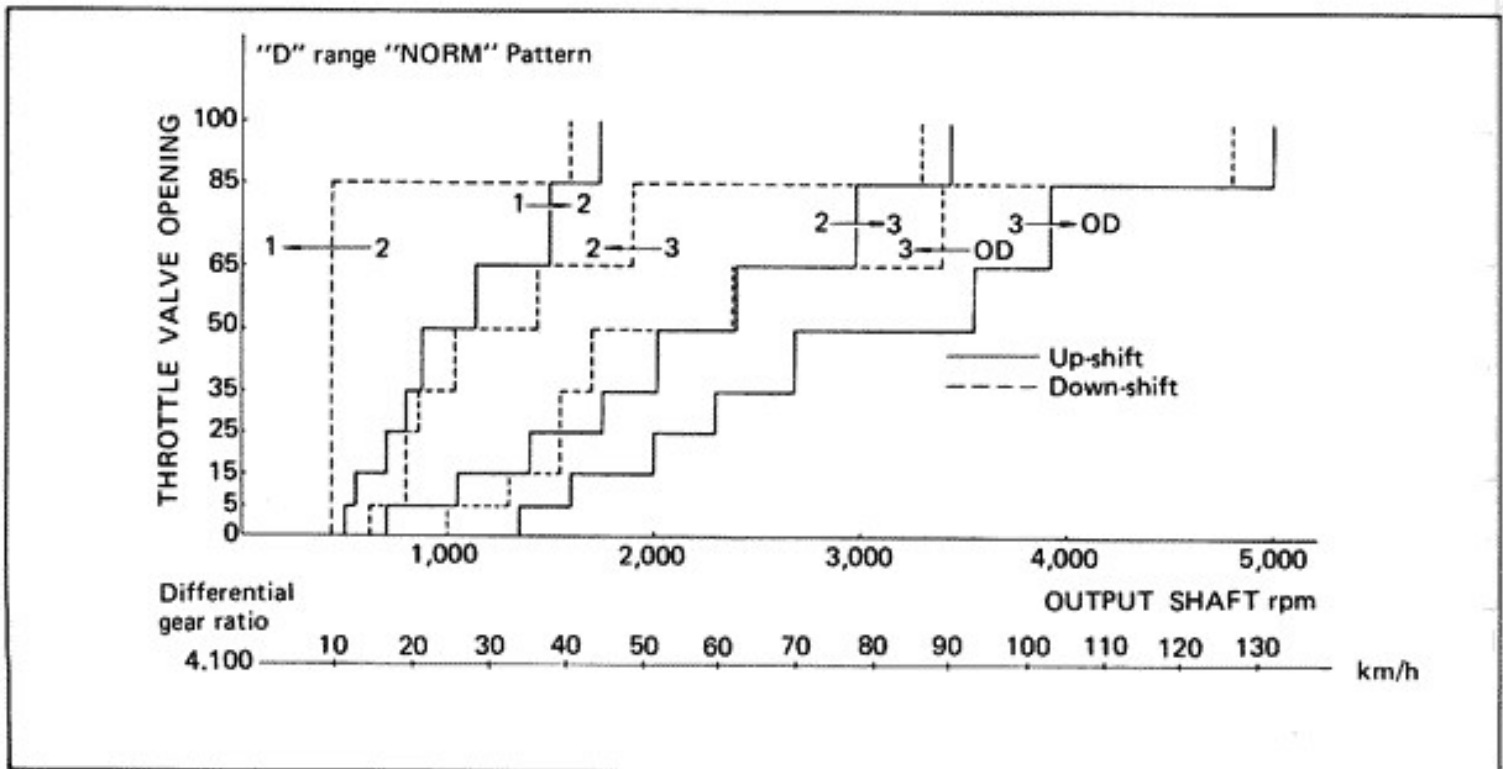

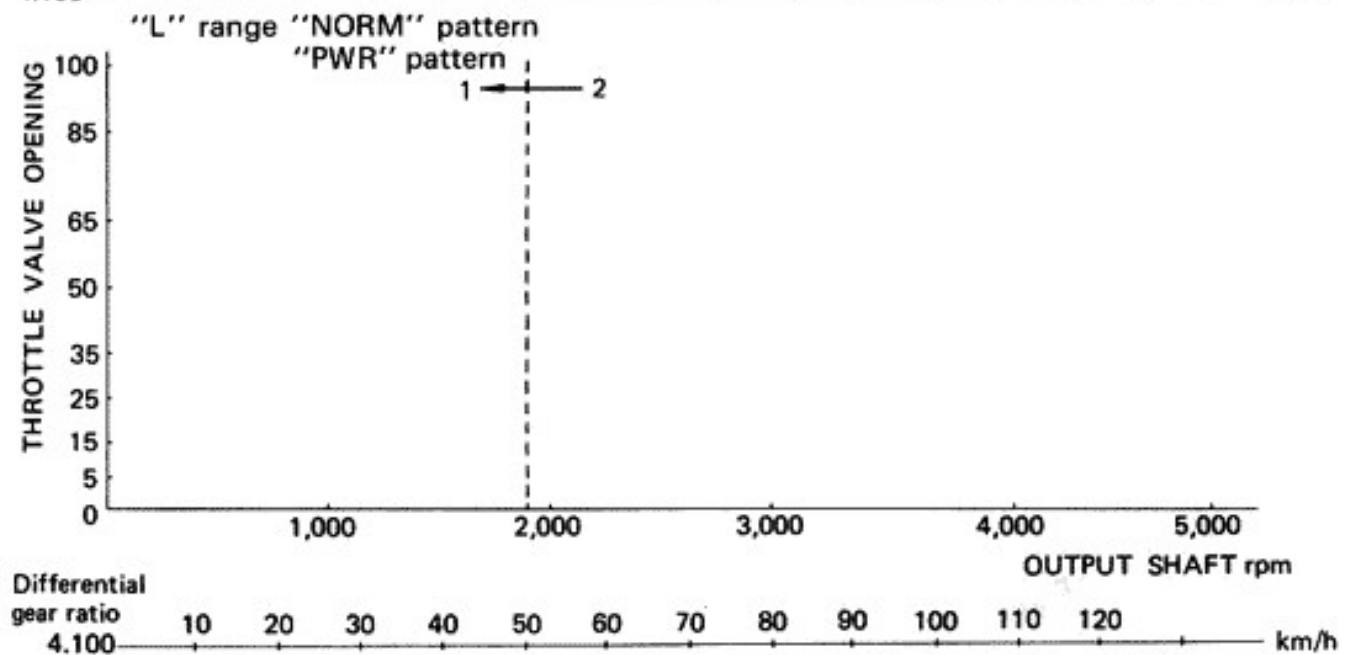
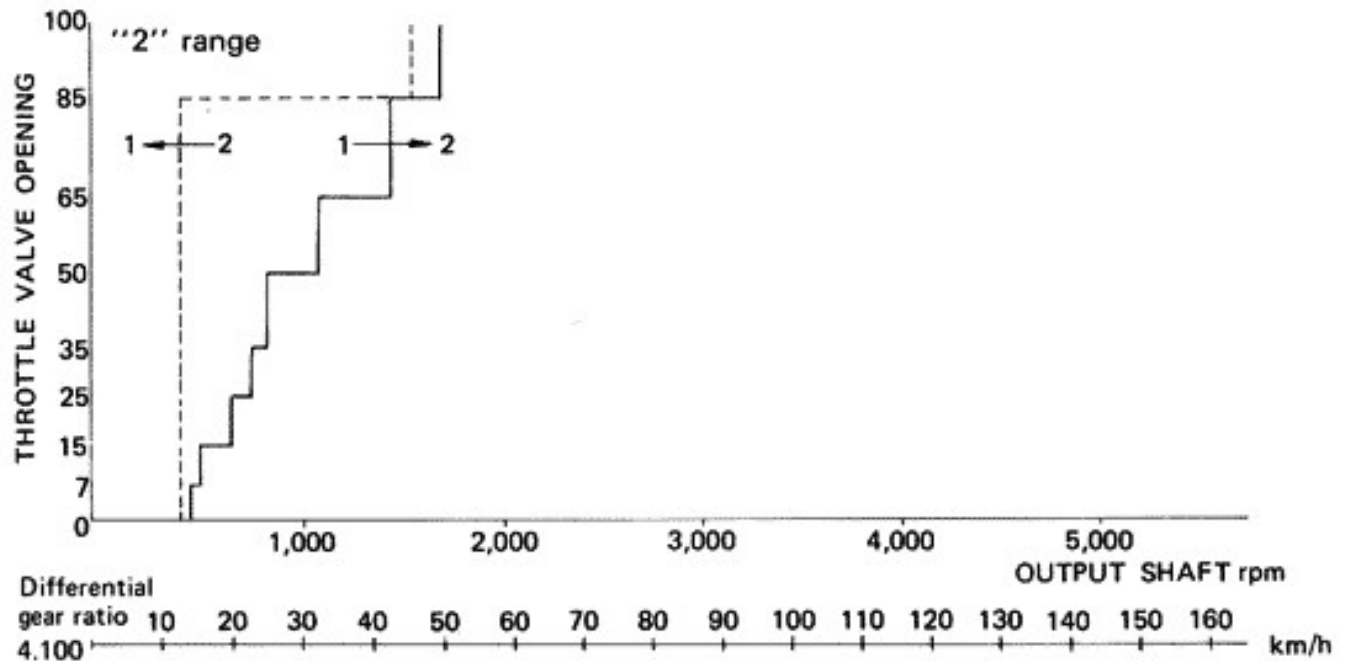
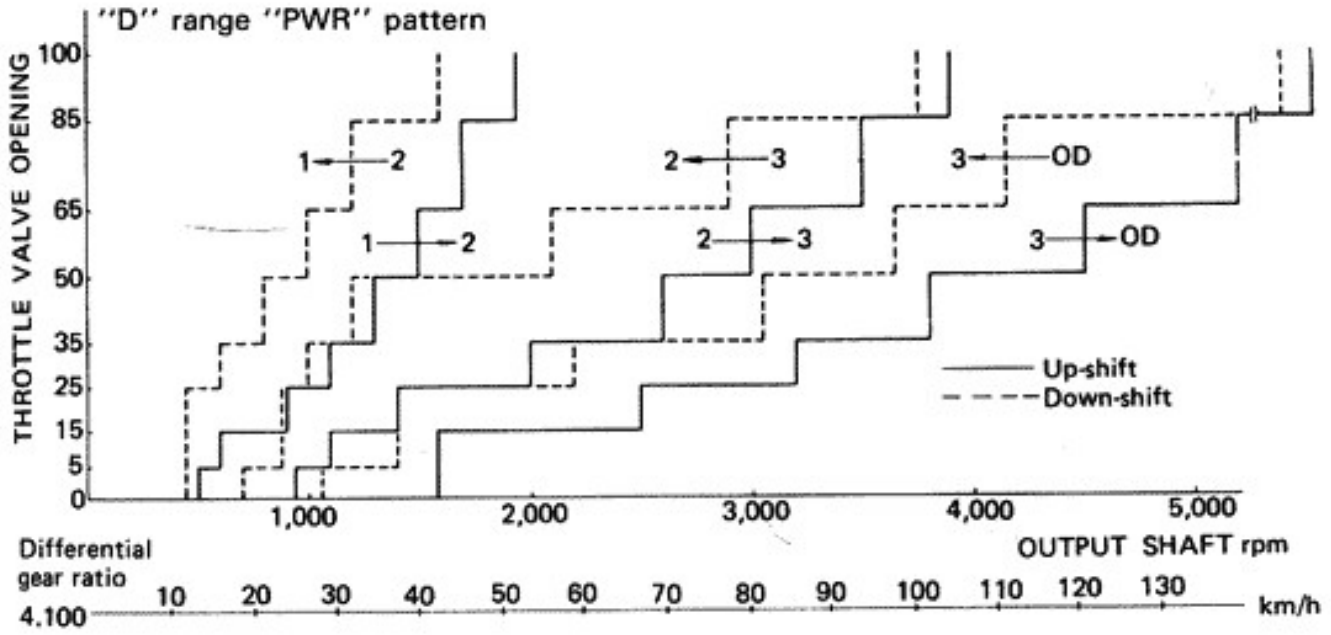

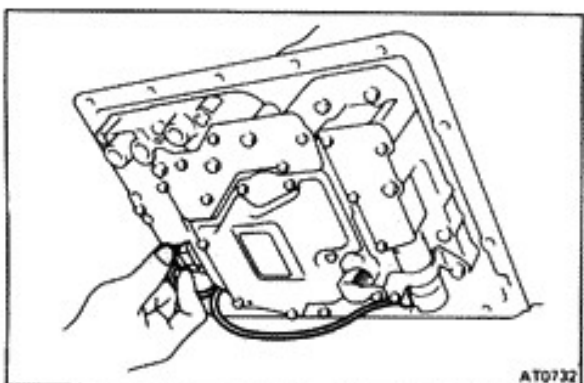
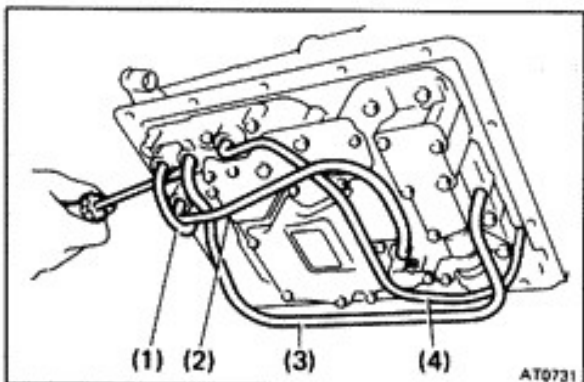
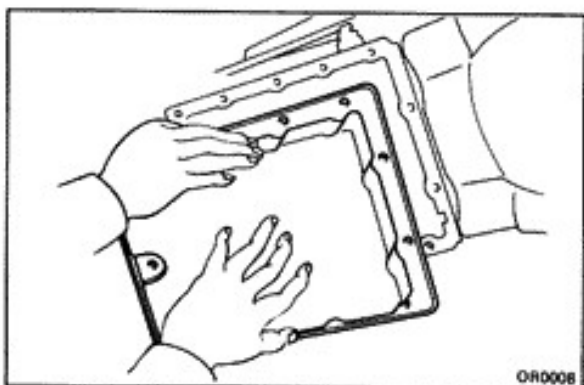
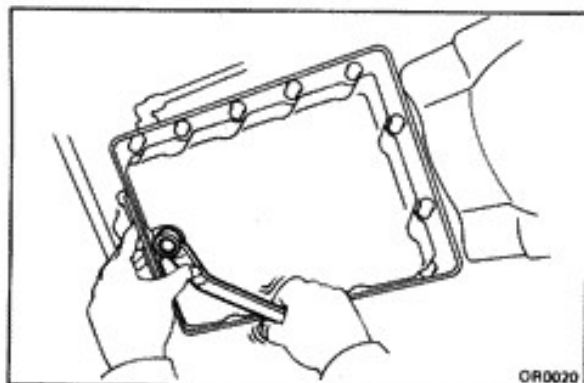
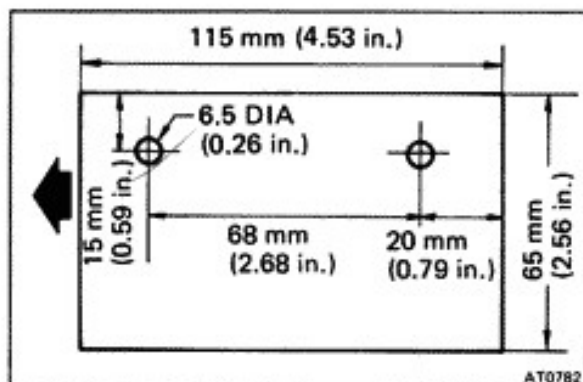

ON-VEHICLE REPAIR

REMOVAL OF SOLENOID OR VALVE BODY

1. MAKE PLATE TO RETAIN ACCUMULATOR PISTONS

A retainer is helpful for holding accumulator pistons in the case during removal and installation of the valve body.

The plate may be made from aluminum or plastic.

2. CLEAN TRANSMISSION EXTERIOR

To help prevent contamination, clean the exterior of the transmission.

3. DRAIN TRANSMISSION FLUID

Remove the drain plug and drain fluid into a suitable container.

4. REMOVE OIL PAN, FILLER TUBE AND GASKET

CAUTION: Some fluid will remain in the oil pan. Be careful not to damage the filler tube and O-ring.

Remove all pan bolts, and carefully remove the pan assembly. Discard the gasket.

5. REMOVE OIL TUBES

- Remove the four tubes in the numerical order shown.
- Pry up both tube ends with a large screwdriver and remove the tubes.

6. DISCONNECT TWO CONNECTORS FROM SOLENOID

- Disconnect the solenoid wire from clamp.
- Disconnect the two connectors.

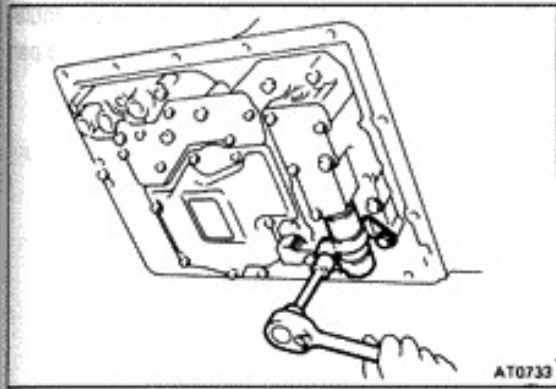

7. WHEN REPLACING SOLENOID

- (a) For the No. 3 solenoid,
 - (1) Remove the two bolts.
 - (2) Remove the solenoid.

- (b) For the No. 1 and 2 solenoids,
 - (1) Remove the three bolts.
 - (2) Remove the solenoid with gasket.

NOTE: Be careful not to remove the two valve springs.

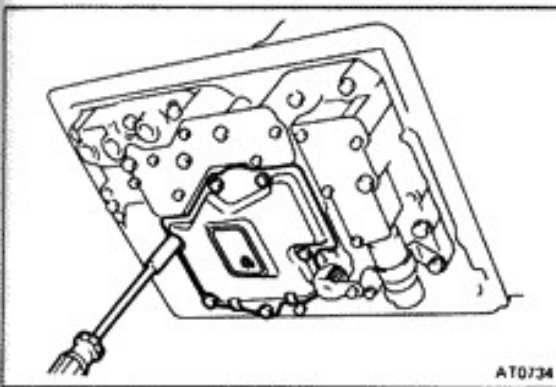

8. REMOVE OIL STRAINER

Remove the six bolts, and the oil strainer.

CAUTION: Be careful as some oil will come out with the oil strainer.

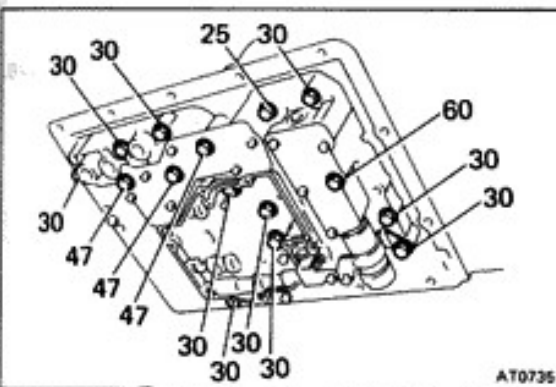

9. REMOVE VALVE BODY

- (a) Remove the fifteen bolts.

- (b) Remove the B₂ and C₂ accumulator piston springs.

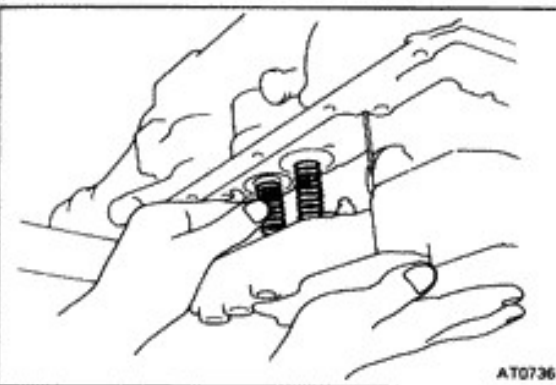

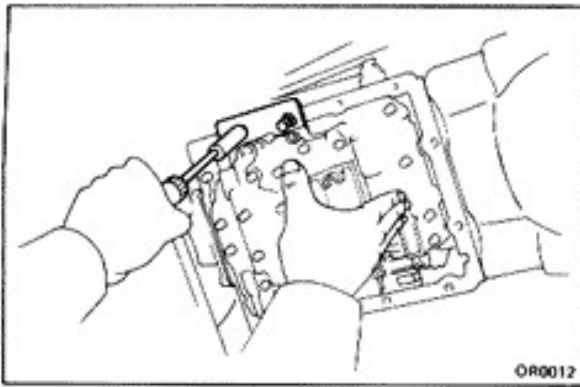

- (c) Lower valve body slightly, and install the accumulator piston retaining plate. Hold in place with two pan bolts, finger tight.

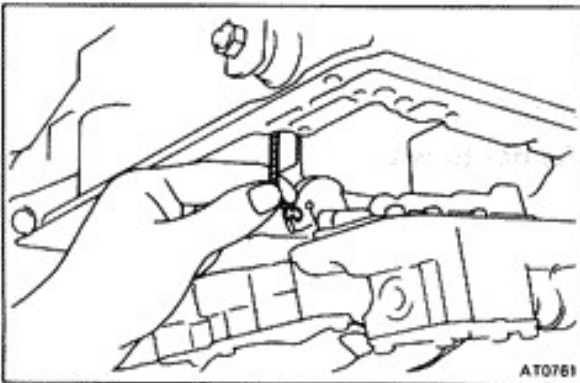

- (d) Disconnect the throttle cable from the cam and remove the valve body.

DISASSEMBLY, INSPECTION AND ASSEMBLY OF VALVE BODY

(See page AT-83)

INSTALLATION OF VALVE BODY

1. CONNECT THROTTLE CABLE TO CAM

Push the cable fitting into the cam.

2. REMOVE ACCUMULATOR RETAINING PLATE

Remove the two pan bolts, and slide out the plate.

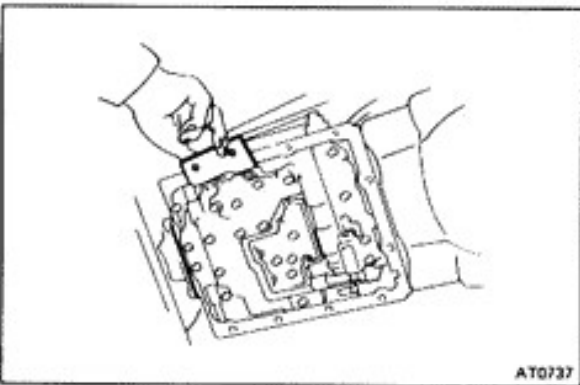

3. INSTALL VALVE BODY

- (a) Align the manual valve lever with the manual valve.

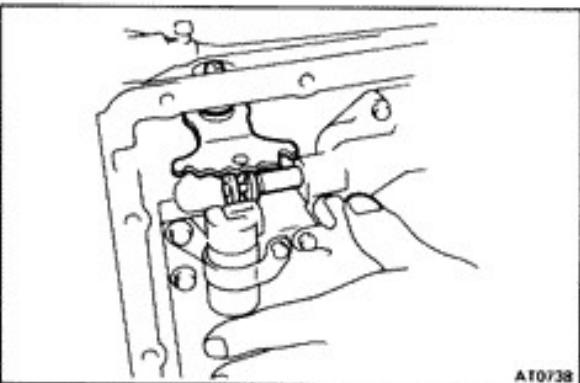

- (b) Install the B₂ and C₂ accumulator piston springs.

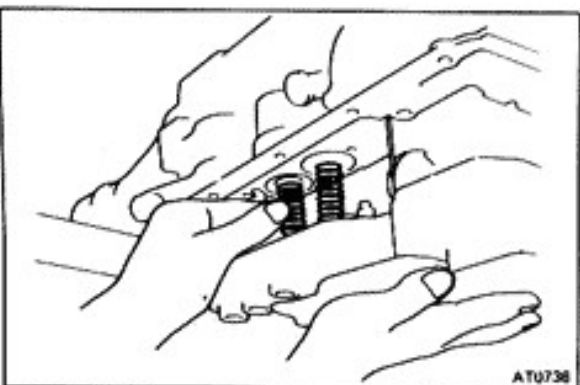

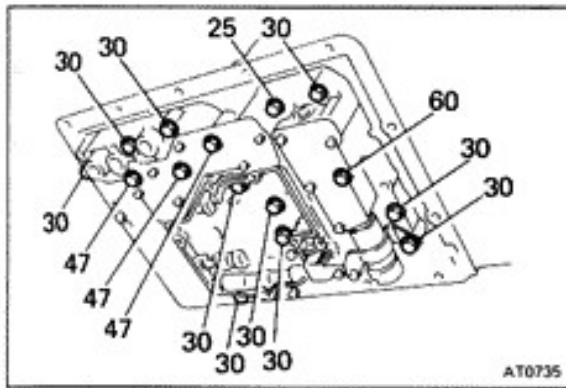

4. INSTALL VALVE BODY BOLTS

Install the bolts as shown. Tighten the bolts evenly.

Torque: 100 kg-cm (7 ft-lb, 10 N·m)

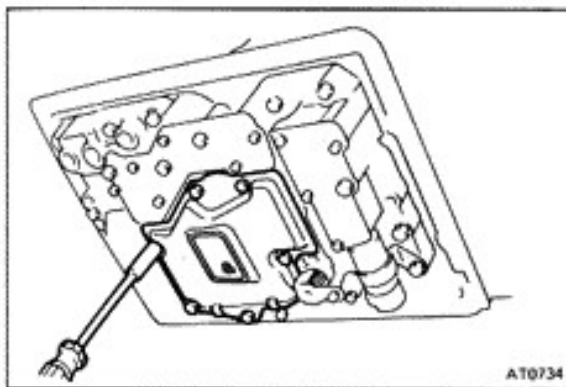

5. INSTALL OIL STRAINER

Be sure the strainer is clean. Torque the six bolts.

Torque: 55 kg-cm (48 in.-lb, 5.4 N·m)

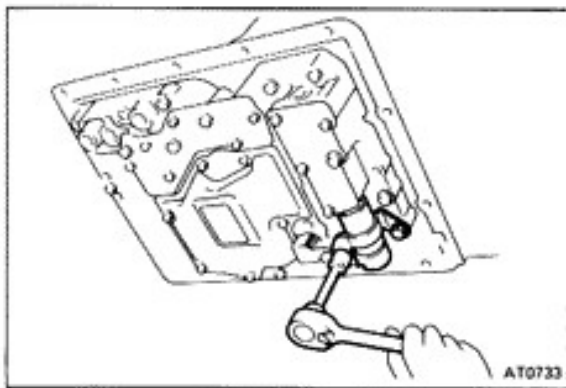

6. WHEN REPLACING SOLENOID

(a) For the No. 3 solenoid,

- Install the solenoid into the bore.
- Tighten the two bolts.

Torque: 55 kg-cm (48 in.-lb, 5.4 N·m)

(b) For the No. 1 and 2 solenoids,

- Make sure that the two valve spring are installed correctly.
- Install the solenoid over the gasket and install the center of the bolt.
- Tighten the three bolts.

Torque: 100 kg-cm (7 ft-lb, 10 N·m)

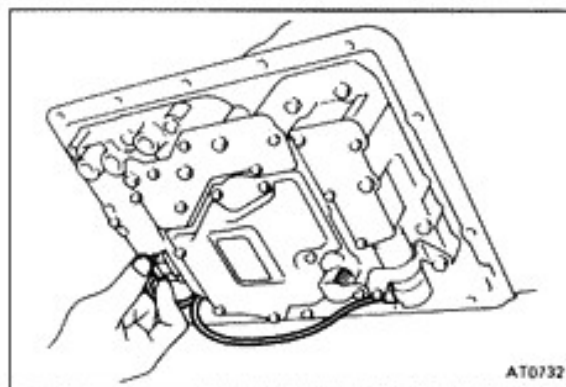

7. CONNECT TWO CONNECTORS TO EACH SOLENOID

(a) Connect the two connectors to each solenoid.

(b) Clamp the solenoid wire.

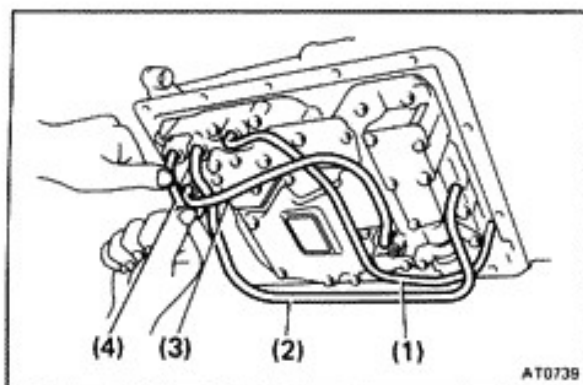

8. INSTALL FOUR OIL TUBES

Press the tubes by hand into the positions indicated in numerical order shown.

CAUTION: Make sure that the oil tubes or the two magnets do not interfere with the oil pan.

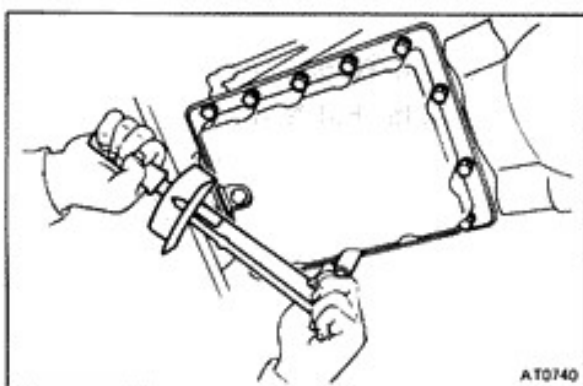

9. INSTALL PAN WITH NEW GASKET

Be sure the pan is clean and the two magnets are in place.

CAUTION: Do not use gasket sealer.

Tighten the bolts evenly.

Torque: 45 kg-cm (39 in.-lb, 4.4 N·m)

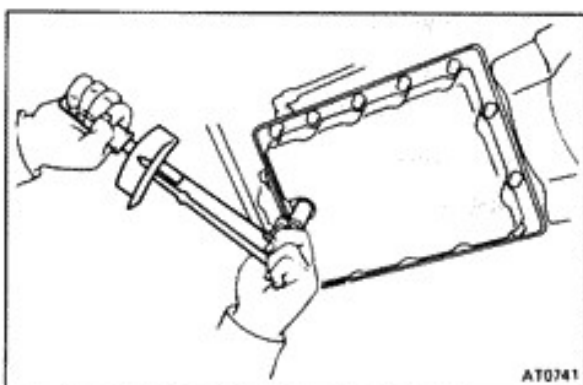

10. INSTALL DRAIN PLUG

Torque the drain plug.

Torque: 205 kg-cm (15 ft-lb, 20 N·m)

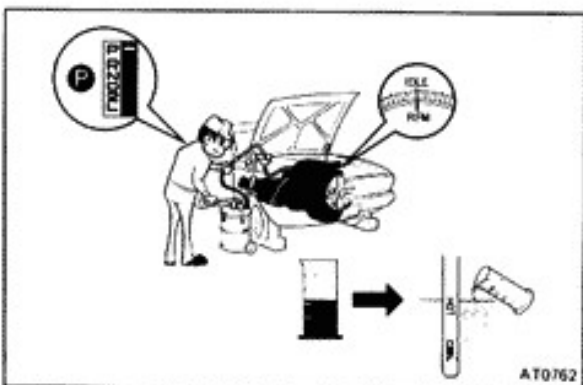

11. FILL TRANSMISSION WITH ATF

Add only about four quarts of ATF.

CAUTION: Do not overfill.

Fluid type: ATF DEXRON® II

12. CHECK FLUID LEVEL

(See page MA-13)

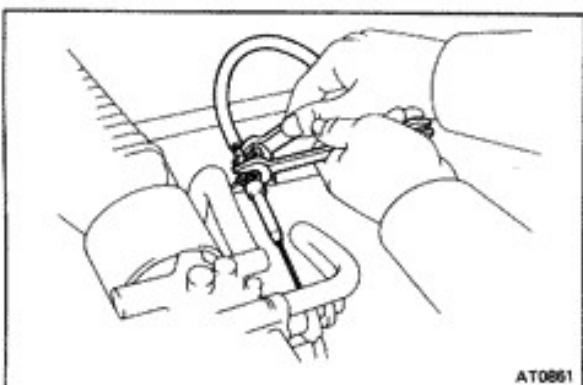

REMOVAL OF THROTTLE CABLE

1. REMOVAL AIR CLEANER

2. DISCONNECT THROTTLE CABLE

- (a) Disconnect the cable housing from the bracket on the cylinder head cover.
- (b) Disconnect the cable from the throttle linkage.

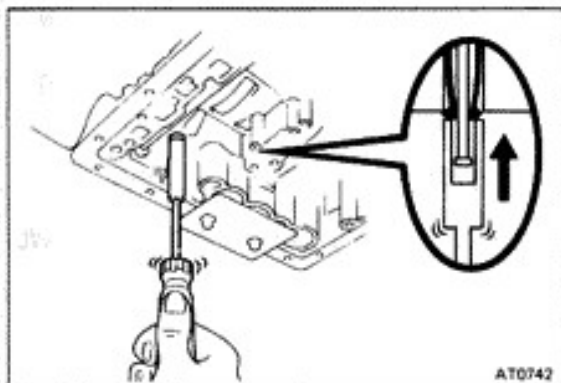

3. REMOVE VALVE BODY (See page AT-32)
4. PUSH THROTTLE CABLE OUT OF TRANSMISSION CASE
Using a 10-mm socket, push the throttle cable out.

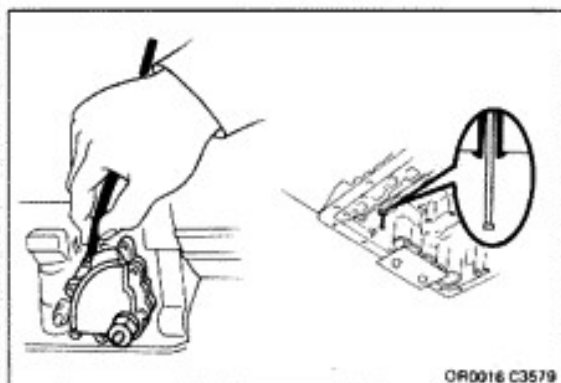

INSTALLATION OF THROTTLE CABLE

1. INSTALL CABLE IN TRANSMISSION CASE
Be sure to push it in all the way.
2. INSTALL VALVE BODY (See page AT-34)

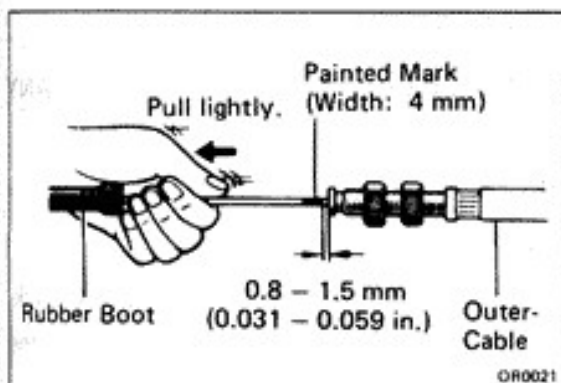

3. IF THROTTLE CABLE IS NEW, PAINT MARK ON INNER CABLE

NOTE: New cables do not have a cable stopper installed. Therefore, to make adjustment possible, paint a mark as described below.

- (a) Pull the inner cable lightly until slight resistance is felt, and hold it.
- (b) Paint a mark as shown, about 4 mm (0.16 in.) in width.

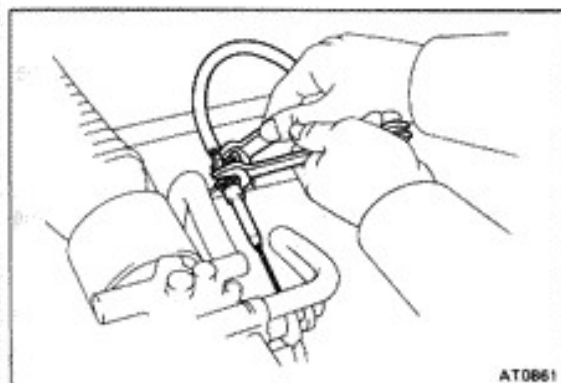

4. CONNECT THROTTLE CABLE
 - (a) Connect the cable to the throttle linkage.
 - (b) Connect the cable housing to the bracket on the valve cover.
5. ADJUST THROTTLE CABLE (See page AT-5)
6. INSTALL AIR CLEANER
7. TEST DRIVE VEHICLE

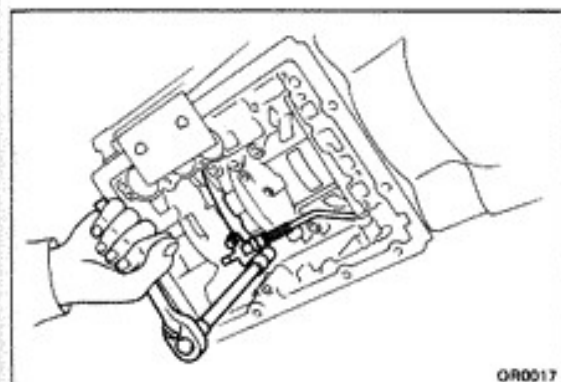

REMOVAL OF PARKING LOCK PAWL

1. REMOVE VALVE BODY (See page AT-32)
2. REMOVE PARKING LOCK PAWL BRACKET
Remove the two bolts and the bracket.

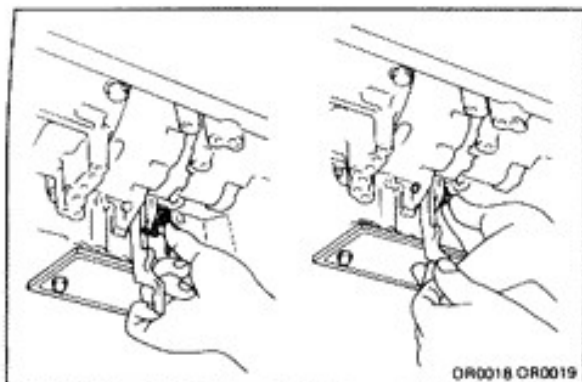

3. REMOVE SPRING FROM PARKING PAWL PIVOT PIN
4. REMOVE PARKING PAWL PIVOT PIN AND PARKING LOCK PAWL

INSTALLATION OF PARKING LOCK PAWL

1. INSTALL PARKING LOCK PAWL AND PARKING PAWL PIVOT PIN
2. INSTALL PIVOT SPRING

3. INSTALL PARKING LOCK PAWL BRACKET

- (a) Push lock rod fully forward.
- (b) Install two bolts finger tight.
- (c) Check that the parking lock pawl operates smoothly.
- (d) Torque the bolts.

Torque: 75 kg-cm (65 in.-lb, 7.4 N·m)

4. INSTALL VALVE BODY (See page AT-34)

REMOVAL OF EXTENSION HOUSING

1. RAISE VEHICLE AND POSITION PAN TO CATCH ANY FLUID THAT MAY DRIP

2. REMOVE PROPELLER SHAFT

3. JACK UP TRANSMISSION SLIGHTLY

Securely support the transmission on a transmission jack. Lift the transmission slightly to remove weight from the rear support member.

4. DISCONNECT SPEEDOMETER CABLE

Loosen the serrated collar with pliers. Do not lose the felt dust protector and washer.

5. REMOVE SPEEDOMETER DRIVEN GEAR

Remove one bolt and locking tab. Pry out the speedometer driven gear with a screwdriver.

6. REMOVE SPEED SENSOR

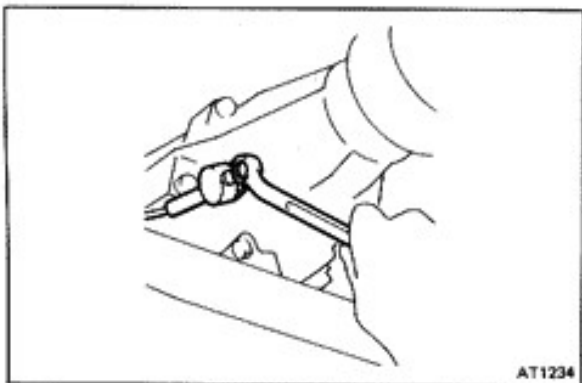
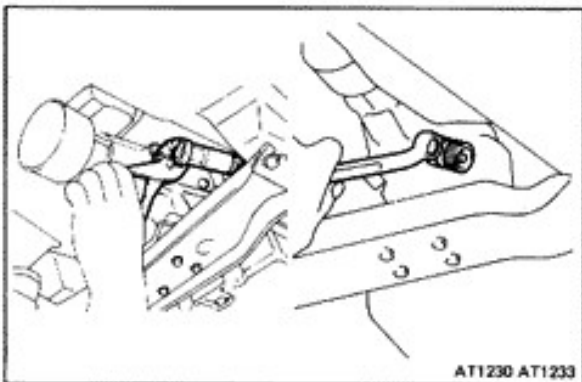
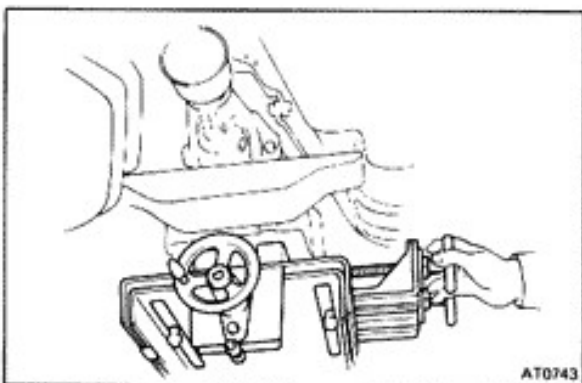
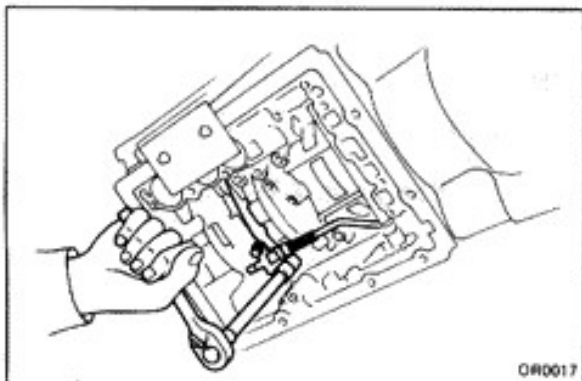

7. REMOVE REAR SUPPORT MEMBER

- (a) Remove the ground strap and the rubber exhaust hanger.

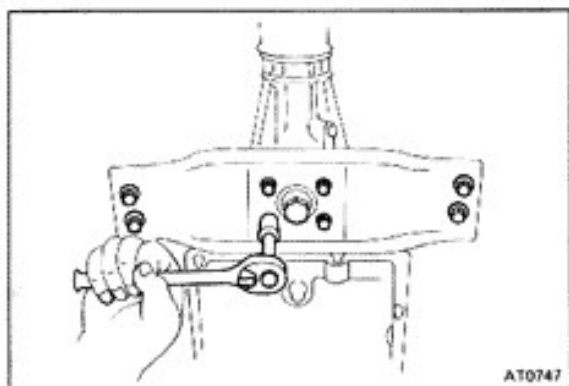

- (b) Remove the eight bolts and support.

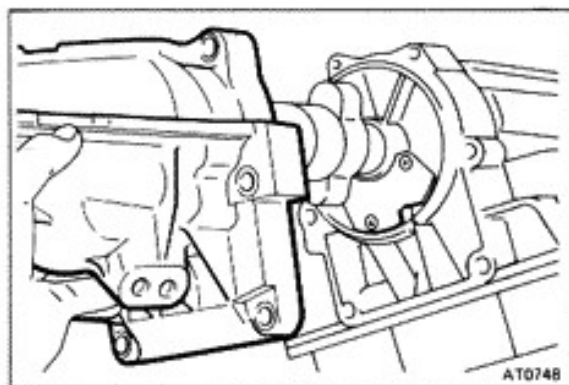
**8. REMOVE EXTENSION HOUSING AND GASKET**

Remove the six bolts. If necessary, tap the extension housing with a soft-faced hammer or block of wood to loosen it.

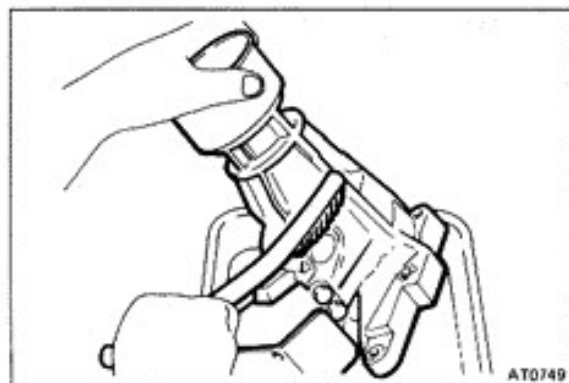
**9. CLEAN AND INSPECT COMPONENTS**

- (a) Wash components in clean solvent, and dry with compressed air.
- (b) Check the case, speedometer gear and output shaft for cracks, wear or damage.

INSTALLATION OF EXTENSION HOUSING

NOTE: If necessary, install a new oil seal before installation. (See page AT-103)

1. INSTALL NEW GASKET AND EXTENSION HOUSING ON TRANSMISSION

Install the six bolts finger tight, then torque them.

NOTE: The two lower bolts are shorter.

Torque: 345 kg-cm (25 ft-lb, 34 N·m)

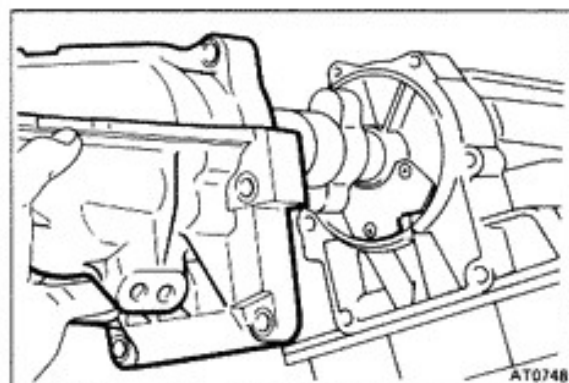

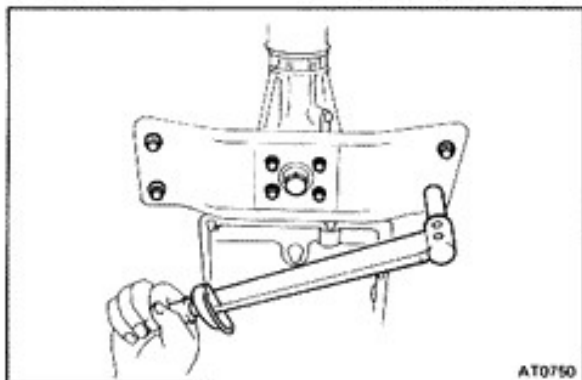

2. INSTALL REAR SUPPORT MEMBER

- (a) Install the support member to the chassis and lower the transmission to allow installation of the center bolts.
- (b) Install the ground strap and rubber exhaust hanger.

3. INSTALL PROPELLER SHAFT

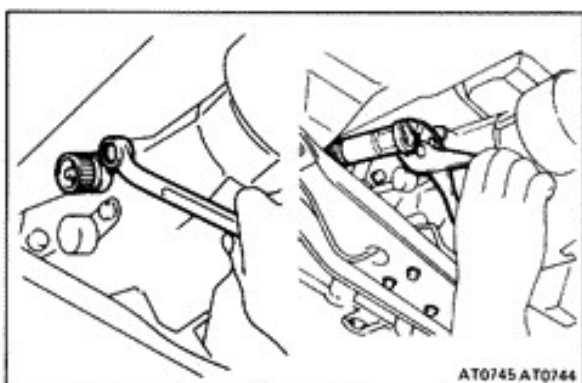

4. INSTALL SPEED SENSOR

5. INSTALL SPEEDOMETER DRIVEN GEAR

- (a) Install a new O-ring on the shaft sleeve.
- (b) Install the lock plate with a bolt and washer.

6. CONNECT SPEEDOMETER CABLE

Place the felt dust protector and washer on the end of the cable. Tighten the collar with pliers.

7. LOWER VEHICLE AND CHECK FLUID LEVEL (See page MA-13)

Start the engine, shift the selector into each gear, then check the fluid level with the transmission in "P" range. Add fluid as necessary.

CAUTION: Do not overfill.

Fluid type: ATF DEXRON® II

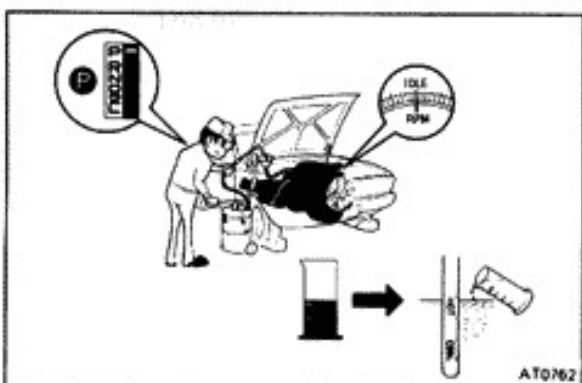

REMOVAL OF ROTOR SENSOR

1. REMOVE EXTENSION HOUSING (See page AT-38)

2. REMOVE SPEEDOMETER DRIVE GEAR

- (a) Using snap ring pliers, remove the snap ring.
- (b) Slide off the speedometer gear.
- (c) Remove the lock ball.

3. REMOVE ROTOR SENSOR FROM OUTPUT SHAFT

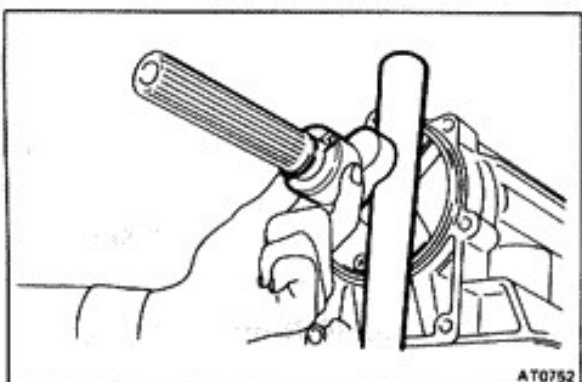
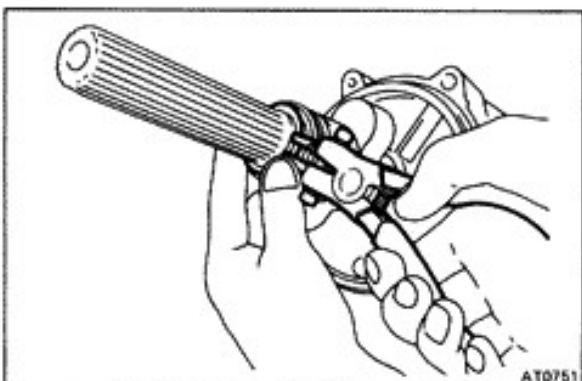

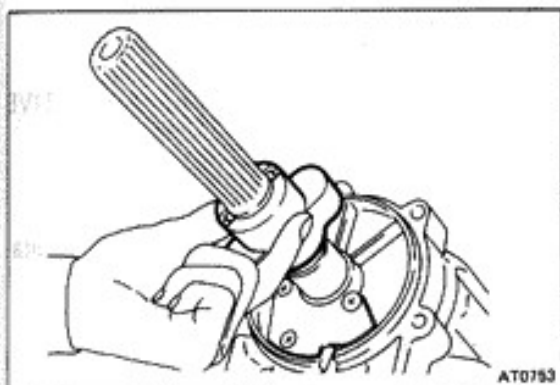

INSTALLATION OF ROTOR SENSOR

1. **INSTALL ROTOR SENSOR ON OUTPUT SHAFT**
 - (a) Make sure that the key is installed in the groove.
 - (b) Install the rotor sensor on the shaft.

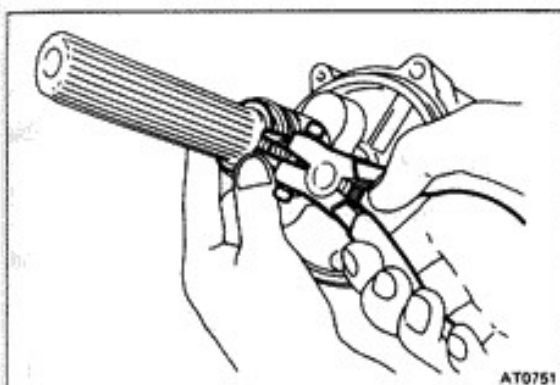

2. **INSTALL SPEEDOMETER DRIVE GEAR**
 - (a) Slide the lock ball and the speedometer gear on the shaft.
 - (b) Using snap ring pliers, install the outer snap ring.
3. **INSTALL EXTENSION HOUSING (See page AT-39)**

REPLACEMENT OF REAR OIL SEAL

1. **RAISE VEHICLE, AND POSITION PAN TO CATCH ANY FLUID THAT MAY DRIP**
2. **REMOVE PROPELLER SHAFT**

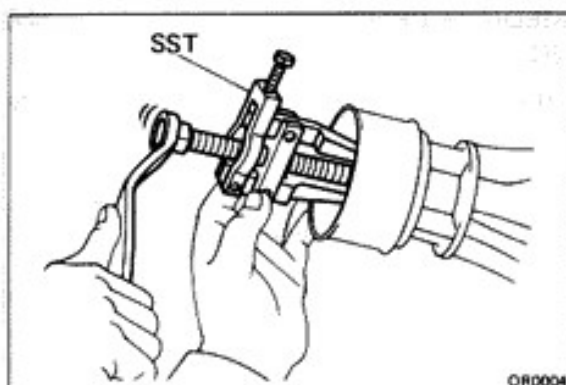

3. **REMOVE REAR DUST SEAL AND OIL SEAL**
CAUTION: Clean the rear extension housing before removing the seal.
 Using SST, remove the two seals.
 SST 09308-10010

4. **INSTALL NEW OIL SEAL AND DUST SEAL**
 Using SST, drive in the oil seal as far as it will go.
 Drive in the dust seal flush with the housing.
 SST 09325-20010

5. **INSTALL PROPELLER SHAFT**

6. **LOWER VEHICLE AND CHECK FLUID LEVEL**
 (See page MA-13)

Start the engine, shift the selector into each gear, then check the fluid level with the transmission in "P" range. Add fluid as necessary.

Fluid type: **ATF DEXRON® II**

CAUTION: Do not overfill.

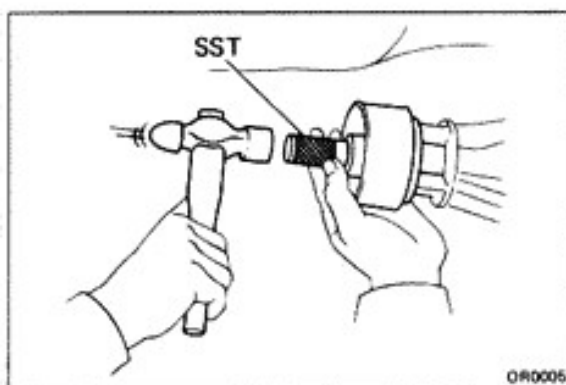

REMOVAL OF TRANSMISSION

1. **DISCONNECT BATTERY CABLE FROM NEGATIVE TERMINAL**

2. **DRAIN COOLANT**

Open the radiator drain cock and drain coolant into a suitable container.

3. **DISCONNECT UPPER RADIATOR HOSE**

4. **DISCONNECT AIR INTAKE CONNECTOR**

5. **DISCONNECT TRANSMISSION THROTTLE CABLE**

(a) Loosen the adjusting nuts, and disconnect the cable housing from the bracket.

(b) Disconnect the cable from the throttle linkage.

(c) Disconnect the throttle cable from the engine rear end.

6. **RAISE VEHICLE AND DRAIN TRANSMISSION**

CAUTION: Be sure the vehicle is securely supported.

7. **DISCONNECT THREE WIRING CONNECTORS**

Disconnect the three connectors located near the starter.

8. **REMOVE INTERMEDIATE PROPELLER SHAFT TOGETHER CENTER BEARING**

(a) Disconnect the propeller shaft from the intermediate shaft.

(b) Remove the center bearing.

(c) Remove the intermediate shaft.

9. **DISCONNECT EXHAUST PIPE FROM TAIL PIPE**

(a) Disconnect the pipe at the rear side of the converter.

(b) Remove the two rubber hangers.

(c) Remove the pipe clamp from the transmission case.

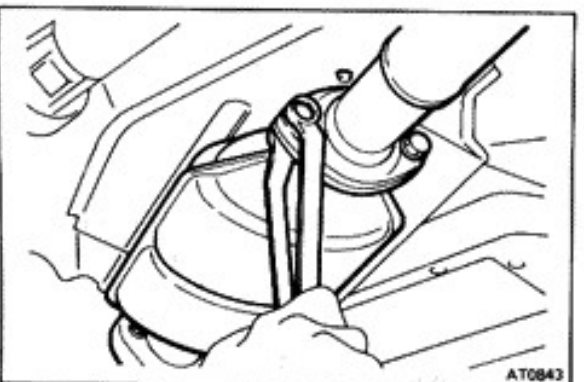
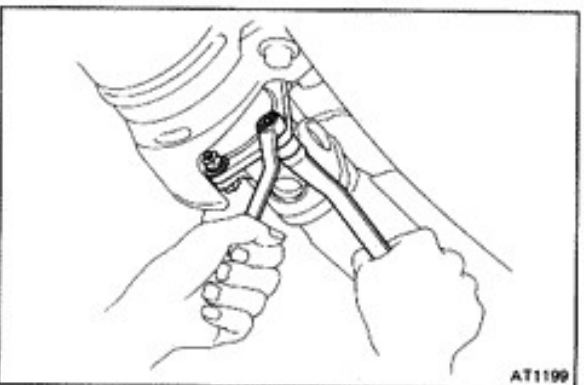
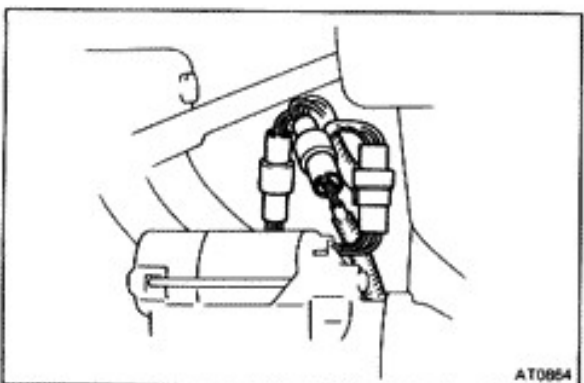
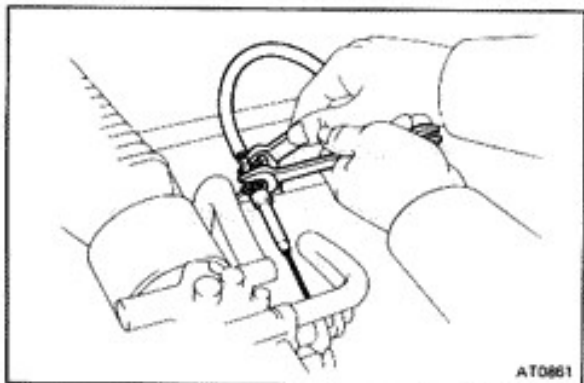
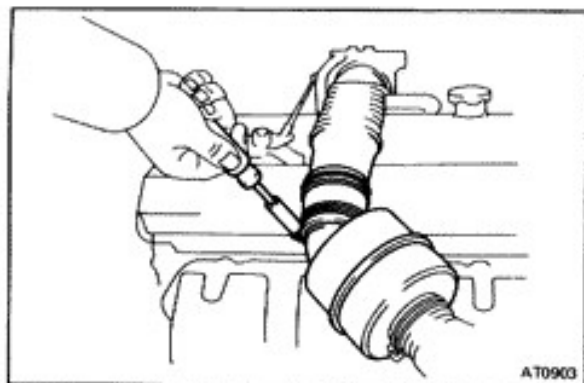

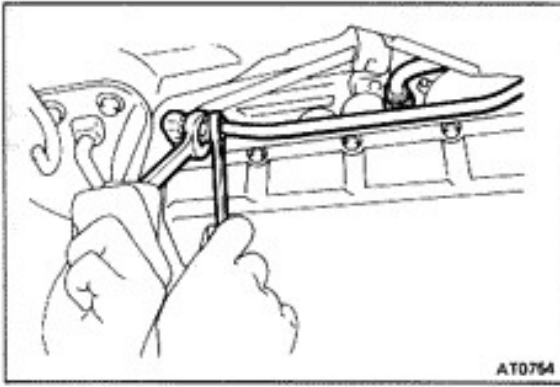
**10. DISCONNECT TWO OIL COOLER LINES**

- (a) Remove the oil cooler pipe clamp from the transmission case.
- (b) Disconnect the two oil cooler pipes from the transmission case.

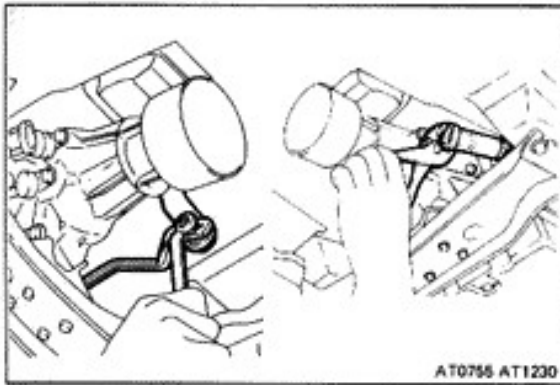
**11. DISCONNECT MANUAL SHIFT LINKAGE**

Disconnect the shift linkage at the rear connection.

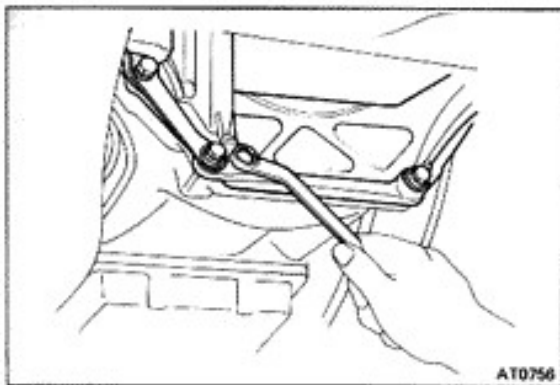
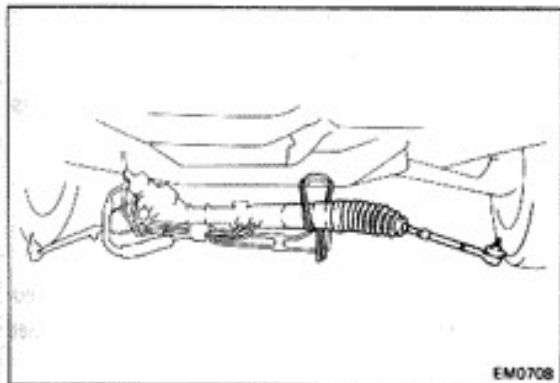
12. DISCONNECT SPEEDOMETER CABLE**13. REMOVE EXHAUST PIPE BRACKET AND CONVERTER COVER BOTH STIFFENER PLATES FROM TRANSMISSION HOUSING AND CYLINDER BLOCK****14. REMOVE POWER STEERING GEAR HOUSING**

- (a) Remove the sliding yoke from gear housing.
- (b) Disconnect both tie rod ends with SST. SST 09611-22012
- (c) Remove the fluid line clamps.
- (d) Remove the four bolts and remove the two brackets and rubber insulator.
- (e) Remove the gear housing from the crossmember and suspend it with strings.

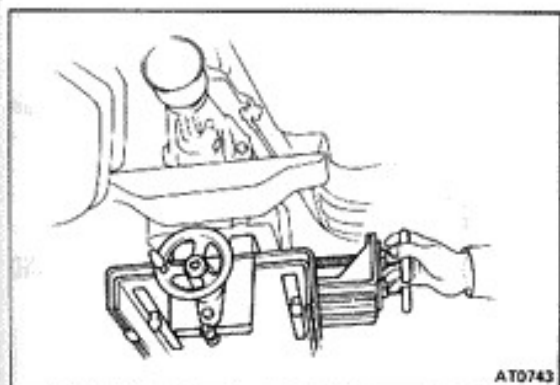
**15. JACK UP TRANSMISSION SLIGHTLY**

If a transmission jack is not available, be sure to put a wooden block between the jack and the transmission pan to prevent damage.

Raise the transmission enough to remove the weight from the rear support member.

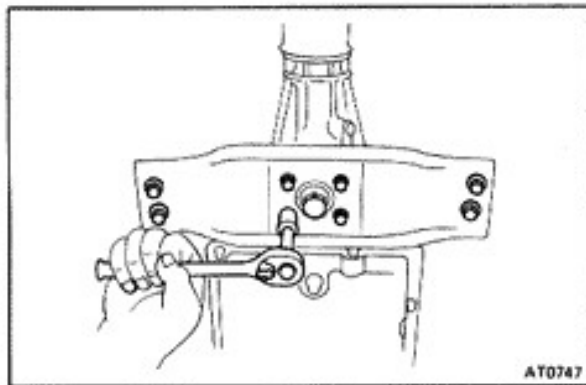
**16. REMOVE REAR SUPPORT MEMBER**

- (a) Remove the ground cable.
- (b) Install a wooden block between cowl panel and cylinder head rear end to prevent damage to the heater hose.
- (c) Remove the eight bolts, and remove the rear support member.

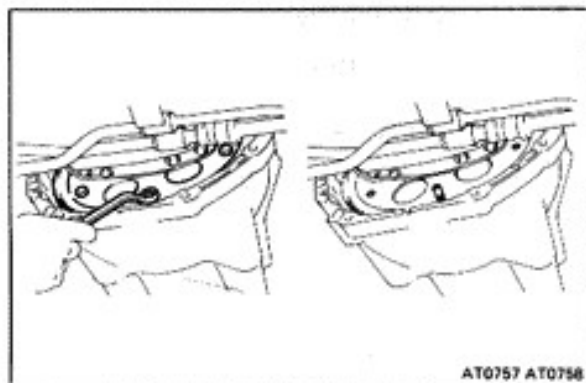
17. REMOVE ENGINE UNDER COVER**18. REMOVE SIX TORQUE CONVERTER MOUNTING BOLTS**

- Turn the crankshaft to gain access to each bolt.
Remove the six bolts.

19. INSTALL GUIDE PIN IN TORQUE CONVERTER

- Install the guide pin in one of the torque converter bolt holes.

If necessary, a guide pin can be made by cutting off the head of a bolt.

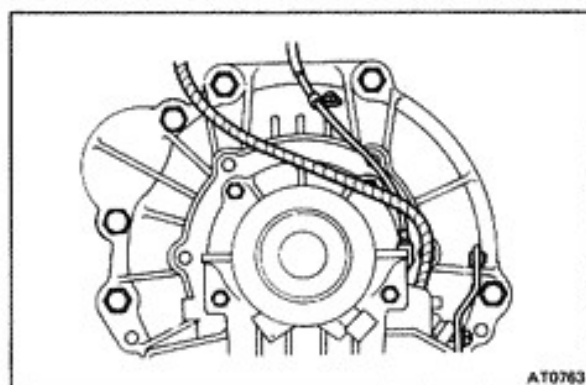
**20. REMOVE TRANSMISSION HOUSING MOUNTING BOLTS**

- (a) Remove the starter.
- (b) Remove the transmission housing mounting bolts.

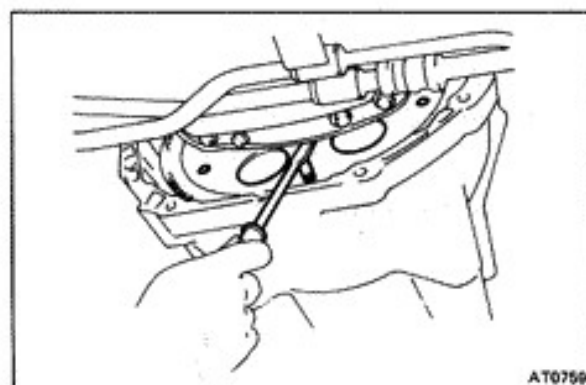
**21. PRY ON END OF GUIDE PIN TO BEGIN MOVING TRANSMISSION WITH CONVERTER TOWARD REAR**

The guide pin helps keep the converter with the transmission.

22. REMOVE TRANSMISSION ASSEMBLY

Draw out the transmission down and toward the rear.

CAUTION: Be careful not to snag the throttle cable or neutral start switch cable. Keep the oil pan positioned downward.

**23. PLACE PAN UNDER CONVERTER HOUSING, AND REMOVE CONVERTER**

Pull the converter straight off, and allow the fluid to drain into the pan.

24. REMOVE FILLER TUBE**25. REMOVE REAR TRANSMISSION MOUNT WITH GROUND STRAP**

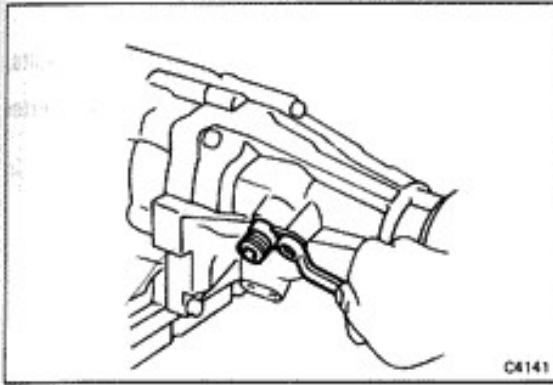
DISASSEMBLY OF TRANSMISSION**SEPARATE BASIC SUBASSEMBLY****1. REMOVE SPEEDOMETER DRIVEN GEAR****2. REMOVE SPEED SENSOR**

- (a) Disconnect the wiring connector.
- (b) Remove the speed sensor.

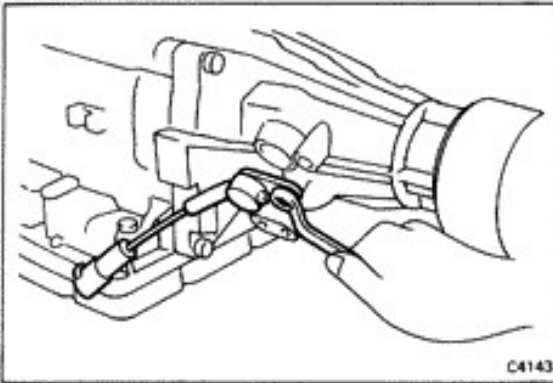
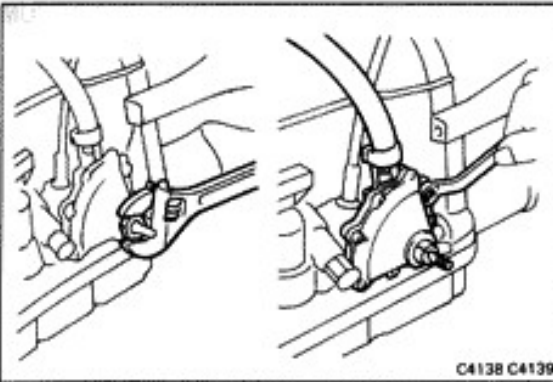
**3. REMOVE SHIFT HANDLE****4. REMOVE NEUTRAL START SWITCH****5. REMOVE OIL PUMP**

- (a) Remove the seven bolts.
- (b) Position SST on the shaft in back of the spline.
SST 09610-20012

CAUTION: Do not damage the shaft bushing surface. Turn the end bolt of SST to free the pump.

- (c) Grasp the front pump stator shaft and pull the pump from the case.

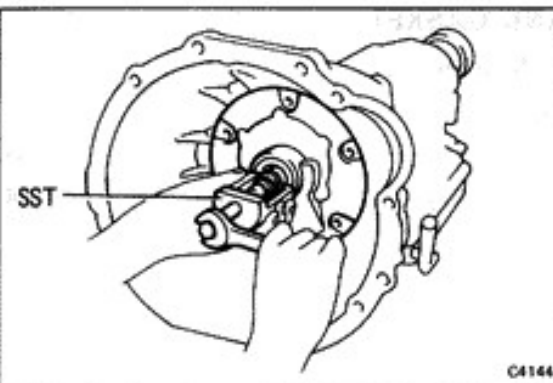
**6. WATCH FOR BEARING BEHIND OIL PUMP**

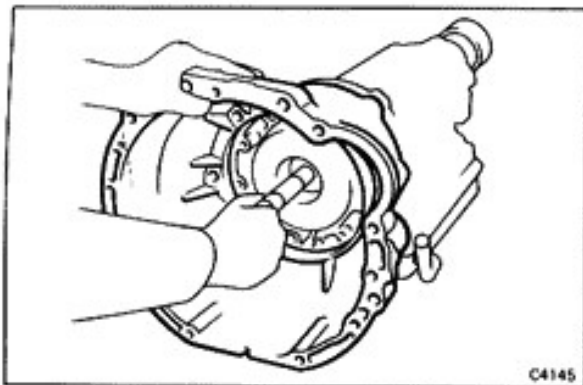

7. REMOVE CONVERTER HOUSING

- (a) Remove the two 12-mm bolts and four 10-mm bolts.
- (b) Hold the input shaft while removing the converter housing.

8. REMOVE EXTENSION HOUSING AND GASKET

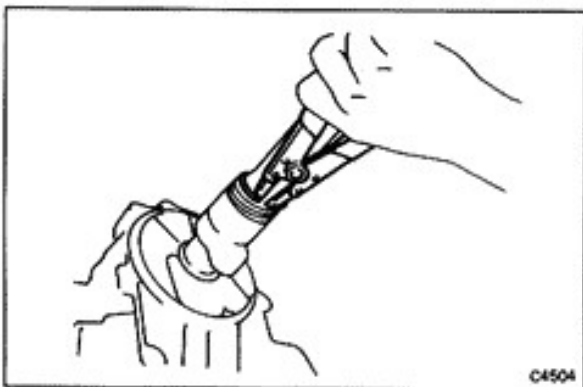

9. REMOVE SPEEDOMETER DRIVE GEAR

- (a) Remove the snap ring.
- (b) Remove the drive gear and the steel ball.

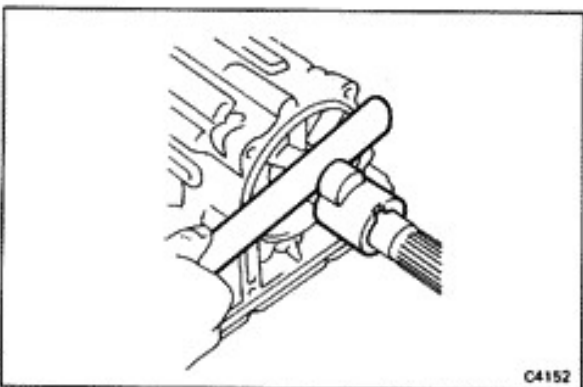

10. REMOVE SENSOR ROTOR, KEY AND SNAP RING FROM OUTPUT SHAFT

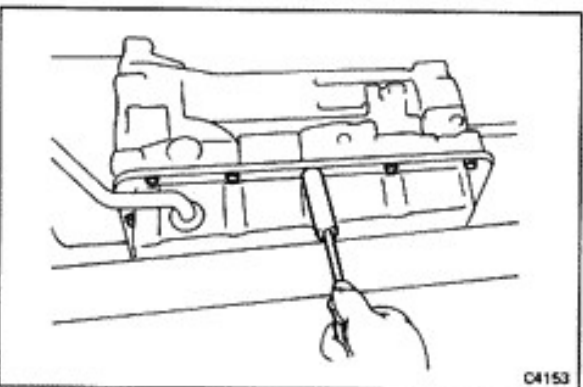

11. REMOVE PAN AND GASKET

- (a) Remove the fourteen bolts.
- (b) Remove the pan by lifting the transmission case.

NOTE: Do not turn the transmission over as this will contaminate the valve body with foreign materials in the bottom of the pan.

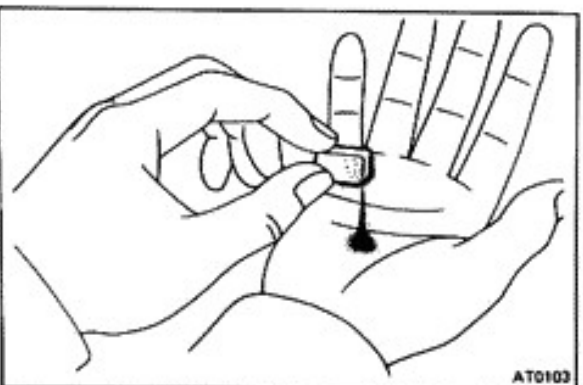

12. EXAMINE PARTICLES IN PAN

Remove the magnet and use it to collect any steel chips. Look carefully at the chips and particles in the pan and on the magnet to anticipate what type of wear you will find in the transmission:

Steel (magnetic) = bearing, gear and clutch plate wear.

Brass (nonmagnetic) = bushing wear.

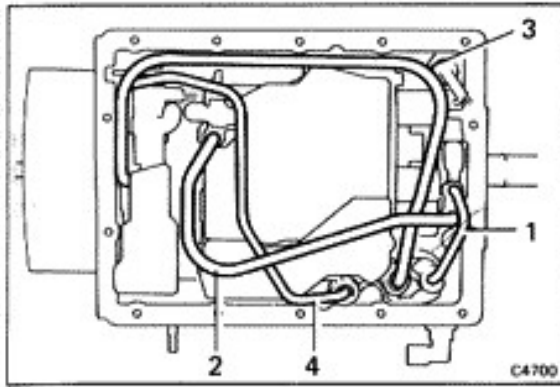

13. TURN TRANSMISSION OVER AND REMOVE TUBES

Pry up both tube ends with a large screwdriver and remove the four tubes.

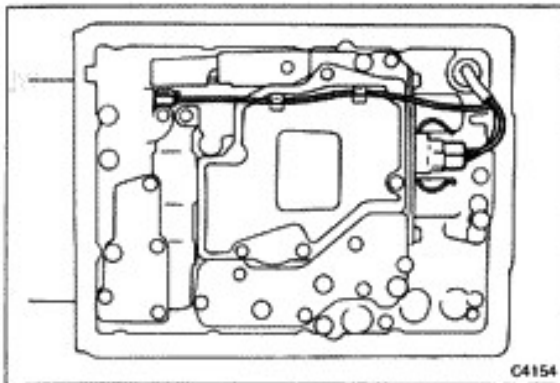

14. REMOVE SOLENOID WIRING

- (a) Disconnect connector from the No. 1 and 2 solenoid and the No. 3 solenoid.
- (b) Remove the grommet from the transmission case.
- (c) Pull the wiring out of the transmission case.

15. REMOVE STRAINER

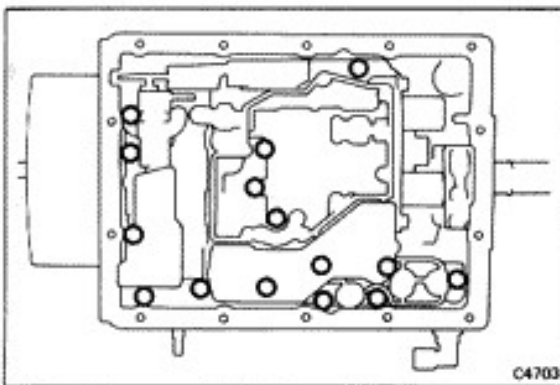

16. REMOVE VALVE BODY

- (a) Remove the fifteen bolts.

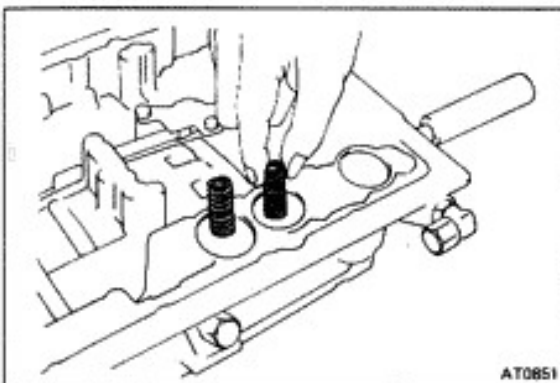

- (b) Remove the B₂ and C₂ accumulator piston springs.
- (c) Disconnect the throttle cable from the cam and remove the valve body.

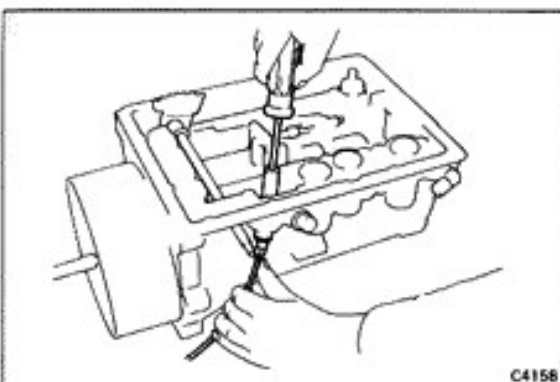

17. REMOVE THROTTLE CABLE AND RETAINER

Using a 10-mm socket, push the plastic throttle cable retainer out of the transmission case.

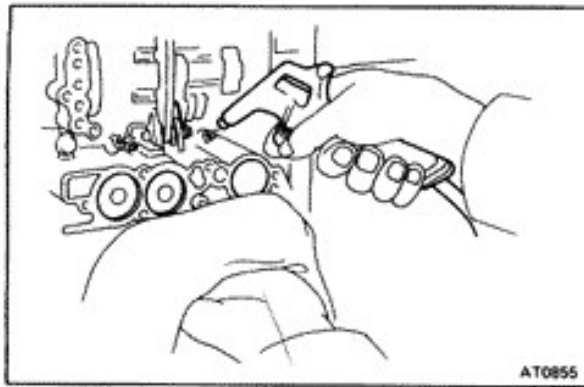

18. COVER PISTON WITH A RAG AND REMOVE ACCUMULATOR PISTONS AND SPRINGS

WARNING: Keep face away to avoid injury.

Position a rag to catch each piston. Using low-pressure compressed air (1 kg/cm², 14 psi or 98 kPa, max.), pop each piston into the rag. Force air into the holes shown, and remove the pistons and springs.

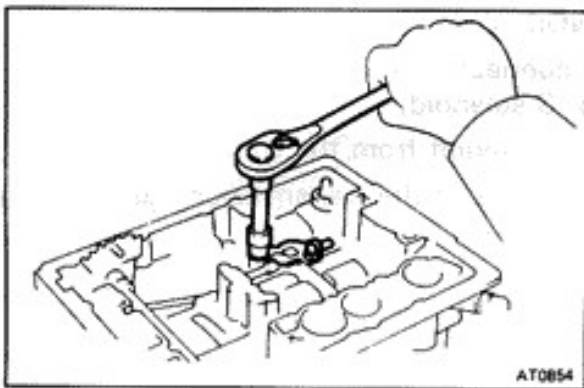

19. REMOVE PARKING LOCK ROD

20. REMOVE SPRING, PIVOT PIN AND PARKING LOCK PAWL

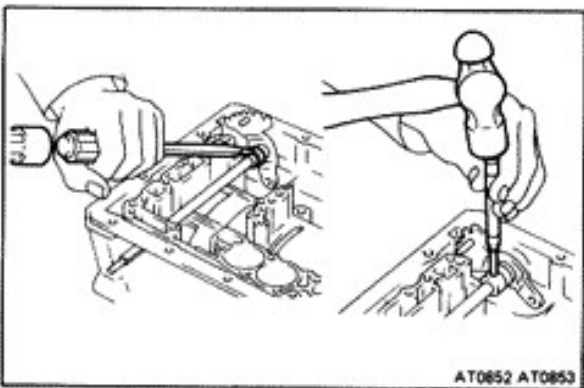

21. IF NECESSARY, REMOVE MANUAL LEVER SHAFT

- Using a hammer and screwdriver, pry and shift the collar.
- Using a hammer and punch, drive out the pin.
- Slide the shaft out case and remove the detent plate.

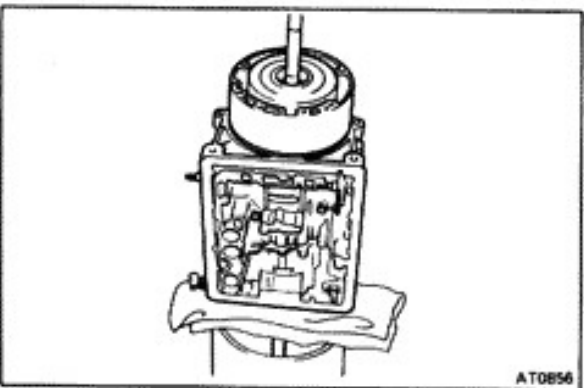

22. PLACE TRANSMISSION CASE ON CYLINDER

Place the transmission on a cylindrical stand for more efficient work.

CAUTION: Place shop rags between the case and stand to avoid damaging the case.

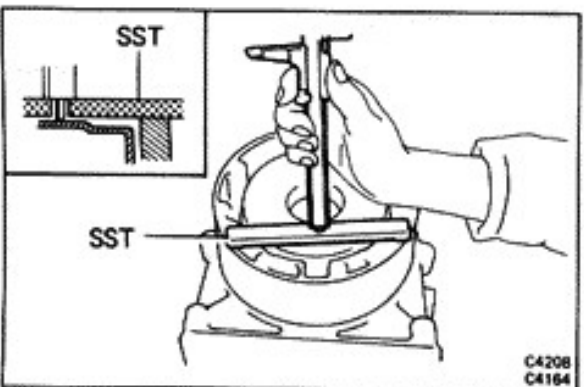

23. MEASURE DISTANCE BETWEEN TOP OF CASE AND CLUTCH DRUM

Set SST on the case as shown in the figure.

SST 09350-20013 (09370-12010)

Make a note of the finding for reassembly.

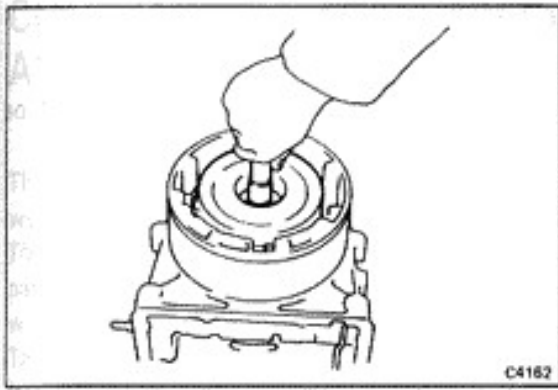
**24. REMOVE OVERDRIVE CLUTCH**

Grasp the shaft and pull out the overdrive clutch assembly. Watch for the bearings and races on both sides of the assembly.

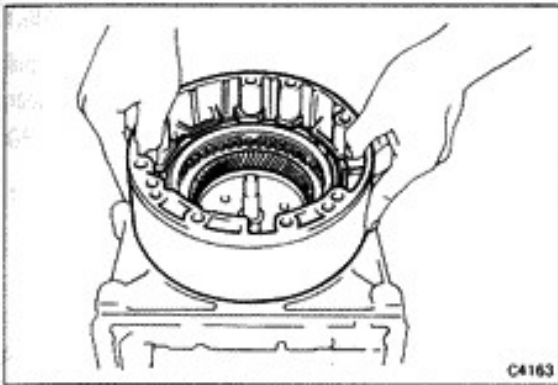
**25. REMOVE OVERDRIVE CASE AND BRAKE**

Hold both sides of the overdrive case and pull it out from the transmission case. Watch for the bearings and races on both sides of the assembly.

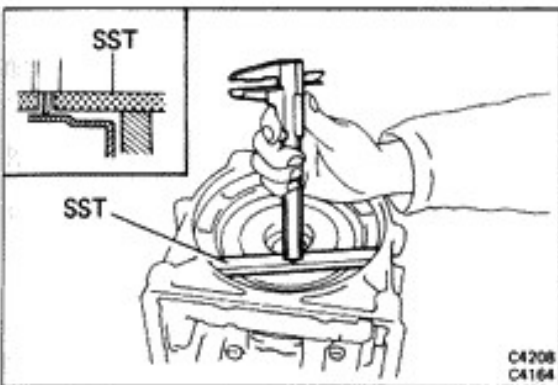
**26. MEASURE DISTANCE BETWEEN TOP OF CASE AND CLUTCH DRUM**

Set SST on the case as shown in the figure.

SST 09350-20013 (09370-12010)

Make a note of the finding for reassembly.

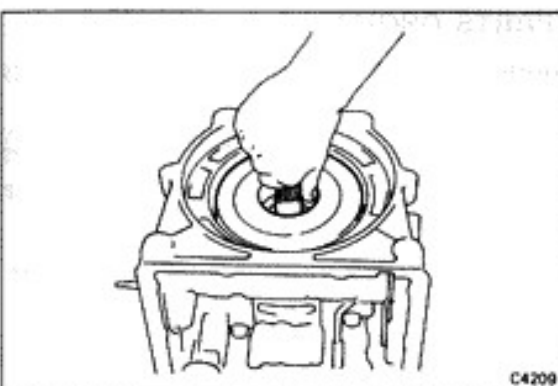
**27. REMOVE FRONT CLUTCH AND BEARINGS**

Grasp the shaft and pull out the front clutch assembly.

Watch for the bearings and races on both sides of the assembly.

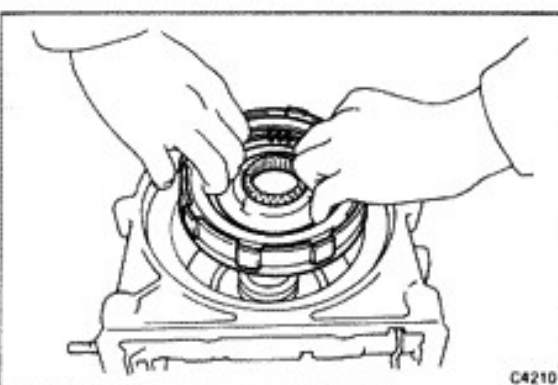
**28. REMOVE REAR CLUTCH**

Grasp the clutch hub and pull it out from the case.

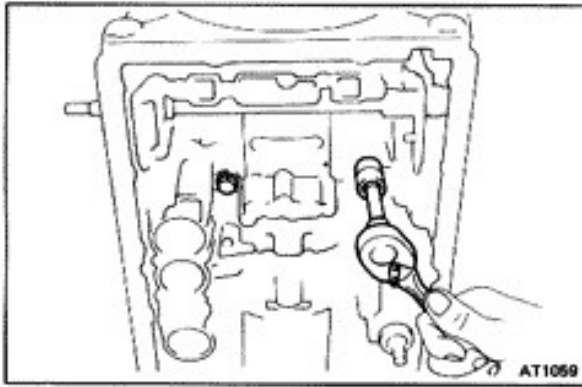
**29. REMOVE CENTER SUPPORT BOLTS**

Remove the two center support bolts.

NOTE: After removing one bolt, the other one will be loose.

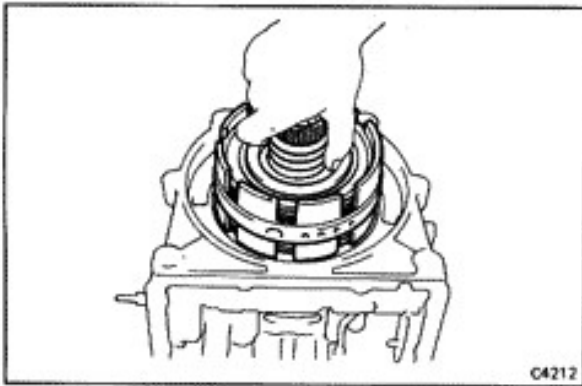
**30. REMOVE CENTER SUPPORT AND SUN GEAR ASSEMBLY**

From the case front opening, grasp the assembly and pull it out. Watch for the bearing race on the end of the sun gear.

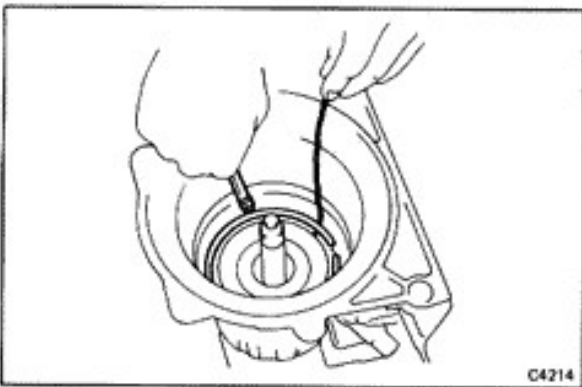
**31. REMOVE REACTION PLATE RETAINING RING**

Using a long screwdriver, compress the snap ring and lift it above the groove with a wire hook.

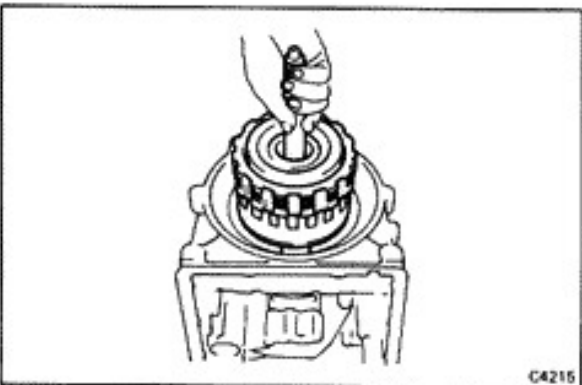
**32. REMOVE REAR PARTS GROUP**

Grasp the intermediate shaft and pull out the rear parts group.

If the brake apply tube and rear thrust bearing and races do not come out with the assembly, remove them from the case.

Watch for the bearing and race in the transmission case.

33. BASIC DISASSEMBLY IS COMPLETE

The transmission is now in basic component subassemblies. Next, disassemble, clean, inspect, repair and assemble each of these component groups.

COMPONENT GROUP DISASSEMBLY, INSPECTION AND ASSEMBLY

The instructions here are organized so that you work on only one component group at a time.

This will help avoid confusion of similar-looking parts from different subassemblies being on your workbench at the same time.

The component groups are inspected and repaired from the converter housing side.

As much as possible, complete the inspection, repair, assembly before proceeding to the next component group. If a component group cannot be assembled because parts are being ordered, be sure to keep all parts of that group in a separate container while proceeding with disassembly, inspection, repair and assembly of other component groups.

GENERAL CLEANING

1. All disassembled parts should be washed clean and the fluid passages and holes blown through with compressed air to make sure that they are not clogged.
2. Cleaning solvent used should be the recommended ATF or kerosene.
3. When using compressed air to dry parts, keep face away to avoid spraying solvent in your face.

PARTS ARRANGEMENT

1. After cleaning, the parts should be arranged in proper order to allow performing the inspection, repairs, and reassembly with efficiency.
2. New brakes and clutches that are to be used for replacement must be soaked in transmission fluid for at least two hours before assembly.
3. When disassembling a valve body, be sure to keep each valve together with the corresponding spring.

GENERAL ASSEMBLY

1. All oil seal rings, clutch discs, clutch plates, rotating parts, and sliding surfaces should be coated with transmission fluid prior to reassembly.
2. If a worn bushing is to be replaced, the replacement must be made with the subassembly containing that bushing.
3. All gaskets and rubber O-rings should be replaced.
4. Check thrust bearings and races for wear or damage. Replace if necessary.
5. Make sure that the ends of a snap ring are not aligned with one of the cutouts and are installed in the groove correctly.
6. Use petroleum jelly to keep parts in place.

Oil Pump

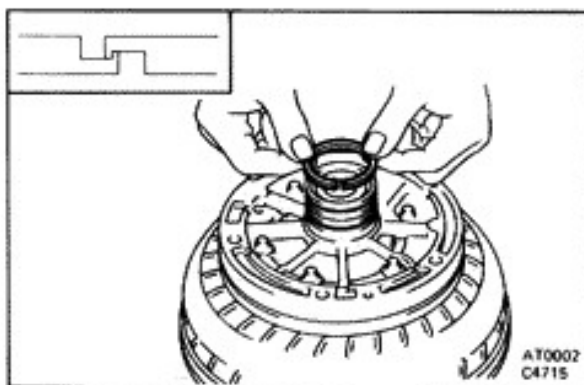
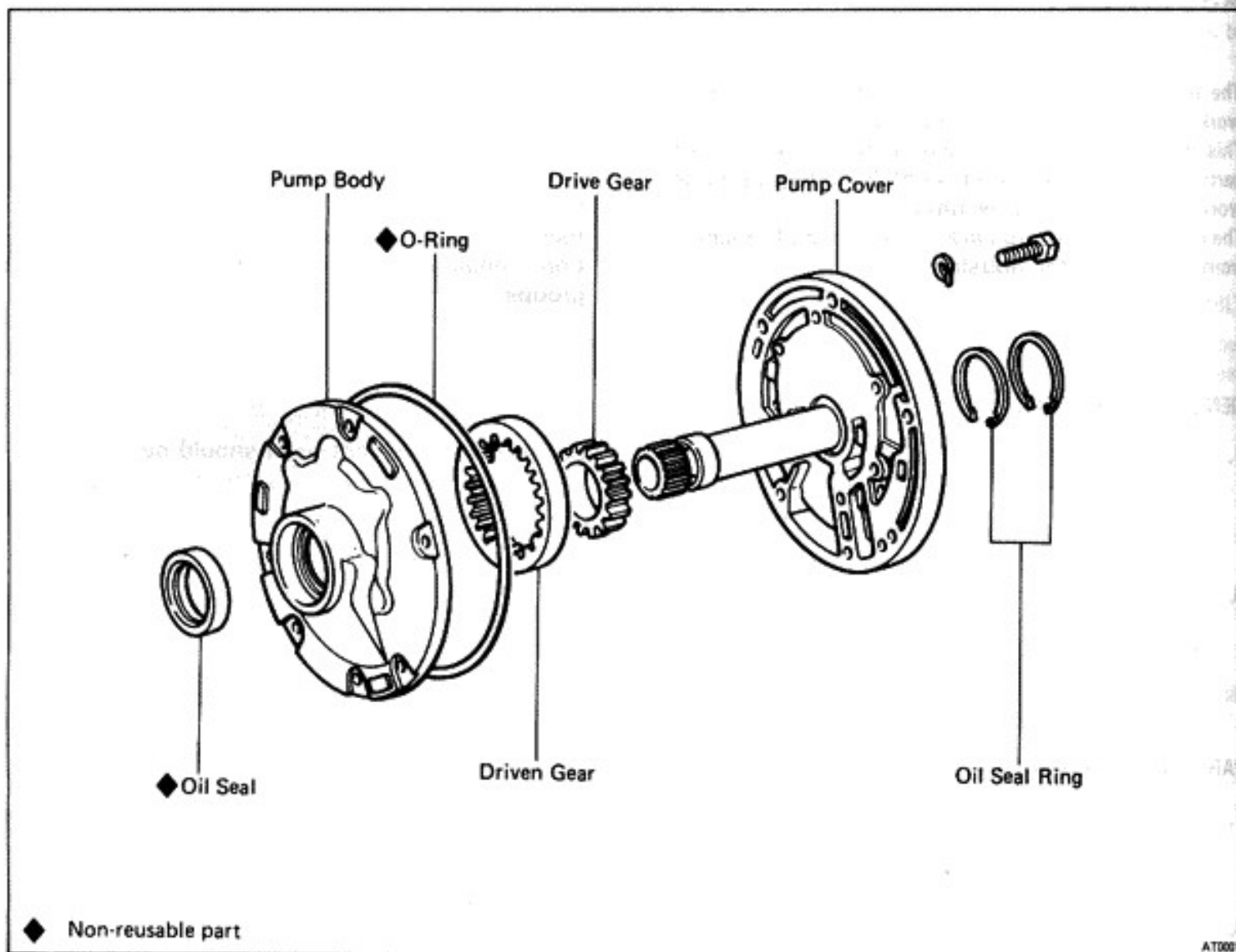

DISASSEMBLY OF OIL PUMP

1. USE TORQUE CONVERTER AS A WORK STAND
2. REMOVE TWO OIL SEAL RINGS FROM PUMP COVER

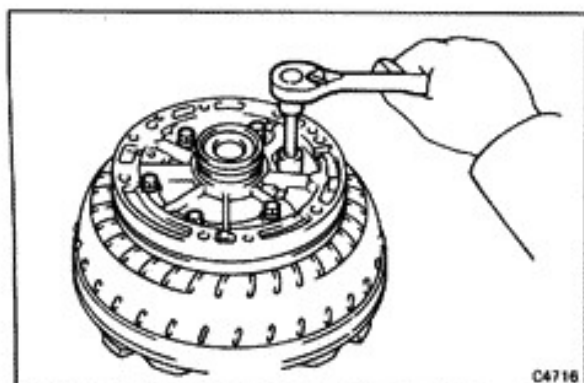

3. REMOVE PUMP COVER
4. REMOVE O-RING FROM PUMP
5. LIFT PUMP OFF CONVERTER AND REMOVE OIL PUMP DRIVE GEAR AND DRIVEN GEAR

Identify the top and bottom and keep in assembly order.

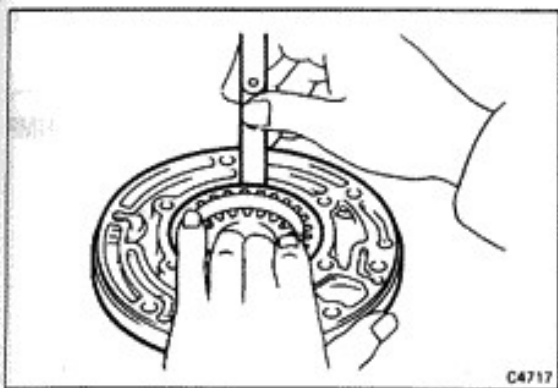

INSPECTION OF OIL PUMP

1. CHECK BODY CLEARANCE OF DRIVEN GEAR

Push the driven gear to one side of the body. Using a feeler gauge, measure the clearance.

Standard body clearance: 0.07 – 0.15 mm
(0.0028 – 0.0059 in.)

Maximum body clearance: 0.3 mm (0.012 in.)

If the body clearance is greater than the maximum, replace the drive gear, driven gear or pump body.

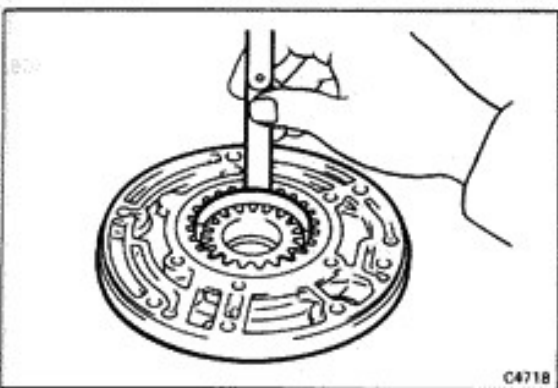

2. CHECK TIP CLEARANCE OF BOTH GEARS

Measure between the gear teeth and the crescent-shaped part of the pump body.

Standard tip clearance: 0.11 – 0.14 mm
(0.0043 – 0.0055 in.)

Maximum tip clearance: 0.3 mm (0.012 in.)

If the tip clearance is greater than the maximum, replace the drive gear, driven gear or pump body.

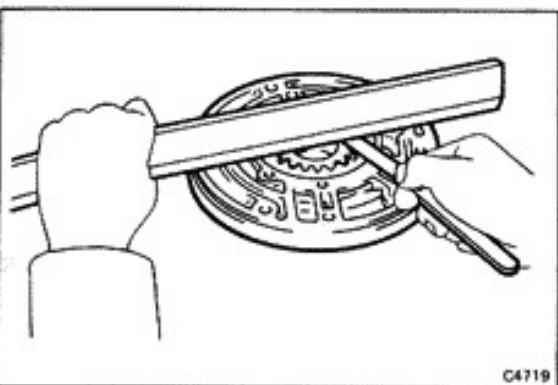

3. CHECK SIDE CLEARANCE OF BOTH GEARS

Using a steel straightedge and a feeler gauge, measure the side clearance of both gears.

Standard side clearance: 0.02 – 0.05 mm
(0.0008 – 0.0020 in.)

Maximum side clearance: 0.1 mm (0.004 in.)

If the side clearance is greater than the maximum, replace the drive gear, driven gear or pump body.

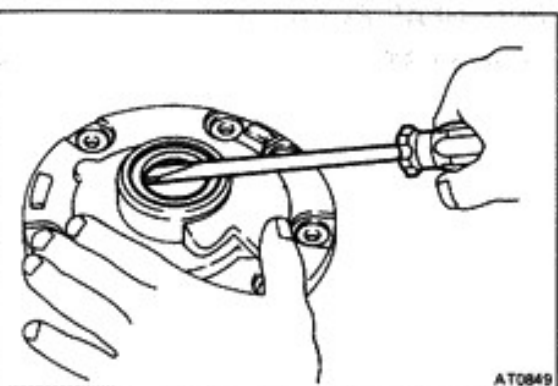

4. INSPECT FRONT OIL SEAL

Check for wear, damage or cracks.

5. IF NECESSARY, REPLACE FRONT OIL SEAL

(a) Pry off the oil seal with a screwdriver.

(b) Using SST and a hammer, install a new oil seal.

The seal end should be flush with the outer edge of the pump body.

SST 09350-20013 (09388-20010)

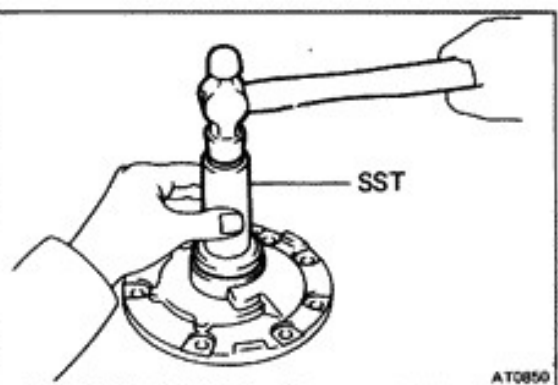

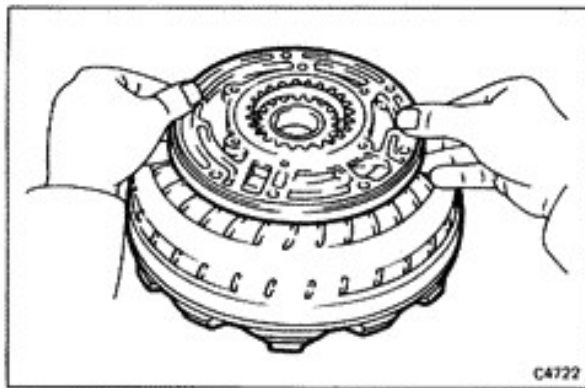

ASSEMBLY OF OIL PUMP

(See page AT-52)

- 1. INSTALL DRIVEN GEAR AND DRIVE GEAR AND SET PUMP BODY ON TORQUE CONVERTER**

Make sure the top of the gears is facing upward.

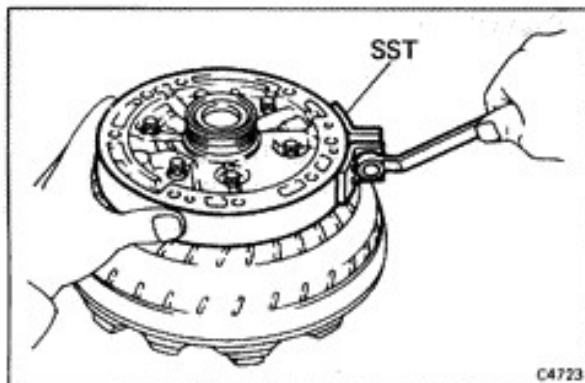

- 2. LOOSELY INSTALL PUMP COVER**

Align the bolt holes and drop the pump cover into place. Install the six bolts with wave washers finger tight.

- 3. ALIGN PUMP AND PUMP COVER**

Install the SST around the pump and cover. Tighten SST to align the pump and cover.

SST 09350-20013 (09363-20010)

- 4. TIGHTEN SIX PUMP COVER BOLTS**

Torque: 75 kg-cm (65 in.-lb, 7.4 N·m)

- 5. INSTALL TWO OIL SEAL RINGS ON PUMP COVER**

Spread the rings apart and slide them into the groove. Hook both ends by hand.

Wipe off excess petroleum jelly.

- 6. INSTALL NEW O-RING ON PUMP COVER**

Make sure a new O-ring is not twisted and is fully seated in the groove.

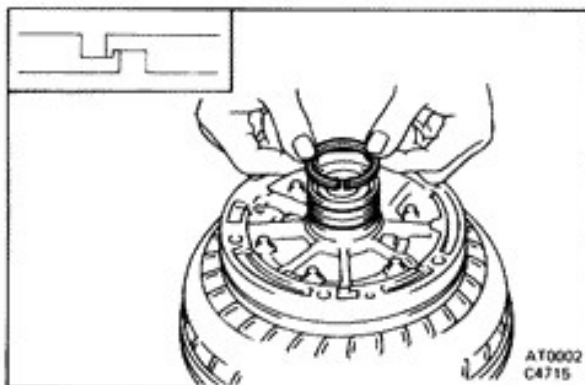

- 7. CHECK PUMP DRIVE GEAR ROTATION**

Turn the drive gear with SST and make sure that it rotates smoothly.

SST 09350-20013 (09397-22020)

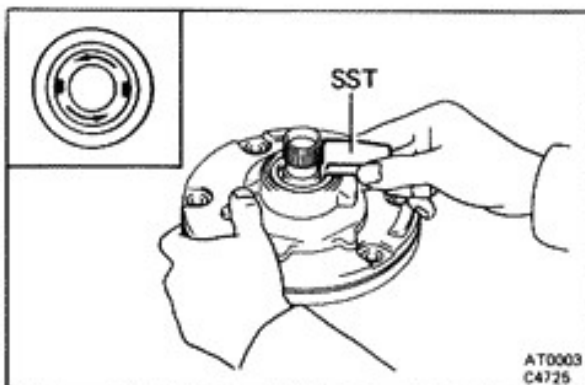

Overdrive Input Shaft and Clutch

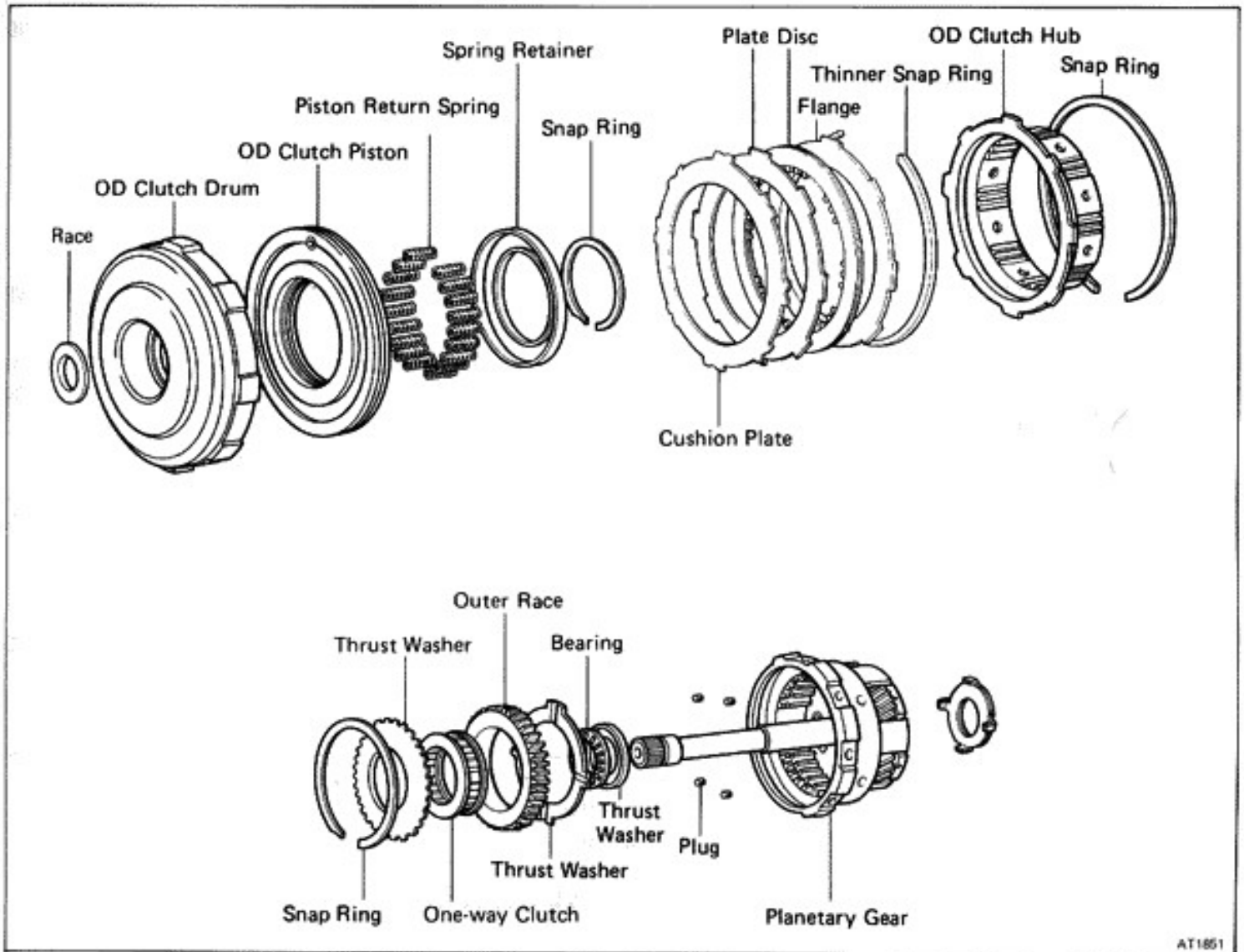

AT1851

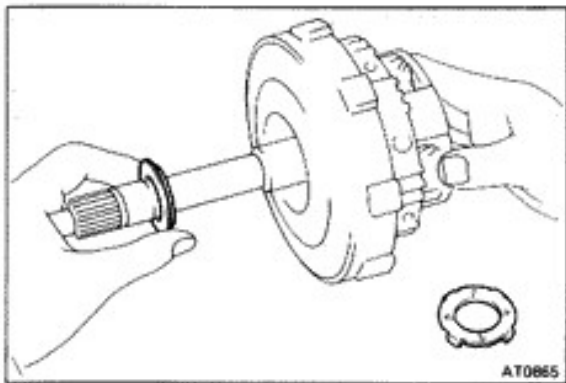

AT0865

DISASSEMBLY OF OVERDRIVE INPUT SHAFT AND CLUTCH

1. REMOVE THRUST BEARINGS AND RACES FROM OVERDRIVE INPUT SHAFT

- (a) Slide off the thrust bearing and race from the clutch side by hand. Note the position of the races.
- (b) Using a screwdriver, pry off the thrust washer from the planetary gear side.

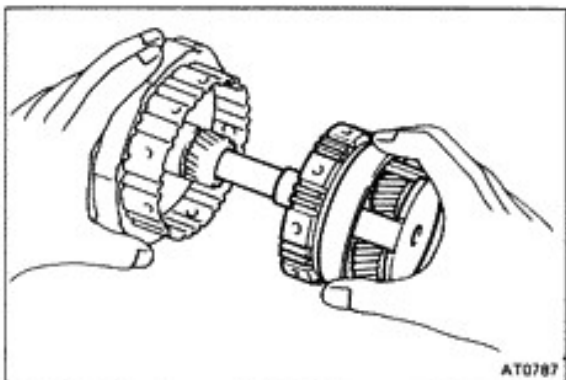

AT0787

2. PULL OVERDRIVE CLUTCH ASSEMBLY FROM INPUT SHAFT

CAUTION: Be careful that the thrust bearing and race do not fall out.

3. REMOVE THRUST BEARING AND RACE

Note the position of the race.

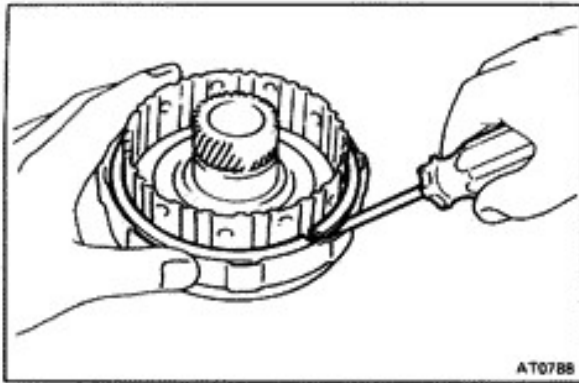

4. REMOVE SNAP RING AND HUB FROM OVERDRIVE CLUTCH ASSEMBLY

5. REMOVE THINNER SNAP RING, FLANGE, DISC AND PLATE

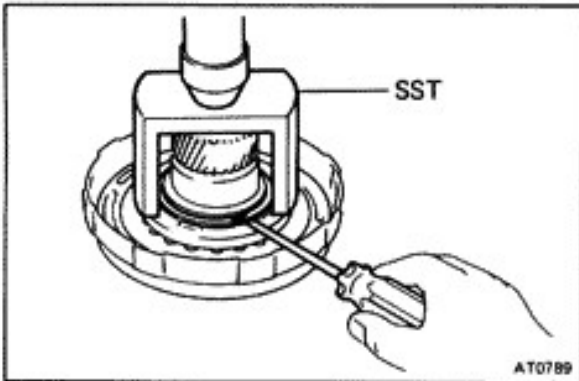

6. COMPRESS PISTON RETURN SPRINGS AND REMOVE SNAP RING

Place SST on the spring retainer and compress the springs with a shop press. Using a screwdriver, remove the snap ring.

SST 09350-20013 (09369-20040)

7. REMOVE SPRING RETAINER AND EIGHTEEN SPRINGS

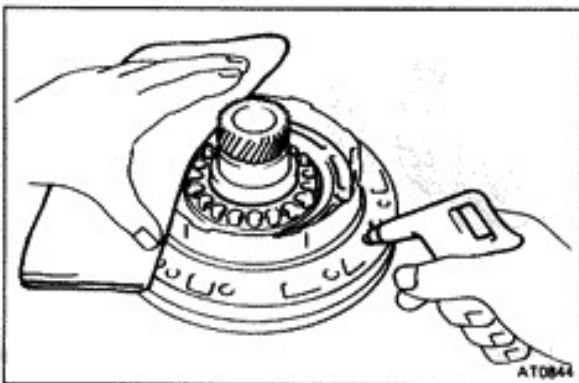

8. ASSEMBLE OVERDRIVE CLUTCH ON OIL PUMP AND BLOW OUT PISTON

- (a) Slide the overdrive clutch onto the oil pump.
- (b) Apply compressed air to the oil pump to remove the piston. (If the piston does not come out completely, use needle-nose pliers to remove it.)
- (c) Remove the overdrive clutch from the oil pump.

9. REMOVE CLUTCH PISTON O-RINGS

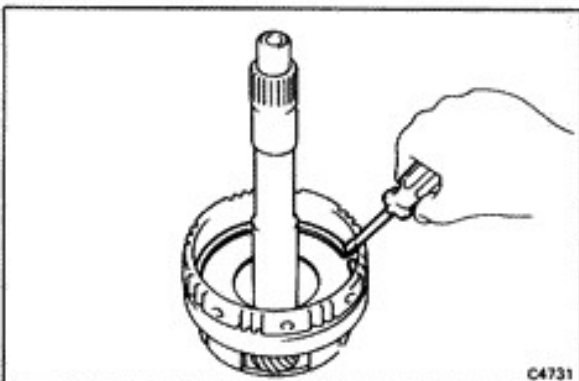

10. REMOVE SNAP RING FROM OVERDRIVE PLANETARY GEAR ASSEMBLY

11. REMOVE THRUST WASHERS AND ONE-WAY CLUTCH FROM PLANETARY GEAR ASSEMBLY

CAUTION: Be careful not to lose the four plugs.

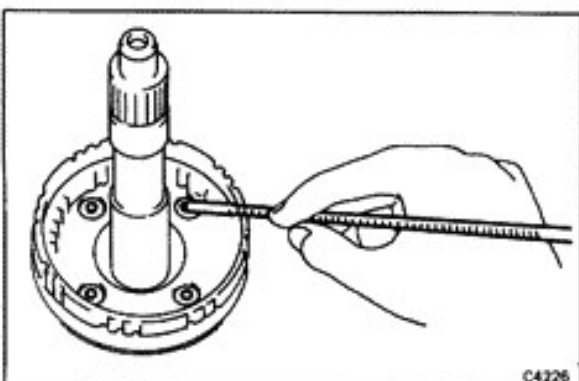

12. REMOVE FOUR PLUGS WITH MAGNETIC FINGER

CAUTION: Keep the four plugs together to prevent losing them.

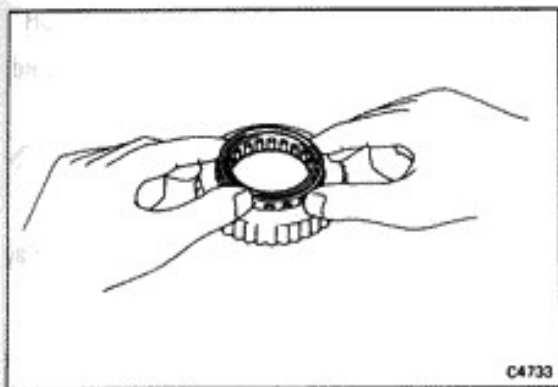

13. REMOVE ONE-WAY CLUTCH FROM OUTER RACE

Note the direction of the one-way clutch.

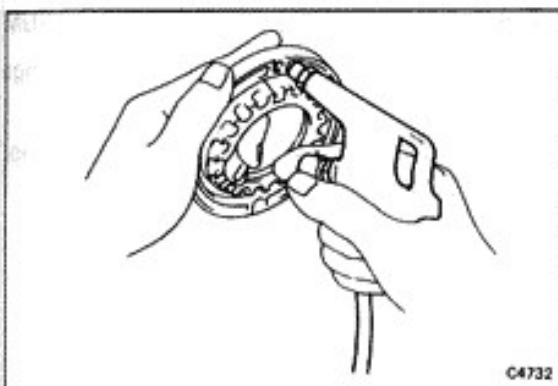

INSPECTION OF OVERDRIVE INPUT SHAFT AND CLUTCH

1. INSPECT CLUTCH PISTON

- (a) Check that check ball is free by shaking the piston.
- (b) Check that the valve does not leak by applying low-pressure compressed air.

2. INSPECT DISC, PLATE AND FLANGE

Check that the sliding surface of disc is not worn or burnt. If the disc is worn or burnt, replace disc.

Then check that the sliding surfaces of plate and flange are not worn or burnt.

If necessary, replace them.

NOTE: Do not allow the discs to dry out.

Prepare new discs by soaking them at least two hours in ATF.

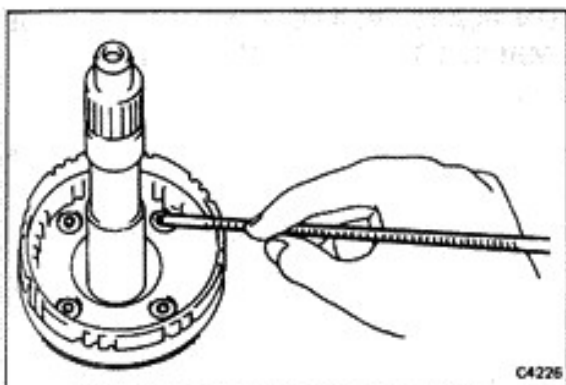

ASSEMBLY OF OVERDRIVE INPUT SHAFT AND CLUTCH

(See page AT-55)

1. INSTALL FOUR PLUGS

2. INSTALL THRUST WASHER AND BEARING

- (a) Coat parts with petroleum jelly to hold them in place.
- (b) Slide bearing and then thrust washer facing lip outward.

3. ASSEMBLE ONE-WAY CLUTCH

- (a) Install the one-way clutch into the outer race.
- (b) Install a retainer on both sides of the one-way clutch.

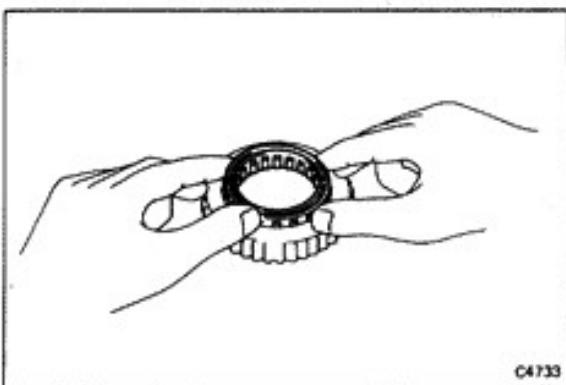

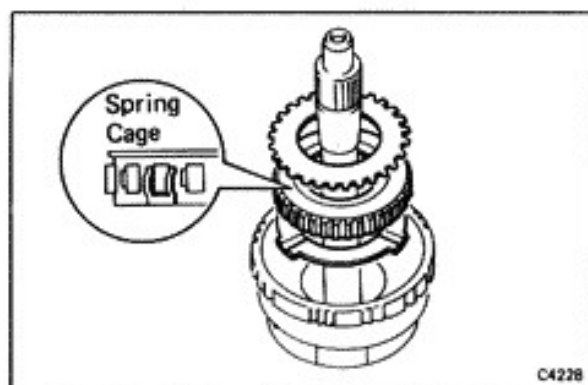

4. **INSTALL THRUST WASHER AND ONE-WAY CLUTCH**
 - (a) Install the thrust washer, facing the grooves upward.
 - (b) Install the one-way clutch in correct direction.
 - (c) Install the thrust washer.
 - (d) Install the snap ring.

NOTE: Be sure that the spring cage side of the one-way clutch faces toward the front of the transmission.

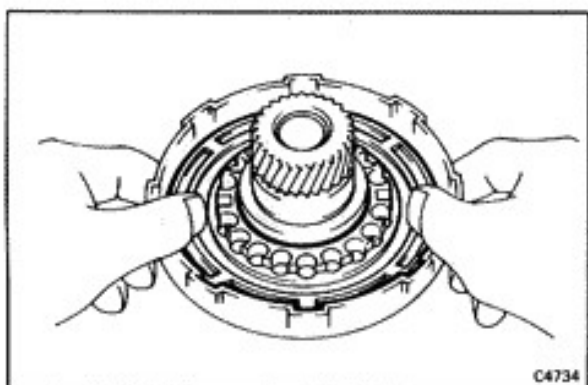

5. **INSTALL CLUTCH PISTON IN OVERDRIVE CLUTCH DRUM**
 - (a) Install new O-rings on the piston. Coat the O-rings with ATF.
 - (b) Press the piston into the drum with the cup side up, being careful not to damage the O-ring.

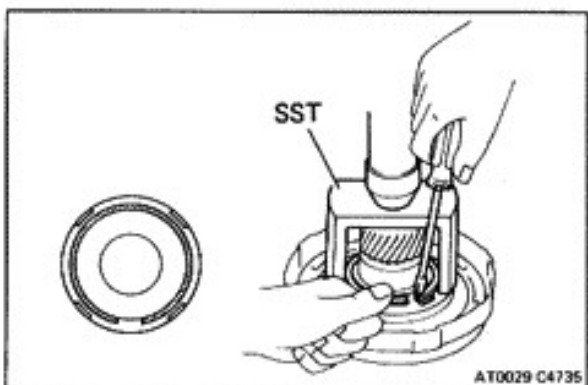

6. **INSTALL EIGHTEEN PISTON RETURN SPRINGS AND SET RETAINER AND SNAP RING IN PLACE**
7. **COMPRESS RETURN SPRINGS AND INSTALL SNAP RING IN GROOVE**

- (a) Place SST on the spring retainer, and compress the springs on a shop press.

SST 09350-20013 (09369-20040)

- (b) Install the snap ring with a screwdriver.

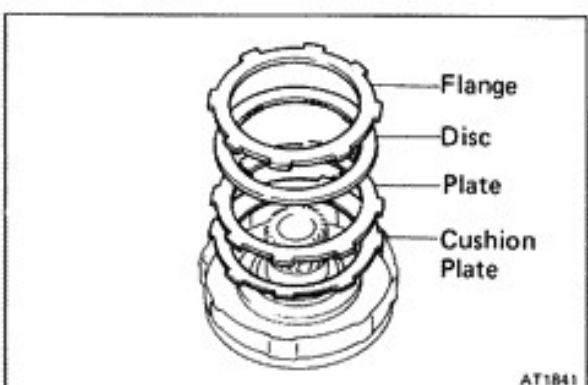

8. **INSTALL CUSHION PLATE, PLATE, DISC AND FLANGE WITHOUT ASSEMBLING THINNER SNAP RING**
 - (a) Do not assemble the thinner snap ring yet.
 - (b) Using low-pressure compressed air, blow all excess ATF from the disc.

CAUTION: High-pressure air will damage the disc.

Install in order: Cushion plate-plate-disc-flange (flat end down)

9. **CHECK PISTON STROKE OF OVERDRIVE CLUTCH**

- (a) Install the overdrive clutch hub and outer snap ring.
- (b) Install the front clutch drum onto the oil pump body. With a dial indicator, measure the stroke applying and releasing the compressed air (4 – 8 kg/cm², 57 – 114 psi or 392 – 785 kPa) as shown.

**Standard piston stroke: 1.77 – 2.58 mm
(0.0697 – 0.1016 in.)**

If the stroke exceeds limit, the clutch pack is probably worn. If the stroke is less than the limit, parts may be misassembled or there may be excess ATF on the discs.

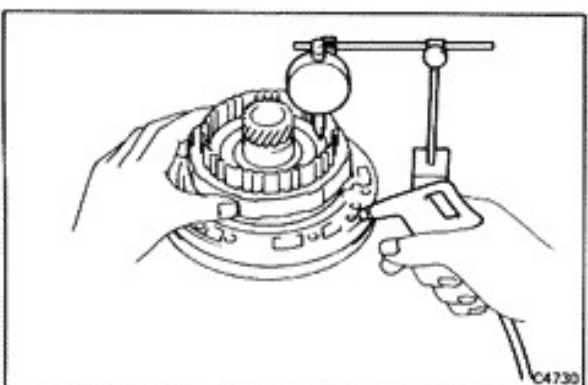

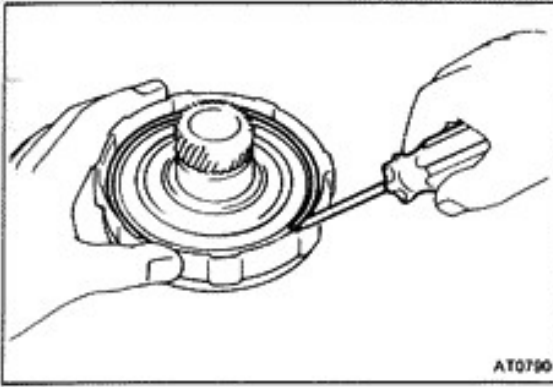

10. INSTALL THINNER SNAP RING IN OVERDRIVE CLUTCH DRUM

- (a) Remove the overdrive clutch outer snap ring and hub to allow installation of the thinner snap ring.
- (b) Compress and lower the snap ring into the groove by hand. Check that the ends of the snap ring are not aligned with one of the cutouts.

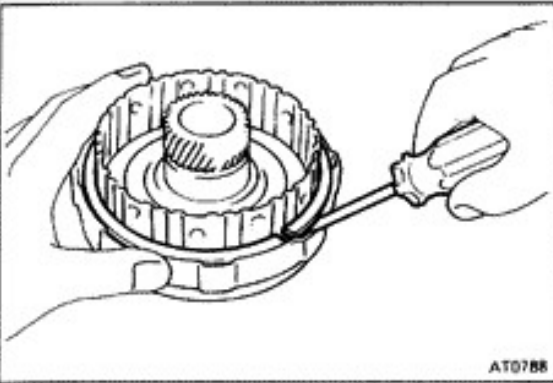

11. INSTALL HUB AND OUTER SNAP RING

Check that the ends of the snap ring are not aligned with one of the cutouts.

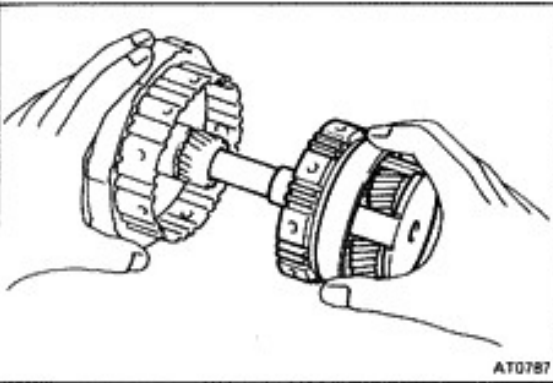

12. ASSEMBLE OVERDRIVE CLUTCH DRUM AND OVERDRIVE PLANETARY GEAR

Mesh the hub with the disc, twisting and jiggling the hub as required.

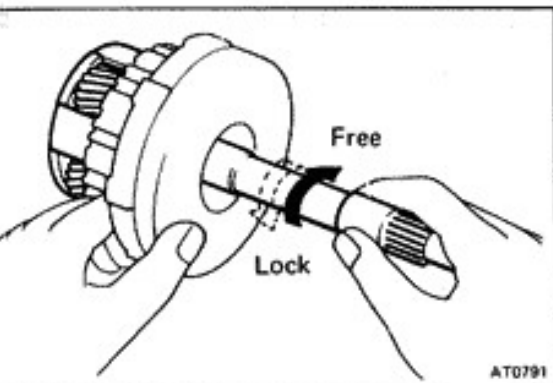

13. CHECK OPERATION OF ONE-WAY CLUTCH

Hold the clutch drum and turn the input shaft. The input shaft should turn freely clockwise and should lock counterclockwise.

14. KEEP THRUST WASHER, THRUST BEARINGS AND RACE TOGETHER

Overdrive Case and Brake

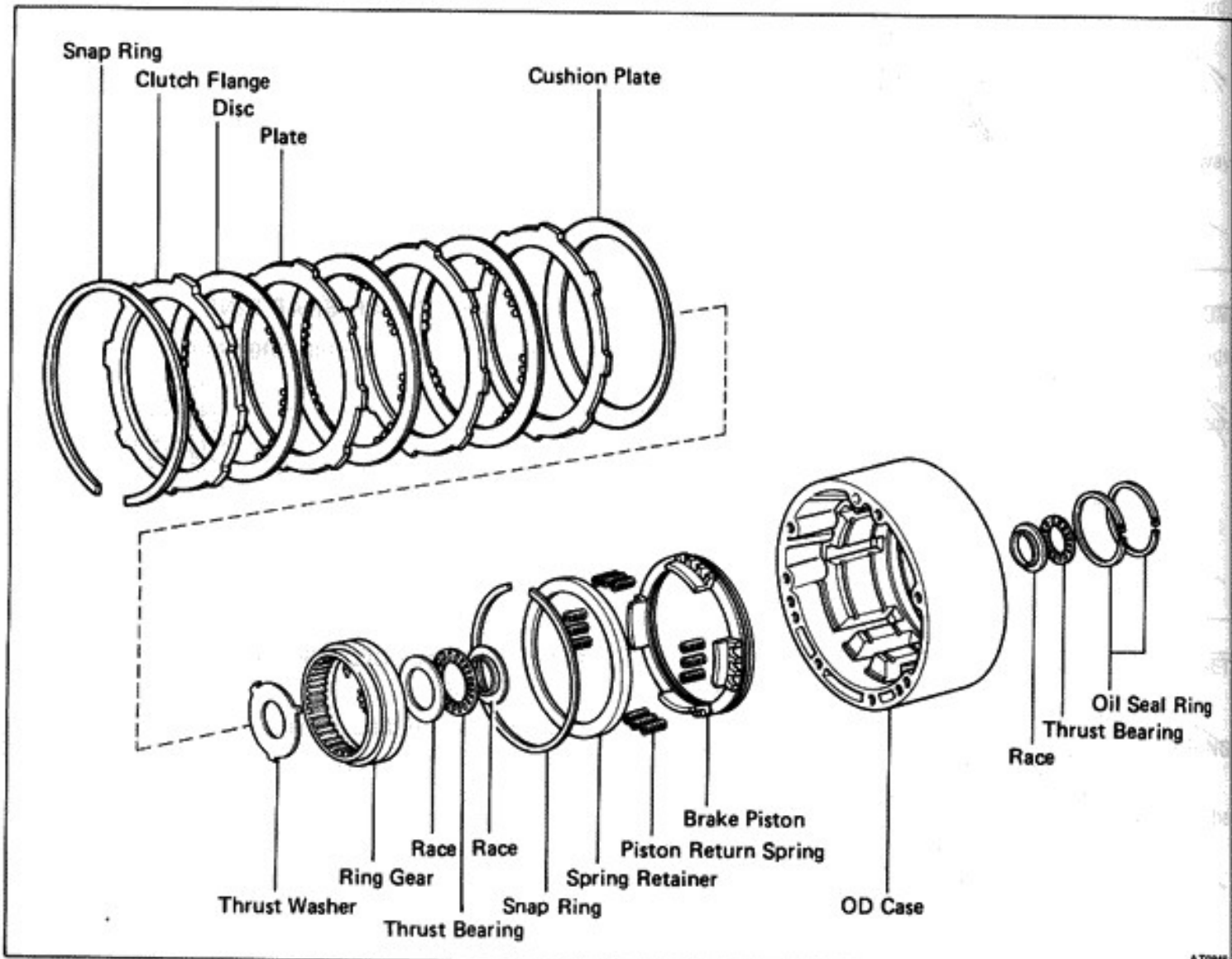

AT0845

DISASSEMBLY OF OVERDRIVE CASE AND BRAKE

1. REMOVE RACE FROM OVERDRIVE

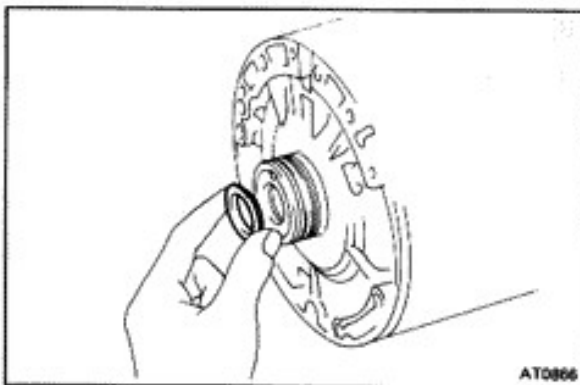

2. REMOVE OUTER SNAP RING FROM OVERDRIVE CASE
3. REMOVE CLUTCH FLANGE, DISCS PLATES AND CUSHION PLATE

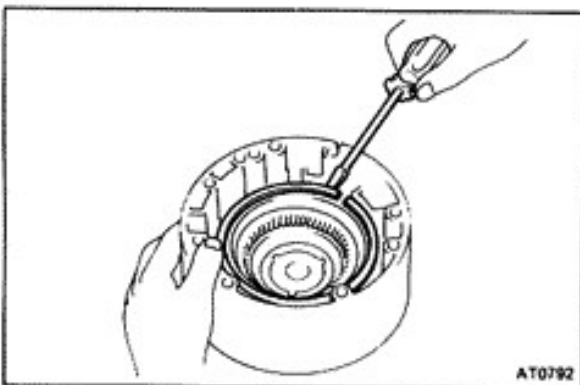

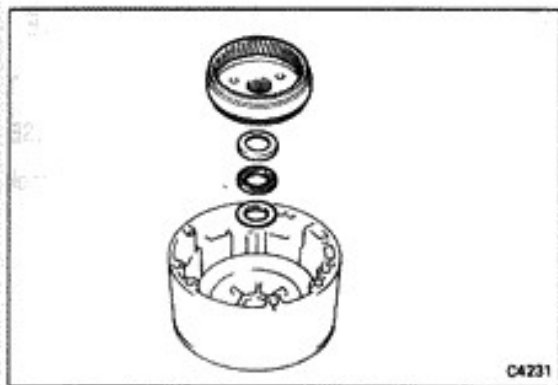

4. REMOVE RING GEAR AND THRUST WASHER
5. REMOVE THRUST BEARING AND RACES FROM OVERDRIVE CASE

Note the position of the races.

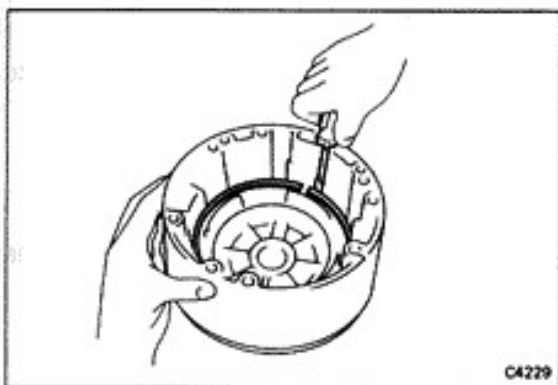

6. REMOVE SNAP RING, SPRING RETAINER AND RETURN SPRINGS

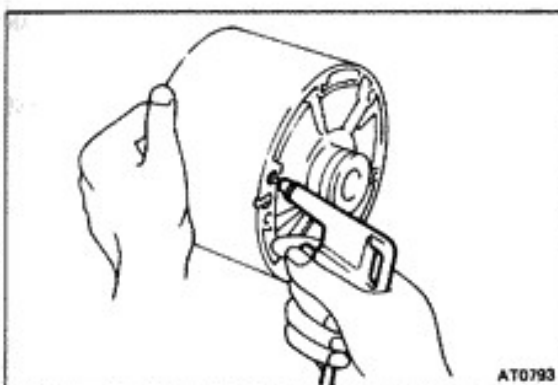

7. REMOVE BRAKE PISTON

Blow compressed air through the case hole indicated in the figure to pop out the brake piston.

If the piston does not pop out, lift it out with needle-nose pliers.

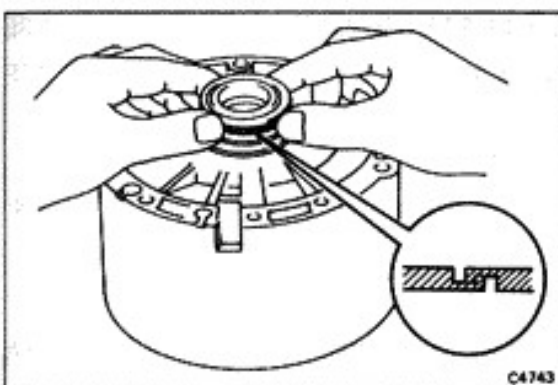

8. REMOVE TWO OIL SEAL RINGS FROM OVERDRIVE CASE
9. REMOVE O-RINGS FROM PISTON

INSPECTION OF OVERDRIVE CASE AND BRAKE INSPECT DISC, PLATE AND FLANGE

Check that the sliding surface of disc is not worn or burnt. If the disc is worn or burnt, replace all discs.

Then check that the sliding surfaces of plate and flange are not worn or burnt.

If necessary, replace them.

NOTE: Do not allow the discs to dry out.

Prepare new discs by soaking them at least two hours in ATF.

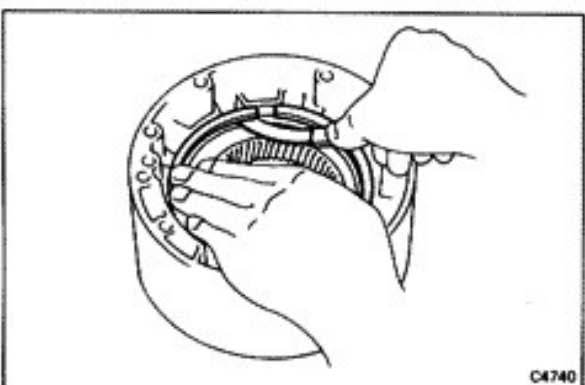
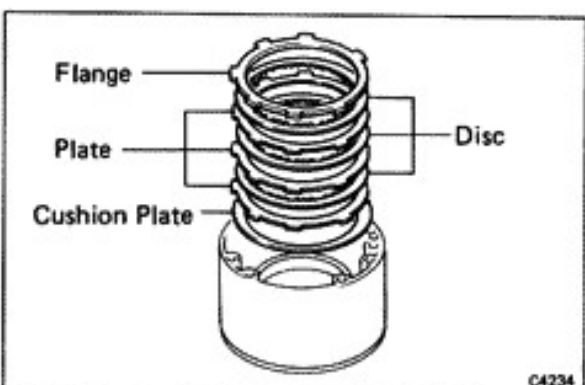
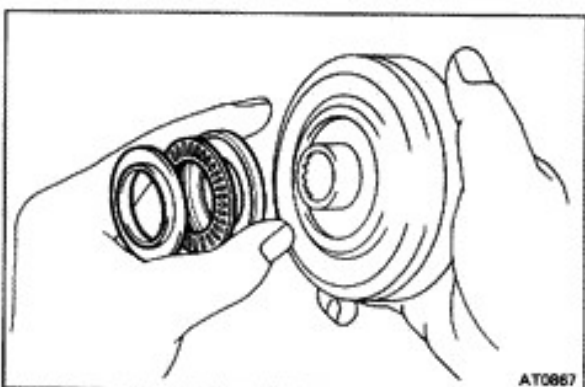
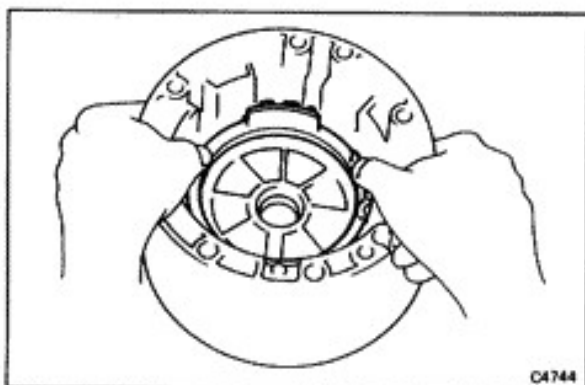
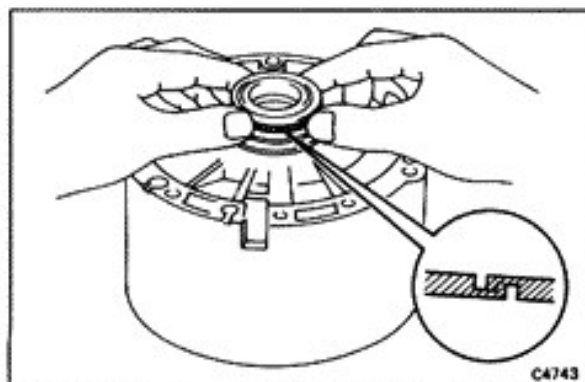

ASSEMBLY OF OVERDRIVE CASE AND BRAKE

(See page AT-60)

1. **INSTALL TWO OIL SEAL RINGS ON OVERDRIVE CASE**
Spread the rings apart and slide them into the groove. Hook both ends by hand.
2. **INSTALL NEW O-RING ON PISTON**
3. **INSTALL BRAKE PISTON IN OVERDRIVE CASE**
Install the piston with cup side up, being careful not to damage the O-rings.
4. **INSTALL TWELVE RETURN SPRINGS AND SET RETAINER AND SNAP RING IN PLACE**
Check that the ends of snap ring are not aligned with one of the cutouts.
5. **INSTALL THRUST BEARING AND RACES TO RING GEAR AND SET RING GEAR IN OVERDRIVE CASE**
NOTE: Make sure that the races are installed in correct direction.
6. **INSTALL CUSHION PLATE, DISCS, PLATES AND FLANGE**
Using low-pressure compressed air, blow all excess ATF from the discs.
CAUTION: High-pressure air will damage the discs.
Install in order: Cushion plate (rounded end down)-plate-disc-plate-disc-plate-disc-flange (flat side down)
7. **INSTALL SNAP RING**
Check that the ends of the snap ring are not aligned with one of the cutouts.
8. **MEASURE BRAKE CLEARANCE**
Measure the distance between the snap ring and flange.
Standard clearance: 0.40 — 1.38 mm
(0.0157 — 0.0543 in.)
9. **KEEP THRUST WASHER FOR ASSEMBLY**
The thrust washer left over will be installed later, as the transmission is assembled.

Front Clutch

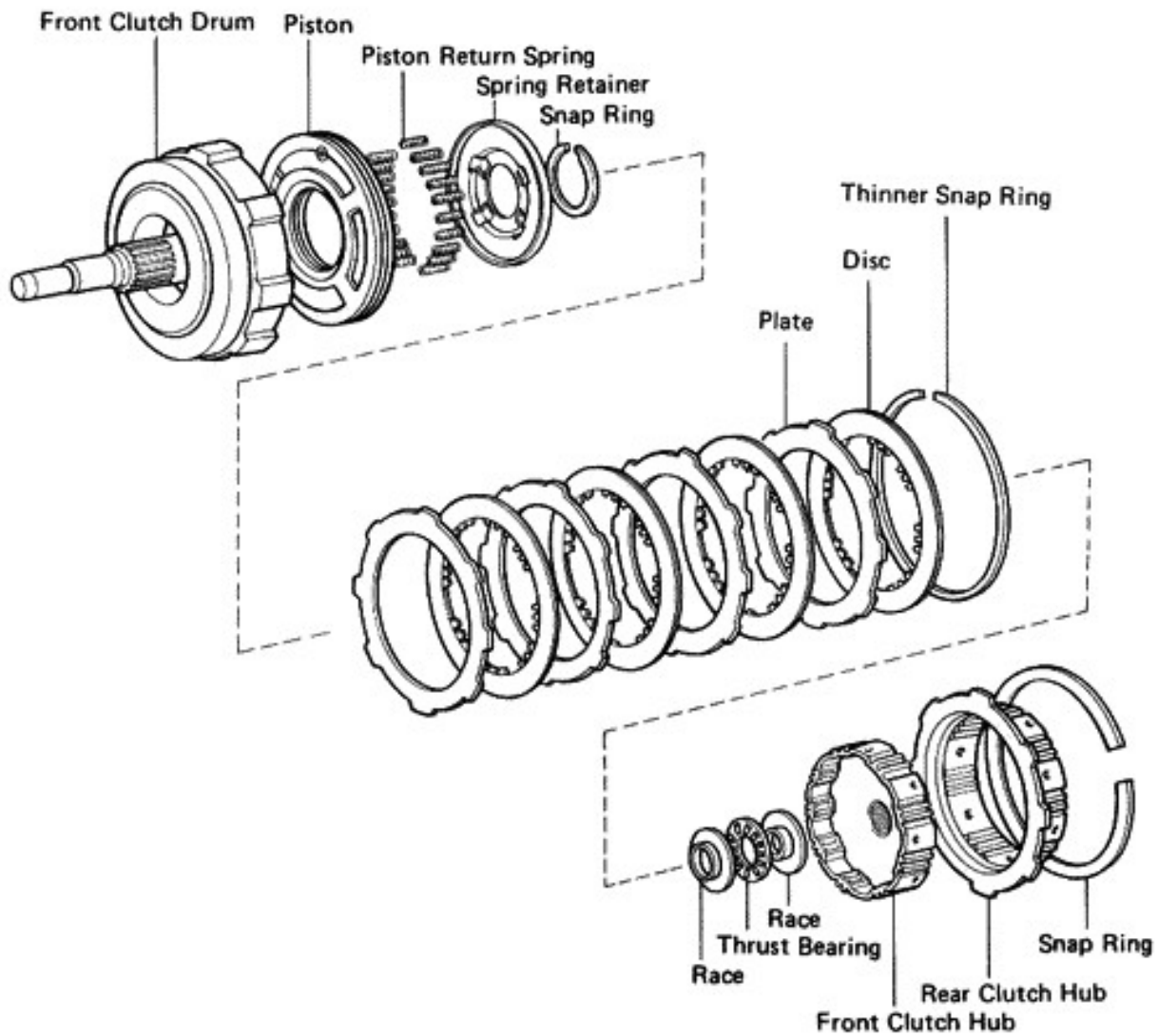

AT1862

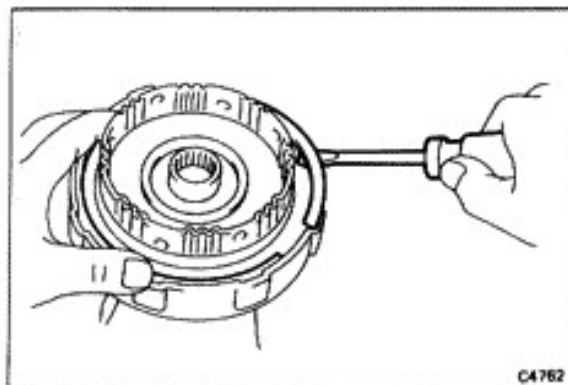

C4762

DISASSEMBLY OF FRONT CLUTCH

1. REMOVE THRUST BEARINGS AND RACES FROM BOTH SIDES OF CLUTCH

Note the position of the races.

2. USE EXTENSION HOUSING AS WORK STAND
3. REMOVE SNAP RING FROM FRONT CLUTCH DRUM

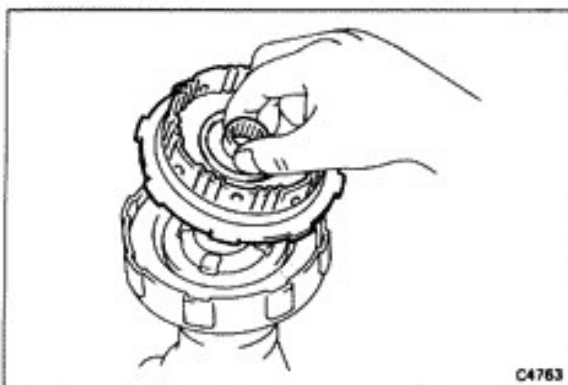

C4763

4. REMOVE FRONT AND REAR CLUTCH HUB

Lift out the two clutch hubs together.

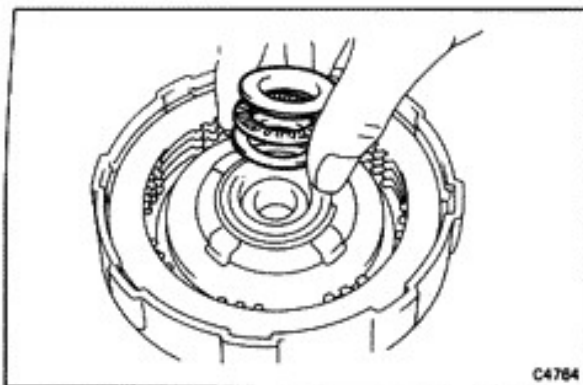

5. **REMOVE THRUST BEARING AND RACES**
Note the position of the races.

6. **REMOVE DISC**

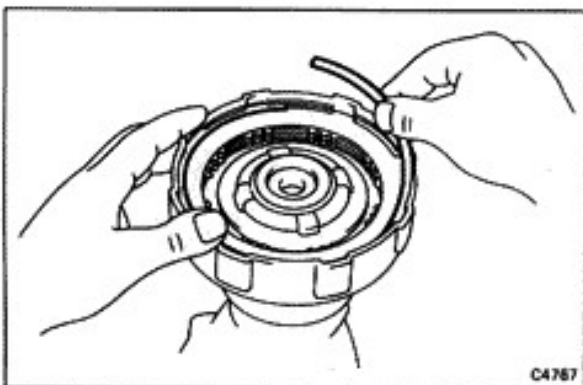

7. **REMOVE THINNER SNAP RING**

8. **REMOVE REMAINING CLUTCH PLATES AND DISCS**

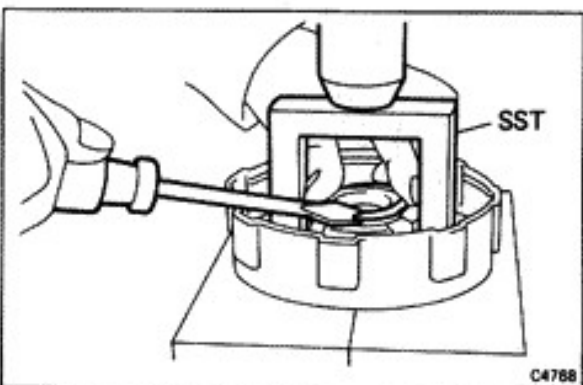

9. **COMPRESS PISTON RETURN SPRINGS AND REMOVE SNAP RING**

Place SST on the spring retainer and compress the springs with a shop press.

Remove the snap ring with a screwdriver.

SST 09350-20013 (09369-20040)

10. **REMOVE SPRING RETAINER AND EIGHTEEN SPRINGS**

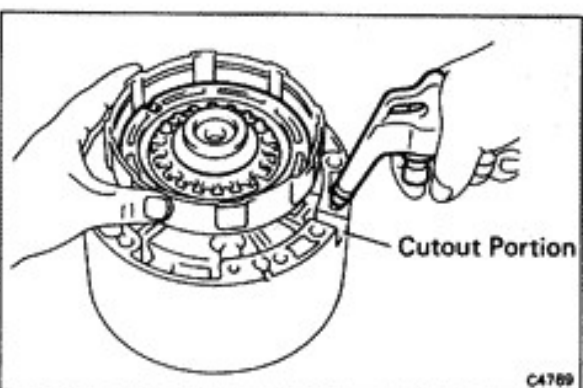

11. **ASSEMBLE FRONT CLUTCH ON OVERDRIVE CASE AND BLOW OUT PISTON**

(a) Slide the front clutch onto the overdrive case.

(b) Apply compressed air to the overdrive case to remove the piston. (If the piston does not come out, use pliers to remove it.)

(c) Remove the front clutch from the overdrive case.

12. **REMOVE O-RINGS FROM PISTON**

INSPECTION OF FRONT CLUTCH

1. **INSPECT FRONT CLUTCH PISTON**

(a) Check that the check ball is free by shaking the piston.

(b) Check that valve does not leak by applying low-pressure compressed air.

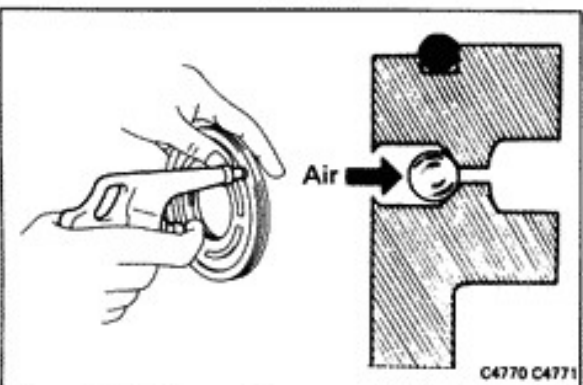

2. INSPECT DISC, PALTE AND FLANGE

Check that the sliding surface of disc is not worn or burnt. If the disc is worn or burnt, replace all discs. Then check that the sliding surfaces of plate and flange are not worn or burnt. If necessary, replace them.

NOTE: Do not allow the discs to dry out. Prepare new discs by soaking them at least two hours in ATF.

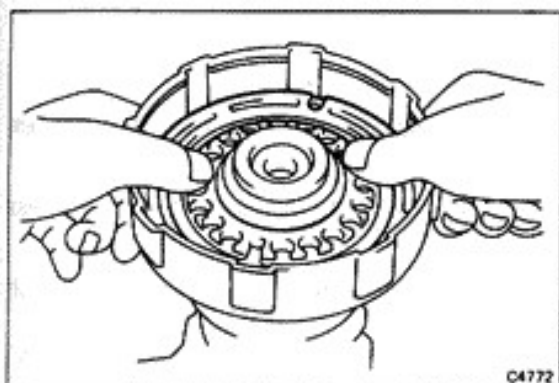

C4772

ASSEMBLY OF FRONT CLUTCH

(See page AT-63)

1. INSTALL NEW O-RINGS ON PISTON

2. INSTALL PISTON IN FRONT OF CLUTCH DRUM

Press the piston into the housing with the cup side up (check ball down). Be careful not to damage the O-rings.

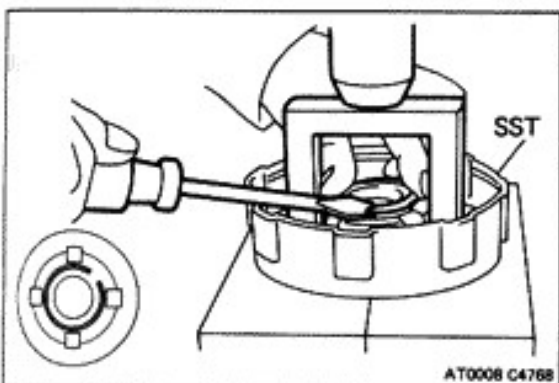

AT0008 C4768

3. INSTALL TWENTY PISTON RETURN SPRINGS, SPRING RETAINER AND SNAP RING IN PLACE

4. COMPRESS RETURN SPRINGS AND INSTALL SNAP RING IN GROOVE

(a) Place SST on the spring retainer, and compress the springs with a shop press.

SST 09350-20013 (09369-20040)

(b) Install the snap ring with a screwdriver.

5. INSTALL DISCS AND PLATES WITHOUT ASSEMBLING THINNER SNAP RING

(a) Do not assemble the thinner snap ring yet. (b) Using low-pressure compressed air, blow all excess ATF from the discs. For measurement of the clutch pack, install all plates and discs (temporarily without thinner snap ring).

CAUTION: High-pressure air will damage the discs.

Install in order: Plate-disc-plate-disc-plate-disc-plate (no snap ring)-disc

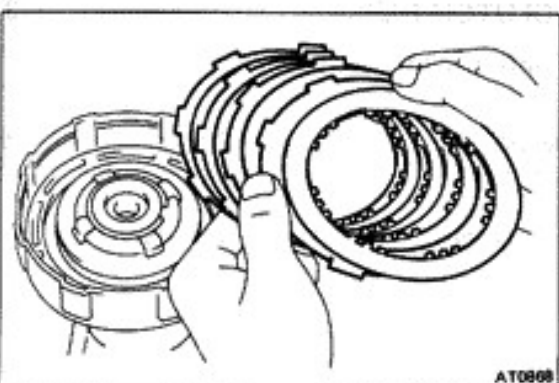

AT0868

6. CHECK PISTON STROKE OF FRONT CLUTCH

(a) Install the rear clutch hub and the outer snap ring. (b) Install the front clutch drum onto the overdrive case. With a dial indicator, measure the stroke applying and releasing the compressed air (4 — 8 kg/cm², 57 — 114 psi or 392 — 785 kPa) as shown.

Standard piston stroke: 1.40 — 2.24 mm (0.0551 — 0.0882 in.)

If not within specification, select a proper plate.

NOTE: There are two different thickness.

Plate thickness: 1.8 mm (0.071 in.)
2.0 mm (0.079 in.)

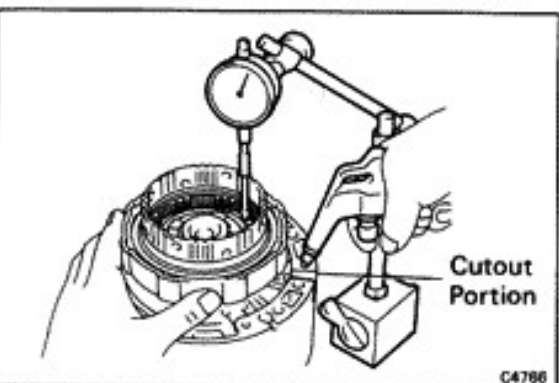

C4786

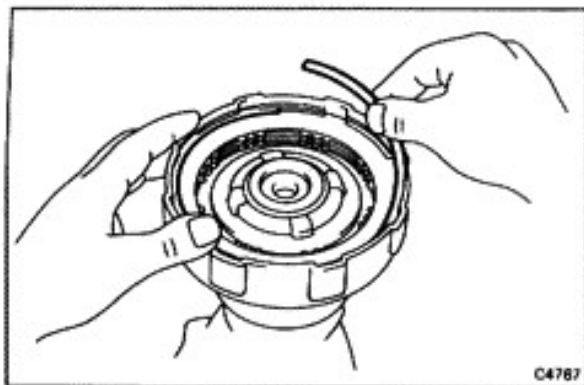

7. INSTALL THINNER SNAP RING IN CLUTCH DRUM

- Remove the outer snap ring, rear clutch hub and disc to allow installation of the thinner snap ring.
- Compress and lower the snap ring into the groove by hand. Check that the ends of the snap ring are not aligned with one of the cutouts.

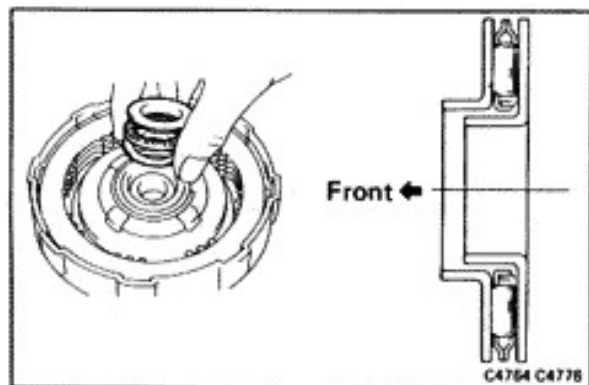

8. INSTALL DISC

9. INSTALL INNER THRUST BEARING AND RACES

IMPORTANT: Coat parts with petroleum jelly to hold them in place.

Install the inner race, needle bearing and outer race. Press them into place.

NOTE: Face the lip of race toward the front of the clutch body.

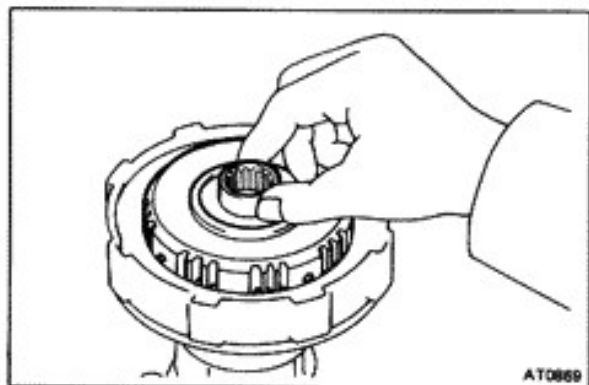

10. INSTALL FRONT CLUTCH HUB

Align the disc lugs with the hub teeth. Make sure the hub meshes with all discs and is fully inserted.

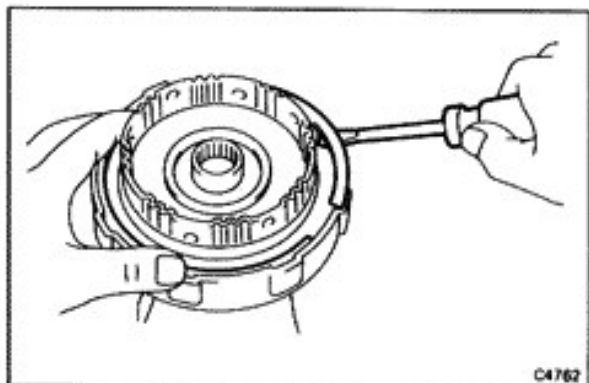

11. INSTALL REAR CLUTCH HUB AND OUTER SNAP RING

Check that the snap ring ends are not aligned with one of the cutouts.

NOTE: Note the position of the inner thrust bearing and races, and keep them together until assembly.

12. KEEP THRUST BEARINGS AND RACES TOGETHER

Rear Clutch

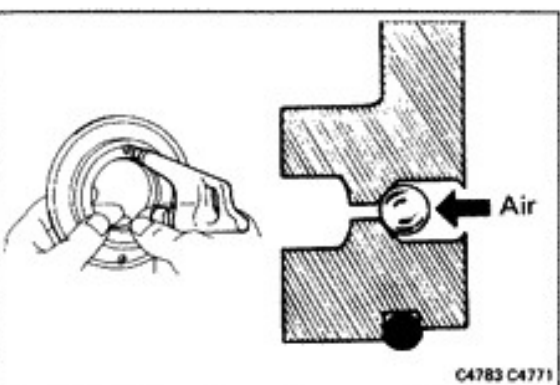
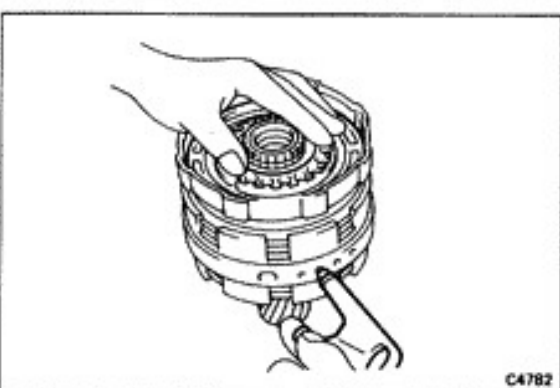
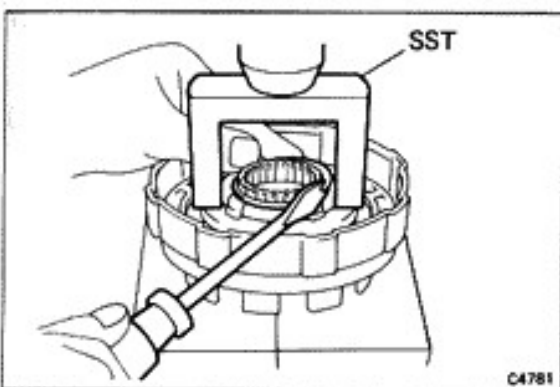
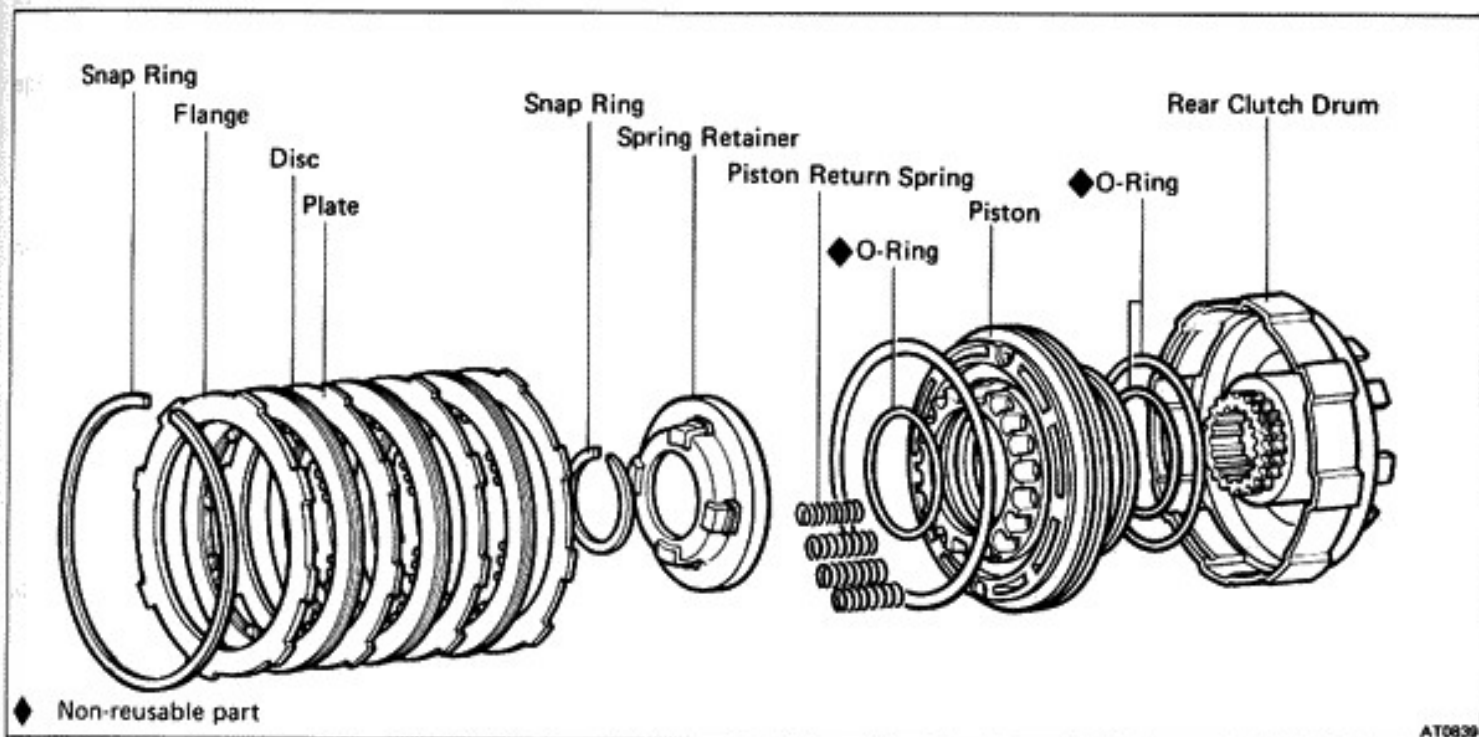

DISASSEMBLY OF REAR CLUTCH

1. REMOVE OUTER CLUTCH PACK RETAINING SNAP RING FROM DRUM
2. REMOVE CLUTCH FLANGE, DISCS AND PLATES
3. COMPRESS PISTON RETURN SPRINGS AND REMOVE SNAP RING

Place SST on the spring retainer and compress the springs with a shop press.

Using a screwdriver, remove the snap ring.

SST 09350-20013

4. REMOVE SPRING RETAINER, SNAP RING AND EIGHTEEN RETURN SPRINGS
5. ASSEMBLE REAR CLUTCH ON CENTER SUPPORT AND BLOW OUT PISTON

(a) Slide rear clutch onto the center support.

(b) Apply compressed air to center support to remove the piston. (If the piston does not come out, use pliers to remove it.)

(c) Remove the front clutch from the center support.

6. REMOVE O-RINGS FROM REAR CLUTCH PISTON

INSPECTION OF REAR CLUTCH

1. INSPECT REAR CLUTCH PISTON

(a) Check that check ball is free by shaking each piston.

(b) Check that the valve is not leaking by applying low-pressure compressed air.

2. INSPECT DISC, PLATE AND FLANGE

Check that the sliding surface of disc is not worn or burnt. If the disc is worn or burnt, replace all discs.

Then check that the sliding surfaces of plate and flange are not worn or burnt.

If necessary, replace them.

NOTE: Do not allow the discs to dry out.

Prepare new discs by soaking them at least two hours in ATF.

ASSEMBLY OF REAR CLUTCH

(See page AT-67)

1. INSTALL NEW O-RINGS ON PISTON**2. INSTALL REAR CLUTCH PISTON IN DRUM**

Press rear clutch piston into drum with the cup side up, being careful not to damage the O-rings.

3. INSTALL EIGHTEEN PISTON RETURN SPRINGS AND SET RETAINER WITH SNAP RING IN PLACE**4. COMPRESS RETURN SPRINGS AND INSTALL SNAP RING IN GROOVE**

(a) Place SST on the spring retainer, and compress the springs on shop press.

SST 09350-20013 (09369-20040)

(b) Install the snap ring with snap ring pliers.

5. INSTALL DISCS, PLATES AND FLANGE

Using low-pressure compressed air, blow all excess ATF from discs.

CAUTION: High-pressure air will damage the discs.

Install in order: Plate-disc-plate-disc-plate-disc-flange (flat end down)

6. INSTALL SNAP RING

Check that the snap ring ends are not aligned with one of the cutouts.

7. CHECK PISTON STROKE OF REAR CLUTCH

Install the rear clutch onto the center support. With a dial indicator, measure the stroke applying and releasing the compressed air (4 — 8 kg/cm², 57 — 114 psi or 392 — 785 kPa) as shown.

Standard piston stroke: 0.90 — 1.75 mm
(0.0354 — 0.0689 in.)

If not within specification, select a proper flange. There are three different thickness.

Flange thickness: 3.6 mm, 3.8 mm, 4.0 mm
(0.142 in., 0.150 in., 0.157 in.)

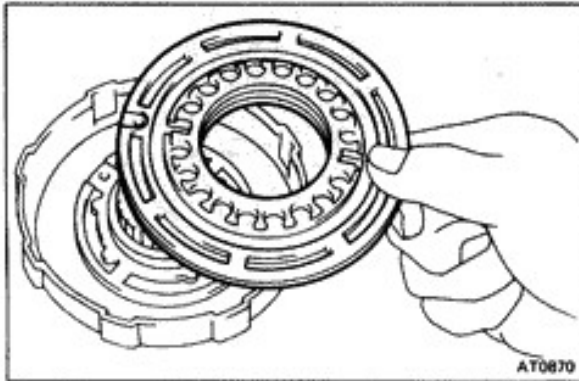

AT0870

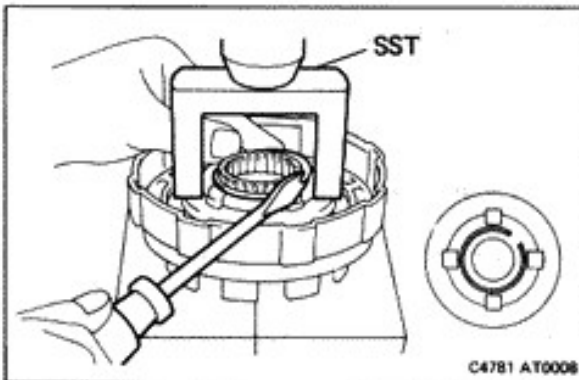

C4781 AT0008

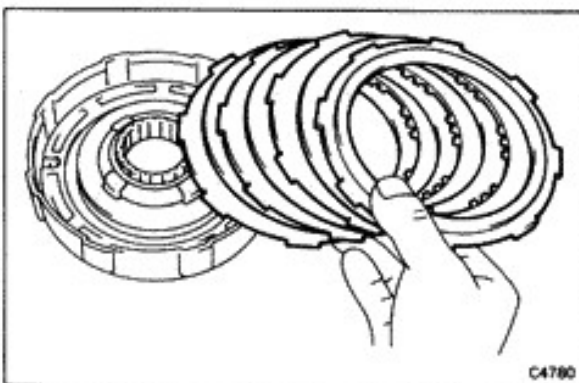

C4780

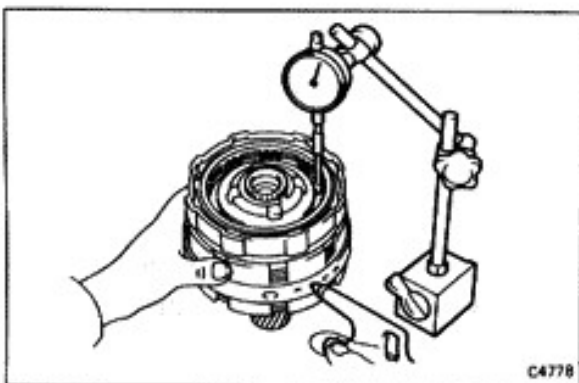

C4778

Center Support Assembly

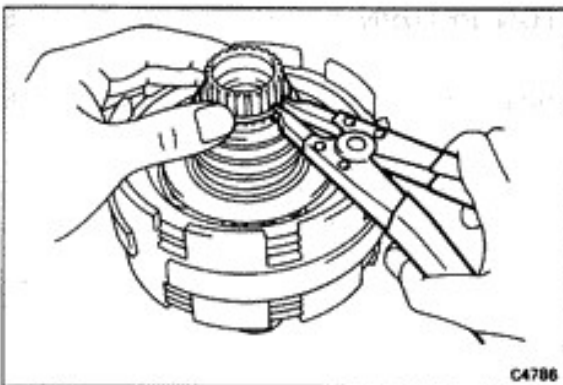
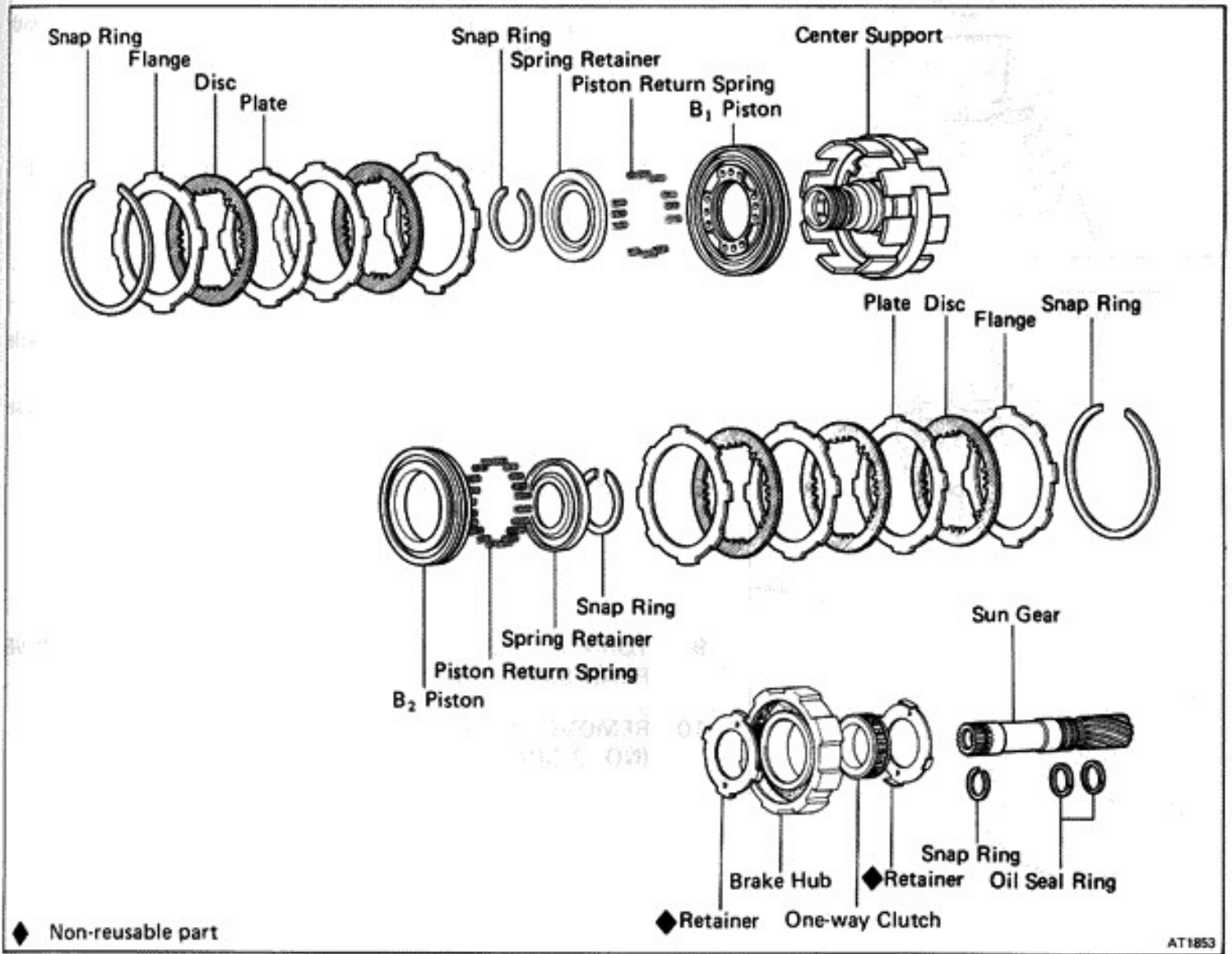

DISASSEMBLY OF CENTER SUPPORT ASSEMBLY

1. REMOVE SNAP RING FROM END OF SUN GEAR SHAFT
2. PULL CENTER SUPPORT ASSEMBLY FROM SHAFT

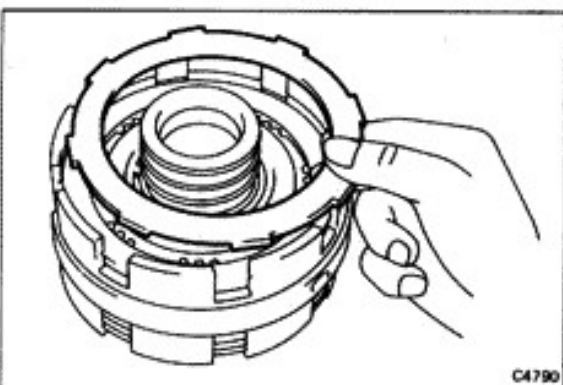

3. REMOVE SNAP RING FROM FRONT OF CENTER SUPPORT ASSEMBLY (NO. 1 BRAKE)
4. REMOVE CLUTCH FLANGE, DISCS AND PLATES (NO. 1 BRAKE)

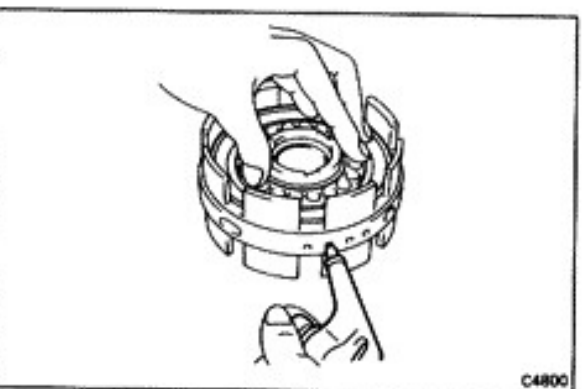
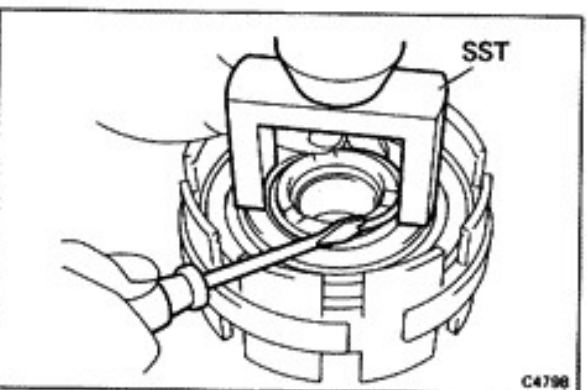
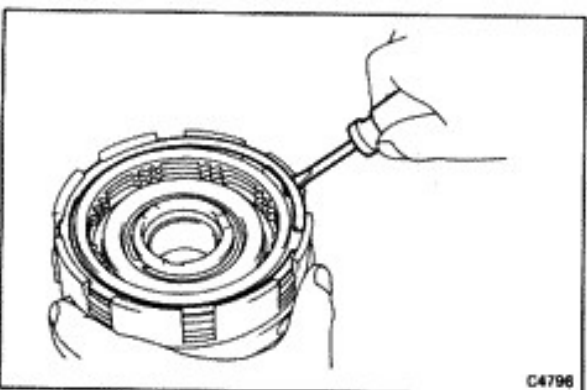
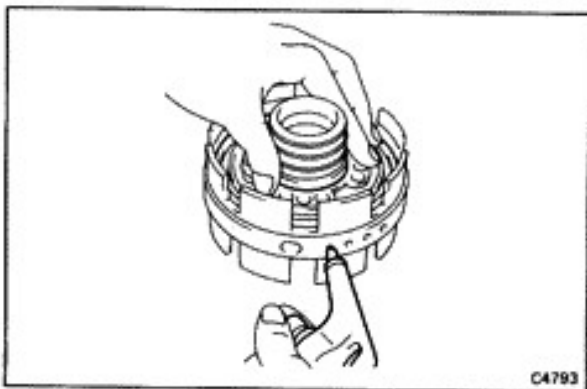
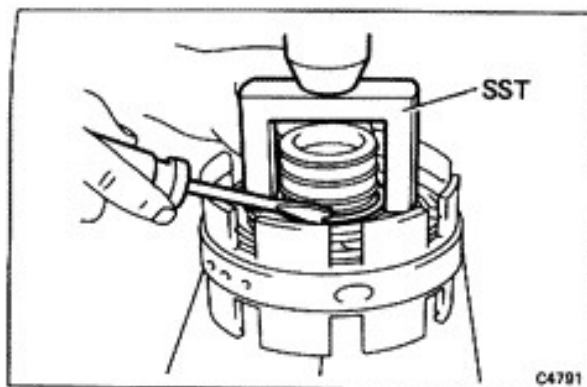

5. COMPRESS PISTON RETURN SPRINGS AND REMOVE SNAP RING

Place SST on spring retainer and compress the springs with a shop press.

Using a screwdriver, remove the snap ring.

SST 09350-20013 (09369-20040)

6. REMOVE SPRING RETAINER AND TWELVE SPRINGS

7. REMOVE NO. 1 BRAKE PISTON

Blow compressed air through the center support oil hole to remove the No. 1 brake piston.

If the piston does not pop out, lift it out with needle-nose pliers.

8. REMOVE NO. 1 BRAKE PISTON O-RINGS

9. TURN CENTER SUPPORT ASSEMBLY OVER AND REMOVE REAR SNAP RING (NO. 2 BRAKE)

10. REMOVE CLUTCH FLANGE, DISCS AND PLATES (NO. 2 BRAKE)

11. COMPRESS PISTON RETURN SPRINGS AND REMOVE SNAP RING

Place SST on spring retainer and compress the springs with a shop press.

Using a screwdriver, remove the snap ring.

SST 09350-20013 (09369-20040)

12. REMOVE SPRING RETAINER AND TWENTY SPRINGS

13. REMOVE NO. 2 BRAKE PISTON

Blow compressed air through the center support oil hole to remove the No. 2 brake piston.

If the piston does not pop out, lift it out with needle-nose pliers.

14. REMOVE NO. 2 BRAKE PISTON O-RINGS

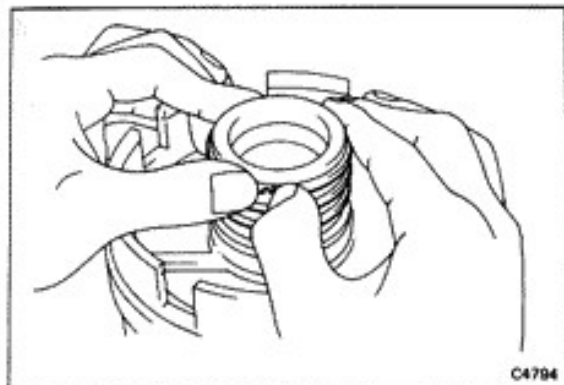

15. REMOVE THREE OIL SEAL RINGS FROM CENTER SUPPORT

CAUTION: Do not spread the ring ends too much.

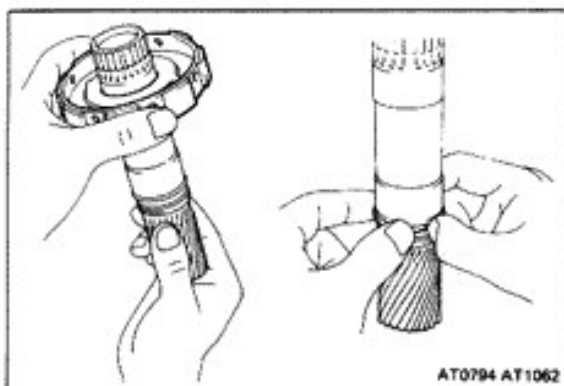

16. REMOVE ONE-WAY CLUTCH ASSEMBLY AND OIL SEAL RINGS FROM SUN GEAR

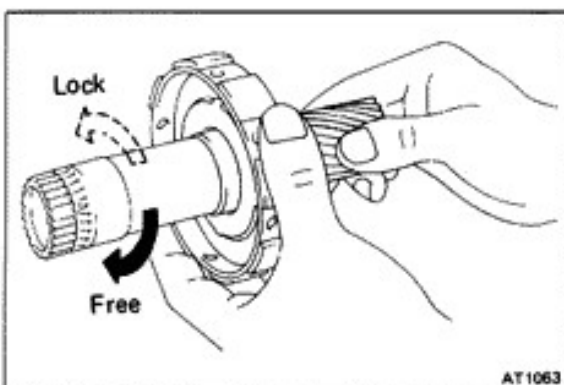

INSPECTION OF CENTER SUPPORT ASSEMBLY

1. CHECK OPERATION OF ONE-WAY CLUTCH

Hold the No. 2 brake hub and turn the sun gear. The sun gear should turn freely counterclockwise and should lock clockwise.

If the one-way clutch does not work properly, replace it.

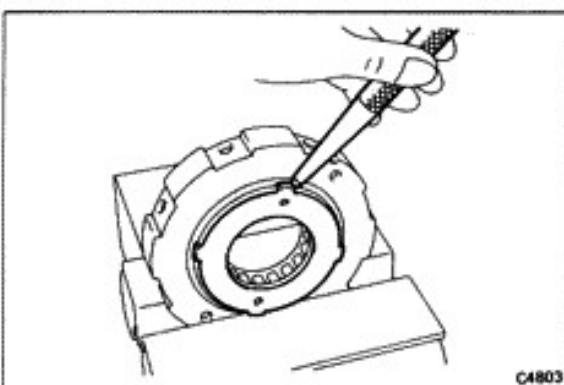

2. IF NECESSARY, REPLACE ONE-WAY CLUTCH

- (a) Bend several tabs back with a tapered punch.
- (b) Pry off the retainer with a screwdriver. Leave the other retainer on the hub.
- (c) Remove the one-way clutch.

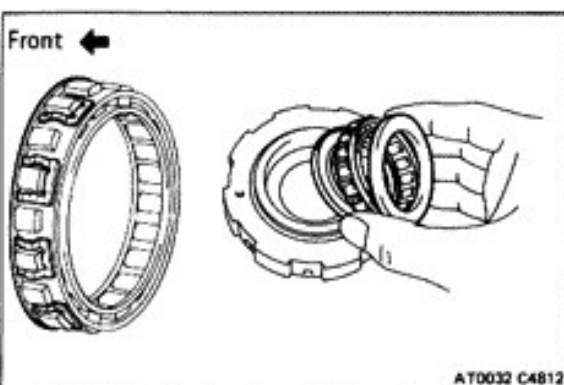

- (d) Install the one-way clutch into the brake hub, facing the spring cage toward the front.

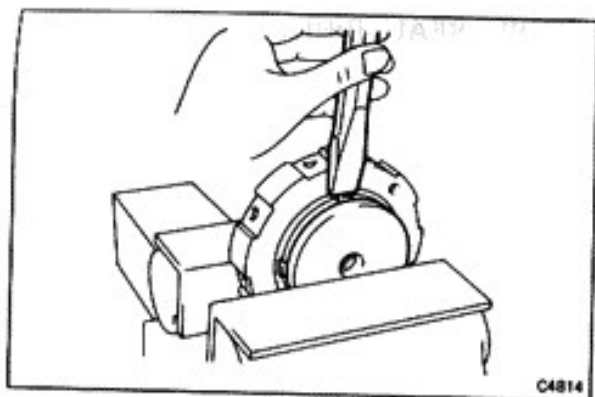

- (e) Hold the brake hub in a vise with soft jaws, and flatten the ears with a chisel.
- (f) Check to make sure that the retainer is centered.

3. INSPECT DISC, PLATE AND FLANGE

Check that the sliding surface of disc is not worn or burnt.

If the disc is worn or burnt, replace all discs.

Then check that the sliding surfaces of plate and flange are not worn or burnt.

If necessary, replace them.

NOTE: Do not allow the discs to dry out.

Prepare new discs by soaking them at least two hours in ATF.

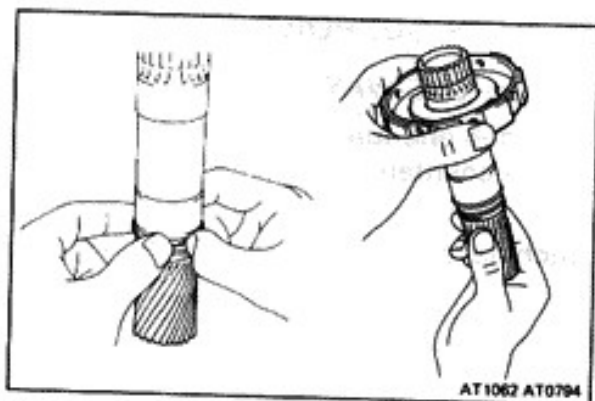

ASSEMBLY OF CENTER SUPPORT ASSEMBLY

(See page AT-69)

1. **INSTALL TWO OIL SEAL RINGS AND ONE-WAY CLUTCH ASSEMBLY ON SUN GEAR**

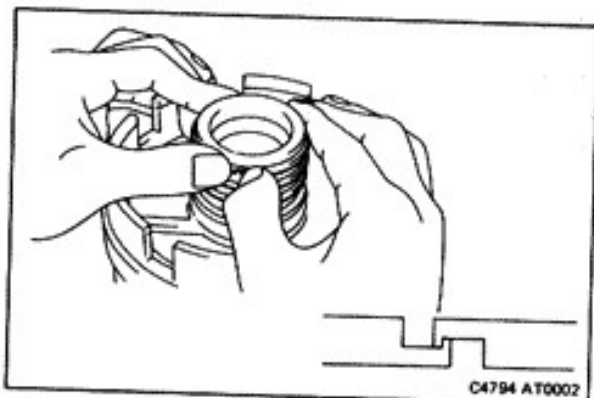

2. **INSTALL THREE OIL SEAL RINGS ON CENTER SUPPORT**
Spread the rings apart and slip them into the groove. Hook both ends by hand.

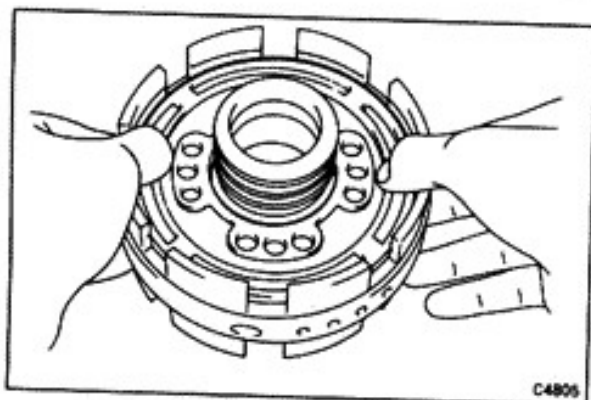

3. **INSTALL NEW O-RINGS ON PISTON**
4. **INSTALL NO. 1 BRAKE PISTON IN CENTER SUPPORT**
Press the No. 1 brake piston into the center support with the cup side up, being careful not to damage the O-rings.

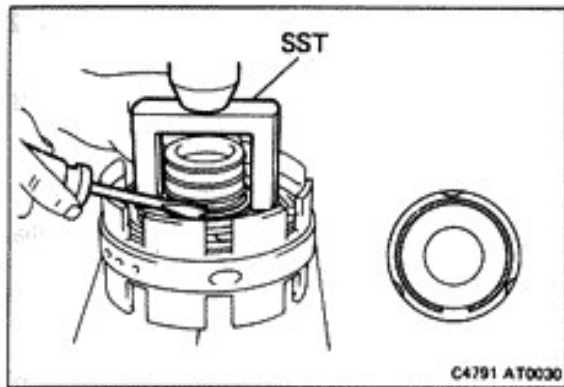

5. INSTALL TWELVE PISTON RETURN SPRINGS AND SET RETAINER WITH SNAP RING IN PLACE

6. COMPRESS RETURN SPRINGS AND INSTALL SNAP RING IN GROOVE

(a) Place SST on the spring retainer, and compress the springs on a shop press.

SST 09350-20013 (09369-20040)

(b) Install the snap ring using a screwdriver.

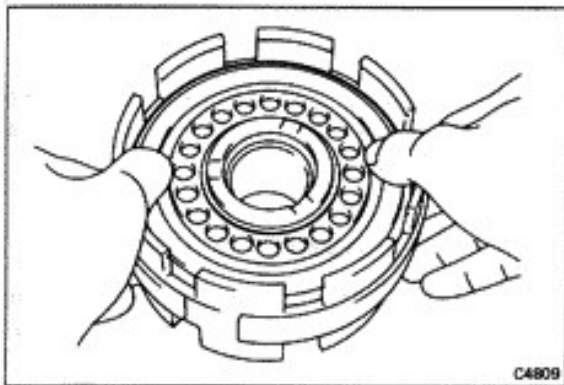

7. INSTALL NEW O-RINGS ON PISTON AND CENTER SUPPORT

8. TURN CENTER SUPPORT OVER AND INSTALL NO. 2 BRAKE PISTON

Press the No. 2 brake piston into the center support with the cup side up, being careful not to damage the O-rings.

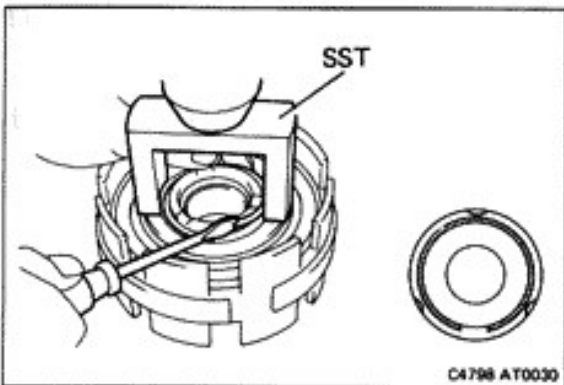

9. INSTALL TWENTY PISTON RETURN SPRINGS AND SET RETAINER WITH SNAP RING IN PLACE

10. COMPRESS RETURN SPRINGS AND INSTALL SNAP RING IN GROOVE

(a) Place SST on the spring retainer, and compress the springs on a shop press.

SST 09350-20013 (09369-20040)

(b) Install the snap ring with a screwdriver.

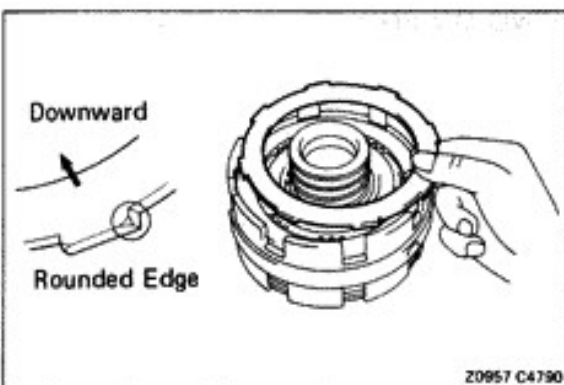

11. TURN CENTER SUPPORT OVER AND INSTALL NO. 1 BRAKE PISTON PLATE, DISC AND FLANGE

Using the low-pressure compressed air, blow all excess ATF from the disc.

CAUTION: High-pressure air will damage the disc.

Install in order: Plate-disc-plate-plate-disc-flange (rounded edge down)

12. INSTALL SNAP RING IN CENTER SUPPORT

Check that snap ring ends are not aligned with one of the cutouts.

13. CHECK PISTON STROKE OF NO. 1 BRAKE

With a dial indicator, measure the stroke applying and releasing the compressed air (4 – 8 kg/cm², 57 – 114 psi or 392 – 785 kPa) as shown.

Standard piston stroke: 0.80 – 1.73 mm
(0.0315 – 0.0681 in.)

If the stroke exceeds the limit, the clutch pack is probably worn. If the stroke is less than the limit, parts may be mis-assembled or there may be excess ATF on the discs.

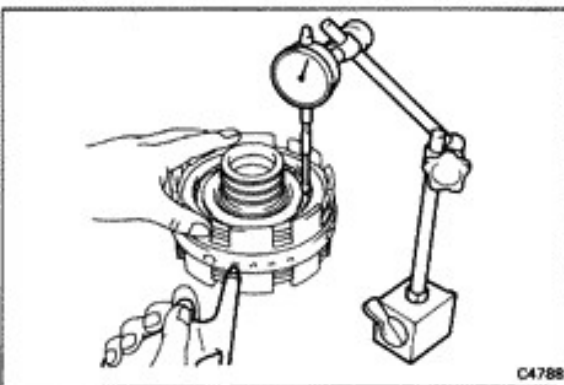

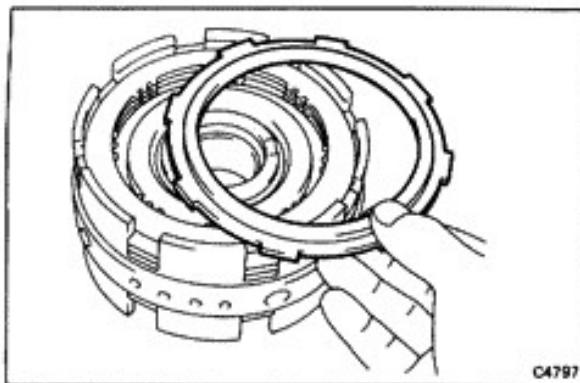

C4797

14. TURN CENTER SUPPORT OVER AND INSTALL NO. 2 BRAKE PLATES, DISCS AND FLANGE

Using the low-pressure compressed air, blow all excess ATF from the discs.

CAUTION: High-pressure air will damage the disc.

Install in order: Plate-disc-plate-disc-plate-disc-flange (flat side down)

15. INSTALL SNAP RING IN CENTER SUPPORT

Check that the snap ring ends are not aligned with one of the cutouts.

16. CHECK PISTON STROKE OF NO. 2 BRAKE

With a dial indicator, measure the stroke applying and releasing the compressed air (4 — 8 kg/cm², 57 — 114 psi or 392 — 785 kPa) as shown.

Standard piston stroke: 1.01 — 2.25 mm
(0.0398 — 0.0886 in.)

If the stroke exceeds the limit, the clutch pack is probably worn. If the stroke is less than the limit, parts may be mis-assembled or there may be excess ATF on the discs.

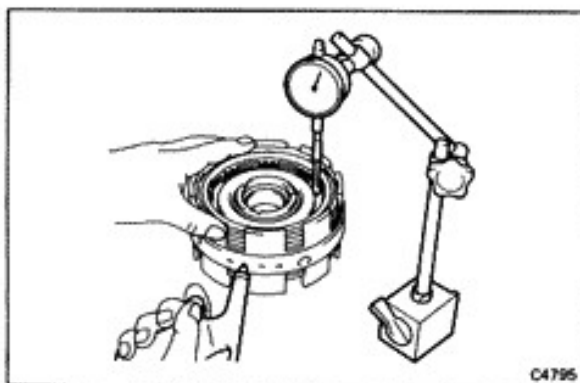

C4796

17. ASSEMBLE CENTER SUPPORT AND SUN GEAR SHAFT

(a) Align the brake No. 2 disc flukes.

(b) Mesh the brake hub with the discs, twisting and jiggling the hub as required.

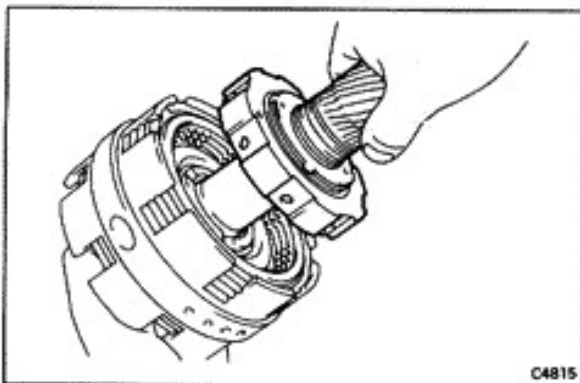

C4815

18. INSTALL SNAP RING ON END OF SUN GEAR SHAFT

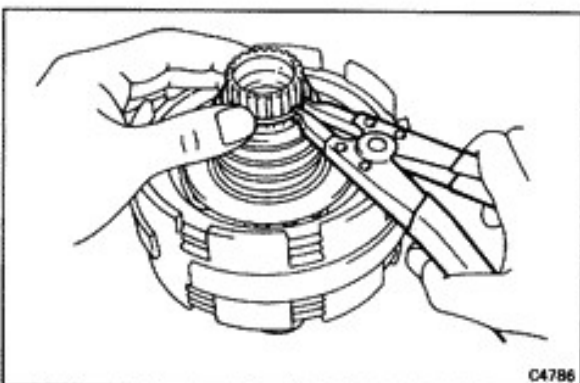

C4786

Planetary Gear Output Shaft

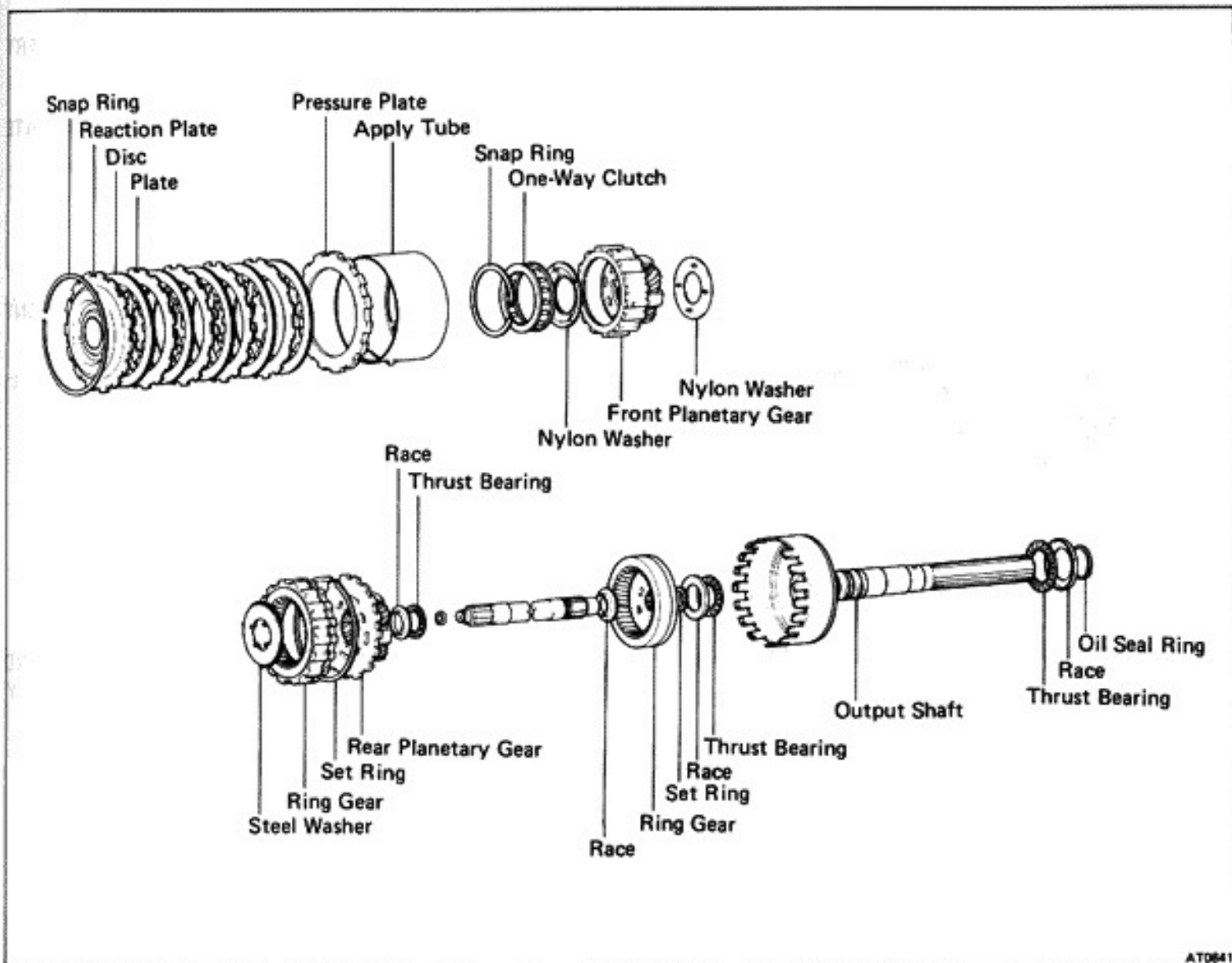

AT0641

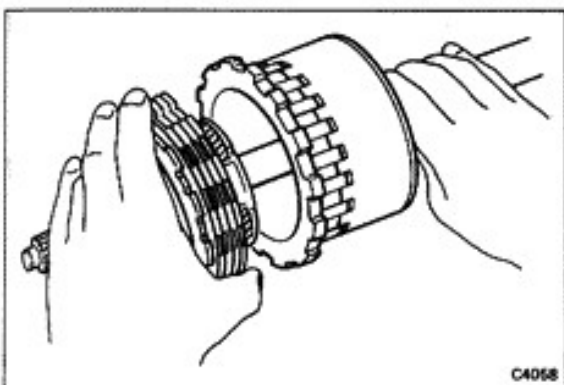

C4058

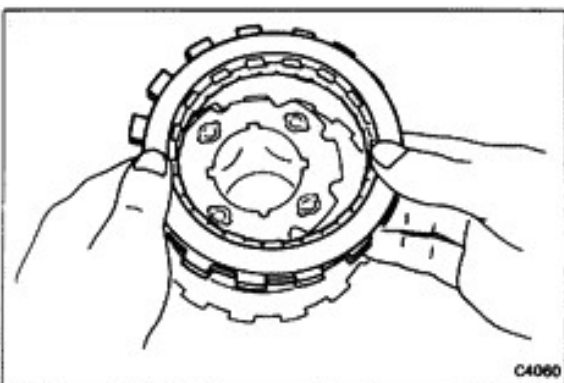

C4060

DISASSEMBLY OF PLANETARY GEAR OUTPUT SHAFT

1. **REMOVE NO. 3 BRAKE DISC/PLATE PACK AND FRONT PLANETARY PINION GEARS**
Grasp the components and pull off the front end of the output shaft.
Be careful to avoid dropping the bearing on the output shaft.
2. **REMOVE THRUST WASHER FROM PLANETARY GEARS**
NOTE: The thrust washer may have stuck to the inside of the planetary gear case.
3. **REMOVE BRAKE DISCS AND PLATES FROM PLANETARY GEARS**
4. **REMOVE REACTION PLATE FROM PLANETARY GEARS**

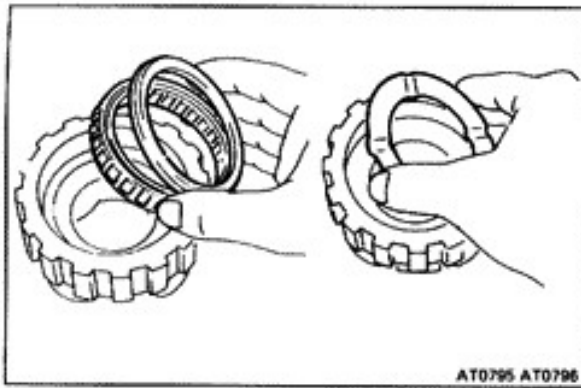

5. **REMOVE SNAP RING AND ONE-WAY CLUTCH FROM PLANETARY GEARS**
6. **REMOVE NYLON THRUST WASHER FROM PLANETARY GEARS**
7. **REMOVE APPLY TUBE AND CLUTCH PRESSURE PLATE**

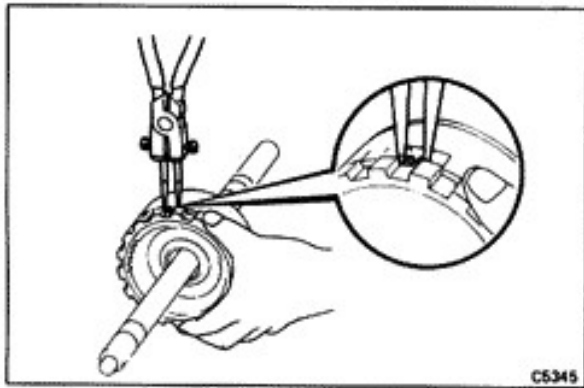

8. **COMPRESS SHAFT SNAP RING AND REMOVE FRONT PLANETARY RING GEAR**

While pulling up the ring gear, compress the snap ring with snap ring pliers and pull out the ring gear by hand.

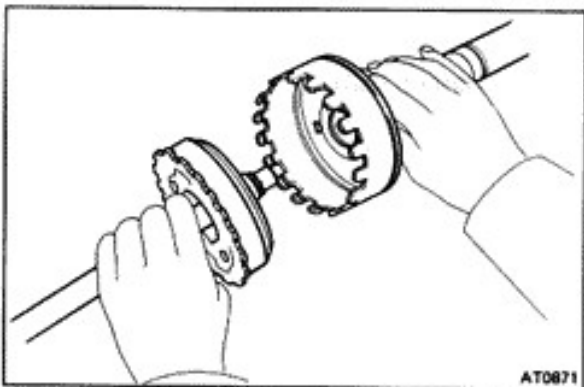

9. **REMOVE INTERMEDIATE SHAFT, RING GEAR AND PLANETARY GEAR FROM OUTPUT SHAFT ASSEMBLY**

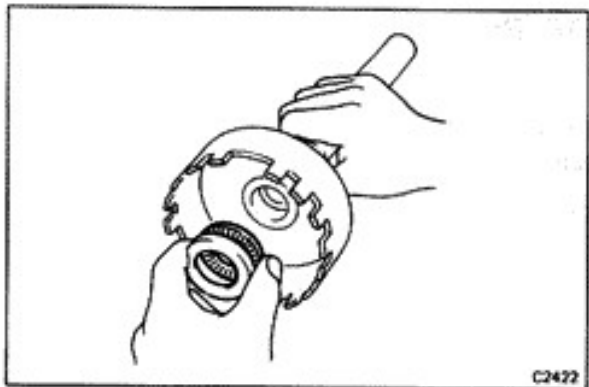

10. **REMOVE THRUST BEARING AND RACES FROM OUTPUT SHAFT ASSEMBLY**

Note the position of the races.

11. **REMOVE THREE OIL SEAL RINGS FROM OUTPUT SHAFT**

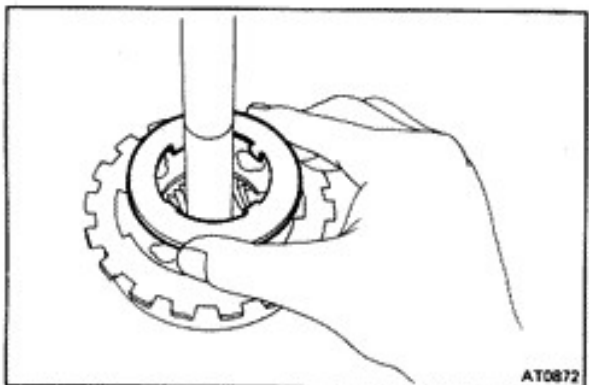

12. **REMOVE STEEL THRUST WASHER AND REAR PINION GEARS FROM INTERMEDIATE SHAFT ASSEMBLY**

13. **REMOVE RACE AND THRUST BEARING FROM INTERMEDIATE SHAFT**

Note the position of the race.

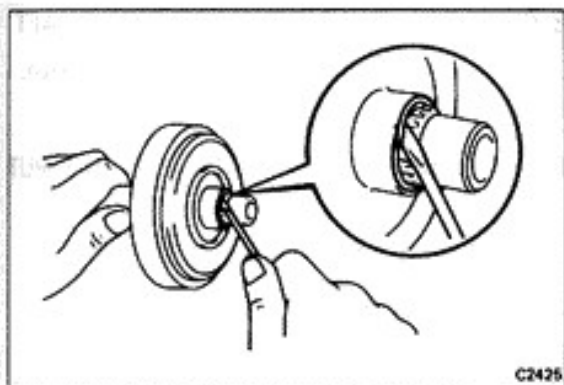

14. INVERT INTERMEDIATE SHAFT AND REMOVE SET RING

15. REMOVE REAR PLANETARY RING GEAR AND BEARING RACE FROM INTERMEDIATE SHAFT

Note the position of the race.

INSPECTION OF PLANETARY GEAR OUTPUT SHAFT

INSPECT DISK, PLATE AND FLANGE

Check that the sliding surface of disc is not worn or burnt. If the disc is worn or burnt, replace all discs.

Then check that the sliding surface of plate is not worn or burnt.

If necessary, replace them.

NOTE: Do not allow the discs to dry out. Prepare new discs by soaking them at least two hours in ATF.

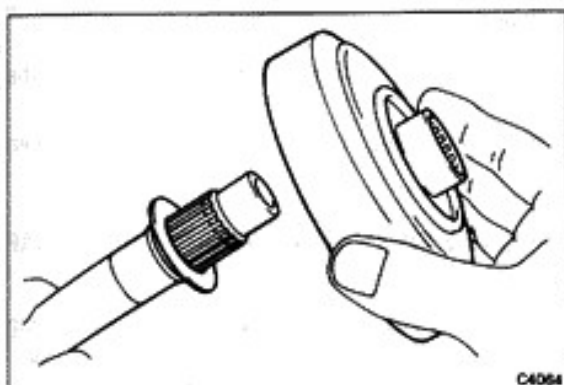

ASSEMBLY OF PLANETARY GEAR OUTPUT SHAFT

(See page AT-75)

1. INSTALL THRUST BEARING RACE AND REAR PLANETARY RING GEAR ON INTERMEDIATE SHAFT

Slip the thrust bearing race and ring gear onto the shaft with the exterior splines up, as shown.

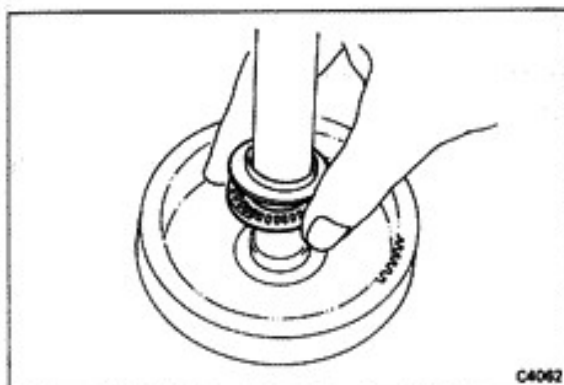

2. INSTALL SET RING ON INTERMEDIATE SHAFT

Push down and wind the set ring into place. Check to make sure it is secure.

3. TURN OVER INTERMEDIATE SHAFT AND INSTALL THRUST BEARING AND RACE

Make sure the flat side of the race is against the bearing.

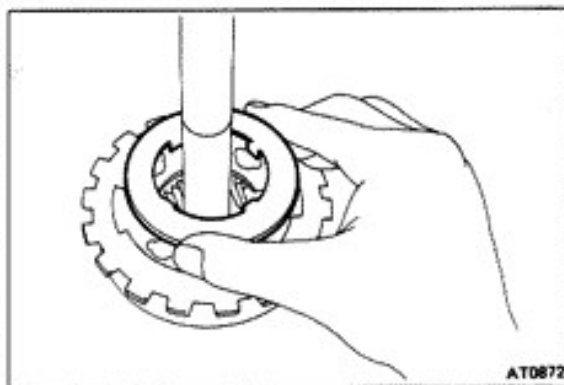

4. INSTALL PINION GEAR ASSEMBLY AND STEEL THRUST WASHER ON REAR PLANETARY CARRIER

Install the washer with the lugs down, fitting into the rear planetary gear carrier.

CAUTION: Make sure the different lug shapes match the openings on the plate.

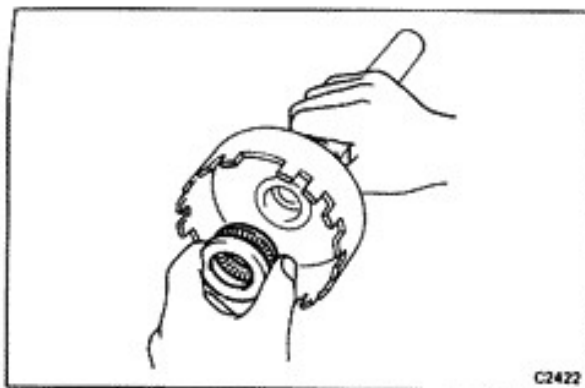

C2422

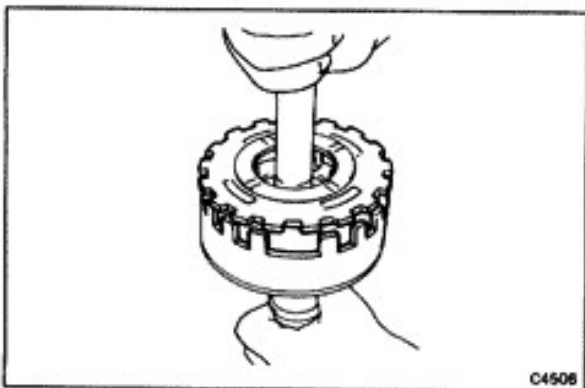

C4508

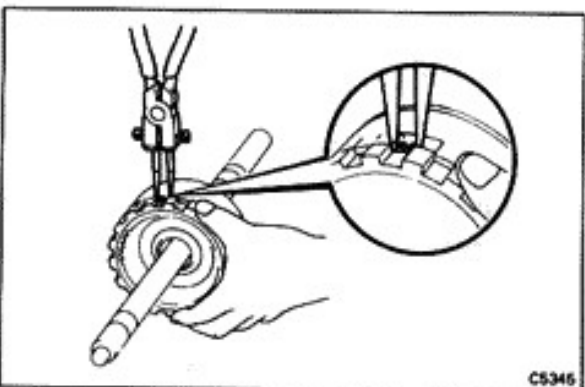

C5346

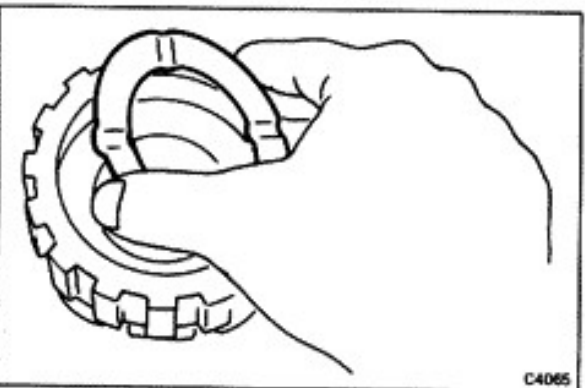

C4065

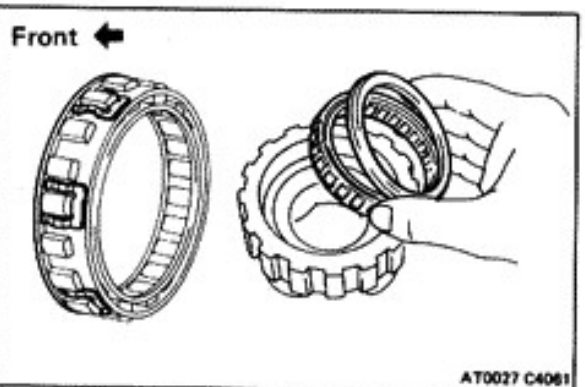

AT0027 C4061

5. **INSTALL THREE OIL SEAL RINGS ON OUTPUT SHAFT**
Spread the rings apart and slide them into the groove. Hook both ends by hand.
6. **INSTALL THRUST BEARING AND RACE ON OUTPUT SHAFT**
Hold the cup of the race toward the bearing.
7. **USE EXTENSION HOUSING AS ASSEMBLY STAND**
8. **INSTALL INTERMEDIATE SHAFT ASSEMBLY IN OUTPUT SHAFT**
9. **INSTALL REAR PLANETARY CARRIER IN OUTPUT SHAFT**
Slide the carrier into place, and make sure that the lugs interlock.
10. **SET IN PLACE FRONT PLANETARY RING GEAR**
Slide the snap ring downward, and align the lugs with the notches.
Align the ends of the snap ring with the wide gap between the teeth.
11. **INSTALL FRONT PLANETARY RING GEAR WITH SNAP RING**
While pushing down the ring gear, squeeze the snap ring end with snap ring pliers and install it into the groove.
NOTE: When the snap ring is fully seated, the gap is the width of one lug.
12. **INSTALL NYLON THRUST WASHER IN FRONT PLANETARY PINION GEAR**
Face the lugs downward and match them with the slots in back of the planetary gear.
13. **INSTALL ONE-WAY CLUTCH**
Install the one-way clutch into the outer race, facing the spring cage toward the front.

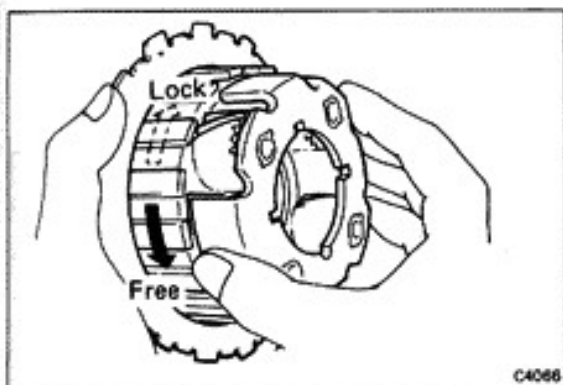

14. TEMPORARILY INSTALL REACTION PLATE ON PLANETARY

Insert the plate into place for testing of the one-way clutch.

15. TEST ONE-WAY CLUTCH

The planetary gear must rotate freely counterclockwise and lock clockwise.

If the clutch does not work correctly, it must be replaced.

16. REMOVE REACTION PLATE

17. INSTALL NYLON THRUST WASHER ON FRONT PLANETARY CARRIER

Apply petroleum jelly to the washer to hold it in place during later assembly. Match the lugs with the planetary carrier.

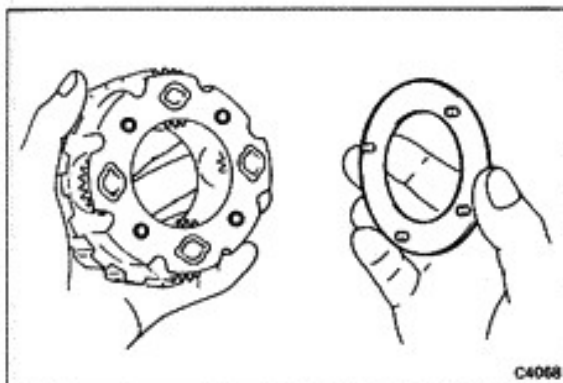

18. INSTALL FRONT PLANETARY GEAR ASSEMBLY TO INTERMEDIATE SHAFT

19. INSTALL PRESSURE PLATE

Install the pressure plate, facing the flat surface toward the intermediate shaft.

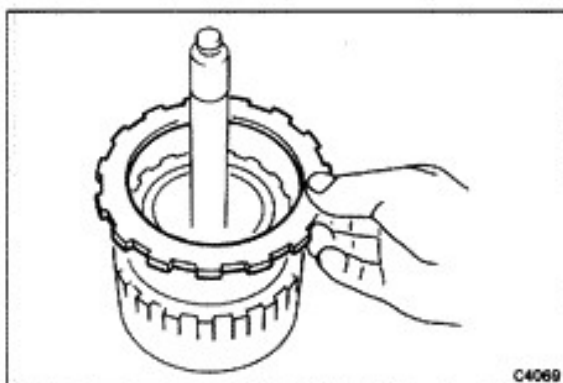

20. INSTALL NO. 3 BRAKE CLUTCH PACK

Using low-pressure compressed air, blow all excess ATF from discs.

CAUTION: High-pressure air will damage the discs.

Install in order: Disc-plate-disc-plate-disc-plate-disc-plate-disc

21. KEEP INNER RACE, APPLY TUBE, THRUST BEARING AND RACE TOGETHER

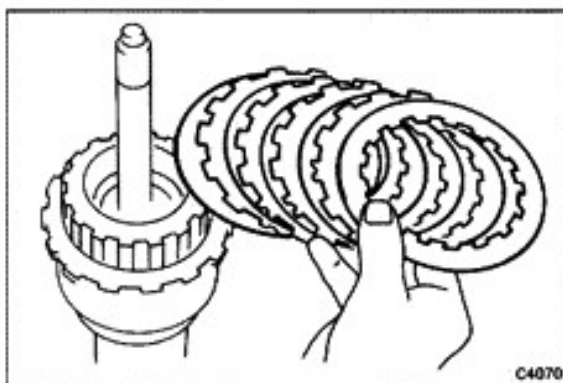

Transmission Case and Rear Brake Pistons

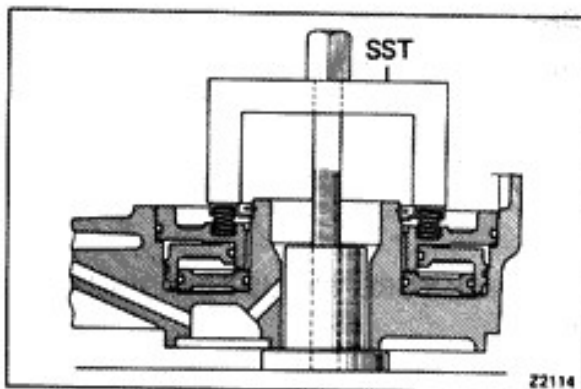
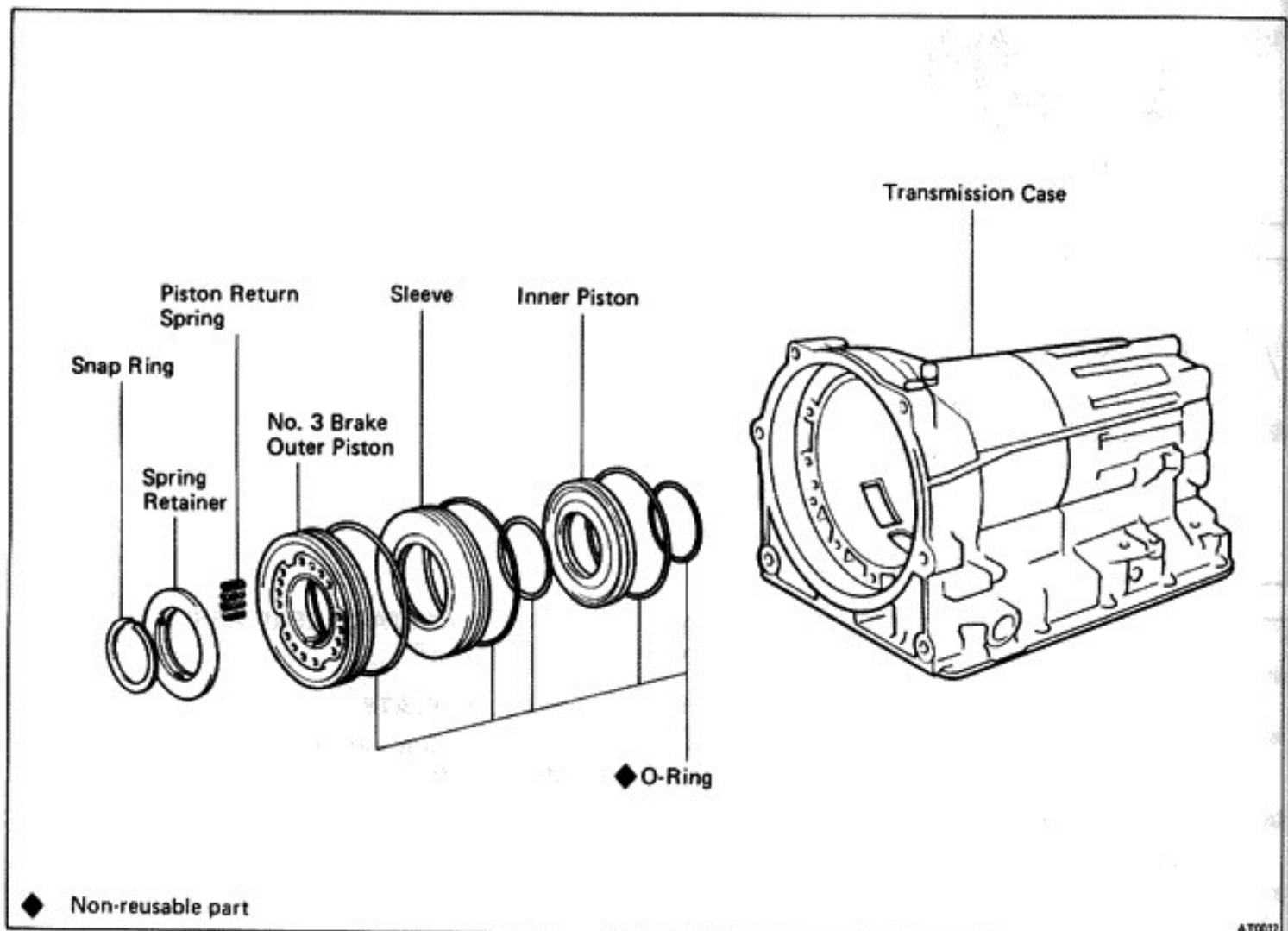

DISASSEMBLY OF TRANSMISSION CASE AND REAR BRAKE PISTONS

1. COMPRESS RETURN SPRINGS AND REMOVE SPRING RETAINER SNAP RING

- (a) Install the SST. Gradually and evenly tighten the bolt to compress the springs, being careful not to damage the transmission case with SST.

SST 09350-20013 (09369-20040)

- (b) Using a screwdriver and hook, remove the snap ring.

2. REMOVE SPRING RETAINER AND SIXTEEN SPRINGS

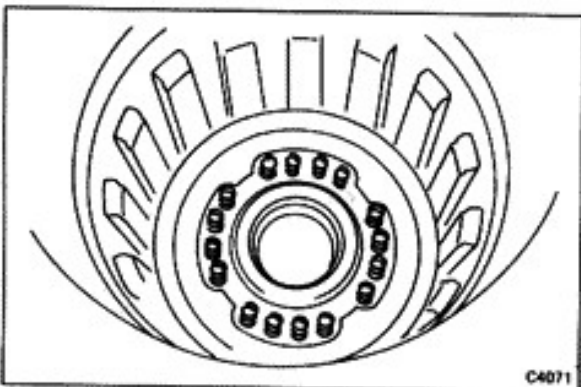

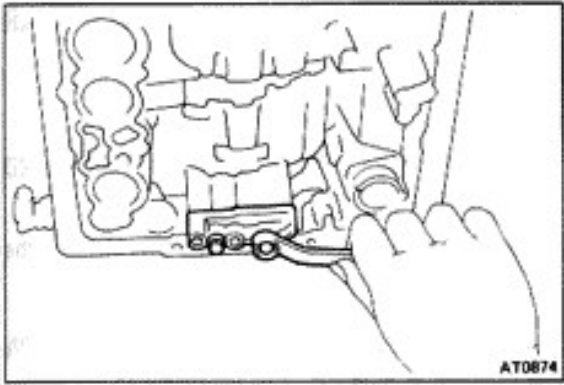

3. REMOVE OUTER PISTON AND REACTION SLEEVE WITH COMPRESSED AIR

(a) Remove the adapter.

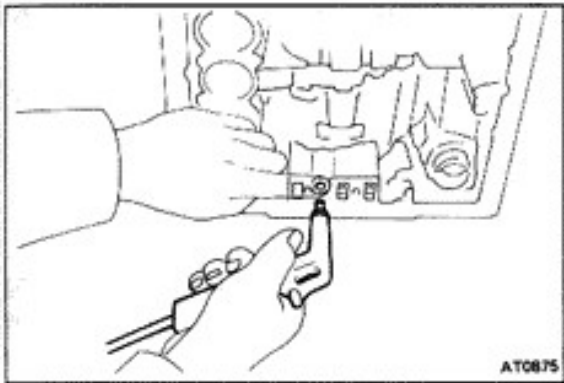

(b) Place several clean shop rags on the piston to catch the piston and sleeve. To pop them out, apply compressed air to the outer and inner piston oil holes.

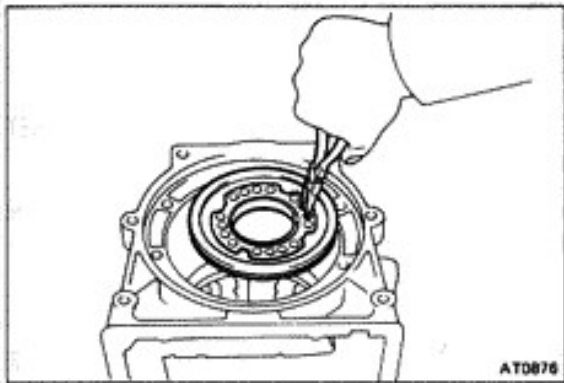

If the piston and sleeve do not pop out with the compressed air:

(c) Using needle-nose pliers, lift out the piston from the case.

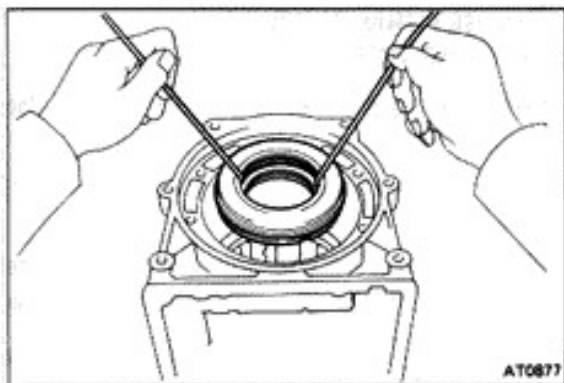

(d) Insert two long hooks behind the reaction sleeve and gradually lift it out of the case.

(e) Using hooks, lift the inner piston out of the case in the same manner.

4. REMOVE O-RINGS FROM OUTER AND INNER PISTONS AND REACTION SLEEVE

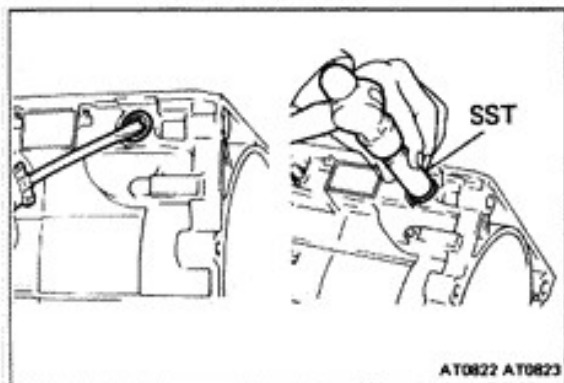

INSPECTION OF CASE COMPONENT GROUP

REPLACEMENT OF MANUAL SHAFT OIL SEALS

(a) Remove the manual shaft oil seals with a screwdriver.

(b) Drive in new left and right oil seals with SST.

SST 09350-20013 (09361-30011)

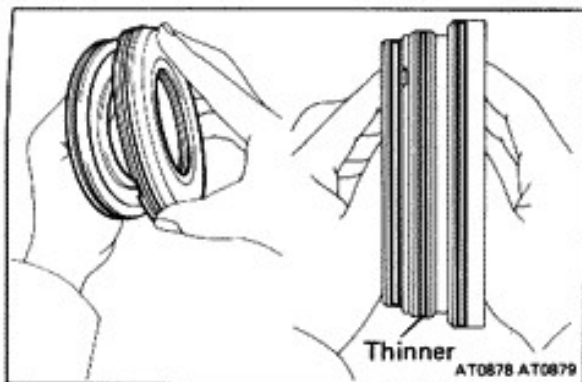

ASSEMBLY OF TRANSMISSION CASE AND REAR BRAKE PISTONS

(See page AT-80)

1. INSTALL NEW O-RINGS ON REACTION SLEEVE AND PISTONS

CAUTION: The thinner O-ring goes on the outside of the reaction sleeve.

2. INSTALL INNER AND OUTER PISTONS IN REACTION SLEEVE

(a) Push the inner piston into the cupped side of the reaction sleeve.

(b) Push the outer piston onto the other side of the reaction sleeve.

3. INSTALL PISTONS AND SLEEVE IN CASE

CAUTION: Be careful not to damage the O-rings.

Hold the assembly with the outer piston upward (spring seats visible), and push the assembly into its bore in the case.

4. INSTALL SST BASE UNDER CASE

SST 09350-20013

5. INSTALL SIXTEEN PISTON RETURN SPRINGS AND SET RETAINER WITH SNAP RING IN PLACE

NOTE: The springs are visible through the cutout in the case, which helps position them more easily.

6. COMPRESS PISTON RETURN SPRINGS TO ALLOW INSTALLATION OF SNAP RING

CAUTION: Do not overtighten the bolt and bend the spring retainer.

(a) Carefully position the spring compressor on the spring retainer.

(b) Gradually and evenly tighten the bolt to compress the springs, being careful not to damage the transmission case with SST.

SST 09350-20013 (09369-20040)

7. INSTALL SNAP RING

(a) Push the ring into place with your fingers. Visually check to make sure it is fully seated and centered by the three lugs on the spring retainer.

(b) Remove the SST.

SST 09350-20013 (09369-20040)

8. KEEP MANUAL VALVE LEVER, PARKING LOCK PAWL AND ACCUMULATOR

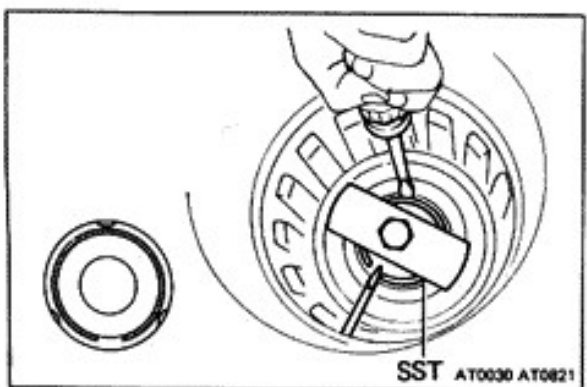
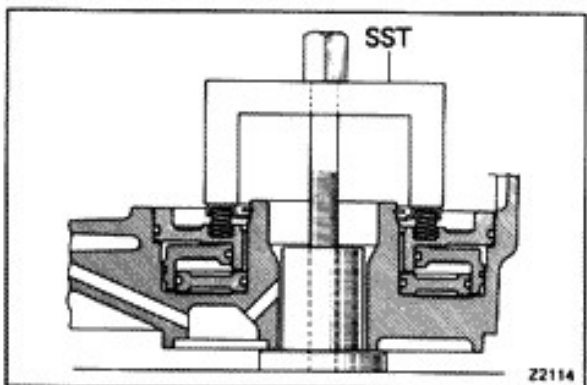
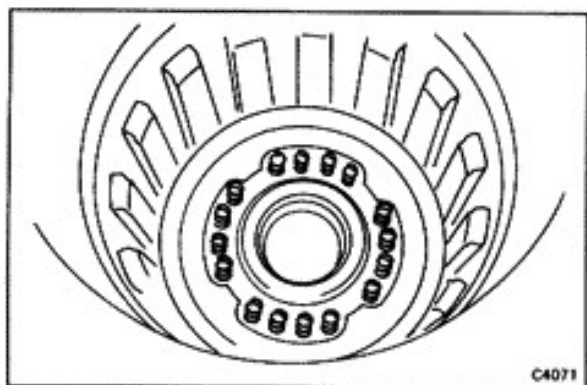
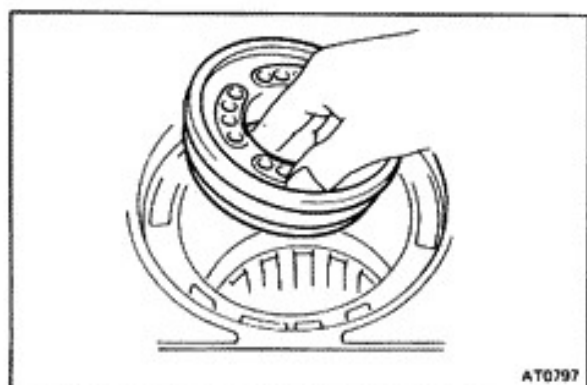

Valve Body

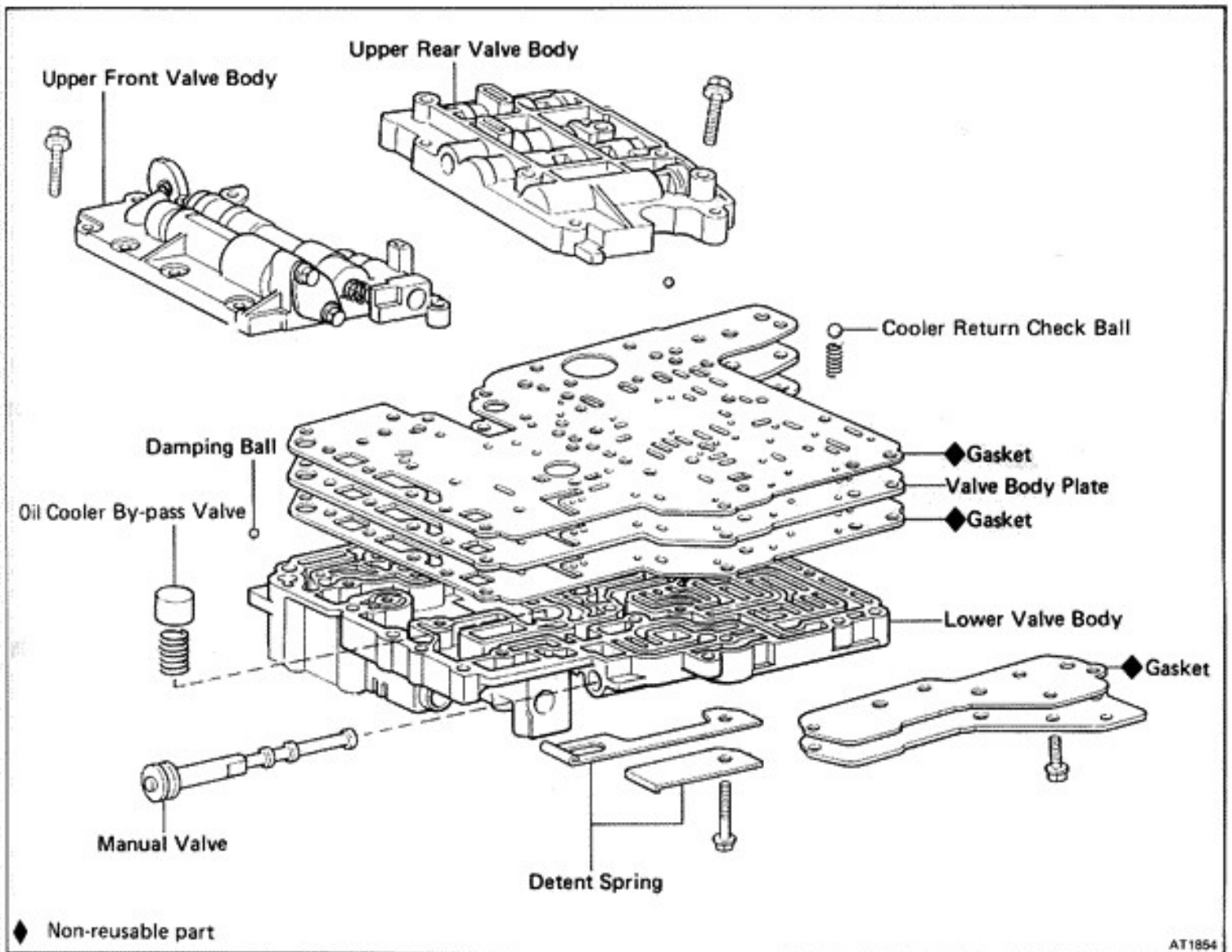

AT1854

(Disassembly of Valve Body)

1. UNBOLT AND REMOVE DETENT SPRING
2. REMOVE MANUAL VALVE

3. TURN ASSEMBLY OVER AND REMOVE NINE BOLTS FROM UPPER FRONT VALVE BODY AND UPPER REAR VALVE BODY

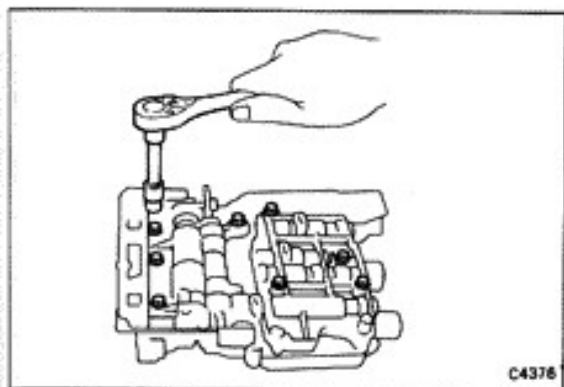
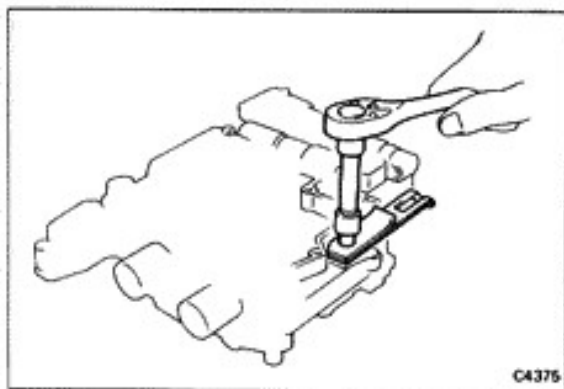

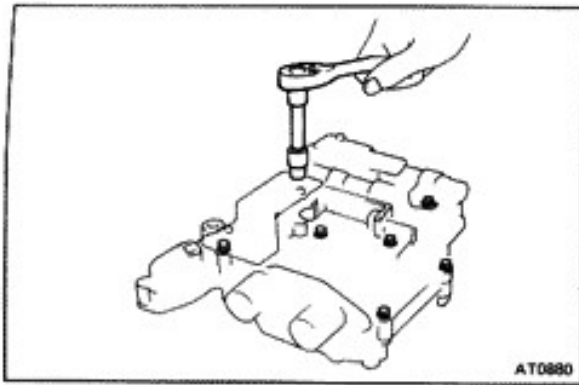

4. **TURN ASSEMBLY OVER AND REMOVE SET BOLTS FROM LOWER VALVE BODY**

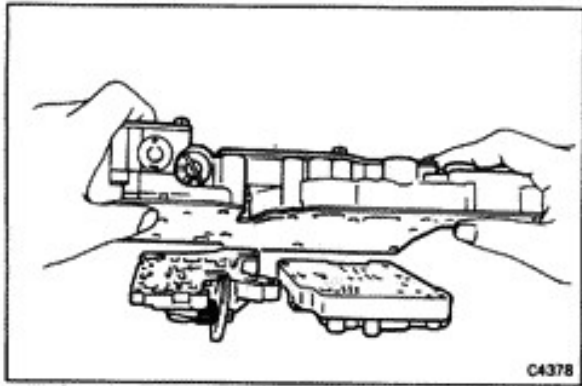

5. **LIFT OFF LOWER VALVE BODY AND PLATE AS SINGLE UNIT**

Hold valve body plate to lower valve body.

NOTE: Be careful that the check valve and balls do not fall out.

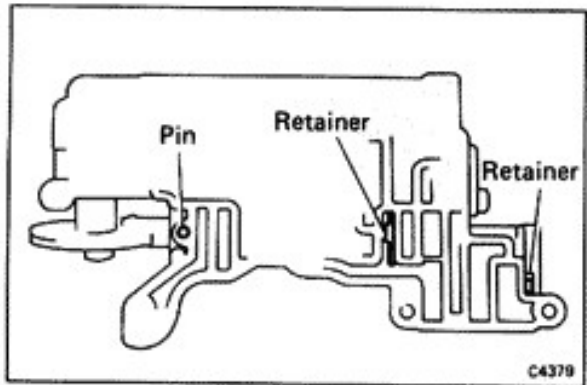

6. **WATCH FOR STEEL BALLS, RETAINERS AND PINS IN VALVE BODY**

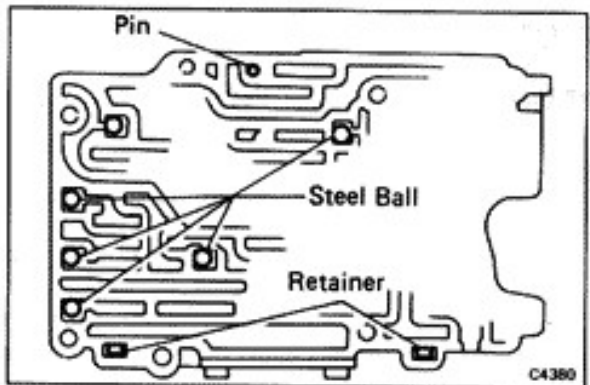

(Lower Valve Body)

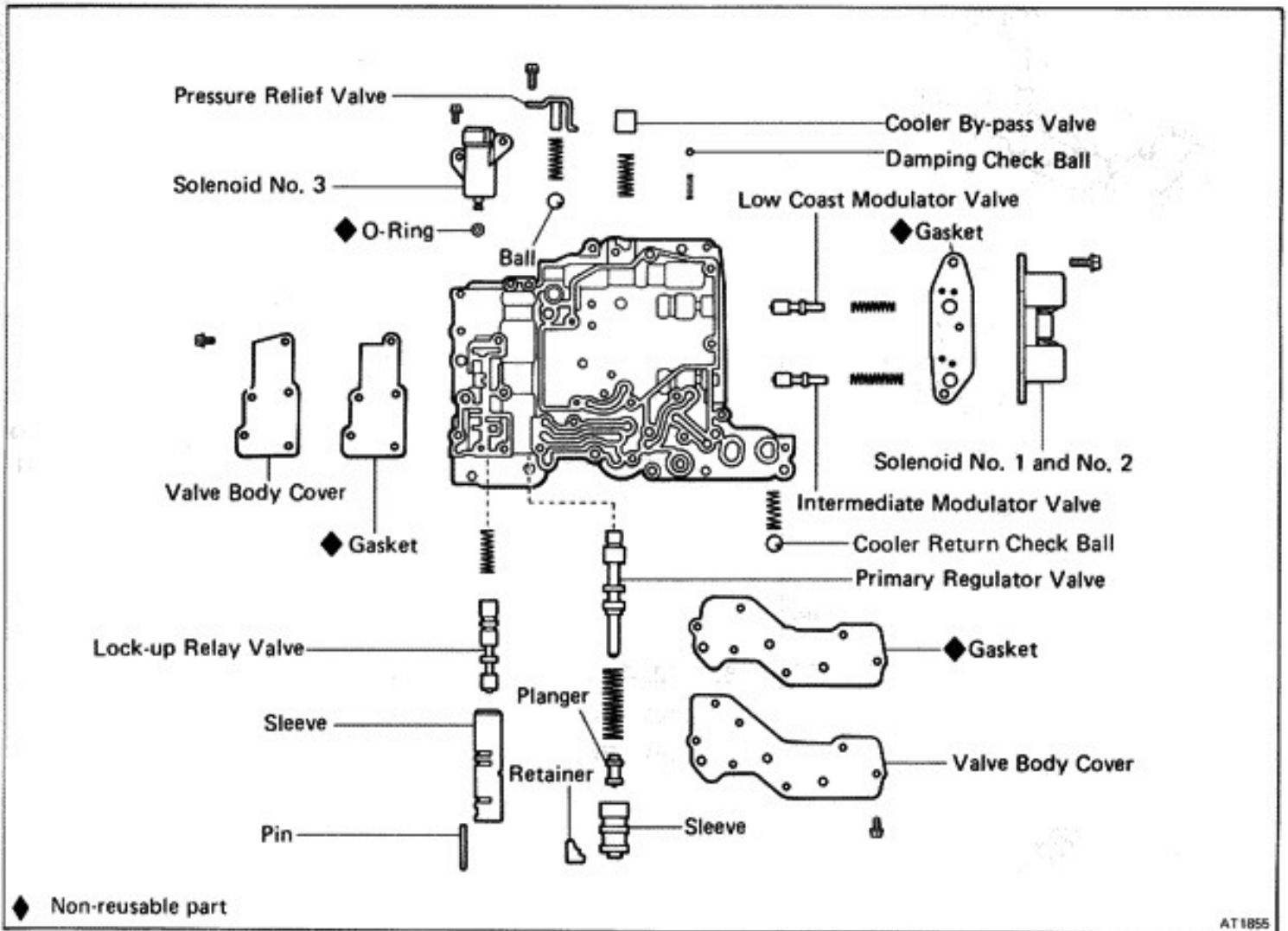

AT1855

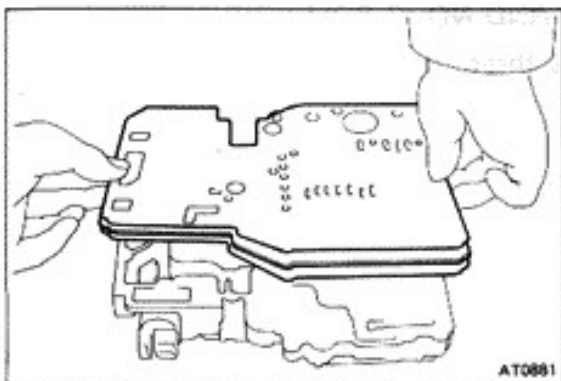

DISASSEMBLY OF LOWER VALVE BODY

1. REMOVE LOWER VALVE BODY PLATE AND GASKETS

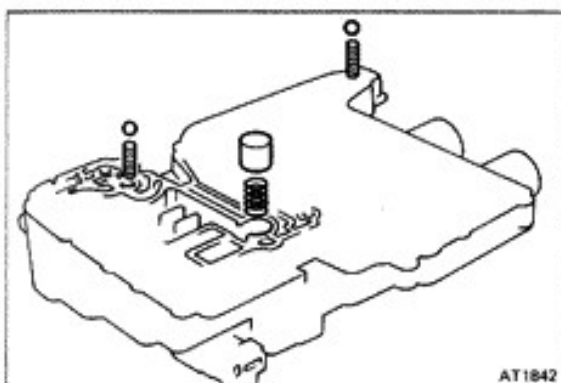

2. REMOVE DAMPING CHECK BALL, COOLER RETURN CHECK BALL, COOLER BY-PASS VALVE AND SPRINGS

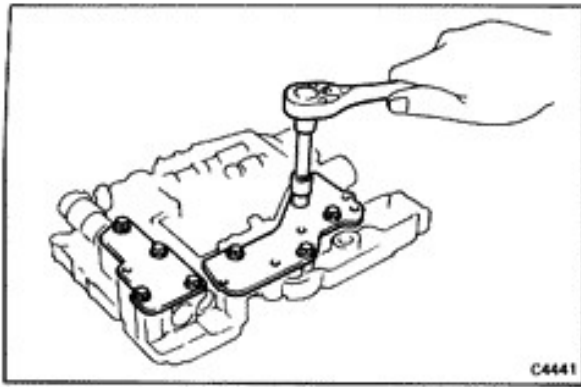

3. **TURN ASSEMBLY OVER, REMOVE SET BOLTS AND REMOVE TWO VALVE BODY COVERS AND GASKETS**

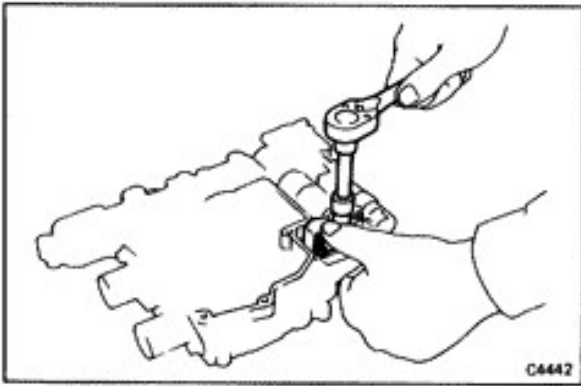

4. **REMOVE PRESSURE RELIEF VALVE**

- (a) Remove the bolt and retainer.
 (b) Remove the spring and steel ball.

CAUTION: Cover the spring with your hand. Slowly remove the bolt, being careful not to pop out the spring.

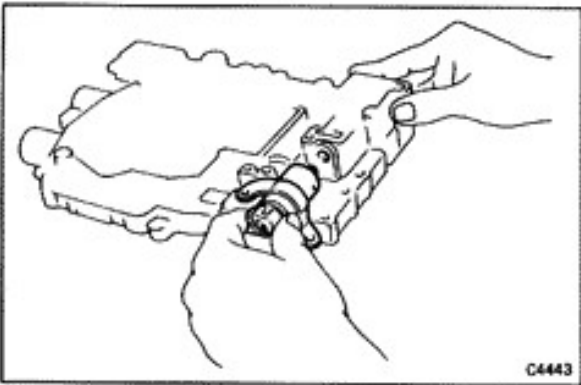

5. **REMOVE NO. 3 SOLENOID**

- (a) Remove the bolt.
 (b) Remove the solenoid from the bore.

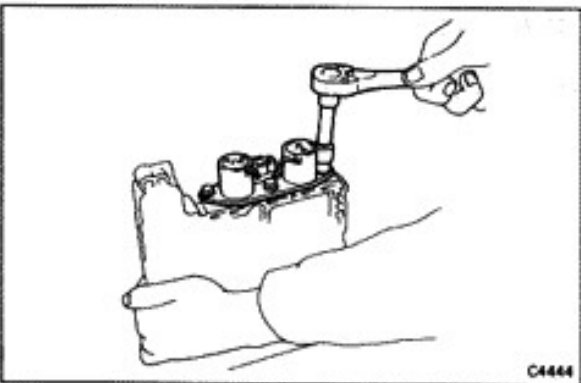

6. **REMOVE NO. 1 AND NO. 2 SOLENOID**

- (a) Remove the three bolts, the solenoid and gasket.

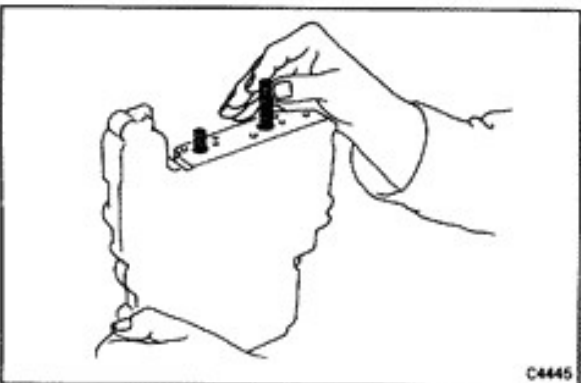

- (b) Remove the two springs from the bore.

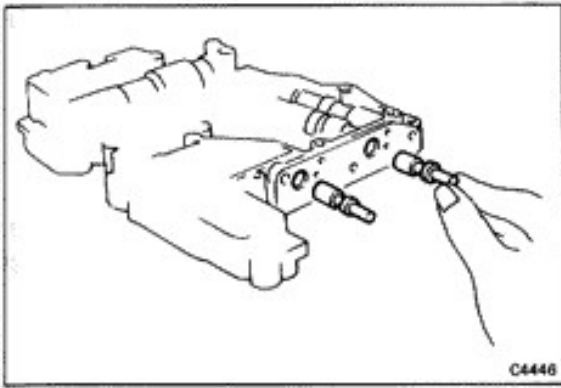

7. REMOVE LOW COAST MODULATOR VALVE AND INTERMEDIATE MODULATOR VALVE

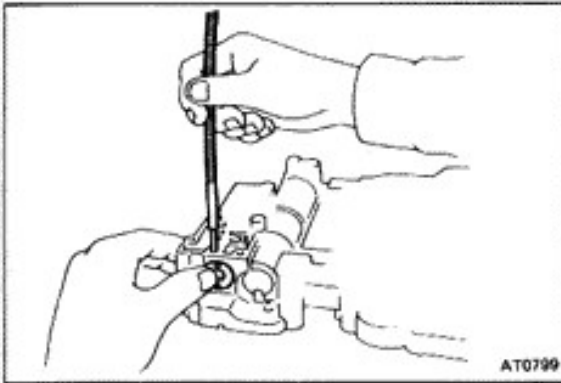

8. REMOVE LOCK-UP RELAY VALVE

(a) Remove the pin by pushing the sleeve.

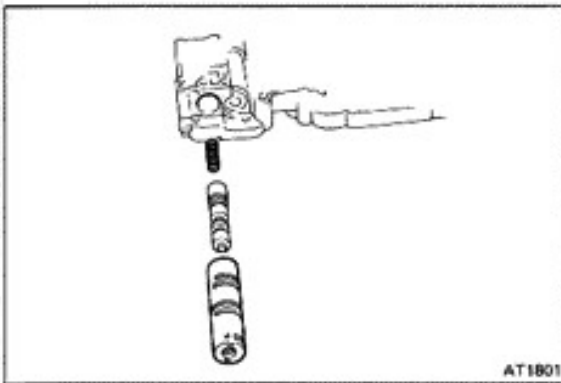

(b) Remove sleeve with lock-up relay valve and spring.

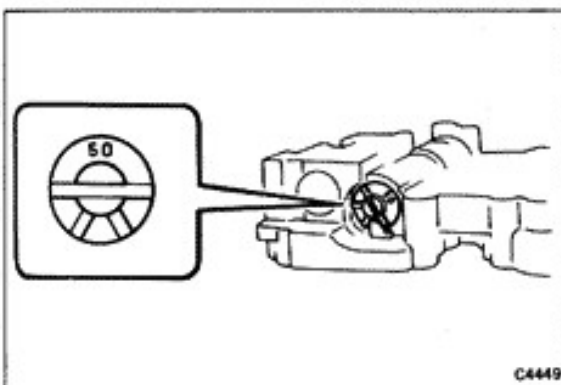

9. REMOVE SPRING RETAINER FROM PRIMARY REGULATOR VALVE

WARNING: Highly compressed spring inside — keep away from face.

(a) Place a mark on the bevel when the retainer is positioned.

NOTE: When reassembling, position the retainer in the same position.

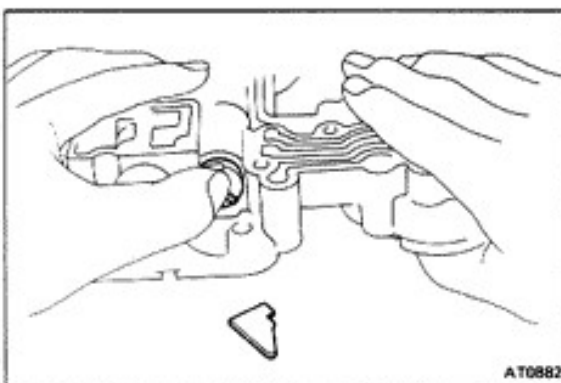

(b) To remove the retainer, hold the valve body face down, and press in on the valve sleeve. The retainer will drop out. Slowly relieve spring tension.

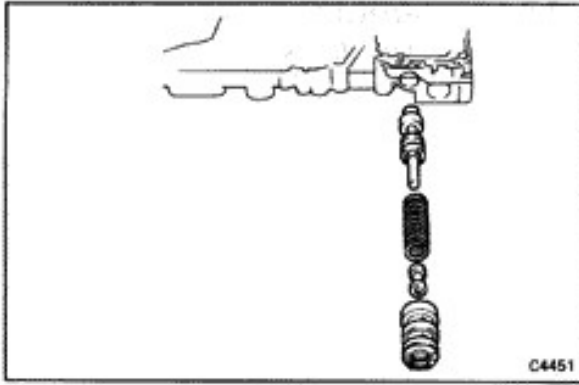

- (c) Remove the sleeve, plunger, spring and primary regulator valve.

INSPECTION OF LOWER VALVE BODY

INSPECT VALVE SPRINGS

Check for damage, squareness, rust and distorted coils. Measure the spring free height and replace if less than that shown below.

| Spring | Free height | mm (in.) | Color |
|----------------------------------|-------------|----------|--------|
| (1) Primary regulator valve | 56.30 | (2.2165) | Blue |
| (2) Low coast modulator valve | 42.35 | (1.6673) | None |
| (3) Intermediate modulator valve | 35.43 | (1.3949) | Red |
| (4) Lock-up relay valve | 32.60 | (1.2835) | Green |
| (5) Oil cooler by-pass valve | 33.32 | (1.3118) | Yellow |
| (6) Pressure relief valve | 32.14 | (1.2654) | None |
| (7) Damping check ball | 20.00 | (0.7874) | None |

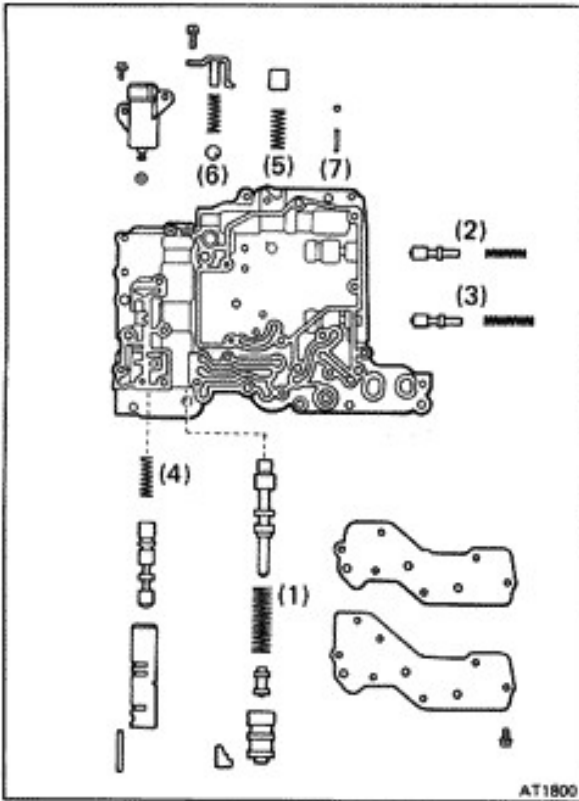

ASSEMBLY OF LOWER VALVE BODY

(See page AT-85)

1. INSERT PRIMARY REGULATOR VALVE AND SPRING

- (a) Set the valve body on the edge and drop in the valve, large end first, and the spring.
- (b) Make sure that the primary regulator valve fits flush with the valve body.

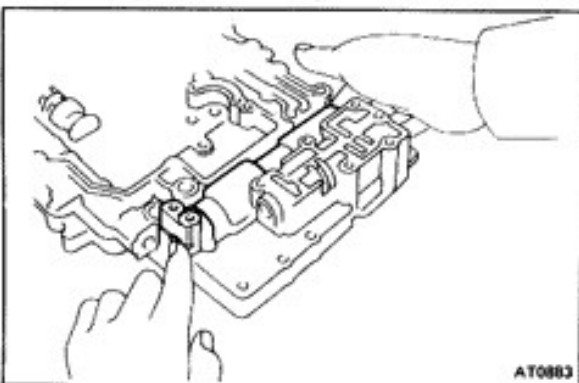
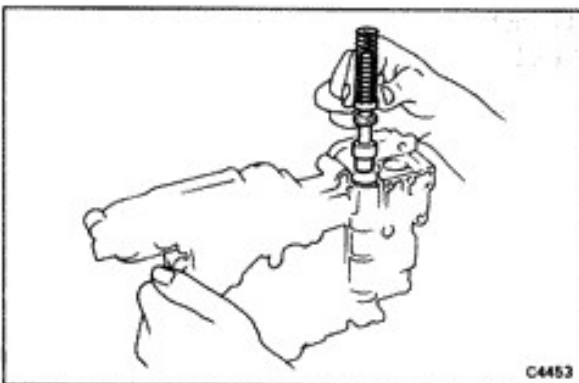

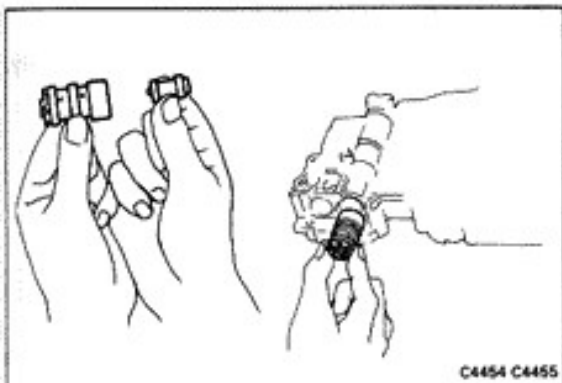

- (c) Insert with the rounded end first. Make sure that it is fully inserted; the plunger should be recessed inside the sleeve.
- (d) Insert the sleeve with the plunger.
- (e) Install the regulator valve sleeve retainer.

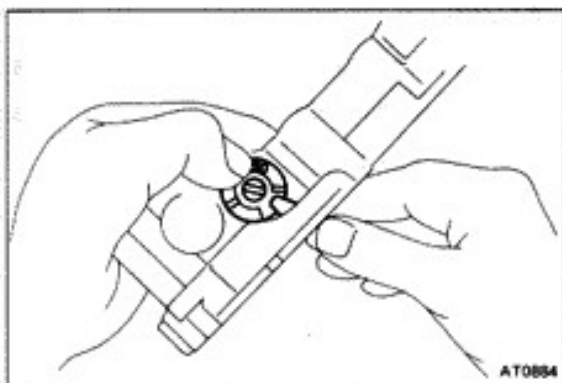

- (f) Install the retainer on the bevel.
- NOTE:** Install the retainer to the same position of the sleeve, as when disassembling.

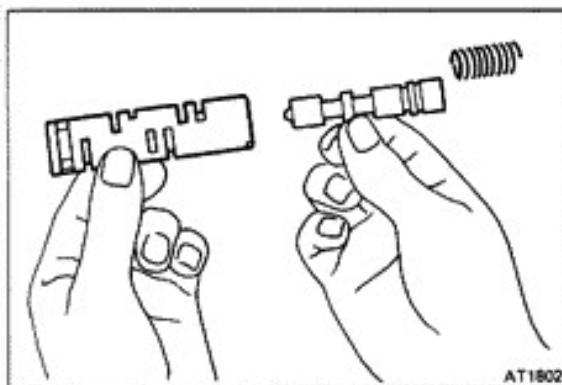

2. INSTALL LOCK-UP RELAY VALVE

- (a) Install the lock-up relay valve into the sleeve.
- (b) Install the spring into the lock-up relay valve.



- (c) Install the lock-up relay valve assembly into the bore.

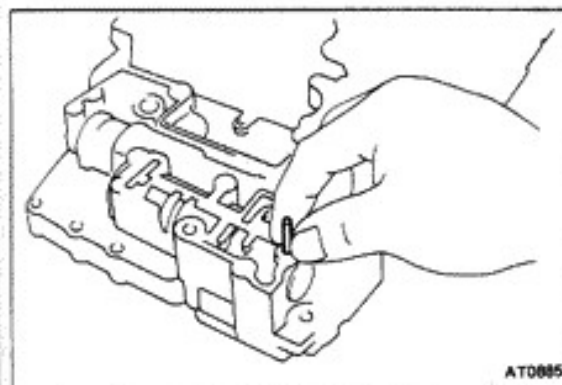

- (d) Install the pin.

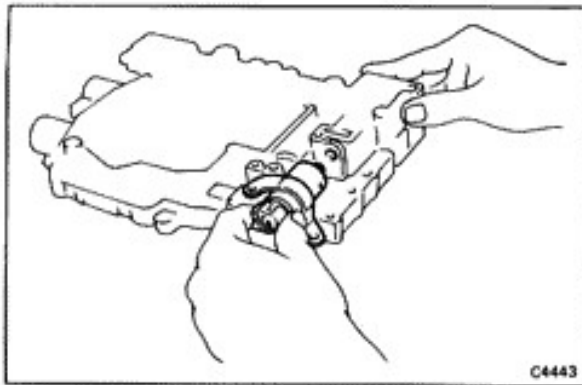

C4443

3. INSTALL NO.3 SOLENOID

- (a) Install the No. 3 solenoid onto the lower valve body.
- (b) Temporarily tighten the bolt.

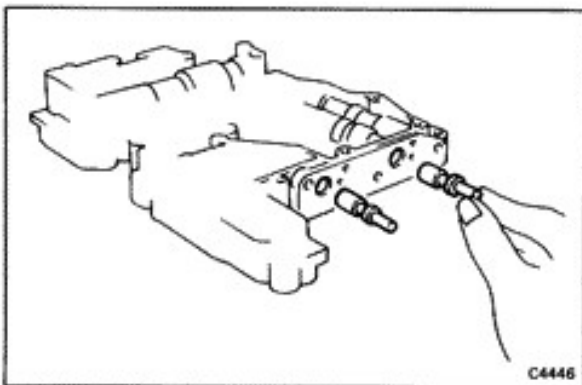

C4446

4. INSTALL TWO VALVES

- (a) Install the low coast modulator valve into the bore.
- (b) Install the intermediate modulator valve into the bore.

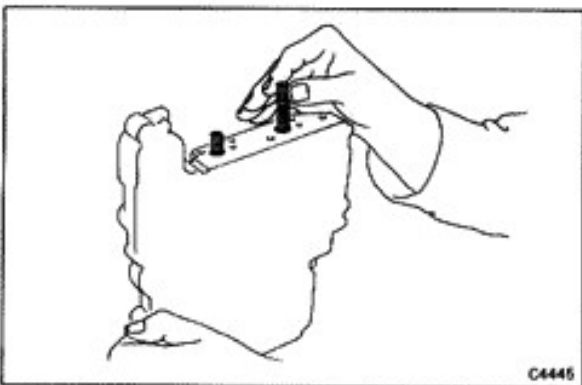

C4445

5. INSTALL TWO VALVE SPRINGS

NOTE: Install the short spring in the right bore.

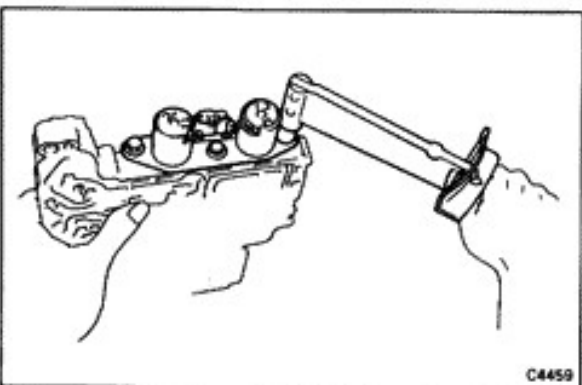

C4459

6. INSTALL NO.1 AND NO.2 SOLENOIDS

Install the solenoid over the gasket.
Tighten the three bolts.

Torque: 100 kg-cm (7 ft-lb, 10 N·m)

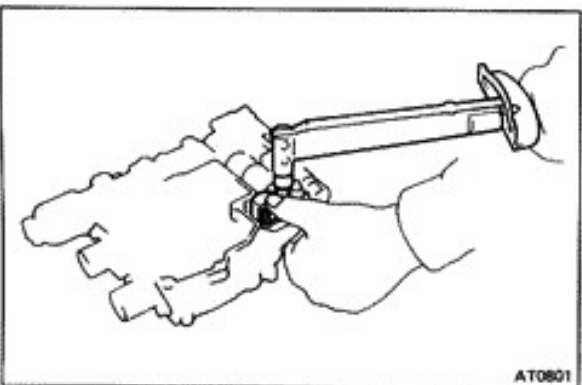

AT0801

7. INSTALL PRESSURE RELIEF VALVE

- (a) Place the steel ball and spring onto the body.
- (b) Install the retainer.

Torque: 55 kg-cm (48 in.-lb, 5.4 N·m)

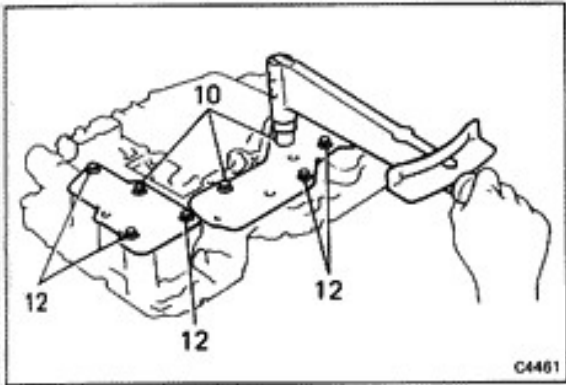
**8. INSTALL TWO VALVE BODY COVERS**

NOTE: Use the wave washer for the smaller cover.

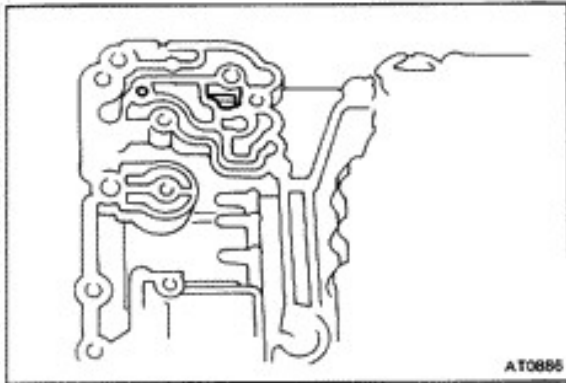
**9. CHECK RETAINERS AND LOCATING PINS**

Make sure that the retainers and pins are installed correctly.

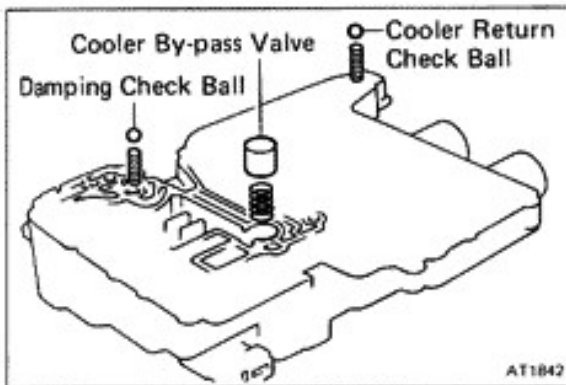
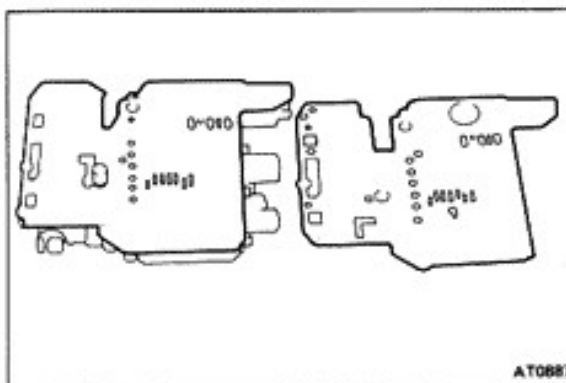
**10. INSTALL SPRINGS, DAMPING CHECK BALL, COOLER RETURN CHECK BALL AND COOLER BY-PASS CHECK VALVE****11. INSTALL LOWER VALVE BODY GASKET**

Note that the two gaskets are not interchangeable. The gasket must lay flat on the valve body.

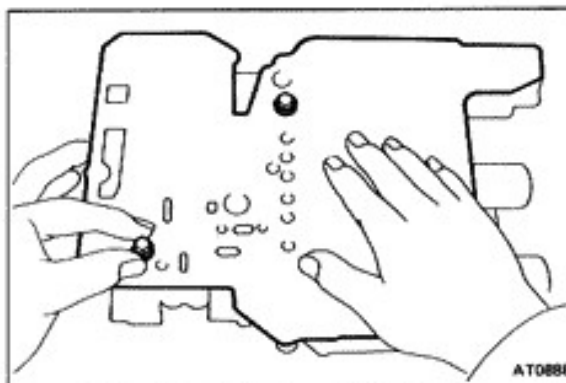
**12. INSTALL LOWER VALVE BODY PLATE**

Set the plate into place. Temporarily install two the short bolts finger tight to compress the plate against the spring-loaded check valve.

NOTE: Use the oil strainer bolts.

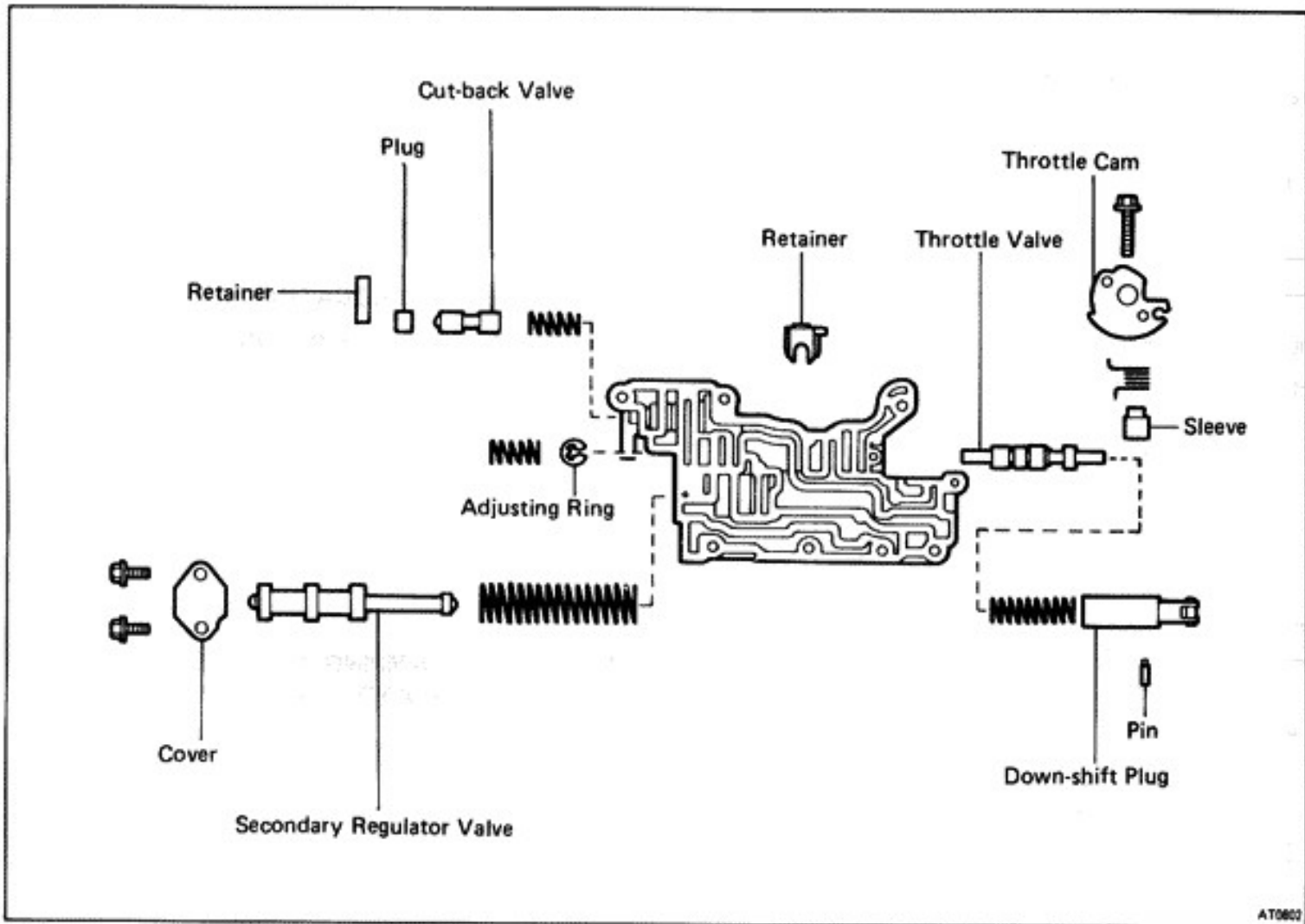
(Upper Front Valve Body)

AT0803

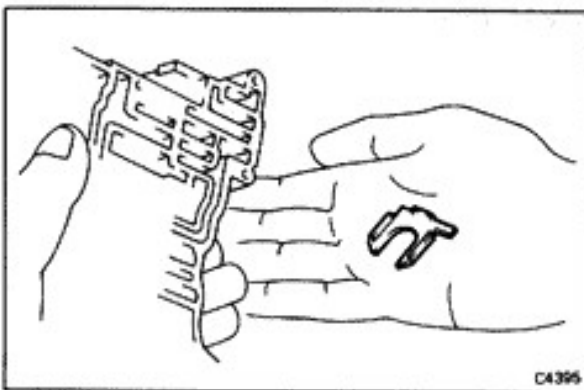

C4395

DISASSEMBLY OF UPPER FRONT VALVE BODY

1. REMOVE THROTTLE VALVE RETAINER

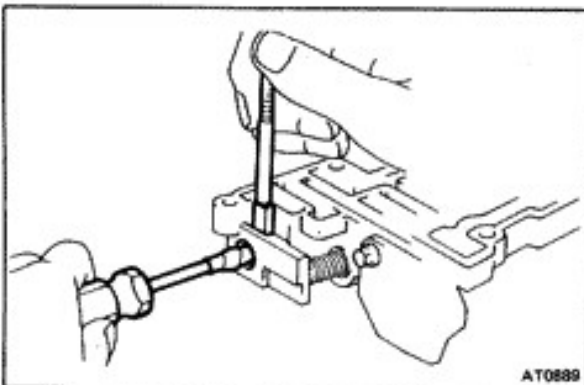

AT0889

2. REMOVE CUT-BACK PLUG RETAINER

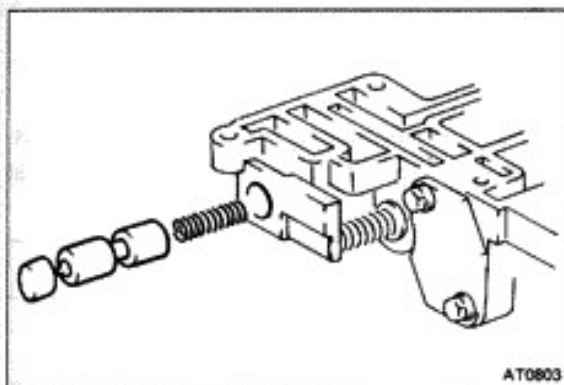

3. REMOVE PLUG AND CUT-BACK VALVE

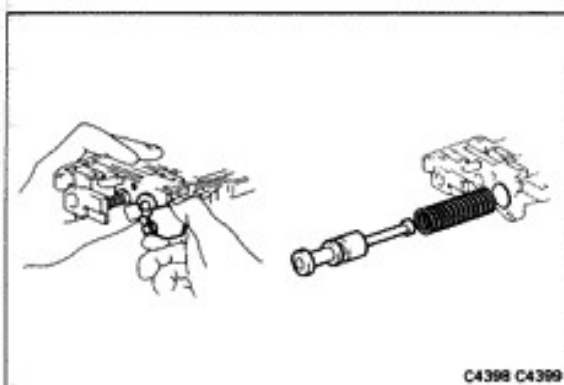

4. REMOVE SECONDARY REGULATOR VALVE AND SPRING

- (a) Remove one bolt from the plate over the valve and loosen the other one. Slowly rotate the plate to uncover the valve.

WARNING: Valve is spring-loaded.

- (b) Remove the valve and spring. Keep the spring with the valve.
- (c) Remove the other bolt and remove the cover plate.

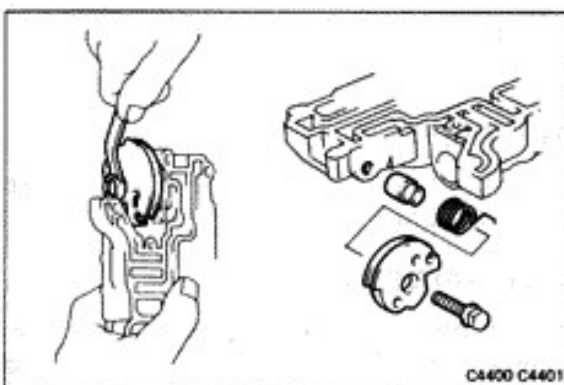

5. REMOVE THROTTLE CAM

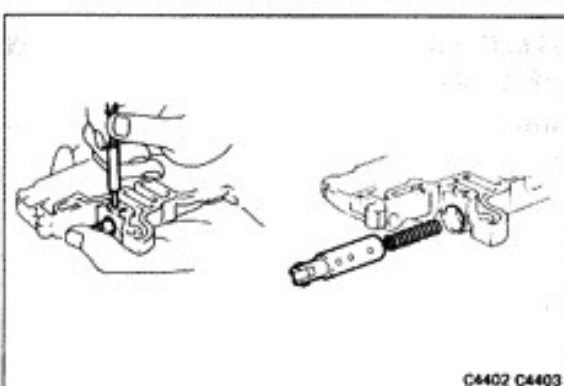

6. REMOVE DOWN-SHIFT PLUG AND SPRING

- (a) Remove the pin by pushing the down-shift plug.
- (b) Remove the down-shift plug with the sleeve and spring.

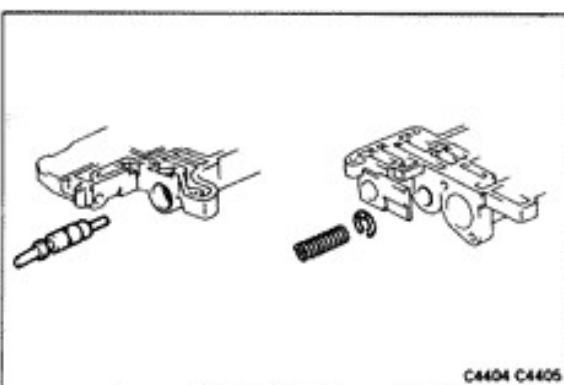

7. REMOVE THROTTLE VALVE AND SPRING

8. REMOVE ADJUSTING RINGS

Note the number of adjusting rings installed.

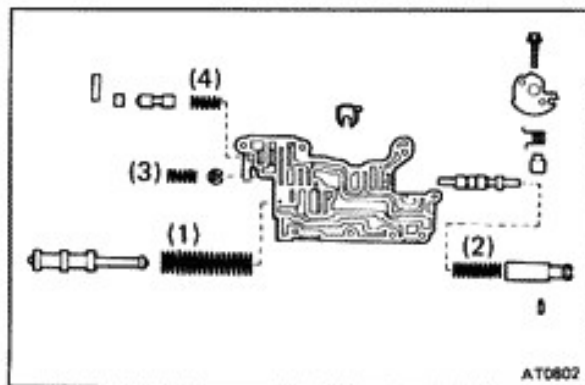

INSPECTION OF UPPER FRONT VALVE BODY

INSPECT VALVE SPRINGS

Check for damage, squareness, rust and collapsed coils. Measure the spring free height and replace if less than that shown below.

| Spring | Free height mm (in.) | Color |
|-------------------------------|----------------------|-------|
| (1) Secondary regulator valve | 71.27 (2.8059) | Green |
| (2) Down-shift plug | 39.55 (1.5571) | Green |
| (3) Throttle valve | 19.24 (0.7575) | None |
| (4) Cut-back valve | 23.00 (0.9055) | Green |

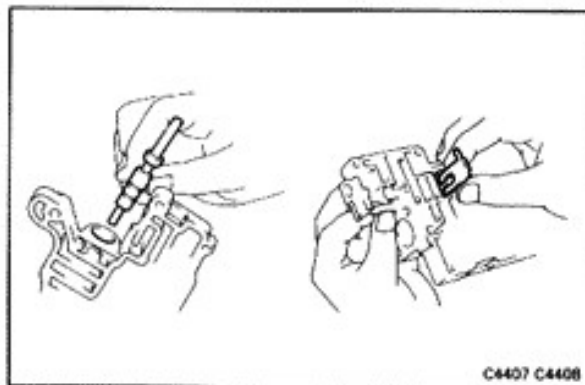

ASSEMBLY OF UPPER FRONT VALVE BODY

(See page AT-92)

1. INSERT THROTTLE VALVE

Note arrangement in the figure. Make sure that the valve is inserted fully into the bore.

2. INSTALL THROTTLE VALVE RETAINER

Coat the retainer with petroleum jelly to keep it in place. Note position of tabs in the figure. Slip the retainer into place in the valve body.

3. INSTALL ADJUSTING RINGS AND SMALL SPRING ON THROTTLE VALVE SHAFT

- Install the same number of adjusting rings as were removed during disassembly.
- Slip the spring over the end of the valve shaft. Compress and slide into place.

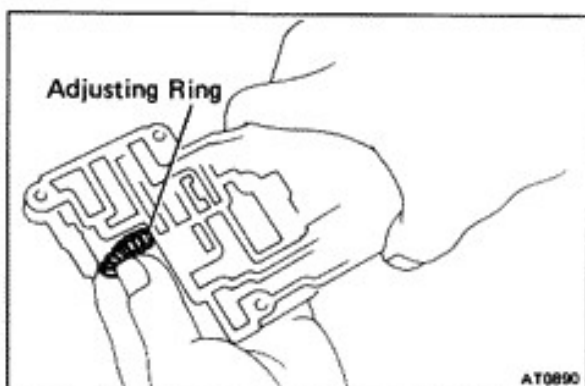

4. INSERT SPRING AND DOWN-SHIFT PLUG

- Push the down-shift plug into the bore.
- Coat the pin with petroleum jelly and install it to hold the sleeve.

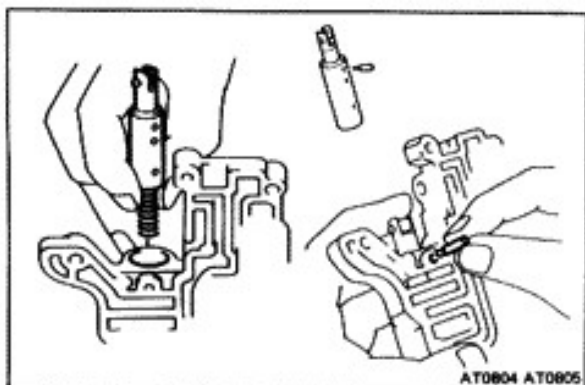

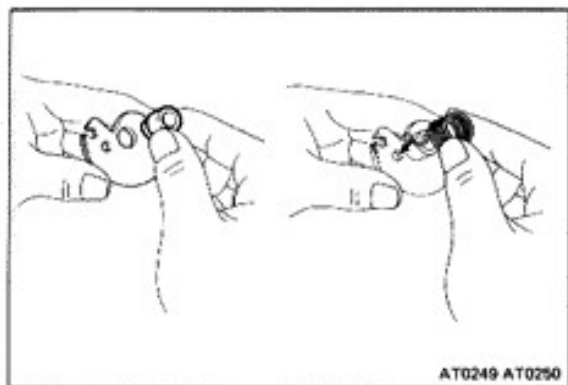

5. ASSEMBLE THROTTLE CAM

- (a) Insert the sleeve through one side of the cam.
- (b) Install the spring with the hook through the hole in the cam.

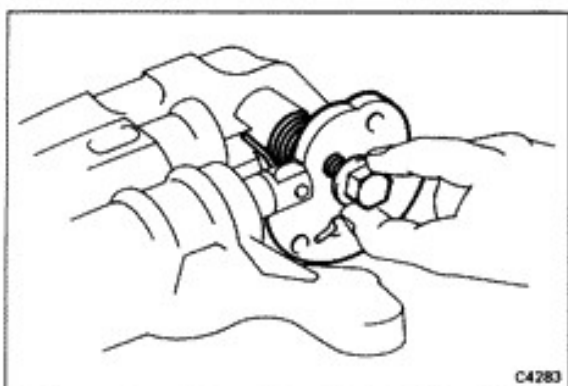

6. INSTALL CAM ASSEMBLY ON UPPER FRONT VALVE BODY

Check the position of the spring ends with the figure. Tighten the bolt.

Torque: 75 kg-cm (65 in.-lb, 7.4 N·m)

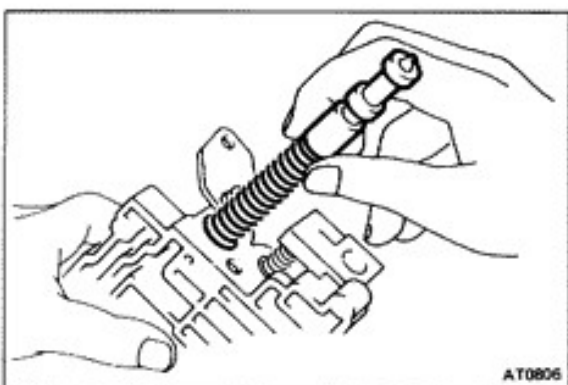

7. INSTALL SECONDARY REGULATOR VALVE

- (a) Partially install the cover plate and insert the spring and secondary regulator valve.

- (b) Compress the spring and swing the cover plate into place.

- (c) Install the second bolt in the cover plate and tighten both bolts.

Torque: 55 kg-cm (48 in.-lb, 5.4 N·m)

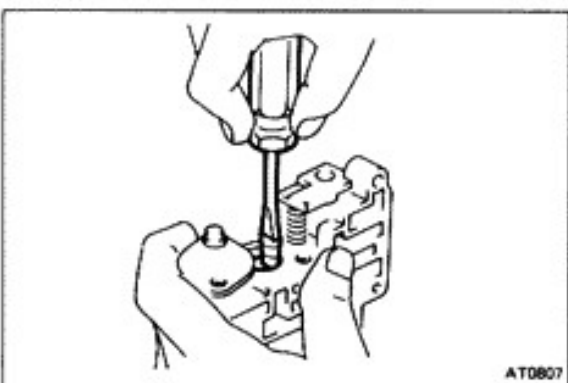

8. INSERT SPRING AND CUT-BACK VALVE

Install the valve with smaller end first.

9. INSTALL PLUG AND VALVE RETAINER

Coat the retainer with petroleum jelly to keep it in place.

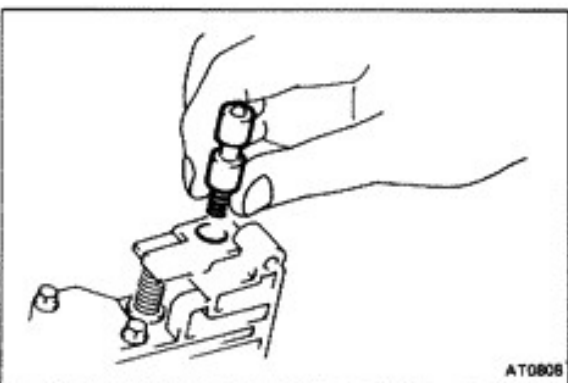

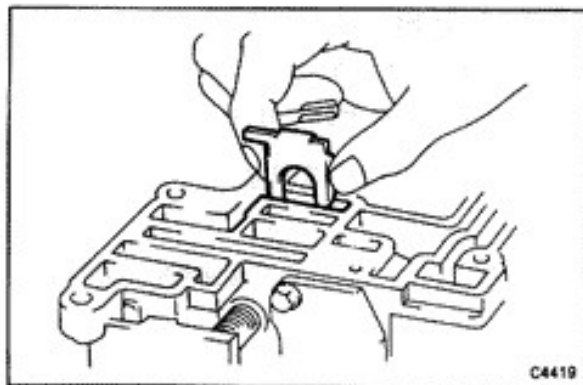
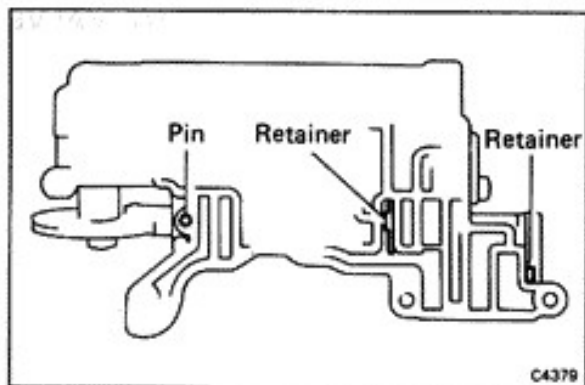
10. INSTALL THROTTLE VALVE RETAINER**11. MAKE SURE THAT SLEEVE IS HELD BY PIN**

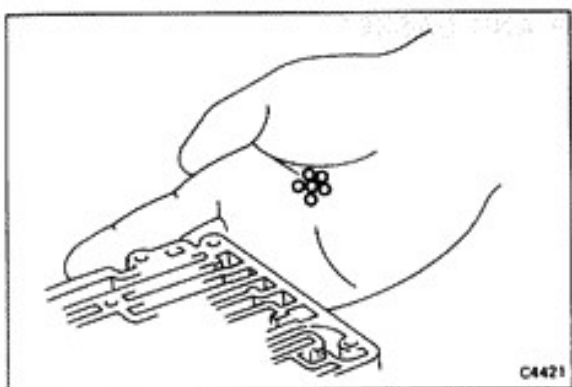
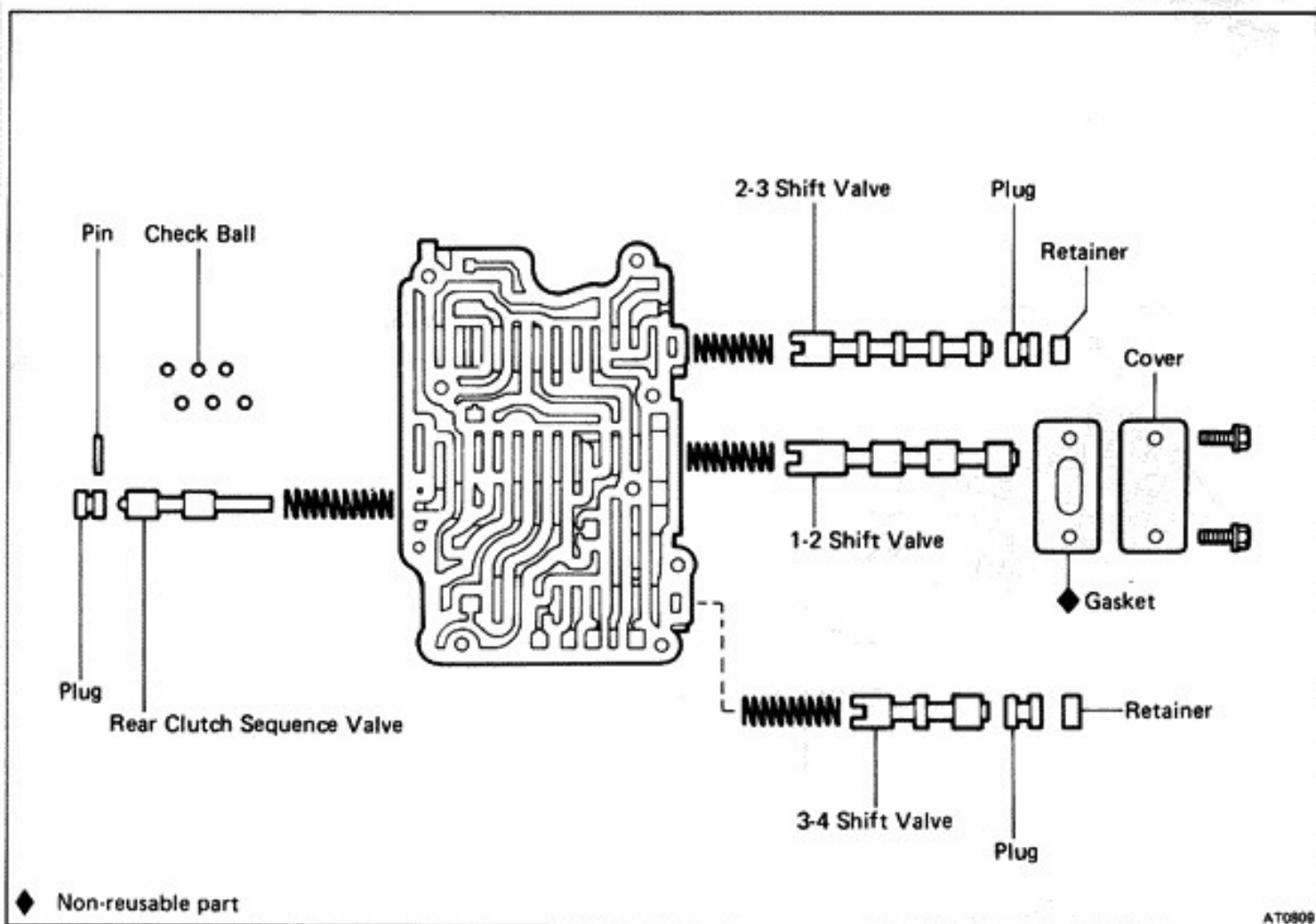
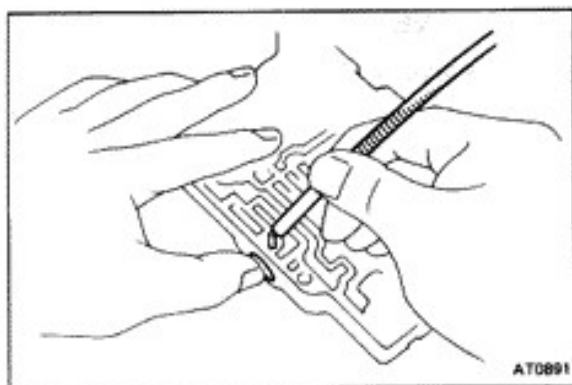
(Upper Rear Valve Body)**DISASSEMBLY OF UPPER REAR VALVE BODY****1. REMOVE SIX CHECK BALLS****2. REMOVE REAR CLUTCH SEQUENCE VALVE**

- (a) Remove the pin with a magnetic finger by pushing on the plug. Then remove the plug.

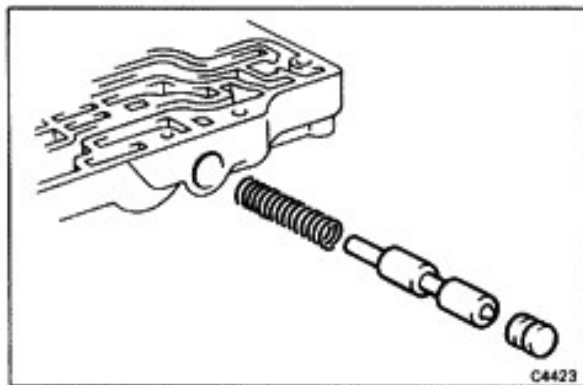

- (b) Remove the rear clutch sequence valve and spring.

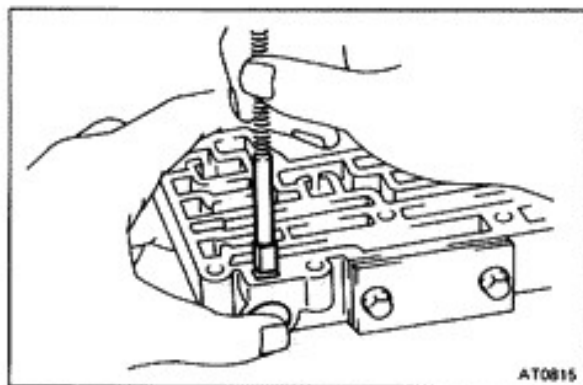

3. REMOVE 3-4 SHIFT VALVE

- (a) Push the plug, remove the retainer with a magnetic finger.

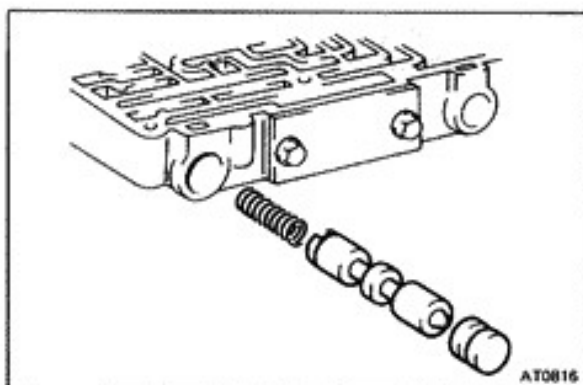

- (b) Remove the plug, valve and spring.

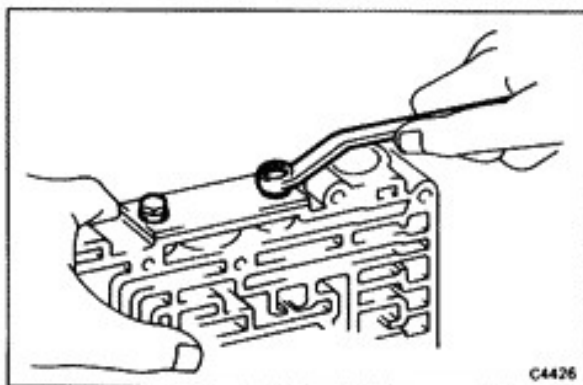

4. REMOVE COVER AND GASKET

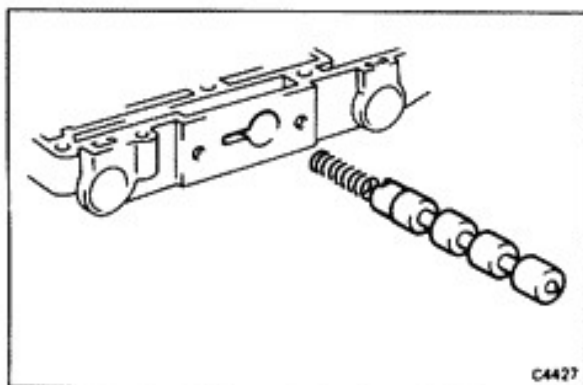

5. REMOVE 1-2 SHIFT VALVE

- Remove the 1-2 shift valve and spring.

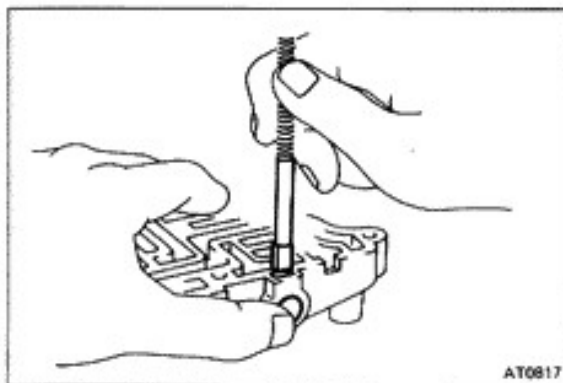

6. REMOVE 2-3 SHIFT VALVE

(a) Push the plug, remove the retainer with a magnetic finger.

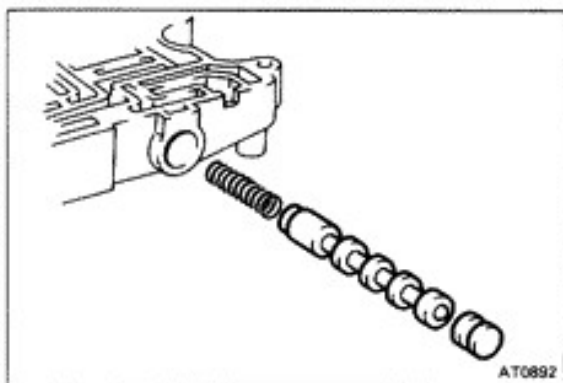

(b) Remove the plug, 2-3 shift valve and spring.

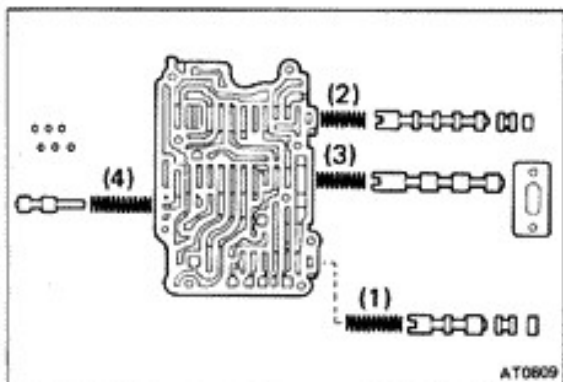

INSPECTION OF UPPER REAR VALVE BODY

INSPECT VALVE SPRINGS

Check for damage, squareness, rust and collapsed coils. Measure the spring free height and replace if less than that shown below.

| Spring | Free height mm (in.) | Color |
|--------------------------------|----------------------|-------|
| (1) 3-4 Shift valve | 29.15 (1.1476) | Blue |
| (2) 2-3 Shift valve | 29.15 (1.1476) | Blue |
| (3) 1-2 Shift valve | 29.15 (1.1476) | Blue |
| (4) Rear clutch sequence valve | 37.55 (1.4783) | None |

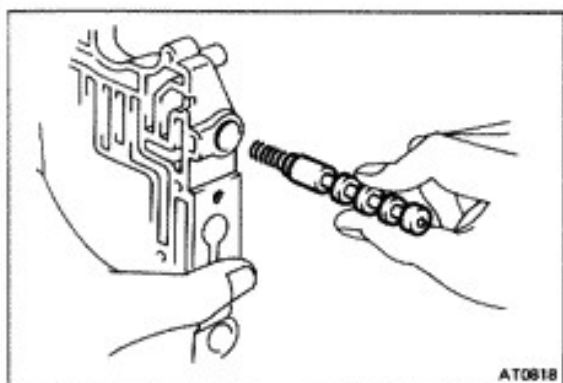

ASSEMBLY OF UPPER REAR VALVE BODY

(See page AT-97)

1. INSTALL 3-4 SHIFT VALVE

(a) Install the 3-4 shift valve and spring.

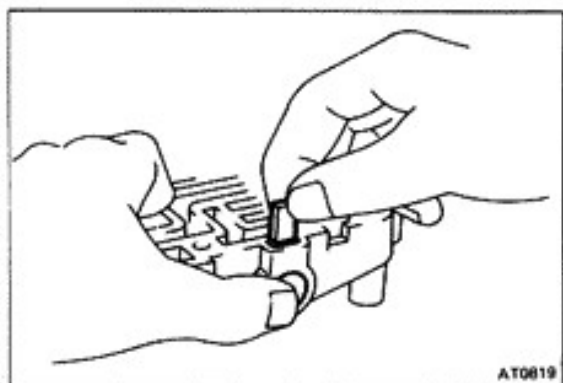

(b) Install the plug into the bore. Coat the retainer with petroleum jelly and install it.

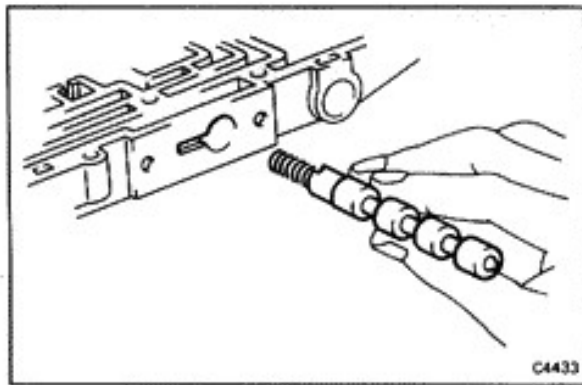

2. INSTALL 1-2 SHIFT VALVE

(a) Install the 1-2 shift valve and spring.

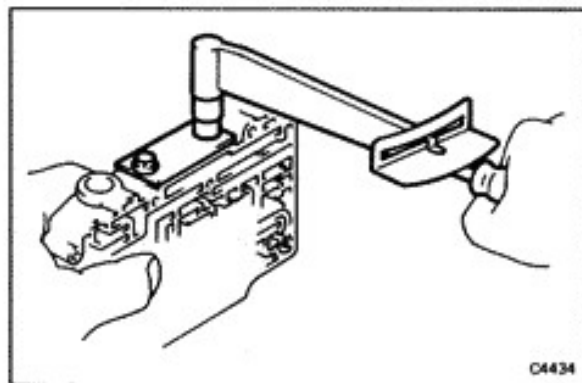

(b) Install the plate over the gasket.

Torque: 55 kg-cm (48 in.-lb, 5.4 N·m)

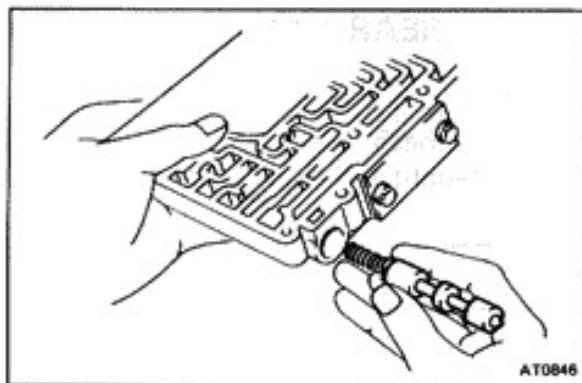

3. INSTALL 2-3 SHIFT VALVE

(a) Install the 2-3 shift valve and spring.

(b) Install the plug into the bore.

(c) Coat the retainer with petroleum jelly and install it.

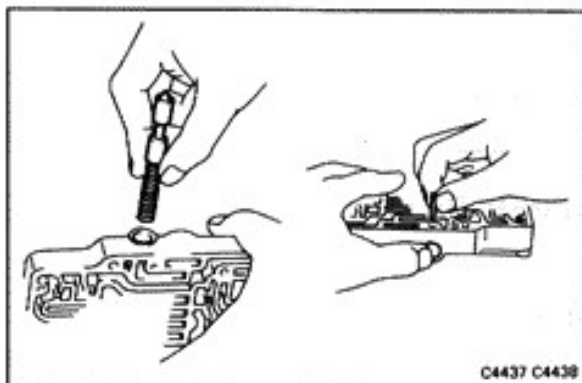

4. INSERT REAR CLUTCH SEQUENCE VALVE

(a) Install the valve spring, and the valve.

(b) Install the plug into the bore.

(c) Coat the pin with petroleum jelly and install it.

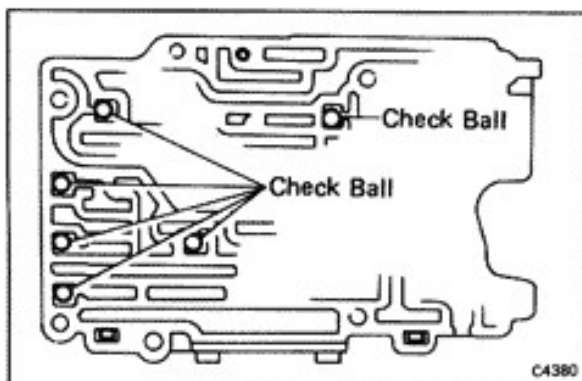

5. INSTALL CHECK BALLS AS SHOWN

Install the six steel balls in the position shown in the figure.

(Assembly of Valve Body)

- 1. POSITION NEW GASKET ON UPPER REAR VALVE BODY**

Align a new gasket at each bolt hole.

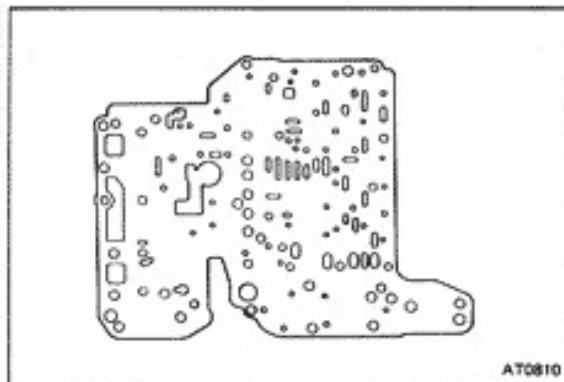

- 2. PLACE LOWER VALVE BODY WITH PLATE GASKET ON TOP OF UPPER REAR VALVE BODY**

Align each bolt hole in the valve body and gasket.

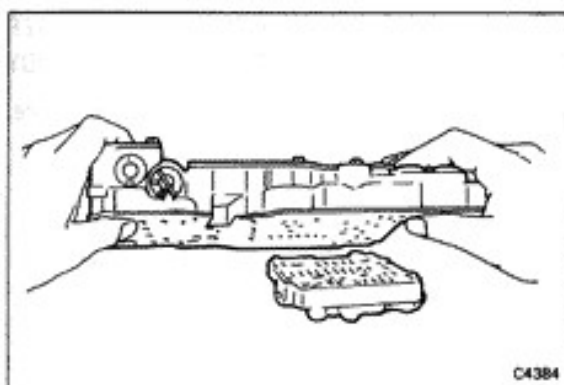

- 3. INSTALL AND FINGER TIGHTEN THREE BOLTS IN LOWER VALVE BODY TO SECURE UPPER REAR VALVE BODY**

NOTE: Each bolt length (mm) is indicated in the figure.

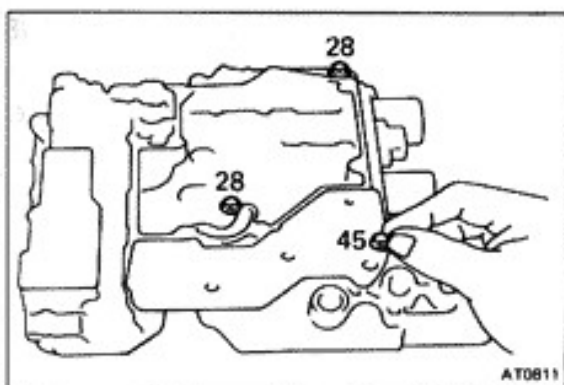

- 4. TURN ASSEMBLY OVER, CHECK GASKET ALIGNMENT AND FINGER TIGHTEN FOUR BOLTS IN UPPER REAR VALVE BODY**

NOTE: Each bolt length (mm) is indicated in the figure.

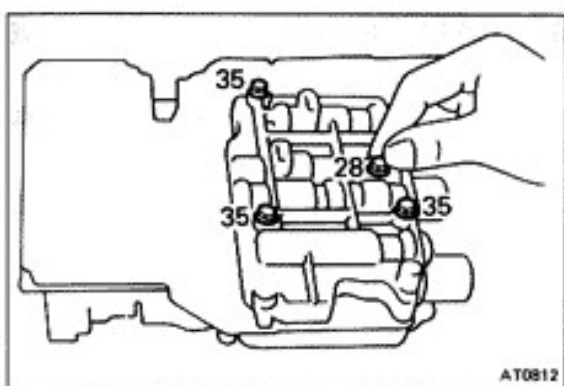

- 5. REMOVE TEMPORARY BOLTS FROM PLATE**

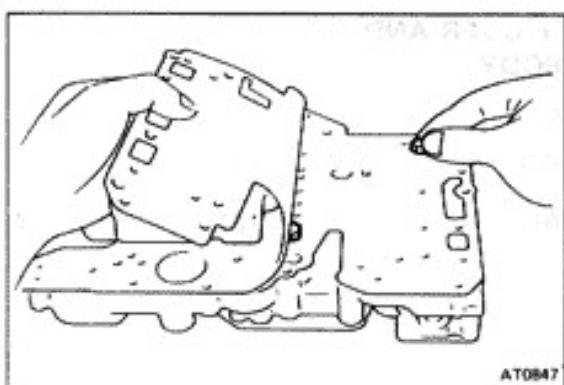

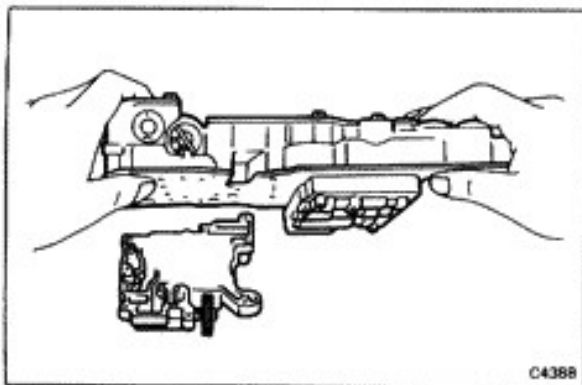

6. **PLACE LOWER AND UPPER REAR VALVE BODY ASSEMBLY ON TOP OF UPPER FRONT VALVE BODY**

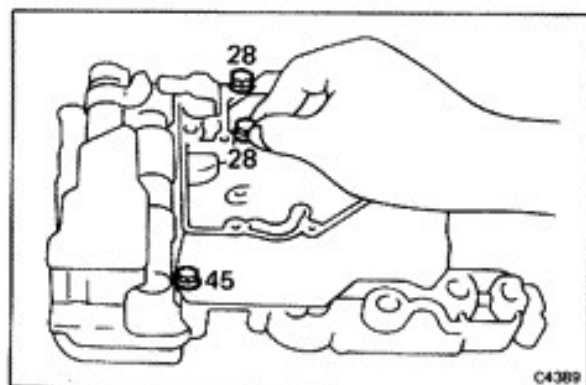

7. **INSTALL AND FINGER TIGHTEN SET BOLTS IN LOWER VALVE BODY TO SECURE UPPER FRONT VALVE BODY**
NOTE: Each bolt length (mm) is indicated in the figure.

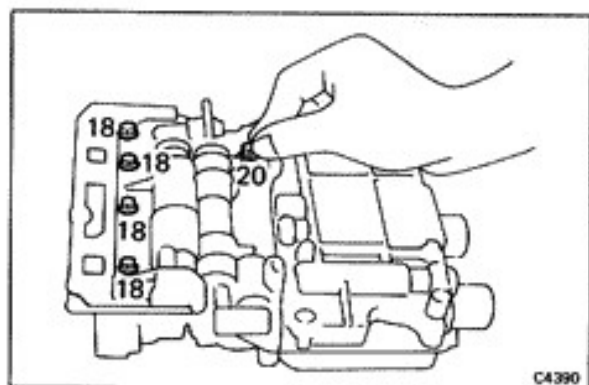

8. **TURN ASSEMBLY OVER AND FINGER TIGHTEN FIVE BOLTS IN UPPER FRONT VALVE BODY**
NOTE: Each bolt length (mm) is indicated in the figure.

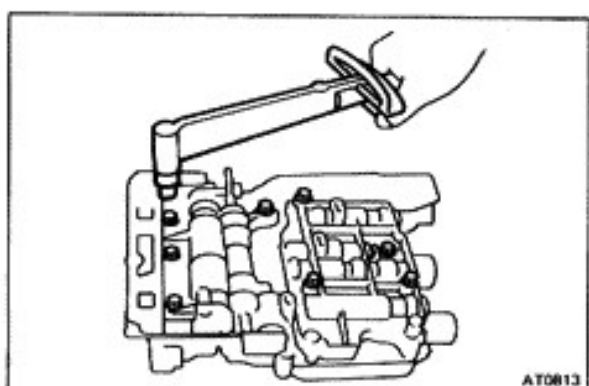

9. **TIGHTEN BOLTS IN UPPER FRONT AND REAR VALVE BODIES**
Recheck the alignment of the gaskets. Tighten the bolts.
Torque: 55 kg-cm (48 in.-lb, 5.4 N·m)

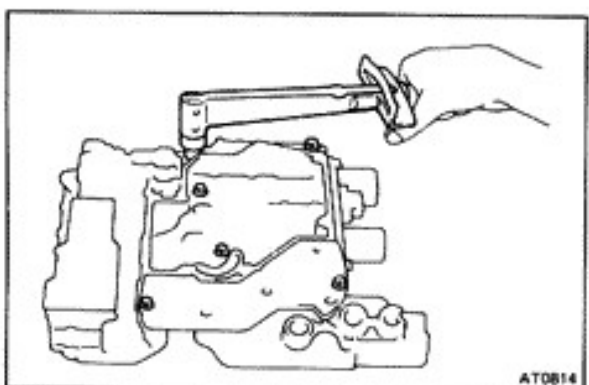

10. **TURN ASSEMBLY OVER AND TIGHTEN BOLTS IN LOWER VALVE BODY**
Tighten the bolts.
Torque: 55 kg-cm (48 in.-lb, 5.4 N·m)
11. **INSTALL MANUAL VALVE INTO LOWER VALVE BODY**

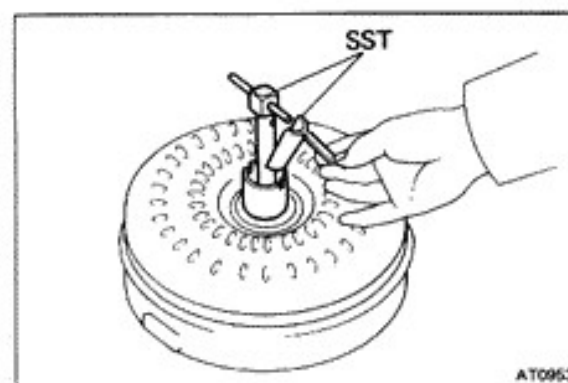
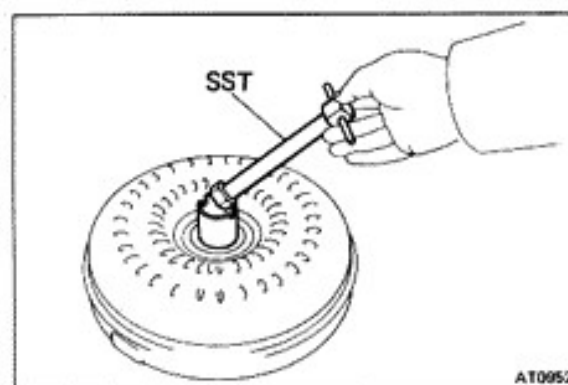
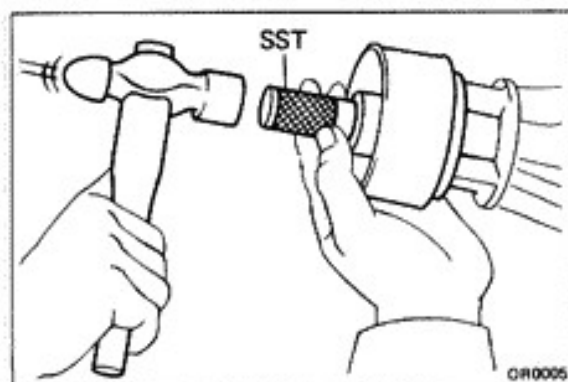
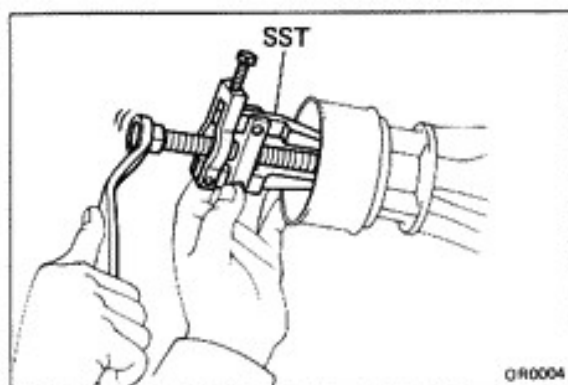
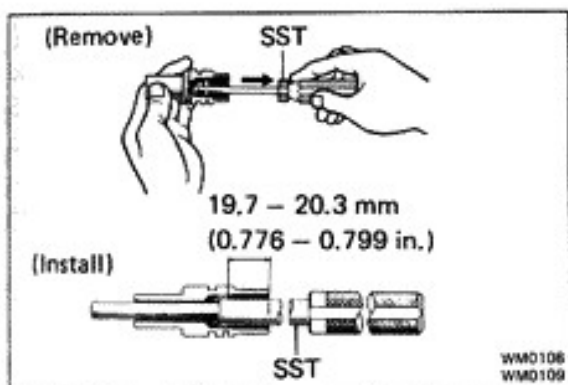

Extension Housing

INSPECTION OF SPEEDOMETER GEAR AND EXTENSION HOUSING

1. IF NECESSARY, REPLACE SPEEDOMETER GEAR OIL SEAL
 - (a) Using SST, remove the oil seal.
SST 09921-00010
 - (b) Using SST, install the new oil seal.
SST 09201-60011
2. IF NECESSARY, REPLACE OIL SEAL AND DUST SEAL
 - (a) Using SST, remove the oil seal.
SST 09308-10010
 - (b) Using SST, drive in a new oil seal and dust seal.
SST 09325-20010

Torque Converter

CLEAN TORQUE CONVERTER

If the transmission is contaminated, the torque converter and transmission cooler should be thoroughly flushed, using Toyota Transmission Cleaner.

INSPECTION OF TORQUE CONVERTER

1. INSERT SST IN END OF TORQUE CONVERTER
 - (a) Insert a turning tool in the inner race of the one-way clutch.
 - (b) Install the stopper so that it fits in the notch of the converter hub and other race of the one-way clutch.
SST 09350-20013 (09397-22020)

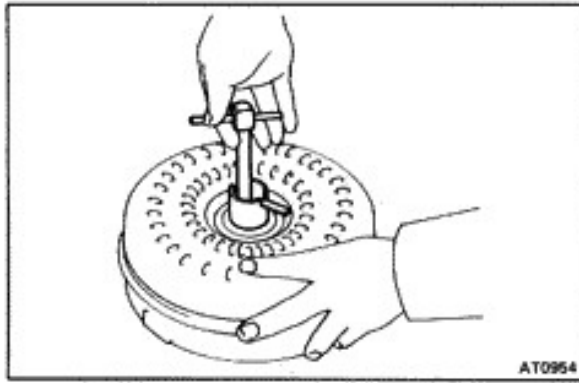

2. TEST ONE-WAY CLUTCH

The clutch should lock when turned counterclockwise, and should rotate freely and smoothly clockwise. Less than 25 kg-cm (22 in.-lb, 2.5 N-m) of torque should be required to rotate the clutch clockwise. If necessary, clean the converter and retest the clutch. Replace the converter if the clutch still fails the test.

Electrical Parts

1. INSPECT SOLENOID

Check the resistance between the terminal and body.

Standard resistance: 11 – 15 Ω

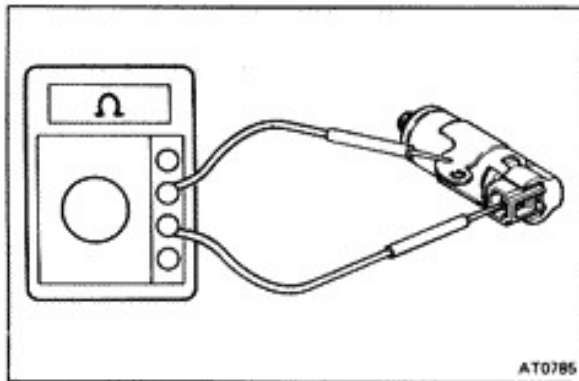

2. INSPECT NEUTRAL START SWITCH

Using an ohmmeter, check the continuity of the terminals for each switch position shown in the table below.

If continuity between the terminals is not as specified, replace the switch.

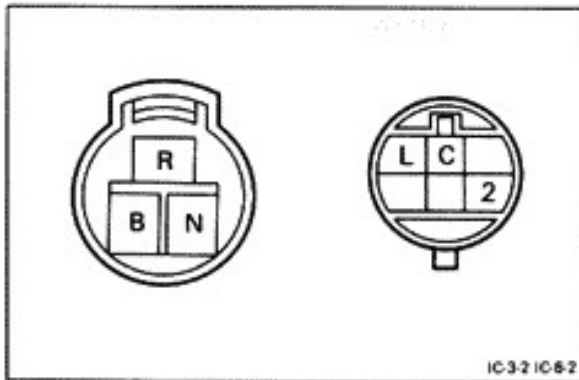

| Terminal Range | B | N | C | R | 2 | L |
|-------------------|-------|---|-------|---|-------|-------|
| P | ○ — ○ | | | | | |
| R | | | ○ — ○ | | | |
| N | ○ — ○ | | | | | |
| 2 | | | ○ — ○ | | ○ — ○ | |
| L | | | ○ — ○ | | | ○ — ○ |

3. INSPECT SPEED SENSOR

Connect an ohmmeter to the speed sensor and check that the meter deflects when the sensor is repeatedly brought close to the rotor sensor magnet and removed from it.

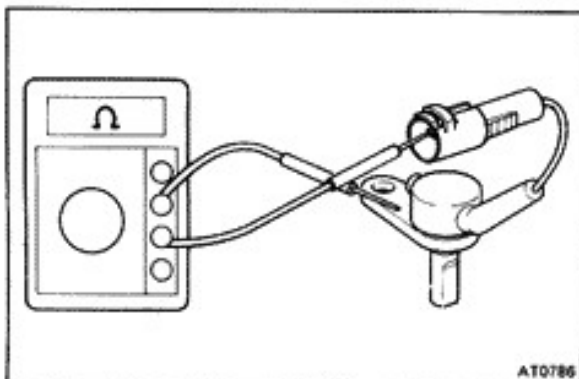

ASSEMBLY OF TRANSMISSION

Disassembly, inspection and assembly of each component group have been indicated in the preceding chapter. This chapter deals with assembly of A43DE transmission.

GENERAL ASSEMBLY NOTE:

1. The automatic transmission is composed of highly precision-finished parts, necessitating careful inspection before assembly because even a small nick could cause fluid leakage or affect performance.
2. Before assembling new clutch discs, soak them in automatic transmission fluid for at least two hours.
3. Apply automatic transmission fluid on sliding or rotating surfaces of the parts before assembly.
4. Use petroleum jelly to keep the small parts in their places.
5. Do not use adhesive cements on gaskets and similar parts.
6. When assembling the transmission, be sure to use new gaskets and O-rings.
7. Dry all parts by blowing with compressed air. Never use shop rags.
8. Be sure to install the thrust bearings and races in the correct direction and position.

Front ←

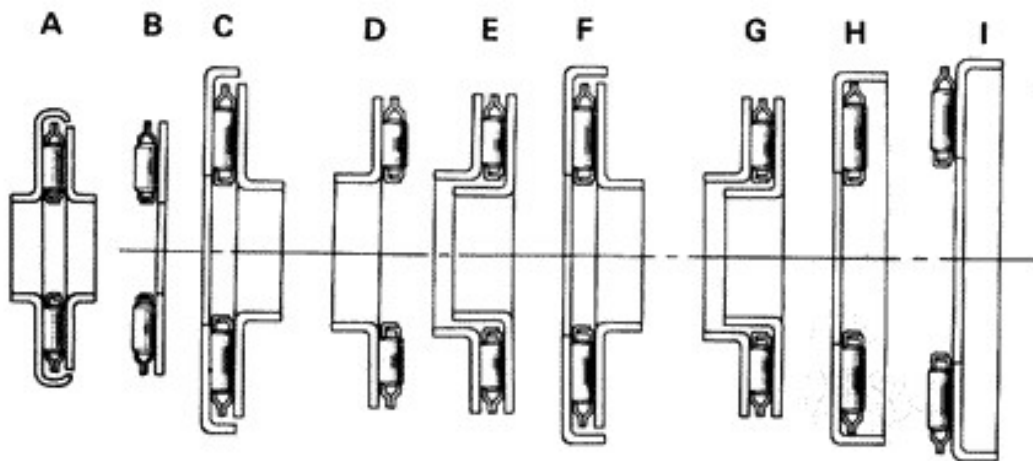
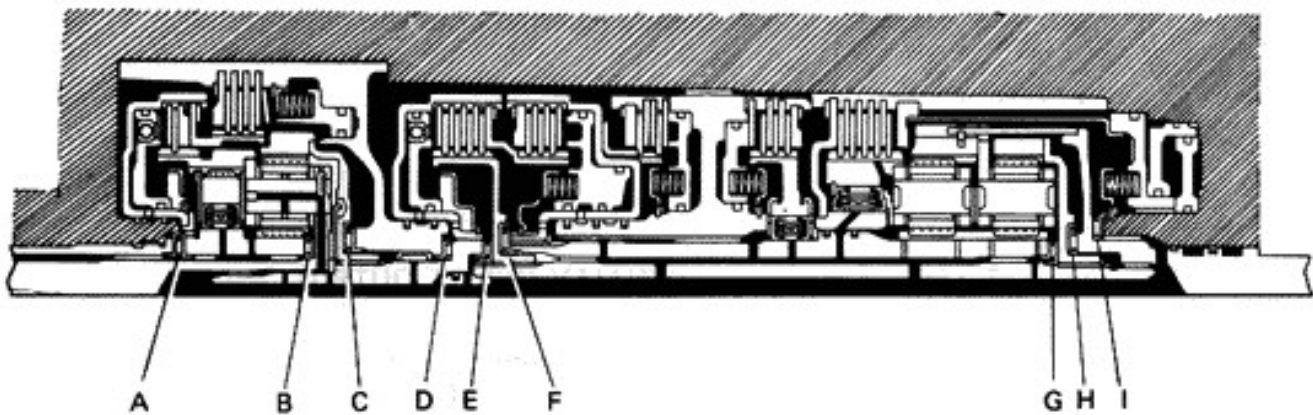

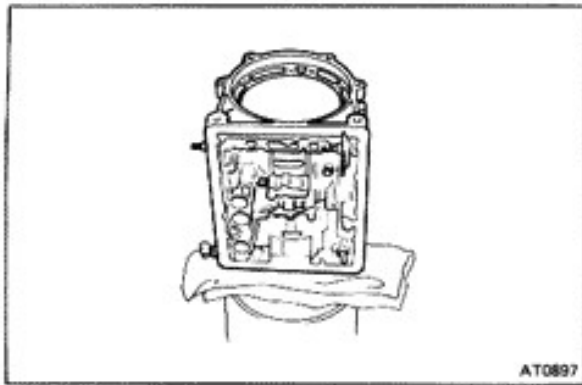

1. PLACE TRANSMISSION CASE ON CYLINDER

Place the transmission on a cylindrical stand for more efficient work.

CAUTION: Place shop rags between the case and stand to avoid damaging the case.

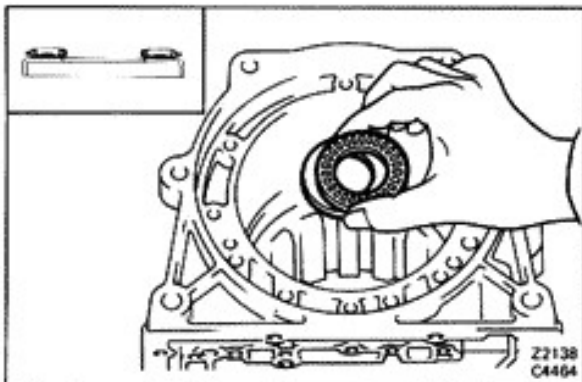

2. INSTALL THRUST WASHER AND BEARING

Install the thrust washer, facing the cup side downward.

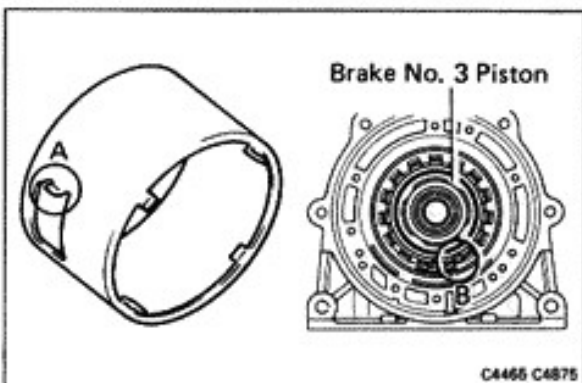

3. INSTALL APPLY TUBE IN CASE

Install the tube aligning its locking tab (part A) with part B of the case.

NOTE: Make sure that the lips of the tube end are completely inserted onto the outer piston.

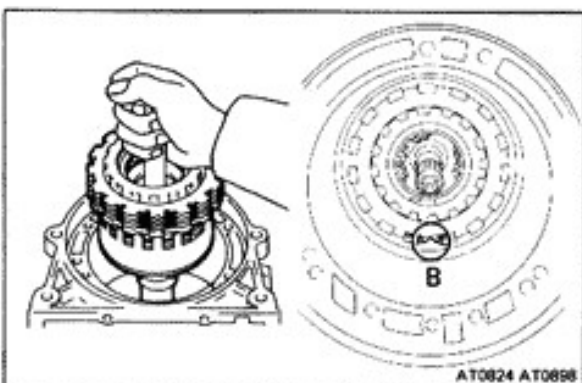

4. PARTIALLY INSERT OUTPUT SHAFT ASSEMBLY INTO CASE

Align the opening notch (part A) of the clutch plates with the slot (part B) of the case.

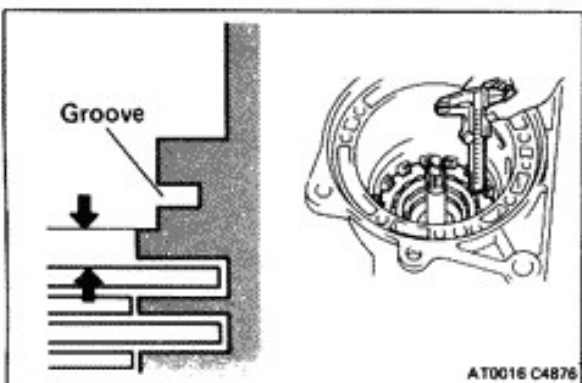

5. CHECK CLUTCH PACK CLEARANCE

With the case in upright position, make sure that the clutch pack is lower than the ledge below the snap ring groove. If the clutch pack is not lower than the ledge, components may be misassembled or there may be excess ATF on the discs.

Standard clearance: 0.61 – 2.64 mm
(0.0240 – 0.1039 in.)

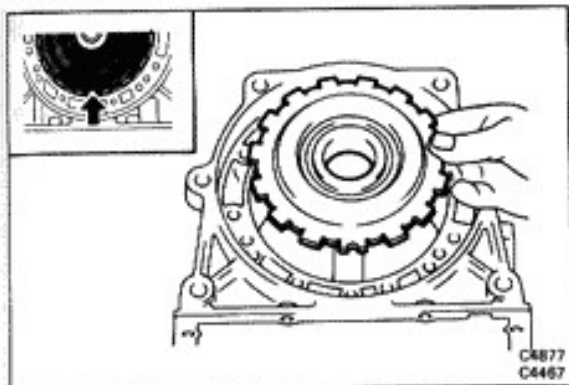
**6. INSTALL REACTION PLATE**

Position the notched tooth of the reaction plate toward the valve body side of the case. Push it into place.

NOTE: The reaction plate is correctly installed if the snap ring groove is fully visible.

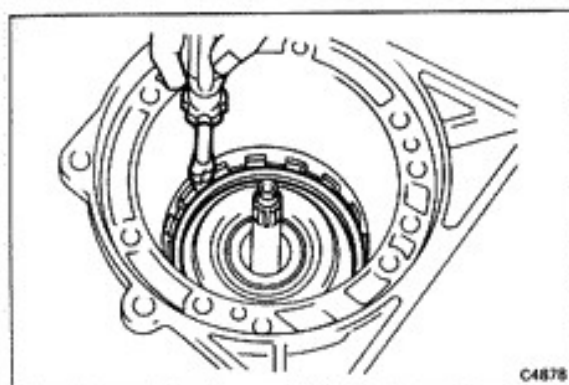
**7. INSTALL SNAP RING**

Use a large screwdriver to compress the snap ring. Push it into place by hand. Work around the case. Visually check to make sure that the ring is fully seated. Make sure that the ends of the snap ring are between the lugs.

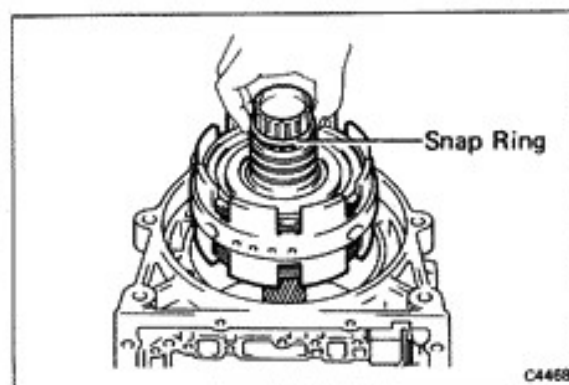
**8. PUSH CENTER SUPPORT ASSEMBLY INTO CASE**

Align the oil hole and bolt hole of the center support with those of the body side and insert.

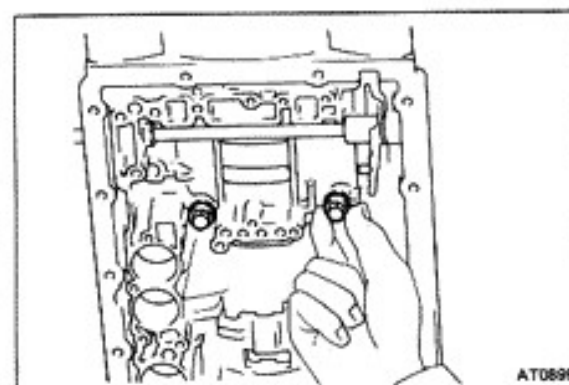
**9. INSTALL TWO CENTER SUPPORT BOLTS WITH WAVE WASHERS**

Align the center support with holes in the case and install the two bolts finger tight.

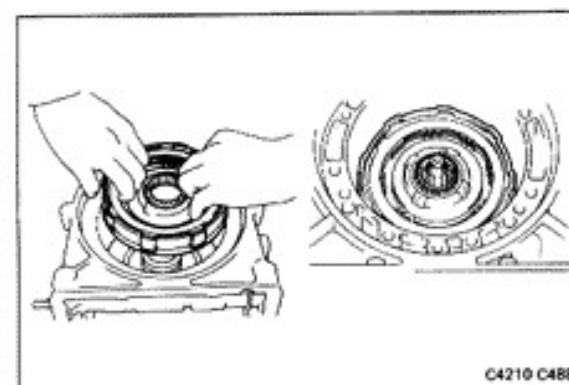
**10. INSTALL REAR CLUTCH IN CASE**

Rotate the clutch to mesh the hub with the center support.

11. CHECK FOR CORRECT INSTALLATION OF REAR CLUTCH

If the rear clutch is fully meshed with the center support, the splined center of the clutch will be flush with the end of the sun gear shaft.

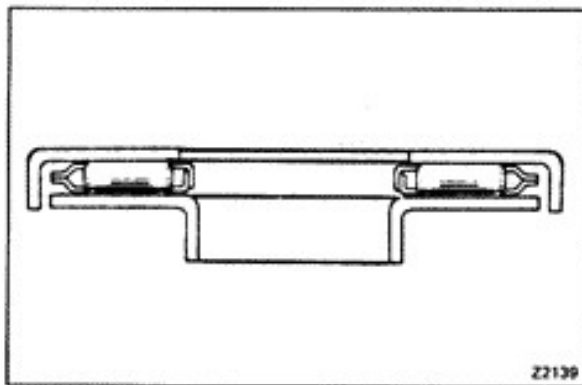

12. INSTALL NEEDLE BEARING RACE OVER SPLINED END OF REAR CLUTCH IN CASE

Coat the parts with petroleum jelly to keep them in place. Position the lip of the race toward the rear clutch.

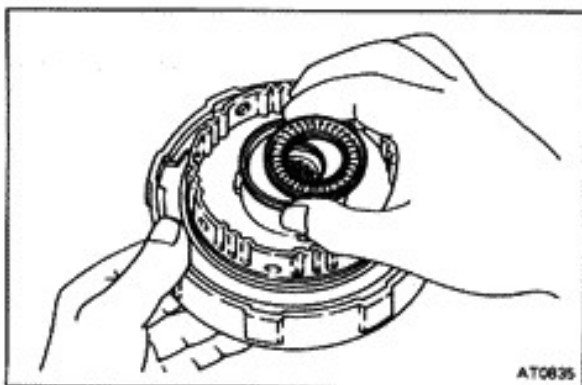

13. INSTALL THRUST BEARING AND RACE ON FRONT CLUTCH

Coat the parts with petroleum jelly to keep them in the place. Position the lip of the race outward.

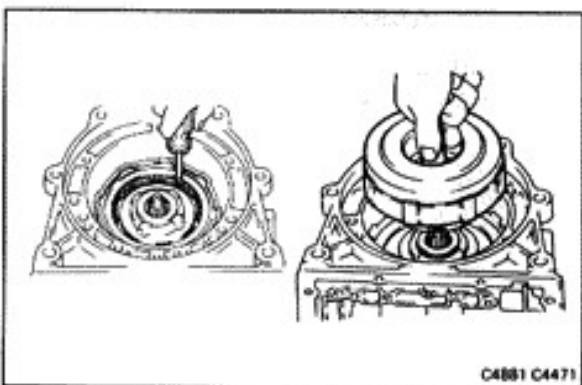

14. INSTALL FRONT CLUTCH ASSEMBLY IN CASE

Align the flukes of the rear clutch discs and mesh them with front clutch hub. Push the front clutch assembly into the case.

CAUTION: Be careful that the thrust bearing does not fall out.

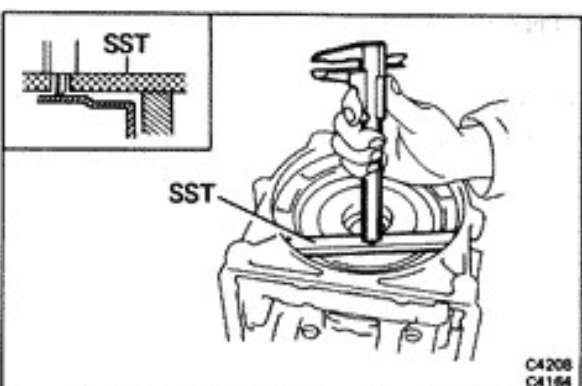

15. CHECK CORRECT INSTALLATION OF FRONT CLUTCH

Set SST on the transmission case as shown in the figure. Measure the distance between the top surface of the SST and front clutch assembly. If the distance corresponds to that during disassembly, the front clutch is installed correctly.

SST 09350-20013 (09370-12010)

Height: Measured value minus SST width =
Approx. 2mm (0.08 in.)

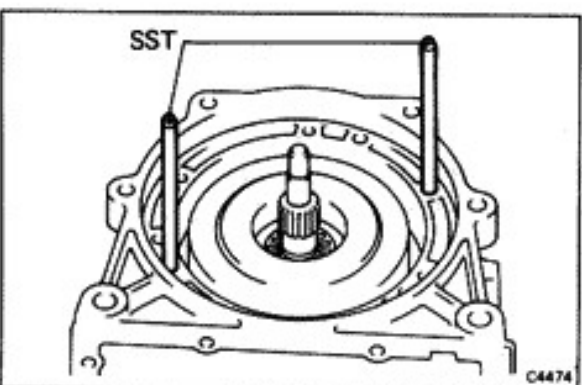

16. INSTALL THRUST BEARING ON FRONT CLUTCH

Coat the thrust bearing with petroleum jelly and set it into place.

17. INSTALL SST ON CASE

Finger tighten the SST on the transmission case.

SST 09350-20013 (09362-30011)

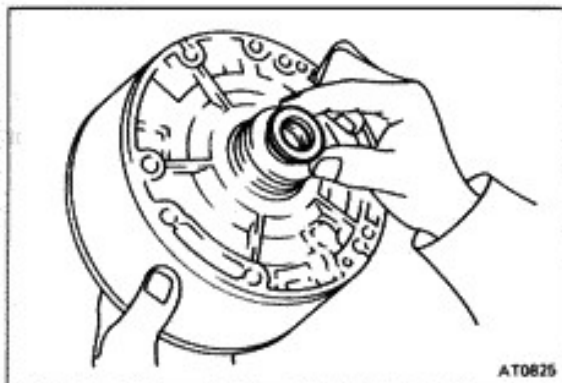

AT0826

18. INSTALL THRUST WASHER ON OVERDRIVE CASE END

Coat the thrust washer with petroleum jelly and set it into place facing the lip side toward the overdrive case.

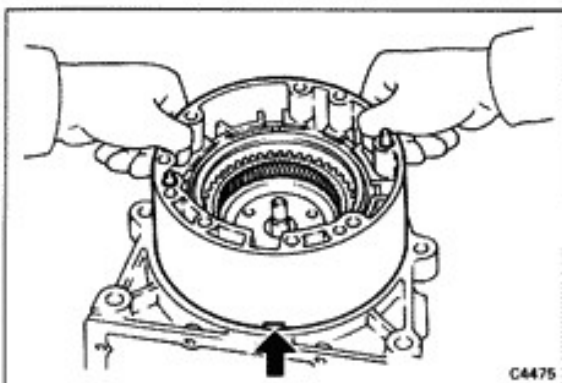

C4475

19. INSERT OVERDRIVE CASE INTO TRANSMISSION CASE

Insert the overdrive case gently through the two guide bolts (SST) with the circled part in the figure facing in the direction indicated.

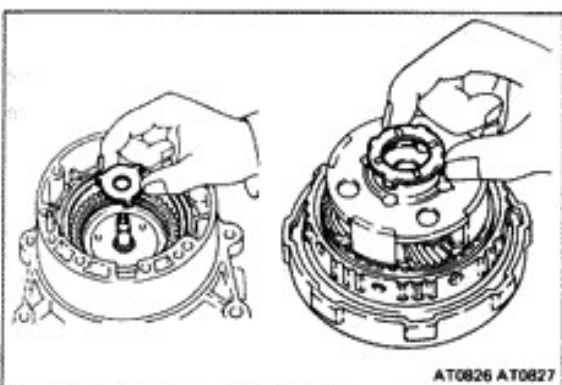

AT0826 AT0827

20. INSTALL TWO THRUST WASHERS

Coat the thrust washers with petroleum jelly. Install one thrust washer on the overdrive case and the other one on the overdrive clutch.

NOTE: The washer lugs should be inserted in the holes.

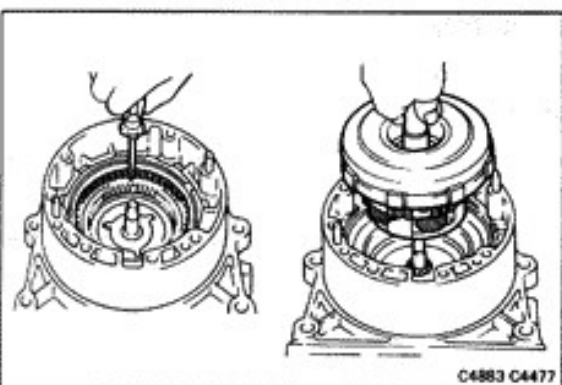

C4883 C4477

21. INSTALL OVERDRIVE CLUTCH IN CASE

Align the flukes of the discs in the overdrive case. Align the flukes with the slots of the overdrive clutch and press the overdrive clutch into the overdrive case.

CAUTION: Be careful that the thrust washer does not fall out.

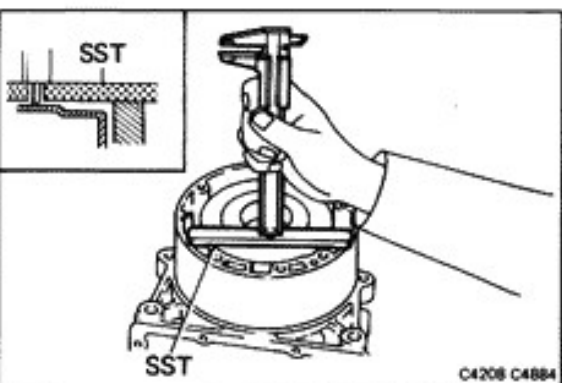

C4208 C4884

22. CHECK CORRECT INSTALLATION OF OVERDRIVE CLUTCH

Set SST on the overdrive case as shown in the figure. Measure the distance between the top surface of SST and the overdrive clutch. If the distance corresponds to that during disassembly, the overdrive clutch is installed correctly.

SST 09350-20013 (09370-12010)

Height: Measure value minus SST width =
Approx. 3.5 mm (0.138 in.)

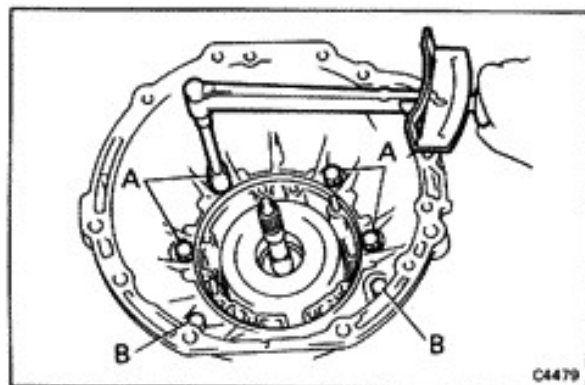
**23. INSTALL O-RING ON OVERDRIVE CASE****24. INSTALL CONVERTER HOUSING**

Install the two 12-mm bolts at B and four 10-mm bolts at A and tighten them.

Torque: A bolts 345 kg-cm (25 ft-lb, 34 N·m)
B bolts 580 kg-cm (42 ft-lb, 57 N·m)

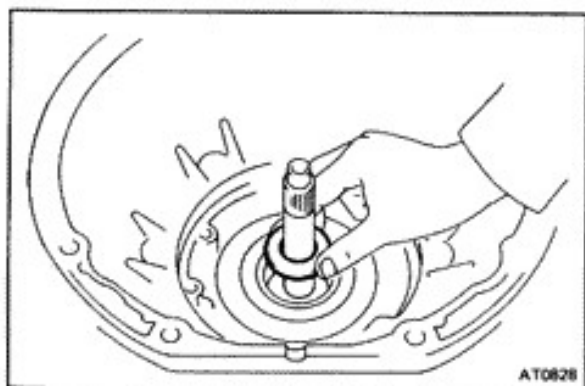
**25. INSTALL RACE ON OVERDRIVE CLUTCH**

Install the thrust washer, facing the lip side outward.

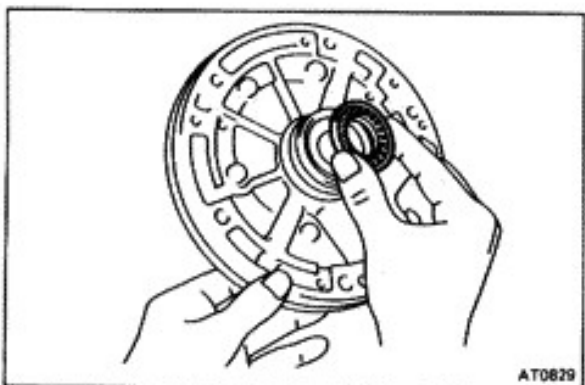
**26. INSTALL THRUST BEARING ON FRONT OIL PUMP**

Coat the thrust washer with petroleum jelly and install the washer side toward the pump body together with the bearing.

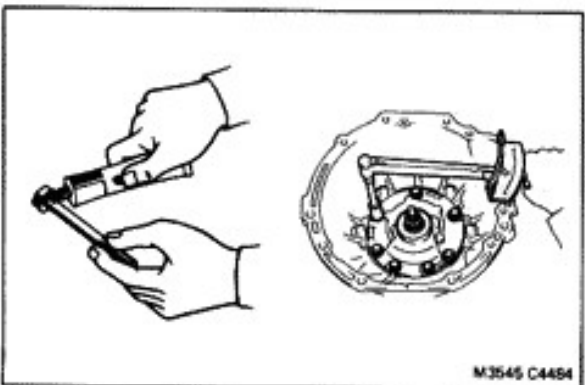
**27. INSTALL FRONT OIL PUMP**

(a) Install the oil pump gently through the two guide pins, being careful that the thrust washer does not fall out.

(b) Coat the five set bolts with seal packing and finger tighten them.

(c) Using a screwdriver, remove the SST, and install the two set bolts coated with seal packing.

SST 09350-20013 (09362-30011)

(d) Tighten the set bolts gradually and uniformly.

Torque: 215 kg-cm (16 ft-lb, 21 N·m)

28. TIGHTEN TWO CENTER SUPPORT BOLTS

Tighten the bolts alternately in 70 kg-cm (61 in.-lb, 6.9 N·m) increments.

Torque: 260 kg-cm (19 ft-lb, 25 N·m)

NOTE: First tighten the accumulator side bolt.

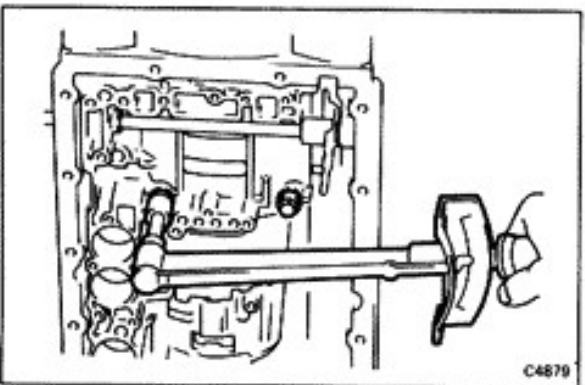

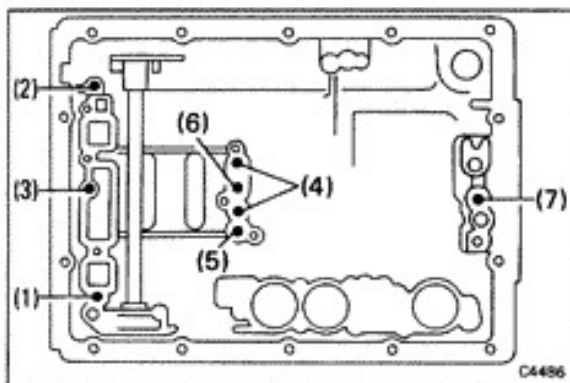

29. CHECK OPERATION OF PISTONS

Blow low-pressure compressed air into the passages indicated on the figure and listen for noise from piston movement.

- (1) Overdrive clutch
- (2) Overdrive brake
- (3) Front clutch
- (4) Rear clutch
- (5) Brake No. 1
- (6) Brake No. 2
- (7) Brake No. 3

If pistons do not move, disassemble and inspect.

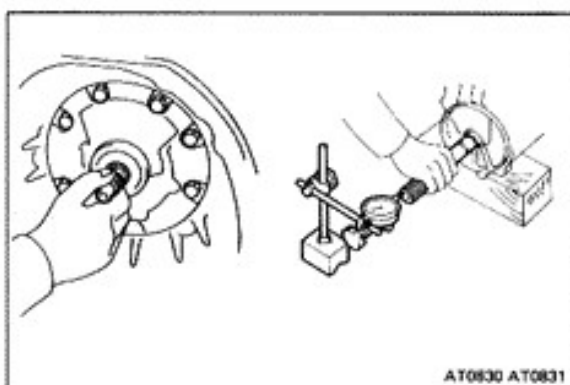

30. CHECK INPUT SHAFT AND OUTPUT SHAFT

- (a) Make sure that the input shaft has play in axial direction and that it turns.
- (b) Make sure that the output shaft has thrust play in axial direction.

Thrust play: 0.3 – 0.9 mm (0.012 – 0.035 in.)

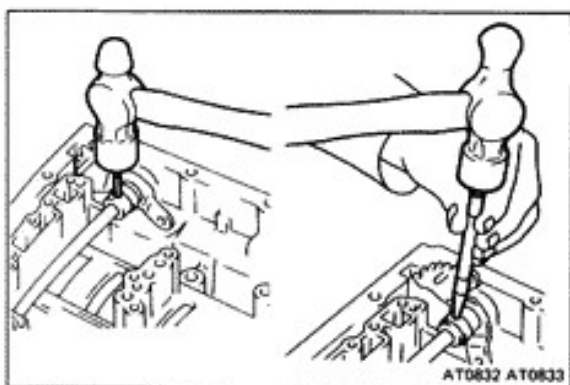

31. IF NECESSARY, INSTALL MANUAL VALVE LEVER SHAFT INTO CASE

- (a) Assemble a new collar to the manual valve lever.
NOTE: Always replace the collar with a new one.
- (b) Install the manual valve lever shaft to the transmission case through the manual valve lever.
- (c) Drive in the roll pin with the slot at right angle to the shaft.
- (d) Match the collar hole to the lever staking hollow and stake the collar to the lever.

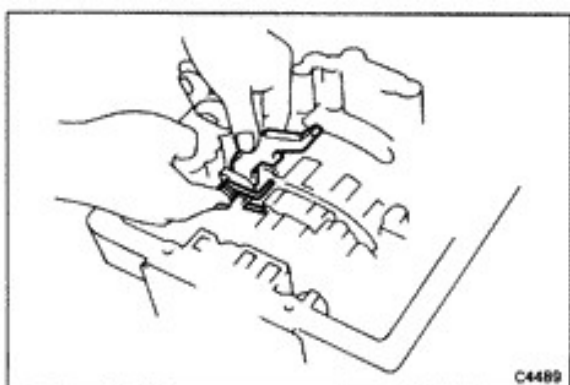

32. INSTALL PARKING LOCK PAWL, PIVOT PIN AND SPRING IN CASE

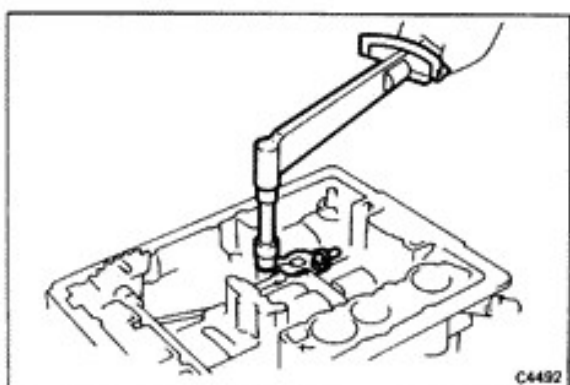

33. INSTALL PARKING LOCK PAWL BRACKET ON CASE

Make sure the collar on the control rod is facing toward the front of the transmission.

Tighten the two bolts. Make sure the pawl moves freely.

NOTE: It is possible for the bracket to be installed too far forward, where it will bind the pawl.

Torque: 75 kg-cm (65 in.-lb, 7.4 N-m)

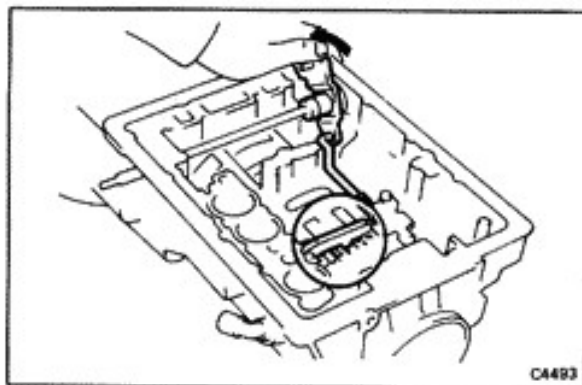

C4493

34. CHECK OPERATION OF PARKING LOCK PAWL

Make sure the planetary gear output shaft is locked when the manual valve lever is in "P" range.

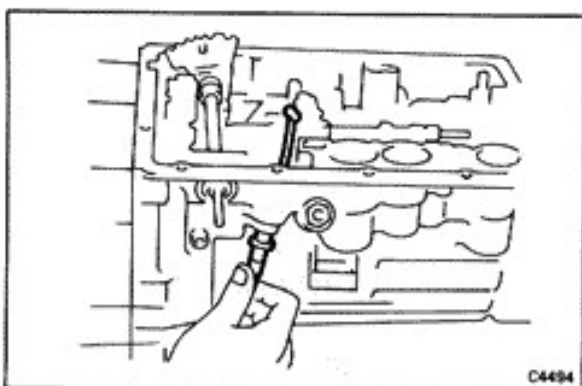

C4494

35. INSTALL NEW O-RING ON THROTTLE CABLE FITTING**36. INSTALL THROTTLE CABLE IN CASE**

Push the cable through the case, being careful not to damage the O-ring. Check for full seating.

CAUTION: In subsequent work, be careful not to roll the case over the cable and break the cable fitting.

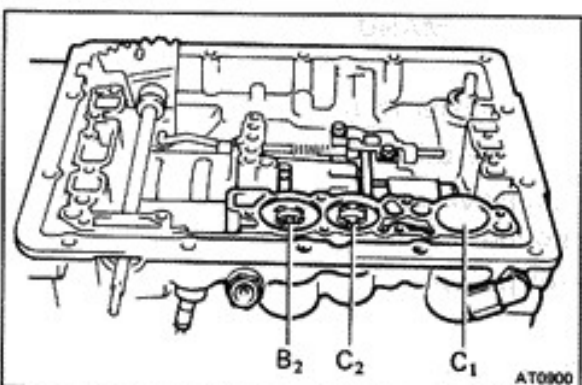

AT0900

37. INSTALL ACCUMULATOR PISTON AND SPRINGS

| Spring | | Free length | Outer diameter | Wire diameter | Color |
|----------------|-------|----------------|----------------|---------------|------------|
| B ₂ | Upper | 50.68 (1.9953) | 20.00 (0.7874) | 2.80 (0.1102) | Light Gray |
| | Lower | 35.13 (1.3831) | 16.16 (0.6362) | 1.30 (0.0512) | Red |
| C ₂ | Upper | 43.56 (1.7150) | 14.30 (0.5630) | 1.80 (0.0709) | Blue |
| | Lower | 32.73 (1.2886) | 14.80 (0.5827) | 1.30 (0.0512) | Green |
| C ₁ | | 64.68 (2.5465) | 17.50 (0.6890) | 2.00 (0.0787) | None |

mm (in.)

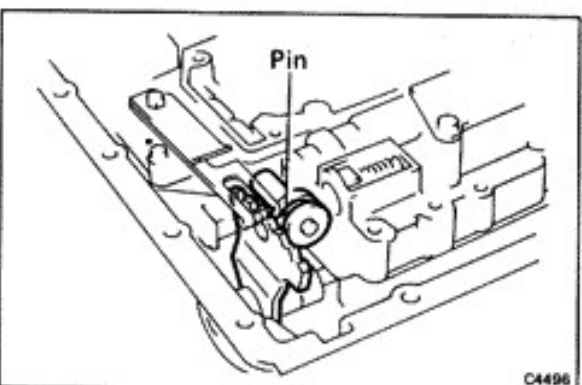

C4496

38. PLACE VALVE BODY ON TRANSMISSION

Make sure the accumulator pistons are pressed fully into the bore. Align the manual valve with the pin on the manual shift lever, and lower valve body into place.

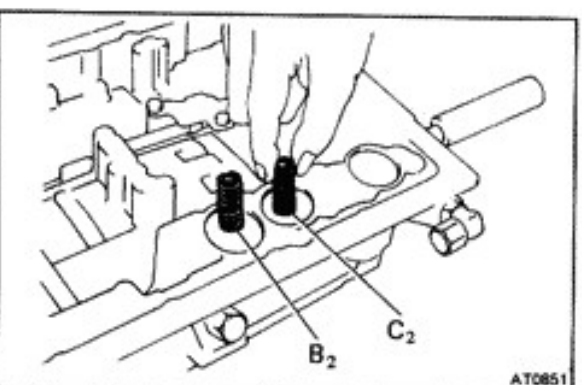

AT0851

39. LIFT SIDE OF VALVE BODY AND ATTACH THROTTLE CABLE

- While holding the cam down with your fingers, slip the cable end into the slot.
- Make sure that the B₂ and C₂ accumulator piston springs is installed onto the piston.

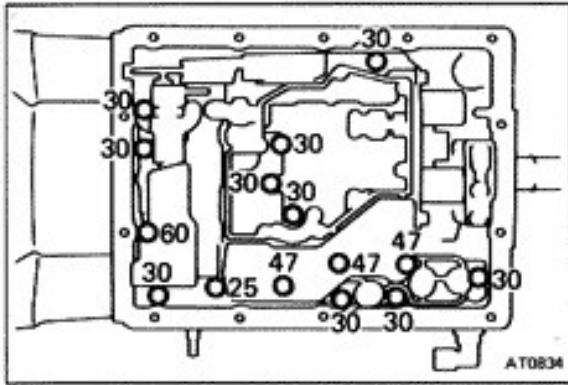
**40. INSTALL FIFTEEN BOLTS IN VALVE BODY**

Install the bolts as shown.

Torque: 100 kg-cm (7 ft-lb, 10 N·m)

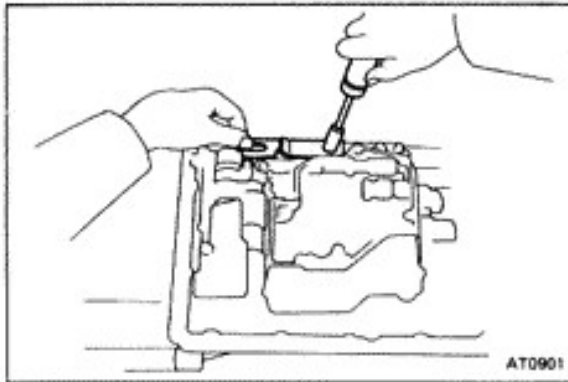
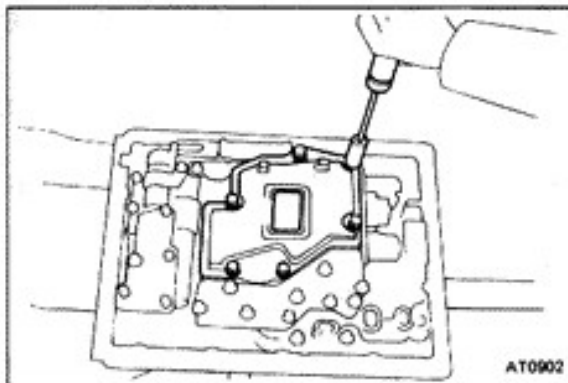
**41. INSTALL DETENT SPRING****42. INSTALL OIL STRAINER**

Torque: 55 kg-cm (48 in.-lb, 5.4 N·m)

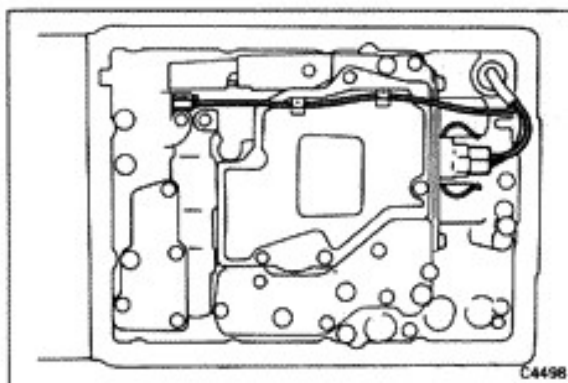
**43. CONNECT SOLENOID WIRING TO EACH SOLENOID**

- (a) Push the solenoid wiring through in the transmission case and connect the terminals to each solenoid.
- (b) Clamp the wiring to the oil screen.
- (c) Install the gromet for the wiring with the plate.

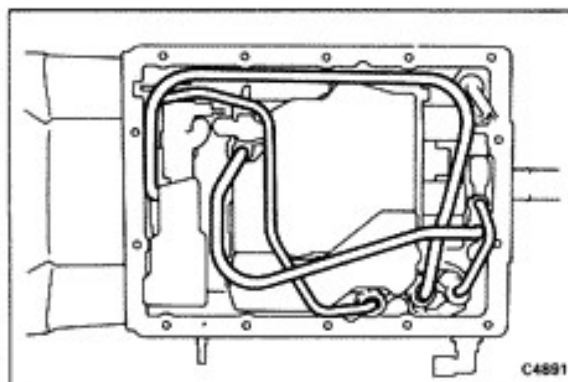
**44. INSTALL OIL TUBES**

Press the tubes by hand into the positions indicated in the figure. Make sure that the oil tubes do not interfere with the oil pan.

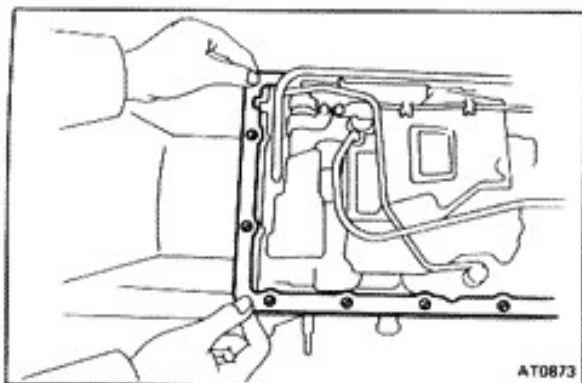

45. INSTALL TWO MAGNETS IN PAN AND INSTALL OIL PAN WITH NEW GASKET

- (a) Align the cut part of the gasket and case.

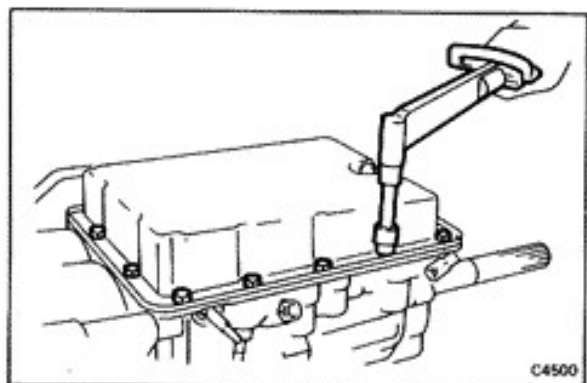

- (b) Install the oil pan.

Torque: 45 kg-cm (39 in.-lb, 4.4 N·m)

CAUTION: Make sure that the two magnets do not interfere with the oil tubes or valve body.

46. INSTALL DRAIN PLUG WITH NEW GASKET

Torque: 205 kg-cm (15 ft-lb, 20 N·m)

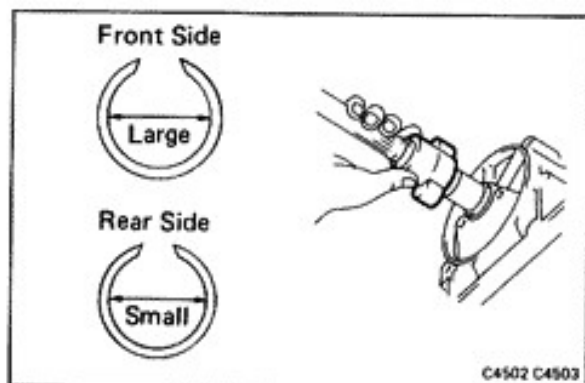

47. INSTALL SENSOR ROTOR AND SPEEDOMETER DRIVE GEAR

NOTE: Install the larger diameter snap ring at the front side.

- (a) Install the larger snap ring and woodruff key onto the shaft.
 (b) Install the sensor rotor.

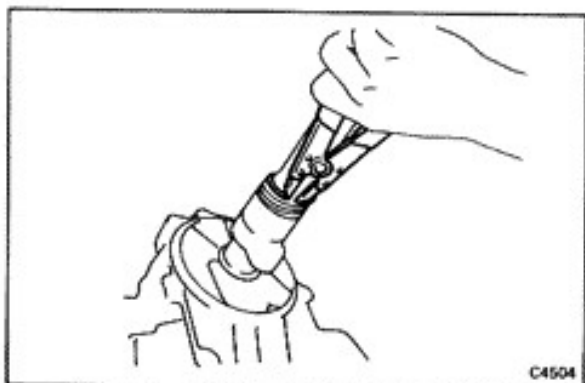

- (c) Install the lock ball.
 (d) Slide the speedometer gear on the shaft.
 (e) Using snap ring pliers, install the outer snap ring.

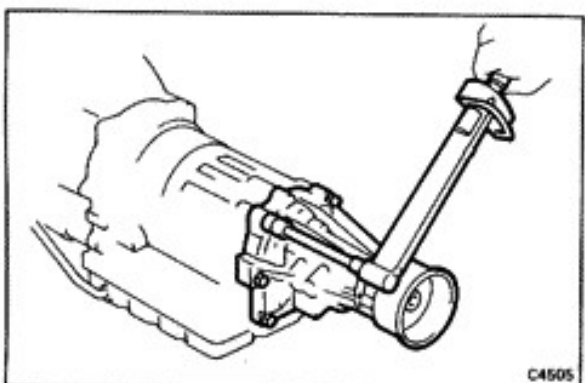

48. INSTALL EXTENSION HOUSING WITH NEW GASKET

Do not use the gasket sealer. Install the housing with four long bolts and two short bolts. Tighten the bolts.

Torque: 345 kg-cm (25 ft-lb, 34 N·m)

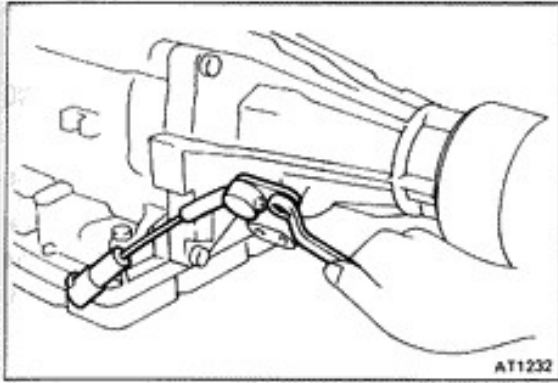
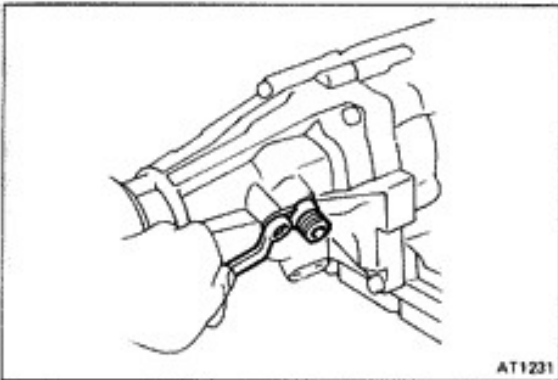
**49. INSTALL SPEED SENSOR IN EXTENSION HOUSING****50. INSTALL NEW O-RINGS, BUSHING AND SPEEDOMETER DRIVEN GEAR TO SHAFT SLEEVE****51. INSTALL SPEEDOMETER DRIVEN GEAR ASSEMBLY IN EXTENSION HOUSING**

Insert the shaft sleeve assembly into the housing. Install the lock plate with the bolt and lock washer.

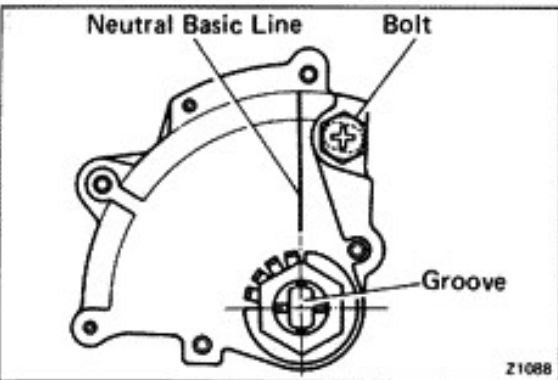
**52. INSTALL NEUTRAL START SWITCH**

- (a) Slide the neutral start switch onto the control shaft.
- (b) Install the grommet facing the groove toward the switch body and then install the washer and nut.
- (c) Move the switch so that the slit in the switch and neutral basic line match up. Tighten the bolt and nut.

Torque: Bolt 55 kg-cm (48 in-lb, 5.4 N·m)
 Nut 70 kg-cm (61 in-lb, 6.9 N·m)

53. INSTALL SHIFT HANDLE

INSTALLATION OF TRANSMISSION

1. MEASURE DRIVE PLATE RUNOUT AND INSPECT RING GEAR

Set up a dial indicator and measure the drive plate runout. If runout exceeds 0.20 mm (0.0079 in.) or if the ring gear is damaged, replace the drive plate. If installing a new drive plate, note the orientation of spacers and tighten the bolts.

Torque: 650 kg-cm (47 ft-lb, 64 N·m)

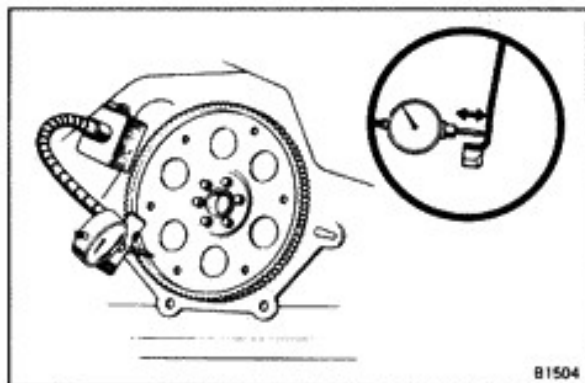

B1504

2. MEASURE TORQUE CONVERTER SLEEVE RUNOUT

(a) Temporarily mount the torque converter to the drive plate. Set up a dial indicator.

If runout exceeds 0.30 mm (0.0118 in.), try to correct by reorienting the installation of the converter. If excessive runout cannot be corrected, replace the torque converter.

NOTE: Mark the position of the converter to ensure correct installation.

(b) Remove the torque converter.

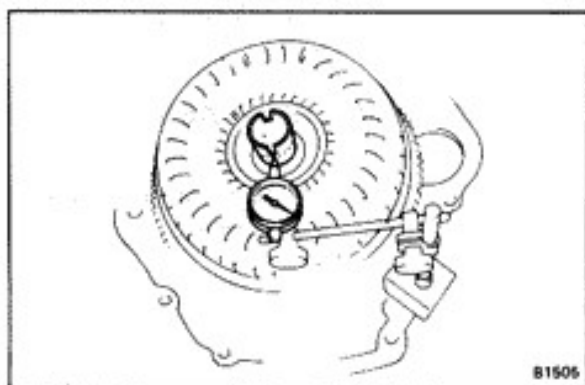

B1506

3. INSTALL ENGINE REAR MOUNT INSULATOR EXTENSION HOUSING

(a) Inspect the insulator for deterioration and replace if necessary.

(b) Install the ground cable between mount and case.

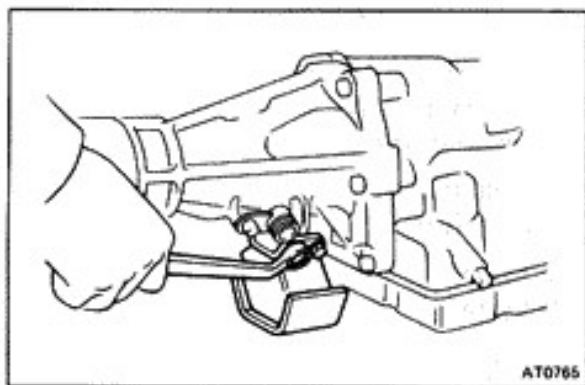

AT0765

4. INSTALL FILLER TUBE

Replace a new O-ring and push the tube into place.

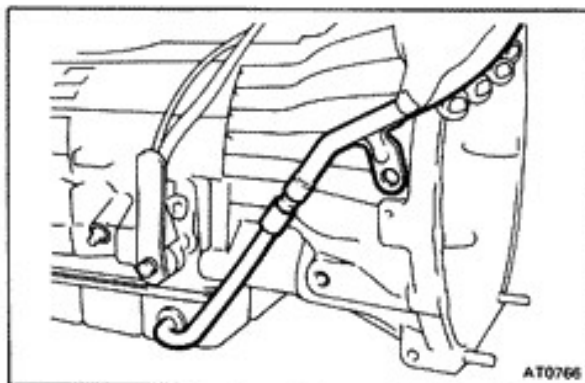

AT0766

5. APPLY GREASE TO CENTER HUB OF TORQUE CONVERTER AND PILOT HOLE IN CRANKSHAFT

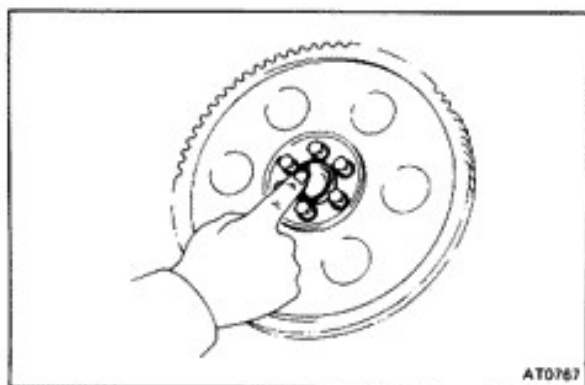

AT0767

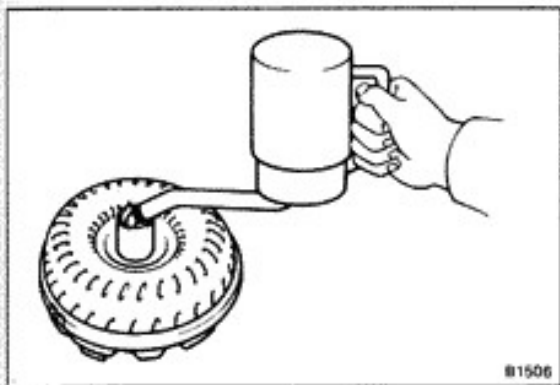

6. INSTALL TORQUE CONVERTER IN TRANSMISSION

If the torque converter has been drained and washed, refill with fresh ATF.

ATF capacity: 2.0 liters (2.1 US qts, 1.8 Imp. qts)

Fluid type: ATF DEXRON® II

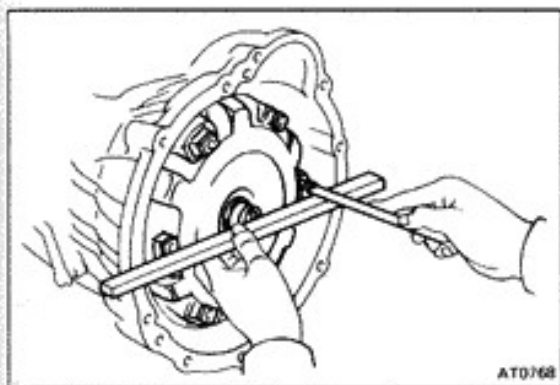

7. CHECK TORQUE CONVERTER INSTALLATION

Using calipers and a straight edge, measure from the installed surface to the front surface of the transmission housing.

Correct distance: 26 mm (1.02 in.)

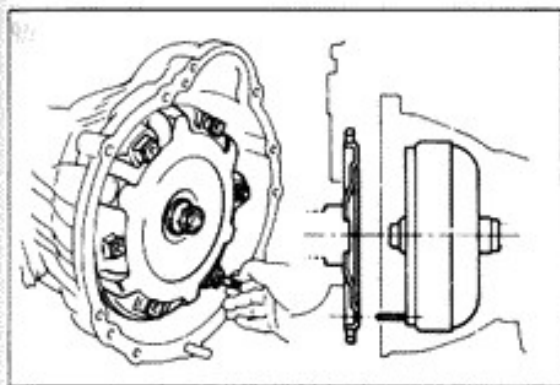

8. INSTALL GUIDE PIN IN TORQUE CONVERTER

9. ALIGN TRANSMISSION AT INSTALLATION POSITION

CAUTION: Be careful not to tilt the transmission forward because the torque converter could slide out.

- Align the guide pin with one of the drive plate holes.
- Align two sleeves on the block with the converter housing.
- Temporarily install one bolt.

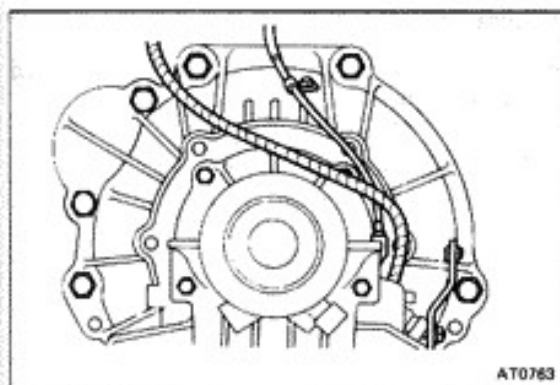

10. INSTALL TRANSMISSION HOUSING MOUNTING BOLTS

- Install the starter.
- Install the four transmission housing mounting bolts.

Torque: 650 kg-cm (47 ft-lb, 64 N·m)

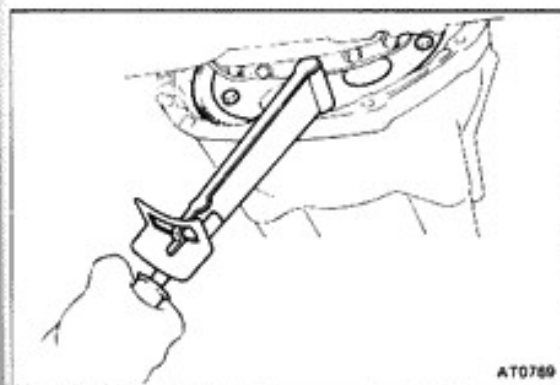

11. INSTALL SIX TORQUE CONVERTER BOLTS

- Remove the guide pin.
- Install the six bolts finger tight. Turn the crankshaft to gain access.
- Tighten the bolts evenly.

Torque: 280 kg-cm (20 ft-lb, 27 N·m)

12. INSTALL ENGINE UNDER COVER

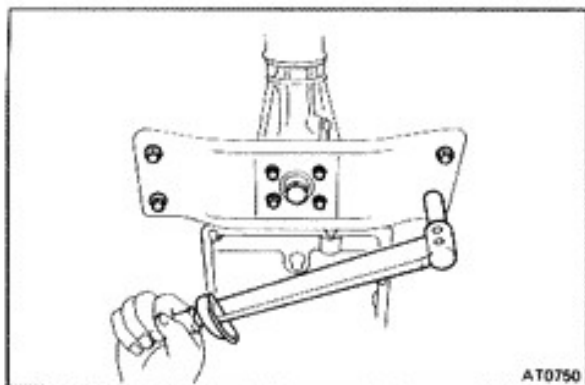

AT0750

13. INSTALL REAR SUPPORT MEMBER ON BODY

- (a) Install the two bolts at each end of the support.
- (b) Connect the ground strap.

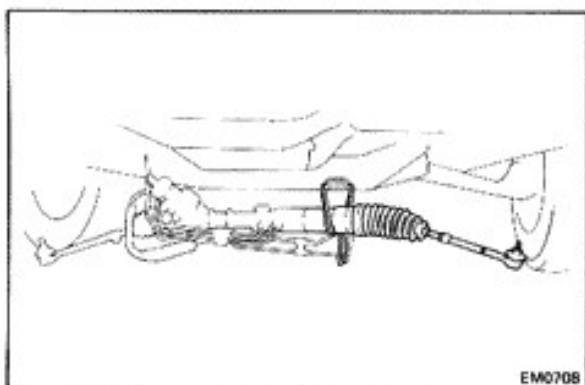
14. LOWER TRANSMISSION, AND INSTALL FOUR REMAINING MOUNTING BOLTS

EM0708

15. INSTALL POWER STEERING GEAR HOUSING

- (a) Install the rubber cushions on the gear housing.
- (b) Install the gear housing on the crossmember.
- (c) Install the brackets and tighten the four bolts.

Torque: 770 kg-cm (56 ft-lb, 76 N·m)

- (d) Install the clamps of fluid line.
- (e) Connect the both tie rod ends to the knuckle arm.

Torque: 600 kg-cm (43 ft-lb, 59 N·m)

- (f) Install the intermediate shaft.

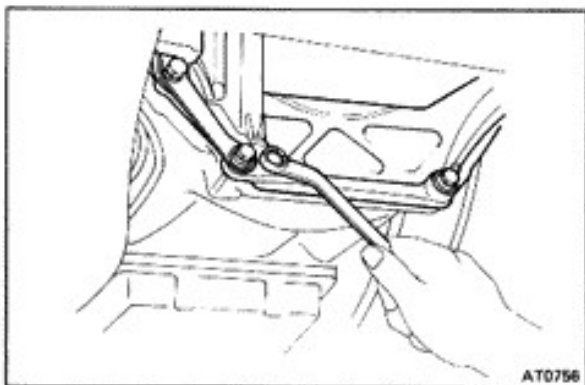
16. INSTALL CONVERTER COVER, EXHAUST PIPE CLAMP AND BOTH STIFFENER PLATES

AT0756

17. CONNECT SPEEDOMETER CABLE

Be sure the felt dust protector and washer are on the end of the cable. Tighten the collar with pliers.

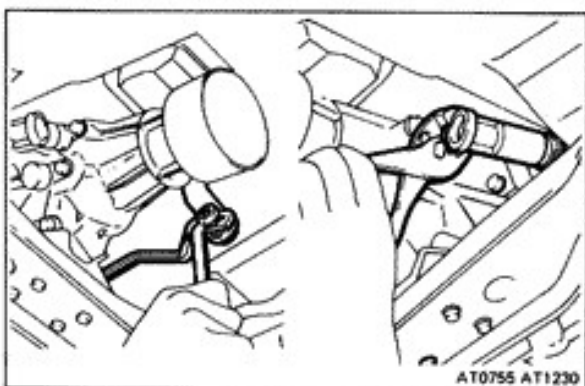
18. CONNECT MANUAL SHIFT LINKAGE

AT0755 AT1230

19. CONNECT OIL COOLER LINES

Torque: 350 kg-cm (25 ft-lb, 34 N·m)

20. CONNECT COOLING LINE BRACKET

Torque: 650 kg-cm (47 ft-lb, 64 N·m)

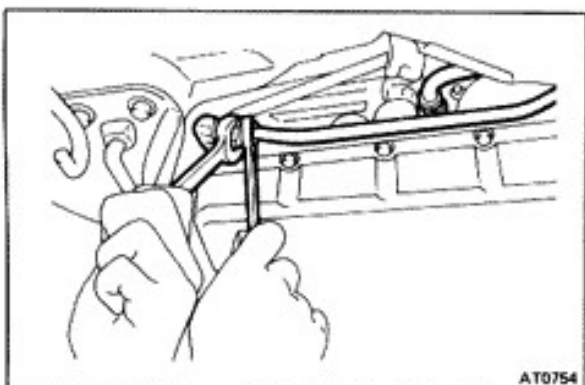

AT0754

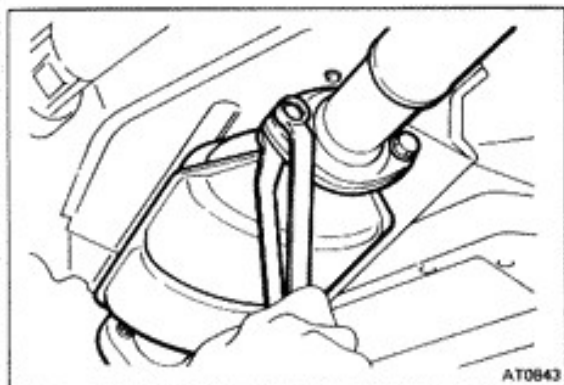
**21. CONNECT TAIL PIPE AND FRONT PIPE**

- (a) Connect the pipe to the tail pipe.
- (b) Install the two rubber hangers.
- (c) Install the pipe clamp to the transmission case.

Torque: 440 kg-cm (32 ft-lb, 43 N·m)

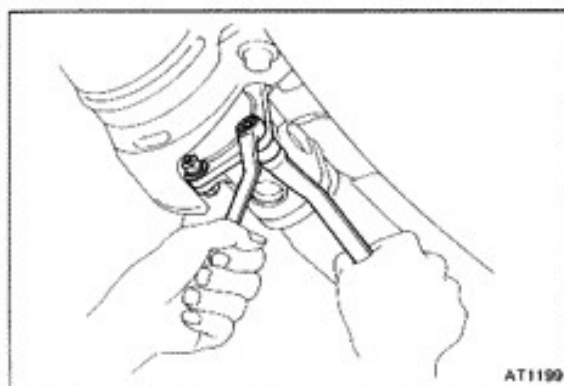
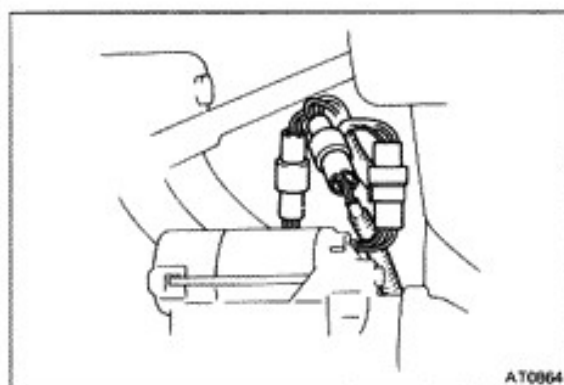
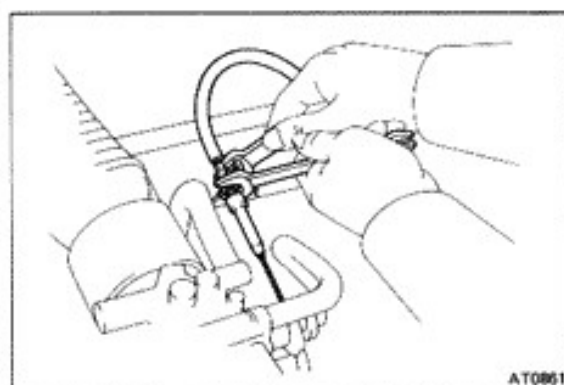
**22. INSTALL INTERMEDIATE PROPELLER SHAFT****23. CONNECT WIRING CONNECTORS TO NEUTRAL START AND BACK-UP LIGHT SWITCHES****24. CONNECT TRANSMISSION THROTTLE CABLE**

- (a) Connect the cable to the throttle linkage.
- (b) Connect the cable housing to the bracket.

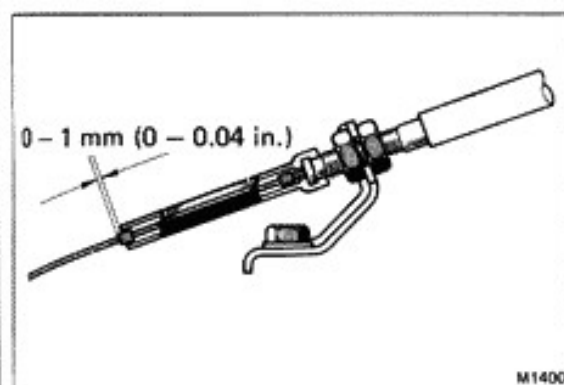
**25. ADJUST TRANSMISSION THROTTLE CABLE****26. CONNECT UPPER RADIATOR HOSE AND FILL WITH COOLANT****27. CONNECT BATTERY CABLE TO NEGATIVE (-) TERMINAL**

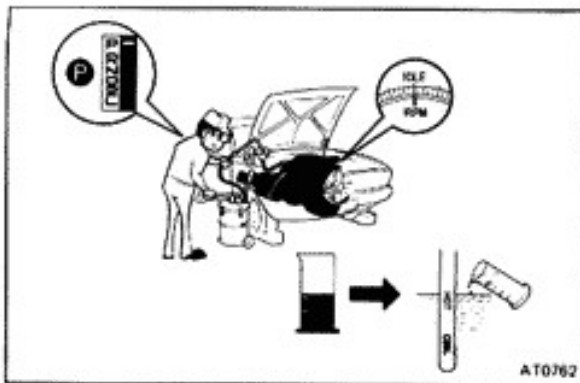
**28. FILL TRANSMISSION WITH ATF**

Add about 4.0 liters (4.2 US qts, 3.5 Imp. qts).

Fluid type: **ATF DEXRON® II**

Total capacity: **6.5 liters (6.9 US qts, 5.7 Imp. qts)**

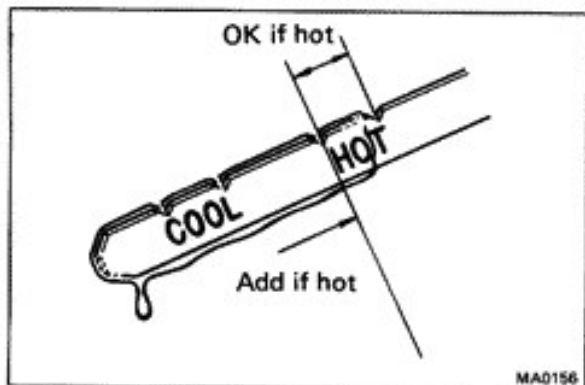
**29. CHECK FLUID LEVEL (See page MA-13)****30. PERFORM ROAD TEST**

Check for abnormal noise, shock, slippage, correct shift points and smooth operation.

PROPELLER SHAFT

| | Page |
|-----------------------|------|
| PRECAUTIONS | PR-2 |
| TROUBLESHOOTING | PR-2 |
| PROPELLER SHAFT | PR-3 |

PRECAUTIONS

1. As the universal joint is a non-disassembly type, the propeller shaft or intermediate shaft must be replaced as an assembly in event of universal joint trouble.
2. Be careful not to grip the propeller shaft tube too tightly in the vise as this will cause deformation.

TROUBLESHOOTING

| Problem | Possible cause | Remedy | Page |
|-----------|--|---|-------|
| Noise | Sleeve yoke spline worn | Replace intermediate shaft | PR-4 |
| | Center bearing worn | Replace center bearing | PR-4 |
| | Spider bearing worn or stuck | Replace intermediate shaft or propeller shaft | PR-4 |
| Vibration | Propeller shaft runout | Replace propeller shaft | PR-4 |
| | Propeller shaft unbalance | Balance propeller shaft | PR-4 |
| | Transmission extension housing rear bushing worn | Replace bushing | MT-15 |
| | Sleeve yoke spline stuck | Replace intermediate shaft | PR-4 |

PROPELLER SHAFT COMPONENTS

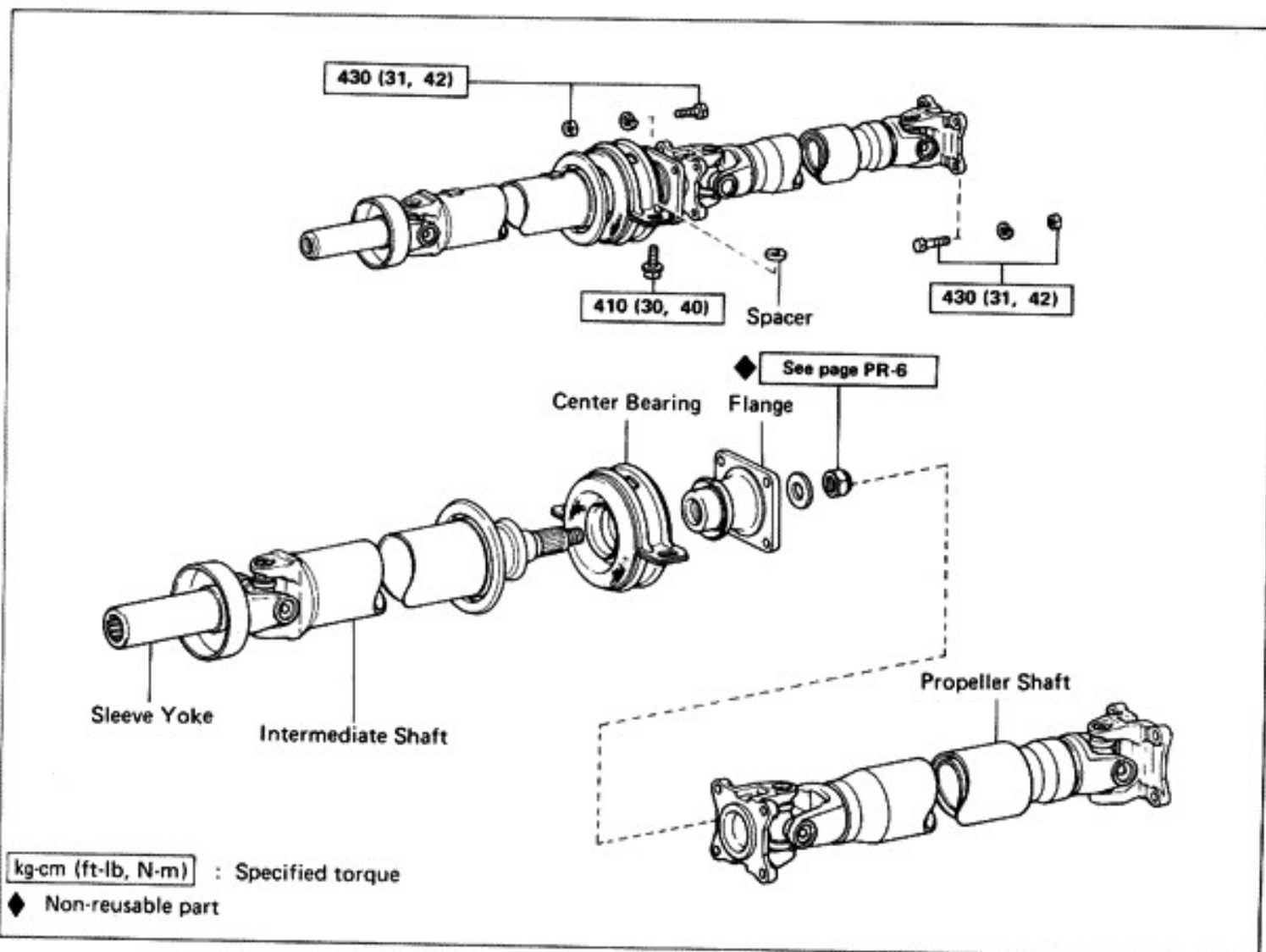

REMOVAL OF PROPELLER SHAFT

1. **DISCONNECT PROPELLER SHAFT FLANGE FROM FLANGE ON DIFFERENTIAL**
 - (a) Place matchmarks on the flanges.
 - (b) Remove the four bolts and nuts.
2. **REMOVE CENTER SUPPORT BEARING FROM BODY**
3. **REMOVE PROPELLER SHAFT**
 - (a) Remove the center bearing mounting bolts.
 - (b) Pull out the propeller shaft from the transmission.
 - (c) Insert SST in the transmission to prevent oil leakage.
SST 09325-20010

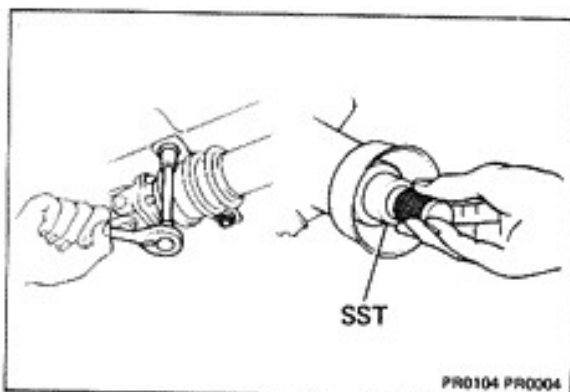
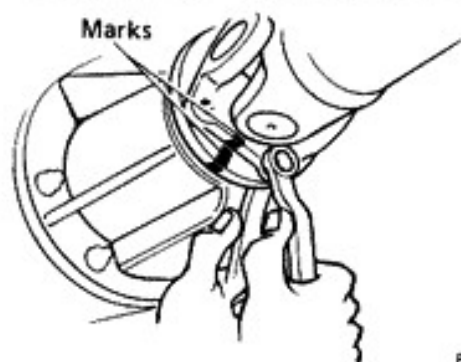

DISASSEMBLY OF PROPELLER SHAFT**1. SEPARATE PROPELLER SHAFT AND INTERMEDIATE SHAFT**

- (a) Place matchmarks on the flanges.
- (b) Remove the four bolts and nuts.

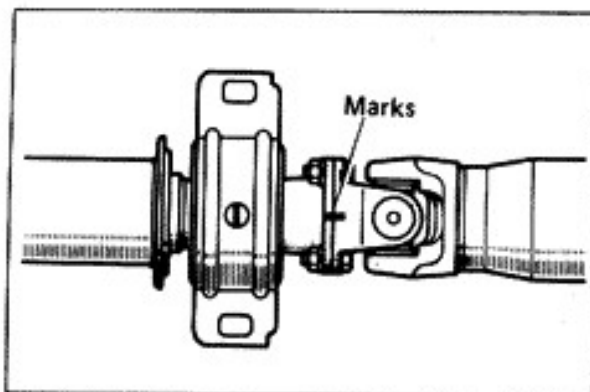
**2. REMOVE CENTER SUPPORT BEARING FROM INTERMEDIATE SHAFT**

- (a) Using a hammer and chisel, loosen the staked part of the nut.

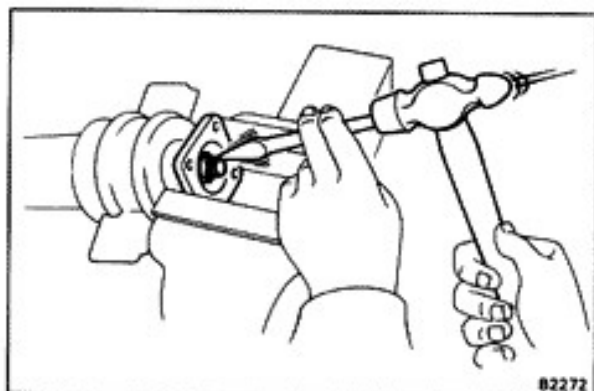

- (b) Using SST to hold the flange, remove the nut. SST 09330-00021

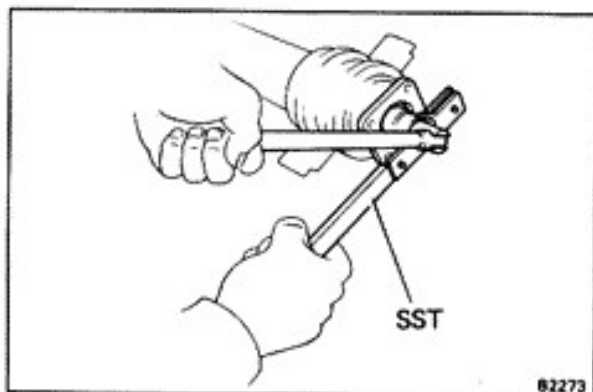

- (c) Place alignment marks on the flange or yoke and shaft.

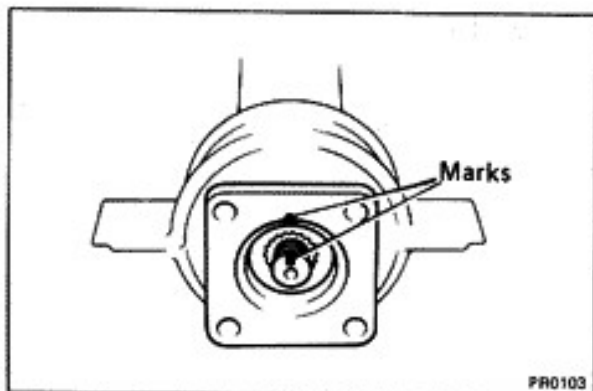

- (d) Clamp the flange or yoke in a vise and tap off the shaft.

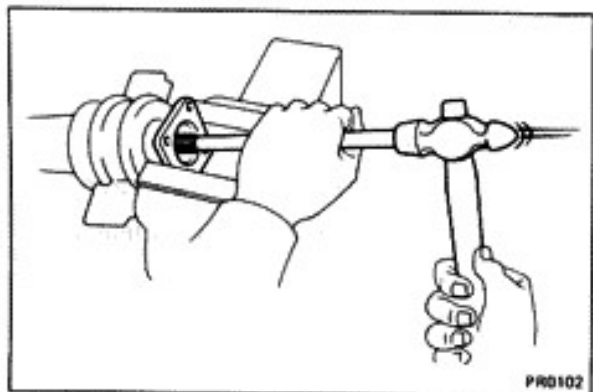

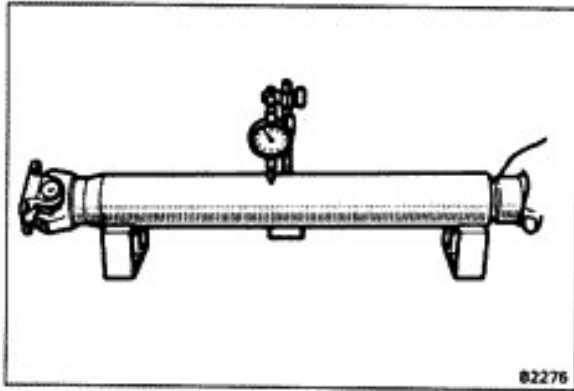

INSPECTION OF PROPELLER SHAFT COMPONENTS

1. INSPECT PROPELLER AND INTERMEDIATE SHAFTS FOR DAMAGE OR RUNOUT

If shaft runout is greater than maximum, replace the shaft.

Maximum runout: 0.8 mm (0.031 in.)

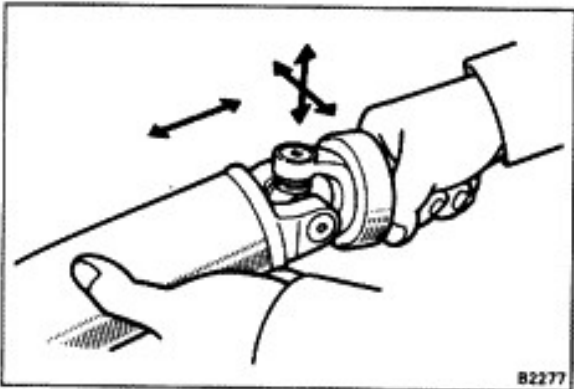

2. INSPECT SPIDER BEARINGS

(a) Inspect the spider bearings for wear or damage.

(b) Check the spider bearing axial play by turning the yoke while holding the shaft tightly.

Bearing axial play: 0 mm (0 in.)

If necessary, replace the propeller shaft.

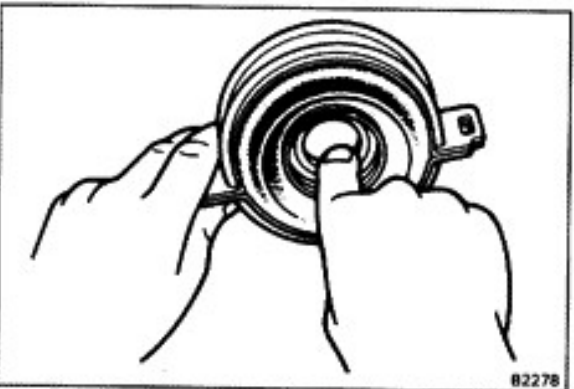

3. INSPECT CENTER SUPPORT BEARING FOR WEAR OR DAMAGE

Check that the bearing turns freely.

If the bearing is damaged, worn, or does not turn freely, replace it.

ASSEMBLY OF PROPELLER SHAFT

NOTE: If replacing either the center flange or intermediate shaft, reassemble them so that the front yoke of the intermediate shaft and the rear yoke of the propeller shaft are facing in the same direction shown in the figure below.

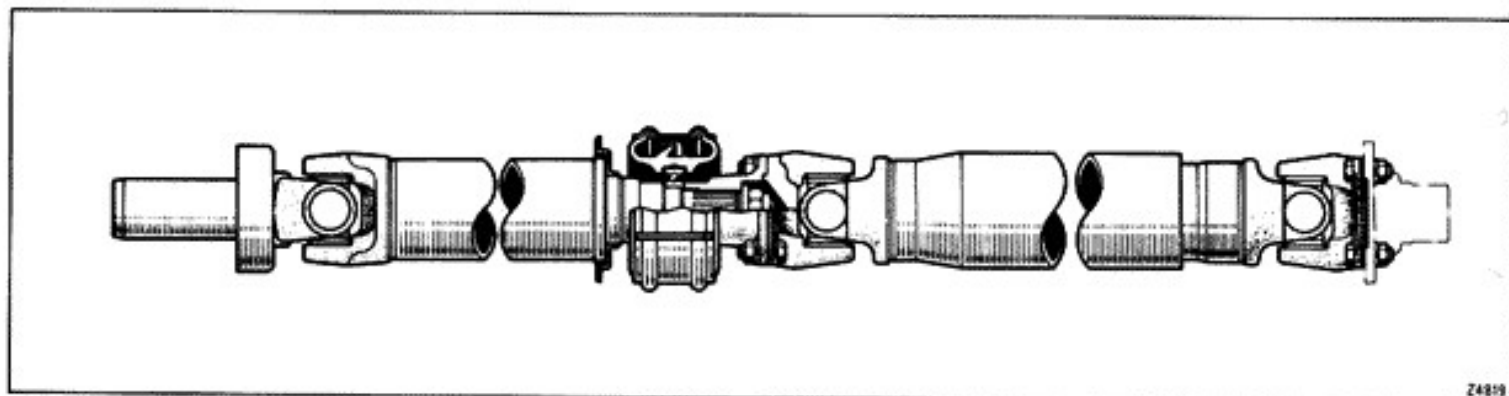

24819

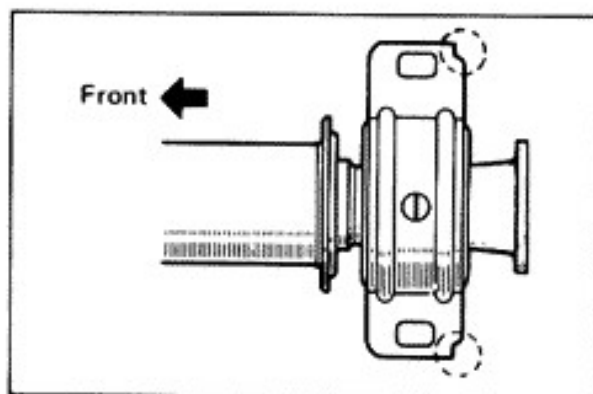

1. INSTALL CENTER SUPPORT BEARING ON INTERMEDIATE SHAFT

NOTE: Install the center support bearing with the cutout toward the rear.

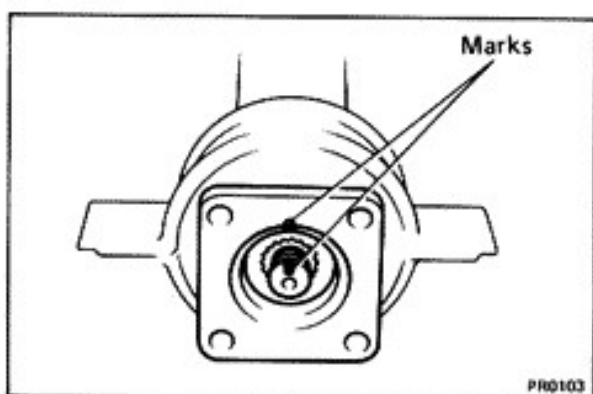

PR0103

2. INSTALL FLANGE ON INTERMEDIATE SHAFT

(a) Coat the splines of the intermediate shaft with MP grease.

(b) Align the matchmarks and install the flange to the intermediate shaft.

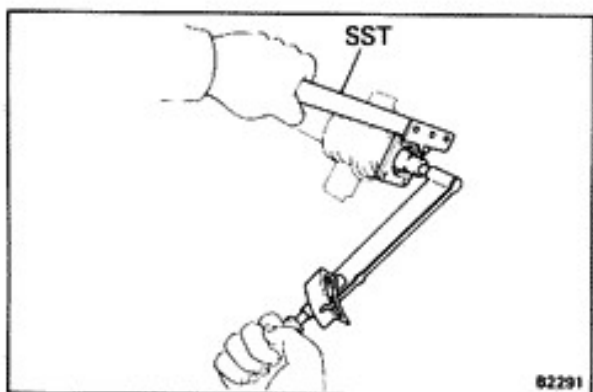

82291

(c) Using SST to hold the flange, press the bearing into position by tightening down a new nut.

SST 09330-00021

Torque: 1,850 kg-cm (134 ft-lb, 181 N·m)

(d) Loosen the nut.

(e) Torque the nut again.

Torque: 700 kg-cm (51 ft-lb, 69 N·m)

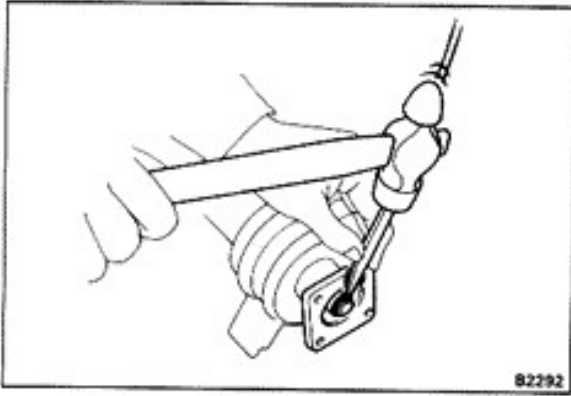

- (f) Using a hammer and punch, stake the nut.

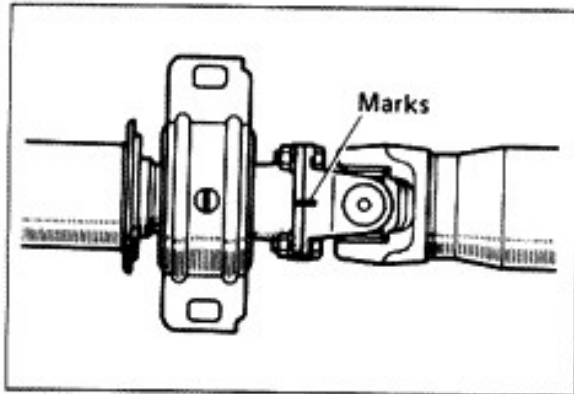

3. INSTALL PROPELLER SHAFT

- (a) Align the marks on the flanges and connect the flanges with four bolts and nuts.
(b) Torque the bolts and nuts.

Torque: 430 kg-cm (31 ft-lb, 42 N·m)

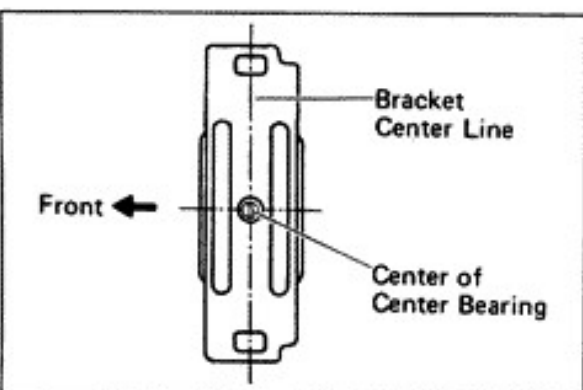
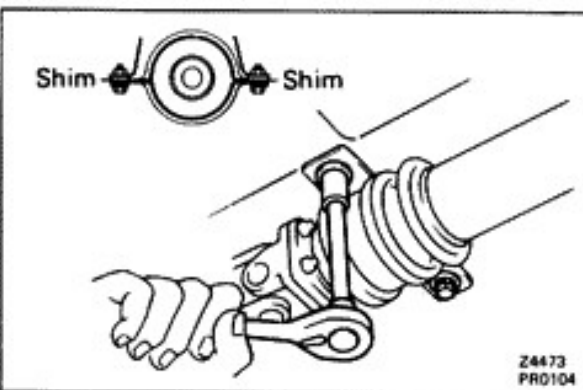
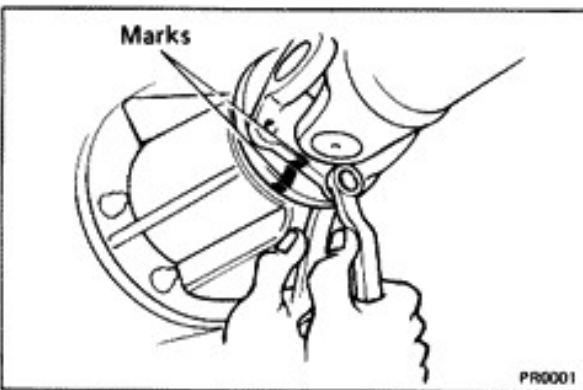
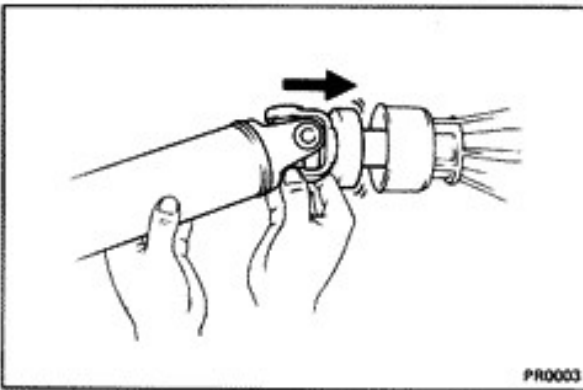
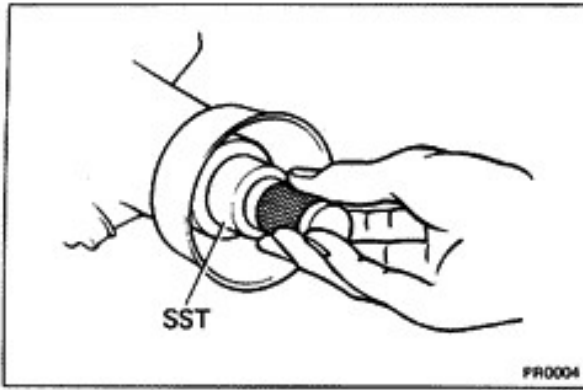

INSTALLATION OF PROPELLER SHAFT

(See page PR-3)

1. INSERT YOKE IN TRANSMISSION

- (a) Remove SST from the transmission.
SST 09325-20010

- (b) Push the yoke into the transmission.

2. CONNECT PROPELLER SHAFT FLANGE TO COMPANION FLANGE ON DIFFERENTIAL

- (a) Align the marks on the flanges and connect the flanges with four bolts and nuts.
(b) Torque the bolts and nuts.

Torque: 430 kg-cm (31 ft-lb, 42 N-m)

3. CONNECT CENTER SUPPORT BEARING TO BODY

- (a) Place a height spacer between the body and center support bearing, and install the two mounting bolts finger tight.

NOTE: Some vehicles do not have a spacer. In this case, it is not necessary to insert one.

- (b) Check that the bearing bracket is at right angle to the propeller shaft. Adjust the bracket if necessary.

- (c) Check that the center line of the center bearing is set to the center line of the bracket when the vehicle is in a no-load condition. Adjust the bracket if necessary.

- (d) Torque the mounting bolts.

Torque: 410 kg-cm (30 ft-lb, 40 N-m)