

TOYOTA

H41,H42,H50,H55F

TRANSMISSION

REPAIR MANUAL

Apr., 1982

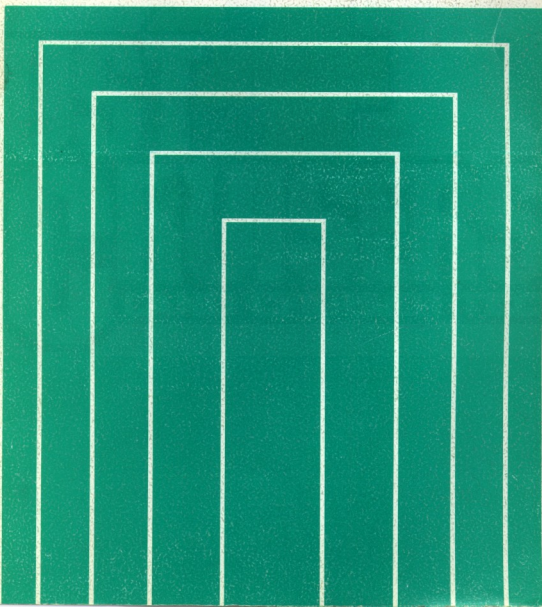

Pub. No. 36237E

FOREWORD

This repair manual has been prepared to provide information covering general service repairs for the H41, H42, H50 and H55F Manual Transmissions.

Applicable models:

BJ 40, 42, 43, 45, 46, 60 series
FJ 40, 43, 45, 60 series
HJ 47, 60 series
BU 20, 23, 25, 31, 32, 36, 40 series
HU 40, 50 series
WU 40, 50 series

All information contained in this manual is the most up-to-date at the time of publication. However specifications and procedures are subject to change without notice.

TOYOTA MOTOR CORPORATION

TOYOTA MANUAL TRANSMISSION H41, H42, H50, H55F REPAIR MANUAL

INTRODUCTION	IN
MANUAL TRANSMISSION	MT
TRANSFER	TF
SERVICE SPECIFICATIONS	A
STANDARD BOLT TIGHTENING TORQUE	B
SST	C

JAWHANI PART

INTRODUCTION

	Page
HOW TO USE THIS MANUAL	IN-2
GENERAL REPAIR INSTRUCTIONS	IN-4
ABBREVIATIONS USED IN THIS MANUAL	IN-5

IN

HOW TO USE THIS MANUAL

To assist in finding your way through the manual, the section title and major heading are given at the top of every page.

An **INDEX** is provided on the 1st page of each section to guide you to the item to be repaired.

At the beginning of each section, **PRECAUTIONS** are given that pertain to *all* repair operations contained in that section.

Read these precautions before starting any repair task.

REPAIR PROCEDURES

Most repair operations begin with an overview illustration. It identifies the components and shows how the parts fit together.

Example:

FJ HJ60, 4-Speed

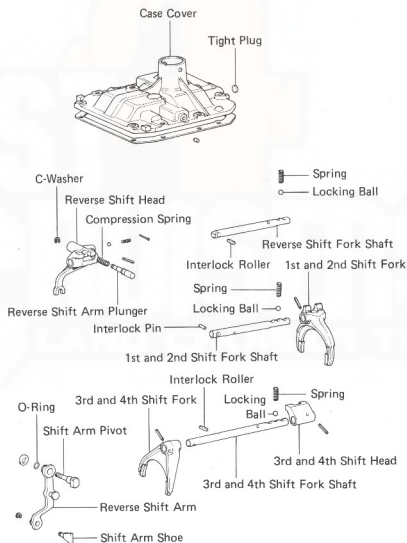

The procedures are presented in a step-by-step format:

- The illustration shows *what* to do and *where* to do it.
- The task heading tells *what* to do.
- The detailed text tells *how* to perform the task and gives other information such as specifications and warnings.

*Illustration:
what to do and where*

Example:

INSTALL FRONT BEARING WITH A GASKET

- Install the front bearing retainer with a gasket.
- Apply liquid sealer to the bolts. *Detail text:
how to do it*
- Install and torque the bolts.

Torque: 170 kg-cm (12 ft-lb, 17 N-m)

Specification

This format enables the experienced technician to have a **FAST TRACK**. He can read the task headings and only refer to the detailed text when he needs it. Important specifications and warnings always stand out in bold type.

REFERENCES

References have been kept to a minimum. However, when they are required you are given the *page* to go to.

SPECIFICATIONS

Specifications are presented in bold type throughout the text in the applicable step. You never have to leave the procedure to look up your specs. All specifications are also found in Appendix A, specifications for quick reference.

WARNINGS, CAUTIONS, NOTES:

- **WARNINGS** are presented in bold type, and indicate there is a possibility to injury to you or other people.
- **CAUTIONS** are also presented in bold type, and indicate there is a possibility of damage to the components being repaired.
- **NOTES** are separated from the text but do not appear in bold. They provide additional information to more efficiently help you perform the repair.

GENERAL REPAIR INSTRUCTIONS

1. Use fender seat and floor covers to keep the vehicle clean and prevent damage.
2. During disassembly, keep parts in order to facilitate re-assembly.
3. Observe the following:
 - (a) Before performing electrical work, disconnect the cable from the battery terminal.
 - (b) If it is necessary to disconnect the battery for inspection or repair, always disconnect the cable from the negative (-) terminal which is grounded to the vehicle body.
 - (c) To prevent damage to the battery terminal post, loosen the terminal nut and raise the cable straight up without twisting it or prying it.
 - (d) Clean the battery terminal posts and cable terminals with a shop rag. Do not scrape them with a file or such.
 - (e) Install the cable terminal to the battery post with the nut loose, and tighten the nut after installation. Do not use a hammer or such to tap the terminal onto the post.
 - (f) Be sure the cover for the positive (+) terminal is properly in place.
4. Check hose and wiring connectors to make sure that they are secure and correct.
5. Always replace cotter pins, gaskets and O-rings with new ones.
6. When necessary, use a sealer on gaskets to prevent leaks.
7. Carefully observe all specifications for bolt tightening torques. Always use a torque wrench.
8. Use of special service tool (SST) may be required, depending on the nature of the repair. Be sure to use SST where specified and follow the proper work procedure. A list of SST can be found at the back of this manual.
9. When replacing fuses, be sure the new fuse is the correct amperage rating. DO NOT exceed the fuse amp rating or use one of a lower rating.
10. Care must be taken when jacking up and supporting the vehicle. Be sure to lift and support the vehicle at the proper locations.
 - (a) If the vehicle is to be jacked up only at the front or rear end, be sure to block the wheels in order to ensure safety.
 - (b) After the vehicle is jacked up, be sure to support it on stands. It is extremely dangerous to do any work on the vehicle raised on jack alone, even for a small job that can be finished quickly.

ABBREVIATIONS USED IN THIS MANUAL

Ex.	Except
LH	Left-hand
LHD	Left-hand Drive
M/T	Manual Transmission
RH	Right-hand
RHD	Right-hand Drive
SST	Special Service Tool
STD	Standard
T/M	Transmission
w/	With
w/o	Without



MANUAL TRANSMISSION

	Page
H41, H42 and H55F TRANSMISSIONS	MT-2
Components	MT-2
Disassembly of Transmission	MT-7
Disassembly of Case Cover Assembly (4-Speed for BJ40, FJ40 Series)	MT-13
Disassembly of Case Cover Assembly (4-Speed for FJ60, HJ60 Series)	MT-15
Disassembly of Case Cover Assembly (5-Speed)	MT-17
Inspection of Transmission Components	MT-20
Assembly of Case Cover Assembly (4-Speed for BJ40, FJ40 Series)	MT-24
Assembly of Case Cover Assembly (4-Speed for FJ60, HJ60 Series)	MT-26
Assembly of Case Cover Assembly (5-Speed)	MT-28
Assembly of Transmission	MT-31
 H50 TRANSMISSION	 MT-40
Components	MT-40
Disassembly of Transmission	MT-43
Disassembly of Case Cover Assembly	MT-49
Inspection of Transmission Components	MT-52
Assembly of Case Cover Assembly	MT-56
Assembly of Transmission	MT-60
 REMOTE CONTROL (DYNA Floor Shift Series)	 MT-69
REMOTE CONTROL (DYNA Column Shift Series)	MT-72

MT

H41, H42 and H55F TRANSMISSIONS

COMPONENTS

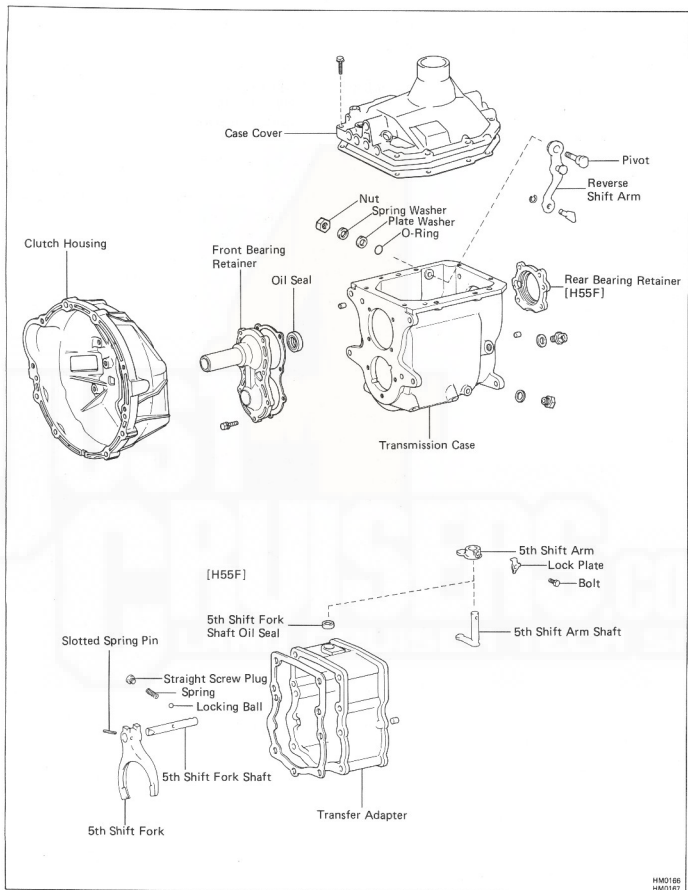

COMPONENTS (Cont'd)

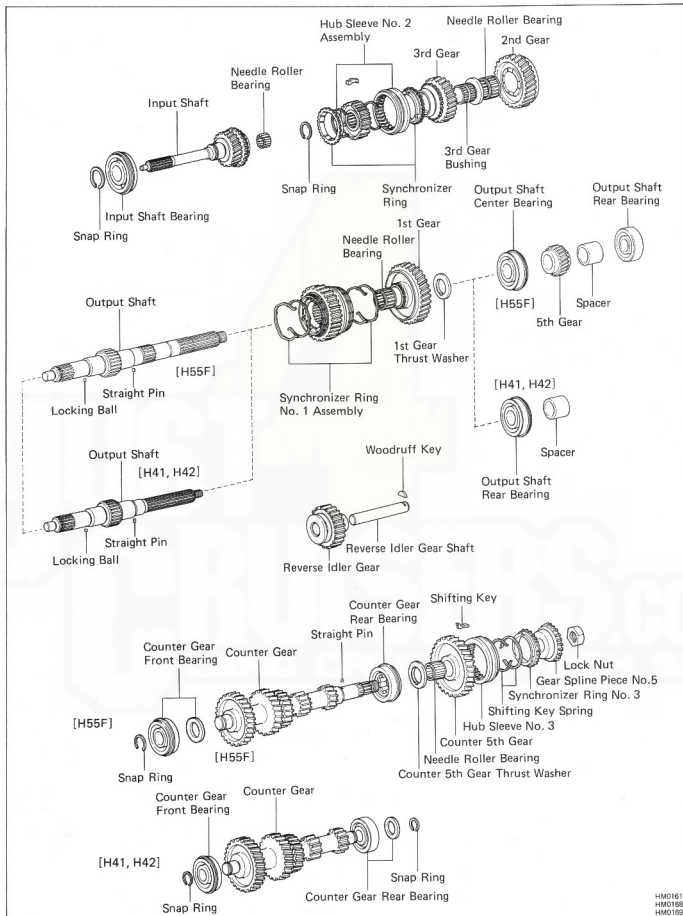

COMPONENTS (Cont'd)

FJ HJ 60, 4-Speed

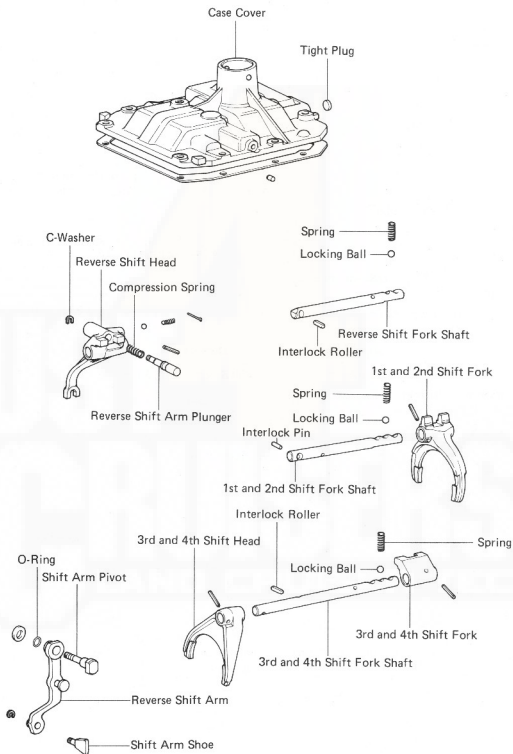

COMPONENTS (Cont'd)

5-Speed

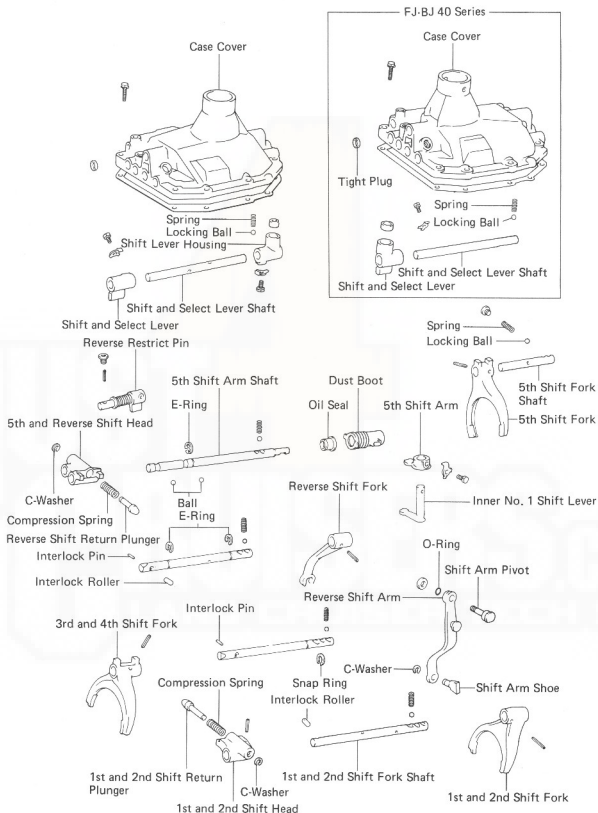

DISASSEMBLY OF TRANSMISSION

(See pages MT-2, 3)

1. REMOVE CLUTCH HOUSING (Ex. FJ model)
2. REMOVE TRANSFER
(See pages TF-4 to 9)

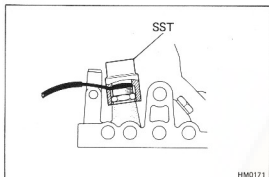

HM0171

3. REMOVE BACK-UP LIGHT SWITCH AND SHIFT POINT SENSOR SWITCH FROM CASE COVER

Using SST, remove the back-up light and shift point sensor switches.

SST 09817-16011

4. REMOVE CASE COVER

Remove case cover and gasket.

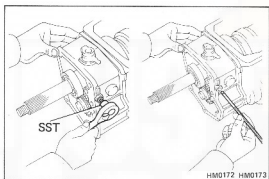

HM0172 HM0173

5. REMOVE FIFTH LOCKING BALL AND SPRING (H55F)

(a) Using SST, remove the screw plug.

SST 09313-30021

(b) Using a magnetic finger, remove the locking ball and spring.

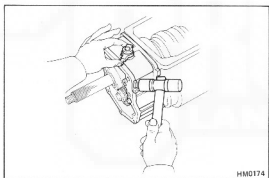

HM0174

6. REMOVE TRANSFER ADAPTER (H55F)

(a) Using a brass bar and hammer, carefully tap the transfer adapter.

(b) Pull up 5th shift arm and pull the transfer adapter from the transmission case.

7. MEASURE EACH GEAR THRUST CLEARANCE

Using a feeler gauge, measure the thrust clearance of each gear.

NOTE: For later reference, write down the thrust clearance.

Standard clearance:

1st and 2nd gears	0.175 – 0.325 mm (0.0069 – 0.0128 in.)
3rd gear	0.125 – 0.275 mm (0.0049 – 0.0108 in.)
Counter 5th gear	0.10 – 0.30 mm (0.0039 – 0.0118 in.)

Maximum clearance:

1st and 2nd gears	0.35 mm (0.0138 in.)
3rd and counter 5th gears	0.30 mm (0.0118 in.)

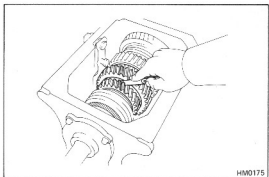

HM0175

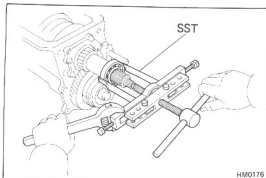
**8. REMOVE OUTPUT SHAFT REAR BEARING**

Using SST, remove the rear bearing.
SST 09950-20015

9. REMOVE SPACER**10. REMOVE LOCKING BALL (H41, 42)**

Using magnetic finger, remove the locking ball.

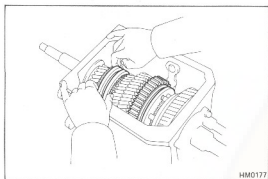
**11. REMOVE COUNTER GEAR REAR LOCK NUT (H55F)**

- (a) Engage the gear double meshing.
- (b) Unstake the lock nut.

(c) Using SST, remove the lock nut.

SST 09326-20011

(d) Disengage the gear double meshing.

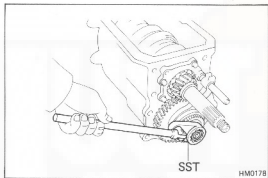
**12. REMOVE GEAR SPLINE PIECE NO. 5, COUNTER FIFTH GEAR ASSEMBLY AND FIFTH SHIFT FORK (H55F)**

Using SST, pull the counter 5th gear out of the counter gear rear end with gear spline piece No. 5 and the 5th shift fork.

SST 09213-27010

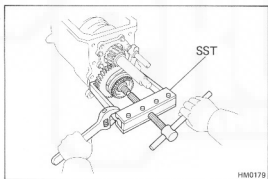
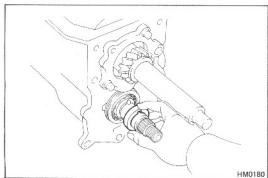
**13. REMOVE STRAIGHT PIN AND COUNTER FIFTH GEAR THRUST WASHER (H55F)**

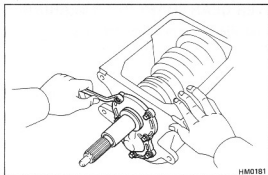
**14. REMOVE FRONT BEARING RETAINER**

NOTE: Be careful not to damage the oil seal.

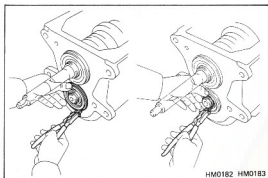
**15. REMOVE COUNTER GEAR FRONT BEARING**

(a) Using snap ring pliers, remove the snap rings.

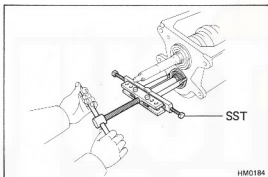

(b) Using SST, remove the counter gear front bearing.

SST 09950-20015

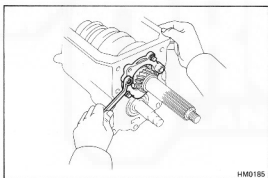
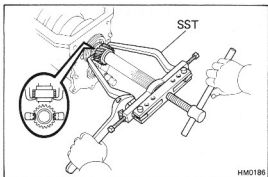
**16. REMOVE REAR BEARING RETAINER (H55F)****17. REMOVE FIFTH GEAR FROM OUTPUT SHAFT (H55F)**

Using SST, remove the 5th gear from the output shaft.

SST 09950-20015

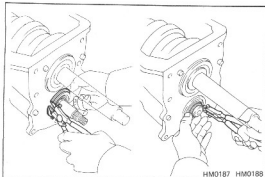
**18. REMOVE COUNTER GEAR SHAFT REAR BEARING**

- (a) Using snap ring pliers, remove the snap ring.

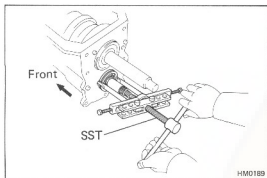

- (b) Using SST, remove the counter gear rear bearing.
SST 09950-20015

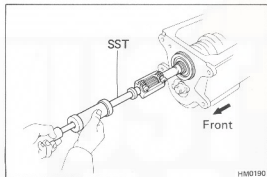
**19. REMOVE INPUT SHAFT AND BEARING**

- (a) Using SST, remove the input shaft and bearing.
SST 09910-00015

NOTE: Insure that the input shaft and counter gear do not strike against each other.

Be careful not to loose the 17 needle roller bearings.

- (b) Remove the synchronizer ring.

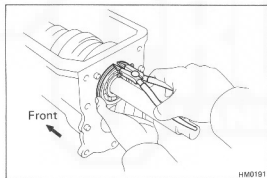
**20. REMOVE OUTPUT SHAFT CENTER BEARING FOR H55F OR OUTPUT SHAFT REAR BEARING FOR H41, 42**

- (a) Using snap ring pliers, remove the snap ring.

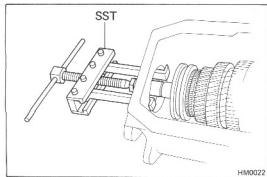

- (b) Using SST, support the output shaft front end.
SST 09213-27010

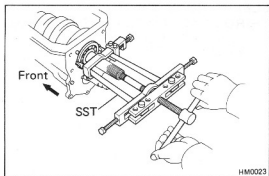

- (c) Using SST, remove the center bearing.
SST 09950-20015

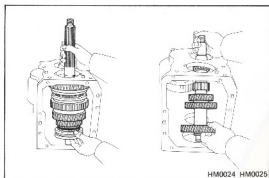

21. REMOVE OUTPUT SHAFT AND COUNTER GEAR

- (a) Stand the transmission case on its front end.
(b) Remove the output shaft.
(c) Remove the counter gear.

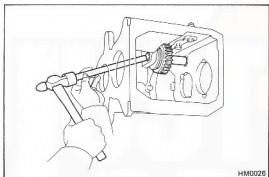

22. REMOVE REVERSE IDLER GEAR AND SHAFT

- (a) Tap out the reverse idler gear shaft toward the rear.
(b) Remove the gear and the woodruff key.

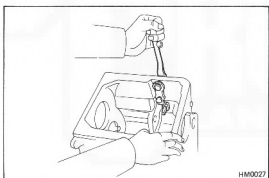

23. REMOVE REVERSE SHIFT ARM FROM TRANSMISSION CASE

Remove the nut, washers, O-ring, pivot arm, and reverse shift arm.

24. REMOVE FIRST GEAR THRUST WASHER, STRAIGHT PIN, FIRST GEAR AND NEEDLE ROLLER BEARING FROM OUTPUT SHAFT

25. REMOVE SYNCHRONIZER RING NO. 1 ASSEMBLY FROM OUTPUT SHAFT

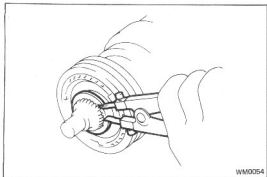

26. REMOVE HUB SLEEVE NO. 2 ASSEMBLY, SYNCHRONIZER RINGS, THIRD GEAR, THIRD GEAR BUSHING, NEEDLE ROLLER BEARING AND SECOND GEAR FROM OUTPUT SHAFT

(a) Using snap ring pliers, remove the snap ring.

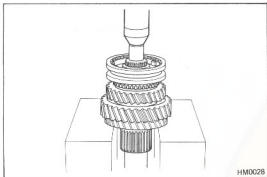

(b) Using a press, remove the hub sleeve No. 2 assembly, synchronizer ring, 3rd gear, 3rd gear bushing, needle roller bearing and 2nd gear.

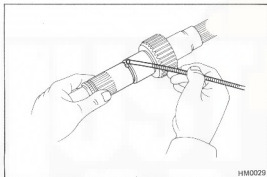

27. REMOVE LOCKING BALL

Using a magnetic finger, remove the locking ball.

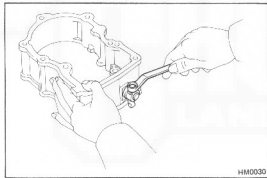

28. REMOVE FIFTH SHIFT ARM AND SHAFT FROM TRANSFER ADAPTER (H55F)

(a) Remove the bolt and lock washer.

(b) Remove the 5th shift arm and shaft.

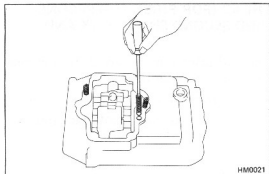

DISASSEMBLY OF CASE COVER ASSEMBLY (4-SPEED FOR BJ40, FJ40 SERIES)

(See page MT-4)

1. REMOVE SHIFT LEVER RETAINER

- (a) Remove the shift lever retainer.
- (b) Using a magnetic finger, remove the three locking balls and three springs.

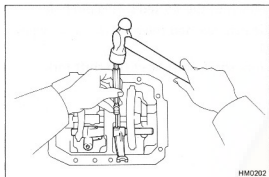

2. REMOVE SHIFT HEAD (FOR REVERSE GEAR) AND REVERSE SHIFT FORK

- (a) Using a pin punch, drive out the slotted spring pins from the shift head and shift fork.

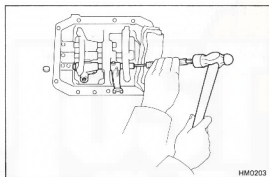

- (b) Using a pin punch, drive out the shift fork shaft together with the tight plug.

- (c) Remove the fork shaft, shift fork, shift head and interlock roller.

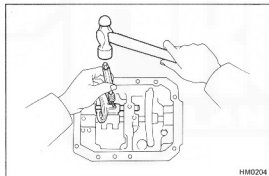

3. REMOVE SHIFT FORK (FOR THIRD AND FOURTH GEARS) AND SHAFT

- (a) Using a pin punch, drive out the slotted spring pins from the shift fork.

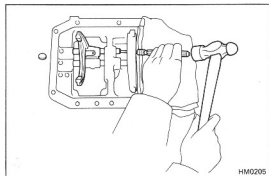

- (b) Using a pin punch, drive out the shift fork shaft together with the tight plug.

- (c) Remove the shift fork shaft, shift fork and interlock roller.

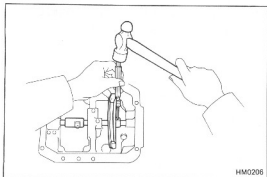

4. REMOVE SHIFT HEAD (FOR FIRST AND SECOND GEARS), FIRST AND SECOND SHIFT FORK AND SHAFT

- (a) Using a pin punch, drive out the slotted spring pins from the shift head and the shift fork.
- (b) Slide the shift fork toward the rear.
- (c) Using a magnetic finger, remove the interlock pin.

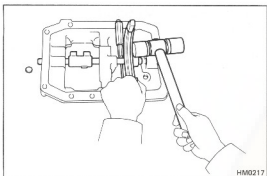

- (d) Install a pin punch to the slotted spring pin hole.
- (e) Using a plastic hammer, tap the shift fork and remove the tight plug.
- (f) Remove the fork shaft, shift head and shift fork.

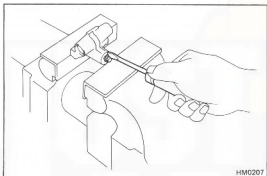

5. DISASSEMBLE SHIFT HEAD

- (a) Compress the spring and remove the snap ring.

CAUTION: Be careful as the plunger will spring out.

- (b) Remove the plunger and compression spring.

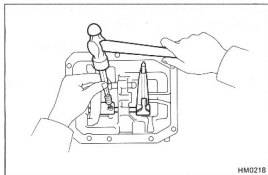

DISASSEMBLY OF CASE COVER ASSEMBLY (4-SPEED FOR FJ60, HJ60 SERIES)

(See page MT-5)

1. REMOVE SHIFT HEAD (FOR THIRD AND FOURTH GEARS), THIRD AND FOURTH SHIFT FORK AND SHAFT

- (a) Using a pin punch, drive out the slotted spring pins from the shift head and the shift fork.

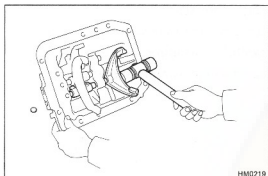

- (b) Using a hammer, drive out the shift fork shaft together with the tight plug.

NOTE: Cover the service hole with your hand to prevent the locking ball from flying out.

- (c) Remove the fork shaft, shift head, interlock roller, locking ball and spring.

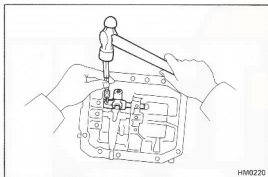

2. REMOVE REVERSE SHIFT HEAD

- (a) Using a pin punch and a hammer, drive out the slotted spring pin from the reverse shift head.

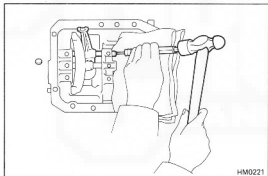

- (b) Using a pin punch and a hammer, drive out the shift fork shaft together with the tight plug.

NOTE: Cover the service hole with your hand to prevent the locking ball from flying out.

- (c) Remove the fork shaft, shift head, interlock roller, locking ball and spring.

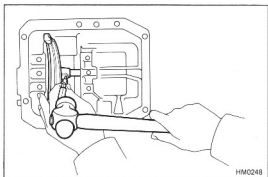

3. REMOVE FIRST AND SECOND SHIFT FORK AND SHAFT

- (a) Using a pin punch and a hammer, remove the slotted spring pin from the shift fork.

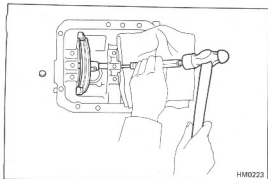

- (b) Using a pin punch and a hammer, drive out the shift fork shaft together with the tight plug.

NOTE: Cover the service hole with your hand to prevent the locking ball from flying out.

- (c) Remove the fork shaft, shift fork, interlock pin, locking ball and spring.

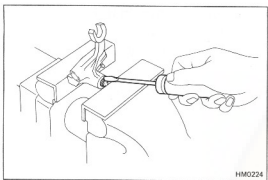

4. DISASSEMBLE SHIFT HEAD

- (a) Compress the spring, and remove the snap ring.

CAUTION: Be careful as the plunger will spring out.

- (b) Remove the plunger and compression spring.

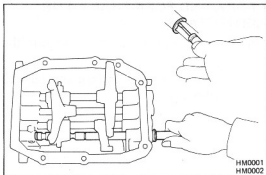

DISASSEMBLY OF CASE COVER ASSEMBLY (5-SPEED)

(See page MT-6)

1. REMOVE FIFTH FORK SHAFT

- (a) Using a screwdriver, pry out the E-ring.
- (b) Remove the fork shaft, two interlock balls, locking ball and spring.

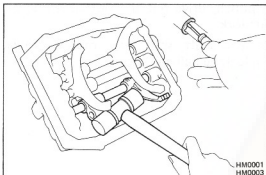

2. REMOVE SHIFT HEAD (FOR REVERSE AND FIFTH GEARS), REVERSE SHIFT FORK AND FORK SHAFT

- (a) Using a screwdriver, pry out the E-rings.
- (b) Using a plastic hammer, tap on the shift fork and remove the tight plug from the case cover.

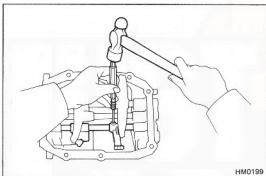

- (c) Using a pin punch, drive out the slotted spring pin from the shift fork.
- (d) Remove the fork shaft, shift fork, shift head, interlock roller, interlock pin, locking ball and spring.

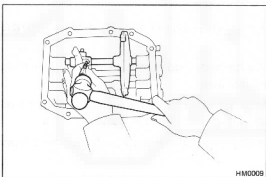

3. REMOVE SHIFT HEAD, SHIFT FORK AND FORK SHAFT (FOR FIRST AND SECOND GEARS)

- (a) Using a pin punch, drive out the slotted spring pin from the shift head.

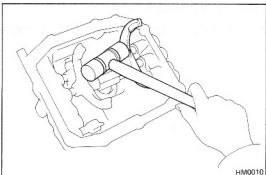

- (b) Using a plastic hammer, tap the shift fork and remove the tight plug from the case cover.
- (c) Using a pin punch, drive out the slotted spring pin from the shift fork.
- (d) Remove the fork shaft, shift head, shift fork, locking ball and spring.

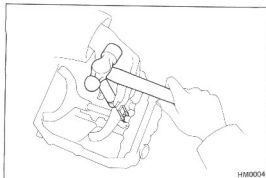

4. REMOVE SHIFT FORK AND FORK SHAFT (FOR THIRD AND FOURTH GEARS)

- (a) Using two screwdrivers and a hammer, tap out the snap ring.
- (b) Using a plastic hammer, tap the shift fork and remove the tight plug from the case cover.
- (c) Using a pin punch, drive out the slotted spring pin from the shift fork.
- (d) Remove the fork shaft, shift fork, interlock roller, interlock pin, locking ball and spring.

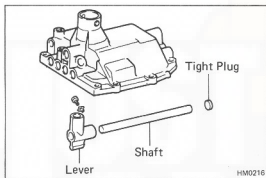
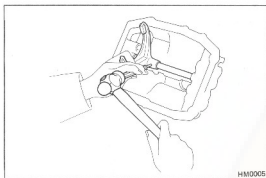

5-1 (40 SERIES)

REMOVE SELECT LEVER AND SHAFT

- (a) Using a plastic hammer, tap the select lever and remove the tight plug from the case cover.
- (b) Unstake the lock plate and remove the lock bolt.
- (c) Remove the shaft and select lever.

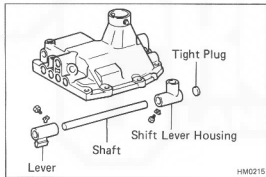

5-2 (60 SERIES)

REMOVE SELECT LEVER, SHAFT AND SHIFT LEVER HOUSING

- (a) Unstake the lock plate and remove the lock bolt from the shift lever housing.
- (b) Using a plastic hammer, tap the select lever and remove the tight plug from the case cover.
- (c) Unstake the lock plate and remove the lock bolt from the lever.
- (d) Remove the shaft, select lever and shift lever housing.

6. REMOVE REVERSE RESTRICT PIN

- (a) Using a hexagon wrench, remove the straight screw plug.

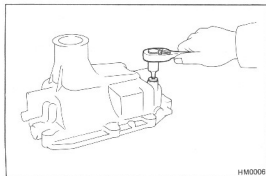

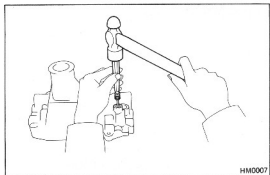

- (b) Using a pin punch, drive out the slotted spring pin.
- (c) Remove the restrict pin.

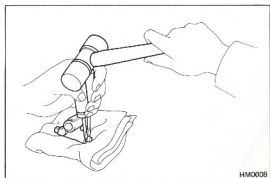

7. DISASSEMBLE SHIFT HEADS

- (a) Using two screwdrivers and a hammer, remove the C-washer.

CAUTION: Be careful as the plunger will spring out.

- (b) Remove the plunger and compression spring.

NOTE: Be careful not to mix up the springs and plungers.

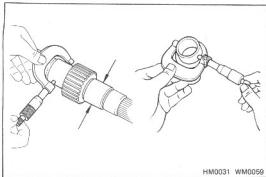

HM0031 WM0059

INSPECTION OF TRANSMISSION COMPONENTS

1. INSPECT OUTPUT SHAFT AND BUSHING

- Check the output shaft and bushing for wear or damage.
- Using a micrometer, measure the outer diameter of the output shaft journal and bushing.

Minimum diameter

1st and 2nd gear journal	43.93 mm (1.7295 in.)
Bushing	47.91 mm (1.8862 in.)

- Using a dial indicator, measure the shaft runout.

Maximum runout: 0.03 mm (0.0012 in.)

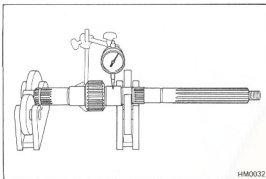

HM0032

2. INSPECT COUNTER GEAR AND BEARINGS

- Check the gear teeth for wear or damage.
- Check the bearings for wear or damage.
- Using a micrometer, measure the outer diameter of the counter gear journal. (H55F only)

Maximum diameter:

Counter 5th gear journal	31.93 mm (1.2571 in.)
Rear bearing journal	39.90 mm (1.5709 in.)

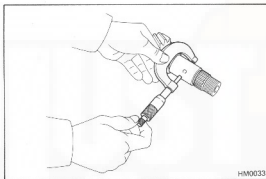

HM0033

3. IF NECESSARY, REPLACE REAR BEARING INNER RACE (H41, H42 only)

- Using SST, remove the bearing inner race.

SST 09602-10010

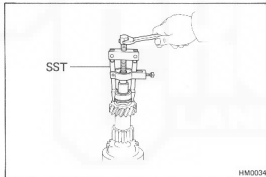

HM0034

- Using SST and a press, install the bearing inner race.

SST 09515-21010

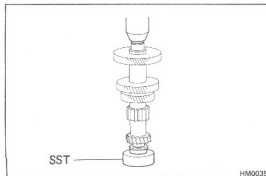

HM0035

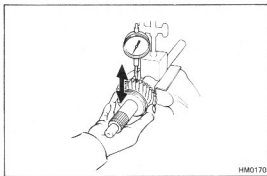

HM0170

4. INSPECT OIL CLEARANCE OF FIRST, SECOND AND COUNTER FIFTH GEARS

Using a dial indicator, measure the oil clearance between the gear and shaft with the needle roller bearing installed.

Standard clearance:

1st and 2nd gears	0.020 — 0.073 mm (0.0008 — 0.0029 in.)
Counter 5th gear	0.015 — 0.068 mm (0.0006 — 0.0027 in.)

Maximum clearance:

1st and 2nd gears	0.08 mm (0.0031 in.)
Counter 5th gear	0.07 mm (0.0028 in.)

5. INSPECT OIL CLEARANCE OF THIRD GEAR

Using a dial indicator, measure the oil clearance between the gear and bushing.

Standard clearance: 0.065 — 0.115 mm
(0.0026 — 0.0045 in.)

Maximum clearance: 0.12 mm (0.0047 in.)

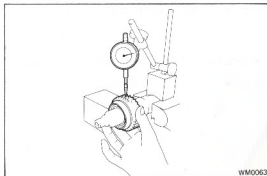

WM0063

6. INSPECT SYNCHRONIZER RINGS OF FIRST AND SECOND GEARS

- Check the inner spline for wear or damage.
- Check the raised position of the guide pins for wear or damage.
- Check the thrust pieces and gear moving parts for wear or damage.
- Check the guide pin rivet staked parts for play or damage.
- Check the synchronizer ring holders for deterioration or wear.
- With the synchronizer ring pressed into the gear, measure the distance as shown.

Minimum distance:

1st gear	32.5 mm (1.280 in.)
2nd gear	38.0 mm (1.496 in.)

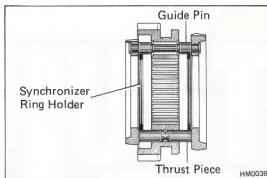

HM0036

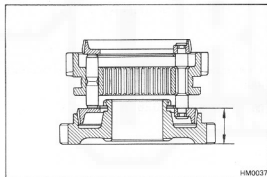

HM0037

7. INSPECT SYNCHRONIZER RINGS OF THIRD GEAR, INPUT SHAFT AND GEAR SPLINE PIECE NO. 5 (H55F only)

- Check the synchronizer rings for wear or damage.
- Turn the ring and push it in to check the braking action.
- Measure the clearance between the synchronizer ring back and gear spline end.

Minimum clearance: 0.8 mm (0.031 in.)

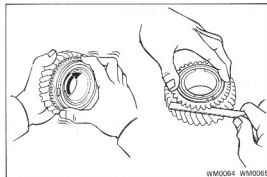

WM0064 WM0065

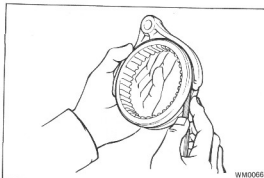

8. INSPECT SHIFT FORKS AND HUB SLEEVES

- (a) Check the contact surfaces for wear or damage.
- (b) Measure the clearance between the hub sleeve and the shift fork.

Maximum clearance: 0.8 mm (0.031 in.)

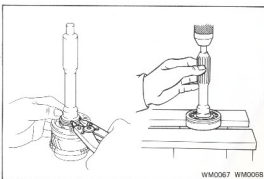

9. INSPECT INPUT SHAFT AND BEARING

Check for wear or damage.

10. IF NECESSARY, REPLACE INPUT SHAFT BEARING

- (a) Using snap ring pliers, remove the snap ring.
- (b) Using a press, remove the bearing.

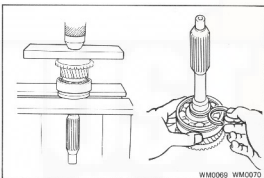

- (c) Using a press, install the bearing.

CAUTION: Do not press in the bearing outer race.

- (d) Select a snap ring that will allow minimum axial play and install it on the shaft.

Standard play: 0 – 0.10 mm (0 – 0.0039 in.)

Part No.	Thickness mm (in.)
90520 – 36016	3.20 – 3.31 (0.1260 – 0.1303)
90520 – 36015	3.31 – 3.42 (0.1303 – 0.1346)

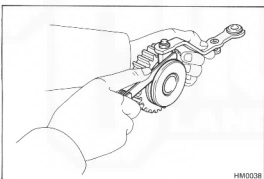

11. INSPECT REVERSE SHIFT ARM AND REVERSE IDLER GEAR

- (a) Check for wear or damage.
- (b) Measure the clearance between the shift arm shoe and idler gear groove.

Maximum clearance: 0.7 mm (0.028 in.)

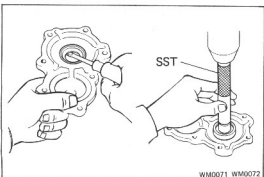

12. INSPECT FRONT BEARING RETAINER

- (a) Check for wear or damage.
- (b) Check the oil seal for wear or damage.

13. IF NECESSARY, REPLACE FRONT BEARING RETAINER OIL SEAL

- (a) Using a screwdriver, pry out the oil seal.
- (b) Using SST, press in a new oil seal.

SST 09950-20015

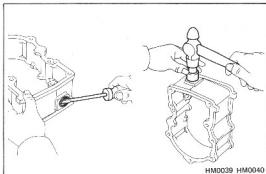

**14. INSPECT TRANSFER ADAPTER
(H55F only)**

- (a) Check for damage.
- (b) Check the oil seal for wear or damage.

**15. IF NECESSARY, REPLACE FIFTH SHIFT ARM OIL
SEAL ON TRANSFER ADAPTER
(H55F only)**

- (a) Using a screwdriver, pry out the oil seal.
- (b) Using a socket wrench and hammer, drive in a new oil seal.

Drive in depth: 1.0 mm (0.039 in.)

**16. IF NECESSARY, REPLACE FIFTH FORK SHAFT OIL
SEAL ON CASE COVER
(H55F only)**

- (a) Using a screwdriver, pry out the oil seal.
- (b) Using SST, drive in a new oil seal.

SST 09304-47010

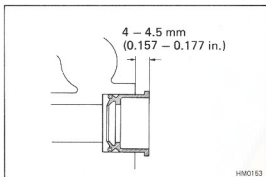

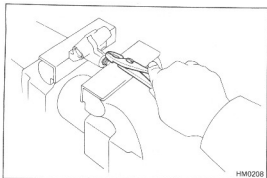

ASSEMBLY OF CASE COVER ASSEMBLY (4-SPEED FOR BJ40, FJ40 SERIES)

(See page MT-3)

1. ASSEMBLE SHIFT HEAD

- Install the compression spring and plunger into the shift head.
- Press the end of the plunger, and install a new snap ring.

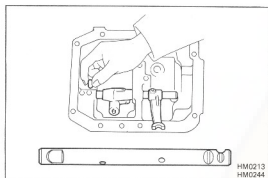

2. INSTALL SHIFT HEAD (FOR REVERSE GEAR) AND REVERSE SHIFT FORK

- Insert the fork shaft through the shift head and fork.
- Install the interlock roller in the case cover.

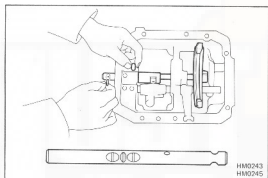

3. INSTALL SHIFT HEAD (FOR FIRST AND SECOND GEARS), FIRST AND SECOND SHIFT FORK AND SHAFT

- Coat the interlock pin with MP grease and install it in the shaft.

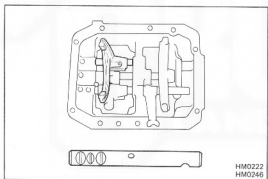

- Insert the fork shaft into the case cover through the shift head and fork.
- Install interlock roller in the case cover.

4. INSTALL SHIFT FORK (FOR THIRD AND FOURTH GEARS) AND SHAFT

Insert the fork shaft into the case cover through the shift fork.

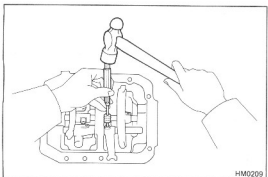

5. INSTALL SLOTTED SPRING PINS

- Align the pin hole of each shaft with the fork, head and the other fork respectively.
- Using a pin punch, drive in the slotted spring pins until they are flush with the fork.

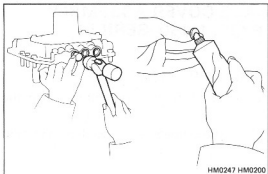

HM0247 HM0200

6. INSTALL TIGHT PLUGS

Apply liquid sealer to the tight plugs and drive them into the case cover as shown.

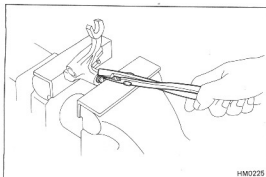

ASSEMBLY OF CASE COVER ASSEMBLY (4-SPEED FOR FJ60, HJ60 SERIES)

(See page MT-5)

1. ASSEMBLE REVERSE SHIFT HEAD

- (a) Install the compression spring and plunger into the shift head.
- (b) Press the end of the plunger, and install a new snap ring.

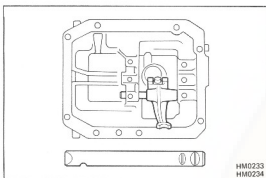

2. INSTALL REVERSE SHIFT HEAD AND SHAFT

- (a) Install the spring and locking ball.
- (b) Insert the fork shaft through the reverse shift head.

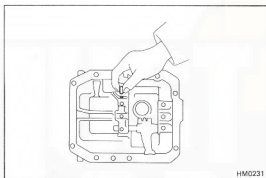

3. INSTALL FIRST AND SECOND SHIFT FORK AND SHAFT

- (a) Install the spring and locking ball.
- (b) Coat the interlock pin with MP grease and install it in the shaft.

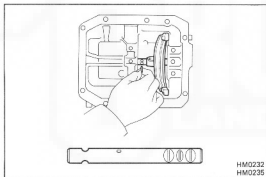

- (c) Insert the fork shaft through the shift fork.

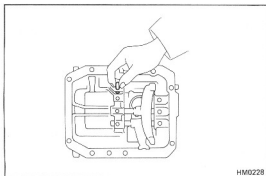

4. INSTALL THIRD AND FOURTH SHIFT FORK AND SHAFT

- (a) Install the spring and locking ball.
- (b) Coat the interlock roller with MP grease and install it in the case cover.

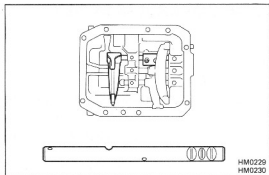

- (c) Insert the fork shaft through the 3rd and 4th shift fork.

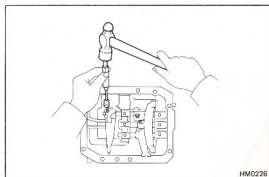

5. INSTALL SLOTTED SPRING PINS

- (a) Align the pin hole of each shaft with the fork, head and the other fork respectively.
(b) Using a pin punch, drive in the slotted spring pins until they are flush with the fork.

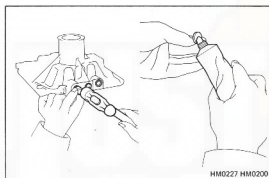

6. INSTALL TIGHT PLUGS

Apply liquid sealer to the tight plugs and drive them into the case cover as shown.

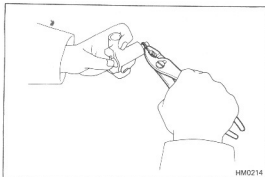

ASSEMBLY OF CASE COVER ASSEMBLY (5-SPEED)

(See page MT-5)

1. ASSEMBLE SHIFT HEADS

- (a) Install the compression spring and plunger into the shift head.
- (b) Press the end of the plunger, and install a new snap ring.

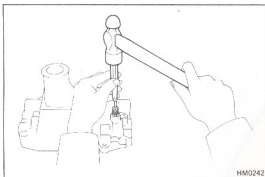

2. INSTALL REVERSE RESTRICT PIN

- (a) Insert the reverse restrict pin into the case cover.
- (b) Align the pin holes of the case cover and pin, and drive in the slotted spring pin.

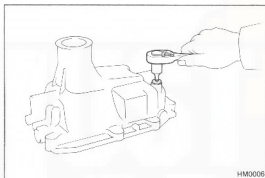

- (c) Apply liquid sealer to the plug and torque the plug.

Torque: 190 kg-cm (14 ft-lb, 19 N-m)

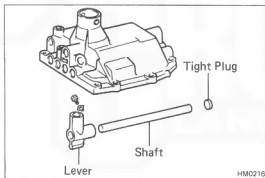

3-1 (40 SERIES)

INSTALL SELECT LEVER AND SHAFT

- (a) Insert the shaft through the select lever.
- (b) Align the holes of the shaft and select lever, and install the lock bolt with a new lock plate.
- (c) Stake the lock plate.

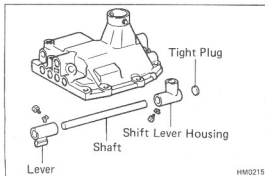

3-2 (60 SERIES)

INSTALL SELECT LEVER, SHAFT AND SHIFT LEVER HOUSING

- (a) Insert the shaft through the select lever and shift lever housing.
- (b) Align the holes of the shaft and select lever, and install the lock bolt with a new lock plate.
- (c) Align the holes of the shaft and shift lever housing, and install the lock bolt with a new lock plate.
- (d) Stake the lock plates.

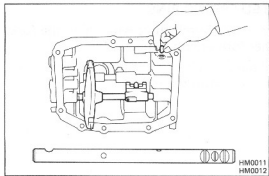

4. INSTALL SHIFT HEAD, SHIFT FORK AND FORK SHAFT (FOR FIRST AND SECOND GEARS)

- (a) Install the spring and locking ball.
- (b) Insert the fork shaft through the shift fork and shift head.
- (c) Install the interlock roller to the case cover.

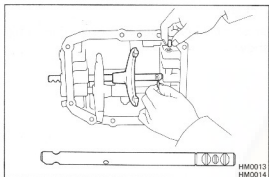

5. INSTALL SHIFT FORK AND FORK SHAFT (FOR THIRD AND FOURTH GEARS)

- (a) Install the spring and locking ball.
- (b) Coat the interlock pin with MP grease and install it in the shaft.
- (c) Insert the fork shaft through the shift fork.
- (d) Install the roller to the case cover.

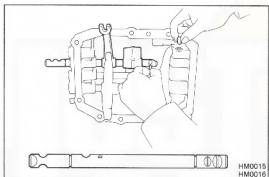

6. INSTALL SHIFT HEAD (FOR REVERSE AND FIFTH GEARS), REVERSE SHIFT FORK AND FORK SHAFT

- (a) Install the spring and locking ball.
- (b) Coat the interlock pin with MP grease and install it in the shaft.
- (c) Insert the fork shaft through the shift fork and the shift head.
- (d) Install the two interlock balls to the case cover and shift head.

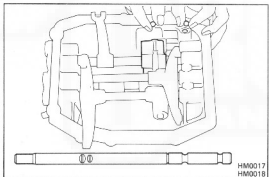

7. INSTALL FIFTH FORK SHAFT

- (a) Install the spring and locking ball.
- (b) Insert the fork shaft through the shift head.

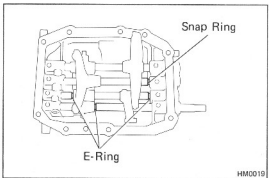

8. INSTALL THREE E-RINGS AND SNAP RING

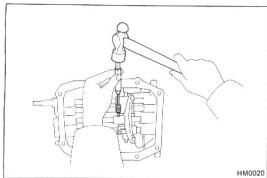
**9. INSTALL SLOTTED SPRING PINS**

- (a) Align the pin hole of each shaft with either the fork, head and other fork or arm respectively.
- (b) Using a pin punch, drive in the slotted spring pins until they are flush with the fork.

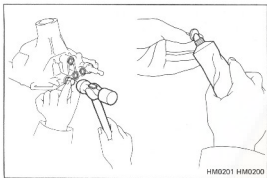
**10. INSTALL TIGHT PLUGS**

Apply liquid sealer to the tight plugs and drive them into the case cover as shown.

ASSEMBLY OF TRANSMISSION

(See pages MT-2, 3)

1. INSTALL SECOND GEAR AND NEEDLE ROLLER BEARING

- (a) Apply gear oil to the output shaft.
- (b) Install the needle roller bearing and 2nd gear.

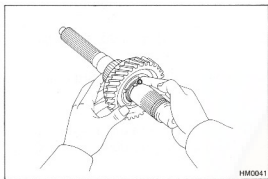
**2. INSTALL LOCKING BALL, BUSHING AND THIRD GEAR**

- (a) Install the locking ball in the shaft.

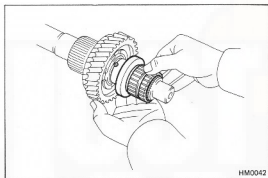

- (b) Install the bushing on the output shaft and align the bushing notch and locking ball.

- (c) Apply gear oil to the bushing.

- (d) Install the 3rd gear on the bushing.

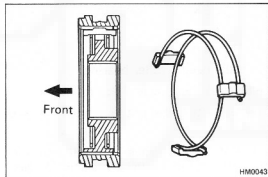
**3. INSERT CLUTCH HUB NO.2 INTO HUB SLEEVE**

- (a) Install the clutch hub and shifting keys to the hub sleeve.

- (b) Install the shifting key springs under the shifting keys.

CAUTION: Install the key springs positioned so that their ends are not in line.

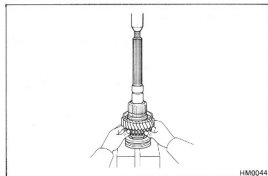
**4. INSTALL HUB SLEEVE NO. 2 ASSEMBLY**

Using a press, install the hub sleeve No. 2 assembly.

CAUTION: Hold the 3rd gear to prevent the bushing from falling. Be sure that the shifting keys align with the synchronizer ring slots.

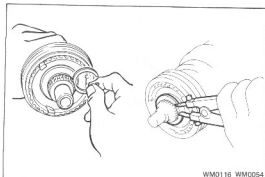

5. INSTALL SNAP RING

Select a snap ring that will allow minimum axial play and install it on the shaft.

Mark	Thickness	mm (in.)
0	2.40 – 2.45	(0.0945 – 0.0965)
1	2.45 – 2.50	(0.0965 – 0.0984)
2	2.50 – 2.55	(0.0984 – 0.1004)
3	2.55 – 2.60	(0.1004 – 0.1024)
4	2.60 – 2.65	(0.1024 – 0.1043)
5	2.65 – 2.70	(0.1043 – 0.1063)

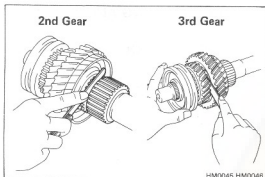

6. MEASURE SECOND AND THIRD GEARS THRUST CLEARANCE

Using a feeler gauge, measure the 2nd and 3rd gear thrust clearances.

Standard clearance:

2nd gear	0.175 – 0.325 mm (0.0069 – 0.0128 in.)
3rd gear	0.125 – 0.275 mm (0.0049 – 0.0108 in.)

Maximum clearance:

2nd gear	0.35 mm (0.0138 in.)
3rd gear	0.30 mm (0.0118 in.)

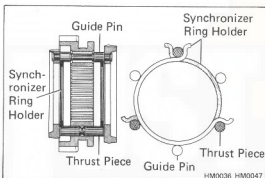

7. ASSEMBLE SYNCHRONIZER RING HOLDER

Hook the synchronizer ring holder ends to the thrust piece.

NOTE:

- Align the synchronizer ring holder ends so they are not both facing in the same direction.
- So sure that the synchronizer ring holders are parallel and not intersecting.

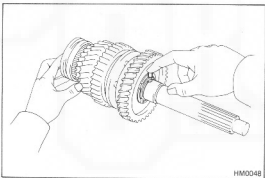

8. INSTALL SYNCHRONIZER RING NO. 1 AND FIRST GEAR

- Install synchronizer ring No. 1.
- Apply gear oil to the needle roller bearing.
- Install the needle roller bearing and the 1st gear.
- Apply MP grease to the straight pin and 1st gear thrust washer.
- Install the 1st gear thrust washer onto the output shaft with the straight pin aligned with the 1st gear thrust washer.

9. INSTALL REVERSE SHIFT ARM

- Install the reverse shift arm so its pivot is positioned as shown.
- Install the O-ring, plate washer, spring washer and nut.

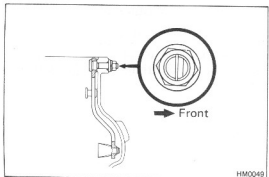

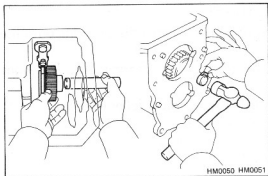
**10. INSTALL REVERSE IDLER GEAR AND SHAFT**

- Align the reverse idler gear groove with the reverse shift arm shoe.
- Install the reverse idler gear shaft with the woodruff key through the gear.

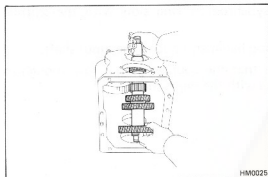
**11. PUT COUNTER GEAR INTO TRANSMISSION CASE**

- Stand the transmission case on its front end.
- Put the counter gear into the case.

CAUTION: Be careful not to damage either end.

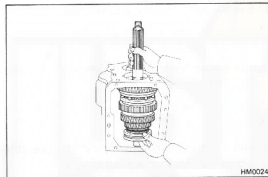
**12. PUT OUTPUT SHAFT ASSEMBLY INTO TRANSMISSION CASE**

CAUTION: Be careful not to damage the front end of the shaft.

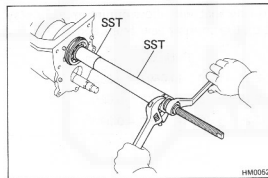
**13. INSTALL OUTPUT SHAFT CENTER BEARING FOR H55F OR OUTPUT SHAFT REAR BEARING FOR H41, 42**

- Using snap ring pliers, install the snap ring onto the bearing.
- Confirm that the groove of the 1st gear thrust washer and the straight pin are aligned.
- Using SST, install the bearing until it comes into contact with the 1st gear thrust washer.

SST 09309-36032 and 09309-60010
(H55F only)

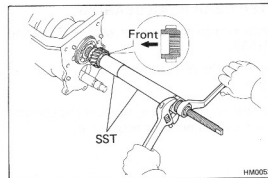
**14. INSTALL FIFTH GEAR TO OUTPUT SHAFT (H55F)**

- Apply MP grease to the inside surface of the 5th gear.
- Using SST, install the 5th gear to the output shaft.

SST 09309-36032 and 09309-60010

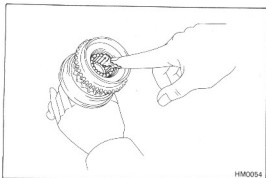

15. INSTALL INPUT SHAFT

- Using a snap ring pliers, install the snap ring onto the bearing.
- Install the 17 needle roller bearings into the input shaft.
- Apply MP grease to the needle roller bearings.

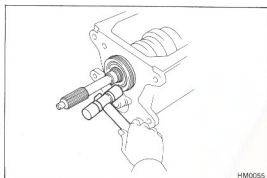

- Align the synchronizer ring slots with the shifting keys.
- Using a plastic hammer, drive in the input shaft.

NOTE: Be sure that the counter gear is low enough so as not to interfere with the input shaft.

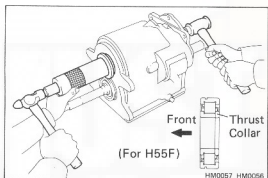

16. INSTALL COUNTER GEAR FRONT BEARING

- Turn the transmission over and align the counter gear center.
- Install the thrust collar for the front bearing onto the counter gear. (H55F)
- Using SST, drive in the bearing.

SST 09316-60010

NOTE: When driving in the bearing, support the counter gear in rear with a 3-5 lb hammer or equivalent.

- Install the snap ring onto the bearing outer race.
- Install a snap ring that will allow minimum axial play and install it on the counter gear front end.

Mark	Thickness	mm (in.)
0	2.05 – 2.10	(0.0807 – 0.0827)
2	2.15 – 2.20	(0.0846 – 0.0866)
4	2.25 – 2.30	(0.0886 – 0.0906)

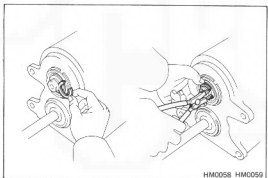

17. INSTALL COUNTER GEAR REAR BEARING

- Install the snap ring to the counter gear rear bearing outer race. (H55F)
- Using SST, drive in the rear bearing.

SST 09316-60010

NOTE: When driving in the bearing, support the counter gear in front with a 3-5 lb hammer or equivalent.

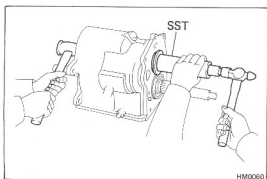

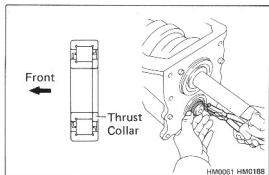

- (c) Install the thrust collar for the rear bearing onto the counter gear rear end. (H41, 42)
- (d) Using snap ring pliers, install the snap ring onto the counter gear rear end. (H41, 42)

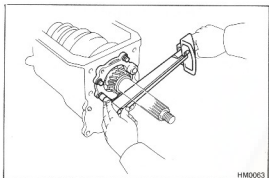

18. INSTALL REAR BEARING RETAINER (H55F)

Install the rear bearing retainer to the transmission case. Torque the bolts.

Torque: 185 kg-cm (13 ft-lb, 18 N-m)

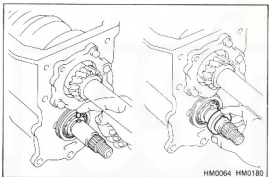

19. INSTALL STRAIGHT PIN AND COUNTER FIFTH GEAR THRUST WASHER (H55F)

- (a) Install the straight pin onto the counter shaft.
- (b) Align the thrust washer slot with the straight pin, and install the thrust washer.

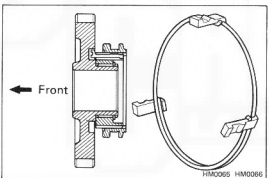

20. ASSEMBLE COUNTER FIFTH GEAR (H55F)

- (a) Install the No. 3 hub sleeve and shifting keys to the counter 5th gear.
- (b) Install the shifting key springs under the shifting keys so that the spring ends are not in line, as shown in the figure.

21. INSTALL NEEDLE ROLLER BEARING (H55F)

- (a) Apply MP grease to the needle roller bearing.
- (b) Install the needle roller bearing into the counter 5th gear.

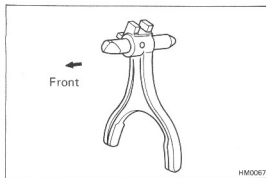

22. ASSEMBLE FIFTH SHIFT FORK (H55F)

- (a) Install the 5th shift fork to the shaft.
- (b) Align the pin holes with the 5th shift fork and shaft.
- (c) Using a pin punch, drive in the slotted spring pin.

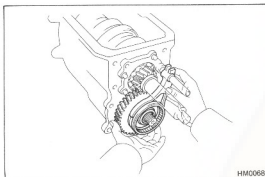

23. INSTALL COUNTER FIFTH GEAR ASSEMBLY WITH FIFTH SHIFT FORK (H55F)

- (a) Install the 5th shift fork and fork shaft onto hub sleeve No. 3.
- (b) Install the counter 5th gear assembly with the 5th shift fork.

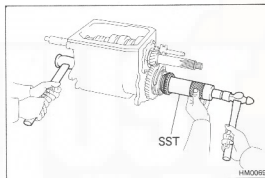

24. INSTALL SYNCHRONIZER RING AND GEAR SPLINE PIECE NO.5 (H55F)

- (a) Align the synchronizer ring slots with the shifting keys, and place the synchronizer ring on the counter 5th gear rear end.
- (b) Using SST, drive gear spline piece No. 5 into the counter gear to where the lock nut can be installed.

SST 09316-60010

NOTE: When driving in gear spline piece No. 5, support the counter gear in front with a 3–5 lb hammer or equivalent.

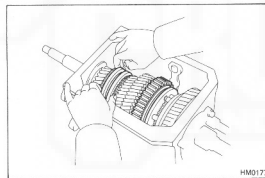

25. INSTALL LOCK NUT TO COUNTER GEAR REAR END (H55F)

- (a) Engage the gear double meshing.

- (b) Using SST, install a new lock nut. Torque the nut.

SST 09326-20011

Torque: 1,300 kg-cm (94 ft-lb, 127 N-m)

- (c) Disengage the gear double meshing.

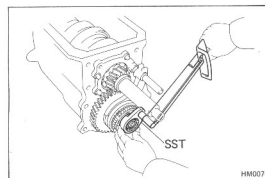

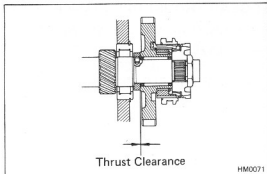

- (d) Using a feeler gauge, measure the counter 5th gear thrust clearance.

Standard clearance: 0.150 – 0.250 mm
(0.0059 – 0.0098 in.)
Maximum clearance: 0.30 mm (0.0118 in.)

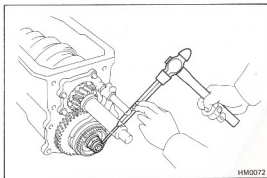

- (e) Using a punch, stake the lock nut.

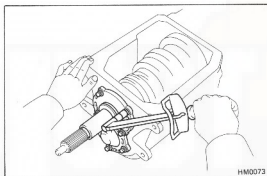

26. INSTALL FRONT BEARING RETAINER WITH A GASKET

- (a) Install the front bearing retainer with a gasket.
(b) Apply liquid sealer to the bolts.
(c) Install and torque the bolts.

Torque: 170 kg-cm (12 ft-lb, 17 N-m)

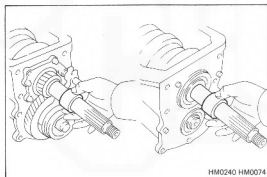

27. INSTALL SPACER

Install the spacer on the output shaft.

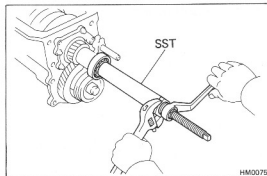

28. INSTALL OUTPUT SHAFT REAR BEARING (H55F)

Using SST, install the rear bearing.
SST 09309-36032

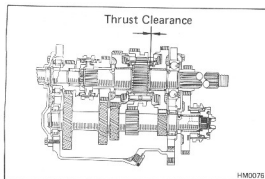

29. MEASURE FIRST GEAR THRUST CLEARANCE

Using a feeler gauge, measure the thrust clearance.

Standard clearance: 0.175 – 0.325 mm
(0.0069 – 0.0128 in.)

Maximum clearance: 0.35 mm (0.0138 in.)

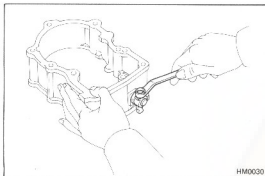

30. INSTALL FIFTH SHIFT ARM AND SHAFT (H55F)

(a) Install the 5th shift arm shaft through the transfer adapter and install the 5th shift arm.

(b) Install the bolt with a lock washer, and torque the bolt.

Torque: 380 kg-cm (27 ft-lb, 37 N-m)

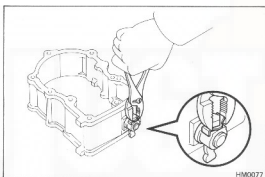

(c) Stake the lock washer.

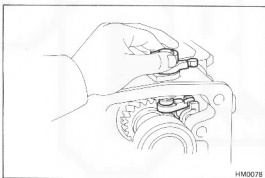

31. INSTALL TRANSFER ADAPTER WITH A GASKET (H55F)

(a) Place a new gasket in position.

(b) Align the end of the 5th shift lever and 5th shift fork, and install the transfer adapter.

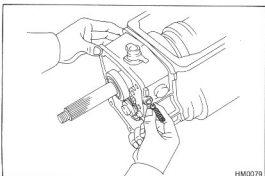

(c) Install the locking ball and spring.

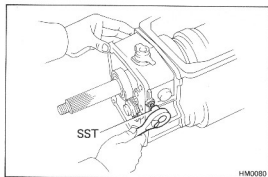

- (d) Apply liquid sealer to the plug.
 - (e) Using SST, install and torque the screw plug.
- SST 09313-30021
Torque: 250 kg-cm (18 ft-lb, 25 N-m)

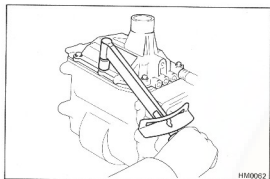

32. INSTALL CASE COVER WITH A GASKET

- (a) Install the case cover with a gasket.
 - (b) Install and torque the bolts.
- Torque: 400 kg-cm (29 ft-lb, 39 N-m)

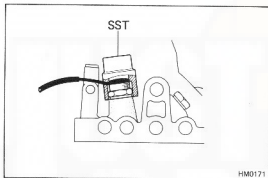

33. INSTALL BACK-UP LIGHT SWITCH AND SHIFT POINT SENSOR SWITCH TO CASE COVER

- Using SST, install the back-up light and shift point sensor switches.
- SST 09817-16011

34. INSTALL TRANSFER (See pages TF 15 to 22)

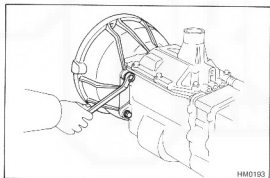

35. INSTALL CLUTCH HOUSING (Ex. FJ model)

- Torque the bolts.
- Torque: 730 kg-cm (53 ft-lb, 72 N-m)

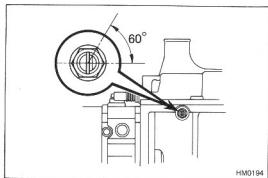

36. ADJUST REVERSE SHIFT ARM PIVOT POSITION

- (a) Position the adjustment mark on the shift arm pivot end toward the front.
 - (b) Temporarily install the shift lever, and if the shift lever is catching on something in selecting direction, adjust by moving the position of the alignment mark with 60°.
 - (c) Torque the nut.
- Torque: 250 kg-cm (18 ft-lb, 25 N-m)

H50 TRANSMISSION COMPONENTS

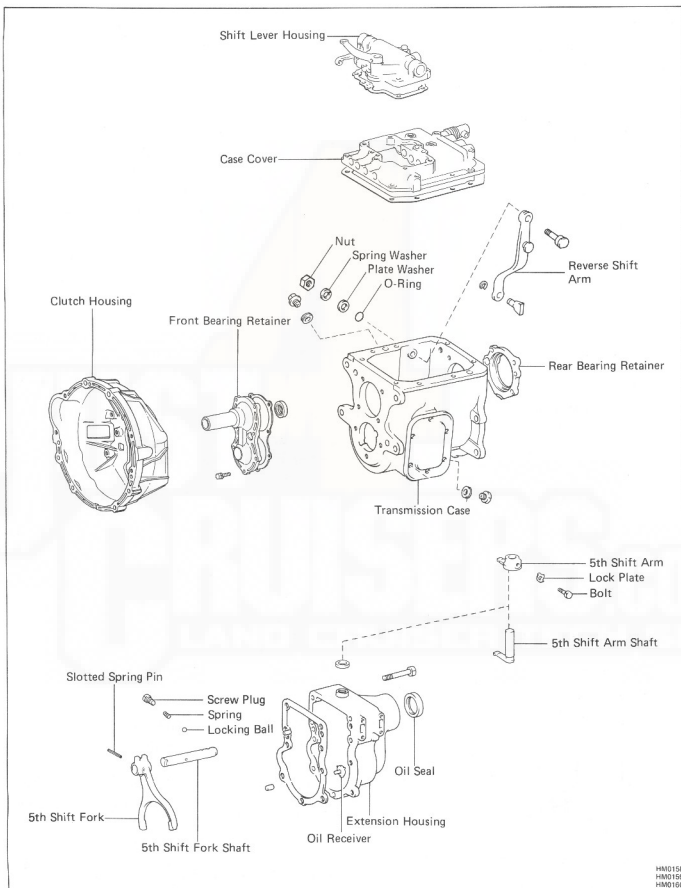

COMPONENTS (Cont'd)

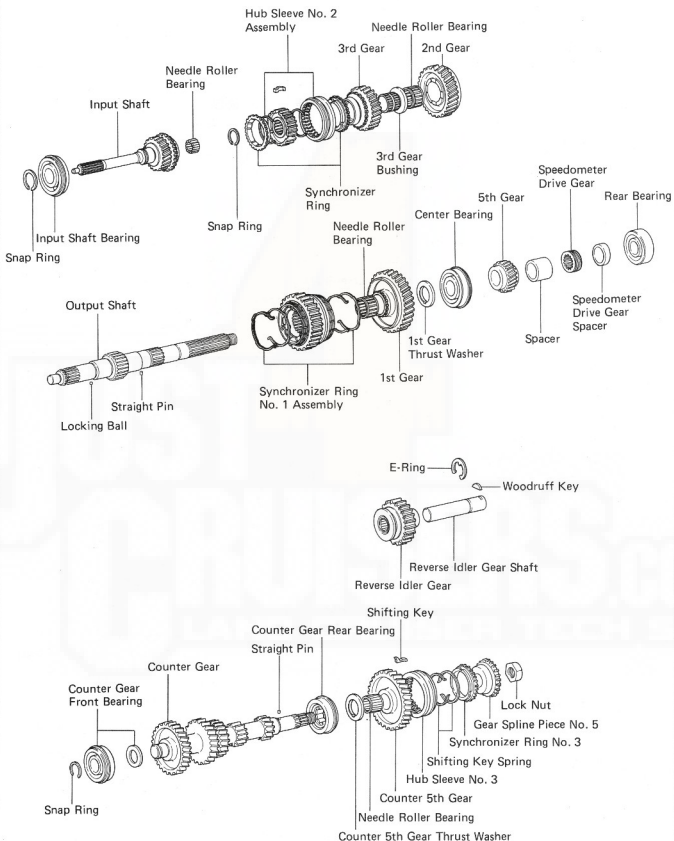

COMPONENTS (Cont'd)

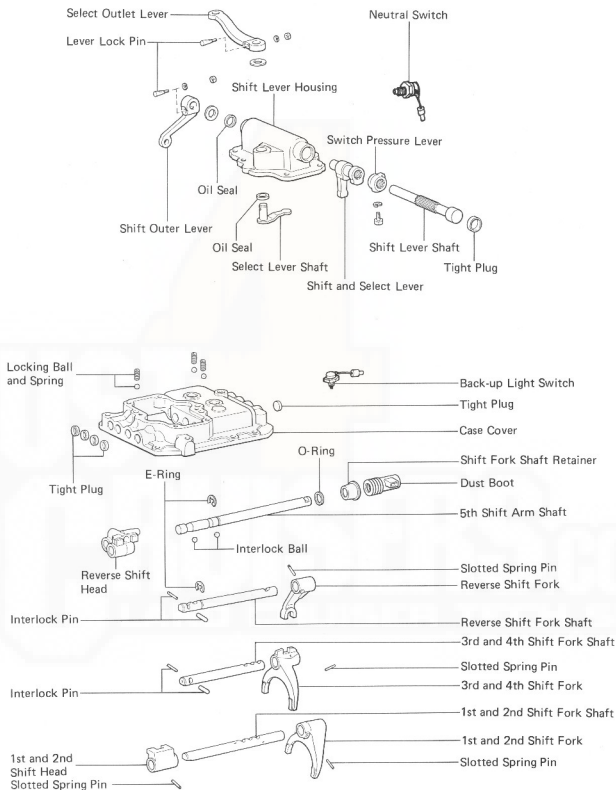

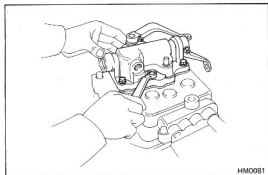

DISASSEMBLY OF TRANSMISSION

(See pages MT-40, 41)

1. REMOVE CLUTCH HOUSING
2. REMOVE NEUTRAL SWITCH, BACK-UP LIGHT SWITCH, SHIFT LEVER SHAFT SUPPORT, ENGINE REAR MOUNTING AND SPEEDOMETER DRIVEN GEAR
3. REMOVE SHIFT LEVER HOUSING
4. REMOVE LOCKING BALLS AND SPRINGS
Using a magnetic finger, remove the springs and balls.
5. REMOVE CASE COVER

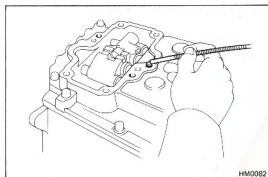

6. REMOVE FIFTH LOCKING BALL AND SPRING
 - (a) Using SST, remove the screw plug.
 - SST 09313-30021
 - (b) Using a magnetic finger, remove the locking ball and spring.

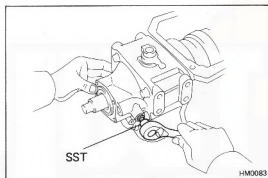

7. REMOVE EXTENSION HOUSING
 - (a) Remove the bolts.
 - (b) Using a brass bar and hammer, carefully tap off the extension housing.
 - (c) Pull up the 5th shift arm and pull the extension housing from the transmission case.

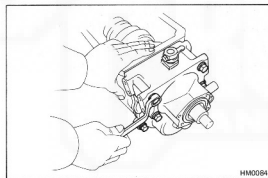

8. MEASURE EACH GEAR THRUST CLEARANCE
Using a feeler gauge, measure the thrust clearance of each gear.

NOTE: For later reference, write down the thrust clearance.

Standard clearance:

1st and 2nd gears	0.175 – 0.325 mm (0.0069 – 0.0128 in.)
3rd gear	0.125 – 0.275 mm (0.0049 – 0.0108 in.)
Counter 5th gear	0.10 – 0.30 mm (0.0039 – 0.0118 in.)

Maximum clearance:

1st and 2nd gears	0.35 mm (0.0138 in.)
3rd and counter 5th gears	0.30 mm (0.0118 in.)

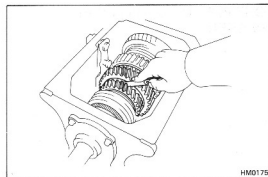

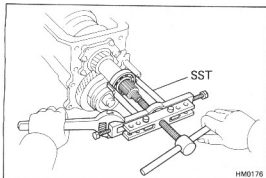

9. REMOVE OUTPUT SHAFT REAR BEARING

Using SST, remove the rear bearing.
SST 09950-20015

10. REMOVE SPACERS AND SPEEDOMETER DRIVE GEAR

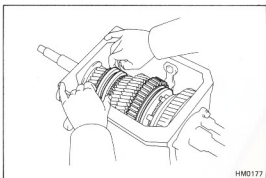

11. REMOVE COUNTER GEAR REAR LOCK NUT

- (a) Engage the gear double meshing.
- (b) Unstake the lock nut.

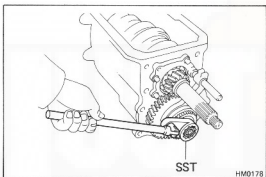

- (c) Using SST, remove the lock nut.
SST 09326-20011
- (d) Disengage the gear double meshing.

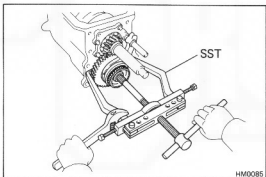

12. REMOVE GEAR SPLINE PIECE NO. 5, COUNTER FIFTH GEAR ASSEMBLY AND FIFTH SHIFT FORK

Using SST, pull the counter 5th gear out of the counter gear rear end with gear spline piece No. 5 and the 5th shift fork.

SST 09950-20015

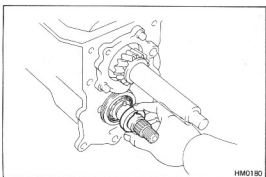

13. REMOVE STRAIGHT PIN AND COUNTER FIFTH GEAR THRUST WASHER

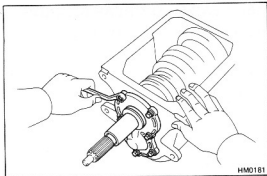
**14. REMOVE FRONT BEARING RETAINER**

NOTE: Be careful not to damage the oil seal.

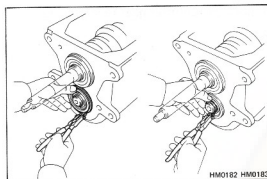
**15. REMOVE COUNTER GEAR FRONT BEARING**

(a) Using snap ring pliers, remove the snap rings.

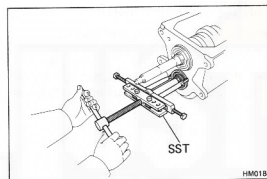

(b) Using SST, remove the counter gear front bearing.
SST 09950-20015

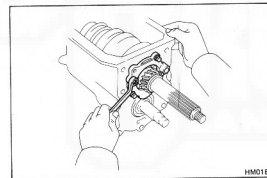
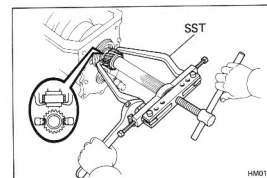
**16. REMOVE REAR BEARING RETAINER****17. REMOVE FIFTH GEAR FROM OUTPUT SHAFT**

Using SST, remove the 5th gear from the output shaft.
SST 09950-20015

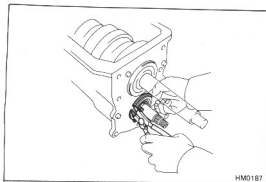

18. REMOVE COUNTER GEAR SHAFT REAR BEARING

- (a) Using snap ring pliers, remove the snap ring.

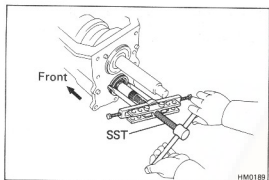

- (b) Using SST, remove the counter gear rear bearing.
SST 09950-20015

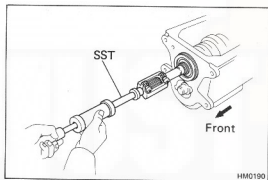

19. REMOVE INPUT SHAFT AND BEARING

- (a) Using SST, remove the input shaft and bearing.
SST 09910-00015

NOTE: Insure that the input shaft and counter gear do not strike against each other. Be careful not to lose the 17 needle roller bearings.

- (b) Remove the synchronizer ring.

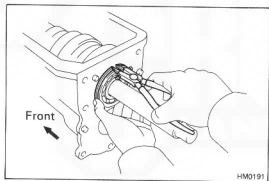

20. REMOVE OUTPUT SHAFT CENTER BEARING

- (a) Using snap ring pliers, remove the snap ring.

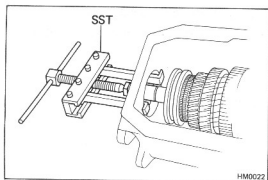

- (b) Using SST, support the output shaft front end.
SST 09213-27010

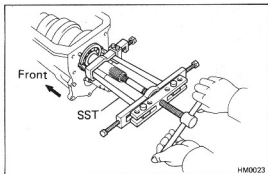

- (c) Using SST, remove the center bearing.
SST 09950-20015

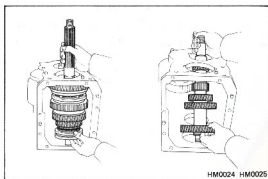

21. REMOVE OUTPUT SHAFT AND COUNTER GEAR

- (a) Stand the transmission case on its front end.
(b) Remove the output shaft.
(c) Remove the counter gear.

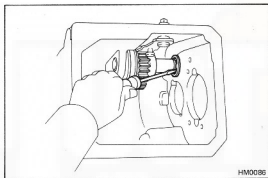

22. REMOVE REVERSE IDLER GEAR AND SHAFT

- (a) Remove the E-ring from the shaft.

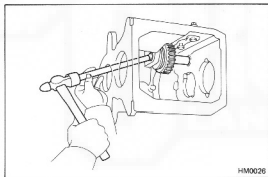

- (b) Tap out the reverse idler gear shaft toward the rear.
(c) Remove the gear and the woodruff key.

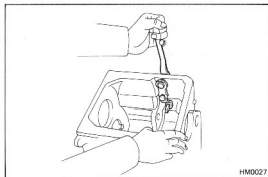

23. REMOVE REVERSE SHIFT ARM FROM TRANSMISSION CASE

- Remove the nut, washers, O-ring, pivot arm and reverse shift arm.

24. REMOVE FIRST GEAR THRUST WASHER, STRAIGHT PIN, FIRST GEAR AND NEEDLE ROLLER BEARING FROM OUTPUT SHAFT
25. REMOVE SYNCHRONIZER RING NO. 1 ASSEMBLY FROM OUTPUT SHAFT

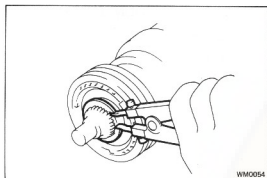

26. REMOVE HUB SLEEVE NO. 2 ASSEMBLY, SYNCHRONIZER RING, THIRD GEAR, THIRD GEAR BUSHING, NEEDLE ROLLER BEARING AND SECOND GEAR

(a) Using snap ring pliers, remove the snap ring.

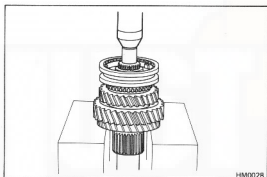

(b) Using a press, remove the hub sleeve No. 2 assembly, synchronizer ring, 3rd gear, 3rd gear bushing, needle roller bearing and 2nd gear.

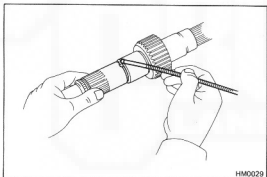

27. REMOVE LOCKING BALL

Using a magnetic finger, remove the locking ball.

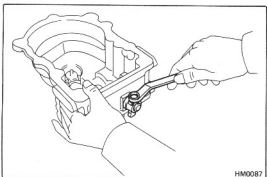

28. REMOVE FIFTH SHIFT ARM AND SHAFT

(a) Remove the bolt and lock washer.

(b) Remove the 5th shift arm and shaft.

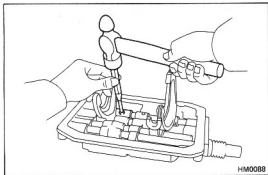

DISASSEMBLY OF CASE COVER ASSEMBLY

(See page MT-42)

1. REMOVE FIRST AND SECOND SHIFT FORK SHAFT, SHIFT HEAD AND SHIFT FORK

CAUTION: When removing the shaft, place each shift fork into neutral position and release the interlock pin.

- (a) Drive out the slotted spring pins from the shift head and shift fork.

NOTE: When driving out the slotted spring pins, tilt the fork so the pins do not make contact with the case cover.

- (b) Drive out the shift fork shaft and tight plug.
 (c) Remove the shift head and shift fork.

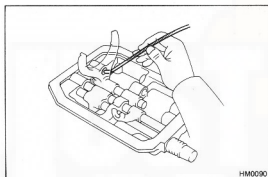
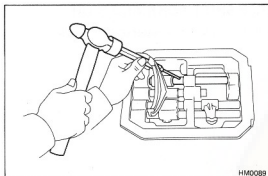

- (d) Remove the interlock pin from the case cover.

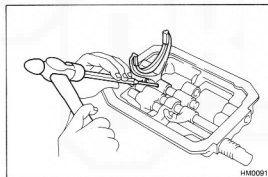

2. REMOVE THIRD AND FOURTH SHIFT FORK AND SHAFT

- (a) Drive out the slotted spring pin.

- (b) Drive out the shift fork shaft, small interlock pin and tight plug.

- (c) Remove the shift fork.

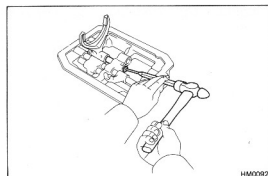

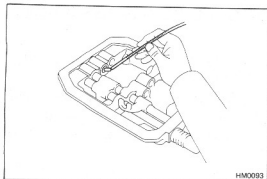

(d) Remove the interlock pin from the case cover.

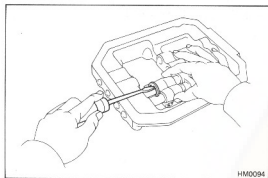

3. REMOVE REVERSE SHIFT FORK AND SHAFT

(a) Remove the E-ring from the reverse shift fork shaft.

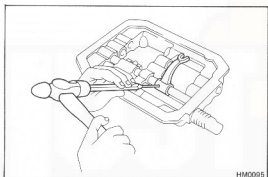

(b) Drive out the slotted spring pin from the shift fork.

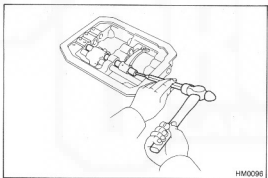

(c) Drive out the shift fork shaft, small interlock pin and tight plug.

(d) Remove the shift fork.

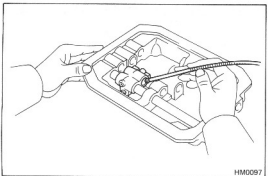

(e) Remove the interlock balls from the case cover and reverse shift head.

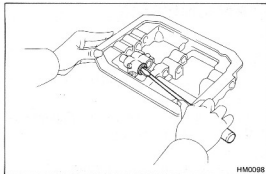
**4. REMOVE FIFTH SHIFT ARM SHAFT**

- (a) Remove the dust boot.
- (b) Remove the E-ring.

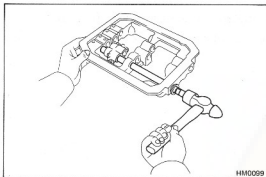

- (c) Drive out the 5th shift arm shaft and tight plug.
- (d) Remove the reverse shift head.
- (e) Remove the shift fork shaft retainer and O-ring.

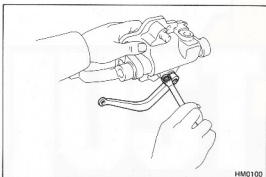
**5. REMOVE SELECT LEVER SHAFT**

- (a) Remove the lock pin on the select outer lever.
- (b) Remove the select outer lever, washer and select lever shaft.

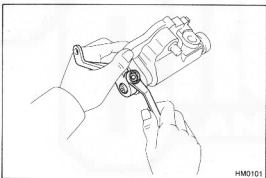
**6. REMOVE SHIFT LEVER SHAFT**

- (a) Remove the lock pin on the shift outer lever.
- (b) Remove the shift outer lever and washer.

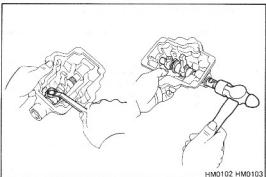

- (c) Remove the bolt.
- (d) Drive out the shift lever shaft and tight plug.
- (e) Remove the switch pressure lever and shift and select lever.

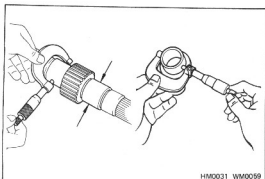

HM0031 WM0059

INSPECTION OF TRANSMISSION COMPONENTS

1. INSPECT OUTPUT SHAFT AND BUSHING

- Check the output shaft and bushing for wear or damage.
- Using a micrometer, measure the outer diameter of the output shaft journal and bushing.

Minimum diameter:

1st and 2nd gear journals 43.93 mm (1.7295 in.)

Bushing 47.91 mm (1.8862 in.)

- Using a dial indicator, measure the shaft runout.

Maximum runout: 0.03 mm (0.0012 in.)

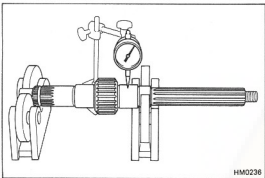

HM0238

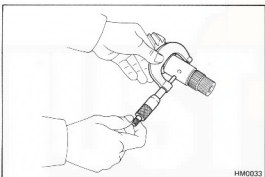

HM0033

2. INSPECT COUNTER GEAR AND BEARINGS

- Check the gear teeth for wear or damage.
- Check the bearings for wear or damage.
- Using a micrometer, measure the outer diameter of the counter gear journal.

Minimum diameter:

Counter 5th gear journal 31.93 mm (1.2571 in.)

Rear bearing journal 39.90 mm (1.5709 in.)

3. INSPECT OIL CLEARANCE OF FIRST, SECOND AND COUNTER FIFTH GEARS

Using a dial indicator, measure the oil clearance between the gear and shaft with the needle roller bearing installed.

Standard clearance:

1st and 2nd gears 0.020 – 0.073 mm
(0.0008 – 0.0029 in.)

Counter 5th gear 0.015 – 0.068 mm
(0.0006 – 0.0027 in.)

Maximum clearance:

1st and 2nd gears 0.08 mm (0.0031 in.)

Counter 5th gear 0.07 mm (0.0028 in.)

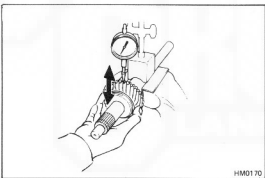

HM0170

4. INSPECT OIL CLEARANCE OF THIRD GEAR

Using a dial indicator, measure the oil clearance between the gear and bushing.

Standard clearance: 0.065 – 0.115 mm
(0.0026 – 0.0045 in.)

Maximum clearance: 0.12 mm (0.0047 in.)

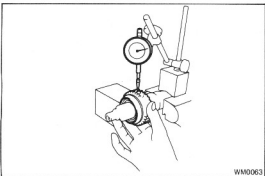

WM0063

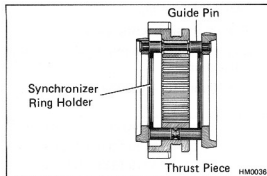

5. INSPECT SYNCHRONIZER RINGS OF FIRST AND SECOND GEARS

- Check the inner spline for wear or damage.
- Check the raised portion of the guide pins for wear or damage.
- Check the thrust pieces and gear moving parts for wear or damage.
- Check the guide pin rivet staked parts for play or damage.
- Check the synchronizer ring holders for deterioration or wear.
- With the synchronizer ring pressed into the gear, measure the distance as shown.

Minimum distance:

1st gear	32.5 mm (1.280 in.)
2nd gear	38.0 mm (1.496 in.)

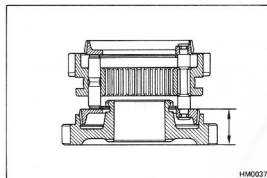

6. INSPECT SYNCHRONIZER RINGS OF THIRD GEAR, INPUT SHAFT AND GEAR SPLINE PIECE NO. 5

- Check the synchronizer rings for wear or damage.
- Turn the ring and push it in to check the braking action.
- Measure the clearance between the synchronizer ring back and the gear spline end.

Minimum clearance: 0.8 mm (0.031 in.)

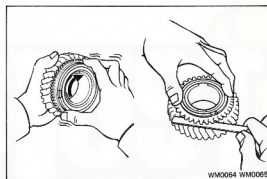

7. INSPECT SHIFT FORKS AND HUB SLEEVES

- Check the contact surface for wear or damage.
- Measure the clearance between the hub sleeve and the shift fork.

Maximum clearance: 0.8 mm (0.031 in.)

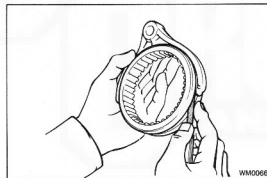

8. INSPECT INPUT SHAFT AND BEARING

Check for wear or damage.

9. IF NECESSARY, REPLACE INPUT SHAFT BEARING

- Using snap ring pliers, remove the snap ring.
- Using a press, remove the bearing.

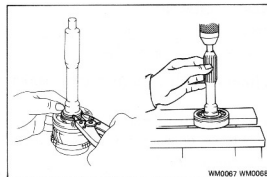

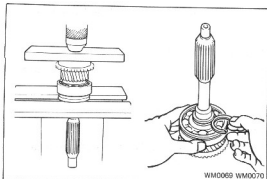

(c) Using a press, install the bearing.

CAUTION: Do not press in the bearing outer race.

(d) Select a snap ring that will allow minimum axial play and install it on the shaft.

Standard play: 0 – 0.10 mm (0 – 0.0039 in.)

Part No.	Thickness mm (in.)
90520 – 36016	3.20 – 3.31 (0.1260 – 0.1303)
90520 – 36015	3.31 – 3.42 (0.1303 – 0.1346)

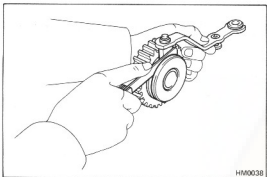

10. INSPECT REVERSE SHIFT ARM AND REVERSE IDLER GEAR

(a) Check for wear or damage.

(b) Measure the clearance between the shift arm shoe and idler gear groove.

Maximum clearance: 0.7 mm (0.028 in.)

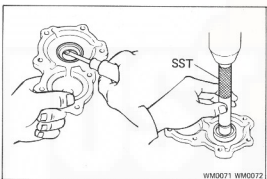

11. INSPECT FRONT BEARING RETAINER

(a) Check for damage.

(b) Check the oil seal for wear or damage.

12. IF NECESSARY, REPLACE FRONT BEARING RETAINER OIL SEAL

(a) Using a screwdriver, pry out the oil seal.

(b) Using SST, press in a new oil seal.

SST 09950-20015

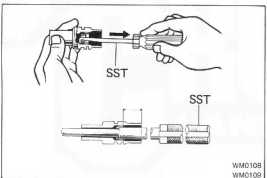

13. IF NECESSARY, REPLACE SPEEDOMETER DRIVEN GEAR OIL SEAL

(a) Using SST, pry out the oil seal.

SST 09921-00010

(b) Using SST, drive in a new oil seal.

SST 09201-60011

Drive in depth: 23.3 mm (0.917 in.)

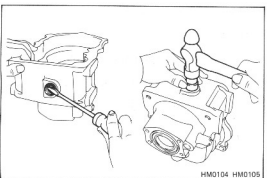

14. INSPECT EXTENSION HOUSING

(a) Check for damage.

(b) Check the oil seals for wear or damage.

15. IF NECESSARY, REPLACE FIFTH SHIFT ARM SHAFT OIL SEAL

(a) Using a screwdriver, pry out the oil seal.

(b) Using a socket wrench, drive in a new oil seal.

Drive in depth: 1.0 mm (0.039 in.)

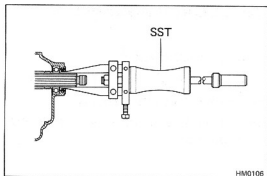
**16. IF NECESSARY, REPLACE REAR OIL SEAL**

(a) Using SST, remove the oil seal.

SST 09308-00010

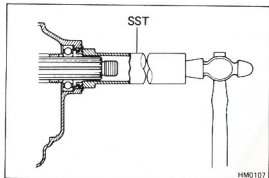

(b) Using SST, drive in a new oil seal.

SST 09316-60010

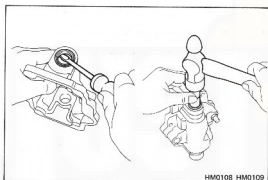
**17. IF NECESSARY, REPLACE SHIFT LEVER SHAFT OIL SEAL**

(a) Using a screwdriver, pry out the oil seal.

(b) Using a socket wrench, drive in a new oil seal.

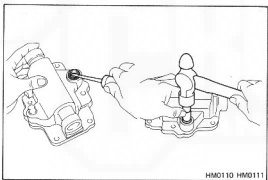
**18. IF NECESSARY, REPLACE SELECT LEVER SHAFT OIL SEAL**

(a) Using a screwdriver, pry out the oil seal.

(b) Using a socket wrench, drive in a new oil seal.

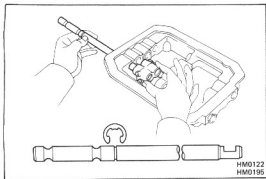

ASSEMBLY OF CASE COVER ASSEMBLY

(See page MT-42)

1. INSTALL FIFTH SHIFT FORK SHAFT

- (a) Install the O-ring and shift fork shaft retainer.
- (b) Put the reverse shift head into the case cover.
- (c) Install the 5th shift fork shaft into the reverse shift head through the case cover.
- (d) Install the E-ring.
- (e) Install the dust boot.

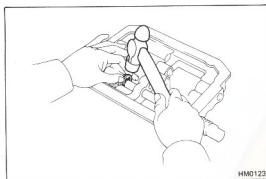

2. INSTALL REVERSE SHIFT FORK AND SHAFT

- (a) Apply MP grease to the interlock balls.
- (b) Install the interlock ball into the case cover.

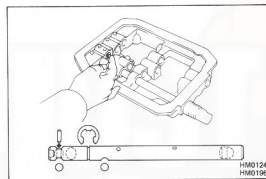

- (c) Install the interlock ball into the reverse shift head.

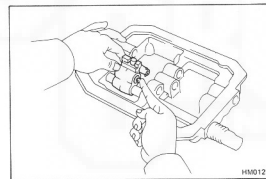

- (d) Apply MP grease to the interlock pin.
- (e) Install the small interlock pin into the fork shaft hole.

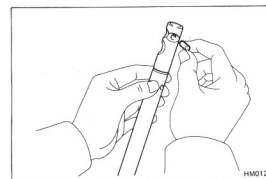

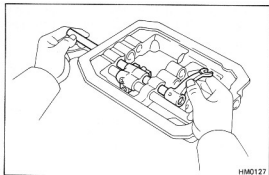

HM0127

- (f) Put the reverse shift fork into the case cover and install the fork shaft into the shift fork and reverse shift head through the case cover.
- (g) Install the E-ring.

3. INSTALL THIRD AND FOURTH SHIFT FORK AND SHAFT

- (a) Apply MP grease to the interlock pin.
- (b) Install the interlock pin into the case cover.

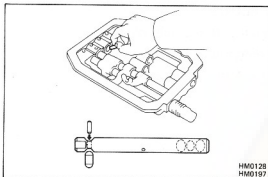
HM0128
HM0197

- (c) Apply MP grease to the small interlock pin.
- (d) Install the small interlock pin into the fork shaft hole.

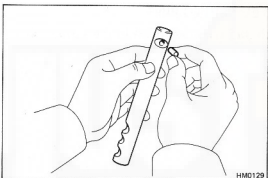

HM0129

- (e) Put the 3rd and 4th shift fork into the case cover and install the fork shaft into the case cover through the shift fork.

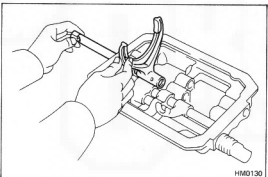

HM0130

4. INSTALL FIRST AND SECOND SHIFT FORK SHAFT, SHIFT HEAD AND SHIFT FORK

- (a) Apply MP grease to the interlock pin.
- (b) Install the interlock pin into the case cover.

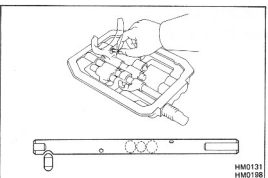
HM0131
HM0198

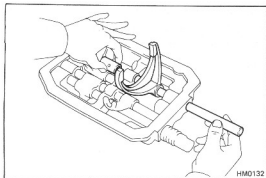

- (c) Put the shift head and shift fork into the case cover and install the fork shaft into the case cover through the shift head and shift fork.

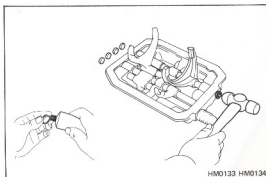

5. INSTALL TIGHT PLUGS

- (a) Apply liquid sealer to the tight plugs.
 (b) Drive in the tight plugs.

Drive in depth: 1 – 2 mm (0.04 – 0.08 in.)

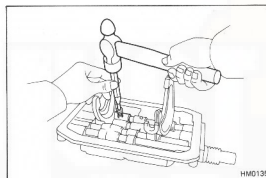

6. INSTALL SLOTTED SPRING PINS

Using a pin punch and hammer, drive in the slotted spring pins.

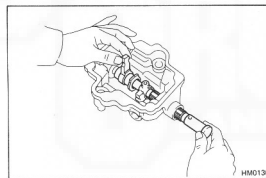

7. INSTALL SHIFT LEVER SHAFT

- (a) Put the shift and select lever and pressure switch lever into the shift lever housing.
 (b) Install the shift lever shaft into the shift and select lever and pressure switch lever through the shift lever housing.

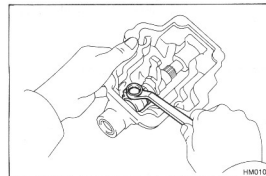

- (c) Install and torque the bolt.

Torque: 160 kg-cm (12 ft-lb, 16 N-m)

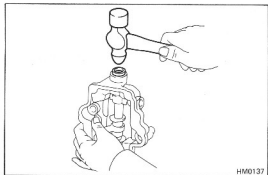

(d) Apply liquid sealer to the tight plug and drive in it.

Drive in depth: 1.0 – 2.8 mm from shift lever shaft
(0.039 – 0.110 in.)

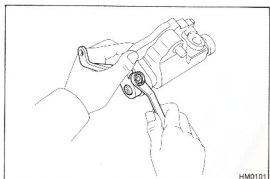

(e) Install the washer and shift outer lever.

(f) Install the lock pin and nut.

Torque: 200 kg-cm (14 ft-lb, 20 N-m)

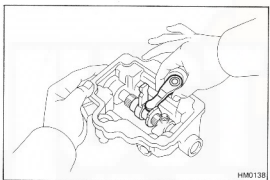

8. INSTALL SELECT LEVER SHAFT

(a) Install the select lever shaft, washer and select outer lever.

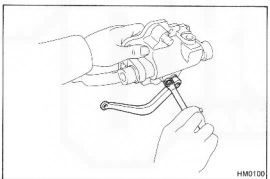

(b) Install the lock pin and nut.

Torque: 80 kg-cm (69 in.-lb, 7.8 N-m)

ASSEMBLY OF TRANSMISSION

(See pages MT-40, 41)

1. INSTALL SECOND GEAR AND NEEDLE ROLLER BEARING

- (a) Apply gear oil to the output shaft.
- (b) Install the needle roller bearing and 2nd gear.

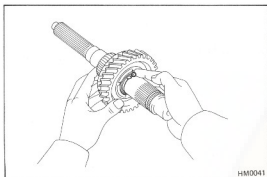
**2. INSTALL LOCKING BALL, BUSHING AND THIRD GEAR**

- (a) Install the locking ball in the shaft.

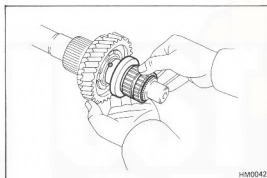

- (b) Install the bushing on the output shaft and align the bushing notch and locking ball.
- (c) Apply gear oil to the bushing.
- (d) Install the 3rd gear on the bushing.

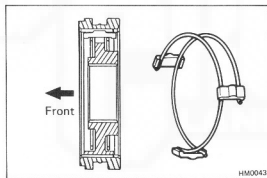
**3. INSERT CLUTCH HUB NO. 2 INTO HUB SLEEVE**

- (a) Install the clutch hub and shifting keys to the hub sleeve.
- (b) Install the shifting key springs under the shifting keys.

CAUTION: Install the key springs positioned so that their ends are not in line.

4. INSTALL HUB SLEEVE NO.2 ASSEMBLY

Using a press, install the hub sleeve No. 2 assembly.

CAUTION: Hold the 3rd gear to prevent the bushing from falling. Be sure that the shifting keys align with the synchronizer ring slots.

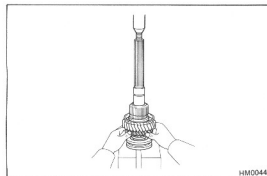

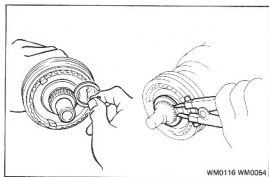

5. INSTALL SNAP RING

Select a snap ring that will allow minimum axial play and install it on the shaft.

Mark	Thickness	mm (in.)
0	2.40 – 2.45	(0.0945 – 0.0965)
1	2.45 – 2.50	(0.0965 – 0.0984)
2	2.50 – 2.55	(0.0984 – 0.1004)
3	2.55 – 2.60	(0.1004 – 0.1024)
4	2.60 – 2.65	(0.1024 – 0.1043)
5	2.65 – 2.70	(0.1043 – 0.1063)

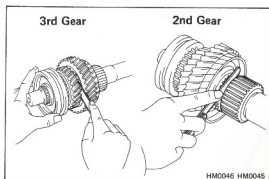

6. MEASURE SECOND AND THIRD GEARS THRUST CLEARANCE

Using a feeler gauge, measure the 2nd and 3rd gear thrust clearances.

Standard clearance:

2nd gear 0.175 – 0.325 mm (0.0069 – 0.0128 in.)

3rd gear 0.125 – 0.275 mm (0.0049 – 0.0108 in.)

Maximum clearance:

2nd gear 0.35 mm (0.0138 in.)

3rd gear 0.30 mm (0.0118 in.)

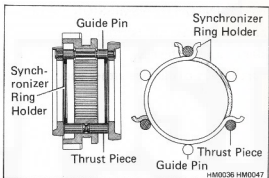

7. ASSEMBLE SYNCHRONIZER RING HOLDER

Hook the synchronizer ring holder ends to the thrust piece.

NOTE:

- Align the synchronizer ring holder ends so they are not both facing in the same direction.
- So sure that the synchronizer ring holders are parallel and not intersecting.

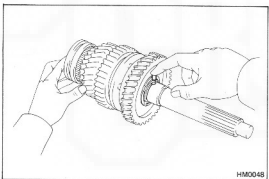

8. INSTALL SYNCHRONIZER RING NO. 1 AND FIRST GEAR

- Install synchronizer ring No. 1.
- Apply gear oil to the needle roller bearing.
- Install the needle roller bearing and 1st gear.
- Apply MP grease to the straight pin and 1st gear thrust washer.
- Install the 1st gear thrust washer on the output shaft with the straight pin aligned with the 1st gear thrust washer.

9. INSTALL REVERSE SHIFT ARM

- Install the reverse shift arm so its pivot is positioned as shown.
- Install the O-ring, plate washer, spring washer and nut.

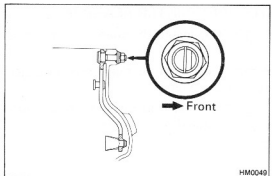

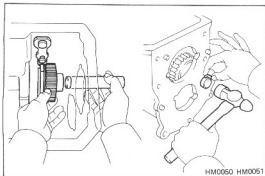

10. INSTALL REVERSE IDLER GEAR AND SHAFT

- (a) Align the reverse idler gear groove with the reverse shift arm shoe.
- (b) Install the reverse idler gear shaft with the woodruff key through the gear.

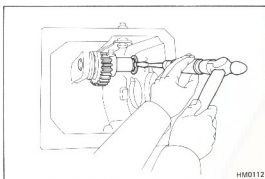

- (c) Install the E-ring onto the shaft.

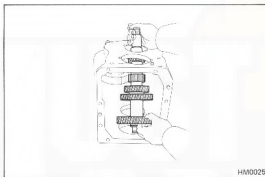

11. PUT COUNTER GEAR INTO TRANSMISSION CASE

- (a) Stand the transmission case on its front end.
- (b) Put the counter gear into the case.

CAUTION: Be careful not to damage either end.

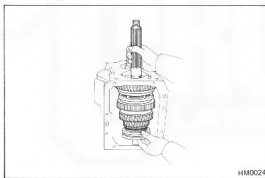

12. PUT OUTPUT SHAFT ASSEMBLY INTO TRANSMISSION CASE

CAUTION: Be careful not to damage the front end of the shaft.

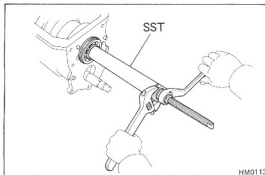

13. INSTALL OUTPUT SHAFT CENTER BEARING

- (a) Using snap ring pliers, install the snap ring onto the bearing.
- (b) Confirm that the groove of the 1st gear thrust washer and the straight pin are aligned.
- (c) Using SST, install the bearing until it comes into contact with the 1st gear thrust washer.

SST 09309-36040

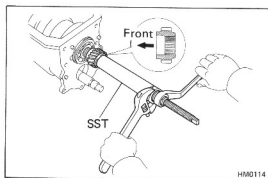
**14. INSTALL FIFTH GEAR TO OUTPUT SHAFT**

- (a) Apply MP grease to the inside surface of the 5th gear.
- (b) Using SST, install the 5th gear to the output shaft.
SST 09309-36040

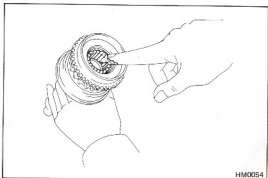
**15. INSTALL INPUT SHAFT**

- (a) Using snap ring pliers, install the snap ring onto the bearing.
- (b) Install the 17 needle roller bearings into the input shaft.
- (c) Apply MP grease to the needle roller bearings.

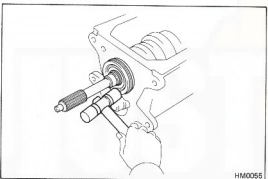

- (d) Align the synchronizer ring slots with the shifting keys.

- (e) Using a plastic hammer, drive in the input shaft.

NOTE: Be sure that the counter gear is low enough so as not to interfere with the input shaft.

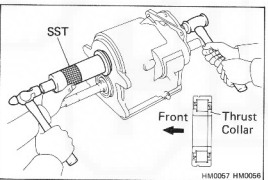
**16. INSTALL COUNTER GEAR FRONT BEARING**

- (a) Turn the transmission over and align the counter gear center.
- (b) Install the thrust collar for the front bearing onto the counter gear.

- (c) Using SST, drive in the bearing.

SST 09316-60010

NOTE: When driving in the bearing, support the counter gear in rear with a 3–5 lb hammer or equivalent.

- (d) Install the snap ring onto the bearing outer race.

- (e) Select a snap ring that will allow minimum axial play and install it on the counter gear front end.

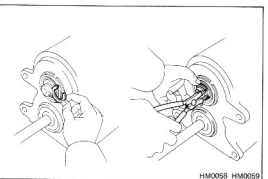

Mark	Thickness	mm(in.)
0	2.05 – 2.10	(0.0807 – 0.0827)
2	2.15 – 2.20	(0.0846 – 0.0866)
4	2.25 – 2.30	(0.0886 – 0.0906)

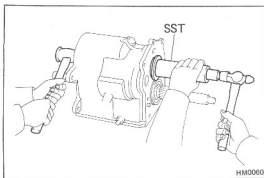
**17. INSTALL COUNTER GEAR REAR BEARING**

- (a) Install the snap ring to the counter gear rear bearing.
- (b) Using SST, drive the rear bearing into the transmission case.

SST 09316-60010

NOTE: When driving in the bearing, support the counter gear in front with 3–5 lb hammer or equivalent.

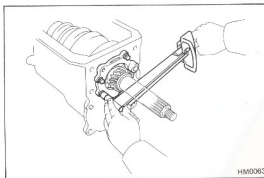
**18. INSTALL REAR BEARING RETAINER**

Install the rear bearing retainer to the transmission case.

Torque the bolts.

Torque: 185 kg-cm (13 ft-lb, 18 N-m)

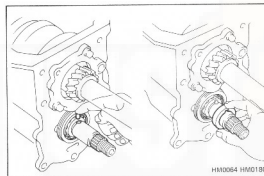
**19. INSTALL STRAIGHT PIN AND COUNTER FIFTH GEAR THRUST WASHER**

- (a) Install the straight pin onto the counter shaft.
- (b) Align the thrust washer slot with the straight pin, and install the thrust washer.

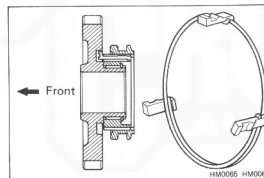
**20. ASSEMBLE COUNTER FIFTH GEAR**

- (a) Install the No. 3 hub sleeve and shifting keys to the counter 5th gear.
- (b) Install the shifting key springs under the shifting keys so that the spring ends are not in line, as shown in the figure.

21. INSTALL NEEDLE ROLLER BEARING

- (a) Apply MP grease to the needle roller bearing.
- (b) Install the needle roller bearing into the counter 5th gear.

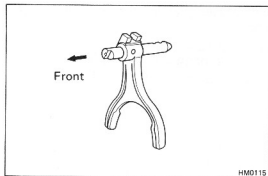
**22. ASSEMBLE FIFTH SHIFT FORK**

- Install the 5th shift fork to the shaft.
- Align the pin holes with the 5th shift fork and shaft.
- Using a pin punch, drive in the slotted spring pin.

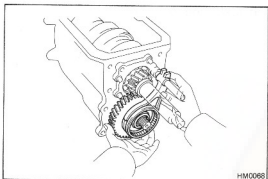
**23. INSTALL COUNTER FIFTH GEAR ASSEMBLY WITH FIFTH SHIFT FORK**

- Install the 5th shift fork and fork shaft onto hub sleeve No. 3.
- Install the counter 5th gear assembly with the 5th shift fork.

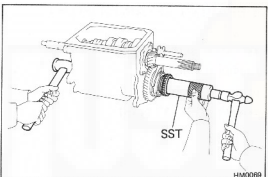
**24. INSTALL SYNCHRONIZER RING AND GEAR SPLINE PIECE NO. 5**

- Align the synchronizer ring slots with the shifting keys, and place the synchronizer ring on the counter 5th gear rear end.
- Using SST, drive gear spline piece No. 5 into the counter gear to where the lock nut can be installed.

SST 09316-60010

NOTE: When driving in gear spline piece No. 5, support the counter gear in front with a 3-5 lb hammer or equivalent.

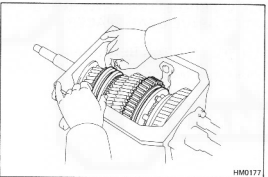
**25. INSTALL LOCK NUT TO COUNTER GEAR REAR END**

- Engage the gear double meshing.

- Using SST, install a new lock nut. Torque the nut.

SST 09326-20011

Torque: 1,300 kg-cm (94 ft-lb, 127 N·m)

- Disengage the gear double meshing.

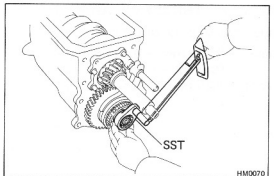

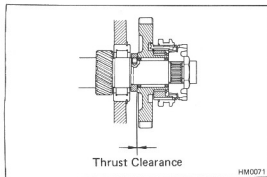

(d) Using a feeler gauge, measure the counter 5th gear thrust clearance.

Standard clearance: 0.10 – 0.30 mm
(0.0039 – 0.0118 in.)

Maximum clearance: 0.30 mm (0.0118 in.)

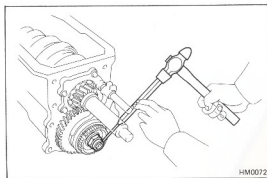

(e) Using a punch, stake the lock nut.

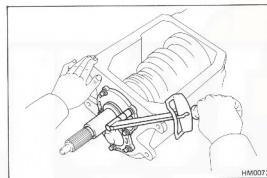

26. INSTALL FRONT BEARING RETAINER WITH A GASKET

(a) Install the front bearing retainer with a gasket.

(b) Apply liquid sealer to the bolts.

(c) Install and torque the bolts.

Torque: 170 kg-cm (12 ft-lb, 17 N-m)

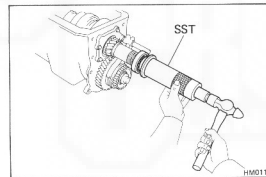

27. INSTALL SPACER, SPEEDOMETER DRIVE GEAR AND SPEEDOMETER DRIVE GEAR SPACER

28. INSTALL OUTPUT SHAFT REAR BEARING

Using SST, drive in the rear bearing.

SST 09316-60010

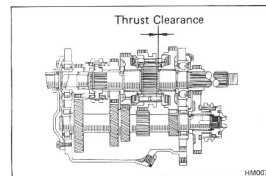

29. MEASURE FIRST GEAR THRUST CLEARANCE

Using a feeler gauge, measure the thrust clearance.

Standard clearance: 0.175 mm – 0.325 mm
(0.0069 – 0.0128 in.)

Maximum clearance: 0.35 mm (0.0138 in.)

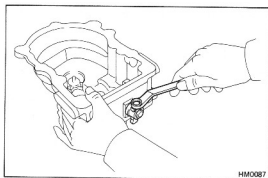
**30. INSTALL FIFTH SHIFT ARM AND SHAFT**

- (a) Install the 5th shift arm shaft through the extension housing and install the 5th shift arm.
- (b) Install the bolt with a lock washer, and torque the bolt.

Torque: 380 kg-cm (27 ft-lb, 37 N-m)

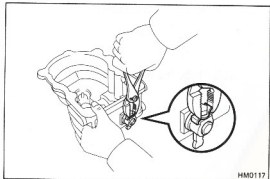

- (c) Stake the lock washer.

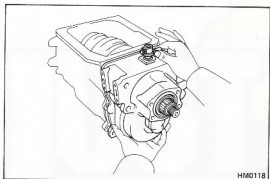
**31. INSTALL EXTENSION HOUSING WITH A GASKET**

- (a) Pull up the 5th shift arm and install the extension housing.
- (b) Align the 5th shift arm with the 5th shift fork.
- (c) Apply liquid sealer to the bolts.

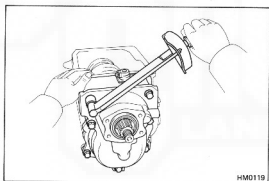

- (d) Install and torque the bolts.

Torque: 600 kg-cm (43 ft-lb, 59 N-m)

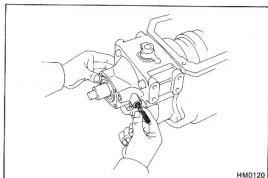

- (e) Install the locking ball and spring.
- (f) Apply liquid sealer to the screw plug.

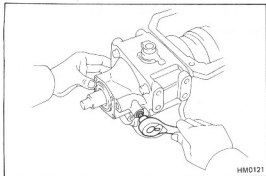

(g) Using SST, install and torque the screw plug.

SST 09313-30021

Torque: 250 kg-cm (18 ft-lb, 25 N-m)

32. INSTALL SPEEDOMETER DRIVEN GEAR

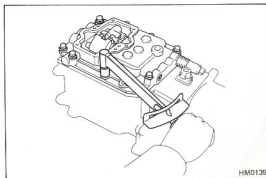

33. INSTALL CASE COVER WITH A GASKET

(a) Install the case cover with a gasket.

(b) Install and torque the bolts.

Torque: 530 kg-cm (38 ft-lb, 52 N-m)

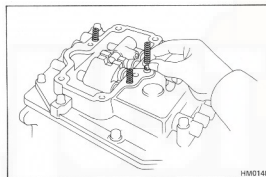

34. INSTALL SHIFT LEVER HOUSING WITH A GASKET

(a) Install the locking balls and springs.

(b) Install the shift lever housing with a gasket.

(c) Install and torque the bolts.

Torque: 195 kg-cm (14 ft-lb, 19 N-m)

35. INSTALL NEUTRAL SWITCH, BACK-UP LIGHT SWITCH, SPEEDOMETER DRIVEN GEAR, SHIFT LEVER SHAFT SUPPORT AND ENGINE REAR MOUNTING

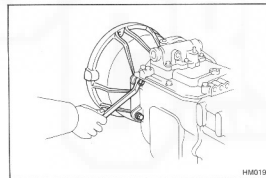

36. INSTALL CLUTCH HOUSING

Torque the bolts.

Torque: 730 kg-cm (53 ft-lb, 72 N-m)

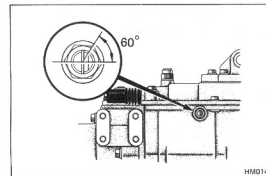

37. ADJUST REVERSE SHIFT ARM PIVOT POSITION

(a) Position the adjustment mark on the shift arm pivot end toward the front side.

(b) If the select lever is catching on something, adjust by moving the position of the alignment mark within 60°.

(c) Torque the nut.

Torque: 250 kg-cm (18 ft-lb, 25 N-m)

REMOTE CONTROL (DYNA FLOOR SHIFT SERIES) COMPONENTS

[For Regular-Cab Type]

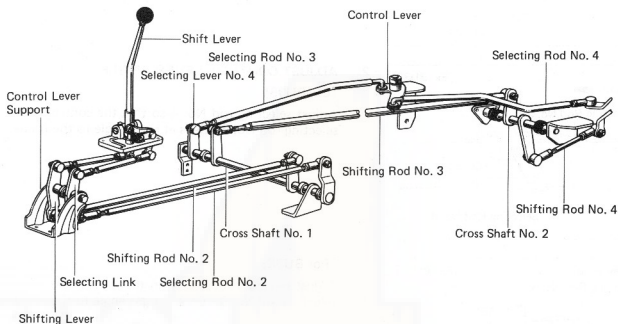

[For Wide-Cab Type]

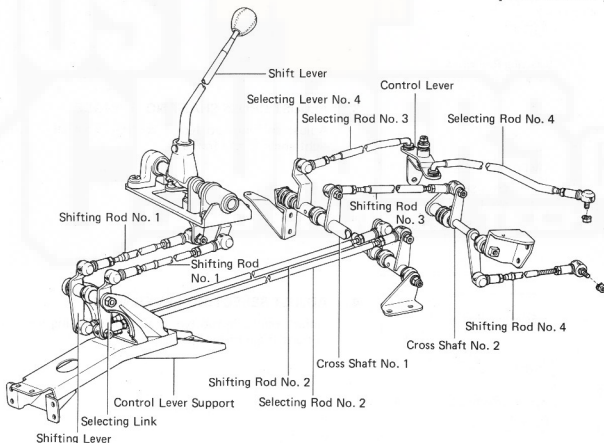

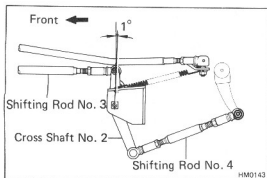

ADJUSTMENT OF SHIFT LEVER NEUTRAL POSITION

1. ADJUST CROSS SHAFT NO. 2 ANGLE

Adjust shifting rod No. 4 so that cross shaft No. 2 on the shifting rod No. 3 side is 1° from perpendicular position.

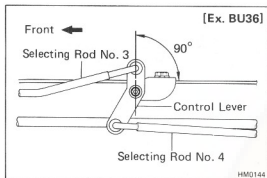

2. ADJUST CONTROL LEVER ANGLE

[Ex. BU36]

Adjust selecting rod No. 4 so that the control lever on the selecting rod No. 3 side is at right angle to the frame.

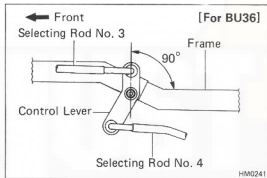

[For BU36]

Adjust selecting rod No. 4 so that the control lever on the selecting rod No. 3 side is at right angle to the frame.

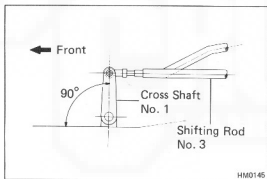

3. ADJUST CROSS SHAFT NO. 1 ANGLE

Adjust shifting rod No. 3 so that cross shaft No. 1 is at right angle to the frame.

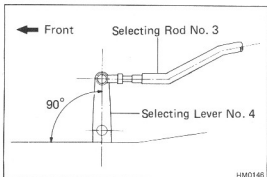

4. ADJUST SELECTING LEVER NO. 4

Adjust selecting rod No. 3 so that selecting lever No. 4 is at right angle to the frame.

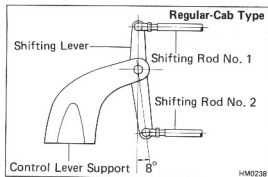

5. ADJUST SHIFTING LEVER ANGLE

[Regular Cab]

Adjust shifting rod No. 2 so that the lower end of the shifting lever is at an 8° angle toward the rear from perpendicular.

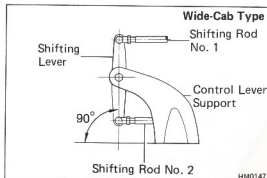

[Wide Cab]

Adjust shifting rod No. 2 so that the shifting lever is at right angle to the frame.

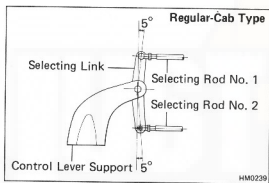

6. ADJUST SELECTING LINK ANGLE

[Regular Cab]

Adjust selecting rod No. 2 so that the ends of the selecting link are at a 5° angle toward the rear from perpendicular.

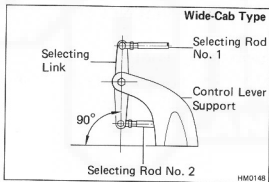

[Wide Cab]

Adjust selecting rod No. 2 so that the selecting link is at right angle to the frame.

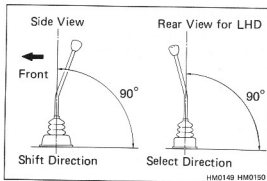

7. ADJUST SHIFT LEVER NEUTRAL POSITION

Adjust shifting rod No. 1 and selecting rod No. 1 so that the lower straight part of the shift lever is perpendicular to the floor.

REMOTE CONTROL (DYNA COLUMN SHIFT SERIES) COMPONENTS

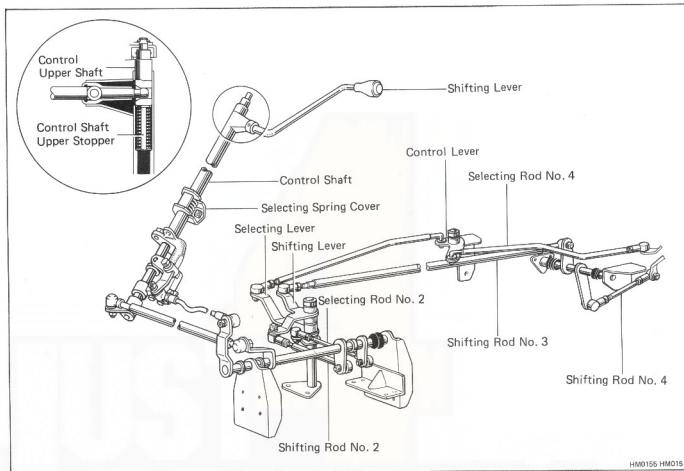

HM0155 HM0151

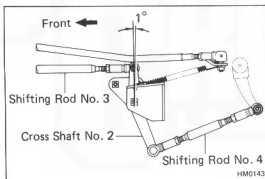

HM0143

ADJUSTMENT OF SHIFT LEVER NEUTRAL POSITION

1. ADJUST CROSS SHAFT NO. 2 ANGLE

Adjust shifting rod No. 4 so that cross No. 2 on the shifting rod No. 3 side is 1° from perpendicular position.

2. ADJUST CONTROL LEVER ANGLE

Adjust selecting rod No. 4 so that the control lever on the selecting rod No. 3 side is at right angle to the frame.

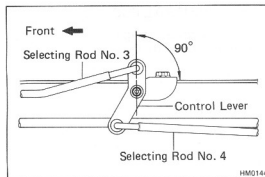

HM0144

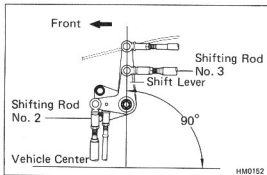

3. ADJUST SHIFTING LEVER ANGLE

Adjust shifting rod No. 3 so that the shifting lever on the shifting rod No. 3 side is at right angle to the center line of the vehicle.

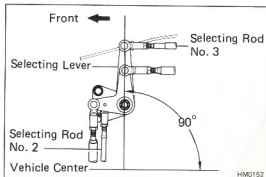

4. ADJUST SELECTING LEVER ANGLE

Adjust selecting rod No. 3 so that the selecting lever on the selecting rod No. 3 side is at right angle to the center line of the vehicle.

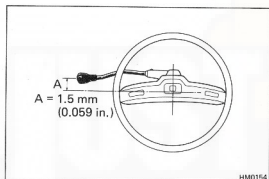

5. ADJUST SHIFT LEVER NEUTRAL POSITION

(a) Shift direction adjustment.

Adjust shifting rod No. 2, so the shift lever is positioned shown in the figure.

(b) Select direction adjustment

- Loosen the select spring cover bolts on the steering column tube.
- Adjust selecting rod No. 2 so that there is no clearance between the control shaft upper stopper and control upper shaft.
- Check the shift lever position is as shown in the figure.
- Adjust the select spring cover so that there is no clearance between the spring stopper on the control shaft and the seat.
- Tighten the select spring cover bolts.

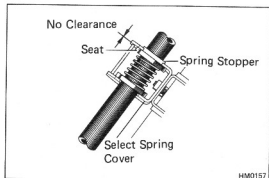
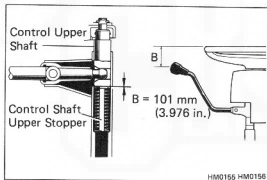

TRANSFER

	Page
TRANSFER	TF-2
Components	TF-2
Disassembly of Transfer	TF-4
Inspection of Transfer Components	TF-9
Assembly of Transfer	TF-15

TF

TRANSFER COMPONENTS

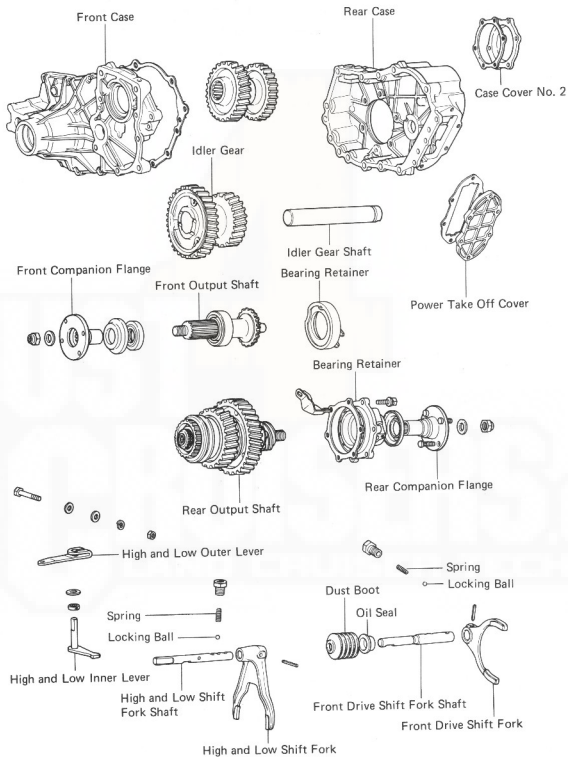

COMPONENTS (Cont'd)

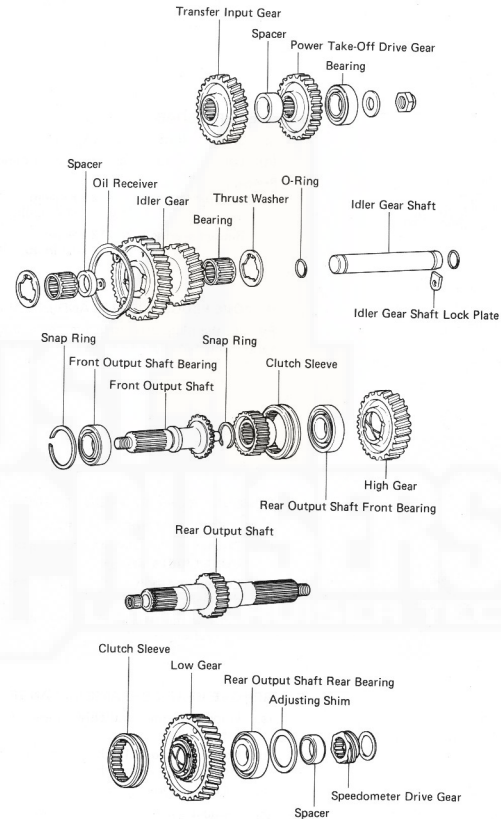

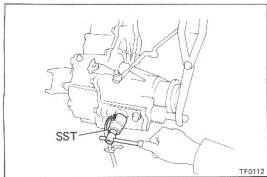

TF0112

DISASSEMBLY OF TRANSFER

1. REMOVE SPEEDOMETER DRIVEN GEAR
2. REMOVE TRANSFER INDICATOR SWITCH
Using SST, remove the transfer indicator switch.
SST 09817-16011

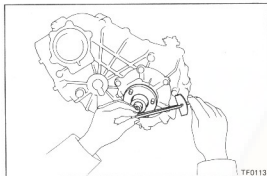

TF0113

3. CHECK PRELOAD
 - (a) Shift the shift lever into N position.
 - (b) Using a torque meter, measure the preload (starting).
 Preload:

New bearing	15 – 24.7 kg-cm (13.0 – 21.4 in.-lb, 1.5 – 2.4 N-m)
Reused bearing	7 – 12 kg-cm (6.1 – 10.4 in.-lb, 0.7 – 1.2 N-m)

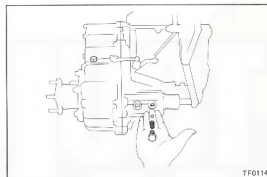

TF0114

4. REMOVE PLUGS, SPRINGS AND LOCKING BALLS
Remove the plugs and, using a magnetic finger, remove the springs and locking balls.

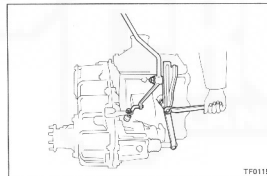

TF0115

5. REMOVE TRANSFER FRONT DRIVE SHAFT LEVER
 - (a) Shift the shift lever to L4 position.
 - (b) Disconnect the high and low shift rod end from the transfer shift outer lever.
 - (c) Loosen the bolt and nut, and remove the transfer shift lever guide.
 - (d) Remove the transfer shift lever subassembly from the support shaft.

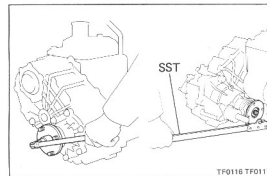

TF0116 TF0117

6. REMOVE REAR COMPANION FLANGE
 - (a) Using a hammer and chisel, loosen the staked part of the nut.
 - (b) Using SST to hold the front companion flange, remove the nut and washer.
SST 09330-00020
 - (c) Remove the rear companion flange.

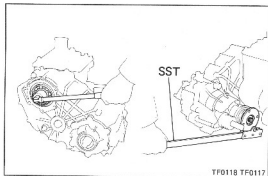

7. REMOVE TRANSFER CASE COVER NO. 2 AND TRANSMISSION OUTPUT SHAFT LOCK NUT

- (a) Remove the six bolts, and remove the transfer case cover No. 2.
- (b) Using a hammer and chisel, loosen the staked part of the nut.
- (c) Using SST to hold the front companion flange, remove the transmission output shaft lock nut.

SST 09330-00020

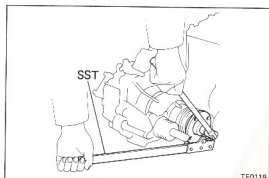

8. REMOVE FRONT COMPANION FLANGE

- (a) Using a hammer and chisel, loosen the staked part of the nut.
 - (b) Use SST to hold the front companion flange.
- SST 09330-00020
- (c) Remove the front companion flange.

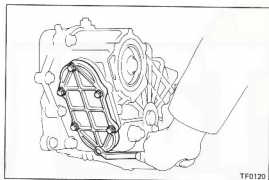

9. REMOVE POWER TAKE-OFF COVER

Remove the six bolts, and remove the power take-off cover.

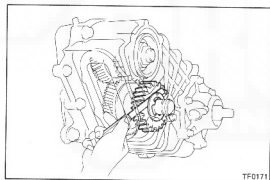

10. MEASURE IDLER GEAR THRUST CLEARANCE

Using a feeler gauge, measure the clearance between the idler gear and thrust washer.

Standard clearance: 0.28 – 0.62 mm
(0.0110 – 0.0244 in.)

Maximum clearance: 0.62 mm (0.0244 in.)

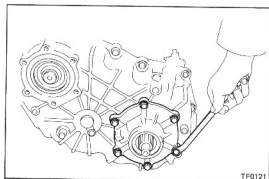

11. REMOVE REAR OUTPUT SHAFT REAR BEARING RETAINER

- (a) Remove the six bolts, and remove the rear output shaft rear bearing retainer.
- (b) Remove the speedometer drive gear and spacer.

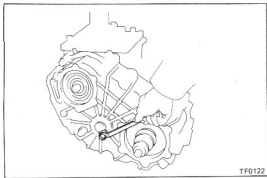

12. REMOVE IDLER GEAR SHAFT LOCK PLATE

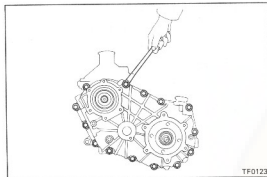

13. REMOVE TRANSFER REAR CASE

- (a) Remove the bolts.
- (b) Using a plastic hammer, remove the transfer rear case.

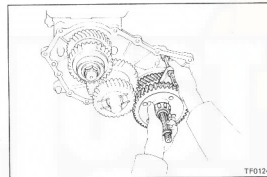

14. REMOVE REAR OUTPUT SHAFT ASSEMBLY WITH SHIFT FORK AND SHIFT FORK SHAFT

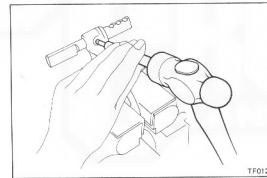

15. REMOVE SHIFT FORK SHAFT

- (a) Using a pin punch and hammer, drive out the slotted spring pin.
 - (b) Remove the shift fork shaft from the shift fork.
- NOTE: Use a set of soft jaws in the vise to protect the shift fork.

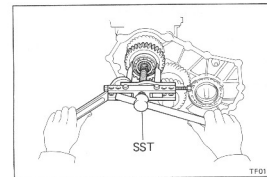

16. REMOVE TRANSFER INPUT GEAR BEARING, POWER TAKE-OFF DRIVE GEAR AND SPACER

- (a) Using SST, remove the transfer input gear bearing.
SST 09950-20015
- (b) Remove the power take-off drive gear and the spacer.

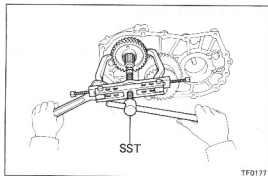
**17. REMOVE TRANSFER INPUT GEAR**

Using SST, remove the transfer input gear.
SST 09950-20015

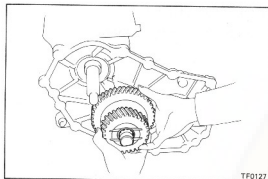
**18. REMOVE IDLER GEAR, BEARINGS, SPACER AND IDLER GEAR SHAFT**

- (a) Remove the O-ring.
- (b) Remove the idler gear, bearing and spacer.
- (c) Remove the idler gear shaft.

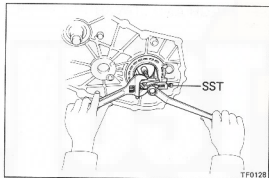
**19. REMOVE REAR OUTPUT SHAFT FRONT BEARING RETAINER**

Using SST, remove the output shaft front bearing retainer.
SST 09308-10010

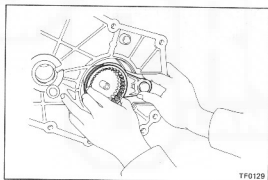
**20. REMOVE CLUTCH SLEEVE**

Remove the clutch sleeve with the shift fork and shift fork shaft.

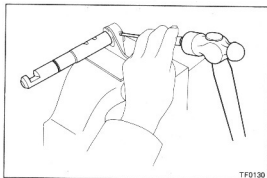
**21. REMOVE SHIFT FORK SHAFT**

- (a) Using a pin punch and hammer, drive out the slotted spring pin.
- (b) Remove the shift fork shaft from the shift fork.

NOTE: Use a set of soft jaws in the vise to protect the shift fork.

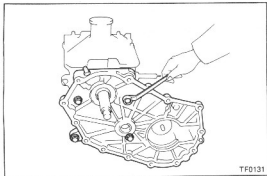
**22. REMOVE TRANSFER FRONT CASE**

- (a) Remove the four bolts.
- (b) Using a plastic hammer, remove the transfer front case.

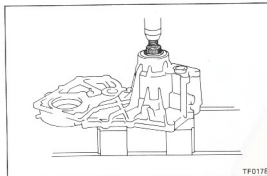
**23. REMOVE FRONT OUTPUT SHAFT**

Using a press, remove the front output shaft.

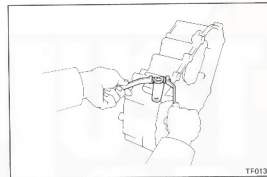
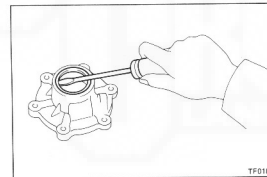
**24. REMOVE TRANSFER HIGH AND LOW SHIFT OUTER AND INNER LEVER****25. REMOVE REAR OUTPUT SHAFT OIL SEAL**

Using a screwdriver, remove the oil seal.

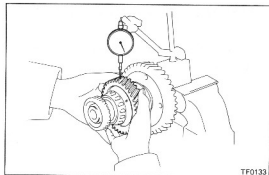

INSPECTION OF TRANSFER COMPONENTS

1. CHECK OIL CLEARANCE AND THRUST CLEARANCE OF TRANSFER HIGH GEAR

- (a) Using a dial indicator, measure the oil clearance between the gear and shaft.

Standard clearance: 0.035 – 0.081 mm
(0.0014 – 0.0032 in.)

Maximum clearance: 0.081 mm (0.0032 in.)

- (b) Using a feeler gauge, measure the thrust clearance.

Standard clearance: 0.10 – 0.25 mm
(0.0039 – 0.0098 in.)

Maximum clearance: 0.25 mm (0.0098 in.)

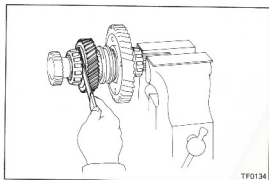

2. CHECK OIL CLEARANCE AND THRUST CLEARANCE OF TRANSFER LOW GEAR

- (a) Using a dial indicator, measure the oil clearance between the gear and shaft.

Standard clearance: 0.035 – 0.081 mm
(0.0014 – 0.0032 in.)

Maximum clearance: 0.081 mm (0.0032 in.)

- (b) Using a feeler gauge, measure the thrust clearance.

Standard clearance: 0.10 – 0.25 mm
(0.0039 – 0.0098 in.)

Maximum clearance: 0.25 mm (0.0098 in.)

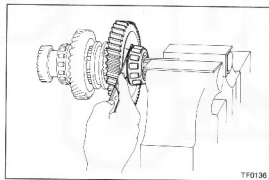
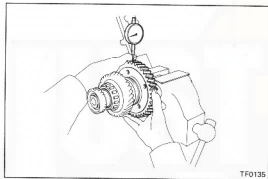

3. MEASURE CLEARANCE OF SHIFT FORKS AND HUB SLEEVES

Using a feeler gauge, measure the clearance between the hub sleeves and shift fork.

Standard clearance: 0.1 – 0.4 mm (0.004 – 0.016 in.)

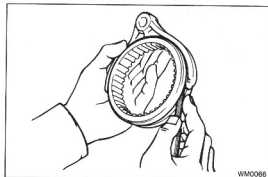

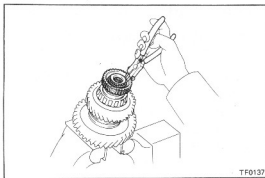

4. IF NECESSARY, REPLACE REAR OUTPUT SHAFT BEARINGS

- (a) Using a snap ring pliers, remove the snap ring.

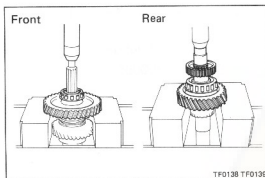

- (b) Using a press, remove the HI and LO gears and bearings.

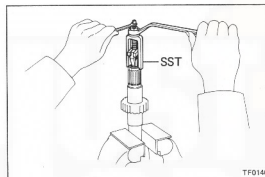

- (c) Using SST, remove the output shaft pilot bearing.

SST 09319-60020

NOTE: The bearing will break.

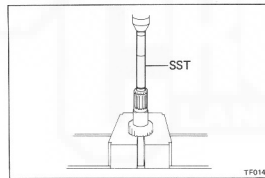

- (d) Using SST, press in a new pilot bearing.

SST 09316-60010

- (e) Apply MP grease to the pilot bearing.

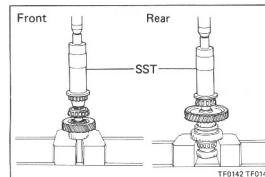

- (f) Using SST, press in a new bearing.

SST 09316-60010

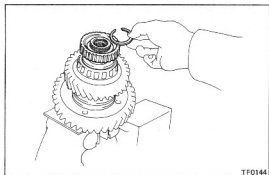

TF0144

- (g) Select a snap ring that will allow minimum axial play and install it on the shaft.

Mark	Thickness	mm (in.)
11	2.30 – 2.35	(0.0906 – 0.0925)
17	2.60 – 2.65	(0.1024 – 0.1043)

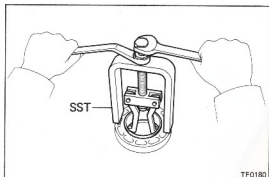

TF0180

- (h) Using SST, remove the rear output shaft front bearing outer race.

SST 09514-35011

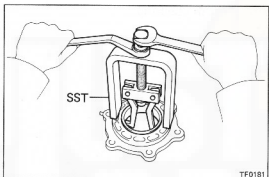

TF0181

- (i) Using SST, remove the rear output shaft rear bearing outer race and shim.

SST 09514-35011

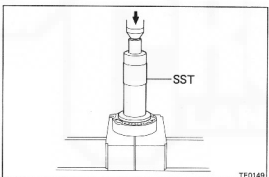

TF0149

- (j) Using SST, press a new front outer race into the front bearing retainer.

SST 09316-60010

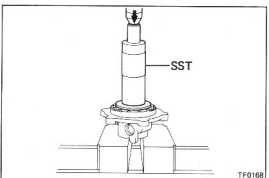

TF0168

- (k) Install the thinnest shim into the rear bearing retainer.

- (l) Using SST, press in a new rear outer race to the rear bearing retainer.

SST 09316-60010

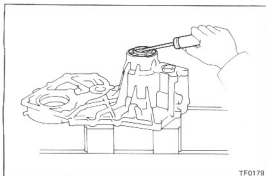

5. IF NECESSARY, REPLACE FRONT OUTPUT SHAFT BEARING AND OIL SEAL

(a) Using a screwdriver, remove the oil seal.

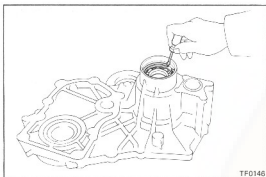

(b) Using a screwdriver, remove the snap ring.

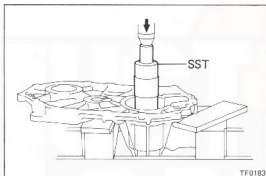

(c) Using SST, press out the bearing.
SST 09316-60010

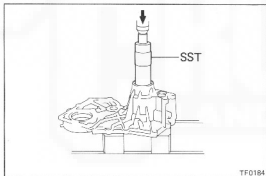

(d) Using SST, press in a new bearing.
SST 09316-60010
(e) Install the snap ring.

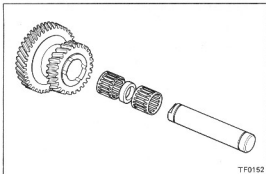

TF0152

6. INSPECT IDLER GEAR BEARING AND SHAFT

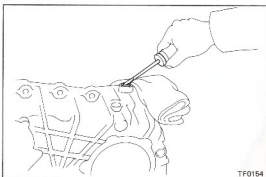

TF0154

7. INSPECT HIGH AND LOW GEAR SELECT LEVER OIL SEAL

- (a) Check for damage.
- (b) Check the oil seal lip for wear or damage.

8. IF NECESSARY, REPLACE HIGH AND LOW GEAR SELECT LEVER OIL SEAL

- (a) Using a screwdriver, remove the oil seal.
- (b) Using SST and hammer, drive in a new oil seal.
SST 09608-20011
- (c) Apply MP grease to the oil seal.

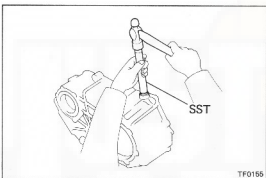

TF0155

9. INSPECT SPEEDOMETER DRIVEN GEAR OIL SEAL

- (a) Check for damage.
- (b) Check the oil seal lip for wear or damage.

10. IF NECESSARY, REPLACE SPEEDOMETER DRIVEN GEAR OIL SEAL

- (a) Using SST, pull out the oil seal.
SST 09921-00010

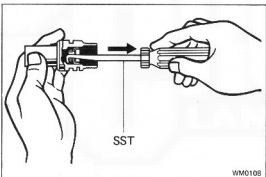

WM0108

- (b) Using SST, drive a new oil seal into the sleeve.
SST 09201-60011

Oil seal depth: 20 mm (0.79 in.)

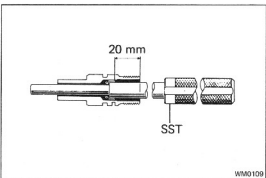

WM0109

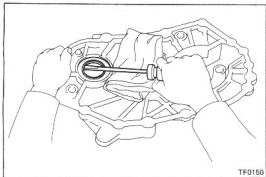

TF0150

11. IN NECESSARY, REPLACE TRANSMISSION REAR OIL SEAL

(a) Using a screwdriver, remove the transmission rear oil seal.

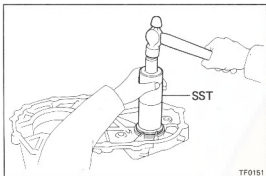

TF0151

(b) Using SST, drive in a new oil seal.
SST 09316-60010

(c) Apply MP grease to the oil seal.

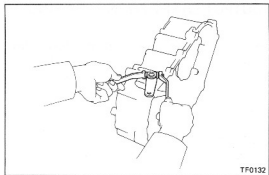

TF0132

ASSEMBLY OF TRANSFER

(See pages TF-2, 3)

- 1. INSTALL TRANSFER HIGH AND LOW SHIFT OUTER AND INNER LEVER**

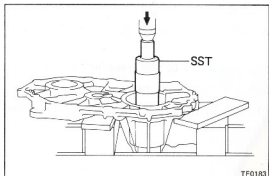

TF0183

- 2. INSTALL FRONT OUTPUT SHAFT**

Using SST, press in the front output shaft to the transfer front case.

SST 09316-60010

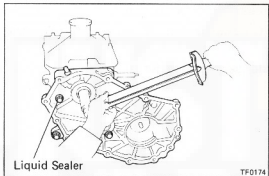

Liquid Sealer

TF0174

- 3. INSTALL TRANSFER FRONT CASE**

- Apply MP grease to the oil seal.
- Install the front case with a new gasket to the transfer adapter.
- Apply liquid sealer to the bolt, and install and torque as shown.
- Install and torque the other bolts.

Torque: 650 kg-cm (47 ft-lb, 64 N-m)

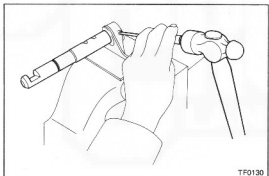

TF0130

- 4. INSTALL SHIFT FORK SHAFT**

- Install the shift fork shaft into shift fork No. 1.
- Using a pin punch and a hammer, drive in the slotted spring pin.

NOTE: Use a set of soft jaws in the vise to protect the shift fork.

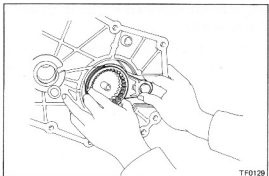

TF0129

- 5. INSTALL CLUTCH SLEEVE WITH SHIFT FORK NO. 1 AND SHAFT**

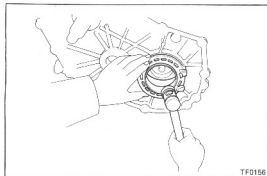

TF0156

6. INSTALL REAR OUTPUT SHAFT FRONT BEARING RETAINER

Using a plastic hammer, install the rear output shaft front bearing retainer.

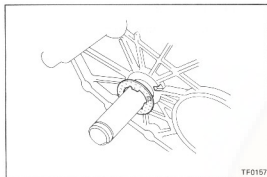

TF0157

7. INSTALL IDLER GEAR

- Install a new O-ring on the idler gear shaft front side groove.
- Install the idler gear shaft to the transfer front case.
- Install the idler gear thrust washer.

NOTE: Be sure that protruding part of washer fits in the case groove.

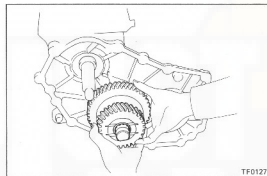

TF0127

- Apply MP grease to the two bearings.
- Install the two bearings and spacer to the idler gear shaft.
- Install the idler gear to the idler gear shaft.

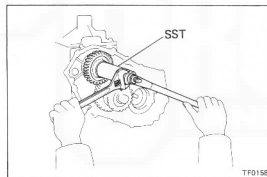

TF0158

8. INSTALL TRANSFER INPUT GEAR

Using SST, install the transfer input gear.
SST 09309-36032

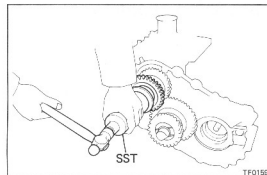

TF0159

9. INSTALL SPACER, POWER TAKE-OFF DRIVE GEAR AND INPUT GEAR BEARING

- Install the spacer and power take-off gear.
- Using SST and hammer, drive in a new input gear bearing.

SST 09316-60010

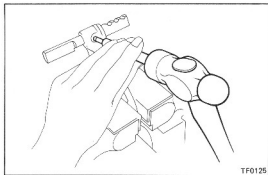

TF0125

10. INSTALL SHIFT FORK SHAFT

- (a) Install the shift fork shaft into shift fork No. 2.
- (b) Using a pin punch and a hammer, drive in the slotted spring pin.

NOTE: Use a set of soft jaws in the vise to protect the shift fork.

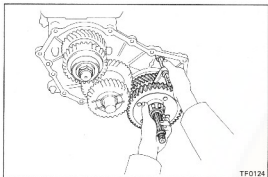

TF0124

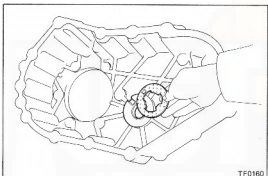
11. INSTALL REAR OUTPUT SHAFT WITH SHIFT FORK AND SHAFT

TF0160

12. STICK ON THRUST WASHER

Stick the thrust washer to the transfer rear case with MP grease.

NOTE: Be sure that protruding part of washer fits in the case groove.

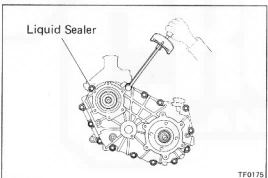

TF0175

13. INSTALL TRANSFER REAR CASE

- (a) Place a new gasket on the front case.
- (b) Install the rear case.
- (c) Apply liquid sealer to the bolt as shown.
- (d) Install and torque the bolts.

Torque:

17 mm 650 kg-cm (47 ft-lb, 65 N-m)

14 mm 400 kg-cm (29 ft-lb, 39 N-m)

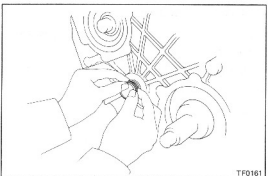

TF0181

14. INSTALL O-RING AND LOCK PLATE

- (a) Align the shaft groove to the bolt hole.
- (b) Install an O-ring on the shaft groove.
- (c) Using a plastic hammer, drive in the shaft.
- (d) Install the lock plate and bolt. Tighten the bolt.

Torque: 150 kg-cm (11 ft-lb, 15 N-m)

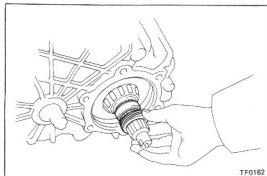

15. INSTALL SPEEDOMETER DRIVE GEAR AND SPACER

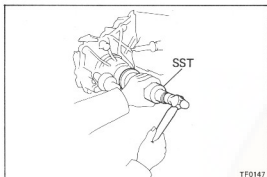

16. INSTALL FRONT OUTPUT SHAFT OIL SEAL

Using SST and a hammer, drive in a new oil seal.
SST 09316-60010

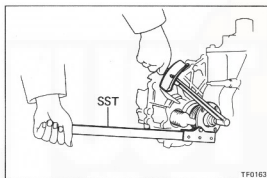

17. INSTALL FRONT COMPANION FLANGE

- (a) Install the front companion flange to the output shaft.
- (b) Using SST to hold the flange, install the washer and a new nut. Torque the nut.

SST 09330-00020

Torque: 1,300 kg-cm (94 ft-lb, 127 N-m)

- (c) Stake the nut.

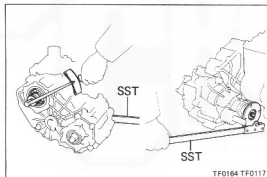

18. INSTALL TRANSMISSION OUTPUT SHAFT LOCK NUT

- (a) Shift the transfer shift lever into 4L position.
- (b) Using SST to hold the front companion flange, install the washer and a new nut. Torque the nut.

SST 09330-00020

Torque: 1,300 kg-cm (94 ft-lb, 127 N-m)

- (c) Stake the nut.

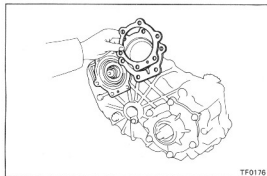

19. INSTALL TRANSFER CASE COVER NO. 2

- (a) Install transfer case cover No. 2 with a new gasket to the transfer rear case.
- (b) Apply liquid sealer to the six bolts.
- (c) Install and torque the bolts.

Torque: 165 kg-cm (12 ft-lb, 16 N-m)

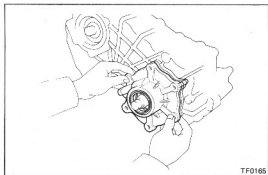

TF0166

20. MEASURE REAR OUTPUT SHAFT PRELOAD

- (a) Install the rear output shaft rear bearing retainer.
- Align the bearing retainer rib with the case.
 - Install and torque the bolts.

Torque: 350 kg-cm (25 ft-lb, 34 N-m)

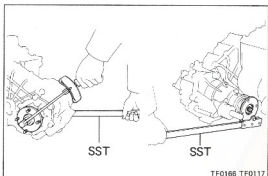

TF0166 TF0117

- (b) Install the rear companion flange.
- Install the rear companion flange to the output shaft.
 - Using SST to hold the front companion flange, install the washer and nut. Torque the nut.

SST 09330-00020

Torque: 1,300 kg-cm (94 ft-lb, 127 N-m)

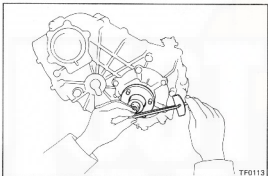

TF0113

- (c) Shift the transfer shift lever to the N position.
- (d) Using a torque meter, measure the rear output shaft preload (Starting torque).

Preload:

New bearing	15 – 24.7 kg-cm (13.0 – 21.4 in.-lb, 1.5 – 2.4 N-m)
Reused bearing	7 – 12 kg-cm (6.1 – 10.4 in.-lb, 0.7 – 1.2 N-m)

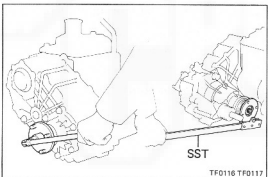

TF0116 TF0117

21. IF NECESSARY ADJUST REAR OUTPUT SHAFT PRELOAD

- (a) Remove the rear companion flange.
- Use SST to hold the front companion flange.
 - Remove the rear companion flange.

SST 09330-00020

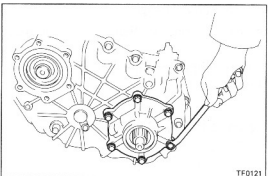

TF0121

- (b) Remove the rear output shaft rear bearing retainer.

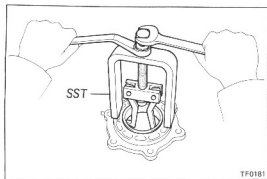

- (c) Using SST, remove the output shaft rear bearing outer race and shim.

SST 09514-35011

- (d) Select a shim.

Mark	Thickness mm (in.)	Mark	Thickness mm (in.)
0	0.15 (0.0059)	10	1.0 (0.039)
4	0.4 (0.016)	11	1.1 (0.043)
5	0.5 (0.020)	12	1.2 (0.047)
6	0.6 (0.024)	13	1.3 (0.051)
7	0.7 (0.028)	14	1.4 (0.055)
8	0.8 (0.031)	15	1.5 (0.059)
9	0.9 (0.035)		

NOTE: The preload will change about 10.0 kg-cm (8.7 in.-lb, 1.0 N-m) with each shim thickness.

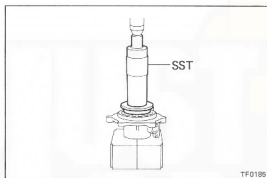

- (e) Using SST, press in the bearing outer race and shim.

SST 09316-60010

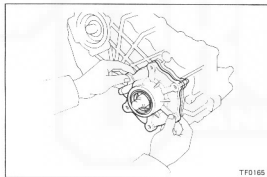

- (f) Install the rear output shaft rear bearing retainer.

- Align the bearing retainer rib with the case rib and install the retainer with a new gasket.
- Install and torque the bolts.

Torque: 350 kg-cm (25 ft-lb, 34 N-m)

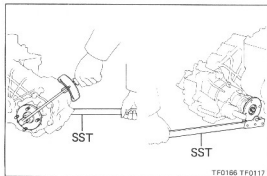

- (g) Install the rear companion flange.

- Install the rear companion flange to the output shaft.
- Using SST to hold the front companion, install the washer and nut.

SST 09330-00020

Torque: 1,300 kg-cm (94 ft-lb, 127 N-m)

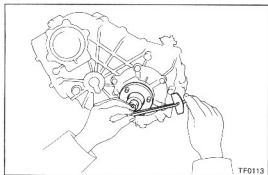

- (h) Measure the rear output shaft preload.
- Using a torque meter, measure the rear output shaft preload.

Preload:

New bearing	15 – 24.7 kg-cm (13.0 – 21.4 in.-lb, 1.5 – 2.4 N-m)
Reused bearing	7 – 12 kg-cm (6.1 – 10.4 in.-lb, 0.7 – 1.2 N-m)

- (i) If necessary, adjust the output shaft preload again.

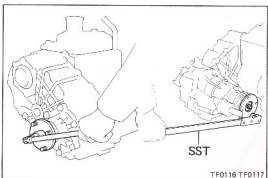
**22. REMOVE REAR COMPANION FLANGE**

- (a) Use SST to hold the front companion flange.
(b) Remove the rear companion flange.

SST 09330-00020

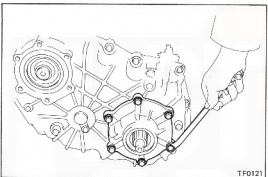
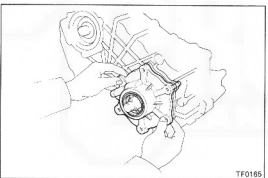
**23. REMOVE REAR OUTPUT SHAFT REAR BEARING RETAINER****24. INSTALL REAR OUTPUT SHAFT REAR BEARING RETAINER**

- (a) Align the bearing retainer rib with the case rib and install the retainer with a new gasket.
(b) Apply liquid sealer to the six bolts.
(c) Install and torque the bolts.

Torque: 350 kg-cm (25 ft-lb, 34 N-m)

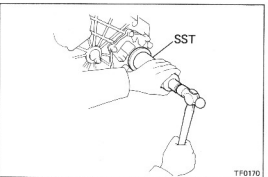
**25. INSTALL REAR OUTPUT SHAFT OIL SEAL**

Using SST and a hammer, drive in a new rear output shaft oil seal.

SST 09316-60010

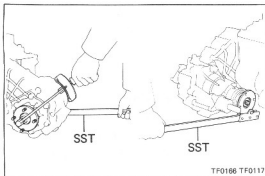
**26. INSTALL REAR COMPANION FLANGE**

- (a) Install the companion flange to the rear output shaft.
- (b) Using SST to hold the front companion flange, install the washer and a new nut. Torque the nut.

SST 09330-00020

Torque: 1,300 kg-cm (94 ft-lb, 127 N-m)

- (c) Stake the nut.

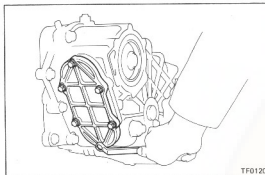
**27. INSTALL POWER TAKE-OFF COVER**

- (a) Install the power take-off cover with a new gasket to the transfer rear case.
- (b) Apply liquid sealer to the bolt, as shown, and install and torque the bolts.

Torque: 170 kg-cm (12 ft-lb, 17 N-m)

- (c) Install and torque the other bolts.

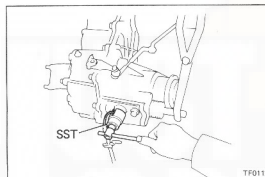
Torque: 185 kg-cm (13 ft-lb, 18 N-m)**28. INSTALL TRANSFER INDICATOR SWITCH**

Using SST, install and torque the transfer indicator switch.

SST 09817-16011

Torque: 450 kg-cm (33 ft-lb, 44 N-m)

SERVICE SPECIFICATIONS

	Page
MANUAL TRANSMISSION	A-2
TRANSFER	A-4



MANUAL TRANSMISSION

Specifications

Output shaft				
1st and 2nd gear journal diameter	Limit	43.93 mm	1.7295 in.	
Runout	Limit	0.03 mm	0.0012 in.	
3rd gear bushing outer diameter	Limit	45.85 mm	1.8051 in.	
1st and 2nd gear inner diameter	Limit	50.10 mm	1.9724 in.	
3rd gear inner diameter	Limit	46.07 mm	1.8138 in.	
Counter gear				
5th gear journal diameter	Limit	31.93 mm	1.2571 in.	
Rear bearing journal diameter	Limit	39.00 mm	1.5354 in.	
Counter 5th gear inner diameter	Limit	39.07 mm	1.5382 in.	
Reverse idler gear inner diameter	Limit	30.10 mm	1.1850 in.	
Reverse shift arm shoe to idler groove clearance	Limit	0.7 mm	0.028 in.	
Reverse shift arm shoe thickness		8.1 mm	0.319 in.	
Gear thrust clearance				
1st and 2nd	STD	0.175 – 0.325 mm	0.0069 – 0.0128 in.	
	Limit	0.35 mm	0.0138 in.	
3rd	STD	0.125 – 0.275 mm	0.0049 – 0.0108 in.	
	Limit	0.30 mm	0.0118 in.	
Counter 5th	STD	0.10 – 0.30 mm	0.0039 – 0.0118 in.	
	Limit	0.30 mm	0.0118 in.	
Gear oil clearance				
1st and 2nd	STD	0.020 – 0.073 mm	0.0008 – 0.0029 in.	
	Limit	0.08 mm	0.0031 in.	
3rd	STD	0.065 – 0.115 mm	0.0026 – 0.0045 in.	
	Limit	0.12 mm	0.0047 in.	
Counter	STD	0.015 – 0.068 mm	0.0006 – 0.0027 in.	
	Limit	0.07 mm	0.0028 in.	
Reverse idle	STD	0.060 – 0.135 mm	0.0024 – 0.0053 in.	
	Limit	0.16 mm	0.0063 in.	
Shift fork to hub sleeve clearance	Limit	0.8 mm	0.031 in.	
Synchronizer ring to gear clearance				
3rd, 4th and 5th	Limit	0.8 mm	0.031 in.	
Synchronizer ring to gear distance				
1st gear	Limit	32.5 mm	1.280 in.	
2nd gear	Limit	38.0 mm	1.496 in.	
Input shaft snap ring thickness				
	Part No.			
	90520-36016	3.20 – 3.31 mm	0.1260 – 0.1303 in.	
	90520-36015	3.31 – 3.42 mm	0.1303 – 0.1346 in.	

Specifications (Cont'd)

Output shaft snap ring thickness			
	Part No.	Mark	
	90520-36250	0	2.40 — 2.45 mm
	90520-36251	1	2.45 — 2.50 mm
	90520-36252	2	2.50 — 2.55 mm
	90520-36253	3	2.55 — 2.60 mm
	90520-36254	4	2.60 — 2.65 mm
	90520-36255	5	2.65 — 2.70 mm
			0.0945 — 0.0965 in.
			0.0965 — 0.0984 in.
			0.0984 — 0.1004 in.
			0.1004 — 0.1024 in.
			0.1024 — 0.1043 in.
			0.1043 — 0.1063 in.
Counter gear snap ring thickness			
	Part No.	Mark	
	90520-30214	0	2.05 — 2.10 mm
	90520-30216	2	2.15 — 2.20 mm
	90520-30218	4	2.25 — 2.30 mm
			0.0807 — 0.0827 in.
			0.0846 — 0.0866 in.
			0.0886 — 0.0906 in.
Oil seal drive in depth			
Speedometer driven gear			20.0 mm
5th shift arm shaft			1.0 mm
			0.787 in.
			0.039 in.
Oil seal installed height (H55F only)			
5th fork shaft oil seal for case cover			4.0 — 4.5 mm
			0.157 — 0.177 in.
Tight plug drive in depth			
Shift lever shaft			1.0 — 2.8 mm
Shift fork shaft			1 — 2 mm
			0.039 — 0.110 in.
			0.04 — 0.08 in.

Tightening Torque

Tightening part	kg-cm	ft-lb	N-m
Center bearing retainer	185	13	18
Front bearing retainer	170	12	17
Counter gear rear lock nut	1,300	94	127
5th shift arm x Shaft	380	27	37
Shift lever shaft x Pressure switch	160	12	16
Shift outer lever lock pin	200	14	20
Select outer lever lock pin	80	69 in.-lb	7.8
Extension housing x Transmission case	600	43	59
Straight screw plug for 5th locking ball and spring	250	18	25
Clutch housing x Transmission case	730	53	72
Case cover x Transmission case			
	H50	530	38
	H41, H42 and H55F	400	29
Shift lever housing x Case cover	195	14	19
Reverse shift arm pivot lock nut	250	18	25
Parking Brake drum lock nut (H50 only)	1,300	94	127

TRANSFER

Specifications

High and low gear oil clearance	STD	0.035 – 0.081 mm	0.0014 – 0.0032 in.
	Limit	0.081 mm	0.0032 in.
High and low gear thrust clearance	STD	0.10 – 0.25 mm	0.0039 – 0.0098 in.
	Limit	0.25 mm	0.0098 in.
Shift fork to hub sleeve clearance	STD	0.1 – 0.4 mm	0.004 – 0.016 in.
Rear output shaft snap ring thickness	Mark		
	11	2.30 – 2.35 mm	0.0906 – 0.0925 in.
	17	2.60 – 2.65 mm	0.1024 – 0.1043 in.
Idler gear thrust clearance	STD	0.28 – 0.62 mm	0.0110 – 0.0244 in.
	Limit	0.62 mm	0.0244 in.
Rear output shaft preload	New bearing	15 – 24.7 kg-cm	(13.0 – 21.4 in.-lb, 1.5 – 2.4 N-m)
	Reused bearing	7 – 12 kg-cm	(6.1 – 10.4 in.-lb, 0.7 – 1.2 N-m)
Rear output shaft preload adjusting shim	Mark		
	0	0.15 mm	0.0059 in.
	4	0.4 mm	0.016 in.
	5	0.5 mm	0.020 in.
	6	0.6 mm	0.024 in.
	7	0.7 mm	0.028 in.
	8	0.8 mm	0.031 in.
	9	0.9 mm	0.035 in.
	10	1.0 mm	0.039 in.
	11	1.1 mm	0.043 in.
	12	1.2 mm	0.047 in.
	13	1.3 mm	0.051 in.
	14	1.4 mm	0.055 in.
	15	1.5 mm	0.059 in.

Tightening Torque









Tightening part	kg-cm	ft-lb	N·m
Transfer front case x Transmission case	650	47	64
Transfer front case x Transfer rear case			
17 mm	650	47	64
14 mm	400	29	39
Idler gear shaft lock plate bolt	150	11	15
Front companion flange lock nut	1,300	94	127
Transfer rear case x Transfer case cover No. 2	165	12	16
Transfer rear case x Rear output shaft rear bearing retainer	350	25	34
Rear companion flange lock nut	1,300	94	127
Transmission output shaft lock nut	1,300	94	127
Transfer rear case x Power take-off cover			
With liquid sealer	170	12	17
Others	185	13	18
Transfer indicator switch	450	33	44

STANDARD BOLT TIGHTENING TORQUE

STANDARD BOLT TIGHTENING TORQUE Page
B-2

STANDARD BOLT TIGHTENING TORQUE

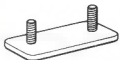
HOW TO DETERMINE BOLT STRENGTH

	Mark	Class		Mark	Class
Hexagon head bolt	 Bolt head No. 4- 5- 6- 7-	4T 5T 6T 7T	Stud bolt	 No mark	4T
	 No mark	4T			
Hexagon flange bolt w/Washer hexagon bolt	 No mark	4T		 Grooved	6T
Hexagon head bolt	 Two protruding lines	5T			
Hexagon flange bolt w/Washer hexagon bolt	 Two protruding lines	6T	Welded bolt		4T
Hexagon head bolt	 Three protruding lines	7T			

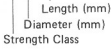
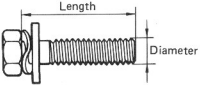
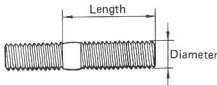
Hexagon bolt	Stud bolt
Example : 9 1 1 1 1 - 4 0 6 2 0 	Example : 9 2 1 3 2 - 4 0 6 2 0 
	















SPECIFIED TORQUE FOR STANDARD BOLTS

Class	Diameter mm	Pitch mm	Tightening torque					
			Hexagon head bolt			Hexagon flange bolt		
			kg-cm	ft-lb	N-m	kg-cm	ft-lb	N-m
4T	6	1	55	48 in.-lb	5.4	60	52 in.-lb	5.9
	8	1.25	130	9	13	145	10	14
	10	1.25	260	19	25	290	21	28
	12	1.25	480	35	47	540	39	53
	14	1.5	760	55	75	850	61	83
	16	1.5	1,150	83	113		—	
5T	6	1	65	56 in.-lb	6.4		—	
	8	1.25	160	12	16		—	
	10	1.25	330	24	32		—	
	12	1.25	600	43	59		—	
	14	1.5	930	67	91		—	
	16	1.5	1,400	101	137		—	
6T	6	1	80	69 in.-lb	7.8	90	78 in.-lb	8.8
	8	1.25	195	14	19	215	16	21
	10	1.25	400	29	39	440	32	43
	12	1.25	730	53	72	810	59	79
	14	1.5		—		1,250	90	123
7T	6	1	110	8	11	120	9	12
	8	1.25	260	19	25	290	21	28
	10	1.25	530	38	52	590	43	58
	12	1.25	970	70	95	1,050	76	103
	14	1.5	1,500	108	147	1,700	123	167
	16	1.5	2,300	166	226		—	







SST

	Page
SST (SPECIAL SERVICE TOOLS)	C-2

SST (SPECIAL SERVICE TOOLS)

Section			MANUAL TRANSMISSION			TRANSFER
			H41, 42	H55F	H50	
Illustration	Part No.	Part Name				
	09201-60011	(Valve Stem Guide Remover & Replacer)			●	●
	09213-27010	(Gear Remover)	●	●	●	
	09304-47010	(Input Shaft Front Bearing Replacer)		●		
	09308-00010	(Oil Seal Puller)			●	
	09308-10010	(Oil Seal Puller)				●
	09309-36032	(Transmission Bearing Replacer)	●	●		●
	09309-36040	(Transmission Bearing Replacer)			●	
	09309-60010	(Extension Pipe)		●		
	09313-30021	(Detent Ball Plug Socket)	●	●	●	
	09316-60010	(Transmission & Transfer Bearing Replacer)	●	●	●	●
	09319-60020	(Output Shaft Needle Roller Bearing Remover)				●
	09326-20011	(Output Shaft Bearing Lock Nut Wrench)	●	●	●	
	09330-00020	(Companion Flange Holding Tool)				●
	09514-35011	(Rear Wheel Bearing Puller)				●

SST (SPECIAL SERVICE TOOLS)

Section		MANUAL TRANSMISSION			TRANSFER
		H41, 42	H55F	H50	
Illustration	Part No. Part Name				
	09515-21010 (Rear Axle Shaft Bearing Replacer)	●			
	09602-10010 (Front Axle Inner Bearing Puller)	●			
	09608-20011 (Front Hub & Drive Pinion Bearing Tool Set)				●
	09817-16011 (Back-up Light Switch Tool)	●	●	●	●
	09910-00015 (Puller Set)	●	●	●	
	09921-00010 (Spring Tension Tool)			●	●
	09950-20015 (Universal Puller)	●	●	●	●



OVERSEAS SERVICE DEPARTMENT
TOYOTA MOTOR CORPORATION
Haruhi Center

PRINTED IN JAPAN ©
01-840405-00
03-841011-01