

# PROJECT MANUAL

## McKay Dee Hospital Pulmonary Clinic Remodel

4401 Harrison Blvd.  
Ogden, UT 84403

Owner  
**Intermountain Health**

## Construction Documents

Date: May 28, 2024

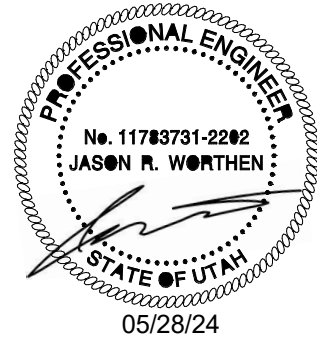
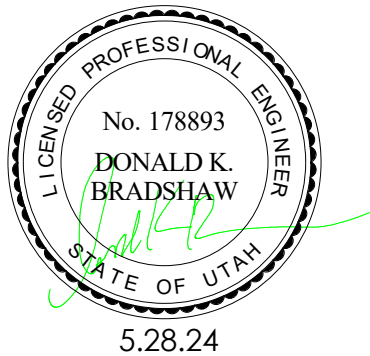
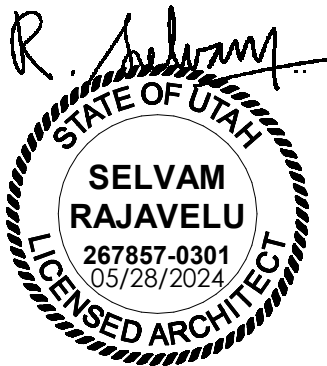

**PROJECT MANUAL INDEX**

Title Page  
Project Manual Index  
Drawing Index

**Bidding and Contract Requirements**

A/E Certificate of Substantial Completion – Intermountain Form  
Application and Certification for Payment  
Intermountain Lien Waiver and Release Form  
Utilities Shutdown Request Form  
Above Ceiling Work Permit Form  
Hot Work Permit Form  
Infection Control Risk Assessment (ICRA)  
Sample – ASI Form  
Sample – CCD Form  
Sample – CO Form  
Sample – PCO Form  
Sample – PR Form  
Sample – RFI Form  
Contractor Orientation  
Construction Safety Requirements  
Intermountain Responsibility Matrix  
Tax Exemption Certificate TC-721  
Bid Form  
Intermountain Healthcare - General Conditions

**Technical Specifications**

**DIVISION 1 - GENERAL REQUIREMENTS**

011000	Summary
012300	Alternates
012900	Payment Procedures
013100	Project Management and Coordination
013110	Field Engineering
013300	Submittal Procedures
014000	Quality Requirements
014373	Schedule of Values
015000	Temporary Facilities and Controls
016000	Product Requirements
017600	Guaranties and Warranties
017700	Closeout Procedures
017823	Operation and Maintenance Data
017839	Project Record Documents
017900	Cleaning

**DIVISION 2 – EXISTING CONDITIONS**

024119 Selective Demolition

**DIVISION 3 - CONCRETE**

035300 Concrete Topping

**DIVISION 5 - METALS**

050500 Metal Fasteners

**DIVISION 6 - WOOD AND PLASTICS**

061000 Rough Carpentry  
064123 Interior Architectural Woodwork

**DIVISION 7 – THERMAL AND MOISTURE PROTECTION**

078100 Spray Applied Fireproofing  
078400.1 Firestopping  
078400.2 Penetration Firestopping – UL Listings  
079200 Joint Sealants

**DIVISION 8 – DOORS AND WINDOWS**

081113 Hollow Metal Doors and Frames  
081416 Flush Wood Doors  
087100 Door Hardware  
088000 Glazing

**DIVISION 9 - FINISHES**

092216.1 Non-Structural Metal Framing  
092216.2 Rated Wall Types – UL Listings  
092220 Acoustical Insulation  
092900 Gypsum Board  
095100 Ceiling Suspension  
095113 Acoustical Panel Ceilings  
096519 Resilient Flooring  
096813 Carpet Tile  
099123 Interior Painting

**DIVISION 10 – SPECIALTIES**

102600 Wall and Door Protection

**Mechanical****DIVISION 21 - FIRE SUPPRESSION**

211000 Water-Based Fire-Suppression Systems

**DIVISION 22 - PLUMBING**

22 05 00 Common Work Results for Plumbing  
22 05 17 Sleeves and Sleeve Seals for Plumbing Piping  
22 05 18 Escutcheons for Plumbing Piping  
22 05 23 General Duty Valves for Plumbing Piping  
22 05 48 Vibration and Seismic Control for Plumbing Piping and Equipment  
22 05 53 Identification for Plumbing Piping and Equipment  
22 07 19 Plumbing Piping Insulation  
22 11 16 Domestic Water Piping  
22 11 19 Domestic Water Piping Specialties  
22 13 16 Sanitary Waste and Vent Piping  
22 13 19 Sanitary Waste Piping Specialties  
22 40 00 Plumbing Fixtures  
22 63 14 Medical Gas Piping

**DIVISION 23 - HEATING, VENTILATING, AND AIR CONDITIONING**

23 01 00 Mechanical Requirements  
23 01 50 Temporary Use of Equipment and Systems  
23 05 00 Common Work Result for HVAC  
23 05 13 Common Motor Requirements for HVAC Equipment  
23 05 17 Sleeves and Sleeve Seals for HVAC Piping  
23 05 18 Escutcheons for HVAC Piping  
23 05 19 Meters and Gages for HVAC  
23 05 23 General-Duty Valves for HVAC Piping  
23 05 29 Hangers and Supports for HVAC Piping and Equipment  
23 05 48 Vibration Isolation and Seismic Restraint  
23 05 50 Operation and Maintenance of HVAC Systems  
23 05 53 Identification for HVAC Piping and Equipment  
23 05 93 Testing Adjusting and Balancing for HVAC  
23 07 13 Duct Insulation  
23 07 19 HVAC Piping Insulation  
23 09 00 Instrumentation and Control for HVAC  
23 21 13 Hydronic Piping  
23 21 16 Hydronic Piping Specialties  
23 30 01 Common Duct Requirements  
23 31 13 Metal Ducts  
23 33 00 Air Duct Accessories  
23 36 00 Air Terminal Units  
23 37 13 Diffusers, Registers, and Grilles

**Electrical****DIVISION 26 – ELECTRICAL**

260519	Low-voltage electrical power conductors and cables
260526	Grounding and bonding for electrical systems
260529	Hangers and supports for electrical systems
260533	Raceways and boxes for electrical systems
260544	Sleeves and sleeve seals for electrical systems
260553	Identification for electrical systems
260923	Lighting control devices
262726	Wiring devices
265119	Led interior lighting

**DIVISION 27 - COMMUNICATIONS**

270000	Common general conditions for communications sections
270100	Operation and maintenance of communication systems
270113	Warranty product and system
270119	Field testing and reporting
270133	Shop drawings product data samples design records and existing conditions
270143	Qualifications and required training for contractor and installer
270171	Responsibility and workmanship of contractor
270500	Common work results for communications
270526	Grounding and bonding for communications systems
270528	Pathways for communications systems
270529	Hangers and supports for communications systems
270533	Conduits and back boxes for communications systems
270536	Cable trays for communications systems
270543	Campus cable routing
270553	Identification for low-voltage cables and labeling
271100	Equipment room fitting
271116	Cabinets, Racks, Frames, and Enclosures
271119	Termination blocks and patch panels
271300	Backbone cabling
271500	Horizontal cabling
271513	Copper cable
271543	Faceplates and connectors
271619	Patch cables
274133	Master antenna television system
275113	Overhead paging
275319	Internal cellular paging and antenna systems
276001	Appendix 01 deviation request process
276002	Appendix 02 document refresh process
276003	Appendix 03 data center, TEC, TDR part numbers
276004	Appendix 04 reference standards
276005	Appendix 05 definitions and abbreviations
276006	Appendix 06 material suppliers

276007 Appendix 07 Siemon - certified installation firms  
276008 Appendix 08 Lead wall penetrations

**DIVISION 28 - ELECTRONIC SAFETY AND SECURITY**

283111 Digital, addressable fire-alarm system

**DRAWING INDEX****General Drawings**

G001	Cover Sheet
G002	General Information
G003	General Information
G004	American National Standard Institute Requirements
G005	General Legend & Notes
G111	Code Compliance Plan Level 4

**Architectural Drawings**

A111	Demolition Floor Plan Level 4
A112	Demolition Ceiling Plan Level 4
A113	Floor Plan Level 4
A116	Reflected Ceiling Plan Level 4
A117	Finish Plan Level 4
A251	Interior Elevations
A501A	Wall Types
A502A	Wall Details
A502B	Wall Details
A503A	Ceiling Details
A504A	Door & Window Details
A505A	Cabinet Legend & Details
A601A	Door Schedule
A603A	Finish Schedule & Details

**Mechanical Drawings**

M000	Mechanical Title Sheet
M001	Mechanical General Notes
M011	Level 1 Thermal Zone Plan
MD101	Level 4 Mechanical Demolition
M101	Level 4 HVAC Plan
MD111	Level 4 Mechanical Piping Demolition Plan
M111	Level 4 Mechanical Piping Plan

**Plumbing Drawings**

P000	Plumbing Title Sheet
PD100	Level 3 Plumbing Demolition Plan
PD101	Level 4 Plumbing Demolition Plan
P100	Level 3 Plumbing Plan
P101	Level 4 Plumbing Plan
P501	Plumbing Details
P601	Plumbing Schedules

**Electrical Drawings**

EE001	Electrical Cover Sheet
EE002	Telecom Schedules and Notes
EE501	Electrical Details
EE701	Typical Mounting Details
ED101	Level 4 Electrical Demolition Plan

ED102	Level 4 Ceiling Demolition Plan
EP101	Level 4 Power Plan
EP551	Telecom Details
EP650	Telecom Conduit Riser Diagrams
EL101	Level 4 Lighting Plan
EL601	Lighting Schedules
EY101	Level 4 Auxiliary Plan



## A/E CERTIFICATE OF SUBSTANTIAL COMPLETION

<b>Project Name:</b>	<b>Project Name Address City, State, Zip</b>	<b>Intermountain Health:</b>	<b>IHC Health Services, Inc. 36 South State Street, 21<sup>st</sup> Flr Salt Lake City, Utah, 84111</b>
<b>Intermountain Health Project No:</b>	<b>1001XXXX</b>		
<b>Contractor:</b>	<b>Name Address City, State, Zip</b>	<b>A/E:</b>	<b>Name Address City, State, Zip</b>
<b>Agreement For:</b>	<b>Construction</b>	<b>Certificate Number:</b>	<b>Enter No. (e.g., BP001)</b>
<b>Agreement Date:</b>	<b>DD/MM/YEAR</b>	<b>DATE OF SUBSTANTIAL COMPLETION:</b>	<b>DD/MM/YEAR</b>

**THE DEFINITION OF SUBSTANTIAL COMPLETION** is the stage in the progress of the Work when the Project Work or designated portion of the Project is sufficiently complete in accordance with the Contract Documents so Intermountain Health can occupy and utilize the Project Work for its intended use. The Project Work, or designated portion of the Project, identified and described below has been reviewed and found, to the A/E's best knowledge, information, and belief, to be substantially complete.

*(A/E to identify the Project Work, or designated portion of the Project, that is substantially complete)*  
A/E to enter Project Work text here.

### WARRANTIES

The **DATE OF SUBSTANTIAL COMPLETION** of the Project Work or portion designated above is the date established by this Certificate, which is also the date of commencement of applicable warranties required by the Contract Documents, except as stated below:

*(A/E to identify warranties that do not commence on the date of Substantial Completion, if any, and indicate their date of commencement)*  
A/E to enter N/A, None, or additional text here.

### WORK TO BE COMPLETED OR CORRECTED

A list of Project Work items to be completed or corrected has been prepared by the Contractor and provided to the A/E. This list has been reviewed, amended, and additional Project Work items have been documented by the A/E. This list is attached hereto or included by reference. The failure to include any Project Work items does not alter the responsibility of the Contractor to complete all Project Work in accordance with the Contract Documents. This Certificate is subject to provisions of the A/E's Project Manual substitution section and does not include items noted as unacceptable or nonconforming.

*(A/E to identify the list of Project Work to be completed or corrected)*  
A/E to enter text or See attached Punch List as applicable.

The date of commencement of warranties for **WORK TO BE COMPLETED OR CORRECTED** items on the attached list will be the date of the final Intermountain Health approval of the Contractor's final Application and Certification For Payment, unless otherwise agreed to in writing.





APPLICATION AND CERTIFICATION FOR PAYMENT

To Owner: IHC Health Services, Inc. Owner Project #: Owner Project #
36 South State Street Application #: 1
Salt Lake City, UT 84111 Application Date: 12/1/2018
From Contractor: Contractor Name Architect Name Address Address
City, State, Zip City, State, Zip
Via A/E:
Contract Invoice #: 1
Project Name: Project Name Contract Date: 12/17/2016

CONTRACTOR'S APPLICATION FOR PAYMENT

Application is made for payment, as shown below, in connection with the Contract. The Continuation Sheet is attached.

Table with 2 columns: Description and Amount. Rows include: 1. Original Contract Sum (\$100.00), 2. Total Contract Change By Change Orders (\$0), 3. Current Contract Sum (\$100.00), 4. Total Completed & Stored To Date (\$75.00, 75.00%), 5. Retention (5.1-5.6), 6. Total Earned Less Retainage (\$71.25), 7. Less Previous Certificates For Payments (\$0, 0.00%), 8. Current Payment Due (\$23.75, 23.75%), 9. Balance To Finish, Plus Retention (\$76.25, 76.25%).

CONTRACTOR'S CONTRACTOR NAME

The undersigned Contractor certifies that to the best of the Contractor's knowledge, information and belief the Work covered by this Application for Payment has been completed in accordance with the Contract Documents, that all amounts have been paid by the Contractor for Work for which previous Certificates for Payment were issued and payments received from the Owner, and that current payment shown herein is now due.

By: John Doe Date: 12/31/2018

State of:
Subscribed and sworn to before me this \_\_\_ day of \_\_\_
Notary Public:
My Commission Expires: \_\_\_

A/E'S CERTIFICATE FOR PAYMENT

In accordance with the Contract Documents, based upon on-site observations and the data comprising the application, the A/E certifies to the Owner that to the best of the A/E's knowledge, information and belief the Work has progressed as indicated, the quality of the Work is in accordance with the Contract Documents, and the Contractor is entitled to payment of the Amount Certified.

Amount Certified: \$23.75

A/E:
By: Date:

This Certificate is not negotiable. The amount certified is payable only to the Contractor named herein. Issuance, payment and acceptance of payment are without prejudice to any rights of the Owner or Contractor under this Contract.

Approved by FD&C PM 1,2: (Signature) (Date)

Change Order Summary table with columns: Description, Amount. Rows: Total Changes Approved in Previous Months By Owner (\$), Total Approved Changes This Month (\$), Total Contract Change By Change Orders (\$).

1 For major capital projects, FD&C Project Manager to sign. 2 Intermountain's "Monthly Pay Application Checklist" must be submitted by PM with Contractor's Application & Certification for Payment before processing. 3 Contractor has verified the work associated with the "Current Payment Due" and has attached all relevant invoices and backup information with this application & certification for payment.



**CONTINUATION SHEET**  
**Application and Certification for Payment,**  
 Containing Contractor's signed certification is attached.

**Project Name:** Project Name  
**Owner Project #:** Owner Project #  
**Application #:** 1

**Application Date:** 12/1/2018  
**Period To:** 12/31/2018  
**Contractor Invoice #:** 1

A Item No.	B Description of Work	C Original Contract Sum (CM/GC Pre-Construction Fee; Contract Buyouts)	D Total Contract Change By Change Orders	E Current Contract Sum (C + D)	F Work Completed		G Materials Presently Stored This Period (Not in For G)	H Total Completed and Stored Through This Period (F + G + H)	I % (I / E)	J Balance To Finish (E - I)	K This Period Retention (G + H * 5%)	L Total Retention Withheld (I * 5%)	M This Period Retention Released	N Total Retention Released	O Current Payment Due <sup>3</sup> (G + H - L + N)	P	
					From Previous Applications	This Period In Place											
00001	Enter Description of Work	\$ 100.00	\$ -	\$ 100.00	\$ 50.00	\$ 25.00	\$ -	\$ 75.00	75%	\$ 25.00	\$ 1.25	\$ 3.75	\$ -	\$ -	\$ -	23.75	
00002		\$ -	\$ -	\$ -	\$ -	\$ -	\$ -	\$ -		\$ -	\$ -	\$ -	\$ -	\$ -	\$ -	\$ -	
00003		\$ -	\$ -	\$ -	\$ -	\$ -	\$ -	\$ -		\$ -	\$ -	\$ -	\$ -	\$ -	\$ -	\$ -	
00004		\$ -	\$ -	\$ -	\$ -	\$ -	\$ -	\$ -		\$ -	\$ -	\$ -	\$ -	\$ -	\$ -	\$ -	
00005		\$ -	\$ -	\$ -	\$ -	\$ -	\$ -	\$ -		\$ -	\$ -	\$ -	\$ -	\$ -	\$ -	\$ -	
00006		\$ -	\$ -	\$ -	\$ -	\$ -	\$ -	\$ -		\$ -	\$ -	\$ -	\$ -	\$ -	\$ -	\$ -	
00007		\$ -	\$ -	\$ -	\$ -	\$ -	\$ -	\$ -		\$ -	\$ -	\$ -	\$ -	\$ -	\$ -	\$ -	
00008		\$ -	\$ -	\$ -	\$ -	\$ -	\$ -	\$ -		\$ -	\$ -	\$ -	\$ -	\$ -	\$ -	\$ -	
00009		\$ -	\$ -	\$ -	\$ -	\$ -	\$ -	\$ -		\$ -	\$ -	\$ -	\$ -	\$ -	\$ -	\$ -	
00010		\$ -	\$ -	\$ -	\$ -	\$ -	\$ -	\$ -		\$ -	\$ -	\$ -	\$ -	\$ -	\$ -	\$ -	
00011		\$ -	\$ -	\$ -	\$ -	\$ -	\$ -	\$ -		\$ -	\$ -	\$ -	\$ -	\$ -	\$ -	\$ -	
00012		\$ -	\$ -	\$ -	\$ -	\$ -	\$ -	\$ -		\$ -	\$ -	\$ -	\$ -	\$ -	\$ -	\$ -	
00013		\$ -	\$ -	\$ -	\$ -	\$ -	\$ -	\$ -		\$ -	\$ -	\$ -	\$ -	\$ -	\$ -	\$ -	
00014		\$ -	\$ -	\$ -	\$ -	\$ -	\$ -	\$ -		\$ -	\$ -	\$ -	\$ -	\$ -	\$ -	\$ -	
00015		\$ -	\$ -	\$ -	\$ -	\$ -	\$ -	\$ -		\$ -	\$ -	\$ -	\$ -	\$ -	\$ -	\$ -	
00016		\$ -	\$ -	\$ -	\$ -	\$ -	\$ -	\$ -		\$ -	\$ -	\$ -	\$ -	\$ -	\$ -	\$ -	
00017		\$ -	\$ -	\$ -	\$ -	\$ -	\$ -	\$ -		\$ -	\$ -	\$ -	\$ -	\$ -	\$ -	\$ -	
00018		\$ -	\$ -	\$ -	\$ -	\$ -	\$ -	\$ -		\$ -	\$ -	\$ -	\$ -	\$ -	\$ -	\$ -	
00019		\$ -	\$ -	\$ -	\$ -	\$ -	\$ -	\$ -		\$ -	\$ -	\$ -	\$ -	\$ -	\$ -	\$ -	
00020		\$ -	\$ -	\$ -	\$ -	\$ -	\$ -	\$ -		\$ -	\$ -	\$ -	\$ -	\$ -	\$ -	\$ -	
00021		\$ -	\$ -	\$ -	\$ -	\$ -	\$ -	\$ -		\$ -	\$ -	\$ -	\$ -	\$ -	\$ -	\$ -	
00022		\$ -	\$ -	\$ -	\$ -	\$ -	\$ -	\$ -		\$ -	\$ -	\$ -	\$ -	\$ -	\$ -	\$ -	
00023		\$ -	\$ -	\$ -	\$ -	\$ -	\$ -	\$ -		\$ -	\$ -	\$ -	\$ -	\$ -	\$ -	\$ -	
00024		\$ -	\$ -	\$ -	\$ -	\$ -	\$ -	\$ -		\$ -	\$ -	\$ -	\$ -	\$ -	\$ -	\$ -	
00025		\$ -	\$ -	\$ -	\$ -	\$ -	\$ -	\$ -		\$ -	\$ -	\$ -	\$ -	\$ -	\$ -	\$ -	
00026		\$ -	\$ -	\$ -	\$ -	\$ -	\$ -	\$ -		\$ -	\$ -	\$ -	\$ -	\$ -	\$ -	\$ -	
00027		\$ -	\$ -	\$ -	\$ -	\$ -	\$ -	\$ -		\$ -	\$ -	\$ -	\$ -	\$ -	\$ -	\$ -	
00028		\$ -	\$ -	\$ -	\$ -	\$ -	\$ -	\$ -		\$ -	\$ -	\$ -	\$ -	\$ -	\$ -	\$ -	
00029		\$ -	\$ -	\$ -	\$ -	\$ -	\$ -	\$ -		\$ -	\$ -	\$ -	\$ -	\$ -	\$ -	\$ -	
<b>Intermountain Project Grand Totals</b>		\$ 100.00	\$ -	\$ 100.00	\$ 50.00	\$ 25.00	\$ -	\$ 75.00	75%	\$ 25.00	\$ 1.25	\$ 3.75	\$ -	\$ -	\$ -	\$ 23.75	

**Attachment "D"**

**UTAH**

**CONDITIONAL WAIVER AND RELEASE UPON PROGRESS PAYMENT**

TO:	IHC HEALTH SERVICES, INC.	("Owner")
FROM:	<u>ENTER CONTRACTOR NAME</u>	("Contractor")
PROPERTY NAME:	<u>Enter Project Name</u>	("Property")
PROPERTY LOCATION:	<u>Enter Project Address</u>	
CONTRACT DATE:	<u>Enter Date (April 16, 2019)</u>	
INVOICE DATE/NUMBER:		("Invoice")
PAYMENT PERIOD:		
PAYMENT AMOUNT:	\$	("Payment Amount")

Under this Conditional Waiver and Release, Contractor releases Owner and the Property from, and waives, any notice of lien or right under Utah law (see Utah Code Ann., Title 38, Chapter 1a, Pre-construction and Construction Liens, and Utah Code Ann., Title 14, Contractors' Bonds, or Section 63G-6a-1103) related to payment rights the Contractor has on the Property once:

1. Contractor endorses a check in the Payment Amount payable to Contractor or provides valid wire transfer or direct deposit instructions; and
2. The check is paid by the depository institution on which it is drawn or the wired or direct-deposited funds in the Payment Amount are deposited into Contractor's designated account.

This Conditional Waiver and Release applies to the progress payment for the work, materials, equipment, or combination of work, materials, and equipment furnished by Contractor to the Property or to Owner covered by the Invoice. This Conditional Waiver and Release does not apply to any retention withheld; any items, modifications, or changes pending approval; disputed items and claims; or items furnished or invoiced after the Invoice Period.

Contractor warrants that it either has already paid, or will promptly use the Payment Amount received to pay in full all of Contractor's laborers, subcontractors, materialmen, and suppliers for all work, materials, equipment, or combination of work, materials, and equipment under the Invoice. Contractor has not assigned any lien or right to perfect a lien against the Property and has the right, power, and authority to execute this Conditional Waiver and Release.

ENTER CONTRACTOR NAME, a Enter  
Corporation Type

By: \_\_\_\_\_  
Print Name: \_\_\_\_\_  
Title: \_\_\_\_\_

**Attachment “D”**

**UTAH**

**WAIVER AND RELEASE UPON FINAL PAYMENT**

TO:	IHC HEALTH SERVICES, INC.	(“Owner”)
FROM:	<u>ENTER CONTRACTOR NAME</u>	(“Contractor”)
PROPERTY NAME:	<u>Enter Project Name</u>	(“Property”)
PROPERTY LOCATION:	<u>Enter Project Address</u>	
CONTRACT DATE:	<u>Enter Date (April 16, 2019)</u>	
INVOICE DATE/NUMBER:		(“Invoice”)
PAYMENT PERIOD:		
TOTAL PAYMENT AMOUNT:	\$	(“Payment Amount”)

Under tis Waiver and Release, Contractor releases Owner and the Property from, and waives, any notice of lien or right under Utah law (see Utah Code Ann., Title 38, Chapter 1a, Pre-construction and Construction Liens, and Utah Code Ann., Title 14, Contractors' Bonds, or Section 63G-6a-1103) related to payment rights the Contractor has on the Property once:

1. Contractor endorses a check in the Payment Amount payable to Contractor or provides valid wire transfer or direct deposit instructions; and
2. The check is paid by the depository institution on which it is drawn or the wired or direct-deposited funds in the Payment Amount are deposited into Contractor’s designated account.

This Waiver and Release applies to the final payment for the work, materials, equipment, or combination of work, materials, and equipment furnished by Contractor to the Property or to Owner.

Contractor warrants that it either has already paid, or will promptly use the Payment Amount received to pay in full all of Contractor’s laborers, subcontractors, materialmen, and suppliers for all work, materials, equipment, or combination of work, materials, and equipment under the Invoice. Contractor has not assigned any lien or right to perfect a lien against the Property and has the right, power, and authority to execute this Waiver and Release.

ENTER CONTRACTOR NAME, a Enter

Corporation Type

By: \_\_\_\_\_

Print Name: \_\_\_\_\_

Title: \_\_\_\_\_

## UTILITIES SHUTDOWN REQUEST (Utilities & Emergency Egress, Etc.)

<b>Project Name:</b>	Project Name Address Address	<b>Contractor:</b>	Contractor Contact Name Phone Number
<b>Owner:</b>	IHC Health Services, Inc.	<b>Contractor(s)/ Subcontractor(s) Performing Work:</b>	Contractor Contact Name Phone Number
<b>FD&amp;C PM:</b>	PM Name		
<b>Start of Impairment:</b>	Date Time	<b>End of Impairment:</b>	Date Time

### IMPAIRMENT REQUIREMENTS

The Utilities Shutdown Request **MUST** be approved by Facility Management 3 working days (min.) before work begins.

Facility Management **MUST** be notified when work is ready to begin and when work is complete.

Facility Management and Contractor(s) will reactivate system(s) at approved times and **MUST** be notified if impairments need to be extended.

### SECTION 1 – IMPAIRED INFORMATION TO BE COMPLETED BY CONTRACTOR

#### AREA(S) AFFECTED (Building, Floor, Area/Department, Users, Devices, etc.)

Text

#### TYPE OF SHUTDOWN (CHECK ALL THAT APPLY)

<input type="checkbox"/> <b>Electrical</b>	<input type="checkbox"/> Emergency Power* <input type="checkbox"/> Main Switch Gear* <input type="checkbox"/> Individual Panel	<input type="checkbox"/> Single Breaker <input type="checkbox"/> Fire Alarm System* <input type="checkbox"/> _____
<input type="checkbox"/> <b>Plumbing</b>	<input type="checkbox"/> Sewer Stock <input type="checkbox"/> Vent <input type="checkbox"/> Hot Water Domestic	<input type="checkbox"/> Cold Water Domestic <input type="checkbox"/> Steam Line <input type="checkbox"/> _____
<input type="checkbox"/> <b>Sprinkler</b>	<input type="checkbox"/> Riser* <input type="checkbox"/> Individual Heat <input type="checkbox"/> Horizontal Mains/Areas	<input type="checkbox"/> Valves* <input type="checkbox"/> _____
<input type="checkbox"/> <b>Medical Gas</b>	<input type="checkbox"/> Compressed Air <input type="checkbox"/> Oxygen <input type="checkbox"/> Nitrous Oxide	<input type="checkbox"/> Vacuum <input type="checkbox"/> Special Mix Gas <input type="checkbox"/> Zone Valve Boxes <input type="checkbox"/> _____

<input type="checkbox"/> <b>Mechanical</b>	<input type="checkbox"/> Chilled Water	<input type="checkbox"/> Hot Water	<input type="checkbox"/> VAV's
	<input type="checkbox"/> Steam	<input type="checkbox"/> Compressor	<input type="checkbox"/> Electrical Disconnects
	<input type="checkbox"/> Glycol	<input type="checkbox"/> Condenser	<input type="checkbox"/> _____

\* Requires Fire Alarm & Security Coordination

**FACILITY PERMITS**

**\*\*Above Ceiling**

**\*\*Hot Work**

**\*\*Infection Control Risk Control (ICRA)**

**\*\*Other** \_\_\_\_\_

\*\* Completed forms must be attached

**PERCENT OF IMPAIRMENT** (For partial impairment, attach a list showing the area, smoke head, fire suppression system etc. that will be impaired)

*Text*

**REASON FOR IMPAIRMENT**

*Text*

**COMMENTS**

*Text*

**ATTACHMENTS**

1. *3\_Pre-Construction GC Detailed Shutdown Plan\_Template.xlsx*
2. *Facility Site Area Floor Plan*

**SECTION 2 – TO BE COMPLETED BY FACILITY MANAGEMENT**

1. Will fire alarm be taken off line for any amount of time? Yes \_\_\_\_\_ No \_\_\_\_\_  
If Yes, Facility Management must review and sign. \_\_\_\_\_
2. Will this impairment extend more than 4 hours? Yes \_\_\_\_\_ No \_\_\_\_\_  
If Yes, a fire watch must be implemented, Intermountain Healthcare Safety Officer and Insurance Provider must be notified.
3. Department Managers of impaired areas notified:  
Facility Management: \_\_\_\_\_ Date: \_\_\_\_\_  
FD&C Project Manager: \_\_\_\_\_ Date: \_\_\_\_\_



# Above Ceiling Work Permit

\*\*Standards Referenced: NFPA 101 2012; NFPA 30 2012; NFPA 45 2011; NFPA 99 2012

Facility Name:   
Requestor Name:   
Company/Dept:   
Contact Phone:

Permit No.:   
Project No.:   
Work/PO No.:

Start Date:  Start Time:   
End Date:  End Time:

Exact Location of Work:

Description of Work:

Will ANY penetrations be made in walls, roof, floor or ceilings?  Yes  No

Will wiring or data cabling be installed or modified?  Yes  No

### Type of Wiring

- |   |   |
|---|---|
| <input type="checkbox"/> Communication                  | <input type="checkbox"/> HVAC                         |
| <input type="checkbox"/> Door Control                   | <input type="checkbox"/> Security                     |
| <input type="checkbox"/> Low or High Voltage Electrical | <input type="checkbox"/> Telephone                    |
| <input type="checkbox"/> Fiber Optic                    | <input type="checkbox"/> Television                   |
| <input type="checkbox"/> Fire Alarm                     | <input type="checkbox"/> Other - <input type="text"/> |

Will fixtures, appliances, duct work or equipment be installed?  Yes  No

### How will the work be supported?

- |   |  |
|---|--|
| <input type="checkbox"/> Fastened to deck or structure      | <input type="checkbox"/> New cable tray                |
| <input type="checkbox"/> Fastened to wall                   | <input type="checkbox"/> New pipe rack or conduit rack |
| <input type="checkbox"/> Existing cable tray                | <input type="checkbox"/> Other - <input type="text"/>  |
| <input type="checkbox"/> Existing pipe rack or conduit rack |  |

Intermountain Point of Contact:  POC Phone:   
Print Name Clearly

### Site Pre-Inspection

Intermountain Representative:  Requestor:   
Print Name Clearly Print Name Clearly

Notes or Observations (if any):

### Site Post-Inspection

Intermountain Representative:  Requestor:   
Print Name Clearly Print Name Clearly

- No unsealed penetrations observed  All installations properly supported

Notes or Observations (if any):

### Intermountain Review and Approval of Work

Intermountain Representative:  Date:   
Signature

### Why do we have to do this?

- Because more people die of smoke inhalation in fires than die of fires in fires.
- Because 6% of all TJC findings at Intermountain are penetrations in smoke or fire barriers.

**THIS PAGE INTENTIONALLY BLANK**

# Hot Work Permit



Facility Name:

Requestor Name:

Company/Dept:

Contact Phone:

Permit No.:

Project No.:

Start Date:

End Date:

Work / PO No.:

Start Time:

End Time:

Exact Location of Work:

Description of Work:

### Heat Sources

- Gas Torch     Grinder     Arc Welder     Drill     Chemical  
 Other -

Will work require disabling fire detection or suppression systems?  Yes  No

Will systems be disabled longer than 4 hours in any 24 hours?  Yes  No

Will work generate smoke, odors or fumes?  Yes  No

### Establishing The Work Area

- |  |  |
|--|--|
| <input type="checkbox"/> 35' space clear of combustibles           | <input type="checkbox"/> Appropriate fire extinguishers on hand      |
| <input type="checkbox"/> Fire blankets or protective mats in place | <input type="checkbox"/> Confined space permit on hand or not needed |
| <input type="checkbox"/> Space is well-ventilated                  | <input type="checkbox"/> Atmosphere tested non-explosive             |
| <input type="checkbox"/> Signage and barricades in place           | <input type="checkbox"/> Welding shields are in place as needed      |
| <input type="checkbox"/> Safety observer on hand                   | <input type="checkbox"/> Fire watch arranged for                     |
| <input type="checkbox"/> Other precautions: <input type="text"/>   |  |

Intermountain Point of Contact:  POC Phone:

Emergency Phone Number:

### Upon Conclusion of Work

Name of Fire Watch Personnel:  Supervisor:

- Fire watch was kept for 60 minutes after hot work was complete  
 No sign of smoke or fire was detected during fire watch

Notes or Observations (if any):

### Intermountain Review and Approval of Work

Intermountain Point of Contact:  Date:

### Why do we have to do this?

- Because more people die of smoke inhalation in fires than die of fires in fires.
- Because 6% of all TJC findings at Intermountain are penetrations in smoke or fire barriers.

**THIS PAGE INTENTIONALLY BLANK**

## A/E SUPPLEMENTAL INSTRUCTIONS

## ASI # 001

<b>Project Name:</b>	<b>Project Name</b> <b>Address</b> <b>Address</b>	<b>A/E:</b>	<b>A/E</b>
<b>Bid Package:</b>	<b>1.0X</b>	<b>Date:</b>	<b>Date Issued</b>
<b>Owner:</b>	<b>IHC Health Services, Inc.</b>	<b>ASI Page Count:</b>	<b>XX</b>
<b>Intermountain Project #:</b>	<b>Project ID #</b>	<b>ASI Prepared By:</b>	<b>Name</b>
<b>FD&amp;C PM:</b>	<b>PM Name</b>	<b>Contractor:</b>	<b>Contractor</b>
<b>ASI Description:</b>	<b>Description</b>		

### Reason For Change (Required):

- A/E Error  
  A/E Omission  
  A/E Request  
  GC Request  
  Owner/FD&C Request  
  Functional Request  
 Unknown Condition

*The Work shall be executed in accordance with the following supplemental instructions, which interpret the Contract Documents or order minor changes in the Work without change in Construction Costs, Contract Sum and/or Contract Time.*

*If the Contractor believes that a change in Construction Costs, Contract Sum, and/or Contract Time is warranted, the Contractor shall submit written notice in the form of a Proposed Change Order (PCO) substantiating such claim to the A/E. The claim shall be made in accordance with the provisions of the Contract Documents. The Owner's authorization is required prior to proceeding with any Work which will incur additional cost and/or time.*

### DETAILED DESCRIPTION:

Text

### ATTACHMENTS:

Text

**Approved by FD&C<sup>1</sup>:**

\_\_\_\_\_  
(Signature)

\_\_\_\_\_  
(Date)

<sup>1</sup> For major and geographical capital projects, FD&C Project Manager to sign.

# CONSTRUCTION CHANGE DIRECTIVE

## CCD # 001

<b>Project Name:</b>	<b>Project Name</b> <b>Address</b> <b>Address</b>	<b>A/E:</b>	<b>A/E</b>
<b>Bid Package:</b>	<b>1.0X</b>	<b>Date:</b>	<b>Date Issued</b>
<b>Owner:</b>	<b>IHC Health Services, Inc.</b>	<b>CCD Page Count:</b>	<b>XX</b>
<b>Intermountain Project #:</b>	<b>Project ID #</b>	<b>CCD Prepared By:</b>	<b>Name</b>
<b>FD&amp;C PM:</b>	<b>PM Name</b>	<b>Contractor:</b>	<b>Contractor</b>
<b>CCD Subject:</b>	<b>Subject</b>		

**Reason For Change (Required):**

- A/E Error  
  A/E Omission  
  A/E Request  
  GC Request  
  Owner/FD&C Request  
  Functional Request  
 Unknown Condition

**ESTIMATED CHANGE IN CONSTRUCTION COSTS, CONTRACT SUM, OR CONTRACT TIME:**

\$

*In order to expedite the work and avoid or minimize delays in the work which may affect the contract sum and/or contract time, the Contract Documents are hereby amended as described below. Proceed with this work promptly. Submit final costs for work involved and change in Contract Time (if any as a Proposed Change Order), for inclusion in a subsequent Change Order, per the General Conditions.*

*All work shall be in accordance with the terms, stipulations and conditions of the original Contract Documents.*

**DESCRIBE BRIEFLY ANY PROPOSED CHANGES:**

Text

**ATTACHMENTS:**

Text

**Approved by FD&C PM<sup>1</sup>:** \_\_\_\_\_  
(Signature) (Date)

**Approved by System Construction Director<sup>2</sup>:** \_\_\_\_\_  
(Signature) (Date)

**Approved by Executive Director<sup>3</sup>:** \_\_\_\_\_  
(Signature) (Date)

---

<sup>1</sup> For major and geographical capital projects, FD&C Project Manager to sign.

<sup>2</sup> System Construction Director to sign when the charge exceeds \$40,000 for geographical managed projects, or \$200,000 for major capital projects, as outlined in the "Approval Authority Capital Expenditures Policy".

<sup>3</sup> Executive Director, Design & Construction to sign when the charge exceeds \$200,000 as outlined in the "Construction Change Order Procedure".

**THIS PAGE INTENTIONALLY BLANK**







# PROPOSED CHANGE ORDER

## PCO # 001

<b>Project Name:</b>	<b>Project Name</b> <b>Address</b> <b>Address</b>	<b>Contractor:</b>	<b>Contractor</b>
<b>Bid Package:</b>	<b>1.0X</b>	<b>PCO Issue Date:</b>	<b>Date Issued</b>
<b>Owner:</b>	<b>IHC Health Services, Inc.</b>	<b>PCO Page Count:</b>	<b>XX</b>
<b>Intermountain Project #:</b>	<b>Project ID #</b>	<b>PCO Prepared By:</b>	<b>Name</b>
<b>FD&amp;C PM:</b>	<b>PM Name</b>	<b>A/E:</b>	<b>A/E</b>

\*Once this document is executed the Contractor is authorized to proceed with the work described below and to include this PCO in a Change Order for A/E and Owner approval.

<b>PCO Description:</b>	<b>Description</b>
<b>Reference:</b>	<b>Reference ASI, RFI, PR, CCD change document this PCO is in response to.</b>

### Reason For Change (Required):

- \*A/E Error  
  \*A/E Omission  
  A/E Request  
  GC Request  
  Owner/FD&C Request  
  \*\*Functional Request  
 Unknown Condition

\*If A/E Error or A/E Omission is checked, the Contractor is to provide pricing delta (bid cost vs. C.O. cost) to determine A/E responsibility.

\*\*If Functional Request is checked, the Facility (or responsible department) and FD&C PM are to determine the Facility's cost responsibility, including design fees and the Facility representative is to initial the PCO or provide email acknowledgement of financial commitment and attach to PCO. FD&C PM to coordinate with Capital Finance on facility reimbursement once PCO is signed.

\*\*\*Contract Time request must be in compliance with the Agreement, General Conditions, and be included in a subsequent Change Order.

### PCO Details:

\*A/E is responsible for \$ \_\_\_\_\_ . Agreed to if PCO is signed.  
 \*\*Facility is responsible for \$ \_\_\_\_\_ . Agreed to if PCO is signed.

Item	Subcontractor	Description	Amount
-	-	Enter Description	\$
		PCO Subtotal	\$
		Subcontractor Default Insurance (SDI) (Insert %)	\$
		General Liability Insurance Fee (Insert %)	\$
		Contractors (CM/GC) Fee (Insert %)	\$
		Total Cost of this PCO Request	\$
		***Contract Time will be increased (decreased) by	0 Days



**PROPOSAL REQUEST****PR # 001**

<b>Project Name:</b>	Project Name Address Address	<b>A/E:</b>	A/E
<b>Bid Package:</b>	1.0X	<b>Date:</b>	Date Issued
<b>Owner:</b>	IHC Health Services, Inc.	<b>PR Page Count:</b>	XX
<b>Intermountain Project #:</b>	Project ID #	<b>PR Prepared By:</b>	Name
<b>FD&amp;C PM:</b>	PM Name	<b>Contractor:</b>	Contractor
<b>PR Description:</b>	Description		

**Reason For Change (Required):**

- A/E Error    A/E Omission    A/E Request    GC Request    Owner/FD&C Request    Functional Request
- Unknown Condition

Please submit a fully itemized list of Construction Costs, with supporting documentation, for any changes in the Construction Costs, Contract Sum, and/or Contract Time incidental to the proposed modifications to the Contract Documents.

**THIS IS NOT A CHANGE ORDER, A CONSTRUCTION CHANGE DIRECTIVE OR A NOTICE TO PROCEED WITH THE WORK DESCRIBED IN THE PROPOSED MODIFICATIONS.**

**DESCRIPTION:**

Text

**ATTACHMENTS:**

Text

**Requested by:** \_\_\_\_\_  
(Signature) (Printed Name and Title) (Date)

**Approved by FD&C PM<sup>1</sup>:** \_\_\_\_\_  
(Signature) (Date)

<sup>1</sup> For major and geographical capital projects, FD&C Project Manager to sign.

**THIS PAGE INTENTIONALLY BLANK**

# REQUEST FOR INFORMATION

## RFI # 001

<b>Project Name:</b>	<b>Project Name</b> <b>Address</b> <b>Address</b>	<b>Contractor:</b>	<b>Contractor</b>
<b>Bid Package:</b>	<b>1.0X</b>	<b>Date:</b>	<b>Date Issued</b>
<b>Owner:</b>	<b>IHC Health Services, Inc.</b>	<b>RFI Page Count:</b>	<b>XX</b>
<b>Intermountain Project #:</b>	<b>Project ID #</b>	<b>RFI Prepared By:</b>	<b>Name</b>
<b>FD&amp;C PM:</b>	<b>PM Name</b>	<b>A/E:</b>	<b>A/E</b>
<b>RFI Description:</b>	<b>Description</b>		
<b>Cross Reference:</b>	<b>ASI #, Drawing Info, etc.</b>	<b>RFI Response Date Requested:</b>	<b>Date</b>

**Contractor Attestation (Required checkbox):** *The undersigned Contractor has reviewed the Contract Documents and is unable to locate this requested information within the Contract Documents. This RFI requests information, direction, or clarification for this specific item.*

**Contractor Signature:** *Signature* **Date:** *Date*

### QUESTION:

Text

### RESPONSE:

Text

**A/E Response By:** **Name** **Date:** **Date**

**A/E PM Acknowledgement:** **Name** **Date:** **Date**

# Contractor Orientation

Intermountain Healthcare Facilities Management

*This orientation is to be read to all workers by the Facility Manager or designee, and a copy is to be given to each worker on the job site.*

## Safety on the Job Site

### Your Safety

Unsafe acts will not be tolerated on the job site. We want you to be as healthy and whole when you go home, as you were when you arrived.

Appropriate PPE will be worn at all times while working on the job site. Ladders and other equipment will be used properly.

Always use the proper lock-out/tag-out (LOTO) procedures and equipment to ensure that you and others are protected from hazardous energy while working. Be aware that energized systems in healthcare facilities can be complex, and your work may affect others in remote areas of the facility. Coordinate any LOTO activity with the Facility Manager and other affected trades.

### The Safety of Others

Nothing you do should put others in danger or harm them in any way. Be thoughtful and deliberate about safety.

## Your Behavior on the Job Site

### How You Should Act

You should come to work with a clean body in clean clothes. You should come to work sober. Attempting to work while under the influence of any drugs or alcohol – even if they are prescribed – can be dangerous to you and others, and is cause for immediate removal from the job site.

Be considerate of others. Remember that others may take offense at things you do, even when you mean no harm. Avoid doing or saying things that may bother or upset others.

No music, no smoking, no cursing, no shouting, no leering, no fighting, no racially or culturally insensitive comments, no suggestive or offensive comments, no propositions, and no soliciting are permitted while you are on the job site.

### Phones, Cameras, and Other Communication or Recording Devices

You should not carry on personal communication or phone conversations while on the job site.

You must NEVER photograph, or video or audio record ANYTHING or ANYONE on Intermountain Healthcare property. This will not be tolerated, and in some cases this may violate the law. If work needs to be photographed, have your supervisor or the facilities team on site take the pictures.

On this job site, the person who authorizes photography or recording is: \_\_\_\_\_.



## Where You Should Be on the Property

### Parking

Park only in the location identified by the Facility Manager in your orientation. Parking personal vehicles in any other location may result in their removal.

On this job site, the parking location is: \_\_\_\_\_.

### Smoking

Smoking is not allowed on any Intermountain property. If you need to smoke, vape, or use tobacco in other ways, you must leave the property and return when you're done.

Drugs are never allowed.

### Break Time

Take breaks only in areas identified by the Facility Manager in your orientation. During breaks do not engage in loud conversation or use offensive language.

On this job site, the break location is: \_\_\_\_\_.

### Meals

The Facility Manager will tell you in your orientation if you are permitted to use the facility cafeteria and dining room during your meal time. Take meals only in areas identified by the Facility Manager in your orientation.

Never take breaks in public areas meant for patients and their guests.

On this job site, the meal location is: \_\_\_\_\_.

On this job site, the break location is: \_\_\_\_\_.

## When You Should Be on the Property

When you are working, or on the property for work you should not arrive earlier than is necessary for you to assemble your tools and equipment for the day. Arriving very early and 'hanging around' is not permitted. Your supervisor will tell you what time you should arrive at work.

When you are done with the work day, and your tools and equipment are cleaned and put away, and your job site is clean, you should leave the property directly. Staying on the job site after work is not permitted.

Of course, if you are a patient, or are visiting one of our patients, you are always welcome in the public areas of the facility. Do not visit the job site unless you are here for work.

We ask you that while you are here you remember that you may be seen by others as representing your company or ours, and to please comport yourself accordingly.

## How a Healthcare Facility May Be Different from Other Jobs Sites

### People

The people who come to our hospitals and other facilities come because they feel sick, hurt, scared, or sad. They don't come to see us when everything is going fine. They want to feel safe and comfortable and confident that everything will be better soon.

Many of them are sensitive to noise, dust, fumes, odors, and vibrations. Please do everything you can to control these irritants.

The procedures we do in our facilities frequently require quiet and stillness. Please be sensitive to this and be ready to accommodate requests to stop work briefly or move to a different area of the facility to continue working.

### Building Systems

The structure of our hospitals and other facilities is intended to actively work to protect our staff, patients, and visitors in the event of an emergency. This means that you must be very careful about how your work impacts other systems and parts of the building. Some of the rules are strange, but all are important.

Certain walls are intended to stop smoke or fire from spreading because when our buildings catch fire we cannot leave. We continue to care for our patients, perform surgeries, help birth babies, and provide emergency medical care. When working around or through these walls – “rated assemblies” – it is critical that you do so properly.

A pre-inspection by a member of the facility's maintenance team of the area you'll be working in is required so that you can understand where rated assemblies are, and how you must treat them. This also gives you an opportunity to identify existing conditions for which you may not be responsible.

A post-inspection by a member of the facility's maintenance team of the work you've done is required so that you can demonstrate that you've complied with all requirements for maintaining the integrity of our protective rated assemblies.

On this job site, the contact for fire stopping materials is: \_\_\_\_\_.

Along with rated assemblies, our facilities have very sensitive fire and smoke detection systems, as well as automatic sprinkler systems. If your activities will cause dust or vibration or impact, be aware and mitigate any adverse effect you may have on these systems.

On this job site, the contact for fire alarm systems is: \_\_\_\_\_.

If your work interrupts or disables any portion of the building's life safety systems, including fire alarm, fire suppression, and emergency egress, you may be required to implement interim life safety measures.

On this job site, the contact for interim life safety is: \_\_\_\_\_.

Much of our air is exhausted to the outside. If you are working around exhaust fans, you must know what areas the exhaust is coming from. Some exhausts are laden with radioactive elements. Some carry infectious diseases and other germs. Your supervisor will tell you about these areas.

On this job site, the hazardous exhaust areas are: \_\_\_\_\_.

Many of our patients depend on clean and fresh outside air to be provided to them. Smoking on roofs or around air intakes is strictly forbidden for this reason. If you must operate equipment on roofs or around air intakes, be certain to coordinate your work with the Facility Manager.

On this job site, the sensitive air intakes are: \_\_\_\_\_.

Much of our equipment may start without notice. Take care to avoid being harmed by unexpected starts, or unexpected discharges of steam, hot water, or chemicals. Unless you are authorized to be working around this equipment you should stay out of these spaces.

All work above the ceiling requires an Above Ceiling Work Permit, and all hot work requires a Hot Work Permit.

On this job site, the contact for Above Ceiling Work Permits is: \_\_\_\_\_.

On this job site, the contact for Hot Work Permits is: \_\_\_\_\_.

### Infection Control

Because many of our patients are ill, there is a chance that you will be exposed to germs. There is also a chance that you will expose our patients to germs you've brought from outside the hospital. We do our best to keep our physical environment clean and to control all infectious matter.

You can protect yourself by ensuring that your vaccinations are current, and by only going in places you are authorized to go. Wash or sanitize your hands frequently – especially after using the restroom and before eating. Never eat food anywhere except where you are told to have meal breaks. The Plumber's Rule No. 3 applies to everyone in healthcare: Don't bite your fingernails!

Your work may require an Infection Control Risk Assessment. The Facility Manager will help you determine when that is, and will help you through the process. This process helps identify the best ways to keep you and our patients safe from infections and other impediments to healing. Once the assessment is done, be certain to abide by all of its conditions.

On this job site, the infection control contact is: \_\_\_\_\_.

### A Clean Job Site

Throughout the work day, you will be responsible to maintain a reasonably clean job site. This makes it a safer place for you to work. It makes it a safer place for others to work, as well.

At the end of each work day, you will be responsible to leave all materials in an orderly state, remove all waste, scrap, and debris from the site, and leave the area broom clean. All potential hazards will be secured and made as safe as possible.

All construction waste and debris must be disposed of properly. Never use toilets or floor drains for this purpose. Cover all carts while moving debris through the facility, and use tacky mats to control dust tracking over floors.

## Our Expectation of Workmanship

It doesn't matter if you're a ventilation mechanic, an electrician, a painter, or a plumber. It doesn't matter if you're installing carpet, or ceiling tiles, or kitchen equipment, or cabinetry. Every piece of our facilities is in place to support the lifesaving and healing work we do.

The hard reality is that someone's life will literally depend on the quality of the workmanship you put into the jobs you do in Intermountain Healthcare facilities.

And it's another hard reality that someone you care for may very likely come to the facilities you helped build. Please do the kind of job you'd trust your loved one's life to.

**THIS PAGE INTENTIONALLY BLANK**



## **CONSTRUCTION SAFETY REQUIREMENTS**

- I. Outside Contractors and Intermountain Construction Employees performing construction activities on occupied Intermountain Healthcare property shall meet the following requirements. Stand-alone, new construction sites are not covered by these requirements. Outside Contractors will meet additional qualifications through the Supply Chain Organization Supplier Credentialing Procedure.
  - a. No work will be performed in any Intermountain Facility without prior approval and coordination with the accountable Facility Engineering Manager or Director.
  - b. Each outside contractor will have a Safety Program that complies with 29 CFR 1926 Subpart C. The Safety Program will be in writing.
  - c. Any chemical brought onto Intermountain Property must meet the following requirements:
    - i. Approved by the facility's Chemical Safety Officer,
    - ii. Accompanied by a current material safety data sheet,
    - iii. Stored in accordance with the chemical manufacturer's safety requirements in the appropriate labeled container.
    - iv. Where the chemical quantity is restricted for Healthcare Occupancies by NFPA 30 or other standards, it is the contractor's responsibility to provide for off-site storage.
    - v. The Contractor is responsible to comply with Intermountain's Hazardous Materials policy.
    - vi. The Contractor is responsible for the removal of all chemicals from Intermountain Property and for proper disposal in accordance with applicable laws and regulations.
  - d. No work will be performed without the completion of an Interim Life Safety and Infection Control Risk Assessment. These risk assessments will cover each phase of the construction project.
  - e. In existing facilities, an Asbestos inspection and any necessary abatement will be conducted prior to any renovation or remodel per the Hazmat policy.
  - f. Where work will cause noise or vibration, an assessment will be made following facility procedures to mitigate potential hazards to patients.
  - g. Above the Ceiling Permits
    - i. The Contractor will follow each facility's procedure for obtaining an above the ceiling work permit.
    - ii. No work will be performed prior to obtaining this permit.
  - h. Hot Work Permits
    - i. The Contractor will obtain a Hot Work Permit from Facilities Engineering prior to performing any hot work.
    - ii. The Contractor will provide a continuous and qualified fire watch for the duration and location specified by the Facility Engineering Director.
  - i. Confined Space Permits
    - i. The contractor will coordinate with the Intermountain Facility Engineering Director to assure that all requirements are met and a permit is completed prior to entering a permit required confined space.

- j. Control of Airborne Contaminants
  - i. The contractor will control all airborne dusts, mists, fumes, and vapors such that there is no exposure to Intermountain employees, patients, or visitors. This includes the generation of contaminants outside the building.
  - ii. If necessary, work will be conducted after hours to minimize potential exposures to staff, patients, and members of the public.
- k. Personal Protective Equipment.
  - i. PPE for head, eye, face, hand, foot, and respiratory protection is the responsibility of the contractor, and will be provided and worn as necessary for the exposure, except as follows:
    - 1. Hard Hats and Safety Glasses are required to be worn at all times when in the construction area. Hard hats may be removed when working in areas where the suspended ceiling grid has been completely installed.
  - ii. Fall Protection is the responsibility of the contractors and shall meet all 29 CFR 1926 requirements of the applicable Subparts.

**RESPONSIBILITY MATRIX**

Updated February 13, 2023

The following list identifies the majority of the items that are to be included in the capital project build-out. All Owner items need to be coordinated with A/E (Design Team), Contractor, and Owner (Facility Design & Construction and Supply Chain Facility Equipment Planners). For OFOI or OFCI items, Contractor is required to track equipment on construction schedule and to notify Owner of required delivery times taking into account for equipment lead times.

ITEM	OWNER/VENDOR	NOTES	ADDITIONAL NOTES		
			Data	Power	Backlog
<b>OFOI - (Owner Furnished / Owner Installed)</b>					
<b>(Coordinate location of items with Owner and track within construction schedule)</b>					
Art	Owner / Owner (Alpine Art)	All artwork to be coordinated with Dan Kohler. Provide power and backing to required artwork.			
Audio/Video (A/V)	Owner / Owner	Intermountain SCO will source & supply the A/V system including specialized cabling (e.g. HDMI, etc). Refer to CFCI section for Contractor requirements. A/E to identify locations on drawings, coordinate with Owner. Contractor to provide infrastructure, back boxes, conduits, pathways and cabling (from wall side back).	Yes	Yes	
Brochure Racks	Owner / Owner	Contractor to provide proper backing.			Yes
Cash (Manual) Drawer	Owner / Owner	Identify locations and coordinate with point-of-sale equipment vendor.			Yes
Chart Racks	Owner / Owner (Midwest)	Contractor to provide proper backing.			Yes
Clinical Garbage Cans (Clinical, Office, PT, Etc.)	Owner / Owner				
Computers, Printers, Scanners, Keyboards, Mice, etc.	Owner / Owner	In-ceiling & wall mounts, conduits and boxes mounted by Contractor. Computers to be All-in-One, typ. in IMG exam rooms.	Yes	Yes	Yes
Copiers, fax	Owner / Owner	A/E to locate where copy/fax/printer is not visual clutter.	Yes	Yes	
Cup Dispensers	Owner / Owner				
Emergency Evacuation Medical Sled (Med Sled)	Owner / Owner	A/E to coordinate location with Owner.			
Exam Tables	Owner / Owner			Yes	
Infant/Pediatric Security System	Owner / Owner (Totguard)	A/E to identify locations on drawings. This system is to be coordinated with Owner, Women's and Children's Operations, Clinical Programs and Security.	Yes	Yes	
IV Hangar	Owner / Owner	A/E to identify locations on drawings, coordinate with Owner. Backing to be coordinated, if required.			
Keyboard Trays	Owner / Owner				
Magnetic Marker Boards, Cork Boards, Huddle Boards, Idea Tracking Boards, etc.	Owner / Owner (Midwest)	A/E to coordinate location with Owner.			Yes
Moveable Metal Shelving	Owner / Owner				
Nurse Notification Call (NNC) System & Devices (Hospital Campus)*	Owner / Owner (Hillrom)	Hospital local facility team to work with Supply Chain Facility Equipment Planning team to contract directly with Nurse Notification Call (NNC) system vendor (Hillrom) for devices, equipment, monitors, etc. A/E to coordinate with Owner and Hillrom for all NNC infrastructure required to support the device locations and types designated by Hillrom on their site specific drawings. Hillrom site specific drawings to be coordinated and included in the A/E Contract Documents. Contractor to provide all infrastructure including conduits, back boxes, cabling (e.g. home-runs to RCB, RCB to device, device to device, etc.), etc. for all NNC devices (e.g. RCB, GSR-10, room devices, etc.). The cabling for the NNC system will be coordinated and installed by the Contractor/Subcontractor (i.e. low voltage sub). Contractor to coordinate with Hillrom.  *Where an existing non-Intermountain standard NNC system exists (e.g., Rauland), Clinical Engineering must be engaged to determine if this existing system will continue or be replaced with the Intermountain standard NNC system. Please also coordinate with CTIS and Facility Equipment Planners. When an existing NNC system is determined to continue, this NNC system will fall under the CFCI section, where the A/E will design the system and the Contractor will provide/furnish and install the system.	Yes; see CFCI	Yes; see CFCI	
PACS	Owner / Owner				
Patient Monitoring System & Devices (Hospital Campus)	Owner / Owner	Hospital local facilities to work with Supply Chain Facility Equipment Planning team to contract directly with Patient Monitoring vendors for devices, equipment, monitors, etc. (from wall side out). A/E to identify locations on drawings, coordinate with Owner. Contractor to provide all infrastructure including conduits, back boxes, and home-run cabling from Patient Monitoring devices to TEC/TDR rooms that connect to Intermountain's network (Intermountain Siemon certified installer low voltage subcontractor to install). The Patient Monitoring system device to device cabling is by Vendor.	Yes	Yes	
Radiology Equipment	Owner / Owner (See subject matter expert list)	A/E responsible to coordinate final site equipment drawings into Construction Documents from Owner's Vendor.	Yes	Yes	
Receptionist Desk	Owner / Owner (Midwest & Steelcase)				
Recliners / Draw Chairs	Owner / Owner				
Sharps Disposal Container	Owner / Owner (Stericycle)	A/E to identify locations on drawings, coordinate with Owner. Backing to be coordinated, if required.			
Signage - Exterior	Owner / Owner (KB Signs, Trademark, YESCO)	Provide power and data to required exterior signage. Provide circuits for above ceiling signs. Coordinate thru-wall conduit sleeves with weather barrier. A/E to coordinate traffic signage and Contractor to install. Intermountain Logo Signs - (2) 20A Circuits - May vary. InstaCare and other Signs - (1) 20 A Circuits - May vary.	Yes	Yes	Yes
Signage - Interior (including Code Signage)	Owner / Owner (Intermountain Sign Shop, Scribbley, Hightech)	Provide power to required signage. Contractor to track in schedule and notify Owner for when Code Required signage is required to be installed.			



Staff Assist Notification Call System & Devices (Medical Group Clinics on hospital campuses to match NNC system)*	Owner / Owner (Hillrom)	Hospital local facility/IMG Ops team to work with Supply Chain Facility Equipment Planning team to contract directly with Staff Assist Notification Call system vendor (Hillrom) for devices, equipment, monitors, etc. (from wall side out). Staff Assist Notification system to be coordinated with Hospital Campus NNC system, as applicable, Medical Group Strategic Planner, and IMG Operations Officer. A/E to coordinate with Owner and Hillrom for all Staff Assist Notification Call system infrastructure required to support the device locations and types designated by Hillrom on their site specific drawings. Hillrom site specific drawings to be coordinated and included in the A/E Contract Documents. Contractor to provide all infrastructure including conduits, back boxes, cabling (e.g. home-runs to RCB, RCB to device, device to device, etc.), etc. for all NNC and Staff Assist Notification Call devices (e.g. RCB, GSR-10, etc.). The cabling for the NNC and Staff Assist Notification Call system will be coordinated and installed by the Contractor/Subcontractor (i.e. low voltage sub). Contractor to coordinate with Hillrom.  *Where an existing non-Intermountain standard NNC system exists (e.g., Rauland), Clinical Engineering must be engaged to determine if this existing system will continue or be replaced with the Intermountain standard NNC system. Please also coordinate with CTIS and Facility Equipment Planners. When an existing NNC system is determined to continue, this NNC system will fall under the CFCI section, where the A/E will design the system and the Contractor will provide/furnish and install the system.	Yes; see CFCI	Yes; see CFCI	
Staff Assist Notification Call System & Devices (Stand-alone Medical Group Clinics)*	Owner / Owner (Hillrom)	IMG Ops team to work with Supply Chain Facility Equipment Planning team to contract directly with Staff Assist Notification Call system vendor (Hillrom) for devices, equipment, monitors, etc. (from wall side out). Staff Assist Notification Call system to be coordinated with Medical Group Strategic Planner and Operations Officer. A/E to coordinate with Owner and Hillrom for all Staff Assist Notification Call system infrastructure required to support the device locations and types designated by Hillrom on their site specific drawings. Hillrom site specific drawings to be coordinated and included in the A/E Contract Documents. Contractor to provide all infrastructure including conduits, back boxes, cabling (e.g. home-runs to RCB, RCB to device, device to device, etc.), etc. for all Staff Assist Notification Call devices (e.g. RCB, GSR-10, etc.). The cabling for the Staff Assist Notification Call system will be coordinated and installed by the Contractor/Subcontractor (i.e. low voltage sub). Contractor to coordinate with Hillrom.  *Where an existing non-Intermountain standard NNC system exists (e.g., Rauland), Clinical Engineering must be engaged to determine if this existing system will continue or be replaced with the Intermountain standard NNC system. Please also coordinate with CTIS and Facility Equipment Planners. When an existing NNC system is determined to continue, this NNC system will fall under the CFCI section, where the A/E will design the system and the Contractor will provide/furnish and install the system.	Yes; see CFCI	Yes; see CFCI	
Supply Area Panels	Owner / Owner	Contractor to provide proper backing, coordinate with Owner.			Yes
Systems Furniture (including demountable partitions)	Owner / Owner (Midwest & Steelcase)	Coordinate modesty panels with elec. outlets. Sit/Stand desks to have modesty panel on front. Attention to be given to cord management. A/E to coordinate data and power with Midwest.	Yes	Yes	
Televisions, Digital Projectors, similar devices, etc.	Owner / Owner	These items to be provided by Owner, but A/E to coordinate locations and infrastructure. Contractor to refer to OFCI section.	Yes	Yes	Yes
<b>OFCI - (Owner Furnished / Contractor Installed) (Coordinate location of items with Owner and track within construction schedule)</b>					
Alertus - Mass Notification System (Public Areas)	Owner (Alertus) / Contractor	A/E to identify locations on drawings, coordinate with Owner.	Yes	Yes	Backing
Apron Hooks/Rack (Heavy Duty in Radiology)	Owner / Contractor	A/E to identify locations on drawings, coordinate with Owner.			Yes
Automated External Defibrillator (AED)	Owner / Contractor	A/E to identify locations on drawings, coordinate with Owner, A/E to coordinate recess, semi-recessed, or surface mount options with Owner.			Yes
Bio Safety Cabinet	Owner / Contractor	A/E to locate equipment on drawings and coordinate all connections. Contractor to track on construction schedule and coordinate final connections when equipment has been installed.		Yes	
Boom and Injector Ceiling Mounting Plates (Equipment, Lighting, Anesthesia, Injection, etc.)	Owner / Contractor	A/E to coordinate with Owner and Owner's selected equipment Vendor; A/E to identify boom locations on drawings, coordinate with Owner; A/E to coordinate the design of the boom support structure into drawings. Final site specific equipment drawings from Vendor to be coordinated with Construction Documents. Contractor to coordinate with Owner and install boom support structure and boom mounting plates. Contractor to coordinate with Owner for ordering and install of boom mounting plates.	Yes	Yes	Yes
Building Alarms / Medication Refrigerator Alarm / Pharmacy Alarm System	Owner / Contractor	A/E to identify locations and infrastructure on drawings, coordinate with Owner. Contractor to provide conduit and infrastructure into accessible ceiling for access from equipment and/or devices. Local Facility to contract with alarm company for alarm, wire, and monitoring.		Yes	
Chain Hoist Industrial Lift	Owner / Contractor	A/E to identify locations on drawings, coordinate with Owner.		Yes	Yes
Clinical Clocks	Owner / Contractor	A/E to identify locations on drawings, coordinate with Owner. Contractor to coordinate with Owner for ordering and install coordination.		Yes	Yes
Clinical Storage Cabinet (Flammable Items)	Owner / Contractor	A/E to identify locations on drawings, coordinate with Owner.			
Cubicle Curtains & Tracks	Owner (Medline) / Contractor	A/E to identify locations on drawings, coordinate with Owner. Contractor to coordinate with Owner for ordering and install coordination.			
Diagnostic Board including Wall Mount Replacable Tips (Otoscope / Ophthalmoscope)	Owner / Contractor	A/E to identify locations on drawings, coordinate with Owner.		Yes	Yes
Diaper Changing Station	Owner / Contractor	A/E to identify locations on drawings, coordinate with Owner.			Yes
Digital Projector Mounts, TV Mounts, & Computer Mounts (Ergotron Brackets/Mounts, etc.)	Owner / Contractor	A/E to identify locations on drawings, coordinate with Owner. Contractor to coordinate with Owner for ordering and install coordination. In-ceiling & wall mounts, conduits and boxes provide and installed by Contractor A/E to coordinate A/V requirements. Contractor to pull required A/V cabling.	Yes	Yes	Yes
Distributed Antenna System (DAS) including Public Safety	Owner (DAS vendor selected and managed by Intermountain CTIS/Telecom) / Contractor	A/E to locate infrastructure on drawings to simplify the DAS install. Contractor to track on construction schedule and coordinate DAS install with Owner's Vendor.			
Exercise Rack Wall Rack	Owner / Contractor	A/E to identify locations on drawings, coordinate with Owner.			Yes
Face Mask Dispenser (Wall Mount)	Owner / Contractor	A/E to identify locations on drawings, coordinate with Owner.			Yes
Grossing Workstation	Owner / Contractor	A/E to locate equipment on drawings and coordinate all connections. Contractor to track on construction schedule and coordinate final connections when equipment has been installed.	Yes	Yes	Yes
Hand Sanitizer Dispensers (Avagard)	Owner / Contractor	A/E to identify locations on drawings, coordinate with Owner.			

Hoods (Chemical Soak Station, Ranges, Horizontal Laminar Flow, and similar Hoods)	Owner / Contractor	A/E to identify locations on drawings, including infrastructure requirements, coordinate with Owner.		Yes	Yes	
Ice Machine Dispenser (Undercounter, Countertop, etc.)	Owner / Contractor	A/E to identify locations on drawings, including infrastructure requirements, coordinate with Owner.		Yes		
iCentra Tracking Boards	Owner / Contractor	A/E to identify locations on drawings, coordinate with Owner.	Yes	Yes	Yes	
IV Track	Owner / Contractor	A/E to identify locations on drawings, coordinate with Owner. Backing to be coordinated, if required.			Yes	
Kitchen Range (Electric)	Owner / Contractor	A/E to identify locations on drawings, including infrastructure requirements, coordinate with Owner.		Yes		
Laundry Dryer, Washer (single, stacked, disinfectant)	Owner / Contractor	A/E to identify locations on drawings, including infrastructure requirements, coordinate with Owner.		Yes		
Medication Return Bin	Owner / Contractor	A/E to identify locations on drawings, coordinate with Owner. This is a pass-thru unit for medication return accessed from public corridor into a secured locked room.			Yes	
OR Clocks	Owner / Contractor	A/E to identify locations on drawings, coordinate with Owner. Contractor to coordinate with Owner for ordering and install coordination.	Yes	Yes	Yes	
Paper Towel Dispensers	Owner / Contractor	A/E to identify locations on drawings, coordinate with Owner.				
Pass-thru Cleanroom Chamber	Owner / Contractor	A/E to identify locations on drawings, including infrastructure requirements, coordinate with Owner. Perimeter of each pass-thru unit must be sealed to maintain space pressurization.		Yes	Yes	
Patient Lifts	Owner (Liko, subsidiary of Hillrom) / Contractor	A/E to identify locations on drawings, coordinate with Owner. A/E to design required support structure for Contractor to install for necessary Liko patient lift connections (e.g. pendant / rails / etc). Contractor to coordinate shop drawings and installation requirements prior with Liko. Connect to equipment branch if provided.		Yes		
Personal Protection Dispensers (gloves, gowns, masks, shoe covers, etc.)	Owner / Contractor	A/E to identify locations on drawings, coordinate with Owner.			Yes	
Pharmaceutical Pass-thru Refrigerator	Owner / Contractor	A/E to identify locations on drawings, including infrastructure requirements, coordinate with Owner. Perimeter of each pass-thru unit must be sealed to maintain space pressurization.		Yes		
Pharmacy Dispensing Water Treatment System	Owner / Contractor	A/E to identify locations on drawings, including infrastructure requirements, coordinate with Owner.		Yes	Yes	
Procedure Lights	Owner / Contractor	A/E to coordinate with Owner and Owner's selected equipment Vendor; A/E to identify locations on drawings, coordinate with Owner; A/E to coordinate the design of the procedure light support structure into drawings. Contractor to provide and install procedure light support structure.		Yes	Yes	
Radiation Protection Calculations and Certification	Owner / Contractor	A/E to coordinate with Owner in the design phase for coordinating with Medical Physicists Consultants or others, when required. Contractor to coordinate prior to Gyp. Bd. install.			Yes	
Sanitary Napkin Dispensers/Receptacles	Owner / Contractor	A/E to identify locations on drawings, coordinate with Owner.				
Scrub Brush Dispenser (Wall Mount)	Owner / Contractor	A/E to identify locations on drawings, coordinate with Owner.			Yes	
Scrub Sinks & Carriers	Owner / Contractor	A/E to identify locations on drawings, coordinate with Owner. Contractor to coordinate with Owner for ordering and for install coordination.			Yes	
Shower Curtains & Rods	Owner (Medline) / Contractor	A/E to identify locations on drawings, coordinate with Owner. Contractor to coordinate with Owner for ordering and install coordination.				
Soap Dispensers	Owner / Contractor	A/E to identify locations on drawings, coordinate with Owner.				
Stadiometers, Recessed Scales	Owner / Contractor	A/E to identify locations on drawings, coordinate with Owner; coordinate power and floor recesses.		Yes		
Time Clocks	Owner / Contractor	Conduit and boxes by Contractor, Coordinate location with Owner.	Yes	Yes		
Tissue Dispenser (Wall Mount)	Owner / Contractor	A/E to identify locations on drawings, coordinate with Owner.			Yes	
Toilet Paper Dispensers	Owner / Contractor	A/E to identify locations on drawings, coordinate with Owner.				
Undercounter Dishwasher	Owner / Contractor	A/E to locate equipment on drawings and coordinate all connections. Contractor to track on construction schedule and coordinate final connections when equipment has been installed.		Yes		
UPS (MRI, Data Room, CPU, or other similar equipment)	Owner / Contractor	A/E to identify equipment locations on drawings, coordinate with Owner.	Yes	Yes	Yes	
Wall Mount Basket for Cuff	Owner / Contractor	A/E to identify locations on drawings, coordinate with Owner.			Yes	
Wall Mount Bracket for Clinical Monitor (sizes vary)	Owner / Contractor	A/E to identify locations on drawings, coordinate with Owner.		Yes	Yes	
Wall Mount Bracket for Disinfectant Wipes	Owner / Contractor	A/E to identify locations on drawings, coordinate with Owner.			Yes	
Wall Mount Bracket for Emesis Bags	Owner / Contractor	A/E to identify locations on drawings, coordinate with Owner.			Yes	
Wall Mount Bracket for Eyewear/Eyeshield Dispenser	Owner / Contractor	A/E to identify locations on drawings, coordinate with Owner.			Yes	
Wall Mount Bracket for Patient Transfer Device, Patient Evacuation Device (Med Sled)	Owner / Contractor	A/E to identify locations on drawings, coordinate with Owner.			Yes	
Wall Mount Bracket for Suction Canister	Owner / Contractor	A/E to identify locations on drawings, coordinate with Owner.			Yes	
Wall Mount for Area Radiation Monitor	Owner / Contractor	A/E to identify locations on drawings, coordinate with Owner.		Yes	Yes	
Wall Mount for Mops, Brooms, etc.	Owner / Contractor	A/E to identify locations on drawings, coordinate with Owner.			Yes	
Wall Mount for Phlebotomy Station (Infant)	Owner / Contractor	A/E to identify locations on drawings, coordinate with Owner.			Yes	
Wall Mount Hair Dryer	Owner / Contractor	A/E to identify locations on drawings, coordinate with Owner.		Yes	Yes	
Wall Mounted Chemical Spill Kit	Owner / Contractor	A/E to identify locations on drawings, coordinate with Owner.			Yes	
Wall Mounted Modular Storage Shelving	Owner / Contractor	A/E to identify locations on drawings, coordinate with Owner.			Yes	
Wall Mounted Shelving	Owner / Contractor	A/E to identify locations on drawings, coordinate with Owner.			Yes	
Wall Mounted Thermometer (Temporal Artery, Digital, etc.)	Owner / Contractor	A/E to identify locations on drawings, coordinate with Owner.			Yes	
Zip Line Exerciser Kit	Owner / Contractor	A/E to identify locations on drawings, coordinate with Owner.			Yes	
<b>CFCI - (Contractor Furnished / Contractor Installed)</b>			<b>(Coordinate location of items with A/E Design Team and track within construction schedule)</b>	<b>Data</b>	<b>Power</b>	<b>Backing</b>
Access Control, Card Readers (Lenel)	Contractor / Contractor (AlphaCorp/Convergint)	A/E to identify locations on drawings, coordinate with Owner.	Yes	Yes		
Audio/Video (A/V)	Contractor / Contractor	Intermountain SCO will source & supply the A/V system including specialized cabling (e.g. HDMI, etc). A/E to identify locations on drawings, coordinate with Owner. Contractor to provide infrastructure, back boxes, conduits, pathways and misc. cabling (from wall side back).	Yes	Yes		
Blinds/Shades (manual and powered)	Contractor / Contractor	A/E to identify locations on drawings, coordinate with Owner.		Yes		
Coat Hooks (Rest rooms>Showers, Exam rooms, Offices/Workstations only)	Contractor / Contractor	A/E to identify locations on drawings.			Yes	
Communication Boards (e.g. Patient Rooms)	Contractor / Contractor	A/E to identify locations on drawings, coordinate with Owner. If boards are electronic, then data and power should also be provided.			Yes	
Communication Cabling	Contractor / Contractor	A/E to identify locations on drawings, coordinate with Owner. See Intermountain Design Guidelines and Construction Standards for additional information.				
Emergency Phones, Kiosks - Exterior	Contractor / Contractor	A/E to identify locations on drawings, coordinate with Owner. Conduit and boxes by Contractor.	Yes	Yes	Yes	
Emergency Shower Station / Eye Wash Station	Contractor / Contractor	A/E to identify locations on drawings, coordinate with Owner. These shall meet ANSI and Owner requirements.			Yes	
Fire Extinguishers	Contractor / Contractor	A/E to identify types and locations on drawings, coordinate with Owner. 10 lbs. minimum - refer to Intermountain Design Guidelines & Construction Standards.			Yes	
Grab Bars (Rest rooms, Radiology, Exam rooms, etc.)	Contractor / Contractor	A/E to identify locations on drawings.			Yes	
Intrusion Detection	Contractor / Contractor	A/E to identify locations on drawings, coordinate with Owner.				
Med Gas Certification	Contractor / Contractor	Contractor to coordinate Vendor with Owner				

Mirrors (Rest rooms, Exams, Radiology, Rehab, etc.)	Contractor / Contractor	A/E to identify locations on drawings, coordinate with Owner.			Yes
Nurse Notification Call (NNC) System - Low Voltage Cabling (Hospital Campus)*	Contractor / Contractor (Hillrom)	A/E to coordinate with Owner and Hillrom for all NNC infrastructure required to support the device locations and types designated by Hillrom on their site specific drawings. Hillrom site specific drawings to be coordinated and included in the A/E Contract Documents. Contractor to provide all infrastructure including conduits, back boxes, cabling (e.g. home-runs to RCB, RCB to device, device to device, etc.), etc. for all NNC devices (e.g. RCB, GSR-10, etc.). The cabling for the NNC system will be coordinated and installed by the Contractor/Subcontractor (i.e. low voltage sub). Contractor to coordinate with Hillrom.  *Where an existing non-Intermountain standard NNC system exists (e.g., Rauland), Clinical Engineering must be engaged to determine if this existing system will continue or be replaced with the Intermountain standard NNC system. Please also coordinate with CTIS and Facility Equipment Planners. When an existing NNC system is determined to continue, this NNC system will fall under the CFCI section, where the A/E will design the system and the Contractor will provide/furnish and install the system.	Yes	Yes	
Patient Monitoring System & Devices (Hospital Campus)	Contractor / Contractor	A/E to identify locations on drawings, coordinate with Owner. Contractor to provide all infrastructure including conduits, back boxes, and home-run cabling from Patient Monitoring devices to TEC/TDR rooms that connect to Intermountain's network (Intermountain Siemon certified installer low voltage subcontractor to install). The Patient Monitoring system device to device cabling is by Vendor.	Yes	Yes	Yes
Plumbing Shrouds	Contractor / Contractor				
Pneumatic Tube Systems	Contractor / Contractor (SwissLog, Atreo Group, or other approved)	A/E to identify locations on drawings, coordinate with Owner. If SwissLog, verify pricing is per Intalere (Amerinet) Contract Agreement. Design assistance fees are included in this agreement.	Yes	Yes	
Radiation Protection (Lead) Installation - (ex. Cath Lab, CT Scanner, X-Ray)	Contractor / Contractor	A/E to identify locations on drawings and coordinate with Owner's Vendor on the required shielding thicknesses.			Yes
Radiofrequency/Magnetic (RF) Shielding Installation - MRI	Contractor / Contractor	A/E to coordinate with Owner in the design phase and coordinate appropriate shielding.			Yes
Security Cameras, Video Surveillance	Contractor / Contractor (AlphaCorp/Convergint)	A/E to identify locations on drawings, coordinate with Owner.	Yes		
Staff Assist Notification Call System - Low Voltage Cabling (Medical Group Clinics on hospital campuses to match NNC system)*	Contractor / Contractor (Hillrom)	A/E to coordinate with Owner and Hillrom for all Staff Assist Notification Call system infrastructure required to support the device locations and types designated by Hillrom on their site specific drawings. Hillrom site specific drawings to be coordinated and included in the A/E Contract Documents. Contractor to provide all infrastructure including conduits, back boxes, cabling (e.g. home-runs to RCB, RCB to device, device to device, etc.), etc. for all NNC and Staff Assist Notification Call devices (e.g. RCB, GSR-10, etc.). The cabling for the NNC and Staff Assist Notification Call system will be coordinated and installed by the Contractor/Subcontractor (i.e. low voltage sub). Contractor to coordinate with Hillrom.  *Where an existing non-Intermountain standard NNC system exists (e.g., Rauland), Clinical Engineering must be engaged to determine if this existing system will continue or be replaced with the Intermountain standard NNC system. Please also coordinate with CTIS and Facility Equipment Planners. When an existing NNC system is determined to continue, this NNC system will fall under the CFCI section, where the A/E will design the system and the Contractor will provide/furnish and install the system.	Yes	Yes	
Staff Assist Notification Call System - Low Voltage Cabling (Stand-alone Medical Group Clinics)*	Contractor / Contractor (Hillrom)	A/E to coordinate with Owner and Hillrom for all Staff Assist Notification Call system infrastructure required to support the device locations and types designated by Hillrom on their site specific drawings. Hillrom site specific drawings to be coordinated and included in the A/E Contract Documents. Contractor to provide all infrastructure including conduits, back boxes, cabling (e.g. home-runs to RCB, RCB to device, device to device, etc.), etc. for all Staff Assist Notification Call devices (e.g. RCB, GSR-10, etc.). The cabling for the Staff Assist Notification Call system will be coordinated and installed by the Contractor/Subcontractor (i.e. low voltage sub). Contractor to coordinate with Hillrom.  *Where an existing non-Intermountain standard NNC system exists (e.g., Rauland), Clinical Engineering must be engaged to determine if this existing system will continue or be replaced with the Intermountain standard NNC system. Please also coordinate with CTIS and Facility Equipment Planners. When an existing NNC system is determined to continue, this NNC system will fall under the CFCI section, where the A/E will design the system and the Contractor will provide/furnish and install the system.	Yes	Yes	
Support Bracing/Structure for Radiology and similar equipment	Contractor / Contractor	A/E to coordinate with Owner and Owner's selected Radiology equipment Vendor; A/E to coordinate the design of the support bracing/structure into drawings. Final site specific equipment drawings from Vendor to be coordinated with Construction Documents. Contractor to coordinate with Owner for install of support structure.	Yes	Yes	Yes
TV System Distribution	Contractor / Contractor	A/E to identify locations on drawings, coordinate with Owner.			
Voice/Data Cabling (all horizontal cabling)	Contractor / Contractor (Cache Valley Elec., IES Commercial, Data Tech Professionals, Hunt Electric, and others listed in Intermountain Div. 27)	Refer to Division 27 in the Intermountain Design Guidelines and Construction Standards. Coordinate with Owner/User on connections, pairs of fiber/copper, conduits, inner-ducts, etc.	Yes		
Wall Protection (Incl. Bumper and Corner Guards)	Contractor / Contractor	A/E to identify locations on drawings, coordinate with Owner. Backing should be included where heavy use/damage may occur.			

**THIS PAGE INTENTIONALLY BLANK**

## TAX EXEMPTION CERTIFICATE

### PART 1 - GENERAL

#### 1.1 SUMMARY

- A. Construction materials purchased by or on behalf of **Intermountain Healthcare** *may be* exempt from Utah sales and use taxes. Tax Exempt **Form TC-721** must be used by vendors when purchasing construction materials for **Intermountain Healthcare** projects. A copy of Form TC-721, with the Owner's pertinent tax information, follows this cover page.



Utah State Tax Commission • 210 N 1950 W • Salt Lake City, UT 84137

**Exemption Certificate**  
(Sales, Use, Tourism and Motor Vehicle Rental Tax)

**TC-721**  
Rev. 11/18

Name of business or institution claiming exemption (purchaser) IHC Health Services, Inc.		Telephone number 801.442.2000	
Street address 36 South State Street, Suite 2200	City Salt Lake City	State UT	ZIP Code 84111
Authorized signature 	Name (please print) Brian Deppe	Title Corporate Tax Director	
Name of Seller or Supplier:		Date	
Sales Tax License Number: 11990296-013-STC		Required for all exemptions marked with an asterisk (*)	

The signer of this certificate MUST check the box showing the basis for which the exemption is being claimed.

**DO NOT SEND THIS CERTIFICATE TO THE TAX COMMISSION**  
Keep it with your records in case of an audit.

For purchases by government, Native American tribes and public schools, use form TC-721G.

**Resale or Re-lease**

I certify I am a dealer in tangible personal property or services that are for resale or re-lease. If I use or consume any tangible personal property or services I purchase tax free for resale, or if my sales are of food, beverages, dairy products and similar confections dispensed from vending machines (see Rule R865-19S-74), I will report and pay sales tax directly to the Tax Commission on my next sales and use tax return.

**Religious or Charitable Institution**

I certify the tangible personal property or services purchased will be used or consumed for essential religious or charitable purposes. **This exemption can only be used on purchases totaling \$1,000 or more, unless the sale is pursuant to a contract between the seller and purchaser.**

**Construction Materials Purchased for Religious and Charitable Organizations**

I certify the construction materials are purchased on behalf of a religious or charitable organization and that they will be installed or converted into real property owned by the religious or charitable organization.

Name of religious or charitable organization: \_\_\_\_\_

Name of project: \_\_\_\_\_

**Fuels, Gas, Electricity**

I certify all natural gas, electricity, coal, coke, and other fuel purchased will be used for industrial use only and not for residential or commercial purposes.

**Machinery and Equipment and Normal Operating Repair or Replacement Parts Used in a Manufacturing Facility, Mining Activity, Web Search Portal or Medical Laboratory**

I certify the machinery and equipment, normal operating repair or replacement parts, or materials (except office equipment or office supplies) are for use in a Utah manufacturing facility described in SIC Codes 2000-3999 or a NAICS code within NAICS Sector 31-33; in a qualifying scrap recycling operation; in a co-generation facility placed in service on or after May 1, 2006; in the operation of a Web search portal by a new or expanding business described in NAICS Code 518112; in a medical laboratory described in NAICS Code 621511; or in a business described in NAICS 212, Mining (except Oil and Gas), or NAICS 213113, Support Activities for Coal Mining, NAICS 213114, Support Activities for Metal Mining, or NAICS 213115, Support Activities for Nonmetallic Minerals (except Fuels) Mining. For a definition of exempt mining equipment, see Utah Code §59-12-104(14).

**Machinery and Equipment and Normal Operating Repair or Replacement Parts Used in an Electronic Payment Service**

I certify the machinery and equipment and normal operating repair or replacement parts have an economic life of three years or more and are for use in the operation of an electronic payment service described in NAICS Code 522320.

**Machinery or Equipment Used by Payers of Admissions or User Fees**

I certify that: (1) the machinery or equipment has an economic life of three or more years and will be used by payers of admissions or user fees (Utah Code §59-12-103(1)(f)); (2) the buyer is in the amusement, gambling or recreation industry (NAICS Subsector 713); and (3) at least 51 percent of the buyer's sales revenue for the previous calendar quarter came from admissions or user fees.

**Refinery Machinery, Equipment and Normal Repair or Replacement Parts**

I certify the machinery, equipment, normal operating repair parts, catalysts, chemicals, reagents, solutions or supplies are for the use of a refiner who owns, leases, controls or supervises a refinery (see Utah Code §63M-4-701) located in Utah.

**Pollution Control Facility**

I certify our company has been granted a "Certification of Pollution Control Facilities" as provided for by Utah Code §§19-12-101 - 19-12-305 by either the Air Quality Board or the Water Quality Board. I further certify each item of tangible personal property purchased under this exemption is qualifying.

**Municipal Energy**

I certify the natural gas or electricity purchased: is for resale; is prohibited from taxation by federal law, the U.S. Constitution, or the Utah Constitution; is for use in compounding or producing taxable energy; is subject to tax under the Motor and Special Fuel Tax Act; is used for a purpose other than as a fuel; is used by an entity exempted by municipal ordinance; or is for use outside a municipality imposing a municipal energy sales and use tax. The normal sales tax exemptions under Utah Code §59-12-104 do not apply to the Municipal Energy Sales and Use Tax.

**Short-term Lodging Consumables**

I certify the tangible personal property is consumable items purchased by a lodging provider as described in Utah Code §59-12-103(1)(i).

**Direct Mail**

I certify I will report and pay the sales tax for direct mail purchases on my next Utah *Sales and Use Tax Return*.

**Commercial Airlines**

I certify the food and beverages purchased are by a commercial airline for in-flight consumption; or, any parts or equipment purchased are for use in aircraft operated by common carriers in interstate or foreign commerce.

**Commercials, Films, Audio and Video Tapes**

I certify that purchases of commercials, films, prerecorded video tapes, prerecorded audio program tapes or records are for sale or distribution to motion picture exhibitors, or commercial television or radio broadcasters. If I subsequently resell items to any other customer, or use or consume any of these items, I will report any tax liability directly to the Tax Commission.

**Alternative Energy**

I certify the tangible personal property meets the requirements of Utah Code §59-12-104 and is leased or purchased by or for an alternative energy electricity production facility, a waste energy production facility, or a facility that produces fuel from alternative energy.

**Locomotive Fuel**

I certify this fuel will be used by a railroad in a locomotive engine.

**Research and Development of Alternative Energy Technology**

I certify the tangible personal property purchased will be used in research and development of alternative energy technology.

**Life Science Research and Development Facility**

I certify that: (1) the machinery, equipment and normal operating repair or replacement parts purchased have an economic life of three or more years for use in performing qualified research in Utah; or (2) construction materials purchased are for use in the construction of a new or expanding life science research and development facility in Utah.

**Mailing Lists**

I certify the printed mailing lists or electronic databases are used to send printed material that is delivered by U.S. mail or other delivery service to a mass audience where the cost of the printed material is not billed directly to the recipients.

**Semiconductor Fabricating, Processing or Research and Development Material**

I certify the fabricating, processing, or research and development materials purchased are for use in research or development, manufacturing, or fabricating of semiconductors.

**Telecommunications Equipment, Machinery or Software**

I certify these purchases or leases of equipment, machinery, or software, by or on behalf of a telephone service provider, have a useful economic life of one or more years and will be used to enable or facilitate telecommunications; to provide 911 service; to maintain or repair telecommunications equipment; to switch or route telecommunications service; or for sending, receiving, or transporting telecommunications service.

**Ski Resort**

I certify the snow-making equipment, ski slope grooming equipment or passenger rope-ways purchased are to be paid directly with funds from the ski resort noted on the front of this form.

**Aircraft Maintenance, Repair and Overhaul Provider**

I certify these sales are to or by an aircraft maintenance, repair and overhaul provider for the use in the maintenance, repair, overhaul or refurbishment in Utah of a fixed-wing, turbine-powered aircraft that is registered or licensed in a state or country outside Utah.

**Leasebacks**

I certify the tangible personal property leased satisfies the following conditions: (1) the property is part of a sale-leaseback transaction; (2) sales or use tax was paid on the initial purchase of the property; and, (3) the leased property will be capitalized and the lease payments will be accounted for as payments made under a financing arrangement.

**Film, Television, Radio**

I certify that purchases, leases or rentals of machinery or equipment will be used by a motion picture or video production company for the production of media for commercial distribution.

**Prosthetic Devices**

I certify the prosthetic device(s) is prescribed by a licensed physician for human use to replace a missing body part, to prevent or correct a physical deformity, or support a weak body part. This is also exempt if purchased by a hospital or medical facility. (Sales of corrective eyeglasses and contact lenses are taxable.)

**Out-of-State Construction Materials**

I certify this tangible personal property, of which I am taking possession in Utah, will be taken out-of-state and will become part of real property located in a state that does not have sales tax, is taxed at a lower rate, or does not allow credit for tax paid to Utah. I will report the tax on my next Utah return at the lower of the Utah rate where the tangible personal property was purchased or the rate of the location where the tangible personal property is converted to real property in the other state if the other state allows a credit for tax paid to Utah.

**Agricultural Producer**

I certify the items purchased will be used primarily and directly in a commercial farming operation and qualify for the Utah sales and use tax exemption. **This exemption does not apply to vehicles required to be registered.**

**Tourism/Motor Vehicle Rental**

I certify the motor vehicle being leased or rented will be temporarily used to replace a motor vehicle that is being repaired pursuant to a repair or an insurance agreement; the lease will exceed 30 days; the motor vehicle being leased or rented is registered for a gross laden weight of 12,001 pounds or more; or, the motor vehicle is being rented or leased as a personal household goods moving van. This exemption applies only to the tourism tax (up to 7 percent) and the short-term motor vehicle rental tax (Transportation Corridor Funding – 2.5 percent) – not to the state, local, transit, zoo, hospital, highways, county option or resort sales tax.

**Textbooks for Higher Education**

I certify that textbooks purchased are required for a higher education course, for which I am enrolled at an institution of higher education, and qualify for this exemption. An institution of higher education means: the University of Utah, Utah State University, Utah State University Eastern, Weber State University, Southern Utah University, Snow College, Dixie State University, Utah Valley University, Salt Lake Community College, or the Utah System of Technical Colleges.

\* Purchaser must provide sales tax license number in the header on page 1.

**NOTE TO PURCHASER:** You must notify the seller of cancellation, modification, or limitation of the exemption you have claimed.

Questions? Email [taxmaster@utah.gov](mailto:taxmaster@utah.gov), or call 801-297-2200 or 1-800-662-4335.

**THIS PAGE INTENTIONALLY BLANK**



**BID FORM**

**TO:** **IHC Health Services, Inc.** (Intermountain Healthcare)  
Facility Design and Construction (FD&C)  
36 South State Street, 16th Floor  
Salt Lake City, Utah 84111-1486

**Attention:** Project Coordinator  
Email: [xxxx@imail.org](mailto:xxxx@imail.org)

**PROJECT:** **Intermountain Healthcare Project Name**  
Project Address  
Project Address

**NAME OF BIDDER:** \_\_\_\_\_

**BIDDER ADDRESS:** \_\_\_\_\_

**DATE:** \_\_\_\_\_

The undersigned, in compliance with your Invitation To Bid, having examined the Drawings and Specifications (Contract Documents) and related documents and the site of the proposed work and being familiar with all of the conditions surrounding the construction of the proposed project, including the availability of labor, hereby propose to furnish all labor, materials, services, equipment and appliances required in connection with or incidental to the construction of the above named project in strict conformance with the following specification and drawings:

Instructions to Bidders, General Conditions, Supplemental General Conditions, Specification Divisions as shown and all applicable addenda and Drawings as listed on the drawing cover sheets as prepared by NJRA Architects

I/We certify, by signing this BID FORM, that I/We have a working relationship with the proposed subcontractors and that Bids we're not solicited from, and/or the received Contract Documents were not listed in any public Plan Rooms for distribution to subcontractors broadly.

**BASE BID – for the Project Name for Intermountain Healthcare:**

For Work of the contract listed above and shown on the Drawings and described in the Project Manual, I/We agree to perform for the sum of:

\_\_\_\_\_ Dollars (\$) \_\_\_\_\_  
(In the case of discrepancy, written amount shall govern)

**ALTERNATES:**

**Alternate No. 1: Sample**

ADD/DELETE \_\_\_\_\_ Dollars (\$) \_\_\_\_\_  
(In the case of discrepancy, written amount shall govern)  
Required additional calendar days: \_\_\_\_\_

**Alternate No. 2: Sample**

ADD/DELETE \_\_\_\_\_ Dollars (\$) \_\_\_\_\_  
(In the case of discrepancy, written amount shall govern)

Required additional calendar days: \_\_\_\_\_

**Alternate No. 3: Sample**

ADD/DELETE \_\_\_\_\_ Dollars (\$ \_\_\_\_\_)

(In the case of discrepancy, written amount shall govern)

Required additional calendar days: \_\_\_\_\_

**CONTRACTOR'S PROPOSED CONSTRUCTION TIME PERIOD:**

This Bid requires a construction time in **calendar days** from the date of authorization of \_\_\_\_\_ calendar days. The anticipated date of Substantial Completion is thus \_\_\_\_\_, 20\_\_\_\_.

The above Bid includes \_\_\_\_\_ winter weather delay days.

**ADDENDA:**

I/We acknowledge receipt of the following addenda for the above noted project: \_\_\_/\_\_\_/\_\_\_/\_\_\_/\_\_\_

**SCHEDULE OF VALUES:**

I/We have attached with this Bid Form our Schedule of Values (Section 014373) which reflects the above Base Bid. We submit this for Owner review of subcontractors that are being proposed for this Project.

**TYPE OF ORGANIZATION:**

(Corporation, Partnership, Individual, etc.) \_\_\_\_\_

SEAL (If a Corporation)

Respectfully Submitted,

\_\_\_\_\_  
Name of Bidder

\_\_\_\_\_  
Authorized Signature

## GENERAL CONDITIONS

1. General Provisions
2. Intermountain
3. A/E
4. Contractor
5. Subcontractors
6. Protection of Persons and Property
7. Modifications, Request for Information, Proposed Change Orders, and Claims Process
8. Payments and Completion
9. Tests and Inspections, Substantial and Final Completion, Uncovering, Correction of Work, and Guaranty Period
10. Insurance and Bonds
11. Miscellaneous Provisions
12. Termination or Suspension of the Contract

### 1. GENERAL PROVISIONS.

#### 1.1 Basic Definitions.

**“Adverse Weather”**: Weather conditions that are seasonably abnormal and could not reasonably have been anticipated.

**“A/E”**: Generally, the licensed architect (or architecture firm) or engineer (or engineering firm) for the Project. For Contracts where the design professional is an interior designer, landscape subconsultant or other design professional, “A/E” will be deemed to refer to that design professional. If the type of design professional is not subject to professional licensure requirements, the professional must meet the prevailing standards in the State in which the Project is located for the applicable practice. When Intermountain elects not to engage an A/E for a Project, Intermountain will be considered the A/E for the Project.

**“A/E’s Agreement”**: Unless the context requires otherwise, the agreement executed by A/E and Intermountain for the Project.

**“Addenda”**: Written or graphic instruments issued before the opening of Bids, which clarify, correct or change the bidding documents or the Contract Documents.

**“ASI”**: A Supplemental Instruction issued by A/E to Contractor, which may result in clarifications or minor changes in the Work, but which does not affect the Contract Time or the Contract Sum.

**“Bid”**: The offer of the bidder submitted on the prescribed form setting forth the proposed stipulated sum for the Work to be performed.

**“Bonds”**: The bid bond, payment and performance bonds, and other instruments of security.

**“Change Order”**: A written instrument signed by Intermountain and Contractor, stating their agreement for changes to the Contract as specified on the required Intermountain change order form.

**“Claim”**: A dispute, demand, assertion or other matter arising in connection with the Contract or the Project submitted by Contractor or a Subcontractor at any tier in accordance with these General Conditions. A requested amendment, requested Change Order, or a Construction Change Directive (CCD) is not a Claim unless agreement cannot be reached in accordance with the procedures in these General Conditions.

**“Construction Change Directive” or “CCD”**: A written order signed by Intermountain, directing a change in the Work, and stating a proposed basis for adjustment, if any, in the Contract Sum or Contract Time, or both. Intermountain may by Construction Change Directive, without invalidating the Contract, order changes in the Work within the general scope of the Contract consisting of additions, deletions or other revisions; even if it may impact the Contract Sum and Contract Time.

**“Contract”**: The Contract Documents form the Contract for Construction.

**“Contract Documents”**: The documents identified as such in the Contractor’s Agreement.

**“Contract Sum”**: The amount stated in the Contractor’s Agreement payable by Intermountain to Contractor for performance of the Work under the Contract Documents.

**“Contract Time”**: The Contract Time means the period of time for Contractor’s Substantial Completion of the Work to be established as set forth in the Contractor’s Agreement.

**“Contractor”**: The person or entity identified as the “Contractor” in the Contractor’s Agreement.

**“Contractor’s Agreement”**: The “Contractor’s Agreement” means the Construction Manager/General Contractor Agreement or the General Contractor Agreement for a Stipulated Sum, as applicable, executed by Contractor and Intermountain for the Project.

**“Contractor’s Direct Costs”**: Actual costs incurred by the Contractor for labor, materials, equipment, insurance, bonds, Subcontractors and on-site supervision. They do not include labor costs for project managers or other off-site administration.

**“Day” or “Days”**: Calendar day unless otherwise specified.

**“Defective”**: Work that does not conform to the Contract Documents or does not meet the requirements of any inspection, referenced standard, code, test or approval referred to in the Contract Documents or by applicable law, or has been damaged.

**“Director”**: Intermountain’s Executive Director of Design & Construction unless the context requires otherwise. Director may include a designee selected by the Director for a specific function.

**“Drawings”**: The construction drawings identified in the Contractor’s Agreement.

**“Intermountain”**: IHC Health Services, Inc., operating through its Department of Facility Design and Construction. Unless the context requires otherwise, Intermountain is the “Owner” as that term is commonly referred to in the construction industry.

**“Intermountain Representative” or “Owner’s Representative”**: The person identified as such in the Contract Documents.

**“Inspection” (or any derivative)**: A review of the Project, including but not limited to a visual review of the Work to ascertain if the Work is in accordance with the Contract Documents, including all applicable building codes and construction standards.

**“Invitation to Bid”**: Intermountain’s solicitation or request to a contractor to provide a Bid.

**“Modification”**: (1) Change Order, (2) Construction Change Directive, or (3) ASI.

**“Notice to Proceed”**: A document prepared by Intermountain authorizing Contractor to commence Work on the Project. It is deemed issued upon delivery to Contractor or upon being sent by Intermountain to the address for Contractor’s specified in the Bid or Proposal.

**“Partial Use”**: Placing a portion of the Work in service for the purpose for which it is intended (or a related purpose) before reaching Substantial Completion for all the Work. Partial Use does not constitute “substantial completion.”

**“Product Data”**: Illustrations, standard schedules, performance charts, instructions, brochures, diagrams and other information furnished by Contractor to illustrate materials or equipment for some portion of the Work.

**“Project”**: Generally identified and defined in the Contractor’s Agreement and Contract Documents. It includes all of the Work to be performed under the Contract Documents.

**“Project Manual” (for construction)**: The volume of assembled Specifications for the Work, which may include the bidding/proposal requirements, sample forms, and General or Supplementary Conditions of the Contract.

**“Proposal”**: A/E’s or Contractor’s response to Intermountain’s Request for Proposal.

**“Proposal Request”** or **“PR”**: A written request submitted to Contractor for a proposal to resolve an issue as part of the Change Order or Contract Modification process.

**“Proposed Change Order”** or **“PCO”**: An informal request by Contractor to Intermountain Representative to commence the Contract Modification Process. It will not be considered a “Claim.” The PCO may be related to any potential or actual delay, disruption, unforeseen condition or materials or any other matter for which Contractor intends to seek additional monies or time.

**“Record Drawings”**: Record drawings, compiled by the A/E based upon redline “as-built” construction drawings and/or other information provided by Contractor, for each completed phase or portion of the Project for which a certificate of occupancy is issued, or for the final, completed Project (as applicable), in both AutoCAD (.dwg) and REVIT (.rvt) format (or other format as reasonable requested by Intermountain).

**“Request for Information”** or **“RFI”**: A request by Contractor to A/E for information, direction or clarification regarding the Contract Documents, plans or specifications.

**“Request for Proposal”** or **“RFP”**: Intermountain’s solicitation for Contractor Proposals.

**“Sales Tax”** and/or **“Use Tax”**: Unless the context requires otherwise, the sales tax or use tax collected or to be collected by any Federal or State Tax Commission as well as by any special district, local government or political subdivision.

**“Samples”**: Physical examples, which illustrate materials, equipment or workmanship and establish standards by which the Work will be judged.

**“Shop Drawings”**: Drawings, diagrams, schedules and other data specially prepared for the Work by Contractor or a Subcontractor, Sub-subcontractor, manufacturer, supplier or distributor to illustrate some portion of the Work.

**“Specifications”**: The portion of the Contract Documents consisting of the written requirements for materials, equipment, construction systems, standards, installation and workmanship for the Work, and for performance of related systems and services.

**“Subcontractor”**: Any person or entity that has a direct contract with Contractor, including any trade contractor or specialty contractor, and/or with any other Subcontractor at any tier to provide labor or materials for the Work.

**“Subcontractor’s Direct Costs”**: Actual costs incurred by a Subcontractor for labor, materials, equipment, insurance, bonds, lower-tier Subcontractors and supervision.

**“Substantial Completion”**: Completion of the Work or designated portion thereof in accordance with the Contract Documents to a point sufficient to allow Intermountain to occupy and use the Work for its intended purposes, including without limitation all systems shall be fully functional and operate as designed, and the A/E’s certification that Contractor has achieved Substantial Completion of the Work. The date of Substantial Completion is the date certified as such by the A/E in accordance with the Contract Documents.

**“Work”**: All labor, materials, tools, equipment, construction and services required by the Contract Documents.

## **1.2 Correlation and Intent of Contract Documents.**

- 1.2.1 The intent of the Contract Documents is to require Contractor to provide all labor, materials, equipment, construction, and services necessary for the proper execution and completion of the Work. The Contract Documents are complementary and what is required by any one will be as binding as if required by all. Contractor will perform the Work in accordance with the requirements expressly set forth in or reasonably inferable from the Contract Documents.

- 1.2.2 The organization of the Contract Documents is not intended to control Contractor in dividing the Work among Subcontractors or to establish the extent of the Work to be performed by any trade.
- 1.2.3 Words used in the Contract Documents that have well known technical or trade meanings are used therein in accordance with such recognized meanings.
- 1.2.4 In the interest of brevity, the Contract Documents may omit modifying words such as "all" and "any" and articles such as "the" and "an," but the fact that a modifier or an article is absent from one statement and appears in another is not intended to affect the interpretation of either statement.

**1.3 Ownership and Use of Contract Documents.** The Drawings, the Project Manual, and copies thereof are the property of Intermountain. Contractor will not use these documents on any other project. Contractor may retain one copy of the Drawings and the Project Manual as a contract record set and will return or destroy all remaining copies following final completion of the Work.

**1.4 Public Statements Regarding Project.** Contractor will not make any statements or provide any information to the media about the Project without the prior written consent of Intermountain. If Contractor receives any requests for information from media, Contractor will refer such requests to Intermountain.

**1.5 Ownership and Use of Renderings and Photographs.** Renderings representing the Work are the property of Intermountain. All photographs of the Work, whether taken during performance of the Work or at completion, are the property of Intermountain. Intermountain reserves all rights including copyrights to renderings and photographs of the Work. No renderings or photographs will be used or distributed without written consent of Intermountain.

**1.6 Confidentiality / Property Rights.**

- 1.6.1 All Drawings, Specifications and other documents prepared by A/E are and will remain the property of Intermountain, and Intermountain will retain all common law, statutory and other reserved rights with respect thereto. These documents were prepared and are intended for use as an integrated set for the Project which is the subject of the Contractor's Agreement and constitute works made for hire. Contractor will not modify or use Contract Documents on any other project without the prior written consent of Intermountain. Intermountain may withhold its consent in its absolute discretion. Any non-permissive use or modification, by Contractor, Contractor's Subcontractors at any tier or anyone for whose acts Contractor is liable, will be at Contractor's sole risk. Contractor will hold harmless and indemnify Intermountain from and against any and all claims, actions, suits, costs, damages, loss, expenses and attorney fees arising out of such non-permissive use or modification by Contractor. Contractor and Subcontractors are granted a limited license to use and reproduce applicable portions of the Drawings, Specifications and other documents prepared by A/E or Intermountain appropriate to and for use in the execution of their Work under the Contract Documents. All copies made under this license will bear the statutory copyright notice, if any, shown on the Drawings, Specifications and other documents prepared by A/E or Intermountain. Submittals or distributions necessary to meet official regulatory requirements or for other purposes relating to completion of the Project are not to be construed as a publication in derogation of Intermountain's copyright or other reserved rights.
- 1.6.2 In addition, Contractor will ensure that Contractor, Subcontractors, and the employees, agents and representatives of Contractor and its Subcontractors maintain in strict confidence, and will use and disclose only as authorized by Intermountain all Confidential Information of Intermountain that Contractor receives in connection with the performance of the Contract. Notwithstanding the foregoing, Contractor may use and disclose any information to the extent required by an order of any court or authority having jurisdiction, but only after it has notified Intermountain and Intermountain has had an opportunity to obtain reasonable protection for such information in connection with such disclosure. For purposes of the Contract, "Confidential Information" means:
- 1.6.3 The name or address of any affiliate, customer or contractor of Intermountain or any information concerning the transactions of any such person with Intermountain;

- 1.6.4 Any information relating to contracts, agreements, business plans, budgets or other financial information of Intermountain to the extent such information has not been made available to the public by Intermountain; and
- 1.6.5 Any other information that is marked or noted as confidential by Intermountain at the time of its disclosure.

**1.7 Comply with Intellectual Property Rights of Others.** Contractor represents and warrants that no Work (with its means, methods, goods, and services attendant thereto), provided to Intermountain will infringe or violate any right of any third party and that Intermountain may use and exploit such Work, means, methods, goods, and services without liability or obligation to any person or entity (specifically and without limitation, such Work, means, methods, goods, and services will not violate rights under any patent, copyright, trademark, or other intellectual property right or application for the same).

## **2. INTERMOUNTAIN.**

### **2.1 Information and Services Required of Intermountain.**

- 2.1.1 Intermountain Representative. Intermountain will designate an Intermountain Representative authorized to act in Intermountain's behalf with respect to the Project. Intermountain or such authorized representative will furnish to Contractor information or services Intermountain is required to furnish under the Contract Documents within a reasonable time in order to avoid a delay in the orderly and sequential progress of the Work.
- 2.1.2 Specialists and Inspectors. Intermountain reserves the right (but without obligation to provide building inspection services. This may include 'routine' and 'special' inspections. Intermountain may assign an inspector or specialist to note deviations from, or necessary adjustments to, the Contract Documents or to report deficiencies or defects in the Work. The inspector or specialist's activities in no way relieve Contractor of the responsibilities set forth in the Contract Documents.
- 2.1.3 Inspections. Intermountain and its representatives will have the right to inspect any portion of the Work wherever located at any time; provided that in no event will Intermountain be deemed to have assumed any obligation or liability whatsoever as a result of any such observation.
- 2.1.4 Surveys and Legal Description. Intermountain will furnish surveys describing the property lines and benchmarks for grading. Contractor will review this information, including the surveys and any provided geotechnical studies, and compare such information with observable physical conditions and the Contract Documents.
- 2.1.5 Prompt Information and Services. Upon receipt of a written request from Contractor, Intermountain will furnish information or services under Intermountain's control with reasonable promptness to avoid delay in the orderly progress of the Work.
- 2.1.6 Copies of Drawings and Project Manuals (for Construction). Unless otherwise provided in the Contract Documents, Contractor will be furnished electronic copies of Drawings and Project Manuals for Contractor's use in connection with the execution of the Work for the Project. Contractor will be responsible for making any further needed copies of the Construction Documents, subject to the copyright requirements.

### **2.2 Construction by Intermountain or By Separate Contractors.**

- 2.2.1 Intermountain's Right to Perform Construction and to Award Separate Contracts.
  - a. *In General.* Intermountain reserves the right to perform construction or operations related to the Project with Intermountain's own forces, and to award separate contracts related to the Project or other construction or operations on the site.
  - b. *Coordination and Revisions.* Intermountain will provide for coordination of the activities of Intermountain's own forces and of each separate contractor with the Work of Contractor, who will cooperate with them. Contractor will promptly notify in writing if any such independent

action will in any way compromise Contractor's ability to meet Contractor's responsibilities under the Contract. Contractor will participate with other separate contractors and Intermountain in reviewing their construction schedules when directed to do so. Contractor will make any revisions to the construction schedule and Contract Sum deemed necessary after a joint review and agreement by Intermountain. The construction schedules will then constitute the schedules to be used by Contractor, separate contractors and Intermountain until subsequently revised.

#### 2.2.2 Mutual Responsibility.

- a. *Contractor Coordination.* Contractor will afford Intermountain and separate contractor(s) a reasonable opportunity for delivery and storage of their materials and equipment and performance of their activities and will connect and coordinate Contractor's construction and operations with theirs where applicable.
- b. *Reporting Problems to Intermountain.* If part of Contractor's Work depends on work by Intermountain or a separate contractor, Contractor will, before proceeding with that portion of the Work, inspect and promptly report in writing to Intermountain apparent discrepancies or defects in workmanship that would render it unsuitable for proper execution, performance, or results. Failure of Contractor to so inspect and make this report will constitute an acceptance and acknowledgment that Intermountain's or separate contractors completed or partially completed construction is fit and proper to receive Contractor's Work, except as to defects in workmanship not then reasonably discoverable.
- c. *Costs.* Costs caused by delays or by improperly timed activities or Defective construction will be borne by the responsible party in accordance with the procedures and provisions of the Contract Documents.
- d. *Contractor Remedial Work.* Contractor will promptly remedy damage caused by Contractor or any Subcontractor to completed or partially completed work of Intermountain or of separate contractors or to the property of Intermountain or separate contractors and subcontractors.
- e. *Intermountain's Right to Clean Up.* If a dispute arises among Contractor and separate contractors as to the responsibility under their separate contracts for maintaining the Project free from waste materials and rubbish, Intermountain may clean the Project, allocate the cost among those responsible as Intermountain and A/E determine to be just, and withhold such cost from any amounts due or to become due to Contractor.

### 3. A/E.

#### 3.1 A/E's Administration of the Contract.

- 3.1.1 In General. A/E assists Intermountain with the administration of the Contract as described in the Contract Documents.
- 3.1.2 Site Visits. Site visits or inspections by A/E, Intermountain or any Intermountain representative will in no way limit or affect Contractor's responsibility to comply with all the requirements and the overall design concept of the Contract Documents as well as all applicable laws, statutes, ordinances, resolutions, codes, rules, regulations, orders and decrees. A/E will promptly submit to Intermountain a written report subsequent to each site visit.
- 3.1.3 Communications Facilitating Contract Administration. Except as authorized by Intermountain or as otherwise provided in the Contract Documents, including these General Conditions, A/E and Contractor will communicate through the Intermountain Representative on issues regarding the timing of the Work, cost of the Work, and scope of the Work. Contractor will comply with communication policies agreed upon at any pre-construction meeting with Intermountain. Communications by and with A/E sub-consultants will be through A/E. Communications by and with



Subcontractors will be through Contractor. Communications by and with separate contractors will be through Intermountain.

3.1.4 A/E May Reject Work, Order Inspection, Tests. A/E will have the authority to reject Work which, based upon A/E's knowledge or what may be reasonably inferred from A/E's site observations and review of data, does not conform to the Contract Documents or is damaged or rendered unsuitable. Whenever A/E considers it necessary or advisable for implementation of the intent of the Contract Documents, A/E will have the authority to require additional inspections or testing of the Work in accordance with the provisions of the Contract Documents, whether or not such Work is fabricated, installed or completed. However, neither this authority of A/E nor a decision made in good faith either to exercise or not to exercise such authority will give rise to a duty or responsibility of A/E to Contractor, Subcontractors, their agents or employees or other persons performing portions of the Work, including separate contractors.

3.1.5 A/E Review Contractor's Submittals.

- a. Contractor will submit shop drawings, product data, and samples and other submittals required by the Contract Documents to A/E as required by the approved submittal schedule.
- b. A/E will review and approve or take other appropriate action upon Contractor's submittals such as Shop Drawings, Product Data and Samples, but only for the purpose of checking for conformance with the information and design concepts expressed in the Contract Documents. A/E action taken on a submittal will not constitute a Modification of the Contract.
- c. A/E's action will be taken no later than fifteen (15) Days following A/E's receipt of the submittal, unless agreed to otherwise by Contractor and Intermountain.
- d. Review of such submittals is not conducted for the purpose of determining the accuracy and completeness of other details such as dimensions and quantities or for substantiating instructions for installation or performance of equipment or systems, all of which remain the responsibility of Contractor as required by the Contract Documents.
- e. A/E's review of Contractor's submittals will not relieve Contractor of the obligations under the Contract Documents.
- f. A/E's review will not constitute approval of safety precautions or, unless otherwise specifically stated by A/E, of any construction means, methods, techniques, sequences or procedures.
- g. A/E's approval of a specific item will not indicate approval of an assembly of which the item is a component.
- h. When professional certification of performance characteristics of materials, systems or equipment is required by the Contract Documents, A/E will be entitled to rely upon such certifications to establish that the materials systems or equipment will meet the performance criteria required by the Contract Documents.

**3.2 Ownership and Use of A/E's Drawings, Specifications and Other Documents.** All Drawings, Specifications and other documents prepared by A/E are and will remain the property of Intermountain, and Intermountain will retain all common law, statutory and other reserved rights with respect thereto. These documents were prepared and are intended for use as an integrated set for the Project which is the subject of the Contractor's Agreement and constitute works made for hire. Contractor will not modify or use Contract Documents on any other project without the prior written consent of Intermountain. Intermountain may withhold its consent in its absolute discretion. Any non-permissive use or modification, by Contractor, Contractor's Subcontractors at any tier or anyone for whose acts Contractor is liable, will be at Contractor's sole risk. Contractor will hold harmless and indemnify Intermountain from and against any and all claims, actions, suits, costs, damages, loss, expenses and attorney fees arising out of such non-permissive use or modification by Contractor. Contractor and Subcontractors are granted a limited license to use and reproduce applicable portions of the Drawings, Specifications and other documents prepared by

A/E or Intermountain appropriate to and for use in the execution of their Work under the Contract Documents. All copies made under this license will bear the statutory copyright notice, if any, shown on the Drawings, Specifications and other documents prepared by A/E or Intermountain. Submittals or distributions necessary to meet official regulatory requirements or for other purposes relating to completion of the Project are not to be construed as a publication in derogation of Intermountain's copyright or other reserved rights.

4. **CONTRACTOR.** Contractor's duties include the professional services of a business, administrative and management consultant to Intermountain; including all budget, scheduling, quality, safety and all other services related to assuring compliance with the Contract Documents.

**4.1 Review of Contract Documents and Field Conditions by Contractor.** By executing the Contractor's Agreement, Contractor represents that it has visited the Project site, familiarized itself with the local conditions under which the Work is to be performed, and correlated its own observations with the requirements of the Contract Documents.

4.1.1 Reviewing Contract Documents, Information, Reporting Errors, Inconsistencies or Omissions.

- a. Contractor will carefully study and compare the Contract Documents with each other and with information available relating to the Project or furnished by Intermountain before commencing and during performance of each portion of the Work and will at once report to Intermountain and A/E any errors, inconsistencies or omissions it discovers. If Contractor performs any construction activity without such notice to Intermountain and A/E and before the resolution of the error, inconsistency or omission, Contractor will assume responsibility for such performance and will bear the attributable costs for correction.
- b. Contractor will give Intermountain and/or A/E notice of any additional drawings, specifications, or instructions required to define the Work in greater detail, or to permit the proper progress of the Work, sufficiently in advance of the need for information so as not to delay the Work.
- c. It is not Contractor's responsibility to ascertain that the Contract Documents are in accordance with requirements of applicable laws, statutes, ordinances, building codes, rules and regulations. However, if Contractor observes that portions of the Contract Documents are at variance with those requirements, Contractor will immediately notify Intermountain and/or A/E in writing. Contractor will not proceed unless Intermountain and/or A/E effects Modifications to the Contract Documents required for compliance with such requirements. Contractor will be fully responsible for any work knowingly performed contrary to such requirements and will fully indemnify Intermountain against loss and bear all costs and penalties arising therefrom.

4.1.2 Field Conditions.

- a. Contractor will take field measurements and verify field conditions and will carefully compare such field measurements and conditions and other information known to Contractor, or information which a Contractor of ordinary skill and expertise for the type of Work involved would have known, before commencing activities. Errors, inconsistencies or omissions discovered will be reported to Intermountain and A/E at once. If Contractor performs any construction activity without such notice to Intermountain and A/E and before the resolution of the error, inconsistency or omission, Contractor will not be entitled to any compensation for additional costs attributable to correction or otherwise to Contractor resulting from field measurements or conditions different from those anticipated by Contractor which would have been avoided had Contractor taken field measurements and verified field conditions before ordering the materials or commencing construction activities.
- b. If site conditions indicated in the Contract Documents or other information provided by Intermountain or A/E to Contractor differ materially from those Contractor encounters in performance of the Work, Contractor will immediately notify Intermountain and/or A/E in writing of such differing site conditions.

- 4.1.3 Perform in Accordance with Contract Documents and Submittals. Contractor will perform the Work in accordance with the Contract Documents and submittals approved in accordance with the Contract Documents. Should Contractor or any of its Subcontractors become aware of any question regarding the meaning or intent of any part of the Contract Documents before commencing that portion of the Work about which there is a question, Contractor will request an interpretation or clarification from Intermountain and/or A/E before proceeding. Contractor proceeds at its own risk if it proceeds with the Work without first making such a request and receiving an interpretation or clarification from Intermountain and/or A/E.
- 4.1.4 Performance to Produce the Complete System and Intended Results. Performance by Contractor will be required to the extent consistent with the Contract Documents and reasonably inferable from the Contract Documents as being necessary to allow the system to function within its intended use.
- 4.1.5 Intent and Hierarchy. The Contract Documents should be read as a whole and wherever possible, the provisions should be construed in order that all provisions are operable. The intent of the Contract Documents is to include all items necessary for the proper execution and completion of the Work by Contractor. The Contract Documents are complimentary, and what is required by one Document or provisions thereof will be as binding as if required by all the Documents or provisions thereof. In case of an irreconcilable conflict between provisions within a Contract Document or between Contract Documents, the following priorities will govern as listed below:
- a. A particular Modification will govern over all Contract Document provisions or Modifications issued before this particular Modification.
  - b. A particular Addendum will govern over all other Contract Document provisions issued before this particular Addendum. Subsequent Addenda will govern over all prior Addenda.
  - c. The Supplementary Conditions will govern over the General Conditions.
  - d. The Agreement and these General Conditions will govern over all other Contract Documents except for the Supplementary Conditions, Addenda, Modifications.
  - e. The drawings and specifications will not govern over any of the documents listed above. The specifications take precedence over the drawings.
  - f. Within the Drawings, larger scale drawings take precedence over smaller scale drawings, figured dimensions over scaled dimensions, and noted materials over graphic indications.
  - g. In case of a conflict or ambiguity within the same level of hierarchy of described documents, Intermountain reserves the right to select the most stringent requirement unless the preponderance of the contract indicates the less stringent requirement.
- 4.1.6 Dividing Work and Contractor Representation. Organization of the specifications into divisions, sections and articles, and arrangement of Drawings, will not control Contractor in dividing the Work among Subcontractors or in establishing the extent of Work to be performed by any trade. Contractor represents that the Subcontractors, Sub-subcontractors, manufacturers and suppliers engaged or to be engaged by it are and will be familiar with the requirements for performance by them of their obligations. Where the Contract Documents require Contractor to provide professional services for architecture or engineering, Contractor will cause such services to be performed by appropriately licensed professionals.
- 4.1.7 Planning and Priority. Contractor will plan and schedule its work to facilitate the Project and will maintain a work schedule to place proper priority to sequence work to complete the project timely.
- 4.1.8 Prior to Contractor taking control over any area in any existing facility or on any project site, Contractor will provide prior written notice to Intermountain with sufficient time (no less than 30 Days) to allow Intermountain's Asset Recovery Team to remove, secure, and otherwise address existing materials, furniture, fixtures, equipment, and other assets located thereon.

## **4.2 Supervision and Construction Procedures.**

### **4.2.1 Supervision and Control.**

- a. Contractor will utilize its best skill, efforts, and judgment to provide efficient business administration and supervision, to furnish at all times an adequate supply of workers and materials, and to perform the Work in an expeditious and economical manner consistent with the interests of Intermountain.
- b. Contractor will supervise and direct the Work. Contractor will be solely responsible for all construction means, methods, techniques, sequences and procedures and for coordinating all portions of the Work.
- c. All loss, damage, liability, or cost of correcting Defective work arising from the use of any construction means, methods, techniques, sequences or procedures will be borne by Contractor, notwithstanding that such construction means, methods, techniques, sequences or procedures are referred to, indicated or implied by the Contract Documents, unless Contractor has given timely notice to Intermountain and A/E in writing that such means, methods, techniques, sequences or procedures are not safe or suitable, and Intermountain has then instructed Contractor in writing to proceed at Intermountain's risk.

4.2.2 **Responsibility.** Contractor will be responsible to Intermountain for acts and omissions of Contractor's employees, Subcontractors, and their agents and employees, and other persons performing portions of the Work under a contract with Contractor or on behalf of Contractor.

4.2.3 **Not Relieved of Obligations.** Contractor will not be relieved of obligations to perform the Work in accordance with the Contract Documents either by activities or duties of Intermountain or its agents in Intermountain's administration of the Contract, or by tests, inspections or approvals by Intermountain, A/E, or their consultants, or as required or performed by persons other than Contractor or for those that Contractor is liable.

### **4.2.4 Inspections and Approvals.**

- a. Contractor is responsible for requesting inspections for various stages and portions of the Work required under the Contract Documents in a timely manner.
- b. Contractor will be responsible for inspection of portions of the Work already completed to determine that such portions are in proper condition to receive subsequent portions of the Work.
- c. If any of the Work is required to be inspected or approved by the terms of the Contract Documents by any public authority, Contractor will timely request such inspection or approval to be performed in accordance with Article 9. Except as provided in Article 9, work will not proceed without any required inspection and the associated authorization to proceed. Contractor will promptly notify Intermountain if the inspector fails to appear at the site.

## **4.3 Labor and Materials.**

4.3.1 **Payment by Contractor.** Except to the extent it is otherwise stated in the Contract Documents, Contractor will provide and pay for labor, materials, equipment, tools, construction equipment and machinery, water, heat, utilities, transportation, and other facilities, supplies, consumables and services necessary for the proper execution and completion of the Work, whether temporary or permanent and whether or not incorporated or to be incorporated in the Work.

4.3.2 **Discipline and Competence.** Contractor will enforce strict discipline and good order among Contractor's employees, Subcontractors, agents, representatives and other persons performing under the Contract Documents. Contractor will not permit employment of unfit persons or persons not skilled in tasks assigned to them.

4.3.3 **Phased Construction / Accommodations for Facilities to Stay Operational.** Contractor and all Subcontractors will direct and perform the Work, phase and coordinate all construction and related

activities and timing, in a manner to preserve ongoing patient care and safety to all and to accommodate in every instance Intermountain's ongoing business operations such that facilities stay fully functioning, operational, and in compliance with applicable laws and regulations at all times.

**4.4 Taxes and Other Payments to Government.** Intermountain will pay all taxes and assessments on the real property comprising the Project site. Contractor will pay all applicable sales, consumer, use, payroll, workers compensation, unemployment, old age pension, surtax, and employment-related and similar taxes related to performance of the Work or portions thereof provided by Contractor which are legally enacted when bids are received or negotiations concluded, whether or not yet effective or merely scheduled to go into effect, and will comply with the laws and regulations regarding the payment of Sales and/or Use Tax and any applicable exemptions.

**4.5 Permits, Fees, Notices, Labor and Materials.**

**4.5.1 Permits and Fees.**

- a. Intermountain will obtain and pay for all zoning and use permits and permanent easements necessary for completion of the Work.
- b. Contractor will obtain and pay for the building permit, and all other permits, governmental fees, licenses and inspections necessary for the proper execution and completion of the Work.
- c. Contractor will secure any certificates of inspection and of occupancy required by authorities having jurisdiction over the Work. Contractor will deliver these certificates to A/E before issuance of the Certificate of Substantial Completion by A/E.

**4.5.2 Compliance with Law, Public Authorities, Notices.** Contractor will comply with all applicable federal, state and local laws, statutes, ordinances, resolutions, rules, regulations, codes, and lawful orders of public authorities.

**4.5.3 Correlation of Contract Documents and Enactments.**

- a. It is not Contractor's responsibility to ascertain that the Contract Documents are in accordance with applicable laws, statutes, ordinances, resolutions, building codes, and rules and regulations. Notwithstanding this, if Contractor observes, or if such is readily observable to a Contractor of ordinary skill and expertise for the type of Work involved, that a portion of the Contract Documents is at variance therewith, Contractor will promptly notify A/E and Intermountain in writing, and necessary changes will be accomplished by appropriate Modification.
- b. Contractor will coordinate and supervise the work performed by Subcontractors so that the Work is carried out without conflict between trades and so that no trade, at any time, causes delay to the general progress of the Work. Contractor and all Subcontractors will at all times afford each trade, any separate contractor, or Intermountain, reasonable opportunity for the installation of Work and the storage of materials.
- c. Contractor is fully responsible for the Project and all materials and work connected therewith until Intermountain has accepted the Work in writing. Contractor will replace or repair at its own expense any materials or work damaged or stolen, regardless of whether it has received payment for such work or materials from Intermountain.
- d. Contractor will remedy all damage or loss to any property caused in whole or in part by Contractor, any Subcontractor, or by anyone for whose acts any of them may be liable.
- e. Intermountain may elect to purchase materials required for the Work. In that event, Contractor will comply with the procedures set forth in the Contract Documents relating to such materials.

**4.5.4 Failure to Give Notice.** If Contractor, or any Subcontractor thereof performs Work without complying with the requirements of this Article 4.5 hereinabove, Contractor will assume appropriate responsibility for such Work and will bear the appropriate amount of the attributable costs.

#### 4.5.5 Intermountain-Purchased Materials and Equipment.

- a. In addition to Contractor's other obligations with respect to separate Intermountain provided work or materials, Contractor's obligations and duties with respect to Intermountain-purchased materials, equipment, and work include:
  - (i) Scheduling: The Contractor shall furnish Intermountain with a schedule of dates on which the Contractor requires delivery of Intermountain-purchased materials. Intermountain will arrange for the materials to be delivered to the construction site or picked up by Contractor on or before the specified dates. If delivery or pick up dates are changed, rescheduled, or otherwise varied from the original schedule, the Contractor shall notify Intermountain in writing of delivery or pick up date rescheduling and the Contractor shall coordinate the delivery or pick up of the Intermountain-purchased materials or equipment directly with the supplier.
  - (ii) Equipment / Vehicles: If Intermountain buys equipment or vehicles for Contractor's use on the Project, Contractor will (in addition to all other obligations herein relative to such equipment or vehicles) be fully and solely responsible for such equipment and vehicles as well as the use and use consequences thereof for any and all purposes (including without limitation to protect, secure, inspect, upkeep and make repairs, and insure such equipment and vehicles as well as to monitor, guide, direct, oversee, protect, and control the use and use consequences of such equipment and vehicles) until completion of the Project and Contractor's return of such equipment and/or vehicles to Intermountain.
  - (iii) Pre-Installation Inspection: The Contractor shall be responsible for receiving, inspecting and storing all Intermountain- purchased materials and equipment until the materials or equipment are needed for installation or use by the Contractor. Regardless of any inspection performed by Intermountain of the Intermountain-purchased materials or equipment, the Contractor shall be responsible for inspecting the Intermountain-purchased materials and equipment to determine suitability, quality and conformance with specifications before installation or use or at such other times as the Contractor may desire in order to avoid interruptions and delays in the progress of the Project. The Contractor shall reject any material which does not meet specifications or which appears to have any defect which may make the material unsuitable for use in the Project. The Contractor shall notify Intermountain and the manufacturer or supplier of all defects and assist Intermountain in arranging for the repair, replacement or correction of the defective condition. The Contractor shall not be entitled to an extension of any deadline or completion date which results from failure to discover defects which the Contractor should have discovered through an inspection.
  - (iv) Defective Materials: The Contractor acknowledges that use of improper or defective material may result in costs and damages to Intermountain in excess of the value of the materials; that after use in the Project it may be difficult or impossible to inspect the material to determine the cause of any failure; and that in the event of the failure of material there may be a question as to the cause of the failure. Because the Contractor's employees will be the last to handle and inspect material prior to incorporation into the Project, the Contractor will be liable to Intermountain for damages resulting from failure of Intermountain- purchased materials during the Contractor's warranty period specified herein from any cause whatsoever unless the Contractor provides clear and convincing proof that (1) the entire loss from a failure is covered by a valid manufacturer's or supplier's warranty, or (2) the Contractor could not have prevented the failure by complying with the requirements of this Section concerning Intermountain-purchased materials.
  - (v) Claims: The Contractor agrees to assist Intermountain to present claims to manufacturers and suppliers for defects in Intermountain-purchased materials. Where there is any question as to the division of liability between the Contractor and a manufacturer or vendor, the

Contractor shall provide all relevant information in the Contractor's possession which may aid Intermountain in determining the division of responsibility. Intermountain shall have final approval of any proposed adjustment or settlement of warranty claims.

- (vi) Implied Warranties: The benefit of contractual and implied warranties with respect to Intermountain-purchased materials and equipment shall run to Intermountain and not to the Contractor.
  - (vii) Unloading: Except as otherwise provided herein, the Contractor shall be responsible for unloading all Intermountain-purchased materials and equipment and for verifying delivery amounts to Intermountain.
  - (viii) Custody and Security: The Contractor shall secure and protect Intermountain-purchased materials and equipment from loss, deterioration, damage, theft, vandalism or destruction. If any Intermountain-purchased materials or equipment are damaged, stolen, or lost, Contractor will timely replace such at Contractor's sole cost and expense. In such event, Contractor will not be entitled to any modification in Contract Time or Contract Sum.
  - (ix) Reports: At Intermountain's request, the Contractor shall furnish reports to the Intermountain Representative demonstrating the Contractor's compliance with this Section.
  - (x) Retained Ownership: All materials and equipment purchased by Intermountain which remain after completion of the Project shall be the property of Intermountain. If Intermountain does not wish to retain or dispose of surplus Intermountain-purchased materials or equipment, the Contractor shall remove and dispose of them.
- b. None of the foregoing duties of the Contractor with respect to Intermountain-purchased materials shall prevent Intermountain from exercising any prerogative of ownership of the materials or equipment.

**4.6 Superintendent.** Contractor will employ a competent superintendent and necessary assistants who will be in attendance at the Project site at all times during performance of the Work. The superintendent will represent Contractor, and communications given to the superintendent will be as binding as if given to Contractor. Important communications will be confirmed in writing. Other communications will be similarly confirmed on written request in each case.

#### **4.7 Time and Contractor's Construction Schedules.**

##### **4.7.1 Progress and Completion.**

- a. *Time Is of The Essence; Complete Within Contract Time.* Time is of the essence. By executing the Contractor's Agreement, Contractor confirms that the Contract Time is adequate to perform the Work. Contractor will proceed expeditiously with adequate forces to achieve Substantial Completion within the Contract Time.
- b. *Notice to Proceed and Insurance.* Contractor will not prematurely commence operations on the site or elsewhere before the issuance of a Notice to Proceed by Intermountain and in no event before the effective date of insurance required by Article 10 to be furnished by Contractor. In addition and without limitation of the foregoing, Contractor will not proceed with further Work or services after performing preconstruction services until Contractor receives a subsequent Notice to Proceed.

4.7.2 **Schedule Preparation.** Contractor, promptly after being awarded the Contract, will prepare and submit for Intermountain's and A/E's review a reasonably detailed CPM schedule for the Work. The schedule will indicate the order, sequence, and interdependence of all items known to be necessary to complete the Work including construction, procurement, fabrication, and delivery of materials and equipment, submittals and approvals of samples, shop drawings, procedures, or other documents.

Work items of Intermountain, other Contractors, utilities and other third parties that may affect or be affected by Contractor will be included. If Intermountain is required, by the Contract Documents, to furnish any materials, equipment, or the like, to be incorporated into the Work by Contractor, Contractor will submit, with the first schedule submittal, a letter clearly indicating the dates that such items are required at the Project site. The critical path should be identified, including the critical paths for interim completion dates and milestones. The CPM schedule will be developed using Primavera, MS Project, or Suretrack unless otherwise authorized by Intermountain Representative. Contractor's schedule will be updated at least once per month and submitted with each pay request. Contractor will maintain an original baseline schedule and will provide Intermountain monthly written reports indicating Contractor's compliance or noncompliance with the original schedule.

- 4.7.3 Initial Contract Time. Unless otherwise specified in the bidding documents, the initial Contract Time is the time identified in the Contractor's Agreement.
- 4.7.4 Interim Completion Dates and Milestones. The schedule must include contractually specified interim completion dates and milestones. The milestone completion dates indicated are considered essential to the satisfactory performance of this Contract and to the coordination of all Work on the Project. The milestone dates listed are not intended to be a complete listing of all Work under this Contract or of interfaces with other Project contractors.
- 4.7.5 Schedule Content Requirements. The schedule will indicate an early completion date for the Project that is no later than the Project's required completion date. The schedule, including all activity duration's will be given in calendar days. The Schedule will also indicate all of the following:
- a. Interfaces with the work of outside contractors (e.g., utilities, power and with any separate Contractor);
  - b. Description of activity including activity number/numbers;
  - c. Estimated duration time for each activity;
  - d. Early start, late start, early finish, late finish date, and predecessor/successors including stop-start relationships with lead and lag time for each activity;
  - e. Float time available to each path of activities;
  - f. Actual start date for each activity begun;
  - g. Actual finish date for each activity completed;
  - h. The percentage complete of each activity in progress or completed;
  - i. Identification of all critical path activities;
  - j. The critical path for the Project, with this path of activities being clearly and easily recognizable on the time-scaled network diagram. The path(s) with the least amount of float time must be identified. Unless otherwise authorized by Intermountain Representative, no more than 40% of all activities may be identified as critical path items. The relationship between non-critical activities and activities on the critical path will be clearly shown on the network diagram;
  - k. Unless otherwise authorized by Intermountain Representative, all activities on the schedule representing construction on the site may not have duration longer than fourteen (14) Days. Construction items that require more than fourteen (14) Days to complete must be broken into identifiable activities on the schedule with durations less than fourteen (14) Days. The sum of these activities represents the total length required to complete that construction item; and
  - l. Additional requirements as specified in the Supplemental General Conditions.



- 4.7.6 Intermountain's Right to Take Exceptions. Intermountain reserves the right to take reasonable exception to activity duration, activity placement, construction logic or time frame for any element of the Work to be scheduled.
- 4.7.7 Float Time. Float time is defined as the amount of time between the earliest start date and the latest start date or between the earliest finish date and the latest finish date of a chain of activities on the Schedule. By a proposal request or modification delivered to Contractor, Intermountain has the right to use the float time for non-critical path activities until Contractor has reallocated such time on a newly submitted schedule.
- 4.7.8 Initial Schedule Submission. No progress payments will be approved until Contractor has submitted a Project detailed CPM schedule for the entire project.
- 4.7.9 Updates. Before any approval of a pay request, Intermountain, A/E and Contractor will review Contractor's schedule compared to the Work completed. Intermountain approves the amount of Work completed as supported by the schedule of values and as verified by the determination of Work completed. If necessary, Contractor will then update and submit to Intermountain the schedule with the pay request; all of which in accordance with Intermountain's approval. All updates will be provided in electronic and hard copy formats. At each scheduled meeting with Intermountain Representative, Contractor will provide at minimum a "three week look ahead" with long lead items identified.
- 4.7.10 Schedule of Submittals. Contractor will prepare and keep current, for A/E's and Intermountain's review, a schedule of submittals required under the Contract Documents which is coordinated with Contractor's construction schedule and allows A/E a reasonable time to review the submittals. This submittal schedule is to be included as part of the construction schedule. Submittals requiring expedited review must be clearly identified as such in the schedule of submittals.
- 4.7.11 Schedule Recovery. If the Work represented by the critical path falls behind by more than seven (7) Days, the project schedule will be redone within fourteen (14) Days showing how Contractor will recover the time. A narrative that addresses the changes in the schedule from the previously submitted schedule will be submitted along with the schedule in both hard copy (appropriate report formats to be determined by Intermountain Representative) and electronic copy. Contractor will comply with the most recent schedules.
- 4.7.12 Schedule Changes and Modifications.
- a. *Contract Time Change Requires Modification*. The Contract Time may only be shortened or extended by a Modification fully executed by Intermountain.
  - b. *Contractor Changing Activity Durations*. Should Contractor, after approval of the complete detailed construction schedule, desire to change his plan of construction, he will submit his requested revisions to Intermountain and A/E along with a written statement of the revisions including a description of the sequence and duration changes for rescheduling the work, methods of maintaining adherence to intermediate milestones and the contract completion date and the reasons for the revisions. If the requested changes are acceptable to Intermountain, which acceptance will not be unreasonably withheld, they will be incorporated into the Schedule in the next reporting period. If after submitting a request for change in the Contract Schedule, Intermountain does not agree with the request, Intermountain will schedule a meeting with Contractor to discuss the differences.
  - c. *Changes in Contract Time*. The critical path schedule as the term is used in the provisions herein will be based on the current version of Contractor's schedule for the Project and accepted by Intermountain just before the commencement of the modification, asserted delay, suspension or interruption. If Contractor believes it is entitled to an extension of Contract Time under the

Contract Documents, Contractor will submit a PCO in accordance with Article 7.2 to A/E and Intermountain Representative accompanied by an analysis of the requested time adjustment.

4.7.13 Extensions of Time.

- a. If Substantial Completion of the Project is delayed because of any of the following causes, then the Contract Time will be extended by Modification for a period of time equal to such delay:
  - (i) Labor strikes or lock-outs;
  - (ii) Unusual delay in transportation;
  - (iii) Unforeseen governmental requests or requirements;
  - (iv) A Change in the Work resulting from an instruction by Intermountain or A/E to Contractor subject to the conditions set forth in Section 7.1.5;
  - (v) Unforeseen Subsurface Condition subject to the conditions set forth in Section 7.1.6; or
  - (vi) Any other event or circumstance caused by the willful or negligent act or omission of Intermountain or A/E subject to the conditions set forth in Section 7.1.6.
- b. Contractor will not be entitled to any compensation for delay described in Section 4.7.13, Paragraph a, subparagraphs (i), (ii), and (iii).
- c. In no event will any time extension or cost adjustment be given on account of delay which reasonably should have been anticipated by the Contractor or in circumstances where performance of the Work is, was, or would have been, delayed by any other cause for which the Contractor is not entitled to an extension.
- d. Adverse Weather delays. Completion time will not be extended for normal bad weather or any weather that is reasonably foreseeable at the time of entering into the contract. The time for completion as stated in the contract documents includes due allowance for calendar days on which Work cannot be performed due to weather conditions. The Contractor acknowledges that it may lose days due to weather conditions. Notwithstanding, the Contract Time may be extended (but at no cost to Intermountain) if all of the following are established by the Contractor:
  - (i) That the weather prevented Work from occurring that is on the critical path for the project based upon a critical path schedule previously submitted to Intermountain and to the extent accepted by Intermountain;
  - (ii) There are no concurrent delays attributed to the Contractor;
  - (iii) The Contractor took all reasonable steps to alleviate the impact of the weather and took reasonable attempts to prevent the delay and despite such reasonable actions of Contractor, the weather impacted the critical path as described above; and
  - (iv) One of the following occurred:
    1. The weather was catastrophic, such as a tornado, hurricane, severe wind storm, severe hail storm; or
    2. Based on the full history of information published from the closest station as indicated from the Western Regional Climate Center (Desert Research Institute 2215 Raggio Parkway Reno, Nevada 89512, and as may be described on the website at <http://www.wrcc.dri.edu/summary/>), one or more of the following occurred:
      - a. For any day between November 1 and March 31, the minimum temperature fell below the average minimum temperature plus the extreme low temperature recorded for the month divided by 2.
      - b. For any day between November 1 and March 31, the maximum temperature fell below the monthly average for the minimum temperature.

- c. The daily precipitation exceeded 75% of the historical one day maximum for the month.
- d. The snowfall for the month exceeded 175% of the historical average snow fall for the month.

Contractor will not be entitled to any compensation for Adverse Weather.

4.7.14 Time Extension Request. Unless a shorter time period is set forth herein or in other Contract Documents, any time extension will be requested by Contractor within twenty-one (21) Days after Contractor knew or should have known about the delay and will be supported by the critical path schedule analysis.

4.7.15 Delay in Completion of the Work.

- a. *Prior to Substantial Completion*. For each Day after the expiration of the Contract Time that Contractor has not achieved Substantial Completion, Contractor will pay Intermountain the amount set forth in the Agreement as liquidated damages for Intermountain's loss of use of the Project and the added administrative expense to Intermountain to administer the Project during the period of delay. In addition, Contractor will reimburse Intermountain for any additional Consultant's fees, attorney fees, expert fees, consultant fees, copy costs, and other expenses incurred by Intermountain as a result of the delay. The parties have agreed on this liquidated damages provision because actual damages which will result from a delay in Substantial Completion cannot readily be ascertained at the time of execution of the Agreement and the parties wish to fix such damages as a their reasonable estimate of such actual damages, and not as a penalty. Intermountain may deduct any liquidated damages or reimbursable expenses from any money due or to become due to Contractor. If the amount of liquidated damages and reimbursable expenses exceeds any amounts due to Contractor, Contractor will pay the difference to Intermountain within ten (10) Days after receipt of a written request from Intermountain for payment
- b. *After Substantial Completion*. For each Day that Contractor exceeds the time allowed for completion of the remaining items set forth in the Certificate of Substantial Completion, Contractor will pay to Intermountain as liquidated damages for additional administrative expenses the amount set forth in the Agreement. In addition, Contractor will reimburse Intermountain for any additional Consultant's fees, attorney fees, expert fees, consultant fees, copy costs, and other expenses incurred by Intermountain as a result of the delay in completing such items.
- c. *No Waiver of Intermountain's Rights*. Permitting Contractor to continue any part of the Work after the time fixed for completion or beyond any authorized extension thereof, will in no way operate as a waiver or estoppel on the part of Intermountain of any of its rights under the Contract Documents, including the right to liquidated damages or any other remedies or compensation.

**4.8 Documents and Samples at the Site; Certifying "As-Built"**. Contractor will maintain at the site for Intermountain, one record copy of the Drawings, Specifications, Addenda, Change Orders and other Modifications, in good order and marked weekly to record changes and selections made during construction, as well as approved Shop Drawings, Product Data, Samples and similar submittals. These items will be available to A/E and will be delivered to A/E for submittal to Intermountain upon completion of the Work, or upon completion of any phase of the Work as agreed to by the parties, signed by Contractor, certifying that they show complete and exact "as-built" conditions and location, stating sizes, kind of materials, vital piping, conduit locations and similar matters. All notes of encountered or changed conditions will be included.

#### **4.9 Shop Drawings, Product Data and Samples.**

- 4.9.1 Not Contract Documents. Shop Drawings, Product Data, Samples and similar submittals are not Contract Documents. The submittal will demonstrate, for those portions of the Work for which the submittal is required, the way Contractor proposes to conform to the information given and the design concept expressed in the Contract Documents.
- 4.9.2 Promptness. Contractor will review, approve and submit to A/E, Shop Drawings, Product Data, Samples and similar submittals required by the Contract Documents with reasonable promptness and in such sequence as to cause no delay in the Work, or the activities of Intermountain or separate contractors.
- 4.9.3 Not Perform Until A/E Approves. Contractor will perform no portion of the Work requiring submittal and review of Shop Drawings, Product Data, Samples or similar submittals until the respective submittal has been approved in writing by A/E. Such Work will be in accordance with the approved submittals.
- 4.9.4 Representations by Contractor. By approving and submitting Shop Drawings, Product Data, Samples and similar submittals, Contractor represents that Contractor has determined and verified materials, field measurements and field construction criteria related thereto, and has checked and coordinated the information contained within such submittals with the requirements of the Work and of the Contract Documents.
- 4.9.5 Contractor's Liability. Contractor will not be relieved of responsibility for deviations from the requirements of the Contract Documents by A/E's approval of Shop Drawings, Product Data, Samples or similar submittals unless Contractor has specifically informed A/E in writing of such deviation at the time of the submittal and A/E has given written approval to the specific deviation. Contractor will not be relieved of responsibility for errors or omissions in Shop Drawings, Product Data, Samples or similar submittals by A/E's review and comment.
- 4.9.6 Direct Specific Attention to Revisions. Contractor will direct specific attention in writing to all revisions on resubmitted Shop Drawings, Product Data, Samples or similar submittals, except those requested by A/E and indicated on previous submittals.
- 4.9.7 Informational Submittals. Informational submittals upon which A/E is not expected to take responsive action may be so identified in the Contract Documents.
- 4.9.8 Reliance on Professional Certification. When professional certification of performance criteria of materials, systems or equipment is required by the Contract Documents, Intermountain and A/E will be entitled to rely upon the accuracy and completeness of such calculations and certifications. If a professional stamp is required, the professional will be licensed in the State in which the Project is located unless otherwise approved by Intermountain in writing. Likewise, Contractor is entitled to rely upon the accuracy and completeness of the calculations made by A/E in developing the Contract Documents, unless a Contractor of ordinary skill and expertise for the type of Work involved would know that such is inaccurate or incomplete and therefore must immediately notify Intermountain in writing.

#### **4.10 Use of Project Site.**

- 4.10.1 In General.
  - a. Intermountain may, in Intermountain's discretion, permit Contractor to occupy or otherwise use portions of the Project site or, if applicable and available, other Intermountain property within the vicinity of the Project, for general office, staging, or other purposes as more particularly provided in the Project Specifications. As used herein, the term "Project site" or "site" will be deemed to refer to any other Intermountain property used by Contractor in connection with the Project, in addition to the actual Project site. Intermountain may, in its discretion, require Contractor to enter into a separate license agreement, on Intermountain's standard form, with

respect to Contractor's occupancy or other use of Intermountain space at the actual Project site or within other Intermountain property.

- b. Contractor will confine operations at the site to areas permitted by the Contract Documents, law, ordinances, resolutions, rules and regulations, and permits and will not unreasonably encumber the site with materials or equipment. Contractor will take all reasonable means to secure the site, protect the site and protect the Work from any damage. The site will be left free and clear of refuse, equipment, materials, etc. and the site will not be subject to spilled liquids and chemicals, toxic or otherwise. Should such an incident occur while Contractor has control of the site, Contractor will be responsible to clean, repair, or restore the site and pay all associated costs, fines and penalties. Contractor will indemnify and hold Intermountain harmless from and against any and all loss, cost, damage, injury or expense, including claims for death or injury to person or damage to property, and including without limitation attorney's fees and court costs, to the extent arising out of or in connection with use of the site by Contractor or its contractors, employees, or invitees. Notwithstanding the foregoing, Contractor is not responsible for any damage to the site or the Work to the extent caused by Intermountain or Intermountain's agents.
- c. Contractor recognizes that the Project site and the surrounding area is frequently visited by the public and is important to Intermountain's image and function and will maintain the premises free from debris and waste materials resulting from Construction. At the completion of Construction, Contractor will promptly remove construction equipment, tools, surplus materials, waste materials and debris.

4.10.2 Access to Neighboring Properties. Contractor will not, except as provided in the Contract Documents or with Intermountain's advance written consent when necessary to perform the Work, interfere with access to properties neighboring the Project site by the owners of such properties and their respective tenants, agents, invitees and guests.

**4.11 Access to Work.** Contractor will provide Intermountain and A/E access to the Work in preparation and progress, wherever located.

**4.12 Royalties and Patents.** Contractor will pay all royalties and license fees. Contractor will defend suits or claims for infringement of patent rights and will hold Intermountain and A/E harmless from loss on account thereof, but will not be responsible for such defense or loss when a particular design, process or product of a particular manufacturer or manufacturers is required by the Contract Documents. However, if Contractor has reason to believe that the required design, process or product is an infringement of a patent, Contractor will be responsible for such loss unless such information is promptly furnished to Intermountain in writing.

**4.13 Indemnification.**

4.13.1 To the fullest extent permitted by law, Contractor will indemnify and hold harmless Intermountain and its affiliates, subsidiaries, officers, employees, agents, authorized volunteers (hereinafter the above listing of entities and persons is referred to as "indemnitees") from and against every kind and character of claims, liabilities, damages, losses, settlements, and expenses, including but not limited to attorneys' fees, consultant fees, expert fees, and other costs and expenses, and including without limitation those events covered under the blanket Contractual Liability Coverage required under the Contract Documents, arising out of or resulting from performance of the Work, including without limitation the work of all the Subcontractors and their employees, except to the extent that such liability arises out of the negligence of Intermountain, its representatives, agents, and employees. This indemnity includes, without limitation, indemnification of Intermountain from all losses or injury to Intermountain's property, except to the extent that such loss or injury arises out of the negligence of Intermountain, its representatives, agents, and employees. This indemnity applies, without

limitation, to include Claims occurring both during performance of the Work and/or subsequent to completion of the Work. In the event that any Claim is caused in part by a party indemnified hereunder, that party will bear the cost of such Claim to the extent it was the cause thereof. In the event that a claimant asserts a Claim for recovery against any party indemnified hereunder, the party indemnified hereunder may tender the defense of such Claim to Contractor. If Contractor rejects such tender of defense and it is later determined that the negligence of the party indemnified hereunder did not cause all of the Claim, Contractor will reimburse the party indemnified hereunder for all costs and expenses incurred by that party in defending against the Claim. Contractor will not be liable hereunder to indemnify any party for damages resulting from the sole negligence of that party. Notwithstanding, Intermountain will have the right, at its option, to participate in the defense of any such action without relieving Contractor of any obligation hereunder.

- 4.13.2 In addition to the foregoing, Contractor will be liable to defend Intermountain in any lawsuit filed by any Subcontractor relating to the Project. Where liens have been filed against Intermountain's property, Contractor (and/or its bonding company which has issued bonds for the Project) will obtain lien releases and record them in the appropriate county and/or local jurisdiction and provide Intermountain with a title free and clear from any liens of Subcontractors. In the event that Contractor and/or its bonding company are unable to obtain a lien release, Intermountain in its absolute discretion may require Contractor to provide a bond around the lien or a bond to discharge the lien, at Contractor's sole expense.
- 4.13.3 In addition to the foregoing, Contractor will indemnify and hold Intermountain harmless from any claim of any other contractor resulting from the performance, nonperformance or delay in performance of the Work by Contractor.
- 4.13.4 The indemnification obligation under this Article 4.13 will not be limited by a limitation on amount or type of damages, compensation or benefits payable by or for Contractor or Subcontractor under workers' or workmen's compensation acts, disability benefits acts or other employee benefit acts.
- 4.13.5 Intermountain and Contractor waive all rights against each other for damages to the Work during construction to the extent covered by the applicable Builder's Risk Policy, except such rights as they may have to the proceeds of such insurance as set forth in the Contract. Contractor will require similar waivers from its Subcontractors, subconsultants, and agents, at any tier.

**4.14 Additional Services/Work.** It is understood and agreed by the parties hereto that no money will be paid to Contractor for additional labor or materials furnished unless a new contract in writing or a Modification hereof in accordance with the General Conditions and the Contract Documents for such additional labor or materials has been executed. Intermountain specifically reserves the right to modify or amend the Contract and the total sum due hereunder, either by enlarging or restricting the scope of the Work.

**4.15 Building Information Modeling.** Contractor will perform, throughout the Project, as requested by Intermountain and/or as otherwise required to execute the Project, building information modeling ("BIM") services and coordination among trades. Such BIM services are included in Contractor's Work and services and shall be provided by Contractor and Subcontractors without additional fee or charge to Intermountain. Contractor will provide BIM services using software acceptable to Intermountain.

## **5. SUBCONTRACTORS.**

### **5.1 Award of Subcontracts and Other Contracts for Portions of the Work.**

#### **5.1.1 Approval Required.**

- a. Listing of Subcontractors will be as stated in the Contract Documents, including but not limited to the "Intermountain Subcontractors List Form".

- b. Contractor will not contract with a proposed person or entity to whom Intermountain has made a reasonable and timely objection. Contractor will not be required to contract with anyone to whom Contractor has made reasonable objection.
- 5.1.2 Business and Licensing Requirements. All Subcontractors used by Contractor will comply with all applicable business and licensing requirements.
- 5.1.3 Subsequent Changes. After the bid opening, Contractor may change its listed Subcontractors only in accordance with the Contract Documents and with written approval of the Director.
- a. Intermountain will pay the additional costs for an Intermountain requested change in Subcontractor if all of the following are met:
    - (i) If Intermountain in writing requests the change of a Subcontractor;
    - (ii) The original Subcontractor is a responsible Subcontractor that meets the requirements of the Contract Documents; and
    - (iii) The original Subcontractor did not withdraw as a Subcontractor on the project.
  - b. In all other circumstances, Contractor will pay the additional cost for a change in a Subcontractor.
- 5.1.4 Bonding of Subcontractors. Subcontractors as identified by Intermountain in the procurement documents, may be required to submit performance and payment bonds to cover the full extent of their portion of the Work. This provision does not in any way limit the right of Contractor to have Subcontractors at any tier be required to have a performance and/or payment bond.
- 5.1.5 Unrelated Subcontractors / Contractor Self-Performed Work.
- a. Contractor will procure bids for subcontract work from at least three (3) qualified bidders unless Intermountain waives such requirement in writing. Except as provided in the following section, Contractor will enter into contracts with Subcontractors not owned, related to or controlled by Contractor to perform all portions of the Work. Subcontracts will contain payment provisions consistent with the Contract Documents and will not be awarded on the basis of cost plus a fee without the prior written consent of Intermountain.
  - b. If Contractor wishes to self-perform any portion of the Work or subcontract such portion of the Work to an entity owned or controlled by or related to Contractor, Contractor will:
    - 1) Advise Intermountain at least thirty (30) Days in advance of bid opening that Contractor wishes to self-perform such Work or subcontract it to an entity owned, controlled by or related to Contractor and request Intermountain's written approval thereof;
    - 2) Submit to Intermountain Contractor's or such related entity's bid at least seventy-two (72) hours prior to bid opening;
    - 3) Procure bids for such subcontract Work from at least three qualified bidders unless Intermountain waives such requirement in writing; and
    - 4) Abide by Intermountain's determination as to whether Contractor or another subcontractor will be used to perform such Work.
  - c. If Intermountain both approves Contractor to self-perform Work and approves Contractor proceeding without obtaining bids from other Contractors, then Contractor's overhead and profit on Work performed by Contractor's crews will not be more than the percentage fee, if any, stated in the Contractor's Agreement or such fee as agreed by Intermountain and Contractor by

a written Modification executed prior to Contractor's commencing the applicable self-performed Work.

## **5.2 Subcontractual Relations.**

- 5.2.1 Comply with Contract Documents. By appropriate enforceable agreement, and to the extent it can be practically applied, Contractor will require each Subcontractor to be bound to Contractor by the terms of the Contract Documents, and to assume toward Contractor all the obligations and responsibilities which Contractor, by these Documents, assumes towards Intermountain and A/E.
- 5.2.2 Rights. Each Subcontractor agreement will preserve and protect the rights of Intermountain and A/E under the Contract Documents with respect to the Work to be performed by the Subcontractor so that subcontracting thereof will not prejudice such rights, and will allow to the Subcontractor, unless specifically provided otherwise in the Subcontractor agreement, the benefit of all rights and remedies against Contractor that Contractor, by the Contract Documents, has against Intermountain.
- 5.2.3 Sub-Subcontractors. Contractor will require each Subcontractor to enter into similar agreements with its Subcontractors which complies with the requirements of Paragraphs 5.2.1 and 5.2.2 hereinabove.
- 5.2.4 Document Copies. Contractor will make available to each proposed Subcontractor, before execution of the subcontract agreement, copies of the Contract Documents to which the Subcontractor will be bound. Subcontractors will similarly make copies of applicable portions of the Contract Documents available to their respective proposed Subcontractors.

**5.3 Contingent Assignment of Subcontracts.** Each subcontract agreement for a Subcontractor, at any tier for a portion of the Work, is hereby assigned by Contractor to Intermountain provided that the assignment is effective only after termination of the Contract by Intermountain for cause pursuant to Article 12.2 or stoppage of the Work by Intermountain pursuant to Article 12.5, and only for those subcontract agreements which Intermountain accepts by notifying the Subcontractor in writing. The subcontract will be equitably adjusted to meet the new conditions of the work.

## **6. PROTECTION OF PERSONS AND PROPERTY.**

### **6.1 Safety of Persons and Property.**

- 6.1.1 Contractor Responsibility. Contractor will be solely responsible for initiating, maintaining and supervising all safety precautions and programs in connection with the performance of the Contract. Contractor will take all reasonable precautions for the safety of, and will provide reasonable protection to prevent damage, injury or loss to:
  - a. Employees on the Work and other persons who may be affected thereby;
  - b. The Work and materials and equipment to be incorporated therein, whether in storage on or off the site, under care, custody or control of Contractor or a Subcontractor; and
  - c. Other property at the site or adjacent thereto, such as trees, shrubs, lawns, walks, pavements, roadways, structures and utilities not designated for removal, relocation or replacement in the course of construction.
- 6.1.2 Safety Program, Precautions. Contractor will institute a safety program at the start of construction to minimize accidents. This program will continue to the final completion of the Project and conform to applicable laws and regulations including the Utah Occupational Safety and Health Rules and Regulations as published by the Utah Industrial Commission - UOSH Division. Contractor will post signs, erect barriers, and provide those items necessary to implement the safety program. As soon as Contractor proceeds with the Work, Contractor will have all workers and all visitors on the site wear safety hard hats, as well as all other appropriate safety apparel such as safety glasses and shoes, and obey all safety rules and regulations and statutes. Contractor will post a sign in a conspicuous location indicating the necessity of wearing hard hats and Contractor will loan such hats to visitors.



- 6.1.3 Compliance with Safety Laws. Contractor will give notices and comply with applicable laws, ordinances, rules, codes, regulations and lawful orders of public authorities bearing on safety of persons or property or their protection from damage, injury or loss.
- 6.1.4 Erect and Maintain Safeguards. Contractor will erect and maintain, as required by existing conditions and performance of the Contract, reasonable safeguards for safety and protection, including effective fences, posting danger signs and other warnings against hazards, promulgating safety regulations and notifying owners and users of adjacent sites and utilities.
- 6.1.5 Utmost Care. When use or storage of explosives or other hazardous materials or equipment or unusual methods are necessary for execution of the Work, Contractor will exercise utmost care and carry on such activities under supervision of properly qualified personnel.
- 6.1.6 Prompt Remedy. Contractor will promptly remedy damage and loss (other than damage or loss insured under property insurance required by the Contract Documents) to property referred to in Paragraph 6.1.1 of these General Conditions caused in whole or in part by Contractor, a Subcontractor, or anyone directly or indirectly employed by any of them, or by anyone for whose acts they may be liable and for which Contractor is responsible under this Paragraph 6.1.1, except to the extent such damage or loss is directly due to errors in the Contract Documents or caused by agents or employees of A/E or Intermountain. The foregoing obligations of Contractor are in addition to Contractor's obligations under the Contract Documents.
- 6.1.7 Safety Designee. Contractor will designate a responsible member of Contractor's organization at the site whose duty will be the prevention of accidents, damage, injury or loss. This person will be Contractor's superintendent unless otherwise designated by Contractor in writing to Intermountain and A/E.
- 6.1.8 Load Safety. Contractor will not load or permit any part of the construction or site to be loaded so as to endanger its safety.
- 6.1.9 Off-Site Responsibility. In addition to its other obligations under this Article 6, Contractor will, at its sole cost and expense, promptly repair any damage or disturbance to walls, utilities, streets, ways, sidewalks, curbs and the property of Intermountain and third parties (including municipalities and other governmental agencies) resulting from the performance of the Work, whether by it or by its Subcontractors at any tier. Contractor will not cause materials, including soil and debris, to be placed or left on streets or ways.
- 6.1.10 Emergencies. In an emergency affecting safety of persons or property, Contractor will act, at Contractor's discretion, to prevent threatened damage, injury or loss. Contractor will promptly notify Intermountain Representative of the action taken.
- 6.2 Hazardous Materials.** In the event Contractor encounters on the site material reasonably believed to be asbestos or polychlorinated biphenyl (PCB) or any other hazardous waste or substance which may endanger the health of those persons performing the Work or being on the site, Contractor will immediately stop Work in the area affected and immediately report the condition to Intermountain Representative and A/E by phone with a follow-up document in writing. The Work in the affected area will be resumed when written direction is provided by Intermountain Representative. Except to the extent provided otherwise in the Contract Documents or if the presence of hazardous materials is due to the fault of Contractor, Contractor will not be required to perform without Contractor's consent, any Work relating to asbestos, polychlorinated biphenyl (PCB) or any other hazardous waste or substance. Intermountain will procure a licensed abatement contractor qualified to remove the hazardous material. The abatement contractor will submit notification of demolition to the Utah Division of Air Quality. Abatement contractor will pay the notification fee. A copy of the hazardous material survey report will be available to all persons who have access to the construction site.

**6.3 Historical and Archeological Considerations.** In the event Contractor knows or should have known of any cultural, historical or archeological material that is either recognized as an item to be protected under Federal, State, or local law or regulation, or is an item of obvious value to Intermountain, Contractor will cease any work that would interfere with such discovery and immediately report the condition to Intermountain Representative and A/E by phone with a follow-up document in writing. Work will resume based upon the direction of Intermountain Representative. Contractor cooperation with any Intermountain recognized archaeologist or other cultural/historical expert is required.

**6.4 Contractor Liability.** If Contractor fails in any of its obligations in Articles 6.1 through 6.3 above, Contractor will be liable to any damages to Intermountain or any third party resulting from such noncompliance. Contractor will also be liable for any mitigation or restoration effort resulting from such noncompliance. To the extent all the following is met, Contractor may treat the discovery of such material similarly to an unforeseen condition:

- 6.4.1 The discovery of such material is reasonably unforeseeable given the site conditions that Contractor should have been aware;
- 6.4.2 The presence of such material was not identified in any part of the Contract Documents;
- 6.4.3 Contractor has undertaken all proper action to mitigate any impact of such discovery on the critical path or monies related to the Project;
- 6.4.4 The discovery affects the critical path or contract price from that which was contemplated by the Contract Documents; and
- 6.4.5 The requirements of 7.1.5 and the Contract documents are met.

## **7. MODIFICATIONS, REQUEST FOR INFORMATION, PROPOSED CHANGE ORDER, AND CLAIMS PROCESS.**

### **7.1 Modifications: In General.**

- 7.1.1 Types of Modifications and Limitations. Changes in the Work may be accomplished after execution of the Contract, and without invalidating the Contract, by Change Order, Construction Change Directive or ASI, subject to the limitations stated in this Article 7 and elsewhere in the Contract Documents. Contractor must have a written Modification executed by Intermountain under this Article 7 before proceeding with any Work sought to be an extra.
- 7.1.2 By Whom Issued. A Change Order or Construction Change Directive will be issued by Intermountain Representative. An ASI is issued by A/E. A/E will prepare Change Orders and Construction Change Directives with specific documentation and data for Intermountain's approval and execution in accordance with the Contract Documents, and may issue ASIs not involving an adjustment in the Contract Sum or an extension of the Contract Time which are not inconsistent with the intent of the Contract Documents.
- 7.1.3 Contractor to Proceed Unless Otherwise Stated. Changes in the Work will be performed under applicable provisions of the Contract Documents, and Contractor will proceed promptly, unless otherwise provided in the Change Order, Construction Change Directive or ASI.
- 7.1.4 Adjusting Unit Prices. If unit prices are stated in the Contract Documents or subsequently agreed upon, and if quantities originally contemplated are so changed in a PCO or Construction Change Directive that application of such unit prices to quantities of Work proposed will cause a substantial inequity to Intermountain or Contractor, the applicable unit prices may be equitably adjusted.
- 7.1.5 Changes in the Work Resulting From An Instruction by Intermountain or A/E to Contractor.
  - a. If Intermountain or A/E gives Contractor an instruction that modifies the requirements of the Contract Documents or delays Substantial Completion, Contractor may be entitled to an adjustment in the Contract Sum and/or the Contract Time. If compliance with the instruction

affects the cost to Contractor to perform the Work, the Contract Sum will be adjusted to reflect the reasonable increase or decrease in cost subject to the conditions set forth in Section 7.1.5, subparagraphs b through g. If compliance with the instruction delays Substantial Completion, the Contract Time will be extended for a period of time commensurate with such delay subject to the conditions set forth in Section 7.1.5, subparagraphs b through g and Section 4.7.13.

- b. If Contractor receives an instruction from Intermountain or A/E that Contractor considers to be a Change in the Work, Contractor, before complying with the instruction, will notify A/E in writing that Contractor considers such instruction to constitute a Change in the Work. If A/E agrees that compliance with the instruction will constitute a Change in the Work, Contractor will furnish a proposal for a Modification in accordance with Section 7.1.5 subparagraphs c and d. within ten (10) Days.
- c. If Contractor claims that it is entitled to an adjustment in the Contract Sum (including without limitation costs related to a time extension) as a result of an instruction by Intermountain or A/E, Contractor will furnish a proposal for a Change Order containing a price breakdown itemized as required by Intermountain. The breakdown will provide sufficient detail to allow Intermountain to determine any increase or decrease in Direct Costs as a result of compliance with the instruction. Any amount claimed for subcontracts will be supported by a similar price breakdown and will itemize the Subcontractor's profit and overhead charges. Profit and overhead will be subject to the markup limits for additional work, changes, or other Modification set forth in the Contractor's Agreement. Amounts due Intermountain as a result of a credit change will be the actual net decrease in the Contractor's Direct Costs to perform the Work as a result of the Change in the Work. Overhead and profit for the Modification will be calculated based on the net increase or decrease in Contractor's Direct Costs resulting from the Change in the Work.
- d. If Contractor claims that it is entitled to an adjustment in the Contract Time as a result of an instruction from Intermountain or A/E, Contractor will include in its proposal justification to support Contractor's claim that compliance with the instruction will delay Substantial Completion.
- e. Upon receipt of Contractor's proposal for Modification, A/E and Intermountain will determine whether to proceed with the Change in the Work. If A/E and Intermountain determine to proceed with the Change in the Work, they will execute a Change Order, a Construction Change Directive or a Field Change as appropriate.
- f. Contractor agrees that if it complies with an instruction from Intermountain or A/E without first giving written notice to A/E as provided in Section 7.15, subparagraph b, and receiving a Change Order, Construction Change Directive or Field Change, Contractor will not be entitled to any adjustment in the Contract Sum or the Contract Time as a result of the instruction and waives any claim therefor.
- g. If Contractor is instructed to perform work which it claims constitutes a Change in the Work but which Intermountain and A/E do not agree constitutes a Change in the Work, Contractor will comply with the instruction. Contractor may submit its claim for adjustment to the Contract Sum, the Contract Time, or both as a dispute pursuant to Section 7.7 within twenty-one (21) Days after compliance with the instruction. Contractor agrees that if it fails to submit its claim for resolution pursuant to Section 7.7 within twenty-one (21) Days after compliance with the instruction, then Contractor will not be entitled to any adjustment in the Contract Sum or the Contract Time as a result of the instruction and waives any claim therefor.

- h. Contractor agrees that it is responsible for submitting accurate cost and pricing data to support its Change Order Proposals. Intermountain will have the right to examine the Contractor's records to verify the accuracy and appropriateness of the pricing data used to price change order proposals.

7.1.6 **Change in the Work Resulting From An Event or Circumstance.**

- a. If an event or circumstance other than an instruction from Intermountain or A/E affects the cost to Contractor of performing the Work or delays Substantial Completion, Contractor may be entitled to an adjustment in the Contract Sum and/or the Contract Time. If the circumstance or event affects the cost to Contractor to perform the Work and is caused by a willful or negligent act or omission of Intermountain or A/E or an Unforeseen Subsurface Condition, the Contract Sum will be adjusted to reflect the reasonable increase or decrease in Contractor's cost to perform the Work resulting from the event or circumstance, subject to the conditions set forth in Section 7.1.6, subparagraphs b through f. If the event or circumstance delays Substantial Completion and is described in Section 4.7.13, the Contract Time will be extended for a period of time commensurate with such delay subject to the conditions set forth in such section. If the circumstance or event delays Substantial Completion and is caused by a willful or negligent act or omission of Intermountain or A/E or an Unforeseen Subsurface Condition, then Contractor will be compensated for costs incident to the delay in accordance with Section 7.1.6, subparagraphs b through g and Section 4.7.13.
- b. Contractor will not be entitled to any adjustment to the Contract Sum or other damages from Intermountain as a result of any event or circumstance unless the event or circumstance results from a willful or negligent act or omission of Intermountain or A/E.
- c. If a Change in the Work results from any event or circumstance caused by the willful or negligent act or omission of Intermountain or A/E or an Unforeseen Subsurface Condition, Contractor will give Intermountain Written Notice of such event or circumstance within twenty-four (24) hours after commencement of the event or circumstance so that Intermountain can take such action as is necessary to mitigate the effect of the event or circumstance. Contractor will not be entitled to any adjustment in either the Contract Time or the Contract Sum based on any damages or delays resulting from such event or circumstance during a period more than twenty-four (24) hours prior to Contractor giving such Written Notice to Intermountain.
- d. Contractor will submit in writing any claims for an adjustment in the Contract Time and/or the Contract Sum resulting from an event or circumstance within the time limits set forth below. In the event that Contractor fails to submit its claim in writing within the time limits set forth below, then Contractor agrees it will not be entitled to any adjustment in the Contract Time or the Contract Sum or to any other damages from Intermountain due to the circumstance or event and waives any claim therefor.
  - (i) Claims for an adjustment in the Contract Time due to Adverse Weather will be made within twenty-one (21) Days of the first Day of the occurrence of the Adverse Weather event in which the delay occurred.
  - (ii) Claims for an adjustment in the Contract Time and/or the Contract Sum due to any other circumstance or event will be submitted within seven (7) Days after the occurrence of the circumstance or event.
- e. If Contractor claims that it is entitled to an adjustment in the Contract Sum (including without limitation costs related to a time extension) because of an event or circumstance resulting from the willful or negligent act or omission of Intermountain or A/E or an Unforeseen Subsurface

Condition, Contractor will furnish a proposal for a Change Order containing a price breakdown as described in Section 7.1.5, subparagraph c. Any amount claimed for increased labor costs as a result of the event or circumstance must be supported by a certified payroll. Any claim for rented equipment or additional material costs must be supported by invoices.

- f. If Contractor claims that it is entitled to an adjustment in the Contract Time as a result of an event or circumstance, Contractor will include with its claim copies of daily logs, letters, shipping orders, delivery tickets, Project schedules, and other supporting information necessary to justify Contractor's claim that the event or circumstance delayed Substantial Completion.
- g. Within thirty (30) Days after receipt of Contractor's claim, A/E will either deny the claim or recommend approval to Intermountain. If Intermountain approves the claim, the adjustment in the Contract Time and/or Contract Sum will be reflected in a Change Order pursuant to Section 7.4 or a Construction Change Directive pursuant to Section 7.5. If Intermountain or A/E denies Contractor's claim, Contractor may submit its claim as a dispute pursuant to Section 7.7 within twenty-one (21) Days of receipt of the denial of the claim. If Contractor fails to submit its claim for resolution pursuant to Section 7.7 within the twenty-one (21) Day time period, then Contractor agrees it is not entitled to any adjustment in the Contract Time and/or Contract Sum or any other damages as a result of the event or circumstance and waives any claim therefor.

## **7.2 Contractor Initiated Requests.**

- 7.2.1 The Request for Information, RFI, Process and Time to File. Contractor may file an RFI with A/E regarding any concern which will assist Contractor in the proper completion of the Work including, but not limited to issues related to the Contract Documents, plans and specifications. The RFI will be filed with A/E in a timely manner so as not to prejudice Intermountain as to the quality, time or money related to the Work.
- 7.2.2 Proposed Change Order. Unless a shorter time period is set forth herein or in other Contract Documents, within twenty-one (21) Days after Contractor knows or should have known of a situation or concern where Contractor is going to request additional monies or time, Contractor must file a PCO with Intermountain Representative, or Contractor will be deemed to waive any right to claim additional monies or time related to such situation or concern. The PCO will include all available documentation supporting the PCO available to Contractor at the time of filing and Contractor will thereafter diligently pursue the supplementation(s) of such documentation and promptly deliver such supplementation(s) to Intermountain Representative.
  - a. *Intermountain Representative Response.* One of the following may occur after a PCO is filed with Intermountain Representative:
    - (i) Intermountain Representative, after considering any input by A/E, may reach an agreement with Contractor and issue a Change Order.
    - (ii) Intermountain, after considering any input by A/E, may issue a Construction Change Directive.
    - (iii) If Intermountain Representative, after considering any input by A/E, disagrees with Contractor's PCO, Intermountain representative may seek additional information or verification from Contractor, A/E or other sources, may negotiate with Contractor, may issue a Change Order upon such later agreement, may retract the PR, or may issue a Construction Change Directive. A/E must continually work with Intermountain in providing data, documentation and efforts to resolve the issues related to the PR.

**7.3 Proposal Request Initiated by Intermountain.** Intermountain may file a Proposal Request with Contractor seeking information, data and/or pricing relating to a change in the Contract Time and or monies owing for particular scope changes or other modifications to the Contract Documents. The PR will provide a time limit

for Contractor to file a response with A/E and Intermountain Representative. If a proposal is not timely provided by Contractor, Intermountain may calculate the Change Order under Article 7.4.2 below. Upon such timely receipt of the proposal, one of the following will occur:

- 7.3.1 If Agreement, Change Order Issued. Intermountain Representative, after considering any input by A/E, may reach an agreement with Contractor and issue a Change Order.
- 7.3.2 If Disagreement. If Intermountain Representative disagrees with Contractor's proposal, after considering any input from A/E, Intermountain representative may seek additional information or verification from Contractor or other sources, may negotiate with Contractor, may issue a Change Order upon such later agreement, may retract the PR, or may issue a Construction Change Directive. If a Construction Change Directive is issued which identifies Intermountain representative's position in regard to the subject contract sum and/or time adjustment, Contractor must initiate the Claim resolution process provided for herein within twenty-one (21) Days of Contractor's receipt of the Construction Change Directive, or Contractor will be deemed to waive any such request for additional time or money as a result of the issuance of the Construction Change Directive. Such waiver will entitle Intermountain to convert the Construction Change Directive into a Change Order, whether or not executed by Contractor. If the Construction Change Directive leaves open the determination of additional time or money related to the directed change, then the time period for initiating the Claim resolution process will not accrue until such time as Intermountain has conveyed to Contractor a position as to the time and money owing as a result of the directed change.

#### **7.4 Evaluation of Proposal for Issuing Change Orders.**

- 7.4.1 Adjusting Sum Based Upon Agreement. If the Change Order provides for an adjustment to the Contract Sum, the adjustment will be based on the mutual agreement of Contractor and Intermountain, including any terms mandated by unit price agreements or other terms of the Contract Documents.
- 7.4.2 Intermountain Resolution of Sum and Standards in the Absence of an Agreement Under Paragraph 7.4.1. In the absence of an agreement under Paragraph 7.4.1 above, the adjustment will be based on an itemized accounting of costs and savings supported by appropriate data. Unless otherwise provided in the Contract Documents, costs for the purposes of this Paragraph will be limited to the following:
  - a. All direct and indirect costs of labor; including workers compensation insurance, social security and other federal and state payroll based taxes, and payroll based fringe benefits paid by Contractor so long as they are reasonable and no higher than that charged to other clients;
  - b. Costs of materials, on-site temporary facilities, supplies and equipment (except hand tools) required for or incorporated into the work;
  - c. Rental costs of machinery, equipment, tools (except hand tools), and on-site temporary facilities, whether rented from Contractor or others;
  - d. Costs of permits and other fees, sales, use or similar taxes related to the Work (with no markup);
  - e. Additional costs of field supervision and field office personnel directly attributable to the change; and
  - f. Overhead and profit by the markup limits in the Agreement for additional services or modifications which is not a penalty but a reasonable calculation agreed upon at the time of execution of the Agreement, and provided therein due to the fact that the actual amount due for this overhead and profit cannot easily be ascertained at the time of such execution. The markups set forth in the Agreement are to cover additional payment and performance bond premiums, insurance premiums, home office and on-site overhead and profit. Overhead and profit includes, but is not limited to Contractor's Project Manager and Cost Estimator. Each request for pricing will stand on its own and not be combined with other requests for pricing in determining the

allowed markup. A particular request for pricing will include all items reasonably related together and determinable at the time of the request. If several unrelated requests for pricing are grouped together in a single Change Order, each request for pricing will be considered separately for purposes of calculating the markup.

- 7.4.3 Credits. The amount of credit to be allowed by Contractor to Intermountain for a deletion or change which results in a net decrease in the Contract Sum will be actual net cost as confirmed to Intermountain based upon corroboration by an appropriate source.

## **7.5 Construction Change Directives.**

- 7.5.1 When Used and Contractor's Right to Challenge. A Construction Change Directive may be issued by Intermountain Representative in the case of a need for the Work to commence. If the Construction Change Directive leaves open the determination of additional time or money related to the directed change, then the Construction Change Directive will indicate the timeframe(s) in which further information is to be provided to resolve the matter. At any time that Intermountain and Contractor agree upon the time and money related to a Construction Change Directive, a Change Order will be executed by the parties. Additionally, the Construction Change Directive may be converted to a Change Order under Paragraph 7.2.2 or Article 7.3 above.
- 7.5.2 Proceed with Work and Notify Intermountain about Adjustment Method. Upon receipt of a Construction Change Directive, Contractor will promptly proceed with the change in the Work involved.
- 7.5.3 Interim Payments by Intermountain. Pending the final determination of the total cost of the Construction Change Directive, Intermountain will pay any undisputed amount to Contractor.

**7.6 A/E's Supplemental Instruction (Commonly referred to as an "ASI")**. A/E may at any time that is consistent with maintaining the quality, safety, time, budget and function of the Work, issue to Contractor a supplemental instruction ("ASI") after approval from Intermountain Representative is obtained. Contractor must file with Intermountain Representative a PCO under Paragraph 7.2.2 above, within twenty-one (21) Days of Contractor's receipt of the ASI, or the Contractor will be deemed to have waived any right to additional time or monies as a result of such ASI.

**7.7 Resolution of Disputes**. If a dispute arises between the Parties regarding the Contract Documents which is not resolved by agreement between the parties, before a party may proceed with judicial action, the dispute must be submitted in writing to Intermountain's Vice President of Financial Strategy, Growth and Development, at 36 South State Street, Salt Lake City, Utah 84111. Upon receipt of such written submission, Intermountain will schedule within seven (7) Days an initial conference or meeting, and if necessary within an additional ten (10) Days thereafter a further conference or meeting, as set forth in the escalation process herein below.

- 7.7.1 Escalation Process. The Parties will arrange in-person meetings or telephone conferences at mutually convenient times and places, according to the levels and time schedules set forth below. The Parties will use reasonable and good faith efforts in this escalation process to respond promptly and to resolve the dispute. Such meetings or conferences will constitute settlement negotiations and any settlement proposal made pursuant to such meetings or conferences will not be admissible as evidence of liability.

Levels and Representatives

Allotted Time Period from Notice  
or from Previous Level

Level 1

Contractor's Director level employee,  
and Intermountain's Director

7 Days

Level 2

Vice President or higher level executive

10 Days

7.7.2 Judicial Action. In the event that the parties do not resolve their dispute pursuant to the escalation process, either party may commence legal action to resolve the dispute. Any such action must be commenced within six (6) months from the first day of the initial Level 1 conference/meeting or be time barred. Submission of the dispute under the escalation process as outlined above is a condition precedent to the right to commence legal action to resolve any dispute. In the event that either party commences legal action to adjudicate any dispute without first submitting the dispute under the escalation process, the other party will be entitled to obtain an order dismissing the litigation without prejudice and awarding such other party any costs and attorney fees incurred by that party in obtaining the dismissal, including without limitation copy costs, and expert and consultant fees and expenses. Any such legal action must be brought exclusively in the state courts of the State of Utah or in the federal courts of the United States which are located in Salt Lake County, Utah. The Parties hereto hereby agree to submit to the exclusive jurisdiction and venue of such courts for the purposes hereof.

7.7.3 Continuation of Performance During Proceedings. Pending final resolution of a dispute hereunder, Contractor will proceed diligently with the performance of its obligations under the Contract Documents.

**7.8 Payment of Claim.**

7.8.1 When a standalone component of a Claim has received a final determination, and is no longer subject to review or appeal, that amount will be paid in accordance with the payment provisions of the Contract Documents or judicial order.

7.8.2 When the entire Claim has received a final determination, and is no longer subject to review or appeal, the full amount will be paid within thirty-one (31) Days of the date of the final determination unless the work or services has not been completed, in which case the amount will be paid in accordance with the payment provisions of the Contract Documents to the point that the work or services is completed.

7.8.3 The final determination date is the earlier of the date upon which the claimant accepted the settlement in writing with an executed customary release document and waived its rights of appeal, or the expiration of the appeal period, with no appeal filed, or the determination made resulting from the final appeal.

7.8.4 Any final determination where Intermountain is to pay additional monies to Contractor will not be delayed by any appeal or request for judicial review by another party brought into the process by Intermountain as being liable to Intermountain.

7.8.5 Notwithstanding any other provision of the Contract Documents, payment of all or part of a Claim is subject to any set-off, claims or counterclaims of Intermountain.

7.8.6 Payment to Contractor for a Subcontractor issue (Claim) deemed filed by Contractor, will be paid by Contractor to the Subcontractor in accordance with the contract between Contractor and the Subcontractor.



- 7.8.7 The execution of a customary release document related to any payment may be required as a condition of making the payment.

**7.9 Allocation of Costs of Claim Resolution Process.**

- 7.9.1 Except for attorneys' fees and expert fees, and unless otherwise agreed to by the parties to the Claim, the costs of resolving the Claim will be allocated among the parties on the same proportionate basis as the determination of financial responsibility for the Claim. The costs of resolving the Claim that are subject to allocation include the claimant's filing fee, the costs of any person(s) evaluating the Claim, the costs of making any required record of the process, and any additional testing or inspection procured to investigate and/or evaluate the Claim.
- 7.9.2 The prevailing party in any Claim, judicial action or other proceeding is entitled to recover its reasonable attorneys' fees, expert and other fees, and costs incurred in the proceeding, in addition to any other relief to which that party may be entitled.

**7.10 Alternative Procedures.** To the extent otherwise permitted by law, if all parties to a Claim agree in writing, a protocol for resolving a Claim may be used that differs from the process described in this Article 7.

**8. PAYMENTS AND COMPLETION.**

**8.1 Schedule of Values.** With the first Application for Payment, Contractor will submit to A/E and Intermountain Representative a schedule of values allocated to all the various portions of the Work. The Schedule of Values will be submitted on the form approved and provided by Intermountain. A/E will make recommendations to Intermountain Representative regarding the Schedule of Values including any suggested modifications. When approved, including any approved modifications, by Intermountain Representative, it will be the basis for future Contractor Applications for Payments. Contractor will not be entitled to payment until receipt and acceptance of the Schedule of Values.

**8.2 Applications for Payment.**

- 8.2.1 In General. The following general requirements will be met:
- a. Not more than once a month, Contractor will submit to A/E an itemized Application for Payment for Work completed in accordance with the schedule of values and that reflects retainage as provided for in the Contractor's Agreement. Contractor's Applications for Payment will include conditional or final lien waivers (as applicable), in the forms attached to Contractor's Agreement for itself and from each Subcontractor requesting payment, covering all payments requested in the Application for Payment. The Application for Payment will be on a form provided by Intermountain.
  - b. Such application will be supported by such data substantiating Contractor's right to payment as Intermountain or A/E may require. This data may include, but is not limited to, copies of requisitions from Subcontractors.
  - c. Such applications may include requests for payment pursuant to approved Change Orders or Construction Change Directives.
  - d. Such applications may not include requests for payment for portions of the Work performed by a Subcontractor when Contractor does not intend to pay to a Subcontractor because of a dispute or other reason.
  - e. In executing the Application for Payment, Contractor will attest that Subcontractors involved with prior applications for payment have been paid, unless Contractor provides a detailed explanation why such payment may not have occurred. Intermountain reserves the right to require Contractor to submit a payment waiver from one or more Subcontractors.
- 8.2.2 Payment for Material and Equipment. Unless otherwise provided in the Contract Documents, payments will be made on account of materials and equipment delivered and suitably stored at the

site for subsequent incorporation in the Work. If approved in advance by Intermountain and A/E, payment may similarly be made for materials and equipment suitably stored off the site at a location agreed upon in writing. Payment for materials and equipment stored on or off the site will be conditioned upon compliance by Contractor with procedures satisfactory to Intermountain to establish Intermountain's title to such materials and equipment or otherwise protect Intermountain's interest, and will include applicable insurance, storage and transportation to the site for such materials and equipment stored on or off the site. Intermountain may require copies of invoices or other suitable documentation.

8.2.3 Warranty of Title. Contractor warrants that title to all Work covered by an Application for Payment will pass to Intermountain no later than the time for payment. Contractor further warrants that upon submittal of an Application for Payment, all Work for which Certificates for Payment have been previously issued and payments received from Intermountain will, to the best of Contractor's knowledge, information and belief, be free and clear of liens, claims, security interests or encumbrances in favor of Contractor, Subcontractors, or other persons or entities making a claim by reason of having provided labor, materials and/or equipment relating to the Work.

8.2.4 Retainage and Holdback by Intermountain.

- a. *Holdback by Intermountain.* Notwithstanding anything to the contrary contained in the Contract Documents, Intermountain may, as a result of the Claim resolution process, withhold any payment to Contractor hereunder if and for so long as Contractor fails to perform any of its obligations hereunder or otherwise is in default under any of the Contract Documents.
- b. *Intermountain's Right to Withhold and Use Funds.* Intermountain may withhold from payment to Contractor such amount as, in Intermountain's judgment, may be necessary to pay just claims against Contractor or Subcontractors at any tier for labor and services rendered and materials furnished in and about the Work. Intermountain may apply such withheld amounts for the payment of such claims in Intermountain's discretion. In so doing, Intermountain will be deemed the agent of Contractor and payment so made by Intermountain will be considered as payment made under the Contract by Intermountain to Contractor. Intermountain will not be liable to Contractor for any such payment properly made. Such withholdings and payments may be made without prior approval of Contractor and may also be made before any determination as a result of any dispute, Claim or litigation. However, Contractor will be notified before any such withholding and will be given an opportunity to inform Intermountain as to any reason why the withholding will not occur.
- c. *Statutory Retainage.* Notwithstanding and in addition, retainage in the amount of 5% will be withheld from each payment to Contractor for any Work under the Contract. The retainage, including any additional retainage imposed and the release of any retainage, will be in accordance with Intermountain policies, including restrictions of retainage regarding Subcontractors and the distribution of interest earned on the retention proceeds. After Contractor achieves Substantial Completion and submits its payment request for retained funds and provides statutory Conditional Waiver and Release documents executed by all subcontractors and suppliers having claim against the retained funds, Intermountain will pay any unpaid statutory retention, less any offsets or withholdings for specific deficiencies or disputes, within forty-five (45) Days. Notwithstanding the foregoing, Intermountain may (but is not obligated to), in its sole discretion, release from time to time any portion of retention funds for early completing subcontractors and/or otherwise reduce the overall retention funds withheld.
- d. *Intermountain Not Responsible for Contractor's Retention Requirements.* Intermountain will not be responsible for enforcing Contractor's obligations under Utah law in fulfilling the retention law requirements with Subcontractors at any tier.

8.2.5 Reimbursement to Intermountain. Notwithstanding any other provision of the Contract, Contractor will reimburse Intermountain for the portion of any expenses paid by Intermountain to Contractor,

which is attributable to Contractor's breach of its duties under the Contract, including the breach of any duty by any Subcontractor or supplier at any tier or anyone for whom Contractor may be liable.

### **8.3 Certificates for Payment.**

- 8.3.1 Issued by A/E. A/E will within ten (10) Days after receipt of Contractor's Application for Payment, either issue to Intermountain a Certificate for Payment, with a copy to Contractor, for such amount as A/E determines due, or notify Contractor and Intermountain in writing of A/E's reasons for withholding certification in whole or in part as provided in Paragraph 8.4.1. If A/E fails to act within this ten (10) Day period, Contractor may file the Application for Payment directly with Intermountain Representative and Intermountain will thereafter have thirty-one (31) Days from the date of Intermountain's receipt to resolve the amount to be paid and to pay the undisputed amount. The accuracy of Contractor's Applications for Payment will be Contractor's responsibility, not A/E's.
- 8.3.2 A/E's Representations. A/E's issuance of a Certificate for Payment will constitute a representation to Intermountain that to the best of A/E's knowledge, information and belief, based upon A/E's observations at the site, the data comprising the Application for Payment, and what is reasonably inferable from the observations and data, that the Work has progressed to the point indicated in the Application for Payment and that the quality of the work is in accordance with the Contract Documents. The foregoing representations are subject to minor deviations from the Contract Documents correctable before completion and to specific qualifications expressed by A/E. The issuance of a Certificate for Payment will further constitute a representation that Contractor is entitled to payment in the amount certified. However, the issuance of a Certificate for Payment will not be a representation that A/E has (a) made exhaustive or continuous on-site inspections to check the quality or quantity of the Work, (b) reviewed construction means, methods, techniques, sequences or procedures, (c) reviewed copies of requisitions received from Subcontractors and material suppliers and other data requested by Intermountain to substantiate Contractor's right to payment, (d) ascertained how or for what purpose Contractor used money previously paid on account of Contract Sum, or (e) any duty to make such inquiries.
- 8.3.3 Contractor Respond to Financial Responsibility and Related Requests, Waivers, Releases, Bonds. Contractor will respond immediately to any inquiry in writing by Intermountain as to any concern of financial responsibility and Intermountain reserves the right to request any waivers, releases or bonds from Contractor in regard to any rights of Subcontractors (including suppliers) at any tier or any third-party before any payment by Intermountain to Contractor.

### **8.4 Decisions to Withhold Certification.**

- 8.4.1 When Withheld. A/E may decide not to certify payment and may withhold a Certificate for Payment in whole or in part, to the extent reasonably necessary to protect Intermountain, if in A/E's judgment the representations to Intermountain required in Paragraph 8.3.2 above cannot be made. If A/E is unable to certify payment in the amount of the Application, A/E will notify Contractor and Intermountain as provided in Paragraph above. If Contractor and A/E cannot agree on a revised amount, A/E will promptly issue a Certificate for Payment for the amount to which A/E makes such representations to Intermountain. A/E may also decide not to certify payment or, because of subsequently discovered evidence or observations, may nullify the whole or part of a Certificate for Payment previously issued, to such extent as may be necessary in A/E's opinion to protect Intermountain from loss because of:
- a. Defective Work not remedied;
  - b. Third party claims filed or reasonable evidence indicating probable filing of such claims;
  - c. Failure of Contractor to make payments properly to Subcontractors or for labor, materials or equipment;
  - d. Reasonable evidence that the Work cannot be completed for the unpaid balance of the Contract Sum;

- e. Damage to Intermountain or another contractor;
  - f. Reasonable evidence that the Work will not be completed within the Contract Time, and that the unpaid balance would not be adequate to cover actual or liquidated damages for the anticipated delay; or
  - g. Failure to carry out the Work in accordance with the Contract Documents.
- 8.4.2 Certification Issued When Reasons for Withholding Removed. When the reasons stated in Paragraph 8.4.1 for withholding certification are removed, certification will be made for such related amounts.
- 8.4.3 Continue Work Even If Contractor Disputes A/E's Determination. If Contractor disputes any determination by A/E or the result of the Claim resolution process with regard to any Certification of Payment, Contractor nevertheless will expeditiously continue to prosecute the Work.
- 8.4.4 Intermountain Not in Breach. Intermountain will not be deemed to be in breach of this Contract by reason of the withholding of any payment pursuant to any provision of the Contract Documents provided Intermountain's action or such withholding is consistent with the results of the dispute resolution process.

## **8.5 Progress Payments.**

- 8.5.1 In General, Interest on Late Payments.
- a. Except as provided in Paragraph 8.3.1, Intermountain will pay any undisputed amount within thirty-one (31) Days of satisfaction of the following requirements: (i) Contractor has submitted the application for payment; (ii) A/E has issued to Intermountain a Certificate recommending payment; (iii) Contractor has obtained conditional or unconditional waiver and release documents executed by all of Subcontractors performing work and/or providing materials covered by the Contractor's payment request; and (iv) Contractor has provided all "as-built" drawings to A/E sufficient for A/E to compile and provide a final set of Record Drawings for each completed phase and for all portions of the Project for which a certificate of occupancy is issued. In no event will Intermountain be required to pay any disputed amount.
  - b. Except as otherwise provided by law, if any payment is made more than sixty (60) Days after receipt by Intermountain of the applicable invoice (with any required supporting documentation), the late payment will bear interest from the due date until payment is made at the rate of five percent (5%) per annum.
- 8.5.2 Contractor and Subcontractor Responsibility. Contractor will promptly pay each Subcontractor, upon receipt of payment from Intermountain, out of the amount paid to Contractor on account of such Subcontractor's portion of the Work, the amount to which this Subcontractor is entitled. Contractor will, by appropriate agreement with each Subcontractor, require each Subcontractor to make payment to its Subcontractors in a similar manner.
- 8.5.3 Information Furnished by A/E Or Intermountain to Subcontractor. A/E or Intermountain will, on request, furnish to the Subcontractor, if practicable, information regarding percentages of completion or amounts applied for by Contractor and action taken thereon by A/E and Intermountain on account of portions of the Work done by such Subcontractor.
- 8.5.4 Intermountain and A/E Not Liable. Neither Intermountain nor A/E will have an obligation to pay, monitor or enforce the payment of money to a Subcontractor, except to the extent as may otherwise be required by law.
- 8.5.5 Certificate, Payment or Use Not Acceptance of Improper Work. A Certificate for Payment, a progress payment, or partial or entire use or occupancy of the Project by Intermountain will not constitute acceptance of Work that is not in accordance with the Contract Documents.

**8.6 Payment upon Substantial Completion.** Upon Substantial Completion of the Work or designated portion thereof and upon application by Contractor and certification by A/E, Intermountain will make payment, reflecting adjustment in retainage, if any, for such Work or portion thereof as provided in the Contract Documents. To the extent allowed by law, Intermountain may retain up to 200% of the fair market value of the work that has not been completed in accordance with the Contract Documents.

**8.7 Partial Occupancy or Use.**

8.7.1 In General. Intermountain may occupy or use any completed or partially completed portion of the Work at any stage when such portion is designated by separate agreement with Contractor, and authorized by public authorities having jurisdiction over the Work. Such partial occupancy or use may commence whether or not the portion is Substantially Complete, provided Intermountain and Contractor have accepted in writing the responsibilities assigned to each of them for payments, retainage if any, security, maintenance, heat, utilities, damage to the Work and insurance, and have agreed in writing concerning the period for correction of the Work and commencement of the warranties required by the Contract Documents. When Contractor considers a portion to be substantially complete, Contractor will prepare and submit a list to A/E as previously provided for herein. Consent of Contractor to partial occupancy or use will not be unreasonably withheld. Contractor will have continuing responsibility to protect the unoccupied portions of the site and the Work during such partial occupancy and will be responsible for damage except to the extent caused solely by Intermountain during such partial occupancy or use.

The stage of progress of the Work will be determined by written agreement between Intermountain and Contractor.

8.7.2 Inspection. Immediately before such partial occupancy or use, Intermountain, Contractor and A/E will jointly inspect the area to be occupied or portion of the Work to be used in order to determine and record the condition of the Work.

8.7.3 Record Drawings. Contractor will provide all “as-built” drawings to A/E and A/E will then provide to Intermountain within forty-five (45) Days of any partial occupancy a final set of Record Drawings for the occupied phase or portion of the Project.

8.7.4 Not Constitute Acceptance. Except to the extent it is agreed upon in writing by Intermountain, partial occupancy or use of a portion or portion of the Work will not constitute acceptance of Work not complying with the requirement of the Contract Documents.

**8.8 Final Payment.**

8.8.1 Certificate for Payment. A/E’s final Certificate for Payment will constitute a further representation that the conditions listed in Paragraph 8.8.2 as precedent to Contractor’s being entitled to final payment have been fulfilled.

8.8.2 Conditions for Final Payment. Neither final payment nor any remaining retained percentage will become due until Contractor submits to A/E the following to the extent required by Intermountain Representative:

- a. A final payment request;
- b. Waiver and release upon final payment documents executed by all of the Subcontractors performing work and/or providing materials covered by the Contractor’s final payment request;
- c. An executed Substantial Completion form, which includes remaining Project items to be completed, Final Certificate of Occupancy from the applicable municipality, fire clearance(s) from Fire Marshal, Approval(s) from applicable State Dept. of Health, and any other permits/approvals for occupancy of Project as required by authorities with jurisdiction over the Project;
- d. Evidence satisfactory to Intermountain that all required utilities are installed, commissioned, and operating consistent with the Specifications;

- e. Confirmation of completion of any review or, if applicable, audit of Contractor's Payment Applications and reconciliation, as required by Intermountain;
- f. All manufacturers' and other guaranties and warranties, properly signed and endorsed to Intermountain, that are required by the Contract Documents that extend for a period beyond one year after substantial completion. (Delivery of such guaranties and warranties will not relieve Contractor for any obligation assumed under any other provision of the Contract Documents.);
- g. An affidavit that payrolls, bills for material and equipment, and other indebtedness connected with the Work for which Intermountain's property might be responsible or encumbered (less amounts withheld by Intermountain) have been paid or otherwise satisfied;
- h. A current or additional certificate evidencing that insurance required by the Contract Documents to remain in force after final payment is currently in effect and will not be canceled or allowed to expire until at least thirty (30) Days prior written notice, by certified mail, return receipt requested, has been given to Intermountain;
- i. A written statement that Contractor knows of no substantial reason that the insurance will not be renewable to cover the period required by the Contract Documents;
- j. If requested by surety in a timely manner or by Intermountain, consent of surety, to final payment;
- k. Up to date "as-built" Drawings certified by Contractor as accurate and complete, Specifications, Addenda, Change Orders and other Modifications maintained at the site; the warranties, instructions, operation and maintenance manuals, and training videos required to be furnished by the Contract Documents;
- l. Other data establishing payment or satisfaction of obligations, such as receipts, releases and waivers of liens, claims, security interests or encumbrances arising out of the Contract, to the extent and in such form as may be designated by Intermountain. If a Subcontractor refuses to furnish a release or waiver required by Intermountain, Intermountain may require consent of surety to the final payment. If such liens, claims, security interests or encumbrances remain unsatisfied after payments are made, Contractor will refund to Intermountain all money that Intermountain may be compelled to pay in discharging such lien, including all costs and reasonable attorneys' fees; and
- m. A written statement demonstrating how Contractor will distribute interest earned on retention to Subcontractors as required by Section 13.8.5, U.C.A.

In addition, A/E must declare to Intermountain in writing that the Work is complete and provide a final set of Record Drawings. If the aggregate of previous payments made by Intermountain exceeds the amount due Contractor, Contractor will reimburse the difference to Intermountain within ten (10) Days of Intermountain's request.

- 8.8.3 Waiver of Claims: Final Payment. The making of final payment will not constitute a waiver of Claims or other rights by Intermountain.
- 8.8.4 Waiver by Accepting Final Payment. Acceptance of final payment by Contractor or a Subcontractor will constitute a waiver of Claims by that payee except those Claims previously made in writing and identified by that payee as unsettled at the time of final Application for Payment.
- 8.8.5 Time of Repose and Waiver. In addition and notwithstanding, claims and invoices for work, equipment, services, or materials that are not submitted to Intermountain within one (1) year of Substantial Completion of the Project are completely void and unenforceable as against Intermountain. Contractor and all Subcontractors hereby waive all rights and claims against Intermountain attendant such claims and invoices, and Contractor will contractually obligate each Subcontractor to waive all rights and claims against Intermountain attendant such claims and

invoices. This provision imposes an absolute cut off on the timing for submitting such claims and invoices; this provision does not lengthen any timing requirements in the Contract Documents.

## **9. TESTS AND INSPECTIONS, SUBSTANTIAL AND FINAL COMPLETION, UNCOVERING, CORRECTION OF WORK, AND GUARANTY PERIOD.**

### **9.1 Tests and Inspections.**

- 9.1.1 In General. Tests, inspections and approvals of portions of the Work required by the Contract Documents or by laws, ordinances, rules, regulations, resolutions or orders of public authorities having jurisdiction will be made at an appropriate time. Unless otherwise specifically set forth in the Contract Documents or agreed to by Intermountain in writing, Intermountain will contract for such tests, inspections and approvals with an independent entity, or with the appropriate public authority, and Intermountain will bear all related costs of tests, inspections and approvals except as provided below. If any of the Work is required to be inspected or approved by the terms of the Contract Documents or by any public authority, Contractor will, at least two working days before the time of the desired inspection, and following the procedures established by Intermountain, request such inspection or approval to be performed. Contractor will give A/E timely notice of when and where tests and inspections are to be made so that A/E may observe such procedures.
- 9.1.2 Failure of An Inspector to Appear. Work will not proceed without any required inspection and the associated authorization by Intermountain to proceed unless the following procedures and requirements have been met:
- a. The inspection or approval was requested in a timely manner as provided in Paragraph 9.1.1;
  - b. Contractor received written confirmation from the inspection entity that the inspection was scheduled;
  - c. Contractor has contacted or attempted to contact the inspector to confirm that the inspector is unable to perform the inspection as scheduled;
  - d. If the inspector has confirmed that it is unable to perform the inspection as scheduled or if Contractor is unable to contact the inspector, Contractor will attempt to contact Intermountain Representative for instruction; and Contractor has documented the condition of the work before being covered through photos or other means.
- 9.1.3 Nonconforming Work. If such procedures for testing, inspection or approval under Paragraph 9.1.1 reveal failure of portions of the Work to comply with the requirements established by the Contract Documents, Contractor will bear all costs made necessary by such failure including those of repeated procedures and compensation for Intermountain's expenses, including the cost of retesting for verification of compliance if necessary, until Intermountain accepts the Work in question as complying with the requirements of the Contract Documents.
- 9.1.4 Certificates. Required certificates of testing, inspection or approval will, unless otherwise required by the Contract Documents, be secured by Contractor and promptly delivered to A/E.
- 9.1.5 A/E Observing. If A/E is to observe tests, inspections or approvals required by the Contract Documents, A/E will do so with reasonable promptness and, where practicable, at the normal place of testing.
- 9.1.6 Promptness. Tests, inspections and arrangements for approvals conducted pursuant to the Contract Documents will be made promptly to avoid unreasonable delay in the Work.

### **9.2 Inspections: Substantial and Final.**

- 9.2.1 Substantial Completion Inspection. Before requesting a substantial completion inspection, Contractor will prepare a comprehensive initial punchlist, including unresolved items from prior inspections, for review by Intermountain and A/E to determine if the Project is ready for a substantial completion inspection. If Intermountain determines that the initial punchlist indicates that the Project is not

substantially complete, the initial punchlist will be returned to Contractor with written comments. If Intermountain determines that the initial punchlist indicates that the Project may be substantially complete, A/E will promptly organize and perform a Substantial Completion inspection in the presence of Intermountain and all appropriate authorities.

- a. If A/E reasonably determines that the initial punchlist prepared by Contractor substantially understates the amount of the Work remaining to be completed and the Project is not substantially complete, A/E will report this promptly to Intermountain, and upon concurrence of Intermountain, Contractor will be assessed the costs of the inspection and punchlist preparation incurred by A/E and Intermountain.
- b. When the Work or designated portion thereof is Substantially Complete, A/E will prepare a Certificate of Substantial Completion which will establish the date of Substantial Completion; will establish responsibilities of Intermountain and Contractor for security, maintenance, heat, utilities, damage to the work and insurance; and will fix the time within which Contractor will finish all items on the punchlist accompanying the Certificate. The Certificate of Substantial Completion will require approval by Intermountain Representative. If there is a punchlist, Contractor will proceed promptly to complete and correct items on the list. Failure to include an item on the punchlist does not alter the responsibility of Contractor to complete all Work in accordance with the Contract Documents.
- c. Warranties required by the Contract Documents will commence on the date of Substantial Completion of the Work or designated portion thereof except to the extent as provided otherwise in the Contract Documents or if such warranty is related to an item where the work is not complete. Such warranty documents will state the length of the warranty, which must comply with the Contract Documents.
- d. The Certificate of Substantial Completion will be submitted by A/E to Intermountain and Contractor for their written acceptance of responsibilities assigned to them in such Certificate.
- e. Except to the extent Intermountain Representative otherwise approves in advance and in writing, Contractor will submit the following documents in order to achieve Substantial Completion: written warranties, guarantees, operation and maintenance manuals, and all complete "as-built" Drawings. Contractor must also provide or obtain any required approvals for occupancy, and deliver "as-built" drawings to A/E sufficient to enable A/E to compile and provide a final set of Record Drawings for each completed phase and for each area for which a certificate of occupancy is issued within forty-five (45) Days of such issuance. Contractor is responsible for the guaranty of all Work, whether performed by it or by its Subcontractors at any tier.

9.2.2 Final Completion Inspection. Before requesting a final inspection, Contractor will verify all punchlist items are corrected/completed. Once all punchlist items are corrected/completed Contractor will notify Intermountain and request a final inspection. Intermountain will notify A/E and perform a final inspection. Two final inspections may be allowed due to required weather changes required to complete some items. When all punchlist items are completed a final pay request will be provided by Contractor, authorized by A/E and processed by Intermountain.

### **9.3 Uncovering of Work.**

- 9.3.1 Uncover Uninspected Work. Except as provided in Paragraph 9.3.3, if a portion of the Work is covered before an Inspector's approval to proceed, it must, be uncovered for the Inspector's inspection and be replaced at Contractor's expense without change in the Contract Time.
- 9.3.2 Observation before Covering. Except as provided in Paragraph 9.3.3, if Intermountain or A/E has requested in writing to observe conditions before any Work being covered or if such observation is specified in the Contract Documents, and the Work is covered without such observation, Contractor will be required to uncover and appropriately replace the Work at Contractor's expense without change in the Contract Time. If Contractor requests an inspection and Intermountain or A/E, including



any inspector of each, does not appear, Contractor will immediately notify Intermountain of such lack of appearance, but will not cover the Work without such inspection.

- 9.3.3 When an Inspector Fails to Appear Or A/E Or Intermountain Did Not Make Prior Request. If Work is performed by Contractor without an inspection as provided in Paragraph 9.1.2 or if a portion of the Work has been covered which A/E or Intermountain has not specifically requested to observe before its being covered or such observation is not specified by the Contract Documents, A/E or Intermountain may request to see such Work and it will be uncovered by Contractor. If such Work is in accordance with the Contract Documents, costs of uncovering and replacement, will, by appropriate Change Order, be charged to Intermountain. If such Work is not in accordance with the Contract Documents, Contractor will pay such costs unless the condition was caused by Intermountain or a separate contractor in which event Intermountain will be responsible for payment of such costs.

#### **9.4 Correction of Work and Guaranty Period.**

- 9.4.1 Contractor Correct the Work. Contractor will correct Work rejected by A/E, Inspector or Intermountain, or failing to conform to the requirements of the Contract Documents, whether observed before or after Substantial Completion and whether or not fabricated, installed or completed. Contractor will bear the costs of correcting such rejected Work, including additional testing and inspections and compensation for A/E's and Inspector's services and expenses made necessary thereby.
- 9.4.2 Guaranty and Correction after Substantial Completion. If within one year after the date of Substantial Completion of the Work or designated portion thereof, or after the date for commencement of warranties established under Paragraph 9.2.1 or by terms of an applicable special warranty or guaranty required by the Contract Documents, any of the Work is found to be not in accordance with the requirements of the Contract Documents, including failure to perform for its intended purpose, Contractor will correct it promptly after receipt of written notice from Intermountain to do so unless Intermountain has previously given Contractor a written acceptance of such condition. The period of one year will be extended with respect to portions of the Work first performed after Substantial Completion by the period of time between Substantial Completion and the actual performance of the Work. This obligation of Contractor under this Paragraph 9.4.2 will be operative notwithstanding the acceptance of the Work under the Contract, the final certificate of payment, partial or total occupancy and/or termination of the Contract. Intermountain will give notice of observed defects with reasonable promptness, however, failure to give such notice will not relieve Contractor of its obligation to correct the Work at the cost that Contractor would have incurred if Intermountain did so report with reasonable promptness. All corrected Work will be subject to a one-year guaranty period the same in all respects as the original Work, except that such guaranty period will commence from the time of Substantial Completion of the corrected Work. This guaranty period does not affect Intermountain's right to pursue any available remedies against Contractor.
- 9.4.3 Removal of Work.
- a. Contractor will promptly remove from the premises all Work that Intermountain and/or A/E determines as being in nonconformance with the Contract Documents, whether incorporated or not.
  - b. Contractor will promptly replace and re-execute the Work in accordance with the Contract Documents and without expense to Intermountain.
  - c. Contractor will bear the expense of correcting destroyed or damaged construction, whether completed or partially completed, of Intermountain or of other contractors destroyed or damaged by such removal or replacement.

- d. If Contractor does not remove such rejected Work within a reasonable time, fixed by written notice, Intermountain may have the materials removed and stored at the expense of Contractor.
- e. If Contractor does not correct the nonconforming Work within a reasonable time, fixed by written notice, Intermountain may correct it in accordance with Paragraph 12.2.2 of these General Conditions.

9.4.4 Not Limit Other Obligations. Nothing contained in this Article 9.4 will be construed to establish a period of limitation with respect to other obligations which Contractor may have under the Contract Documents. Establishment of the time period of one year as described in Paragraph 9.4.2 relates only to the specific obligation of Contractor to correct the Work, and has no relationship to the time within which the obligation to comply with the Contract Documents may be sought to be enforced, nor to the time within which proceedings may be commenced to establish Contractor's liability with respect to Contractor's obligations other than specifically to correct the Work.

## 9.5 Additional Warranties.

9.5.1 In General. In addition to any other provisions of this Article 9, the following warranties will apply:

- a. Contractor warrants to Intermountain that materials and equipment furnished under the Contract will be of good quality and new, except to the extent otherwise required or expressly permitted by the Contract Documents.
- b. Contractor also warrants to Intermountain that the Work will be free from defects not inherent in the quality required or permitted and that the Work will conform to the requirements of the Contract Documents. Work not conforming to these requirements, including substitutions not properly approved and authorized, may be considered Defective at Intermountain's option.

9.5.2 Correction of Work.

- a. Contractor will promptly correct any portion of the Work which is rejected by A/E, the inspector, or Intermountain, or which fails to conform to the requirements of the Contract Documents, whether observed before or after Substantial Completion and whether or not fabricated, installed, or completed. Contractor will bear the cost of correcting such rejected Work, including additional testing and inspection costs, compensation for A/E's services, and any other expenses made necessary thereby. Such costs will in no way be payable by Intermountain and will not increase the Contract Sum.
- b. Contractor will remedy any Defects due to faulty materials, equipment, or workmanship which appear within a period of one (1) year from the date of Substantial Completion or within such longer period of time as may be prescribed by law or by the terms of any applicable special warranty required by the Contract Documents. Contractor will pay all costs of correcting faulty work, including additional A/E fees, attorney fees, expert fees, consultant fees, copy costs, and other expenses when incurred. Such costs will in no way be payable by Intermountain and will not increase the Contract Sum.
- c. Nothing in the Contract Documents will be construed to establish a period of limitation within which Intermountain may enforce the obligation of Contractor to comply with the Contract Documents. The one (1) year period specified in paragraph 9.5.2(2) has no relationship to the time within which Intermountain may enforce compliance with the Contract Documents, nor to the time within which proceedings may be commenced to establish Contractor's liability with respect to Contractor's obligations.

9.5.3 Exclusion. Unless due to the negligent or intentional act or omission of Contractor or those under Contractor's control, or as otherwise stated in the Contract Documents, Contractor's guaranty excludes remedy for damage or defect caused by abuse, modifications not executed by Contractor, improper or insufficient maintenance, improper operation, or normal wear and tear under normal usage.

9.5.4 Furnish Evidence on Request. If requested by A/E or Intermountain, Contractor will furnish satisfactory evidence as to the type and quality of materials and equipment.

**9.6 Acceptance of Nonconforming Work.** If Intermountain prefers to accept Work which is not in accordance with the requirements of the Contract Documents, Intermountain may do so in writing instead of requiring its removal and correction, in which case the Contract Sum will be reduced as appropriate and equitable. Such adjustment will be effected whether or not final payment has been made. Without limitation, usage by Intermountain or A/E of mechanical devices, machinery, apparatus, equipment, or other work or materials supplied under the Contract Documents before written acceptance by Intermountain, will not constitute Intermountain's acceptance.

## 10. INSURANCE AND BONDS.

**10.1 Insurance.** To protect against liability, loss and/or expense arising in connection with the performance of services described under the Contract Documents, Contractor will obtain and maintain in force as set forth below in section 10.1.9 without interruption, the following stated insurance, in a form and content satisfactory to Intermountain, from insurance companies authorized to do business in the State in which the Project is located with an A.M. Best's Rating of A- or better and Class VII or better. Contractor will require all Subcontractors to have and maintain similarly required policies. All of the following listed insurance coverages will be provided by Contractor.

10.1.1 Contractor's Commercial General Liability Insurance. Contractor will maintain coverage, with ISO Form CG 00 01 or other policy form satisfactory to Intermountain, on an occurrence basis, including coverage for Premises-Operations, Independent Contractors' Protective, Products-Completed Operations, Contractual Liability, Personal Injury, and Broad-Formed Property Damage (including coverage for Explosion, Collapse, and Underground hazards), which will provide primary coverage to the additional insureds (Intermountain and the A/E) in the event of any occurrence, claim, or suit, with per occurrence and annual aggregate policy limits of at least as follows:

\$2,000,000	General Aggregate;
\$2,000,000	Products-Completed Operations Aggregate;
\$1,000,000	Personal and Advertising Injury;
\$1,000,000	Each Occurrence.

Intermountain reserves the right to require additional coverage limits of liability from that stated above. Intermountain also reserves the right to require project specific insurance, and if such right has been exercised it will be indicated in the Contract Documents.

10.1.2 Excess and Umbrella Liability Insurance. Contractor will maintain excess and liability insurance with coverage at least as broad as the underlying liability insurance described in this section, written on an occurrence basis with per occurrence and annual aggregate policy limits based on the following chart, unless modified by mutual agreement of the parties,

Small Project (\$2,000,000 or less)
Minimum Commercial General Liability Coverage
\$1,000,000 each occurrence,
\$3,000,000 general aggregate
Medium Project (\$2,000,001 to \$10,000,000)
Minimum Commercial General Liability Coverage
\$5,000,000 each occurrence,
\$10,000,000 general aggregate
Large Project (Greater than \$10,000,000)
Minimum Commercial General Liability Coverage

\$10,000,000 each occurrence,  
\$20,000,000 general aggregate

For insurance purposes, the size of the Project will be specified in the Contractor's Agreement. Such excess or umbrella liability policy will follow form with the primary liability policies, and contain a drop-down provision in case of impairment of underlying limits.

- 10.1.3 Workers' Compensation Insurance and Employers' Liability Insurance. Worker's Compensation Insurance will cover full liability under the Worker's Compensation Laws of the jurisdiction in which the Project is located at the statutory limits required by this jurisdiction's laws. Contractor will also maintain Employer's Liability Insurance with limits of at least \$1,000,000 each accident, \$1,000,000 for bodily injury by accident, and \$1,000,000 each employee for injury by disease. Contractor will collect and keep on-file evidence that Contractor and all tiers of Subcontractors have current certificates of this Workers Compensation Insurance (as required by State statute) as well as Employer's Liability Insurance, and will produce them upon request by Intermountain.
- 10.1.4 Automobile. Automobile liability insurance for claims arising from the ownership, maintenance, or use of a motor vehicle. The insurance will be written on an "occurrence" form and will apply to "any auto" and will cover all owned, non-owned, and hired automobiles used in connection with the work, with the following minimum limits of liability: \$1,000,000 – Combined Single Limit Bodily Injury and Property Damage per Occurrence.
- 10.1.5 Pollution Liability Insurance. Pollution Liability Insurance covering Contractor's or appropriate Subcontractor's liability for bodily injury, property damage and environmental damage resulting from sudden, accidental, and gradual pollution and related cleanup costs incurred by Contractor, all arising out of the goods delivered or Work and services performed (including transportation risk) under this Contract, is required with limits of at least \$1,000,000 per claim and \$1,000,000 annual aggregate.
- 10.1.6 Aircraft Use. Contractor using its own manned or unmanned aircraft, or employing manned or unmanned aircraft in connection with the work performed under the Contract Documents will maintain Aircraft Liability Insurance with a combined single limit of not less than \$1,000,000 per occurrence. This certificate will state that the policy required by this paragraph has been endorsed to name Intermountain as an Additional Insured.
- 10.1.7 Policy Aggregate(s). Unless project specific insurance is required by Intermountain, the above insurance coverages will be written or endorsed under a policy to have general, per occurrence, and aggregate limits of liability applicable to this project only.
- 10.1.8 Certificates. Before the Contract Documents are executed, Contractor will submit certificates in form and substance satisfactory to Intermountain as evidence of the insurance requirements of this Article 10. Contractor will obtain copies of Additional Insured (Ongoing and Completed Operations), Waiver of Subrogation, and Primary and Non-Contributory Endorsements and/or policy clauses. The certificates will contain provisions that no cancellation, or non-renewal will become effective except upon thirty (30) Days prior written notice by US Mail to Intermountain as evidenced by return receipt, certified mail sent to Intermountain. Contractor will notify Intermountain within thirty (30) Days of any claim(s) against Contractor which singly or in the aggregate exceed 20% of the applicable required insured limits and Contractor will, if requested by Intermountain, use its best efforts to reinstate the policy within the original limits and at a reasonable cost. Intermountain will be named as an additional insured party, as primary coverage and not contributing, on all the insurance policies required by this Article, except the professional liability and workers' compensation policies, by endorsements satisfactory to Intermountain -- using a combination of ISO forms CG 20 10 (07/04), Additional Insured – Owners, Lessees or Contractors – Scheduled Person or Organization and CG 20 37 (07.04) Additional Insured – Owners, Lessees or Contractors – Completed Operations, or other forms acceptable to Intermountain, naming Intermountain and A/E as additional insureds. Intermountain reserves the right to request Contractor to provide a loss report from its insurance carrier. Contractor will collect and keep on-file evidence that Contractor and each Subcontractor has

current certificates of Commercial General Liability Insurance, Excess /Umbrella Liability Insurance, and other insurance required herein, and will produce them upon request by Intermountain.

- 10.1.9 Maintain throughout Contract Documents Term. Contractor will maintain, from commencement of the Work, insurance coverage required in Articles 10.1 and 10.2 as follows:
- a. Commercial General Liability Insurance through expiration of the statute of limitations/repose for completed operations, but in no event less than ten (10) years from completion of the Project; and
  - b. All other insurance through final payment.
- 10.1.10 Waivers of Subrogation. Contractor waives all rights against Intermountain and other additional insureds for recovery of damages to the extent the losses and damages are covered by existing insurance, including without limitation commercial general liability, commercial excess/umbrella liability, business auto liability, workers compensation or employer's liability insurance, and pollution liability insurance. Contractor will ensure that all insurance policies required herein will be endorsed to include waivers of subrogation in favor of Intermountain. Contractor hereby waives all rights of subrogation against Intermountain.
- 10.1.11 Excess Coverages. Any type of insurance or any increase of limits of liability not described in the Contract Documents which Contractor requires for its own protection or on account of any statute, rule or regulation, will be its own responsibility and at its own expense.
- 10.1.12 Not Relieve Contractor of Liability. The carrying of any insurance required by the Contract Documents will in no way be interpreted as relieving Contractor of any other responsibility or liability under the Contract Documents or any applicable law, statute, rule, regulation, or order.
- 10.1.13 Contractor Compliance with Policies. Contractor will not violate or permit to be violated any of the provisions of the insurance policies required under the Contract.
- 10.1.14 Deductible Liability. Any and all deductibles in the above described policies will be assumed by, for the account of, and at the sole risk of Contractor. The allowable deductible for any of the Contractor insurance policies required by these General Conditions shall be no less than \$1,000 or 0.1 percent of the Contract Amount, whichever is greater.

## **10.2 "Builder's Risk" Property Insurance.**

- 10.2.1 In General. Intermountain will provide through Substantial Completion "Builder's Risk" property insurance for the cost of the Project. The policy will be written on an all risk basis, with exclusions standard for the insurance industry, on policy forms currently and commercially available, with insurance carriers selected by Intermountain.
- 10.2.2 Deductible. The above described "Builder's Risk" policies shall be subject to a total deductible of \$5,000 per loss occurrence, which deductible shall be assumed by Contractor or Subcontractors, in proportion to their share of the total amount of an insured loss occurrence.
- 10.2.3 Waiver. To the extent damages are covered by the above described "Builder's Risk" policies, Contractor, including all Subcontractors and Material Suppliers, and Intermountain hereby waive all rights against each other for damages caused by perils insured against under the "Builder's Risk" insurance provided. Contractor will require similar waivers from each of their contractors, subcontractors, material suppliers, sub-consultants and agents, at any tier.
- 10.2.4 Policy Terms. Intermountain will provide a copy of the terms and conditions of the builders risk policy to Contractor upon Contractor's request. Contractor will comply with terms, conditions, and deadlines of the builders risk policy. The terms, conditions, and deadlines of the builders risk policy shall govern coverage. Contractor will cooperate with Intermountain and the builders risk commercial insurer in the investigation, documentation, and settlement of loss claims, including

without limitation promptly responding to all requests for information and documentation from the builders risk commercial insurer and/or Intermountain.

- 10.2.5 Special Hazards. Intermountain will bear the risk of loss, delay and/or damage due to earthquake and/or flood and may either insure or self-insure that risk.

**10.3 Performance Bond and Payment Bond.** If required by the Contract Documents, Contractor will before commencement of the Work or within ten (10) Days after signing the Agreement, whichever is earlier, submit and maintain in full force and effect as required by law and the Contract Documents, as part of the Construction Costs for the Project, written on Form AIA Document A312 (1984) or on other forms provided by Intermountain, and include as part of the quoted total all costs involved in securing and furnishing, a performance bond and a labor and material payment bond the bonds listed below, based on the completed cost of the Contract and effective upon execution of the Contract. These bonds will be from a surety company or companies licensed in the state in which the Project is located and holding valid certificates of authority under Sections 9304 to 9308, Title 31, of the United States Code as acceptable sureties or reinsurance companies on federal bonds, have a penal sum obligation not exceeding the authorization shown in the current revision of Circular #570 as issued by the United States Treasury Department, i.e. "Treasury List", and be accompanied by a certified copy of the power of attorney stating the authority of the attorney-in-fact executing the bonds on behalf of the surety.

- a. A full 100 percent performance bond covering the faithful execution of the Contract in accordance with the Contract Documents; and
- b. A full 100 percent payment bond covering payment of all obligations arising under the Contract Documents, for the protection of each person supplying labor, service, equipment, or material for the performance of the Work.

All Subcontractor performance and payment bonds will name Contractor and Intermountain as Obligee. Intermountain reserves the right to reject any surety company, performance bond, or labor and material payment bond with or without cause.

**10.4 Intermountain Self-Insurance.** Intermountain may, at its option, satisfy any insurance requirements applicable to Intermountain through its self-insurance and risk management program.

## **11. MISCELLANEOUS PROVISIONS.**

**11.1 A/E's Responsibilities.** These General Conditions are not intended to provide an exhaustive or complete list of A/E's responsibilities. A separate agreement between Intermountain and A/E incorporates these General Conditions by reference and includes additional design responsibilities.

**11.2 Successors and Assigns.** Intermountain and Contractor respectively bind themselves, to the other party in respect to covenants, agreements and obligations contained in the Contract Documents. Contractor will not assign the Contract, or any of its rights or obligations under the Contract, without the prior written consent of Intermountain, nor will Contractor assign any amount due or to become due as well as any rights under the Contract, without prior written consent of Intermountain. Intermountain may assign the Contract to an institutional lender providing financing for the Project. In such event, the lender will assume Intermountain's rights and obligations under the Contract. Contractor will execute all consents reasonably required to facilitate such assignment.

**11.3 Written Notice.** Written notice will be deemed to have been duly served if (a) delivered in person to the individual or a member of the firm or entity or to an officer of the corporation for which it was intended, or (b) delivered at or sent by registered or certified mail, return receipt requested, or (c) deposited for delivery with a nationally recognized overnight courier service, to the last business address known to the party giving notice.

**11.4 Rights and Remedies.**

- 11.4.1 **Not Limit.** Duties and obligations imposed by the Contract Documents and rights and remedies available thereunder will be in addition to and not a limitation of duties, obligations, rights and remedies otherwise imposed or available by law.
- 11.4.2 **Not Waiver.** Except as expressly provided elsewhere in the Contract Documents, no action or failure to act by Intermountain, A/E or Contractor will constitute a waiver of a right or duty afforded them under the Contract Documents, nor will such action or failure to act constitute approval or acquiescence in a breach thereunder, except as any of the above may be specifically agreed to in writing. In no case will Contractor or any Subcontractors be entitled to rely upon any waiver of any of these General Conditions unless agreed to in writing by Intermountain.
- 11.5 Use of Intermountain Forms.** Unless otherwise specifically identified in the Contract, all references or requirements for use or submission of documents to Intermountain, to A/E, or to others must be on Intermountain's approved forms. These forms include, without limitation, pay application, requests for payment, proposed change orders, change orders, modifications, requests for information, continuation sheets, waiver and lien releases, verifications, and other project related documents. Notwithstanding, Intermountain may in its sole discretion accept alternate forms. However, Intermountain's acceptance of an alternate form in one instance does not waive or modify the requirements herein for subsequent submissions.
- 11.6 Governing Law, Jurisdiction and Venue.** To the maximum extent permitted by law, Utah laws, excluding its conflict-of-law provisions, govern the Contract and both Intermountain and Contractor submit to the exclusive jurisdiction and venue of state and federal courts located in Salt Lake County, Utah.
- 11.7 Interpretation.** In the interest of brevity, the Contract Documents frequently omit modifying words such as "all" and "any" and articles such as "the" and "an", but the fact that a modification or an article is absent from the statement and appears in another is not intended to affect the interpretation of either statement.
- 11.8 Severability.** The invalidity of any part, paragraph, subparagraph, phase, provision or aspect of the Contract documents will not impair or affect in any manner the validity, enforceability or effect of the remainder of the Contract Documents.
- 11.9 Construction of Words.** Unless otherwise stated in the Contract Documents, words, which have well-known technical or construction industry meanings, will be construed as having such recognized meanings. Unless the context requires otherwise, all other technical words will be construed in accordance with the meaning normally established by the particular, applicable profession or industry. All other words, unless the context requires otherwise, will be construed with an ordinary, plain meaning.
- 11.10 No Third-Party Rights.** The Contract Documents will not be construed to create a contractual relationship of any kind (1) between A/E and Contractor, (2) between Intermountain and a Subcontractor or (3) between any persons or entities other than Intermountain and Contractor. Nothing contained herein will be deemed as creating third party beneficiary contract rights or other actionable rights or duties as between Contractor and A/E, or as between Intermountain, Contractor, or A/E on the one hand, and any other person or entity.
- 11.11 Change of Control.** If a third party acquires a controlling interest (i.e., 50% ownership or more) of Contractor, then (a) Contractor will notify Intermountain within fifteen (15) Days of that acquisition, and (b) upon that acquisition, Intermountain may terminate for cause the Contract immediately upon written notice to Contractor.
- 11.12 Entire Agreement and Amendment Limitation.** The Contract represents the entire and integrated agreement between Intermountain and Contractor and supersedes all prior negotiations, representations or agreements, either written or oral. The Contract may be amended or modified only by (1) a written amendment executed by both Intermountain and Contractor, or (2) by a Modification.

- 11.13 Notices.** Any notice required by the Contract will be served upon the recipient’s designated representative by hand delivery at the last known business address, or by mail or nationally recognized overnight courier service with “delivery confirmation” to the last known address.
- 11.14 No Publicity.** Without receiving prior written approval from an Intermountain vice president, Contractor will not distribute any publicity regarding the Contract.
- 11.15 Waivers.** No waiver by Intermountain or Contractor of any default will constitute a waiver of the same default at a later time or of a different default.
- 11.16 Waiver of Consequential Damages.** Intermountain and Contractor waive all claims against each other for any consequential damages that may arise out of or relate to the Contract. Intermountain waives damages including but not limited to is loss of use of the Project, any rental expenses incurred, loss of income, profit, or financing related to the Project, loss of business, the services of employees, or loss of reputation. Contractor waives damages including but not limited to the loss of business, loss of financing, principal office overhead and expenses, loss of profits not related to this Project, loss of bonding capacity or loss of reputation. This section may not be construed to preclude recovery of consequential damages when such damages are actually recovered from insurance policies required by the Contract Documents. The provisions of this section also apply to the termination of the Contract and survive such termination.
- 11.17 Compliance.**
- 11.17.1 Remuneration. Remuneration flowing between the parties is at fair market value for actual and necessary items furnished or services rendered, is based upon an arm’s-length transaction, and does not take into account, directly or indirectly, the value or volume of any past or future referral or other business generated between the parties (or of any referral or business of any principal, affiliate, or immediate family member - as those terms may be defined by applicable laws - of either party).
- 11.17.2 Financial Relationships. To its knowledge, Contractor (a) is not a physician-owned entity and (b) has no prohibited financial relationship with any physician who is in a position to generate business for Intermountain, or with an immediate family member of that physician. Intermountain defines a “physician-owned entity” as any entity in which a physician, or immediate family member of a physician, holds an ownership, investment, or royalty interest (if royalties are paid on any purchase resulting from the royalty holder’s order). The Code of Federal Regulations (CFR) defines “financial relationship” (in 42 CFR 411.354) and “immediate family member” (in 42 CFR 411.351).
- [Note: Physicians and their immediate family members may own investment securities of Contractor if that investment complies with 42 CFR 411.356(a) or (b), and may have a compensation arrangement that both complies with 42 CFR 411.357(p) and does not take into account the volume or value of referrals or other business generated for Intermountain by a physician or a physician’s immediate family members.]
- 11.17.3 Exclusion or Sanction. Contractor warrants that neither it, or any of its affiliates or employees, excluded from participation in, or sanctioned under, any state or federal healthcare program, including those set forth in 42 U.S.C. §1320a 7b(f). Contractor will notify Intermountain immediately in writing if the warranty in the preceding sentence is, or becomes, inaccurate during the Term.
- 11.17.4 Access to Books and Records. Intermountain is a provider under Federal Medicare programs and is subject to Section 952 of the Omnibus Reconciliation Act of 1980. That law requires Intermountain, as a provider, to include the following provision in its agreements with suppliers who receive \$10,000 or more under an agreement with Intermountain. If requested by the Secretary of HHS, by the U.S. Comptroller, or by an authorized representative of either of them, Contractor will make available to the requestor the Contract and Contractor’s books, documents, and records to allow the requestor to certify the nature and extent of the charges for services provided under the Contract and charged to Medicare. Contractor will continue to make those items available for four years after Contractor



furnishes the final products (or services) under the Contract. If Contractor contracts with another to carry out any of Contractor's duties under the Contract and the Subcontractor is to receive \$10,000 or more in value under that subcontract, then Contractor will obtain a written contractual commitment from the Subcontractor to comply with the obligations of this section of the Agreement. The obligations of this Section survive the expiration or other termination of the Contract.

- 11.17.5 Code of Ethics. In its dealings with Intermountain, Contractor has and will comply with all codes of ethics applicable to suppliers and their interactions with purchasers like Intermountain, including, without limitation, the AdvaMed Code of Ethics on Interactions with Health Care Professionals.
- 11.17.6 Facility Access Policy. All of Contractor's representative(s) entering any Intermountain facility must comply with Intermountain's Facility Access Policy. This policy requires each of these Contractor representatives to check in with Intermountain on each visit to an Intermountain facility to receive an identification badge; and as applicable, log onto: <https://intermountainhealthcare.org/supply-chain-organization/for-suppliers/for-current-suppliers/access-to-intermountain-facilities/> and complete the registration requirements. Please contact Intermountain representative with any questions.
- 11.17.7 Equal Opportunity. Affirmative Action. Intermountain is an equal opportunity employer and federal contractor. Consequently, the parties agree that, to the extent applicable, they will comply with the following, which are incorporated herein by reference: 41 CFR 60 1.4(a), 41 CFR 60 300.5(a), 41 CFR 60 741.5(a), and Executive Order 13496 (29 CFR Part 471, Appendix A to Subpart A), relating to the notice of employee rights under federal labor laws, specifically:
- a. Intermountain and Contractor will abide by the requirements of 41 CFR 60 300.5(a), as applicable. This regulation prohibits discrimination against qualified protected veterans, and requires affirmative action by covered prime contractors and Subcontractors to employ and advance in employment qualified protected veterans.
  - b. Intermountain and Contractor will abide by the requirements of 41 CFR 60 741.5(a), as applicable. This regulation prohibits discrimination against qualified individuals on the basis of disability, and requires affirmative action by covered prime contractors and Subcontractors to employ and advance in employment qualified individuals with disabilities.
- 11.17.8 Remedies. If Contractor breaches any obligation of this section, Intermountain may immediately terminate for cause the Contract upon written notice to Contractor.
- 11.18 Work Restrictions / Drug Testing**. Contractor will ensure that Contractor, its agents, employees, and all Subcontractors do not use or consume alcohol or cannabis, or illegally use drugs, upon Intermountain's property or enter upon or perform any work on Intermountain's property while under their influence. Contractor will obtain necessary consents and will conduct periodic inspections and drug testing to monitor and ensure compliance with these requirements. Contractor will bear the expenses of such inspections and drug testing and will hold Intermountain harmless from all claims arising out of or relative thereto. In addition, Contractor will ensure that Contractor and all Subcontractors do not smoke or vape anything upon Intermountain's property except and only within designated smoking areas approved by Intermountain.
- 11.19 Utah State Sales Tax**. Contractors should be exempt on purchases of material installed or converted into real property to be used by Intermountain. The Contractor will furnish each vendor with Intermountain's Tax exemption number.
- 11.20 Notice of Intent to Obtain Final Completion**. Contractor shall file with the Utah State Construction Registry, on its own behalf and/or on behalf of Intermountain, a notice of intent to obtain final completion at least forty-five (45) Days before the day on which Intermountain or Contractor files or could file a notice of completion under Utah statutes if: (1) the completion of performance time under the original contract for construction work is greater than one hundred twenty (120) Days; (2) the total

original construction contract price exceeds \$500,000; and (3) neither Contractor nor Intermountain has obtained a payment bond in accordance with Utah Code Ann. Section 14-2-1.

**11.21 Notice of Completion.** Within five (5) Days of final completion of the Project and in compliance with Section 38-1a-507 Utah Code Annotated, Contractor shall file with the Utah State Construction Registry, and copy to Intermountain, a notice of completion which shall include, without limitation, the following:

- a. The name, address, telephone number, and email address of the person filing the notice of completion;
- b. The name of the county in which the Project and/or Project site is located;
- c. The date on which final completion is alleged to have occurred;
- d. The method used to determine final completion; and
- e. One of the following:
  1. The tax parcel identification number of each parcel included in the Project and/or Project site;
  2. The entry number of a preliminary notice on the same project that includes the tax parcel identification number of each parcel included in the Project and/or Project site; or
  3. The entry number of the building permit issued for the Project.

Notwithstanding any other provision of the Contract Documents to the contrary, Contractor and Intermountain agree that any breach or failure to comply with this requirement by Contractor will constitute a breach of contract and the Contractor will be liable for any direct, indirect, or consequential damages to Intermountain flowing from this breach.

**11.22 Audit Rights.** Contractor will keep, maintain and preserve complete, current and accurate books, records, and accounts of the transactions contemplated by this Agreement and such additional books, records and accounts as are necessary to establish and verify Contractor's compliance with the Contract. All these books, records and accounts will be available for inspection and audit by Intermountain and/or an independent third party designated by Intermountain and approved by Contractor at any time during the Term and for two (2) years thereafter, but only during reasonable business hours and upon reasonable notice. In addition:

- a. Intermountain agrees that its routine audits will not be conducted more frequently than once in any consecutive twelve (12) month period.
- b. If, after any audit of Contractor, Intermountain requires additional information regarding the transactions contemplated by the Contract, Contractor will furnish to Intermountain or to the third-party audit firm any additional information Intermountain specifies that relates to the audit period to establish and verify Contractor's compliance with the Contract Documents.
- c. Intermountain's right to inspect and audit is without prejudice to any other or additional rights or remedies of either party.
- d. Contractor agrees to not unreasonably withhold approval of any independent third-party audit firm.
- e. If an audit reveals an overcharge incurred by Intermountain on this Project, Contractor will provide a written response explanation, correct any error and remit any monies due within ten (10) Days after receiving notice of the error or overcharge.

Intermountain may audit applications for payments or any other aspect of the Services and Work of Contractor and of the Subcontractor or suppliers at any tier. Contractor will cooperate with Intermountain in providing all necessary information for any Intermountain audit.

## **12. TERMINATION OR SUSPENSION OF THE CONTRACT.**

### **12.1 Termination by Contractor.**

- 12.1.1 In General. If the Work is stopped for a period of ninety (90) Days through no act or fault of Contractor or a Subcontractor, or their agents or employees or any other persons performing portions of the Work under contract with any of the above, Contractor, may terminate the Contract in accordance with 12.1.2 herein below for any of the following reasons:
- a. Because Intermountain has persistently failed to fulfill fundamental Intermountain's obligations under the Contract Documents with respect to matters important to the progress of the Work;
  - b. Issuance of an order of a court or other public authority having jurisdiction which necessitates such termination, except that where Contractor has standing, Contractor must cooperate in efforts to stay and/or appeal such order;
  - c. A governmental declaration of national emergency, making material unavailable; or
  - d. Unavoidable casualties or other similar causes as listed in Paragraph 12.2.2(2) herein below.
- 12.1.2 Notice. If one of the reasons for termination in Paragraph 12.1.1 hereinabove exist, Contractor may, upon ten (10) additional Days' written notice to Intermountain and A/E, and such condition giving cause for termination still not cured, terminate the Contract and recover from Intermountain payment for Work executed and for proven loss with respect to materials, equipment, tools, and construction equipment and machinery, including reasonable overhead, profit and damages associated only with work completed before the notice of termination.

### **12.2 Termination by Intermountain for Cause.**

- 12.2.1 In General. Intermountain may terminate the Contract if Contractor fails to cure any of the following within a period of ten (10) Days (or longer if Intermountain so approves in writing) after receipt of notice from Intermountain specifying the cause for termination:
- a. Contractor refuses or fails to supply enough properly skilled workers or proper materials;
  - b. Contractor fails to make payment to Subcontractors for materials or labor in accordance with the respective agreements between Contractor and the Subcontractors;
  - c. Contractor disregards laws, ordinances, or rules, regulations, resolutions or orders of a public authority having jurisdiction; or
  - d. Contractor fails to perform the Work within the time specified in the Contract Documents or any authorized extension thereof or Contractor fails to make progress with the Work as to endanger such compliance;
  - e. Contractor fails to perform the Work or is otherwise in breach of a provision of the Contract Documents;
  - f. Contractor fails to respond promptly to the financial responsibility inquiry herein;
  - g. As permissible by law for a reason to terminate, Contractor is adjudged bankrupt;
  - h. As permissible by law for a reason to terminate, Contractor should make a general assignment for the benefit to creditors;
  - i. As permissible by law for a reason to terminate, Contractor has or should have a receiver appointed on account of Contractor's insolvency; or
  - j. Contractor fails to follow the material safety requirements and precautions either as expressly provided in the Contract Documents or as consistent with the customary practices in the industry.

- 12.2.2 Intermountain's Right to Carry Out the Work. If Contractor defaults or neglects to carry out the Work in accordance with the Contract Documents and fails within a ten (10) Day period (or longer if approved by Intermountain in writing) after receipt of written notice from Intermountain to cure such default or neglect, Intermountain may without prejudice to other remedies Intermountain may have, correct such deficiencies, including taking over the Work and prosecuting the same to completion, by contract or otherwise, and may take possession of, and utilize in completing the Work, such materials, appliances, and facilities as may be on the site of the Work as well as the site as necessary for its proper completion. In such case, Intermountain will offset from payments then or thereafter due Contractor the cost of correcting such deficiencies, including compensation for A/E, Intermountain's staff and legal counsel's additional services and expenses made necessary by such default, neglect or failure. If payments then or thereafter due Contractor are not sufficient to cover such amounts, Contractor will pay the difference to Intermountain. Contractor will continue performance of the Contract to the extent not terminated.
- 12.2.3 Items Required to Be Transferred or Delivered. Intermountain may require Contractor to transfer title and deliver to Intermountain, in the manner and to the extent directed by Intermountain:
- a. Any completed portion of the Work; and
  - b. Any partially completed portion of the Work and any parts, tools, dies, jigs, fixtures, drawings, information, and contract rights (hereinafter called "construction materials") as Contractor has specifically produced or specifically acquired for the performance of such part of this Contract as has been terminated; and Contractor will, upon direction of Intermountain, protect and preserve property in the possession of Contractor in which Intermountain has an interest.
- 12.2.4 Payment. When Intermountain terminates the Contract for one or more of the reasons stated in Paragraph 12.2.1, Intermountain may withhold payment and/or pursue all available remedies.
- 12.2.5 Intermountain Protection If Lienable. When the subject property is lienable, Intermountain may withhold from amounts otherwise due Contractor for such completed Work or construction materials such sum as Intermountain determines to be necessary to protect Intermountain against loss because of outstanding liens or claims for former lien holders.
- 12.2.6 Credits and Deficits. If the unpaid balance of the Contract Sum exceeds the full cost of finishing the Work, including compensation for A/E's services and expenses made necessary thereby, such excess will be paid to Contractor. If such cost exceeds the unpaid balance, Contractor will pay the difference to Intermountain this obligation for payment will survive the termination of the Contract.
- 12.2.7 If Contractor Found Not in Default or Excusable. If, after notice of termination of the Contract under the provisions of this Article, it is determined for any reason that Contractor was not in default under the provisions of this Article, or that the default was excusable under the provisions of this Article, the rights and obligations of the parties will be the same as if the notice of termination had been issued pursuant to the termination for convenience provisions.
- 12.2.8 Rights and Remedies Not Exclusive. The rights and remedies of Intermountain provided in this Article 12.2 will not be exclusive and are in addition to any other rights and remedies provided by law or under this Contract.

### **12.3 Suspension, Delay or Interruption of Work by Intermountain for Convenience.**

- 12.3.1 By Intermountain in Writing. Intermountain may in writing and without cause, order Contractor to suspend, delay or interrupt the Work in whole or in part for such period of time as Intermountain may determine to be appropriate for the convenience of Intermountain.
- 12.3.2 Adjustments. Any adjustment in Contract Sum and Contract Time will be in accordance with Articles 3, 4, and 7.

## 12.4 Termination for Convenience of Intermountain.

- 12.4.1 In General. The performance of Work under this Contract may be terminated by Intermountain in accordance with this Article 12.4 in whole, or from time to time, in part, whenever Intermountain will determine that such termination is in the best interest of Intermountain or any person for whom Intermountain is acting under this Contract. Any such termination will be effected by delivery to Contractor of a notice of termination specifying the extent to which performance of Work under the Contract is terminated, and the date upon which such termination becomes effective.
- 12.4.2 Contractor Obligations. After receipt of a notice of termination, and except as otherwise directed by Intermountain in writing, Contractor will:
- a. Stop work under the Contract on the date and to the extent specified in the notice of termination;
  - b. Place no further orders or subcontracts for materials, services or facilities, except as may be necessary for completion of such portion of the Work under the Contract as is not terminated;
  - c. Terminate all orders and subcontracts to the extent that they relate to performance of Work terminated by the notice of termination;
  - d. Assign to Intermountain in the manner, at the times, and to the extent directed by Intermountain, all of the right, title and interest of Contractor under the orders and subcontracts so terminated, in which case Intermountain will have the right, in its discretion, to settle or pay any or all claims arising out of the termination of such orders and subcontracts;
  - e. Settle all outstanding liabilities and all claims arising out of such termination of orders and subcontracts, with the approval or ratification of Intermountain, which approval or ratification will be final for all the purposes of this Article 12.4;
  - f. Transfer title and deliver to Intermountain in the manner, at the times, and to the extent, if any, directed by Intermountain:
    - (i) The fabricated or unfabricated parts, work in process, completed work, supplies, and other material produced as a part of, or acquired in connection with the performance of the Work terminated by the notice of termination; and
    - (ii) The completed or partially completed drawings, information, and other property which, if the Contract had been completed, would have been required to be furnished to Intermountain;
  - g. Use best efforts to sell, in the manner, at the times, to the extent, and at the price or prices directed or authorized by Intermountain, any property of the types referred to in Paragraph 12.4.2.f above; provided, however, that Contractor:
    - (i) Will not be required to extend credit to any purchaser; and
    - (ii) May acquire any such property under the conditions prescribed by and at a price or prices approved by Intermountain; and provided further that the proceeds of any such transfer of or disposition will be applied in reduction of any payments to be made by Intermountain to Contractor under this Contract or will otherwise be credited to the Contract Sum or paid in such other manner as Intermountain may direct;
  - h. Complete performance of such part of the Work as will not have been terminated by the notice of termination; and
  - i. Take such action as may be necessary, or as Intermountain may direct, for the protection and preservation of the property related to this Contract which is in the possession of Contractor in which Intermountain has or may acquire an interest.

- 12.4.3 Agreed Upon Payment. Subject to the provisions of Paragraph 12.4.2 above, Contractor and Intermountain may agree upon the amount to be paid to Contractor by reason of the total or partial termination of Work pursuant to this Article 12.4.
- 12.4.4 Payment Not Agreed Upon. In the event of the failure of Contractor and Intermountain to agree, as provided in Paragraph 12.4.3, upon the whole amount to be paid to Contractor by reason of the termination of Work pursuant to this Article 12.4, Intermountain will pay to Contractor the portion of the Contract Sum requisite with the portion of the Work completed as determined by Intermountain as of the date of termination, subject to offsets if any.
- 12.4.5 Deductions. In arriving at the amount due Contractor under this Article 12.4, there will be deducted:
- a. All unliquidated advance or other payments on account theretofore made to Contractor, applicable to the terminated portion of this Contract;
  - b. Any Claim which Intermountain may have against Contractor in connection with this Contract; and
  - c. The agreed price for, or the proceeds of sale of, any materials, supplies, or other things acquired by Contractor or sold, pursuant to the provisions of this Article 12.4, and not otherwise recovered by or credited to Intermountain.
- 12.4.6 Partial Payments. Intermountain may, from time to time, under such terms and conditions as it may prescribe, make partial payments and payments on account against cost incurred by Contractor in connection with the terminated portion of this Contract whenever, in the opinion of Intermountain the aggregate of such payments will be within the amount to which Contractor will be entitled hereunder. If the total of such payments is in excess of the amount finally agreed or determined to be due under this Article 12.4, such excess will be payable by Contractor to Intermountain upon demand, together with interest at a rate of five percent (5%) per annum for the period until the date such excess is repaid to Intermountain; provided, however, that no interest will be charged with respect to any such excess payment attributable to a reduction in Contractor's claim by reason of retention or other disposition of termination inventory until ten (10) Days after the date of such retention or disposition, or such later date as determined by Intermountain by reason of the circumstances.
- 12.4.7 Preserve and Make Available Records. Unless otherwise provided for in this Contract, or by applicable law, Contractor will, from the effective date of termination until the expiration of three years after final settlement under this Contract, preserve and make available to Intermountain at all reasonable times at the office of Contractor, but without direct charge to Intermountain, all books, records, documents and other evidence bearing on the costs and expenses of Contractor under this Contract and relating to the Work terminated hereunder, or, to the extent approved by Intermountain Representative, photographs, micrographs, or other authentic reproductions thereof.
- 12.4.8 Intermountain's Right to Stop the Work. If Contractor fails to correct Work or fails to carry out Work, as required by the Contract Documents or fails to comply with all required and customary safety precautions; Intermountain, by written order signed personally or by an agent specifically so empowered by Intermountain in writing, may order Contractor to stop the Work, or any portion thereof, until the cause for such order has been eliminated; however, the right of Intermountain to stop the Work will not give rise to a duty on the part of Intermountain to exercise this right for the benefit of Contractor or any other person or entity.

END OF DOCUMENT

**SECTION 011000 - SUMMARY**

## PART 1 - GENERAL

## 1.1 RELATED DOCUMENTS

- A. Drawings and general provisions of the Contract, including General and Supplementary Conditions and other Division 1 Specification Sections, apply to this Section.

## 1.2 SUMMARY

- A. This Section includes the following:
  - 1. Work covered by the Contract Documents.
  - 2. Use of premises.
  - 3. Code compliance
  - 4. Dust control
  - 5. Protection of existing improvements
  - 6. Traffic Control
  - 7. Temporary Controls

## 1.3 WORK COVERED BY CONTRACT DOCUMENTS

Project Identification: Project includes remodel of existing pulmonology clinic to add three new exam rooms and shared office areas and associated spaces as outlined in the construction documents.

- A. Total square feet: 1,409 SF.

Project Location: McKay Dee Hospital, Level 4  
Address: 4401 Harrison Blvd, Ogden, UT 84403

- B.
  - 1. Owner: Intermountain Healthcare, 36 South State Street, 23rd Floor  
Salt Lake City, Utah 84111
  - 2. Owner's Representative: Kurt Wilson, Construction Project Manager
- C. Architect: NJRA Architects, 5223 S Ascension Way, Suite 350, Murray, Utah 84123.
- D. The Work consists of the following:
  - 1. The Work includes: Remodel of existing Pulmonary Clinic to add three exam rooms and repurpose shared offices areas and associated spaces as shown on the contract documents.

## 1.4 USE OF PREMISES

- A. Contractor's use of premises is limited only by Owner's right to perform work or to retain other contractors on portions of Project.
- B. Assume full responsibility for the protection and safekeeping of products under this Contract, stored on the site.

## 1.5 CODE COMPLIANCE

- A. All work shall comply with current edition of codes including but not limited to the following:
  - 1. International Building Code
  - 2. International Mechanical Code
  - 3. International Plumbing Code
  - 4. NFPA
  - 5. National Electric Code
  - 6. OSHA Regulation
  - 7. Health and Safety Regulations
  - 8. Utility Company Regulations
  - 9. Police, Fire Department Rules
  - 10. Environmental Protection Regulations
  - 11. Americans with Disabilities Act
- B. Arrange for authorities having jurisdiction to inspect and test according to their requirements and for each temporary utility before use. Obtain required certifications and permits.
- C. Requirements of codes and regulations shall be considered as the minimum. Where the contract documents exceed (without violating) code and regulation requirements, contract requirements shall take precedence. Where codes conflict, the more stringent shall apply.

## 1.6 DUST CONTROL

Temporary partitions should be constructed as called out on the Contract Documents and as mentioned in specification Section 024119 – Selective Demolition.

## 1.7 PROTECTION OF EXISTING IMPROVEMENTS

- A. Take precautions necessary to protect all existing utilities, monitor wells, and other Site improvements to remain from damage due to the work of this Project.
- B. Provide restoration of damaged property if damage is a result of construction activities.



1.8 TRAFFIC CONTROL

- A. Maintain control of vehicular and pedestrian traffic caused by, or resulting from, the work of this Project.
- B. Means of control shall be in accordance with the applicable regulations of the jurisdiction responsible for traffic safety.

1.9 TEMPORARY CONTROLS

- A. Conform to all applicable state and local ordinances and regulations. Obtain and pay for necessary permits and licenses as required by local jurisdictions.

END OF SECTION

**SECTION 012300 - ALTERNATES****PART 1 - GENERAL****1.1 SUMMARY**

- A. Section identifies each Alternate by number and describes basic changes to be incorporated into Work, only when that Alternate is made a part of Work by specific provisions in Construction Contract.
- B. Section includes only nontechnical descriptions of Alternates.
- C. Refer to specific Sections of Specifications and Drawings for technical description of Alternates.
- D. Coordinate related Work, and modify surrounding Work as required to properly integrate Work under each Alternate and to provide complete construction required by Contract Documents.

**1.2 DESCRIPTION**

- A. Work includes:
  - 1. Indicate Alternate prices on Bid Form.
  - 2. Alternates will be selected after bids are evaluated.
  - 3. Selected Alternates will be made a part of Contract and final Contract Amount will be adjusted accordingly.

**1.3 ALTERNATES**

- A. Alternate No. 1: Work in MA workstation A420:**  
The base bid for this alternative should exclude work in MA workstation A420. Add Alternate #1 involves all work in MA workstation A420.
- B. Alternate No. 2: Carpet Flooring and Base:**  
The base bid for this alternate should encompass patching existing carpet flooring and base as indicated. Add Alternate #2 involves replacing existing carpet flooring and base with new carpet flooring and carpet base as indicated on finish plans and finish schedule in the following rooms: Shared Office A401, Corridor A403, Shared Office A404, Shared Office A405, Shared Office A407, and Shared Office A408.

**PART 2 - PRODUCTS - NOT USED****PART 3 - EXECUTION - NOT USED****END OF SECTION**

**SECTION 012900 – PAYMENT PROCEDURES**

## PART 1 - GENERAL

## 1.1 SUMMARY

- A. Section includes measurement and payment provisions for, but not limited to, the following:
  - 1. Materials Delivered but Not Yet Installed.
  - 2. Schedule of Values.
  - 3. Applications for Payment.
  - 4. Preliminary Progress Schedule.
  - 5. Construction Progress Schedule.
  - 6. Change Orders.

## 1.2 MATERIALS DELIVERED BUT NOT INSTALLED

- A. Exclude from Applications for Payment materials or equipment delivered and stored, but not yet incorporated into the Work, unless circumstances dictate acceptance (i.e. pre-purchase of equipment for early delivery to prevent delay of construction or subsequent facility opening date) and pre-payment is agreed to, in writing, by the Owner.
- B. If Owner has agreed to make early payment on account of materials or equipment not incorporated in the Work, but delivered and stored in conformance with the requirements of the Contract Documents, at the site, or at some other location agreed upon in writing, such pre-payment shall be conditioned upon approval by Contractor's Insurance Carrier, and Architect, in writing, prior to submission by Contractor of the applicable payment request.
- C. Pre-payment request shall contain substantiating documentation, including:
  - 1. Bill(s) of Sale.
  - 2. Evidence of insurance for the materials or equipment, covering the item(s) until completion of installation.
  - 3. Provision for transportation to the Project Site.
  - 4. Protection of Owner's interest under any circumstance (i.e. Owner's right to retrieve equipment or materials from storage area of a bankrupt company's property).
  - 5. Provision for inspection/testing at the stored location.
  - 6. Provision for security until completion of installation.

## 1.3 SCHEDULE OF VALUES

- A. Type schedule on Intermountain standard form. Owner's Standard Invoice/Schedule of Values or Contractor's standard forms and automated printout equivalent to the IH standard form will be considered for approval by Owner upon Contractor's request. Identify schedule with:
1. Title of Project and location.
  2. Architect and Project number.
  3. Name and Address of Contractor.
  4. Contract designation.
  5. Date of submission.
- B. Schedule shall list the installed dollar value of the component parts of the Work in sufficient detail to serve as a basis for computing values for progress payments during construction.
- C. List each subcontract first using the Table of Contents of the Project Manual as the format.
1. Next list any allowances included in the contract amount.
  2. List each major section or portion of work to be performed by the Contractor.
  3. List Contractor's fee separately.
  4. List any contingencies.
  5. Identify each line item with the number and title of the respective major section of the specifications.
  6. Subdivide items to correspond with cost correlation requirements for construction progress schedule.
- D. For each major line item list sub-values of major products by building area or floor level or other operations under the item.
- E. For the various portions of the Work:
1. Each item shall include a directly proportional amount of the Contractor's overhead and profit.
  2. For items on which progress payments will be requested for stored materials, break down the value into:
    - a. The cost of the materials, delivered and unloaded, with taxes paid.
    - b. The total installed value.
- B. The sum of all values listed in the schedule shall equal the total Contract Sum.

- C. Refer to General Conditions, Article 12, for changes.

#### 1.4 APPLICATIONS FOR PAYMENT

- A. Format and Data Required:

1. Submit applications typed on Intermountain Healthcare Application and Certification for Payment form.
2. Submit 2 copies with "wet" signatures.
3. Add provision for Inspector of Record's signature.

- B. Provide itemized data on continuation sheet:

1. Format, schedules, line items and values: Those of the Schedule of Values accepted by Architect.
2. Include Payment Application number.

- C. Preparation of Application for Each Progress Payment:

1. Application Form:

- a. Fill in required information, including that for Change Orders executed prior to date of submittal of application along with the number assigned to each Change Order.
- b. Fill in summary of dollar values to agree with respective totals indicated on continuation sheets.
- c. Certification that the Project Record Documents are current with the progress status of the Project.
- d. Execute certification with signature of a responsible officer of Contract firm.

2. Continuation Sheets:

- a. Fill in total list of all scheduled component items of Work, with item number and scheduled dollar value for each item.
- b. Fill in dollar value in each column for each scheduled line item when work has been performed or products stored.
  - 1) Round off values to nearest dollar, or as specified for Schedule of Values, and percent of item completion.
- c. List each Change Order executed prior to date of submission, at the end of the continuation sheets.
  - 1) List by Change Order number, and description, as for an original component item of work.

## D. Substantiating Data for Progress Payments:

1. When Owner or Architect requires substantiating data, submit information, with a cover letter identifying:
  - a. Project.
  - b. Application number and date.
  - c. Detailed list of enclosures.
  - d. For stored products.
    - 1) Item number and identification as shown on application.
    - 2) Description of specific Material.
2. Submit 1 copy of data and cover letter for each copy of application.
3. Revised updated CPM schedule.
4. Current period's General Contractor Conditional Waiver and the prior period's Unconditional Waiver.
5. Waivers from Subcontractors.
6. Copies of invoices for National Purchase Agreement (NPA) items.
7. Corrections and updates to "as-built" documents.

## E. Preparation of Application for Final Payment:

1. Fill in application form as specified for progress payments.
2. Use continuation sheet for presenting the final statement of accounting as specified in Section 01700 - CONTRACT CLOSEOUT.

## F. Submittal Procedure:

1. Submit Applications for Payment to Owner at the times stipulated in the Agreement.
2. Number: 3 copies of each Application.
3. When Owner, Inspector of Record, and Contractor agree on percentages to be requested, and when agreed and signed by them and Architect, Architect will transmit the Certificate for Payment to Owner.
4. Approval and signing of the Application for Payment by Owner and Architect is contingent upon approval of the current status of the As-Built Drawings/Record Documents and submittal of updated CPM schedule.

## 1.5 CHANGE ORDERS

- A. Change Orders shall be processed by the Architect in accordance with the Conditions of the Contract, Supplementary Conditions of the Contract, and as herein specified.
- B. Coordination with Contractor's Submittals:
  - 1. Revise Schedule of Values and Application for Payment forms monthly to record each change as a separate item of Work, and to record the adjusted Contract Sum.
  - 2. Upon completion of work under a Change Order, enter pertinent changes in record documents.

PART 2 – PRODUCTS (Not Used)

PART 3 – EXECUTION (Not Used)

END OF SECTION

**SECTION 013100 – PROJECT MANAGEMENT AND COORDINATION**

PART 1 - GENERAL

1.1 SUMMARY

- A. This Section describes the requirements for Project coordination.

1.2 DESCRIPTION OF REQUIREMENTS

- A. Minimum administrative and supervisory requirements necessary for coordination of Work shall be fulfilled collectively by the Contractor in coordination with subcontractors including, but not necessarily limited to, the following:

- 1. Coordination drawings.
- 2. Coordination meetings.
- 3. Administrative coordinating personnel.
- 4. Contractor's coordination of work.

1.3 COORDINATION MEETINGS

- A. Schedule and conduct meetings and conferences at project site, unless otherwise indicated.

1.4 ADMINISTRATIVE COORDINATION PERSONNEL

- A. Provide a General Superintendent and other administrative and supervisory personnel required for performance of the Work.
- B. Provide specific coordinating personnel for each subcontractor as reasonably required for interfacing Work with other work of total Project.
- C. Submittal of Staff Names, Duties: Within 7 days of Notice to Proceed submit to the Owner a listing of principal staff assignments and consultants, including names, addresses and telephone numbers.

1.5 CONTRACTOR'S COORDINATION OF WORK

- A. Provide and coordinate the following:
  - 1. General and special services and operations to furnish and install Work.
  - 2. Primary, major and accessory materials, and items necessary to complete the installation.
  - 3. Labor operations and material items reasonably incidental for finishing.



4. Performance of work and delivery of materials in accordance with established construction schedules.
- B. Coordinate all aspects of construction operations, generally, and specifically as required to provide Owner with a complete, operable facility.
1. Resolve any dispute over coordination, or failure to coordinate, such that resolution is consistent with Contract Documents. When such resolution is not possible, refer to the General Conditions.
  2. Where proper execution of this Work depends on the work of any other contractor, inspect and promptly report to Architect any defects in such work that render it unsuitable for such proper execution and results.
  3. Cooperate with other contractors on the Project site and with Architect so that completion of all work can proceed with prudent speed.
    - a. Furnish other contractors, whose work is fitted to this work, detail and erection drawings giving full information regarding the fabrication and assembly of this Work.
    - b. So far as possible, drawings shall indicate checked field measurements.
    - c. Cooperate in timing this Work to join with the work of other contractors or the Owner.
  4. Check the drawings of other contracts for interferences with this Work and promptly report to Architect, in writing, any such interferences.
  5. Submit complete information, including Drawings, descriptions, sketches, marked prints, etc., as required for Architect's review and coordination of drawings by others which are a part of this Work.
- C. Mechanical, Electrical, and Related Systems Coordination: Prior to proceeding with the work, and before installation, coordinate and work out all "tight" conditions involving work of various Sections.
1. Before work proceeds in these areas, prepare supplemental drawings for review by the Architect.
  2. Provide all work necessary to coordinate tight conditions, including supplemental drawings in sufficient detail for showing that all work is coordinated in "tight" areas, and additional labor and materials necessary to overcome "tight" conditions at no increase in cost to the Owner.
  3. Coordination of "tight" conditions shall include:
    - a. Providing sufficient clear space around all equipment necessary for maintenance access and as required by Code.
    - b. Adjustments in depth, position, and elevation of underground and overhead utilities at points of conflict. Utility space conflicts

shall be resolved by giving precedence to those utilities which are called out to be sloped. The term "utility" as used in this paragraph includes: all piping, conduit, and ductwork.

## 1.6 COORDINATION DRAWINGS

- A. Submit plans and cross-sections in sufficient detail to show coordinated layout of all ducts, pipes, electrical work, access doors, above ceiling clearances, canopy rigging, acoustical curtains, and other related items. Plans and cross-sections shall be provided that include all underground ducts, electrical ductbanks, piping, and other underground utilities.
- B. Engage professional drafter to prepare these drawings to one-quarter scale on Auto-CAD with title blocks to match the Contract Drawings.
  - 1. These plans shall reflect existing dimensions as field-verified by the Contractor.
  - 2. Plans shall be uniform and identical and shall serve as backgrounds for preparation of shop or layout drawings required under Divisions 15 and 16 and ultimately for recording of as-built information required under these divisions.
  - 3. Where additional sheets of elevations, sections, details, and/or diagrams are required, such sheets shall match the Contract Drawings with respect to size and title block.
  - 4. Prior to beginning excavation for structural footings and utilities, submit a coordination plan showing all underground utilities including: all underground piping, underground ductwork, electrical and communication ductbanks.
    - a. The plan shall be a composite overlay of sheets each dedicated to a single underground utility using a common background and scale.
    - b. Dimensions shall be sufficient to clearly indicate the position and depth of each utility relative to structural footings, above grade structures, and finished grade.
    - c. At points where the plan indicates that utilities will cross each other, cross a structural footing, or run within six (6) feet parallel to either each other or a structural footing, provide a cross section drawing.
    - d. Cross section drawings shall clearly show the relative positions and depths of each utility and structural footing.
    - e. The composite plan and cross section drawing(s) shall be updated to "as-builts" and submitted with the Project Record (As-Built) Drawings.
- C. Do not commence work until the Architect has reviewed these Drawings.

1.7 MISCELLANEOUS PROVISIONS

- A. Prior to starting a particular type or kind of work:
1. Examine for relevant information, all Contract Documents and subsequent data issued;
  2. Check accepted submittals and verify dimensions at job site;
  3. Consult manufacturers for instructions applicable to conditions under which Work is to be installed;
  4. Inspect areas, surfaces or construction receiving the Work.
    - a. Start of work shall signify compliance with the above requirements and acceptance of previously placed construction or substrates as being in satisfactory condition to achieve proper installations and first quality workmanship as intended under these specifications.
    - b. Failure to so inspect and report shall constitute an acceptance of the other contractor's work.

PART 2 – PRODUCTS (Not Used)

PART 3 – EXECUTION (Not Used)

END OF SECTION

**SECTION 013110 – FIELD ENGINEERING**

## PART 1 - GENERAL

## 1.1 FIELD MEASUREMENTS AND EXISTING CONDITIONS

- A. Contractor Responsibility: Exact field measurements are responsibility of the Contractor. Any required off-sets, additional fittings, re-routing of existing or new work to provide serviceable system within the location shown, and to maintain head room and clearances to match existing construction, are responsibility of the Contractor.
- B. Layout of the Work: The Contractor shall employ, at the Contractor's own expense, Registered Civil Engineer or Licensed Land Surveyor. Contractor's engineer or surveyor will provide layout of the work of the Project and establish all reference points and elevations required for construction.

## 1.2 GRADES, LINES AND LEVELS

- A. Identification: Owner will identify existing benchmarks, control points, and property corners.
- B. Reference Points: Locate existing permanent benchmarks, control points, and similar reference points before beginning the Work. Preserve and protect permanent benchmarks and control points during construction operations.
- C. Benchmarks: Establish and maintain a minimum of six permanent benchmarks on Project site, referenced to data established by survey control points. Comply with authorities having jurisdiction for type and size of benchmark.
  - 1. Record benchmark locations, with horizontal and vertical data, on Project Record Documents.
  - 2. Where the actual location or elevation of layout points cannot be marked, provide temporary reference points sufficient to locate the Work.
  - 3. Remove temporary reference points when no longer needed. Restore marked construction to its original condition.
- D. Preservation: All stakes, boundary lines, bench marks or survey marks, etc., which have been or may be established in any part of the Project site or adjacent thereto shall be carefully preserved and respected by the Contractor and shall be restored at the Contractor's expense if lost or destroyed as result of the Contractor's operations.
  - 1. Replace lost or destroyed permanent benchmarks and control points promptly. Base replacements on the original survey control points.
- E. Conflict: The Contractor will be held responsible for correctness of layout, for

establishing location of existing concealed utility lines, and for notifying the Architect in writing in event of conflict with the Drawings. In such case, the Contractor shall not proceed until instructed by the Architect.

- F. Certified Survey: On completion of foundation walls, major site improvements, and other work requiring field-engineering services, prepare a certified survey showing dimensions, locations, angles, plumbness and elevations of construction and sitework.
- G. Final Property Survey: Prepare a final property survey showing significant features (real property) for Project. Include on the survey a certification, signed by land surveyor that principal metes, bounds, lines, and levels of Project are accurately positioned as shown on the survey.
  - 1. Show boundary lines, monuments, streets, site improvements and utilities, existing improvements and significant vegetation, adjoining properties, acreage, grade contours, and the distance and bearing from a site corner to a legal point.

END OF SECTION

**SECTION 013300 - SUBMITTAL PROCEDURES**

## PART 1 - GENERAL

## 1.1 RELATED DOCUMENTS

- A. Drawings and general provisions of the Contract, including General and Supplementary Conditions and other Division 1 Specification Sections, apply to this Section.

## 1.2 SUMMARY

- A. This Section includes administrative and procedural requirements for submitting Shop Drawings, Product Data, Samples, and other submittals.

## 1.3 SUBMITTAL PROCEDURES

- A. General: Electronic copies of CAD Drawings of the Contract Drawings will not be provided by Architect for Contractor's use in preparing submittals.
- B. Coordination: Coordinate preparation and processing of submittals with performance of construction activities.
- C. Submittals Schedule: Comply with requirements in Division 1 Section "Construction Progress Documentation" for list of submittals and time requirements for scheduled performance of related construction activities. Submittals should be submitted by contractor to architect **within 30 days from notice to proceed**.
- D. Processing Time: Allow enough time for submittal review, including time for resubmittals, as follows. Time for review shall commence on Architect's receipt of submittal. No extension of the Contract Time will be authorized because of failure to transmit submittals enough in advance of the Work to permit processing, including resubmittals.
  - 1. Initial Review: Allow 10 days for initial review of each submittal. Allow additional time if coordination with subsequent submittals is required. Architect will advise Contractor when a submittal being processed must be delayed for coordination.
  - 2. Resubmittal Review: Allow 10 days for review of each resubmittal.
- E. Identification: Place a permanent label or title block on each submittal for identification.
  - 1. Indicate name of firm or entity that prepared each submittal on label or title block.
  - 2. Include the following information on label for processing and recording action taken:
    - a. Project name.
    - b. Date.

- c. Name and address of Architect.
  - d. Name and address of Contractor.
  - e. Name and address of subcontractor.
  - f. Name and address of supplier.
  - g. Name of manufacturer.
  - h. Submittal number or other unique identifier, including revision identifier.
  - i. Number and title of appropriate Specification Section.
  - j. Drawing number and detail references, as appropriate.
  - k. Location(s) where product is to be installed, as appropriate.
- F. Transmittal: Package each submittal individually and appropriately for transmittal and handling. Transmit each submittal using a transmittal form.
- G. Distribution: Furnish copies of final submittals to manufacturers, subcontractors, suppliers, fabricators, installers, authorities having jurisdiction, and others as necessary for performance of construction activities.
1. Use for Construction: Use only final submittals with mark indicating "Approval notation from Architect's action stamp".

## PART 2 - PRODUCTS

### 2.1 ACTION SUBMITTALS

- A. General: Prepare and submit Action Submittals required by individual Specification Sections.
- B. Product Data: Collect information into a single submittal for each element of construction and type of product or equipment.
1. Mark each copy of each submittal to show which products and options are applicable.
  2. Include the following information, as applicable:
    - a. Manufacturer's written recommendations.
    - b. Manufacturer's product specifications.
    - c. Manufacturer's installation instructions.
    - d. Standard color charts.
    - e. Manufacturer's catalog cuts.
    - f. Standard product operation and maintenance manuals.
    - g. Compliance with specified referenced standards.
  3. Submit Product Data concurrent with Samples.
  4. Number of Copies: Submit four copies of Product Data, unless otherwise indicated.
- C. Shop Drawings: Prepare Project-specific information, drawn accurately to scale. Do not base Shop Drawings on reproductions of the Contract Documents or standard printed data.
1. Preparation: Fully illustrate requirements in the Contract Documents. Include the following information, as applicable:

- a. Dimensions.
  - b. Identification of products.
  - c. Fabrication and installation drawings.
  - d. Roughing-in and setting diagrams.
  - e. Wiring diagrams showing field-installed wiring, including power, signal, and control wiring.
  - f. Shopwork manufacturing instructions.
  - g. Schedules.
  - h. Design calculations.
  - i. Compliance with specified standards.
  - j. Relationship to adjoining construction clearly indicated.
2. Sheet Size: Except for templates, patterns, and similar full-size drawings, submit Shop Drawings on sheets at least 8-1/2 by 11 inches (215 by 280 mm) but no larger than 30 by 40 inches (750 by 1000 mm).
  3. Number of Copies: Submit four opaque copies of each submittal, Architect will retain two copies; remainder will be returned.
- D. Samples: Submit Samples for review of kind, color, pattern, and texture for a check of these characteristics with other elements and for a comparison of these characteristics between submittal and actual component as delivered and installed.
1. Samples for Initial Selection: Submit manufacturer's color charts consisting of units or sections of units showing the full range of colors, textures, and patterns available.
    - a. Number of Samples: Submit one full set of available choices where color, pattern, texture, or similar characteristics are required to be selected from manufacturer's product line. Architect will return submittal with options selected.

### PART 3 - EXECUTION

#### 3.1 CONTRACTOR'S REVIEW

- A. Review each submittal and check for coordination with other Work of the Contract and for compliance with the Contract Documents. Note corrections and field dimensions. Mark with approval stamp before submitting to Architect.

#### 3.2 ARCHITECT'S ACTION

- A. General: Architect will not review submittals that do not bear Contractor's approval.
- B. Action Submittals: Architect will review each submittal, make marks to indicate corrections or modifications required, and return it. Architect will stamp each submittal with an action stamp and will mark stamp appropriately to indicate action taken, as follows:

END OF SECTION



**SECTION 014000 – QUALITY REQUIREMENTS**

## PART 1 - GENERAL

## 1.1 SUMMARY

- A. This Section describes the requirements for Owner furnished testing and inspection services which include the following:
  - 1. Observation by Inspector of Record.
  - 2. Laboratory responsibilities.
  - 3. Laboratory reports.
  - 4. Limits on testing laboratory authority.
  - 5. Contractor responsibilities.
  - 6. Schedule of inspections and tests.
- B. These services are identified to indicate the requirement for cooperation and assistance needed by Owner's testing and inspection agency.

## 1.2 QUALITY ASSURANCE

- A. Testing and Inspection Agency Qualifications: A testing and inspection agency must have a minimum 5 years continuing experience preceding date of these Contract Documents, and be qualified in accordance with the following American Society for Testing and Materials (ASTM) publications:
  - 1. ASTM E 548-84 Standard Practice for Generic Criteria for use in the Evaluation of Testing and Inspection Agencies.
  - 2. ASTM E 699-79 (1984) Standard Criteria for Evaluation of Agencies Involved in Testing, Quality Assurance, and Evaluating Building Components in Accordance with Test Methods Promulgated by ASTM Committee E-6.
- B. Testing Equipment: Calibrated at intervals with devices of accuracy traceable to either National Bureau of Standards or accepted values of natural physical constants.

## 1.3 INSPECTION AND TESTING PERSONNEL AND FACILITIES

- A. Inspector of Record:
  - 1. The Owner will employ one or more qualified Inspectors of Record, acceptable to the Local Building Department issuing Permits who will be employed continuously at the construction site, working under the

Owner Representative's general direction. The IOR(s) will observe progress of the work and to report to the Owner any non-conformance with Contract Documents.

2. In compliance with the State Building Code, Part 1, Title 24 of the California Code of Regulations, Article 7-145, the Inspector of Record shall have personal knowledge, obtained by continuous inspection of all parts of the work of construction in all stages of its progress, to ensure that the work is in accordance with the approved contract documents.
3. Specific duties and limits of responsibilities include the following:
  - a. Observing and spot checking materials upon arrival at site, and work in progress, to determine conformance with Contract Documents. Reporting any defects immediately to the Owner.
  - b. Maintaining liaison with the Contractor and his Subcontractors only through Contractor's superintendent.
  - c. Evaluating Contractor's suggestions and reporting them with recommendations to the Owner for final decision.
  - d. Remaining alert to the Construction Schedule and immediately reporting any potential delays and problems to the Owner.
  - e. Maintaining a Daily Log of activities on site, pertinent to a continuous project report record.
  - f. Preparing a Verified Report every 3 months (or sooner if required for a specific project schedule).
  - g. Receiving Samples of construction materials at the jobsite.
  - h. Scheduling and accompanying regulatory inspectors through the project and reporting to the Owner the results of such inspection visits.
  - i. Being alert to conditions which could affect Hospital's existing operation.
  - j. Reviewing and verifying degree of work completion with that cited in Contractor's monthly payment request.
  - k. Maintaining Contract information and Shop Drawing files.
  - l. Preparing a Field Inspection Report of incomplete or unsatisfactory work at intervals throughout the work progress. Checking off such items when made complete and satisfactory by Contractor.
  - m. Attending project meetings in accordance with specifications Section 013100.

- n. Enforcing Infection Control requirements.
  - o. Provide all coordination for independent Testing Laboratories.
  - p. Participate in formation of Final Punch List.
- B. Local Permit Issuing Agency will approve the Inspector of Record for the project who shall be allowed access to the project site at any time.
- C. Geotechnical Engineer: Observation of all excavations and engineering control of all fills and backfills shall be by a Geotechnical Engineer.
- 1. Owner will contract with the Geotechnical Engineer for observation and testing of all excavations and engineering control of all fills and backfills.
  - 2. The Geotechnical Engineer shall submit a Final Report verifying that Work has been performed in accordance with the requirements of the Contract Documents and Soils Investigation Report(s) prepared for this Project.
  - 3. The Geotechnical Engineer shall distribute the Final Report in accordance with Paragraph 1.4, B.
- D. Testing and Inspection Agency:
- 1. The Owner will employ and pay for the services of an independent testing and inspection agency to perform the tests and inspections required herein except where noted otherwise.
    - a. Employment of the testing and inspection agency shall in no way relieve the Contractor's obligation to perform the work defined in the Contract Documents.
  - 2. Limitations of authority of the Testing and Inspection Agency:
    - a. Testing Agency is not authorized to:
      - 1) Release, revoke, alter, or enlarge on the requirements of the Contract Documents;
      - 2) Approve or accept any portion of the Work, or;
      - 3) Perform any duties of the Contractor.
  - 3. All work shall conform to the requirements of state and local applicable Codes.

4. Testing and inspection agency shall perform tests and inspections as required by applicable regulation as indicated in the specification Sections, and as directed by the Owner and required by the Code.
5. Testing and inspection agency shall prepare, cure, store, and transport job samples to the Laboratory.
6. At the completion of the Project, verified reports shall be submitted as required by CCR, Title 22 and as directed.

#### 1.4 LABORATORY REPORTS

- A. After each inspection and test, promptly submit copies of laboratory report which includes:
  1. Date issued,
  2. Project title and number,
  3. Name of Inspector from inspection agency,
  4. Date and time of sampling or inspection,
  5. Identification of product and specifications section,
  6. Location in the Project,
  7. Type of inspection or test,
  8. Date of test,
  9. Results of tests,
  10. Conformance with Contract Documents,
  11. Whether original test or re-test,
  12. State/local permit number,
- B. Reports shall be distributed to the following:
  1. Architect of Record
  2. Inspector of Record (I.O.R.)
  3. General Contractor
  4. Owner.
  5. Applicable Consultant
  6. Local Jurisdiction where applicable

## 1.5 LABORATORY RESPONSIBILITIES

- A. Provide qualified personnel at site. Cooperate with Architect/Inspector of Record and Contractor in performance of services.
- B. Perform specified inspecting, sampling, and testing of Products in accordance with specified standards.
- C. Ascertain compliance of materials and mixes with requirements of Contract Documents.
- D. Promptly notify Architect, IOR and Contractor of observed irregularities or non-conformance of Work or Products.
- E. Perform additional inspection and test required by Architect.
- F. Attend preconstruction meetings and progress meetings when requested.

## 1.6 CONTRACTOR'S RESPONSIBILITIES

- A. Cooperate with Inspector of Record and Testing and Inspection Agency and provide access to Work, including off-site manufacturer's or fabricator's operations.
  - 1. Provide required quantities of material samples to be tested.
  - 2. Samples will be selected and taken by representative of Testing and Inspection Agency.
- B. Furnish copies of product data and test reports as required.
- C. Furnish incidental labor and facilities:
  - 1. To provide access to work to be tested;
  - 2. To obtain and handle samples at the Project site, or at the source of the Product to be tested or inspected;
  - 3. To facilitate inspections and tests, and;
  - 4. For storage and curing of test samples at the Project site.
- D. Provide, on a weekly basis, a Short Interval Project Schedule with a minimum three-week duration which identifies upcoming testing requirements.
- E. Schedule the tests and inspections required by the Contract Documents and applicable codes and regulations with the Inspector of Record and the Testing and Inspection Agency, a minimum of 48 hours in advance.
  - 1. When tests or inspections cannot be performed after such notice, or if re-tests and re-inspections are required due to the fault of the Contractor, all costs for such re-work shall be deducted from the Contract Amount. If the remaining unpaid balance in the Contract is ins

ufficient to cover the Change Order for this work, Contractor shall pay the difference directly to the Owner.

2. Do not cover corrected Work until said Work has been re-tested and or re-inspected satisfactorily.
- F. Arrange with Owner's Testing and Inspection Agency and pay for additional samples and tests required for the Contractor's convenience when approved by Owner.
- G. Contractor shall pay costs for the following specified items:
1. Design mixes for:
    - a. Cast-in-Place concrete
    - b. Asphalt paving
  2. Redesign of mixes due to change in source of ingredients.
  3. Certified mill test reports.
  4. Pre-construction tests for masonry units.
  5. Preparation and delivery to laboratory of pre-construction masonry prisms for testing.
- H. Notification of Architect:
1. In addition to tests and inspections called for in this Section, notify applicable parties of inspections and testing called for in the individual Sections of the Specifications or on the Drawings.
  2. Notify 48 hours in advance, to assure inspections prior to covering up or closing in of work involved. Any work covered up before such required inspection or testing shall be uncovered or removed at the Contractor's expense.

PART 2 – PRODUCTS (Not Used)

PART 3 – EXECUTION (Not Used)

END OF SECTION

**SECTION 014373  
SCHEDULE OF VALUES**

**NAME OF BIDDER:** \_\_\_\_\_

**DATE:** \_\_\_\_\_

<b>DIV</b>	<b>TITLE</b>	<b>AMOUNT</b>	<b>\$/SQ. FT</b>	<b>COMMENTS</b>
01	General Conditions	\$ _____	\$ _____	
02	Demolition	\$ _____	\$ _____	
02	Saw cut slab	\$ _____	\$ _____	
03	Concrete	\$ _____	\$ _____	
04	Masonry	\$ _____	\$ _____	
05	Steel	\$ _____	\$ _____	
06	Woods and Plastics	\$ _____	\$ _____	
07	Thermal and Moisture Protection	\$ _____	\$ _____	
08	Openings	\$ _____	\$ _____	
09	Finishes	\$ _____	\$ _____	
10	Specialties	\$ _____	\$ _____	
12	Furnishings	\$ _____	\$ _____	
21	Fire Suppression	\$ _____	\$ _____	
22	Plumbing	\$ _____	\$ _____	
23	HVAC	\$ _____	\$ _____	
26	Electrical	\$ _____	\$ _____	
31	Earthwork	\$ _____	\$ _____	
32	Landscape	\$ _____	\$ _____	
33	Utilities	\$ _____	\$ _____	
	<b>SUBTOTAL</b>	\$ _____	\$ _____	
	<b>OVERHEAD AND PROFIT</b>	\$ _____	\$ _____	
	<b>TOTAL COST</b>	\$ _____	\$ _____	

**END OF SECTION**

**SECTION 015000 - TEMPORARY FACILITIES AND CONTROLS**

## PART 1 - GENERAL

## 1.1 RELATED DOCUMENTS

- A. Drawings and general provisions of the Contract, including General and Supplementary Conditions and other Division 1 Specification Sections, apply to this Section.

## 1.2 SUMMARY

- A. This Section includes requirements for temporary utilities, support facilities, and security and protection facilities.

## 1.3 USE CHARGES

- A. General: Cost or use charges for temporary facilities shall be included in the Contract Sum. Allow other entities to use temporary services and facilities without cost.
- B. Water Service: Pay water service use charges for water used by all entities for construction operations.
- C. Electric Power Service: Pay electric power service use charges for electricity used by all entities for construction operations.

## 1.4 QUALITY ASSURANCE

- A. Electric Service: Comply with NECA, NEMA, and UL standards and regulations for temporary electric service. Install service to comply with NFPA 70.

## PART 2 - PRODUCTS

## 2.1 MATERIALS

## 2.2 TEMPORARY FACILITIES

- A. Field Offices, General: Prefabricated or mobile units with serviceable finishes, temperature controls, and foundations adequate for normal loading.
- B. Common-Use Field Office: Of sufficient size to accommodate needs of construction personnel. Keep office clean and orderly. Furnish and equip offices as follows:
  - 1. Furniture required for Project-site documents including file cabinets, plan tables, plan racks, and bookcases.
  - 2. Heating and cooling equipment necessary to maintain a uniform indoor temperature of 68 to 72 deg F.



3. Lighting fixtures capable of maintaining average illumination of 20 fc at desk height.

## 2.3 EQUIPMENT

- A. Fire Extinguishers: Portable, UL rated; with class and extinguishing agent as required by locations and classes of fire exposures.
- B. Heating Equipment: Unless Owner authorizes use of permanent heating system, provide vented, self-contained, liquid-propane-gas or fuel-oil heaters with individual space thermostatic control.

## PART 3 - EXECUTION

### 3.1 INSTALLATION, GENERAL

- A. Locate facilities where they will serve Project adequately and result in minimum interference with performance of the Work. Relocate and modify facilities as required by progress of the Work.
- B. Provide each facility ready for use when needed to avoid delay. Do not remove until facilities are no longer needed or are replaced by authorized use of completed permanent facilities.

### 3.2 TEMPORARY UTILITY INSTALLATION

- A. General: Install temporary service or connect to existing service.
  1. Arrange with utility company, Owner, and existing users for time when service can be interrupted, if necessary, to make connections for temporary services.
- B. Water Service: Install water service and distribution piping in sizes and pressures adequate for construction.
- C. Sanitary Facilities: Provide temporary toilets, wash facilities, and drinking water for use of construction personnel. Comply with authorities having jurisdiction for type, number, location, operation, and maintenance of fixtures and facilities.
- D. Heating: Provide temporary heating required by construction activities for curing or drying of completed installations or for protecting installed construction from adverse effects of low temperatures or high humidity. Select equipment that will not have a harmful effect on completed installations or elements being installed.
- E. Electric Power Service: Provide electric power service and distribution system of sufficient size, capacity, and power characteristics required for construction operations.
- F. Lighting: Provide temporary lighting with local switching that provides adequate illumination for construction operations, observations, inspections, and traffic conditions.

- G. Telephone Service: Provide temporary telephone service in common-use facilities for use by all construction personnel. Install one telephone line(s) for each field office.
- H. Traffic Controls: Comply with requirements of authorities having jurisdiction.
  - 1. Protect existing site improvements to remain including curbs, pavement, and utilities.
  - 2. Maintain access for fire-fighting equipment and access to fire hydrants.
- I. Parking: Provide temporary parking areas for construction personnel.
- J. Dewatering Facilities and Drains: Comply with requirements of authorities having jurisdiction. Maintain Project site, excavations, and construction free of water.
  - 1. Dispose of rainwater in a lawful manner that will not result in flooding Project or adjoining properties nor endanger permanent Work or temporary facilities.
  - 2. Remove snow and ice as required to minimize accumulations.
- K. Project Identification and Temporary Signs: Provide Project identification sign. Install signs where indicated to inform public and individuals seeking entrance to Project. Unauthorized signs are not permitted.
- L. Waste Disposal Facilities: Provide waste-collection containers in sizes adequate to handle waste from construction operations. Comply with requirements of authorities having jurisdiction. Comply with Division 1 Section "Cleaning" for progress cleaning requirements.
- M. Temporary Stairs: Until permanent stairs are available, provide temporary stairs where ladders are not adequate.

### 3.3 SECURITY AND PROTECTION FACILITIES INSTALLATION

- A. Environmental Protection: Provide protection, operate temporary facilities, and conduct construction in ways and by methods that comply with environmental regulations and that minimize possible air, waterway, and subsoil contamination or pollution or other undesirable effects.
- B. Temporary Erosion and Sedimentation Control: Provide measures to prevent soil erosion and discharge of soil-bearing water runoff and airborne dust to adjacent properties and walkways, according to requirements of authorities having jurisdiction.
  - 1. Inspect, repair, and maintain erosion- and sedimentation-control measures during construction until permanent vegetation has been established.
- C. Stormwater Control: Comply with authorities having jurisdiction. Provide barriers in and around excavations and subgrade construction to prevent flooding by runoff of stormwater from heavy rains.
- D. Site Enclosure Fence: Before construction operations, furnish and install site enclosure fence in a manner that will prevent people and animals from easily entering site except by entrance gates.

- E. Barricades, Warning Signs, and Lights: Comply with requirements of authorities having jurisdiction for erecting structurally adequate barricades, including warning signs and lighting.
- F. Temporary Fire Protection: Install and maintain temporary fire-protection facilities of types needed to protect against reasonably predictable and controllable fire losses. Comply with NFPA 241.
  - 1. Supervise welding operations, combustion-type temporary heating units, and similar sources of fire ignition according to requirements of authorities having jurisdiction.
  - 2. Develop and supervise an overall fire-prevention and -protection program for personnel at Project site. Review needs with local fire department and establish procedures to be followed. Instruct personnel in methods and procedures. Post warnings and information.

### 3.4 OPERATION, TERMINATION, AND REMOVAL

- A. Maintenance: Maintain facilities in good operating condition until removal.
  - 1. Maintain operation of temporary enclosures, heating, cooling, humidity control, ventilation, and similar facilities on a 24-hour basis where required to achieve indicated results and to avoid possibility of damage.
- B. Termination and Removal: Remove each temporary facility when need for its service has ended, when it has been replaced by authorized use of a permanent facility, or no later than Substantial Completion. Complete or, if necessary, restore permanent construction that may have been delayed because of interference with temporary facility. Repair damaged Work, clean exposed surfaces, and replace construction that cannot be satisfactorily repaired.

END OF SECTION

**SECTION 016000- PRODUCT REQUIREMENTS**

## PART 1 - GENERAL

## 1.1 SUMMARY

- A. Work Included: This Section contains definitions, product requirements and requirements for prior approved items.
- B. Delivery and storage of materials and equipment.
- C. Procedures for selecting products and approving substitutions.

## 1.2 DEFINITIONS

- A. General: Definitions are not intended to negate the meaning of other terms used in Contract Documents, including specialties, systems, structure, finishes, accessories, furnishings, special construction, and similar terms, which are self-explanatory and have recognized meanings in the construction industry.
- B. Products: Purchased items for incorporation into the Work, regardless of whether specifically purchased for Project or taken from Contractor's stock of previously purchased products.
- C. Materials: Products which must be substantially cut, shaped, worked, mixed, finished, refined, or otherwise fabricated, processed, installed, or applied to form units of Work.
- D. Appliances, Equipment, and Fixtures: Products with operational parts, regardless of whether motorized or manually operated and particularly including products with service connections (wiring, piping, etc.).
- E. System: A unit of Work (i.e., structural system, vacuum system, etc.) shown or specified to include particular products, materials, appliances, equipment, or fixtures.
- F. Substitutions: Where products, materials, appliances, equipment, or fixtures are listed by trade name(s), manufacturer name(s), or catalog reference(s) or where these items are shown or specified as part of a system or systems, items or systems proposed for use by Contractor that are not listed or differ from those shown or specified as part of a system will be considered substitutions.
  - 1. Submit substitutions in accordance with requirements of this Section.
  - 2. The requirements for substitutions do not apply to specified Contractor options. Revisions to Contract Documents, where requested by Owner or Architect are changes, not substitutions.
  - 3. Contractor's determinations of and compliance with governing regulations and orders issued by governing authorities do not constitute substitutions, and do not constitute a basis for change orders; except as provided for under substitution procedures in this Section or elsewhere in Con

tract Documents.

- G. Prior -to-Bid Approvals: Products, materials, appliances, equipment, fixtures, or systems that have been proposed as substitutions and accepted by Owner prior to bid.

### 1.3 DESCRIPTION

- A. General: Specific products, materials, appliances, equipment, fixtures, accessories, manufacturers, and proprietary mentioned by name, grade, or brand, in Specifications or on Drawings have been selected for their particular fitness, availability, and desirability for use appropriate to Work of this Project and are intended to establish the standard of quality.
- B. Compliance: The compliance requirements, for individual products are multiple in nature and may include generic, descriptive, proprietary, performance, prescriptive, compliance with standards, compliance with codes, conformance with graphic details, and other similar forms and methods of indicating requirements.

### 1.4 PRODUCT REQUIREMENTS

- A. General: Provide products which comply with requirements, and which are undamaged and unused at time of installation, and which are complete with accessories, trim, finish, safety guards, and other devices and details needed for a complete installation and for intended use.
  - 1. Materials shall be new unless otherwise specified and unused, except for testing of current production models on date of order, undamaged, and un-deteriorated at time of use.
  - 2. Identify materials in accordance with accepted trade standards and requirements of this Section.
  - 3. Select and use methods or processes, including intermediate processes, which will produce the specified finished material or product.
  - 4. Ascertain that the Work, including materials, products, and equipment delivered and installed, is in full compliance with the Contract Documents and appropriate submittals.
  - 5. Standard Products: Where available, provide standard products of types which have been produced and used previously and successfully on other projects and in similar applications.
  - 6. Continued Availability: Where additional amounts of product, by nature of its application, are likely to be needed by Owner at a later date for maintenance and repair or replacement work, provide a standard, domestically produced product which is likely to be available to Owner at such later date.
- B. Nameplates: Except as otherwise indicated for required approval labels and operating data, do not permanently attach or imprint manufacturer's or produ

cer's nameplates or trademarks on exposed surfaces of products which will be exposed to view either in occupied spaces or on exterior of the Work.

1. Labels: Locate required labels and stamps on a concealed surface or, where required for observation after installation, on an accessible surface which, in occupied spaces, is not conspicuous.
2. Equipment Nameplates: Provide permanent nameplate on each item of service-connected or power-operated equipment. See sections specifying equipment requirements for specifics.

#### 1.5 QUALITY ASSURANCE

- A. Special Requirement: Due to certain Owner requirements, Owner will not consider substitutions on certain items. Therefore, substitutions will not be considered for items followed by the words: "no substitution(s)."
- B. Architect's Compensation:
  1. Except as limited by provisions of Owner-Architect or Owner-Contractor Agreements, Contractor shall reimburse Owner for compensation paid to Architect for evaluation of substitution proposals made during construction, whether or not substitution is accepted by Owner.
  2. Refer to Request for Substitution form at the end of this Section.
- C. Delays and Costs:
  1. Substitution proposals made during construction shall be in accordance with procedures outlined in this Section, and be made in sufficient time to allow for adequate time for Architect's review and evaluation.
  2. Delays and added costs associated with inadequate supportive data, necessary extended evaluations, or redesign work caused by substitutions shall be borne by Contractor.
  3. Cost changes resulting from proposed substitutions shall be clearly stated with the initial substitution proposal. Subsequently discovered costs resulting from the substitution shall be borne by Contractor.

#### 1.6 TRANSPORTATION AND HANDLING

- A. Transport products by methods to avoid product damage; deliver in undamaged condition in manufacturer's unopened containers or packaging, dry.
- B. Provide equipment and personnel to handle products by methods to prevent soiling or damage.
- C. Promptly inspect shipments to assure that products comply with requirements, quantities are correct, and products are undamaged.
- D. Deliver products in the manufacturer's sealed container or other packaging

system, complete with labels and instructions for handling, storing, unpacking, protecting and installing.

#### 1.7 STORAGE AND PROTECTION

- A. Store Products in accordance with manufacturer's instructions, with seals and labels intact and legible.
- B. Store sensitive products in weathertight enclosures; maintain within temperature and humidity ranges required by manufacturer's instructions.
- C. For exterior storage of fabricated products, place on sloped supports above ground. Cover products subject to deterioration with impervious sheet covering; provide ventilation to avoid condensation.
- D. Store loose granular materials on solid surfaces in a well-drained area; prevent mixing with foreign matter.
- E. Arrange storage to provide access for inspection, periodically inspect to assure products are undamaged and are maintained under required conditions.
- F. After installation, provide covering to protect products from damage from traffic and construction operations, remove when no longer needed.

#### 1.8 PROCEDURES

- A. Procedures for Selecting Products: Contractor's options for selecting products are limited by Contract Document requirements and governing regulations, and are not controlled by industry traditions or procedures experienced by Contractor on previous construction projects.
  - 1. Single Product/Manufacturer Name:
    - a. Provide product indicated. Do not offer to provide an unnamed product unless it has been accepted under substitution provisions listed below.
    - b. Except as otherwise indicated, "Named" is defined to mean manufacturer's name for product as recorded in latest issue of published product literature as of date of Contract Documents.
    - c. Refer to requests to use products of a later (or earlier) model to Architect for acceptance before proceeding.
  - 2. Two or More Product/Manufacturer Names:
    - a. Provide 1 of the named products, at Contractor's option.
    - b. Do not offer to provide an unnamed product unless it has been accepted under substitution provisions listed below.
  - 3. Performance Requirements:

- a. Provide products which comply with specific performances indicated and which are recommended by manufacturer (in published product literature or by individual certification) for application indicated.
  - b. Overall performance of a product is implied where product is specified for specific performances.
4. Standards, Codes, and Regulations: Where compliance with an imposed standard, code, or regulation is required, selection from among products which comply with requirements of those standards, codes, and regulations is Contractor's option.
  5. Prescriptive Requirements: Provide products which have been produced in accordance with prescriptive requirements, using specified ingredients and components, and complying with specified requirements for mixing, fabricating, curing, finishing, testing, and similar operations in manufacturing process.
  6. Visual Matching:
    - a. Where matching of an established sample is required, final judgment of whether a product proposed by Contractor matches sample satisfactorily is Architect's judgment.
    - b. Where no product exists within specified cost category, which matches sample satisfactorily and complies with requirements, comply with provisions concerning, substitutions and change orders for selection of an equivalent product.
  7. Visual Selection:
    - a. Where specified product requirements include "color(s), pattern(s), texture(s), etc. selected by Architect" or words of similar effect, selection of manufacturer and basic product (complying with requirements) is Contractor's option, and subsequent selection of color(s), pattern(s), and texture(s), etc. is Architect's selection.
    - b. Where specified product requirements include "color(s), pattern(s), texture(s), etc., to match Architect's sample" or words to that effect, selection of product (complying with requirements, and within established cost category) is Architect's selection, including designation of manufacturer where necessary to obtain desired color, pattern, or texture.

#### 1.9 SUBSTITUTION PROCEDURES

- A. Prior (-to-Bid) Approvals: Substitute products, materials, appliances, equipment, fixtures, or systems will be considered by Architect.
  1. Any bidder, material supplier, or manufacturer desiring to propose substitution(s) shall:



- a. Submit in a sealed envelope catalog cuts, shop drawings, or other descriptive literature for products, materials, appliances, equipment, fixtures, or systems for proposed substitution.
  - b. Submit not later than 14 calendar days before bid opening
1. Make request to Architect in triplicate on copies of Request for Substitution form included at end of this Section.
  2. Submittal(s) shall include a complete and adequate analysis showing point-for-point comparison to specified item(s) or system(s) and must prove equality or superiority.
  3. Include related Section and Drawing number(s), and fully document compliance with requirements for substitutions.
  4. Include product data/drawings, description of methods, samples.
    - a. Where applicable, statement of effect on construction time and coordination with other affected Work.
    - b. Cost information for proposal.
  5. Include identification of previous use locally with dates and names of Architect and Owner.
  6. Anything less will not be considered.
  7. Equivalency:
    - a. The Architect will be the initial judge of equivalency of proposed substitution(s).
    - b. Architect will make written recommendation of acceptance or rejection to Owner.
  8. Satisfaction:
    - a. Prior to proposing substitution(s), certify that item or system is equal to that specified.
    - b. That it will fit into space allocated.
    - c. That item affords comparable ease of operation, maintenance, and service.
    - d. That appearance, longevity, and suitability for climate and use are comparable to item specified.
    - e. That substitution is in Owner's interest.
  9. Manufacturer's data which is readily available to Architect is not acceptable for establishing proof of quality.

- a. Provide laboratory test data performed by a nationally recognized independent testing laboratory known for its testing expertise.
  - b. Laboratory test shall include types of materials used in substitute item or system, including their thickness and strength, and a direct comparison to item or system specified for capacities, capabilities, coatings, functions, life cycle usage, and operations.
  - c. No change in Architect's design intent will be allowed where item or system will be exposed and where it will be used.
10. Proof: Burden of proof that a proposed substitution is equal or equivalent to a specified item or system shall be upon Contractor, who shall support his request with sufficient test data, samples, brochures, and other means to permit Architect to make a fair and equitable decision on merits of proposal.
  11. Based on Architect's written recommendation of acceptance or rejection, Owner will determine acceptability of proposed substitutions.
  12. Architect will notify Bidders of Owner's acceptance not later than 5 calendar days prior to bid opening via an addendum to the Contract Documents listing only accepted substitutions.
  13. Responsibility: Acceptance of substitutions shall not relieve Contractor from responsibility for complying with all other requirements of the Contract Documents and coordinating substitution(s) with adjacent materials and other affected equipment.
- B. During Construction:
1. Substitutions will not be considered when they are indicated or implied on submittals without separate written request prior to submittal, or when acceptance will require substantial revision of Contract Documents.
  2. Architect and Owner will consider requests from Contractor during construction for substitutions (following procedures outlined above for prior approvals) only under 1 or more of the following conditions:
    - a. Substitution is required for compliance with subsequent interpretation of code requirements or insurance regulations.
    - b. Shown or specified item or system cannot be provided within Contract Time or becomes unavailable due to no fault of Contractor.
    - c. Subsequent information disclosed inability of item(s) or system(s) to perform properly or to fit in designated space, or manufacturer(s) refuse(s) to certify or warrant performance as required.
    - d. When, in Architect's judgment, a substitution would be substantially in Owner's best interests in terms of cost (substantial credit), time, or other valuable considerations, after deducting offsetting responsibilities Owner may be required to bear, including additional compensation to Architect for evaluation and redesign ser

vices, increased cost of other work by Owner or separate contractors, and similar considerations.

PART 2 - PRODUCTS  
Not used.

PART 3 - EXECUTION  
Not used.

END OF SECTION

REQUEST FOR SUBSTITUTION

A. Completed reproduction of this form shall accompany all requests for substitutions. Failure to submit form with request shall be cause for rejection. Substituted items or systems may be incorporated into the Work only after receipt of Owner's written approval. Fill in all applicable spaces and cross out all nonapplicable information bracketed ([]) or unbracketed.

[Subcontractor:] [Material Supplier:] [Manufacturer:] Date:  
Requested Substitution:  
Reference: Specification Section \_\_\_\_\_ Drawing Reference \_\_\_\_\_  
Reason for Substitution: [Prior Approval] [During Construction]:

B. Resulting Change to Contract Amount: [Add] [Deduct] \_\_\_\_\_  
(Include supporting documentation.)

C. For substitutions made during construction the Architect will, upon receipt of substitution proposal, fill in the following compensation information, add it to or deduct it from the Change to the Contract Amount and submit Net Change to Contract Amount to Owner for approval. Upon receipt of Owner's approval, Architect will proceed with substitution review.

D. Architect's Fee for Substitution Evaluation: \_\_\_\_\_

E. Architect's Fee for Changes to Contract: \_\_\_\_\_

F. Documents Due to Substitution:  
Net Change to Contract Amount (B + C + D): [Add] [Deduct]  
Resulting Change to Contract Time: Add \_\_\_\_\_ Deduct \_\_\_\_\_  
Summary of Related Work Requiring Coordination (if any): \_\_\_\_\_

(Contractor shall assume responsibility for complete coordination with Work of all trades involved if Substitution Request is approved.)

G. Attached Documentation: The following is herewith attached to provide complete documentation of requested substitution:

[ ] Product Data [ ] Samples [ ] Shop Drawings  
[ ] Test Reports [ ] Other:

H. Contractor's Signature

Subcontractor's/Supplier's/Manufacturer's  
Signature

**SECTION 017600 – GUARANTIES AND WARRANTIES**

## PART 1 - GENERAL

## 1.1 SUMMARY

- A. This Section includes requirements for guaranties and warranties for contract closeout and during specified guaranty/warranty periods.

## 1.2 DESCRIPTION OF REQUIREMENTS

- A. General Limitations: It is recognized that specific guaranties and warranties are intended to protect Owner against failure of the Work to perform as required, and against deficient, defective, and faulty materials and workmanship, regardless of sources.
- B. Related Damages and Losses: When correcting guarantied or warranted work which has failed, remove and replace other Work of Project which has been damaged as a result of such failure or which must be removed and replaced to provide access for correction of Work.
- C. Reinstatement of Guaranty or Warranty Period: In addition to requirements in the General Conditions, when Work covered by a special project guaranty or product warranty has failed and has been corrected by replacement or restoration, reinstate guaranty or warranty by written endorsement for 1 year starting on date of acceptance of replaced or restored Work.
- D. Replacement Cost, Obligations: Except as otherwise indicated, cost of replacing or restoring failing guaranties or warranted units or products is Contractor's obligation, without regard for whether Owner has already benefitted from use through a portion of anticipated useful service lives.
- E. Rejection of Warranties: Owner reserves the right, at time of Substantial Completion or thereafter, to reject coincidental product warranties submitted by Contractor, which in opinion of Owner detract from or confuse interpretation of requirements of Contract Documents.
- F. Contractor's Procurement Obligations: Do not purchase, subcontract for, or allow others to purchase or subcontract for materials or units of Work for Project where a special project guaranty, specified product warranty, certification, or similar commitment is required until it has been determined that entities required to sign or countersign such commitments are willing to do so.
- G. Specific Guaranty or Warranty Forms: Where a special project guaranty or specified project warranty is required, prepare a written document to contain terms and appropriate identification; ready for execution by required parties.
  - 1. A sample form is attached as the last article of this Section.
  - 2. Refer to individual sections of Divisions 2 through 33 for specific content and requirements.
  - 3. Submit draft to Owner for approval prior to final executions.

## 1.3 REQUIREMENTS INCLUDED

- A. Compile specified warranties.
- B. Compile specified service and maintenance contracts.
- C. Co-execute submittals when so specified.
- D. Review submittals to verify compliance with Contract Documents.
- E. Submit to Architect for review and transmittal to Owner.

## 1.4 SUBMITTAL REQUIREMENTS

- A. Assemble warranties, bonds, and service and maintenance contracts, executed by each of the respective manufacturers, suppliers, and subcontractors.
- B. Number of original signed copies required: 2 each.
- C. Table of Contents: Neatly typed, in orderly sequence. Provide complete index information for each item.
  - 1. Product or work item with index number to bound item.
  - 2. Firm, with name of principal, address, and telephone number.
  - 3. Scope.
  - 4. Date of beginning of warranty, bond or service and maintenance contract.
  - 5. Duration of warranty, bond, or service maintenance contract.
  - 6. Provide information for Owner's personnel:
    - a. Procedure to be followed in case of failure.
    - b. Circumstances which might affect the validity of warranty or bond.
  - 7. Contractor, name of responsible principal, address and telephone number.

## 1.5 FORM OF SUBMITTALS

- A. Prepare in duplicate packets.
- B. Format:
  - 1. Size 8-1/2 x 11 inches on punched sheets for standard 3-ring binder.
    - a. Fold larger sheets to fit into binders.
  - 2. Warranty-Guaranty wording shall be as printed below.
  - 3. Cover: Identify each packet with typed or printed title "GUARANTIES AND WARRANTIES". List:

- a. Title of Project.
- b. Name of Contractor.
- C. Binders: Commercial quality, 3-ring, with durable and cleanable plastic covers.

1.6 TIME OF SUBMITTALS

- A. Make submittals within 10 days after date of Substantial Completion prior to final request for payment.
- B. For items or work, where acceptance is delayed materially beyond Date of Substantial Completion, provide updated submittal within 10 days after acceptance, listing date of acceptance as start of warranty period.

1.7 SUBMITTALS REQUIRED

- A. Submit warranties, bonds, service and maintenance contracts as specified in respective Sections of Specifications and as follows:
  - 1. Provide when noted in individual Sections of the Project Manual Divisions 2 through 33.

1.8 SAMPLE FORM OF WARRANTY-GUARANTY

- A. Print or type Warranty-Guaranty on installing contractor's own letterhead.
- B. Wording and signatures required.

PART 2 - PRODUCTS

Not used.

PART 3 - EXECUTION

Not used.

END OF SECTION

A. GUARANTEE-WARRANTY

When required by the specifications, warranties and/or guarantees other than one year shall be in the form of the following on the Contractor's own letterhead:

"GUARANTEE-WARRANTY FOR INTERMOUNTAIN HEALTHCARE, McKay Dee Hospital Pulmonary Clinic Remodel project.

We hereby warrant and the General Contractor and/or Material Manufacturer guarantee that the (name of product, equipment or system) that we have installed in the 'McKay Dee Hospital Pulmonary Clinic Remodel project, has been done in accordance with the Contract Documents and that the work as installed will fulfill the requirements of the guaranty-warranty included in the specifications. We agree to repair or replace any or all of our work, together with any other adjacent work which may be displaced by so doing, that may prove to be defective in its workmanship or material within a period of \_\_\_\_\_ years from the date of Substantial Completion, without any expense whatsoever to the Owner, ordinary wear and tear and unusual abuse or neglect excepted.

In the event of our failure to comply with the above mentioned conditions within sixty (60) days after being notified in writing by the Owner, we collectively or separately do hereby authorize the Owner to proceed to have said defects repaired and made good at our expense, and we will honor and pay the costs and charges therefore upon demand.

Signed \_\_\_\_\_  
(Subcontractor)

Countersigned \_\_\_\_\_  
(General Contractor)

Name \_\_\_\_\_  
(Print)

Name \_\_\_\_\_  
(Print)

Company \_\_\_\_\_

Company \_\_\_\_\_

Address \_\_\_\_\_

Address \_\_\_\_\_

License No. \_\_\_\_\_

License No. \_\_\_\_\_

Countersigned \_\_\_\_\_  
(Material Manufacturer)

Name \_\_\_\_\_

Company \_\_\_\_\_

Address \_\_\_\_\_



**SECTION 017700 - CLOSEOUT PROCEDURES**

## PART 1 - GENERAL

## 1.1 RELATED DOCUMENTS

- A. Drawings and general provisions of the Contract, including General and Supplementary Conditions and other Division 1 Specification Sections, apply to this Section.

## 1.2 SUMMARY

- A. This Section includes administrative and procedural requirements for contract closeout, including, but not limited to, the following:
  - 1. Inspection procedures.
  - 2. Record Documents
  - 3. Operation and Maintenance Manuals
  - 4. Warranties.
  - 5. Final cleaning.

## 1.3 SUBSTANTIAL COMPLETION

- A. Preliminary Procedures: Before requesting inspection for determining date of Substantial Completion, complete the following. List items below that are incomplete in request.
  - 1. Prepare a list of items to be completed and corrected (punch list), the value of items on the list, and reasons why the Work is not complete.
  - 2. Submit specific warranties, workmanship bonds, maintenance service agreements, final certifications, and similar documents.
  - 3. Prepare and submit Project Record Documents, operation and maintenance manuals and similar final record information.
  - 4. Deliver tools, spare parts, extra materials, and similar items to location designated by Owner. Label with manufacturer's name and model number where applicable.
  - 5. Complete startup testing of systems.
  - 6. Submit test/adjust/balance records.
  - 7. Terminate and remove temporary facilities from Project site, along with mockups, construction tools, and similar elements.
  - 8. Complete final cleaning requirements, including touchup painting.
- B. Inspection: Submit a written request for inspection for Substantial Completion. On receipt of request, Architect will proceed with inspection. Architect will prepare the Certificate of Substantial Completion after inspection or will notify Contractor of items, either on Contractor's list or additional items identified by Architect that must be completed or corrected before certificate will be issued.
  - 1. Reinspection: Request reinspection when the Work identified in previous inspections as incomplete is completed or corrected.
  - 2. Results of completed inspection will form the basis of requirements for Final Completion.

#### 1.4 FINAL COMPLETION

- A. Preliminary Procedures: Before requesting final inspection for determining date of Final Completion, complete the following:
1. Submit a final Application for Payment according to Division 1 Section "Payment Procedures."
  2. Submit certified copy of Architect's Substantial Completion inspection list of items to be completed or corrected (punch list), endorsed and dated by Architect. The certified copy of the list shall state that each item has been completed or otherwise resolved for acceptance.
  3. Instruct Owner's personnel in operation, adjustment, and maintenance of products, equipment, and systems.

#### PART 2 - PRODUCTS

##### 2.1 MATERIALS

- A. Cleaning Agents: Use cleaning materials and agents recommended by manufacturer or fabricator of the surface to be cleaned. Do not use cleaning agents that are potentially hazardous to health or property or that might damage finished surfaces.

#### PART 3 - EXECUTION

##### 3.1 FINAL CLEANING

- A. General: Provide final cleaning. Conduct cleaning and waste-removal operations to comply with local laws and ordinances and Federal and local environmental and antipollution regulations.
- B. Cleaning: Employ experienced workers or professional cleaners for final cleaning. Clean each surface or unit to condition expected in an average commercial building cleaning and maintenance program. Comply with manufacturers written instructions.
1. Complete the following cleaning operations before requesting inspection for certification of Substantial Completion for entire Project or for a portion of Project:
    - a. Clean Project site, yard, and grounds, in areas disturbed by construction activities, including landscape development areas, of rubbish, waste material, litter, and other foreign substances.
    - b. Sweep paved areas broom clean. Remove petrochemical spills, stains, and other foreign deposits.
    - c. Rake grounds that are neither planted nor paved to a smooth, even-textured surface.
    - d. Remove tools, construction equipment, machinery, and surplus material from Project site.
    - e. Clean exposed exterior and interior hard-surfaced finishes to a dirt-free condition, free of stains, films, and similar foreign substances. Avoid disturbing natural weathering of exterior surfaces. Restore reflective surfaces to their original condition.

- f. Remove debris and surface dust from limited access spaces, including roofs, plenums, shafts, trenches, equipment vaults, manholes, attics, and similar spaces.
  - g. Sweep concrete floors broom clean in unoccupied spaces.
  - h. Vacuum carpet and similar soft surfaces, removing debris and excess nap; shampoo if visible soil or stains remain.
  - i. Clean transparent materials, including mirrors and glass in doors and windows. Remove glazing compounds and other noticeable, vision-obscuring materials. Replace chipped or broken glass and other damaged transparent materials. Polish mirrors and glass, taking care not to scratch surfaces.
  - j. Remove labels that are not permanent.
  - k. Touch up and otherwise repair and restore marred, exposed finishes and surfaces. Replace finishes and surfaces that cannot be satisfactorily repaired or restored or that already show evidence of repair or restoration.
    - 1) Do not paint over "UL" and similar labels, including mechanical and electrical nameplates.
  - l. Wipe surfaces of mechanical and electrical equipment, elevator equipment, and similar equipment. Remove excess lubrication, paint and mortar droppings, and other foreign substances.
  - m. Clean plumbing fixtures to a sanitary condition, free of stains, including stains resulting from water exposure.
  - n. Clean exposed surfaces of diffusers, registers, and grills.
  - o. Clean light fixtures, lamps, globes, and reflectors to function with full efficiency. Replace burned-out bulbs, and those noticeably dimmed by hours of use, and defective and noisy starters in fluorescent and mercury vapor fixtures to comply with requirements for new fixtures.
  - p. Leave Project clean and ready for occupancy.
- C. Comply with safety standards for cleaning. Do not burn waste materials. Do not bury debris or excess materials on Owner's property. Do not discharge volatile, harmful, or dangerous materials into drainage systems. Remove waste materials from Project site and dispose of lawfully.

END OF SECTION

**SECTION 017823 – OPERATION AND MAINTENANCE DATA**

## PART 1 - GENERAL

## PART 2 - RELATED DOCUMENTS

- A. Drawings and general provisions of the Contract, including General and Supplementary Conditions and other Division 1 Specification Sections, apply to this Section.

## 2.2 SUMMARY

- A. This Section includes administrative and procedural requirements for preparing operation and maintenance manuals, including the following:
  - 1. Operation and maintenance documentation directory.
  - 2. Emergency manuals.
  - 3. Operation manuals for systems, subsystems, and equipment.
  - 4. Maintenance manuals for the care and maintenance of products, materials, and finishes.
- B. Related Sections include the following:
  - 1. Division 1 Section "Submittal Procedures" for submitting copies of submittals for operation and maintenance manuals.
  - 2. Division 1 Section "Project Record Documents" for preparing Record Drawings for operation and maintenance manuals.
  - 3. Divisions 2 through 33 Sections for specific operation and maintenance manual requirements for the Work in those Sections.

## 2.3 DEFINITIONS

- A. System: An organized collection of parts, equipment, or subsystems united by regular interaction.
- B. Subsystem: A portion of a system with characteristics similar to a system.

## 2.4 SUBMITTALS

- A. Final Submittal: Submit one copy one of each manual in final form at least 15 days before final inspection. Architect will return copy with comments within 15 days after final inspection.
  - 1. Correct or modify each manual to comply with Architect's comments. Submit 3 copies of each corrected manual within 15 days of receipt of Architect's comments.

## 2.5 COORDINATION

- A. Where operation and maintenance documentation includes information on installations by more than one factory-authorized service representative, assemble and coordinate information furnished by representatives and prepare manuals.

## PART 3 - OPERATION AND MAINTENANCE DOCUMENTATION DIRECTORY

- A. Organization: Include a section in the directory for each of the following:
  - 1. List of documents.
  - 2. List of systems.
  - 3. List of equipment.
  - 4. Table of contents.
- B. List of Systems and Subsystems: List systems alphabetically. Include references to operation and maintenance manuals that contain information about each system.
- C. List of Equipment: List equipment for each system, organized alphabetically by system. For pieces of equipment not part of system, list alphabetically in separate list.
- D. Tables of Contents: Include a table of contents for each emergency, operation, and maintenance manual.
- E. Identification: In the documentation directory and in each operation and maintenance manual, identify each system, subsystem, and piece of equipment with same designation used in the Contract Documents. If no designation exists, assign a designation according to ASHRAE Guideline 4, "Preparation of Operating and Maintenance Documentation for Building Systems."

## 3.2 MANUALS, GENERAL

- A. Organization: Unless otherwise indicated, organize each manual into a separate section for each system and subsystem, and a separate section for each piece of equipment not part of a system. Each manual shall contain the following materials, in the order listed:
  - 1. Title page.
  - 2. Table of contents.
  - 3. Manual contents.
- B. Title Page: Enclose title page in transparent plastic sleeve. Include the following information:
  - 1. Subject matter included in manual.
  - 2. Name and address of Project.
  - 3. Name and address of Owner.
  - 4. Date of submittal.
  - 5. Name, address, and telephone number of Contractor.
  - 6. Cross-reference to related systems in other operation and maintenance manuals.

- C. Table of Contents: List each product included in manual, identified by product name, indexed to the content of the volume, and cross-referenced to Specification Section number in Project Manual.
  - 1. If operation or maintenance documentation requires more than one volume to accommodate data, include comprehensive table of contents for all volumes in each volume of the set.
  
- D. Manual Contents: Organize into sets of manageable size. Arrange contents alphabetically by system, subsystem, and equipment. If possible, assemble instructions for subsystems, equipment, and components of one system into a single binder.
  - 1. Binders/Maintenance Manuals: Organize operation and maintenance data into suitable sets of manageable size. Binders shall be Red Buckram binders with easy view metal for sheet size 11" X 8 ½" with expandable metal capacity as required for the project, rivet through construction with library corners using #12 BB and lining with same materials as cover, front cover and back-bone foil stamped in white. Binders shall be as manufactured by Hiller Bookbinding or equal. The master index sheet and each tabbed index sheet shall be AICO Gold-Line indexes or equal. Mark appropriate identification on front spine of each binder. Include the following types of information:
    - a. If two or more binders are necessary to accommodate data of a system, organize data in each binder into groupings by subsystem and related components. Cross-reference other binders if necessary to provide essential information for proper operation or maintenance of equipment or system.
    - b. Identify each binder on front and spine, with printed title "OPERATION AND MAINTENANCE MANUAL," Project title or name, and subject matter of contents. Indicate volume number for multiple-volume sets.
  - 2. Protective Plastic Sleeves: Transparent plastic sleeves designed to enclose diagnostic software diskettes for computerized electronic equipment.
  - 3. Drawings: Attach reinforced, punched binder tabs on drawings and bind with text.
    - a. If oversize drawings are necessary, fold drawings to same size as text pages and use as foldouts.
    - b. If drawings are too large to be used as foldouts, fold and place drawings in labeled envelopes and bind envelopes in rear of manual. At appropriate locations in manual, insert typewritten pages indicating drawing titles, descriptions of contents, and drawing locations.

### 3.3 EMERGENCY MANUALS

- A. Content: Organize manual into a separate section for each of the following:
  - 1. Type of emergency.
  - 2. Emergency instructions.
  - 3. Emergency procedures.

- B. Type of Emergency: Where applicable for each type of emergency indicated below, include instructions and procedures for each system, subsystem, piece of equipment, and component:
1. Fire.
  2. Flood.
  3. Gas leak.
  4. Water leak.
  5. Power failure.
  6. Water outage.
  7. System, subsystem, or equipment failure.
  8. Chemical release or spill.
- C. Emergency Instructions: Describe and explain warnings, trouble indications, error messages, and similar codes and signals. Include responsibilities of Owner's operating personnel for notification of Installer, supplier, and manufacturer to maintain warranties.
- D. Emergency Procedures: Include the following, as applicable:
1. Instructions on stopping.
  2. Shutdown instructions for each type of emergency.
  3. Operating instructions for conditions outside normal operating limits.
  4. Required sequences for electric or electronic systems.
  5. Special operating instructions and procedures.

### 3.4 OPERATION MANUALS

- A. Content: In addition to requirements in this Section, include operation data required in individual Specification Sections and the following information:
1. System, subsystem, and equipment descriptions.
  2. Performance and design criteria if Contractor is delegated design responsibility.
  3. Operating standards.
  4. Operating procedures.
  5. Operating logs.
  6. Wiring diagrams.
  7. Control diagrams.
  8. Piped system diagrams.
  9. Precautions against improper use.
  10. License requirements including inspection and renewal dates.
- B. Descriptions: Include the following:
1. Product name and model number.
  2. Manufacturer's name.
  3. Equipment identification with serial number of each component.
  4. Equipment function.
  5. Operating characteristics.
  6. Limiting conditions.
  7. Performance curves.
  8. Engineering data and tests.
  9. Complete nomenclature and number of replacement parts.

- C. Operating Procedures: Include the following, as applicable:
  - 1. Startup procedures.
  - 2. Equipment or system break-in procedures.
  - 3. Routine and normal operating instructions.
  - 4. Regulation and control procedures.
  - 5. Instructions on stopping.
  - 6. Normal shutdown instructions.
  - 7. Seasonal and weekend operating instructions.
  - 8. Required sequences for electric or electronic systems.
  - 9. Special operating instructions and procedures.
- D. Systems and Equipment Controls: Describe the sequence of operation, and diagram controls as installed.
- E. Piped Systems: Diagram piping as installed, and identify color-coding where required for identification.

### 3.5 PRODUCT MAINTENANCE MANUAL

- A. Content: Organize manual into a separate section for each product, material, and finish. Include source information, product information, maintenance procedures, repair materials and sources, and warranties and bonds, as described below.
- B. Source Information: List each product included in manual, identified by product name and arranged to match manual's table of contents. For each product, list name, address, and telephone number of Installer or supplier and maintenance service agent, and cross-reference Specification Section number and title in Project Manual.
- C. Product Information: Include the following, as applicable:
  - 1. Product name and model number.
  - 2. Manufacturer's name.
  - 3. Color, pattern, and texture.
  - 4. Material and chemical composition.
  - 5. Reordering information for specially manufactured products.
- D. Maintenance Procedures: Include manufacturer's written recommendations and the following:
  - 1. Inspection procedures.
  - 2. Types of cleaning agents to be used and methods of cleaning.
  - 3. List of cleaning agents and methods of cleaning detrimental to product.
  - 4. Schedule for routine cleaning and maintenance.
  - 5. Repair instructions.
- E. Repair Materials and Sources: Include lists of materials and local sources of materials and related services.
- F. Warranties and Bonds: Include copies of warranties and bonds and lists of circumstances and conditions that would affect validity of warranties or bonds.



1. Include procedures to follow and required notifications for warranty claims.

### 3.6 SYSTEMS AND EQUIPMENT MAINTENANCE MANUAL

- A. Content: For each system, subsystem, and piece of equipment not part of a system, include source information, manufacturers' maintenance documentation, maintenance procedures, maintenance and service schedules, spare parts list and source information, maintenance service contracts, and warranty and bond information, as described below.
- B. Source Information: List each system, subsystem, and piece of equipment included in manual, identified by product name and arranged to match manual's table of contents. For each product, list name, address, and telephone number of Installer or supplier and maintenance service agent, and cross-reference Specification Section number and title in Project Manual.
- C. Manufacturers' Maintenance Documentation: Manufacturers' maintenance documentation including the following information for each component part or piece of equipment:
  1. Standard printed maintenance instructions and bulletins.
  2. Drawings, diagrams, and instructions required for maintenance, including disassembly and component removal, replacement, and assembly.
  3. Identification and nomenclature of parts and components.
  4. List of items recommended to be stocked as spare parts.
- D. Maintenance Procedures: Include the following information and items that detail essential maintenance procedures:
  1. Test and inspection instructions.
  2. Troubleshooting guide.
  3. Precautions against improper maintenance.
  4. Aligning, adjusting, and checking instructions.
  5. Demonstration and training videotape, if available.
- E. Maintenance and Service Schedules: Include service and lubrication requirements, list of required lubricants for equipment, and separate schedules for preventive and routine maintenance and service with standard time allotment.
  1. Scheduled Maintenance and Service: Tabulate actions for daily, weekly, monthly, quarterly, semiannual, and annual frequencies.
  2. Maintenance and Service Record: Include manufacturers' forms for recording maintenance.
- F. Spare Parts List and Source Information: Include lists of replacement and repair parts, with parts identified and cross-referenced to manufacturers' maintenance documentation and local sources of maintenance materials and related services.
- G. Warranties and Bonds: Include copies of warranties and bonds and lists of circumstances and conditions that would affect validity of warranties or bonds.
  1. Include procedures to follow and required notifications for warranty claims.

## EXECUTION

## 3.7 MANUAL PREPARATION

- A. Emergency Manual: Assemble a complete set of emergency information indicating procedures for use by emergency personnel and by Owner's operating personnel for types of emergencies indicated.
- B. Product Maintenance Manual: Assemble a complete set of maintenance data indicating care and maintenance of each product, material, and finish incorporated into the Work.
- C. Operation and Maintenance Manuals: Assemble a complete set of operation and maintenance data indicating operation and maintenance of each system, subsystem, and piece of equipment not part of a system.
  - 1. Engage a factory-authorized service representative to assemble and prepare information for each system, subsystem, and piece of equipment not part of a system.
  - 2. Prepare a separate manual for each system and subsystem, in the form of an instructional manual for use by Owner's operating personnel.
- D. Manufacturers' Data: Where manuals contain manufacturers' standard printed data, include only sheets pertinent to product or component installed. Mark each sheet to identify each product or component incorporated into the Work. If data include more than one item in a tabular format, identify each item using appropriate references from the Contract Documents. Identify data applicable to the Work and delete references to information not applicable.
  - 1. Prepare supplementary text if manufacturers' standard printed data are not available and where the information is necessary for proper operation and maintenance of equipment or systems.
- E. Drawings: Prepare drawings supplementing manufacturers' printed data to illustrate the relationship of component parts of equipment and systems and to illustrate control sequence and flow diagrams. Coordinate these drawings with information contained in Record Drawings to ensure correct illustration of completed installation.
  - 1. Do not use original Project Record Documents as part of operation and maintenance manuals.
  - 2. Comply with requirements of newly prepared Record Drawings in Division 1 Section "Project Record Documents."
- F. Comply with Division 1 Sections for schedule for submitting operation and maintenance documentation.

END OF SECTION

**SECTION 017839 – PROJECT RECORD DOCUMENTS**

## PART 1 - GENERAL

## 1.1 RELATED DOCUMENTS

- A. Drawings and general provisions of the Contract, including General and Supplementary Conditions and other Division 1 Specification Sections, apply to this Section.

## 1.2 SUMMARY

- A. This Section includes administrative and procedural requirements for Project Record Documents, including the following:
  - 1. Record Drawings.
  - 2. Record Specifications.
  - 3. Record Product Data.
- B. Related Sections include the following:
  - 1. Division 1 Section for general closeout procedures.
  - 2. Division 1 Section "Operation and Maintenance Data" for operation and maintenance manual requirements.
  - 3. Divisions 2 through 33 Sections for specific requirements for Project Record Documents of the Work in those Sections.

## 1.3 SUBMITTALS

- A. Record Drawings: Comply with the following:
  - 1. Number of Copies: Submit one set(s) of marked-up Record Prints.
    - a. Final Submittal: Submit one set(s) of marked-up Record Prints showing modifications for trades involved in the project.
- B. Record Specifications: Submit one copy of Project's Specifications, including addenda and contract modifications.
- C. Record Product Data: Submit one copy of each Product Data submittal.
  - 1. Where Record Product Data is required as part of operation and maintenance manuals, submit marked-up Product Data as an insert in manual instead of submittal as Record Product Data.

## PART 2 - PRODUCTS

## 2.1 RECORD DRAWINGS

- A. Record Prints: Maintain one set of blue- or black-line white prints of the Contract Drawings and Shop Drawings.
1. Preparation: Mark Record Prints to show the actual installation where installation varies from that shown originally. Require individual or entity who obtained record data, whether individual or entity is Installer, subcontractor, or similar entity, to prepare the marked-up Record Prints.
    - a. Give particular attention to information on concealed elements that would be difficult to identify or measure and record later.
    - b. Accurately record information in an understandable drawing technique.
    - c. Record data as soon as possible after obtaining it. Record and check the markup before enclosing concealed installations.
  2. Content: Types of items requiring marking include, but are not limited to, the following:
    - a. Dimensional changes to Drawings.
    - b. Revisions to details shown on Drawings.
    - c. Depths of foundations below first floor.
    - d. Locations and depths of underground utilities.
    - e. Revisions to routing of piping and conduits.
    - f. Revisions to electrical circuitry.
    - g. Actual equipment locations.
    - h. Duct size and routing.
    - i. Locations of concealed internal utilities.
    - j. Changes made following Architect's written orders.
    - k. Details not on the original Contract Drawings.
    - l. Field records for variable and concealed conditions.
  3. Mark the Contract Drawings or Shop Drawings, whichever is most capable of showing actual physical conditions, completely and accurately. If Shop Drawings are marked, show cross-reference on the Contract Drawings.
  4. Mark record sets with erasable, red-colored pencil. Use other colors to distinguish between changes for different categories of the Work at same location.
  5. Mark important additional information that was either shown schematically or omitted from original Drawings.
  6. Note Construction Change Directive numbers, alternate numbers, Change Order numbers, and similar identification, where applicable.

## 2.2 RECORD SPECIFICATIONS

- A. Preparation: Mark Specifications to indicate the actual product installation where installation varies from that indicated in Specifications, addenda, and contract modifications.

1. Give particular attention to information on concealed products and installations that cannot be readily identified and recorded later.

## 2.3 MISCELLANEOUS RECORD SUBMITTALS

- A. Assemble miscellaneous records required by other Specification Sections for miscellaneous record keeping and submittal in connection with actual performance of the Work. Bind or file miscellaneous records and identify each, ready for continued use and reference.

## PART 3 - EXECUTION

### 3.1 RECORDING AND MAINTENANCE

- A. Recording: Maintain one copy of each submittal during the construction period for Project Record Document purposes. Post changes and modifications to Project Record Documents as they occur; do not wait until the end of Project.
- B. Maintenance of Record Documents and Samples: Store Record Documents and Samples in the field office apart from the Contract Documents used for construction. Do not use Project Record Documents for construction purposes. Maintain Record Documents in good order and in a clean, dry, legible condition, protected from deterioration and loss. Provide access to Project Record Documents for Architect's reference during normal working hours.

END OF SECTION

**SECTION 017900 - CLEANING**

## PART 1 - GENERAL

## 1.1 SUMMARY

- A. Work Included: Requirements for periodic, general, and final cleaning of the project.
- B. Provide temporary and periodic clean-up of extra materials, waste and general debris during construction of the work, together with the final clean-up and cleaning, polishing and other "housekeeping" required to bring various surfaces to an acceptable condition prior to final inspection, or before additional work is done during construction.
- C. This Section includes requirements for Cleaning for all phases of the Project. Some requirements of this Section may not be applicable to individual project Phases.

## 1.2 GENERAL REQUIREMENTS

- A. Maintain premises and public properties free from accumulations of waste, debris, and rubbish in accordance with applicable safety and insurance standards and local ordinances.
- B. The acceptable level of cleanliness of the Project shall be the decision of the Architect.
  - 1. Work necessary to achieve such acceptable state shall be performed when required.
- C. Burning: Burning of waste materials and/or rubbish on Site is not permitted.

## 1.3 CLEAN-UP DURING CONSTRUCTION

- A. During construction, provide cleaning-up as follows:
  - 1. Maintain areas free of waste materials, debris, and rubbish. Maintain site in a clean and orderly condition.
  - 2. Remove debris and rubbish from pipe chases, plenums, down spouts, attics, crawl spaces, and other closed or remote spaces, prior to enclosing the space.
  - 3. Broom and vacuum clean interior areas prior to start of surface finishing, and continue cleaning to eliminate dust.
  - 4. Remove waste materials, debris, and rubbish from site weekly, or more often if needed, and dispose off-site in compliance with local regulations.
  - 5. Storage areas: Ensure that materials to be used for construction are stored in designated structures or areas by the appropriate trades. Mai

maintain such areas or structures in a clean condition for the life of the Project.

6. Containers: Provide appropriate containers, such as dump containers, and locate on site for collection of waste materials and rubbish.
7. Supervision: Oversee all cleaning of areas by the trades using them. Ensure that resulting accumulations are deposited in appropriate containers.
8. Clean-up: Daily, weekly, or as necessary, clean-up floors and Site areas. Remove all loose materials, by sweeping if necessary.

#### 1.4 FINAL CLEANING

- A. Provide final clean-up and polishing just prior to final inspection and/or acceptance of the work of the Project.
- B. Preparation:
  1. Prior to final inspection, remove all loose material of any nature, except spare parts, loose furniture or furnishings, manuals, parts books, and similar items.
  2. Remove all temporary buildings, utility lines or pipes and other work of a temporary nature.
  3. Remove all temporary wrappings. Leave no trace of wrap or adhesive.
- C. Surface Cleaning:
  1. Special cleaning for specific units of Work as specified and as shown on Drawings.
  2. Provide final cleaning of the Work, at time indicated, consisting of cleaning each surface or unit of Work to normal "clean" condition expected for a first-class building cleaning and maintenance program.
  3. Comply with manufacturer's instructions for cleaning operations.
- D. The following are examples, but not by way of limitation, of cleaning levels required:
  1. Remove labels which are not required as permanent labels.
  2. Clean transparent materials, including mirrors and window/door glass, to a polished condition, removing substances which are noticeable as vision-obscuring materials. Replace broken glass and damaged transparent materials.
  3. Clean exposed exterior and interior hard-surfaced finishes to a dirt-free condition, free of dust, stains, films, and similar noticeable distracting substances.

- a. Except as otherwise indicated, avoid disturbance of natural weathering of exterior surfaces.
  - b. Restore reflective surfaces to original reflective condition.
  4. Wipe surfaces of mechanical and electrical equipment clean, including elevator equipment and similar equipment; remove excess lubrication and other substances.
  5. Remove debris and surface dust from limited-access spaces including roofs, plenums, shafts, trenches, equipment vaults, manholes, attics, and similar spaces.
  6. Clean concrete floors in unoccupied spaces broom clean.
  7. Vacuum clean carpeted surfaces and similar soft surfaces.
  8. Clean plumbing fixtures to a sanitary condition, free of stains including those resulting from water exposure.
  9. Clean light fixtures and lamps so as to function with full efficiency.
  10. Clean Project Site (staging areas, Contractor Parking areas), including landscape development areas, of litter and foreign substances.
  11. Sweep paved areas to a broom-clean condition; remove stains, petro-chemical spills, and other foreign deposits.
- E. Pest Control: Engage an experienced exterminator to make a final inspection of Project, and to rid Project of rodents, insects, and other pests.
- F. Removal of Protection: Except as otherwise indicated or requested by Hospital Representative, remove temporary protection devices and facilities which were installed during course of Work to protect previously completed Work during remainder of construction period.
- G. Compliances:
1. Comply with safety standards and governing regulations for cleaning operations.
  2. Do not burn waste materials at site, or bury debris or excess materials on the property, or discharge volatile or other harmful or dangerous materials into drainage systems.
  3. Remove waste materials from site and dispose of in a lawful manner.
- H. Moving Parts: Lubricate moving parts as recommended by the parts manufacturer, or as directed by the Architect. Wipe clean, all surplus lubricants.
- I. Protection: Protect finished floors from damage due to traffic or other causes.



END OF SECTION

**SECTION 024119 - SELECTIVE DEMOLITION**

## PART 1 - GENERAL

## 1.1 RELATED DOCUMENTS

- A. Drawings and general provisions of the Contract, including General and Supplementary Conditions and other Division 1 Specification Sections, apply to this Section.

## 1.2 SUMMARY

- A. This Section includes the following:
  - 1. Demolition and removal of selected portions of a building or structure.
  - 2. Repair procedures for selective demolition operations.

## 1.3 DEFINITIONS

- A. Remove: Carefully detach items from existing construction and legally dispose of them off-site, unless indicated to be removed and salvaged or removed and reinstalled.
- B. Remove and Reinstall: Detach items from existing construction, prepare them for reuse, and reinstall them where indicated.
- C. Existing to Remain: Existing items of construction that are not to be removed and that are not otherwise indicated to be removed, removed and salvaged, or removed and reinstalled.

## 1.4 MATERIALS OWNERSHIP

- A. Except for items or materials indicated to be reused, salvaged, reinstalled, or otherwise indicated to remain Owner's property, demolished materials shall become Contractor's property and shall be removed from Project site.

## 1.5 SUBMITTALS

- A. Proposed Dust-Control and Noise-Control Measures: Submit statement or drawing that indicates the measures proposed for use, proposed locations, and proposed time frame for their operation. Identify options if proposed measures are later determined to be inadequate.

## 1.6 PROJECT CONDITIONS

- A. Owner will occupy portions of building immediately adjacent to selective demolition area. Conduct selective demolition so Owner's operations will not be disrupted. Provide not less than 72 hours' notice to Owner of activities that will affect Owner's operations.
- B. Maintain access to existing walkways, corridors, and other adjacent occupied or used facilities.

1. Do not close or obstruct walkways, corridors, or other occupied or used facilities without written permission from authorities having jurisdiction.
- C. Owner assumes no responsibility for condition of areas to be selectively demolished.
1. Conditions existing at time of inspection for bidding purpose will be maintained by Owner as far as practical.
- D. Hazardous Materials: It is not expected that hazardous materials will be encountered in the Work.
1. If materials suspected of containing hazardous materials are encountered in the work, Contractor will be responsible for removal and disposal of all materials. A copy of an Asbestos Report will be provided to the Contractor prior to construction beginning. See Bid Proposal for unit price to remove hazardous materials.
- E. Storage or sale of removed items or materials on-site will not be permitted.
- F. Utility Service: Maintain existing utilities indicated to remain in service and protect them against damage during selective demolition operations.
1. Maintain fire-protection facilities in service during selective demolition operations.

## PART 2 - PRODUCTS (Not Applicable)

## PART 3 - EXECUTION

### 3.1 EXAMINATION

- A. Verify that utilities have been disconnected and capped.
- B. Survey existing conditions and correlate with requirements indicated to determine extent of selective demolition required.
- C. When unanticipated mechanical, electrical, or structural elements that conflict with intended function or design are encountered, investigate and measure the nature and extent of conflict. Promptly submit a written report to Architect.

### 3.2 UTILITY SERVICES

- A. Existing Utilities: Maintain services indicated to remain and protect them against damage during selective demolition operations.
- B. Do not interrupt existing utilities serving occupied or operating facilities unless authorized in writing by Owner and authorities having jurisdiction. Provide temporary services during interruptions to existing utilities, as acceptable to Owner and to authorities having jurisdiction.
  1. Provide at least 72 hours' notice to Owner if shutdown of service is required during changeover.

- C. Utility Requirements: Locate, identify, disconnect, and seal or cap off indicated utilities serving areas to be selectively demolished.

### 3.3 PREPARATION

- A. Temporary Enclosures: Provide temporary enclosures for protection of existing building and construction, in progress and completed, from exposure, foul weather, other construction operations, and similar activities. Provide temporary weathertight enclosure for building exterior.
  - 1. Where heating or cooling is needed and permanent enclosure is not complete, provide insulated temporary enclosures. Coordinate enclosure with ventilating and material drying or curing requirements to avoid dangerous conditions and effects.
- B. Temporary Partitions: Erect and maintain dustproof partitions and temporary enclosures to limit dust and dirt migration and to separate areas from fumes and noise.

### 3.4 SELECTIVE DEMOLITION

- A. General: Demolish and remove existing construction only to the extent required by new construction and as indicated. Use methods required to complete the Work within limitations of governing regulations and as follows:
  - 1. Neatly cut openings and holes plumb, square, and true to dimensions required. Use cutting methods least likely to damage construction to remain or adjoining construction. Use hand tools or small power tools designed for sawing or grinding, not hammering and chopping, to minimize disturbance of adjacent surfaces. Temporarily cover openings to remain.
  - 2. Cut or drill from the exposed or finished side into concealed surfaces to avoid marring existing finished surfaces.
  - 3. Dispose of demolished items and materials promptly.
- B. Existing Facilities: Comply with building manager's requirements for using and protecting building facilities during selective demolition operations.

### 3.5 DISPOSAL OF DEMOLISHED MATERIALS

- A. General: Promptly dispose of demolished materials. Do not allow demolished materials to accumulate on-site.
- B. Burning: Do not burn demolished materials.
- C. Disposal: Transport demolished materials off Owner's property and legally dispose of them.

END OF SECTION

**SECTION 035300- CONCRETE TOPPING**

## PART 1 - GENERAL

## 1.1 SUMMARY

- A. Work Included: Provide and install concrete toppings (cementitious underlayments), complete, as shown on Drawings and as specified, including:
  - 1. Miscellaneous tapers and warps for alignment of top-of-finish flooring at transitions between materials of different heights and thickness, including:
    - a. Section 093000 – Tile.
    - b. Section 096519 – Resilient Tile Flooring.
    - c. Section 096813 – Tile Carpeting
    - d. Concrete Floors without finish or painted finish.
  - 2. Remedial correction of interior floor slabs to provide specified floor flatness as specified in Section 033000 – Cast-in-Place Concrete; at no additional cost to Owner.
- B. Work Specified Elsewhere:
  - 1. Section 033000 – Cast-in-Place Concrete. Use concrete from this Section when the thickness is at least 2-inches.
  - 2. Section 093000– Tile; Polymer-modified mortars for tile assemblies sloped to drains.

## 1.2 SUBMITTALS

- A. Comply with requirements of Section 013300 – Submittal Requirements.
- B. Product Data: Manufacturer's literature describing materials and specifications for mixing, placing, curing, and protecting.

## 1.3 QUALITY ASSURANCE

- A. Applicator: Approved and trained by manufacturer.
- B. Design Criteria:
  - 1. Compressive Strength: Minimum 4,100-PSI at 28 Days per ASTM C109.

## 1.4 PRODUCT HANDLING

- A. Delivery: Deliver and store packaged materials in original containers with seals unbroken and labels intact until time of use.

- B. Storage: Ensure storage facilities are weathertight and dry.

## PART 2 - PRODUCTS

### 2.1 MANUFACTURERS

- A. General: Ardex Inc; Dependable Inc; or approved equal. Ardex products are specified as Basis-of-Design

### 2.2 MATERIALS

- A. Concrete Topping Types:

1. Self-Leveling Type for Interior Applications: Ardex K-15, or approved equal; 4,100-PSI compressive strength, 16-hour curing time. Installs from feather-edge depth to 1 1/2-inch depth without aggregate; installs up to 5-inch depth with addition of aggregate per manufacturer's written instructions.
2. Trowelable Fast-Setting Patch Type for Interior Applications: Ardex SD-P, or equal; 4,200-PSI compressive strength, 1-hour curing time. Installs from feather-edge depth to 1-inch depth without aggregate; installs up to 3-inch depth with addition of aggregate per manufacturer's written instructions.
3. Fast-Setting, Self-Leveling Type for Interior Applications: Ardex SD-T, or equal; 6,100-PSI compressive strength, 2-hour curing time. Installs from 1/4-inch to 2-inch depth without addition of aggregate, and up to 5-inches depth with addition of aggregate per manufacturer's written instructions.
4. Weather-Resistant, Self-Leveling Type for Interior Applications: Ardex A-300, 3,200-PSI compressive strength. Installs from 1/4-inch depth to 1/2-inch depth without aggregate; installs up to 3/4-inch depth with addition of aggregate per manufacturer's written instructions.
5. Polymer-Reinforced, Weather-Resistant Type for Interior Applications: Ardex Poly-Top, 5,500-PSI compressive strength. Installs from 1/4-inch depth to 1-inch depth without aggregate; installs up to 2-inch depth with addition of aggregate per manufacturer's written instructions.
6. Trowelable Fast-Setting Patch Type for Interior Applications: Ardex CD, 4,000-PSI compressive strength. Installs from 1/16-inch depth to 1/2-inch depth without aggregate.

- B. Primer: Ardex P-51, or equal, and as recommended in writing by the topping manufacturer for the substrata to receive topping.

- C. Aggregate:

1. Sand: 1/16-inch or less washed masonry sand, mortar sand, or plaster sand.

2. Gravel: 3/8-inch pea gravel.
- D. Water: Clean and potable, free from impurities detrimental to underlayment.

### PART 3 - EXECUTION

#### 3.1 EXAMINATION

- A. Verification of Conditions: Examine substrate and verify that surfaces are free from debris and are reasonably clean and dry and that conditions are otherwise suitable to receive topping. Do not start Work until conditions are satisfactory.

#### 3.2 PREPARATION

- A. Cracks and Voids: Fill with trowelable fast-setting patch type concrete topping.

#### 3.3 MIXES

- A. General: Mix concrete toppings per manufacturer's recommendations.
- B. Aggregates: Add sand or gravel aggregates to topping mix per manufacturer's recommendations for topping thickness.

#### 3.4 INSTALLATION

- A. General: Prime substrates, mix materials, and place toppings per manufacturer's recommendations.
- B. Thickness: Install to thickness as shown or as required, spreading and screeding to smooth surface; abut level to existing surface.
- C. Edge Forms: Provide as required.
- D. Ramps and Slopes to Drains: Including other accommodations for level changes; form with trowelable fast-setting patch type cementitious underlayment.
1. Sloped-to-Drain Setting bed materials for Patient Bathrooms, Showers and Tub Rooms provided in 093000 – Tile.
- E. Finish: As recommended by flooring manufacturer for reception of specified finish materials.
- F. Exterior Work: Provide weather-resistant toppings at concealed locations or at the written direction of the Owner.
- G. Transitions between Floor Finishes of differing thickness:
1. General: Provide concrete topping as required to align top-of-finish floor where flooring materials of different thickness meet.
  2. Performance Criteria:

- a. Provide concrete topping as required so that all offsets between adjacent floor materials are 1/8-inch or less.
  - b. Warp-applied concrete topping with a slope no greater than 1 inch in 48 inches, or a length of slope no less than 18 inches, whichever produces the more gentle transition.
3. Locations: Provide at locations where transitions between the following floor finishes occur that result in a vertical offset of greater than 1/8-inch:
- a. Section 093000 – Tile.
  - b. Section 096519 – Resilient Flooring.
  - c. Section 096813 – Tile Carpeting.
  - d. Concrete Floors without finish or painted finish.

### 3.5 CURING

- A. General: Allow concrete topping to harden as recommended by manufacturer.
- B. Traffic: Do not permit traffic on topping during hardening period; minimum 2 hours or longer.
- C. Loading: Do not load floors until reasonable strength has been achieved. Evenly distribute any loading on topping and prohibit concentrated loading.
- D. Conditions: Maintain adequate ventilation and temperature above 50 degrees F. until topping is dry.

### 3.6 CLEANING AND REPAIR

- A. General: Repair concrete topping damaged after installation as a result of other trades prior to installation of scheduled floor finish, if any, at no additional cost to Owner.

END OF SECTION



**SECTION 050500 – METAL FASTENERS****Part 1 - GENERAL****1.1 SUMMARY**

- A. Work Included: This Section establishes general standards and requirements for metal fasteners utilized for attachment of items to the primary structure of the building and is incorporated in others Sections of these specifications where referenced, including:
  - 1. Expansion Bolts.
  - 2. Bolts, screws and other fasteners.
- B. Work Specified Elsewhere:
  - 1. Division 5 – Miscellaneous Metal Fabrications.
  - 2. Division 23 – Mechanical.
  - 3. Division 26 – Electrical.

**1.2 SUBMITTALS**

- A. Comply with provisions of Section 01 33 00 – Submittal Procedures.
- B. Product Data: Manufacturers' information on materials, fabrication, and installation. Include current ICC or IAPMO Reports and other information to substantiate compliance with Contract Documents.
- C. Substitutions: Include with requests for substitution of fastening device type, minimum embedment, length, load capacity for pull out and shear, and installation torque of fasteners and statement that fastening devices meet or exceed requirements specified in Contract Documents.

**1.3 QUALITY ASSURANCE**

- A. Field Quality Control:
  - 1. The Owner's Testing Lab will perform and report on tests and inspections as follows:
  - 2. Expansion Bolts:
    - a. Test 50 percent of drilled-in anchorages to 2.0 times the allowable load specified with special inspection in tension.
    - b. If any anchor fails testing, test all anchors of the same category installed that day until twenty consecutive anchors pass, then resume the initial testing frequency. Cost of this testing shall be borne by Contractor.

**Part 2 - PRODUCTS****2.1 MATERIALS**

- A. Expansion Bolts: Hilti, Inc.'s Kwik Bolt TZ2, E.O.R. approved equivalent or as indicated. Provide stainless steel expansion bolts for exterior exposure.
- B. Sheet Metal Screws: John Wagner Associates' Grabber or equal: Unless otherwise noted on Drawings, type to suit stud, track, or channel gauge and as follows.
  - 1. Where Overlaid with Gypsum Board or Other Finish Material:
    - a. For Fastening to 20 Gauge and Lighter Material: No. 8 by 9/16-inch Wafer Head Streaker.
    - b. For Fastening to 18 Gauge and Heavier Material: No. 8 by 1/2-inch Wafer Head Self-Drilling.

2. Where Not Overlaid with Finish Material:
  - a. For Fastening to 20 Gauge and Lighter Material: No. 8 by 9/16-inch Hex Head Streaker.
  - b. For Fastening to 18 Gauge and Heavier Material: No. 8 by 1/2-inch Hex Head Self-Drilling.
- C. Nuts and Bolts: ASTM A307 with suitable nuts, in accordance with ASTM A563, and washers 1/4-inch diameter, unless otherwise noted.
- D. U-Bolts: Special sizes and shapes shown; material as specified for nuts and bolts.

### Part 3 - EXECUTION

#### 3.1 INSTALLATION

- A. Expansion Bolts: Install in predrilled holes for fastening items into concrete.
  1. Install expansion bolts according to the manufacturer's instructions as to tools, torque and tightening procedure.
  2. Expansion bolt locations and spacings: As shown.
  3. Edge Distance: Not less than 10 bolt diameters.
  4. Unless otherwise noted, install expansion bolts with manufacturer's recommended minimum embedments. Embedment length is exclusive of thickness of floor coverings, grout pads or other overlays.
  5. Do not recess expansion bolts more than one-fourth of the nominal bolt diameter. Abandon overdrilled holes or partially fill with nonshrink grout and redrill when grout has set.
  6. Abandon holes if the axis of a drilled hole deviates more than 5 degrees from normal to the concrete surface.
  7. If a concrete reinforcing bar is encountered during drilling, immediately terminate drilling and notify the Architect. Subject to review and approval the SEOR, the Architect may authorize using one of the following procedures:
    - a. If the location may be shifted, fill abandoned hole with nonshrink grout and install expansion bolt with a minimum of 1/2 inch of sound concrete between the expansion bolt and the abandoned hole, or...
    - b. If the location may not be shifted, use a diamond core drill to cut the rebar and drill the hole beyond the reinforcing such that the whole wedge portion of the expansion bolt can be expanded below the bar, or...
    - c. If the location may not be shifted, core an oversize hole at the direction of the Architect and grout an acceptable anchor in place.
- B. Fasten Work tightly to prevent rattle or vibration except where expansion-contraction tolerances are required.
- C. When expansion bolts are installed through metal deck into concrete slab above, embedment shall not extend closer than 3/4-inch to top of concrete. Locate at center of bottom flute. Minimum embedment shall be 1-1/2-inches above top flute of decking.
- D. Expansion Bolt Test Values:
  1. Test Procedure: Apply proof test loads by means of hydraulic ram, calibrating spring loading device, or torque wrench without removing nut if possible. If not possible, remove nut and install a threaded coupler to same tightness as original nut using a torque wrench.
  2. Test Equipment: Calibrated by approved testing laboratory per standard industry procedures.

3. Expansion Bolts shall withstand following minimum test loads for specified wedge type anchors:

<u>Anchor Thread Size</u> (diameter in inches)	<u>Tension Test Load</u> (lbs.)	<u>Test Torque</u> (ft-lbs.)
1/4	800	10
3/8	1100	25
1/2	2000	50
5/8	2300	80
3/4	3700	150
1	5800	250

4. Acceptance Criteria:
- Hydraulic Ram Method: Expansion bolt is acceptable if there is no observable movement nor loosening of washer at application of tension test load.
  - Torque Wrench Method: Expansion bolt is acceptable if the test torque is reached within one-half turn of the nut.
5. Test Timing: Within 24 hours after expansion bolt installation and in the presence of the Inspector of Record.

END OF SECTION

**SECTION 061000- ROUGH CARPENTRY**

PART 1 - GENERAL

1.1 SUMMARY

- A. Work Included: Rough carpentry, complete, as shown on Drawings and as specified, including:
  - 1. Miscellaneous fire-treated blocking, backing and plywood as shown.
- B. Work Specified Elsewhere:
  - 1. Section 064123 – Interior Architectural Woodwork.

1.2 REFERENCE STANDARDS

- A. American Plywood Association (APA):
  - 1. Guide to Plywood Grades.
- B. American Wood Preservers Association (AWPA):
  - 1. C20; Structural Lumber - Fire-Retardant Treatment by Pressure Process.
  - 2. C27; Plywood - Fire-Retardant Treatment by Pressure Process.
  - 3. M4; Standard for the Care of Preservative-Treated Wood Products.
- C. West Coast Lumber Inspection Bureau (WCLIB):
  - 1. Standard Grading Rules for West Coast lumber.
- D. Western Wood Products Association (WWPA):
  - 1. Western Lumber Grading Rules.

1.3 SUBMITTALS

- A. Comply with requirements of Section 013300 – Submittal Requirements.
- B. Shop Drawings: Show specially fabricated rough hardware.

1.4 QUALITY ASSURANCE

- B. Comply with latest edition of the following standards:
  - 1. Western Coast Lumber Inspection Bureau (WCLIB) "Standard Grading Rules No. 16."
  - 2. Western Wood Products Association (WWPA) "Grading Rules for Western Lumber."

3. American Plywood Association (APA) "Guide to Plywood Grades."
  4. United States Product Standard (PS) "Construction and Industrial Plywood" (PS 1-74).
  5. American Wood Preserver's Association (AWPA):
    - a. "Structural Lumber - Fire-Retardant Treatment by Pressure Process" (AWPA C27-74).
    - b. "Plywood - Fire-Retardant Treatment by Pressure Process" (AWPA C27-74).
- C. Grade Marks: Identify all wood materials by official grade mark.
1. Lumber: Mark each piece of lumber with grade mark WCLIB (or WWPA) or of agency certified by WCLIB (or WWPA), and accompany each mill shipment to site by certificate of inspection by WCLIB (or WWPA) and FR-S where fire treatment is required.
  2. Softwood Plywood: Show Type, Grade, Class and Identification Index; per APA Guide to Plywood Grades, and per requirements of NBS PS-1.
- C. Fire-Retardant Treatment:
1. Fire-Retardant Treatment: UL classification FR-S.
  2. Obtain each type of fire-retardant treated wood products from one source for both treatment and fire-retardant formulation.
- D. Pressure treatment shall not adversely affect application, permanence, or appearance of finish paint systems.

## 1.5 PRODUCT HANDLING

- A. Facilities: Provide proper facilities for handling and storage of materials to prevent damage to edges, ends, and surfaces.
- B. Storage: Keep materials dry. Stack materials off ground on level flat forms, fully protected from weather.

## 1.6 PROJECT CONDITIONS

- A. Environmental Requirements: Maintain uniform moisture content of lumber at not more than 19 percent before, during and after installation.
- B. Sequencing and Scheduling: Coordinate details with other Work supporting, adjoining or fastening to rough carpentry Work.

## PART 2 - PRODUCTS

### 2.1 MATERIALS

- A. Wood (all wood shall be fire treated):  
ROUGH CARPENTRY

1. Lumber: Douglas fir; No. 3 or construction grade per WCLIB.
  2. Plywood: NBS PS-1 - grade structural one, C-C exterior.
  3. Use only material that is free of urea-formaldehyde.
- B. Fasteners:
1. Nails: Common wire typical.
  2. Powder-Actuated Devices (PAD): As specified in Section 050500 – Metal Fasteners.
  3. Expansion Bolts: As specified in Section 050500 – Metal Fasteners.
  4. Miscellaneous Hardware: Provide common screws, bolts, fastenings, washers and nuts, and other items required to complete rough carpentry Work.
  5. Finish: Hot-dip galvanize fasteners for exterior work.

## 2.2 ROUGH HARDWARE

- A. All exterior hardware shall be hot-dipped galvanized per ASTM A-123 Standards.
1. Nails:
    - a. Common wire for typical framing, blocking, etc. Box nails will not be allowed.
    - b. Annular ring common wire nails for plywood floor.
  2. Bolts: Hexagonal heads, Grade A conforming to ASTM A307.
  3. Washers: Washers for bearing against wood shall be provided under all bolt heads and nuts.
    - a. Malleable iron or steel plate having an area equal to 16 times the area of bolt or lag screw.
    - b. Steel washers shall have a thickness not less than 1/10 the length of the washer's longest side.
    - c. Malleable iron washers shall have a thickness not less than 1/2 the bolt or lag screw diameter and having a bearing surface for the nut or head equal in diameter to not less than the long diameter of the nut or head.
  4. Anchor Bolts: Hexagonal heads, Grade A conforming to ASTM 307, 1-1/2-inch-diameter by 10 inch.
  5. Rough Framing Connectors: KC Metal Products or approved equal. For connector type, see Drawings.

- B. Powder Driven Fasteners, Expansion Bolts and Expansion Anchors: As specified under 050500 – Metal Fasteners.

### 2.3 FABRICATION

- A. Lumber:
  - 1. Moisture Content: Air- or kiln-dry to 19 percent maximum moisture content at time of surfacing.
  - 2. Finish: Surfaced four sides, S4S, unless otherwise specified.
  - 3. Size: Per rules of governing standard. Sizes shown are nominal unless otherwise specified.
- B. Fire-Retardant Treated Lumber and Plywood: Pressure treat rough carpentry materials per Reference Standards to obtain specified UL Classification.
  - 1. Type: Hoover Treated Wood Products, "Exterior Fire-X," or equal.

## PART 3 - EXECUTION

### 3.1 EXAMINATION

- A. Verification of Conditions: Examine areas to receive rough carpentry Work and verify following:
  - 1. Completion of installation of building components to receive rough carpentry Work.
  - 2. That spacing, direction, and details of supports are correct to accommodate installation of blocking, backing, stripping, furring, and nailers.
  - 3. That surfaces are satisfactory to receive Work. Do not commence installation until unsatisfactory conditions have been corrected.

### 3.2 INSTALLATION

- A. General: Provide wood blocking, backing, furring, grounds, nailers, stripping, and similar items as detailed and otherwise required to anchor fixtures and equipment to be installed by other trades. Perform cutting, boring, and similar Work required. Install members true to line. Fit accurately. Secure rigidly. Provide special framing, even if not specifically shown, as required to properly complete Work.
- B. Sills or Plates on Concrete: Set in grout if surface of concrete deviates from true plane by more than 1/16-inch in 4 feet. Anchor with bolts as shown. Use two bolts minimum per piece with one bolt located between 4 inches and 8 inches from each end of each piece of sill.
- C. Nail Joints: Per minimum requirements of applicable code unless otherwise shown.
- D. Plywood: Sheet layout, nailing and edge-blocking as shown. Gap joints 1/16-

inch. Butt joints accurately at centerlines of supporting members.

E. Fasteners:

1. General: Furnish and accurately locate items to be embedded in concrete. Secure such items in place before concrete is poured.
2. Nails: If wood tends to split, pre-drill holes three-fourths of nail diameter.
3. Lag Screws: Screw into place; do not hammer. Use soap or other lubricant to ease insertion. Pre-drill holes diameter of shank for unthreaded portion, two-thirds of shank diameter for threaded portion.
4. Bolts and Nuts: When installed, bear no more than 1/2-inch of threads on wood and allow no more than 1/2-inch of bolt to project beyond nut. Drill bolt holes 1/32-inch oversize. Tighten nuts snug when placed, and re-tighten at end of job or just before closing in.
5. Sheet Metal Fasteners: Nail or bolt per manufacturer's instructions. Nail or bolt holes. Use nails provided by manufacturer.

3.3 PLYWOOD BACKING FOR TELEPHONE AND ELECTRICAL EQUIPMENT

- A. Panels: Not less than 3/4-inch thick. Use largest sizes practicable.
- B. Joints: Tightly butt vee-joints.
- C. Finish: Slightly ease exposed edges, sandpaper smooth as required.
- D. Fastening: Secure to metal studs and backing plates with flat-head countersunk sheet metal screws at 12-inch centers at panel edges and at 16-inch centers in panel field.

END OF SECTION



**SECTION 064123- INTERIOR ARCHITECTURAL WOODWORK**

## PART 1 - GENERAL

## 1.1 RELATED DOCUMENTS

- A. Drawings and general provisions of the Contract, including General and Supplementary Conditions and Division 1 Specification Sections, apply to this Section.

## 1.2 SUMMARY

- A. Work Included: Provide and install Casework, complete, as shown on Drawings and as specified. All casework to be:

**AWI Premium Grade Fabrications.**

- B. This Section includes the following:

- 1. Plastic-laminate cabinets.
- 2. Plastic-laminate countertops.
- 3. Solid-surfacing-material countertops and integral sinks.

- C. Related Sections include the following:

- 1. Division 6 Section "Rough Carpentry" for wood furring, blocking, shims, and hanging strips required for installing woodwork and concealed within other construction before woodwork installation.
- 2. Division 8 Section "Flush Wood Doors."

## 1.3 DEFINITIONS

- A. Interior architectural woodwork includes wood furring, blocking, shims, and hanging strips for installing woodwork items, unless concealed within other construction before woodwork installation.

## 1.4 SUBMITTALS

- A. Shop Drawings: Show location of each item, dimensioned plans and elevations, large-scale details, attachment devices, and other components.

- B. Samples for Initial Selection: Manufacturer's color charts consisting of units or sections of units showing the full range of colors, textures, and patterns available for each type of material indicated.

- 1. Plastic laminates.
- 2. Shop-applied transparent finishes.

- C. Samples for Verification:

1. Plastic laminates, 8 by 10 inches, for each type, color, pattern, and surface finish.
2. Solid-surfacing materials, 6 inches square.
3. One sample door with required hardware.

#### 1.5 QUALITY ASSURANCE

- A. Installer Qualifications: An experienced installer who has completed architectural woodwork similar in material, design, and extent to that indicated for this Project and whose work has resulted in construction with a record of successful in-service performance.
- B. Fabricator Qualifications:
  1. Shop that employs skilled workers who custom-fabricate products similar to those required for this Project and whose products have a record of successful in-service performance.
  2. Shop is a certified participant in AWI's Quality Certification
- C. Quality Standard: Unless otherwise indicated, comply with AWI's "Architectural Woodwork Quality Standards" for grades of interior architectural woodwork, construction, finishes, and other requirements.
  1. Provide AWI certification labels or compliance certificate indicating that woodwork complies with requirements of grades specified.
- D. Single-sourcing materials: It is the intent of the Contract Documents to single-source plastic laminate and solid surface materials specified in this section when scheduled on the drawings to assure matching of specified finishes.

#### 1.6 DELIVERY, STORAGE, AND HANDLING

- A. Do not deliver woodwork until painting and similar operations that could damage woodwork have been completed in installation areas. If woodwork must be stored in other than installation areas, store only in areas where environmental conditions comply with requirements specified in "Project Conditions" Article.

#### 1.7 PROJECT CONDITIONS

- A. Environmental Limitations: Do not deliver or install woodwork until building is enclosed, wet work is complete, and HVAC system is operating and maintaining temperature and relative humidity at occupancy levels during the remainder of the construction period.
- B. Field Measurements: Where woodwork is indicated to fit to other construction, verify dimensions of other construction by field measurements before fabrication and indicate measurements on Shop Drawings. Coordinate fabrication schedule with construction progress to avoid delaying the Work.
  1. Established Dimensions: Where field measurements cannot be made without delaying the Work, establish dimensions and proceed with fabricating woodwork without field measurements. Provide allowance for trimming at site, and coordinate construction to ensure that actual dimensions correspond to established dimensions.

## 1.8 COORDINATION

- A. Coordinate sizes and locations of framing, blocking, furring, reinforcements, and other related units of Work specified in other Sections to ensure that interior architectural woodwork can be supported and installed as indicated.

## PART 2 - PRODUCTS

## 2.1 MATERIALS

- A. General: Provide materials that comply with requirements of the AWI quality standard for each type of woodwork and quality grade specified, unless otherwise indicated.
- B. Wood Species and Cut for Transparent Finish:
  - 1. Species: Maple (Acer Saccharum)
  - 2. Application:
    - a. Cut: Plan Sliced
    - b. Figure: All light colored wood
    - c. Face Panel Grade: HPVA Grade A
    - d. Color: Stain to match patient room cabinets on adjacent floors
- C. Wood Products: Comply with the following:
  - 1. Hardboard: AHA A135.4.
  - 2. Softwood Plywood: DOC PS 1, Medium Density Overlay.
  - 3. Hardwood Plywood and Face Veneers: HPVA HP-1.
- D. Thermoset Decorative Overlay: Particleboard complying with ANSI A208.1, Grade M-2, or medium-density fiberboard complying with ANSI A208.2, Grade MD, with surface of thermally fused, melamine-impregnated decorative paper complying with LMA SAT-
- E. High-Pressure Decorative Laminate: NEMA LD 3, grades as indicated, or if not indicated, as required by woodwork quality standard.
  - 1. Manufacturer: Subject to compliance with requirements, provide high-pressure decorative laminates by one of the following:
    - a. Laminart
- F. Solid-Surfacing Material: Homogeneous solid sheets of filled plastic resin complying with ISSFA-2.
  - 1. Manufacturers: Subject to compliance with requirements, provide products by one of the following:
    - a. Solid Surface: Corian
  - 2. Type: Standard slab type, unless Special Purpose type is indicated.
  - 3. Colors and Patterns: as per finish schedule.

## G. Solid-Surfacing Material: Quartz

1. Manufacturers: Subject to compliance with requirements, provide products by one of the following:
  - a. Solid Surface (Quartz): Cambria Quartz (2cm)
2. Type: Standard slab type, unless Special Purpose type is indicated.
3. Colors and Patterns: As per finish schedule.

## H. Adhesive for Bonding Plastic Laminate: Contact cement.

## I. Edge-banding:

1. Edge-banding for cabinet body parts shall be purified **3 mm PVC** applied with hot melt glue by automatic edge-banding equipment.
2. Edge-banding for door and drawer fronts shall be purified 3 mm PVC applied with hot melt glue by automatic edge-banding equipment. Edges and corners shall be rounded with a 3 mm radius and scraped free from machining or chatter marks.
3. Color shall match vertical laminate at cabinets or as selected by Architect from manufacturer's full color range for solids and patterns.

## J. Cores:

1. All sides, tops, countertops, bottoms, doors, drawer fronts, and partitions shall have minimum  $\frac{3}{4}$ " thick multi-core premium grade panel product cores manufactured for uses as a core material for laminated casework. Provide 1-inch thickness for bottom panel of wall hung units (same as shelves).
2. Shelf Cores: Shelves shall have the same core material as specified for the cabinet body except provide  $\frac{3}{4}$ -inch thickness.
3. Multi-Core Panel Products:

Simpson Plyron, Simpson  
States Industries "Armorcore"  
True North "**Multi - Core**"

## 2.2 CABINET HARDWARE AND ACCESSORIES

- A. General: Provide cabinet hardware and accessory materials associated with architectural cabinets.
- B. Hardware Standard: Comply with BHMA A156.9 for items indicated by referencing BHMA numbers or items referenced to this standard.
- C. Frameless Concealed Hinges (European Type): BHMA A156.9, B01602, 170 degrees of opening, self-closing.
- D. Door and Drawer Pulls: Back mounted, 4 inches long, wire pull, Finish- Satin Nickel, 5/16" in diameter.
- E. Catches: Magnetic catches, BHMA A156.9, B03141.

- F. Shelf Rests: BHMA A156.9, B04013.
- G. Drawer Slides: Side-mounted, full-extension, zinc-plated steel drawer slides with steel ball bearings, BHMA A156.9, B05091, and rated for the following loads:
  - 1. Box Drawer Slides: 100 lbf.
  - 2. Pencil Drawer Slides: 45 lbf.
- H. Door Locks: BHMA A156.11, E07121. **(Typical at base cabinets at sink locations)**
- I. Drawer Locks: BHMA A156.11, E07041.
- J. Keyboard Trays: VersaTables, 24 inches wide, 14 inches deep, Model KD-2414
- K. Grommets for Cable Passage through Countertops: 2-1/2-inch beige, molded-plastic grommets and matching plastic caps with slot for wire passage.
- L. Exposed Hardware Finishes: For exposed hardware, provide finish that complies with BHMA A156.18 for BHMA finish number indicated.
  - 1. Satin Chromium Plated: BHMA 652 for steel base.
- M. For concealed hardware, provide manufacturer's standard finish that complies with product class requirements in BHMA A156.9.
- N. Keyless Security Locks :
  - a. Keyless access
  - b. Four digit code
  - c. Power: Operates on two 1.5V AAA batteries
  - d. Operation: 15,000 openings
  - e. Low battery signal with battery failure override
  - f. Dimensions: 5-3/8 inches long by 1-1/4 inches wide by 1-3/16 inches deep to top of handle
  - g. Color: Selected by Architect
  - h. Public/private function
  - i. Base Product: Kit-Lock KL1000 by Codelocks Ltd.

### 2.3 INSTALLATION MATERIALS

- A. Furring, Blocking, Shims, and Hanging Strips: Softwood or hardwood lumber, kiln-dried to less than 15 percent moisture content.
- B. Anchors: Select material, type, size, and finish required for each substrate for secure anchorage. Provide nonferrous-metal or hot-dip galvanized anchors and inserts on inside face of exterior walls and elsewhere as required for corrosion resistance. Provide toothed-steel or lead expansion sleeves for drilled-in-place anchors.

### 2.4 FABRICATION, GENERAL

- A. Interior Woodwork Grade: Provide **Premium Grade** interior woodwork complying with the referenced quality standard.

- B. Wood Moisture Content: Comply with requirements of referenced quality standard for wood moisture content in relation to ambient relative humidity during fabrication and in installation areas.
- C. Complete fabrication, including assembly, finishing, and hardware application, to maximum extent possible, before shipment to Project site. Disassemble components only as necessary for shipment and installation. Where necessary for fitting at site, provide ample allowance for scribing, trimming, and fitting.

## 2.5 INTERIOR STANDING AND RUNNING TRIM FOR TRANSPARENT FINISH

- A. Quality Standard: Comply with AWI Section 300.
- B. Grade: **Premium.**

## 2.6 PLASTIC-LAMINATE CABINETS

- A. Quality Standard: Comply with AWI Section 400 requirements for laminate cabinets.
- B. Grade: **Premium.**
- C. AWI Type of Cabinet Construction: Flush overlay.
- D. Laminate Cladding for Exposed Surfaces: High-pressure decorative laminate complying with the following requirements:
  - 1. Horizontal Surfaces Other Than Tops: HGP.
  - 2. Vertical Surfaces: VGS.
  - 3. Edges: PVC T-mold matching laminate in color, pattern, and finish.
- E. Materials for Semi-exposed Surfaces: Provide surface materials indicated below:
  - 1. Surfaces Other Than Drawer Bodies: High-pressure decorative laminate, Grade VGS.
  - 2. Drawer Sides and Backs: Melamine.
  - 3. Drawer Bottoms: Melamine
- F. Materials for Exposed Surfaces: Plastic Laminate
- G. Retain one each from three groups below or revise to suit Project.
- H. Colors, Patterns, and Finishes: Provide materials and products that result in colors and textures of exposed laminate surfaces complying with the following requirements:
  - 1. Provide Architect's selections from laminate manufacturer's full range of colors and finishes in the following categories:
    - a. Solid colors.
    - b. Patterns.

## 2.7 PLASTIC-LAMINATE COUNTERTOPS

- A. Quality Standard: Comply with AWI Section 400 requirements for high-pressure decorative laminate countertops.
- B. Grade: **Premium**.
- C. High-Pressure Decorative Laminate Grade: HGS.
- D. Colors, Patterns, and Finishes: Provide materials and products that result in colors and textures of exposed laminate surfaces complying with the following requirements:
  - 1. Provide Architect's selections from manufacturer's full range of colors and finishes in the following categories:
    - a. Solid colors.
    - b. Patterns.
- E. Edge Treatment: Countertop front edge shall be bullnose type with same laminate cladding on horizontal surfaces. Side edge, that is visible, shall be finished with same laminate cladding on horizontal surfaces.
- F. Core Material: Shall be ¾" thick solid plywood or high density particle board built up to 1-1/2".
- G. Side Splash: Provide ¾" side splash at all locations where counter abuts perpendicular wall. Side splash shall be attached to wall but not to countertop to allow for expansion or contraction of countertop after installation.

## 2.8 SOLID-SURFACING-MATERIAL COUNTERTOPS

- A. Grade: Premium.
- B. Solid-Surfacing-Material Thickness: 1/2 inch, Finish 1-1/2"
- C. Colors, Patterns, and Finishes: Provide materials and products that result in colors of solid-surfacing material complying with the following requirements:
  - 1. Match project finish schedule. Provide Architect with sample for verification.
- D. Fabricate tops in one piece, unless otherwise indicated. Comply with solid-surfacing-material manufacturer's written recommendations for adhesives, sealers, fabrication, and finishing.
  - 1. Fabricate tops with shop-applied edges of materials and configuration indicated.
  - 2. Provide **Integral** back splash.
  - 3. Provide **Integral** side splash where countertop abuts perpendicular wall or cabinet.
  - 4. Provide full bullnose edge at exposed edge of counter.
  - 5. Provide ¾" radius edge at the top of back and side splash.
- E. Integral Sinks: Provide factory fabricated integral sinks where shown and scheduled on Drawings.

1. Provide **Corian, Model 804P, Color: Glacier White**

2.9 Wood Veneer Casework:

1. Applicable Standard: AWI Section 400A - Wood Cabinets.
2. Grade: Premium.
3. Construction Style: Flush overlay.
4. Scribing: Flush with door faces and per Premium Grade regardless of specified casework grade.
5. Materials:
  - a. Exposed Surfaces: Hardwood plywood.
  - b. Semi-Exposed Surfaces: Hardwood Plywood.
  - c. Edges: Wood veneer tape banding to match exposed surfaces, not less than 1/16-inch-thick.

PART 3 - EXECUTION

3.1 PREPARATION

- A. Condition woodwork to average prevailing humidity conditions in installation areas before installation.
- B. Before installing architectural woodwork, examine shop-fabricated work for completion and complete work as required, including removal of packing and backpriming.

3.2 INSTALLATION

- A. Quality Standard: Install woodwork to comply with AWI Section 1700 for the same grade specified in Part 2 of this Section for type of woodwork involved.
- B. Install woodwork level, plumb, true, and straight. Shim as required with concealed shims. Install level and plumb (including tops) to a tolerance of 1/8 inch in 96 inches.
- C. Scribe and cut woodwork to fit adjoining work, and refinish cut surfaces and repair damaged finish at cuts.
- D. Anchor woodwork to anchors or blocking built in or directly attached to substrates. Secure with countersunk, concealed fasteners and blind nailing as required for complete installation.
- E. Standing and Running Trim: Install with minimum number of joints possible, using full-length pieces (from maximum length of lumber available) to greatest extent possible. Do not use pieces less than 36 inches long, except where shorter single-length pieces are necessary.



- F. Cabinets: Install without distortion so doors and drawers fit openings properly and are accurately aligned. Adjust hardware to center doors and drawers in openings and to provide unencumbered operation. Complete installation of hardware and accessory items as indicated.
1. Install cabinets with no more than 1/8 inch in 96-inch sag, bow, or other variation from a straight line.
  2. Fasten wall cabinets through back, near top and bottom, at ends and not more than 16 inches o.c. with No. 10 wafer-head screws sized for 1-inch penetration into wood framing, blocking, or hanging strips.
- G. Countertops: Anchor securely by screwing through corner blocks of base cabinets or other supports into underside of countertop.
1. Install countertops with no more than 1/8 inch in 96-inch sag, bow, or other variation from a straight line.
  2. Secure backsplashes to tops and to walls.
  3. Calk space between backsplash and wall with sealant specified in Division 7 Section "Joint Sealants."
  4. Cut circular openings in countertop for electrical cord access below countertop. Provide a grommet around opening for finish appearance. Color of grommet to match countertop. The number of openings required will be determined by the Owner but will not exceed 250.
  5. Cut openings in countertops for the installation of grilles as indicated on the drawings and as approved by Architect.
  6. Provide full bullnose edge, Typical

### 3.3 ADJUSTING AND CLEANING

- A. Repair damaged and defective woodwork, where possible, to eliminate functional and visual defects; where not possible to repair, replace woodwork. Adjust joinery for uniform appearance.
- B. Clean, lubricate, and adjust hardware.
- C. Clean woodwork on exposed and semi-exposed surfaces. Touch up shop-applied finishes to restore damaged or soiled areas.

END OF SECTION

**SECTION 078100 - APPLIED FIREPROOFING**

## PART 1 - GENERAL

## 1.1 RELATED DOCUMENTS

- A. Drawings and general provisions of the Contract, including General and Supplementary Conditions and Division 01 Specification Sections, apply to this Section.

## 1.2 SUMMARY

- A. Section includes sprayed fire-resistive materials.
- B. Related Requirements:
  - 1. Section 078123 "Intumescent Fireproofing" for mastic and intumescent fire-resistive coatings.
  - 2. Section 099646 "Intumescent Painting" for intumescent paints that are fire retarding but not fire resistive.

## 1.3 DEFINITIONS

- A. SFRM: Sprayed fire-resistive materials.

## 1.4 PREINSTALLATION MEETINGS

- A. Preinstallation Conference: Conduct conference at Project site.
  - 1. Review products, design ratings, restrained and unrestrained conditions, densities, thicknesses, bond strengths, and other performance requirements.

## 1.5 ACTION SUBMITTALS

- A. Product Data: For each type of product.
- B. Shop Drawings: Framing plans or schedules, or both, indicating the following:
  - 1. Extent of fireproofing for each construction and fire-resistance rating.
  - 2. Applicable fire-resistance design designations of a qualified testing and inspecting agency acceptable to authorities having jurisdiction.
  - 3. Minimum fireproofing thicknesses needed to achieve required fire-resistance rating of each structural component and assembly.
  - 4. Treatment of fireproofing after application.
- C. Samples: For each exposed product and for each color and texture specified, in manufacturer's standard dimensions in size.

## 1.6 INFORMATIONAL SUBMITTALS

- A. Qualification Data: For Installer.
- B. Product Certificates: For each type of fireproofing.
- C. Evaluation Reports: For fireproofing, from ICC-ES.
- D. Preconstruction Test Reports: For fireproofing.
- E. Field quality-control reports.

## 1.7 QUALITY ASSURANCE

- A. Installer Qualifications: A firm or individual certified, licensed, or otherwise qualified by fireproofing manufacturer as experienced and with sufficient trained staff to install manufacturer's products according to specified requirements.

## 1.8 PRECONSTRUCTION TESTING

- A. Preconstruction Adhesion and Compatibility Testing: Test for compliance with requirements for specified performance and test methods.
  - 1. Bond Strength: Test for cohesive and adhesive strength according to ASTM E 736. Provide bond strength indicated in referenced fire-resistance design, but not less than minimum specified in Part 2.
  - 2. Density: Test for density according to ASTM E 605. Provide density indicated in referenced fire-resistance design, but not less than minimum specified in Part 2.
  - 3. Verify that manufacturer, through its own laboratory testing or field experience, attests that primers or coatings are compatible with fireproofing.
  - 4. Schedule sufficient time for testing and analyzing results to prevent delaying the Work.
  - 5. For materials failing tests, obtain applied-fireproofing manufacturer's written instructions for corrective measures including the use of specially formulated bonding agents or primers.

## 1.9 FIELD CONDITIONS

- A. Environmental Limitations: Do not apply fireproofing when ambient or substrate temperature is 44 deg F or lower unless temporary protection and heat are provided to maintain temperature at or above this level for 24 hours before, during, and for 24 hours after product application.
- B. Ventilation: Ventilate building spaces during and after application of fireproofing, providing complete air exchanges according to manufacturer's written instructions. Use natural means or, if they are inadequate, forced-air circulation until fireproofing dries thoroughly.

## PART 2 - PRODUCTS

## 2.1 PERFORMANCE REQUIREMENTS

- A. Assemblies: Provide fireproofing, including auxiliary materials, according to requirements of each fire-resistance design and manufacturer's written instructions.
- B. Source Limitations: Obtain fireproofing from single source.
- C. Fire-Resistance Design: Indicated on Drawings, tested according to ASTM E 119 or UL 263; testing by a qualified testing agency. Identify products with appropriate markings of applicable testing agency.
  - 1. Steel members are to be considered unrestrained unless specifically noted otherwise.
- D. Asbestos: Provide products containing no detectable asbestos.

## 2.2 SPRAYED FIRE-RESISTIVE MATERIALS

- A. Sprayed Fire-Resistive Material UL P701: Manufacturer's standard, factory-mixed, lightweight, dry formulation, complying with indicated fire-resistance design, and mixed with water at Project site to form a slurry or mortar before conveyance and application.
  - 1. Manufacturers: Subject to compliance with requirements, provide products by one of the following:
    - a. Carbolite Company; a subsidiary of RPM International.
    - b. Grace Construction Products; W.R. Grace & Co. -- Conn.
    - c. Isolatek International.
    - d. Pyrok, Inc.
    - e. Schundler Company (The).
    - f. Southwest Fireproofing Products Co.
  - 2. Application: Designated for exterior use by a qualified testing agency acceptable to authorities having jurisdiction.
  - 3. Bond Strength: Minimum 430-lbf/sq. ft. cohesive and adhesive strength based on field testing according to ASTM E 736.
  - 4. Density: Not less than density specified in the approved fire-resistance design, according to ASTM E 605.
  - 5. Thickness: As required for fire-resistance design indicated, measured according to requirements of fire-resistance design or ASTM E 605, whichever is thicker, but not less than 0.375 inch.
  - 6. Combustion Characteristics: ASTM E 136.
  - 7. Surface-Burning Characteristics: Comply with ASTM E 84; testing by a qualified testing agency. Identify products with appropriate markings of applicable testing agency.
    - a. Flame-Spread Index: 10 or less.
    - b. Smoke-Developed Index: 10 or less.

8. Compressive Strength: Minimum 100 lbf/sq. in. according to ASTM E 761.
9. Corrosion Resistance: No evidence of corrosion according to ASTM E 937.
10. Deflection: No cracking, spalling, or delamination according to ASTM E 759.
11. Effect of Impact on Bonding: No cracking, spalling, or delamination according to ASTM E 760.
12. Air Erosion: Maximum weight loss of 0.025 g/sq. ft. in 24 hours according to ASTM E 859.
13. Fungal Resistance: Treat products with manufacturer's standard antimicrobial formulation to result in no growth on specimens per ASTM G 21
14. Sound Absorption: NRC of 0.50 to 0.75 according to ASTM C 423 for Type A mounting according to ASTM E 795.
15. Finish: As selected by Architect from manufacturer's standard finishes
  - a. Color: As selected by Architect from manufacturer's full range.

### 2.3 AUXILIARY MATERIALS

- A. General: Provide auxiliary materials that are compatible with fireproofing and substrates and are approved by UL or another testing and inspecting agency acceptable to authorities having jurisdiction for use in fire-resistance designs indicated.
- B. Substrate Primers: Primers approved by fireproofing manufacturer and complying with one or both of the following requirements:
  1. Primer and substrate are identical to those tested in required fire-resistance design by UL or another testing and inspecting agency acceptable to authorities having jurisdiction.
  2. Primer's bond strength in required fire-resistance design complies with specified bond strength for fireproofing and with requirements in UL's "Fire Resistance Directory" or in the listings of another qualified testing agency acceptable to authorities having jurisdiction, based on a series of bond tests according to ASTM E 736.
- C. Bonding Agent: Product approved by fireproofing manufacturer and complying with requirements in UL's "Fire Resistance Directory" or in the listings of another qualified testing agency acceptable to authorities having jurisdiction.
- D. Metal Lath: Expanded metal lath fabricated from material of weight, configuration, and finish required, according to fire-resistance designs indicated and fireproofing manufacturer's written instructions. Include clips, lathing accessories, corner beads, and other anchorage devices required to attach lath to substrates and to receive fireproofing.
- E. Reinforcing Fabric: Glass- or carbon-fiber fabric of type, weight, and form required to comply with fire-resistance designs indicated; approved and provided by fireproofing manufacturer.
- F. Reinforcing Mesh: Metallic mesh reinforcement of type, weight, and form required to comply with fire-resistance design indicated; approved and provided by fireproofing manufacturer. Include pins and attachment.

- G. Sealer: Transparent-drying, water-dispersible, tinted protective coating recommended in writing by fireproofing manufacturer for each fire-resistance design.
- H. Topcoat: Suitable for application over applied fireproofing; of type recommended in writing by fireproofing manufacturer for each fire-resistance design.
  - 1. Cement-Based Topcoat: Factory-mixed, cementitious hard-coat formulation for trowel or spray application over SFRM.
  - 2. Water-Based Permeable Topcoat: Factory-mixed formulation for brush, roller, or spray application over applied SFRM. Provide application at a rate of 30 sq. ft./gal.

### PART 3 - EXECUTION

#### 3.1 EXAMINATION

- A. Examine substrates, areas, and conditions, with Installer present, for compliance with requirements for substrates and other conditions affecting performance of the Work and according to each fire-resistance design.
  - 1. Verify that substrates are free of dirt, oil, grease, release agents, rolling compounds, mill scale, loose scale, incompatible primers, paints, and encapsulants, or other foreign substances capable of impairing bond of fireproofing with substrates under conditions of normal use or fire exposure.
  - 2. Verify that objects penetrating fireproofing, including clips, hangers, support sleeves, and similar items, are securely attached to substrates.
  - 3. Verify that substrates receiving fireproofing are not obstructed by ducts, piping, equipment, or other suspended construction that will interfere with fireproofing application.
- B. Verify that concrete work on steel deck is complete before beginning fireproofing work.
- C. Verify that roof construction, installation of rooftop HVAC equipment, and other related work are complete before beginning fireproofing work.
- D. Conduct tests according to fireproofing manufacturer's written instructions to verify that substrates are free of substances capable of interfering with bond.
- E. Prepare written report, endorsed by Installer, listing conditions detrimental to performance of the Work.
- F. Proceed with installation only after unsatisfactory conditions have been corrected.

#### 3.2 PREPARATION

- A. Cover other work subject to damage from fallout or overspray of fireproofing materials during application.
- B. Clean substrates of substances that could impair bond of fireproofing.

- C. Prime substrates where included in fire-resistance design and where recommended in writing by fireproofing manufacturer unless compatible shop primer has been applied and is in satisfactory condition to receive fireproofing.
- D. For applications visible on completion of Project, repair substrates to remove surface imperfections that could affect uniformity of texture and thickness in finished surface of fireproofing. Remove minor projections and fill voids that would telegraph through fire-resistive products after application.

### 3.3 APPLICATION

- A. Construct fireproofing assemblies that are identical to fire-resistance design indicated and products as specified, tested, and substantiated by test reports; for thickness, primers, sealers, topcoats, finishing, and other materials and procedures affecting fireproofing work.
- B. Comply with fireproofing manufacturer's written instructions for mixing materials, application procedures, and types of equipment used to mix, convey, and apply fireproofing; as applicable to particular conditions of installation and as required to achieve fire-resistance ratings indicated.
- C. Coordinate application of fireproofing with other construction to minimize need to cut or remove fireproofing.
  - 1. Do not begin applying fireproofing until clips, hangers, supports, sleeves, and other items penetrating fireproofing are in place.
  - 2. Defer installing ducts, piping, and other items that would interfere with applying fireproofing until application of fireproofing is completed.
- D. Metal Decks:
  - 1. Do not apply fireproofing to underside of metal deck substrates until concrete topping, if any, is completed.
  - 2. Do not apply fireproofing to underside of metal roof deck until roofing is completed; prohibit roof traffic during application and drying of fireproofing.
- E. Install auxiliary materials as required, as detailed, and according to fire-resistance design and fireproofing manufacturer's written instructions for conditions of exposure and intended use. For auxiliary materials, use attachment and anchorage devices of type recommended in writing by fireproofing manufacturer.
- F. Spray apply fireproofing to maximum extent possible. After the spraying operation in each area, complete the coverage by trowel application or other placement method recommended in writing by fireproofing manufacturer.
- G. Extend fireproofing in full thickness over entire area of each substrate to be protected.
- H. Install body of fireproofing in a single course unless otherwise recommended in writing by fireproofing manufacturer.

- I. For applications over encapsulant materials, including lockdown (post-removal) encapsulants, apply fireproofing that differs in color from that of encapsulant over which it is applied.
- J. Where sealers are used, apply products that are tinted to differentiate them from fireproofing over which they are applied.
- K. Provide a uniform finish complying with description indicated for each type of fireproofing material and matching finish approved for required mockups.
- L. Cure fireproofing according to fireproofing manufacturer's written instructions.
- M. Do not install enclosing or concealing construction until after fireproofing has been applied, inspected, and tested and corrections have been made to deficient applications.
- N. Finishes: Where indicated, apply fireproofing to produce the following finishes:
  - 1. Manufacturer's Standard Finishes: Finish according to manufacturer's written instructions for each finish selected.
  - 2. Spray-Textured Finish: Finish left as spray applied with no further treatment.
  - 3. Rolled, Spray-Textured Finish: Even finish produced by rolling spray-applied finish with a damp paint roller to remove drippings and excessive roughness.
  - 4. Skip-Troweled Finish: Even leveled surface produced by troweling spray-applied finish to smooth out the texture and neaten edges.
  - 5. Skip-Troweled Finish with Corner Beads: Even, leveled surface produced by troweling spray-applied finish to smooth out the texture, eliminate surface markings, and square off edges.

### 3.4 FIELD QUALITY CONTROL

- A. Special Inspections: Engage a qualified special inspector to perform the following special inspections:
  - 1. Test and inspect as required by the IBC, Subsection 1705.13, "Sprayed Fire-Resistant Materials."
- B. Perform the tests and inspections of completed Work in successive stages. Do not proceed with application of fireproofing for the next area until test results for previously completed applications of fireproofing show compliance with requirements. Tested values must equal or exceed values as specified and as indicated and required for approved fire-resistance design.
- C. Fireproofing will be considered defective if it does not pass tests and inspections.
  - 1. Remove and replace fireproofing that does not pass tests and inspections, and retest.
  - 2. Apply additional fireproofing, per manufacturer's written instructions, where test results indicate insufficient thickness, and retest.
- D. Prepare test and inspection reports.



### 3.5 CLEANING, PROTECTING, AND REPAIRING

- A. Cleaning: Immediately after completing spraying operations in each containable area of Project, remove material overspray and fallout from surfaces of other construction and clean exposed surfaces to remove evidence of soiling.
- B. Protect fireproofing, according to advice of manufacturer and Installer, from damage resulting from construction operations or other causes, so fireproofing is without damage or deterioration at time of Substantial Completion.
- C. As installation of other construction proceeds, inspect fireproofing and repair damaged areas and fireproofing removed due to work of other trades.
- D. Repair fireproofing damaged by other work before concealing it with other construction.
- E. Repair fireproofing by reapplying it using same method as original installation or using manufacturer's recommended trowel-applied product.

### 3.7 UL ASSEMBLIES & PENETRATIONS

- A. Please see following pages for UL assembly details referenced in drawings.

END OF SECTION

**SECTION 078400 – FIRESTOPPING**

## Part 1 - GENERAL

## 1.1 Summary

- A. Furnish labor, materials, tools, equipment, and services for Firestopping, in accordance with provisions of Contract Documents.
- B. Completely coordinate with work of other trades.

## 1.2 Quality Assurance

- A. Installer Qualifications:
  - 1. Certified, licensed or approved by firestopping manufacturer, trained to install firestop products per specified requirements.
  - 2. Licensed by State or local authority, where applicable.
  - 3. Shown to have successfully completed not less than five (5) comparable scale projects.
- B. Provide firestop systems in compliance with following requirements:
  - 1. Obtain firestop system for each type of penetration and construction condition from a single firestop systems manufacturer.
  - 2. Firestop products and systems shall bear classification marking of qualified testing and inspection agency.
  - 3. Firestopping tests, performed by qualified, testing and inspection agency.
    - a. UL or other agency, performing testing and follow-up inspection services for firestop systems, acceptable to local authorities having jurisdiction.
  - 4. Existing applications for which no tested and listed classified system is available through a manufacturer:
    - a. Provide Engineering Judgment or Equivalent Fire Resistance Rated Assembly (EFERRA) for submittal derived from similar UL system designs or other tests approved by local authorities having jurisdiction, prior to installation.
    - b. Engineering judgment drawings must follow requirements set forth by International Firestop Council.
  - 5. Inspect applied firestopping systems in accordance with International Building Code (IBC) Chapter 17.
    - a. Inspections shall be performed by an FMG 4991 Approved Specialty Contractor/UL Qualified Firestop Contractor and/or ASTM E2174 and ASTM E2393.
    - b. See Section 01 45 23.
  - 6. FM Approved in accordance with FM Standard 4991 – Approval of Firestop Contractors.
  - 7. UL Qualified Firestop Contractor.
- C. Underwriters Laboratories, Inc. (UL):
  - 1. UL 263, Fire Tests of Building Construction and Materials
  - 2. UL 723, Surface Burning Characteristics of Building Materials
  - 3. UL 1479, Fire Tests of Through Penetration Firestops
  - 4. UL 2079, Tests for Fire Resistance of Building Joint Systems
- D. ASTM International (ASTM):
  - 1. ASTM E84 Surface Burning Characteristics of Building Materials
  - 2. ASTM E119 Fire Tests of Building Construction and Materials
  - 3. ASTM E136 Test Method for Behavior of Materials in a Vertical Tube Furnace at 750F

4. ASTM E814 Fire Tests of Through Penetration Fire Stops
  5. ASTM E1399 Cyclic Movement and Measuring the Minimum and Maximum Joint Widths of Architectural Joint Systems
  6. ASTM E1966 Test Method for Fire Resistive Joint Systems
  7. ASTM E2174 Standard Practice for On-site Inspection of Installed Fire Stops
  8. ASTM E2307 Standard Test Method for Determining the Fire Endurance of Perimeter Fire Barrier Systems Using the Intermediate-Scale, Multi Story Test Apparatus (ISMA)
  9. ASTM E2393 Standard Practice for On-site Inspection of Installed Fire Resistive Joint Systems and Perimeter Fire Barriers
  10. ASTM G21 Standard Practice for Determining Resistance of Synthetic Polymeric Materials to Fungi
- E. Building Code as locally adopted and amended.
- F. Underwriters Laboratories (UL) Fire Resistance Directory:
1. Through Penetration Firestop Systems (XHEZ).
  2. Joint Systems (XHBN).
  3. Fill, Void or Cavity Materials (XHHW).
  4. Firestop Devices (XHJI).
  5. Forming Materials (XHKU).
  6. Wall Opening Protective Materials (CLIV).
- G. National Fire Protection Association (NFPA):
1. NFPA 70: National Electrical Code
  2. NFPA 101: Life Safety Code
  3. NFPA 22: Standard for High Challenge Fire Walls, Fire Walls, and Fire Barrier Walls
  4. NFPA 251: Fire Tests of Building Construction and Materials
- H. Firestop Contractors International Association (FCIA): MOP – FCIA Firestop Manual of Practice
- I. International Firestop Council (IFC):
1. Recommended IFC Guidelines for Evaluating Firestop Engineering Judgments, latest revision.
  2. Inspectors Field Pocket Guide, latest edition.
- J. Identification Labels for Firestop Assemblies:
1. Follow guidelines set in Chapter 7 of International Building Code.
  2. Coordinate with Section 04 22 00 and Section 09 29 00.
  3. Label penetration on both sides of wall or slab.
  4. Label each penetration or group of similar penetrations with a permanent label marked with the following information:
    - a. UL system number.
    - b. Rating.
    - c. Products used.
    - d. Installation date.
    - e. Installer name.
    - f. Penetration reference number unique to each location.
- K. Pipe insulation shall not be removed, cut away or otherwise interrupted through wall or floor openings.
1. Provide products appropriately tested for the thickness and type of insulation utilized.
- L. Cabling where frequent cable moves, add-ons, and changes are likely to occur in future:
1. Where cable trays are used:

- a. Utilize re-enterable products (e.g. removable intumescent pillows) specifically designed for retrofit.
  2. Where cable trays are not used:
    - a. Utilize fire-rated cable pathway devices.
    - b. Where not practical, re-enterable products designed for retrofit may be used.
- M. Protect penetrations passing through fire-resistance rated floor-ceiling assemblies contained within chase wall assemblies with products tested by being fully exposed to fire outside of chase wall.
  1. Identify systems within UL Fire Resistance Directory with the words: Chase Wall Optional.
- N. Fire Resistive Joint Sealant:
  1. Provide flexible fire-resistive joint sealants to accommodate normal and thermal building movement without seal damage.
  2. Provide fire-resistive joint sealants designed to accommodate a specific range of movement.
    - a. Test in accordance with cyclic movement test criteria as outlined in: ASTM E1399, ASTM E1966 or UL 2079.
  3. Provide fire-resistive joint systems subjected to an air leakage test.
    - a. Conduct in accordance with UL 2079, with published L-Ratings for ambient and elevated temperatures, as evidence of ability of fire-resistive joint system to restrict movement of smoke.
  4. Coordinate firestopping with acoustical sealant requirements in Section 07 92 16.
- O. Subject smoke wall containment systems to air leakage test.
  1. Conduct in accordance with UL 1479, with published L-Ratings for ambient and elevated temperatures, as evidence of ability of fire-resistive joint system to restrict movement of smoke.
- P. System Description:
  1. Through Penetration Firestop Systems for protection of penetrations through following fire-resistance rated assemblies, including both blank openings and openings containing penetrating items:
    - a. Roof assemblies.
    - b. Floor assemblies.
    - c. Wall and partition assemblies.
    - d. Fire-rated smoke barrier assemblies.
    - e. Existing, fire and smoke-rated assemblies.
    - f. Construction enclosing compartmentalized areas.
  2. Fire Resistive Joint Assemblies for linear voids where fire-rated floor, roof, or wall assemblies abut one another, including following types of joints:
    - a. Top and bottom of wall interface with overhead roof or floor structure:
      - 1) Coordinate with acoustical sealant specified in Section 09 29 00.
      - 2) Select products to maintain acoustical, smoke and fire ratings indicated.
    - b. Non-Fire Rated Expansion Joints: Specified in Section 07 95 13.
    - c. Fire Rated Expansion Joints: Specified in Section 07 95 13.
- Q. LEED Requirements:
  1. Refer to Section 01 81 16, LEED HC v2009 Requirements, for additional performance requirements that may apply to products specified in this section.

### 1.3 SUBMITTALS

- A. Product Data: Manufacturer's standard information indicating certification of products proposed for use on project.

- B. Project Information: UL reports with illustration of systems, system numbers, temperature ratings, and products proposed for use on project.
- C. Contract Closeout Information:
  - 1. Warranty.
  - 2. Electronic file of project firestopping documentation.
  - 3. LEED Information: IEQ 4.1, Low-Emitting Materials, Adhesives and Sealants: Manufacturer's product data for construction adhesives and sealants including VOC content.

#### 1.4 warranty

- A. Written five (5) year warranty guaranteeing quality of installation and meeting requirements of manufacturer's written instructions and tested systems.

### Part 2 - PRODUCTS

#### 2.1 Acceptable manufacturers

- A. Firestopping:
  - a. Hilti, Inc.
- B. Forming Materials:
  - a. Hilti, Inc.

#### 2.2 MATERIALS

- A. Through Penetration Firestop Systems:
  - 1. VOC content not to exceed 250 g/L
  - 2. Base Products:
    - a. FS-ONE Intumescent Firestop Sealant.
    - b. CP 604 Self-leveling Firestop Sealant.
    - c. CP 620 Fire Foam.
    - d. CP 606 Flexible Firestop Sealant.
    - e. CP 601S Elastomeric Firestop Sealant.
- B. Fire-resistive Joints:
  - 1. VOC content not to exceed 250 g/L
  - 2. Base Products:
    - a. CFS-SP WB Firestop Joint Spray.
    - b. CP 601S Elastomeric Firestop Sealant.
    - c. CP 606 Flexible Firestop Sealant.
    - d. CP 604 Self-leveling Firestop Sealant.
- C. Firestop Devices:
  - 1. Factory-assembled collars lined with intumescent material sized to fit specific outside diameter of penetrating item.
  - 2. Base Products:
    - a. CP 680-P Cast-in-Place Firestop Device.
    - b. CP 680-M Cast-in-Place Firestop Device.
    - c. CP 681 Tub Box Kit.
    - d. CFS-DID Firestop Device.
- D. Intumescent Pads, Wall Opening Protective Materials:
  - 1. Intumescent, non-curing pads or inserts for protection of electrical panels, switch and receptacle boxes, medical gas outlets and valve boxes and other items recessed in face of fire rated walls.
  - 2. Base Product:

- a. CFS-P PA Firestop Putty Pad.
  - b. CP 617 Firestop Putty Pad.
  - c. Hilti Biox Insert.
- E. Fire-rated Cable Pathways:
1. Usage:
    - a. Cables passing through fire-rated floors or walls shall pass through fire-rated cable pathway devices made from an intumescent material that adjusts automatically to cable additions or subtractions.
  2. Product description and requirements:
    - a. Pathway device modules comprised of steel raceway and intumescent pads with adjustable smoke seal sleeve.
    - b. F-Rating equal to the rating of barrier the device penetrates.
    - c. Pathway devices shall be capable of allowing a 0 to 100 percent fill of cables.
    - d. Size to accommodate quantity and size of electrical wires and data cables indicated plus 100 percent expansion.
    - e. Provide wire devices with steel wall plates allowing for single or multiple devices ganged together without requiring additional wall structure framing.
  3. Base product:
    - a. CP 653 Speed Sleeve.
      - 1) Use in conjunction with CFS-SL GP when more than one device is required.
    - b. CFS-CC Firestop Cable Collar.
- F. Firestop Putty:
1. Intumescent, non-hardening, water resistant putties containing no solvents, inorganic fibers or silicone compounds.
  2. Firestop putty shall be provided and installed at, but not limited to, the gap between wire, cabling, or both, exiting an open end of conduit, where conduit penetrates one or both sides of a smoke or fire rated wall assembly.
  3. Base products:
    - a. CP 618 Firestop Putty Stick.
    - b. CFS-PL Firestop Plug.
- G. Wrap Strips:
1. Single component intumescent elastomeric strips faced on both sides with a plastic film:
  2. Base Products:
    - a. CP 643N Firestop Collar.
    - b. CP 644 Firestop Collar.
    - c. CP 648E/648S Wrap Strips.
- H. Firestop Blocks:
1. Re-enterable, non-curing, intumescent flexible block.
  2. Base products:
    - a. CFS-BL Fire Block.
    - b. CFS-PL Firestop Plug.
- I. Mortar:
1. Portland cement based dry-mix product formulated for mixing with water at Project site to form a non-shrinking, water-resistant, homogenous mortar.
  2. Base product:
    - a. CP 637 Firestop Mortar.
- J. Silicone Sealants:
1. Moisture curing, single component, silicone elastomeric sealant for horizontal surfaces pourable or nonsag or vertical surface nonsag.
  2. Base product:

- a. CP 601S Elastomeric Firestop Sealant.
    - b. CP 604 Self Leveling Silicone Firestop Sealant.
    - c. CFS-SIL SL Self Leveling Silicone Firestop Sealant.
  - K. Pre-formed mineral wool:
    - 1. CP 767 Speed Strips
    - 2. CP 777 Speed Plugs
  - L. Fire Sealant:
    - 1. Single component latex or acrylic formulations that upon cure do not re-emulsify during exposure to moisture.
      - a. CP 601S Elastic Firestop Sealant.
      - b. CP 606 Fire Resistant Joint Filler.
      - c. CP 672 Firestop Joint Spray.
      - d. CFS-SP WB Firestop Joint Spray.
    - 2. VOC content of sealants shall be no greater than 250 g/L.
    - 3. VOC content of sealants shall be no greater than 250 g/L.
    - 4. Adhesives and sealants shall contain no carcinogen or reproductive toxicant components present at more than 1 percent of total mass of the product as defined in the California Office of Environmental Health Hazard Assessment's (OEHHA) list entitled, Chemicals Known to the State to Cause Cancer, or the Reproductive Toxicity, Safe Drinking Water and Toxic Enforcement Act of 1986 (Proposition 65).
  - M. Composite Sheet:
    - 1. Non-curing, re-penetrable material.
    - 2. Base Products:
      - a. CP 675T Firestop Board.
      - b. CFS-BL FireBlock.
  - N. Forming Materials:
    - 1. Materials listed as components in laboratory-approved designs.
    - 2. Mineral Wool:
      - a. Base Product: CP 767 Speed Strip
      - b. Similar product specifically named as components in laboratory-approved designs.
  - O. Perimeter Fire Containment: Specified in Section 07 84 53.
  - P. Acoustical Sealant: Specified in Section 07 92 16.
- 2.3 THROUGH PENETRATION FIRESTOP SYSTEMS
- A. General:
    - 1. Schedules below identify requirements for acceptable through penetration firestop systems based on barrier type, fire-resistive rating, and penetrant type. Each system must comply with building code and fire code as locally adopted and amended.
    - 2. Requirements for single-membrane penetrations and through penetration firestops are identical. Unless otherwise noted, penetrants which pass through a single membrane, shall be treated the same as if it passed through the entire fire-resistive assembly.
    - 3. Select each firestop system based on actual field conditions, including penetration type, shape, size, quantities and physical position within opening.
    - 4. Refer to Plans for indication of the required ratings of fire-resistive wall, floor, and roof assemblies.
    - 5. Indicated ratings are minimum and may be exceeded.
    - 6. Firestop Assemblies at Fire-Rated Walls:

- a. The minimum Fire (F) Rating for Firestop assemblies in walls shall equal that of the wall, but not less than 1-HR.
  - b. The minimum Temperature (T) Rating of Firestop assemblies in walls may equal zero.
  - c. Smoke Barrier: In addition to (F) Rating, (L) Rating of maximum 5 CFM per SF.
  - d. Non-rated walls and Smoke-Partitions with no fire-resistive requirement: Assembly with (L) rating.
7. Firestop assemblies at fire-rated floors and roofs:
- a. Minimum Fire (F) and Temperature (T) Ratings of Firestop assemblies used in floors or roof shall equal hourly rating of floor or roof being penetrated, but not less than 1-HR.
    - 1) Exception 1: The T-rating may equal zero when portion of penetration, above or below floor, is contained within a wall.
    - 2) Exception 2: Firestops are not required for floor penetrations within a 2-hour rated shaft enclosure.
- B. Voids in wall with no penetrations:
- 1. Fill with approved through penetration firestopping system.
  - 2. Contractor's option: Patch void in wall with like construction.
- C. Penetrating Ducts with Dampers:
- 1. Utilize only firestop materials which are included in damper's classification.
  - 2. Do not install firestop systems that hamper performance of fire dampers.
- D. Cable Trays and similar devices:
- 1. Provide re-enterable products specifically designed for removal and re-installation at openings within walls and floors designed to accommodate voice, data and video cabling.
- E. Electrical panels and devices, medical gas outlets and valve boxes, film illuminators, and other items recessed in to face of rated walls:
- 1. Where electrical devices are placed on opposite sides of wall, and are less than 24 IN apart measured horizontally, install intumescent pads over back of devices in approved manner or maintain continuity of rated barrier within wall cavity surrounding recessed item.
- 2.4 FIRE-RESISTIVE JOINT ASSEMBLIES – GENERAL

A. General:

- 1. Where joint will be exposed to elements, fire-resistive joint sealant must be approved by manufacturer for use in exterior applications and shall comply with ASTM C920.

B. Head-of-Wall Assemblies:

- 1. General:
  - a. Use at top of fire-rated and smoke barrier walls and partitions where they abut floor and roof structures above.
  - b. Select systems with D designation, rated for dynamic movement capability.
  - c. Select systems that can accommodate deflection of structure above.
  - d. Maximum Leakage for Fire-resistive Joints in Smoke Barriers: 5 CFM or less per linear foot as tested in accordance with UL 2079.
  - e. Seal non-fire-rated sound-control walls and smoke partitions with acoustical sealant as specified in Section 07 92 16.
- 2. Minimum F and T ratings:
  - a. The minimum fire rating for firestop assemblies in walls shall equal that of wall, but not less than 1-HR.
  - b. The minimum temperature rating of firestop assemblies in walls may equal zero.
- 3. Acceptable Systems:



- a. Metal stud and drywall partitions: Select system from UL HW-D-0000 Series.
- b. Concrete and Masonry Walls: Select system from UL HW-D-1000 Series.

### Part 3 - EXECUTION

#### 3.1 PREPARATION

- A. Examine areas and conditions under which work is to be performed and identify conditions detrimental to proper or timely completion.
- B. Surfaces to which firestop materials will be applied shall be free of dirt, grease, oil, scale, laitance, rust, release agents, water repellents, and any other substances that may inhibit optimum adhesion.
- C. Provide masking and temporary covering to prevent soiling of adjacent surfaces by firestopping materials.
- D. Do not proceed until unsatisfactory conditions have been corrected.

#### 3.2 Installation

- A. General:
  1. Install firestop systems in accordance with manufacturer's instructions and conditions of testing and classification as specified in UL or other acceptable third-party testing agency listing.
  2. Penetrations through fire-resistive floor assemblies shall be sealed with firestop system providing minimum Class 1 W-rating as tested in accordance with UL 1479 and ensure air and water resistant seal.
  3. Protect materials from damage on surfaces subjected to traffic.
- B. Identification Labels:
  1. Identify each firestop assembly as defined in Quality Assurance.
  2. Do not locate identification labels, tags, or both, on finished surfaces or where exposed to view by public.

#### 3.3 FIELD QUALITY CONTROL

- A. Owner shall engage a qualified independent inspection agency to inspect firestop systems in accordance with ASTM E2174, Standard Practice for On-site Inspection of Installed Fire Stops, and ASTM E2393, Standard Practice for On-Site Inspection of Installed Fire Resistive Joint Systems and Perimeter Fire Barriers.
- B. Construct mock-up on-site to include typical through penetration and fire-resistive joint applications for project.
- C. Maintain areas of work accessible until inspection by authorities having jurisdiction.
- D. Where deficiencies are found, repair or replace assemblies to comply with requirements.

#### 3.4 ADJUSTING AND CLEANING

- A. Remove equipment, materials and debris, leaving area in undamaged, clean condition.
- B. Clean surfaces adjacent to sealed openings free of excess materials and soiling as work progresses.
- C. Perform patching and repair of firestopping systems damaged by other trades.

### END OF SECTION





## System No. C-AJ-1140 XHEZ.C-AJ-1140 Through-penetration Firestop Systems

[Page Bottom](#)

### Design/System/Construction/Assembly Usage Disclaimer

- Authorities Having Jurisdiction should be consulted in all cases as to the particular requirements covering the installation and use of UL Certified products, equipment, system, devices, and materials.
- Authorities Having Jurisdiction should be consulted before construction.
- Fire resistance assemblies and products are developed by the design submitter and have been investigated by UL for compliance with applicable requirements. The published information cannot always address every construction nuance encountered in the field.
- When field issues arise, it is recommended the first contact for assistance be the technical service staff provided by the product manufacturer noted for the design. Users of fire resistance assemblies are advised to consult the general Guide Information for each product category and each group of assemblies. The Guide Information includes specifics concerning alternate materials and alternate methods of construction.
- Only products which bear UL's Mark are considered Certified.

### XHEZ - Through-penetration Firestop Systems

[See General Information for Through-penetration Firestop Systems](#)

#### System No. C-AJ-1140

March 19, 2012

**F Rating — 3 Hr**

**T Rating — 0 Hr**

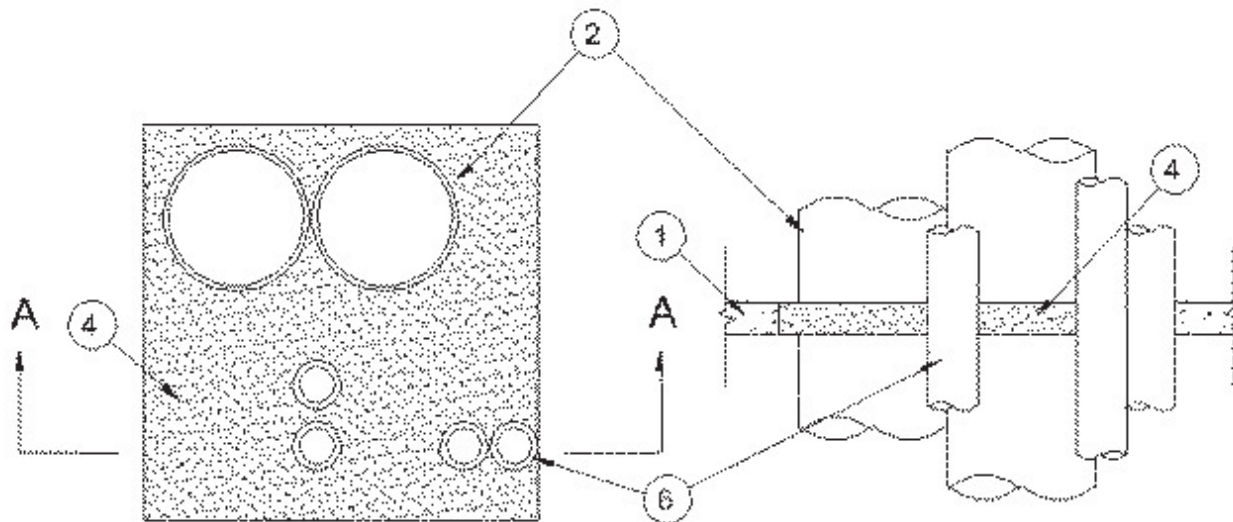

SECTION A-A

**1. Floor or Wall Assembly** — Min 2-1/2 in. (63 mm) thick reinforced lightweight or normal weight (100-150 pcf or 1600-2400 kg/m<sup>3</sup>) concrete. Wall may also be constructed of any UL Classified **Concrete Blocks** \*. Max area of opening is 1024 sq in. (.66 sq m) with max dimension of 32 in. (81.3 cm).

See **Concrete Blocks** (CAZT) category in the Fire Resistance Directory for names of manufacturers.

**2. Through Penetrants** — One or more penetrants to be installed in opening. Min clearance between pipes, conduits or tubing is 0 in. (0 mm). (point contact). Min clearance between pipes, conduit or tubing and periphery of through opening is 1 in. (25 mm). Min clearance between pipes, conduit or tubing and periphery of any single surface of through

opening is 0 in. (point contact). Pipe, conduit or tubing to be rigidly supported on both sides of floor or wall assembly. The following types and sizes of metallic pipes, conduits or tubing may be used:

- A. **Steel Pipe** — Nom 12 in. (305 mm) diam (or smaller) Schedule 10 (or heavier) steel pipe.
  - B. **Conduit** — Nom 4 in. (102 mm) diam (or smaller) steel electrical metallic tubing or steel conduit.
  - C. **Copper Tubing** — Nom 4 in. (102 mm) diam (or smaller) Type L (or heavier) copper tubing.
  - D. **Copper Pipe** — Nom 4 in. (102 mm) diam (or smaller) Regular (or heavier) copper pipe.
3. **Forms** — (Not Shown) — Used as a form to prevent leakage of fill material during installation. Forms to be a rigid sheet material, cut to fit the contour of the penetrating item and positioned as required to accommodate the required thickness of fill material. Forms may be removed after fill material has cured.
4. **Firestop System** — The details of the firestop system shall be as follows:
- A. **Packing Material** — (Optional, Not Shown) - For floors greater than 2-1/2 in. (63 mm) thick, mineral wool batt insulation firmly packed into opening as a permanent or temporary form and recessed from the top surface of floor to accommodate the required thickness of the fill material.
  - B. **Fill, Void or Cavity Material\* — Mortar** — Min 2-1/2 in. (63 mm) thickness of fill material applied within the annulus. Fill material is mixed at a rate of 2.5 parts dry mix to one part water by weight in accordance with the installation instructions supplied with fill material.
- HILTI CONSTRUCTION CHEMICALS, DIV OF HILTI INC** — Type CP636 or CP637

**\* Indicates such products shall bear the UL or cUL Certification Mark for jurisdictions employing the UL or cUL Certification (such as Canada), respectively.**

Last Updated on 2012-03-19

[Questions?](#)

[Print this page](#)

[Terms of Use](#)

[Page Top](#)

© 2015 UL LLC

When the UL Leaf Mark is on the product, or when the word "Environment" is included in the UL Mark, please search the [UL Environment database](#) for additional information regarding this product's certification.

The appearance of a company's name or product in this database does not in itself assure that products so identified have been manufactured under UL's Follow-Up Service. Only those products bearing the UL Mark should be considered to be Certified and covered under UL's Follow-Up Service. Always look for the Mark on the product.

UL permits the reproduction of the material contained in the Online Certification Directory subject to the following conditions: 1. The Guide Information, Assemblies, Constructions, Designs, Systems, and/or Certifications (files) must be presented in their entirety and in a non-misleading manner, without any manipulation of the data (or drawings). 2. The statement "Reprinted from the Online Certifications Directory with permission from UL" must appear adjacent to the extracted material. In addition, the reprinted material must include a copyright notice in the following format: "© 2015 UL LLC".



## System No. C-AJ-1149 XHEZ.C-AJ-1149 Through-penetration Firestop Systems

[Page Bottom](#)

### Design/System/Construction/Assembly Usage Disclaimer

- Authorities Having Jurisdiction should be consulted in all cases as to the particular requirements covering the installation and use of UL Certified products, equipment, system, devices, and materials.
- Authorities Having Jurisdiction should be consulted before construction.
- Fire resistance assemblies and products are developed by the design submitter and have been investigated by UL for compliance with applicable requirements. The published information cannot always address every construction nuance encountered in the field.
- When field issues arise, it is recommended the first contact for assistance be the technical service staff provided by the product manufacturer noted for the design. Users of fire resistance assemblies are advised to consult the general Guide Information for each product category and each group of assemblies. The Guide Information includes specifics concerning alternate materials and alternate methods of construction.
- Only products which bear UL's Mark are considered Certified.

### XHEZ - Through-penetration Firestop Systems

### XHEZ7 - Through-penetration Firestop Systems Certified for Canada

[See General Information for Through-penetration Firestop Systems](#)

[See General Information for Through-penetration Firestop Systems Certified for Canada](#)

### System No. C-AJ-1149

February 20, 2015

ANSI/UL1479 (ASTM E814)	CAN/ULC S115
F Rating — 2 Hr	F Rating — 2 Hr
T Rating — 0 Hr	FT Rating — 0 Hr
L Rating At Ambient — Less Than 1 CFM/sq ft	FH Rating — 2 Hr
L Rating At 400 F — 4 CFM/sq ft	FTH Rating — 0 Hr
W Rating — Class 1 (See Item 4)	L Rating At Ambient — Less Than 1 CFM/sq ft
	L Rating At 400 F — 4 CFM/sq ft

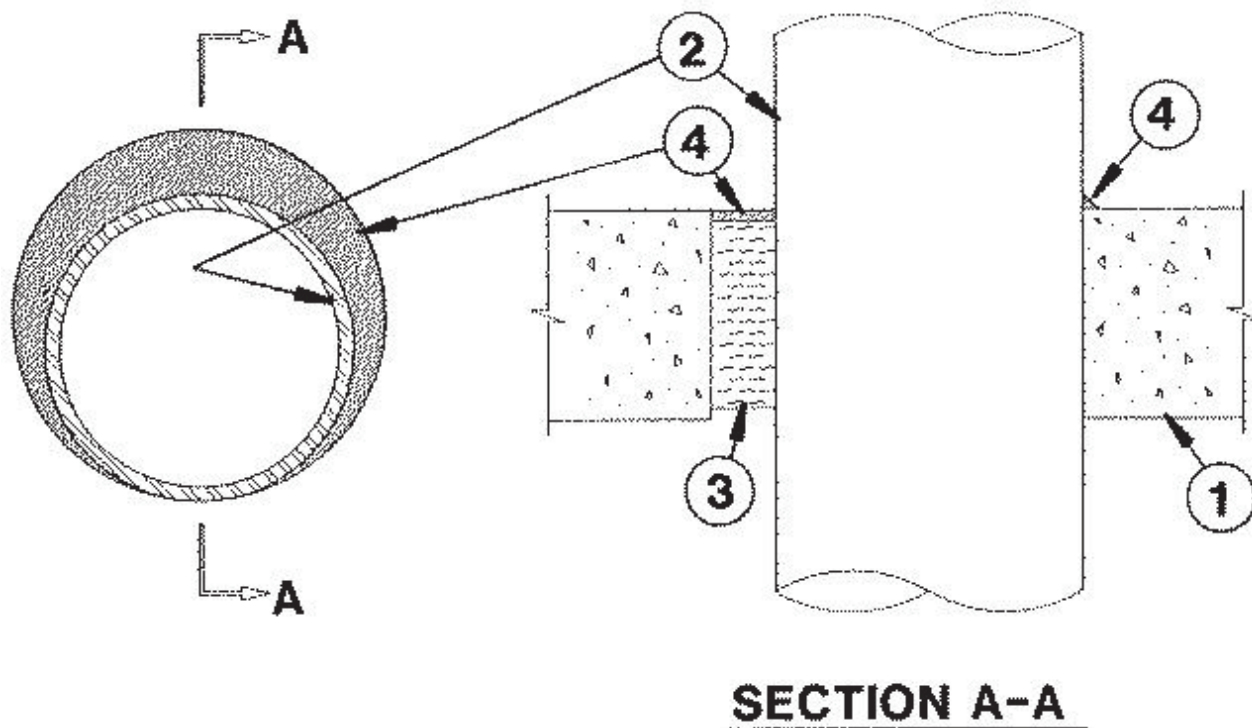

1. **Floor or Wall Assembly** — Min 4-1/2 in. (114 mm) thick reinforced lightweight or normal weight (100-150 pcf or 1600-2400 kg/m<sup>3</sup>) concrete. Wall may also be constructed of any UL Classified **Concrete Blocks** \*. Max diam of opening is 12 in. (305 mm).

See **Concrete Blocks** (CAZT) category in the Fire Resistance Directory for names of manufacturers.

2. **Through Penetrants** — One metallic pipe, conduit or tubing to be installed within the firestop system. Pipe, conduit or tubing to be rigidly supported on both sides of floor or wall assembly. The annular space shall be 0 in. (point contact) to max 1-1/4 in. (32 mm). The following types and sizes of metallic pipes, conduits or tubing may be used:

- A. **Steel Pipe** — Nom 10 in. (254 mm) diam (or smaller) Schedule 10 (or heavier) steel pipe.
- B. **Iron Pipe** — Nom 10 in. (254 mm) diam (or smaller) cast or ductile iron pipe.
- C. **Conduit** — Nom 4 in. (102 mm) diam (or smaller) steel electrical metallic tubing or steel conduit.
- D. **Copper Tubing** — Nom 4 in. (102 mm) diam (or smaller) Type L (or heavier) copper tubing.
- E. **Copper Pipe** — Nom 4 in. (102 in.) diam (or smaller) Regular (or heavier) copper pipe.

3. **Packing Material** — Min 3 in. (76 mm) thickness of min 4 pcf (64 kg/m<sup>3</sup>) mineral wool batt insulation for nom 4 in. diam (and smaller) pipes, conduits or tubings and a min 4 in. (102 mm) thickness of min 4 pcf (64 kg/m<sup>3</sup>) mineral wool batt insulation for pipe greater than nom 4 in. diam, firmly packed into opening as a permanent form. Packing material to be recessed from top surface of floor or from both surfaces of wall to accommodate the required thickness of fill material.

4. **Fill, Void or Cavity Material\* — Sealant** — Min 1/2 in. (13 mm) thickness of fill material applied within the annulus, flush with the top surface of floor or both surfaces of wall. At the point of contact location between pipe and concrete, a min 1/2 in. (13 mm) diam bead of fill material shall be applied at the concrete/pipe interface on the top surface of floor and on both surfaces of wall. **W Rating applies only when CFS-S SIL GG, CFS-S SIL SL (floors only), CP601S, CP604 sealant or FS-ONE MAX Intumescent Sealant is used. For W Rating when FS-ONE MAX is used, packing material to be a min 4 in. (102 mm) thickness of min 4 pcf (64 kg/m<sup>3</sup>) mineral wool batt insulation.**

**HILTI CONSTRUCTION CHEMICALS, DIV OF HILTI INC** — CP601S, CP604, CFS-S SIL GG, CFS-S SIL SL (floors only), CP606 or FS-ONE Sealant or FS-ONE MAX Intumescent Sealant.

\* Indicates such products shall bear the UL or cUL Certification Mark for jurisdictions employing the UL or cUL Certification (such as Canada), respectively.

Last Updated on 2015-02-20

[Questions?](#)

[Print this page](#)

[Terms of Use](#)

[Page Top](#)

When the UL Leaf Mark is on the product, or when the word "Environment" is included in the UL Mark, please search the [UL Environment database](#) for additional information regarding this product's certification.

The appearance of a company's name or product in this database does not in itself assure that products so identified have been manufactured under UL's Follow-Up Service. Only those products bearing the UL Mark should be considered to be Certified and covered under UL's Follow-Up Service. Always look for the Mark on the product.

UL permits the reproduction of the material contained in the Online Certification Directory subject to the following conditions: 1. The Guide Information, Assemblies, Constructions, Designs, Systems, and/or Certifications (files) must be presented in their entirety and in a non-misleading manner, without any manipulation of the data (or drawings). 2. The statement "Reprinted from the Online Certifications Directory with permission from UL" must appear adjacent to the extracted material. In addition, the reprinted material must include a copyright notice in the following format: "© 2015 UL LLC".



## System No. C-AJ-1155 XHEZ.C-AJ-1155 Through-penetration Firestop Systems

[Page Bottom](#)

### Design/System/Construction/Assembly Usage Disclaimer

- Authorities Having Jurisdiction should be consulted in all cases as to the particular requirements covering the installation and use of UL Certified products, equipment, system, devices, and materials.
- Authorities Having Jurisdiction should be consulted before construction.
- Fire resistance assemblies and products are developed by the design submitter and have been investigated by UL for compliance with applicable requirements. The published information cannot always address every construction nuance encountered in the field.
- When field issues arise, it is recommended the first contact for assistance be the technical service staff provided by the product manufacturer noted for the design. Users of fire resistance assemblies are advised to consult the general Guide Information for each product category and each group of assemblies. The Guide Information includes specifics concerning alternate materials and alternate methods of construction.
- Only products which bear UL's Mark are considered Certified.

### XHEZ - Through-penetration Firestop Systems

### XHEZ7 - Through-penetration Firestop Systems Certified for Canada

[See General Information for Through-penetration Firestop Systems](#)

[See General Information for Through-penetration Firestop Systems Certified for Canada](#)

### System No. C-AJ-1155

February 20, 2015

ANSI/UL1479 (ASTM E814)	CAN/ULC S115
F Rating — 2 and 3 Hr (See Item 3)	F Rating — 2 and 3 Hr (See Item 3)
T Rating — 0 Hr	FT Rating — 0 Hr
L Rating At Ambient — Less Than 1 CFM/sq ft	FH Rating — 2 and 3 Hr (See Item 3)
L Rating At 400 F — 4 CFM/sq ft	FTH Rating — 0 Hr
W Rating — Class 1 (See Item 4)	L Rating At Ambient — Less Than 1 CFM/sq ft
	L Rating At 400 F — 4 CFM/sq ft



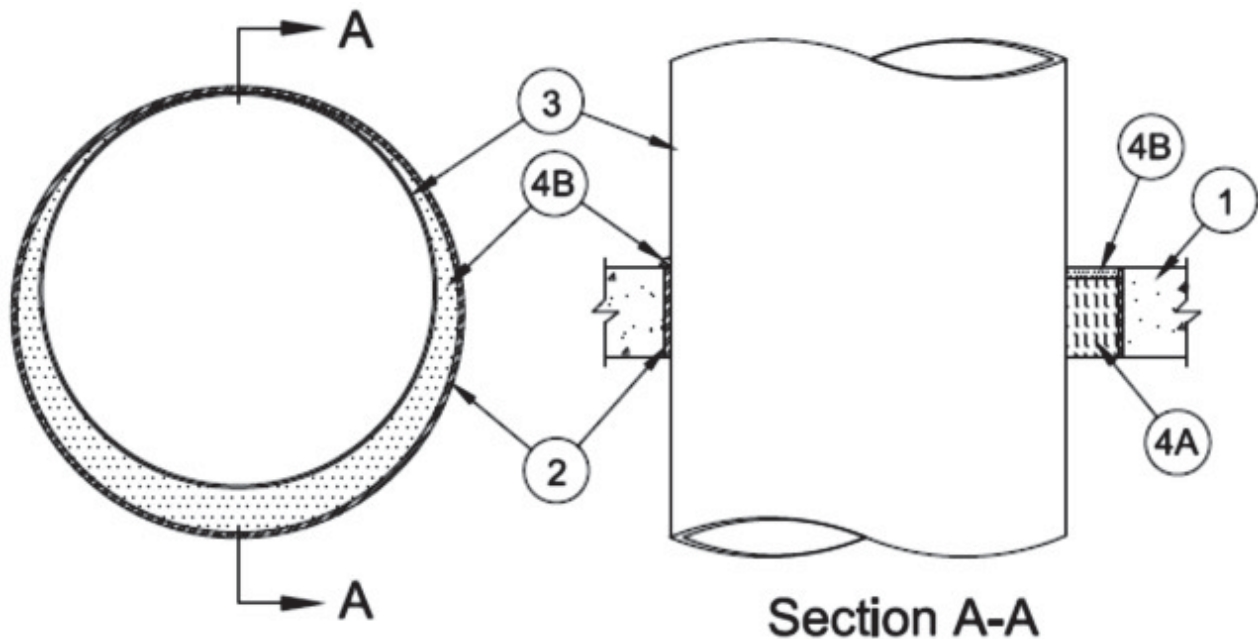

1. **Floor or Wall Assembly** — Min 4-1/2 in. (114 mm) thick reinforced lightweight or normal weight (100-150 pcf or 1600-2400 kg/m<sup>3</sup>) concrete. Wall may also be constructed of any UL Classified **Concrete Blocks\***. Max diam of opening is 32 in. (813 mm).

See **Concrete Blocks** (CAZT) category in Fire Resistance Directory for names of manufacturers.

2. **Metallic Sleeve (Optional)** — Nom 32 in. (813 mm) diam (or smaller) Schedule 40 (or heavier) steel pipe cast or grouted into floor or wall assembly, flush with floor or wall assembly.

3. **Through Penetrants** — One metallic pipe or tubing to be installed either concentrically or eccentrically within the firestop system. Pipe or tubing to be rigidly supported on both sides of floor or wall assembly. The annular space shall be min 0 in. (point contact) to max 12 in. (305 mm). **When maximum annular space exceeds 2-1/4 in. (57 mm) the F Rating is 2 hr.** The following types and sizes of metallic pipes or tubing may be used:

A. **Steel Pipe** — Nom 20 in. (508 mm) diam (or smaller) Schedule 10 (or heavier) steel pipe.

B. **Iron Pipe** — Nom 20 in. (508 mm) diam (or smaller) cast or ductile iron pipe.

C. **Conduit** — Nom 4 in. (102 mm) diam (or smaller) steel electrical metallic tubing or nom 6 in. (152 mm) diam (or smaller) steel electrical metallic tubing or nom 6 in. (152 mm) diam (or smaller) steel conduit.

D. **Copper Tubing** — Nom 6 in. (152 mm) diam (or smaller) Type L (or heavier) copper tubing.

E. **Copper Pipe** — Nom 6 in. (152 mm) diam (or smaller) Regular (or heavier) copper pipe

4. **Firestop System** — The firestop system shall consist of the following:

A. **Packing Material** — Min 4 in. (102 mm) thickness of min 4 pcf (64 kg/m<sup>3</sup>) mineral wool batt insulation firmly packed into opening as a permanent form. Packing material to be recessed from top end of sleeve for floors or from both ends of sleeve for walls to accommodate the required thickness of fill material.

B. **Fill, Void or Cavity Material\* — Sealant** — Min 1/2 in. (13 mm) thickness of fill material applied within the annulus, flush with the top end of the sleeve for floors, or with both ends of the sleeve for walls. Min 1/2 in. (13 mm) thick bead of all material to be installed around pipe at interface of sleeve for point contact installations. **W Rating applies only when FS-ONE MAX Intumescent Sealant is used. For the W Rating, max annular space is 1-7/8 in. (48 mm) and an additional film of sealant shall be applied over the sleeve (when used) lapping at least 1/2 in. (13 mm) onto top surface of floor or both surfaces of wall.**

**HILTI CONSTRUCTION CHEMICALS, DIV OF HILTI INC** — FS-ONE Sealant or FS-ONE MAX Intumescent Sealant

\* Indicates such products shall bear the UL or cUL Certification Mark for jurisdictions employing the UL or cUL Certification (such as Canada), respectively.

Last Updated on 2015-02-20

[Questions?](#)

[Print this page](#)

[Terms of Use](#)

[Page Top](#)

When the UL Leaf Mark is on the product, or when the word "Environment" is included in the UL Mark, please search the [UL Environment database](#) for additional information regarding this product's certification.

The appearance of a company's name or product in this database does not in itself assure that products so identified have been manufactured under UL's Follow-Up Service. Only those products bearing the UL Mark should be considered to be Certified and covered under UL's Follow-Up Service. Always look for the Mark on the product.

UL permits the reproduction of the material contained in the Online Certification Directory subject to the following conditions: 1. The Guide Information, Assemblies, Constructions, Designs, Systems, and/or Certifications (files) must be presented in their entirety and in a non-misleading manner, without any manipulation of the data (or drawings). 2. The statement "Reprinted from the Online Certifications Directory with permission from UL" must appear adjacent to the extracted material. In addition, the reprinted material must include a copyright notice in the following format: "© 2015 UL LLC".



## System No. C-AJ-1276 XHEZ.C-AJ-1276 Through-penetration Firestop Systems

[Page Bottom](#)

### Design/System/Construction/Assembly Usage Disclaimer

- Authorities Having Jurisdiction should be consulted in all cases as to the particular requirements covering the installation and use of UL Certified products, equipment, system, devices, and materials.
- Authorities Having Jurisdiction should be consulted before construction.
- Fire resistance assemblies and products are developed by the design submitter and have been investigated by UL for compliance with applicable requirements. The published information cannot always address every construction nuance encountered in the field.
- When field issues arise, it is recommended the first contact for assistance be the technical service staff provided by the product manufacturer noted for the design. Users of fire resistance assemblies are advised to consult the general Guide Information for each product category and each group of assemblies. The Guide Information includes specifics concerning alternate materials and alternate methods of construction.
- Only products which bear UL's Mark are considered Certified.

### XHEZ - Through-penetration Firestop Systems

### XHEZ7 - Through-penetration Firestop Systems Certified for Canada

[See General Information for Through-penetration Firestop Systems](#)

[See General Information for Through-penetration Firestop Systems Certified for Canada](#)

### System No. C-AJ-1276

April 20, 2012

ANSI/UL1479 (ASTM E814)	CAN/ULC S115
F Rating — 3 Hr	F Rating — 3 Hr
T Rating — 0 Hr	FT Rating — 0 Hr
	FH Rating — 3 Hr
	FTH Rating — 0 Hr

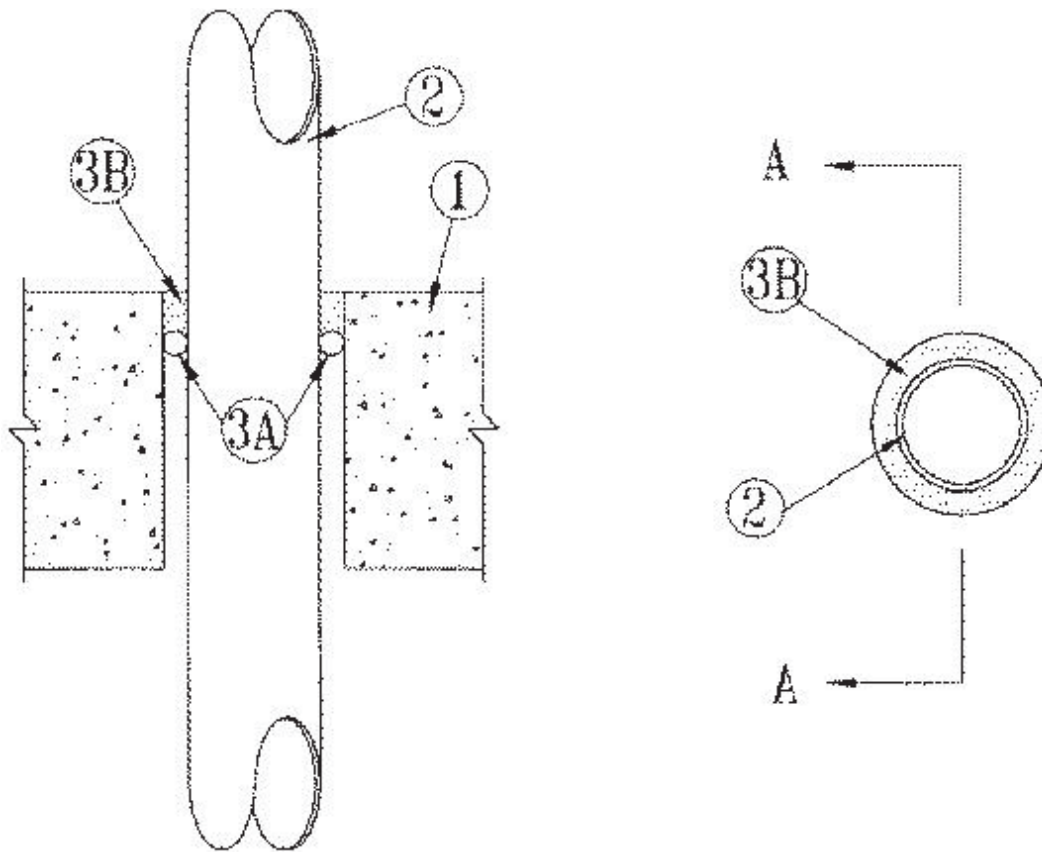

### SECTION A-A

1. **Floor or Wall Assembly** — Min 4-1/2 in. (114 mm) thick reinforced lightweight or normal weight (100-150 pcf or 1600-2400 kg/m<sup>3</sup>) concrete. Wall may also be constructed of any UL Classified **Concrete Blocks\***. Max diam of opening is 6 in. (152 mm).

See **Concrete Blocks** (CAZT) category in the Fire Resistance Directory for names of manufacturers.

2. **Through Penetrants** — One metallic pipe, conduit or tubing to be centered within the firestop system. A nom annular space of 3/4 in. (19 mm) is required within the firestop system. Pipe, conduit or tubing to be rigidly supported on both sides of floor or wall assembly. The following types and sizes of metallic pipes, conduits or tubing may be used:

- A. **Steel Pipe** — Nom 4 in. (102 mm) diam (or smaller) Schedule 10 (or heavier) steel pipe.
- B. **Conduit** — Nom 4 in. (102 mm) diam (or smaller) steel electrical metallic tubing or steel conduit.

3. **Firestop System** — The firestop system shall consist of the following:

A. **Packing or Forming Materials** — Optional — One of the following packing or forming materials may be used:

A1. **Foam Backer Rod** — Foam backer rod tightly packed into the opening as a permanent form. Packing material to be recessed from the top surface of floor or both surfaces of wall as required to accommodate the required thickness of putty.

A2. **Mineral Wool Batt Insulation** — Min 4 pcf (64 kg/m<sup>3</sup>), tightly packed into the opening as a permanent form. Packing material to be recessed from the top surface of floor or both surfaces of wall as required to accommodate the required thickness of putty.

A3. **Forming Material\*** — Forming material to be foamed into the opening as a permanent form. Forming material to be recessed from the top surface of floor or both surfaces of wall as required to accommodate the required thickness of putty.

**HILTI CONSTRUCTION CHEMICALS, DIV OF HILTI INC** — CF812 or CF-AS CJP Foam Sealant

B. **Fill, Void or Cavity Material\* — Putty** — Min 1 in. (25 mm) thickness of putty applied within the annulus, flush with top surface of floor or with both surfaces of wall.

**HILTI CONSTRUCTION CHEMICALS, DIV OF HILTI INC** — CP 618 Firestop Putty Stick

**\* Indicates such products shall bear the UL or cUL Certification Mark for jurisdictions employing the UL or cUL Certification (such as Canada), respectively.**

Last Updated on 2012-04-20

---

[Questions?](#)

[Print this page](#)

[Terms of Use](#)

[Page Top](#)

© 2015 UL LLC

When the UL Leaf Mark is on the product, or when the word "Environment" is included in the UL Mark, please search the [UL Environment database](#) for additional information regarding this product's certification.

The appearance of a company's name or product in this database does not in itself assure that products so identified have been manufactured under UL's Follow-Up Service. Only those products bearing the UL Mark should be considered to be Certified and covered under UL's Follow-Up Service. Always look for the Mark on the product.

UL permits the reproduction of the material contained in the Online Certification Directory subject to the following conditions: 1. The Guide Information, Assemblies, Constructions, Designs, Systems, and/or Certifications (files) must be presented in their entirety and in a non-misleading manner, without any manipulation of the data (or drawings). 2. The statement "Reprinted from the Online Certifications Directory with permission from UL" must appear adjacent to the extracted material. In addition, the reprinted material must include a copyright notice in the following format: "© 2015 UL LLC".



## System No. C-AJ-1277 XHEZ.C-AJ-1277 Through-penetration Firestop Systems

[Page Bottom](#)

### Design/System/Construction/Assembly Usage Disclaimer

- Authorities Having Jurisdiction should be consulted in all cases as to the particular requirements covering the installation and use of UL Certified products, equipment, system, devices, and materials.
- Authorities Having Jurisdiction should be consulted before construction.
- Fire resistance assemblies and products are developed by the design submitter and have been investigated by UL for compliance with applicable requirements. The published information cannot always address every construction nuance encountered in the field.
- When field issues arise, it is recommended the first contact for assistance be the technical service staff provided by the product manufacturer noted for the design. Users of fire resistance assemblies are advised to consult the general Guide Information for each product category and each group of assemblies. The Guide Information includes specifics concerning alternate materials and alternate methods of construction.
- Only products which bear UL's Mark are considered Certified.

### XHEZ - Through-penetration Firestop Systems

#### XHEZ7 - Through-penetration Firestop Systems Certified for Canada

[See General Information for Through-penetration Firestop Systems](#)

[See General Information for Through-penetration Firestop Systems Certified for Canada](#)

### System No. C-AJ-1277

April 20, 2012

ANSI/UL1479 (ASTM E814)	CAN/ULC S115
F Rating — 3 Hr	F Rating — 3 Hr
T Rating — 1/2 Hr	FT Rating — 1/2 Hr
	FH Rating — 3 Hr
	FTH Rating — 1/2 Hr

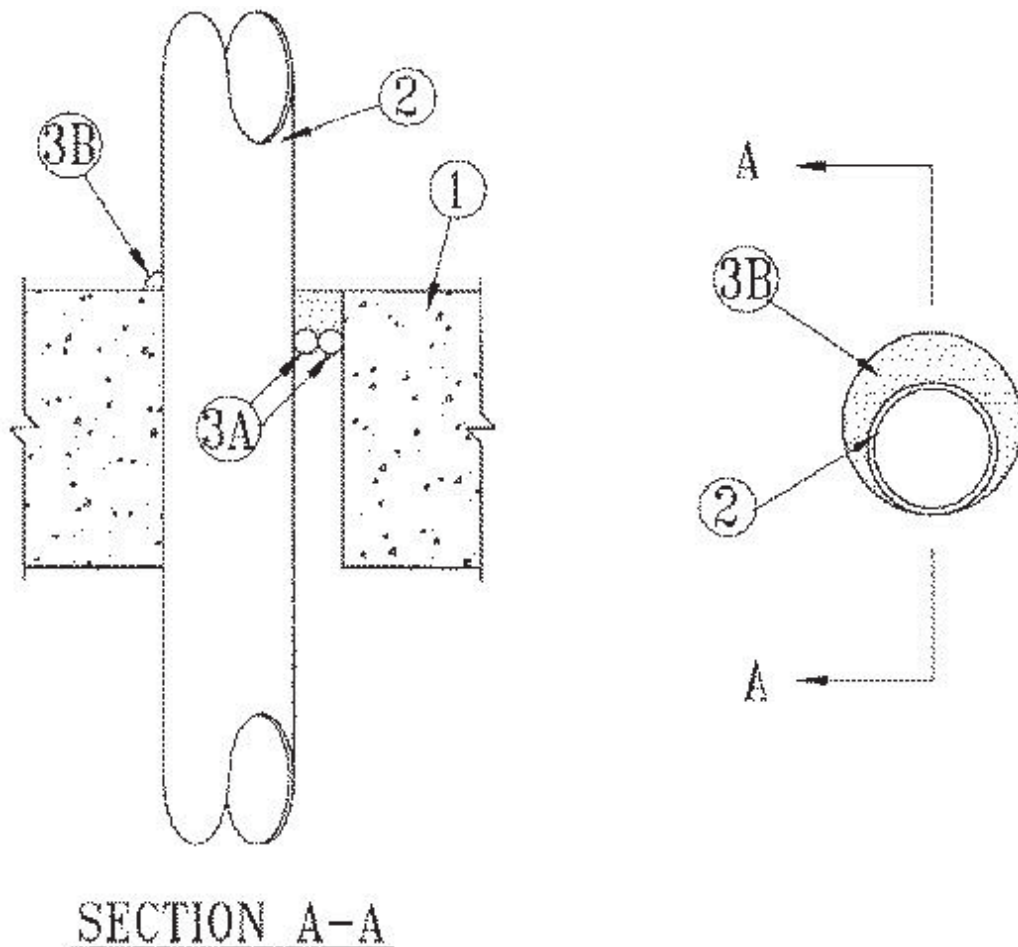

1. **Floor or Wall Assembly** — Min 4-1/2 in. (114 mm) thick reinforced lightweight or normal weight (100-150 pcf or 1600-2400 kg/m<sup>3</sup>) concrete. Wall may also be constructed of any UL Classified **Concrete Blocks\***. Max diam of opening is 4 in. (102 mm).

See **Concrete Blocks** (CAZT) category in the Fire Resistance Directory for names of manufacturers.

2. **Through Penetrants** — One metallic pipe, conduit or tubing to be installed either concentrically or eccentrically within the firestop system. The annular space shall be min 0 in. (point contact) to max 1-13/16 in. (46 mm). Pipe or conduit to be rigidly supported on both sides of floor or wall assembly. The following types and sizes of metallic pipes or conduits may be used:

- A. **Steel Pipe** — Nom 2 in. (51 mm) diam (or smaller) Schedule 40 (or heavier) steel pipe.
- B. **Iron Pipe** — Nom 2 in. (51 mm) diam (or smaller) cast or ductile iron pipe.
- C. **Conduit** — Nom 2 in. (51 mm) diam (or smaller) steel electrical metallic tubing or steel conduit.

3. **Firestop System** — The firestop system shall consist of the following:

A. **Packing or Forming Materials** — One of the following packing or forming materials may be used:

- A1. **Foam Backer Rod** — Tightly packed into the opening as a permanent form. Packing material to be recessed from the top surface of floor or both surfaces of wall as required to accommodate the required thickness of putty.
- A2. **Mineral Wool Batt Insulation** — Min 4 pcf (64 kg/m<sup>3</sup>), tightly packed into the opening as a permanent form. Packing material to be recessed from the top surface of floor or both surfaces of wall as required to accommodate the required thickness of putty.
- A3. **Forming Materials\*** — Forming material to be foamed into the opening as a permanent form. Forming material to be recessed from the top surface of floor or both surfaces of wall as required to accommodate the required thickness of putty.

**HILTI CONSTRUCTION CHEMICALS, DIV OF HILTI INC** — CF812 or CF-AS CJP Foam Sealant

B. **Fill, Void or Cavity Material\* — Putty** — Min 3/4 in. (19 mm) thickness of putty applied within the annulus, flush with top surface of floor or with both surfaces of wall. At the point contact location between pipe and concrete, a min 1/4 in. (6 mm) diam bead of fill material shall be applied at the concrete/pipe interface on the top surface of floor and on both surfaces

of wall.

**HILTI CONSTRUCTION CHEMICALS, DIV OF HILTI INC** — CP 618 Firestop Putty Stick

**\* Indicates such products shall bear the UL or cUL Certification Mark for jurisdictions employing the UL or cUL Certification (such as Canada), respectively.**

Last Updated on 2012-04-20

---

[Questions?](#)

[Print this page](#)

[Terms of Use](#)

[Page Top](#)

© 2015 UL LLC

When the UL Leaf Mark is on the product, or when the word "Environment" is included in the UL Mark, please search the [UL Environment database](#) for additional information regarding this product's certification.

The appearance of a company's name or product in this database does not in itself assure that products so identified have been manufactured under UL's Follow-Up Service. Only those products bearing the UL Mark should be considered to be Certified and covered under UL's Follow-Up Service. Always look for the Mark on the product.

UL permits the reproduction of the material contained in the Online Certification Directory subject to the following conditions: 1. The Guide Information, Assemblies, Constructions, Designs, Systems, and/or Certifications (files) must be presented in their entirety and in a non-misleading manner, without any manipulation of the data (or drawings). 2. The statement "Reprinted from the Online Certifications Directory with permission from UL" must appear adjacent to the extracted material. In addition, the reprinted material must include a copyright notice in the following format: "© 2015 UL LLC".





## System No. C-AJ-1278 XHEZ.C-AJ-1278 Through-penetration Firestop Systems

[Page Bottom](#)

### Design/System/Construction/Assembly Usage Disclaimer

- Authorities Having Jurisdiction should be consulted in all cases as to the particular requirements covering the installation and use of UL Certified products, equipment, system, devices, and materials.
- Authorities Having Jurisdiction should be consulted before construction.
- Fire resistance assemblies and products are developed by the design submitter and have been investigated by UL for compliance with applicable requirements. The published information cannot always address every construction nuance encountered in the field.
- When field issues arise, it is recommended the first contact for assistance be the technical service staff provided by the product manufacturer noted for the design. Users of fire resistance assemblies are advised to consult the general Guide Information for each product category and each group of assemblies. The Guide Information includes specifics concerning alternate materials and alternate methods of construction.
- Only products which bear UL's Mark are considered Certified.

### XHEZ - Through-penetration Firestop Systems

#### XHEZ7 - Through-penetration Firestop Systems Certified for Canada

[See General Information for Through-penetration Firestop Systems](#)

[See General Information for Through-penetration Firestop Systems Certified for Canada](#)

### System No. C-AJ-1278

January 07, 2015

ANSI/UL1479 (ASTM E814)	CAN/ULC S115
F Rating - 3 Hr	F Rating - 3 Hr
T Rating - 0 Hr	FT Rating - 0 Hr
	FH Rating - 3 Hr
	FTH Rating - 0 Hr

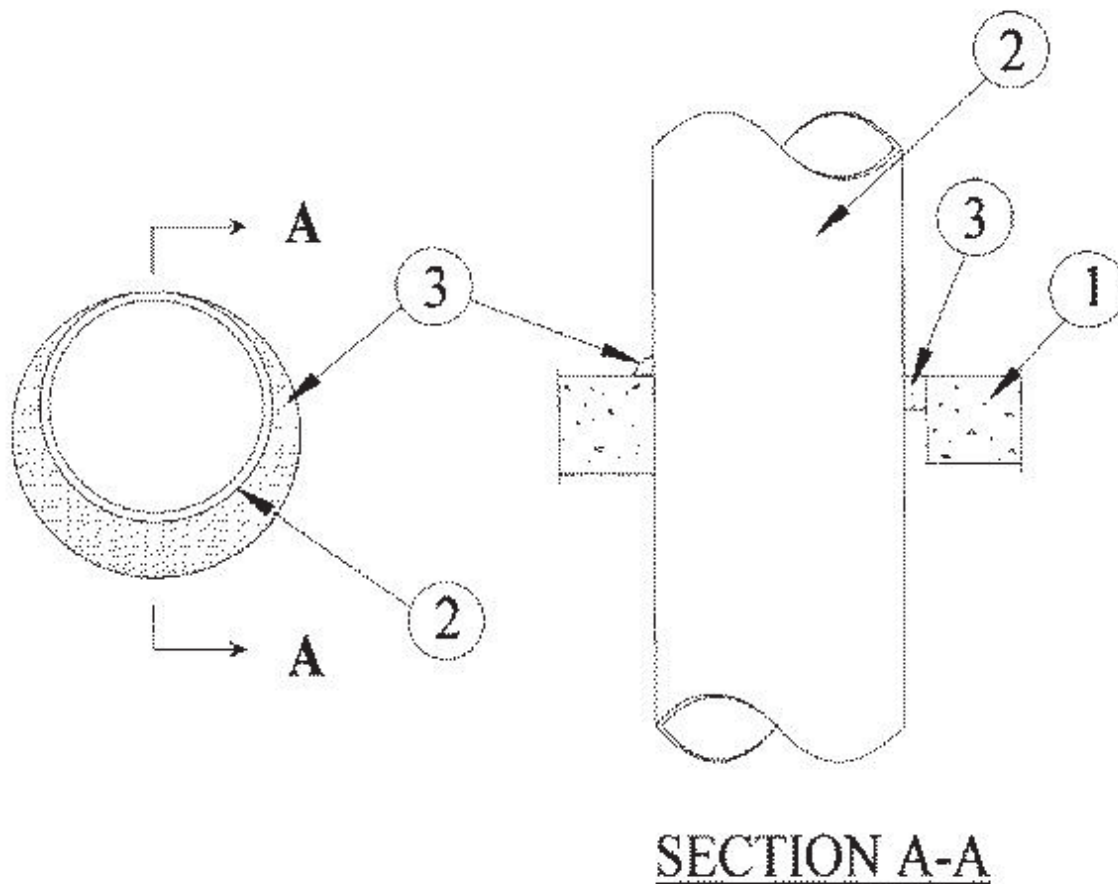

1. **Floor or Wall assembly** — Minimum 4-1/2 in. (114 mm) thick reinforced lightweight or normal weight (100-150 pcf or 1600-2400 kg/m<sup>3</sup>) concrete. Wall may also be constructed of any UL Classified **Concrete Blocks\***. Maximum diameter of opening is 30-7/8 in. (784 mm).

See **Concrete Blocks** (CAZT) category in the Fire Resistance Directory for names of manufacturers.

2. **Through-Penetrant** — One metallic pipe or conduit to be installed either concentrically or eccentrically within the firestop system. The annular space between pipe or conduit and periphery of opening shall be minimum 0 in. to maximum 7/8 in. (22 mm). Pipe or conduit to be rigidly supported on both sides of floor or wall assembly. The following types and sizes of metallic pipes or conduits may be used:

- A. **Steel Pipe** — Nominally 30 in. (762 mm) diameter (or smaller) Schedule 10 (or heavier) steel pipe.
- B. **Copper Pipe** — Nominally 6 in. (152 mm) diameter (or smaller) Regular (or heavier) copper pipe.
- C. **Copper Tubing** — Nominally 6 in. (152 mm) diameter (or smaller) Type L (or heavier) copper tubing.
- D. **Conduit** — Nominally 6 in. (152 mm) diameter (or smaller) steel conduit.
- E. **Conduit** — Nominally 4 in. (102 mm) diameter (or smaller) steel electrical metallic tubing (EMT).

3. **Fill, Void or Cavity Material\* — Sealant** — Minimum 1/2 in. (13 mm) thickness of fill material applied within the annulus, flush with top surface of floor or with both surfaces of wall. At the point contact location between pipe and concrete, a minimum 1/4 in. (6 mm) diameter bead of fill material shall be applied at the concrete/pipe interface on the top surface of floor and on both surfaces of wall.

**HILTI CONSTRUCTION CHEMICALS, DIV OF HILTI INC** — FS-ONE Sealant or FS-ONE MAX Intumescent Sealant

\* Indicates such products shall bear the UL or cUL Certification Mark for jurisdictions employing the UL or cUL Certification (such as Canada), respectively.

Last Updated on 2015-01-07

[Questions?](#)

[Print this page](#)

[Terms of Use](#)

[Page Top](#)

When the UL Leaf Mark is on the product, or when the word "Environment" is included in the UL Mark, please search the [UL Environment database](#) for additional information regarding this product's certification.

The appearance of a company's name or product in this database does not in itself assure that products so identified have been manufactured under UL's Follow-Up Service. Only those products bearing the UL Mark should be considered to be Certified and covered under UL's Follow-Up Service. Always look for the Mark on the product.

UL permits the reproduction of the material contained in the Online Certification Directory subject to the following conditions: 1. The Guide Information, Assemblies, Constructions, Designs, Systems, and/or Certifications (files) must be presented in their entirety and in a non-misleading manner, without any manipulation of the data (or drawings). 2. The statement "Reprinted from the Online Certifications Directory with permission from UL" must appear adjacent to the extracted material. In addition, the reprinted material must include a copyright notice in the following format: "© 2015 UL LLC".



## System No. C-AJ-2118 XHEZ.C-AJ-2118 Through-penetration Firestop Systems

[Page Bottom](#)

### Design/System/Construction/Assembly Usage Disclaimer

- Authorities Having Jurisdiction should be consulted in all cases as to the particular requirements covering the installation and use of UL Certified products, equipment, system, devices, and materials.
- Authorities Having Jurisdiction should be consulted before construction.
- Fire resistance assemblies and products are developed by the design submitter and have been investigated by UL for compliance with applicable requirements. The published information cannot always address every construction nuance encountered in the field.
- When field issues arise, it is recommended the first contact for assistance be the technical service staff provided by the product manufacturer noted for the design. Users of fire resistance assemblies are advised to consult the general Guide Information for each product category and each group of assemblies. The Guide Information includes specifics concerning alternate materials and alternate methods of construction.
- Only products which bear UL's Mark are considered Certified.

### XHEZ - Through-penetration Firestop Systems

[See General Information for Through-penetration Firestop Systems](#)

#### System No. C-AJ-2118

January 27, 2015

**F Rating — 3 Hr**

**T Rating — 0 Hr**

**L Rating At Ambient — Less Than 1 CFM/sq ft**

**L Rating At 400 F — 4 CFM/sq ft**

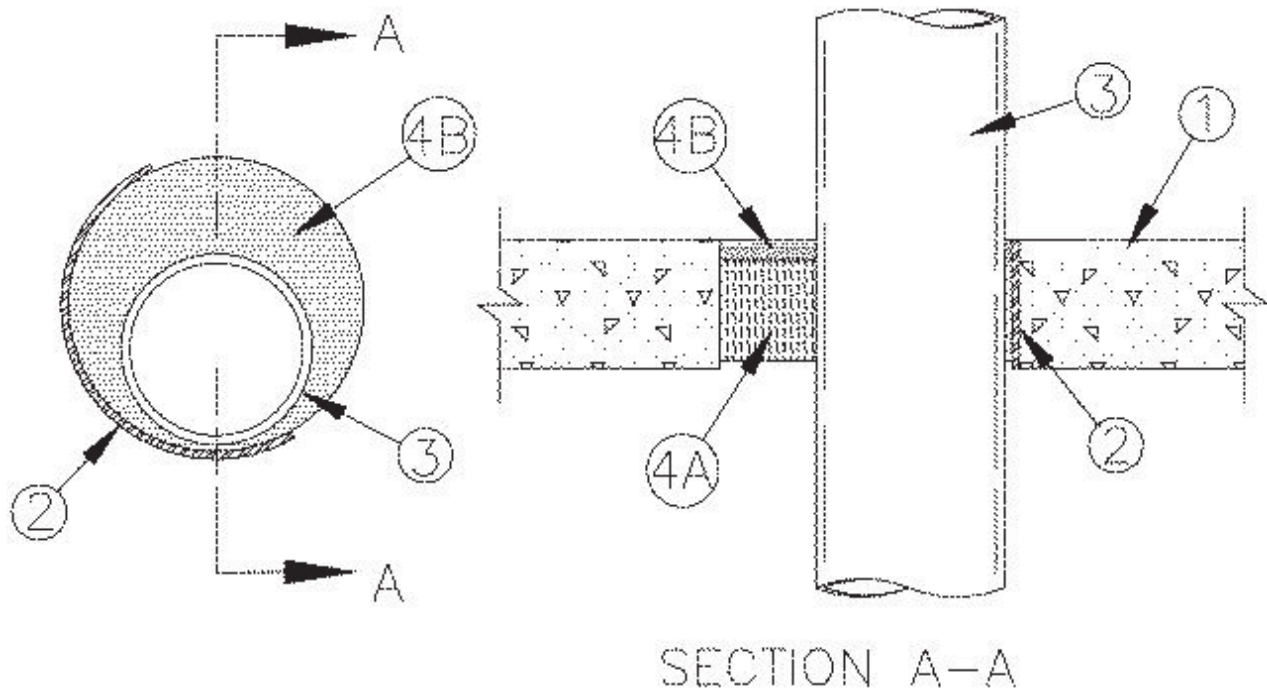

1. **Floor or Wall Assembly** — Min 4-1/2 in. (114 mm) thick reinforced lightweight or normal weight (100-150 pcf or 1600-2400 kg/m<sup>3</sup>) concrete floor or min 5 in. (127 mm) thick reinforced lightweight or normal weight concrete wall. Wall may also be constructed of any UL Classified **Concrete Blocks\***. Max diam of opening is 10 in. (254 mm).

See **Concrete Blocks** (CAZT) category in the Fire Resistance Directory for names of manufacturers.

2. **Metallic Sleeve** — (Optional) — Nom 10 in. (254 mm) diam (or smaller) Sch 10 (or heavier) steel pipe cast or grouted into floor or wall assembly, flush with floor or wall surfaces.

3. **Through-Penetrants\* — Glass Pipe** — Nom 6 in. (152 mm) diam (or smaller) glass pipe used for use in closed (process or supply) or vented (drain, waste or vent) piping systems. One pipe to be installed either concentrically or eccentrically within the firestop system. The annular space shall be min 1/4 in. (6 mm) to max 3-1/2 in. (89 mm). Pipe couplings to be located min 12 in. (305 mm) from floor or wall surfaces. Pipe to be rigidly supported on both sides of floor or wall assembly.

4. **Firestop System** — The firestop system shall consist of the following:

A. **Packing Material** — Min 4.0 pcf (64 kg/m<sup>3</sup>) mineral wool batt insulation installed in through opening as a permanent form. Pieces of batt cut to min width of 3-1/2 in. (89 mm) and installed edge-first into opening such that batt sections are tightly-compressed in thickness and such that the compressed batt sections are recessed from top surface of floor or from both surfaces of wall as required to accommodate the required thickness of fill material.

B. **Fill, Void or Cavity Material\* — Sealant** — Min 3/4 in. (19 mm) thickness of fill material applied within the annulus, flush with top surface of floor or with both surfaces of wall.

**HILTI CONSTRUCTION CHEMICALS, DIV OF HILTI INC** — FS-One Sealant or FS-ONE MAX Intumescent Sealant

**\* Indicates such products shall bear the UL or cUL Certification Mark for jurisdictions employing the UL or cUL Certification (such as Canada), respectively.**

Last Updated on 2015-01-27

---

[Questions?](#)

[Print this page](#)

[Terms of Use](#)

[Page Top](#)

© 2015 UL LLC

When the UL Leaf Mark is on the product, or when the word "Environment" is included in the UL Mark, please search the [UL Environment database](#) for additional information regarding this product's certification.

The appearance of a company's name or product in this database does not in itself assure that products so identified have been manufactured under UL's Follow-Up Service. Only those products bearing the UL Mark should be considered to be Certified and covered under UL's Follow-Up Service. Always look for the Mark on the product.

UL permits the reproduction of the material contained in the Online Certification Directory subject to the following conditions: 1. The Guide Information, Assemblies, Constructions, Designs, Systems, and/or Certifications (files) must be presented in their entirety and in a non-misleading manner, without any manipulation of the data (or drawings). 2. The statement "Reprinted from the Online Certifications Directory with permission from UL" must appear adjacent to the extracted material. In addition, the reprinted material must include a copyright notice in the following format: "© 2015 UL LLC".



**System No. C-AJ-2141**  
**XHEZ.C-AJ-2141**  
**Through-penetration Firestop Systems**

[Page Bottom](#)

---

**Design/System/Construction/Assembly Usage Disclaimer**

- Authorities Having Jurisdiction should be consulted in all cases as to the particular requirements covering the installation and use of UL Certified products, equipment, system, devices, and materials.
  - Authorities Having Jurisdiction should be consulted before construction.
  - Fire resistance assemblies and products are developed by the design submitter and have been investigated by UL for compliance with applicable requirements. The published information cannot always address every construction nuance encountered in the field.
  - When field issues arise, it is recommended the first contact for assistance be the technical service staff provided by the product manufacturer noted for the design. Users of fire resistance assemblies are advised to consult the general Guide Information for each product category and each group of assemblies. The Guide Information includes specifics concerning alternate materials and alternate methods of construction.
  - Only products which bear UL's Mark are considered Certified.
- 

**XHEZ - Through-penetration Firestop Systems**

[See General Information for Through-penetration Firestop Systems](#)

**System No. C-AJ-2141**

January 09, 2015

**F Rating — 3 Hr**

**T Rating — 2 Hr**

**L Rating At Ambient — Less Than 1 CFM/Sq Ft**

**L Rating At 400 F — 4 CFM/Sq ft**

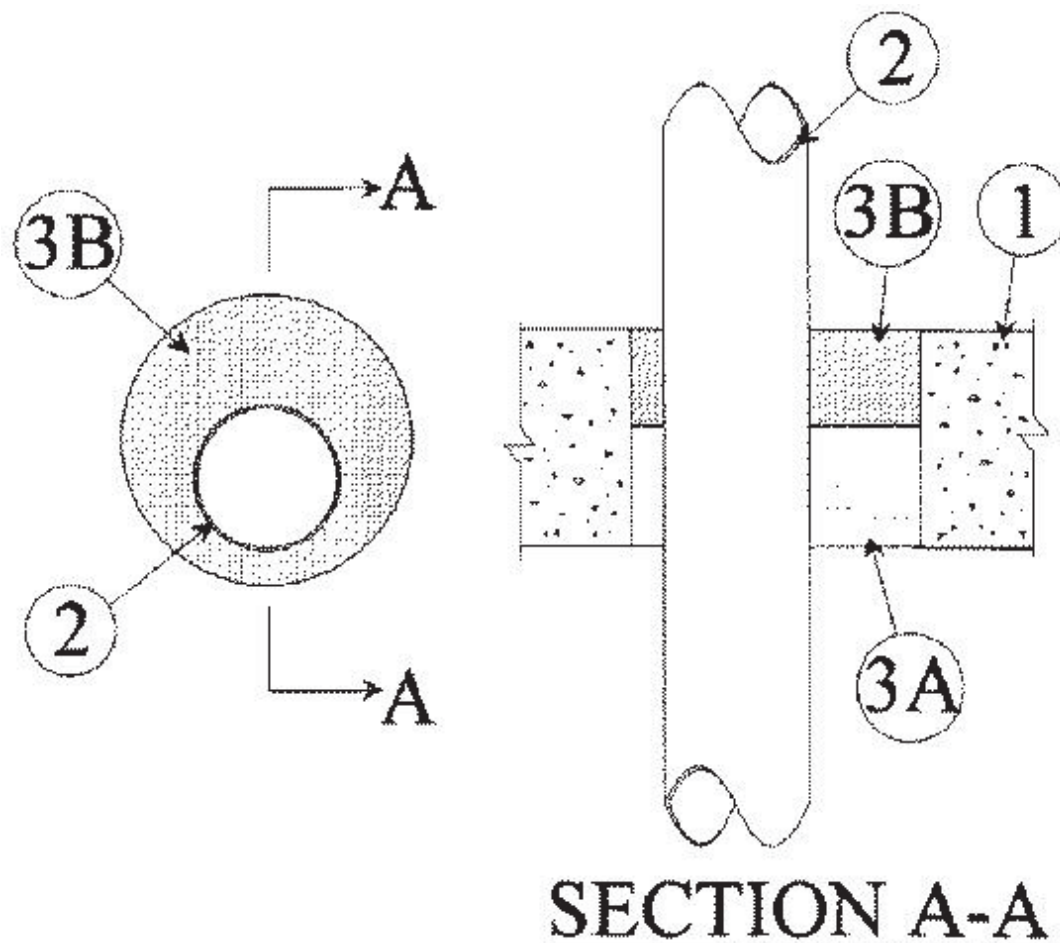

## SECTION A-A

1. **Floor or Wall Assembly** — Min 4-1/2 in. (114 mm) thick reinforced lightweight or normal weight (100-150 pcf or 1600-2400 kg/m<sup>3</sup>) concrete. Wall may also be constructed of any UL Classified Concrete Blocks\*. Max diam of opening is 6 in. (152 mm).

See **Concrete Blocks\*** (CAZT) category in the Fire Resistance Directory for names of manufacturers.

2. **Through Penetrants** — One nonmetallic pipe or conduit to be installed either concentrically or eccentrically within the firestop system. The annular space between the pipe or conduit and the periphery of the opening shall be min 1/2 in. (13 mm) to max 2 in. (51 mm). The pipe or conduit to be rigidly supported on both sides of floor or wall. The following types and sizes of pipes or conduits may be used:

A. **Polyvinyl Chloride (PVC) Pipe** — Nom 3 in. (76 mm) diam (or smaller) Schedule 40 PVC pipe for use in closed (process or supply) piping systems.

B. **Chlorinated Polyvinyl Chloride (CPVC) Pipe** — Nom 3 in. (76 mm) diam (or smaller) SDR 17 CPVC pipe for use in closed (process or supply) piping systems.

3. **Firestop System** — The firestop system shall consist of the following:

A. **Forming Material\*** — Min 2-1/2 in. (64 mm) thickness of forming material foamed into opening as a permanent form. Forming material to be recessed from top surface of floor or from both surfaces of wall as required to accommodate the required thickness of fill material.

**HILTI CONSTRUCTION CHEMICALS, DIV OF HILTI INC** — CF812 or CF-AS CJP Foam Sealant

B. **Fill, Void or Cavity Material\* — Sealant** — Min 2 in. (51 mm) thickness of fill material applied with annulus flush with top surface of floor or within both surfaces of wall.

**HILTI CONSTRUCTION CHEMICALS, DIV OF HILTI INC** — FS-ONE Sealant or FS-ONE MAX Intumescent Sealant

\* Indicates such products shall bear the UL or cUL Certification Mark for jurisdictions employing the UL or cUL Certification (such as Canada), respectively.

Last Updated on 2015-01-09

[Questions?](#)

[Print this page](#)

[Terms of Use](#)

[Page Top](#)

When the UL Leaf Mark is on the product, or when the word "Environment" is included in the UL Mark, please search the [UL Environment database](#) for additional information regarding this product's certification.

The appearance of a company's name or product in this database does not in itself assure that products so identified have been manufactured under UL's Follow-Up Service. Only those products bearing the UL Mark should be considered to be Certified and covered under UL's Follow-Up Service. Always look for the Mark on the product.

UL permits the reproduction of the material contained in the Online Certification Directory subject to the following conditions: 1. The Guide Information, Assemblies, Constructions, Designs, Systems, and/or Certifications (files) must be presented in their entirety and in a non-misleading manner, without any manipulation of the data (or drawings). 2. The statement "Reprinted from the Online Certifications Directory with permission from UL" must appear adjacent to the extracted material. In addition, the reprinted material must include a copyright notice in the following format: "© 2015 UL LLC".





## **System No. C-AJ-2217 XHEZ.C-AJ-2217 Through-penetration Firestop Systems**

[Page Bottom](#)

---

### **Design/System/Construction/Assembly Usage Disclaimer**

- Authorities Having Jurisdiction should be consulted in all cases as to the particular requirements covering the installation and use of UL Certified products, equipment, system, devices, and materials.
  - Authorities Having Jurisdiction should be consulted before construction.
  - Fire resistance assemblies and products are developed by the design submitter and have been investigated by UL for compliance with applicable requirements. The published information cannot always address every construction nuance encountered in the field.
  - When field issues arise, it is recommended the first contact for assistance be the technical service staff provided by the product manufacturer noted for the design. Users of fire resistance assemblies are advised to consult the general Guide Information for each product category and each group of assemblies. The Guide Information includes specifics concerning alternate materials and alternate methods of construction.
  - Only products which bear UL's Mark are considered Certified.
- 

### **XHEZ - Through-penetration Firestop Systems**

[See General Information for Through-penetration Firestop Systems](#)

### **System No. C-AJ-2217**

January 09, 2015

**F Rating — 2 Hr**

**T Rating — 0 Hr**

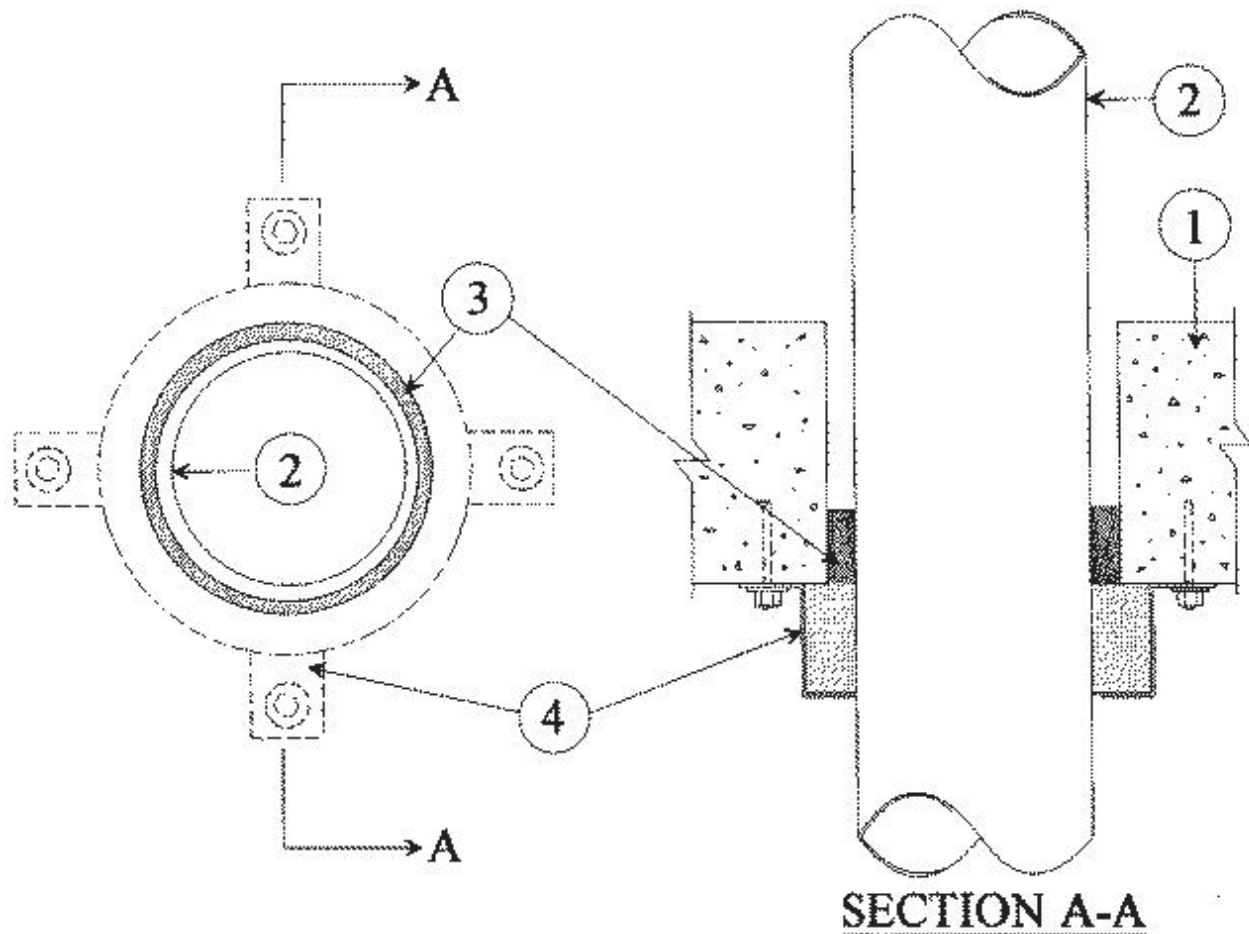

1. **Floor or Wall Assembly** — Min. 4-1/2 in. (114 mm) thick reinforced lightweight or normal weight (100-150 pcf or 1600-2400 kg/m<sup>3</sup>) concrete. Wall may also be constructed of any UL Classified **Concrete Blocks**. Max diam of opening is 7 in. (178 mm).

See **Concrete Blocks** (CAZT) category in the Fire Resistance Directory for names of manufacturers.

2. **Through Penetrants** — One nonmetallic pipe to be installed within the firestop system. The annular space shall be min 0 in. to max 3/8 in. (9.5 mm). Pipe to be rigidly supported on both sides of floor or wall assembly. The following types and sizes of nonmetallic pipes may be used:

A. **Polyvinylidene Fluoride (PVDF) Pipe** — Nom 6 in. (152 mm) diam (or smaller) SDR 32.5 PVDF pipe for use in closed (process or supply) or vented (drain, waste or vent) piping systems.

B. **Polypropylene (PP) Pipe** — Nom 4 in. (102 mm) diameter (or smaller) schedule 40 PP for use in closed (process or supply) or vented (drain, waste or vent) piping systems.

3. **Fill, Void or Cavity Material\*** — **Sealant** — Min 1 in. (25 mm) thickness of fill material applied within the annulus, flush with bottom surface of floor or with both surfaces of wall.

**HILTI CONSTRUCTION CHEMICALS, DIV OF HILTI INC** — FS-ONE Sealant or FS-ONE MAX Intumescent Sealant

4. **Firestop Device** — Firestop collar shall be installed in accordance with the accompanying installation instructions. Collar to be installed and latched around the pipe and secured to underside of floor on both sides of wall using the anchor hooks provided with the collar. (Minimum two anchor hooks for 1-1/2 and 2 in. diam pipes, three anchor hooks for 3 and 4 in. (102 mm) diam pipes, six anchor hooks for 6 in. (152 mm) diam pipes.). The anchor hooks are to be secured with min 1/4 in. (6 mm) diam by min 1-1/4 in. (32 mm) long steel expansion bolts or min 0.145 in. (3.7 mm) diam by 1-1/4 in. (32 mm) long powder actuated fasteners utilizing a 1-7/16 in. (36.5 mm) diam by 1/16 in. (1.6 mm) thick steel washer. As alternates to the anchors specified above, Hilti 1/4 in. (6 mm) diam by 1-1/4 in. (32 mm) long KWIK-CON II+ concrete screw anchor, Hilti 1/4 in. (6 mm) diam by 1-3/4 in. (44 mm) long KWIK-BOLT 3 steel expansion anchor or Hilti X-DNI 27 P8 S15 powder actuated floor pin with integral nom 9/16 in. (14 mm) diam washer may be used.

**HILTI CONSTRUCTION CHEMICALS, DIV OF HILTI INC** — CP 643 50/1.5"N, CP 643 63/2"N, CP 643 90/3"N, CP 643 110/4"N or CP643 160/6"N. Firestop Collar.

\* Indicates such products shall bear the UL or cUL Certification Mark for jurisdictions employing the UL or cUL Certification (such as Canada), respectively.

---

[Questions?](#)[Print this page](#)[Terms of Use](#)[Page Top](#)

© 2015 UL LLC

When the UL Leaf Mark is on the product, or when the word "Environment" is included in the UL Mark, please search the [UL Environment database](#) for additional information regarding this product's certification.

The appearance of a company's name or product in this database does not in itself assure that products so identified have been manufactured under UL's Follow-Up Service. Only those products bearing the UL Mark should be considered to be Certified and covered under UL's Follow-Up Service. Always look for the Mark on the product.

UL permits the reproduction of the material contained in the Online Certification Directory subject to the following conditions: 1. The Guide Information, Assemblies, Constructions, Designs, Systems, and/or Certifications (files) must be presented in their entirety and in a non-misleading manner, without any manipulation of the data (or drawings). 2. The statement "Reprinted from the Online Certifications Directory with permission from UL" must appear adjacent to the extracted material. In addition, the reprinted material must include a copyright notice in the following format: "© 2015 UL LLC".



## System No. C-AJ-5091 XHEZ.C-AJ-5091 Through-penetration Firestop Systems

[Page Bottom](#)

### Design/System/Construction/Assembly Usage Disclaimer

- Authorities Having Jurisdiction should be consulted in all cases as to the particular requirements covering the installation and use of UL Certified products, equipment, system, devices, and materials.
- Authorities Having Jurisdiction should be consulted before construction.
- Fire resistance assemblies and products are developed by the design submitter and have been investigated by UL for compliance with applicable requirements. The published information cannot always address every construction nuance encountered in the field.
- When field issues arise, it is recommended the first contact for assistance be the technical service staff provided by the product manufacturer noted for the design. Users of fire resistance assemblies are advised to consult the general Guide Information for each product category and each group of assemblies. The Guide Information includes specifics concerning alternate materials and alternate methods of construction.
- Only products which bear UL's Mark are considered Certified.

### XHEZ - Through-penetration Firestop Systems

### XHEZ7 - Through-penetration Firestop Systems Certified for Canada

[See General Information for Through-penetration Firestop Systems](#)

[See General Information for Through-penetration Firestop Systems Certified for Canada](#)

### System No. C-AJ-5091

January 13, 2015

ANSI/UL1479 (ASTM E814)	CAN/ULC S115
F Rating — 2 Hr	F Rating — 2 Hr
T Ratings — 0 and 1 Hr (See Items 2 and 4)	FT Ratings — 0 and 1 Hr (See Items 2 and 4)
L Rating At Ambient — 4 CFM/sq ft	FH Rating — 2 Hr
L Rating At 400 F — Less Than 1 CFM/sq ft	FTH Ratings — 0 and 1 Hr (See Items 2 and 4)
	L Rating At Ambient —4 CFM/sq ft
	L Rating At 400 F —Less Than 1 CFM/sq ft

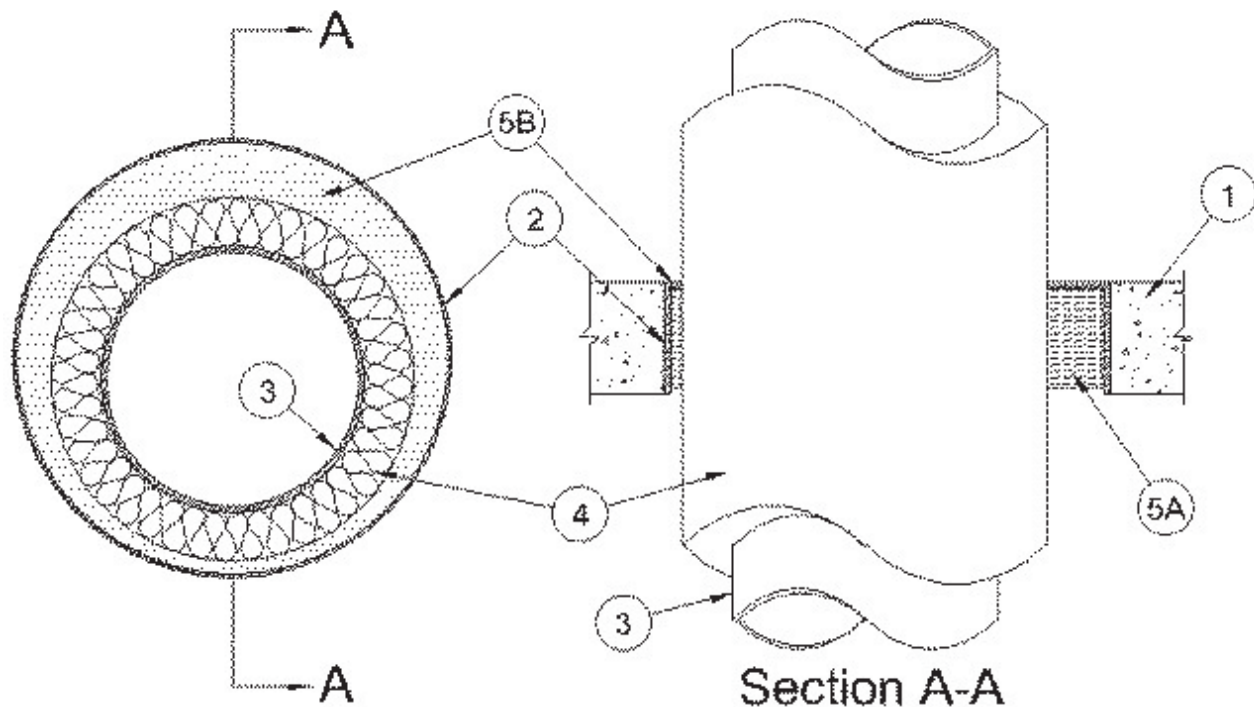

**1. Floor or Wall Assembly** — Min 4-1/2 in. (114 mm) thick reinforced lightweight or normal weight (100-150 pcf or 1600-2400 kg/m<sup>3</sup>) concrete. Wall may also be constructed of any UL Classified **Concrete Blocks\***. Max diam of opening is 29 in. (737 mm).

See **Concrete Blocks** (CAZT) category in the Fire Resistance directory for names of manufacturers.

**2. Metallic Sleeve** — (Optional) — Nom 30 in. (762 mm) diam (or smaller) Schedule 10 (or heavier) steel pipe sleeve cast or grouted into floor or wall assembly, flush with floor or wall surfaces or extending a max of 3 in. (76 mm) above floor or beyond both surfaces of wall. If the steel sleeve extends beyond the top surface of the floor or both surfaces of the wall, the T Rating of the firestop system is 0 hr.

**2A. Sheet Metal Sleeve** — (Optional) - Max 6 in. (152 mm) diam, min 26 ga galv steel provided with a 26 ga galv steel square flange spot welded to the sleeve at approximately mid- height, or flush with bottom of sleeve in floors, and sized to be a min of 2 in. (51 mm) larger than the sleeve diam. The sleeve is to be cast in place flush with bottom surface of floor and may extend a max of 1 in. (25 mm) above the top surface of the floor.

**2B. Sheet Metal Sleeve** — (Optional) - Max 12 in. (305 mm) diam, min 24 ga galv steel provided with a 24 ga galv steel square flange spot welded to the sleeve at approximately mid- height, or flush with bottom of sleeve in floors, and sized to be a min of 2 in. (51 mm) larger than the sleeve diam. The sleeve is to be cast in place flush with bottom surface of floor and may extend a max of 1 in. (25 mm) above the top surface of the floor.

**3. Through Penetrants** — One metallic pipe or tubing to be installed either concentrically or eccentrically within the firestop system. Pipe or tubing to be rigidly supported on both sides of floor or wall assembly. The following types and sizes of metallic pipes or tubing may be used:

- A. **Steel Pipe** — Nom 12 in. (305 mm) diam (or smaller) Schedule 10 (or heavier) steel pipe.
- B. **Iron Pipe** — Nom 12 in. (305 mm) diam (or smaller) cast or ductile iron pipe.
- C. **Copper Pipe** — Nom 6 in. (152 mm) diam (or smaller) Regular (or heavier) copper pipe.
- D. **Copper Tubing** — Nom 6 in. (152 mm) diam (or smaller) Type L (or heavier) copper tubing.

**4. Pipe Covering** — Min 1/2 in. (13 mm) to max 2 in. (51 mm) thick hollow cylindrical heavy density (min 3.5 pcf or 56 kg/m<sup>3</sup>) glass fiber units jacketed on the outside with an all-service jacket. Longitudinal joints sealed with metal fasteners or factory-applied, self-sealing lap tape. Transverse joints secured with metal fasteners or with butt tape supplied with the product. The annular space between the insulated pipe and the edge of the periphery of the opening shall be min 1/2 in. (13 mm) to max 12 in. (305 mm). **When thickness of pipe covering is less than 2 in. (51 mm), the T Rating for the firestop system is 0 hr.**

See **Pipe Equipment Covering — Materials** — (BRGU) category in the Building Materials Directory for names of manufacturers. Any pipe covering material meeting the above specifications and bearing the UL Classification Marking with a Flame Spread Index of 25 or less and a Smoke Developed Index of 50 or less may be used.

**4A. Pipe Covering** — (Not Shown) — As an alternate to Item 4, max 2 in. (51 mm) thick cylindrical calcium silicate (min 14 pcf or 224 kg/m<sup>3</sup>) units sized to the outside diam of the pipe or tube may be used. Pipe insulation secured with stainless steel bands or min 18 AWG stainless steel wire spaced max 12 in. (305 mm) OC. The annular space shall be min 1/2 in. (13 mm) to max 12 in. (305 mm).

**5. Firestop System** — The firestop system shall consist of the following:

A. **Packing Material** — Min 4 in. (102 mm) thickness of min 4 pcf (64 kg/m<sup>3</sup>) mineral wool batt insulation firmly packed into opening as a permanent form. Packing material to be recessed from top surface of floor or from both surfaces of wall as required to accommodate the required thickness of fill material.

B. **Fill, Void or Cavity Material\* — Sealant** — Min 1/2 in. (13 mm) thickness of fill material applied within the annulus, flush with top surface of floor or with both surfaces of wall.

**HILTI CONSTRUCTION CHEMICALS, DIV OF HILTI INC** — FS-One Sealant or FS-ONE MAX Intumescent Sealant

**\* Indicates such products shall bear the UL or cUL Certification Mark for jurisdictions employing the UL or cUL Certification (such as Canada), respectively.**

Last Updated on 2015-01-13

---

[Questions?](#)

[Print this page](#)

[Terms of Use](#)

[Page Top](#)

© 2015 UL LLC

When the UL Leaf Mark is on the product, or when the word "Environment" is included in the UL Mark, please search the [UL Environment database](#) for additional information regarding this product's certification.

The appearance of a company's name or product in this database does not in itself assure that products so identified have been manufactured under UL's Follow-Up Service. Only those products bearing the UL Mark should be considered to be Certified and covered under UL's Follow-Up Service. Always look for the Mark on the product.

UL permits the reproduction of the material contained in the Online Certification Directory subject to the following conditions: 1. The Guide Information, Assemblies, Constructions, Designs, Systems, and/or Certifications (files) must be presented in their entirety and in a non-misleading manner, without any manipulation of the data (or drawings). 2. The statement "Reprinted from the Online Certifications Directory with permission from UL" must appear adjacent to the extracted material. In addition, the reprinted material must include a copyright notice in the following format: "© 2015 UL LLC".



## System No. C-AJ-8041 XHEZ.C-AJ-8041 Through-penetration Firestop Systems

[Page Bottom](#)

### Design/System/Construction/Assembly Usage Disclaimer

- Authorities Having Jurisdiction should be consulted in all cases as to the particular requirements covering the installation and use of UL Certified products, equipment, system, devices, and materials.
- Authorities Having Jurisdiction should be consulted before construction.
- Fire resistance assemblies and products are developed by the design submitter and have been investigated by UL for compliance with applicable requirements. The published information cannot always address every construction nuance encountered in the field.
- When field issues arise, it is recommended the first contact for assistance be the technical service staff provided by the product manufacturer noted for the design. Users of fire resistance assemblies are advised to consult the general Guide Information for each product category and each group of assemblies. The Guide Information includes specifics concerning alternate materials and alternate methods of construction.
- Only products which bear UL's Mark are considered Certified.

### XHEZ - Through-penetration Firestop Systems

### XHEZ7 - Through-penetration Firestop Systems Certified for Canada

[See General Information for Through-penetration Firestop Systems](#)

[See General Information for Through-penetration Firestop Systems Certified for Canada](#)

### System No. C-AJ-8041

January 15, 2015

ANSI/UL1479 (ASTM E814)	CAN/ULC S115
F Rating — 3 Hr	F Rating — 3 Hr
T Ratings — 0 and 1 Hr (See Item 3)	FT Ratings — 0 and 1 Hr (See Item 3)
L Rating At Ambient — 10 CFM/sq ft	FH Rating — 3 Hr
L Rating At 400 F — 6 CFM/sq ft	FTH Ratings — 0 and 1 Hr (See Item 3)
	L Rating At Ambient — 10 CFM/sq ft
	L Rating At 400 F — 6 CFM/sq ft

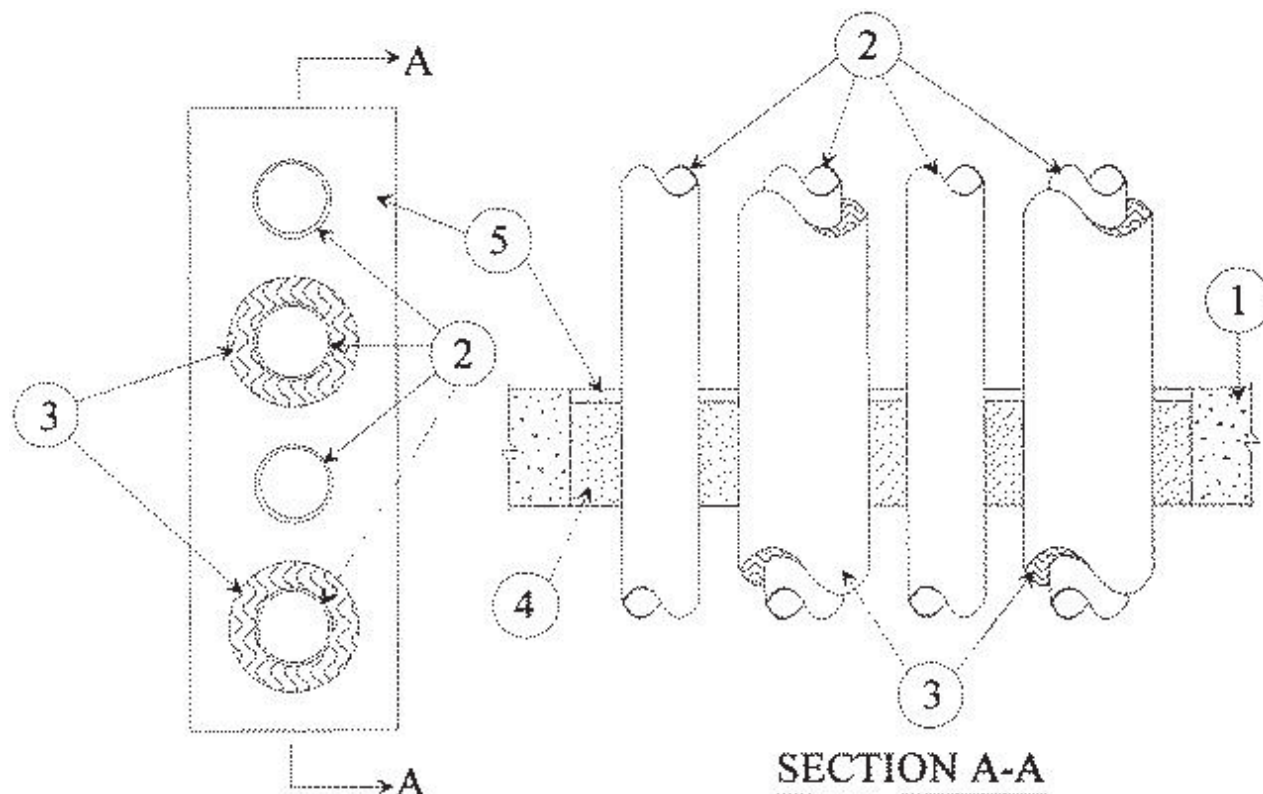

**1. Floor or Wall Assembly** — Min 4-1/2 in. (114 mm) thick reinforced lightweight or normal weight (100-150 pcf or 1600-2400 kg/m<sup>3</sup>) concrete floor or min 5 in. (127 mm) thick reinforced lightweight or normal weight (100-150 pcf or 1600-2400 kg/m<sup>3</sup>) concrete wall. Wall may also be constructed of any UL Classified **Concrete Blocks\***. Max area of opening is 192 sq in. (1239 cm<sup>2</sup>) with max dimension of 24 in. 9610 mm).

See **Concrete Blocks** (CAZT) category in the Fire Resistance Directory for names of manufacturers.

**2. Through-Penetrants** — A max of 4 pipes, conduits or tubing to be installed within the opening. The space between pipes, conduits or tubing shall be 1-1/2 in. (38 mm). The space between pipes, conduits or tubing and periphery of opening shall be min 1-5/8 in. (41 mm) to max 2-1/2 in. (64 mm). Pipe, conduit or tubing to be rigidly supported on both sides of floor or wall assembly. The following types and sizes of metallic pipes, conduits or tubing may be used:

- A. **Steel Pipe** — Nom 3 in. (76 mm) diam (or smaller) Schedule 10 (or heavier) steel pipe.
- B. **Copper Tubing** — Nom 3 in. (76 mm) diam (or smaller) Type L (or heavier) copper tubing.
- C. **Copper pipe** — Nom 3 in. (76 mm) diam (or smaller) regular (or heavier) copper pipe.
- D. **Conduit** — Nom 3 in. (76 mm) diam (or smaller) electrical metallic tubing or steel conduit.

**3. Pipe Covering\*** — (Optional) — Max 1 in. (25 mm) thick hollow cylindrical heavy density (min 3.5 pcf) glass fiber units jacketed on the outside with an all service jacket. Longitudinal joints sealed with metal fasteners or factory-applied self-sealing lap tape. Transverse joints secured with metal fasteners or with butt strip tape supplied with the product. A nom annular space of 1-1/2 in. (38 mm) is required within the firestop system. **The T, FT and FTH Rating is 1 hr when 1 in. thick pipe covering is used. The T, FT and FTH Rating is 0 hr when pipe covering is less than 1 in. or is omitted.**

See **Pipe and Equipment Covering — Materials** (BRGU) category in the Building Materials Directory for names of manufacturers. Any pipe covering material meeting the above specifications and bearing the UL Classification Marking with a Flame Spread Index of 25 or less and a Smoke Developed Index of 50 or less may be used.

**4. Packing Material** — Min 4 in. (102 mm) thickness of min 4.0 pcf (64 kg/m<sup>3</sup>) mineral wool batt insulation firmly packed into opening as a permanent form. Packing material to be recessed from top surface of floor or from both surfaces of wall as required to accommodate the required thickness of fill material.

**5. Fill, Void or Cavity Material\* — Sealant** — Min 1/2 in. (13 mm) thickness of fill material applied within the annulus, flush with top surface of floor or with both surfaces of wall.

**HILTI CONSTRUCTION CHEMICALS, DIV OF HILTI INC** — FS-One Sealant or FS-ONE MAX Intumescent Sealant.

\* Indicates such products shall bear the UL or cUL Certification Mark for jurisdictions employing the UL or cUL Certification (such as Canada), respectively.

Last Updated on 2015-01-15

[Questions?](#)

[Print this page](#)

[Terms of Use](#)

[Page Top](#)



When the UL Leaf Mark is on the product, or when the word "Environment" is included in the UL Mark, please search the [UL Environment database](#) for additional information regarding this product's certification.

The appearance of a company's name or product in this database does not in itself assure that products so identified have been manufactured under UL's Follow-Up Service. Only those products bearing the UL Mark should be considered to be Certified and covered under UL's Follow-Up Service. Always look for the Mark on the product.

UL permits the reproduction of the material contained in the Online Certification Directory subject to the following conditions: 1. The Guide Information, Assemblies, Constructions, Designs, Systems, and/or Certifications (files) must be presented in their entirety and in a non-misleading manner, without any manipulation of the data (or drawings). 2. The statement "Reprinted from the Online Certifications Directory with permission from UL" must appear adjacent to the extracted material. In addition, the reprinted material must include a copyright notice in the following format: "© 2015 UL LLC".



## System No. C-AJ-8056 XHEZ.C-AJ-8056 Through-penetration Firestop Systems

[Page Bottom](#)

### Design/System/Construction/Assembly Usage Disclaimer

- Authorities Having Jurisdiction should be consulted in all cases as to the particular requirements covering the installation and use of UL Certified products, equipment, system, devices, and materials.
- Authorities Having Jurisdiction should be consulted before construction.
- Fire resistance assemblies and products are developed by the design submitter and have been investigated by UL for compliance with applicable requirements. The published information cannot always address every construction nuance encountered in the field.
- When field issues arise, it is recommended the first contact for assistance be the technical service staff provided by the product manufacturer noted for the design. Users of fire resistance assemblies are advised to consult the general Guide Information for each product category and each group of assemblies. The Guide Information includes specifics concerning alternate materials and alternate methods of construction.
- Only products which bear UL's Mark are considered Certified.

### XHEZ - Through-penetration Firestop Systems

#### XHEZ7 - Through-penetration Firestop Systems Certified for Canada

[See General Information for Through-penetration Firestop Systems](#)

[See General Information for Through-penetration Firestop Systems Certified for Canada](#)

### System No. C-AJ-8056

January 15, 2015

ANSI/UL1479 (ASTM E814)	CAN/ULC S115
F Rating — 3 Hr	F Rating — 3 Hr
T Rating — 0 Hr	FT Rating — 0 Hr
L Rating At Ambient — 5 CFM/sq ft	FH Rating — 3 Hr
L Rating At 400 F — 2 CFM/sq ft	FTH Rating — 0 Hr
	L Rating At Ambient — 5 CFM/sq ft
	L Rating At 400 F — 2 CFM/sq ft

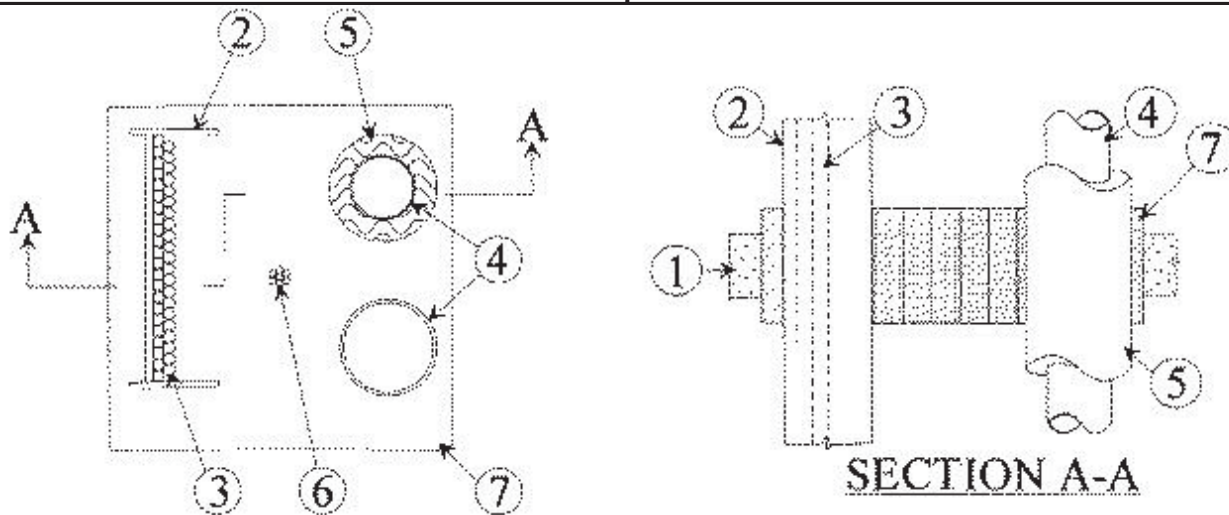

1. **Floor or Wall Assembly** — 4-1/2 in. (114 mm) thick reinforced lightweight or normal weight (100-150 pcf or 1600-2400 kg/m<sup>3</sup>) concrete. Wall may also be constructed of any UL Classified **Concrete Blocks\***. Max area of opening is

1296 in. sq (8361 cm<sup>2</sup>) with max dimension of 36 in. (914 mm).

See **Concrete Blocks** (CAZT) category in the Fire Resistance Directory for names of manufacturers.

2. **Cable Tray\*** — Max 18 in. (457 mm) wide by max 6 in. (152 mm) deep open-ladder or solid-back cable tray with channel-shaped side rails formed of 0.060 in. (1.52 mm) thick aluminum or steel and with 1-1/2 in. (38 mm) wide by 1 in. (25 mm) channel shape rungs spaced 9 in. (229 mm) OC or a 0.029 in. (0.74 mm) thick steel solid back, respectively. One cable tray to be installed in the opening. The max annular space between the cable tray and adjacent penetrants is 9 in. (229 mm) and between the cable tray and periphery of the opening shall be min 1-1/2 in. (38 mm) to max 4-1/2 in. (114 mm). Cable tray to be rigidly supported on both sides of floor or wall assembly.

3. **Cables** — Aggregate cross-sectional area of cables in cable tray to be max 30 percent of the cross-sectional area of the cable tray based on a max 3 in. (76 mm) cable loading depth within the cable tray. Any combination of the following types and sizes of copper conductor or fiber optic cables may be used:

- A. 7/C No. 12 AWG with polyvinyl chloride (PVC) insulation and PVC jacket.
- B. 300 pair - No. 24 AWG cable with PVC insulation and jacket.
- C. 1/C, 350 kcmil with cross-linked polyethylene (XLPE) insulation and jacket.
- D. 1/C, 500 kcmil with thermo plastic insulation and polyvinyl chloride (PVC) jacket.
- E. Twenty four fiber optic cable with PVC sub unit and jacket.

4. **Through-Penetrants** — One or more pipe, conduit or tube to be installed within the opening. The total number of through-penetrants is dependent on the size of the opening and types and sizes of the penetrants. Any combination of the penetrants described below may be used provided that the following parameters relative to the annular spaces and the spacings between the pipes are maintained. The space between pipes, conduits or tubing and between the periphery of the opening and the pipes or conduits shall be min 1 in. (25 mm) to max 4-1/2 in. (114 mm). Pipe, conduit or tube to be rigidly supported on both sides of floor or wall assembly. The following types and sizes of metallic pipes, conduits or tubing may be used:

- A. Nom 6 in. (152 mm) diam (or smaller) rigid galv steel conduit.
- B. Nom 4 in. (102 mm) diam (or smaller) steel electrical metallic tubing.
- C. Nom 4 in. (102 mm) diam (or smaller) Regular (or heavier) copper pipe.
- D. Nom 4 in. (102 mm) diam (or smaller) Type L (or heavier) copper tube.
- E. Nom 6 in. (152 mm) diam (or smaller) Schedule 10 (or heavier) steel pipe.
- F. Nom 6 in. (152 mm) diam (or smaller) cast or ductile iron pipe.

5. **Pipe Covering** — Nom 1-1/2 in. (38 mm) thick hollow cylindrical heavy density (min 3.5 pcf) glass fiber units jacketed on the outside with an all service jacket. Longitudinal joints sealed with metal fasteners or factory applied self-sealing lap tape. Transverse joints secured with metal fasteners or with butt tape supplied with the product.

See **Pipe and Equipment Covering and Materials** (BRGU) category in the Building Materials Directory for names of manufacturers. Any pipe covering material meeting the above specifications and bearing the UL Classification Marking with a Flame Spread Index of 25 or less and a Smoke Developed Index of 50 may be used.

6. **Cables** — Max 2 in. (51 mm) diam tight bundle of cables centered in opening and rigidly supported on both surfaces of floor and wall. Any combination of the following types and sizes of cables may be used:

- A. 7/C No. 12 AWG with polyvinyl chloride (PVC) insulation and PVC jacket.
- B. 25 pair - No. 24 AWG cable with PVC insulation and jacket.
- C. 2/C No. 10 AWG with PVC insulation and jacket.
- D. 3/C No. 8 AWG aluminum clad cable with cross-linked polyethylene (XLPE) insulation and PVC jacket.
- E. Type RC - 62 A/U coaxial cable with air core and PVC jacket.
- F. 24 fiber optic cable with PVC sub unit and outer jacket.

7. **Firestop System** — The firestop system shall consist of the following:

A. **Fill, Void or Cavity Material\*** — Fire blocks installed with long dimension passed through the opening and centered within the thickness of the floor or wall. Blocks to be firmly packed and completely fill the entire area and thickness of opening. Either one or a combination of the block types specified below may be used.

**HILTI CONSTRUCTION CHEMICALS, DIV OF HILTI INC** — FS 657 -Fire Block or CFS-BL Firestop Block

B. **Fill, Void or Cavity Material\*** — (Not Shown) Fill material to be forced into interstices of cables and between cables and cable trays to max extent possible on both surfaces of the penetration.

**HILTI CONSTRUCTION CHEMICALS, DIV OF HILTI INC** — FS-One Sealant, FS-ONE MAX Intumescent Sealant, or CP618 Firestop Putty Stick (L Rating applies only when FS-One Sealant

is used.)

**C. Wire Mesh (Not Shown)** — When the annular space exceeds 4-1/2 in. (114 mm) to the periphery, a nom 2 in. sq (51 mm sq.) wire fencing shall be used to keep the fire blocks in place. The wire fencing is fabricated from min No. 16 SWG (0.060 in.) (1.52 mm) galv steel wire. The wire is cut to fit the contour of the penetrating item with a min 3 in. (76 mm) lap beyond the periphery of the opening. Wire fencing secured to top surface of floor and both surfaces of wall assembly by means of 1/4 in. (6 mm) diam by 1 in. (25 mm) long concrete anchors and 1/4 in. (6 mm) by 1-1/2 in. (38 mm) diam fender washers spaced max 8 in. (203 mm) OC.

**\* Indicates such products shall bear the UL or cUL Certification Mark for jurisdictions employing the UL or cUL Certification (such as Canada), respectively.**

Last Updated on 2015-01-15

[Questions?](#)

[Print this page](#)

[Terms of Use](#)

[Page Top](#)

© 2015 UL LLC

When the UL Leaf Mark is on the product, or when the word "Environment" is included in the UL Mark, please search the [UL Environment database](#) for additional information regarding this product's certification.

The appearance of a company's name or product in this database does not in itself assure that products so identified have been manufactured under UL's Follow-Up Service. Only those products bearing the UL Mark should be considered to be Certified and covered under UL's Follow-Up Service. Always look for the Mark on the product.

UL permits the reproduction of the material contained in the Online Certification Directory subject to the following conditions: 1. The Guide Information, Assemblies, Constructions, Designs, Systems, and/or Certifications (files) must be presented in their entirety and in a non-misleading manner, without any manipulation of the data (or drawings). 2. The statement "Reprinted from the Online Certifications Directory with permission from UL" must appear adjacent to the extracted material. In addition, the reprinted material must include a copyright notice in the following format: "© 2015 UL LLC".



## System No. C-BJ-4025 XHEZ.C-BJ-4025 Through-penetration Firestop Systems

[Page Bottom](#)

### Design/System/Construction/Assembly Usage Disclaimer

- Authorities Having Jurisdiction should be consulted in all cases as to the particular requirements covering the installation and use of UL Certified products, equipment, system, devices, and materials.
- Authorities Having Jurisdiction should be consulted before construction.
- Fire resistance assemblies and products are developed by the design submitter and have been investigated by UL for compliance with applicable requirements. The published information cannot always address every construction nuance encountered in the field.
- When field issues arise, it is recommended the first contact for assistance be the technical service staff provided by the product manufacturer noted for the design. Users of fire resistance assemblies are advised to consult the general Guide Information for each product category and each group of assemblies. The Guide Information includes specifics concerning alternate materials and alternate methods of construction.
- Only products which bear UL's Mark are considered Certified.

### XHEZ - Through-penetration Firestop Systems

### XHEZ7 - Through-penetration Firestop Systems Certified for Canada

[See General Information for Through-penetration Firestop Systems](#)

[See General Information for Through-penetration Firestop Systems Certified for Canada](#)

### System No. C-BJ-4025

January 16, 2015

ANSI/UL1479 (ASTM E814)	CAN/ULC S115
F Rating — 2 Hr	F Rating — 2 Hr
T Ratings - 0, 1 and 1-1/2 Hr (See Items 4 and 5C)	FT Ratings - 0, 1 and 1-1/2 Hr (See Items 4 and 5C)
	FH Rating — 2 Hr
	FTH Ratings - 0, 1 and 1-1/2 Hr (See Items 4 and 5C)

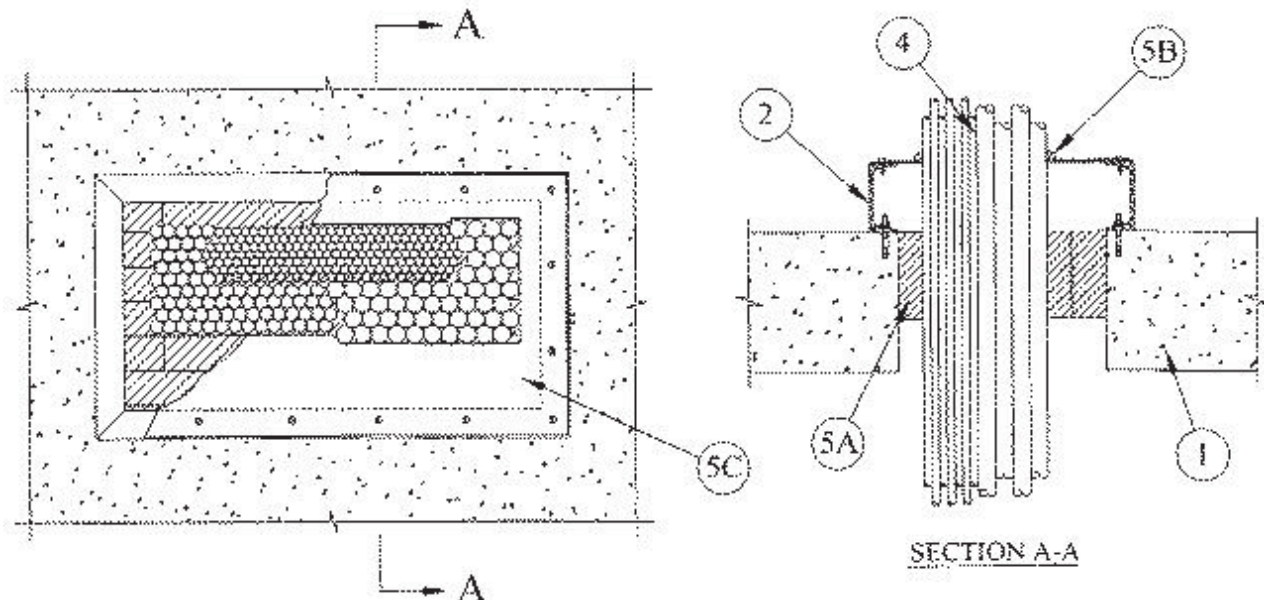

1. **Floor or Wall Assembly** — Min 8 in. (203 mm) thick reinforced lightweight or normal weight (100-150 pcf) concrete. Max area of opening is 288 sq in. (1858 cm<sup>2</sup>) with max dimension of 24 in. (610 mm).

2. **Sheathing** — Nom 1-1/2 in. (38 mm) by 4 in. (102 mm) by 3/16 in. (4.8 mm) thick steel channel shaped members secured to the concrete (Item 1) by means of 1/4 in. (6 mm) diam by 1-1/4 in. (32 mm) long concrete screw fasteners spaced 6 in. (152 mm) to 8 in. (203 mm) OC. The sheathing shall completely enclose the perimeter of the opening on top surface of floor assembly and one surface of wall assembly for asymmetrical systems and both surfaces of wall assembly for symmetrical systems.

3. **Cable Rack** — (Not Shown)—Max 20 in. (508 mm) wide cable rack, fabricated from min 1/4 in. (6 mm) thick by 1-1/2 in. (38 mm) wide steel bar side rails and 3/16 in. (4.8 mm) thick by 1 in. (25 mm) wide C-shaped rungs spaced 9 in. (229 mm) OC. Cable rack shall be welded or bolted to top surface of sheathing (Item 2).

4. **Cables** — Aggregate cross-sectional area of cables in opening to be max 34 percent of the cross-sectional area of the opening. The annular space between cables and the periphery of the opening to be min 1 in. (25 mm). Cables to be rigidly supported on both sides of floor or wall assembly. Any combination of the following types and sizes of cables may be used:

- A. Max 300 pair No. 24 AWG telephone cable with polyvinyl chloride (PVC) insulation and jacket.
- B. Max 750 kcmil power cable with cross-linked polyethylene (XLPE) insulation and polyvinyl chloride (PVC) jacket.
- C. Multiple fiber optic communication cable with polyvinyl chloride (PVC) jacket, having a max OD of 1/2 in. (13 mm).

**The T Rating of the firestop system is dependent upon the type of cable used within the firestop system as shown in the following table:**

Cable Identification	T, FT and FTH Ratings, Hr
A	1-1/2
B and C	1

5. **Firestop System** — The firestop system may be installed as an asymmetrical system in a floor and symmetrical or asymmetrical system in a wall assembly. The firestop system shall consist of the following items:

A. **Fill, Void or Cavity Materials\*—Fire Blocks** — Fire blocks installed with 5 in. (127 mm) dimension projecting through the opening, flush with the top surface of concrete or either wall surface. Blocks to be firmly packed and completely fill the entire length and width of the opening. Either one or a combination of the block types specified below may be used.

**HILTI CONSTRUCTION CHEMICALS, DIV OF HILTI INC** — FS 657 Fire Block or CFS-BL Firestop Block

B. **Fill, Void or Cavity Materials\*—Putty** — When cover plate is used, formed into pads 1/4 in. (6 mm) thick, installed around periphery of cable bundle, extending min 2 in. (51 mm) onto penetrant and overlapping cover plate by min 1/2 in. (13 mm).

**HILTI CONSTRUCTION CHEMICALS, DIV OF HILTI INC** — CP 618 Firestop Putty Stick

B1. **Fill, Void or Cavity Materials\*—Sealant (Optional) (Not Shown)** — When cover plate is used, min 1/2 in. (13 mm) thickness of fill material to be applied at cables/cover plate interface. Additional 3/8 in. (9.53 mm) bead of fill material applied at fill cover plate interface, overlapping cover plate.

**HILTI CONSTRUCTION CHEMICALS, DIV OF HILTI INC** — FS-ONE Sealant or FS-ONE MAX Intumescent Sealant.

C. **Steel Cover Plate (Optional)** — Min 0.020 in. (0.51 mm) thick (No. 22 MSG) steel plate shall be cut to fit contour of the cable bundle. Steel cover plate secured to the sheathing with 1/4-20 bolts or screws spaced max 12 in. (305 mm) OC. Annular space between the cables and the cover plate shall be min 0 in. (point contact) to max 1 in. (25 mm). Annular space between cables and sheathing shall be min 0 in. (point contact) to max 1 in. (25 mm). In order to achieve a T, FT and FTH Rating greater than 0 Hr, the annular spaces shall be treated as described in Items 5B and 5B1. When the cover plate is not used or annular spaces are not treated, the T, FT and FTH Ratings are 0 Hr.

**\* Indicates such products shall bear the UL or cUL Certification Mark for jurisdictions employing the UL or cUL Certification (such as Canada), respectively.**

Last Updated on 2015-01-16

[Questions?](#)

[Print this page](#)

[Terms of Use](#)

[Page Top](#)

[database](#) for additional information regarding this product's certification.

The appearance of a company's name or product in this database does not in itself assure that products so identified have been manufactured under UL's Follow-Up Service. Only those products bearing the UL Mark should be considered to be Certified and covered under UL's Follow-Up Service. Always look for the Mark on the product.

UL permits the reproduction of the material contained in the Online Certification Directory subject to the following conditions: 1. The Guide Information, Assemblies, Constructions, Designs, Systems, and/or Certifications (files) must be presented in their entirety and in a non-misleading manner, without any manipulation of the data (or drawings). 2. The statement "Reprinted from the Online Certifications Directory with permission from UL" must appear adjacent to the extracted material. In addition, the reprinted material must include a copyright notice in the following format: "© 2015 UL LLC".



## System No. C-BJ-4026 XHEZ.C-BJ-4026 Through-penetration Firestop Systems

[Page Bottom](#)

### Design/System/Construction/Assembly Usage Disclaimer

- Authorities Having Jurisdiction should be consulted in all cases as to the particular requirements covering the installation and use of UL Certified products, equipment, system, devices, and materials.
- Authorities Having Jurisdiction should be consulted before construction.
- Fire resistance assemblies and products are developed by the design submitter and have been investigated by UL for compliance with applicable requirements. The published information cannot always address every construction nuance encountered in the field.
- When field issues arise, it is recommended the first contact for assistance be the technical service staff provided by the product manufacturer noted for the design. Users of fire resistance assemblies are advised to consult the general Guide Information for each product category and each group of assemblies. The Guide Information includes specifics concerning alternate materials and alternate methods of construction.
- Only products which bear UL's Mark are considered Certified.

### XHEZ - Through-penetration Firestop Systems

### XHEZ7 - Through-penetration Firestop Systems Certified for Canada

[See General Information for Through-penetration Firestop Systems](#)

[See General Information for Through-penetration Firestop Systems Certified for Canada](#)

### System No. C-BJ-4026

January 16, 2015

ANSI/UL1479 (ASTM E814)	CAN/ULC S115
F Rating — 2 Hr	F Rating — 2 Hr
T Ratings - 0 and 1-1/2 Hr (See Item 5C)	FT Ratings - 0 and 1-1/2 Hr (See Item 5C)
	FH Rating — 2 Hr
	FTH Ratings - 0 and 1-1/2 Hr (See Item 5C)

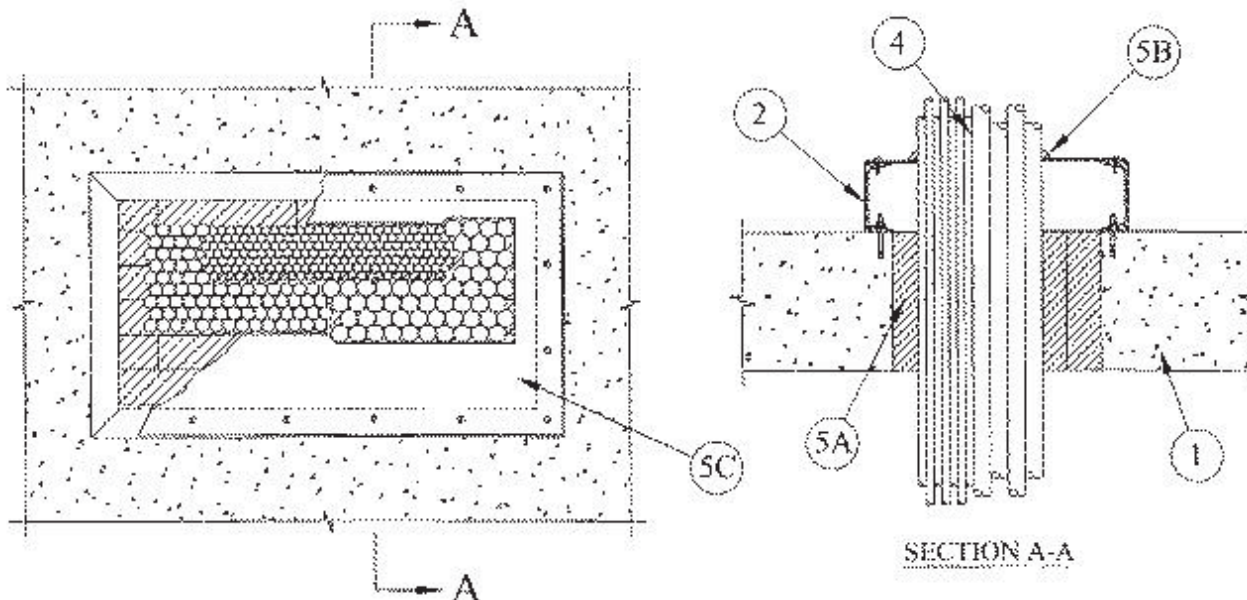

1. **Floor or Wall Assembly** — Min 8 in. (203 mm) thick reinforced lightweight or normal weight (100-150 pcf or 1600-2400 kg/m<sup>3</sup>) concrete. Max area of opening is 288 sq in. (1858 cm<sup>2</sup>) with max dimension of 24 in. (610 mm).



2. **Sheathing** — Nom 1-1/2 in. (38 mm) by 4 in. (102 mm) by 3/16 in. (4.8 mm) thick steel channel channel-shaped members secured to the concrete (Item 1) by means of 1/4 in. (6 mm) diam by 1-1/4 in. (32 mm) long concrete screw fasteners spaced 6 in. (152 mm) to 8 in. (203 mm) OC. The sheathing shall completely enclose the perimeter of the opening on the top surface of the floor assembly or on one surface of wall assembly for asymmetrical systems and on both surfaces of wall assembly for symmetrical systems.

3. **Cable Rack** — Max 20 in. (508 mm) wide cable rack, fabricated from min 1/4 in. (6 mm) thick by 1-1/2 in. (38 mm) wide steel bar side rails and 3/16 in. (4.8 mm) thick by 1 in. (25 mm) wide C-shaped steel rungs spaced 9 in. (229 mm) OC. Cable rack shall be welded or bolted to top surface of sheathing (Item 2).

4. **Cables** — Aggregate cross-sectional area of cables in opening to be max 34 percent of the cross-sectional area of the opening. The annular space between cables and the periphery of the opening to be min 1 in. (25 mm). Cables to be rigidly supported on both sides of floor or wall assembly. Any combination of the following types and sizes of cables may be used:

- A. Max 300 pair No. 24 AWG telephone cable with polyvinyl chloride (PVC) insulation and jacket.
- B. Max 750 kcmil power cable with cross-linked polyethylene (XLPE) insulation and polyvinyl chloride (PVC) jacket.
- C. Multiple fiber optic communication cable with polyvinyl chloride (PVC) jacket, having a max OD of 1/2 in. (13 mm).

5. **Firestop System** — The firestop system may be installed as an asymmetrical system in a floor and symmetrical or asymmetrical system in a wall assembly. The firestop system shall consist of the following items:

A. **Fill, Void or Cavity Materials\*—Fire Blocks** — Fire blocks installed with long dimension projecting through the opening flush with the top surface of concrete floor or either wall surface. Blocks to be firmly packed and completely fill the entire length and width of the opening. Either one or a combination of the block types specified below may be used.

**HILTI CONSTRUCTION CHEMICALS, DIV OF HILTI INC** — FS 657 Fire Block or CFS-BL Firestop Block

B. **Fill, Void or Cavity Materials\*—Putty** — When cover plate is used, formed into pads 1/4 in. (6 mm) thick, installed around periphery of cable bundle, extending min 2 in. (51 mm) onto penetrant and overlapping cover plate by min 1/2 in. (13 mm).

**HILTI CONSTRUCTION CHEMICALS, DIV OF HILTI INC** — CP 618 Firestop Putty Stick

B1. **Fill, Void or Cavity Materials\*—Sealant** — When cover plate is used, min 1/2 in. (13 mm) thickness of fill material to be applied at cables/cover plate interface. Additional 3/8 in. (9.53 mm) bead of fill material applied at fill cover plate interface, overlapping cover plate.

**HILTI CONSTRUCTION CHEMICALS, DIV OF HILTI INC** — FS-ONE Sealant or FS-ONE MAX Intumescent Sealant.

C. **Steel Cover Plate (Optional)** — Min 0.020 in. (0.51 mm) thick (No. 22 MSG) steel plate shall be cut to fit contour of the cable bundle. Steel cover plate secured to the sheathing with 1/4-20 bolts or screws spaced max 12 in. (305 mm) OC. As an alternate fastener, Southco® Medium Bail Style Quarter-turn steel stud/receptacle fasteners may be used. Annular space between the cables and the cover plate shall be min 0 in. (point contact) to max 1 in. (25 mm). Annular space between cables and sheathing shall be min 0 in. (point contact) to max 1 in. (25 mm). In order to achieve a T, FT And FTH Rating of 1-1/2 Hr, the annular spaces shall be treated as described in Items 5B and 5B1. When the cover plate is not used or annular spaces are not treated, the T, FT and FTH Ratings are 0 Hr.

**\* Indicates such products shall bear the UL or cUL Certification Mark for jurisdictions employing the UL or cUL Certification (such as Canada), respectively.**

Last Updated on 2015-01-16

[Questions?](#)

[Print this page](#)

[Terms of Use](#)

[Page Top](#)

© 2015 UL LLC

When the UL Leaf Mark is on the product, or when the word "Environment" is included in the UL Mark, please search the [UL Environment database](#) for additional information regarding this product's certification.

The appearance of a company's name or product in this database does not in itself assure that products so identified have been manufactured under UL's Follow-Up Service. Only those products bearing the UL Mark should be considered to be Certified and covered under UL's Follow-Up Service. Always look for the Mark on the product.

UL permits the reproduction of the material contained in the Online Certification Directory subject to the following conditions: 1. The Guide Information, Assemblies, Constructions, Designs, Systems, and/or Certifications (files) must be presented in their entirety and in a non-misleading manner, without any manipulation of the data (or drawings). 2. The statement "Reprinted from the Online Certifications Directory with permission from UL" must appear adjacent to the extracted material. In addition, the reprinted material must include a copyright notice in

the following format: "© 2015 UL LLC".



## System No. F-A-1014 XHEZ.F-A-1014 Through-penetration Firestop Systems

[Page Bottom](#)

### Design/System/Construction/Assembly Usage Disclaimer

- Authorities Having Jurisdiction should be consulted in all cases as to the particular requirements covering the installation and use of UL Certified products, equipment, system, devices, and materials.
- Authorities Having Jurisdiction should be consulted before construction.
- Fire resistance assemblies and products are developed by the design submitter and have been investigated by UL for compliance with applicable requirements. The published information cannot always address every construction nuance encountered in the field.
- When field issues arise, it is recommended the first contact for assistance be the technical service staff provided by the product manufacturer noted for the design. Users of fire resistance assemblies are advised to consult the general Guide Information for each product category and each group of assemblies. The Guide Information includes specifics concerning alternate materials and alternate methods of construction.
- Only products which bear UL's Mark are considered Certified.

### XHEZ - Through-penetration Firestop Systems

### XHEZ7 - Through-penetration Firestop Systems Certified for Canada

[See General Information for Through-penetration Firestop Systems](#)

[See General Information for Through-penetration Firestop Systems Certified for Canada](#)

## System No. F-A-1014

January 16, 2015

ANSI/UL1479 (ASTM E814)	CAN/ULC S115
F Rating — 2 Hr	F Rating — 2 Hr
T Rating — 0 Hr	FT Rating — 0 Hr
	FH Rating — 2 Hr
	FTH Rating — 0 Hr

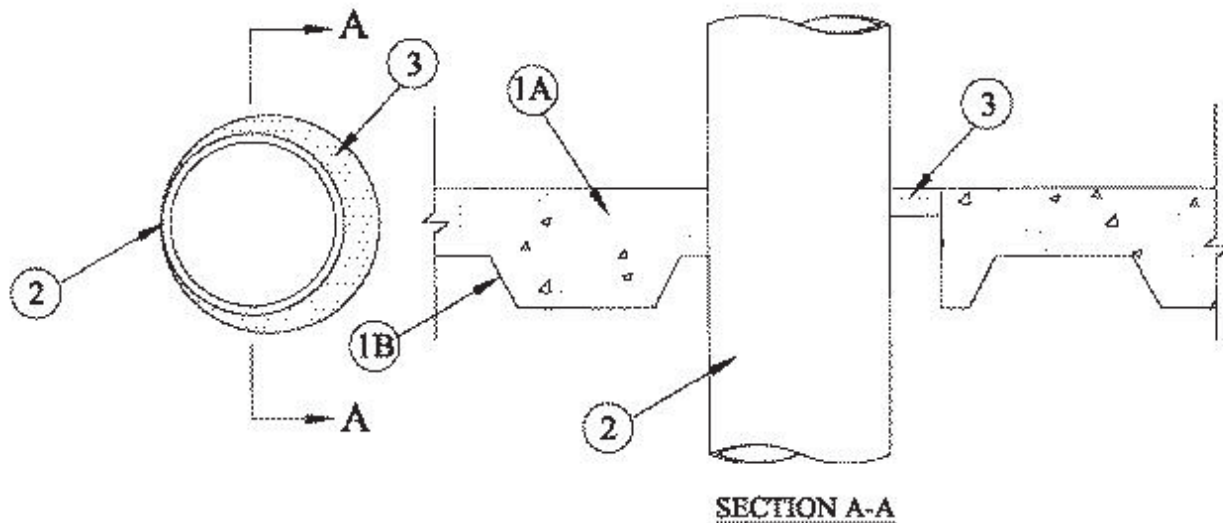

**1. Floor Assembly** — The fire rated unprotected concrete and steel floor assembly shall be constructed of the materials and in the manner specified in the individual D900 Series designs in the UL Fire Resistance Directory and as summarized below:

**A. Concrete** — Min 2-1/2 in. (64 mm) thick reinforced lightweight or normal weight (100-150 pcf or 1600-2400 kg/m<sup>3</sup>) concrete.

B. **Steel Floor and Form Units\*** — Composite or non-composite max 3 in. (76 mm) deep galv steel fluted units as specified in the individual Floor-Ceiling Design. Max diam of opening is 14-5/8 in. (371 mm).

2. **Through Penetrants** — One metallic tubing, pipe or conduit to be installed within the firestop system. Pipe, tubing or conduit to be rigidly supported on both sides of floor-ceiling assembly. The annular space between pipe, tubing or conduit and periphery of opening shall be min of 0 in. (point contact) to max 1-7/8 in. (48 mm). The following types and sizes of metallic pipes, tubing or conduit may be used:

A. **Steel Pipe** — Nom 12 in. (305 mm) diam (or smaller) Schedule 10 (or heavier) steel pipe.

B. **Conduit** — Nom 4 in. (102 mm) diam (or smaller) steel electrical metallic tubing or nom 6 in. (152 mm) diam (or smaller) steel conduit.

C. **Copper Tube** — Nom 6 in. (152 mm) diam (or smaller) Type L (or heavier) copper tube.

D. **Copper Pipe** — Nom 6 in. (152 mm) diam (or smaller) Regular (or heavier) copper pipe.

3. **Fill, Void or Cavity Materials\*-Sealant** — Min 1 in. (25 mm) thickness of sealant applied within annular space, flush with top surface of floor. At the point contact location, between pipe and concrete, a min 1/2 in. (13 mm) diam bead of fill material shall be applied at the concrete/pipe interface on the top surface of floor.

**HILTI CONSTRUCTION CHEMICALS, DIV OF HILTI INC** — FS-ONE Sealant or FS-ONE MAX Intumescent Sealant.

**\* Indicates such products shall bear the UL or cUL Certification Mark for jurisdictions employing the UL or cUL Certification (such as Canada), respectively.**

Last Updated on 2015-01-16

[Questions?](#)

[Print this page](#)

[Terms of Use](#)

[Page Top](#)

© 2015 UL LLC

When the UL Leaf Mark is on the product, or when the word "Environment" is included in the UL Mark, please search the [UL Environment database](#) for additional information regarding this product's certification.

The appearance of a company's name or product in this database does not in itself assure that products so identified have been manufactured under UL's Follow-Up Service. Only those products bearing the UL Mark should be considered to be Certified and covered under UL's Follow-Up Service. Always look for the Mark on the product.

UL permits the reproduction of the material contained in the Online Certification Directory subject to the following conditions: 1. The Guide Information, Assemblies, Constructions, Designs, Systems, and/or Certifications (files) must be presented in their entirety and in a non-misleading manner, without any manipulation of the data (or drawings). 2. The statement "Reprinted from the Online Certifications Directory with permission from UL" must appear adjacent to the extracted material. In addition, the reprinted material must include a copyright notice in the following format: "© 2015 UL LLC".



## System No. F-A-1028 XHEZ.F-A-1028 Through-penetration Firestop Systems

[Page Bottom](#)

### Design/System/Construction/Assembly Usage Disclaimer

- Authorities Having Jurisdiction should be consulted in all cases as to the particular requirements covering the installation and use of UL Certified products, equipment, system, devices, and materials.
- Authorities Having Jurisdiction should be consulted before construction.
- Fire resistance assemblies and products are developed by the design submitter and have been investigated by UL for compliance with applicable requirements. The published information cannot always address every construction nuance encountered in the field.
- When field issues arise, it is recommended the first contact for assistance be the technical service staff provided by the product manufacturer noted for the design. Users of fire resistance assemblies are advised to consult the general Guide Information for each product category and each group of assemblies. The Guide Information includes specifics concerning alternate materials and alternate methods of construction.
- Only products which bear UL's Mark are considered Certified.

### XHEZ - Through-penetration Firestop Systems

#### XHEZ7 - Through-penetration Firestop Systems Certified for Canada

[See General Information for Through-penetration Firestop Systems](#)

[See General Information for Through-penetration Firestop Systems Certified for Canada](#)

### System No. F-A-1028

January 15, 2015

ANSI/UL1479 (ASTM E814)	CAN/ULC S115
F Rating — 2 Hr	F Rating — 2 Hr
T Rating — 0 Hr	FT Rating — 0 Hr
	FH Rating — 2 Hr
	FTH Rating — 0 Hr

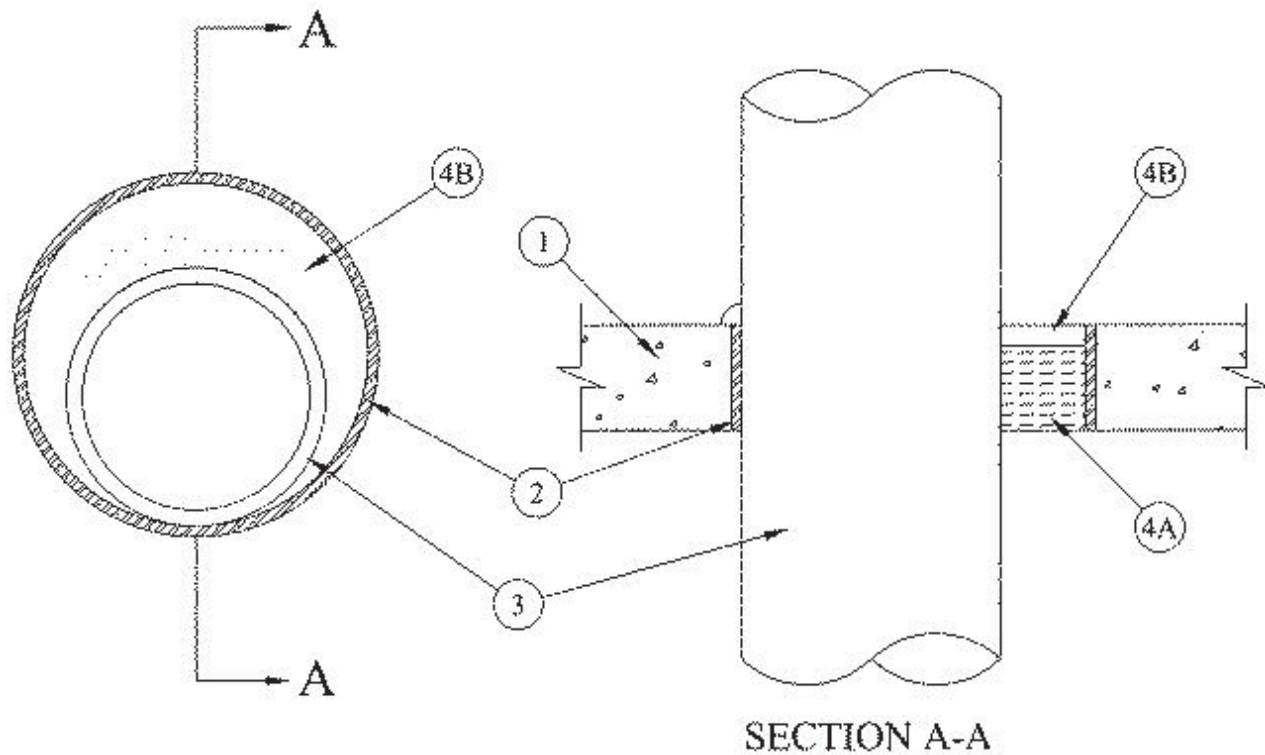

**1. Floor Assembly** — Min 2-1/2 in. (64 mm) thick reinforced lightweight or normal weight (100-150 pcf or 1600-2400 kg/m<sup>3</sup>) concrete. Max diameter of opening is 31-7/8 in. (810 mm).

**1A. Floor Assembly** — (Optional) - (Not Shown) -The fire rated unprotected concrete and steel floor assembly shall be constructed of the materials and in the manner specified in the individual D900 Series designs in the UL Fire Resistance Directory and as summarized below.

**A. Concrete** — Min 2-1/2 in. (64 mm) thick reinforced lightweight or normal weight (100-150 pcf or 1600-2400 kg/m<sup>3</sup>) concrete.

**B. Steel Floor and Form Units\*** — Composite or non-composite max 3 in. (76 mm) deep galv steel fluted units as specified in the individual Floor-Ceiling Design. Max diam of opening is 31-7/8 in. (810 mm).

**2. Steel Sleeve** — (Optional) - Nom 32 in. (813 mm) diam (or smaller) Schedule 40 steel pipe cast or grouted into floor assembly, flush with floor surfaces.

**2A. Sheet Metal Sleeve** — (Optional) - Max 6 in. (152 mm) diam, min 26 ga galv steel provided with a 26 ga galv steel square flange spot welded to the sleeve at approx mid-height, or flush with bottom of sleeve in floors, and sized to be a min of 2 in. (51 mm) larger than the sleeve diam. The sleeve is to be cast in place and may extend a max of 4 in. (102 mm) below the bottom of the deck and a max of 1 in. (25 mm) above the top surface of the concrete floor.

**2B. Sheet Metal Sleeve** — (Optional) - Max 12 in. (305 mm) diam, min 24 ga galv steel provided with a 24 ga galv steel square flange spot welded to the sleeve at approx mid-height, or flush with bottom of sleeve in floors, and sized to be a min of 2 in. (51 mm) larger than the sleeve diam. The sleeve is to be cast in place may extend a max of 4 in. below the bottom of the deck and a max of 1 in. (25 mm) above the top surface of the concrete floor.

**3. Through Penetrants** — One metallic pipe, conduit or tubing to be installed concentrically within the firestop device. Pipe, conduit or tubing to be rigidly supported on both sides of floor assembly. The annular space between pipe conduit or tubing and the periphery of the opening shall be min 0 in. (point contact) to max 1-7/8 in. (48 mm).

The following types of pipe, conduit or tubing may be used:

**Steel Pipe** — Nom 30 in. (762 mm) diam (or smaller) Schedule 10 (or heavier) steel pipe.

**Iron Pipe** — Nom 30 in. (762 mm) diam (or smaller) cast or ductile iron pipe.

**Conduit** — Nom 6 in. (152 mm) diam (or smaller) rigid steel conduit.

**Conduit** — Nom 4 in. (102 mm) diam (or smaller) steel electrical metallic conduit.

**Copper Tubing** — Nom 6 in. (152 mm) diam (or smaller) Type L (or heavier) copper tubing.

**Copper Pipe** — Nom 6 in. (152 mm) diam (or smaller) Regular (or heavier) copper pipe.

**4. Firestop System** — The firestop system shall consist of the following:

**A. Packing Material** — Min 2 in. (51 mm) in thickness of min 4 pcf (64 kg/m<sup>3</sup>) mineral wool batt insulation tightly packed into the opening as a permanent form. Packing material to be recessed from top surface of floor as required to accommodate the required thickness of fill material.

**B. Fill, Void or Cavity Materials\* - Sealant** — Min 1/2 in. (13 mm) thickness of fill material

applied within the annulus, flush with top surface of floor. At point contact, a min 1/2 in. (13 mm) diam bead of fill material shall be applied at the concrete/sleeve/pipe interface on top surface of floor.

**HILTI CONSTRUCTION CHEMICALS, DIV OF HILTI INC** — FS-ONE Sealant or FS-ONE MAX  
Intumescent Sealant

**\* Indicates such products shall bear the UL or cUL Certification Mark for jurisdictions employing the UL or cUL Certification (such as Canada), respectively.**

Last Updated on 2015-01-15

---

[Questions?](#)

[Print this page](#)

[Terms of Use](#)

[Page Top](#)

© 2015 UL LLC

When the UL Leaf Mark is on the product, or when the word "Environment" is included in the UL Mark, please search the [UL Environment database](#) for additional information regarding this product's certification.

The appearance of a company's name or product in this database does not in itself assure that products so identified have been manufactured under UL's Follow-Up Service. Only those products bearing the UL Mark should be considered to be Certified and covered under UL's Follow-Up Service. Always look for the Mark on the product.

UL permits the reproduction of the material contained in the Online Certification Directory subject to the following conditions: 1. The Guide Information, Assemblies, Constructions, Designs, Systems, and/or Certifications (files) must be presented in their entirety and in a non-misleading manner, without any manipulation of the data (or drawings). 2. The statement "Reprinted from the Online Certifications Directory with permission from UL" must appear adjacent to the extracted material. In addition, the reprinted material must include a copyright notice in the following format: "© 2015 UL LLC".



## System No. F-A-2025 XHEZ.F-A-2025 Through-penetration Firestop Systems

[Page Bottom](#)

### Design/System/Construction/Assembly Usage Disclaimer

- Authorities Having Jurisdiction should be consulted in all cases as to the particular requirements covering the installation and use of UL Certified products, equipment, system, devices, and materials.
- Authorities Having Jurisdiction should be consulted before construction.
- Fire resistance assemblies and products are developed by the design submitter and have been investigated by UL for compliance with applicable requirements. The published information cannot always address every construction nuance encountered in the field.
- When field issues arise, it is recommended the first contact for assistance be the technical service staff provided by the product manufacturer noted for the design. Users of fire resistance assemblies are advised to consult the general Guide Information for each product category and each group of assemblies. The Guide Information includes specifics concerning alternate materials and alternate methods of construction.
- Only products which bear UL's Mark are considered Certified.

### XHEZ - Through-penetration Firestop Systems

[See General Information for Through-penetration Firestop Systems](#)

#### System No. F-A-2025

January 15, 2015

**F Rating — 2 Hr**

**T Rating — 2 Hr**

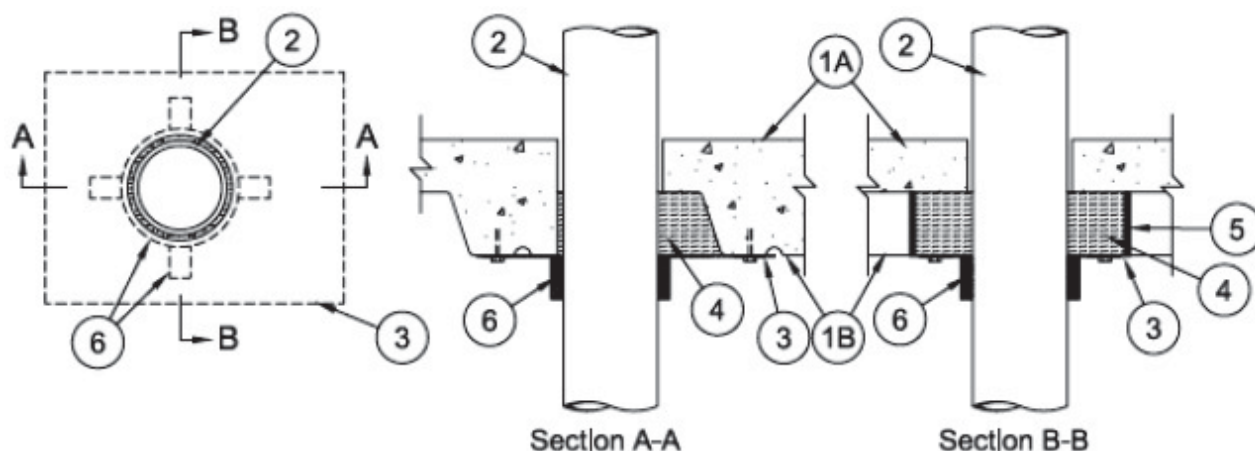

**1. Floor Assembly** — The fire-rated unprotected concrete and steel floor assembly shall be constructed of the materials and in the manner specified in the individual D900 Series designs in the UL Fire Resistance Directory and as summarized below:

**A. Normal Weight Concrete** — Min 2-1/2 in. (64 mm) thickness of lightweight or normal weight (100-150 pcf or 1600-2400 kg/m<sup>3</sup>) concrete topping as measured over the crests of the steel floor units.

**B. Steel Floor and Form Units\*** — Composite or noncomposite 3 in. (76 mm) deep fluted galv units as specified in the individual Floor-Ceiling design. Max diam of opening core-drilled through floor assembly is 8 in. (203 mm).

**2. Through Penetrants** — One nonmetallic pipe to be installed either concentrically or eccentrically within the firestop system. The annular space between pipe and periphery of opening shall be min 0 in. (0 mm, point contact) to max 1-1/2 in. (38 mm). Pipe to be rigidly supported on both sides of floor assembly. The following types and sizes of nonmetallic pipes may be used:

**A. Polyvinyl Chloride (PVC) Pipe** — Nom 6 in. (152 mm) diam (or smaller) Schedule 40 solid-core or cellular core PVC pipe for use in closed (process or supply) or vented (drain, waste or



vent) piping system.

**B. Chlorinated Polyvinyl Chloride (CPVC) Pipe** — Nom 6 in. (152 mm) diam (or smaller) SDR13.5 CPVC pipe for use in closed (process or supply) piping systems.

**C. Acrylonitrile Butadiene Styrene (ABS) Pipe** — Nom 6 in. (152 mm) diam (or smaller) Schedule 40 solid-core or cellular core ABS pipe for use in closed (process or supply) or vented (drain, waste or vent) piping systems.

**D. Flame Retardant Polypropylene (FRPP) Pipe** — Nom 6 in. (152 mm) diam (or smaller) Schedule 40 FRPP pipe for use in closed (process or supply) or vented drain, waste or vent) piping systems.

**3. Metal Plate Enclosure** — Min 18 ga steel. Width of plate to be min 12 in. (305 mm). Length of plate (transverse to steel floor unit direction) to extend to steel floor unit valley beyond each side of core-drilled hole with a min lap of 1-1/2 in. (38 mm) on the floor unit valley at each end. Both ends of plate perpendicular to floor unit valleys to be cut to permit the ends to be bent upwards 90 F deg to follow the contour of the floor unit, enclosing the packing material (Item 4) within the areas of the flutes. The contoured plate ends shall be such that the gap between the floor unit and the plate ends is no greater than 1/4 in. (6 mm). As an alternate to bending up ends of plate, min 1/4 in. (6 mm) thickness of fill material (Item 5) shall be applied to completely cover the surface of the mineral wool packing material within the flutes of the steel floor units, between the two ends of the metal enclosure plate and the steel floor units. Circular cutout in plate to tightly follow circumference of nonmetallic pipe with side edges of plate at least 3 in. (76 mm) from circular cutout on all sides. Slit made in plate to permit installation around the nonmetallic pipe to be located at end of plate beneath floor unit valley nearest to the circular cutout. Plate secured to valleys of floor unit using min 1/4 in. (6 mm) diam by 1-3/4 in. (45 mm) long steel expansion bolts, or equivalent, in conjunction with min 3/4 in. (19 mm) diam steel washers or min 0.145 in. (4 mm) diam by 1-1/4 in. (32 mm) long powder actuated fasteners utilizing a 1-7/16 in. (36 mm) diam by 1/16 in. (2 mm) thick steel washer. As alternates to the anchors specified above, Hilti 1/4 in. (6 mm) diam by 1-1/4 in. (32 mm) long KWIK-CON II+ concrete screw anchor, Hilti 1/4 in. (6 mm) diam by 1-3/4 in. (44 mm) long KWIK-BOLT 3 steel expansion anchor or Hilti X-DNI 27 P8 S15 powder actuated floor pin with integral nom 9/16 in. (15 mm) diam washer may be used. Fasteners to be located approx 1 in. (25 mm) from edges of plate at each corner, at each plate/valley intersection and at both sides of slit made to permit installation around nonmetallic pipe. Spacing of fasteners no to exceed 10 in. (254 mm) OC.

**4. Packing Material** — Mineral wool batt insulation having min density of 4 pcf (64 kg/m<sup>3</sup>), firmly packed into flutes of steel floor units above metal plate enclosure (Item 3) to completely fill cavities. When ends of metal plate enclosure perpendicular to floor unit valleys are not bent up to enclose packing material within flutes (see Item 3), packing material to be recessed from ends of plate to accommodate the required thickness of the fill material.

**5. Fill, Void or Cavity Material\* — Sealant** — Nom 1/2 in. (13 mm) bead of fill material applied around the perimeter of the metal plate enclosure at the interface of the enclosure and steel deck. When ends of metal plate enclosure (Item 3) are not bent up to enclose packing material within flutes, min 1/4 in. (6 mm) thickness of fill material shall be applied to completely cover the surface of the mineral wool packing material within the flutes of the steel floor units, between the two ends of the metal enclosure plate and the steel floor units.

**HILTI CONSTRUCTION CHEMICALS, DIV OF HILTI INC** — FS-One Sealant or FS-ONE MAX Intumescent Sealant

**6. Firestop Device\* — Firestop Collar** — Firestop collar shall be installed in accordance with the accompanying installation instructions. Collar to be installed and latched around the pipe and secured to the valley of the steel deck and to the metal plate enclosure using the anchor hooks provided with the collar. Min of two anchor hooks required for 1-1/2 and 2 in. (38 and 51 mm) diam pipes, min of three anchor hooks required for 3 and 4 in. (76 and 102 mm) diam pipes, and min of four anchor hooks required for 6 in. (152 mm) diam pipes. Where the anchor hooks are beneath the valley of the steel floor unit, the anchor tabs are to be secured with 1/4 in. (6 mm) diam by min 1-1/2 in. (38 mm) long steel expansion bolts, or equivalent, in conjunction with steel nuts and min 3/4 in. (19 mm) diam steel washers with one anchor bolt in each anchor hook. Where the anchor hooks are beneath the crest of the steel deck, the anchor hooks are to be secured to the metal enclosure with No. 10 by min 1/2 in. (13 mm) long self-drilling, self-tapping steel screws and min 3/4 in. (19 mm) diam steel washers.

**HILTI CONSTRUCTION CHEMICALS, DIV OF HILTI INC** — CP 643 50/1.5"N, CP 643 63/2"N, CP643 90/3"N, CP 643 110/4"N or CP 643 160/6"N Firestop Collar

**\* Indicates such products shall bear the UL or cUL Certification Mark for jurisdictions employing the UL or cUL Certification (such as Canada), respectively.**

Last Updated on 2015-01-15

[Questions?](#)

[Print this page](#)

[Terms of Use](#)

[Page Top](#)

© 2015 UL LLC

When the UL Leaf Mark is on the product, or when the word "Environment" is included in the UL Mark, please search the [UL Environment database](#) for additional information regarding this product's certification.

The appearance of a company's name or product in this database does not in itself assure that products so identified have been manufactured under UL's Follow-Up Service. Only those products bearing the UL Mark should be considered to be Certified and covered under UL's Follow-Up Service. Always look for the Mark on the product.

UL permits the reproduction of the material contained in the Online Certification Directory subject to the following conditions: 1. The Guide Information, Assemblies, Constructions, Designs, Systems, and/or Certifications (files) must be presented in their entirety and in a non-

misleading manner, without any manipulation of the data (or drawings). 2. The statement "Reprinted from the Online Certifications Directory with permission from UL" must appear adjacent to the extracted material. In addition, the reprinted material must include a copyright notice in the following format: "© 2015 UL LLC".



## System No. F-A-3012 XHEZ.F-A-3012 Through-penetration Firestop Systems

[Page Bottom](#)

### Design/System/Construction/Assembly Usage Disclaimer

- Authorities Having Jurisdiction should be consulted in all cases as to the particular requirements covering the installation and use of UL Certified products, equipment, system, devices, and materials.
- Authorities Having Jurisdiction should be consulted before construction.
- Fire resistance assemblies and products are developed by the design submitter and have been investigated by UL for compliance with applicable requirements. The published information cannot always address every construction nuance encountered in the field.
- When field issues arise, it is recommended the first contact for assistance be the technical service staff provided by the product manufacturer noted for the design. Users of fire resistance assemblies are advised to consult the general Guide Information for each product category and each group of assemblies. The Guide Information includes specifics concerning alternate materials and alternate methods of construction.
- Only products which bear UL's Mark are considered Certified.

### XHEZ - Through-penetration Firestop Systems

#### XHEZ7 - Through-penetration Firestop Systems Certified for Canada

[See General Information for Through-penetration Firestop Systems](#)

[See General Information for Through-penetration Firestop Systems Certified for Canada](#)

### System No. F-A-3012

January 16, 2015

ANSI/UL1479 (ASTM E814)	CAN/ULC S115
F Rating — 3 Hr	F Rating — 3 Hr
T Ratings - 0, 1/2 and 3/4 Hr (See Item 3)	FT Ratings - 0, 1/2 and 3/4 Hr (See Item 3)
	FH Rating — 3 Hr
	FTH Ratings - 0, 1/2 and 3/4 Hr (See Item 3)

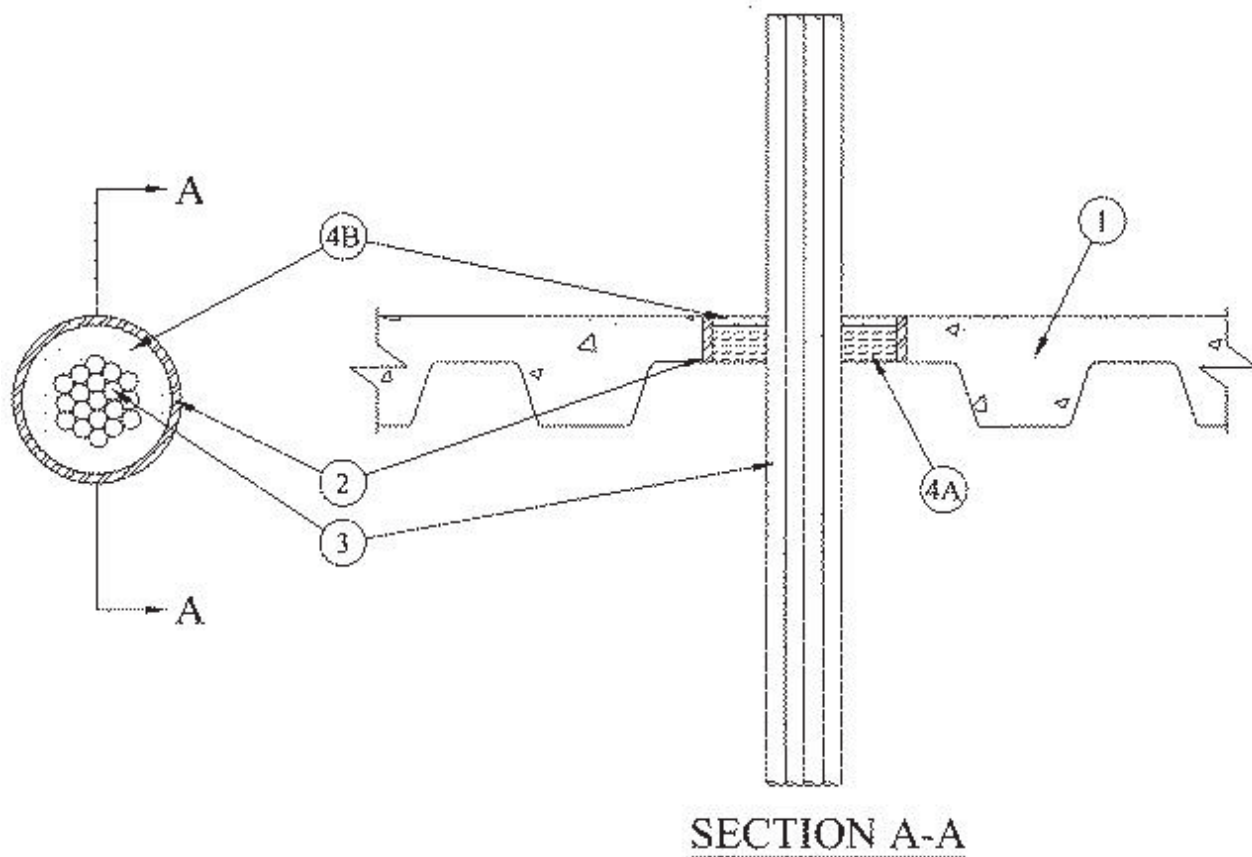

### SECTION A-A

**1. Floor Assembly** — The fire rated unprotected concrete and steel floor assembly shall be constructed of the materials and in the manner specified in the individual D900 Series designs in the UL Fire Resistance Directory and as summarized below.

A. **Concrete** — Min 2-1/2 in (64 mm) thick reinforced lightweight or normal weight (100-150 pcf or 1600-2400 kg/m<sup>3</sup>) concrete.

B. **Steel Floor and Form Units\*** — Composite or non-composite max 3 in. (76 mm) deep galv steel fluted units as specified in the individual Floor-Ceiling Design. Max diam of opening is 6 in. (152 mm).

**2. Steel Sleeve** — (Optional)- Nom 6 in. (152 mm) diam (or smaller) Schedule 40 (or heavier) steel sleeve cast or grouted into floor assembly, flush with floor surfaces.

**3. Cables** — Aggregate cross-sectional area of bundled cables in opening to be min 25 percent to max 45 percent of the cross-sectional area of the opening. Cables to be rigidly supported on both sides of the floor or wall assembly. Any combination of the following types and sizes of cables may be used.

A. Max 300 pair No. 24 AWG telecommunication cable with PVC insulation and jacket. **When telecommunication cable is used, T, FT and FTH Rating is 0 hr**

B. Max 500 kcmil single copper connector power cable with thermoplastic insulation and polyvinyl chloride (PVC) jacket. **When single copper conductor power cable is used, T, FT and FTH Rating is 0 hr**

C. Max 350 kcmil single connector power cable with either aluminum or copper conductors with cross-linked polyethylene (XLPE) insulation and polyvinyl chloride (PVC) jacket. **When single aluminum conductor power cable is used, T, FT and FTH Rating is 0 hr. When single copper conductor power cable is used, T Rating is 1/2 hr.**

D. Max three copper connector No. 6 AWG cable with polyvinyl chloride (PVC) insulation and jacket material. **When multi-conductor power cable is used, T, FT and FTH Rating is 0 hr.**

E. Max 7/C copper connector No. 12 AWG multiconductor power and control cable with polyvinyl chloride (PVC) or cross-linked polyethylene (XLPE) insulation and PVC jacket. **When multi-conductor power cable is used, T, FT and FTH Rating is 3/4 hr.**

F. Multiple fiber optical communication cable jacketed with PVC and having a max outside diameter of 1/2 in. **When fiber optic cable is used, T, FT and FTH Rating is 3/4 hr.**

G. Max 3/C No. 12 AWG with bare aluminum ground, polyvinyl chloride (PVC) insulated steel Metal-Clad cable+. **When MC cable is used, T, FT**

**4. Firestop System** — The firestop system shall consist of the following:

A. **Packing Materials** — Min 2 in (51 mm) thickness of min 4 pcf (64 kg/m<sup>3</sup>) mineral wool batt insulation firmly packed into opening as a permanent form. Packing material to be recessed from top surface of floor to accommodate the required thickness of fill material.

B. **Fill, Void or Cavity Materials\* - Sealant** — Min 1/2 in. (13 mm) thickness of fill material applied within the annulus, flush with top surface of floor.

**HILTI CONSTRUCTION CHEMICALS, DIV OF HILTI INC** — FS-ONE Sealant or FS-ONE MAX Intumescent Sealant

**\* Indicates such products shall bear the UL or cUL Certification Mark for jurisdictions employing the UL or cUL Certification (such as Canada), respectively.**

Last Updated on 2015-01-16

[Questions?](#)

[Print this page](#)

[Terms of Use](#)

[Page Top](#)

© 2015 UL LLC

When the UL Leaf Mark is on the product, or when the word "Environment" is included in the UL Mark, please search the [UL Environment database](#) for additional information regarding this product's certification.

The appearance of a company's name or product in this database does not in itself assure that products so identified have been manufactured under UL's Follow-Up Service. Only those products bearing the UL Mark should be considered to be Certified and covered under UL's Follow-Up Service. Always look for the Mark on the product.

UL permits the reproduction of the material contained in the Online Certification Directory subject to the following conditions: 1. The Guide Information, Assemblies, Constructions, Designs, Systems, and/or Certifications (files) must be presented in their entirety and in a non-misleading manner, without any manipulation of the data (or drawings). 2. The statement "Reprinted from the Online Certifications Directory with permission from UL" must appear adjacent to the extracted material. In addition, the reprinted material must include a copyright notice in the following format: "© 2015 UL LLC".



## System No. HW-D-0029 XHBN.HW-D-0029 Joint Systems

Page Bottom

### Design/System/Construction/Assembly Usage Disclaimer

- Authorities Having Jurisdiction should be consulted in all cases as to the particular requirements covering the installation and use of UL Certified products, equipment, system, devices, and materials.
- Authorities Having Jurisdiction should be consulted before construction.
- Fire resistance assemblies and products are developed by the design submitter and have been investigated by UL for compliance with applicable requirements. The published information cannot always address every construction nuance encountered in the field.
- When field issues arise, it is recommended the first contact for assistance be the technical service staff provided by the product manufacturer noted for the design. Users of fire resistance assemblies are advised to consult the general Guide Information for each product category and each group of assemblies. The Guide Information includes specifics concerning alternate materials and alternate methods of construction.
- Only products which bear UL's Mark are considered Certified.

### XHBN - Joint Systems

See General Information for Joint Systems

## System No. HW-D-0029

April 07, 2015

**Assembly Ratings — 1 and 2 Hr (See Items 2 and 3B)**

**L Rating at Ambient — Less than 1 CFM/Lin Ft**

**L Rating at 400 F — Less than 1 CFM/Lin Ft**

**Nominal Joint Width — 1 In.**

**Class II Movement Capabilities — 25% Compression or Extension**

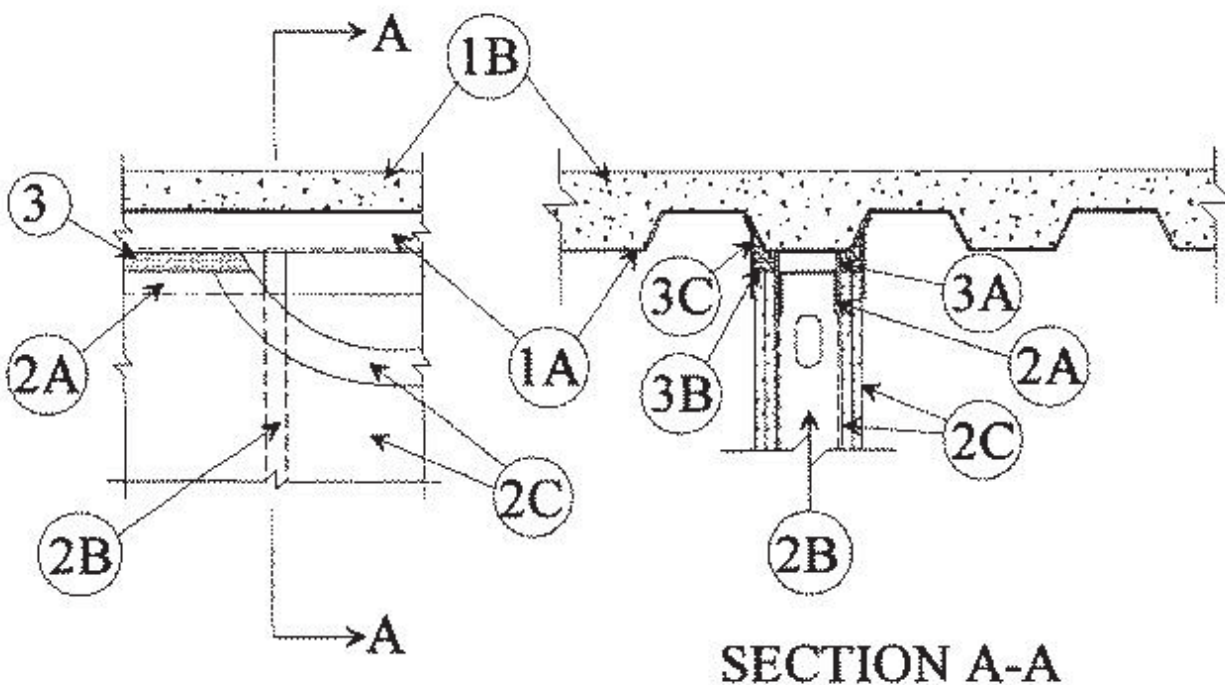

1. **Floor Assembly** — The fire-rated fluted steel deck/concrete floor assembly shall be constructed of the materials and in the manner described in the individual D700 or D900 Series Floor-Ceiling Design in the UL Fire Resistance Directory and shall include the following construction features:

A. **Steel Floor And Form Units\*** — Max 3 in. (76 mm) deep galv steel fluted floor deck .

A1. **Spray Applied Fire Resistive Material\*** — (Optional, not shown) — Prior to the installation of the Deflective Channel, Forming Material and Fill, Void or Cavity Materials (Items 3A and 3B), the steel floor units may be sprayed with a min 5/16 in. (8 mm) to max 11/16 in. (18 mm) thickness of fire resistive material.

**W R GRACE & CO - CONN** — Type MK-6/HY.

B. **Concrete** — Min 2-1/2 in. (64 mm) thick reinforced concrete, as measured from the top plane of the floor units.

1A. **Roof Assembly** — (Not Shown)—As an alternate to the floor assembly, a fire rated fluted steel deck roof assembly may be used. The roof assembly shall be constructed of the materials and in the manner described in the individual P900 Series Roof-Ceiling Design in the UL Fire Resistance Directory. **The hourly rating of the roof assembly shall be equal to or greater than the hourly rating of the wall assembly.** The roof assembly shall include the following construction features:

A. **Steel Roof Deck** — Max 3 in. (76 mm) deep galv steel fluted roof deck.

B. **Roof Insulation** — Min 2-1/4 in. (57 mm) thick poured insulating concrete, as measured from the top plane of the floor units.

2. **Wall Assembly** — The 1 or 2 hr fire rated gypsum board/steel stud wall assembly shall be constructed of the materials and in the manner described in the individual U400 or V400- Series Wall and Partition Design in the UL Fire Resistance Directory and shall include the following construction features:

A. **Steel Floor And Ceiling Runners** — Floor and ceiling runners of wall assembly shall consist of galv steel channels sized to accommodate steel studs (Item 2B). When deflection channel (Item 3A) is used, ceiling runner to be provided with 3 in. (76 mm) flanges. Ceiling runner installed within the deflection channel with 1 in. (25 mm) gap maintained between the top of ceiling runner and top of deflection channel. When deflection channel is not used, flange height of ceiling runner shall be min 3/4 in. (19 mm) greater than nom joint width. Ceiling runner installed parallel to direction of fluted steel deck, centered beneath valley, and secured with steel masonry anchors or by welds spaced max 24 in. (610 mm) OC. When optional spray-applied fire resistive material is used on the steel deck and when deflection channel is not used, ceiling runner is secured through spray-applied material to valley of floor steel deck with min 3/16 in. (5 mm) diam steel masonry anchors spaced max 12 in. (305 mm) OC.

A1. **Light Gauge Framing\*- Slotted Ceiling Runner** — As an alternate to the ceiling runner in Item 2A, slotted ceiling runner to consist of galv steel channel with slotted flanges sized to accommodate steel studs (Item 2B). Slotted ceiling runner installed parallel to direction of fluted steel deck, centered beneath valley, and secured with steel masonry anchors spaced max 24 in. (610 mm) OC. When slotted ceiling runner is used, deflection channel (Item 3A) shall not be used. When optional spray-applied fire resistive material is used on the steel floor slotted ceiling runner secured through spray-applied material to valley of steel deck with min 3/16 in. (5 mm) diam steel masonry anchors spaced max 12 in. (305 mm) OC.

**BRADY CONSTRUCTION INNOVATIONS INC, DBA SLIPTRACK SYSTEMS** — SLP-TRK

**CALIFORNIA EXPANDED METAL PRODUCTS CO** — CST

**CLARKDIETRICH BUILDING SYSTEMS** — Type SLT, SLT-H

**MARINO/WARE, DIV OF WARE INDUSTRIES INC** — Type SLT

**SCAFCO STEEL STUD MANUFACTURING CO**

**STEELER INC** — Steeler Slotted Ceiling Runner

**TELLING INDUSTRIES L L C** — True-Action Deflection Track

A2. **Light Gauge Framing —Floor and Ceiling Runners** — As an alternate to the ceiling and floor runners in Item 2A, 2A1 and 2A2, floor and ceiling runners to consist of galv steel channel sized to accommodate the **Light Gauge Framing\* Slotted Stud** (Item 2B1) or **Light Gauge Framing\* Slider C-Clip System** (Item 2B2). Floor and ceiling runners to be provided with min 1-1/4 in. and 3 in. (32 and 76 mm) flanges, respectively. Ceiling runner installed parallel to direction of steel deck, centered beneath valley, and secured with steel masonry anchors spaced

max 12 in. (305 mm) OC. When ceiling runner is used, deflection channel (Item 3A) shall not be used. When optional spray-applied fire resistive material is used on steel deck, ceiling runner secured through spray-applied material to valley of the steel deck with min 3/16 in. (5 mm) diam steel masonry anchors spaced max 12 in. (305 mm) OC.

**STEELER INC** — Floor and Ceiling Runners

**A3. Light Gauge Framing\* - Notched Ceiling Runner** — As an alternate to the ceiling runners in Items 2A through 2A3, notched ceiling runners to consist of C-shaped galv steel channel with notched return flanges sized to accommodate steel studs (Item 2B). Notched ceiling runner installed parallel to direction of steel centered on valley, and secured with steel masonry anchors spaced max 24 in. (610 mm) OC. When notched ceiling runner is used, deflection channel (Item 3A) shall not be used. When optional spray-applied fire resistive material is used on the steel deck, notched ceiling runner secured through spray-applied material to valley of deck with min 3/16 in. (5 mm) diam steel masonry anchors spaced max 12 in. (305 mm) OC.

**OLMAR SUPPLY INC** — Type SCR

**A4. Light Gauge Framing\* —Floor and Ceiling Runners** — As an alternate to the ceiling and floor runners in Item 2A, through 2A4, floor and ceiling runners to consist of galv steel channel sized to accommodate the **Light Gauge Framing\* Steel Studs** (Item 2B3). Floor and ceiling runners to be provided with min 1-3/4 in. flanges. Ceiling runner installed parallel to direction of steel deck, centered beneath valley, and secured to valleys with steel masonry anchors spaced max 12 in. (305 mm) OC. When ceiling runner is used, deflection channel (Item 3A) shall not be used. When optional spray-applied fire resistive material is used on the steel deck, ceiling runner is secured through spray-applied material to each valley of steel deck with min 3/16 in. (5 mm) diam steel masonry anchors spaced max 12 in. (305 mm) OC.

**CALIFORNIA EXPANDED METAL PRODUCTS CO** — ViperTrack™

**B. Studs** — Steel studs to be min 3-1/2 in. (89 mm) wide. Studs cut 1/2 to 3/4 in. (13 to 19 mm) less in length than assembly height with bottom nesting in and resting on floor runner and with top nesting in ceiling runner without attachment. When slotted ceiling runner (Item 2A1) is used, steel studs secured to slotted ceiling runner with No. 8 by 1/2 in. (13 mm) long wafer head steel screws at midheight of slot on each side of wall. Stud spacing not to exceed 24 in. (610 mm) OC.

**B1. Light Gauge Framing\* —Slotted Studs** — Slotted steel stud to be used in conjunction with **Light Gauge Framing\* —Floor and Ceiling Runners** (Item 2A3). Slotted steel studs to be min 3-1/2 in. (89 mm) wide. Slotted studs cut 1 in. (25 mm) less in length than assembly height with bottom nesting in and secured to both ceiling and floor runners. Ceiling runner secured to preformed slot within steel stud by means of No. 10 by 3/4 in. (19 mm) long low profile head steel screw. Floor runner attached to bottom of steel stud by means of No. 8 by 1/2 in. (13 mm) long pan head steel screw. Slotted stud spacing not to exceed 24 in. (610 mm) OC.

**STEELER INC** — Slotted Stud

**B2. Light Gauge Framing\* —Slider C-Clip System** — As an alternate to the **Light Gauge Framing\* —Slotted Steel Studs** (Item 2B1), a Slider C-Clip System consisting of a C shaped steel clip with a slotted opening and a steel stud to be used in conjunction with **Light Gauge Framing —Floor and Ceiling Runners** (Item 2A3). Steel clips and studs to be min 3-1/2 in. (89 mm) wide. Steel clip inserted into inside flange of steel stud without attachment. Total length of steel stud cut 1 in. (25 mm) less than assembly height with bottom of steel stud nesting in and secured to floor runner. Floor runner attached to bottom of steel stud by means of No. 8 by 1/2 in. (13 mm) long pan head steel screw. Ceiling runner secured to steel C-Clip by means of No. 10 by 3/4 in. (19 mm) long pan head steel screw located 3/8 in. (10 mm) below top of ceiling runner. Top row of gypsum board screws shall be centered within the preformed slot of the C-Clip. Steel stud and steel clips spacing not to exceed 24 in. (610 mm) OC.

**STEELER INC** — Slider C Clip System

**B3. Light Gauge Framing\* — Steel Studs** — Steel Studs to be used in conjunction with **Light Gauge Framing\* —Floor and Ceiling Runners** (Item 2A5). Steel studs to be min 3-5/8 in. (92 mm) wide. Studs cut 1/2 to 3/4 in. (13 to 19 mm) less in length than assembly height with bottom nesting in and resting on floor runner and with top nesting in ceiling runner without attachment. When slotted ceiling runner (Item 2A1) is used, steel studs secured to slotted ceiling runner with No. 8 by 1/2 in. (13 mm) long wafer head steel screws at midheight of slot on each side of wall. Stud spacing not to exceed 24 in (610 mm) OC.

**CALIFORNIA EXPANDED METAL PRODUCTS CO** — ViperStud™



C. **Gypsum Board\*** — Gypsum board sheets installed to a min total thickness of 5/8 in. and 1-1/4 in. (16 and 32 mm) on each side of wall for 1 and 2 hr rated assemblies, respectively. Wall to be constructed as specified in the individual Wall and Partition Design in the UL Fire Resistance Directory, except that a nom 1 in. (25 mm) gap shall be maintained between the top of the gypsum board and the bottom of the steel floor or roof deck and the top row of screws shall be installed into the studs 3-1/2 in. (89 mm) below the lower surface of the floor. **The hourly rating of the joint system is equal to the hourly fire rating of the wall.**

**3. Joint System — Max separation between bottom of floor or roof and top of wall is 1 in. (25 mm). The joint system is designed to accommodate a max 25 percent compression or extension from its installed width.**

The joint system consists of an optional deflection channel, forming material and a fill material, as follows:

A. **Deflection Channel - (Optional)** — A nom 3-5/8 in. (92 mm) wide by 3 in. (76 mm) deep min 24 ga steel U-shaped channel. Deflection channel installed parallel to direction of steel deck, centered beneath valley and secured with steel masonry anchors or by welds spaced max 24 in. (610 mm) OC. When optional spray- applied fire resistive material is used on the steel deck, deflection channel secured through spray- applied material to valley of steel deck with min 1-1/2 in. (38 mm) long by min 3/16 in. (5 mm) diam steel masonry anchors spaced a max 24 in. (610 mm) OC. The ceiling runner (Item 2A) is installed within the deflection channel to maintain a 1 in. (25 mm) gap between the top of the ceiling runner and the top of the deflection channel. The ceiling runner is not fastened to the deflection channel.

B. **Forming Material\*** — Min 4 pcf (64 kg/m<sup>3</sup>) mineral wool batt insulation to be cut a min of 20 percent wider than the gap between the top of the gypsum board and bottom of the steel floor or roof deck. The mineral wool is to be compressed and firmly packed into the gap between the top of the gypsum board and bottom of the steel floor or roof deck on both sides of the wall and shall be min 3/4 in. (19 mm) thick for 1 hr Rated Design and min 1-1/2 in. (38 mm) thick for 2 hr Rated Design.

**IIG MINWOOL L L C** — MinWool-1200 Safing

**ROCK WOOL MANUFACTURING CO** — Delta Board or Delta-8

**ROCKWOOL MALAYSIA SDN BHD** — Type Safe

**ROXUL INC** — Type Safe

**THERMAFIBER INC** — Type SAF

C. **Fill, Void or Cavity Material\*** — Min 1/16 in. (1.6 mm) dry thickness (1/8 in. or 3.2 mm wet thickness) of fill material sprayed or brushed on each side of the wall between the top of the gypsum board and the bottom of the steel floor or roof deck to completely cover mineral wool and overlap a min of 1/2 in. (13 mm) onto gypsum board and steel deck on both sides of wall. When the steel deck is coated with spray applied Material (Item A1), the fill material shall overlap min 2 in. (51 mm) onto the spray applied material.

**3M COMPANY** — Fire Dam™ Spray 200

**\* Indicates such products shall bear the UL or cUL Certification Mark for jurisdictions employing the UL or cUL Certification (such as Canada), respectively.**

Last Updated on 2015-04-07

[Questions?](#)

[Print this page](#)

[Terms of Use](#)

[Page Top](#)

© 2015 UL LLC

When the UL Leaf Mark is on the product, or when the word "Environment" is included in the UL Mark, please search the [UL Environment database](#) for additional information regarding this product's certification.

The appearance of a company's name or product in this database does not in itself assure that products so identified have been manufactured under UL's Follow-Up Service. Only those products bearing the UL Mark should be considered to be Certified and covered under UL's Follow-Up Service. Always look for the Mark on the product.

UL permits the reproduction of the material contained in the Online Certification Directory subject to the following conditions: 1. The Guide Information, Assemblies, Constructions, Designs, Systems, and/or Certifications (files) must be presented in their entirety and in a non-misleading manner, without any manipulation of the data (or drawings). 2. The statement "Reprinted from the Online Certifications Directory with permission from UL" must appear adjacent to the extracted material. In addition, the reprinted material must include a copyright notice in the following format: "© 2015 UL LLC".



## System No. W-L-7001 XHEZ.W-L-7001 Through-penetration Firestop Systems

[Page Bottom](#)

### Design/System/Construction/Assembly Usage Disclaimer

- Authorities Having Jurisdiction should be consulted in all cases as to the particular requirements covering the installation and use of UL Certified products, equipment, system, devices, and materials.
- Authorities Having Jurisdiction should be consulted before construction.
- Fire resistance assemblies and products are developed by the design submitter and have been investigated by UL for compliance with applicable requirements. The published information cannot always address every construction nuance encountered in the field.
- When field issues arise, it is recommended the first contact for assistance be the technical service staff provided by the product manufacturer noted for the design. Users of fire resistance assemblies are advised to consult the general Guide Information for each product category and each group of assemblies. The Guide Information includes specifics concerning alternate materials and alternate methods of construction.
- Only products which bear UL's Mark are considered Certified.

### XHEZ - Through-penetration Firestop Systems

[See General Information for Through-penetration Firestop Systems](#)

#### System No. W-L-7001

May 01, 1997

**F Rating — 1 Hr**

**T Rating — 0 Hr**

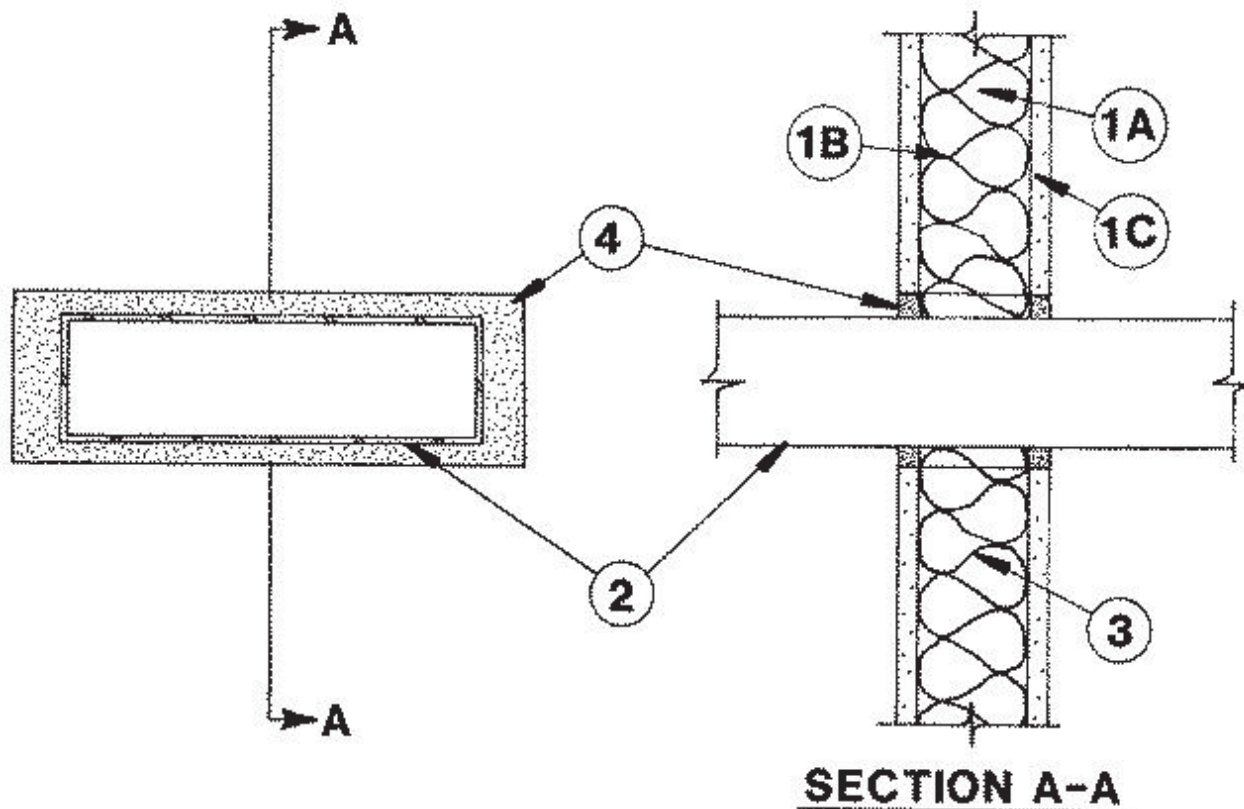

**1. Wall Assembly** — The fire-rated gypsum wallboard/stud wall assembly shall be constructed of the materials and in the manner described in the individual U300 or U400 Series Wall and Partition Designs in the UL Fire Resistance Directory and shall include the following construction features:

A. **Studs** — Wall framing may consist of either wood studs or steel channel studs. Wood studs to consist of nom 2 by 4 in. lumber spaced 16 in. OC. Steel studs to be min 2-1/2 in. wide and spaced max 24 in. OC.

B. **Batts and Blankets\*** — Nom 1-1/2 in. thick glass fiber batts friction fitted to fill interior of stud cavities.

C. **Gypsum Board\*** — The gypsum wallboard type, thickness, number of layers and orientation shall be as specified in the individual wall and partition Design. Max area of opening is 48 sq in. with max dimension of 12 in.

2. **Air Duct** — Prefabricated 24 MSG sheet metal air duct. Max cross sectional area of duct is 30 sq in. with max dimension of 10 in. A min 7/16 to max 1-5/8 in. annular space is required within the firestop system. Air duct to be rigidly supported on both sides of wall assembly.

3. **Forming Material\*** — Min 2-1/2 in. thickness of min 3.5 pcf mineral wool batt insulation firmly packed into opening as a permanent form. Forming material to be recessed from both surfaces of wall to accommodate the required thickness of fill material.

**THERMAFIBER INC** — Type SAF

4. **Fill, Void or Cavity Material\* — Sealant** — Min 1/2 in. thickness of fill material applied within the annulus, flush with both surfaces of wall. Dry mix material mixed with water at a rate of 2.1 parts dry mix to 1 lb part water by weight in accordance with the accompanying installation instructions.

**UNITED STATES GYPSUM CO** — Type FC

4A. **Fill, Void or Cavity Material\*** — Not Shown — Two component fill material used as an alternate to Item 4. Min 1/2 in. thickness of fill material applied within the annulus, flush with both surfaces of wall. Ready-mixed component mixed with accelerator component at a rate of 66 parts of ready-mixed component to 1 part of accelerator component by weight in accordance with the accompanying installation instructions.

**UNITED STATES GYPSUM CO** — Type RFC

**\* Indicates such products shall bear the UL or cUL Certification Mark for jurisdictions employing the UL or cUL Certification (such as Canada), respectively.**

Last Updated on 1997-05-01

[Questions?](#)

[Print this page](#)

[Terms of Use](#)

[Page Top](#)

© 2015 UL LLC

When the UL Leaf Mark is on the product, or when the word "Environment" is included in the UL Mark, please search the [UL Environment database](#) for additional information regarding this product's certification.

The appearance of a company's name or product in this database does not in itself assure that products so identified have been manufactured under UL's Follow-Up Service. Only those products bearing the UL Mark should be considered to be Certified and covered under UL's Follow-Up Service. Always look for the Mark on the product.

UL permits the reproduction of the material contained in the Online Certification Directory subject to the following conditions: 1. The Guide Information, Assemblies, Constructions, Designs, Systems, and/or Certifications (files) must be presented in their entirety and in a non-misleading manner, without any manipulation of the data (or drawings). 2. The statement "Reprinted from the Online Certifications Directory with permission from UL" must appear adjacent to the extracted material. In addition, the reprinted material must include a copyright notice in the following format: "© 2015 UL LLC".



## System No. W-L-1054 XHEZ.W-L-1054 Through-penetration Firestop Systems

[Page Bottom](#)

### Design/System/Construction/Assembly Usage Disclaimer

- Authorities Having Jurisdiction should be consulted in all cases as to the particular requirements covering the installation and use of UL Certified products, equipment, system, devices, and materials.
- Authorities Having Jurisdiction should be consulted before construction.
- Fire resistance assemblies and products are developed by the design submitter and have been investigated by UL for compliance with applicable requirements. The published information cannot always address every construction nuance encountered in the field.
- When field issues arise, it is recommended the first contact for assistance be the technical service staff provided by the product manufacturer noted for the design. Users of fire resistance assemblies are advised to consult the general Guide Information for each product category and each group of assemblies. The Guide Information includes specifics concerning alternate materials and alternate methods of construction.
- Only products which bear UL's Mark are considered Certified.

### XHEZ - Through-penetration Firestop Systems

### XHEZ7 - Through-penetration Firestop Systems Certified for Canada

[See General Information for Through-penetration Firestop Systems](#)

[See General Information for Through-penetration Firestop Systems Certified for Canada](#)

### System No. W-L-1054

January 23, 2015

ANSI/UL1479 (ASTM E814)	CAN/ULC S115
F Ratings —1 and 2 Hr (See Items 1 and 3)	F Ratings — 1 and 2 Hr (See Items 1 and 3)
T Rating — 0 Hr	FT Rating — 0 Hr
L Rating at Ambient — Less Than 1 CFM/sq ft	FH Ratings —1 and 2 Hr (See Items 1 and 3)
L Rating at 400 F — Less Than 1 CFM/sq ft	FTH Rating — 0 Hr
	FTH Rating — 0 Hr L Rating at Ambient — Less Than 1 CFM/sq ft
	L Rating at 400 F — Less Than 1 CFM/sq ft

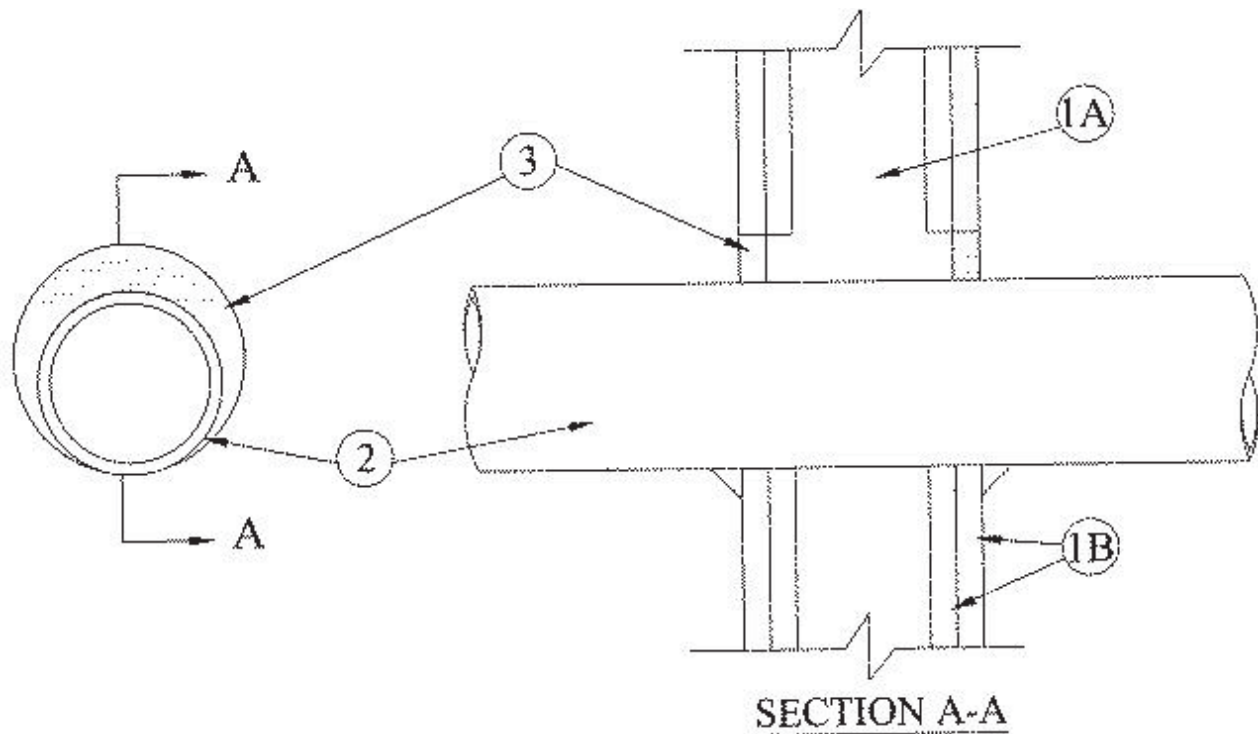

**1. Wall Assembly** — The 1 or 2 hr fire-rated gypsum wallboard/stud wall assembly shall be constructed of the materials and in the manner specified in the individual U300 or U400 Series Wall and Partition Designs in the UL Fire Resistance Directory and shall include the following construction features:

**A. Studs** — Wall framing may consist of either wood studs or steel channel studs. Wood studs to consist of nom 2 by 4 in. (51 by 102 mm) lumber spaced 16 in. (406 mm) OC. Steel studs to be min 2-1/2 in. (64 mm) wide and spaced max 24 in. (610 mm) OC. When steel studs are used and the diam of opening exceeds the width of stud cavity, the opening shall be framed on all sides using lengths of steel stud installed between the vertical studs and screw-attached to the steel studs at each end. The framed opening in the wall shall be 4 to 6 in. (102 to 152 mm) wider and 4 to 6 in. (102 to 152 mm) higher than the diam of the penetrating item such that, when the penetrating item is installed in the opening, a 2 to 3 in. (51 to 76 mm) clearance is present between the penetrating item and the framing on all four sides.

**B. Gypsum Board\*** — 5/8 in. (16 mm) thick, 4 ft (122 cm) wide with square or tapered edges. The gypsum board type, thickness, number of layers, fastener type and sheet orientation shall be as specified in the individual U300 or U400 Series Design in the UL Fire Resistance Directory. Max diam of opening is 32-1/4 in. (819 mm) for steel stud walls. Max diam of opening is 14-1/2 in. (368 mm) for wood stud walls.

**The F and FH Ratings of the firestop system are equal to the fire rating of the wall assembly.**

**2. Through-Penetrants** — One metallic pipe, conduit or tubing to be installed either concentrically or eccentrically within the firestop system. The annular space shall be min 0 in. to max 2-1/4 in. (57 mm). Pipe may be installed with continuous point contact. Pipe, conduit or tubing may be installed at an angle not greater than 45 degrees from perpendicular. Pipe, conduit or tubing to be rigidly supported on both sides of wall assembly. The following types and sizes of metallic pipes, conduits or tubing may be used:

**A. Steel Pipe** — Nom 30 in. (762 mm) diam (or smaller) Schedule 10 (or heavier) steel pipe.

**B. Iron Pipe** — Nom 30 in. (762 mm) diam (or smaller) cast or ductile iron pipe.

**C. Conduit** — Nom 4 in. (102 mm) diam (or smaller) steel electrical metallic tubing or 6 in. (152 mm) . diam steel conduit.

**D. Copper Tubing** — Nom 6 in. (152 mm) diam (or smaller) Type L (or heavier) copper tubing.

**E. Copper Pipe** — Nom 6 in. (152 mm) diam (or smaller) regular (or heavier) copper pipe.

**3. Fill, Void or Cavity Material\* — Sealant** — Min 5/8 in. (16 mm) thickness of fill material applied within the annulus, flush with both surfaces of wall. At the point or continuous contact locations between pipe and wall, a min 1/2 in. (13 mm) diam bead of fill material shall be applied at the pipe wall interface on both surfaces of wall.

**HILTI CONSTRUCTION CHEMICALS, DIV OF HILTI INC** — FS-One Sealant or FS-ONE MAX Intumescent Sealant

**\* Indicates such products shall bear the UL or cUL Certification Mark for jurisdictions employing the UL or cUL Certification (such as Canada), respectively.**

[Questions?](#)[Print this page](#)[Terms of Use](#)[Page Top](#)

© 2015 UL LLC

When the UL Leaf Mark is on the product, or when the word "Environment" is included in the UL Mark, please search the [UL Environment database](#) for additional information regarding this product's certification.

The appearance of a company's name or product in this database does not in itself assure that products so identified have been manufactured under UL's Follow-Up Service. Only those products bearing the UL Mark should be considered to be Certified and covered under UL's Follow-Up Service. Always look for the Mark on the product.

UL permits the reproduction of the material contained in the Online Certification Directory subject to the following conditions: 1. The Guide Information, Assemblies, Constructions, Designs, Systems, and/or Certifications (files) must be presented in their entirety and in a non-misleading manner, without any manipulation of the data (or drawings). 2. The statement "Reprinted from the Online Certifications Directory with permission from UL" must appear adjacent to the extracted material. In addition, the reprinted material must include a copyright notice in the following format: "© 2015 UL LLC".



## System No. W-L-1085 XHEZ.W-L-1085 Through-penetration Firestop Systems

[Page Bottom](#)

### Design/System/Construction/Assembly Usage Disclaimer

- Authorities Having Jurisdiction should be consulted in all cases as to the particular requirements covering the installation and use of UL Certified products, equipment, system, devices, and materials.
- Authorities Having Jurisdiction should be consulted before construction.
- Fire resistance assemblies and products are developed by the design submitter and have been investigated by UL for compliance with applicable requirements. The published information cannot always address every construction nuance encountered in the field.
- When field issues arise, it is recommended the first contact for assistance be the technical service staff provided by the product manufacturer noted for the design. Users of fire resistance assemblies are advised to consult the general Guide Information for each product category and each group of assemblies. The Guide Information includes specifics concerning alternate materials and alternate methods of construction.
- Only products which bear UL's Mark are considered Certified.

### XHEZ - Through-penetration Firestop Systems

### XHEZ7 - Through-penetration Firestop Systems Certified for Canada

[See General Information for Through-penetration Firestop Systems](#)

[See General Information for Through-penetration Firestop Systems Certified for Canada](#)

### System No. W-L-1085

January 23, 2015

ANSI/UL1479 (ASTM E814)	CAN/ULC S115
F Rating — 1 and 2 Hr (See Item 1B)	F Rating — 1 and 2 Hr (See Item 1B)
T Rating — 0 Hr	FT Rating — 0 Hr
L Rating At Ambient — Less Than 1 CFM/sq ft	FH Rating — 1 and 2 Hr (See Item 1B)
L Rating At 400 F — 4 CFM/sq ft	FTH Rating — 0 Hr

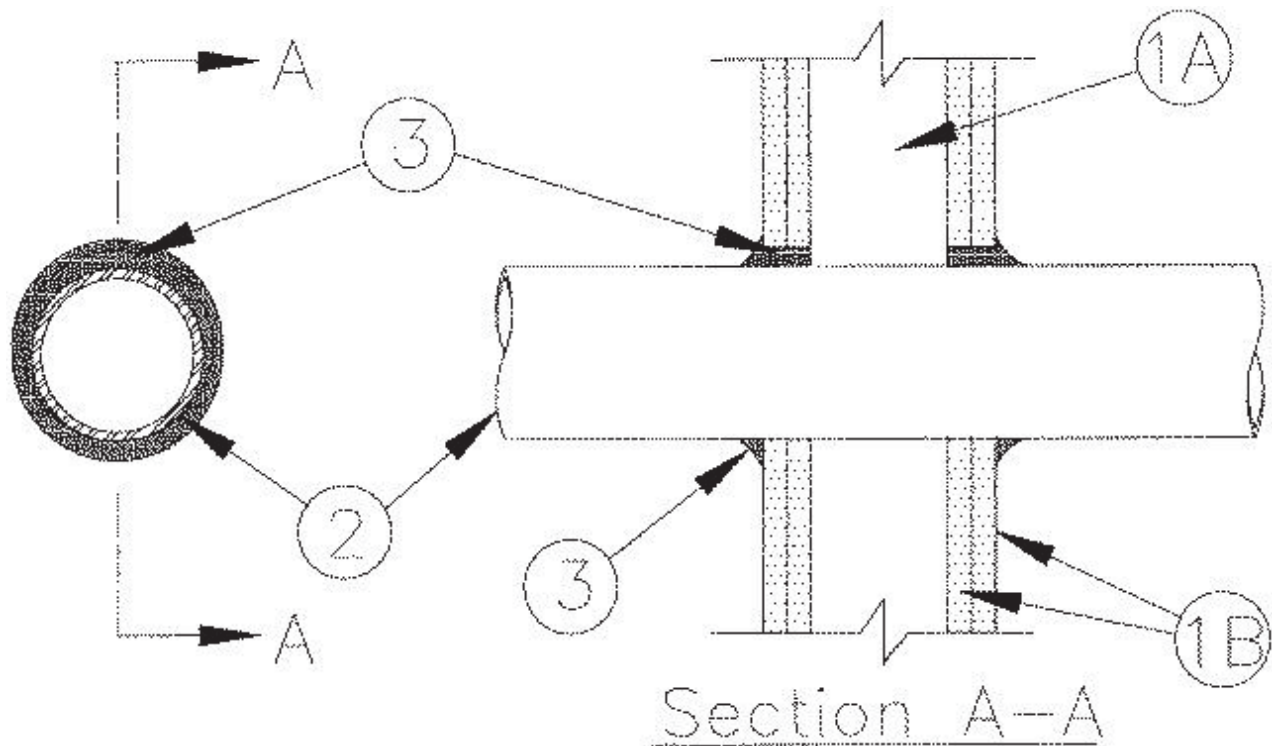

**1. Wall Assembly** — The 1 or 2 hr fire-rated gypsum wallboard/stud wall assembly shall be constructed of the materials and in the manner specified in the individual U300 or U400 Series Wall and Partition Designs in the UL Fire Resistance Directory and shall include the following construction features:

**A. Studs** — Wall framing may consist of either wood studs or steel channel studs. Wood studs to consist of nom 2 by 4 in. (51 by 102 mm) lumber spaced 16 in. (406 mm) OC. Steel studs to be min 2-1/2 in. (64 mm) wide and spaced max 24 in. (610 mm) OC.

**B. Gypsum Board\*** — 5/8 in. (16 mm) thick, 4 ft (122 cm) wide with square or tapered edges. The gypsum wallboard type, number of layers, fastener type and sheet orientation shall be as specified in the individual Wall and Partition Design. Max diam of opening is 13-1/4 in. (337 mm).

Diam of circular opening cut through gypsum wallboard on each side of wall assembly to be min 1/4 in. (6 mm) to max 1/2 in. (13 mm) larger than outside diam of through penetrant (Item 2).

**The hourly F and FH Ratings of the firestop system are equal to the hourly fire rating of the wall assembly in which it is installed.**

**2. Through Penetrants** — One metallic pipe, conduit or tubing to be installed either concentrically or eccentrically within the firestop system. Pipe, conduit or tubing to be rigidly supported on both sides of wall assembly. The annular space between the through-penetrant and the periphery of the opening shall be min 0 in. to max 1/4 in. (6 mm). The following types and sizes of metallic pipes, conduits or tubing may be used:

**A. Steel Pipe** — Nom 12 in. (305 mm) diam (or smaller) Schedule 10 (or heavier) steel pipe.

**B. Iron Pipe** — Nom 12 in. (305 mm) diam (or smaller) cast or ductile iron pipe.

**C. Conduit** — Nom 6 in. (152 mm) diam (or smaller) steel electrical metallic tubing or steel conduit.

**D. Copper Tubing** — Nom 6 in. (152 mm) diam (or smaller) Type L (or heavier) copper tubing.

**E. Copper Pipe** — Nom 6 in. (152 mm) diam (or smaller) Regular (or heavier) copper pipe.

**3. Fill, Void or Cavity Material\* — Sealant** — Fill material to be forced into the annulus to maximum extent possible. Additional fill material to be installed such that a min 1/2 in. (13 mm) crown is formed around the penetrating item and lapping 1/4 in. (6 mm) beyond the periphery of the opening.

**HILTI CONSTRUCTION CHEMICALS, DIV OF HILTI INC** — FS-One Sealant, FS-ONE MAX Intumescent Sealant

\* Indicates such products shall bear the UL or cUL Certification Mark for jurisdictions employing the UL or cUL Certification (such as Canada), respectively.

Last Updated on 2015-01-23

[Questions?](#)

[Print this page](#)

[Terms of Use](#)

[Page Top](#)



When the UL Leaf Mark is on the product, or when the word "Environment" is included in the UL Mark, please search the [UL Environment database](#) for additional information regarding this product's certification.

The appearance of a company's name or product in this database does not in itself assure that products so identified have been manufactured under UL's Follow-Up Service. Only those products bearing the UL Mark should be considered to be Certified and covered under UL's Follow-Up Service. Always look for the Mark on the product.

UL permits the reproduction of the material contained in the Online Certification Directory subject to the following conditions: 1. The Guide Information, Assemblies, Constructions, Designs, Systems, and/or Certifications (files) must be presented in their entirety and in a non-misleading manner, without any manipulation of the data (or drawings). 2. The statement "Reprinted from the Online Certifications Directory with permission from UL" must appear adjacent to the extracted material. In addition, the reprinted material must include a copyright notice in the following format: "© 2015 UL LLC".



## System No. W-L-1092 XHEZ.W-L-1092 Through-penetration Firestop Systems

[Page Bottom](#)

### Design/System/Construction/Assembly Usage Disclaimer

- Authorities Having Jurisdiction should be consulted in all cases as to the particular requirements covering the installation and use of UL Certified products, equipment, system, devices, and materials.
- Authorities Having Jurisdiction should be consulted before construction.
- Fire resistance assemblies and products are developed by the design submitter and have been investigated by UL for compliance with applicable requirements. The published information cannot always address every construction nuance encountered in the field.
- When field issues arise, it is recommended the first contact for assistance be the technical service staff provided by the product manufacturer noted for the design. Users of fire resistance assemblies are advised to consult the general Guide Information for each product category and each group of assemblies. The Guide Information includes specifics concerning alternate materials and alternate methods of construction.
- Only products which bear UL's Mark are considered Certified.

### XHEZ - Through-penetration Firestop Systems

### XHEZ7 - Through-penetration Firestop Systems Certified for Canada

[See General Information for Through-penetration Firestop Systems](#)

[See General Information for Through-penetration Firestop Systems Certified for Canada](#)

## System No. W-L-1092

January 23, 2015

ANSI/UL1479 (ASTM E814)	CAN/ULC S115
F Ratings — 1 & 2 Hr (See Item 1)	F Ratings — 1 & 2 Hr (See Item 1)
T Ratings — 0 & 1/4 Hr (See Item 1)	FT Ratings— 0 & 1/4 Hr (See Item 1)
	FH Ratings — 1 & 2 Hr (See Item 1)
	FTH Ratings — 0 & 1/4 Hr (See Item 1)

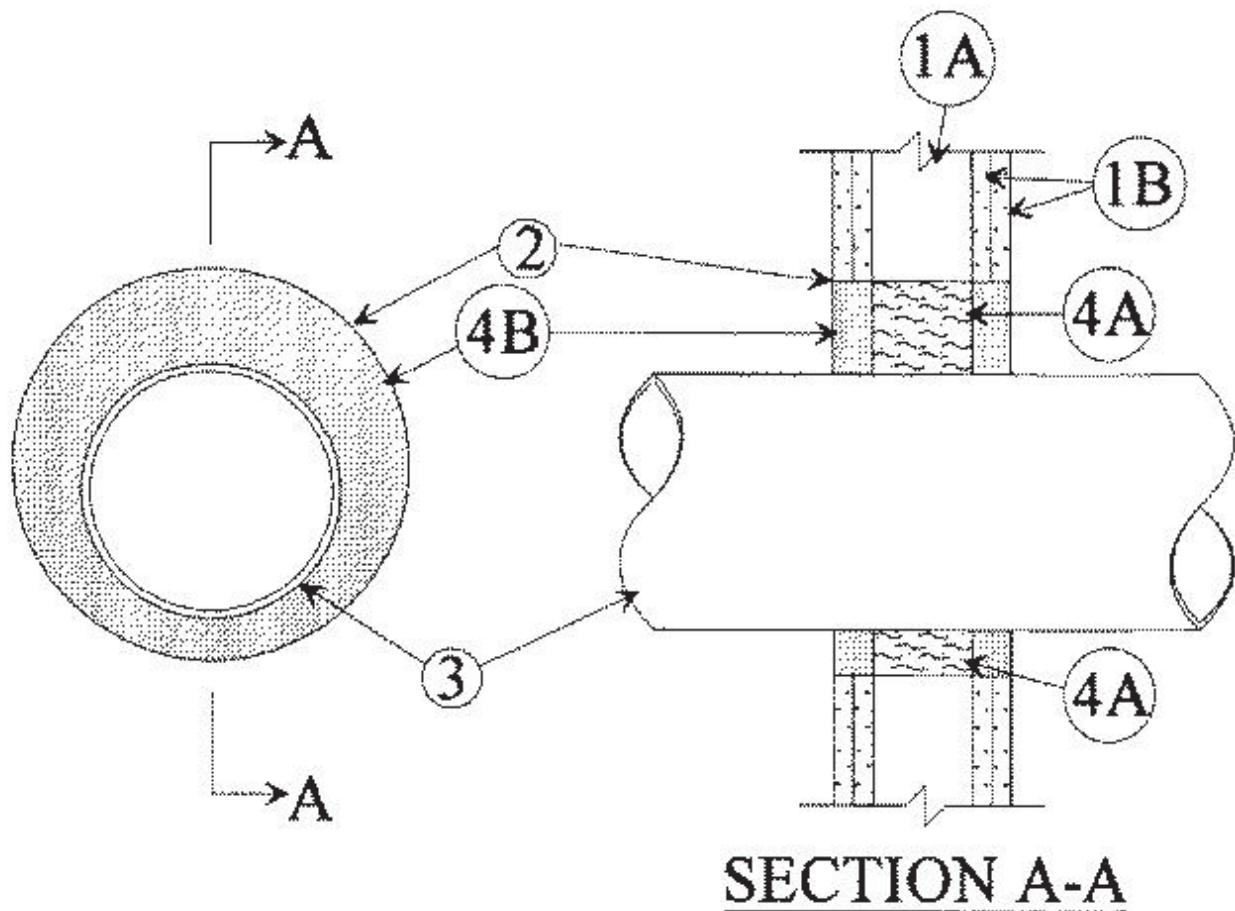

**1. Wall Assembly** — The 1 or 2 hr fire-rated gypsum wallboard/stud wall assembly shall be constructed of the materials and in the manner specified in the individual U300, U400 or V400 Series Wall and Partition Designs in the UL Fire Resistance Directory and shall include the following construction features:

**A. Studs** — Wall framing may consist of either wood studs or steel channel studs. Wood studs to consist of nom 2 by 4 in. (51 by 102 mm) lumber spaced 16 in. (406 mm) OC. Steel studs to be min 3-1/2 in. (89 mm) wide and spaced max 24 in. (610 mm) OC.

**B. Gypsum Board\*** — 5/8 in. (16 mm) thick, 4 ft wide with square or tapered edges. The gypsum wallboard type, thickness, number of layers, fastener type and sheet orientation shall be as specified in the individual Wall and Partition Design. Max diam of opening is 10 in. (254 mm).

**The hourly F, FH Ratings are equal to the hourly fire rating of the wall assembly. The hourly T, FT, FTH Ratings are 0 and 1/4 hr for 1 and 2 hr rated wall assemblies, respectively.**

**2. Steel Sleeve** — Max 10 in. (254 mm) diam cylindrical sleeve fabricated from min 0.016 in. thick (28 gauge) galv sheet steel and having a min 2 in. (51 mm) lap along the longitudinal seam. Length of steel sleeve to be equal to thickness of wall. Sleeve installed by coiling the sheet steel to a diam smaller than the through opening, inserting the coil through the openings and releasing the coil to let it uncoil against the circular cutouts in the gypsum wallboard layers. Sleeve may also be formed of No. 8 steel wire mesh having a min 1 in. (25 mm) lap along the longitudinal seam.

**3. Through Penetrants** — One metallic pipe or conduit or tubing to be installed either concentrically or eccentrically within the firestop system. Pipe or conduit to be rigidly supported on both sides of wall assembly. The annular space between pipe or conduit and periphery of opening shall be 1 in. to 2-3/8 in. (25 to 60 mm). The following types and sizes of metallic pipes or conduits may be used:

**A. Steel Pipe** — Nom 6 in. (152 mm) diam (or smaller) Schedule 10 (or heavier) steel pipe.

**B. Conduit** — Nom 4 in. (102 mm) diam (or smaller) steel electrical metallic tubing or conduit.

**C. Steel Pipe** — Nom 4 in. (102 mm) diam (or smaller) Schedule 7 (or heavier) steel pipe.

**4. Firestop System** — The firestop system shall consist of the following:

**A. Packing Material** — Min 1-1/4 in. or 2-1/2 in. (32 or 64 mm) thickness of mineral wool batt insulation for 1 and 2 hr assemblies, respectively, firmly packed into steel sleeve on both sides of the wall assembly as permanent forms. Packing material to be recessed from both surfaces of wall as required to accommodate the required thickness of fill material.

**B. Fill, Void or Cavity Material — Sealant\*** — Min 1-1/4 in. (32 mm) thickness applied within

steel sleeve, flush with both surfaces of wall.

**HILTI CONSTRUCTION CHEMICALS, DIV OF HILTI INC** — CFS-S SIL GG, FS-ONE Sealant or FS-ONE MAX Intumescent Sealant

**\* Indicates such products shall bear the UL or cUL Certification Mark for jurisdictions employing the UL or cUL Certification (such as Canada), respectively.**

Last Updated on 2015-01-23

---

[Questions?](#)

[Print this page](#)

[Terms of Use](#)

[Page Top](#)

© 2015 UL LLC

When the UL Leaf Mark is on the product, or when the word "Environment" is included in the UL Mark, please search the [UL Environment database](#) for additional information regarding this product's certification.

The appearance of a company's name or product in this database does not in itself assure that products so identified have been manufactured under UL's Follow-Up Service. Only those products bearing the UL Mark should be considered to be Certified and covered under UL's Follow-Up Service. Always look for the Mark on the product.

UL permits the reproduction of the material contained in the Online Certification Directory subject to the following conditions: 1. The Guide Information, Assemblies, Constructions, Designs, Systems, and/or Certifications (files) must be presented in their entirety and in a non-misleading manner, without any manipulation of the data (or drawings). 2. The statement "Reprinted from the Online Certifications Directory with permission from UL" must appear adjacent to the extracted material. In addition, the reprinted material must include a copyright notice in the following format: "© 2015 UL LLC".



## **System No. W-L-1175 XHEZ.W-L-1175 Through-penetration Firestop Systems**

[Page Bottom](#)

---

### **Design/System/Construction/Assembly Usage Disclaimer**

- Authorities Having Jurisdiction should be consulted in all cases as to the particular requirements covering the installation and use of UL Certified products, equipment, system, devices, and materials.
  - Authorities Having Jurisdiction should be consulted before construction.
  - Fire resistance assemblies and products are developed by the design submitter and have been investigated by UL for compliance with applicable requirements. The published information cannot always address every construction nuance encountered in the field.
  - When field issues arise, it is recommended the first contact for assistance be the technical service staff provided by the product manufacturer noted for the design. Users of fire resistance assemblies are advised to consult the general Guide Information for each product category and each group of assemblies. The Guide Information includes specifics concerning alternate materials and alternate methods of construction.
  - Only products which bear UL's Mark are considered Certified.
- 

### **XHEZ - Through-penetration Firestop Systems**

[See General Information for Through-penetration Firestop Systems](#)

#### **System No. W-L-1175**

February 08, 2006

**F Ratings — 1 and 2 Hr (See Item 1)**

**T Rating — 0 Hr**

**L Rating at Ambient — Less Than 1 CFM/sq ft**

**L Rating at 400 F — Less Than 1 CFM/sq ft**

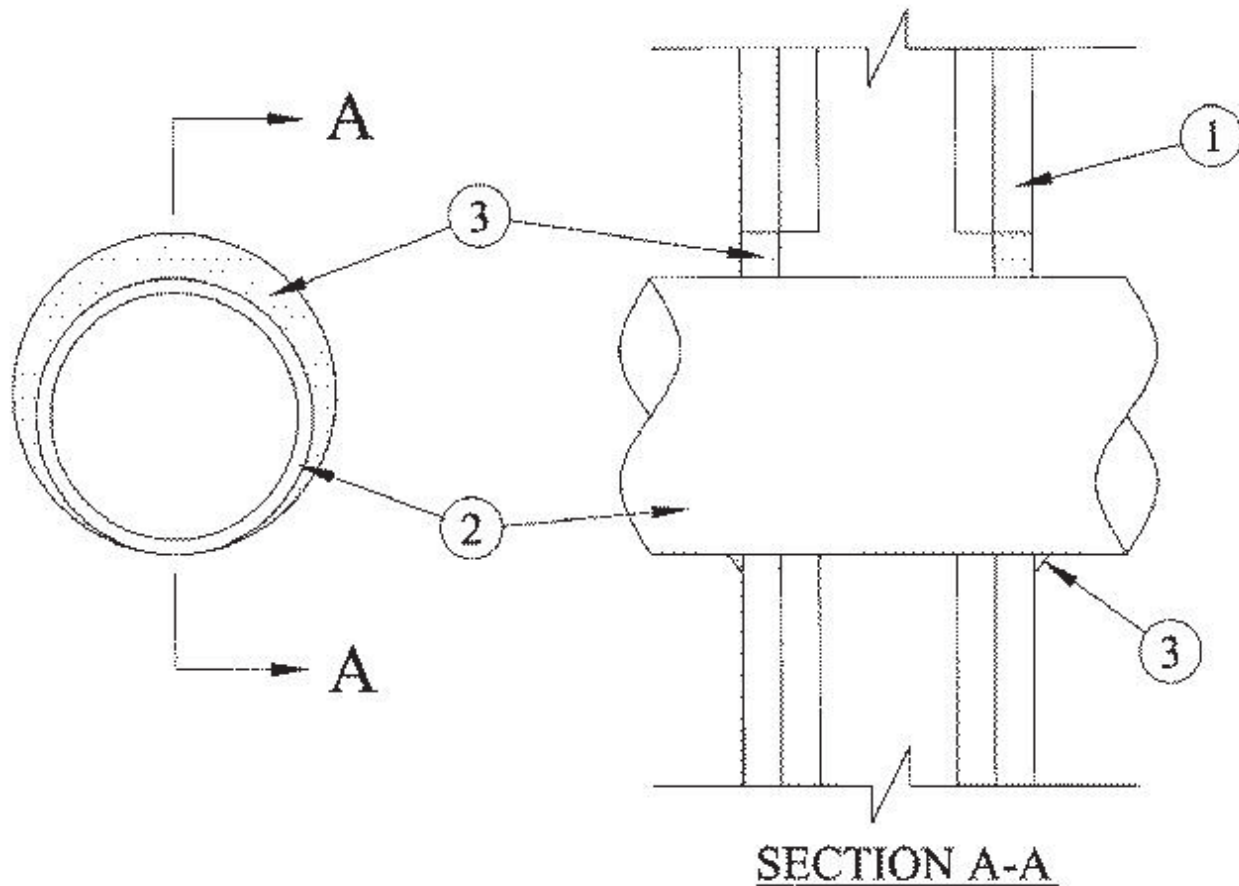

1. **Wall Assembly** — The 1 or 2 hr fire rated wallboard/stud wall assembly shall be constructed of the materials and in the manner specified in the individual U300 or U400 Series Wall and Partition Designs in the UL Fire Resistance Directory and shall include the following construction features.

A. **Studs** — Wall framing shall consist of either wood studs or steel channel studs. Wood studs to consist of nom 2 by 4 in. lumber spaced 16 in. OC. Steel studs to be min 2-1/2 in. wide and spaced max 24 in. OC.

B. **Gypsum Board\*** — Nom 5/8 in. thick, 4 ft wide with square or tapered edges. The gypsum wallboard type, thickness, number of layers, fastener type and sheet orientation shall be as specified in the individual U300 or U400 Series Design in the Fire Resistance Directory. Max diam of opening is 5-1/2 in.

**The hourly F and T Ratings of the firestop system is equal to the hourly fire rating of the wall assembly in which it is installed.**

2. **Through Penetrant** — One metallic tubing or conduit installed concentrically or eccentrically within the firestop system. Tube or conduit to be rigidly supported on both sides of wall assembly. The annular space between the tube or conduit and periphery of the steel sleeve shall be min 0 in. (point contact) to max 1 in. The following types and sizes of metallic tube or conduit may be used:

A. **Conduit** — Nom 4 in. diam (or smaller) steel electrical metallic tubing or steel conduit.

3. **Fill Void or Cavity Material\* — Putty** — Min 5/8 in. thickness of fill material applied within the annulus, flush with both surfaces of wall. At point contact location between penetrant and wall, a 1/4 in. crown of fill material shall be applied at the conduit/wall interface on both sides of the assembly, lapping 1/4 in. on the conduit and 1/4 in. beyond the periphery of the opening.

**HILTI INC** — CP618 Putty Stick

**\* Indicates such products shall bear the UL or cUL Certification Mark for jurisdictions employing the UL or cUL Certification (such as Canada), respectively.**

Last Updated on 2006-02-08

[Questions?](#)

[Print this page](#)

[Terms of Use](#)

[Page Top](#)

© 2015 UL LLC

When the UL Leaf Mark is on the product, or when the word "Environment" is included in the UL Mark, please search the [UL Environment](#)

[database](#) for additional information regarding this product's certification.

The appearance of a company's name or product in this database does not in itself assure that products so identified have been manufactured under UL's Follow-Up Service. Only those products bearing the UL Mark should be considered to be Certified and covered under UL's Follow-Up Service. Always look for the Mark on the product.

UL permits the reproduction of the material contained in the Online Certification Directory subject to the following conditions: 1. The Guide Information, Assemblies, Constructions, Designs, Systems, and/or Certifications (files) must be presented in their entirety and in a non-misleading manner, without any manipulation of the data (or drawings). 2. The statement "Reprinted from the Online Certifications Directory with permission from UL" must appear adjacent to the extracted material. In addition, the reprinted material must include a copyright notice in the following format: "© 2015 UL LLC".



## System No. W-L-1214 XHEZ.W-L-1214 Through-penetration Firestop Systems

[Page Bottom](#)

### Design/System/Construction/Assembly Usage Disclaimer

- Authorities Having Jurisdiction should be consulted in all cases as to the particular requirements covering the installation and use of UL Certified products, equipment, system, devices, and materials.
- Authorities Having Jurisdiction should be consulted before construction.
- Fire resistance assemblies and products are developed by the design submitter and have been investigated by UL for compliance with applicable requirements. The published information cannot always address every construction nuance encountered in the field.
- When field issues arise, it is recommended the first contact for assistance be the technical service staff provided by the product manufacturer noted for the design. Users of fire resistance assemblies are advised to consult the general Guide Information for each product category and each group of assemblies. The Guide Information includes specifics concerning alternate materials and alternate methods of construction.
- Only products which bear UL's Mark are considered Certified.

### XHEZ - Through-penetration Firestop Systems

### XHEZ7 - Through-penetration Firestop Systems Certified for Canada

[See General Information for Through-penetration Firestop Systems](#)

[See General Information for Through-penetration Firestop Systems Certified for Canada](#)

### System No. W-L-1214

January 22, 2015

ANSI/UL1479 (ASTM E814)	CAN/ULC S115
F Rating — 1 Hr	F Rating —1 Hr
T Rating — 0 Hr	FT Rating — 0 Hr
	FH Rating — 1 Hr
	FTH Rating — 0 Hr



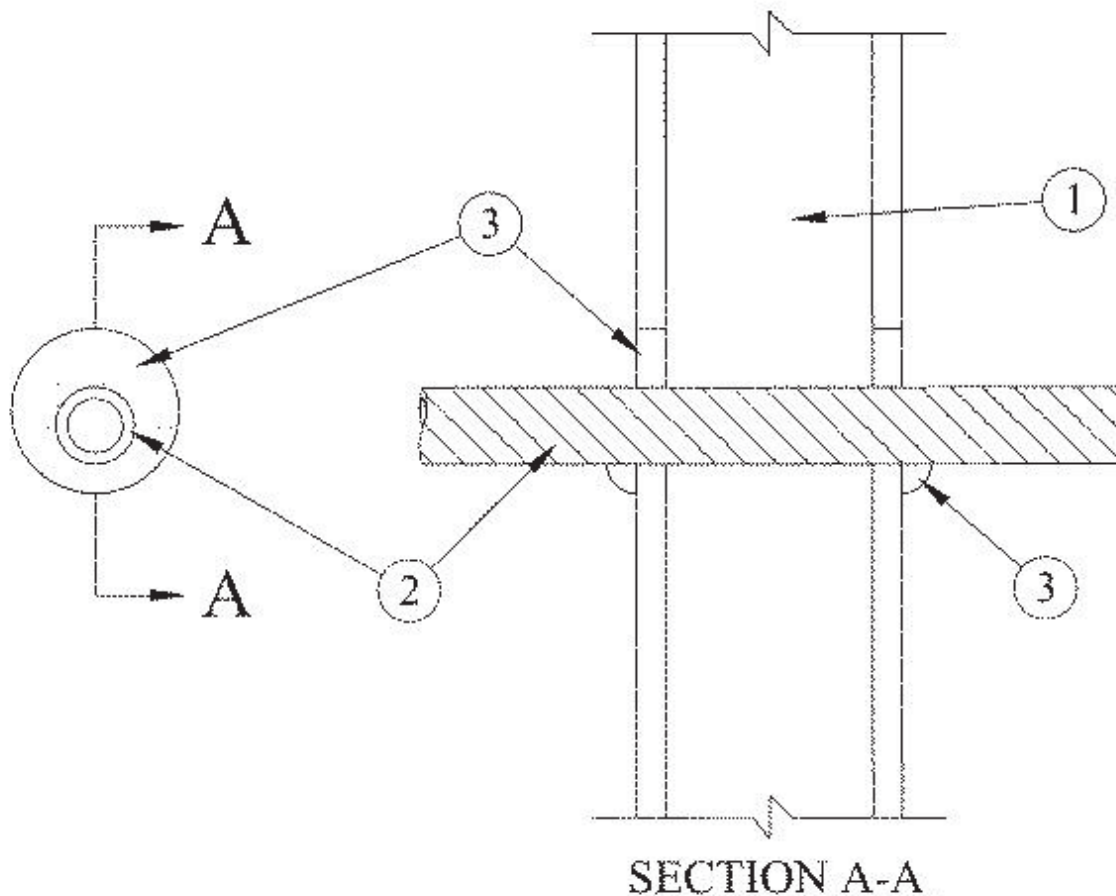

1. **Wall Assembly** — The fire-rated gypsum wallboard/stud wall assembly shall be constructed of the materials and in the manner specified if the individual U300, U400, V400 or W400 Series Wall and Partition Designs in the Fire Resistance Directory and shall include the following construction features:

A. **Studs** — Wall framing shall consist of either wood studs or channel shaped steel studs. Wood studs to consist of 2 by 4 in. (51 by 102 mm) lumber spaced 16 in. (406 mm) OC. Steel studs to be min 2-1/2 in. (64 mm) wide, fabricated from min 25 MSG galvanized steel, spaced max 24 in. (610 mm) OC.

B. **Wallboard, Gypsum\*** — One layer of nom 5/8 in. (16 mm) gypsum wallboard, as specified in the individual Wall and Partition Design. Max diam of opening is 2 in. (51 mm).

2. **Through Penetrants — Flexible Steel Conduit+** — Nom 1 in. (25 mm) diam (or smaller) flexible steel conduit. Max one conduit to be installed either concentrically or eccentrically within the firestop system. The annular space between pipe and periphery of opening shall be min 0 in. (0 mm, point contact) to max 3/4 in. (19 mm). Conduit to be rigidly supported on both sides of floor or wall assembly.

See **Flexible Metal Conduit** (DXUZ) category in the Electrical Construction Materials Directory for names of manufacturers.

3. **Fill, Void or Cavity Material\* — Sealant** — Min 5/8 in. (16 mm) thickness of fill material applied within annulus flush with both surfaces of wall. At point contact location between conduit and wall, a min 1/2 in. (13 mm) bead of fill material shall be applied at the conduit/wallboard interface on both side of wall.

**HILTI CONSTRUCTION CHEMICALS, DIV OF HILTI INC** — FS-ONE Sealant or FS-ONE MAX Intumescent Sealant

+Bearing the UL Listing Mark

\* Indicates such products shall bear the UL or cUL Certification Mark for jurisdictions employing the UL or cUL Certification (such as Canada), respectively.

Last Updated on 2015-01-22

[Questions?](#)

[Print this page](#)

[Terms of Use](#)

[Page Top](#)

© 2015 UL LLC

When the UL Leaf Mark is on the product, or when the word "Environment" is included in the UL Mark, please search the [UL Environment database](#) for additional information regarding this product's certification.

The appearance of a company's name or product in this database does not in itself assure that products so identified have been manufactured under UL's Follow-Up Service. Only those products bearing the UL Mark should be considered to be Certified and covered under UL's Follow-Up Service. Always look for the Mark on the product.

UL permits the reproduction of the material contained in the Online Certification Directory subject to the following conditions: 1. The Guide Information, Assemblies, Constructions, Designs, Systems, and/or Certifications (files) must be presented in their entirety and in a non-misleading manner, without any manipulation of the data (or drawings). 2. The statement "Reprinted from the Online Certifications Directory with permission from UL" must appear adjacent to the extracted material. In addition, the reprinted material must include a copyright notice in the following format: "© 2015 UL LLC".



## System No. W-L-1247 XHEZ.W-L-1247 Through-penetration Firestop Systems

[Page Bottom](#)

### Design/System/Construction/Assembly Usage Disclaimer

- Authorities Having Jurisdiction should be consulted in all cases as to the particular requirements covering the installation and use of UL Certified products, equipment, system, devices, and materials.
- Authorities Having Jurisdiction should be consulted before construction.
- Fire resistance assemblies and products are developed by the design submitter and have been investigated by UL for compliance with applicable requirements. The published information cannot always address every construction nuance encountered in the field.
- When field issues arise, it is recommended the first contact for assistance be the technical service staff provided by the product manufacturer noted for the design. Users of fire resistance assemblies are advised to consult the general Guide Information for each product category and each group of assemblies. The Guide Information includes specifics concerning alternate materials and alternate methods of construction.
- Only products which bear UL's Mark are considered Certified.

### XHEZ - Through-penetration Firestop Systems

[See General Information for Through-penetration Firestop Systems](#)

#### System No. W-L-1247

May 22, 2001

**F Rating — 2 Hr**

**T Rating — 0 Hr**

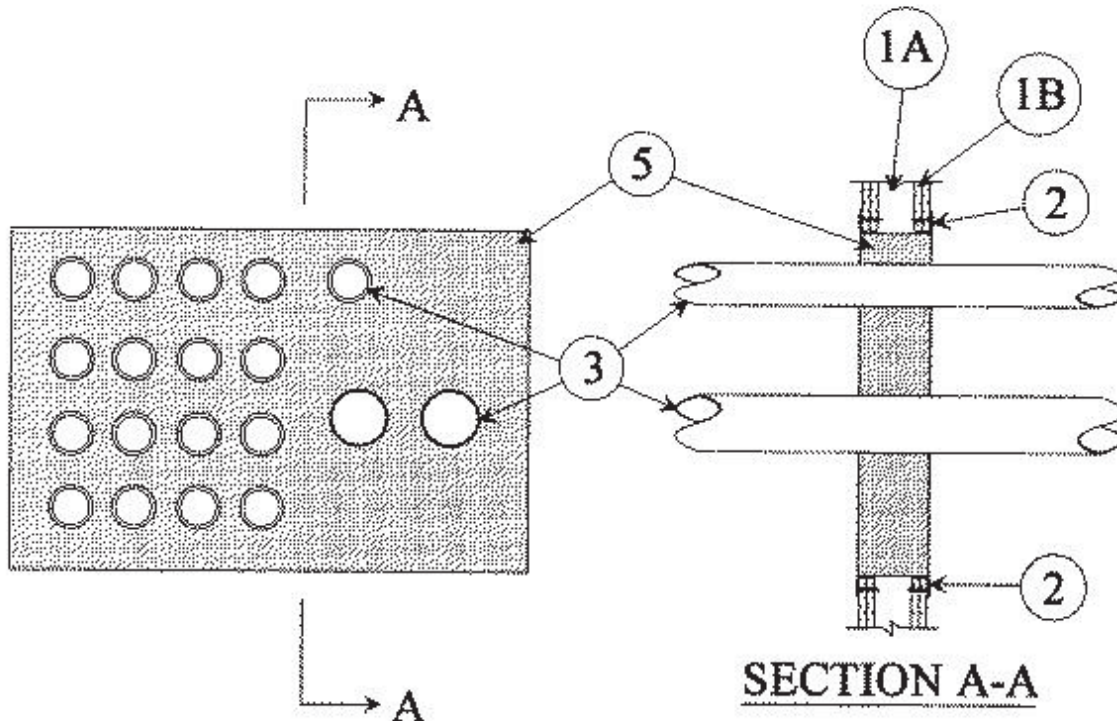

**1. Wall Assembly** — The fire-rated gypsum wallboard/stud wall assembly shall be constructed of the materials and in the manner specified in the individual U300 or U400 Series Wall and Partition Designs in the UL Fire Resistance Directory and shall include the following construction features:

A. **Studs** — Wall framing may consist of either wood studs or steel channel studs. Wood studs to consist of nom 2 by 4 in. lumber spaced 16 in. OC. Steel studs to be min 2-1/2 in. wide and spaced max 24 in. OC. Additional framing members to be installed in stud cavity containing the through penetrating item to form a rectangular box around the penetrants.

B. **Gypsum Board\*** — Two layers of nom 5/8 in. thick gypsum wallboard, as specified in the individual Wall and Partition Design. Max area of opening is 1024 sq in. with max dimension of 32 in. for steel stud walls. Max width of opening in wood stud walls is limited to 14-1/2 in.

2. **Angle Clips** — Nom 1-1/2 in. by 1-1/2 in. by No. 22 gauge (or heavier) steel angles attached to all four sides of the opening on both sides of the wall. The angle shall be attached to the wall with min 1-5/8 in. long Type S self-drilling, self-tapping bugle-head steel screws spaced max of 2 in. from each end and at a max of 5 in. OC.

3. **Through Penetrants** — The space between pipes, conduits or tubing shall be min 1 in. when diam of through penetrant is 1-1/2 in. or smaller and 2-1/2 in. when diam of through penetrant is larger than 1-1/2 in. The space between pipes, conduits or tubing and periphery of opening shall be min 1 in. when diam of through penetrant is 1-1/2 in. or smaller and 2-1/2 in. when diam of through penetrant is larger than 1-1/2 in. Pipe, conduit or tubing to be rigidly supported on both sides of wall assembly. The following types and sizes of metallic pipes, conduits or tubing may be used:

A. **Steel Pipe** — Nom 6 in. diam (or smaller) Schedule 10 (or heavier) steel pipe.

B. **Iron Pipe** — Nom 6 in. diam (or smaller) cast or ductile iron pipe.

C. **Conduit** — Nom 6 in. diam (or smaller) steel conduit or nom 4 in. diam (or smaller) steel electrical metallic tubing.

D. **Copper Tubing** — Nom 3 in. diam (or smaller) Type L (or heavier) copper tubing.

E. **Copper Pipe** — Nom 3 in. diam (or smaller) Regular (or heavier) copper pipe.

4. **Forms** — (Not Shown) — Used as a form to prevent leakage of fill material during installation. Forms to be a rigid sheet material, cut to fit the contour of the penetrating items and fastened to both sides of wall. Forms to be removed after fill material has cured.

5. **Fill, Void or Cavity Material\*—Mortar** — Min 4-1/2 in. thickness of fill material applied within the annulus, centered within the wall. Mortar is mixed at a rate of 2-1/2 parts dry mix to one part water by volume in accordance with the fill material manufacturer's installation instructions.

**HILTI CONSTRUCTION CHEMICALS, DIV OF HILTI INC** — CP637 Mortar

**\* Indicates such products shall bear the UL or cUL Certification Mark for jurisdictions employing the UL or cUL Certification (such as Canada), respectively.**

Last Updated on 2001-05-22

[Questions?](#)

[Print this page](#)

[Terms of Use](#)

[Page Top](#)

© 2015 UL LLC

When the UL Leaf Mark is on the product, or when the word "Environment" is included in the UL Mark, please search the [UL Environment database](#) for additional information regarding this product's certification.

The appearance of a company's name or product in this database does not in itself assure that products so identified have been manufactured under UL's Follow-Up Service. Only those products bearing the UL Mark should be considered to be Certified and covered under UL's Follow-Up Service. Always look for the Mark on the product.

UL permits the reproduction of the material contained in the Online Certification Directory subject to the following conditions: 1. The Guide Information, Assemblies, Constructions, Designs, Systems, and/or Certifications (files) must be presented in their entirety and in a non-misleading manner, without any manipulation of the data (or drawings). 2. The statement "Reprinted from the Online Certifications Directory with permission from UL" must appear adjacent to the extracted material. In addition, the reprinted material must include a copyright notice in the following format: "© 2015 UL LLC".



## System No. W-L-1249 XHEZ.W-L-1249 Through-penetration Firestop Systems

[Page Bottom](#)

### Design/System/Construction/Assembly Usage Disclaimer

- Authorities Having Jurisdiction should be consulted in all cases as to the particular requirements covering the installation and use of UL Certified products, equipment, system, devices, and materials.
- Authorities Having Jurisdiction should be consulted before construction.
- Fire resistance assemblies and products are developed by the design submitter and have been investigated by UL for compliance with applicable requirements. The published information cannot always address every construction nuance encountered in the field.
- When field issues arise, it is recommended the first contact for assistance be the technical service staff provided by the product manufacturer noted for the design. Users of fire resistance assemblies are advised to consult the general Guide Information for each product category and each group of assemblies. The Guide Information includes specifics concerning alternate materials and alternate methods of construction.
- Only products which bear UL's Mark are considered Certified.

### XHEZ - Through-penetration Firestop Systems

[See General Information for Through-penetration Firestop Systems](#)

#### System No. W-L-1249

December 07, 2001

**F Ratings — 1 and 2 Hr (See Items 1 and 3)**

**T Rating — 1/2 Hr**

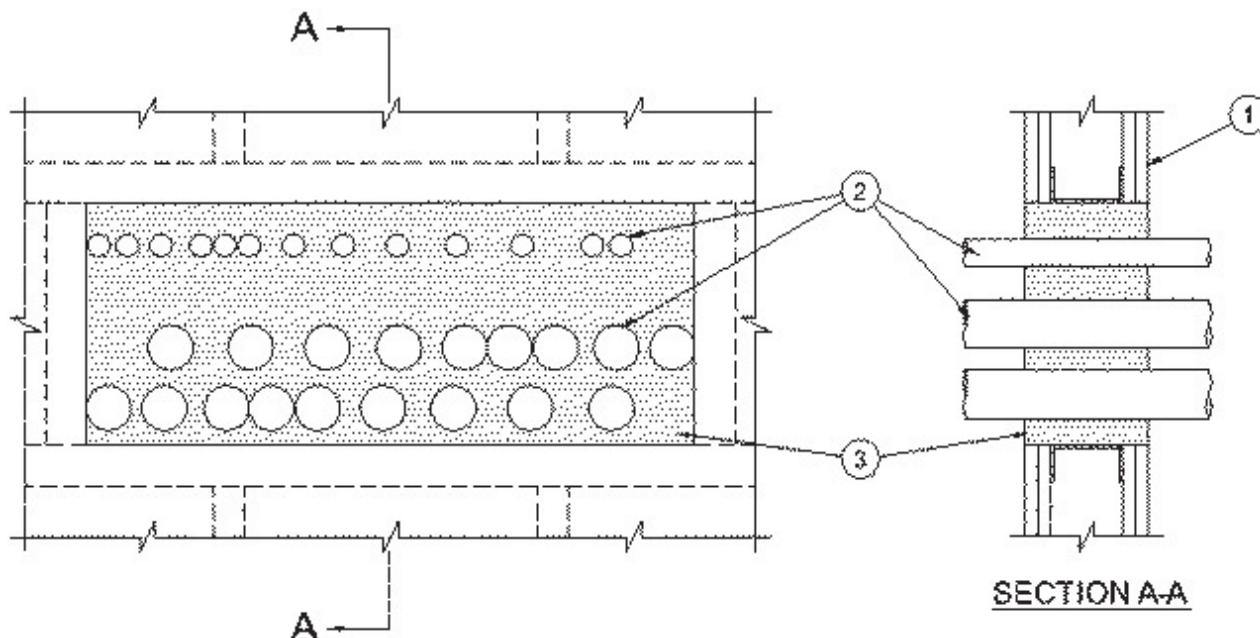

**1. Wall Assembly** — The 1 or 2 hr fire-rated gypsum board/stud wall assembly shall be constructed of the materials and in the manner described in the individual U400 Series Wall or Partition Design in the UL Fire Resistance Directory and shall include the following construction features.

**A. Studs** — Steel studs 3-1/2 in. deep, fabricated from 25 MSG galv steel, spaced max 24 in. OC.

**B. Gypsum Boards\*** — The gypsum board type, number of layers, fastener type and sheet orientation shall be as specified in the individual Wall and Partition Design. Max area of opening is 360 sq in. with max dimension of 30 in.

**The hourly F Rating of the firestop system is equal to the hourly fire rating of the wall assembly in which it is installed.**

2. **Through Penetrants** — One or more nom 2 in. diam (or smaller) rigid steel conduit or electrical metallic tubing (EMT) to be installed within the opening. The annular space between conduits or tubing shall be min 0 in. (point contact) to max 3-3/8 in. The annular space between conduits or tubing and periphery of opening shall be min 0 in. (point contact) to max 3 in. Conduit or tubing to be rigidly supported on both sides of wall assembly.

3. **Fill Void or Cavity Material - Foam\*** — Fill material applied within annulus flush with both surfaces of the wall. Min fill material thickness for 1 Hr F Rating is 4-3/4 in. Min fill material thickness for 2 Hr F Rating is 6 in.

**HILTI CONSTRUCTION CHEMICALS, DIV OF HILTI INC** — CP 620 Fire Foam

**\* Indicates such products shall bear the UL or cUL Certification Mark for jurisdictions employing the UL or cUL Certification (such as Canada), respectively.**

Last Updated on 2001-12-07

[Questions?](#)

[Print this page](#)

[Terms of Use](#)

[Page Top](#)

© 2015 UL LLC

When the UL Leaf Mark is on the product, or when the word "Environment" is included in the UL Mark, please search the [UL Environment database](#) for additional information regarding this product's certification.

The appearance of a company's name or product in this database does not in itself assure that products so identified have been manufactured under UL's Follow-Up Service. Only those products bearing the UL Mark should be considered to be Certified and covered under UL's Follow-Up Service. Always look for the Mark on the product.

UL permits the reproduction of the material contained in the Online Certification Directory subject to the following conditions: 1. The Guide Information, Assemblies, Constructions, Designs, Systems, and/or Certifications (files) must be presented in their entirety and in a non-misleading manner, without any manipulation of the data (or drawings). 2. The statement "Reprinted from the Online Certifications Directory with permission from UL" must appear adjacent to the extracted material. In addition, the reprinted material must include a copyright notice in the following format: "© 2015 UL LLC".



## System No. W-L-2078 XHEZ.W-L-2078 Through-penetration Firestop Systems

[Page Bottom](#)

### Design/System/Construction/Assembly Usage Disclaimer

- Authorities Having Jurisdiction should be consulted in all cases as to the particular requirements covering the installation and use of UL Certified products, equipment, system, devices, and materials.
- Authorities Having Jurisdiction should be consulted before construction.
- Fire resistance assemblies and products are developed by the design submitter and have been investigated by UL for compliance with applicable requirements. The published information cannot always address every construction nuance encountered in the field.
- When field issues arise, it is recommended the first contact for assistance be the technical service staff provided by the product manufacturer noted for the design. Users of fire resistance assemblies are advised to consult the general Guide Information for each product category and each group of assemblies. The Guide Information includes specifics concerning alternate materials and alternate methods of construction.
- Only products which bear UL's Mark are considered Certified.

### XHEZ - Through-penetration Firestop Systems

[See General Information for Through-penetration Firestop Systems](#)

#### System No. W-L-2078

January 28, 2015

**F Ratings — 1 and 2 Hr (See Item 1)**

**T Ratings — 0, 1 and 2 Hr (See Items 2 and 3)**

**L Rating At Ambient — 3 CFM/sq ft**

**L Rating At 400 F — Less Than 1 CFM/sq ft**

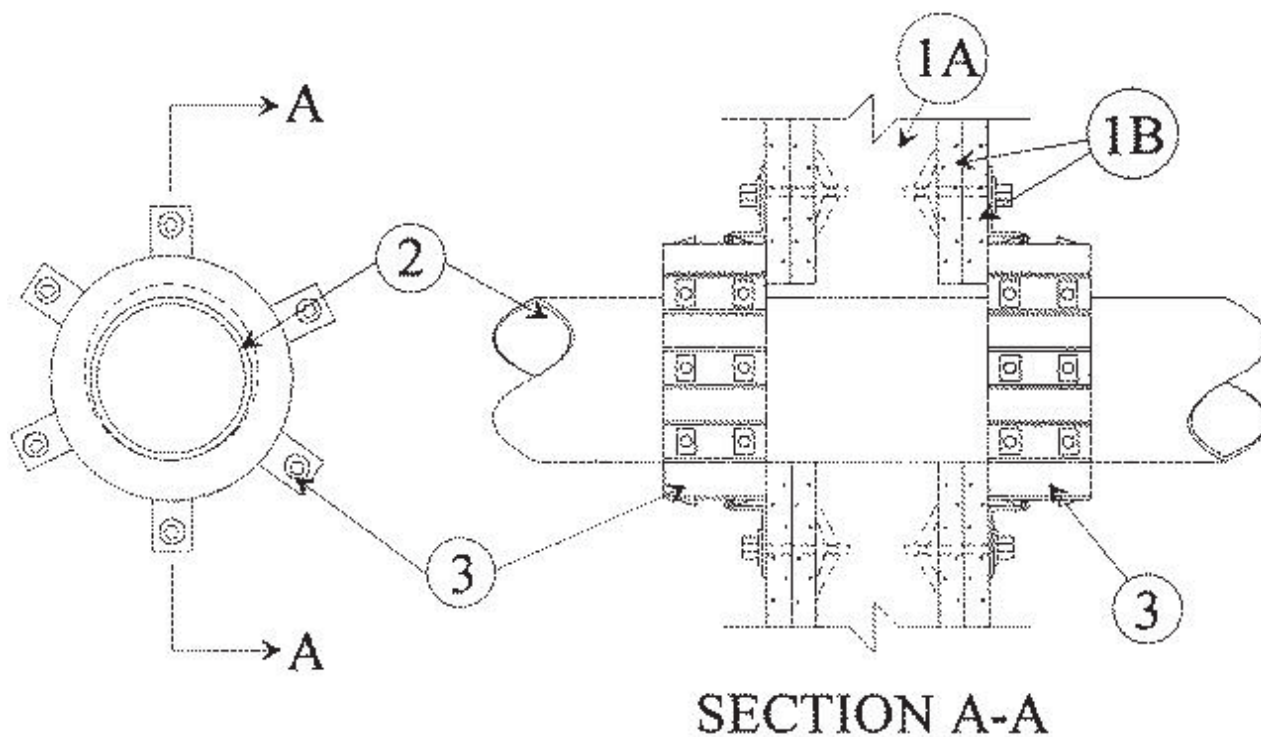

**1. Wall Assembly** — The fire-rated gypsum board/stud wall assembly shall be constructed of the materials and in the manner specified in the individual U300, U400, V400 or W400 Series Wall and Partition Designs in the UL fire Resistance

Directory and shall include the construction features noted below:

A. **Studs** — Wall framing may consist of either wood studs or steel channel studs. Wood studs to consist of nom 2 by 4 in. (51 by 102 mm) lumber spaced max 16 in. (406 mm) OC. Steel studs to be min 2-1/2 in. (64 mm) wide and spaced max 24 in. (610 mm) OC.

B. **Gypsum Board\*** — Nom 5/8 in. (16 mm) thick gypsum board, as specified in the individual Wall and Partition Design. Max diam of opening is 11-1/2 in. (292 mm).

**The hourly F Rating of the firestop system is equal to the hourly fire rating of the wall assembly in which it is installed.**

2. **Through-Penetrants** — One nonmetallic pipe, conduit or tubing to be installed within the firestop system. The annular space between pipe and periphery of opening shall be min 0 in. (point contact) to max 1/2 in. (13 mm). Pipe or conduit to be rigidly supported on both sides of the wall assembly. The following types and sizes of nonmetallic pipes may be used:

A. **Polyvinyl Chloride (PVC) Pipe** — Nom 10 in. (254 mm) diam (or smaller) Schedule 40 solid-core or cellular core PVC pipe for use in closed (process or supply) or vented (drain, waste or vent) piping system.

B. **Chlorinated Polyvinyl Chloride (CPVC) Pipe** — Nom 10 in. (254 mm) diam (or smaller) SDR13.5 CPVC pipe for use in closed (process or supply) piping systems.

C. **Acrylonitrile Butadiene Styrene (ABS) Pipe** — Nom 6 in. (152 mm) diam (or smaller) Schedule 40 solid-core or cellular core ABS pipe for use in closed (process or supply) or vented (drain, waste or vent) piping systems

D. **Flame Retardant Polypropylene (FRPP) Pipe** — Nom 6 in. (152 mm) diam (or smaller) Schedule 40 FRPP pipe for use in closed (process or supply) or vented (drain, waste or vent) piping system.

E. **Polyvinylidene Fluoride (PVDF) Pipe** — Nom 4 in. (102 mm) diam (or smaller) PVDF pipe for use in closed (process or supply) or vented (drain, waste or vent) piping system.

**When max 6 in. diam pipe is used, T Rating is equal to the hourly fire rating of the wall. When nom 8 in. or 10 in. (203 or 254 mm) diam pipe is used, T Rating is 0 hr.**

3. **Firestop Device\* — Firestop Collar** — Firestop collar shall be installed in accordance with the accompanying installation instructions. Collar to be installed and latched around the pipe and secured to both sides of the wall using the anchor hooks provided with the collar. (Minimum two anchor hooks for 1-1/2 and 2 in. (38 and 51 mm) diam pipes, three anchor hooks for 3 and 4 in. (76 and 102 mm) diam pipes, four anchor hooks for 6 in. (152 mm) diam pipes, ten anchor hooks for 8 in. (203 mm) diam pipes and twelve anchor hooks for 10 in. (254 mm) diam pipes. The anchor hooks are to be secured to the surface of wall with 3/16 in. (4.8 mm) diam by 2-1/2 in. (64 mm) long steel toggle bolts along with washers. As an alternate for pipe sizes of nom 4 in. diam or less, min No. 10 by 1-1/2 in. (254 by 38 mm) long drywall or laminate screws with min 3/4 in. (19 mm) steel washers may be used. **When the drywall or laminate screw is used, T Rating shall not exceed 1 hr.**

**HILTI CONSTRUCTION CHEMICALS, DIV OF HILTI INC** — CP 643 50/1.5"N, CP 643 63/2"N, CP 643 90/3"N, CP 643 110/4"N, CP 643 160/6"N, CP 644 200/8" and CP 644 250/10" Firestop Collars

4. **Fill, Void or Cavity Material\* — Sealant - (Not Shown)** — Min 1/2 in. (13 mm) thickness of sealant applied within the annular space for nom 8 in. and 10 in. (203 and 254 mm) diam pipes, flush with each side of wall. Sealant in annular space is optional for max 6 in. (152 mm) diam pipes. A min 1/4 in. (6 mm) thickness of sealant is required within the annular space, flush with each side of wall, to attain the L Ratings for max 6 in. (152 mm) diam pipes.

**HILTI CONSTRUCTION CHEMICALS, DIV OF HILTI INC** — FS-One Sealant or FS-ONE MAX Intumescent Sealant

**\* Indicates such products shall bear the UL or cUL Certification Mark for jurisdictions employing the UL or cUL Certification (such as Canada), respectively.**

Last Updated on 2015-01-28

[Questions?](#)

[Print this page](#)

[Terms of Use](#)

[Page Top](#)

© 2015 UL LLC

When the UL Leaf Mark is on the product, or when the word "Environment" is included in the UL Mark, please search the [UL Environment database](#) for additional information regarding this product's certification.

The appearance of a company's name or product in this database does not in itself assure that products so identified have been manufactured under UL's Follow-Up Service. Only those products bearing the UL Mark should be considered to be Certified and covered under UL's Follow-Up Service. Always look for the Mark on the product.

UL permits the reproduction of the material contained in the Online Certification Directory subject to the following conditions: 1. The Guide Information, Assemblies, Constructions, Designs, Systems, and/or Certifications (files) must be presented in their entirety and in a non-misleading manner, without any manipulation of the data (or drawings). 2. The statement "Reprinted from the Online Certifications Directory with permission from UL" must appear adjacent to the extracted material. In addition, the reprinted material must include a copyright notice in the following format: "© 2015 UL LLC".







## System No. W-L-3112 XHEZ.W-L-3112 Through-penetration Firestop Systems

[Page Bottom](#)

### Design/System/Construction/Assembly Usage Disclaimer

- Authorities Having Jurisdiction should be consulted in all cases as to the particular requirements covering the installation and use of UL Certified products, equipment, system, devices, and materials.
- Authorities Having Jurisdiction should be consulted before construction.
- Fire resistance assemblies and products are developed by the design submitter and have been investigated by UL for compliance with applicable requirements. The published information cannot always address every construction nuance encountered in the field.
- When field issues arise, it is recommended the first contact for assistance be the technical service staff provided by the product manufacturer noted for the design. Users of fire resistance assemblies are advised to consult the general Guide Information for each product category and each group of assemblies. The Guide Information includes specifics concerning alternate materials and alternate methods of construction.
- Only products which bear UL's Mark are considered Certified.

### XHEZ - Through-penetration Firestop Systems

### XHEZ7 - Through-penetration Firestop Systems Certified for Canada

[See General Information for Through-penetration Firestop Systems](#)

[See General Information for Through-penetration Firestop Systems Certified for Canada](#)

### System No. W-L-3112

January 26, 2015

ANSI/UL1479 (ASTM E814)	CAN/ULC S115
F Rating — 1 and 2 Hr (See Item 1)	F Rating — 1 and 2 Hr (See Item 1)
T Rating — 0 Hr	FT Rating — 0 Hr
	FH Rating — 1 and 2 Hr (See Item 1)
	FTH Rating — 0 Hr

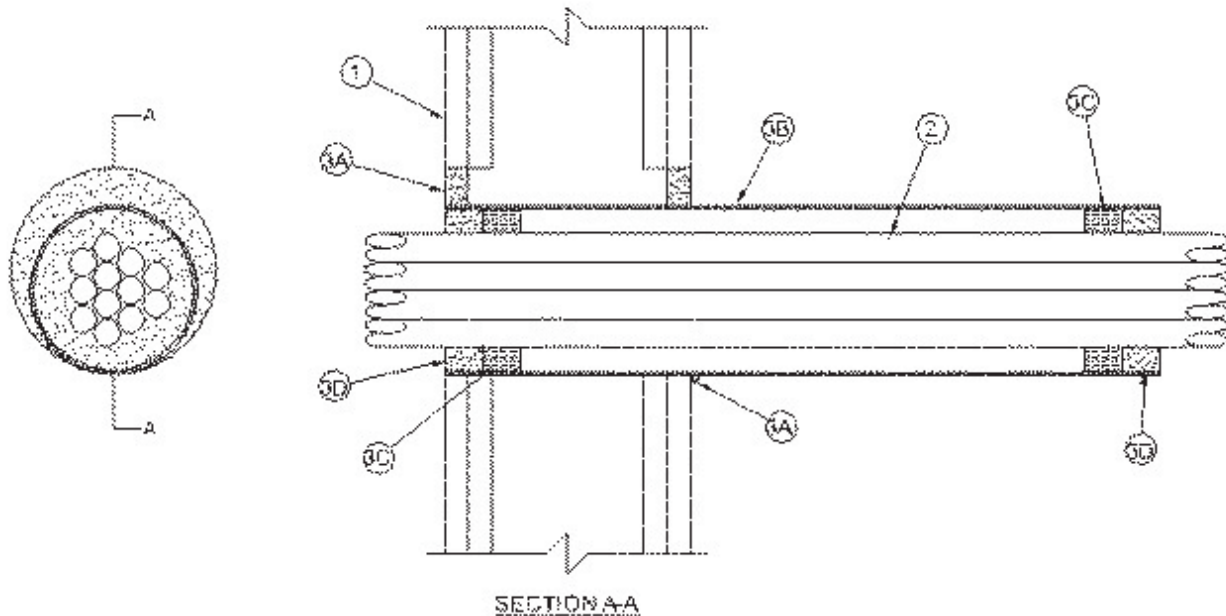

1. **Wall Assembly** — The 1 or 2 hr fire rated gypsum board/stud wall assembly shall be constructed of the materials

and in the manner specified in the individual U300, U400, V400 or W400 Series Wall and Partition Designs in the UL Fire Resistance Directory and shall include the following construction features:

A. **Studs** — Wall framing may consist of either wood studs or steel channel studs. Wood studs to consist of nom 2 by 4 in. (51 by 102 mm) lumber spaced 16 in. (406 mm) OC. Steel studs to be min 2-1/2 in. (64 mm) wide and spaced max 24 in. (610 mm) OC.

B. **Gypsum Board\*** — 5/8 in. (16 mm) thick, 4 ft (122 cm) wide with square or tapered edges. The gypsum board type, thickness, number of layers, fastener type and sheet orientation shall be as specified in the individual Wall and Partition Design in the UL Fire Resistance Directory. Max diam of opening is 5 -1/2 in. (140 mm).

**The hourly F, FH rating of the firestop system is equal to the hourly fire rating of the wall assembly in which it is installed.**

2. **Cables** — Aggregate cross-sectional area of cables in steel sleeve to be 36 percent of the aggregate cross-sectional area of the sleeve. Cables to be rigidly supported on both sides of wall assembly. Any combination of the following types and sizes of copper conductor cable may be used:

A. Max 300 kcmil single conductor Type MTW, THHN, THWN or AWM power cables; cross-linked polyethylene (XLPE) insulation.

B. Max 4 pair No. 24 AWG telephone cable intended for plenum applications.

C. Max 3/C No. 12 AWG with polyvinyl chloride (PVC) insulation and jacket.

3. **Firestop System** — The firestop system shall consist of the following:

A. **Fill, Void or Cavity Material\* — Sealant or Putty** — Min 5/8 in. (16 mm) thickness of fill material applied within the annulus, flush with both sides of wall. At point contact, a min 1/2 in. (13 mm) bead of fill material shall be applied at sleeve/wall interface when sleeve extends beyond surface of wall.

**HILTI CONSTRUCTION CHEMICALS, DIV OF HILTI INC** — FS-ONE Sealant, FS-ONE MAX Intumescent Sealant or CP618 Firestop Putty Stick

B. **Steel Sleeve** — Nom 4 in. (102 mm) diam (or smaller) steel electrical metallic tubing (EMT) or Schedule 5 steel pipe. The annular space between steel sleeve and periphery of opening shall be min 0 in. (point contact) to max 1 in. (25 mm). Sleeve may extend up to 18 in. (457 mm) beyond the wall surfaces. When sleeve extends more than 4 in (102 mm) beyond surface of wall, sleeve to be rigidly supported.

C. **Packing Material** — Min 1 in. (25 mm) thickness of min 4.0 pcf (64 kg/m<sup>3</sup>) mineral wool batt insulation firmly packed into each end of sleeve as a permanent form. Packing material to be recessed from each end of sleeve as required to accommodate the required thickness of fill material.

D. **Fill, Void or Cavity Material\* — Putty** — Min 1 in. (25 mm) thickness of fill material applied within the sleeve, flush with both ends.

**HILTI CONSTRUCTION CHEMICALS, DIV OF HILTI INC** — CP618 Firestop Putty Stick

**\* Indicates such products shall bear the UL or cUL Certification Mark for jurisdictions employing the UL or cUL Certification (such as Canada), respectively.**

Last Updated on 2015-01-26

[Questions?](#)

[Print this page](#)

[Terms of Use](#)

[Page Top](#)

© 2015 UL LLC

When the UL Leaf Mark is on the product, or when the word "Environment" is included in the UL Mark, please search the [UL Environment database](#) for additional information regarding this product's certification.

The appearance of a company's name or product in this database does not in itself assure that products so identified have been manufactured under UL's Follow-Up Service. Only those products bearing the UL Mark should be considered to be Certified and covered under UL's Follow-Up Service. Always look for the Mark on the product.

UL permits the reproduction of the material contained in the Online Certification Directory subject to the following conditions: 1. The Guide Information, Assemblies, Constructions, Designs, Systems, and/or Certifications (files) must be presented in their entirety and in a non-misleading manner, without any manipulation of the data (or drawings). 2. The statement "Reprinted from the Online Certifications Directory with permission from UL" must appear adjacent to the extracted material. In addition, the reprinted material must include a copyright notice in the following format: "© 2015 UL LLC".



## System No. W-L-4011 XHEZ.W-L-4011 Through-penetration Firestop Systems

[Page Bottom](#)

### Design/System/Construction/Assembly Usage Disclaimer

- Authorities Having Jurisdiction should be consulted in all cases as to the particular requirements covering the installation and use of UL Certified products, equipment, system, devices, and materials.
- Authorities Having Jurisdiction should be consulted before construction.
- Fire resistance assemblies and products are developed by the design submitter and have been investigated by UL for compliance with applicable requirements. The published information cannot always address every construction nuance encountered in the field.
- When field issues arise, it is recommended the first contact for assistance be the technical service staff provided by the product manufacturer noted for the design. Users of fire resistance assemblies are advised to consult the general Guide Information for each product category and each group of assemblies. The Guide Information includes specifics concerning alternate materials and alternate methods of construction.
- Only products which bear UL's Mark are considered Certified.

### XHEZ - Through-penetration Firestop Systems

### XHEZ7 - Through-penetration Firestop Systems Certified for Canada

[See General Information for Through-penetration Firestop Systems](#)

[See General Information for Through-penetration Firestop Systems Certified for Canada](#)

### System No. W-L-4011

January 23, 2015

ANSI/UL1479 (ASTM E814)	CAN/ULC S115
F Ratings — 1 and 2 Hr (See Item 1)	F Ratings — 1 and 2 Hr (See Item 1)
T Rating — 0 Hr	FT Rating — 0 Hr
L Rating At Ambient — 5 CFM/sq ft	FH Ratings — 1 and 2 Hr (See Item 1)
L Rating At 400 F — 2 CFM/sq ft	FTH Rating — 0 Hr
	L Rating At Ambient — 5 CFM/sq ft
	L Rating At 400 F — 2 CFM/sq ft

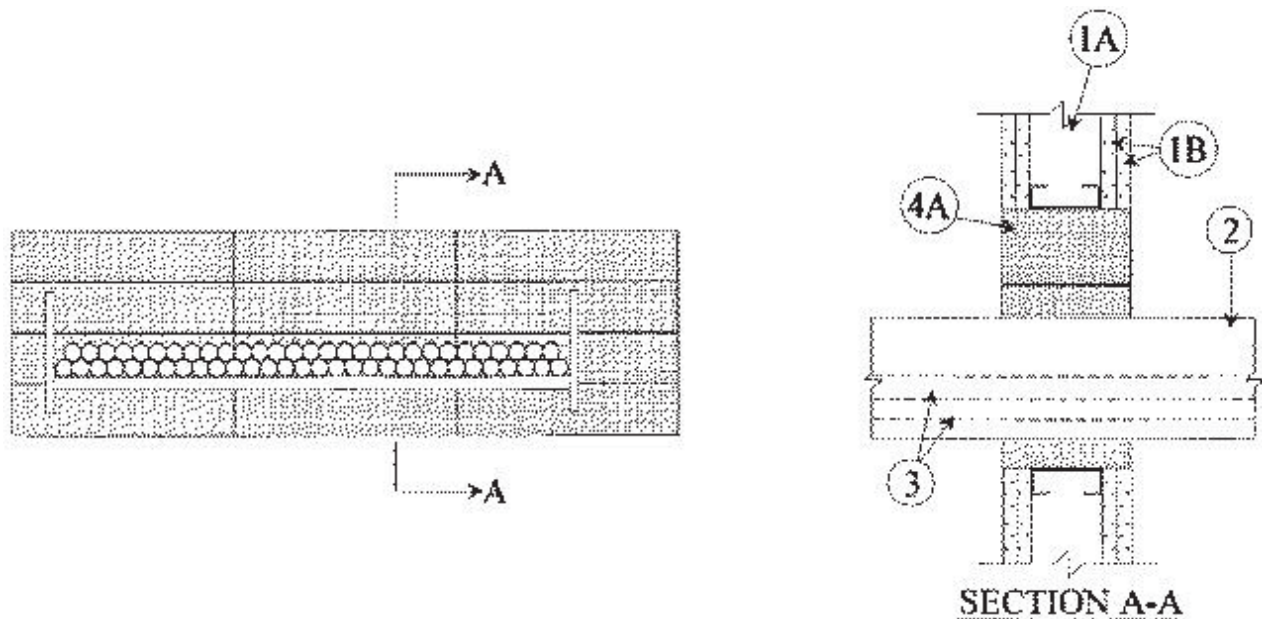

1. **Wall Assembly** — The 1 or 2 hr fire rated gypsum board/stud wall assembly shall be constructed of the materials and in the manner described in the individual U300, U400, V400 or W400 Series Wall and Partition Designs in the UL Fire Resistance Directory and shall include the following construction features:

A. **Studs** — Wall framing may consist of either wood studs or steel channel studs. Wood studs to consist of nom 2 in. (51 mm) by 4 in. (102 mm) lumber spaced 16 in. (406 mm) OC. Steel studs to be min 2-1/2 in. (64 mm) wide and spaced max 24 in. (610 mm) OC. Additional framing member shall be installed in stud cavity containing through-penetrating item to form a rectangular box around penetrant.

B. **Gypsum Board\*** — 5/8 in. (16 mm) thick, 4 ft (1219 mm) wide with square or tapered edges. The gypsum board type, thickness, number of layers, fastener type and sheet orientation shall be as specified in the individual Wall and Partition Design in the UL Fire Resistance Directory. Max size of opening 9 in. (229 mm) by 30 in. (762 mm).

**The hourly F and FH Ratings of the firestop system are equal to the hourly fire rating of the wall assembly in which it is installed.**

Min finished wall thickness is 5 in. (127 mm).

2. **Cable Tray\*** — Max 24 in. (610 mm) wide by max 6 in. (152 mm) deep open-ladder or solid-back cable tray with channel-shaped side rails formed of 0.10 in. (2.54 mm) thick aluminum or 0.060 in. (1.54 mm) thick steel and with 1-1/2 in. (38 mm) wide by 1 in. (25 mm) channel shape rungs spaced 9 in. (229 mm) OC or a 0.029 in. (0.74 mm) thick steel solid back, respectively. The annular space between the cable tray and the periphery of the opening shall be min 0 in. (point contact) to max 4 in. (102 mm). Cable tray to be rigidly supported on both sides of floor or wall assembly.

3. **Cables** — Aggregate cross-sectional area of cables in cable tray to be max 45 percent of the cross-sectional area of the cable tray based on a max 5 in. (127 mm) cable loading depth. Any combination of the following types and sizes of copper conductor cables may be used:

- A. 1/C, 750 kcmil (or smaller) power cable with EPR insulation and PVC jacket.
- B. 300 pair — No. 24 AWG cable with PVC insulation and jacket
- C. Twenty-four fiberoptic cable with PVC subunit and jacket.
- D. Max three 1/C, No. 12 AWG wire, insulated with polyvinyl chloride, in a nom 3/4 in. (19 mm) **Flexible Metal Conduit+**.

4. **Firestop System** — The firestop system shall consist of the following:

A. **Fill, Void or Cavity Material\* - Fire Blocks** — For walls incorporating max 3-5/8 in. (92 mm) steel studs or max 2 in. (51 mm) by 4 in. (102 mm) wood studs, fire block installed with 5 in. (127 mm) dimension projecting through and centered in opening. For walls constructed of larger steel or wood studs, fire block installed with long dimension passing through and centered in opening. Blocks may or may not be cut flush with both surfaces of wall. When multiple layers of gypsum board are used, blocks may be recessed 1/2 in. (13 mm) from surface of wall. Blocks firmly packed within opening. Either one or a combination of the block types specified below may be used.

**HILTI CONSTRUCTION CHEMICALS, DIV OF HILTI INC** — FS-657 Fire Block or CFS-BL Firestop Block

B. **Fill, Void or Cavity Material\* - Sealant or Putty (Not shown)** — Fill material to be forced into interstices of cables and between cables and cable trays to max extent possible on both surfaces of the penetration.

**HILTI CONSTRUCTION CHEMICALS, DIV OF HILTI INC** — FS-ONE Sealant, FS-ONE MAX Intumescent Sealant or CP618 Firestop Putty Stick (Note: L Ratings apply only when FS-One Sealant is used)

+Bearing the UL Listing Mark

**\* Indicates such products shall bear the UL or cUL Certification Mark for jurisdictions employing the UL or cUL Certification (such as Canada), respectively.**

Last Updated on 2015-01-23

---

[Questions?](#)

[Print this page](#)

[Terms of Use](#)

[Page Top](#)

© 2015 UL LLC

When the UL Leaf Mark is on the product, or when the word "Environment" is included in the UL Mark, please search the [UL Environment database](#) for additional information regarding this product's certification.

The appearance of a company's name or product in this database does not in itself assure that products so identified have been manufactured under UL's Follow-Up Service. Only those products bearing the UL Mark should be considered to be Certified and covered under UL's Follow-Up Service. Always look for the Mark on the product.

UL permits the reproduction of the material contained in the Online Certification Directory subject to the following conditions: 1. The Guide Information, Assemblies, Constructions, Designs, Systems, and/or Certifications (files) must be presented in their entirety and in a non-misleading manner, without any manipulation of the data (or drawings). 2. The statement "Reprinted from the Online Certifications Directory with permission from UL" must appear adjacent to the extracted material. In addition, the reprinted material must include a copyright notice in the following format: "© 2015 UL LLC".



## System No. W-L-5025 XHEZ.W-L-5025 Through-penetration Firestop Systems

[Page Bottom](#)

### Design/System/Construction/Assembly Usage Disclaimer

- Authorities Having Jurisdiction should be consulted in all cases as to the particular requirements covering the installation and use of UL Certified products, equipment, system, devices, and materials.
- Authorities Having Jurisdiction should be consulted before construction.
- Fire resistance assemblies and products are developed by the design submitter and have been investigated by UL for compliance with applicable requirements. The published information cannot always address every construction nuance encountered in the field.
- When field issues arise, it is recommended the first contact for assistance be the technical service staff provided by the product manufacturer noted for the design. Users of fire resistance assemblies are advised to consult the general Guide Information for each product category and each group of assemblies. The Guide Information includes specifics concerning alternate materials and alternate methods of construction.
- Only products which bear UL's Mark are considered Certified.

### XHEZ - Through-penetration Firestop Systems

### XHEZ7 - Through-penetration Firestop Systems Certified for Canada

[See General Information for Through-penetration Firestop Systems](#)

[See General Information for Through-penetration Firestop Systems Certified for Canada](#)

### System No. W-L-5025

January 27, 2015

ANSI/UL1479 (ASTM E814)	CAN/ULC S115
F Rating — 1 and 2 Hr (See Items 1 and 6)	F Rating — 1 and 2 Hr (See Items 1 and 6)
T Rating — 0 and 3/4 Hr (See Item 1)	FT Rating — 0 and 3/4 Hr (See Item 1)
L Rating At Ambient — 4 CFM/sq ft	FH Rating — 1 and 2 Hr (See Items 1 and 6)
L Rating At 400 F — Less Than 1 CFM/sq ft	FTH Rating — 0 and 3/4 Hr (See Item 1)
W Rating — Class 1 (See Item 2B)	L Rating At Ambient — 4 CFM/sq ft
	L Rating At 400 F — Less Than 1 CFM/sq ft

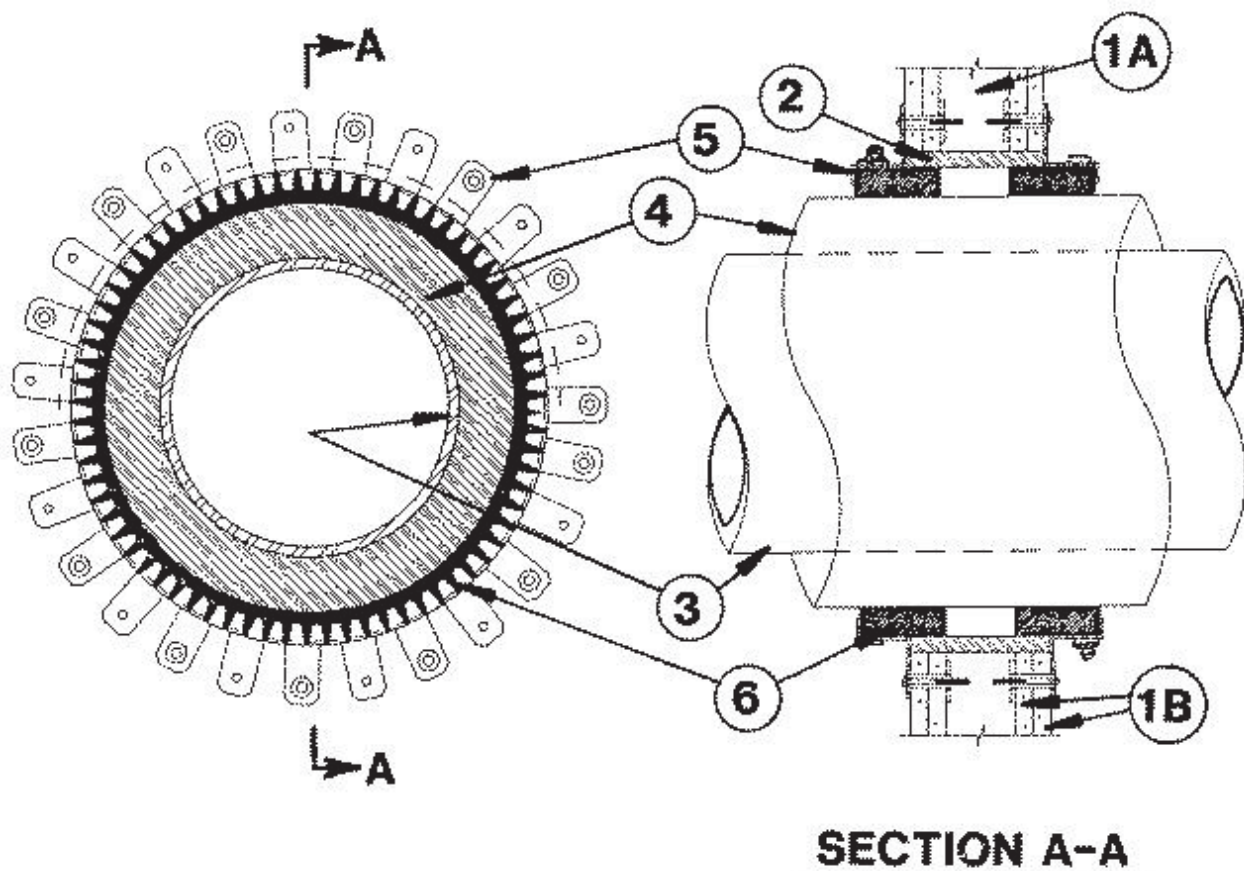

## SECTION A-A

**1. Wall Assembly** — The 1 or 2 hr fire-rated gypsum wallboard/stud wall assembly shall be constructed of the materials and in the manner specified in the individual U300, U400, V400 or W400 Series Wall and Partition Designs in the UL Fire Resistance Directory and shall include the following construction features:

**A. Studs** — Wall framing may consist of either wood studs or steel channel studs. Wood studs to consist of nom 2 by 4 in. (51 by 102 mm) lumber spaced 16 in. (406 mm) OC. Steel studs to be min 2-1/2 in. (64 mm) wide and spaced max 24 in. (610 mm) OC.

**B. Gypsum Board\*** — 5/8 in. (16 mm) thick, 4 ft (122 cm) wide with square or tapered edges. The gypsum wallboard type, number of layers, fastener type and sheet orientation shall be as specified in the individual Wall and Partition Design. Max diam of opening is 14-1/2 in. (368 mm) for wood stud walls and 18 in. (457 mm) for steel stud walls.

**The hourly F, FH Ratings of the firestop system are equal to the hourly fire rating of the wall assembly in which it is installed. The T, FT, FTH Ratings are 0 and 3/4 hr when installed in 1 and 2 hr rated walls, respectively.**

**2. Metallic Sleeve** — (Optional) — Nom 18 in. (457 mm) diam (or smaller) Schedule 40 (or thinner) steel pipe cast into wall assembly with joint compound and installed flush with wall surfaces.

**3. Through-Penetrants** — One metallic pipe or tubing to be centered within the firestop system. Pipe or tubing to be rigidly supported on both sides of wall assembly. The following types and sizes of metallic pipes or tubing may be used:

**A. Steel Pipe** — Nom 10 in. (254 mm) diam (or smaller) Schedule 10 (or heavier) steel pipe.

**B. Copper Tubing** — Nom 4 in. (102 mm) diam (or smaller) Type L (or heavier) copper tubing.

**C. Copper Pipe** — Nom 4 in. (102 mm) diam (or smaller) Regular (or heavier) copper pipe.

**4. Pipe Covering\*** — Nom 2 in. (51 mm) thick hollow cylindrical heavy density (min 3.5 pcf or 56 kg/m<sup>3</sup>) glass fiber units jacketed on the outside with an all service jacket. Longitudinal joints sealed with metal fasteners or factory-applied self-sealing lap tape. Transverse joints secured with metal fasteners or with butt tape supplied with the product. A nom annular space of 1-1/8 in. (29 mm) is required within the firestop system.

See **Pipe and Equipment Covering — Materials (BRGU)** category in the Building Material Directory for the names of manufacturers. Any pipe covering material meeting the above specifications and bearing the UL Classification Marking with a Flame Spread Index of 25 or less and a Smoke Developed Index of 50 or less may be used.

**5. Steel Collar** — Collar fabricated from precut 0.017 in. (0.43 mm) thick (28 MSG) galv sheet steel available from the sealant manufacturer. Collar shall be nom 2 in. (51 mm) deep with min 1-1/4 in. (32 mm) wide by 2 in. (51 mm) long anchor tabs for securement to wall surface. Retainer tabs, 1/4 in. (6 mm) wide by 3/4 in. (19 mm) long and located opposite the anchor tabs are folded 90 degrees toward pipe surface to maintain the annular space around the pipe and to retain the fill material. Collar secured to surface of wall with 1/4 in. (6 mm) toggle bolts. A nom 1/2 in. (13 mm) wide stainless steel hose clamp was secured to each of the collars at mid-depth.



**6. Fill, Void or Cavity Material\* – Sealant** — In 1 hr fire rated assemblies, min 5/8 in. (16 mm) thickness of fill material applied within the annulus. In 2 hr fire rated assemblies, min 1-1/4 in. (32 mm) thickness of fill material applied within the annulus. Additional fill material applied to completely fill the collars.

**HILTI CONSTRUCTION CHEMICALS, DIV OF HILTI INC** — FS-One Sealant or FS-ONE MAX Intumescent Sealant

**\* Indicates such products shall bear the UL or cUL Certification Mark for jurisdictions employing the UL or cUL Certification (such as Canada), respectively.**

Last Updated on 2015-01-27

---

[Questions?](#)

[Print this page](#)

[Terms of Use](#)

[Page Top](#)

© 2015 UL LLC

When the UL Leaf Mark is on the product, or when the word "Environment" is included in the UL Mark, please search the [UL Environment database](#) for additional information regarding this product's certification.

The appearance of a company's name or product in this database does not in itself assure that products so identified have been manufactured under UL's Follow-Up Service. Only those products bearing the UL Mark should be considered to be Certified and covered under UL's Follow-Up Service. Always look for the Mark on the product.

UL permits the reproduction of the material contained in the Online Certification Directory subject to the following conditions: 1. The Guide Information, Assemblies, Constructions, Designs, Systems, and/or Certifications (files) must be presented in their entirety and in a non-misleading manner, without any manipulation of the data (or drawings). 2. The statement "Reprinted from the Online Certifications Directory with permission from UL" must appear adjacent to the extracted material. In addition, the reprinted material must include a copyright notice in the following format: "© 2015 UL LLC".

**SECTION 079200 - JOINT SEALANTS**

## PART 1 - GENERAL

## 1.1 RELATED DOCUMENTS

- A. Drawings and general provisions of the Contract, including General and Supplementary Conditions and Division 1 Specification Sections, apply to this Section.

## 1.2 SUMMARY

- A. This Section includes sealants for the following applications, including those specified by reference to this Section:

1. Exterior joints in the following vertical surfaces and nontraffic horizontal surfaces:
  - a. Perimeter joints between materials listed above and frames of doors and windows.
2. Exterior joints in the following horizontal traffic surfaces:
  - a. Control, expansion, and isolation joints in cast-in-place concrete slabs.
3. Interior joints in the following vertical surfaces and horizontal nontraffic surfaces:
  - a. Vertical control joints on exposed surfaces of interior unit masonry and concrete walls and partitions.
  - b. Perimeter joints between interior wall surfaces and frames of interior doors, windows, and elevator entrances.
  - c. Joints between plumbing fixtures and adjoining walls, floors, and counters.
  - d. Other joints as indicated.

## 1.3 PERFORMANCE REQUIREMENTS

- A. Provide elastomeric joint sealants that establish and maintain watertight and airtight continuous joint seals without staining or deteriorating joint substrates.

## 1.4 SUBMITTALS

- A. Product Data: For each joint-sealant product indicated.

## 1.5 DELIVERY, STORAGE, AND HANDLING

- A. Deliver materials to Project site in original unopened containers or bundles with labels indicating manufacturer, product name and designation, color, expiration date, pot life, curing time, and mixing instructions for multicomponent materials.

- B. Store and handle materials in compliance with manufacturer's written instructions to prevent their deterioration or damage due to moisture, high or low temperatures, contaminants, or other causes.

#### 1.6 PROJECT CONDITIONS

- A. Environmental Limitations: Do not proceed with installation of joint sealants under the following conditions:
  - 1. When ambient and substrate temperature conditions are outside limits permitted by joint sealant manufacturer.
- B. Joint-Width Conditions: Do not proceed with installation of joint sealants where joint widths are less than those allowed by joint sealant manufacturer for applications indicated.
- C. Joint-Substrate Conditions: Do not proceed with installation of joint sealants until contaminants capable of interfering with adhesion are removed from joint substrates.

### PART 2 - PRODUCTS

#### 2.1 PRODUCTS AND MANUFACTURERS

- A. Products: Subject to compliance with requirements, provide one of the products indicated for each type in the sealant schedules at the end of Part 3.

#### 2.2 MATERIALS, GENERAL

- A. Compatibility: Provide joint sealants, backings, and other related materials that are compatible with one another and with joint substrates under conditions of service and application, as demonstrated by sealant manufacturer based on testing and field experience.
- B. Colors of Exposed Joint Sealants: As selected by Architect from manufacturer's full range for this characteristic.

#### 2.3 ELASTOMERIC JOINT SEALANTS

- A. Elastomeric Sealant Standard: Comply with ASTM C 920 and other requirements indicated for each liquid-applied chemically curing sealant in the Elastomeric Joint-Sealant Schedule at the end of Part 3, including those referencing ASTM C 920 classifications for type, grade, class, and uses.

#### 2.4 ACOUSTICAL JOINT SEALANTS

- A. Acoustical Sealant for Exposed and Concealed Joints: For each product of this description indicated in the Acoustical Joint-Sealant Schedule at the end of Part 3, provide manufacturer's standard nonsag, paintable, nonstaining latex sealant complying with ASTM C 834 and the following:

1. Product effectively reduces airborne sound transmission through perimeter joints and openings in building construction as demonstrated by testing representative assemblies according to ASTM E 90.

## 2.5 JOINT-SEALANT BACKING

- A. General: Provide sealant backings of material and type that are nonstaining; are compatible with joint substrates, sealants, primers, and other joint fillers; and are approved for applications indicated by sealant manufacturer based on field experience and laboratory testing.

## 2.6 MISCELLANEOUS MATERIALS

- A. Primer: Material recommended by joint sealant manufacturer where required for adhesion of sealant to joint substrates indicated, as determined from preconstruction joint-sealant-substrate tests and field tests.
- B. Cleaners for Nonporous Surfaces: Chemical cleaners acceptable to manufacturers of sealants and sealant backing materials, free of oily residues or other substances capable of staining or harming joint substrates and adjacent nonporous surfaces in any way, and formulated to promote optimum adhesion of sealants with joint substrates.
- C. Masking Tape: Nonstaining, nonabsorbent material compatible with joint sealants and surfaces adjacent to joints.

## PART 3 - EXECUTION

### 3.1 EXAMINATION

- A. Examine joints indicated to receive joint sealants, with Installer present, for compliance with requirements for joint configuration, installation tolerances, and other conditions affecting joint-sealant performance.
- B. Proceed with installation only after unsatisfactory conditions have been corrected.

### 3.2 PREPARATION

- A. Surface Cleaning of Joints: Clean out joints immediately before installing joint sealants to comply with joint sealant manufacturer's written instructions and the following requirements:
  1. Remove all foreign material from joint substrates that could interfere with adhesion of joint sealant, including dust, paints (except for permanent, protective coatings tested and approved for sealant adhesion and compatibility by sealant manufacturer), old joint sealants, oil, grease, waterproofing, water repellents, water, surface dirt, and frost.
  2. Clean porous joint substrate surfaces by brushing, grinding, blast cleaning, mechanical abrading, or a combination of these methods to produce a clean, sound substrate capable of developing optimum bond with joint sealants. Remove loose particles remaining from above cleaning operations by vacuuming

or blowing out joints with oil-free compressed air. Porous joint surfaces include the following:

- a. Concrete.
- b. Masonry.
- c. Unglazed surfaces of ceramic tile.

3. Remove laitance and form-release agents from concrete.

- B. Joint Priming: Prime joint substrates where recommended in writing by joint sealant manufacturer, based on preconstruction joint-sealant-substrate tests or prior experience. Apply primer to comply with joint sealant manufacturer's written instructions. Confine primers to areas of joint-sealant bond; do not allow spillage or migration onto adjoining surfaces.
- C. Masking Tape: Use masking tape where required to prevent contact of sealant with adjoining surfaces that otherwise would be permanently stained or damaged by such contact or by cleaning methods required to remove sealant smears. Remove tape immediately after tooling without disturbing joint seal.

### 3.3 INSTALLATION OF JOINT SEALANTS

- A. General: Comply with joint sealant manufacturer's written installation instructions for products and applications indicated, unless more stringent requirements apply.
- B. Sealant Installation Standard: Comply with recommendations of ASTM C 1193 for use of joint sealants as applicable to materials, applications, and conditions indicated.
- C. Acoustical Sealant Application Standard: Comply with recommendations of ASTM C 919 for use of joint sealants in acoustical applications as applicable to materials, applications, and conditions indicated.
- D. Install sealant backings of type indicated to support sealants during application and at position required to produce cross-sectional shapes and depths of installed sealants relative to joint widths that allow optimum sealant movement capability.
- E. Install bond-breaker tape behind sealants where sealant backings are not used between sealants and back of joints.
- F. Install sealants by proven techniques to comply with the following and at the same time backings are installed:
  1. Place sealants so they directly contact and fully wet joint substrates.
  2. Completely fill recesses provided for each joint configuration.
  3. Produce uniform, cross-sectional shapes and depths relative to joint widths that allow optimum sealant movement capability.
- G. Tooling of Nonsag Sealants: Immediately after sealant application and before skinning or curing begins, tool sealants according to requirements specified below to form smooth, uniform beads of configuration indicated; to eliminate air pockets; and to ensure contact and adhesion of sealant with sides of joint.

1. Remove excess sealants from surfaces adjacent to joint.
2. Use tooling agents that are approved in writing by sealant manufacturer and that do not discolor sealants or adjacent surfaces.

### 3.4 CLEANING

- A. Clean off excess sealants or sealant smears adjacent to joints as the Work progresses by methods and with cleaning materials approved in writing by manufacturers of joint sealants and of products in which joints occur.

### 3.5 PROTECTION

- A. Protect joint sealants during and after curing period from contact with contaminating substances and from damage resulting from construction operations or other causes so sealants are without deterioration or damage at time of Substantial Completion. If, despite such protection, damage or deterioration occurs, cut out and remove damaged or deteriorated joint sealants immediately so installations with repaired areas are indistinguishable from the original work.

### 3.6 ELASTOMERIC JOINT-SEALANT SCHEDULE

- A. Multicomponent Nonsag Polysulfide Sealant: Where joint sealants of this type are indicated, provide products complying with the following:
  1. Products: Provide one of the following:
    - a. cm-60; W.R Meadows, Inc.
    - b. T-2235-M; Morton International, Inc.
    - c. T-2282; Morton International, Inc.
    - d. Thiokol 2P; Morton International, Inc.
    - e. GC-5 Synthacalk; Pecora Corporation.
    - f. Two-Part Sealant; Sonneborn Building Products Div., ChemRex Inc.
  2. Type and Grade: M (multicomponent) and NS (nonsag).
  3. Class: 25.
  4. Uses Related to Exposure: T (traffic)

### 3.7 LATEX JOINT-SEALANT SCHEDULE

- A. Latex Sealant: Where joint sealants of this type are indicated, provide products complying with the following:
  1. Products: Provide one of the following:
    - a. Chem-Calk 600; Bostik Inc.
    - b. NuFlex 330; NUCO Industries, Inc.
    - c. LC 160 All Purpose Acrylic Caulk; Ohio Sealants, Inc.
    - d. AC-20; Pecora Corporation.
    - e. PSI-701; Polymeric Systems, Inc.
    - f. Sonolac; Sonneborn Building Products Div., ChemRex, Inc.
    - g. Tremflex 834; Tremco.

## 3.8 ACOUSTICAL JOINT-SEALANT SCHEDULE

- A. Acoustical Sealant for Exposed and Concealed Joints: At all sound partitions and where joint sealants of this type are indicated, provide products complying with the following:
1. Products: Provide one of the following:
    - a. AC-20 FTR Acoustical and Insulation Sealant; Pecora Corporation.
    - b. SHEETROCK Acoustical Sealant; USG Corp., United States Gypsum Co.
- B. Acoustical Sealant for Concealed Joints: At all sound partitions and where joint sealants of this type are indicated, provide products complying with the following:
1. Products: Provide one of the following:
    - a. Pro-Series SC-170 Rubber Base Sound Sealant; Ohio Sealants, Inc.
    - b. BA-98; Pecora Corporation.
    - c. Tremco Acoustical Sealant; Tremco.

END OF SECTION

**SECTION 081113 – HOLLOW METAL DOORS AND FRAMES**

## PART 1 - GENERAL

## 1.1 SUMMARY

- A. Work Included: Provide and install hollow metal doors and frames, complete, as shown on Drawings and as specified.
  - 1. Hollow Metal Door and Frame Sets.
  - 2. Hollow Metal Interior Window Frames.
  - 3. Hollow Metal Frames for Wood Doors specified in Section 081416 – Flush Wood Doors.
  - 4. Coordinate Door and Frame fabrication with door hardware specified in Section 087100 – Door Hardware as required for the hardware types scheduled on Drawings.
  - 5. Coordinate Door and Frame fabrication with Security and Access Control products specified in DIVISION 26 – Electrical as required for Security and Fire Alarm wiring and interface.
- B. Work Specified Elsewhere:
  - 1. Section 050500 – Metal Fasteners.
  - 2. Section 081416– Flush Wood Doors.
  - 3. Section 084113– Aluminum Entrances and Storefronts.
  - 4. Section 084213– Aluminum Framed Entrance
  - 5. Section 087100 – Door Hardware.
  - 7. Section 088000 –Glazing.
  - 8. Section 085113 – Aluminum Windows.

## 1.2 REFERENCE STANDARDS

- A. Hollow Metal Manufacturers Association (HMMA) Division of National Association of Architectural Metal Manufacturers (NAAMM):
  - 1. Hollow Metal Manual; including HMMA 800, 801, 802, 810, 820, 830, 840, 841, 850, 860, 861, 862, 863, 880, 881, and 882.

## 1.3 QUALITY ASSURANCE

- A. Comply with the latest edition of the following Standards:
  - 1. National Fire Protection Association (NFPA):



- a. NFPA No. 80: "Fire Doors and Windows".
  - b. NFPA No. 251: "Fire Tests of Building Construction and Materials".
  - c. NFPA No. 252: "Fire Tests of Door Assemblies".
  - d. NFPA No. 257: "Fire Tests of Window Assemblies".
2. American Society for Testing and Materials (ASTM):
    - a. ASTM E-119: "Methods for Fire Tests of Building Construction and Materials".
    - b. ASTM E-152: "Standard Methods of Fire Tests of Door Assemblies."
    - c. ASTM E-163: "Methods for Fire Tests of Window Assemblies".
  3. American National Standards Institute (ANSI):
    - a. A250.8: "Recommended Specifications for Standard Steel Doors and Frames".
  4. Underwriters' Laboratories' (UL):
    - a. UL-9: "Fire Tests of Door Assemblies".
    - b. UL-10C: "Fire Tests of Window Assemblies".
- B. Testing Agency Qualifications: Testing agency testing all fire rated doors and frames, shall have approval of enforcing authority for this project and provide inspection of materials and workmanship at factory during fabrication and assembly.
- C. Requirements of Regulatory Agencies: Where opening has fire resistive rating of 20 minutes or longer, door shall bear testing agency-issued label.
- a. Provide "T" temperature rating labels.

#### 1.4 SUBMITTALS

- A. Comply with provisions of Section 013300 – Submittal Procedures.
- B. Product Data: Manufacturer's specifications, catalog cuts, data, and installation instructions.
- C. Shop Drawings:
  1. General: Show frame type, material descriptions and gauges, exact profiles, elevations, fire-resistive rating and complete details, including reinforcing, anchors, and connections.
    - a. Identify non-conforming frames and assemblies that cannot be fire rated or labeled for Architect's review and direction.

2. Provide Elevation Drawings for each frame assembly, fully dimensioned and identified by numbering nomenclature used on Drawings, including:
    - a. Locations of rough-in and reinforcing preparation for hardware provided in other Sections.
    - b. Routing of electrical conduit or cable within frame members.
    - c. Glass Type for each Lite, incorporating nomenclature used on Drawings.
    - d. Locations of Doors, including swing and Door numbering nomenclature used on Drawings.
    - e. Frame Finish.
  3. Provide full-size special details showing thickness, profiles, jointing, connections, and assembly of various members, reinforcement, anchorage, and supports.
- D. Samples: Submit 12-inch by 12-inch "L" section of metal door frame showing corner detail, anchor, weld, and finish.
- E. Certificates: Submit certificates for specified doors and frames indicating compliance with fabrication and minimum labeling requirements. Certificates signed by Contractor and authorized representative of hollow metal manufacturing company.

#### 1.6 PRODUCT HANDLING

- A. General: Deliver, store, and handle hollow metal work in manner to prevent damage, distortion, and deterioration.
- B. Packaging: Package hollow metal work in cardboard or other containers with separators, banding, spreaders, and paper wrappings to protect items during transit and Project site storage.
- C. Manufacturer's Recommendations: Follow special storage and handling requirements of manufacturer.
- D. Identification: Mark each door and door frame, on a surface which will be hidden after installation, with designation of opening for which it is furnished. Mark opening designation also on exterior packaging for each door and door frame.

#### 1.7 COORDINATION

- A. Hardware Suppliers: Furnish hollow metal frame manufacturer with accepted hardware schedule, hardware templates, and samples of physical hardware where necessary to ensure correct fitting and installation.

### PART 2 - PRODUCTS

## 2.1 MANUFACTURERS

- A. General: Provide products manufactured by Stiles Custom Metal, Inc; Curries Company, an ASSA ABLOY Group Company; Steelcraft, an Ingersoll Rand Company OR Ceco, an ASSA ABLOY Group Company

## 2.2 MATERIALS – GENERAL

## A. Steel Sheet:

1. General: Free of scale, pitting, and surface defects.
2. Cold-Rolled: ASTM A366, commercial grade.
3. Hot-Rolled: ASTM A569, commercial grade, pickled.
4. Galvanized: Cold-rolled or hot-rolled sheet with zinc coating applied by hot-dip process per ASTM A526 (A60 or G60) with coating weight of not less than 0.30 ounces per square foot per side.

## 2.3 HOLLOW METAL DOORS

## A. Faces:

1. Interior Doors: Cold-rolled or hot-rolled steel sheet; not less than 18 gauge.
2. Exterior Doors: Galvanized steel sheet, not less than 16 gauge.

## B. Door Thickness: 1-3/4-inches, unless otherwise shown.

## C. Door Types: Flush. Fully-welded seamless construction with no visible seams or joints on faces or vertical edges.

## D. Door Construction:

1. General: Fabricate doors in conformance with ANSI A250.8, including:
  - a. Level and Physical Performance Level: Level 3 and Extra heavy Duty per ANSI A250.8.
  - b. Model: 2 (Seamless per ANSI A250.8).
2. Reinforcement: Stiffen face sheets by continuous vertical formed steel stiffener sections spanning full thickness of interior space between door faces.
3. Stiffeners: Not less than 22 gauge space not more than 6-inches apart and securely attach to face sheets by spot welds not more than 5-inches on center. Fill spaces between stiffeners to sound-deaden and insulate full height of door with an inorganic non-combustible batt-type material.

4. Door Faces: Join at vertical edges by continuous weld extending full height of door. Grind, fill, and dress welds smooth to make invisible and provide smooth flush surface.
5. Top and Bottom Edges: Close with continuous recessed steel channel not less than 16 gauge, extending full width of door and spot welded to both faces. At exterior doors provide an additional flush closing channel at top edges and, where required for attachment of weather-stripping, a flush closure also at bottom edges. Provide openings in bottom closure of exterior doors to permit escape of entrapped moisture.
6. Edge Profiles: Provide for both vertical edges of doors as follows:
  - a. Single-Acting Swing Doors: Bevel 1/8-inch in 2 inches.
  - b. Double-Acting Swing Doors: Round on 2-1/8-inch radius.
7. Hardware Reinforcements:
  - a. General: Mortise, reinforce, drill and tap doors at factory for fully-templated hardware only, per hardware schedule and templates provided by hardware suppliers specified in Section 08710 – Door Hardware, and DIVISION 16 –Electrical (Fire Alarm and Security Requirements). Where surface-mounted hardware is scheduled, provide reinforcing plates only; drilling and tapping done by others.
  - b. Minimum Gauges For Hardware Reinforcing Plates: As follows:
    - 1) Hinge and Pivot Reinforcements: 7 gauge.
    - 2) Reinforcements for Lock Face, Flush Bolts, Concealed Holders: 12 gauge.
    - 3) Reinforcements for All Other Surface-Mounted Hardware: 16 gauge.
8. Astragals:
  - a. Dutch Bend Astragal: Provide as integral part of door unless otherwise shown or scheduled. Fabricate astragal of three thickness of metal of same gauge as face sheet. Fabricate reveal on opposite door leaf from top to bottom for dutch bend astragal to lay flush with face.
  - b. Location:
    - 1) Exterior Pairs of Doors:
      - a) Outswing: Astragal on exterior side of active door leaf.
      - b) Inswinging: Astragal on exterior side of inactive leaf.
9. Louvers: Welded blade type of construction. Louvers pierced into face sheets not permitted.

10. Exterior Doors: Provide weep-hole openings in bottom of exterior doors to permit moisture to escape. Seal joints in top edges of doors against water penetration.
- E. Electrical Requirements:
1. General: Make provisions for installation of electrical items specified under Section 087100 – Door Hardware, and DIVISION 16 –Electrical (Fire Alarm and Security Requirements) and other applicable Sections; arrange in manner so wiring can be readily removed and replaced.
  2. Doors with Electric Hardware:
    - a. General: Provide with metal raceway or conduit to permit wiring from electric hinge to other electric door hardware.
    - b. Hinges or Pivot Location: Center or intermediate as applicable; top or bottom not permitted.
    - c. Install Electro Lynx wiring and Molex type connectors. Furnished by Section 087100, Door Hardware.
- 2.4 HOLLOW METAL PANELS
- A. General: Fabricate and finish hollow metal panels as specified for hollow metal doors.
- 2.5 HOLLOW METAL FRAMES
- A. Materials:
1. Interior Frames: Cold-rolled or hot-rolled steel sheet; not less than 16 gauge for openings 48-inches and less in width, and not less than 14 gauge for openings greater than 48-inches in width.
  2. Exterior Frames: Galvanized steel sheet; not less than 14 gauge.
- B. Fabrication:
1. General: Provide welded units with integral trim, of sizes and shapes shown. Knocked-down frames acceptable at interior non-rated openings only.
  2. Finished Work: Strong and rigid, neat in appearance, square, true and free of defects, warp or buckle. Fabricate molded members clean cut, straight and of uniform profile throughout their lengths.
  3. Jamb Depths, Trim, Profile, Returns, and Backbends: As shown.
  4. Corner Joints: Close contact edges tight, miter and continuously weld trim edges, and miter (butt) stops. Use of gussets not permitted.
  5. Stops: Minimum depth 5/8-inches.

6. Large Openings: When shipping limitations so dictate, fabricate frames for large openings in sections designed for splicing in field.
7. Multiple or Special Openings: Fabricate frames for multiple or special openings with mullion and/or rail members which are closed tubular shapes having no visible seams or joints. Securely weld joints between faces of abutting members and finish smooth.
8. Hardware Reinforcements:
  - a. General: Mortise, reinforce, drill, and tap frames at factory for fully templated mortised hardware only, per hardware schedule and templates provided by hardware supplier. Where surface-mounted hardware is to be applied, provide frames with reinforcing plates only.
  - b. Hardware Reinforcing Plates: Minimum thickness as follows:
    - 1) Hinge And Pivot Reinforcements: 7 gauge, 1-1/4-foot by 10-inches, minimum size.
    - 2) Strike Reinforcements: 12 gauge.
    - 3) Flush Bolt Reinforcements: 12 gauge.
    - 4) Closer Reinforcements: 12 gauge.
    - 5) Surface-Mounted Hardware Reinforcements: 12 gauge.
    - 6) Hold-Open Arm Reinforcements: 12 gauge.
    - 7) Surface Exit Device Reinforcements: 12 gauge.
9. Jamb Anchors:
  - a. Masonry Walls: Provide frames with adjustable jamb anchors. Anchors not less than 16-gauge steel or 0.156-inch diameter steel wire. Stirrup straps shall be not less than 2 inches by 10 inches in size, corrugated and/or perforated. Provide anchors on each jamb as follows:

Frames up to 7'-6" height: 3 anchors.  
Frames 7'-6" to 8'-0" height: 4 anchors.  
Frames over 8'-0" height: 1 anchor for each 2' or fraction thereof in height.
  - b. Stud Partitions: Provide frames with steel anchors of suitable design, not less than 18-gauge thickness, securely welded inside each jamb as follows:

Frames up to 7'-6" height: 4 anchors.  
Frames 7'-6" to 8'-0" height: 5 anchors.  
Frames over 8'-0" height: 5 anchors plus one additional for each 2' or fraction thereof over 8'-0".

- c. Previously Placed Concrete or Masonry: Provide frames to be anchored to previously placed concrete, masonry or structural steel with anchors of suitable design as shown on approved shop drawings.
  - 10. Floor Anchors:
    - a. General: Securely weld inside each jamb, with two holes provided at each jamb for floor anchorage.
    - b. Adjustable Anchors: Where so scheduled or specified, provide adjustable floor anchors, not less than 2 inches in height adjustment.
    - c. Thickness: Minimum 14 gauge.
  - 11. Masonry Wall Openings More Than 48-Inches In Width: Provide with angle or channel stiffener factory welded into head; stiffeners not less than opening width and not used as lintels or load-bearing members.
  - 12. Dust Cover Boxes: Or mortar guards, provide of not thinner than 26-gauge steel at hardware mortises on frames to be set in masonry or plaster partitions.
  - 13. Steel Spreader: Provide frames with steel spreader temporarily attached to feet of both jambs to serve as brace during shipping and handling. Steel spreader not to be used for installation purposes.
- C. Electrical Requirements:
  - 1. General: Make provisions for installation of electrical items specified under Section 087100 – Door Hardware, and DIVISION 26 –Electrical (Fire Alarm and Security Requirements) and other applicable Sections; arrange in manner so wiring can be readily removed and replaced.
  - 2. Frames with Electric Hinges:
    - a. General: Dust cover boxes or mortar guard for electrical hinges furnished under Section 087100 – Door Hardware; weld into place under this Section.
    - b. Hinge or Pivot Location: Center or intermediate as applicable; top or bottom not permitted.
  - 3. Back Box for Electrical Hardware Items: Furnished under Section 087100 – Door Hardware; weld into place under this Section.

## 2.6 FIRE-RATED DOORS AND FRAMES

- A. General: Provide labeled doors and frames for those openings requiring fire protection ratings as scheduled. Construct such doors and frames as tested and approved by UL, WHI, or other nationally recognized testing agency having factory inspection service.

- B. Non-Ratable Openings: Identify on Shop Drawings any door or frame scheduled to be fire-rated cannot qualify for appropriate labeling because of its design, hardware or any other reason. Do not begin fabrication for non-ratable items until all issues have been resolved.

## 2.7 STOPS AND MOLDINGS

- A. Moldings for Glazed Lites in Doors: Minimum 0.032 inch thick, fabricated from same material as door face sheet in which they are installed.
- B. Fixed Frame Moldings: Formed integral with standard steel frames, minimum 5/8 inch high, unless otherwise indicated.
- C. Loose Stops for Glazed Lites in Frames: Minimum 0.032 inch thick, fabricated from same material as frames in which they are installed.

## 2.8 SHOP PAINTING

- A. General: Comply with NAAMM's "Metal Finishes Manual for Architectural and Metal Products" for recommendations for applying and designating finishes.
  - 1. Finish standard steel door and frames after assembly.
- B. Galvanized Steel Surface Preparation: Clean surfaces with nonpetroleum solvent so surfaces are free of oil and other contaminants. After cleaning, apply a conversion coating suited to the organic coating to be applied over it. Clean welds, mechanical connections, and abraded areas, and apply galvanizing repair paint specified below to comply with ASTM A 780.
  - 1. Galvanizing Repair Paint: High-zinc-dust-content paint for regalvanizing welds in steel, complying with SSPC-Paint 20.
- C. Steel Surface Preparation: Clean surfaces to comply with SSPC-SP 1, "Solvent Cleaning"; remove dirt, oil, grease, or other contaminants that could impair paint bond. Remove mill scale and rust, if present, from uncoated steel; comply with SSPC-SP 3, "Power Tool Cleaning," or SSPC-SP 6/NACE No. 3, "Commercial Blast Cleaning."
- D. Factory Priming for Field-Painted Finish: Apply shop primer specified below immediately after surface preparation and pretreatment. Apply a smooth coat of even consistency to provide a uniform dry film thickness of not less than 0.7-mils.
- E. Shop Primer: Manufacturer's standard, fast-curing, lead- and chromate-free primer complying with ANSI A250.10 acceptance criteria; recommended by primer manufacturer for substrate; compatible with substrate and field-applied finish paint system indicated; and providing a sound foundation for field-applied topcoats despite prolonged exposure.

## PART 3 - EXECUTION

### 3.1 EXAMINATION



- A. Verification of Conditions: Examine substrate and conditions under which hollow metal doors and frames are to be installed and give notification, in writing, of any conditions detrimental to proper and timely completion of work. Do not proceed with work until unsatisfactory conditions have been corrected.

### 3.2 INSTALLATION OF FRAMES

- A. General: Install frames per Reference Standards and as specified.
- B. Labeled Doors and Frames: Install per requirements of labeling authority.
- C. Setting: Exercise care in setting of frames to maintain scheduled dimensions, hold head level, and maintain jambs plumb and square.
- D. Anchorages and Connections: Secure to adjacent construction. Furnish anchors to suit wall conditions and floor angles or clips welded to frame for fastening to floor.
- E. Spreader Bars: Whenever possible, leave frame spreader bars intact until frames are set perfectly square and plumb and anchors are securely attached. Do not use shipping bars as spreaders.
- F. Expansion Movement: Allow for as required.
- G. Fire-Rated Frames: Install per NFPA Standard No. 80.
- H. Exterior Doors: Provide sheet metal drip at head.
- I. Frames in Metal Stud Partitions: Frames filled tight with mineral fiber safing as specified in Section 078413 – Penetration Firestopping.

### 3.3 SHOP COAT TOUCH-UP

- A. General: Immediately after installation remove rust, sand smooth, and touch-up items with prime coat which has been damaged with same primer as applied in shop.

### 3.4 ADJUSTMENT

- A. General: Replace or re-hang doors which are hinge-bound or do not swing or operate freely.

### 3.5 PROTECTION

- A. General: Protect installed work against damage from other construction work.

### 3.6 INSTALLATION OF DOORS

- A. General: Install doors per manufacturer's instructions.
- B. Hardware: Install per requirements specified in Section 087100 – Door Hardware.

- C. Adjustment: Adjust and lubricate operable parts as required for correct function.

END OF SECTION

**SECTION 081416- FLUSH WOOD DOORS**

## PART 1 - GENERAL

## 1.1 SUMMARY

- A. Work Included: Provide and install flush wood doors, complete, as shown on Drawings and as specified, including:
  - 1. Flush Wood Doors, including: Wood Veneer Flush Doors, including specified veneer and transparent finish.
  - 2. Provide rated and un-rated doors as scheduled on Drawings.
  - 3. Coordinate Door fabrication with Section 087100 – Door Hardware as required for the hardware types scheduled on Drawings.
  - 4. Coordinate Door fabrication with DIVISION 26 – Electrical as required for Security and Fire Alarm wiring and interface.
- B. Work Specified Elsewhere:
  - 1. Section 081113– Hollow Metal Doors and Frames.
  - 2. Section 084113–Aluminum Entrances and Storefronts.
  - 3. Section 087100 – Door Hardware.
  - 4. Section 088000 – Glazing.

## 1.2 REFERENCE STANDARDS

- A. National Wood Window and Door Association (NWWDA):
  - 1. IS 1.1; General Requirements for Flush Wood Doors.
  - 2. IS 1.2; Solid Core Wood Flush Doors.
  - 3. IS 1.4; Special Construction Wood Flush Doors.
  - 4. IS 1.6; Testing and Inspection Requirements for Wood Flush Doors.
- B. Standards of Woodwork Institute (WI) "Manual of Millwork."
- C. American Society for Testing Materials (ASTM):
  - 1. E-90-02: "Standard Test Method for Laboratory Measurement of Airborne Sound Transmission Loss of Building Partitions and Elements".

## 1.3 QUALITY ASSURANCE

- A. Qualifications:

1. Manufacturer: Certified and licensed per NWWDA IS 1 Series.
2. United States Product Standard (PS) "Construction and Industrial Plywood" (PS 1-74).

#### 1.4 SUBMITTALS

- A. Comply with provisions of Section 013300 – Submittal Procedures.
- B. Product Data: Manufacturer's specifications, catalog cuts, standard details, and installation details.
- C. Shop Drawings: Complete, with door schedule; show location, types, sizes, thickness, cutout details, special details and other requirements to assure proper installation.
- D. Samples:
  1. Doors: Each type showing construction, faces, edges, and specified finishes; 12-inch by 12-inch corner section.
- E. Certificates:
  1. General: Certification that doors conform to NWMA IS 1 Series.
  2. Sound Retardant Doors: Certification that doors comply with specified STC rating.

#### 1.5 EXTENDED WARRANTY

- A. Comply with requirements of Section 017600 – Guarantees and Warranties.
- B. General: Manufacturer's standard based on NWMA IS 1.1 tolerances and book sizes.
- C. Solid Core Doors:
  1. Interior: Life of original installation.

#### 1.6 PRODUCT HANDLING

- A. Delivery: Package doors per manufacturer's recommendation prior to shipment. Mark and identify doors for each opening to facilitate proper location.
- B. Storage: Store doors flat on level surfaces in clean, dry, and properly ventilated spaces.

## PART 2 - PRODUCTS

## 2.1 MANUFACTURERS

- A. Typical Flush Wood Doors: Provide wood doors manufactured by Marshfield Door Systems, VT Industries, Eggers Industries, OR Oshkosh Architectural Wood Doors

## 2.2 WOOD VENEER FACES FOR TRANSPARENT FINISH

## A. General:

1. Provide wood veneer faced flush wood doors as required to match the Architect's samples and in conformance with ANSI/HPVA HP-1; not less than 1/50-inch-thick before finish sanding.
  - a. Grade: Premium, with Grade A faces.

## B.

1. Species: **Match Existing.**
2. Cut: **Match Existing.**
3. Veneer Match: **Book Match**
4. Veneer Face Assembly: **Running Match**
3. Application:
  - a. Face Panel Grade: HPVA Grade AA.
  - b. Finish: **Species, Cut, and Finish to match adjacent doors. Please field verify before fabrication. Provide sample to architect for approval.**
4. Match between veneer leaves: **Book Match**
5. Fabrication: As specified in this Section.

## 2.3 MDO FACES FOR SHOP AND FIELD PAINTING

- A. Paint-Grade Medium Density Overlay (MDO): Conform to PS 1-74.
- B. Paint doors as specified in Section 099123 – Interior Painting.

## 2.4 FABRICATION – NON-RATED DOORS AND 20-MINUTE RATED DOORS

## A. Fabrication:

1. General: Per NWWDA IS 1 Series, Premium Grade; no finger jointing permitted.

## B. Cores:

1. Particleboard: Mat-formed wood particle board per ANSI 208.1, Grade 1-L-2 28–32 pounds per cubic foot.
  - a. Use particleboard made with binder containing no urea-formaldehyde resin.
2. Blocking: Provide mill option wood blocking in particleboard-core doors as required to eliminate through-bolting hardware for all surface applied hardware.
3. Adhesive: Type I bond.
4. Bonding: Fabricate doors using bonded core construction, including stile and rails bonded to core, using adhesive and pressure during the curing process. Plane assembled and cured door core units to a uniform thickness prior to application of crossbanding and veneers.
5. Crossbands: Dried to 6-9 percent moisture content, minimum 1/16-inch-thick spliced hardwood with no voids or defects, extending full width of doors with grain at right angles to face veneer.
6. Stiles: Provide SCL stiles, minimum 1-3/8-inch-thick before fitting; 1-1/8-inch minimum after trimming. For wood veneer doors, provide outer band matching specified wood veneer, with no exposed crossbands.
7. Rails: Provide wood rails, 1-1/8-inch minimum after trimming; mill option hardwood or softwood of a density equal to or exceeding Douglas Fir.
8. 20 minute particle core shall meet positive pressure and "S" label without use of intumescent seals.

## C. Identification: Stamp each door with NWWDA Certification Hallmark.

1. 20-Minute Fire Rated Doors: Provide each door with UL or WHI metal or mylar type labels.

## 2.6 FABRICATION – 45, 60 AND 90 MINUTE FIRE RATED DOORS

## A. Fabrication:

1. General: Fabricate as specified for standard doors, NWWDA IS 1.4, and UL requirements for fire rating shown.
2. Non-Ratable Openings: If any scheduled fire rated door cannot be labeled because of design, size, hardware, or other reason, give written notification; do not start fabrication until conflict is resolved.

## B. Core: Door manufacturer's standard non-combustible mineral core, containing 0-percent asbestos and designed to meet or exceed labeling requirements.

1. Concealed Rod Hardware: Where scheduled, provide Georgia-Pacific, or equal, Firestop components; including matching full length wood

edge meeting stiles with no visible finger joints, 1/2-inch width after trimming. Metal edges or metal edge and astragal no acceptable.

2. Reinforcement: Manufacturer's standard size, incombustible multi-ply inner blocking to eliminate through-bolting of surface mounted hardware.
  - a. Stile Edge Screw Withdrawal: Minimum 740-pounds when tested per ASTM D-1037.
3. Stile Edge Split Resistance: Minimum 750-pounds minimum when tested per ASTM D-143 (modified). For wood veneer doors, provide 1/2-inch-thick outer band matching specified wood veneer.
  - a. Reinforce hinge edge on all fire doors to accommodate full-mortise hinges as specified and to provide additional screw holding power when hinge is installed.
- C. Cross Bands and Edge Bands: Untreated or fire retardant treated per UL requirements for fire rating shown.
- D. Identification: Stamp each door with NWWDA Certification Hallmark.
  1. Fire Rated Doors: Provide each door with UL or WHI metal or mylar type labels.
- E. Install flush stainless steel edge guards under label procedure. Furnished by section 087100 – Door Hardware.
- F. Install Electro Lynx wiring and Molex. Type connectors under label procedure. Furnished by section 087100 – Door Hardware.

## 2.7 VISION PANEL FRAMES

- A. General: Provide where shown; square profile moldings, unless otherwise shown.
- B. Standard Doors:
  1. General: Solid stock hardwood; flush type, unless otherwise shown.
  2. Transparent Finish: Same grade and species to match face.
- C. Glazing Materials: Provided under Section 088000 – Glazing.

## 2.8 GLASS AND GLAZING

- A. Vision Glass: Rated and Non-rated vision glass specified in Section 088000 – Glazing.

## 2.9 SIZES AND CLEARANCES

- A. Sizes: As shown; coordinate with installation to determine actual door sizes and clearances.
  - 1. Door Thickness: 1-3/4-inch, unless otherwise shown.
- B. Clearances: Maximum 1/8-inch clearance at jambs, heads, and meeting stiles; maximum 1/4-inch clearance over thresholds, and maximum 3/8-inch clearance in openings without thresholds; unless otherwise shown. Bevel vertical edges 1/8-inch per 2 inches.

## 2.10 PRE-FITTING AND PREMACHINING

- A. General: Pre-fit and pre-machine.
- B. Pre-fitting: Pre-fit at factory per specified clearances. Provide stile edges with standard bevel or radius as required by hardware.
- C. Pre-machining: Coordinate with Section 087100 – Door Hardware, and DIVISION 26 - Electrical Security Requirements, including:
  - 1. Factory machine doors for hardware that is not surface applied. Locate hardware to comply with DHI-WDHS-3. Comply with final hardware schedules, door frame Shop Drawings, DHI A115-W Series standards, and hardware templates.
  - 2. Coordinate measurements of hardware mortises in metal frames to verify dimensions and alignment before factory machining.

## 2.11 PRESEALING FOR PAINTED FINISHES

- A. Opaque Finished Doors:
  - 1. General: Manufacturer's standard clear sealer or pigmented alkyd base primer sealer; verify compatibility with Section 099123 – Interior Painting.
  - 2. Sealer or Primer Sealer: One coat; apply to top and bottom rails and hardware cutouts.
  - 3. Opaque Finish: Shop or Field Paint as shown on Drawings and as specified in Section 099123 – Interior Painting.

## PART 3 - EXECUTION

### 3.1 PREPARATION

- A. General: Do not install doors until cementitious work in areas shown to receive wood doors is completed and dry.
- B. Environmental Requirements: Condition doors to normal occupancy conditions prior to hanging. Do not subject doors to abnormal heat, dryness, or humidity.



- D. Examine doors and substrates, with Installer present, for suitable conditions where wood doors will be installed.
  - 1. Verify that installed frames comply with indicated requirements for type, size, location, and swing characteristics and have been installed with plumb jambs and level heads.
  - 2. Reject doors with defects.
  - 3. Proceed with installation only after unsatisfactory conditions have been corrected.

### 3.2 INSTALLATION

- A. General: Cut, trim, and hang doors to fit into frames with specified clearances. Recoat top and bottom edges prior to hanging, if affected by fitting; use same type paint as applied at factory.
- B. Prefinished Doors: Cutting, trimming, fitting, and machining not permitted.
- C. Operation: Rehang or replace doors that do not swing or operate freely.
- E. Finished Doors: Replace doors that are damaged or do not comply with requirements. Doors may be repaired or refinished if work complies with requirements and shows no evidence of repair or refinishing.

END OF SECTION

**SECTION 087100 – DOOR HARDWARE**

## PART 1 - GENERAL

## 1.1 RELATED DOCUMENTS

- A. Drawings and general provisions of the Contract, including General and Supplementary Conditions and Division 1 Specification Sections, apply to this Section.

## 1.2 SUMMARY

- A. This Section includes commercial door hardware for the following:
  - 1. Swinging doors.
  - 2. Other doors to the extent indicated.
- B. Door hardware includes, but is not necessarily limited to, the following:
  - 1. Mechanical door hardware.
  - 2. Electromechanical door hardware.
- C. Related Sections:
  - 1. Division 08 Section "Hollow Metal Doors and Frames".
  - 2. Division 08 Section "Flush Wood Doors".
  - 3. Division 08 Section "Radiation Shielding Doors and Frames".
  - 4. Division 08 Section "Automatic Door Operators".
  - 5. Division 08 Section "Access Control Hardware".
- D. Codes and References: Comply with the version year adopted by the Authority Having Jurisdiction.
  - 1. ANSI A117.1 - Accessible and Usable Buildings and Facilities.
  - 2. ICC/IBC - International Building Code.
  - 3. NFPA 70 - National Electrical Code.
  - 4. NFPA 80 - Fire Doors and Windows.
  - 5. NFPA 101 - Life Safety Code.
  - 6. NFPA 105 - Installation of Smoke Door Assemblies.
  - 7. State Building Codes, Local Amendments.
- E. Standards: All hardware specified herein shall comply with the following industry standards:
  - 1. ANSI/BHMA Certified Product Standards - A156 Series
  - 2. UL10C – Positive Pressure Fire Tests of Door Assemblies

## 1.3 SUBMITTALS

- A. Product Data: Manufacturer's product data sheets including installation details, material descriptions, dimensions of individual components and profiles, operational descriptions and finishes.
- B. Door Hardware Schedule: Prepared by or under the supervision of supplier, detailing fabrication and assembly of door hardware, as well as procedures and diagrams. Coordinate the final Door Hardware Schedule with doors, frames, and related work to ensure proper size, thickness, hand, function, and finish of door hardware.
  - 1. Format: Comply with scheduling sequence and vertical format in DHI's "Sequence and Format for the Hardware Schedule."
  - 2. Organization: Organize the Door Hardware Schedule into door hardware sets indicating complete designations of every item required for each door or opening. Organize door hardware sets in same order as in the Door Hardware Sets at the end of Part 3. Submittals that do not follow the same format and order as the Door Hardware Sets will be rejected and subject to resubmission.
  - 3. Content: Include the following information:
    - a. Type, style, function, size, label, hand, and finish of each door hardware item.
    - b. Manufacturer of each item.
    - c. Fastenings and other pertinent information.
    - d. Location of door hardware set, cross-referenced to Drawings, both on floor plans and in door and frame schedule.
    - e. Explanation of abbreviations, symbols, and codes contained in schedule.
    - f. Mounting locations for door hardware.
    - g. Door and frame sizes and materials.
    - h. Warranty information for each product.
  - 4. Submittal Sequence: Submit the final Door Hardware Schedule at earliest possible date, particularly where approval of the Door Hardware Schedule must precede fabrication of other work that is critical in the Project construction schedule. Include Product Data, Samples, Shop Drawings of other work affected by door hardware, and other information essential to the coordinated review of the Door Hardware Schedule.
- C. Shop Drawings: Details of electrified access control hardware indicating the following:
  - 1. Wiring Diagrams: Upon receipt of approved schedules, submit detailed system wiring diagrams for power, signaling, monitoring, communication, and control of the access control system electrified hardware. Differentiate between manufacturer-installed and field-installed wiring. Include the following:
    - a. Elevation diagram of each unique access controlled opening showing location and interconnection of major system components with respect to their placement in the respective door openings.

- b. Complete (risers, point-to-point) access control system block wiring diagrams.
      - c. Wiring instructions for each electronic component scheduled herein.
    - 2. Electrical Coordination: Coordinate with related sections the voltages and wiring details required at electrically controlled and operated hardware openings.
  - D. Keying Schedule: After a keying meeting with the owner has taken place prepare a separate keying schedule detailing final instructions. Submit the keying schedule in electronic format. Include keying system explanation, door numbers, key set symbols, hardware set numbers and special instructions. Owner must approve submitted keying schedule prior to the ordering of permanent cylinders/cores.
  - E. Informational Submittals:
    - 1. Product Test Reports: Indicating compliance with cycle testing requirements, based on evaluation of comprehensive tests performed by manufacturer and witnessed by a qualified independent testing agency.
  - F. Operating and Maintenance Manuals: Provide manufacturers operating and maintenance manuals for each item comprising the complete door hardware installation in quantity as required in Division 01, Closeout Submittals.
- 1.4 QUALITY ASSURANCE
- A. Manufacturers Qualifications: Engage qualified manufacturers with a minimum 5 years of documented experience in producing hardware and equipment similar to that indicated for this Project and that have a proven record of successful in-service performance.
  - B. Installer Qualifications: A minimum 3 years documented experience installing both standard and electrified door hardware similar in material, design, and extent to that indicated for this Project and whose work has resulted in construction with a record of successful in-service performance.
  - C. Door Hardware Supplier Qualifications: Experienced commercial door hardware distributors with a minimum 5 years documented experience supplying both mechanical and electromechanical hardware installations comparable in material, design, and extent to that indicated for this Project. Supplier recognized as a factory direct distributor by the manufacturers of the primary materials with a warehousing facility in Project's vicinity. Supplier to have on staff a certified Architectural Hardware Consultant (AHC) available during the course of the Work to consult with Contractor, Architect, and Owner concerning both standard and electromechanical door hardware and keying.
  - D. Source Limitations: Obtain each type and variety of door hardware specified in this section from a single source unless otherwise indicated.
    - 1. Electrified modifications or enhancements made to a source manufacturer's product line by a secondary or third party source will not be accepted.

2. Provide electromechanical door hardware from the same manufacturer as mechanical door hardware, unless otherwise indicated.
- E. Each unit to bear third party permanent label demonstrating compliance with the referenced standards.
- F. conference to comply with requirements in Keying Conference: Conduct Division 01 Section "Project Meetings." Keying conference to incorporate the following criteria into the final keying schedule document:
1. Function of building, purpose of each area and degree of security required.
  2. Plans for existing and future key system expansion.
  3. Requirements for key control storage and software.
  4. Installation of permanent keys, cylinder cores and software.
  5. Address and requirements for delivery of keys.
- G. Pre-Submittal Conference: Conduct coordination conference in compliance with requirements in Division 01 Section "Project Meetings" with attendance by representatives of Supplier(s), Installer(s), and Contractor(s) to review proper methods and the procedures for receiving, handling, and installing door hardware.
1. Prior to installation of door hardware, conduct a project specific training meeting to instruct the installing contractors' personnel on the proper installation and adjustment of their respective products. Product training to be attended by installers of door hardware (including electromechanical hardware) for aluminum, hollow metal and wood doors. Training will include the use of installation manuals, hardware schedules, templates and physical product samples as required.
  2. Inspect and discuss electrical roughing-in, power supply connections, and other preparatory work performed by other trades.
  3. Review sequence of operation narratives for each unique access controlled opening.
  4. Review and finalize construction schedule and verify availability of materials.
  5. Review the required inspecting, testing, commissioning, and demonstration procedures
- H. At completion of installation, provide written documentation that components were applied to manufacturer's instructions and recommendations and according to approved schedule.
- 1.5 DELIVERY, STORAGE, AND HANDLING
- A. Inventory door hardware on receipt and provide secure lock-up and shelving for door hardware delivered to Project site. Do not store electronic access control hardware, software or accessories at Project site without prior authorization.
- B. Tag each item or package separately with identification related to the final Door Hardware Schedule, and include basic installation instructions with each item or package.

- C. Deliver, as applicable, permanent keys, cylinders, cores, access control credentials, software and related accessories directly to Owner via registered mail or overnight package service. Instructions for delivery to the Owner shall be established at the "Keying Conference".

#### 1.6 COORDINATION

- A. Templates: Obtain and distribute to the parties involved templates for doors, frames, and other work specified to be factory prepared for installing standard and electrified hardware. Check Shop Drawings of other work to confirm that adequate provisions are made for locating and installing hardware to comply with indicated requirements.
- B. Door Hardware and Electrical Connections: Coordinate the layout and installation of scheduled electrified door hardware and related access control equipment with required connections to source power junction boxes, low voltage power supplies, detection and monitoring hardware, and fire and detection alarm systems.
- C. Door and Frame Preparation: Doors and corresponding frames are to be prepared, reinforced and pre-wired (if applicable) to receive the installation of the specified electrified, monitoring, signaling and access control system hardware without additional in-field modifications.

#### 1.7 WARRANTY

- A. General Warranty: Reference Division 01, General Requirements. Special warranties specified in this Article shall not deprive Owner of other rights Owner may have under other provisions of the Contract Documents and shall be in addition to, and run concurrent with, other warranties made by Contractor under requirements of the Contract Documents.
- B. Warranty Period: Written warranty, executed by manufacturer(s), agreeing to repair or replace components of standard and electrified door hardware that fails in materials or workmanship within specified warranty period after final acceptance by the Owner. Failures include, but are not limited to, the following:
  - 1. Structural failures including excessive deflection, cracking, or breakage.
  - 2. Faulty operation of the hardware.
  - 3. Deterioration of metals, metal finishes, and other materials beyond normal weathering.
  - 4. Electrical component defects and failures within the systems operation.
- C. Standard Warranty Period: One year from date of Substantial Completion, unless otherwise indicated.
- D. Special Warranty Periods:
  - 1. Ten years for mortise locks and latches.
  - 2. Twenty five years for manual surface door closer bodies.
  - 3. Two years for electromechanical door hardware.

## 1.8 MAINTENANCE SERVICE

- A. Maintenance Tools and Instructions: Furnish a complete set of specialized tools and maintenance instructions as needed for Owner's continued adjustment, maintenance, and removal and replacement of door hardware.

## PART 2 - PRODUCTS

## 2.1 SCHEDULED DOOR HARDWARE

- A. General: Provide door hardware for each door to comply with requirements in Door Hardware Sets and each referenced section that products are to be supplied under.
- B. Designations: Requirements for quantity, item, size, finish or color, grade, function, and other distinctive qualities of each type of door hardware are indicated in the Door Hardware Sets at the end of Part 3. Products are identified by using door hardware designations, as follows:
  - 1. Named Manufacturer's Products: Product designation and manufacturer are listed for each door hardware type required for the purpose of establishing requirements. Manufacturers' names are abbreviated in the Door Hardware Schedule.
- C. Substitutions: Requests for substitution and product approval for inclusive mechanical and electromechanical door hardware in compliance with the specifications must be submitted in writing and in accordance with the procedures and time frames outlined in Division 01, Substitution Procedures. Approval of requests is at the discretion of the architect, owner, and their designated consultants.

## 2.2 HANGING DEVICES

- A. Hinges: ANSI/BHMA A156.1 certified butt hinges with number of hinge knuckles and other options as specified in the Door Hardware Sets.
  - 1. Quantity: Provide the following hinge quantity:
    - a. Two Hinges: For doors with heights up to 60 inches.
    - b. Three Hinges: For doors with heights 61 to 90 inches.
    - c. Four Hinges: For doors with heights 91 to 120 inches.
    - d. For doors with heights more than 120 inches, provide 4 hinges, plus 1 hinge for every 30 inches of door height greater than 120 inches.
  - 2. Hinge Size: Provide the following, unless otherwise indicated, with hinge widths sized for door thickness and clearances required:
    - a. Widths up to 3'0": 4-1/2" standard or heavy weight as specified.
    - b. Sizes from 3'1" to 4'0": 5" standard or heavy weight as specified.

3. Hinge Weight and Base Material: Unless otherwise indicated, provide the following:
  - a. Exterior Doors: Heavy weight, non-ferrous, ball bearing or oil impregnated bearing hinges unless Hardware Sets indicate standard weight.
  - b. Interior Doors: Standard weight, steel, ball bearing or oil impregnated bearing hinges unless Hardware Sets indicate heavy weight.
4. Hinge Options: Comply with the following:
  - a. Non-removable Pins: Provide set screw in hinge barrel that, when tightened into a groove in hinge pin, prevents removal of pin while door is closed; for the all out-swinging lockable doors.
5. Manufacturers:
  - a. Hager Companies (HA).
  - b. McKinney Products; ASSA ABLOY Architectural Door Accessories (MK).
  - c. Stanley Hardware (ST).
  - d. Ives (IV)

- B. Pin and Barrel Continuous Hinges: ANSI/BHMA A156.26 Grade 1-600 certified pin and barrel continuous hinges with minimum 14 gauge Type 304 stainless steel hinge leaves, concealed teflon coated stainless pin, and twin self lubricated nylon bearings at each knuckle separation. Factory trim hinges to suit door height and prepare for electrical cut-outs.

1. Manufacturers:
  - a. Hager Companies
  - b.

## 2.3 DOOR OPERATING TRIM

- A. Flush Bolts and Surface Bolts: ANSI/BHMA A156.3 and A156.16, Grade 1, certified.
1. Flush bolts to be furnished with top rod of sufficient length to allow bolt retraction device location approximately six feet from the floor.
  2. Furnish dust proof strikes for bottom bolts.
  3. Surface bolts to be minimum 8" in length and U.L. listed for labeled fire doors and U.L. listed for windstorm components where applicable.
  4. Provide related accessories (mounting brackets, strikes, coordinators, etc.) as required for appropriate installation and operation.
  5. Manufacturers:
    - a. Ives (IV).
    - b. Rockwood Products; ASSA ABLOY Architectural Door Accessories (RO).



- c. Trimco (TC).

## 2.4 CYLINDERS AND KEYING

- A. General: Cylinder manufacturer to have minimum (10) years experience designing secured master key systems and have on record a published security keying system policy.
- B. Source Limitations: Obtain each type of keyed cylinder and keys from the same source manufacturer as locksets and exit devices, unless otherwise indicated.
  - 1. Manufacturers:
    - a. Schlage (SC) – MATCH EXISTING.
- C. Cylinders: Original manufacturer cylinders complying with the following:
  - 1. Mortise Type: Threaded cylinders with rings and cams to suit hardware application.
  - 2. Rim Type: Cylinders with back plate, flat-type vertical or horizontal tailpiece, and raised trim ring.
  - 3. Bored-Lock Type: Cylinders with tailpieces to suit locks.
  - 4. Mortise and rim cylinder collars to be solid and recessed to allow the cylinder face to be flush and be free spinning with matching finishes.
  - 5. Keyway: Match Facility Standard. Everest C145
- D. Keying System: Each type of lock and cylinders to be factory keyed.
  - 1. Conduct specified "Keying Conference" to define and document keying system instructions and requirements.
  - 2. Furnish factory cut, nickel-silver large bow permanently inscribed with a visual key control number as directed by Owner.
  - 3. Existing System: Key locks to Owner's existing system.
- E. Key Quantity: Provide the following minimum number of keys:
  - 1. Change Keys per Cylinder: Two (2)
  - 2. Master Keys (per Master Key Level/Group): Five (5).
  - 3. Construction Keys (where required): Ten (10).
- F. Construction Keying: Provide construction master keyed cylinders.

## 2.5 MECHANICAL LOCKS AND LATCHING DEVICES

- A. Mortise Locksets, Grade 1 (Heavy Duty): ANSI/BHMA A156.13, Series 1000, Operational Grade 1 certified. Locksets are to be manufactured with a corrosion resistant steel case and be field-reversible for handing without disassembly of the lock body.
  - 1. Manufacturers:

- a. Schlage (SC) – L9000 Series.

## 2.6 LOCK AND LATCH STRIKES

- A. Strikes: Provide manufacturer's standard strike with strike box for each latch or lock bolt, with curved lip extended to protect frame, finished to match door hardware set, unless otherwise indicated, and as follows:
  1. Flat-Lip Strikes: For locks with three-piece antifriction latchbolts, as recommended by manufacturer.
  2. Extra-Long-Lip Strikes: For locks used on frames with applied wood casing trim.
  3. Aluminum-Frame Strike Box: Provide manufacturer's special strike box fabricated for aluminum framing.
  4. Double-lipped strikes: For locks at double acting doors. Furnish with retractable stop for rescue hardware applications.
- B. Standards: Comply with the following:
  1. Strikes for Mortise Locks and Latches: BHMA A156.13.
  2. Strikes for Bored Locks and Latches: BHMA A156.2.
  3. Strikes for Auxiliary Deadlocks: BHMA A156.36.
  4. Dustproof Strikes: BHMA A156.16.

## 2.7 ELECTRIC STRIKES

- A. Standard Electric Strikes: Heavy duty, cylindrical and mortise lock electric strikes conforming to ANSI/BHMA A156.31, Grade 1, UL listed for both Burglary Resistance and for use on fire rated door assemblies. Stainless steel construction with dual interlocking plunger design tested to exceed 3000 lbs. of static strength and 350 ft-lbs. of dynamic strength. Strikes tested for a minimum 1 million operating cycles. Provide strikes with 12 or 24 VDC capability and supplied standard as fail-secure unless otherwise specified. Provide latchbolt and latchbolt strike monitoring indicating both the position of the latchbolt and locked condition of the strike where specified.
  1. Manufacturers:
    - a. HES (HS).
    - b. Security Door Controls (SD).

## 2.8 DOOR CLOSERS

- A. All door closers specified herein shall meet or exceed the following criteria:
  1. General: Door closers to be from one manufacturer, matching in design and style, with the same type door preparations and templates regardless of application or spring size. Closers to be non-handed with full sized covers including installation and adjusting information on inside of cover.

2. Standards: Closers to comply with UL-10C for Positive Pressure Fire Test and be U.L. listed for use of fire rated doors.
  3. Cycle Testing: Provide closers which have surpassed 15 million cycles in a test witnessed and verified by UL.
  4. Size of Units: Comply with manufacturer's written recommendations for sizing of door closers depending on size of door, exposure to weather, and anticipated frequency of use. Where closers are indicated for doors required to be accessible to the physically handicapped, provide units complying with ANSI ICC/A117.1.
  5. Closer Arms: Provide heavy duty, forged steel closer arms unless otherwise indicated in Hardware Sets.
  6. Closers shall not be installed on exterior or corridor side of doors; where possible install closers on door for optimum aesthetics.
  7. Closer Accessories: Provide door closer accessories including custom templates, special mounting brackets, spacers and drop plates as required for proper installation. Provide through-bolt and security type fasteners as specified in the hardware sets.
- B. Door Closers, Surface Mounted (Large Body Cast Iron): ANSI/BHMA A156.4, Grade 1 surface mounted, heavy duty door closers with complete spring power adjustment, sizes 1 thru 6; and fully operational adjustable according to door size, frequency of use, and opening force. Closers to be rack and pinion type, one piece cast iron body construction, with adjustable backcheck and separate non-critical valves for closing sweep and latch speed control. Thru bolt mounting
1. Manufacturers:
    - a. LCN Closers (LC) - 4011/4111 Series

## 2.9 ARCHITECTURAL TRIM

### A. Door Protective Trim

1. General: Door protective trim units to be of type and design as specified below or in the Hardware Sets.
2. Size: Fabricate protection plates (kick, armor, or mop) not more than 2" less than door width (LDW) on stop side of single doors and 1" LDW on stop side of pairs of doors, and not more than 1" less than door width on pull side. Coordinate and provide proper width and height as required where conflicting hardware dictates. Height to be as specified in the Hardware Sets.
3. Where plates are applied to fire rated doors with the top of the plate more than 16" above the bottom of the door, provide plates complying with NFPA 80. Consult manufacturer's catalog and template book for specific requirements for size and applications.

4. Protection Plates: ANSI/BHMA A156.6 certified protection plates (kick, armor, or mop), fabricated from the following:
  - a. Stainless Steel: 300 grade, 050-inch thick.
5. Options and fasteners: Provide manufacturer's designated fastener type as specified in the Hardware Sets. Provide countersunk screw holes.
6. Manufacturers:
  - a. Ives, Inc. (IV).
  - b. Rockwood Products; ASSA ABLOY Architectural Door Accessories (RO).
  - c. Trimco (TC).

## 2.10 DOOR STOPS AND HOLDERS

- A. General: Door stops and holders to be of type and design as specified below or in the Hardware Sets.
- B. Door Stops and Bumpers: ANSI/BHMA A156.16, Grade 1 certified door stops and wall bumpers. Provide wall bumpers, either convex or concave types with anchorage as indicated, unless floor or other types of door stops are specified in Hardware Sets. Do not mount floor stops where they will impede traffic. Where floor or wall bumpers are not appropriate, provide overhead type stops and holders.
  1. Manufacturers:
    - a. Hager, Inc. (HA).
    - b. Rockwood Products; ASSA ABLOY Architectural Door Accessories (RO).
    - c. Trimco (TC).

## 2.11 ARCHITECTURAL SEALS

- A. General: Thresholds, weatherstripping, and gasket seals to be of type and design as specified below or in the Hardware Sets. Provide continuous weatherstrip gasketing on exterior doors and provide smoke, light, or sound gasketing on interior doors where indicated. At exterior applications provide non-corrosive fasteners and elsewhere where indicated.
- B. Smoke Labeled Gasketing: Assemblies complying with NFPA 105 that are listed and labeled by a testing and inspecting agency acceptable to authorities having jurisdiction, for smoke control ratings indicated, based on testing according to UL 1784.
  1. Provide smoke labeled perimeter gasketing at all smoke labeled openings.
- C. Fire Labeled Gasketing: Assemblies complying with NFPA 80 that are listed and labeled by a testing and inspecting agency acceptable to authorities having jurisdiction, for fire ratings indicated, based on testing according to UL-10C.

1. Provide intumescent seals as indicated to meet UL10C Standard for Positive Pressure Fire Tests of Door Assemblies, and NFPA 252, Standard Methods of Fire Tests of Door Assemblies.
- D. Sound-Rated Gasketing: Assemblies that are listed and labeled by a testing and inspecting agency, for sound ratings indicated.
- E. Replaceable Seal Strips: Provide only those units where resilient or flexible seal strips are easily replaceable and readily available from stocks maintained by manufacturer.
- F. Manufacturers:
1. National Guard Products (NG).
  2. Pemko Products; ASSA ABLOY Architectural Door Accessories (PE).
  3. Reese Enterprises, Inc. (RE).

## 2.12 FABRICATION

- A. Fasteners: Provide door hardware manufactured to comply with published templates generally prepared for machine, wood, and sheet metal screws. Provide screws according to manufacturers recognized installation standards for application intended.

## 2.13 FINISHES

- A. Standard: Designations used in the Hardware Sets and elsewhere indicate hardware finishes complying with ANSI/BHMA A156.18, including coordination with traditional U.S. finishes indicated by certain manufacturers for their products.
- B. Provide quality of finish, including thickness of plating or coating (if any), composition, hardness, and other qualities complying with manufacturer's standards, but in no case less than specified by referenced standards for the applicable units of hardware
- C. Protect mechanical finishes on exposed surfaces from damage by applying a strippable, temporary protective covering before shipping.

## PART 3 - EXECUTION

### 3.1 EXAMINATION

- A. Examine scheduled openings, with Installer present, for compliance with requirements for installation tolerances, labeled fire door assembly construction, wall and floor construction, and other conditions affecting performance.
- B. Notify architect of any discrepancies or conflicts between the door schedule, door types, drawings and scheduled hardware. Proceed only after such discrepancies or conflicts have been resolved in writing.

## 3.2 PREPARATION

- A. Hollow Metal Doors and Frames: Comply with ANSI/DHI A115 series.
- B. Wood Doors: Comply with ANSI/DHI A115-W series.

## 3.3 INSTALLATION

- A. Install each item of mechanical and electromechanical hardware and access control equipment to comply with manufacturer's written instructions and according to specifications.
  - 1. Installers are to be trained and certified by the manufacturer on the proper installation and adjustment of fire, life safety, and security products including: hanging devices; locking devices; closing devices; and seals.
- B. Mounting Heights: Mount door hardware units at heights indicated in following applicable publications, unless specifically indicated or required to comply with governing regulations:
  - 1. Standard Steel Doors and Frames: DHI's "Recommended Locations for Architectural Hardware for Standard Steel Doors and Frames."
  - 2. Wood Doors: DHI WDHS.3, "Recommended Locations for Architectural Hardware for Wood Flush Doors."
  - 3. Where indicated to comply with accessibility requirements, comply with ANSI A117.1 "Accessibility Guidelines for Buildings and Facilities."
  - 4. Provide blocking in drywall partitions where wall stops or other wall mounted hardware is located.
- C. Retrofitting: Install door hardware to comply with manufacturer's published templates and written instructions. Where cutting and fitting are required to install door hardware onto or into surfaces that are later to be painted or finished in another way, coordinate removal, storage, and reinstallation of surface protective trim units with finishing work specified in Division 9 Sections. Do not install surface-mounted items until finishes have been completed on substrates involved.
- D. Thresholds: Set thresholds for exterior and acoustical doors in full bed of sealant complying with requirements specified in Division 7 Section "Joint Sealants."
- E. Storage: Provide a secure lock up for hardware delivered to the project but not yet installed. Control the handling and installation of hardware items so that the completion of the work will not be delayed by hardware losses before and after installation.

## 3.4 FIELD QUALITY CONTROL

- A. Field Inspection: Supplier will perform a final inspection of installed door hardware and state in report whether work complies with or deviates from requirements, including whether door hardware is properly installed, operating and adjusted.

## 3.5 ADJUSTING

- A. Initial Adjustment: Adjust and check each operating item of door hardware and each door to ensure proper operation or function of every unit. Replace units that cannot be adjusted to operate as intended. Adjust door control devices to compensate for final operation of heating and ventilating equipment and to comply with referenced accessibility requirements.

## 3.6 CLEANING AND PROTECTION

- A. Protect all hardware stored on construction site in a covered and dry place. Protect exposed hardware installed on doors during the construction phase. Install any and all hardware at the latest possible time frame.
- B. Clean adjacent surfaces soiled by door hardware installation.
- C. Clean operating items as necessary to restore proper finish. Provide final protection and maintain conditions that ensure door hardware is without damage or deterioration at time of owner occupancy.

## 3.7 DEMONSTRATION

- A. Instruct Owner's maintenance personnel to adjust, operate, and maintain mechanical and electromechanical door hardware.

## 3.8 DOOR HARDWARE SETS

- A. The hardware sets represent the design intent and direction of the owner and architect. They are a guideline only and should not be considered a detailed hardware schedule. Discrepancies, conflicting hardware and missing items should be brought to the attention of the architect with corrections made prior to the bidding process. Omitted items not included in a hardware set should be scheduled with the appropriate additional hardware required for proper application and functionality.
- B. The supplier is responsible for handing and sizing all products and providing the correct option for the appropriate door type and material where more than one is presented in the hardware sets. Quantities listed are for each pair of doors, or for each single door.
- C. Manufacturer's Abbreviations:
  - 1. IV - Ives
  - 2. RF - Rixson
  - 3. RO - Rockwood

- 4. SC – Schlage
- 5. VD – Von Duprin
- 6. SD - Security Door Controls
- 7. LC - LCN Closers
- 8. PE – Pemko
- 9. HA – Hager
- 10. ST – Stanley

**Hardware Sets**

**Set: 1.0**

Doors: A402, A404, A405

3 Hinges	5BB1 4 ½" x 4 ½"	626	IV
1 Mortise Lock (Office)	L9050P6 17B	626	SC
1 Cylinder (mortise)	30-138	626	SC
1 Stop	236W	US26D	HA
1 Gasketing	S88BL		PE

END OF SECTION 087100



**SECTION 088000 – GLAZING****PART 1 - GENERAL****1.1 SUMMARY**

- A. Furnish labor, materials, tools, equipment, and services for Interior Glass and Glazing in accordance with provisions of Contract Documents.
- B. Completely coordinate with work of other trades.

**1.2 QUALITY ASSURANCE**

- A. Glass Standards:
  - 1. ANSI Z97.1.
  - 2. CPSC 16 CFR 1201.
  - 3. GANA Glazing Manual.
- B. Flat Glass ASTM C1036.
  - 1. Float glass: Type I, Quality q3 and Class 1 unless otherwise indicated.
  - 2. Figured glass: Type II, Quality q7, Form 3 and Class 1, Finish f1 and Pattern p2 unless otherwise indicated.
  - 3. Mirror glass and one-way vision glass: Type I, Quality q1 or q2, Class 1 and coated for purpose.
- C. Flat Glass, Heat Treated, Coated and Uncoated, ASTM C1048.
  - 1. Heat strengthened glass: Kind HS, Type I, Quality q3, Class 1 and Condition A unless otherwise indicated.
  - 2. Tempered glass: Kind FT, Type I, Quality q3, Class 1 and Condition A unless otherwise indicated.
- D. Mirror Glass:
  - 1. ASTM C1503;
  - 2. Quality: Mirror select.
  - 3. F.S.DD-M-00411B (1).
- E. Fire-Rated Assemblies:
  - 1. General:
    - a. Where glazing products are used in fire-rated assemblies, comply with requirements of specific assembly specified in other sections of these Specifications.
    - b. Underwriters Laboratories, Inc. (UL):
      - 1) UL 9 – Fire Tests of Window Assemblies.
      - 2) UL 10B – Fire Tests of Door Assemblies.
      - 3) UL 10C – Positive Pressure Fire Tests of Door Assemblies.
    - c. Fire Protective Rated Glass: Each lite shall bear permanent, non-removable label of UL certifying it for use in tested and rated fire protective assemblies.
  - 2. Door Assemblies:
    - a. Complying with NFPA 80 and listed and labeled by a testing and inspecting agency acceptable to authorities having jurisdiction, for fire ratings indicated, based on testing according to NFPA 252.
    - b. Positive Pressure Compliance: UL 10C.
    - c. Fire Protective Glazing Products for Door Assemblies: Products identical to those tested per UL 10B, labeled and listed by UL.

3. Window Assemblies:
  - a. Complying with NFPA 80 that are listed and labeled by a testing and inspecting agency acceptable to authorities having jurisdiction, for fire ratings indicated, based on testing according to NFPA 257.
  - b. Positive Pressure Compliance: UL 10C.
- F. Laminated Glass:
  1. ASTM C1172 Standard Specification for Laminated Architectural Flat Glass.
  2. Laminated Glass Design Guide, by the Glass Association of North America (GANA).
- G. Glazing Standards:
  1. Glazing Manual, by the Glass Association of North America (GANA).

### 1.3 SUBMITTALS

- A. Samples:
  1. Provide one (1) 12 IN x 12 IN example of each specified type of glass.
- B. Contract Closeout Information:
  1. Warranties.
- C. Smoke baffle system:
  1. Shop drawing details, plans and elevations showing supports to building structure, interface at ceiling, blocking, baffle shoe, cap rail, grommet, cladding, sealant/adhesive, and glass.
  2. Product data.
  3. Standard warranty.
  4. Installation Instructions

### 1.4 WARRANTY

- A. Written warranty signed by manufacturer or fabricator.
- B. Laminated Glass:
  1. Five (5) years against deterioration including edge separation, delamination that materially obstructs vision through glass, and blemishes exceeding those allowed by referenced laminated-glass standard.
- C. Fire-rated Ceramics:
  1. Five (5) year manufacturer's standard warranty.

## PART 2 - PRODUCTS

### 2.1 ACCEPTABLE MANUFACTURERS

- A. Glass Products:
  1. Base:
    - a. AGC Industries.
    - b. Other manufacturers listed under (GLI) on Interior Finish Schedule drawing I-001
  2. Optional:
    - a. Guardian Industries.
    - b. Pilkington.
    - c. PPG Industries.
    - d. Saint-Gobain.
- B. Fire-rated Glass Ceramic:
  1. Base:

- a. Technical Glass Products.
2. Optional:
  - a. Saffi First.
  - b. Pilkington.
  - c. Saint-Gobain.
- C. Radiation-resistant Glass:
  1. Base:
    - a. Ray-Bar Engineering Corp.
  2. Optional:
    - a. Nelco.
    - b. Corning Inc.
    - c. Schott North America, Inc.
    - d. Radiation Protection Products (RPP).

## 2.2 MATERIALS

- A. Glass Materials:
  1. Comply with indicated standards.
  2. See Glass Types Schedule for listing of types.
  3. Materials specified in Glass Types Schedules are minimum acceptable products.
  4. Single manufacturer produce individual glass types used in fabrication of insulating units.
  5. Manufacturer or fabricator determine if materials should be heat strengthened or fully tempered at non-hazardous locations that do not require safety glazing and provide accordingly.
- B. Glazing Compounds:
  1. Nonsag, nonstain type.
  2. Pigmented to match frame units not requiring painting.
  3. Compatible with adjacent surfaces.
  4. For use in setting glass: Neutral-cure Silicone sealant.
  5. Sealants:
    - a. Sealants shall have a VOC content no greater than 250 g/L.
    - b. Sealants shall contain no carcinogen or reproductive toxicant components present at more than 1% of total mass of the product as defined in the California Office of Environmental Health Hazard Assessment's (OEHHA) list entitled "Chemicals Known to the State to Cause Cancer" or the Reproductive Toxicity, Safe Drinking Water and Toxic Enforcement Act of 1986 (Proposition 65).
  6. Sealant tape:
    - a. Butyl rubber sealant tape or ribbon having a continuous neoprene shim.
  7. Gaskets:
    - a. Polyvinyl chloride or neoprene.
    - b. Extruded, flexible, of profile and hardness required to receive glass and provide a watertight installation.
- C. Installation Setting Blocks and Spacers:
  1. Neoprene, compatible with sealants used.
  2. Setting blocks: 80-90 durometer.
  3. Spacers: 40-50 durometer.
  4. Compressible filler stock: Closed cell jacketed rod stock of synthetic rubber or plastic foam.
  5. Shims, clips, springs, angles, beads, attachment screws and other miscellaneous items: As indicated or required.

## 2.3 GLASS TYPES SCHEDULE

- A. Refer to Interior Glass Types Schedule and Interior Finish Schedule for basic description of Mark Numbers indicated on Drawing.
- B. Refer to Drawings for depiction of unit sizes and locations.
- C. Upgrade basic type conditions in accordance with following rules:
  - 1. Heat treatment upgrade based on physical size of unit:
    - a. Heat strengthened or fully tempered units between 55 and 70 SF.
    - b. Fully temper units exceeding 70 SF.
    - c. Strengthen annealed glass where units exceed length or width limitations or both as recommended by glass manufacturer.
  - 2. Heat treatment upgrade based on locations which are potentially hazardous to occupants:
    - a. Upgrade units to fully tempered, Kind FT, glass as required by any one of following:
      - 1) When required by local Codes.
      - 2) When specifically indicated on Drawings.
      - 3) Locations requiring Safety Glass, Kind FT, by 16 CFR 1201 and ANSI Z97.1:
        - a) Units installed in doors, sash, transom or other operable units.
        - b) Units where any part of unit is within 18 IN, measured vertically, above a floor line, sidewalk, paver, or other walking surface located within 3 FT of the glass unit, measured horizontally.
      - 4) Units in sidelights and other units located adjacent to and within 48 IN of either jamb of door or other operable units; this includes adjacent lites that are in perpendicular plane to door.
  - 3. Other conditions requiring heat treatment upgrades:
    - a. Units which will be exposed to irregular sun or shade combinations or both shall be Kind HS or better.
    - b. Where glass manufacturer recommends heat treatment coatings or tints specified.
    - c. Where required to resist lateral loads.

## 2.4 INTERIOR GLASS TYPES

- A. Annealed:**
  - 1. Clear float, 6mm (1/4 IN) thick.
- B. Tempered:**
  - 1. Clear, fully-tempered tongue-less float, 6mm (1/4 IN) thick.
- C. Laminated Fire and Safety Glass, 8mm:**
  - 1. Laminated, wireless, UL labeled for assembly indicated.
  - 2. Impact-Safety Rated per ANSI Z97.1 and CPSC 16CFR1201.
  - 3. Thickness: 8mm (5/16 IN), laminated.
  - 4. Surface: Polished.
  - 5. Base Product: FireLite Plus by Technical Glass Products.
- D. Mirror Glass:**
  - 1. Color: Clear.
  - 2. Thickness: 6mm (1/4 IN).
  - 3. Unit Length and Width: As indicated on drawings.
  - 4. Annealed
  - 5. Tempered.

**E. Radiation-Resistant Glazing:**

1. Composition: Lead-barium, polished float glass containing not less than 60 percent heavy metal oxides, including not less than 48 percent lead oxide by weight.
2. Color: Clear.
3. Provide glass units of sufficient thickness to provide same radiation shielding as adjacent wall areas. Provide single or multiple plies as necessary.

**F. Laminated, Heat-Strengthened Glass:**

1. Laminated safety glass complying with ANSI Z97.1 and CPSC 16 CFR 1201, consisting of 2 sheets of heat strengthened float glass ASTM C1036, and 60 mil interlayer.

**2.5 EXTERIOR GLASS TYPES****A. Insulated Glazing:**

- a. Manufacturers: Subject to compliance with requirements, provide the following:
  - 1) **PPG Solarban 60 (2) Starphire + Starphire Match Existing**
- b. Insulating-Glass Units: Factory-assembled units consisting of sealed lites of glass separated by a dehydrated interspace, qualified according to ASTM E 2190, and complying with other requirements specified.
  - 1) Sealing System: Dual seal, with manufacturer's standard primary and secondary.
  - 2) Desiccant: Molecular sieve or silica gel, or blend of both.

**PART 3 - EXECUTION****3.1 INSPECTION**

- A. Examine framing or glazing channel surfaces, backing, stop design, and conditions under which glazing is to be installed.

**3.2 INSTALLATION**

- A. Do not install glass with edge damage.
- B. Contractor is responsible for correct glass size for each opening, within tolerances and dimensions established.
- C. Comply with recommendations of manufacturers, except where more stringent requirements are indicated.
- D. Comply with GANA Glazing Manual.
- E. Install sealants as recommended by sealant manufacturer.
- F. Install setting blocks in adhesive or sealant.
- G. Provide spacers inside and out, of proper size and spacing, for glass size, except where gaskets are used for glazing.
- H. Minimum Bite:
  1. Monolithic, 6mm (1/4 IN) glass: 3/8 IN minimum bite.
  2. For other sizes: Refer to Table C of AAMA's Aluminum Curtain Wall Design Manual, Volume 6, Glass and Glazing.
- I. Sealant Depth: Equal to sealant width.
- J. Prevent sealant exudation from glazing channels.
  1. Leave void at heel or install filler at jambs and head.
  2. Do not leave void or install filler at sill.

- K. Miter cut and bond gasket ends together at corners.
- L. Immediately after installation, attach crossed streamers to framing held away from glass.
- M. Do not apply anything to surfaces of glass.
- N. Install spandrel units from exterior of building.
- O. Installation of Mirrors:
  - 1. Mastic Attachment: Install mirrors with mirror adhesive applied to back of mirror and pressed against substrate as recommended by mirror supplier.
- P. Remove and replace damaged glass.
- Q. Installation smoke baffle systems:
  - 1. Install in accordance with approved shop drawings.
  - 2. Follow manufacturers installation instructions.

### **3.3 CLEANING AND PROTECTION**

- A. Wash and polish glass on both faces not more than 7 days prior to final completion of work in each area.
- B. Comply with glass manufacturer's recommendations and GANA 01-0300.

**END OF SECTION**

**SECTION 092216 - NON-STRUCTURAL METAL FRAMING**

## PART 1 - GENERAL

## 1.1 RELATED DOCUMENTS

- A. Drawings and general provisions of the Contract, including General and Supplementary Conditions and Division 01 Specification Sections, apply to this Section.

## 1.2 SUMMARY

- A. Section Includes:
  - 1. Non-load-bearing steel framing systems for interior gypsum board assemblies.
  - 2. Suspension systems for interior gypsum ceilings, soffits, and grid systems.
- B. Related Requirements:
  - 1. Section 054000 "Cold-Formed Metal Framing" for exterior and interior load-bearing and exterior non-load-bearing wall studs; floor joists; roof rafters and ceiling joists; and roof trusses.

## 1.3 SUBMITTALS

- A. Product Data: For each type of product.

## PART 2 - PRODUCTS

## 2.1 PERFORMANCE REQUIREMENTS

- A. Fire-Test-Response Characteristics: For fire-resistance-rated assemblies that incorporate non-load-bearing steel framing, provide materials and construction identical to those tested in assembly indicated, according to ASTM E 119 by an independent testing agency.
- B. STC-Rated Assemblies: For STC-rated assemblies, provide materials and construction identical to those tested in assembly indicated, according to ASTM E 90 and classified according to ASTM E 413 by an independent testing agency.

## 2.2 FRAMING SYSTEMS

- A. Framing Members, General: Comply with ASTM C 754 for conditions indicated.
  - 1. Steel Sheet Components: Comply with ASTM C 645 requirements for metal unless otherwise indicated.
  - 2. Protective Coating: ASTM A 653/A 653M, G40 (Z120) hot-dip galvanized unless otherwise indicated.

- B. Studs and Runners: ASTM C 645. Use either steel studs and runners or dimpled steel studs and runners.
1. Steel Studs and Runners (or Dimpled Steel Studs and Runners):
    - a. Thickness: 33 Mil (structural) for floor to floor height of 16'-0" or less and use 54 Mil studs for more than 16'-0"; minimum, unless noted otherwise. **Use 16 GA studs at lead lined walls** unless noted otherwise.
    - b. Depth: As indicated on Drawings.
- C. Slip-Type Head Joints: Where indicated, provide one of the following:
1. Single Long-Leg Runner System: ASTM C 645 top runner with 2-inch- (51-mm-) deep flanges in thickness not less than indicated for studs, installed with studs friction fit into top runner and with continuous bridging located within 12 inches (305 mm) of the top of studs to provide lateral bracing.
  2. Deflection Track: Steel sheet top runner manufactured to prevent cracking of finishes applied to interior partition framing resulting from deflection of structure above; in thickness not less than indicated for studs and in width to accommodate depth of studs.
- D. Flat Strap and Backing Plate: Steel sheet for blocking and bracing in length and width indicated.
1. Minimum Base-Metal Thickness: As indicated on Drawings.
- E. Cold-Rolled Channel Bridging: Steel, 0.053-inch (1.34-mm) minimum base-metal thickness, with minimum 1/2-inch- (13-mm-) wide flanges.
1. Depth: 1-1/2 inches (38 mm).
  2. Clip Angle: Not less than 1-1/2 by 1-1/2 inches (38 by 38 mm), 0.068-inch- (1.72-mm-) thick, galvanized steel.
- F. Hat-Shaped, Rigid Furring Channels: ASTM C 645.
1. Minimum Base-Metal Thickness: 0.033 inch (0.84 mm).
  2. Depth: 7/8 inch (22.2 mm).
- G. Resilient Furring Channels: 1/2-inch- (13-mm-) deep, steel sheet members designed to reduce sound transmission.
1. Configuration: hat shaped.
- H. Cold-Rolled Furring Channels: 0.053-inch (1.34-mm) uncoated-steel thickness, with minimum 1/2-inch- (13-mm-) wide flanges.
1. Depth: 3/4 inch (19 mm).
  2. Furring Brackets: Adjustable, corrugated-edge type of steel sheet with minimum uncoated-steel thickness of 0.033 inch (0.8 mm).
  3. Tie Wire: ASTM A 641/A 641M, Class 1 zinc coating, soft temper, 0.062-inch- (1.59-mm-) diameter wire, or double strand of 0.048-inch- (1.21-mm-) diameter wire.

## 2.3 SUSPENSION SYSTEMS

- A. Tie Wire: ASTM A 641/A 641M, Class 1 zinc coating, soft temper, 0.062-inch- (1.59-mm-) diameter wire, or double strand of 0.048-inch- (1.21-mm-) diameter wire.
- B. Hanger Attachments to Concrete:



1. Anchors: Fabricated from corrosion-resistant materials with holes or loops for attaching wire hangers and capable of sustaining, without failure, a load equal to 5 times that imposed by construction as determined by testing according to ASTM E 488 by an independent testing agency.
    - a. Type: Post-installed, expansion anchor.
  2. Powder-Actuated Fasteners: Suitable for application indicated, fabricated from corrosion-resistant materials with clips or other devices for attaching hangers of type indicated, and capable of sustaining, without failure, a load equal to 10 times that imposed by construction as determined by testing according to ASTM E 1190 by an independent testing agency.
- C. Wire Hangers: ASTM A 641/A 641M, Class 1 zinc coating, soft temper, 0.16 inch (4.12 mm) in diameter.
- D. Carrying Channels: Cold-rolled, commercial-steel sheet with a base-metal thickness of 0.053 inch (1.34 mm) and minimum 1/2-inch- (13-mm-) wide flanges.
  1. Depth: 1-1/2 inches (38 mm).
- E. Furring Channels (Furring Members):
  1. Cold-Rolled Channels: 0.053-inch (1.34-mm) uncoated-steel thickness, with minimum 1/2-inch- (13-mm-) wide flanges, 3/4 inch (19 mm) deep.
  2. Steel Studs and Runners: ASTM C 645.
    - a. Minimum Base-Metal Thickness: 0.033 inch (0.84 mm), unless noted otherwise.
    - b. Depth: 1-5/8 inches (41 mm) unless noted otherwise.
  3. Hat-Shaped, Rigid Furring Channels: ASTM C 645, 7/8 inch (22 mm) deep.
    - a. Minimum Base-Metal Thickness: 0.033 inch (0.84 mm).
  4. Resilient Furring Channels: 1/2-inch- (13-mm-) deep members designed to reduce sound transmission.
    - a. Configuration: hat shaped.
- F. Grid Suspension System for Gypsum Board Ceilings: ASTM C 645, direct-hung system composed of main beams and cross-furring members that interlock.
  1. Products: Subject to compliance with requirements, provide one of the following:
    - a. Armstrong World Industries, Inc.; Drywall Grid Systems.
    - b. Chicago Metallic Corporation; Drywall Grid System.
    - c. USG Corporation; Drywall Suspension System.

## 2.4 AUXILIARY MATERIALS

- A. General: Provide auxiliary materials that comply with referenced installation standards.
1. Fasteners for Metal Framing: Of type, material, size, corrosion resistance, holding power, and other properties required to fasten steel members to substrates.

## PART 3 - EXECUTION

## 3.1 EXAMINATION

- A. Examine areas and substrates, with Installer present, and including welded hollow-metal frames, cast-in anchors, and structural framing, for compliance with requirements and other conditions affecting performance of the Work.
- B. Proceed with installation only after unsatisfactory conditions have been corrected.

## 3.2 PREPARATION

- A. Suspended Assemblies: Coordinate installation of suspension systems with installation of overhead structure to ensure that inserts and other provisions for anchorages to building structure have been installed to receive hangers at spacing required to support the Work and that hangers will develop their full strength.
  - 1. Furnish concrete inserts and other devices indicated to other trades for installation in advance of time needed for coordination and construction.

## 3.3 INSTALLATION, GENERAL

- A. Installation Standard: ASTM C 754.
  - 1. Gypsum Plaster Assemblies: Also comply with requirements in ASTM C 841 that apply to framing installation.
  - 2. Portland Cement Plaster Assemblies: Also comply with requirements in ASTM C 1063 that apply to framing installation.
  - 3. Gypsum Veneer Plaster Assemblies: Also comply with requirements in ASTM C 844 that apply to framing installation.
  - 4. Gypsum Board Assemblies: Also comply with requirements in ASTM C 840 that apply to framing installation.
- B. Install supplementary framing, and blocking to support fixtures, equipment services, heavy trim, grab bars, toilet accessories, furnishings, or similar construction.
- C. Install bracing at terminations in assemblies.
- D. Do not bridge building control and expansion joints with non-load-bearing steel framing members. Frame both sides of joints independently.

## 3.4 INSTALLING FRAMED ASSEMBLIES

- A. Install framing system components according to spacings indicated, but not greater than spacings required by referenced installation standards for assembly types.
  - 1. Single-Layer Application: 16 inches (406 mm) o.c. unless otherwise indicated.
  - 2. Multilayer Application: 16 inches (406 mm) o.c. unless otherwise indicated.
  - 3. Tile Backing Panels: 16 inches (406 mm) o.c. unless otherwise indicated.

- B. Where studs are installed directly against exterior masonry walls or dissimilar metals at exterior walls, install isolation strip between studs and exterior wall.
- C. Install studs so flanges within framing system point in same direction.
- D. Install tracks (runners) at floors and overhead supports. Extend framing full height to structural supports or substrates above suspended ceilings except where partitions are indicated to terminate at suspended ceilings. Continue framing around ducts penetrating partitions above ceiling.
  - 1. Slip-Type Head Joints: Where framing extends to overhead structural supports, install to produce joints at tops of framing systems that prevent axial loading of finished assemblies.
  - 2. Door Openings: Screw vertical studs at jambs to jamb anchor clips on door frames; install runner track section (for cripple studs) at head and secure to jamb studs.
    - a. Install two studs at each jamb unless otherwise indicated.
    - b. Install cripple studs at head adjacent to each jamb stud, with a minimum 1/2-inch (13-mm) clearance from jamb stud to allow for installation of control joint in finished assembly.
    - c. Extend jamb studs through suspended ceilings and attach to underside of overhead structure.
  - 3. Other Framed Openings: Frame openings other than door openings the same as required for door openings unless otherwise indicated. Install framing below sills of openings to match framing required above door heads.
  - 4. Fire-Resistance-Rated Partitions: Install framing to comply with fire-resistance-rated assembly indicated and support closures and to make partitions continuous from floor to underside of solid structure.
    - a. Firestop Track: Where indicated, install to maintain continuity of fire-resistance-rated assembly indicated.
  - 5. Sound-Rated Partitions: Install framing to comply with sound-rated assembly indicated.
  - 6. Curved Partitions:
    - a. Bend track to uniform curve and locate straight lengths so they are tangent to arcs.
    - b. Begin and end each arc with a stud, and space intermediate studs equally along arcs. On straight lengths of no fewer than two studs at ends of arcs, place studs 6 inches (150 mm) o.c.
- E. Direct Furring:
  - 1. Screw to wood framing.
  - 2. Attach to concrete or masonry with stub nails, screws designed for masonry attachment, or powder-driven fasteners spaced 24 inches (610 mm) o.c.

### 3.5 INSTALLING SUSPENSION SYSTEMS

- A. Install suspension system components according to spacings indicated, but not greater than spacings required by referenced installation standards for assembly types.
  - 1. Hangers: 48 inches (1219 mm) o.c.
  - 2. Carrying Channels (Main Runners): 48 inches (1219 mm) o.c.

3. Furring Channels (Furring Members): 16 inches (406 mm) o.c.
- B. Isolate suspension systems from building structure where they abut or are penetrated by building structure to prevent transfer of loading imposed by structural movement.
- C. Suspend hangers from building structure as follows:
1. Install hangers plumb and free from contact with insulation or other objects within ceiling plenum that are not part of supporting structural or suspension system.
    - a. Splay hangers only where required to miss obstructions and offset resulting horizontal forces by bracing, countersplaying, or other equally effective means.
  2. Where width of ducts and other construction within ceiling plenum produces hanger spacings that interfere with locations of hangers required to support standard suspension system members, install supplemental suspension members and hangers in the form of unistrut or equivalent devices.
  3. Wire Hangers: Secure by looping and wire tying, either directly to structures or to inserts, eye screws, or other devices and fasteners that are secure and appropriate for substrate, and in a manner that will not cause hangers to deteriorate or otherwise fail.
  4. Flat Hangers: Secure to structure, including intermediate framing members, by attaching to inserts, eye screws, or other devices and fasteners that are secure and appropriate for structure and hanger, and in a manner that will not cause hangers to deteriorate or otherwise fail.
  5. Do not attach hangers to steel roof deck.
  6. Do not attach hangers to permanent metal forms. Furnish cast-in-place hanger inserts that extend through forms.
  7. Do not attach hangers to rolled-in hanger tabs of composite steel floor deck.
  8. Do not connect or suspend steel framing from ducts, pipes, or conduit.
- D. Fire-Resistance-Rated Assemblies: Wire tie furring channels to supports.
- E. Seismic Bracing: Sway-brace suspension systems with hangers used for support.
- F. Grid Suspension Systems: Attach perimeter wall track or angle where grid suspension systems meet vertical surfaces. Mechanically join main beam and cross-furring members to each other and butt-cut to fit into wall track.
- G. Installation Tolerances: Install suspension systems that are level to within 1/8 inch in 12 feet (3 mm in 3.6 m) measured lengthwise on each member that will receive finishes and transversely between parallel members that will receive finishes.

END OF SECTION



## Design No. U411 BXUV.U411 Fire Resistance Ratings - ANSI/UL 263

[Page Bottom](#)

### Design/System/Construction/Assembly Usage Disclaimer

- Authorities Having Jurisdiction should be consulted in all cases as to the particular requirements covering the installation and use of UL Certified products, equipment, system, devices, and materials.
- Authorities Having Jurisdiction should be consulted before construction.
- Fire resistance assemblies and products are developed by the design submitter and have been investigated by UL for compliance with applicable requirements. The published information cannot always address every construction nuance encountered in the field.
- When field issues arise, it is recommended the first contact for assistance be the technical service staff provided by the product manufacturer noted for the design. Users of fire resistance assemblies are advised to consult the general Guide Information for each product category and each group of assemblies. The Guide Information includes specifics concerning alternate materials and alternate methods of construction.
- Only products which bear UL's Mark are considered Certified.

### BXUV - Fire Resistance Ratings - ANSI/UL 263

### BXUV7 - Fire Resistance Ratings - CAN/ULC-S101 Certified for Canada

[See General Information for Fire-resistance Ratings - ANSI/UL 263](#)

[See General Information for Fire Resistance Ratings - CAN/ULC-S101 Certified for Canada](#)

## Design No. U411

February 25, 2015

**Nonbearing Wall Rating — 2 HR.**

**\* Indicates such products shall bear the UL or cUL Certification Mark for jurisdictions employing the UL or cUL Certification (such as Canada), respectively.**

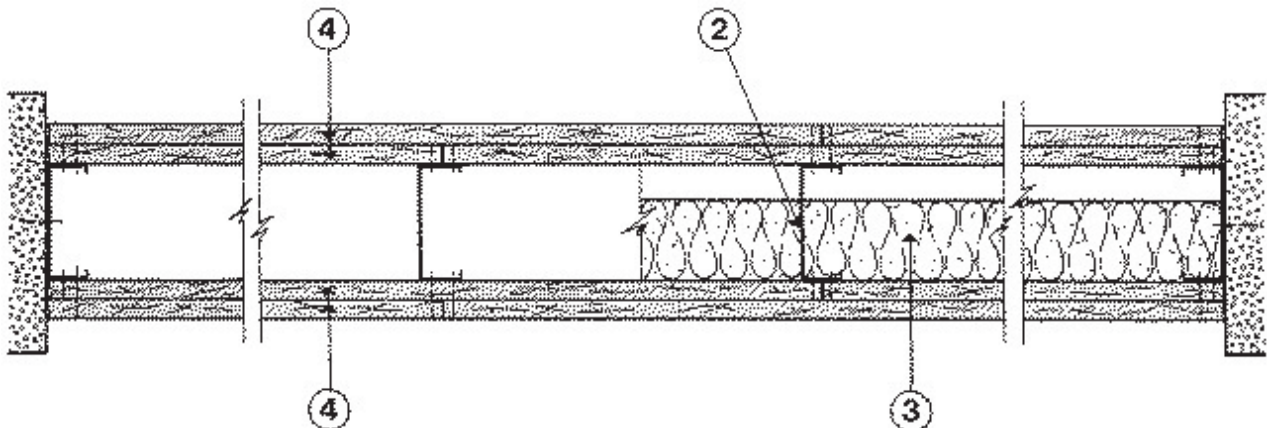

1. **Floor and Ceiling Runner** — (Not Shown) — Min. 25 MSG galv steel, 1 in. return legs, 2-1/2 in. deep (min), attached to floor and ceiling with fasteners 24 in. OC max.

1A. **Framing Members\*— Floor and Ceiling Runners** — (Not shown) — As an alternate to Item 1 - For use with Item 2A, channel shaped, min 2-1/2 in. deep, attached to floor and ceiling with fasteners 24 in. OC. max.

**ALLSTEEL & GYPSUM PRODUCTS INC** — Type SUPREME Framing System

**CALIFORNIA EXPANDED METAL PRODUCTS CO** — Viper20™ Track

**CONSOLIDATED FABRICATORS CORP, BUILDING PRODUCTS DIV** — Type SUPREME Framing System

**MARINO/WARE, DIV OF WARE INDUSTRIES INC** — Viper20™ Track

**PHILLIPS MFG CO L L C** — Viper20™ Track

**QUAIL RUN BUILDING MATERIALS INC** — Type SUPREME Framing System

**SCAFCO STEEL STUD MANUFACTURING CO** — Type SUPREME Framing System

**STEEL CONSTRUCTION SYSTEMS INC** — Type SUPREME Framing System

**UNITED METAL PRODUCTS INC** — Type SUPREME Framing System

1B. **Floor and Ceiling Runners** — (Not shown)—For use with Item 2B- Channel shaped, fabricated from min 20 MSG corrosion-protected or galv steel, min width to accommodate stud size, with min 1 in. long legs, attached to floor and ceiling with fasteners spaced max 24 in. OC.

1C. **Framing Members\*— Floor and Ceiling Runners** — (Not shown) — As an alternate to Item 1 - For use with Item 2C, channel shaped, min 2-1/2 in. wide fabricated from min 0.015 in. thick galv steel, attached to floor and ceiling with fasteners 24 in. OC. max.

**CLARKDIETRICH BUILDING SYSTEMS** — CD ProTRAK

**DMFCWBS L L C** — ProTRAK

**MBA METAL FRAMING** — ProTRAK

**RAM SALES L L C** — Ram ProTRAK

**STEEL STRUCTURAL SYSTEMS L L C** — Tri-S ProTRAK

1D. **Framing Members\*— Floor and Ceiling Runners** — (Not shown) — As an alternate to Item 1 - For use with Item 2D, channel shaped, min 2-1/2 in. wide fabricated from min 0.018 in. thick galv steel, attached to floor and ceiling with fasteners 24 in. OC. max.

**TELLING INDUSTRIES L L C** — TRUE-TRACK™

1E. **Framing Members\*— Floor and Ceiling Runners** — (Not shown) — As an alternate to Item 1 - For use with Item 2E, channel shaped, min 2-1/2 in. wide fabricated from min 25 MSG steel, attached to floor and ceiling with fasteners 24 in. OC. max.

**KIRII (HONG KONG) LTD** — Type KIRII

1F. **Floor and Ceiling Runners** — (Not shown) — Channel shaped, fabricated from min 0.02 in. galv steel, min width to accommodate stud size, with min 1 in. long legs, for use with studs specified below and fabricated from min 0.02 in. galv steel or thicker, attached to floor and ceiling with fasteners spaced max 24 in. OC.

**MARINO/WARE, DIV OF WARE INDUSTRIES INC** — Viper20™ Track VT100.

1G. **Framing Members\*— Floor and Ceiling Runners** — (Not shown) — As an alternate to Item 1 - For use with Item 2G, channel shaped, min 2-1/2 in. deep, attached to floor and ceiling with fasteners 24 in. OC. max.

**TELLING INDUSTRIES L L C** — Viper20™ Track

2. **Steel Studs** — Min 2-1/2 in. deep, formed of min 25 MSG galv steel max stud spacing 24 in. OC. Studs to be cut 3/4 in. less than assembly height.

2A. **Framing Members\*— Steel Studs** — As an alternate to Item 2 - For use with Item 1G, channel shaped studs, min 2-1/2 in. deep, spaced a max of 24 in. OC. Studs to be cut 3/4 in. less than assembly height.

**ALLSTEEL & GYPSUM PRODUCTS INC** — Type SUPREME Framing System

**CALIFORNIA EXPANDED METAL PRODUCTS CO** — Viper20™

**CONSOLIDATED FABRICATORS CORP, BUILDING PRODUCTS DIV** — Type SUPREME Framing System

**MARINO/WARE, DIV OF WARE INDUSTRIES INC** — Viper20™

**PHILLIPS MFG CO L L C** — Viper20™

**QUAIL RUN BUILDING MATERIALS INC** — Type SUPREME Framing System

**SCAFCO STEEL STUD MANUFACTURING CO** — Type SUPREME Framing System

**STEEL CONSTRUCTION SYSTEMS INC** — Type SUPREME Framing System

**UNITED METAL PRODUCTS INC** — Type SUPREME Framing System

2B. **Steel Studs** — (As an alternate to Item 2, For use with Item 4D) Channel shaped, fabricated from min 20 MSG corrosion-protected or galv steel, 3-1/2 in. min depth, spaced a max of 16 in. OC. Studs friction-fit into floor and ceiling runners. Studs to be cut 5/8 to 3/4 in. less than assembly height.

2C. **Framing Members\*— Steel Studs** — As an alternate to Item 2 - For use with Item 1C, channel shaped studs, min 2-1/2 in. wide fabricated from min 0.015 in. thick galv steel, spaced a max of 24 in. OC. Studs to be cut 3/4 in. less than assembly height.

**CLARKDIETRICH BUILDING SYSTEMS** — CD ProSTUD

**DMFCWBS L L C** — ProSTUD

**MBA METAL FRAMING** — ProSTUD

**RAM SALES L L C** — Ram ProSTUD

**STEEL STRUCTURAL SYSTEMS L L C** — Tri-S ProSTUD

2D. **Framing Members\*— Steel Studs** — As an alternate to Item 2 - For use with Item 1D, channel shaped studs, min 2-1/2 in. wide fabricated from min 0.018 in. thick galv steel, spaced a max of 24 in. OC. Studs to be cut 3/4 in. less than assembly height.

**TELLING INDUSTRIES L L C** — TRUE-STUD™

2E. **Framing Members\*— Steel Studs** — As an alternate to Item 2 - For use with Item 1E, channel shaped studs, min 2-1/2 in. wide fabricated from min 25 MSG steel, spaced a max of 24 in. OC. Studs to be cut 3/4 in. less than assembly height.

**KIRII (HONG KONG) LTD** — Type KIRII

2F. **Framing Members\*— Steel Studs** — As an alternate to Item 2 - For use with Item 1G, channel shaped studs, min 2-1/2 in. deep, spaced a max of 24 in. OC. Studs to be cut 3/4 in. less than assembly height.

**TELLING INDUSTRIES L L C** — Viper20™

2G. **Framing Members\*— Steel Studs** — As an alternate to Item 2 - For use with Item 1, channel shaped studs, Min 2-1/2 in. deep, formed of min 25 MSG galv steel max stud spacing 24 in. OC. Studs to be cut 3/4 in. less than assembly height.

**EB MÉTAL INC** — EB Stud

2H. **Framing Members\*— Steel Studs** — As an alternate to Item 2 - For use with Item 1, channel shaped studs, Min 2-1/2 in. deep, formed of min 25 MSG galv steel max stud spacing 24 in. OC. Studs to be cut 3/4 in. less than assembly height.

**OLMAR SUPPLY INC** — PRIMESTUD

3. **Batts and Blankets\*** — (Optional) — Mineral wool or glass fiber batts partially or completely filling stud cavity.

See **Batts and Blankets** (BZJZ) category for names of manufacturers.

3A. **Fiber, Sprayed\*** — As an alternate to Batts and Blankets (Item 3) — (100% Borate Formulation) — Spray applied cellulose material. The fiber is applied with water to completely fill the enclosed cavity in accordance with the application instructions supplied with the product with a nominal dry density of 2.7 lb/ft<sup>3</sup>. Alternate Application Method: The fiber is applied without water or adhesive at a nominal dry density of 3.5 lb/ft<sup>3</sup>, in accordance with the application instructions supplied with the product.

**U S GREENFIBER L L C** — INS735 & INS745 for use with wet or dry application. INS765LD and INS770LD are to be used for dry application only.

3B. **Fiber, Sprayed\*** — As an alternate to Batts and Blankets (Item 3) and Item 3A - Spray applied cellulose insulation material. The fiber is applied with water to interior surfaces in accordance with the application instructions supplied with the product. Applied to completely fill the enclosed cavity. Minimum dry density of 4.3 pounds per cubic ft.

**NU-WOOL CO INC** — Cellulose Insulation

3C. **Fiber, Sprayed\*** — As an alternate to Batts and Blankets (Item 3) - Spray applied cellulose fiber. The fiber is applied with water to completely fill the enclosed cavity in accordance with the application instructions supplied with the product. The minimum dry density shall be 4.30 lbs/ft<sup>3</sup>.

**INTERNATIONAL CELLULOSE CORP** — Celbar-RL

4. **Gypsum Board\*** — 5/8 in. thick, outer layer paper, glass mat or vinyl surfaced. (Laminated System) Gypsum board applied vertically in two layers. Inner layer attached to studs with 1 in. long Type S steel screws spaced 8 in. OC along vertical edges, and 12 in. OC in the field and outer layer laminated to inner layer with joint compound, applied with a notched spreader producing continuous beads of compound about 3/8 in. in diameter, spaced not greater than 2 in. OC. Joints of laminated outer layer offset 12 in. from inner layer joints Outer layer gypsum board attached to floor and ceiling runner track with 1-5/8 in. long Type S steel screws spaced 12 in. OC.

Optional, (Direct Attached System), Inner layer attached to studs with 1 in. long Type S steel screws spaced 16 in. OC in the field and along the vertical edges. Outer layer attached to the studs over the inner layer with 1-5/8 in. long Type S steel screws spaced 16 in. OC in the field and along the vertical edges and 12 in. OC to the floor and ceiling runners. Joints of screw-attached outer layer offset from inner layer joints. Joints of outer layer may be taped or untaped.

Nom 3/32 in. thick gypsum veneer plaster may be applied to the entire surface of Classified veneer baseboard. Joints reinforced.

**ACADIA DRYWALL SUPPLIES LTD** — Type X, 5/8 Type X, Type Blueglass Exterior Sheathing

**AMERICAN GYPSUM CO** — Types AG-C, AGX-1, M-Glass, AGX-11.

**BEIJING NEW BUILDING MATERIALS PUBLIC LTD CO** — Type DBX-1.

**CERTAINTED GYPSUM INC** — Types 1, FRPC, EGRG, GlasRoc, Type X or Type C, 5/8" Easi-Lite Type X.

**CGC INC** — Type AR, C, IP-AR, IP-X1, IP-X2, IPC-AR, SCX, SHX, WRC or WRX.

**CONTINENTAL BUILDING PRODUCTS OPERATING CO, L L C** — Types LGFC2A, LGFC6A, LGFC-C/A, LGFC-WD, LGLLX.



**GEORGIA-PACIFIC GYPSUM L L C** — Types 5, 6, 9, C, DAP, DD, DA, DAPC, DGG, DS, GPFS6, LS, TG-C, Type X, Veneer Plaster Base-Type X, Water Rated-Type X, Sheathing Type-X, Soffit-Type X, GreenGlass Type X, Type X ComfortGuard Sound Deadening Gypsum Board, Type LWX, Veneer Plaster Base-Type LWX, Water Rated-Type LWX, Sheathing Type-LWX, Soffit-Type LWX, Type DGLW, Water Rated-Type DGLW, Sheathing Type- DGLW, Soffit-Type DGLW, Type LW2X, Veneer Plaster Base - Type LW2X, Water Rated - Type LW2X, Sheathing - Type LW2X, Soffit - Type LW2X, Type DGL2W, Water Rated - Type DGL2W, Sheathing - Type DGL2W.

**NATIONAL GYPSUM CO** — Types eXP-C, FSK, FSK-C, FSW, FSW-3, FSW-5, FSW-6, FSW-8, FSW-C, FSW-G, FSMR-C, FSL, SoundBreak XP Type X Gypsum Board.

**PABCO BUILDING PRODUCTS L L C, DBA PABCO GYPSUM** — Type C, PG-3, PG-5, PG-9, PG-11, PG-C, PGS-WRS.

**PANEL REY S A** — Types GREX, PRX, RHX, MDX, ETX or PRC.

**SIAM GYPSUM INDUSTRY (SARABURI) CO LTD** — Type EX-1

**THAI GYPSUM PRODUCTS PCL** — Type C or Type X

**UNITED STATES GYPSUM CO** — Type AR, C, FRX-G, IP-AR, IP-X1, IP-X2, IPC-AR, SCX, SGX, SHX, WRC, WRX, USGX.

**USG MEXICO S A DE C V** — Type AR, C, IP-AR, IP-X1, IP-X2, IPC-AR, SCX, SHX, WRC or WRX.

4A. **Gypsum Board\*** — (As an alternate to Item 4) — Nom 3/4 in. thick, installed as described in Item 4 with 1-1/4 in. long Type S screws for inner layer and 2-1/4 in. long Type S screws for outer layer.

**CGC INC** — Types AR, IP-AR.

**UNITED STATES GYPSUM CO** — Types AR, IP-AR.

**USG MEXICO S A DE C V** — Types AR, IP-AR.

4B. **Gypsum Board\*** — (As an alternate to Item 4 and 4A) — 5/8 in. thick, 24 to 54 in. wide, applied horizontally as the outer layer to one side of the assembly. Horizontal joints need not be backed by steel framing. Secured as described in Item 4 for the direct attached system. When used in widths other than 48 in., gypsum panels to be installed horizontally.

**CERTAINEED GYPSUM INC** — Type X, Type C.

**CGC INC** — Type SHX.

**THAI GYPSUM PRODUCTS PCL** — Type X, Type C.

**UNITED STATES GYPSUM CO** — Type SHX, FRX-G.

**USG MEXICO S A DE C V** — Type SHX.

4C. **Gypsum Board\*** — (As an alternate to Items 4, 4A and 4B) — Two layers of 5/8 in. thick gypsum board applied horizontally or vertically. Inner layer attached to studs with No. 6 by 1 in. long Type S bugle head screws spaced 24 in. OC along the top and bottom tracks starting 2 in. and then 12 in. from the vertical edge. Inner layer screws spaced 24 in. OC along the studs, starting 2 in. and then 12 in. from the top and bottom of the studs and starting 1-1/4 in. from the horizontal joints when installed horizontally. Outer layer attached to studs with 1-5/8 in. long Type S bugle head screws spaced 16 in. OC along the top and bottom tracks starting 1-3/4 in. from the vertical edge. Outer layer screws spaced 16 in. OC along the studs, starting 1-3/4 in. and then 8 in. from the top and bottom of the studs and starting 1-

1/4 in. and then 8 in. from the horizontal joints when installed horizontally. Vertical joints centered over studs and staggered one stud cavity on opposite sides of studs. Vertical joints in adjacent layers staggered one stud cavity. Horizontal joints need not be backed by steel framing. Horizontal edge joints and horizontal butt joints on opposite sides of studs need not be staggered. Horizontal edge joints and horizontal butt joints in adjacent layers staggered a min of 12 in. When outer layers are installed horizontally, vinyl or casein, dry or premixed joint compound shall be applied in two coats to joints and screw heads of outer layer. Paper tape, nom 2 in. wide, embedded in first layer of compound over all joints of outer layer panels. Nom 3/32 in. thick gypsum veneer plaster may be applied to the entire surface of Classified veneer baseboard. Joints reinforced.

**GEORGIA-PACIFIC GYPSUM L L C** — Types 5, 6, 9, C, DAP, DD, DA, DAPC, DGG, DS, GPFS6, LS, TG-C, Type X, Veneer Plaster Base-Type X, Water Rated-Type X, Sheathing Type-X, Soffit-Type X, GreenGlass Type X, Type X ComfortGuard Sound Deadening Gypsum Board, Type LWX, Veneer Plaster Base-Type LWX, Water Rated-Type LWX, Sheathing Type-LWX, Soffit-Type LWX, Type DGLW, Water Rated-Type DGLW, Sheathing Type- DGLW, Soffit-Type DGLW, Type LW2X, Veneer Plaster Base - Type LW2X, Water Rated - Type LW2X, Sheathing - Type LW2X, Soffit - Type LW2X, Type DGL2W, Water Rated - Type DGL2W, Sheathing - Type DGL2W.

4D. **Gypsum Board\*** — (Not Shown) - (As an alternate to Item 4 when used as the base layer on one or both sides of wall. For direct attachment only to steel studs Item 2B) - Nom 5/8 in. thick lead backed gypsum panels with beveled, square or tapered edges, applied vertically. Vertical joints centered over studs and staggered min 1 stud cavity on opposite sides of studs. Gypsum board secured to studs with 1-1/4 in. long Type S-12 steel screws spaced 8 in. OC at perimeter and 12 in. OC in the field.

**RAY-BAR ENGINEERING CORP** — Type RB-LBG

4E. **Gypsum Board\*** — (As an alternate to Items 4 through 4D) — Nominal 5/8 in. thick, 4 ft wide panels, applied vertically and secured as described in Item 4.

**PABCO BUILDING PRODUCTS L L C, DBA PABCO GYPSUM** — Types QuietRock ES.

4F. **Gypsum Board\*** — (As an alternate to Items 4 through 4E) - 5/8 in. thick, 4 ft. wide, paper surfaced, applied vertically and secured as described in Item 4.

**CERTAINTED GYPSUM INC** — Type SilentFX

4G. **Gypsum Board\*** — As an alternate to Item 4- Nom. 5/8 in. thick, inner layer attached vertically to studs with 1 in. long Type S steel screws spaced 16 in. OC in the field and along the vertical edges. Outer layer attached to the studs horizontally over the inner layer with 1-5/8 in. long Type S steel screws spaced 16 in. OC in the field and along the vertical edges and 12 in. OC to the floor and ceiling runners. Joints of outer layer must be taped. Nom 3/32 in. thick gypsum veneer plaster may be applied to the entire surface of Classified veneer baseboard.

**ACADIA DRYWALL SUPPLIES LTD** — Type Blueglass Exterior Sheathing

**PABCO BUILDING PRODUCTS L L C, DBA PABCO GYPSUM** — Types C, PG-11, PGS-WRS.

4H. **Gypsum Board\*** — (Not Shown) - (As an alternate to Items 4) For Direct Application to Studs Only- For use as the base layer on one or both sides of the wall. Nom 5/8 in. thick lead backed gypsum panels with beveled, square or tapered edges, applied vertically. Vertical joints centered over studs and staggered min 1 stud cavity on opposite sides of studs. Wallboard secured to studs with 1-5/8 in. long Type S 12 steel screws spaced 8 in. OC at perimeter and 12 in OC in the field. Lead batten strips required behind vertical joints of lead backed gypsum wallboard and optional at remaining stud locations. Fasteners for face layer gypsum panels when installed over lead backed board to be min 2-1/2 in. Type S-12 bugle head steel screws spaced as described in Item 4. To be used with Lead Batten Strips (see Item 5A) or Lead Discs (see Item 6A).

**MAYCO INDUSTRIES INC** — Type X-Ray Shielded Gypsum

4I. **Gypsum Board\*** — (As an alternate to Item 4, not for use with Items 1C and 2C) - Nom. 5/8 in. thick gypsum panels with beveled, square or tapered edges installed as described in Item 4.

**CGC INC** — Type ULX

**UNITED STATES GYPSUM CO** — Type ULX.

**USG MEXICO S A DE C V** — Type ULX

4J. **Gypsum Board\*** — (As an alternate to Item 4 when used as the base layer on one or both sides of wall. For direct attachment only to steel studs Item 2B). Nom 5/8 in. thick lead backed gypsum panels with beveled, square or tapered edges, applied vertically. Vertical joints centered over studs and staggered min 1 stud cavity on opposite sides of studs.

Wallboard secured to studs with 1-1/4 in. long Type S-12 steel screws gypsum panel steel screws spaced 8 in. OC at perimeter and 12 in. OC in the field. Lead batten strips required behind vertical joints of lead backed gypsum wallboard and optional at remaining stud locations. Lead batten strips, min 2 in. wide, max 8 ft long with a max thickness of 0.14 in. placed on the face of studs and attached to the stud with construction adhesive and two 1 in. long Type S-12 pan head steel screws, one at the top of the strip and one at the bottom of the strip. Lead discs, nominal 3/8 in. diam by max 0.085 in. thick. Compression fitted or adhered over the screw heads. Lead batten strips and discs to have a purity of 99.9% meeting the Federal specification QQ-L-201f, Grade "C".

**RADIATION PROTECTION PRODUCTS INC** — Type RPP - Lead Lined Drywall

4K. **Gypsum Board** — (As an alternate to Items 4 through 4J, not for use with Items 1C and 2C). Two layers of nominal 15 mm thick gypsum board applied vertically. Inner layer attached to studs with No. 3.5 x 1-3/8 in. long bugle head, self-drilling screws spaced 23-5/8 in. OC in the field and 15-3/4 in. OC in the perimeter, with the first screw 2 in. from the edge. Outer layer attached to the studs over the inner layer with No. 3.5 x 1-3/4 in. long bugle head, self-drilling screws spaced 11-13/16 in. OC in the field and 7-7/8 in. OC in the perimeter, with the first screw 3/4 in. from the edge. Outer layer screws staggered from inner layer screws. Vertical joints centered over studs and staggered one stud cavity on opposite sides of studs. Vertical joints in adjacent layer staggered one stud cavity. Self-adhesive fiberglass mesh (9x9 mesh) tape, nom 2 in. wide, applied over all joints of outer layer panels. Dry or premixed joint compound applied in two coats to joints over the mesh tape and screw heads of outer layer.

**GYPSEMNA CO LLC** — Types MRFW, FW, TF.

4L. **Gypsum Board\*** — (As an alternate to Items 4 through 4K) - Two layers of 5/8 in. thick gypsum board applied vertically or horizontally. Inner layer attached to studs with #6 x 1 in. long bugle head screws spaced 12 in. OC along the top and bottom tracks and 16 in. OC in the field and along the vertical edges. Outer layer attached to studs with #6 x 1-5/8 in. long bugle head screws spaced 12 in. OC along the top and bottom tracks and 16 in. OC in the field and along the vertical edges. Vertical joints are centered over studs and staggered between layers and on opposite sides of the wall. Horizontal joints on the face layer are staggered 12 in. from the base layer. Horizontal joints need not to be backed by steel framing.

**CONTINENTAL BUILDING PRODUCTS OPERATING CO, L L C** — Type LGFC6A, LGFC-C/A.

4M. **Wall and Partition Facings and Accessories\*** — (As an alternate to Items 4 through 4L) — Nominal 5/8 in. thick, 4 ft wide panels, applied vertically and secured as described in Item 4.

**PABCO BUILDING PRODUCTS L L C, DBA PABCO GYPSUM** — Type QuietRock 527.

4N. **Gypsum Board\*** — (As an alternate to Item 4 through 4M) - For direct application to studs only - Four layers nom. 5/16 in. thick gypsum panels applied vertically or horizontally. When applied horizontally, base layer secured to studs with 1 in. Type S screws spaced 24 in. OC. Second layer installed with joints offset 12 in. from base layer and secured with 1 in. Type S screws spaced 24 in. OC. Third layer installed with joints in line with base layer and secured with 1-1/2 in. Type S screws spaced 16 in. OC. Fourth layer installed with joints in line with second layer and secured with 1-5/8 in. Type S screws spaced 12 in. OC. For all layers, screws offset 4 in. from previous layer. When applied vertically, base layer secured with 1 in. Type S screws spaced 24 in. OC. Second layer secured with joints offset one stud cavity and secured with 1 in. Type S screws spaced 24 in. OC. Third layer installed with joints in line with base layer and secured with 1-1/2 in. Type S screws spaced 12 in. OC. Fourth layer secured with joints in line with second layer and secured with 1-5/8 in. Type S screws spaced 8 in. OC along vertical edges and 12 in. OC in the field. For all layers, screws offset 4 in. from previous layer.

**NATIONAL GYPSUM CO** — Type FSW

5. **Lead Batten Strips** — (Not Shown, For Use With Item 4D) - Lead batten strips, min 1-1/2 in. wide, max 10 ft long with a max thickness of 0.125 in. Strips placed on the interior face of studs and attached from the exterior face of the stud with two 1 in. long Type S-12 pan head steel screws, one at the top of the strip and one at the bottom of the strip. Lead batten strips to have a purity of 99.9% meeting the Federal specification QQ-L-201f, Grade "C". Lead batten strips required behind vertical joints of lead backed gypsum board (Item 4D) and optional at remaining stud locations. Required behind vertical joints.

5A. **Lead Batten Strips** — (Not Shown, for use with Item 4H) Lead batten strips, 2 in. wide, max 10 ft long with a max thickness of 0.140 in. Strips placed on the face of studs and attached to the stud with two min. 1 in. long min. Type S-8 pan head steel screws, one at the top of the strip and one at the bottom of the strip or with one min. 1 in. long min. Type S-8 pan head steel screw at the top of the strip. Lead batten strips to have a purity of 99.5% meeting the Federal specification QQ-L-201f, Grades "B, C or D". Lead batten strips required behind vertical joints of lead backed gypsum wallboard (Item 6) and optional at remaining stud locations.

6. **Lead Discs or Tabs** — (Not Shown, For Use With Item 4D) - Used in lieu of or in addition to the lead batten strips (Item 5) or optional at other locations - Max 3/4 in. diam by max 0.125 in. thick lead discs compression fitted or adhered over steel screw heads or max 1/2 in. by 1-1/4 in. thick lead tabs placed on gypsum boards (Item 4D) underneath screw locations prior to the installation of the screws. Lead discs or tabs to have a purity of 99.9% meeting the Federal specification QQ-L-201f, Grade "C".

6A. **Lead Discs** — (Not Shown, for use with Item 4H) Max 5/16 in. diam by max 0.140 in. thick lead discs compression fitted or adhered over steel screw heads. Lead discs to have a purity of 99.5% meeting the Federal Specification QQ-L-201f, Grades "B, C or D".

**7. Mineral and Fiber Board\*** — (Optional, Not shown) — For optional use as an additional layer on one side of wall. Nom 1/2 in. thick, 4 ft wide with long dimension parallel and centered over studs. Attached to studs and floor and ceiling runners with 1-5/8 in. long Type S steel screws, spaced 12 in. OC. The required UL Classified gypsum board layer(s) is/are to be installed as indicated as to fastener type and spacing, except that the required fastener length shall be increased by a minimum of 1/2 in. Not evaluated or intended as a substitute for the required layer(s) of UL Classified Gypsum Board.

**HOMASOTE CO** — Homasote Type 440-32

**\* Indicates such products shall bear the UL or cUL Certification Mark for jurisdictions employing the UL or cUL Certification (such as Canada), respectively.**

Last Updated on 2015-02-25

---

[Questions?](#)

[Print this page](#)

[Terms of Use](#)

[Page Top](#)

© 2015 UL LLC

When the UL Leaf Mark is on the product, or when the word "Environment" is included in the UL Mark, please search the [UL Environment database](#) for additional information regarding this product's certification.

The appearance of a company's name or product in this database does not in itself assure that products so identified have been manufactured under UL's Follow-Up Service. Only those products bearing the UL Mark should be considered to be Certified and covered under UL's Follow-Up Service. Always look for the Mark on the product.

UL permits the reproduction of the material contained in the Online Certification Directory subject to the following conditions: 1. The Guide Information, Assemblies, Constructions, Designs, Systems, and/or Certifications (files) must be presented in their entirety and in a non-misleading manner, without any manipulation of the data (or drawings). 2. The statement "Reprinted from the Online Certifications Directory with permission from UL" must appear adjacent to the extracted material. In addition, the reprinted material must include a copyright notice in the following format: "© 2015 UL LLC".



## Design No. U415 BXUV.U415 Fire Resistance Ratings - ANSI/UL 263

[Page Bottom](#)

### Design/System/Construction/Assembly Usage Disclaimer

- Authorities Having Jurisdiction should be consulted in all cases as to the particular requirements covering the installation and use of UL Certified products, equipment, system, devices, and materials.
- Authorities Having Jurisdiction should be consulted before construction.
- Fire resistance assemblies and products are developed by the design submitter and have been investigated by UL for compliance with applicable requirements. The published information cannot always address every construction nuance encountered in the field.
- When field issues arise, it is recommended the first contact for assistance be the technical service staff provided by the product manufacturer noted for the design. Users of fire resistance assemblies are advised to consult the general Guide Information for each product category and each group of assemblies. The Guide Information includes specifics concerning alternate materials and alternate methods of construction.
- Only products which bear UL's Mark are considered Certified.

### BXUV - Fire Resistance Ratings - ANSI/UL 263

### BXUV7 - Fire Resistance Ratings - CAN/ULC-S101 Certified for Canada

[See General Information for Fire-resistance Ratings - ANSI/UL 263](#)

[See General Information for Fire Resistance Ratings - CAN/ULC-S101 Certified for Canada](#)

## Design No. U415

March 16, 2015

Nonbearing Wall Ratings – 1, 2, 3 or 4 Hr

\* Indicates such products shall bear the UL or cUL Certification Mark for jurisdictions employing the UL or cUL Certification (such as Canada), respectively.

System A – 1 Hr.

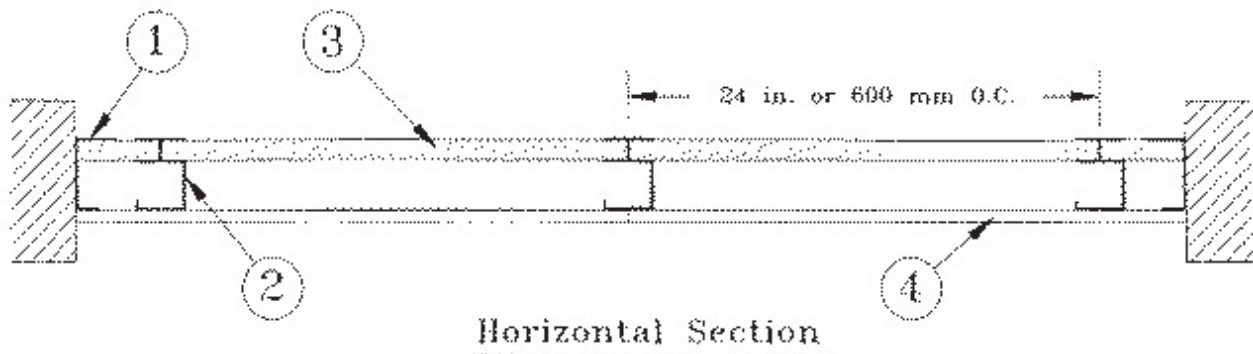

### System B - 2 Hr.

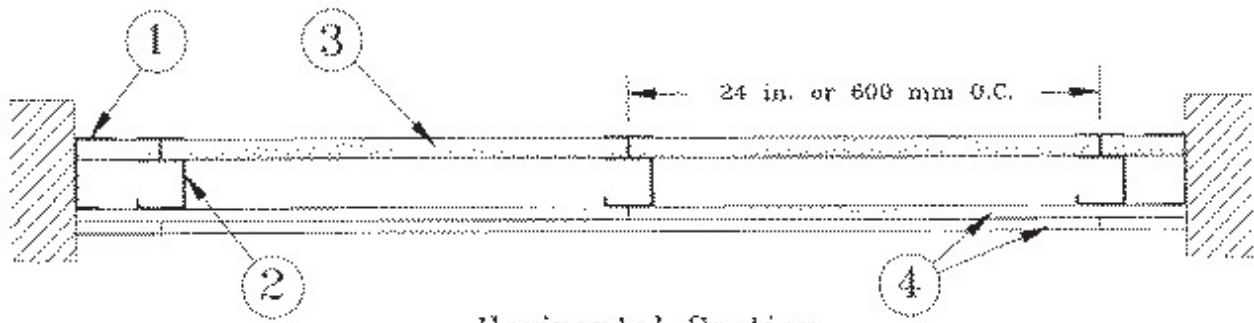

Horizontal Section  
System C - 2 Hr.

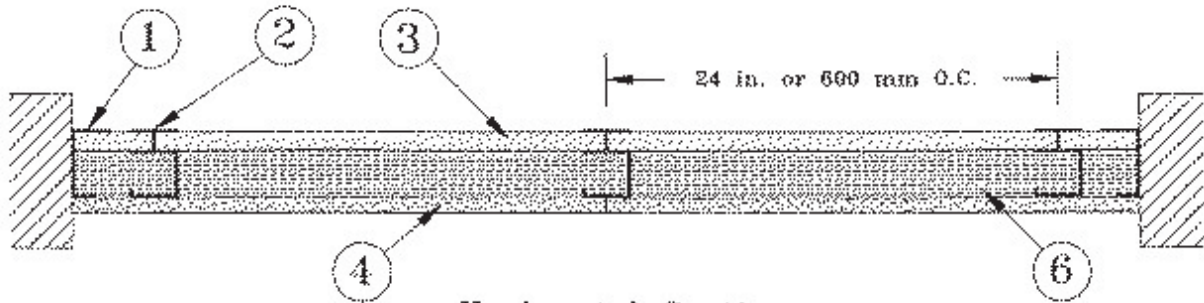

Horizontal Section  
System D - 2 Hr.

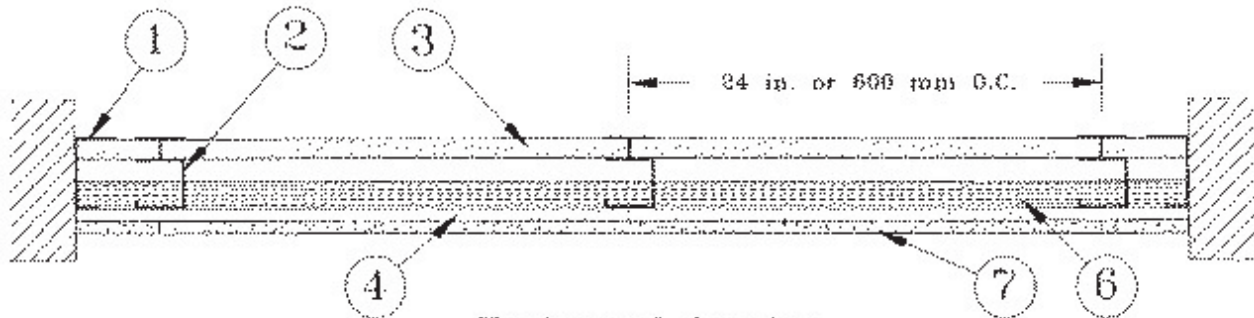

Horizontal Section  
System E - 2 Hr.

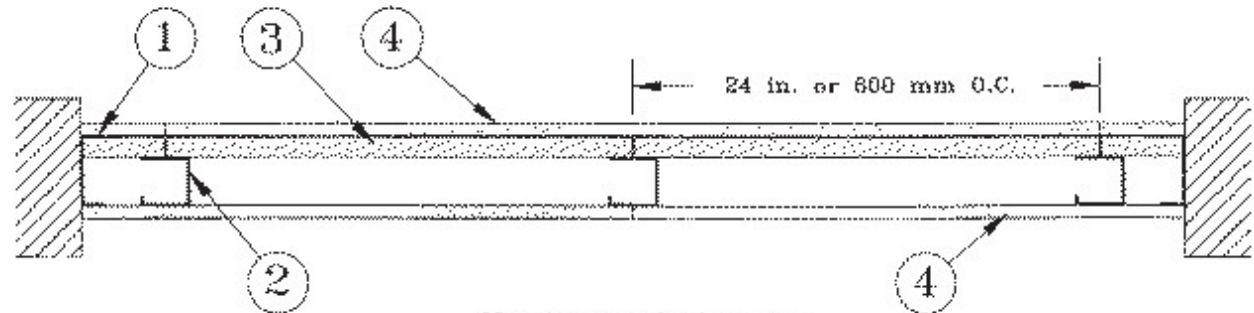

Horizontal Section

### System F - 2 Hr.

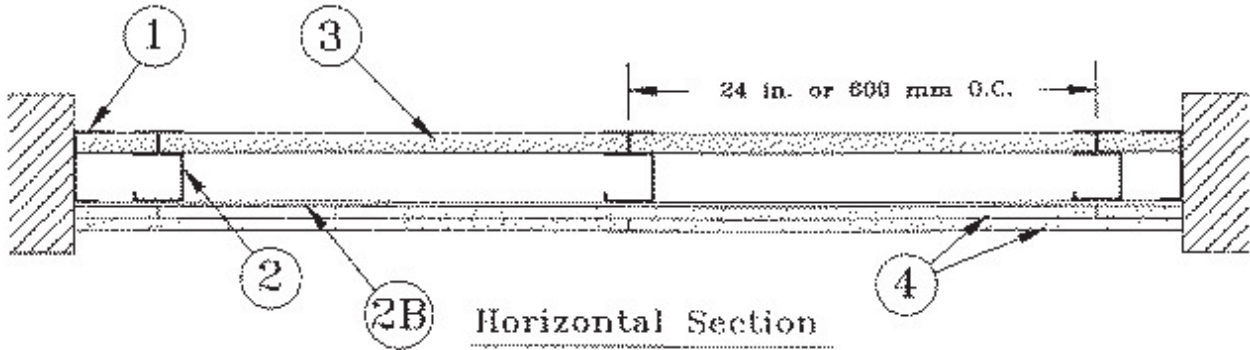

### System G - 3 Hr.

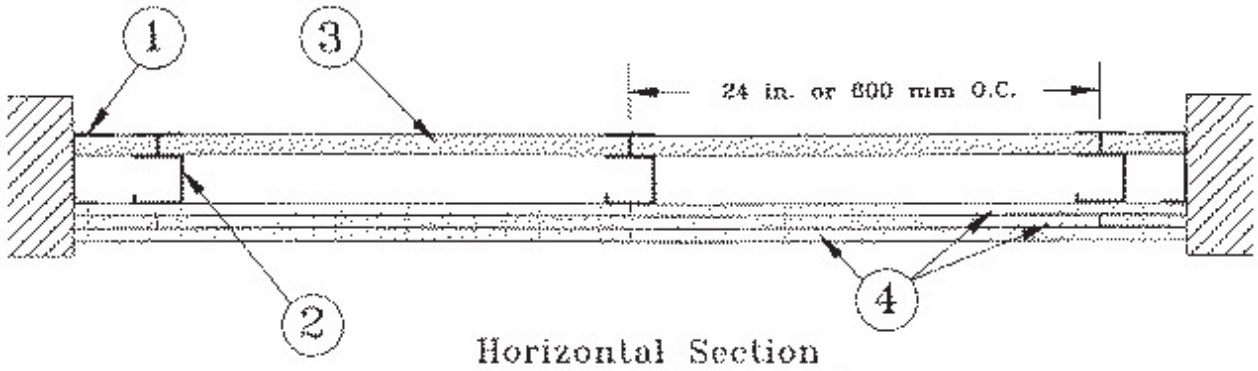

### System H - 3 Hr.

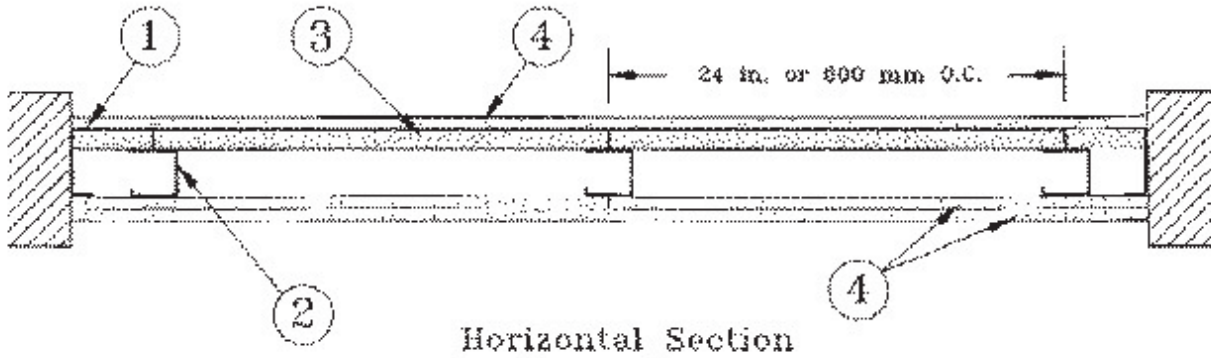

### System I - 4 Hr.

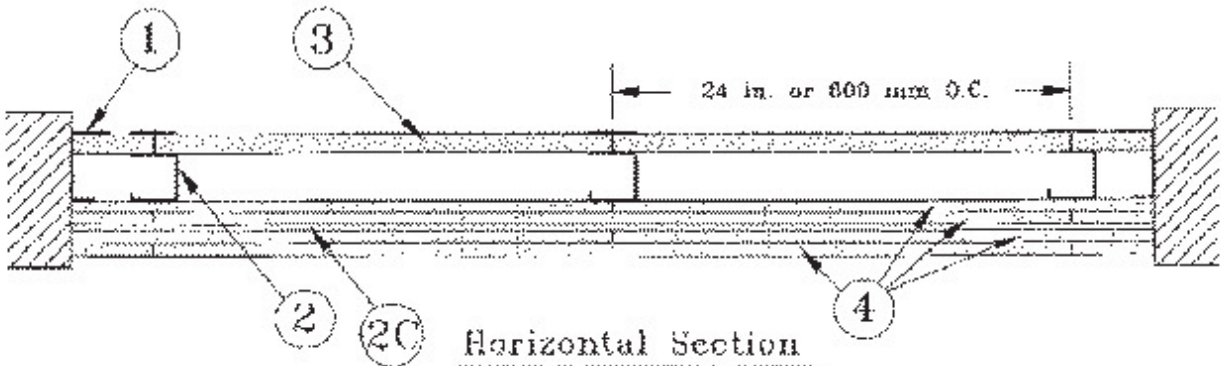

1. **Floor, Side and Ceiling Runners** - "J" - shaped runner, min 2-1/2 in. deep (min 4 in. deep when System C is used), with unequal legs of 1 in. and 2 in., fabricated from min 24 MSG (min 20 MSG when Item 4A, 4B or 7 are used) galv steel. Runners positioned with short leg toward finished side of wall. Runners attached to structural supports with

steel fasteners located not greater than 2 in. from ends and not greater than 24 in. OC. "E" - shaped studs (Item 2A) may be used as side runners in place of "J" - shaped runners.

2. **Steel Studs** — "C-H" - shaped studs, min 2-1/2 in. deep (min 4 in. deep when System C is used), fabricated from min 25 MSG (min 20 MSG when Items 2D, 4A, 4B or 7 is used) galv steel. Cut to lengths 3/8 to 1/2 in. less than floor-to-ceiling height and spaced 24 in. or 600 mm OC.

2A. **Steel Studs** — (Not Shown) — "E" - shaped studs installed back to back in place of "C-H" - shaped studs (Item 2) "E" - shaped studs secured together with steel screws spaced a maximum 12 in. OC. Fabricated from min 25 MSG (min 20 MSG when Item 2D, 4A, 4B or 7 is used) galv steel, min 2-1/2 in. deep (min 4 in. deep when System C is used), with one leg 1 in. long and two legs 3/4 in. long. Shorter legs 1 in. apart to engage gypsum liner panels. Cut to lengths 3/8 to 1/2 in. less than floor to ceiling heights.

2B. **Furring Channels** — (Optional, not shown) — For use with single or double layer systems. Resilient furring channels fabricated from min 25MSG corrosion protected steel, installed horizontally, and spaced vertically a max 24 in. OC. Flange portion of channel attached to each intersecting "C-H" or "E" stud on side of stud opposite the 1 in. liner panels with 1/2 in. long Type S or S-12 pan-head steel screws. When furring channels are used, wallboard to be installed vertically only. Not to be used with Type FRX-G gypsum wallboard, Type RB-LBG (Item 4A), Type Nelco (Item 4B) or cementitious backer units (Item 7).

2C. **Furring Channels** — For use with System I - "Hat" - shaped, 25 MSG galv steel furring channels attached directly over the inner layers of wallboard to each stud with 2 in. long Type S pan head steel screws. Screws alternate from top flange to bottom flange at each stud intersection. Furring channels spaced vertically max 24 in. OC.

2D. **Steel Framing Members\*** — (Optional, not shown) — For use with single or double layer systems. Furring channels and Steel Framing Members as described below. Not to be used with Type FRX-G gypsum wallboard, Type RB-LBG (Item 4A), Type Nelco (Item 4B) or cementitious backer units (Item 7):

a. **Furring Channels** — Formed of No. 25 MSG galv steel. 2-9/16 in. or 2-23/32 in. wide by 7/8 in. deep, spaced max. 24 in. OC perpendicular to studs. Channels secured to studs as described in Item b. Gypsum board installed vertically only and attached to furring channels as described in Item 3.

b. **Steel Framing Members\*** — Used to attach furring channels (Item 2Da) to studs (Item 2 or 2A). Clips spaced max. 24 in. OC., and secured to studs with No. 8 x 1-1/2 in. minimum self-drilling, S-12 steel screw through the center grommet. Furring channels are friction fitted into clips. RSIC-1 clip for use with 2-9/16 in. wide furring channels. RSIC-1 (2.75) clip for use with 2-23/32 in. wide furring channels.

**PAC INTERNATIONAL INC** — Types RSIC-1, RSIC-1 (2.75)

2E. **Steel Framing Members** — (Optional, Not Shown)\* - Furring channels and resilient sound isolation clip as described below:

a. **Furring Channels** — Formed of No. 25 MSG galv steel. Spaced 24 in. OC perpendicular to studs. Channels secured to studs as described in Item b. Ends of adjoining channels overlapped 6 in. and secured together with four self-tapping No. 8x1/2 Self Drilling screws (2 per side 1 in. and 4 in. from overlap edge). Gypsum board attached to furring channels as described in Item 3. Side joint furring channels shall be attached to studs with RESILMOUNT Sound Isolation Clips - Type A237R located approximately 2 in. from each end of length of channel. Both Gypsum Boards at side joints fastened into channel with screws spaced 8 in. OC, approximately 1/2 in. from joint edge.

b. **Steel Framing Members\*** — Resilient sound isolation clip used to attach furring channels (Item 2Ea) to studs. Clips spaced 24 in. OC., and secured to studs with No. 10 x 2-1/2 in. coarse drywall screw through the center hole. Furring channels are friction fitted into clips.

**STUDCO BUILDING SYSTEMS** — RESILMOUNT Sound Isolation Clips - Type A237R

2F. **Steel Framing Members\*** — (Optional, not shown) — For use with single or double layer systems. Furring channels and Steel Framing Members as described below. Not to be used with Type FRX-G gypsum wallboard, Type RB-LBG (Item 4A), Type Nelco (Item 4B) or cementitious backer units (Item 7):

a. **Furring Channels** — Formed of No. 25 MSG galv steel. 2-3/8 in. wide by 7/8 in. deep, spaced max. 24 in. OC perpendicular to studs. Channels secured to studs as described in Item b. Gypsum board installed vertically only and attached to furring channels as described in Item 3.

b. **Steel Framing Members\*** — Used to attach furring channels (Item 2Da) to studs (Item 2 or 2A ). Clips spaced max. 24 in. OC. GENIECLIPS secured to studs with No. 8 x 1-1/2 in. minimum self-drilling, S-12 steel screw through the center grommet. Furring channels are friction fitted into clips.

**PLITEQ INC** — Type GENIECLIP

3. **Gypsum Board\*** — Gypsum liner panels, nom 1 in. thick, 24 in. or 600 mm (for metric spacing) wide. Panels cut 1 in. less in length than floor to ceiling height. Vertical edges inserted in "H" portion of "C-H" studs or the gap between the two 3/4 in. legs of the "E" studs. Free edge of end panels attached to long leg of vertical "J" - runners with 1-5/8 in. long Type S steel screws spaced not greater than 12 in. OC. When wall height exceeds liner panel length, liner panel may be butted to extend to the full height of the wall. Horizontal joints need not be backed by steel framing. In



System I, butt joints in liner panels are staggered min 36 in. Butt joints backed with 6 in. by 22 in. strips of 3/4 in. thick gypsum wallboard (Item 4). Wallboard strips centered over butt joints and secured to liner panels with six 1-1/2 in. long Type G steel screws, three screws along the 22 in. dimension at the top and bottom of the strips.

**CGC INC** — Type SLX

**UNITED STATES GYPSUM CO** — Type SLX

**USG MEXICO S A DE C V** — Type SLX

#### 4. Gypsum Board\* —

##### System A — 1 Hr

Gypsum panels, with beveled, square or tapered edges, nom 5/8 in. thick, 48 in. or 1200 mm wide, applied vertically or horizontally, attached to studs with 1 in. long Type S steel screws spaced 12 in. when installed vertically or 8 in OC when installed horizontally. Horizontal joints need not be backed by steel framing.

**CGC INC** — Types AR, C, IP-AR, IP-X1, IP-X2, IPC-AR, SCX, SHX, ULX, WRC, WRX

**UNITED STATES GYPSUM CO** — Types AR, C, FRX-G, IP-AR, IP-X1, IP-X2, IPC-AR, SCX, SGX, SHX, ULX, WRC, WRX, USGX

**USG MEXICO S A DE C V** — Types AR, C, IP-AR, IP-X1, IP-X2, IPC-AR, SCX, SHX, ULX, WRC, WRX

##### System B — 2 Hr

Gypsum panels, with beveled, square or tapered edges, nom 1/2 in. or 5/8 in. thick, 48 in. or 1200 mm wide, applied vertically or horizontally in two layers. Inner or base layer attached to studs with 1 in. long Type S steel screws spaced 24 in. OC when installed vertically or 16 in. OC when installed horizontally. Outer or face layer attached to studs with 1-5/8 in. long Type S steel screws spaced 12 in. OC when installed vertically and staggered 12 in. from base layer screws or 8 in. OC when installed horizontally and staggered 8 in. from base layer screws. Horizontal joints between inner and outer layers staggered a min of 12 in. Horizontal joints need not be backed by steel framing. Vertical joints centered over studs and staggered 24 in.

**CGC INC** — 1/2 in. Type C, IP-X2, IPC-AR or WRC; 5/8 in. Types AR, C, IP-AR, IP-X1, IP-X2, IPC-AR, SCX, SHX, ULX, WRC, WRX

**UNITED STATES GYPSUM CO** — 1/2 in. Types C, IP-X2, IPC-AR, or WRC; 5/8 in. Types AR, C, FRX-G, IP-AR, IP-X1, IP-X2, IPC-AR, SCX, SGX, SHX, ULX, USGX, WRC, WRX

**USG MEXICO S A DE C V** — 1/2 in. Types C, IP-X2, IPC-AR or WRC; 5/8 in. Types AR, C, IP-AR, IP-X1, IP-X2, IPC-AR, SCX, SHX, ULX, WRC, WRX

##### System C — 2 Hr

Gypsum panels, with beveled, square or tapered edges, nom 3/4 in. thick, 48 in. or 1200 mm wide, applied vertically or horizontally, secured with 1-1/4 in. long Type S steel screws spaced 8 in. OC along vertical edges and 12 in. OC in the field when installed vertically or 8 in. OC along the vertical edges and in the field when installed horizontally. Horizontal joints need not be backed by steel framing. Screws along side joints offset 4 in. Requires min 4 in. deep framing per Items 1, 2 and 3. Requires min 3 in. thick mineral wool batts per Item 6.

**CGC INC** — Types IP-X3 or ULTRACODE

**UNITED STATES GYPSUM CO** — Types IP-X3 or ULTRACODE

**USG MEXICO S A DE C V** — Types IP-X3 or ULTRACODE

##### System D — 2 Hr

Gypsum panels, with beveled, square or tapered edges, nom 5/8 in. thick, 48 in. or 1200 mm wide, applied vertically

or horizontally, attached directly to studs with 1 in. long Type S steel screws spaced 24 in. when installed vertically or 16 in. OC when installed horizontally. Horizontal joints need not be backed by steel framing. Requires face layer of 1/2 or 5/8 in. thick cementitious backer units per Item 7 and min 1-1/2 in. thick mineral wool batts per Item 6.

**CGC INC** — Types AR, C, IP-AR, IP-X1, IP-X2, IPC-AR, SCX, SHX, ULX, WRC, WRX

**UNITED STATES GYPSUM CO** — Types AR, C, FRX-G, IP-AR, IP-X1, IP-X2, IPC-AR, SCX, SGX, SHX, ULX, USGX, WRC, WRX

**USG MEXICO S A DE C V** — Types AR, C, IP-AR, IP-X1, IP-X2, IPC-AR, SCX, SHX, ULX, WRC, WRX

#### System E — 2 Hr

Gypsum panels, with beveled, square or tapered edges, nom 1/2 in. or 5/8 in. thick, 48 in. or 1200 mm wide, applied vertically or horizontally, attached to studs with 1 in. long Type S steel screws spaced 12 in. OC when installed vertically or 8 in. when installed horizontally. Horizontal joints need not be backed by steel framing.

**CGC INC** — 1/2 in. Types C, IP-X2, IPC-AR; 5/8 in. Types AR, C, IP-AR, IP-X1, IP-X2, IPC-AR, SCX, SHX, ULX, WRC, WRX

**UNITED STATES GYPSUM CO** — 1/2 in. Types C, IP-X2, IPC-AR; 5/8 in. Types AR, C, FRX-G, IP-AR, IP-X1, IP-X2, IPC-AR, SCX, SGX, SHX, ULX, USGX, WRC, WRX.

**USG MEXICO S A DE C V** — 1/2 in. Types C, IP-X2, IPC-AR; 5/8 in. Types AR, C, IP-AR, IP-X1, IP-X2, IPC-AR, SCX, SHX, ULX, WRC, WRX

#### System F — 2 Hr

Gypsum panels, with beveled, square or tapered edges, nom 1/2 in. or 5/8 in. thick, 48 in. or 1200 mm wide, applied vertically in two layers. Inner or base layer attached to resilient furring channels (Item 2B) with 1 in. long Type S steel screws spaced 24 in. Outer or face layer attached to resilient furring channels (Item 2B) with 1-5/8 in. long Type S steel screws spaced 12 in. OC and staggered 12 in. from base layer screws. Joints between inner and outer layers staggered 24 in.

**CGC INC** — 1/2 in. Type C, IP-X2, IPC-AR or WRC; 5/8 in. Types AR, C, FRX-G, IP-AR, IP-X1, IP-X2, IPC-AR, SCX, SHX, ULX, WRC, WRX

**UNITED STATES GYPSUM CO** — 1/2 in. Type C, IP-X2, IPC-AR or WRC; 5/8 in. Types AR, C, FRX-G, IP-AR, IP-X1, IP-X2, IPC-AR, SCX, SGX, SHX, ULX, USGX, WRC, WRX

**USG MEXICO S A DE C V** — 1/2 in. Types C, IP-X2, IPC-AR or WRC; 5/8 in. Types AR, C, IP-AR, IP-X1, IP-X2, IPC-AR, SCX, SHX, ULX, WRC, WRX

#### System G — 3 Hr

Gypsum panels, with beveled, square or tapered edges, nom 5/8 in. thick, 48 in. or 1200 mm wide, applied vertically or horizontally in three layers. Inner or base layer attached to studs with 1 in. long Type S steel screws spaced 24 in. OC when installed vertically or 16 in OC when installed horizontally. Middle layer attached to studs with 1-5/8 in. long Type S steel screws spaced 24 in. when installed vertically or 16 in. OC when installed horizontally. Outer or face layer attached to studs with 2-1/4 in. long Type S steel screws spaced 16 in. when installed vertically or 12 in. OC when installed horizontally. Screws offset 6 in. from layer below. Horizontal joints on adjacent layers staggered a min of 12 in. Horizontal joints need not be backed by steel framing. Vertical joints centered over studs and staggered 24 in. on adjacent layers.

**CGC INC** — Types C, IP-X2, IPC-AR, WRC

**UNITED STATES GYPSUM CO** — Types C, IP-X2, IPC-AR, WRC

**USG MEXICO S A DE C V** — Types C, IP-X2, IPC-AR, WRC

#### System H — 3 Hr

Gypsum panels, with beveled, square or tapered edges, nom 5/8 in. thick, 48 in. or 1200 mm wide, applied vertically or horizontally, two layers over the flange of the "C" section of the studs, one layer over the flange of the "H" section of the studs. Inner or base layer attached to studs with 1 in. long Type S steel screws spaced 24 in. OC when installed vertically or 16 in. OC when installed horizontally. Face layer attached to studs with 1-5/8 in. long Type S steel screws spaced 16 in. when installed vertically or 12 in. OC when installed horizontally. Screws offset 6 in. from layer below. Horizontal joints on adjacent layers staggered a min of 12 in. Horizontal joints need not be backed by steel framing. Vertical joints centered over studs and staggered 24 in. on adjacent layers.

**CGC INC** — Types C, IP-X2, IPC-AR, WRC

**UNITED STATES GYPSUM CO** — Types C, IP-X2, IPC-AR, WRC

**USG MEXICO S A DE C V** — Types C, IP-X2, IPC-AR, WRC

#### **System I — 4 Hr**

Gypsum panels, with beveled, square or tapered edges, nom 3/4 in. thick, 4 ft wide (or 1200 mm for metric spacing) wallboard with square or tapered edges. Total of four layers to be used. First and second (inner) layers applied vertically or horizontally over the steel studs. Horizontal joints need not be backed by steel framing. When applied vertically, joints centered over studs and staggered min 24 in., otherwise all joints staggered min 12 in. First layer secured to studs with 1-1/4 in. long Type S self-drilling, self-tapping bugle-head steel screws spaced 24 in. OC. Second layer secured to studs with 2-1/4 in. long Type S self-drilling, self-tapping bugle-head steel screws spaced 12 in. OC. Third layer applied vertically over the furring channels (Item 2C) with a 1-1/4 in. long Type S self-drilling, self-tapping bugle-head steel screws spaced 12 in. OC. Fourth layer applied vertically or horizontally with 2-1/4 in. long Type S self-drilling, self-tapping bugle-head steel screws spaced 12 in. OC. When applied vertically, joints to be staggered min 24 in. from third layer, otherwise all joints staggered min 12 in.

**CGC INC** — Types IP-X3 or ULTRACODE

**UNITED STATES GYPSUM CO** — Types IP-X3 or ULTRACODE

**USG MEXICO S A DE C V** — Types IP-X3 or ULTRACODE

**4A. Gypsum Board\*** — (As an alternate to Item 4 Systems A, B, C, D, E, G, H, and I when used as the base layer, For direct attachment only) - Nom 5/8 in. or 3/4 in. thick lead backed gypsum panels with beveled, square or tapered edges, applied vertically. Vertical joints centered over 20 MSG steel studs and staggered min 1 stud cavity on opposite sides of studs. See Items 1, 2, 2A, 2B and 2D. Wallboard secured to studs with 1-1/4 in. long Type S-12 steel screws spaced 8 in. OC at perimeter and 12 in. OC in the field. For Joint Compound see Item 5. To be used with Lead Batten Strips (see Item 9) or Lead Discs or Tabs (see Item 10).

**RAY-BAR ENGINEERING CORP** — Type RB-LBG

**4B. Gypsum Board\*** — (As an alternate to Item 4 Systems A, B, C, D, E, G, H, and I when used as the base layer, For direct attachment only) - Nominal 5/8 in. thick lead backed gypsum panels with beveled, square or tapered edges, applied vertically. Vertical joints centered over studs and staggered min 1 stud cavity on opposite sides of studs. Wallboard secured to studs with 1-1/4 in. long Type S-12 (or #6 by 1-1/4 in. long bugle head fine driller) steel screws spaced 8 in. OC at perimeter and 12 in. OC in the field.

**NEW ENGLAND LEAD BURNING CO INC, DBA NELCO** — Type Nelco

**4C. Gypsum Board\*** — (As an alternate to Item 4 Systems A, B, C, D, E, G, H, and I when used as the base layer, For direct attachment only) - Nom 5/8 or 3/4 in. thick lead backed gypsum panels with beveled, square or tapered edges, applied vertically. Vertical joints centered over 20 MSG steel studs and staggered min 1 stud cavity on opposite sides of studs. See Items 1, 2, 2A, 2B and 2D. Wallboard secured to studs with 1-1/4 in. long Type S-12 steel screws spaced 8 in. OC at perimeter and 12 in. OC in the field. For Joint Compound see Item 5. To be used with Lead Batten Strips (see Item 9A) or Lead Discs (see Item 10A). Lead batten strips required behind vertical joints of lead backed gypsum wallboard and optional at remaining stud locations. Lead batten strips, min 2 in. wide, max 10 ft long with a max thickness of 0.140 in. placed on the face of studs and attached to the stud with two 1 in. long Type S-8 pan head steel screws, one at the top of the strip and one at the bottom of the strip.

**MAYCO INDUSTRIES INC** — Type X-Ray Shielded Gypsum

**4D. Gypsum Board\*** — (As an alternate to Item 4 Systems A, B, C, D, E, G, H, and I when used as the base layer, For direct attachment only). Nom 5/8 in. thick lead backed gypsum panels with beveled, square or tapered edges, applied vertically. Vertical joints centered over studs and staggered min 1 stud cavity on opposite sides of studs. Wallboard secured to studs with 1-1/4 in. long Type S-12 steel screws gypsum panel steel screws spaced 8 in. OC at perimeter and 12 in. OC in the field. Lead batten strips required behind vertical joints of lead backed gypsum wallboard

and optional at remaining stud locations. Lead batten strips, min 2 in. wide, max 8 ft long with a max thickness of 0.14 in. placed on the face of studs and attached to the stud with construction adhesive and two 1 in. long Type S-12 pan head steel screws, one at the top of the strip and one at the bottom of the strip. Lead discs, nominal 3/8 in. diam by max 0.085 in. thick. Compression fitted or adhered over the screw heads. Lead batten strips and discs to have a purity of 99.9% meeting the Federal specification QQ-L-201f, Grade "C".

**RADIATION PROTECTION PRODUCTS INC** — Type RPP - Lead Lined Drywall

**5. Joint Tape and Compound** — (Not Shown)

**Systems A, B, C, E, F, G, H, I**

Joints on outer layers of gypsum boards (Item 4 and 4A) covered with paper tape and joint compound. Paper tape and joint compound may be omitted when gypsum boards are supplied with square edges. Exposed screw heads covered with joint compound.

**6. Batts and Blankets\*** —

**Systems A, B, E, F, G, H, I**

(Optional) — Mineral wool or glass fiber batts partially or completely filling stud cavity. Any mineral wool or glass fiber batt mineral bearing the UL Classification Marking as to Fire Resistance.

**Systems C & D**

Min 3 in. (System C) and min 1-1/2 in. (System D) thick mineral wool batts, friction fitted between the studs and floor and ceiling runners.

**ROXUL INC** — Type AFB

**THERMAFIBER INC** — Type SAFB

**7. Cementitious Backer Units\*** — (System D) — Nom 1/2 or 5/8 in. thick panels, square edge, attached to studs over gypsum wallboard with 1-5/8 in. long, Type S-12, corrosion resistant steel screws spaced 8 in. OC and staggered 8 in. from gypsum wall board screws. Joints covered with glass fiber mesh tape. Vertical joints staggered one stud cavity from gypsum wallboard joints. Horizontal joints staggered a min of 12 in. from the gypsum wallboard joints.

**UNITED STATES GYPSUM CO** — Type DCB

**8. Laminating Adhesive\*** — (Optional, Not Shown) — Used to bond outer layer of Cementitious Backer Units (Item 7) to inner layers of Gypsum Board (Item 4) in System D. ANSI A136.1 Type 1 organic adhesive applied with 1/4 in. square notched trowel. See Adhesives (BYWR) in the Fire Resistance Directory or Adhesives (BJLZ) in the Building Materials Directory for names of Classified companies.

**9. Lead Batten Strips** — (Not Shown, For Use With Item 4A) - Lead batten strips, min 1-1/2 in. wide, max 10 ft long with a max thickness of 0.125 in. Strips placed on the interior face of studs and attached from the exterior face of the stud with two 1 in. long Type S-12 pan head steel screws, one at the top of the strip and one at the bottom of the strip. Lead batten strips to have a purity of 99.9% meeting the Federal specification QQ-L-201f, Grade "C". Lead batten strips required behind vertical joints of lead backed gypsum wallboard (Item 4A) and optional at remaining stud locations. Required behind vertical joints.

**9A. Lead Batten Strips** — (Not Shown, for use with Item 4C) Lead batten strips, 2 in. wide, max 10 ft long with a max thickness of 0.140 in. Strips placed on the face of studs and attached to the stud with two min. 1 in. long min. Type S-8 pan head steel screws, one at the top of the strip and one at the bottom of the strip or with one min. 1 in. long min. Type S-8 pan head steel screw at the top of the strip. Lead batten strips to have a purity of 99.5% meeting the Federal specification QQ-L-201f, Grades "B, C or D".. Lead batten strips required behind vertical joints of lead backed gypsum wallboard (Item 6) and optional at remaining stud locations.

**10. Lead Discs or Tabs** — (Not Shown, For Use With Item 4A) - Used in lieu of or in addition to the lead batten strips (Item 9) or optional at other locations - Max 3/4 in. diam by max 0.125 in. thick lead discs compression fitted or adhered over steel screw heads or max 1/2 in. by 1-1/4 in. by max 0.125 in. thick lead tabs placed on gypsum boards (Item 4A) underneath screw locations prior to the installation of the screws. Lead discs or tabs to have a purity of 99.9% meeting the Federal specification QQ-L-201f, Grade "C".

**10A. Lead Discs** — (Not Shown, for use with Item 4C) Max 5/16 in. diam by max 0.140 in. thick lead discs compression fitted or adhered over steel screw heads. Lead discs to have a purity of 99.5% meeting the Federal Specification QQ-L-201f, Grades "B, C or D".

**11. Lead Batten Strips** — (Not Shown, For Use With Item 4B) Lead batten strips, 2 in. wide, max 10 ft long with a max thickness of 0.142 in. Strips placed on the face of studs and attached to the stud with two min. 1 in. long min. Type S-8 pan head steel screws, one at the top of the strip and one at the bottom of the strip or with one min. 1 in. long min. Type S-8 pan head steel screw at the top of the strip. Lead batten strips to have a purity of 99.9% meeting the Federal specification QQ-L-201f, Grade "C". Lead batten strips required behind vertical joints of lead backed gypsum wallboard (Item 4B) and optional at remaining stud locations.

**12. Lead Tabs** — (Not Shown, For Use With Item 4B) 2 in. wide, 5 in. long with a max thickness of 0.142 in. Tabs

friction-fit around front face of stud, the stud folded back flange, and the back face of the stud. Tabs required at each location where a screw (that secures the gypsum boards, Item 4B) will penetrate the steel stud. Lead tabs to have a purity of 99.9% meeting the Federal specification QQ-L-201f, Grade "C". Lead tabs may be held in place with standard adhesive tape if necessary.

**\* Indicates such products shall bear the UL or cUL Certification Mark for jurisdictions employing the UL or cUL Certification (such as Canada), respectively.**

Last Updated on 2015-03-16

---

[Questions?](#)

[Print this page](#)

[Terms of Use](#)

[Page Top](#)

© 2015 UL LLC

When the UL Leaf Mark is on the product, or when the word "Environment" is included in the UL Mark, please search the [UL Environment database](#) for additional information regarding this product's certification.

The appearance of a company's name or product in this database does not in itself assure that products so identified have been manufactured under UL's Follow-Up Service. Only those products bearing the UL Mark should be considered to be Certified and covered under UL's Follow-Up Service. Always look for the Mark on the product.

UL permits the reproduction of the material contained in the Online Certification Directory subject to the following conditions: 1. The Guide Information, Assemblies, Constructions, Designs, Systems, and/or Certifications (files) must be presented in their entirety and in a non-misleading manner, without any manipulation of the data (or drawings). 2. The statement "Reprinted from the Online Certifications Directory with permission from UL" must appear adjacent to the extracted material. In addition, the reprinted material must include a copyright notice in the following format: "© 2015 UL LLC".



## Design No. U419 BXUV.U419 Fire Resistance Ratings - ANSI/UL 263

[Page Bottom](#)

### Design/System/Construction/Assembly Usage Disclaimer

- Authorities Having Jurisdiction should be consulted in all cases as to the particular requirements covering the installation and use of UL Certified products, equipment, system, devices, and materials.
- Authorities Having Jurisdiction should be consulted before construction.
- Fire resistance assemblies and products are developed by the design submitter and have been investigated by UL for compliance with applicable requirements. The published information cannot always address every construction nuance encountered in the field.
- When field issues arise, it is recommended the first contact for assistance be the technical service staff provided by the product manufacturer noted for the design. Users of fire resistance assemblies are advised to consult the general Guide Information for each product category and each group of assemblies. The Guide Information includes specifics concerning alternate materials and alternate methods of construction.
- Only products which bear UL's Mark are considered Certified.

### BXUV - Fire Resistance Ratings - ANSI/UL 263

### BXUV7 - Fire Resistance Ratings - CAN/ULC-S101 Certified for Canada

[See General Information for Fire-resistance Ratings - ANSI/UL 263](#)

[See General Information for Fire Resistance Ratings - CAN/ULC-S101 Certified for Canada](#)

## Design No. U419

February 25, 2015

**Nonbearing Wall Ratings — 1, 2, 3 or 4 Hr (See Items 4 & 5)**

**\* Indicates such products shall bear the UL or cUL Certification Mark for jurisdictions employing the UL or cUL Certification (such as Canada), respectively.**

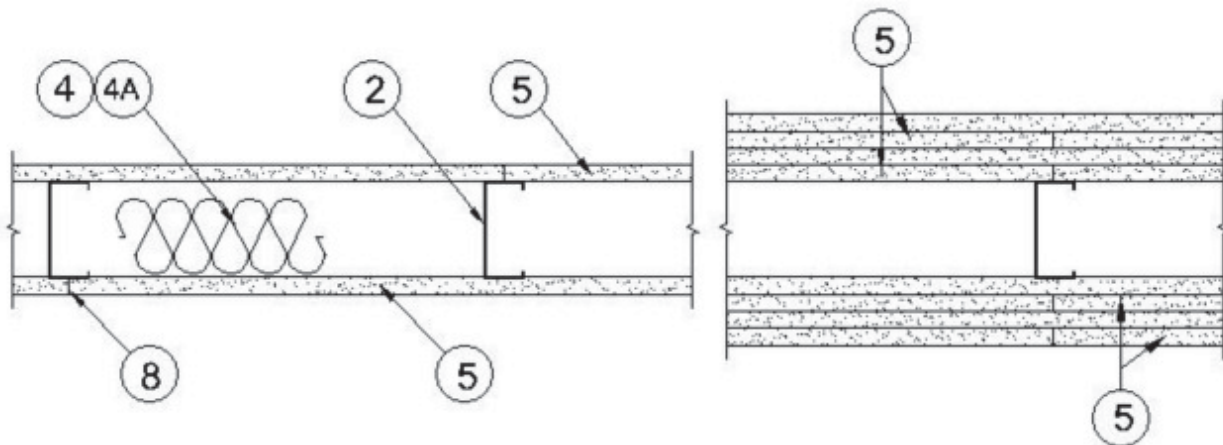

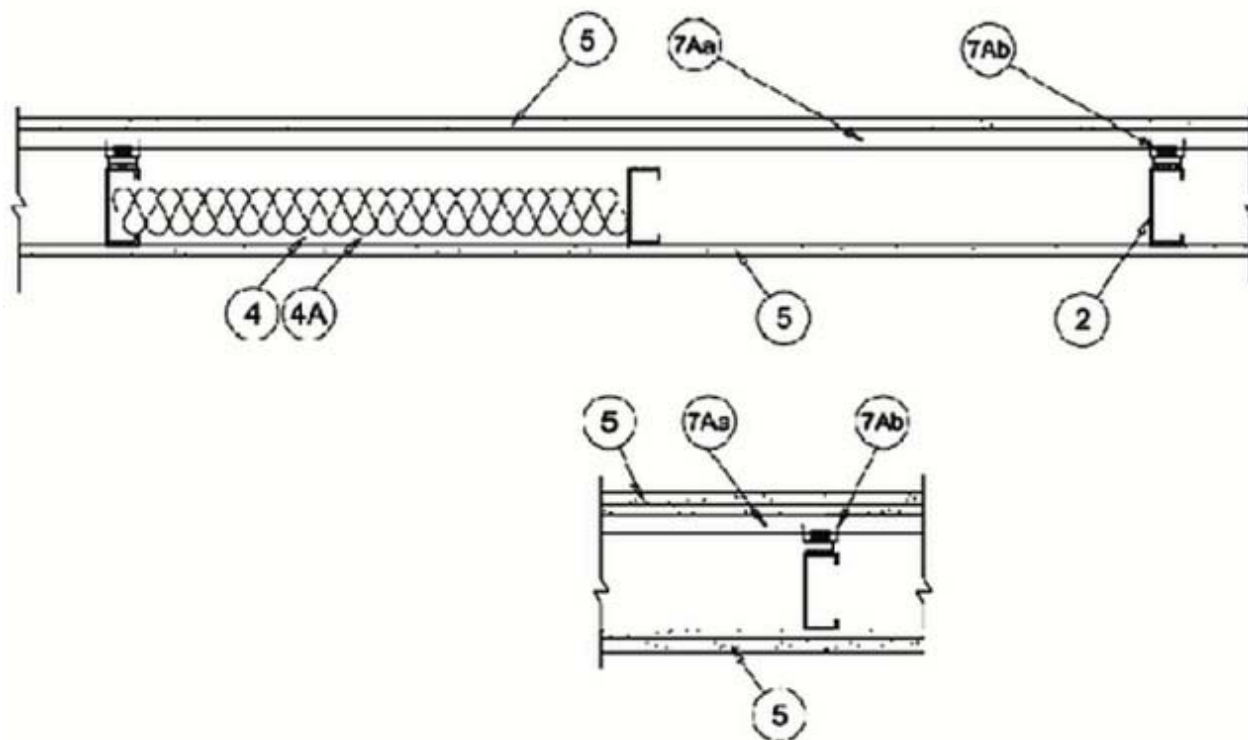

1. **Floor and Ceiling Runners** — (Not shown) — For use with Item 2 - Channel shaped, fabricated from min 25 MSG corrosion-protected steel, min depth to accommodate stud size, with min 1-1/4 in. long legs, attached to floor and ceiling with fasteners 24 in. OC max.

1A. **Framing Members\* - Floor and Ceiling Runner** — Not shown - In lieu of Item 1 — For use with Item 2B, proprietary channel shaped runners, 3-5/8 in. deep attached to floor and ceiling with fasteners 24 in. OC max.

**CALIFORNIA EXPANDED METAL PRODUCTS CO** — Viper25™ Track

**CRACO MFG INC** — SmartTrack25™

**MARINO/WARE, DIV OF WARE INDUSTRIES INC** — Viper25™ Track

**PHILLIPS MFG CO L L C** — Viper25™ Track

1B. **Framing Members\* - Floor and Ceiling Runner** — Not shown - In lieu of Item 1 — For use with Item 2C, proprietary channel shaped runners, 1-1/4 in. wide by 3-5/8 in. deep fabricated from min 0.020 in. thick galv steel, attached to floor and ceiling with fasteners spaced 24 in. OC max.

**CALIFORNIA EXPANDED METAL PRODUCTS CO** — Viper20™ Track

**MARINO/WARE, DIV OF WARE INDUSTRIES INC** — Viper20™ Track

**PHILLIPS MFG CO L L C** — Viper20™ Track

1C. **Framing Members\*— Floor and Ceiling Runners** — (Not shown) — In lieu of Item 1 - Channel shaped, attached to floor and ceiling with fasteners 24 in. OC. max.

**ALLSTEEL & GYPSUM PRODUCTS INC** — Type SUPREME Framing System

**CONSOLIDATED FABRICATORS CORP, BUILDING PRODUCTS DIV** — Type SUPREME Framing System

**QUAIL RUN BUILDING MATERIALS INC** — Type SUPREME Framing System

**SCAFCO STEEL STUD MANUFACTURING CO** — Type SUPREME Framing System

**STEEL CONSTRUCTION SYSTEMS INC** — Type SUPREME Framing System

**UNITED METAL PRODUCTS INC** — Type SUPREME Framing System

1D. **Floor and Ceiling Runners** — (Not shown)—For use with Item 2A- Channel shaped, fabricated from min 20 MSG corrosion-protected or galv steel, min depth to accommodate stud size, with min 1 in. long legs, attached to floor and ceiling with fasteners spaced max 24 in. OC.

1E. **Framing Members\*— Floor and Ceiling Runners** — (Not shown, As an alternate to Item 1) — For use with Items 2E, 5F or 5G or 5I only, channel shaped, fabricated from min. 0.015 in. (min bare metal thickness) galvanized steel, attached to floor and ceiling with fasteners 24 in. OC. max.

**CLARKDIETRICH BUILDING SYSTEMS** — CD ProTRAK

**DMFCWBS L L C** — ProTRAK

**MBA METAL FRAMING** — ProTRAK

**RAM SALES L L C** — Ram ProTRAK

**STEEL STRUCTURAL SYSTEMS L L C** — Tri-S ProTRAK

1F. **Framing Members\* - Floor and Ceiling Runner** — Not shown - In lieu of Item 1 — For use with Item 2F, proprietary channel shaped runners, minimum width to accommodate stud size, with 1- 1/8 in. long legs fabricated from min 0.015 in. (min bare metal thickness) galv steel, attached to floor and ceiling with fasteners spaced 24 in. OC max.

**SUPER STUD BUILDING PRODUCTS** — The Edge

1G. **Framing Members\* - Floor and Ceiling Runner** — For use with Item 2G, proprietary channel shaped runners, minimum width to accommodate stud size attached to floor and ceiling with fasteners 24 in. OC max.

**STUDCO BUILDING SYSTEMS** — CROCSTUD Track

1H. **Floor and Ceiling Runners** — (Not shown) — Channel shaped, fabricated from min 0.02 in. galv steel, min width to accommodate stud size, with min 1 in. long legs, for use with studs specified below and fabricated from min 0.02 in. galv steel or thicker, attached to floor and ceiling with fasteners spaced max 24 in. OC.

**MARINO/WARE, DIV OF WARE INDUSTRIES INC** — Viper20™ Track VT100.

1I. **Framing Members\*— Floor and Ceiling Runners** — (Not shown, As an alternate to Item 1) — For use with Items 2H, channel shaped, fabricated from min. 0.015 in. (min bare metal thickness) galvanized steel, attached to floor and ceiling with fasteners 24 in. OC. max.

**TELLING INDUSTRIES L L C** — TRUE-TRACK™

1J. **Framing Members\* - Floor and Ceiling Runner** — Not shown - In lieu of Item 1 — For use with Item 2I, proprietary channel shaped runners, 3-5/8 in. deep attached to floor and ceiling with fasteners 24 in. OC max.

**TELLING INDUSTRIES L L C** — Viper25™ Track

1K. **Framing Members\* - Floor and Ceiling Runner** — Not shown - In lieu of Item 1 — For use with Item 2J, proprietary channel shaped runners, 1-1/4 in. wide by 3-5/8 in. deep fabricated from min 0.020 in. thick galv steel, attached to floor and ceiling with fasteners spaced 24 in. OC max.

**TELLING INDUSTRIES L L C** — Viper20™ Track



2. **Steel Studs** — Channel shaped, fabricated from min 25 MSG corrosion-protected steel, min depth as indicated under Item 5, spaced a max of 24 in. OC. Studs to be cut 3/8 to 3/4 in. less than assembly height.

2A. **Steel Studs** — (As an alternate to Item 2, For use with Items 5B, 5E, 5H and 5J) Channel shaped, fabricated from min 20 MSG corrosion-protected or galv steel, 3-1/2 in. min depth, spaced a max of 16 in. OC. Studs friction-fit into floor and ceiling runners. Studs to be cut 5/8 to 3/4 in. less than assembly height.

2B. **Framing Members\* - Steel Studs** — (As an alternate to Item 2, For use with Items 5C, 5I or 5K) - Proprietary channel shaped studs, 3-5/8 in. deep spaced a max of 24 in. OC. Studs to be cut 3/4 in less than the assembly height and installed with a 1/2 in. gap between the end of the stud and track at the bottom of the wall. For direct attachment of gypsum board only.

**CALIFORNIA EXPANDED METAL PRODUCTS CO** — Viper25™

**CRACO MFG INC** — SmartStud25™

**MARINO/WARE, DIV OF WARE INDUSTRIES INC** — Viper25™

**PHILLIPS MFG CO L L C** — Viper25™

2C. **Framing Members\* - Steel Studs** — Not shown - In lieu of Item 2 — proprietary channel shaped steel studs, min depth as indicated under Item 5, spaced a max if 24 in. OC, fabricated from min 0.020 in. thick galv steel. Studs cut 3/8 in. to 3/4 in. less in lengths than assembly heights.

**CALIFORNIA EXPANDED METAL PRODUCTS CO** — Viper20™

**MARINO/WARE, DIV OF WARE INDUSTRIES INC** — Viper20™

**PHILLIPS MFG CO L L C** — Viper20™

2D. **Framing Members\*— Steel Studs** — In lieu of Item 2 - Channel shaped studs, min depth as indicated under Item 5, spaced a max of 24 in. OC. Studs to be cut 3/4 in. less than assembly height.

**ALLSTEEL & GYPSUM PRODUCTS INC** — Type SUPREME Framing System

**CONSOLIDATED FABRICATORS CORP, BUILDING PRODUCTS DIV** — Type SUPREME Framing System

**QUAIL RUN BUILDING MATERIALS INC** — Type SUPREME Framing System

**SCAFCO STEEL STUD MANUFACTURING CO** — Type SUPREME Framing System

**STEEL CONSTRUCTION SYSTEMS INC** — Type SUPREME Framing System

**UNITED METAL PRODUCTS INC** — Type SUPREME Framing System

2E. **Framing Members\*— Steel Studs** — (Not shown, As an alternate to Item 2) —For use with Items 5F or 5G or 5I only, channel shaped studs, min depth as indicated under Item 5F, 5G or 5I, fabricated from min. 0.015 in. (min bare metal thickness) galvanized steel, spaced a max of 24 in. OC. Studs to be cut 3/4 in. less than assembly height.

**CLARKDIETRICH BUILDING SYSTEMS** — CD ProSTUD

**DMFCWBS L L C** — ProSTUD

**MBA METAL FRAMING** — ProSTUD

**RAM SALES L L C** — Ram ProSTUD

**STEEL STRUCTURAL SYSTEMS L L C — Tri-S ProSTUD**

2F. **Framing Members\* - Steel Studs** — Not shown - In lieu of Item 2 — proprietary channel shaped steel studs, minimum width indicated under Item 5, 1-1/4 in. deep fabricated from min 0.015 in. (min bare metal thickness) galvanized steel. Studs 3/8 in. to 3/4 in. less in lengths than assembly heights.

**SUPER STUD BUILDING PRODUCTS — The Edge**

2G. **Framing Members\* - Steel Studs** — Not shown - In lieu of Item 2 - proprietary channel shaped studs, minimum width indicated under Item 5, Studs to be cut 3/8 to 3/4 in less than the assembly height.

**STUDCO BUILDING SYSTEMS — CROCSTUD**

2H. **Framing Members\*— Steel Studs** — (Not shown, As an alternate to Item 2) — Fabricated from min. 0.015 in. (min bare metal thickness) galvanized steel, spaced a max of 24 in. OC. Studs to be cut 3/4 in. less than assembly height.

**TELLING INDUSTRIES L L C — TRUE-STUD™**

2I. **Framing Members\* - Steel Studs** — (As an alternate to Item 2, For use with Items 5C or 5L) - Proprietary channel shaped studs, 3-5/8 in. deep spaced a max of 24 in. OC. Studs to be cut 3/4 in less than the assembly height and installed with a 1/2 in. gap between the end of the stud and track at the bottom of the wall. For direct attachment of gypsum board only.

**TELLING INDUSTRIES L L C — Viper25™**

2J. **Framing Members\* - Metal Studs** — Not shown - In lieu of Item 2 — proprietary channel shaped steel studs, min depth as indicated under Item 5, spaced a max if 24 in. OC, fabricated from min 0.020 in. thick galv steel. Studs cut 3/8 in. to 3/4 in. less in lengths than assembly heights

**TELLING INDUSTRIES L L C — Viper20™**

2K. **Framing Members\*— Steel Studs** — As an alternate to Item 2 - For use with Item 1, channel shaped studs, fabricated from min 25 MSG corrosion-protected steel, min depth as indicated under Item 5, spaced a max of 24 in. OC. Studs to be cut 3/8 to 3/4 in. less than assembly height.

**EB MÉTAL INC — EB Stud**

2L. **Framing Members\*— Steel Studs** — As an alternate to Item 2 - For use with Item 1, channel shaped studs, fabricated from min 25 MSG corrosion-protected steel, min depth as indicated under Item 5, spaced a max of 24 in. OC. Studs to be cut 3/8 to 3/4 in. less than assembly height.

**OLMAR SUPPLY INC — PRIMESTUD**

3. **Wood Structural Panel Sheathing** — (Optional, For use with Item 5 Only.)- (Not Shown) - 4 ft wide, 7/16 in. thick oriented strand board (OSB) or 15/32 in. thick structural 1 sheathing (plywood) complying with DOC PS1 or PS2, or APA Standard PRP-108, manufactured with exterior glue, applied horizontally or vertically to the steel studs. Vertical joints centered on studs, and staggered one stud space from wallboard joints. Attached to studs with flat-head self-drilling tapping screws with a min. head diam. of 0.292 in. at maximum 6 in. OC. in the perimeter and 12 in. OC. in the field. When used, fastener lengths for gypsum panels increased by min. 1/2 in.

4. **Batts and Blankets\*** — (Required as indicated under Item 5) — Mineral wool batts, friction fitted between studs and runners. Min nom thickness as indicated under Item 5. See **Batts and Blankets (BKNV or BZJZ) Categories** for names of Classified companies.

4A. **Batts and Blankets\*** — (Optional) — Placed in stud cavities, any glass fiber or mineral wool insulation bearing the UL Classification Marking as to Surface Burning Characteristics and/or Fire Resistance. See **Batts and Blankets (BKNV or BZJZ) Categories** for names of Classified companies.

4B. **Batts and Blankets\*** — Placed in stud cavities, any 3-1/2 in. thick glass fiber insulation bearing the UL Classification Marking as to Surface Burning Characteristics and/or Fire Resistance. See **Batts and Blankets (BKNV or BZJZ) Categories** for names of Classified companies.

5. **Gypsum Board\*** — Gypsum panels with beveled, square or tapered edges, applied vertically or horizontally. Vertical joints centered over studs and staggered one stud cavity on opposite sides of studs. Vertical joints in adjacent layers (multilayer systems) staggered one stud cavity. Horizontal joints need not be backed by steel framing. Horizontal edge joints and horizontal butt joints on opposite sides of studs need not be staggered. Horizontal edge joints and horizontal butt joints in adjacent layers (multilayer systems) staggered a min of 12 in. The thickness and number of layers for the 1 hr, 2 hr, 3 hr and 4 hr ratings are as follows:

**Gypsum Board Protection on Each Side of Wall**

Rating, Hr	Min Stud Depth, in. Items 2, 2C, 2D, 2F and 2G	No. of Layers & Thkns of Panel	Min Thkns of Insulation (Item 4)
1	3-1/2	1 layer, 5/8 in. thick	Optional
1	2-1/2	1 layer, 1/2 in. thick	1-1/2 in.
1	1-5/8	1 layer, 3/4 in. thick	Optional
2	1-5/8	2 layers, 1/2 in. thick	Optional
2	1-5/8	2 layers, 5/8 in. thick	Optional
2	3-1/2	1 layer, 3/4 in. thick	3 in.
3	1-5/8	3 layers, 1/2 in. thick	Optional
3	1-5/8	2 layers, 3/4 in. thick	Optional
3	1-5/8	3 layers, 5/8 in. thick	Optional
4	1-5/8	4 layers, 5/8 in. thick	Optional
4	1-5/8	4 layers, 1/2 in. thick	Optional
4	2-1/2	2 layers, 3/4 in. thick	2 in.

**CGC INC** — 1/2 in. thick Type C, IP-X2 or IPC-AR; WRC, 5/8 in. thick Type AR, C, IP-AR, IP-X1, IP-X2, IPC-AR, SCX, SHX, WRX or WRC; 3/4 in. thick Types IP-X3 or ULTRACODE

**UNITED STATES GYPSUM CO** — 1/2 in. thick Type C, IP-X2, IPC-AR or WRC; 5/8 in. thick Type SCX, SGX, SHX, WRX, IP-X1, AR, C, WRC, FRX-G, IP-AR, IP-X2, IPC-AR ; 3/4 in. thick Types IP-X3 or ULTRACODE

**USG MEXICO S A DE C V** — 1/2 in. thick Type C, IP-X2, IPC-AR or WRC; 5/8 in. thick Type AR, C, IP-AR, IP-X1, IP-X2, IPC-AR, SCX, SHX, WRX, WRC or; 3/4 in. thick Types IP-X3 or ULTRACODE

When Item 7B, Steel Framing Members\*, is used, Nonbearing Wall Rating is limited to 1 Hr. Min. stud depth is 3-1/2 in., min. thickness of insulation (Item 4) is 3 in., and two layers of gypsum board panels (1/2 in. or 5/8 in. thick) shall be attached to furring channels as described in Item 6. One layer of gypsum board panels (1/2 in. or 5/8 in. thick) attached to opposite side of stud without furring channels as described in Item 6.

5A. **Gypsum Board\*** — (As an alternate to Item 5) — 5/8 in. thick, 24 to 54 in. wide, applied horizontally as the outer layer to one side of the assembly. Secured as described in Item 6.

**CGC INC** — Type SHX.

**UNITED STATES GYPSUM CO** — Type FRX-G, SHX.

**USG MEXICO S A DE C V** — Type SHX.

5B. **Gypsum Board\*** — (Not Shown) - As an alternate to Item 5 when used as the base layer on one or both sides of wall when 5/8 in or 3/4 in. thick products are specified. For direct attachment only to steel studs Item 2A, (not to be used with Item 3) - Nom 5/8 in. or 3/4 in. may be used as alternate to all 5/8 in. or 3/4 in. shown in Item 5, Wallboard Protection on Each Side of Wall table. Nom 5/8 in. or 3/4 in. thick lead backed gypsum panels with beveled, square or tapered edges, applied vertically. Vertical joints centered over studs and staggered min 1 stud cavity on opposite sides of studs. Gypsum board secured to 20 MSG steel studs Item 2A with 1-1/4 in. long Type S-12 steel screws spaced 8 in. OC at perimeter and 12 in. OC in the field. To be used with Lead Batten Strips (see Item 11) or Lead Discs or Tabs (see Item 12).

**RAY-BAR ENGINEERING CORP** — Type RB-LBG

5C. **Gypsum Board\*** — (For Use With Item 2B) Rating Limited to 1 Hour. 5/8 in. thick, 48 in. wide, Gypsum panels with beveled, square or tapered edges, applied vertically or horizontally. (Vertical Application) - The gypsum board is to be installed on each side of the studs with 1 in. long Type S coated steel screws spaced 8 in. OC starting 4 in. from the edge of the board at the vertical edges and 12 in. OC starting 6 in. from the edge of the board at the center of each board. Gypsum boards are to be secured to the top and bottom track with screws spaced 8 in. OC starting 4 in. from

the board edge. Fasteners shall not penetrate through both the stud and the track at the same time. Vertical joints are to be centered over studs and staggered one stud cavity on opposite sides of studs. (Horizontal Application) - The gypsum board is to be installed on each side of the studs with 1 in. long Type S coated steel screws spaced 8 in. OC starting 4 in. from the edge of the board at the vertical edges and 12 in. OC starting 6 in. from the edge of the board at the center of each board. Gypsum boards are to be secured to the top and bottom track with screws spaced 8 in. OC starting 4 in. from the board edge. Fasteners shall not penetrate through both the stud and the track at the same time. All horizontal joints are to be backed as outlined under section VI of Volume 1 in the Fire Resistive Directory.

**CGC INC** — Type SCX.

**UNITED STATES GYPSUM CO** — Type SCX, SGX.

**USG MEXICO S A DE C V** — Type SCX.

5D. **Gypsum Board\*** — (As an alternate to Item 5) — 5/8 in. thick, 48 in. wide, applied vertically or horizontally. Secured as described in Item 6. For use with Items 1 and 2 only.

**UNITED STATES GYPSUM CO** — Type USGX.

5E. **Gypsum Board\*** — (Not Shown) - (As an alternate to Item 5 when used as the base layer on one or both sides of wall when 1/2 in. or 5/8 in thick products are specified, For direct attachment only to steel studs Item 2A, not to be used with Item 3). Nominal 5/8 in. thick lead backed gypsum panels with beveled, square or tapered edges, applied vertically. Vertical joints centered over studs and staggered min 1 stud cavity on opposite sides of studs. Wallboard secured to studs with 1-1/4 in. long Type S-12 (or No. 6 by 1-1/4 in. long bugle head fine driller) steel screws spaced 8 in. OC at perimeter and 12 in. OC in the field.

**NEW ENGLAND LEAD BURNING CO INC, DBA NELCO** — Nelco

5F. **Gypsum Board\*** — (As an alternate to Item 5) — For use with Items 1E and 2E and limited to 1 Hour Rating only, Gypsum panels with beveled, square or tapered edges, applied vertically, and fastened to the steel studs with 1 in. long Type S screws spaced 8 in. OC along vertical and bottom edges and 12 in. OC in the field. Vertical joints centered over studs and staggered one stud cavity on opposite sides of studs. Steel stud depth shall be a minimum 3-5/8 in.

**UNITED STATES GYPSUM CO** — 5/8 in. thick Type SCX, SGX.

5G. **Gypsum Board\*** — (As an alternate to Item 5) — For use with Items 1E and 2E only, Gypsum panels with beveled, square or tapered edges, applied vertically or horizontally, as specified in the table below and fastened to the steel studs as described in Item 6. Vertical joints centered over studs and staggered one stud cavity on opposite sides of studs. Vertical joints in adjacent layers (multilayer systems) staggered one stud cavity. Horizontal joints need not be backed by steel framing. Horizontal edge joints and horizontal butt joints on opposite sides of studs need not be staggered. Horizontal edge joints and horizontal butt joints in adjacent layers (multilayer systems) staggered a min of 12 in. The thickness and number of layers for the 2 hr, 3 hr and 4 hr ratings are as follows:

**Gypsum Board Protection on Each Side of Wall**

Rating, Hr	Min Stud Depth, in. Item 2E	No. of Layers & Thickness of Panel	Min Thkns of Insulation (Item 4)
2	1-5/8	2 layers, 1/2 in. thick	Optional
2	1-5/8	2 layers, 5/8 in. thick	Optional
3	1-5/8	3 layers, 1/2 in. thick	Optional
3	1-5/8	3 layers, 5/8 in. thick	Optional
4	1-5/8	4 layers, 5/8 in. thick	Optional
4	1-5/8	4 layers, 1/2 in. thick	Optional

**CGC INC** — 1/2 in. thick Type C, IP-X2 or IPC-AR; 5/8 in. thick Type AR, C, IP-AR, IP-X1, IP-X2, IPC-AR, SCX, SHX, or; 3/4 in. thick Types IP-X3 or ULTRACODE

**UNITED STATES GYPSUM CO** — 1/2 in. thick Type C, IP-X2, IPC-AR or; 5/8 in. thick Type SCX, SGX, SHX, IP-X1, AR, C, , FRX-G, IP-AR, IP-X2, IPC-AR ; 3/4 in. thick Types IP-X3 or ULTRACODE

**USG MEXICO S A DE C V** — 1/2 in. thick Type C, IP-X2, IPC-AR or; 5/8 in. thick Type AR, C, IP-AR, IP-X1, IP-X2,

IPC-AR, SCX, SHX, or; 3/4 in. thick Types IP-X3 or ULTRACODE

5H. **Gypsum Board\*** — (Not Shown) - (As an alternate to Item 5 when used as the base layer on one or both sides of wall when 5/8 or 3/4 in thick products are specified. For direct attachment only to steel studs Item 2A, (not to be used with Item 3) - Nom 5/8 or 3/4 in. may be used as alternate to all 5/8 or 3/4 in. shown in Item 5, Wallboard Protection on Each Side of Wall table. Nom 5/8 or 3/4 in. thick lead backed gypsum panels with beveled, square or tapered edges, applied vertically. Vertical joints centered over 20 MSG steel studs and staggered min 1 stud cavity on opposite sides of studs. Wallboard secured to studs with 1-1/4 in. long Type S-12 steel screws spaced 8 in. OC at perimeter and 12 in. OC in the field. Gypsum board secured to 20 MSG steel studs Item 2B with 1-1/4 in. long Type S-12 steel screws spaced 8 in. OC at perimeter and 12 in. OC in the field. For Joint Compound see Item 5. To be used with Lead Batten Strips (see Item 11A) or Lead Discs (see Item 12A).

**MAYCO INDUSTRIES INC** — Type X-Ray Shielded Gypsum

5I. **Gypsum Board\*** — (As an alternate to Item 5) - Nom. 5/8 in. thick gypsum panels with beveled, square or tapered edges installed as described in Item 5. Steel stud minimum depth shall be as indicated in Item 5.

**CGC INC** — Type ULX

**UNITED STATES GYPSUM CO** — Type ULX

**USG MEXICO S A DE C V** — Type ULX

5J. **Gypsum Board\*** — (Not Shown) - (As an alternate to Item 5 when used as the base layer on one or both sides of wall when 1/2 in. or 5/8 in thick products are specified, For direct attachment only to steel studs Item 2A, not to be used with Item 3). Nom 5/8 in. thick lead backed gypsum panels with beveled, square or tapered edges, applied vertically. Vertical joints centered over studs and staggered min 1 stud cavity on opposite sides of studs. Wallboard secured to studs with 1-1/4 in. long Type S-12 steel screws gypsum panel steel screws spaced 8 in. OC at perimeter and 12 in. OC in the field. Lead batten strips required behind vertical joints of lead backed gypsum wallboard and optional at remaining stud locations. Lead batten strips, min 2 in. wide, max 8 ft long with a max thickness of 0.14 in. placed on the face of studs and attached to the stud with construction adhesive and two 1 in. long Type S-12 pan head steel screws, one at the top of the strip and one at the bottom of the strip. Lead discs, nominal 3/8 in. diam by max 0.085 in. thick. Compression fitted or adhered over the screw heads. Lead batten strips and discs to have a purity of 99.9% meeting the Federal specification QQ-L-201f, Grade "C".

**RADIATION PROTECTION PRODUCTS INC** — Type RPP - Lead Lined Drywall

5K. **Gypsum Board\*** — Nom. 5/8 in. thick gypsum panels with beveled, square or tapered edges installed as described in Item 5. Insulation (Item 4B) required. The steel stud size and type and number of layers are as follows:

#### Gypsum Board Protection on Each Side of Wall

Rating, Hr	Min Stud Depth, in. Items 2, 2B	No. of Layers & Thickness of Panel
1	3-5/8	1 layer, 5/8 in. thick

**UNITED STATES GYPSUM CO** — 5/8 in. thick Type ULIX

6. **Fasteners** — (Not shown) — For use with Items 2 and 2F - Type S or S-12 steel screws used to attach panels to studs (Item 2) or furring channels (Item 7). **Single layer systems:** 1 in. long for 1/2 and 5/8 in. thick panels or 1-1/4 in. long for 3/4 in. thick panels, spaced 8 in. OC when panels are applied horizontally, or 8 in. OC along vertical and bottom edges and 12 in. OC in the field when panels are applied vertically. **Two layer systems:** First layer- 1 in. long for 1/2 and 5/8 in. thick panels or 1-1/4 in. long for 3/4 in. thick panels, spaced 16 in. OC. Second layer- 1-5/8 in. long for 1/2 in., 5/8 in. thick panels or 2-1/4 in. long for 3/4 in. thick panels, spaced 16 in. OC with screws offset 8 in. from first layer. **Three-layer systems:** First layer- 1 in. long for 1/2 in., 5/8 in. thick panels, spaced 24 in. OC. Second layer- 1-5/8 in. long for 1/2 in., 5/8 in. thick panels, spaced 24 in. OC. Third layer- 2-1/4 in. long for 1/2 in., 5/8 in. thick panels or 2-5/8 in. long for 5/8 in. thick panels, spaced 12 in. OC. Screws offset min 6 in. from layer below. **Four-layer systems:** First layer- 1 in. long for 1/2 in., 5/8 in. thick panels, spaced 24 in. OC. Second layer- 1-5/8 in. long for 1/2 in., 5/8 in. thick panels, spaced 24 in. OC. Third layer- 2-1/4 in. long for 1/2 in. thick panels or 2-5/8 in. long for 5/8 in. thick panels, spaced 24 in. OC. Fourth layer- 2-5/8 in. long for 1/2 in. thick panels or 3 in. long for 5/8 in. thick panels, spaced 12 in. OC. Screws offset min 6 in. from layer below.

7. **Furring Channels** — (Optional, not shown, for single or double layer systems) — Resilient furring channels fabricated from min 25 MSG corrosion-protected steel, spaced vertically a max of 24 in. OC. Flange portion attached to each intersecting stud with 1/2 in. long Type S-12 steel screws. Not for use with Item 5A and 5E.

7A. **Framing Members\*** — (Optional on one or both sides, not shown, for single or double layer systems) — As an

alternate to Item 7, furring channels and Steel Framing Members as described below:

a. **Furring Channels** — Formed of No. 25 MSG galv steel. 2-9/16 in. or 2-23/32 in. wide by 7/8 in. deep, spaced max. 24 in. OC perpendicular to studs. Channels secured to studs as described in Item b. Gypsum board attached to furring channels as described in Item 6. Not for use with Item 5A and 5E.

b. **Steel Framing Members\*** — Used to attach furring channels (Item 7Aa) to studs (Item 2). Clips spaced max. 48 in. OC. RSIC-1 and RSIC-1 (2.75) clips secured to studs with No. 8 x 1-1/2 in. minimum self-drilling, S-12 steel screw through the center grommet. RSIC-V and RSIC-V (2.75) clips secured to studs with No. 8 x 9/16 in. minimum self-drilling, S-12 steel screw through the center hole. Furring channels are friction fitted into clips. RSIC-1 and RSIC-V clips for use with 2-9/16 in. wide furring channels. RSIC-1 (2.75) and RSIC-V (2.75) clips for use with 2-23/32 in. wide furring channels.

**PAC INTERNATIONAL INC** — Types RSIC-1, RSIC-V, RSIC-1 (2.75), RSIC-V (2.75).

7B. **Framing Members\*** — (Optional, Not Shown) — As an alternate to Item 7, for single or double layer systems, furring channels and Steel Framing Members on only one side of studs as described below:

a. **Furring Channels** — Formed of No. 25 MSG galv steel, spaced 24 in. OC perpendicular to studs. Channels secured to studs as described in Item b. Batts and Blankets placed in stud cavity as described in Item 5. Two layers of gypsum board attached to furring channels as described in Item 5. Not for use with Item 5A and 5E.

b. **Steel Framing Members\*** — Used to attach furring channels (Item 7Ba) to one side of studs (Item 2) only. Clips spaced 48 in. OC., and secured to studs with two No. 8 x 2-1/2 in. coarse drywall screws, one through the hole at each end of the clip. Furring channels are friction fitted into clips.

**KINETICS NOISE CONTROL INC** — Type Isomax

7C. **Framing Members\*** — (Not Shown) — (Optional on one or both sides, not shown, for single or double layer systems) — As an alternate to Item 7, furring channels and Steel Framing Members as described below:

a. **Furring Channels** — Formed of No. 25 MSG galv steel. 2-3/8 in. wide by 7/8 in. deep, spaced max. 24 in. OC perpendicular to studs. Channels secured to studs as described in Item b. Gypsum board attached to furring channels as described in Item 6. Not for use with Item 5A and 5E.

b. **Steel Framing Members\*** — Used to attach furring channels (Item 7Aa) to studs (Item 2). Clips spaced max. 48 in. OC. GENIECLIPS secured to studs with No. 8 x 1-1/2 in. minimum self-drilling, S-12 steel screw through the center grommet. Furring channels are friction fitted into clips.

**PLITEQ INC** — Type GENIECLIP

7D. **Steel Framing Members** — (Optional, Not Shown)\* - Furring channels and resilient sound isolation clip as described below:

a. **Furring Channels** — Formed of No. 25 MSG galv steel. Spaced 24 in. OC perpendicular to studs. Channels secured to studs as described in Item b. Ends of adjoining channels overlapped 6 in. and secured together with four self-tapping No. 8x1/2 Self Drilling screws (2 per side 1 in. and 4 in. from overlap edge). Gypsum board attached to furring channels as described in Item 4. Side joint furring channels shall be attached to studs with RESILMOUNT Sound Isolation Clips - located approximately 2 in. from each end of length of channel. Both Gypsum Boards at side joints fastened into channel with screws spaced 8 in. OC, approximately 1/2 in. from joint edge. Not for use with Item 5A and 5E.

b. **Steel Framing Members\*** — Resilient sound isolation clip used to attach furring channels (Item 7Da) to studs. Clips spaced 24 in. OC., and secured to studs with No. 10 x 2-1/2 in. coarse drywall screw through the center hole. Furring channels are friction fitted into clips.

**STUDCO BUILDING SYSTEMS** — RESILMOUNT Sound Isolation Clips - Type A237 or A237R

8. **Joint Tape and Compound** — Vinyl or casein, dry or premixed joint compound applied in two coats to joints and screw heads of outer layers. Paper tape, nom 2 in. wide, embedded in first layer of compound over all joints of outer layer panels. Paper tape and joint compound may be omitted when gypsum panels are supplied with a square edge.

9. **Siding, Brick or Stucco** — (Optional, not shown) — Aluminum, vinyl or steel siding, brick veneer or stucco, meeting the requirements of local code agencies, installed over gypsum panels. Brick veneer attached to studs with corrugated metal wall ties attached to each stud with steel screws, not more than each sixth course of brick.

10. **Caulking and Sealants\*** — (Optional, not shown) — A bead of acoustical sealant applied around the partition perimeter for sound control.

**UNITED STATES GYPSUM CO** — Type AS

11. **Lead Batten Strips** — (Not Shown, For Use With Item 5B) - Lead batten strips, min 1-1/2 in. wide, max 10 ft long with a max thickness of 0.125 in. Strips placed on the interior face of studs and attached from the exterior face of the stud with two 1 in. long Type S-12 pan head steel screws, one at the top of the strip and one at the bottom of the strip. Lead batten strips to have a purity of 99.9% meeting the Federal specification QQ-L-201f, Grade "C". Lead batten strips required behind vertical joints of lead backed gypsum wallboard (Item 5B) and optional at remaining stud locations. Required behind vertical joints.

11A. **Lead Batten Strips** — (Not Shown, For Use With Item 5H) Lead batten strips, 2 in. wide, max 10 ft long with a max thickness of 0.140 in. Strips placed on the face of studs and attached to the stud with two min. 1 in. long min. Type S-8 pan head steel screws, one at the top of the strip and one at the bottom of the strip or with one min. 1 in. long min. Type S-8 pan head steel screw at the top of the strip. Lead batten strips to have a purity of 99.5% meeting the Federal specification QQ-L-201f, Grades "B, C or D". Lead batten strips required behind vertical joints of lead backed gypsum wallboard and optional at remaining stud locations.

12. **Lead Discs or Tabs** — (Not Shown, For Use With Item 5B) - Used in lieu of or in addition to the lead batten strips (Item 11) or optional at other locations - Max 3/4 in. diam by max 0.125 in. thick lead discs compression fitted or adhered over steel screw heads or max 1/2 in. by 1-1/4 in. by max 0.125 in. thick lead tabs placed on gypsum boards (Item 5B) underneath screw locations prior to the installation of the screws. Lead discs or tabs to have a purity of 99.9% meeting the Federal specification QQ-L-201f, Grade "C".

12A. **Lead Discs** — (Not Shown, for use with Item 5H) Max 5/16 in. diam by max 0.140 in. thick lead discs compression fitted or adhered over steel screw heads. Lead discs to have a purity of 99.5% meeting the Federal Specification QQ-L-201f, Grades "B, C or D".

13. **Lead Batten Strips** — (Not Shown, For Use With Item 5E) Lead batten strips, 2 in. wide, max 10 ft long with a max thickness of 0.142 in. Strips placed on the face of studs and attached to the stud with two min. 1 in. long min. Type S-8 pan head steel screws, one at the top of the strip and one at the bottom of the strip or with one min. 1 in. long min. Type S-8 pan head steel screw at the top of the strip. Lead batten strips to have a purity of 99.9% meeting the Federal specification QQ-L-201f, Grade "C". Lead batten strips required behind vertical joints of lead backed gypsum wallboard (Item 5E) and optional at remaining stud locations.

14. **Lead Tabs** — (Not Shown, For Use With Item 5E) 2 in. wide, 5 in. long with a max thickness of 0.142 in. Tabs friction-fit around front face of stud, the stud folded back flange, and the back face of the stud. Tabs required at each location where a screw (that secures the gypsum boards, Item 5E) will penetrate the steel stud. Lead tabs to have a purity of 99.9% meeting the Federal specification QQ-L-201f, Grade "C". Lead tabs may be held in place with standard adhesive tape if necessary.

**\* Indicates such products shall bear the UL or cUL Certification Mark for jurisdictions employing the UL or cUL Certification (such as Canada), respectively.**

Last Updated on 2015-02-25

[Questions?](#)

[Print this page](#)

[Terms of Use](#)

[Page Top](#)

© 2015 UL LLC

When the UL Leaf Mark is on the product, or when the word "Environment" is included in the UL Mark, please search the [UL Environment database](#) for additional information regarding this product's certification.

The appearance of a company's name or product in this database does not in itself assure that products so identified have been manufactured under UL's Follow-Up Service. Only those products bearing the UL Mark should be considered to be Certified and covered under UL's Follow-Up Service. Always look for the Mark on the product.

UL permits the reproduction of the material contained in the Online Certification Directory subject to the following conditions: 1. The Guide Information, Assemblies, Constructions, Designs, Systems, and/or Certifications (files) must be presented in their entirety and in a non-misleading manner, without any manipulation of the data (or drawings). 2. The statement "Reprinted from the Online Certifications Directory with permission from UL" must appear adjacent to the extracted material. In addition, the reprinted material must include a copyright notice in the following format: "© 2015 UL LLC".



## Design No. U465 BXUV.U465 Fire Resistance Ratings - ANSI/UL 263

[Page Bottom](#)

### Design/System/Construction/Assembly Usage Disclaimer

- Authorities Having Jurisdiction should be consulted in all cases as to the particular requirements covering the installation and use of UL Certified products, equipment, system, devices, and materials.
- Authorities Having Jurisdiction should be consulted before construction.
- Fire resistance assemblies and products are developed by the design submitter and have been investigated by UL for compliance with applicable requirements. The published information cannot always address every construction nuance encountered in the field.
- When field issues arise, it is recommended the first contact for assistance be the technical service staff provided by the product manufacturer noted for the design. Users of fire resistance assemblies are advised to consult the general Guide Information for each product category and each group of assemblies. The Guide Information includes specifics concerning alternate materials and alternate methods of construction.
- Only products which bear UL's Mark are considered Certified.

### BXUV - Fire Resistance Ratings - ANSI/UL 263

### BXUV7 - Fire Resistance Ratings - CAN/ULC-S101 Certified for Canada

[See General Information for Fire-resistance Ratings - ANSI/UL 263](#)

[See General Information for Fire Resistance Ratings - CAN/ULC-S101 Certified for Canada](#)

## Design No. U465

April 08, 2015

**Nonbearing Wall Rating — 1 HR.**

**\* Indicates such products shall bear the UL or cUL Certification Mark for jurisdictions employing the UL or cUL Certification (such as Canada), respectively.**

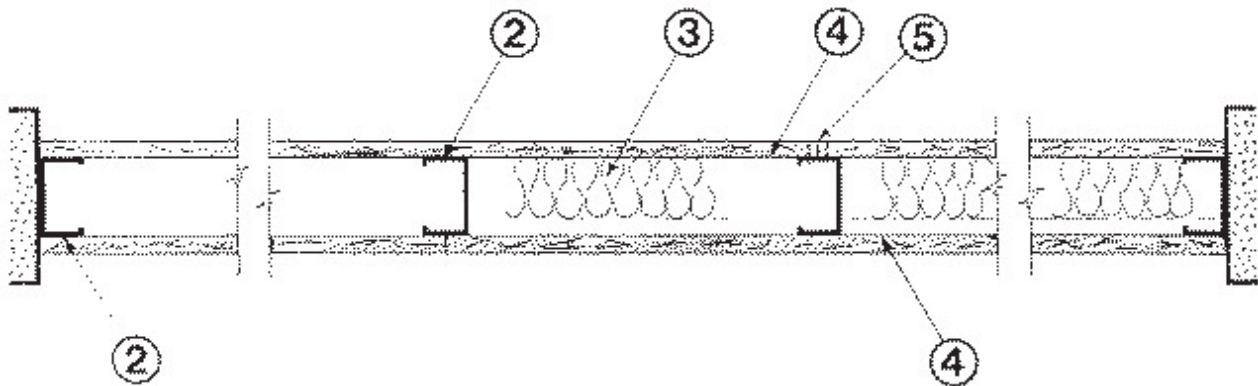

**1. Floor and Ceiling Runners** — (Not shown) — Channel shaped runners, 3-5/8 in. deep (min), 1-1/4 in. legs, formed from min No. 25 MSG galv steel, attached to floor and ceiling with fasteners spaced 24 in. OC max.

**1A. Framing Members\*— Floor and Ceiling Runners** — (Not shown) — As an alternate to Item 1 - Channel shaped, min 3-5/8 in. deep, attached to floor and ceiling with fasteners 24 in. OC. max.

**ALLSTEEL & GYPSUM PRODUCTS INC** — Type SUPREME Framing System

**CONSOLIDATED FABRICATORS CORP, BUILDING PRODUCTS DIV** — Type SUPREME Framing System

**QUAIL RUN BUILDING MATERIALS INC** — Type SUPREME Framing System



**SCAFCO STEEL STUD MANUFACTURING CO** — Type SUPREME Framing System

**STEEL CONSTRUCTION SYSTEMS INC** — Type SUPREME Framing System

**UNITED METAL PRODUCTS INC** — Type SUPREME Framing System

1B. **Framing Members\* - Floor and Ceiling Runners** — Not shown - In lieu of Item 1 — For use with Item 2B, proprietary channel shaped runners, 1-1/4 in. wide by min 3-5/8 in. deep fabricated from min 0.020 in. thick galv steel, attached to floor and ceiling with fasteners spaced 24 in. OC max.

**CALIFORNIA EXPANDED METAL PRODUCTS CO** — Viper20™ Track

**CRACO MFG INC** — SmartTrack20™

**MARINO/WARE, DIV OF WARE INDUSTRIES INC** — Viper20™ Track

**PHILLIPS MFG CO L L C** — Viper20™ Track

1C. **Floor and Ceiling Runners** — (Not shown)—For use with Item 2C- Channel shaped, fabricated from min 20 MSG corrosion-protected or galv steel, min depth to accommodate stud size, with min 1 in. long legs, attached to floor and ceiling with fasteners spaced max 24 in. OC.

1D. **Framing Members\*— Floor and Ceiling Runners** — Not shown - In lieu of Items 1 through 1C — For use with Item 2D and 4G only, proprietary channel shaped runners, 1-1/4 in. deep by min 3-5/8 in. wide fabricated from min 0.018 in. thick galv steel, attached to floor and ceiling with fasteners spaced 24 in. OC max.

**CLARKDIETRICH BUILDING SYSTEMS** — CD ProTRAK

**DMFCWBS L L C** — ProTRAK

**MBA METAL FRAMING** — ProTRAK

**RAM SALES L L C** — Ram ProTRAK

**STEEL STRUCTURAL SYSTEMS L L C** — Tri-S ProTRAK

1E. **Framing Members\*— Floor and Ceiling Runners** — Not shown - In lieu of Items 1 through 1D — For use with Item 2E and 4I only, proprietary channel shaped runners, 1-1/4 in. deep by min 3-5/8 in. wide fabricated from min 0.018 in. thick galv steel, attached to floor and ceiling with fasteners spaced 24 in. OC max.

**TELLING INDUSTRIES L L C** — TRUE-TRACK™

1F. **Framing Members\*— Floor and Ceiling Runners** — Not shown - In lieu of Items 1 through 1E — For use with Item 2, channel shaped runners, 1-1/4 in. deep by min 3-5/8 in. wide fabricated from min 25 MSG steel, attached to floor and ceiling with fasteners spaced 24 in. OC max.

**KIRII (HONG KONG) LTD** — Type KIRII

1G. **Framing Members\*— Floor and Ceiling Runners** — Not shown - In lieu of Items 1 through 1F — For use with Item 2, channel shaped runners, 1-1/4 in. deep by min 3-5/8 in. wide, attached to floor and ceiling with fasteners spaced 24 in. OC max.

**STUDCO BUILDING SYSTEMS** — CROCSTUD Track

1H. **Floor and Ceiling Runners** — (Not shown) — Channel shaped, fabricated from min 0.02 in. galv steel, min width to accommodate stud size, with min 1 in. long legs, for use with studs specified below and fabricated from min 0.02 in. galv steel or thicker, attached to floor and ceiling with fasteners spaced max 24 in. OC.

**MARINO/WARE, DIV OF WARE INDUSTRIES INC** — Viper20™ Track VT100.

1I. **Framing Members\* - Floor and Ceiling Runners** — Not shown - In lieu of Item 1 — For use with Item 2H, proprietary channel shaped runners, 1-1/4 in. wide by min 3-5/8 in. deep fabricated from min 0.020 in. thick galv steel, attached to floor and ceiling with fasteners spaced 24 in. OC max.

**TELLING INDUSTRIES L L C** — Viper20™ Track

2. **Steel Studs** — Channel shaped, 3-5/8 in. deep (min), formed from min No. 25 MSG galv steel spaced 24 in. OC max. Studs to be cut 3/4 in. less than assembly height.

2A. **Framing Members\*— Steel Studs** — As an alternate to Item 2 - Channel shaped studs, min 3-5/8 in. deep, spaced a max of 24 in. OC. Studs to be cut 3/4 in. less than assembly height.

**ALLSTEEL & GYPSUM PRODUCTS INC** — Type SUPREME Framing System

**CONSOLIDATED FABRICATORS CORP, BUILDING PRODUCTS DIV** — Type SUPREME Framing System

**QUAIL RUN BUILDING MATERIALS INC** — Type SUPREME Framing System

**SCAFCO STEEL STUD MANUFACTURING CO** — Type SUPREME Framing System

**STEEL CONSTRUCTION SYSTEMS INC** — Type SUPREME Framing System

**UNITED METAL PRODUCTS INC** — Type SUPREME Framing System

2B. **Framing Members\* - Steel Studs** — Not shown - In lieu of Item 2 — For use with Item 1B, proprietary channel shaped steel studs, 1-1/4 in. wide by min 3-5/8 in. deep fabricated from min 0.020 in. thick galv steel. Studs cut 3/4 in. less in length than assembly height.

**CALIFORNIA EXPANDED METAL PRODUCTS CO** — Viper20™

**CRACO MFG INC** — SmartStud20™

**MARINO/WARE, DIV OF WARE INDUSTRIES INC** — Viper20™

**PHILLIPS MFG CO L L C** — Viper20™

2C. **Steel Studs** — (As an alternate to Item 2, For use with Item 4E) Channel shaped, fabricated from min 20 MSG corrosion-protected or galv steel, 3-1/2 in. min depth, spaced a max of 16 in. OC. Studs friction-fit into floor and ceiling runners. Studs to be cut 5/8 to 3/4 in. less than assembly height.

2D. **Framing Members\*— Steel Studs** — As an alternate to Items 2 through 2C- For use with Item 1D and 4G only, channel shaped studs, min 3-5/8 in. wide fabricated from min 0.018 in. thick galv steel, spaced a max of 24 in. OC. Studs to be cut 1/2 in. less than assembly height.

**CLARKDIETRICH BUILDING SYSTEMS** — CD ProSTUD

**DMFCWBS L L C** — ProSTUD

**MBA METAL FRAMING** — ProSTUD

**RAM SALES L L C** — Ram ProSTUD

**STEEL STRUCTURAL SYSTEMS L L C** — Tri-S ProSTUD

2E. **Framing Members\*— Steel Studs** — As an alternate to Items 2 through 2D- For use with Item 1E and 4I only, channel shaped studs, min 3-5/8 in. wide fabricated from min 0.018 in. thick galv steel, spaced a max of 24 in. OC. Studs to be cut 1/2 in. less than assembly height.

**TELLING INDUSTRIES L L C** — TRUE-STUD™

2F. **Framing Members\*— Steel Studs** — As an alternate to Items 2 through 2E- For use with Item 1F, channel shaped studs, min 3-5/8 in. wide fabricated from min 25 MSG steel, spaced a max of 24 in. OC. Studs to be cut 1/2 in. less than assembly height.

**KIRII (HONG KONG) LTD** — Type KIRII

2G. **Framing Members\* - Steel Studs** — Not shown - In lieu of Item 2 through 2F - For use with Item 1G. Proprietary channel shaped studs, minimum 3-5/8 in. wide, Studs to be cut 1/2 in. less than the assembly height.

**STUDCO BUILDING SYSTEMS** — CROCSTUD

2H. **Framing Members\* - Steel Studs** — Not shown - In lieu of Item 2 — For use with Item 1I, proprietary channel shaped steel studs, 1-1/4 in. wide by min 3-5/8 in. deep fabricated from min 0.020 in. thick galv steel. Studs cut 3/4 in. less in length than assembly height.

**TELLING INDUSTRIES L L C** — Viper20™

2I. **Framing Members\* — Steel Studs** — In lieu of Item 2 - For use with Item 1, channel shaped studs, fabricated from min 25 MSG corrosion-protected steel, 3-5/8 in. deep (min), spaced 24 in. OC max. Studs to be cut 3/4 in. less than assembly height.

**EB MÉTAL INC** — EB Stud

2J. **Framing Members\* — Steel Studs** — In lieu of Item 2 - For use with Item 1, channel shaped studs, fabricated from min 25 MSG corrosion-protected steel, 3-5/8 in. deep (min), spaced 24 in. OC max. Studs to be cut 3/4 in. less than assembly height.

**OLMAR SUPPLY INC** — PRIMESTUD

3. **Batts and Blankets\*** — (Optional) — Mineral wool or glass fiber batts partially or completely filling stud cavity.

See **Batts and Blankets** (BZJZ) category for names of Classified companies.

3A. **Fiber, Sprayed\*** — As an alternate to Batts and Blankets (Item 3) — (100% Borate Formulation) — Spray applied cellulose material. The fiber is applied with water to completely fill the enclosed cavity in accordance with the application instructions supplied with the product with a nominal dry density of 2.7 lb/ft<sup>3</sup>. Alternate Application Method: The fiber is applied without water or adhesive at a nominal dry density of 3.5 lb/ft<sup>3</sup>, in accordance with the application instructions supplied with the product.

**U S GREENFIBER L L C** — INS735 & INS745 for use with wet or dry application. INS765LD and INS770LD are to be used for dry application only.

3B. **Fiber, Sprayed\*** — As an alternate to Batts and Blankets (Item 3) and Item 3A - Spray applied cellulose insulation material. The fiber is applied with water to interior surfaces in accordance with the application instructions supplied with the product. Applied to completely fill the enclosed cavity. Minimum dry density of 4.3 pounds per cubic ft.

**NU-WOOL CO INC** — Cellulose Insulation

3C. **Fiber, Sprayed\*** — As an alternate to Batts and Blankets (Item 3) - Spray applied cellulose fiber. The fiber is applied with water to completely fill the enclosed cavity in accordance with the application instructions supplied with the product. The minimum dry density shall be 4.30 lbs/ft<sup>3</sup>.

**INTERNATIONAL CELLULOSE CORP** — Celbar-RL

3D. **Batts and Blankets\*** — For use with Item 8. Nom 3 in. thick, minimum 3.4 pcf mineral wool batts, friction fit between the studs and floor and ceiling runners.

See **Batts and Blankets** (BZJZ) category for names of manufacturers.

4. **Gypsum Board\*** — 5/8 in. thick, 4 ft wide, attached to steel studs and floor and ceiling track with 1 in. long, Type S steel screws spaced 8 in. OC. along edges of board and 12 in. OC in the field of the board. Joints oriented vertically

and staggered on opposite sides of the assembly. When attached to item 6 (resilient channels) or 6A, 6B or 6C (furring channels), gypsum board is screw attached to furring channels with 1 in. long, Type S steel screws spaced 12 in. OC.

**ACADIA DRYWALL SUPPLIES LTD** — Type X, 5/8 Type X, Type Blueglass Exterior Sheathing

**AMERICAN GYPSUM CO** — Types AG-C, AGX-1, M-Glass

**BEIJING NEW BUILDING MATERIALS PUBLIC LTD CO** — Type DBX-1.

**CGC INC** — Types AR, C, IP-AR, IP-X1, IP-X2, IPC-AR, SCX, SHX, WRC or WRX.

**CERTAINTED GYPSUM INC** — Types 1, EGRG, GlasRoc, Type X, Type C, SilentFX, 5/8" Easi-Lite Type X.

**CONTINENTAL BUILDING PRODUCTS OPERATING CO, L L C** — Types LGFC2A, LGFC6A, LGFC-C/A, LGFC-WD, LGLLX.

**GEORGIA-PACIFIC GYPSUM L L C** — Types 5, 6, 9, C, DAP, DD, DA, DAPC, DGG, DS, GPFS6, LS, , Type X, Veneer Plaster Base - Type X, Water Rated - Type X, Sheathing - Type X, Soffit - Type X, TG-C, GreenGlass Type X, Type X ComfortGuard Sound Deadening Gypsum Board, Type LWX, Veneer Plaster Base-Type LWX, Water Rated-Type LWX, Sheathing Type-LWX, Soffit-Type LWX, Type DGLW, Water Rated-Type DGLW, Sheathing Type- DGLW, Soffit-Type DGLW, Type LW2X, Veneer Plaster Base - Type LW2X, Water Rated - Type LW2X, Sheathing - Type LW2X, Soffit - Type LW2X, Type DGL2W, Water Rated - Type DGL2W, Sheathing - Type DGL2W.

**NATIONAL GYPSUM CO** — Types eXP-C, FSK, FSK-C, FSK-G, FSMR-C, FSW-C, FSW-G, FSW, FSW-3, FSW-5, FSW-6, FSW-8, FSL.

**PABCO BUILDING PRODUCTS L L C, DBA PABCO GYPSUM** — Types PG-C, PG-9, PG-11, PGS-WRS.

**PANEL REY S A** — Types GREX, PRX, RHX, MDX, ETX.

**SIAM GYPSUM INDUSTRY (SARABURI) CO LTD** — Type EX-1

**THAI GYPSUM PRODUCTS PCL** — Type X, Type C.

**UNITED STATES GYPSUM CO** — Type AR, C, FRX-G, IP-AR, IP-X1, IP-X2, IPC-AR, SCX, SHX, WRC, WRX, USGX (Joint tape and compound, Item 5, optional for use with Type USGX).

**USG MEXICO S A DE C V** — Type AR, C, IP-AR, IP-X1, IP-X2, IPC-AR, SCX, SHX, WRC or WRX.

4A. **Gypsum Board\*** — (As alternate to Item 4) - Nom 5/8 in. thick gypsum panels with beveled, square or tapered edges, applied vertically or horizontally. Vertical joints centered over studs and staggered one stud cavity on opposite sides of studs. Horizontal edge joints and horizontal butt joints on opposite sides of studs need not be staggered or backed by steel framing. Panels attached to steel studs and floor runner with 1 in. long Type S steel screws spaced 8 in. OC when applied horizontally, or 8 in. OC along vertical and bottom edges and 12 in. OC in the field when panels are applied vertically. When used in widths other than 48 in., gypsum panels to be installed horizontally.

**CERTAINTED GYPSUM INC** — Type X, Type C, Type EGRG/ GlasRoc.

**CGC INC** — Types AR, C, IP-AR, IP-X1, IP-X2, IPC-AR, SCX, SHX, WRC or WRX.

**CONTINENTAL BUILDING PRODUCTS OPERATING CO, L L C** — Type LGFC6A, LGFC-C/A

**GEORGIA-PACIFIC GYPSUM L L C** — Types DAP, DAPC, DGG, DS.

**THAI GYPSUM PRODUCTS PCL** — Type X, Type C.

**UNITED STATES GYPSUM CO** — Type AR, C, FRX-G, IP-AR, IP-X1, IP-X2, IPC-AR, SCX, SHX, WRC, WRX, , USGX (Joint tape and compound, Item 5, optional for use with Type USGX).

**USG MEXICO S A DE C V** — Type AR, C, IP-AR, IP-X1, IP-X2, IPC-AR, SCX, SHX, WRC or WRX.

4B. **Gypsum Board\*** — (As an alternate to Items 4 or 4A) — Nom 3/4 in. thick, 4 ft wide, installed as described in Item 4A with screw length increased to 1-1/4 in.

**CGC INC** — Types AR, IP-AR.

**UNITED STATES GYPSUM CO** — Types AR, IP-AR.

**USG MEXICO S A DE C V** — Types AR, IP-AR.

4C. **Gypsum Board\*** — As an alternate to Items 4, 4A, and 4B - Nom. 5/8 in. thick gypsum panels, with square edges, applied horizontally. Gypsum panels fastened to framing with 1 in. long bugle head steel screws spaced a max 8 in. OC, with last 2 screws 3/4 in. and 4 in. from each edge of board. Horizontal joints need not be backed by steel framing. Horizontal edge joints and horizontal butt joints on opposite sides of studs on interior walls need not be staggered or backed by steel framing.

**GEORGIA-PACIFIC GYPSUM L L C** — GreenGlass Type X.

4D. **Gypsum Board\*** — As an alternate to Items 4, 4A, 4B, and 4C - Nom. 5/8 in. thick gypsum panels applied vertically or horizontally. Horizontal edge joints and horizontal butt joints on opposite sides of studs need not be staggered or backed by steel framing. Gypsum panels fastened to framing with 1 in. long Type S steel screws 8 in. OC along vertical edges and 12 in. OC in the field when panels are applied vertically, or 1-1/2 in. from board edges, 3 in. from board edge and every 8 in. OC in the field when applied horizontally. Screws spaced a max 12 in. along the top and bottom edges of the wall.

**NATIONAL GYPSUM CO** — Types eXP-C, FSK, FSK-C, FSK-G, FSL, FSW-C, FSW-G, FSW, FSW-3, FSW-5, FSW-6, FSW-8, FSMR-C.

4E. **Gypsum Board\*** — (As an alternate to Items 4 through 4D) - Installed as described in Item 4. 5/8 in. thick, 4 ft. wide, paper surfaced, applied vertically only and fastened to the studs and plates with 1 in. long, Type S steel screws spaced, 8 in. OC. Not to be used with item 6.

**NATIONAL GYPSUM CO** — SoundBreak XP Type X Gypsum Board

4F. **Gypsum Board\*** — (Not Shown) - (As an alternate to Item 4 when used as the base layer on one or both sides of wall. For direct attachment only to steel studs Item 2C) - Nom 5/8 in. thick lead backed gypsum panels with beveled, square or tapered edges, applied vertically. Vertical joints centered over studs and staggered min 1 stud cavity on opposite sides of studs. Gypsum board secured to studs with 1-1/4 in. long Type S-12 steel screws spaced 8 in. OC at perimeter and 12 in. OC in the field.

**RAY-BAR ENGINEERING CORP** — Type RB-LBG

4G. **Gypsum Board\*** — (As an alternate to Items 4 through 4F) — For use with Items 1D and 2D only, 5/8 in. thick, 4 ft wide, attached to steel studs and floor and ceiling track with 1 in. long, Type S steel screws spaced 8 in. OC. along edges of board and 12 in. OC in the field of the board. Joints oriented vertically and staggered on opposite sides of the assembly.

**CONTINENTAL BUILDING PRODUCTS OPERATING CO, L L C** — Type LGFC6A, LGFC-C/A

**NATIONAL GYPSUM CO** — Types FSW

**UNITED STATES GYPSUM CO** — Type SCX

4H. **Gypsum Board\*** — (As an alternate to Items 4 through 4G) — Nominal 5/8 in. thick, 4 ft wide panels, applied

vertically and secured as described in Item 4.

**PABCO BUILDING PRODUCTS L L C, DBA PABCO GYPSUM** — Type QuietRock ES.

4I. **Gypsum Board\*** — (As an alternate to Items 4 through 4F) — For use with Items 1E and 2E only, 5/8 in. thick, 4 ft wide, attached to steel studs and floor and ceiling track with 1 in. long, Type S steel screws spaced 8 in. OC. along edges of board and 12 in. OC in the field of the board. Joints oriented vertically and staggered on opposite sides of the assembly.

**UNITED STATES GYPSUM CO** — Type SCX

4J. **Gypsum Board\*** — (Not Shown) - (As an alternate to Item 4 when used as the base layer on one or both sides of wall. For direct attachment only to steel studs Item 2C) - Nom 5/8 in. thick lead backed gypsum panels with beveled, square or tapered edges, applied vertically. Vertical joints centered over studs and staggered min 1 stud cavity on opposite sides of studs. Gypsum board secured to studs with 1-1/4 in. long Type S-12 steel screws spaced 8 in. OC at perimeter and 12 in. OC in the field. To be used with Lead Batten Strips (see Item 9A) or Lead Discs (see Item 10A).

**MAYCO INDUSTRIES INC** — Type X-Ray Shielded Gypsum

4K. **Gypsum Board\*** — (As an alternate to Item 4 and 4A, not for use with Items 1D, 1E, 2D and 2E) - Nom. 5/8 in. thick gypsum panels with beveled, square or tapered edges installed as described in Item 4 and 4A.

**CGC INC** — Type ULX

**UNITED STATES GYPSUM CO** — Type ULX

**USG MEXICO S A DE C V** — Type ULX

4L. **Gypsum Board\*** — (Not Shown) - (As an alternate to Item 4 when used as the base layer on one or both sides of wall. For direct attachment only to steel studs Item 2C). Nom 5/8 in. thick lead backed gypsum panels with beveled, square or tapered edges, applied vertically. Vertical joints centered over studs and staggered min 1 stud cavity on opposite sides of studs. Wallboard secured to studs with 1-1/4 in. long Type S-12 steel screws gypsum panel steel screws spaced 8 in. OC at perimeter and 12 in. OC in the field. Lead batten strips required behind vertical joints of lead backed gypsum wallboard and optional at remaining stud locations. Lead batten strips, min 2 in. wide, max 8 ft long with a max thickness of 0.14 in. placed on the face of studs and attached to the stud with construction adhesive and two 1 in. long Type S-12 pan head steel screws, one at the top of the strip and one at the bottom of the strip. Lead discs, nominal 3/8 in. diam by max 0.085 in. thick. Compression fitted or adhered over the screw heads. Lead batten strips and discs to have a purity of 99.9% meeting the Federal specification QQ-L-201f, Grade "C".

**RADIATION PROTECTION PRODUCTS INC** — Type RPP - Lead Lined Drywall

4M. **Gypsum Board\*** — (For use with Item 8) - 5/8 in. thick, 4 ft wide, applied vertically over Mineral and Fiber Board (Item 8) with vertical joints located anywhere over stud cavities. Secured to mineral and fiber boards with 1-1/2 in. Type G Screws spaced 8 in. OC along edges of each vertical joint and 12 in. OC in intermediate field of the Mineral and Fiber Board (Item 8). Secured to outermost studs and floor and ceiling runners with 2 in. long Type S screws spaced 8 in. OC. Gypsum Board joints covered with paper tape and joint compound. Screw heads covered with joint compound.

**AMERICAN GYPSUM CO** — Type AG-C

**CERTAINTED GYPSUM INC** — Type FRPC, Type C

**CGC INC** — Types C, IP-X2, IPC-AR

**CONTINENTAL BUILDING PRODUCTS OPERATING CO, L L C** — Type LGFC-C/A

**GEORGIA-PACIFIC GYPSUM L L C** — Types 5, DAPC, TG-C

**NATIONAL GYPSUM CO** — Types eXP-C, FSK-C, FSW-C

**PABCO BUILDING PRODUCTS L L C, DBA PABCO GYPSUM** — Type PG-C.

**PANEL REY S A** — Type PRC

**THAI GYPSUM PRODUCTS PCL** — Type C

**UNITED STATES GYPSUM CO** — Types C, IP-X2, IPC-AR

**USG MEXICO S A DE C V** — Types C, IP-X2, IPC-AR

**4N. Wall and Partition Facings and Accessories\*** — (As an alternate to Item 4) — Nominal 5/8 in. thick, 4 ft wide panels, applied vertically and secured as described in Item 4.

**PABCO BUILDING PRODUCTS L L C, DBA PABCO GYPSUM** — Type QuietRock 527.

**4O. Gypsum Board\*** — As an alternate to Items 4, 4A, 4B, and 4C - Two layers Nom. 5/16 in. thick gypsum panels applied vertically or horizontally. Horizontal edge joints and horizontal butt joints on opposite sides of studs need not be staggered or backed by steel framing. Horizontal joints on the same side need not be staggered. When applied horizontally, both layers of gypsum board fastened to each side of framing with 1 in. long Type S steel screws spaced 8 in. OC and staggered 4 in. OC between layers. When applied vertically, both layers of gypsum board fastened to each side of framing with 1 in. long Type S steel screws spaced 8 in. OC along vertical edges and 12 in. OC in the field, staggered 4 in. OC between layers. Screws spaced a max 12 in. along the top and bottom edges of the wall.

**NATIONAL GYPSUM CO** — Type FSW.

**5. Joint Tape and Compound** — Vinyl, dry or premixed joint compound, applied in two coats to joints and screw heads; paper tape, 2 in. wide, embedded in first layer of compound over all joints. As an alternate, nominal 3/32 in. thick gypsum veneer plaster may be applied to the entire surface of Classified veneer baseboard. Joints reinforced. Paper tape and joint compound may be omitted when gypsum boards are supplied with square edges.

**6. Resilient Channel** — (Optional-Not Shown) — 25 MSG galv steel resilient channels spaced vertically max 24 in. OC, flange portion attached to each intersecting stud with 1/2 in. long type S-12 pan head steel screws. May not be used with Item 4F or 4J.

**6A. Steel Framing Members (Not Shown)\*** — As an alternate to Item 6, furring channels and resilient sound isolation clip as described below:

a. **Furring Channels** — Formed of No. 25 MSG galv steel. 2-9/16 in. or 2-23/32 in. wide by 7/8 in. deep, spaced 24 in. OC perpendicular to studs. Channels secured to studs as described in Item b. Ends of adjoining channels are overlapped 6 in. and tied together with double strand of No. 18 SWG galv steel wire near each end of overlap. As an alternate, ends of adjoining channels may be overlapped 6 in. and secured together with two self-tapping No. 6 framing screws, min 7/16 in. long at the midpoint of the overlap, with one screw on each flange of the channel.

b. **Framing Members\*** — Used to attach furring channels (Item a) to studs (Item 2). Clips spaced 48 in. OC., and secured to studs with 1-5/8 in. wafer or hex head Type S steel screw through the center grommet. Furring channels are friction fitted into clips. RSIC-1 clip for use with 2-9/16 in. wide furring channels. RSIC-1 (2.75) clip for use with 2-23/32 in. wide furring channels.

**PAC INTERNATIONAL INC** — Types RSIC-1, RSIC-1 (2.75).

**6B. Framing Members\*** — (Not Shown) — (Optional on one or both sides) — As an alternate to Item 6, furring channel and Steel Framing Members as described below:

a. **Furring Channels** — Formed of No. 25 MSG galv steel. 2-3/8 in. wide by 7/8 in. deep, spaced max. 24 in. OC perpendicular to studs. Channels secured to studs as described in Item b. Gypsum board attached to furring channels as described in Item 4.

b. **Steel Framing Members\*** — Used to attach furring channels (Item 6Ba) to studs (Item 2). Clips spaced max. 48 in. OC. GENIECLIPS secured to studs with No. 8 x 1-1/2 in. minimum self-drilling, S-12 steel screw through the center grommet. Furring channels are friction fitted into clips.

**PLITEQ INC** — Type Genie Clip

**6C. Steel Framing Members** — (Optional, Not Shown)\* - Furring channels and resilient sound isolation clip as described below:

a. **Furring Channels** — Formed of No. 25 MSG galv steel. Spaced 24 in. OC perpendicular to studs. Channels secured to studs as described in Item b. Ends of adjoining channels overlapped 6

in. and secured together with four self-tapping No. 8x1/2 Self Drilling screws (2 per side 1 in. and 4 in. from overlap edge). Gypsum board attached to furring channels as described in Item 4. Side joint furring channels shall be attached to studs with RESILMOUNT Sound Isolation Clips - Type A237R located approximately 2 in. from each end of length of channel. Both Gypsum Boards at side joints fastened into channel with screws spaced 8 in. OC, approximately 1/2 in. from joint edge.

b. **Steel Framing Members\*** — Resilient sound isolation clip used to attach furring channels (Item 6Ca) to studs. Clips spaced 24 in. OC., and secured to studs with No. 10 x 2-1/2 in. coarse drywall screw through the center hole. Furring channels are friction fitted into clips.

**STUDCO BUILDING SYSTEMS** — RESILMOUNT Sound Isolation Clips - Type A237R

**7. Wall and Partition Facings and Accessories\*** — (Optional, Not shown) — Nominal 1/2 in. thick, 4 ft wide panels, for optional use as an additional layer on one or both sides of the assembly. Panels attached in accordance with manufacturer's recommendations. When the QR-510 panel is installed between the steel framing and the UL Classified gypsum board, the required UL Classified gypsum board layer(s) is/are to be installed as indicated as to fastener type and spacing, except that the required fastener length shall be increased by a minimum of 1/2 in. Not evaluated or intended as a substitute for the required layer(s) of UL Classified Gypsum Board.

**PABCO BUILDING PRODUCTS L L C, DBA PABCO GYPSUM** — Type QuietRock QR-510.

**8. Mineral and Fiber Board\*** — (Optional, Not shown) — For optional use as an additional layer on one side of wall. Nom 1/2 in. thick, 4 ft wide with long dimension parallel and centered over studs. Attached to studs and floor and ceiling runners with 1-5/8 in. long Type S steel screws, spaced 12 in. OC and 24 in. OC along all intermediate framing. The required UL Classified gypsum board layer (Item 4M) is to be installed over the Mineral and Fiber Boards. Batts and Blankets, Item 3D, and Adhesive, Item 11, are required.

**HOMASOTE CO** — Homasote Type 440-32

**9. Lead Batten Strips** — (Not Shown, For Use With Item 4E) - Lead batten strips, min 1-1/2 in. wide, max 10 ft long with a max thickness of 0.125 in. Strips placed on the interior face of studs and attached from the exterior face of the stud with two 1 in. long Type S-12 pan head steel screws, one at the top of the strip and one at the bottom of the strip. Lead batten strips to have a purity of 99.9% meeting the Federal specification QQ-L-201f, Grade "C". Lead batten strips required behind vertical joints of lead backed gypsum board (Item 4E) and optional at remaining stud locations. Required behind vertical joints.

**9A. Lead Batten Strips** — (Not Shown, for use with Item 4J) Lead batten strips, 2 in. wide, max 10 ft long with a max thickness of 0.140 in. Strips placed on the face of studs and attached to the stud with two min. 1 in. long min. Type S-8 pan head steel screws, one at the top of the strip and one at the bottom of the strip or with one min. 1 in. long min. Type S-8 pan head steel screw at the top of the strip. Lead batten strips to have a purity of 99.5% meeting the Federal specification QQ-L-201f, Grades "B, C or D". Lead batten strips required behind vertical joints of lead backed gypsum wallboard (Item 4J) and optional at remaining stud locations.

**10. Lead Discs or Tabs** — (Not Shown, For Use With Item 4E) - Used in lieu of or in addition to the lead batten strips (Item 8) or optional at other locations - Max 3/4 in. diam by max 0.125 in. thick lead discs compression fitted or adhered over steel screw heads or max 1/2 in. by 1-1/4 in. by max 0.125 in. thick lead tabs placed on gypsum boards (Item 4E) underneath screw locations prior to the installation of the screws. Lead discs or tabs to have a purity of 99.9% meeting the Federal specification QQ-L-201f, Grade "C".

**10A. Lead Discs** — (Not Shown, for use with Item 4J) Max 5/16 in. diam by max 0.140 in. thick lead discs compression fitted or adhered over steel screw heads. Lead discs to have a purity of 99.5% meeting the Federal Specification QQ-L-201f, Grades "B, C or D".

**11. Adhesive** — Not Shown - (For use with Item 8) - Construction grade adhesive applied in vertical, serpentine, nominal 3/8 in. wide beads down the length of both vertical edges of Mineral and Fiber Board (Item 8).

**12. Wall and Partition Facings and Accessories\*** — (Optional, Not Shown) — For use with Items 1 to 1I, Items 2 to 2J, Item 3, Items 4 to 4I, Item 5 and Item 6. For maximum fire rating of 1 hour. On one side of the wall, over the first layer of Gypsum Board (Item 4 to Item 4I), install RefleXor membrane with the gold side facing outwards. Membrane installed with T50 staples spaced 12 inches on center in both directions as per manufacturer's instructions, seams in membrane to be overlapped by 2 inches. When RefleXor membrane is used an additional layer of Gypsum Board that is identical to the one used in the first layer and as specified in Item 4 to Item 4I shall be installed over the membrane. The additional layer of Gypsum Board to be installed through the membrane to the stud as specified in Item 4 to Item 4I except the fastener length shall be increased by a minimum of 5/8 inch. Install Batts and Blankets in the stud cavity as per Item 3. On the other side of the wall, prior to the installation of the Gypsum Board, install Resilient Channels as per Item 6. Over the Resilient Channels install 3/4 inch thick SONOpan panel secured to the Resilient Channels with drywall screws and washers spaced at 16 in. OC on the perimeter of the panel and 8 in. OC in the field of the panel. Over the SONOpan panel install the same Gypsum Board as specified in Item 4 to Item 4I with the fastener length increased by minimum 3/4 inch. Not evaluated or intended as a substitute for the required layer(s) of UL Classified Gypsum Board.

**MSL** — RefleXor membrane, SONOpan panel.

**\* Indicates such products shall bear the UL or cUL Certification Mark for jurisdictions employing the UL or cUL Certification (such as Canada), respectively.**



[Last Updated](#) on 2015-04-08

---

[Questions?](#)

[Print this page](#)

[Terms of Use](#)

[Page Top](#)

© 2015 UL LLC

When the UL Leaf Mark is on the product, or when the word "Environment" is included in the UL Mark, please search the [UL Environment database](#) for additional information regarding this product's certification.

The appearance of a company's name or product in this database does not in itself assure that products so identified have been manufactured under UL's Follow-Up Service. Only those products bearing the UL Mark should be considered to be Certified and covered under UL's Follow-Up Service. Always look for the Mark on the product.

UL permits the reproduction of the material contained in the Online Certification Directory subject to the following conditions: 1. The Guide Information, Assemblies, Constructions, Designs, Systems, and/or Certifications (files) must be presented in their entirety and in a non-misleading manner, without any manipulation of the data (or drawings). 2. The statement "Reprinted from the Online Certifications Directory with permission from UL" must appear adjacent to the extracted material. In addition, the reprinted material must include a copyright notice in the following format: "© 2015 UL LLC".

**SECTION 092220 – ACOUSTICAL INSULATION**

## PART 1 - GENERAL

## 1.1 SUMMARY

- A. Provide materials, fabrications and installation of acoustical insulation and associated accessories.

## 1.2 SUBMITTALS

- A. Comply with requirements of Section 013300 – Submittal Procedures.
- B. Manufacturer's product data and literature describing each type of insulation.

## 1.3 QUALITY ASSURANCE

- A. Regulatory Requirements:
  - 1. Insulation shall be certified by the manufacturer to comply with California standards for insulating materials.
  - 2. Insulating materials shall be installed in compliance with Flame Spread Rating and Smoke Density requirements of IBC.
- B. Fire Performance Characteristics: Provide insulation materials whose fire performance characteristics have been determined per the ASTM test method indicated below. Identify products with appropriate markings of applicable testing and inspecting organization.
  - 1. Surface Burning Characteristic: ASTM E84
  - 2. Fire Resistance Ratings: ASTM E119
  - 3. Combustion Characteristics: ASTM E136
- C. Single Source Responsibility for Insulation Products: Obtain each type of building insulation from a single source with resources to provide products of consistent quality in appearance and physical properties without delaying progress of the Work.

## 1.5 DELIVERY, STORAGE, AND HANDLING

- A. Comply with requirements of Section 016000 – Product Requirements.
- B. Deliver and store packaged materials in original containers bearing identification of manufacturer's name, thermal resistance rating, and fiber materials. Maintain seals unbroken and labels intact until time of use.
- C. Keep materials dry by storing off ground under watertight covers.

## 1.6 PROJECT CONDITIONS

- A. Comply with requirements of Section 013100 – Project Management and Coordination.
- B. Do not install insulation until construction has progressed to a point that inclement weather will not damage or wet insulation.

## PART 2 - PRODUCTS

### 2.1 MATERIALS

- A. Acoustical Insulation: Unfaced, friction-fit, flexible sound attenuation batt of fiberglass.
  - 1. Provide thermal resistance rating of R-13 for 3-5/8" and 4" stud wall and R-19 for 6" stud walls, unless otherwise shown.
  - 2. Comply with requirements of ASTM C 665-84, Type I.
  - 3. Manufacturers: Owens-Corning Fiberglass Corp. "Unfaced Fiberglass Insulation," Schuller- "Unfaced Fiberglass Insulation" or Certainteed Products Corp. "Rigid Fit Unfaced Fiberglass Insulation."

### 2.2 ACCESSORIES

- A. Electrical Box Acoustical Sealer: Resilient sealer pads; "Electrical Box Pads" manufactured by 3M, or approved equivalent.
- B. Insulation Support: String wire, staples, nails as required.
- C. Stick Fasteners: Rust-resistant metal fasteners and washers adhesively applied to substrate. Stic-Klip Mfg. Co. "Type A or N" with Speed Washers or Miracle Adhesives Corp. "Stuk-Ups, Prong or Spindle and Washer".
- D. Adhesive for Stick Fasteners: Type as recommended by fastener manufacturer.
- E. Sealing Tape: Type as recommended by the thermal insulation manufacturer.

## PART 3 - EXECUTION

### 3.1 EXAMINATION

- A. Examine areas to receive insulation for conditions that will adversely affect installation and performance.
- B. Do not start work until defects have been corrected.
- C. Coordination: Ensure that all work that will be concealed by the work of this Section, such as electrical and plumbing work, that require inspection, have received all required inspections and been accepted by the inspecting authority.

### 3.2 INSTALLATION OF INSULATION

- A. General Requirements:

1. Comply with insulation manufacturer's instructions applicable to products and application indicated. If printed instructions are not available or do not apply to project conditions, consult manufacturer's technical representative for specific recommendations before proceeding with installation of insulation.
  2. Install insulation to fit snugly between framing members and around pipes, conduits, and outlet boxes as necessary to maintain integrity of insulation.
  3. Provide means to prevent displacement where required.
- B. Acoustical Insulation:
1. Fill spaces between studs with acoustical insulation.
  2. Cover rear surface of all recessed mechanical and electrical outlet boxes with outlet box acoustical isolation pad.

### 3.3 DEFECTIVE WORK

- A. Remove any wet insulation or material deemed defective by the Architect, and replace with new material.
- B. Restore other work to original condition which was damaged by repair or replacement of defective insulation work.
- C. Remove damaged materials from project.

### 3.4 PROTECTION

- A. General: Protect installed insulation and vapor retarders from damage due to harmful weather exposures, physical abuse, and other causes.
- B. Provide temporary coverings or enclosures where insulation will be subject to abuse and cannot be concealed and protected by permanent construction immediately after installation.

END OF SECTION

**SECTION 092900 – GYPSUM BOARD**

## PART 1 - GENERAL

## 1.1 SUMMARY

A. Work Included: Provide and Install gypsum board panels and cementitious panels, complete as shown, including finishing materials and accessories.

1. Interior gypsum board walls, ceilings and soffits:

a. Fire/smoke-rated assemblies.

b. Acoustic assemblies.

c. Water-resistant assemblies.

d. Impact-resistant gypsum board wall assemblies.

e. General wall assemblies, including multi-layer assemblies to facilitate reveals and other decorative features.

f. Cementitious backer board for interior tile assemblies.

2. Interior finishing materials and accessories:

a. Tapes, joint treatments, and coating materials to prepare wall surfaces for painting by others.

b. Corner beads, reveals, and other trims.

c. Neoprene tapes for sealing to work by others.

d. Fasteners, adhesives and sealants.

e. Special trim and accessories.

3. Projectile Resistant Backing: ballistic-proof fiberglass backing for Pharmacy wall assemblies and where shown on Drawings.

B. Work Specified Elsewhere:

1. Section 092216 – Non-Structural Metal Framing.

4. Section 093000 – Tile.

5. Section 072400 – Exterior Insulation and Finish System (EIFS).

6. Section 099123 – Interior Painting.

## 1.2 SUBMITTALS

A. Comply with requirements of Section 013300 – Submittal Procedures.

B. Provide manufacturers' data describing products and installations.

## 1.3 QUALITY ASSURANCE

- A. Comply with the latest edition of the following standards:
  - 1. American Society for Testing and Materials ASTM C 840, Standard Specification for Application and Finishing of Gypsum Board.
  - 2. Gypsum Association (GA) File Numbers in GA-600 Fire Resistance Design Manual.
- B. Fire rated gypsum board systems shall satisfy minimum fire ratings as noted and shall conform to methods approved by applicable Building Code.
- C. Tolerances of Installed Trims and Accessories:
  - 1. Horizontal Variation from Level: 1/8-inch in 12 feet.
  - 2. Vertical Variation from Plumb: 1/8-inch in 8 feet.

## 1.5 DELIVERY, STORAGE AND HANDLING

- A. Comply with requirements of Section 016000 – Product Requirements.
- B. Deliver materials to the project site with manufacturers' labels intact and legible.
- C. Keep materials dry by storing inside building and fully protect from weather.
- D. Stack gypsum board neatly and flat, with care to avoid damage to edges, ends and surfaces.

## 1.6 PROJECT CONDITIONS

- A. Environmental Requirements: Establish and maintain application and finishing environment in accordance with ASTM C 840.
- B. Provide adequate ventilation to eliminate excessive moisture within building during this work.

## PART 2 - PRODUCTS

## 2.1 MATERIALS - INTERIOR APPLICATIONS

- A. Interior Gypsum Board: Use 5/8-inch-thick, Type 'X' gypsum board throughout, unless otherwise noted.
  - 1. Typical Finish Board, use throughout unless otherwise noted. ASTM C 36, Type X; tapered, or beveled taper edge, 48 inches wide by maximum length to minimize number of joints.
  - 2. Water-Resistant Gypsum Backing Board: Provide USG's Fiberock Brand "Aqua-Tough"; Georgia-Pacific (GP) "DensShield Tile Guard"; Glass-Mat, Water-Resistant Backing Board through core gypsum board panels per ASTM C 1178, Type FRX-G; tapered, or beveled taper edge, 48 inches wide by maximum length to minimize number of joints.

- a. Locations: Use at high humidity/moisture locations, including HSKP rooms, Kitchen and Servery areas.
3. High Abuse, Impact Resistant Board: Provide National Gypsum Hi-Abuse Kal-Kore, USG's Fiberock Brand "Aqua-Tough". 5/8-inch-thick, ASTM C1278, Type X; fiber reinforced gypsum panels; tapered, or beveled taper edge, 48 inches wide by maximum length to minimize number of joints.
    - a. Gypsum core wall panel with additives to enhance surface indentation resistance, and impact resistance of the core and surface with abrasion-resistant paper on front and long edges with heavy liner paper bonded to the back side and conforming to ASTM C36.
    - b. Impact Resistance: No failure after 100 impacts when tested in accordance with ASTM E695, modified.
    - c. Indentation Resistance: Not less than the following loads to produce the indicated depth of the surface indentation when tested in accordance with ASTM D1037, modified:
      - 1) 0.100-inch at 260 pounds.
      - 2) 0.200-inch at 524 pounds.
    - d. Locations: Typical all corridors from finished floor to 48 inches above finished floor.
  4. 1/4-inch Flexible Type: Provide board manufactured to bend to fit tighter radii than specified regular-type gypsum board.
    - a. Provide only at non-rated curved layouts that exceed maximum allowable bending radii of specified standard thickness gypsum board.
    - b. Thickness: 1/4 inch. Provide minimum 2 layer application with staggered joints.
    - c. Long Edges: Tapered.
  5. Early-install/Concealed locations (Contractor Option): Provide Georgia Pacific DensGlass Ultra Shaft and DensAmor Plus in conformance with ASTM D 3273; products inherently mold and mildew resistant for use in shaftwalls, concealed locations above finished ceilings, internal layers of multi-layer assemblies and other locations approved by Architect to allow installation before the building enclosure is 100-percent complete.
    - a. Use at Shaft-side of shaft assemblies and any location where early install is required prior to closing in of the building.
- B. Cementitious Backer Board: Per ANSI A108.1; Provide Custom Building Product's "Wonderboard"; USG's "Durock Cement Board". Panels of high-density portland cement surface coating on both faces of lightweight portland cement and

expanded ceramic aggregate core, nominal 5/8-inch-thick and 3.2 to 3.8 pounds per square foot.

1. General: Provide as shown on Drawings for tile assemblies specified in Section 093000 – Tile. (Typical at all toilets/restrooms) At fire-rated wall assemblies and inside faces of exterior walls, apply over gypsum board base layer.

C Acoustically enhanced Gypsum Wallboard Composite:

- a. Two-ply high density, mold resistant, paper faced gypsum wallboard laminated together with viscoelastic dampening polymer.
- b. Composite Thickness 5/8 inches
- c. Fire-resistance, Type X gypsum core
- d. Base Product: Quite Rock ES by PABCO Gypsum OR Sound Break XP by National Gypsum Company

D. Interior Joint Finishing Materials:

1. General: Comply with ASTM C 475/C 475M.
2. Joint Tape:
  - a. Interior Gypsum Wallboard: Paper.
  - b. Tile Backing Panels: As recommended by panel manufacturer.
3. Joint Compound for Interior Gypsum Wallboard: For each coat use formulation that is compatible with other compounds applied on previous or for successive coats.
  - a. Prefilling: At open joints, beveled panel edges, and damaged surface areas, use setting-type taping compound.
  - b. Embedding and First Coat: For embedding tape and first coat on joints, fasteners, and trim flanges, use setting-type taping or drying-type, all-purpose compound as recommended by the manufacturer to obtain best results from actual project conditions.
    - 1) Use setting-type compound for installing paper-faced metal trim accessories.
  - c. Fill Coat: For second coat, use drying-type, all-purpose compound.
  - d. Finish Coat: For third coat, use drying-type, all-purpose compound.
  - e. Skim Coat: For final coat of Level 5 finish, use drying-type, all-purpose compound.
4. Joint Compound for Tile Backing Panels:



- a. Water-Resistant Gypsum Backing Board: Use setting-type taping compound and setting-type, sandable topping compound.
  - b. Glass-Mat, Water-Resistant Backing Panel: As recommended by backing panel manufacturer.
  - c. Cementitious Backer Units: As recommended by backer unit manufacturer.
- E. Fasteners:
1. Screws: ASTM C 954 or ASTM C 1002 self-drilling and self-tapping steel screws with double-lead thread design as approved by system manufacturer for standard and heavier gauge load bearing steel framing.
  2. Nails: ASTM C 514, annular ring type as approved by system manufacturer.
  3. Staples: Galvanized, as recommended to approved accessory manufacturer.
- F. Metal Backing: Refer to Section 092216 – Non-Structural Metal Framing.
- G. Metal Accessories: ASTM C 1047 Electro-galvanized steel corner beads and trim (casing beads) formed for application of joint cement and manufactured specifically for gypsum board construction, minimum base steel 0.014 inch thick.
- H. Special Trims and Accessories:
1. General: Provide extruded aluminum trims and accessories in conforming to profiles and shapes as shown on Drawings and as specified.
    - a. Provide double-layer gypsum board assemblies at locations shown on Drawings to receive recessed reveal trims.
    - b. Material: Extruded aluminum alloy 6063 T5.
    - c. Manufacturer: Provide products manufactured by Gordon, Fry Reglet Company, Flannery Company, or equal.
      - a. Accessories: For each trim profile noted below, provide factory fabricated where required by layouts shown on Drawings, including:
        - 1) Mitered assemblies for "T-intersections" and "X-intersections".
        - 2) Finished end caps.
  2. Partition "End Cap" Trims: Provide for providing finished ends to gypsum board walls including chemical conversion coating. Typical where gypsum board walls butt mullions of window or window wall assemblies, allowing attachment of partition cap to mullion prior to construction of

gypsum board wall.

- a. Overall Width: Provide width matched to partition assembly, including:
    - 1) 4-inch stud walls with 5/8-inch gypsum board each side.
    - 2) 6-inch stud walls with 5/8-inch gypsum board each side.
  - b. Tape/screw Flanges: Nominal 7/8-inch.
  - c. Manufacturer: Provide "910 Series" Final Forms by Gordon or equivalent products manufactured by Fry Reglet Company, Flannery Company, or equal.
3. Reveal "Top Track" Trim: Provide for top of wall or partial height partition top cap termination where shown on Drawings.
- a. Reveal Depth: Nominal 5/8-inch for use with 5/8-inch gypsum board panels.
  - b. Reveal Width: As shown on Drawings.
  - c. Overall Width: Provide width matched to partition assembly, including:
    - 1) 4-inch stud walls with 5/8-inch gypsum board each side.
    - 2) 6-inch stud walls with 5/8-inch gypsum board each side.
  - d. Tape/screw Flanges: Nominal 7/8-inch.
  - e. Manufacturer: Provide "922 Series" Final Forms by Gordon or equivalent products manufactured by Fry Reglet Company, Flannery Company, or equal.
4. Reveal "Field" Trims: Provide for creating square-edged vertical and horizontal reveal lines in gypsum board wall assemblies where shown on Drawings.
- a. Depth: Nominal 5/8-inch for use with 5/8-inch gypsum board panels.
  - b. Reveal Width: As shown on Drawings.
  - c. Tape/screw Flanges: Nominal 7/8-inch.
  - d. Manufacturer: Provide "500 Series" double-sided Final Forms reveals by Gordon or equivalent products manufactured by Fry Reglet Company, Flannery Company, or equal.
5. Reveal "Edge" Trim: Provide for finished vertical and horizontal reveal edges at top and sides of gypsum board panels where shown on Drawings.
- a. Reveal Depth: Nominal 5/8-inch for use with 5/8-inch gypsum board panels.

- b. Reveal Width: As shown on Drawings.
  - c. Tape/screw Flanges: Nominal 7/8-inch.
  - d. Manufacturer: Provide "200 Series" Final Forms by Gordon or equivalent products manufactured by Fry Reglet Company, Flannery Company, or equal.
6. Reveal "Base" Trim: Provide for recessed base at bottom of gypsum board panels at floor where shown on Drawings.
- a. Reveal Depth: Nominal 5/8-inch for use with 5/8-inch gypsum board panels.
  - b. Reveal Width: 4-inches.
  - c. Tape/screw Flanges: Nominal 7/8-inch.
  - d. Manufacturer: Provide "800 Series" Final Forms by Gordon or equivalent products manufactured by Fry Reglet Company, Flannery Company, or equal.
7. Special Fabrications: Provide factory fabricated mitered assemblies for "T-intersections" and "X-intersections" where shown on Drawings.
8. Finish: Special trims to be primed and painted to match adjacent wall surfaces as specified in Section 099123 – Interior Painting.
- I. Adhesive for Laminating Board: As recommended by approved board manufacturer.
- J. Acoustical Sealant: As specified in Section 079200 – Joint Sealants.
- K. Electrical Box Sealer:
- a. Non-rated Locations: As specified in Section 079200 – Joint Sealants.
  - b. Fire-rated Locations: As specified in Section 078413 – Penetration Firestopping.
- L. Concealed, Non-Rated Access Panels: As specified in Section 08310 – Access Panels.

## PART 3 - EXECUTION

### 3.1 EXAMINATION

- A. Inspect areas and surfaces scheduled to receive gypsum board and verify that:
  - 1. Support systems are in proper alignment, straight and true.
  - 2. Required blocking, bracing and backing members of support systems are installed.
- B. Do not start work until unsatisfactory conditions are corrected.

## 3.2 PREPARATION

- A. Coordinate details with other work supporting, adjoining, or fastening to gypsum board.

## 3.4 INSTALLATION - INTERIOR GYPSUM BOARD

## A. General Requirements:

1. Apply and finish gypsum board in accordance with requirements of ASTM C 840 unless otherwise noted.
2. Cut gypsum board by scoring and breaking or sawing from face side. Smooth all cut edges and ends of gypsum board where necessary, in order to obtain neat jointing.
3. Scribe ceiling board neatly in casing bead where it meets surfaces in other planes.
4. Apply first to the ceiling at right angles to framing members, then to walls. Use boards of maximum practical length so that a minimum number of end joints occur.
5. Apply in either vertical or horizontal direction with ends and edges falling on framing members or other solid backing except where edge joints are at right angles to support. Bring ends and edges into contact with adjoining board, but do not force into place.
6. Lay out joints at openings so that no end joint aligns with edges of opening unless control joints will be installed at these points.
  - a. All joints running parallel to framing shall be centered as near as possible on face of framing member.
  - b. Stagger end joints and arrange joints on opposite sides of partition to occur on different studs.
  - c. At external corners, butt and fit board to provide solid edge.
7. Hold gypsum board nominal 1/4-inch above floor or curb typical.
8. Where gypsum board is carried full height to structure above, provide for deflection of structure by undercutting board nominal 3/8 inch and seal top edge of board to structure in continuous bead to form elastic closure.
9. Cut board to fit electrical outlets, pipes, or other items as required.
  - a. Cut gypsum board by scoring on face and back in outline before removal or by cutting with a saw or other suitable tool.
  - b. Smooth all cut out where necessary.
10. After trim is applied and prior to decoration, correct surface damage and defects.
11. Provide gypsum backer board gusset at double stud walls where studs are

less than 3-5/8 inches thick.

12. Fastening:

- a. Attach board from center to edges and ends, pressing firmly against supports. Place fasteners approximately not more than 1 inch nor less than 3/8 inch from edges with heads just below gypsum board surfaces; but do not break paper.
- b. Walls: Space screws maximum 12 inches on center for ceilings and maximum 16 inches on center for walls in field and along abutting edges.
- c. Suspended Ceilings: Space screws maximum 12 inches on center in field and along abutting edges.

B. Curved Surfaces:

1. Install panels horizontally (perpendicular to supports) and unbroken, to extent possible, across curved surface plus 12-inch-long straight sections at ends of curves and tangent to them.
2. 1/4-inch Board Application: For double-layer construction, fasten base layer to studs with screws 16 inches o.c. Center gypsum board face layer over joints in base layer, and fasten to studs with screws spaced 12 inches o.c.
  - a. Continue double layer 1/4-inch board application to closest adjacent inside or outside corners. Do not "shim" double board to align with adjacent 5/8 thick gypsum board.
3. Fire-rated Assemblies: Provide in strict conformance with referenced UL-listed assembly. Use on standard thickness type "X" board bent per manufacturer's written instructions.

C. Joint Treatment:

1. Apply tape and cement to joints and corners in strict accordance with directions of gypsum board manufacturer.
2. Pre-fill V-grooves formed by the abutting beveled or rounded wrapped edges with joint compound as per manufacturing recommendations.
3. Use tape and cement, allow to dry between coats. Use number of coats required by level of finish specified.
4. Work final coat to smooth level plane surface.
5. Protect external corners with metal corner beads unless otherwise noted.
6. Treat fastening head dimples same as joints; tape may be omitted.
7. Joints and fastening head dimples in backer board need only be treated as required to preserve fire rating.

8. Seal joints shown on Drawings and where gypsum board meets dissimilar material with specified sealant. Tool to neat surface, ready for paint; remove excess material.
- D. Fire-Rated Conditions:
1. At penetrations of rated assemblies, preserve continuity of fire rating with firestopping systems as specified in Section 07840 – Firestopping and Smoke Seals.
  2. Where adjacent interior spaces have suspended ceilings of different heights, extend separating partition finish on both faces of studs to at least 3 inches above higher ceiling finish.
  3. Conform to applicable codes and authorities for requirements of taping and cementing joints and fastener heads.
- E. Sound Retardant Partitions:
1. Construct partitions in accordance with Drawings and as herein specified.
  2. Hold face layers and base layers 1/4 inch clear from abutting surfaces, floors, walls and overhead structure. Seal with specified sealant and tape. Tape not required at floors.
  3. Provide airtight closures at wall penetrations (outlet boxes, pipes, duct work and other items) by neatly cutting gypsum board to clear penetrations. Seal void with specified sealant and apply joint tape to both gypsum board and penetrating object.
  4. Seal airtight the backs and sides of electrical junction boxes with resilient sealer pads.
- F. Furring over Recessed Light Fixtures: At non-rated lighting fixtures, construct furring from gypsum board as indicated on Drawings.
- G. Water-Resistant Board: During board application, coat all cut edges with approved water resistant adhesive as recommended by manufacturer for the application.
- H. Enclosure System: Install in strict accordance with requirements of approved manufacturer's system using metal components, gypsum components, and other accessories as required.
- I. Cementitious Backer Board:
1. General: Install cementitious backer board in strict conformance with the requirements of the tile assemblies specified in Section 093000 – Tile.
  2. Provide support systems so that all edges of cementitious backer boards are supported.
  3. Use only corrosion-resistant fasteners.

## 3.5 FINISHING INTERIOR GYPSUM BOARD ASSEMBLIES

- A. Levels of Gypsum Board Finish: Provide the following levels of gypsum board finish per USG "Gypsum Construction Handbook, Centennial Edition".
1. Level 1: for ceiling plenum areas, concealed areas, and where indicated, unless a higher level of finish is required for fire-resistive-rated assemblies and sound-rated assemblies.
  2. Level 2: where water-resistant gypsum backing board panels form substrates for tile, and where indicated.
  3. Level 3: Not used.
  4. Level 4: Not used.
  5. **Level 5: Typical, for all gypsum board surfaces unless otherwise indicated.**
- B. Level 4 gypsum board finish: Embed tape in joint compound and apply three separate coats of joint compound over joints, angles, fastener heads, and accessories. Touch up and sand between coats and after last coat as needed to produce a surface free of visual defects and ready for decoration. Use the following joint compound combination:
1. Embedding and First Coat: Ready-mixed, drying-type, all-purpose or taping compound.
  2. Fill (Second) Coat: Ready-mixed, drying-type, all-purpose or topping compound.
  3. Finish (Third) Coat: Ready-mixed, drying-type, all-purpose or topping compound.
- C. Where Level 5 gypsum board finish is indicated: apply joint compound combination specified for Level 4 plus a thin, uniform skim coat of joint compound over entire surface.
1. Use joint compound specified for the finish (third coat) or a product specially formulated for this purpose and acceptable to gypsum board manufacturer.
  2. Produce surfaces free of tool marks and ridges ready for decoration of type indicated.
- D. Where Level 2 gypsum board finish is indicated, apply joint specified for first coat in addition to embedding coat.
- E. Where Level 1 gypsum board finish is indicated, apply joint compound specified for embedding coat.
- F. Finish water-resistant gypsum backing board forming base for mortar-set ceramic tile to comply with ASTM C 840 and board manufacturer's directions for treatment of joints behind tile.
- G. Impact-Resistant Gypsum Board:

1. Construct partitions in accordance with Drawings and as herein specified.
2. General: Install to a height of no less than 4 feet above finish floor at locations shown on Drawings.

### 3.6 PARTITION IDENTIFICATION

- A. Identify partitions indicated on drawings as having a required fire or smoke rating.
  1. Follow guidelines set in Chapter 7 of International Building Code or as locally amended.
  2. Permanently identify with stenciling
    - a. Minimum 6 inches high letters with minimum ½ inch stroke.
    - b. Bottom of lettering to start at 6 inches above ceiling.
    - c. Stenciling to be 10 feet on center max.
    - d. Color : Red for 1-hr rated walls, Blue for 2-hr rated walls, Green for smoke partition walls.
    - e. Provide in a manner acceptable to authority having jurisdiction.

### 3.7 CLEANING AND PROTECTION

- A. Remedy any fastener popping or ridging.
- B. Promptly remove any residual joint compound from adjacent surfaces.
- C. Provide final protection and maintain conditions, in a manner suitable to Installer, that ensures gypsum board assemblies remain without damage or deterioration at time of Substantial Completion.

END OF SECTION



**SECTION 095100 – CEILING SUSPENSION**

## PART 1 - GENERAL

## 1.1 SUMMARY

- A. Work Included: Provide and install ceiling suspension systems, complete, as shown on Drawings and as specified for the following ceiling finish systems:
1. Gypsum Board Ceilings, coordinated with the Work of Section 09 29 0 – Gypsum Board.
  2. Lay-in Acoustical Ceilings, coordinated with the Work of Section 09 51 13 – Acoustical Ceilings.
  3. Lay-in Acoustical Ceilings for MRI rooms, including non-ferrous suspension components, coordinated with the Work of Section 09 51 13 – Acoustical Ceilings.
- B. Work Specified Elsewhere:
1. Section 01410 – Testing and Inspection Services
  2. Section 050500 – Metal Fasteners.
  3. Section 083113 – Access Panels.
  3. Section 092216 – Non Structural Metal Framing.
  4. Section 095113 – Acoustical Ceilings.
  5. Divisions 15 and 16 – Mechanical and Electrical Work in Suspended Ceilings.

## 1.2 REFERENCE STANDARDS

- A. American Society for Testing and Materials (ASTM):
1. C635; Standard Specification for Metal Suspension Systems for Acoustical Tile and Lay-In Panel Ceilings.
  2. C754; Standard Specification for Installation of Steel Framing Members to Receive Screw-Attached Gypsum.
  3. C841; Standard Specification for Installation of Interior Furring and Lathing.
  4. C1063; Standard Specification for Installation of Lathing and Furring for Portland Cement-Based Plaster.

5. C636; Standard Specification for Installation of Metal Suspension System for Acoustic Tile and Lay-In Panels.
  6. CISCA Ceiling Systems Installation Handbook.
- B. International Building Code (IBC) with 2003 Utah Amendments.

### 1.3 SUBMITTALS

- A. Comply with requirements of Section 01330 – Submittal Procedures.
- B. Samples:
1. Exposed Suspension System Components: 12-inch-long piece of each item specified.
- C. Shop Drawings: Show following:
1. Layout of suspension systems, location of hangers, seismic braces and trapezes, indicating location of fixed and free side of layouts.
  2. Hanger spacing and fastening details.
  3. Trapeze details.
  4. Splicing method for main and cross runners.
  5. Support at ceiling fixtures and air diffusers.
  6. Change in level details.
  7. Locations and dimensions of access panels, light fixtures, supply and exhaust grilles and diffusers, sprinkler heads, speakers, and detection devices.
  8. Seismic control details.
  9. Develop and coordinate location of all Work which is to be located in ceiling with the Sections involved per Section 01330 – Submittal Procedures prior to making shop drawing submittal.
- D. Product Data: Manufacturer's information on materials, fabrication, and installation. Provide certification of flame spread rating and UL classification.

### 1.4 QUALITY ASSURANCE

- A. Allowable Tolerances:
1. Deflection: Do not exceed a maximum of L/360 of span.
  2. Level: Do not deviate from level in excess of 1/8 inch in 12 feet.
- B. Testing:

1. If required by local authority, special inspection services may be implemented, refer to Section 01410 – Testing and Inspection Services.
2. Fasteners: As specified in Section 05050 – Metal Fasteners.

#### 1.5 PRE-INSTALLATION CONFERENCE

- A. Comply with requirements of Section 01315 – Project Meetings.
- B. Arrange a conference at the job site to coordinate interior wall, partition and ceiling installation, to be attended by the Owner, Architect, Contractor, and personnel involved in the actual manufacture and installation of the Work of the following Sections:
  1. Section 07220 – Acoustical Insulation.
  2. Section 07840 – Fire Stopping and Smoke Seals.
  3. Section 09110 – Interior Wall Framing.
  4. Section 09120 – Ceiling Suspension.
  5. Section 09250 – Gypsum Board.
  6. Section 09265 – Shaft Wall Systems.
  7. Section 09510 – Acoustical Ceilings.
  8. DIVISION 15 – Mechanical.
  9. DIVISION 16 – Electrical.

#### 1.6 PRODUCT HANDLING

- A. Delivery: Deliver products and materials in original unopened packages, containers, or bundles with manufacturer's label intact and legible.
- B. Damaged Items: Remove items delivered in broken, damaged, rusted, or unlabeled condition from Project site immediately.
- C. Manufacturer's Recommendations: Follow additional delivery, storage, and handling requirements of manufacturer.

#### 1.7 PROJECT CONDITIONS

- A. Concealed Work: Ensure that work concealed by suspended ceilings be complete, tested if required, inspected, and approved prior to commencement of installation of materials specified herein.
- B. Environmental Conditions: Do not commence installation until area has been closed in, and temperature and humidity conditions are similar to those expected during building occupancy.

- C. Wet Work: Complete and cured, prior to commencement of installation of suspended ceilings.

## PART 2 - PRODUCTS

### 2.1 MATERIALS

A. Framing:

1. General: Types specified are products of Western Metal Lath Company. Structural characteristics and quality of substitutions shall meet or exceed those of types specified and referenced standards.
2. Main Runners: 1-1/2-inch-deep cold-rolled (0.475 pound/foot) or hot-rolled (1.12 pound/foot) steel channels, galvanized for exterior work and rust-inhibitive coated for interior work.
3. Cross Furring: 3/4-inch-deep cold- or hot-rolled (0.3 pound/foot) steel channels, galvanized for exterior work and rust-inhibitive coated for interior work.
4. Furring Channels: 7/8-inch hat-shaped channels, 25-gauge hot-rolled channel at gypsum board ceilings; rust inhibitive finish.
5. Clips: Galvanized steel, of sizes and shapes shown. 16-gauge, except as otherwise shown.

B. Fasteners:

1. Sheet Metal Screws: To suit channel gauge, as specified in Section 09110 – Metal Support Systems.
2. Expansion Bolts:
  - a. Tie Wire: Hilti Kwik Bolt HKT 14, Ramset/Red Head TW, or equal, with minimum 1-1/2-inch embedment.
  - b. Others: As specified in Section 05050 – Metal Fasteners.
3. Powder-Actuated Devices (PAD's):
  - a. As specified in Section 05050 – Metal Fasteners and as follows:
    - 1) Size: 0.145-inch diameter with 15/16-inch minimum penetration.
    - 2) For Attachment of Ceiling Clips: Hilti DN 27 P8T, or equal.
4. Pop Rivets: 3/16-inch-diameter plated steel.
5. Machine Bolts: ASTM A307, Grade A, regular hexagon head type with ASTM A563, Grade A nuts. 1/4-inch size unless otherwise shown.

- C. Hanger, Bracing and Tie Wires:
1. FS QQ-W-461H, Finish 5, Class 1, soft temper or ASTM A 641, Class 1 coating, soft temper.
  2. Minimum gauges:
    - a. Hangers, 8.
    - b. Diagonal bracing wire, 12.
    - c. Single-strand tie wire, 16.
    - d. Double-strand tie wire, 18.
- D. Welding Electrodes: AWS, low hydrogen type, as required.
- E. Ceiling Clips: "BERC2" Clips in conformance with IBC Seismic category D, E, and F requirements for specified ceiling grid systems.
- F. Seismic Brace:
1. General: Provide compression post and four 12-gauge galvanized steel wires splayed at 45 degrees vertically and spaced at 90 degrees horizontally to each other and attached to main runner or grid member with 2-inches of compression post.
  2. Wire Attachment: PAD devices not permitted for attachment of brace wires. Fasten bracing wires at each end with not less than 4 tight turns within distance of 1-1/2 inches, except machine made wire turns, where both strands have been deformed or bent in wrapping, need not comply with 1-1/2-inch distance requirement as long as turns are tight as possible and four in number.
- G. Compression Posts: Provide compression posts as shown on Drawings and as specified, including:
1. Angle Strut Type: Steel sheet angles or channels, not less than 16-gauge, L/R ratio of 200 maximum.
  2. EMT Type: Electrical metallic tubing, diameters shown.
  3. Metal Stud Type: 2-inch by 4-inch steel stud, 16-gauge. Attach to main channel with three No. 10 screws. Attach to structure per drawings.
  4. Proprietary Type: Use at Contractor's option in lieu of angle strut or EMT types. USG's Donn Series VSA Compression Post, or equivalent, galvanized steel telescoping post with top clip, bulb clip, guide ring, and locking device. Provide size recommended by manufacturer for span.
- H. Suspension System for Acoustical Ceilings:

1. General: Provide each component as products of a single manufacturer.
2. Type: Comply with ASTM C 635 Structural Classification as "Heavy Duty" Systems, for direct hung installation with interlocking main runners and cross runners. Roll-formed grid components composed of double web hot-dipped galvanized steel.
  - a. Structural Classification: UL Certified in compliance with CBC Chapter 16 criteria.
3. Manufacturer: CertainTeed, Armstrong World Industries; USG Interiors, Inc; Chicago Metallic;. Products from CertainTeed are the Basis-of-Design for coordinated suspension components and acoustical ceiling panels.
4. Grid System:
  - a. For use with the following acoustic ceiling types: ACP-1, ACP-2, ACP-3 and ACP-4 as specified in Section 09 51 13 – Acoustical Panel Ceilings
  - b. Manufacturer: CertainTeed
  - c. Type: CertainTeed Classis Stab System, Heavy duty 15/16" Tee System; and 15/16" wall molding; including CertainTeed Seismic Perimeter Clip for seismic categories D, E and F.
  - d. Surface Finish: Baked polyester paint. Color: White
5. Typical Perimeter Angles: With matching corner caps and splice pieces; same material as that of exposed suspension system members, 15-gauge with hemmed edge, typical.
  - a. Finish: Baked polyester paint. Match adjacent grid system.
7. Slip Joints: MM Systems Corp.'s Series DX-100, or equal, white polyvinyl-chloride flexible extrusion for 1-inch-wide joint.
8. Slotted Angle Spacer: Slotted angles or channels with spring steel diamond points which snap tight to prevent movement of strut.
9. Miscellaneous Accessories: Manufacturer's standard for use with suspension system furnished; furnish as required.
- I. Sound Isolation Clips: As specified in Section 09110 – Non-Load Bearing Wall Framing.
- J. Miscellaneous: Provide manufacturer's standard miscellaneous items and accessories suitable for use intended and required for complete installation.

## PART 3 - EXECUTION

## 3.1 EXAMINATION

- A. Verification of Conditions: Examine conditions under which ceiling suspension systems are to be installed. Give notification in writing, of conditions detrimental to proper and timely completion of Work. Proceed only when conditions are satisfactory.

## 3.2 INSTALLATION

- A. Hanger Wires:
1. Spacing:
    - a. For Gypsum Board, Metal Ceilings, and Acoustical Ceilings: 4-foot centers maximum.
  2. Clearance: Not less than 6-inches between hanger wires and unbraced ducts, pipes, and conduit.
  3. Attachment to Structure Above: Use wire pigtail embedded in concrete, tie wire type expansion bolt, or PAD with ceiling clip, as appropriate.
  4. Hanger Wires: Fasten hanger wires to attachment device at structure above with not less than 3 tight turns within distance of 1-1/2-inches, except machine-made wire turns, where both strands have been deformed or bent in wrapping, need not comply with 1-1/2-inch distance requirement as long as turns are as tight as possible and 3 in number.
  5. Wire Size:
    - a. For Gypsum Board Soffits and Ceilings: 8-gauge.
    - b. For Acoustical and Metal Panel Ceilings: 12-gauge at inaccessible and 10-gauge at accessible areas.
  6. Out-Of-Plumb Wires: Install hanger wires as near plumb as possible. Where hanger wires are more than 1 (horizontal) to 6 (vertical) out of plumb, provide counterbrace wires.
- B. Trapezes: Provide trapezes or other supplementary support members at obstructions in order to maintain specified hanger spacing. Provide additional hangers, struts or braces as required at all ceiling breaks, soffits or discontinuous areas. Counter-balance out-of-plumb wires as specified.
- C. Additional Hanger Wires: Provide as required at ceiling breaks, soffits, and discontinuous areas.
- D. Gypsum Board Ceiling Suspension System:
1. Runner Channels:

- a. Spacing: 4-foot maximum centers.
  - b. Attachment: Saddle tie with hanger wires at 4-foot maximum centers. Make 2 loops and secure with not less than 3 turns in 1-1/2-inch maximum distance.
  - c. Splice: Lap and interlock flanges 12 inches minimum and tie near each end with double loops of 16-gauge tie wire.
2. Furring Channels:
    - a. Spacing: 16-inch maximum centers.
    - b. Attachment: Saddle tie with 16-gauge tie wire to runner channels and secure with no less than 3 tight turns.
    - c. Splice: Lap and interlock 8-inches minimum and tie near each end with double loops of 16-gauge tie wire.
- E. Acoustical Ceiling Panel and Metal Ceiling Panel suspension system:
1. General: Install per Reference Standards, manufacturer's instructions, and reviewed shop drawings.
  2. Main Grid Members:
    - a. Spacing: 4-foot maximum centers.
    - b. Attachment: Tie with hanger wire secured with not less than 3 turns in 1-1/2-inch maximum distance.
    - c. Lighting Fixtures, Air Terminals, and Other Services Less Than 56 Pounds in Weight: Secure with slack hanger wires at two corners.
    - d. Lighting Fixtures, Air Terminals, and Other Services Greater Than 56 Pounds in Weight: Secure with hanger wires at four corners and as shown on Drawings.
  3. Secondary Grid Members:
    - a. Spacing: 2-foot maximum centers.
    - b. Attachment: Form 2-foot by 2-foot grid with positive splices.
- F. Seismic Restraint:
1. General: Provide as follows for each type suspension system.
  2. Spacing:
    - a. Areas Less Than 96-Square Feet:



- 1) No Dimension Greater Than 12-Feet: No bracing required.
  - 2) Dimension Greater Than 12-Feet: Provide bracing.
  - b. Areas Greater Than 96-Square Feet: Provide brace for each 96-square feet or fraction thereof.
  - c. Maximum Brace Spacing: 8-feet by 12-feet.
  - d. Maximum Distance From Walls: 1/2-brace spacing in direction perpendicular to plane of wall.
3. Seismic Brace:
- a. General: Provide compression post and four 12-gauge galvanized steel wires splayed at 45 degrees vertically and spaced at 90 degrees horizontally to each other and attached to main runner or grid member with 2-inches of compression post.
  - b. Wire Attachment: Powder-actuated devices not permitted for attachment of brace wires. Fasten bracing wires at each end with not less than 4 tight turns within distance of 1-1/2-inches, except machine made wire turns, where both strands have been deformed or bent in wrapping, need not comply with 1-1/2-inch distance requirement as long as turns are as tight as possible and 4 in number.
- I. Access Panels: Frame as required for access panels furnished under Divisions 15 and 16 and specified under Section 08310 –Access Panels.

END OF SECTION

**SECTION 095113 – ACOUSTICAL PANEL CEILINGS**

## PART 1 - GENERAL

## 1.1 SUMMARY

- A. Work Included: Provide and install acoustical ceilings panels and accessories, complete, as shown and specified, including:
  - 1. Mineral core acoustical ceiling panels.
- B. Work Specified Elsewhere:
  - 1. Section 092216 – Non-Structural Metal Framing.
  - 2. Section 122200 – Curtains and Drapes.
  - 3. Division 23 – Mechanical (Air Supply, Ducts, and Connections).
  - 4. Division 26 – Electrical (Lighting Fixture Attachments).

## 1.2 REFERENCE STANDARDS

- A. American Society for Testing and Materials (ASTM):
  - 1. C635; Metal Suspension Systems for Acoustical Tile and Lay-In Panel Ceilings.
  - 2. C636; Standard Practice for Installation of Metal Ceiling Suspension Systems for Acoustical Tile and Lay-In Panels.
- B. Ceiling and Interior System Contractors Association (CISCA):
  - 1. Ceiling Systems Handbook.

## 1.3 SYSTEM DESCRIPTION

- A. Performance Criteria:
  - 1. Fire-Hazard Classification: Provide acoustical ceilings that are identical to those tested for following fire hazard characteristics, per ASTM test method indicated below, by UL or other testing and inspecting organizations acceptable to authorities have jurisdiction. Identify acoustical ceiling components with appropriate markings of applicable testing and inspecting organization.
    - a. Test Method: ASTM E84.
    - b. Flame Spread: 25 or less.
    - c. Smoke Developed: 50 or less.

## 1.4 SUBMITTALS

- A. Comply with requirements of Section 013300 – Submittal Procedures.
- B. Product Data: Manufacturer's specifications, data, and installation instructions.
- C. Shop Drawings:
  - 1. Coordination Drawings: Reflected ceiling plans drawn accurately to scale and coordinating penetrations and ceiling-mounted items. Show following:
    - a. Ceiling suspension members.
    - b. Method of attaching hangers to building structure.
    - c. Ceiling-mounted items including light fixtures; air outlets and inlets; speakers; sprinkler heads; and special moldings at walls, column penetrations, and other junctures with adjoining construction.
- D. Samples:
  - 1. For Initial Selection: Manufacturer's standard sample sets consisting of actual acoustical units or sections of units showing full range of colors, textures, and patterns available for each type of unit indicated.
  - 2. For Verification: 12-inch-square sample of each type of exposed finish specified or selected and of same thickness and material indicated for final unit of Work. Where finishes involve normal color and texture variations, include sample sets showing full range of variations expected.
- E. Qualification Data: For firms and persons specified in Quality Assurance article to demonstrate their capabilities and experience. Include list of completed projects with project names, addresses, names of Architects and Owners, and other information specified.
- F. Research Reports: Or evaluation reports of model code organization acceptable to authorities having jurisdiction that show compliance of acoustical ceiling system and components with building code in effect for Project.
- G. Product Test Reports: From qualified independent testing agencies that are based on its testing or current products for compliance of acoustical ceiling systems and components with requirements.

#### 1.5 QUALITY ASSURANCE

- A. Qualifications of Installer: Engage experienced Installer who has successfully completed acoustical ceilings similar in material, design, and extent to those indicated for Project.
- B. Single-Source Responsibility: Obtain each type of acoustical ceiling unit from single source with resources to provide products of consistent quality in appearance and physical properties without delaying progress of Work.

- C. Coordination of Work: Coordinate layout and installation of acoustical ceiling units and suspension system components with other construction that penetrates ceilings or is supported by them, including light fixtures, HVAC equipment, fire-suppression system components (if any), and partition system (if any).

#### 1.7 PRODUCT HANDLING

- A. Delivery and Storage: Deliver acoustical ceiling units to Project site in original, unopened packages and store them in fully enclosed space protected against damage from moisture, direct sunlight, surface contamination, and other causes.
- B. Handling: Handle acoustical ceiling units carefully to avoid chipping edges or damaging units in any way.

#### 1.8 PROJECT CONDITIONS

- A. Storage: Before installing acoustical ceiling units, permit them to reach room temperature and stabilized moisture content.
- B. Space Enclosure: Do not install acoustical ceilings until space is enclosed and weatherproof, wet-work in space is completed and nominally dry, work above ceilings is complete, and ambient conditions of temperature and humidity will be continuously maintained at values near those expected for final occupancy.

### PART 2 - PRODUCTS

#### 2.1 MINERAL CORE ACOUSTICAL PANELS

- A. Manufacturer: Provide products manufactured by Armstrong World Industries; USG; or equal.
  - 1. Basis-of-Design: Armstrong World Industries products are specified as the basis of design.
- B. Mineral Core Acoustical Panel Types:
  - 1. Type 1:
    - a. General: Armstrong Ultima Health Zone (Item # 1935)
    - b. Size: 24 inches by 24 inches by 3/4-inch-thick.
    - c. Edge Detail: Square Lay-In.
    - d. Noise Reduction Coefficient: UL Classified NRC of 0.70 in compliance with ASTM C423.
    - e. Sound Transmission Class: UL Classified CAC minimum of 38 in compliance with ASTM E1414 or ASTM E413.
    - f. Light reflectance: 0.86

- g. Provide manufacturer's coordinated field and border units, as required by layouts shown on Drawings.
- h. Specified grid system: Armstrong's Prelude XL 15/16-inch exposed tee.

### PART 3 - EXECUTION

#### 3.1 EXAMINATION

- A. Verification of Conditions: Examine substrates and structural framing to which ceiling system attached or abuts, with Installer present, for compliance with requirements specified in this and other sections that affect installation and anchorage of ceiling system. Do not proceed with installation until unsatisfactory conditions have been corrected.

#### 3.2 INSTALLATION

- A. General: Install acoustical ceiling systems per Reference Standards and manufacturer's instructions.
- B. Acoustical Ceiling Tiles:
  - 1. General: Make joints straight and true to line with exposed surfaces flush and level. Tightly butt tiles with corners and arises full and without broken edges.
  - 2. Suspended System:
    - a. Concealed Grid: Install tile with concealed metal splines in kerfed edges between tiles to form concealed mechanical joints.
    - b. Edge Units: Install spring steel spacers where supported on edge trim.
    - c. Access Tile: Install units by concealed saddle and notched hook spline method.
    - d. Identification Markers: Install one per access tile; locate on tile as directed.

#### 3.3 CLEANING

- A. Cleaning: Clean exposed surfaces of acoustical ceiling panels. Comply with manufacturer's instructions for cleaning and touch-up of minor finish damage. Remove and replace work that cannot be successfully cleaned and repaired to permanently eliminate evidence of damage.

END OF SECTION

**SECTION 096519 – RESILIENT FLOORING**

## PART 1 - GENERAL

## 1.1 SUMMARY

- A. Work Included: Provide and install resilient flooring, resilient base and accessories, complete as shown on Drawings and as specified, including:
1. Luxury Vinyl Tile
  2. Homogeneous sheet vinyl, heat welded including integral coved base.
  3. Resilient Base.
  4. Edge Strips, Reducer Strips and other floor-edge transitions.
  5. Cap trim, cove-shaped furring, and accessories for cove base installations.
  6. Hot Weld Strips and cold seam materials.
  7. Adhesives and other accessory materials as required to provide complete floor assemblies as specified.
- B. Work Specified Elsewhere:
1. Section 035300 – Concrete Toppings.
  2. Section 087100 – Door Hardware.
  3. Section 093000 – Tile.

## 1.2 REFERENCE STANDARDS

- A. Resilient Floor Covering Institute (RFCI).
- B. American Society for Testing and Materials (ASTM):
1. ASTM E-1907-98: "Standard Practices for Determining Moisture-Related Acceptability of Concrete Floors to Receive Moisture-Sensitive Finishes".

2. ASTM F-1869-89: "Standard Test Method for Measuring Moisture Vapor Emission Rate of Concrete Subfloor Using Anhydrous Calcium Chloride".

### 1.3 SUBMITTALS

- A. Comply with requirements of Section 013300 – Submittal Procedures.
- B. General: Schedule submittals as required to provide a minimum of 60-days from flooring materials order day to start of installation.
- C. Shop Drawings: Provide seaming diagrams for public spaces including corridors.
- D. Samples:
  1. Edge, Reducer and Transition Strips: Each specified type and color, 12 inches long.
  2. Resilient Tile Flooring: 2 samples, each type and color specified, 12 inches square.
  3. Resilient Sheet Flooring: 2 samples, each type and color specified, 12 inches square.
  4. Resilient Base: 2 samples each type and color, 12 inches long. None required for black color.
- E. Product Data: Manufacturer's specifications, data, and installation instructions.
- F. Qualifications: Submit Contractor's and Installer's project lists and specified manufacturer certifications, including project names and addresses and contact names and telephone numbers.
- G. Maintenance Manuals: Manufacturer's written maintenance instructions.

### 1.4 QUALITY ASSURANCE

- A. Qualifications of Installer: Minimum of three project installations of extent comparable to proposed Project.
- B. Regulatory Requirement: Materials shall have the following flammability ratings, according to NFPA 253:
  1. Smoke Density: 45 or less.

2. Critical Radiant Flux: Class I - Minimum 0.45 watts per square centimeter. (Class II - Minimum 0.22 watts per square centimeter.)
- C. Slip Resistance: Static coefficient of friction for installed flooring shall be equal to or greater than .06 when measured with a James Machine per ASTM D2047.

#### 1.5 PRODUCT HANDLING

- A. Comply with requirements of Section 016000 – Product Requirements.
- B. Delivery: Deliver materials to Project site in manufacturer's unopened containers clearly marked with manufacturer's name, brand, size, thickness, grade, color, graining, and design.
- C. Storage: Store materials per manufacturer's recommendations and at not less than 70 degrees F for at least 24 hours before installation.

#### 1.6 PROJECT CONDITIONS

- A. Environmental Requirements: Maintain temperature in spaces to receive resilient flooring at 70 degrees F minimum at least 48 hours before, during, after installation; thereafter, maintain a 55 degrees F minimum.

### PART 2 - PRODUCTS

#### 2.1 GENERAL

- A. Basis-of-Design: Tile Products as scheduled on the Drawings provide a "Basis-of-Design" for each scheduled Resilient Flooring Product and have been selected and approved for use by the Owner based manufacturer's samples provided to the Architect, and have been fully coordinated with finish materials specified elsewhere.
- B. Resilient Flooring substitution requests will only be considered for acceptance by the Architect when the following conditions are met:
  1. Proposed substitution Resilient Flooring meets or exceeds the specified material, construction and performance criteria.
  2. Proposed Resilient Flooring substitution visually matches scheduled types for thickness, textures, patterns, color, and reflectance and other surface characteristics as determined by the Architect.
  3. Acceptance of a proposed substitution Resilient Flooring by the Architect shall incur no additional cost to the Owner, including costs incurred to re-select adjacent finishes specified elsewhere



as required to coordinate and match substituted Resilient Flooring for color, texture or pattern.

## 2.2 RESILIENT BASE AND ACCESSORIES

- A. Manufacturer: Provide products manufactured by Mannington or Roppe.
- B. Adhesive for Resilient Bases: Waterproof type recommended in writing or supplied directly by base manufacturer.
- C. Resilient Base Materials: Thermoplastic Rubber, Type TP- Premium Edge wall base. Finish: Smooth Matte Finish. Corners- Factory pre-formed. Thickness- 1/8"; 4-foot minimum length.
  - 1. Provide colors as scheduled on Drawings and specified and as required to match Architect's samples.
  - 2. Provide manufacturer's standard black at casework bases.
- D. Resilient Base Types:
  - 1. Rubber Wall Base by Mannington Commercial.
    - a. Color: As scheduled on Drawings.
    - b. Height: 4-inches.
    - c. Seal rubber base to resilient flooring with continuous clear silicon sealant.
- E. Locations: Provide resilient base at locations shown or scheduled on Drawings, including:
  - 1. Exposed, Sealed and Painted Concrete floors.
  - 2. Floors finished with materials specified in this Section.
  - 3. Plywood.

## 2.3 HOMOGENEOUS SHEET VINYL FLOORING

- A. General: Provide PVC-Free Resilient Sheet Flooring in conformance with ASTM F-1303, Type I, Grade 1, Class B Backing, for types, compositions, and other characteristics indicated.
  - 1. Manufacturer: Provide "**BIOSPEC MD**" by **Mannington Commercial Flooring**.

2. Homogeneous Vinyl Flooring Types:
  - a. As scheduled on Drawings.
- B. Performance Requirements:
  1. Fire Resistance: 450 or less when tested per ASTM E-662/NFPA 258 (Smoke Density), 0.45-watts/cm<sup>2</sup> or better (Class 1 or better) when tested per ASTM E-648/NFPA 253 (Critical Radiant Flux).
  2. Static Load Limit: 750-pounds per square inch or better when tested per ASTM F-970.
  3. Slip Resistance: equal or exceed specified requirements.
- C. Homogeneous Sheet Vinyl Flooring Accessories:
  1. Adhesive: Provide Solvent-free Adhesives recommended by each Homogeneous Sheet Vinyl Flooring Manufacture in writing for use with each type of specified Homogeneous Sheet Vinyl Flooring and for the actual conditions at the project area.
    - a. Adhesive Trowel: Use appropriate trowel tooth patterns as recommended by the Adhesive Manufacturer in writing for use with the specified Homogeneous Sheet Vinyl Flooring types.
  2. Sub-Floor Primer and Sealer: Provide sub-floor Sealers or Primers where recommended by the Resilient Sheet Flooring Manufacturer(s) in writing where required by the Sub-Floor conditions at the project area at the project area noted during verification of conditions.
  3. Welding Rods: For Homogeneous Sheet Vinyl Flooring shown on Drawings or scheduled to receive heat-welded seams, provide 4-mm welding rod as recommended in writing by the manufacturer of each specified type of Flooring. Provide single-sourcing of welding rods and sheet vinyl flooring for each specified type of Resilient Sheet Flooring.
    - a. Colors: Provide welding rods to match Architect's samples or as selected by Architect from manufacturer's full range of colors.
  4. Homogeneous Sheet Vinyl Flooring Initial Cleaning: Typical at all locations, follow Resilient Sheet Flooring manufacturer's written instructions recommending process and product for each specified type.

- a. Finish Sheen: to be Matte.

## 2.4 LUXURY VINYL TILE

- A. General: Provide Luxury Vinyl Tiles and Planks in conformance with ASTM F-1700, Class 3, Type B for types, compositions, and other characteristics indicated.
  1. Manufacturer:
    - a. Provide 12" x 24" LVT "**NO RESERVATION XPRESS, NR302, VAST**" by **Mannington Commercial Flooring**.
  2. Luxury Vinyl Tile Types:
    - a. As scheduled on Drawings.
- B. Performance Requirements:
  1. Fire Resistance: 450 or less when tested per ASTM E-662/NFPA 258 (Smoke Density). 0.45-watts/cm<sup>2</sup> or better (Class 1 or better) when tested per ASTM E-648/NFPA 253 (Critical Radiant Flux).
  2. Static Load Limit: 750-pounds per square inch or better when tested per ASTM F-970.
  3. Slip Resistance: equal or exceed specified requirements.
- C. Luxury Vinyl Tile Accessories:
  1. Adhesive: Provide Solvent-free Adhesives recommended by the Luxury Vinyl Tile Manufacturer(s) in writing for use with each type of specified Vinyl Composition Tile and for the conditions at the project area.
    - a. Adhesive Trowel: Use appropriate trowel tooth patterns as recommended by the Adhesive Manufacturer in writing for use with the specified Luxury Vinyl Tile types.
  2. Sub-Floor Primer and Sealer: Provide sub-floor Sealers or Primers where recommended by the Luxury Vinyl Tile Manufacturer(s) in writing where required by the Sub-Floor conditions at the project area at the project area noted during verification of conditions.
  3. Luxury Vinyl Tile Sealer: Typical at all locations, provide sealer coat for Luxury Vinyl Tile floors as recommended by each Luxury Vinyl Tile manufacturer in writing for each specified type.

4. Wax for Luxury Vinyl Tile: not recommended.

## 2.7 MATERIALS FOR COVERED BASE AT RESILIENT FLOORS

- A. General: Provide materials as required to install cove base at locations shown or scheduled on Drawings. Not all specified resilient sheet flooring types may require cove base; some resilient flooring types may be scheduled to receive several base treatments, including cove base.
- B. Materials:
  1. Fillet Cove Strips: Provide redwood cove strips as recommended by each specified resilient sheet flooring manufacturer in writing to coordinate with each specified resilient sheet flooring type.
  2. Outside Corner for Resilient Sheet Coved Base: Provide the each specified manufacturer's outside pre-molded corner to match each specified resilient sheet flooring type. Provide types and color(s) as scheduled on Drawings and as specified.
  3. Cap Strip: Extruded aluminum, clear anodized. Single-source one cap strip type and finish for use through-out entire scope of project. Provide cap strips in the longest length practical to minimize butt joints.

## 2.8 REDUCER STRIPS, EDGE STRIPS AND TRANSITIONS

- A. Manufacturer: Where Manufacturer's standard products are scheduled on Drawings and specified, provide the specific products indicated or materials complying with the requirements set forth in this Section.
- B. Adhesive for reducer, edge and transition strips: Waterproof type recommended in writing or supplied directly by base manufacturer.
- C. Locations: Provide reducer, edge and transition strips at locations where different floor finishes meet, as required to protect the transition joint and/or provide a gentle transition between floor finishes of differing thicknesses, including:
  1. Exposed, Sealed and Painted Concrete floors: to any other floor finish.
  2. Section 093000 – Tile: to any floor finish specified in this Section and Section 096813 – Tile Carpeting.
  3. Floor finishes specified in this Section:

- a. All locations between two different floor finish materials specified in this Section.
  - b. Between two different floor finish colors of the same material specified in this Section when shown or scheduled on Drawings.
  - c. Between floor finishes specified in this Section and at transitions to carpet specified in Section 096813 – Tile Carpeting.
- D. Manufacturer: Provide reducer, edge and transition strips by Johnsonite, Mercer, or approved equal.
1. Provide reducer, edge and transition strips at all level differences in flooring. Center on door frame where possible.
    - a. Colors: As selected by the Architect from the manufacturer's full range of standard colors.

## PART 3 - EXECUTION

### 3.1 EXAMINATION

- A. Verification of Conditions: Examine substrates and adjoining construction and conditions under which Work will be installed. Give written notification of deficiencies detrimental to proper or timely installation; do not proceed until corrected.
- B. Slab Moisture Test:
1. General: Test substrates to determine acceptable dryness prior to application of resilient flooring. Use ASTM F-1869-89, "Standard Test Method for Measuring Moisture Vapor Emission Rate of Concrete Subfloor Using Anhydrous Calcium Chloride", as applicable for the specified flooring as recommended by resilient flooring manufacturer.
  2. Slab-Moisture Content Testing: Perform tests at locations not more than 50 feet apart in every direction, but no less than one test per 1000-square feet. Verify the following performance criteria are equaled or exceeded before beginning floor installation:
    - a. Vapor and moisture barrier shall reduce vapor transmissions from concrete slabs-on-grade and above-grade concrete and metal deck assemblies to 3 pounds or less per 1000-square feet in a 24-hour period when tested per ASTM F-1869-89.

- b. Alkalinity: Maximum pH of 10.
    3. Contingency for High Moisture Readings: Report all unacceptable test results to Architect.
  - C. Air-Moisture Content Testing:
    1. General: Determine relative humidity of air in rooms to receive resilient flooring, using wet-bulb and dry-bulb sling psychrometer. Do not install resilient flooring when relative humidity exceeds 45 percent.
  - D. Adhesion Test:
    1. Secure one, three-foot-square piece of each specified type of resilient sheet or 3-foot by 3-foot area of each specified type of tile in each typical area that has passed the specified moisture test, using adhesive(s) as specified and recommended by manufacturer(s).
    2. The test pieces shall remain in place for 72 hours.
    3. Determine if the adhesive is bonding the material satisfactorily to the surface. Resilient flooring should not be able to be removed without severe deformation, tearing, or destruction of the sample(s).
    4. Where there is evidence of unsatisfactory bonding, manufacturer's representative is to be notified in order that they may verify and evaluate the conditions.
    5. Notify Architect immediately if, in the opinion of manufacturer's representative, the adhesion test results are unsatisfactory.
    6. Remove successful test pieces and adhesive prior to commencing final installation.

### 3.2 PREPARATION

- A. Surface Preparation: Clean substrate of deleterious materials which impair bonding of resilient flooring. Do Work on smooth, even troweled finish. Remove rough areas and protrusions from concrete by griding. Fill cracks, rough areas, and other surface defects with an acceptable plastic filler.
- B. Primer/Sealer Coat: Apply primer to concrete surfaces; work well into surfaces; use minimum quantity that will assure complete surface

coverage with a non-absorptive base. Allow primer to thoroughly dry before applying adhesive.

1. Prime coat may be omitted if recommended by resilient flooring manufacturer in writing based on review of the project area. Review the requirements for each specified type of resilient flooring for each project area.
2. Do not combine different specified flooring types under one manufacturer's recommendation.

### 3.3 INSTALLATION

#### A. Edge Strips:

1. General: Install in continuous lengths at door openings and other exposed edges of resilient flooring, unless otherwise shown. Install edge strips before applying primer.
2. Metal: Anchor strips solidly to substrate with countersunk non-magnetic stainless steel screws; use lead shields for anchoring into concrete; space screws 1-inch from each end and not more than 9-inch centers at intermediate points.
3. Vinyl: Set in and securely bond to substrates with adhesive per manufacturer's recommendations.

#### B. Prime Coat: Apply primer to concrete surfaces; work well into surfaces; use minimum quantity that will assure complete surface coverage with a non-absorptive base.

- a. Allow primer to thoroughly dry before applying adhesive.
- b. Prime coat may be omitted if recommended by resilient flooring manufacturer.

#### C. Adhesive: Apply to substrate with properly notched steel trowels; allow adhesive to become tacky before applying resilient flooring.

#### D. Resilient Flooring: Extend flooring, and fit neatly and tightly, into breaks and recesses, against bases, around pipes and penetrations, around permanent casework, equipment, and under-casework recesses.

#### E. Sheet Material:

1. General: Lay sheet material with minimum number of joints with bottom surface securely bonded to substrate and top surface left smooth, clean, and free from imperfections.

- a. Make joints straight, tight, and inconspicuous.
- b. Roll each sheet from center to edges to assure complete bond and tight joints.
2. Joints: Provide Chemically Weld; Adhesive Weld; Heat Weld as scheduled on Drawings and in conformance with sheet flooring manufacturer's written instructions.
3. Distance between seams to be eight feet minimum. Provide shop drawings showing seam locations for approval before installation.
4. Coved Bases:
  - a. Install a continuous redwood cove strip at intersection of floor and vertical surfaces prior to laying sheet material.
  - b. Use cove strip with a 3/4-inch radius; make bases 4 inches high, unless otherwise shown; butt ends; miter corner; secure with acceptable type fasteners.
  - c. Apply cove strips and sheet material to solid backing.
  - d. Roll sheet material into adhesive; hold in place until complete adhesion is assured. **DO NOT USE DOUBLE STICK TAPE FOR THIS APPLICATION. BASE TO BE FULLY ADHERED TO WALL WITH GLUE TYPE ADHESIVE.**
  - e. Make top of base level and straight; terminate top edge into a metal trim cap.
  - f. Securely screw trim cap to backing before applying sheet material; use single lengths where possible; make neat mitered corners and butted ends.
  - g. Use standard aluminum alloy or stainless steel trim cap of standard design as selected, unless otherwise shown.
4. Perimeter Bond System: At Contractor's option, a perimeter bond system may be used for installation of sheet vinyl flooring.
  - a. Do work with manufacturer's approved and trained applicators per manufacturer's recommendations and supervision.
  - b. Install sheet vinyl flooring with adhesive spread only at seam lines, projections, and wall lines.



- c. Cut seams with an electrically operated cutting machine made for purpose.

F. Resilient Bases:

1. General: Where base is scheduled, install around perimeter of room or space, at base of partitions, walls, columns, pilasters, casework, and other permanent fixtures.
  - a. Install top-set coved type bases throughout, except install straight type bases at carpet.
  - b. Secure bases to surfaces with waterproof adhesive; make joints tight; keep top and bottom edges in firm contact with adjacent surfaces.
    - 1) Provide a continuous seal of the resilient base to both the wall surface at the upper edge and the floor surface at the bottom edge.
  - c. Use longest lengths possible; straight pieces less than 24 inches long not permitted.
  - d. Miter or cope inside corners.
2. Coved Type: Provide with premolded end stops and premolded one-piece external corners.
3. Straight Type: Provide with preformed one-piece external corners.
4. Edges and Seams: Match edges at seams. Double cut adjoining lengths. Make tight butt joints.

### 3.4 CLEANING

- A. General: Not more than four days before Substantial Completion, thoroughly clean work per resilient flooring manufacturer's recommendations. Use of solvents, wet mopping, or washing is prohibited.
- B. Defective and Damaged Work: Replace with acceptable Work at no additional cost to Owner.

### 3.5 PROTECTION

- A. General: Protect Work from traffic during construction period so Work will be without indication of use or damage at time of Substantial Completion.

END OF SECTION 096519

**SECTION 096813 – CARPET TILE**

## PART 1 - GENERAL

## 1.1 SUMMARY

- A. Furnish labor, materials, tools, equipment, and services for Carpet Tile (CPTT) in accordance with provisions of the Contract Documents.
- B. Completely coordinate with work of other trades.

## 1.2 QUALITY ASSURANCE

- A. Manufacturer Qualifications:
  - 1. Carpet manufacturer shall have no less than ten (10) years of production experience with carpet similar to type specified in this document; and whose published product literature clearly indicates compliance of products with requirements of this section.
- B. Contractor Qualifications:
  - 1. Firm with not less than five (5) years of successful carpeting experience similar to work of this section and recommended and approved by the carpet manufacturer. Upon request, submit letter from carpet manufacturer stating certification qualifications and acceptance.
- C. Installer Qualifications:
  - 1. Mill trained, skilled mechanics supervised by experienced superintendent with 50,000 yards experience.
- D. Single Source Responsibility:
  - 1. Provide product material by a single manufacturer for each carpet type specified.
- E. Carpet and Rug Institute:
  - 1. CRI-104 Standard for Installation of Commercial Carpet.
  - 2. CRI Green Label program.

## 1.3 SUBMITTALS

- A. Samples:
  - 1. Three samples 12 IN square of each material and color specified in Drawing I-001 Interior Finish Schedule.
- B. Contract Closeout Information:
  - 1. Warranty.
  - 2. Maintenance data:
    - a. See Section 01 78 23.

## 1.4 WARRANTY

- A. Written warranty for replacement of damaged or defective carpet or carpet stained by adhesives for a period of two (2) years.
- B. Written warranty that material will not significantly degrade for a period of fifteen (15) years due to the following:
  - 1. Exposure to normal light shall not affect colorfastness as measured by AATCC 16E.

2. Exposure to normal atmospheric contaminants.
  3. Excessive wear resulting in reduction of pile height by more than 15 percent in any area or pulling out of nap.
  4. Delamination from face structure and shrinkage or stretching affecting performance of face or backing structure or causing tile to curl or dome.
  5. Edge ravel.
- C. Warranty to include removal, replacement, and disposal of defective carpet.

## PART 2 - PRODUCTS

### 2.1 ACCEPTABLE MANUFACTURERS

- A. Carpet Tile : As indicated on Interior Finish Schedule. Data sheets at the end of this spec section.
1. Basis of Design:
    - a. 18"x36" tile by Shaw Contract
    - b. Style: Stipple Tile
    - c. Model: 5T116
    - d. Color: Slate 13585

### 2.2 MATERIALS

- A. Carpet Tile:
1. First quality, no seconds or imperfections.
  2. Deliver with mill register numbers attached.
  3. Comply with applicable state and local codes.
  4. Antimicrobial;
    - a. Broad spectrum efficacy against bacteria and fungus for the life of the product.
  5. Carpet installed in the building interior shall comply with the testing and product requirements of the California Department of Public Health Standard Method for the Testing and Evaluation of Volatile Organic Chemical Emissions From Indoor Sources Using Environmental Chambers version 1.1 (CDPH/EHLB Standard Method v1.1), modeled using the standard office building protocol parameters and certified as compliant by an independent third party.
- B. Carpet Edging Strips and Carpet Base:
1. Thickness to match carpet.
  2. Color to match carpet tile.
- C. Adhesive:
1. Base: Adhesive tabs by Mohawk Group or approved equal.
  2. Carpet adhesive shall have VOC content of no greater than 50 g/L.
  3. Carpet adhesives shall contain no carcinogen or reproductive toxicant components present at more than 1 percent of total mass of the product as defined in the California Office of Environmental Health Hazard Assessment's (OEHHA) list entitled Chemicals Known to the State to Cause Cancer or the Reproductive Toxicity, Safe Drinking Water and Toxic Enforcement Act of 1986 (Proposition 65).

### 2.3 EXTRA MATERIAL

- A. Furnish Owner with minimum of five (5) percent additional material of each type, pattern and color for maintenance purposes.

## PART 3 - EXECUTION

## 3.1 EXAMINATION

- A. Verify suitability of substrate to accept installation.
- B. Verify concrete floor surfaces are suitable for Carpet Tile installation.
  - 1. Coordinate installation with requirements of Section 07 16 04 Concrete Floor Moisture Testing, and Section 07 16 05 Water Vapor Emission Control System.

## 3.2 PREPARATION

- A. Thoroughly clean areas to receive carpet tile, strip waxes and finishes.
- B. Thoroughly remove dust and vacuum, wet mop then seal concrete.
- C. Patching Compound :
  - 1. Fill cracks, joints, holes or uneven areas with non-crumbling latex base floor filler.
  - 2. Acceptable Product: Lev-L-Astic.
  - 3. Do not mix with water.
- D. Prior to commencement of work, test area with adhesive and carpet tile to determine open time and bond.
- E. Layout:
  - 1. Arrange joints symmetrically about centerline of rooms.
  - 2. Lay so pile and pattern of adjacent pieces match.
  - 3. Verify dimensions.

## 3.3 INSTALLATION

- A. General:
  - 1. Comply with manufacturer's instructions and recommendations for uniformity of direction, seam locations, and lay of carpet pile.
  - 2. Install carpet under open bottom obstructions and under removable flanges and furnishings, and into alcoves and closets of each space.
  - 3. Provide cut outs where required.
    - a. Conceal cut edges with protective edge guards or overlapping flanges.
  - 4. Run carpet under open-bottom items such as heating convectors.
  - 5. Install tight against walls, columns, cabinets and over recessed door closers.
  - 6. Install edge guard at openings and doors wherever carpet terminates, unless indicated otherwise.
  - 7. Make clean cuts in accordance with manufacturer's recommendation.
  - 8. Butt edges to produce tightest joint possible without distortion.
  - 9. Fill or level floors at uneven areas with leveling compound and feather minimum 4 FT- 0 IN.
  - 10. Where carpet tiles abut thicker finish flooring materials, feather leveling compound for approximately 12 IN for each 1/8 IN of rise so finished surfaces align.
  - 11. Expansion joints:
    - a. Do not bridge building expansion joints with continuous carpeting.
    - b. Provide for movement.
- B. Install in accordance with manufacturer's instructions.
  - 1. Adhesive must have recommended flash time before carpet is positioned.
  - 2. Do not mix dye lots in same area.
  - 3. Install carpet tiles with arrows pointing in same direction.

- C. Install carpet edging strips, transition strips, reducer strips, at non-carpeted floor surface.
    - 1. Install with contact adhesive.
    - 2. Score and trim narrow end of reducer strip to conform to adjacent floor finish.
  - D. Install according to Architect's directions for overall patterns and borders.
    - 1. Install carpet patterns according to drawings without deviation.
    - 2. Develop templates as required.
- 3.4 CLEAN
- A. Remove spillage of adhesive from face or seam using remover provided by manufacturer.
  - B. Remove loose threads with broadloom scissors.
  - C. Remove spots.
  - D. Completely and thoroughly vacuum using pile lifter.
  - E. Save cuts over 9 IN for Owner stock.
  - F. Advise Owner regarding care and maintenance.
- 3.5 PROTECTION
- A. Protect carpet subject to traffic with nonstaining building material paper runners or other approved material.
  - B. Protect installation from rolling traffic with sheets of hardboard or plywood.
  - C. Maintain carpet protection on each floor or area until accepted.
- 3.6 INSPECTION
- A. Inspect installation and verify work is complete and properly installed.

END OF SECTION

**SECTION 099123- INTERIOR PAINTING**

## PART 1 - GENERAL

## 1.1 SUMMARY

- A. Work Included: Interior and Exterior Painting, complete as shown on Drawings and as specified.
1. Work includes, but is not limited to, painting of following items, materials, and spaces:
    - a. Paint every interior and exterior exposed-to-view unfinished surface, except as otherwise shown on Drawings or as specified.
    - b. Paint the following exposed mechanical and electrical items to match adjacent surfaces even if the items are factory-finished:
      - 1) Wall and ceiling diffusers/registers installed in gypsum board assemblies at any location.
      - 2) Access doors at any location except when concealed above suspended ceilings.
      - 3) Flush-mounted electrical panelboards and cabinets in gypsum board assemblies at any location.
      - 4) All exposed piping, conduit, duct work and similar surfaces in Stair Enclosures and Fire Control Room (except items with factory "red" finish).
    - c. Paint semi-visible areas behind registers, grilles, diffusers, screen vents as required to "black out".
    - d. Paint auxiliary rails of smoke containment screens with high-temperature coating.
    - e. Stairs: Paint all exposed ferrous metal assemblies, concrete landings and treads, including hazard striping as required by code.
    - f. Stenciling at Smoke Partition and Fire Rated Walls: See section 092900 Gypsum Board.
  2. Do not paint the following items:
    - a. Factory-finished items specified in various Sections.
    - b. Pre-finished wall, ceiling, and floor coverings.

- c. Concrete traffic or walking decks, walks, steps, and ramps.
  - d. Code-Required Labels: Keep equipment identification and fire rating labels free of paint.
  - e. Surfaces concealed in walls and above ceilings except as specifically indicated otherwise.
  - f. Ducts, piping, conduit, and equipment concealed in walls and ceilings, unless specifically indicated otherwise.
  - g. Do not paint "Shell Areas" as shown on drawings except paint all sides of doors and frames at walls into finished areas.
  - h. Mechanical or elevator shafts not requiring periodic cleaning.
  - i. Mechanically-finished nonferrous metal, such as stainless steel, aluminum, and bronze, except exposed mechanical and electrical items.
  - j. Interior spaces specifically noted as unpainted.
3. Note: This Section includes a comprehensive listing of paint finish types. Not all paint systems included herein may be required by the Scope of Work of this Project, or the scope of some finishes may be very limited. The responsibility of the Contractor to schedule the Work so that all specified and required Painting Scope is included in the Scope of Work for the Project.
- B. Work Specified Elsewhere:
- 1. Section 050500 – Metal Fasteners.
  - 2. Section 079200 – Joint Sealants.
  - 3. Section 099113 – Exterior Painting.

## 1.2 SUBMITTALS

- A. Comply with requirements of Section 013300 – Submittal Procedures.
- B. Product Data: Submit complete list of materials proposed for use, together with manufacturer's data and specifications.
- C. Samples:
  - 1. Opaque Colors and Finishes: Submit samples, on hardboard, using materials accepted for Project, of each color and paint finish selected with texture to simulate actual conditions. Prepare three samples, 8-1/2 inches by 11 inches, with required number of paint coats clearly visible.



2. Transparent and Stained Finishes: Prepare samples on species and quality of wood to be used in the Work. Re-submit as requested until acceptable sheen, color, and texture are achieved. Label and identify each sample as to location and application.

### 1.3 QUALITY ASSURANCE

- A. Labeling: Include following on label of each container:
  1. Manufacturer's name and product name.
  2. Generic type of paint.
  3. Manufacturer's stock number.
  4. Color.
  5. Instructions for reducing, where applicable.
- B. Special Requirements of Regulatory Agencies: Use materials for Work of this Section which comply with volatile organic compound limitations and other regulations of local Air Quality Management District and other local, state, and federal agencies having jurisdiction.
- C. Project Mock-Up: As directed by the Architect, apply on actual wall surfaces where designated, samples of each and any color selected for final review.
  1. On at least 100 square feet of surface as directed, provide full-coat finish samples until required sheen, color and texture are obtained.
  2. Duplicate painted finishes of prepared samples.
  3. Simulate finished lighting conditions for review of in-place work.

### 1.4 PRODUCT HANDLING

- A. Comply with requirements of Section 016000 – Product Requirements.
- B. Delivery: Deliver material in sealed containers with labels legible and intact.
- C. Storage of Materials:
  1. Store only acceptable Project materials on Project site.
  2. Store in suitable location.
  3. Restrict storage to paint materials and related equipment.
  4. Comply with health and fire regulations.

### 1.5 PROJECT CONDITIONS

- A. Environmental Requirements:
  - 1. Comply with manufacturer's recommendations as to environmental conditions under which coatings and coating systems can be stored and applied.
  - 2. Do not apply finish in areas where dust is being generated.
- B. Protection: Cover or otherwise protect finished work of other trades and surfaces not being painted concurrently or not to be painted.

## 1.6 SCHEDULING

- A. Gypsum Board: Verify that a fully-cured skim coat has been applied to Gypsum Board specified for Level 5 finish and scheduled to receive semi-gloss or gloss paint finishes. Do not proceed until completed.

## 1.7 MAINTENANCE

- A. Extra Materials: At completion of Work, deliver to Owner extra stock of paint of one gallon of each color used of each coating material used. Tightly seal and clearly label containers.

## PART 2 - PRODUCTS

### 2.1 MANUFACTURERS

- A. Primers and Single-color Paints: Provide paint systems as manufactured by Sherwin-Williams Co. Unless otherwise specified, single source all components of a paint system from a single manufacturer, including primer/sealer/undercoat and body and finish coats to assure compatibility.
  - 1. Sherwin-Williams Co. (S/W).

### 2.2 MATERIALS

- A. General: Provide materials selected for coating system for each type of surface which are the product of single manufacturer.
- B. Thinner: As recommended by each manufacturer for his respective product.
- C. Unsuitability of Specified Products: Claims concerning unsuitability of any materials specified will not be entertained, unless such claim is made in writing to the Architect before Work is started.

### 2.3 COLORS

- A. Color and Sheen: Colors are scheduled on Drawings (or as selected by Architect if not scheduled on Drawings) based on standard color chips provided by one or more of the listed manufacturers.
- B. Mixing: Deliver paints and stains ready mixed to Project site.

#### 2.4 MILDEW RESISTANCE

- A. General: Add fungicidal agent to paint per manufacturer's recommendations. Add agent to paint at factory. Clearly indicate on labels that paint is mildew resistant.

### PART 3 - EXECUTION

#### 3.1 EXAMINATION

- A. Verification of Conditions: Examine surfaces scheduled to receive paint and finishes for conditions that might adversely affect execution, permanence, or quality of work and which cannot be put into acceptable condition through preparatory work. Proceed with preparation or coating application only when conditions are satisfactory.
- B. Review all questions regarding the scope of painting with Owner prior to proceeding with Work.

#### 3.2 SURFACE PREPARATION

- A. General: Remove scale, dirt, dust, grit, rust, wax, grease, efflorescence, loose material, and other foreign matter detrimental to proper adhesion of paint.
- B. Gypsum Board:
  - 1. Narrow, Shallow Cracks and Small Holes: Fill with spackling compound.
  - 2. Deep, Wide Cracks and Deep Holes: Rake out, dampen with clear water, and fill with thin layers of gypsum board joint compound.
  - 3. Curing: Allow to dry.
  - 4. Sanding: Sand smooth after drying; do not raise nap of paper on gypsum board.
- C. Metals:
  - 1. Chipped or Abraded Areas in Shop Coatings: Touch-up using appropriate primer.
  - 2. Galvanized Surfaces: Apply a wash coat made by dissolving 8 ounces copper acetate or copper sulfate in one gallon of water; apply with brush.
  - 3. Stainless Steel: Scarify surfaces before applying prime coat.

- D. Wood:
1. General: If required, sandpaper surfaces smooth before applying primer. Thoroughly clean knots; apply thin coat of knot sealer over surfaces shown to receive opaque finish.
  2. Back Priming: Back prime surfaces installed against cementitious surfaces; give particular attention to sealing cross-grained surfaces.
  3. Puttying:
    - a. General: Fill nail holes, cracks, and other depressions flush with putty after prime coat application. Allow putty to dry; sandpaper smooth before applying body coat.
    - b. For Opaque Finish: Linseed oil type putty.
- E. Protection:
1. General: Properly protect floors and other adjacent work by drop cloths or other suitable coverings. In areas scheduled for painting, maintain wrappings and factory-applied protection provided by other trades.
  2. Hardware and Other Obstructions: Remove or protect factory finished items such as hardware, plates, lighting fixtures, grilles, and similar items placed prior to painting. Reposition or remove protection upon completion of each space. Equipment adjacent to surfaces requiring paint disconnected, moved, reset, and reconnected by respective trades.
  3. Fire Precautions: At end of each work day, place in metal containers or remove from premises, solvent soaked cloths, waste, and other materials which constitute a fire hazard.
- F. Moisture Content: Do not apply initial coating until moisture content of surface is within limitations recommended by paint manufacturer.

### 3.3 APPLICATION

- A. General: Apply paint per manufacturer's instructions and as specified. Thoroughly stir paint and keep at uniform consistency during application. Apply paint evenly, free from drops, ridges, waves, laps, and brush marks; finished surface uniform in sheen, color, and texture. Apply succeeding coats to unscarred and completely integral base coats; slightly vary color of undercoats to distinguish them from preceding coat. Allow sufficient time between coats to assure proper drying. Sandpaper smooth interior finishes between coats.
- B. Prime Coat: Do not thin primers in excess of manufacturer's printed directions. Apply by brush, unless otherwise specified, within 8 hours after cleaning.

- C. Body and Finish Coats: Do not thin; apply by brush, roller or spray.
- D. Drying Time: Comply with recommendations of product manufacturer for drying time between succeeding coats.
- E. Moldings and Ornaments: Leave clean and true to details with no undue amount of paint in corners and depressions.
- F. Edges of Paint: Where adjoining other materials or colors, make clean and sharp with no overlapping.
- G. Refinishing: Refinish entire wall where portion of finish is deemed not acceptable.
- H. Precaution: Do not paint over fusible links, UL labels, or sprinkler heads.
- I. Exposed Plumbing and Mechanical Items: Finish items without factory finish such as conduits, pipes, access panels, and items of similar nature to match adjacent wall and ceiling surfaces, unless otherwise directed.

### 3.4 CLEANING

- A. General: Touch up and restore finish where damaged. Remove spilled, splashed, or spattered paint from surfaces. Do not mar surface finish of item being cleaned.
- B. Storage Space: Leave clean and in condition required for equivalent spaces in Project.

### 3.5 PAINT SYSTEMS

- A. Schedule: Only major areas are scheduled. Treat miscellaneous and similar items and areas within room or space with similar system.
- B. Number of Coats: Where number of coats are specified, it is only as a minimum requirement. Apply additional coats, at no additional cost to Owner, if necessary to completely hide base material, produce uniform color, and provide satisfactory finish result.
- C. Thickness of Coats: For each paint system product, provide the manufacturer's recommended mil-thickness for each applied coat.
- D. Systems Specifications: These specifications are a guide and are meant to establish procedure and quality. Confer with Architect to determine exact finish desired.
- E. Acceptance of Final Colors: Do not apply final coats of paint for either exterior and interior systems until colors have been reviewed and accepted by the Architect.

3.6 INTERIOR PAINT SYSTEMS (Systems are based on products by S-W; other manufacturers listed in Part Two may be used)

A. Interior Gypsum Board – Flat:

1. General: Provide as follows unless otherwise scheduled on Drawings or noted as follows in this Section.
2. Flat Finish — Low Odor Zero VOC System
3. Primer: ProMar 200 Zero VOC Interior Latex Primer, B28W2600, 0 g/L VOC
4. 1st coat: ProMar 200 Zero VOC Flat, B30-2600 series, 0 g/L VOC
5. 2nd coat: ProMar 200 Zero VOC Flat, B30-2600 series, 0 g/L VOC

B. Interior Gypsum Board – Eggshell/Satin:

1. General: Provide as follows unless otherwise scheduled on Drawings or noted as follows in this Section.
2. Primer: ProMar 200 Zero VOC Interior Latex Primer, B28W2600 0 g/L VOC
3. 1st coat: ProMar 200 Zero VOC Eg-Shel B26-2600 series, 0 g/L VOC
4. 2nd coat: ProMar 200 Zero VOC Eg-Shel B26-2600 series, 0 g/L VOC

C. Interior Gypsum Board – Semi-gloss:

1. General: Provide at stairs, service areas and where scheduled.
2. Primer: ProMar 200 Zero VOC Interior Latex Primer, B28W2600, 0 g/L VOC
3. 1st coat: ProMar 200 Zero VOC Semi-Gloss B31-2600 series, 0 g/L VOC
4. 2nd coat: ProMar 200 Zero VOC Semi-Gloss B31-2600 series, 0 g/L VOC

D. Interior Gypsum Board – Epoxy Coatings:

1. General: Provide at Restroom and other gypsum surfaces as scheduled on Drawings and required by the the governing Health Codes:
2. Eg-Shel Finish
  - a. Primer: ProMar 200 Zero VOC Primer, B28W2600, 0 g/L VOC
  - b. 1st coat: Pro Industrial Pre-Catalyzed Water-Based Epoxy Eg-Shel, K45 series, <150 g/L VOC
  - c. 2nd coat: Pro Industrial Pre-Catalyzed Water-Based Epoxy Eg-Shel, K45 series, <150 g/L VOC
3. Semi-Gloss Finish (typical, unless noted otherwise)
  - a. Primer: ProMar 200 Zero VOC Primer, B28W2600, 0 g/L VOC
  - b. 1st coat: Pro Industrial Pre-Catalyzed Water-Based Epoxy Semi-Gloss, K46 series, <150 g/L VOC
  - c. 2nd coat: Pro Industrial Pre-Catalyzed Water-Based Epoxy Semi-Gloss, K46 series, <150 g/L VOC
4. Gloss Finish
  - a. Primer: ProMar 200 Zero VOC Primer, B28W2600, 0 g/L VOC
  - b. 1st coat: Pro Industrial Zero VOC Water-Based Epoxy Gloss, B73-300 series, 0 g/L VOC

- c. 2nd coat: Pro Industrial Zero VOC Water-Based Epoxy Gloss, B73-300 series, 0 g/L VOC

E. Interior Ferrous Metal:

1. General: Shop and field-applied paint finishes for the Work of Section 050500 – Metal Fabrications, is included in the Scope of Work for those Sections.
2. For other exposed-to-view ferrous metal items, including items specified in DIVISION 23 – Mechanical; and DIVISION 26 – Electrical, provide the finishes as follow:
3. Bare Metal Items; High Performance Coating System: Mechanical and Electrical Piping, Conduits, Ductwork, Supports, Hangers, Machinery and Similar Items:
  - a. Eg-Shel or Gloss Finish (Verify with Architect for each room / area prior to painting)
  - b. Primer: Pro Industrial Pro-Cryl Universal Primer, B66-310 series, <100 g/L VOC
  - c. 1st coat: Pro Industrial Zero VOC Water-Based Epoxy Eg-Shel, B73-360 series or Gloss, B73-300 series, 0 g/L VOC
  - d. 2nd coat: Pro Industrial Zero VOC Water-Based Epoxy Eg-Shel, B73-360 series or Gloss, B73-300 series, 0 g/L VOC
4. Shop Primed or painted (by others) Items; Semi-Gloss finish:
  - a. Primer: Pro Industrial Pro-Cryl Universal Primer, B66-310 series, <100 g/L VOC
  - b. 1st coat: Pro Industrial Zero VOC Acrylic Semi-Gloss, B66-650 series, 0 g/L VOC
  - c. 2nd coat: Pro Industrial Zero VOC Acrylic Semi-Gloss, B66-650 series, 0 g/L VOC
5. Shop Galvanized Items:
  - a. Galvanizing repair provided in Section 050500 – Metal Fabrications.
  - b. Galvanized Metal Decking & Ferrous Decking — Including Bar Joists
    - i. Flat, Eg-Shel, or Semi-Gloss Finish
    - ii. Primer: Pro Industrial Pro-Cryl Universal Primer, B66-310 series, <100 g/L VOC
    - iii. 1st coat: Low VOC Waterborne Acrylic Dryfall, Flat B42W81, Eg-Shel B42W82, Semi-Gloss, B42W83, All sheens <50 g/L VOC
    - iv. 2nd coat: Low VOC Waterborne Acrylic Dryfall, Flat B42W81, Eg-Shel B42W82, Semi-Gloss, B42W83, All sheens <50 g/L VOC
  - c. Galvanized Metal Decking & Ferrous Decking — Including Bar Joists – High Performance System

- i. Primer: Pro Industrial Pro-Cryl Universal Primer, B66-310 series, <100 g/L VOC
  - ii. 1st coat: Pro Industrial Multi-Surface Acrylic Eg-Shel, B66-560 series, <150 g/L VOC
  - iii. 2nd coat: Pro Industrial Multi-Surface Acrylic Eg-Shel, B66-560 series, <150 g/L VOC
  
- F. Interior Aluminum and Copper:
  1. Refer to Section 076200 – Flashing and Sheet Metal for shop and field-applied paint finishes specified in those Sections.
  2. Mechanical and Electrical Items:
    - a. Pretreatment: Metal Pretreatment.
    - b. 1st Coat: Aluminum Primer. Provide additional general purpose sealer coat when recommended by paint manufacturer.
    - c. 2nd Coat: Acrylic Paint, Semi-Gloss.
    - d. 3rd Coat: Acrylic Paint, Semi-Gloss.
  
- G. Interior Wood:
  1. General: Transparent Finishes are specified and provided in Section 064123 Interior Architectural Woodwork
  2. Semi-Gloss Finish — Low Odor Zero VOC System
  3. Primer: ProMar 200 Zero VOC Primer, B28W2600, 0 g/L VOC
  4. 1st coat: Pro Industrial Zero VOC Acrylic Semi-Gloss, B66-650 series, 0 g/L VOC
  5. 2nd coat: Pro Industrial Zero VOC Acrylic Semi-Gloss, B66-650 series, 0 g/L VOC
  
- H. Interior Mechanical Insulation; Finish Varies:
  1. Provide finish materials recommended in writing by the mechanical insulation manufacturer for their products in exterior locations. Adapt the following as required.
    - a. 1st Coat: General Purpose PVA Sealer, or as recommended by the insulation manufacturer.
    - b. 2nd Coat: Match adjacent finish system.
  
- I. Miscellaneous Interior Painting Systems:
  1. Ductwork at Grilles and Diffusers:
    - a. Apply interior surfaces of ductwork partially visible through grilles and diffusers.
    - b. 1st Coat: Galvanized Metal Primer.



- c. 2nd Coat: Acrylic Paint, Matte Black.
  - d. 3rd Coat: Acrylic Paint, Matte Black.
2. Exposed Insulated Pipes and Ductwork:
- a. 1st Coat: 1 coat General Purpose PVA sealer. Omit sealer where glass fabric jackets are used.
  - b. 2nd Coat: Acrylic Paint, match adjacent finish.
  - c. 3rd Coat: Acrylic Paint, match adjacent finish.
3. Exposed Non-Insulated Pipes and Ductwork: Including conduit.
- a. Cast-Iron Pipe:
    - 1) Pre-treatment: Conform with the requirements of Section 050500 – Metal Fabrications.
    - 2) 1st Coat: Ferrous Metal Primer.
    - 3) 2nd Coat: Acrylic Paint, match adjacent finish.
    - 4) 3rd Coat: Acrylic Paint, match adjacent finish.
  - b. Other Pipes, Conduit, and Ductwork:
    - 1) Pre-treatment: Conform with the requirements of Section 050500 – Metal Fabrications.
    - 2) 1st Coat: As specified for ferrous and non-ferrous metals as applicable.
    - 3) 2nd Coat: Acrylic Paint, match adjacent finish.
    - 4) 3rd Coat: Acrylic Paint, match adjacent finish.
- J. Miscellaneous Interior Painting Systems:
- 1. Factory Finished Equipment: Satisfactorily refinish surfaces damaged before, during, or after installation as directed; use 128 semi-gloss enamel.
  - 2. Plywood Equipment Backing:
    - a. General: Telephone, Data and Electric Closets.
    - b. 1st Coat: Latex Enamel Undercoater.
    - c. 2nd Coat: Acrylic Paint; match adjacent finish.

d. 3rd Coat: Acrylic Paint; match adjacent finish.

K. Pipe Identification:

1. General: Per ANSI A13.1; buried pipe, electrical conduit, and pipe in concealed spaces such as furred spaces and shafts not included.
2. Color Scheme: ANSI Z53.1 in combination with legend and flow markers; continuous total length coverage. Safety colors as specified under applicable Mechanical Section.
3. Legend: Stencil letters of colors, type, and sizes per ANSI A13.1. Tags for identification of pipes less than 3/4-inch overall outside diameter, including valves and fittings; provided under applicable mechanical Section.
4. Flow Markers: Provide each type with appropriate size arrows to indicate flow direction in pipe; same color as legend.
5. Visibility: Locate legend and flowmarkers for easy visibility from operating floor; space not over 20 feet with at least one per room.

3.8 CLEANING:

- A. Comply with provisions of Section 017900 – Cleaning.
- B. Remove paint spots, oil, and stains from adjacent surfaces upon completion of Work; leave Work clean.

END OF SECTION

**SECTION 102600 – WALL AND DOOR PROTECTION**

## PART 1 - GENERAL

## 1.1 SUMMARY

A. Work Included: Provide and install wall protection, wall corner guards and other finish protection products, complete, as shown on Drawings and as specified, including:

1. Surface-Mounted Corner Guards and Partition End Guards.
2. Protective Wall Covering Wainscot
3. Crash Rails

B. Work Specified Elsewhere:

1. Section 081113 – Hollow Metal Doors and Frames.
2. Section 084113 – Aluminum Entrances and Storefronts.
3. Section 081416 – Flush Wood Doors.
4. Section 079200 – Joint Sealants.
5. Section 087100 – Door Hardware
6. Section 092216 – Non-Structural Metal Framing.

## 1.2 SUBMITTALS

A. Comply with provisions of Section 013300 – Submittal Procedures.

B. Product Data: Manufacturer's catalog cuts, standard color charts, and data sheets; including installation details and instructions, for each item specified.

C. Samples:

1. Crash Rails: 12-inch-long piece of each type specified, including color.
2. Corridor Handrail: 12-inch-long piece of each specified type, including mounting bracket and specified finish.
3. Partition End and Corner Guards: 12-inch-long piece of each type specified, including color.
4. Wall protection and Door Protection: 12-inch-square piece of each specified type, including corner and specified color.

### 1.3 PRODUCT HANDLING

- A. Delivery and Storage: Deliver and store items and related fasteners in manufacturer's original packaging, identified with manufacturer's name and type of product, and size. Store materials indoors, protected from moisture and other sources of damage.

## PART 2 - PRODUCTS

### 2.1 MANUFACTURER

- A. General: Provide vinyl/acrovyn wall and corner protection single-sourced from one manufacturer to assure color matching.
- B. Manufacturer: Construction Specialties, Inc., or Inpro Corporation.
  - a. Basis-of-Design: Construction Specialties, Inc.,
- C. Fire Hazard Classification: Flame spread of 25 or less when tested per ASTM E84.

### 2.2 CORNER GUARDS

- A. Type: C/S Acrovyn 4000 Corner Guards – SSM-20AN with continuous aluminum retainer.
  - 1. Size: 2-inch by 2-inch by 4 feet high. Provide angled corner guards at all angled corners.
  - 2. Mounting Style: Surface-mounted with aluminum retainer.
  - 3. Color: As selected by Architect from manufacturer's full range.
  - 4. Mounting Height: From top of base.
  - 5. Locations: All Outside Wall Corner Locations.

### 2.3 PROTECTIVE WALL COVERING WAINSCOT

- A. Type: Sheet plastic wall protection by C/S acrovyn. Typical where shown on Drawings.
  - 1. Size: 0.06" thick Acrovyn 4000 panels by sizes shown on Drawings.
  - 2. Mounting Style: Surface-mounted.
  - 3. Color: As scheduled on Drawings.

4. Mounting Height: From finished floor to 4 feet above base unless noted otherwise. Align top of wall protection with top of corner guards where occurs.
1. Locations: As shown on Drawings.

## 2.4 PARTITION END PROTECTION

- A. Manufacturer: Acrovyn by Construction Specialties, Inc. (C/S); IPC Door and Wall Protection by InPro Corporation (IPC).C/S Acrovyn specified as basis-of-design.
- B. Type: Composite assembly consisting of two Acrovyn SSM-20AN corner guards and partition-end infill panel of adhesive-applied .040-inch-thick Acrovyn sheet.
  1. Size: Verify partition width; 2-inch return at each wall face.
  2. Mounting Style: Surface-mounted.
  3. Color: As scheduled on Drawings.
  4. Mounting Height: From finish floor to 4 feet above base.
  5. Provide manufacturer's coordinated top and bottom caps.
  1. Locations: **At all wall end partitions, typical.**

## 2.5 MISCELLANEOUS MATERIALS

- A. Fasteners: Manufacturer's standard, removable, corrosion-resistant fasteners of size and length suitable for the conditions of installation.
- B. Adhesive: As recommended by manufacturer for setting material.
- C. Backing Plates: As specified in Section 092216 – Non-Structural Metal Framing and as shown on Drawings.
- D. Products shall be furnished as a complete packaged system, including appropriate Adhesive, Primer, Caulking and Trims per manufactures recommendations.

## PART 3 - EXECUTION

### 3.1 EXAMINATION

- A. Verification of Conditions: After application of wall base and finish painting of walls is complete, examine areas and conditions under which items are to be

installed. If unsatisfactory conditions exist, do not proceed with the Work until such conditions have been corrected.

### 3.2 PREPARATION

- A. Cleaning: Prior to application, clean side of units that will be in contact with wall surface.

### 3.3 INSTALLATION

- A.** Install the work of this section in strict accordance with the manufacturer's recommendations, using only approved mounting hardware and locating all components firmly into position, level and plumb.
- B.** Temperature at the time of installation must be between 65°-75°F (18°-24°C) and be maintained for at least 48 hours after the installation.
- C.** Adjust installed end caps as necessary to ensure tight seams.

### 3.4 ADJUSTING AND CLEANING

- A. Cleaning: Prior to time of final acceptance, strip units of protective coverings, and clean in accordance with manufacturer's instructions.
- B. Defective Materials: Remove and replace any defective, misaligned, or damaged units, at no additional cost to Owner.

END OF SECTION

**SECTION 211000 - WATER-BASED FIRE-SUPPRESSION SYSTEMS**

**PART 1 - GENERAL**

**1.1 RELATED DOCUMENTS**

- A. Drawings and general provisions of the Contract, including General and Supplementary Conditions and Division 01 Specification Sections, apply to this Section.

**1.2 SUMMARY**

- A. This Section includes the following fire-suppression piping inside the building:
  - 1. Semiautomatic wet-type, Class I standpipe systems.
  - 2. Wet-pipe sprinkler systems.
  - 3. Description: Remodel of an existing x-ray room into a two-bay patient holding room. All sprinklers and piping to be removed and new sprinklers and piping to be installed to NFPA 13 standards after ductwork is installed. Flat plate concealed pendent sprinklers to be used.
- B. Related Sections include the following:
  - 1. Division 10 Section "Fire Extinguisher Cabinets" and "Fire Extinguishers" for cabinets and fire extinguishers.
  - 2. Division 22 Section "Facility Water Distribution Piping" for piping outside the building.
  - 3. Division 28 Section "Fire Detection and Alarm" for alarm devices not specified in this Section.
- C. All black steel sprinkler pipe shall have a wall thickness less than or equal to schedule 40 and greater than schedule 10.
  - 1. Exception: Pipe with a nominal pipe size of 6 inches and greater may be schedule 10.

**D. Summary Table:**

<b>Item</b>	<b>Summary</b>	<b>ref</b>
Underground service entrance piping	Existing to remain.	2.2, 3.4.E, 3.6B, 3.8.D
Interior pipe type	Mains: Schedule 40 Branchlines: Threadable thinwall or schedule 40	2.3, 2.
Sprinkler Finish	Flat Plate Concealed, except uprights and storage, coordinate color of cover plate with architect and ceiling color.	3.11, 3.12
Extended Coverage	Not Allowed	3.11.A
Center of Tile	Required, Center thirds are acceptable for rectangular tiles	
Flexible Sprinkler Drops	Designers preference	2.9
FM Global	No	
Calculations	Required, use reduced flow data	1.5.D, 3.1
Alarm Device	Horn/Strobe	2.19.B

FDC	Existing to remain	
Special Items	All sprinklers and piping to be removed and new sprinklers and piping to be installed to NFPA 13 standards after ductwork is installed.	
Seismic		1.5.E
Coordination	All sprinkler piping exposed to view shall be coordinated with the architect prior to final design acceptance.	

1.3 DEFINITIONS

- A. CPVC: Chlorinated polyvinyl chloride plastic.
- B. CR: Chlorosulfonated polyethylene synthetic rubber.
- C. High-Pressure Piping System: Fire-suppression piping system designed to operate at working pressure higher than standard 175 psig.
- D. PE: Polyethylene plastic.
- E. Underground Service-Entrance Piping: Underground service piping below the building.

1.4 SYSTEM DESCRIPTIONS

- A. Manual Wet-Type, Class I Standpipe System: Includes NPS 2-1/2 hose connections. Has a small water supply to maintain water in standpipes. Piping is wet, but water must be pumped into standpipes to satisfy demand.
- B. Wet-Pipe Sprinkler System: Automatic sprinklers are attached to piping containing water and that is connected to water supply. Water discharges immediately from sprinklers when they are opened. Sprinklers open when heat melts fusible link or destroys frangible device. Hose connections are included if indicated.

1.5 PERFORMANCE REQUIREMENTS

- A. Standard Piping System Component Working Pressure: Listed for at least 175 psig.
- B. High-Pressure Piping System Component Working Pressure: Listed for 250 psig minimum 300 psig.
- C. Fire-suppression standpipe system design shall be approved by authorities having jurisdiction.
  - 1. Minimum residual pressure at each hose-connection outlet is the following:
    - a. NPS 1-1/2 Hose Connections: 65 psig.
    - b. NPS 2-1/2 Hose Connections: 100 psig.
  - 2. Unless otherwise indicated, the following is maximum residual pressure at required flow at each hose-connection outlet:



- a. NPS 1-1/2 Hose Connections: 100 psig.
  - b. NPS 2-1/2 Hose Connections: 175 psig.
- D. Design sprinkler piping according to the following and obtain approval from engineer, prior to submitting to other authorities having jurisdiction:
1. Design sprinkler system with the following 10% reduced flow data:  
  
Flow data available at PROVIDED BY CONTRACTOR  
  
Static – PROVIDED BY CONTRACTOR  
  
Residual – PROVIDED BY CONTRACTOR  
  
Date of Test – PROVIDED BY CONTRACTOR
  2. Margin of Safety for Available Water Flow and Pressure: 10 percent, including losses through water-service piping, valves, and backflow preventers.
  3. Sprinkler Occupancy Hazard Classifications:
    - a. Automobile Parking Areas: Ordinary Hazard, Group 1.
    - b. Building Service Areas: Ordinary Hazard, Group 1.
    - c. Electrical Equipment Rooms: Ordinary Hazard, Group 1.
    - d. General Storage Areas: Ordinary Hazard, Group 1.
    - e. Laundries: Ordinary Hazard, Group 1.
    - f. Libraries, Except Stack Areas: Light Hazard.
    - g. Library Stack Areas: Ordinary Hazard, Group 2.
    - h. Mechanical Equipment Rooms: Ordinary Hazard, Group 1.
    - i. Office and Public Areas: Light Hazard.
    - j. Residential Living Areas: Light Hazard.
    - k. Restaurant Service Areas: Ordinary Hazard, Group 1.
  4. Minimum Density for Automatic-Sprinkler Piping Design:
    - a. Light-Hazard Occupancy: 0.10 gpm over 1500-sq. ft. area.
    - b. Ordinary-Hazard, Group 1 Occupancy: 0.15 gpm over 1500-sq. ft. area.
    - c. Ordinary-Hazard, Group 2 Occupancy: 0.20 gpm over 1500-sq. ft. area.
    - d. Extra-Hazard, Group 1 Occupancy: 0.30 gpm over 2500-sq. ft. area.
    - e. Extra-Hazard, Group 2 Occupancy: 0.40 gpm over 2500-sq. ft. area.
    - f. Special Occupancy Hazard: As determined by authorities having jurisdiction.
  5. Minimum Density for Deluge-Sprinkler Piping Design:
    - a. Ordinary-Hazard, Group 1 Occupancy: 0.15 gpm over entire area.
    - b. Ordinary-Hazard, Group 2 Occupancy: 0.20 gpm over entire area.
    - c. Extra-Hazard, Group 1 Occupancy: 0.30 gpm over entire area.
    - d. Extra-Hazard, Group 2 Occupancy: 0.40 gpm over entire area.
    - e. Special Occupancy Hazard: As determined by authorities having jurisdiction.
  6. Maximum Protection Area per Sprinkler: Per UL listing.
  7. Maximum Protection Area per Sprinkler:
    - a. Office Spaces: 225 sq. ft..

- b. Storage Areas: 130 sq. ft..
  - c. Mechanical Equipment Rooms: 130 sq. ft..
  - d. Electrical Equipment Rooms: 130 sq. ft..
  - e. Other Areas: According to NFPA 13 recommendations, unless otherwise indicated.
8. Total Combined Hose-Stream Demand Requirement: According to NFPA 13, unless otherwise indicated:
- a. Light-Hazard Occupancies: 100 gpm for 30 minutes.
  - b. Ordinary-Hazard Occupancies: 250 gpm for 60 to 90 minutes.
  - c. Extra-Hazard Occupancies: 500 gpm for 90 to 120 minutes.
9. Sprinklers are to be installed throughout the premises, as required by NFPA 13.
- E. Seismic Performance: Fire-suppression piping shall be capable of withstanding the effects of earthquake motions determined according to NFPA 13.

## 1.6 SUBMITTALS

- A. Product Data: For the following:
- 1. Piping materials, including dielectric fittings, flexible connections, and sprinkler specialty fittings.
  - 2. Pipe hangers and supports, including seismic restraints.
  - 3. Valves, including listed fire-protection valves, unlisted general-duty valves, and specialty valves and trim.
  - 4. Air compressors, including electrical data.
  - 5. Sprinklers, escutcheons, and guards. Include sprinkler flow characteristics, mounting, finish, and other pertinent data.
  - 6. Hose connections, including size, type, and finish.
  - 7. Fire department connections, including type; number, size, and arrangement of inlets; caps and chains; size and direction of outlet; escutcheon and marking; and finish.
  - 8. Alarm devices, including electrical data.
- B. Shop Drawings: Diagram power, signal, and control wiring.
- C. Fire-hydrant flow test report.
- D. Seismic Calculations.
- E. Approved Sprinkler Piping Drawings: Working plans, prepared according to NFPA 13, that have been approved by authorities having jurisdiction, including hydraulic calculations, if applicable. Drawings are to be approved by Engineer prior to submission to State Fire Marshal.
- F. Field Test Reports and Certificates: Indicate and interpret test results for compliance with performance requirements and as described in NFPA 13 and NFPA 14. Include "Contractor's Material and Test Certificate for Aboveground Piping" and "Contractor's Material and Test Certificate for Underground Piping."
- G. Welding certificates.
- H. Field quality-control test reports.

- I. Operation and Maintenance Data: For standpipe and sprinkler specialties to include in emergency, operation, and maintenance manuals.

## 1.7 QUALITY ASSURANCE

### A. Installer Qualifications:

1. An experienced installer who has designed and installed fire-suppression piping similar to that indicated for this Project and obtained design approval and inspection approval from authorities having jurisdiction. The Engineer requires evidence to support the ability of the contractor to perform work in the scope and volume as specified. A contractor, who cannot show such experience, may be found not suitable to perform the work. The following are the approved contractors for this project:

#### a. PRE-APPROVED CONTRACTORS LIST

- 1) A&D Fire
- 2) Alta Fire
- 3) Certified Fire
- 4) Chaparral Fire (A-1 National)
- 5) Delta Fire
- 6) Kimco Fire
- 7) Preferred Fire Protection
- 8) Quality Fire Protection
- 9) FireTrol
- 10) FireFly Fire Protection
- 11) Simplex-Grinnell
- 12) State Fire DC Specialties
- 13) The Safety Team
- 14) Western Automatic
- 15) Or prior approved equal

- b. A contractor not listed in the "PRE-APPROVED CONTRACTORS LIST" must receive prior approval from the engineer to bid this project.

- B. Installer's responsibilities include designing, fabricating, and installing fire-suppression systems and providing professional engineering services needed to assume engineering responsibility. Base calculations on results of fire-hydrant flow test.

1. Engineering Responsibility: Preparation of working plans, calculations, and field test reports by a qualified professional engineer or NICET Level III technician.

- C. Welding: Qualify processes and operators according to ASME Boiler and Pressure Vessel Code: Section IX.

- D. NFPA Standards: Fire-suppression-system equipment, specialties, accessories, installation, and testing shall comply with the following:

1. NFPA 13, "Installation of Sprinkler Systems."
2. NFPA 13R, "Installation of Sprinkler Systems in Residential Occupancies up to and Including Four Stories in Height."
3. NFPA 14, "Installation of Standpipe, Private Hydrant, and Hose Systems."
4. NFPA 24, "Installation of Private Fire Service Mains and Their Appurtenances."

- E. International Conference of Building Code Officials codes and standards complying with the following:

1. IBC-2018, "International Building Code."
2. IFC-2018, "International Fire Code."

F. Utah Amendments

1. Title 15A

1.8 COORDINATION

- A. Coordinate layout and installation of sprinklers with other construction that penetrates ceilings, including light fixtures, HVAC equipment, and partition assemblies.

1.9 EXTRA MATERIALS

- A. Furnish extra materials described below that match products installed and that are packaged with protective covering for storage and identified with labels describing contents.

1. Sprinkler Cabinets: Finished, wall-mounting, steel cabinet with hinged cover, with space for minimum of six spare sprinklers plus sprinkler wrench. Include number of sprinklers required by NFPA 13 and sprinkler wrench. Include a minimum of six spare sprinklers for each type and rating of sprinkler head in the project per CMS and CDC requirement. The minimum number of sprinklers per NFPA 13 shall be required regardless of how many head types there are. There is no upper limit of spare sprinklers. Include separate cabinet with sprinklers and wrench for each type of sprinkler on Project.

1.10 General Engineering Quality

- A. Unless noted otherwise the following applies:

1. The maximum water velocity shall not exceed 32-fps.
2. Submit the calculations using the reduced flow data.
3. When calculating flexible drops, the contractor shall use the maximum number of bends for the associated length. The value is to be taken from the UL tests (unless the material is only FM approved).
4. In the event of multiple (3) submittal rejections (including revise and resubmit) a meeting shall be held at the engineer's office at the engineer time of choosing and the designer, fire sprinkler contractor, and general contractor shall be physically in attendance to discuss the required modifications to the design.

1.11 Contract Completion

- A. Incomplete and Unacceptable work:

1. If additional site visits or design work is required by the Engineer or Architect because of the use of incomplete or unacceptable work by the Contractor, then the Contractor shall reimburse the Engineer and Architect for all additional time and expenses involved.

## PART 2 - PRODUCTS

### 2.1 MANUFACTURERS

- A. In other Part 2 articles where titles below introduce lists, the following requirements apply to product selection:
1. Manufacturers: Subject to compliance with requirements, provide products by one of the manufacturers specified.

### 2.2 DUCTILE-IRON PIPE AND FITTINGS

- A. Mechanical-Joint, Ductile-Iron Pipe: AWWA C151, with mechanical-joint bell end and plain end.
1. Mechanical-Joint, Ductile-Iron Fittings: AWWA C110, Class 53, ductile- or gray-iron standard pattern or AWWA C153, ductile-iron compact pattern.
  2. Glands, Gaskets, and Bolts: AWWA C111, ductile- or gray-iron gland, rubber gasket, and steel bolts and nuts.
- B. Push-on-Joint, Ductile-Iron Pipe: AWWA C151, with push-on-joint bell end and plain end.
1. Push-on-Joint, Ductile-Iron Fittings: AWWA C110, ductile- or gray-iron standard pattern or AWWA C153, ductile-iron compact pattern.
  2. Gaskets: AWWA C111, rubber.

### 2.3 C-900 TUBE AND FITTINGS

- A. PVC, AWWA Pipe: AWWA C900, Class 150, with bell end with gasket and spigot end.
1. Comply with UL 1285 for fire-service mains if indicated.
  2. PVC Fabricated Fittings: AWWA C900, Class 150, with bell-and-spigot or double-bell ends. Include elastomeric gasket in each bell.
  3. PVC Molded Fittings: AWWA C907, Class 150, with bell-and-spigot or double-bell ends. Include elastomeric gasket in each bell.
  4. Push-on-Joint, Ductile-Iron Fittings: AWWA C110, ductile- or gray-iron standard pattern or AWWA C153, ductile-iron compact pattern.
    - a. Gaskets: AWWA C111, rubber.
  5. Mechanical-Joint, Ductile-Iron Fittings: AWWA C110, ductile- or gray-iron standard pattern or AWWA C153, ductile-iron compact pattern.
    - a. Glands, Gaskets, and Bolts: AWWA C111, ductile- or gray-iron glands, rubber gaskets, and steel bolts.

### 2.4 STAINLESS STEEL IN BUILDING RISER

- A. Continuous from the factory, no field formed fittings in the stainless steel riser. Field modifications are not allowed. Restrain with thrust block, per NFPA 24, rods as required by manufacture.

1. Inlet: AWWA C900/DIP
2. Outlet: AWWA 606

## 2.5 STEEL PIPE AND FITTINGS

- A. Threaded-End, Standard-Weight Steel Pipe: ASTM A 53/A 53M, ASTM A 135, or ASTM A 795, hot-dip galvanized where indicated and with factory- or field-formed threaded ends.
1. Cast-Iron Threaded Flanges: ASME B16.1.
  2. Malleable-Iron Threaded Fittings: ASME B16.3.
  3. Gray-Iron Threaded Fittings: ASME B16.4.
  4. Steel Threaded Pipe Nipples: ASTM A 733, made of ASTM A 53/A 53M or ASTM A 106, Schedule 40, seamless steel pipe hot-dip galvanized where indicated. Include ends matching joining method.
  5. Steel Threaded Couplings: ASTM A 865 hot-dip galvanized-steel pipe where indicated.
- B. Plain-End, Standard-Weight Steel Pipe: ASTM A 53/A 53M, ASTM A 135, or ASTM A 795 hot-dip galvanized-steel pipe where indicated.
1. Locking-Lug Fittings: UL 213, ductile-iron body with retainer lugs that require one-quarter turn to secure pipe in fitting not allowed.
- C. Plain-End, Standard-Weight Steel Pipe: ASTM A 53/A 53M, ASTM A 135, or ASTM A 795 hot-dip galvanized-steel pipe where indicated.
1. Steel Welding Fittings: ASTM A 234/A 234M, and ASME B16.9 or ASME B16.11.
  2. Steel Flanges and Flanged Fittings: ASME B16.5.
- D. Grooved-End, Standard-Weight Steel Pipe: ASTM A 53/A 53M, ASTM A 135, or ASTM A 795, hot-dip galvanized where indicated and with factory- or field-formed, roll-grooved ends.
1. Grooved-Joint Piping Systems:
    - a. Manufacturers:
      - 1) Anvil International, Inc.
      - 2) Bull Moose Tube, Inc
      - 3) Central Sprinkler Corp.
      - 4) Victaulic Co. of America.
      - 5) Ward Manufacturing.
      - 6) Wheatland Tube
    - b. Grooved-End Fittings: UL-listed, ASTM A 536, ductile-iron casting with OD matching steel-pipe OD.
    - c. Grooved-End-Pipe Couplings: UL 213 and AWWA C606, rigid pattern, unless otherwise indicated; gasketed fitting matching steel-pipe OD. Include ductile-iron housing with keys matching steel-pipe and fitting grooves, prelubricated rubber gasket listed for use with housing, and steel bolts and nuts.

- E. Threaded-End, Threadable, Thinwall Steel Pipe: ASTM A 135 or ASTM A 795, with wall thickness less than Schedule 40 and greater than Schedule 10, and with factory- or field-formed threaded ends.
1. Cast-Iron Threaded Flanges: ASME B16.1.
  2. Malleable-Iron Threaded Fittings: ASME B16.3.
  3. Gray-Iron Threaded Fittings: ASME B16.4.
  4. Steel Threaded Pipe Nipples: ASTM A 733, made of ASTM A 53/A 53M or ASTM A 106, Schedule 40, seamless steel pipe.
  5. Steel Threaded Couplings: ASTM A 865.
- F. Plain-End, Threadable, Thinwall Steel Pipe: ASTM A 135 or ASTM A 795, with wall thickness less than Schedule 40 and greater than Schedule 10.
1. Locking-Lug Fittings: UL 213, ductile-iron body with retainer lugs that require one-quarter turn to secure pipe in fitting not allowed.
- G. Plain-End, Threadable, Thinwall Steel Pipe: ASTM A 135 or ASTM A 795, with wall thickness less than Schedule 40 and greater than Schedule 10.
1. Steel Welding Fittings: ASTM A 234/A 234M, and ASME B16.9 or ASME B16.11.
  2. Steel Flanges and Flanged Fittings: ASME B16.5.
- H. Grooved-End, Threadable, Thinwall Steel Pipe: ASTM A 135 or ASTM A 795, with wall thickness less than Schedule 40 and greater than Schedule 10, and with factory- or field-formed, roll-grooved ends.
1. Grooved-Joint Piping Systems:
    - a. Manufacturers:
      - 1) Anvil International, Inc.
      - 2) Bull Moose Tube, Inc
      - 3) Central Sprinkler Corp.
      - 4) Victaulic Co. of America.
      - 5) Ward Manufacturing.
      - 6) Wheatland Tube
    - b. Grooved-End Fittings: UL-listed, ASTM A 536, ductile-iron casting with OD matching steel-pipe OD.
    - c. Grooved-End-Pipe Couplings: UL 213 and AWWA C606, rigid pattern, unless otherwise indicated; gasketed fitting matching steel-pipe OD. Include ductile-iron housing with keys matching steel-pipe and fitting grooves, prelubricated rubber gasket listed for use with housing, and steel bolts and nuts.
- I. Plain-End, Schedule 10 Steel Pipe: ASTM A 135 or ASTM A 795, Schedule 10 is not allowed.
- J. Plain-End, Nonstandard OD, Thinwall Steel Pipe: ASTM A 135 or ASTM A 795, with wall thickness less than Schedule 10 is not allowed.
- K. Plain-End, Hybrid Steel Pipe: ASTM A 135 or ASTM A 795, lightwall, with wall thickness less than Schedule 10 and greater than Schedule 5 is not allowed.

- L. Grooved-End, Hybrid Steel Pipe: ASTM A 135 or ASTM A 795, lightwall, with wall thickness less than Schedule 10 and greater than Schedule 5; with factory- or field-formed, roll-grooved ends are not allowed.
- M. Schedule 5 Steel Pipe: ASTM A 135 or ASTM A 795, lightwall, with plain ends is not allowed.

## 2.6 CPVC TUBE AND FITTINGS

- A. CPVC pipe is produced to the specifications of ASTM F442; Complete system in accordance with its listing limitations, including installation instructions. CPVC is not allowed on this project.
- B. Specially Listed Fittings Materials and Dimensions
  - 1. Schedule 80 CPVC Threaded fittings: ASTM F 437.
  - 2. Schedule 40 CPVC Socket-type fittings: ASTM F 438.
  - 3. Schedule 80 CPVC Socket-type fittings: ASTM F 439.

## 2.7 COPPER TUBE AND FITTINGS

- A. Soft Copper Tube: ASTM B 88, Type L, water tube, annealed temper; with plain ends.
  - 1. Copper fittings: ASME B16.18, cast-copper-alloy or ASME B16.22, wrought-copper, solder-joint pressure type. Furnish only wrought-copper fittings if indicated.
  - 2. Brazing Filler Metals: AWS A5.8, BCuP-3 or BCuP-4.
- B. Plain-End, Hard Copper Tube: ASTM B 88, Type K or ASTM B 88, Type L, water tube, drawn temper.
  - 1. Copper Fittings: ASME B16.18, cast-copper-alloy or ASME B16.22, wrought-copper, solder-joint pressure type. Furnish only wrought-copper fittings if indicated.
  - 2. Bronze Flanges: ASME B16.24, Class 150, with solder-joint end. Furnish Class 300 flanges if required to match tubing system.
  - 3. Copper Unions: MSS SP-123, cast-copper-alloy, hexagonal-stock body with ball-and-socket metal-to-metal seating surfaces, and solder-joint or threaded ends.
  - 4. Copper, Mechanically Formed Tee Option: For forming T-branch on copper water tube not allowed.
  - 5. Brazing Filler Metals: AWS A5.8, BCuP-3 or BCuP-4.
- C. Grooved-End, Hard Copper Tube: ASTM B 88, Type K or ASTM B 88, Type L, water tube, drawn temper; with factory- or field-formed, roll-grooved ends.
  - 1. Copper, Mechanically Formed Tee Option: For forming T-branch on copper water tube not allowed.
  - 2. Grooved-Joint Systems:
    - a. Manufacturers:
      - 1) Anvil International, Inc.
      - 2) Victaulic Co. of America.
    - b. Grooved-End Copper Fittings: ASTM B 75, copper tube or ASTM B 584, bronze casting. Fittings may have ends factory or field expanded to steel-pipe OD if required for copper tube systems using grooved-end-pipe couplings.



- c. Grooved-End-Tube Couplings: UL 213, rigid pattern, unless otherwise indicated; gasketed fitting equivalent to AWWA C606, but made to match copper-tube OD. Include ductile-iron housing with keys matching steel-pipe and fitting grooves, prelubricated rubber gasket listed for use with housing, and steel bolts and nuts. Use grooved-end-pipe couplings for tube and fitting that have expanded ends.

## 2.8 DIELECTRIC FITTINGS

- A. Assembly shall be copper alloy, ferrous, and insulating materials with ends matching piping system.
- B. Dielectric Unions: Factory-fabricated assembly, designed for 250-psig minimum working pressure at 180 deg F. Include insulating material that isolates dissimilar materials and ends with inside threads according to ASME B1.20.1.
  1. Manufacturers:
    - a. Capitol Manufacturing Co.
    - b. Central Plastics Company.
    - c. Epco Sales, Inc.
    - d. Hart Industries International, Inc.
    - e. Watts Industries, Inc.; Water Products Div.
    - f. Zurn Industries, Inc.; Wilkins Div.
- C. Dielectric Flanges: Factory-fabricated companion-flange assembly, for 175-psig minimum working-pressure rating as required for piping system.
  1. Manufacturers:
    - a. Capitol Manufacturing Co.
    - b. Central Plastics Company.
    - c. Epco Sales, Inc.
    - d. Watts Industries, Inc.; Water Products Div.
- D. Dielectric Flange Insulation Kits: Components for field assembly shall include CR or phenolic gasket, PE or phenolic bolt sleeves, phenolic washers, and steel backing washers.
  1. Manufacturers:
    - a. Advance Products and Systems, Inc.
    - b. Calpico, Inc.
    - c. Central Plastics Company.
    - d. Pipeline Seal and Insulator, Inc.
    - e. Insert manufacturer's name.
- E. Dielectric Couplings: Galvanized steel with inert and noncorrosive thermoplastic lining and threaded ends and 300-psig working-pressure rating at 225 deg F.
  1. Manufacturers:
    - a. Calpico, Inc.
    - b. Lochinvar Corp.

- F. Dielectric Nipples: Electroplated steel with inert and noncorrosive thermoplastic lining, with combination of plain, threaded, or grooved ends and 300-psig working-pressure rating at 225 deg F.
  - 1. Manufacturers:
    - a. Perfection Corporation.
    - b. Precision Plumbing Products, Inc.
    - c. Victaulic Co. of America.

## 2.9 FLEXIBLE SPRINKLER DROPS

- A. Flexible connectors shall be FM approved with exterior wire braid and have materials suitable for system fluid. Include 175-psig minimum working-pressure rating and ends according to the following:
  - 1. NPS 1: Threaded.
- B. Manufacturers:
  - 1. Flex-Head
  - 2. Victaulic
- C. Stainless-Steel-Hose/Steel Pipe, Flexible Connectors: Corrugated, stainless-steel, inner tubing covered with stainless-steel wire braid. Include steel nipples or flanges, welded to hose.
- D. Stainless-Steel-Hose/Stainless-Steel Pipe, Flexible Connectors: Corrugated, stainless-steel, inner tubing covered with stainless-steel wire braid. Include stainless-steel nipples or flanges, welded to hose.

## 2.10 FLEXIBLE PIPE CONNECTORS (SEISMIC)

- A. Flexible connectors shall be FM approved with exterior wire braid and have materials suitable for system fluid. Include 175-psig minimum working-pressure rating and ends according to the following:
  - 1. NPS 2 and Smaller: Threaded.
  - 2. NPS 2-1/2 and Larger: Flanged.
  - 3. Option for NPS 2-1/2 and Larger: Grooved for use with grooved-end-pipe couplings.
- B. Manufacturers:
  - 1. Flexicraft Industries.
  - 2. Flex-Pression, Ltd.
  - 3. Metraflex, Inc.
- C. Bronze-Hose, Flexible Connectors: Corrugated, bronze, inner tubing covered with bronze wire braid. Include copper-tube ends or bronze flanged ends, braze welded to hose.
- D. Stainless-Steel-Hose/Steel Pipe, Flexible Connectors: Corrugated, stainless-steel, inner tubing covered with stainless-steel wire braid. Include steel nipples or flanges, welded to hose.

- E. Stainless-Steel-Hose/Stainless-Steel Pipe, Flexible Connectors: Corrugated, stainless-steel, inner tubing covered with stainless-steel wire braid. Include stainless-steel nipples or flanges, welded to hose.

#### 2.11 CORROSION-PROTECTIVE ENCASEMENT FOR PIPING

- A. Encasement for Underground Metal Piping: ASTM A 674 or AWWA C105, PE film, 0.008-inch minimum thickness, tube or sheet.

#### 2.12 SPRINKLER SPECIALTY FITTINGS

- A. Sprinkler specialty fittings shall be FMG approved with 175-psig minimum working-pressure rating, and made of materials compatible with piping. Sprinkler specialty fittings shall have 250-psig minimum working-pressure rating if fittings are components of high-pressure piping systems.
- B. Sprinkler Drain and Alarm Test Fittings: Cast- or ductile-iron body, with threaded or locking-lug inlet and outlet, test valve, and orifice and sight glass.
  - 1. Manufactures:
    - a. Central Sprinkler Corp.
    - b. Fire-End and Croker Corp.
    - c. Viking Corp.
    - d. Victaulic Co. of America.
- C. Sprinkler Branch-Line Test Fittings: Brass body with threaded inlet, capped drain outlet, and threaded outlet for sprinkler.
- D. Sprinkler Inspector's Test Fitting: Cast- or ductile-iron housing with threaded inlet and drain outlet and sight glass.
- E. Drop-Nipple Fittings: UL 1474, adjustable with threaded inlet and outlet, and seals.

#### 2.13 LISTED FIRE-PROTECTION VALVES

- A. Valves shall be FMG approved, with 175-psig minimum pressure rating. Valves shall have 250-psig minimum pressure rating if valves are components of high-pressure piping system.
- B. Gate Valves with Wall Indicator Posts:
  - 1. Gate Valves: UL 262, cast-iron body, bronze mounted, with solid disc, nonrising stem, operating nut, and flanged ends.
  - 2. Indicator Posts: UL 789, horizontal-wall type, cast-iron body, with hand wheel, extension rod, locking device, and cast-iron barrel.
  - 3. Manufacturers:
    - a. Grinnell Fire Protection.
    - b. McWane, Inc.; Kennedy Valve Div.
    - c. NIBCO.
    - d. Stockham.

- C. Ball Valves: Comply with UL 1091, except with ball instead of disc.
1. NPS 1-1/2 and Smaller: Bronze body with threaded ends.
  2. NPS 2 and NPS 2-1/2: Bronze body with threaded ends or ductile-iron body with grooved ends.
  3. NPS 3: Ductile-iron body with grooved ends.
  4. Manufacturers:
    - a. NIBCO.
    - b. Victaulic Co. of America.
- D. Butterfly Valves: UL 1091.
1. NPS 2 and Smaller: Bronze body with threaded ends.
    - a. Manufacturers:
      - 1) Global Safety Products, Inc.
      - 2) Milwaukee Valve Company.
  2. NPS 2-1/2 and Larger: Bronze, cast-iron, or ductile-iron body; wafer type or with flanged or grooved ends.
    - a. Manufacturers:
      - 1) Central Sprinkler Corp.
      - 2) McWane, Inc.; Kennedy Valve Div.
      - 3) Mueller Company.
      - 4) NIBCO.
      - 5) Victaulic Co. of America.
- E. Check Valves NPS 2 and Larger: UL 312, swing type, cast-iron body with flanged or grooved ends.
1. Manufacturers:
    - a. American Cast Iron Pipe Co.; Waterous Co.
    - b. Central Sprinkler Corp.
    - c. Clow Valve Co.
    - d. Crane Co.; Crane Valve Group; Crane Valves.
    - e. Crane Co.; Crane Valve Group; Jenkins Valves.
    - f. Fivalco
    - g. Globe Fire Sprinkler Corporation.
    - h. Grinnell Fire Protection.
    - i. Hammond Valve.
    - j. McWane, Inc.; Kennedy Valve Div.
    - k. Mueller Company.
    - l. NIBCO.
    - m. Potter-Roemer; Fire Protection Div.
    - n. Reliable Automatic Sprinkler Co., Inc.
    - o. Star Sprinkler Inc.
    - p. Stockham.
    - q. United Brass Works, Inc.
    - r. Victaulic Co. of America.
    - s. Watts Industries, Inc.; Water Products Div.

## F. Gate Valves: UL 262, OS&amp;Y type.

## 1. NPS 2 and Smaller: Bronze body with threaded ends.

## a. Manufacturers:

- 1) Crane Co.; Crane Valve Group; Crane Valves.
- 2) Fivalco.
- 3) Hammond Valve.
- 4) NIBCO.
- 5) United Brass Works, Inc.

## 2. NPS 2-1/2 and Larger: Cast-iron body with flanged ends.

## a. Manufacturers:

- 1) Clow Valve Co.
- 2) Crane Co.; Crane Valve Group; Crane Valves.
- 3) Crane Co.; Crane Valve Group; Jenkins Valves.
- 4) Fivalco
- 5) Hammond Valve.
- 6) Milwaukee Valve Company.
- 7) Mueller Company.
- 8) NIBCO.
- 9) United Brass Works, Inc.

## G. Indicating Valves: UL 1091, with integral indicating device and ends matching connecting piping.

1. Indicator: Electrical, 115-V ac, prewired, single-circuit, supervisory switch and Visual.
2. NPS 2 and Smaller: Ball or butterfly valve with bronze body and threaded ends.

## a. Manufacturers:

- 1) Milwaukee Valve Company.
- 2) NIBCO.
- 3) Victaulic Co. of America.

## 3. NPS 2-1/2 and Larger: Butterfly valve with cast- or ductile-iron body; wafer type or with flanged or grooved ends.

## a. Manufacturers:

- 1) Central Sprinkler Corp.
- 2) Grinnell Fire Protection.
- 3) McWane, Inc.; Kennedy Valve Div.
- 4) Milwaukee Valve Company.
- 5) NIBCO.
- 6) Victaulic Co. of America.

## H. Supervised Normally Closed Valve

1. Indicator: Electrical, 115-V ac, prewired, single-circuit, supervisory switch and visual to send signal on partial close.

## a. Manufactures:

- 1) NIBCO.
- 2) Victaulic Co. of America.

## 2.14 UNLISTED GENERAL-DUTY VALVES

- A. Ball Valves NPS 2 and Smaller: MSS SP-110, 2-piece copper-alloy body with chrome-plated brass ball, 600-psig minimum CWP rating, blowout-proof stem, and threaded ends.
- B. Check Valves NPS 2 and Smaller: MSS SP-80, Type 4, Class 125 minimum, swing type with bronze body, nonmetallic disc, and threaded ends.
- C. Gate Valves NPS 2 and Smaller: MSS SP-80, Type 2, Class 125 minimum, with bronze body, solid wedge, and threaded ends.
- D. Globe Valves NPS 2 and Smaller: MSS SP-80, Type 2, Class 125 minimum, with bronze body, nonmetallic disc, and threaded ends.

## 2.15 SPECIALTY VALVES

- A. Sprinkler System Control Valves: FMG approved, cast- or ductile-iron body with flanged or grooved ends, and 175-psig minimum pressure rating. Control valves shall have 250-psig minimum pressure rating if valves are components of high-pressure piping system.
  1. Manufacturers:
    - a. Globe Fire Sprinkler Corporation.
    - b. Reliable Automatic Sprinkler Co., Inc.
    - c. Victaulic Co. of America.
    - d. Viking Corp.
- B. Automatic Drain Valves: UL 1726, NPS 3/4, ball-check device with threaded ends.
  1. Manufacturers:
    - a. Grinnell Fire Protection.

## 2.16 SPRINKLERS

- A. Sprinklers shall be UL listed or FMG approved, with 175-psig minimum pressure rating. Sprinklers shall have 250-psig minimum 300-psig pressure rating if sprinklers are components of high-pressure piping system.
- B. Manufacturers:
  1. Globe Fire Sprinkler Corporation.
  2. Reliable Automatic Sprinkler Co., Inc.
  3. Victaulic Co. of America.
  4. Viking Corp.
  5. Tyco Fire

- C. Automatic Sprinklers: With heat-responsive element complying with the following:
  - 1. UL 199, for nonresidential applications.
- D. Sprinkler Types and Categories: Nominal 1/2-inch orifice for "Ordinary" temperature classification rating, unless otherwise indicated or required by application.
  - 1. Open Sprinklers: UL 199, without heat-responsive element.
    - a. Orifice: 1/2 inch, with discharge coefficient K between 5.3 and 5.8.
    - b. Orifice: 17/32 inch, with discharge coefficient K between 7.4 and 8.2.
- E. Sprinkler types, features, and options as follows:
  - 1. Concealed ceiling sprinklers, including cover plate.
  - 2. Extended-coverage sprinklers, not allowed unless approved in writing prior to bidding.
  - 3. Flow-control sprinklers, with automatic open and shutoff feature.
  - 4. Flush ceiling sprinklers, including escutcheon, not allowed.
  - 5. Institution sprinklers, made with a small, breakaway projection.
  - 6. Pendent sprinklers.
  - 7. Pendent, dry-type sprinklers.
  - 8. Quick-response sprinklers.
  - 9. Sidewall sprinklers.
  - 10. Sidewall, dry-type sprinklers.
  - 11. Upright sprinklers.
- F. Sprinkler Finishes: Chrome plated, bronze, and painted. Finishes as approved by FM Global.
- G. Special Coatings: Wax, lead, and corrosion-resistant paint.
- H. Sprinkler Escutcheons: Materials, types, and finishes for the following sprinkler mounting applications. Escutcheons for concealed, flush, and recessed-type sprinklers are specified with sprinklers.
  - 1. Ceiling Mounting: Flat plate concealed, white.
  - 2. Sidewall Mounting: Flat plate concealed, white.
- I. Sprinkler Guards: Wire-cage type, including fastening device for attaching to sprinkler.

## 2.17 ALARM DEVICES

- A. Alarm-device types shall match piping and equipment connections.
- B. Electrically Operated Alarm: Horn/Strobe, NEMA 3R minimum suitable for outdoor use.
  - 1. Manufacturers:
    - a. Potter Electric Signal Company.
    - b. System Sensor.
- C. Water-Flow Indicator: UL 346, electrical-supervision, paddle-operated-type, water-flow detector with 250-psig pressure rating and designed for horizontal or vertical installation. Include two single-pole, double-throw circuit switches for isolated alarm and auxiliary

contacts, 7 A, 125-V ac and 0.25 A, 24-V dc; complete with factory-set, field-adjustable retard element to prevent false signals and tamperproof cover that sends signal if removed.

1. Manufacturers:
  - a. ADT Security Services, Inc.
  - b. Grinnell Fire Protection.
  - c. ITT McDonnell & Miller.
  - d. Potter Electric Signal Company.
  - e. System Sensor.
  - f. Viking Corp.
  - g. Watts Industries, Inc.; Water Products Div.

D. Pressure Switch: UL 753, electrical-supervision-type, water-flow switch with retard feature. Include single-pole, double-throw, normally closed contacts and design that operates on rising pressure and signals water flow.

1. Manufacturers:
  - a. Grinnell Fire Protection.
  - b. Potter Electric Signal Company.
  - c. System Sensor.
  - d. Viking Corp.

E. Valve Supervisory Switch: UL 753, electrical, single-pole, double-throw switch with normally closed contacts. Include design that signals controlled valve is in other than fully open position.

1. Manufacturers:
  - a. McWane, Inc.; Kennedy Valve Div.
  - b. Potter Electric Signal Company.
  - c. System Sensor.

F. Indicator-Post Supervisory Switch: UL 753, electrical, single-pole, double-throw switch with normally closed contacts. Include design that signals controlled indicator-post valve is in other than fully open position.

1. Manufacturers:
  - a. Potter Electric Signal Company.
  - b. System Sensor.

## 2.18 PRESSURE GAGES

A. Manufacturers:

1. Brecco Corporation.
2. Dresser Equipment Group; Instrument Div.
3. Marsh Bellofram.
4. WIKA Instrument Corporation.

B. Description: UL 393, 3-1/2- to 4-1/2-inch- diameter, dial pressure gage with range of 0 to 250 psig minimum.



1. Water System Piping: Include caption "WATER" or "AIR/WATER" on dial face.
2. Air System Piping: Include retard feature and caption "AIR" or "AIR/WATER" on dial face.

## 2.19 DOUBLE CHECK VALVE ASSEMBLIES

### A. Manufacturers

1. Ames
2. Backflow Direct
3. Febco
4. Wilkins
5. Watts

- B. Description; Resilient seated, spring loaded with testable outlets provided, as required by Authorities Having Jurisdiction.

## PART 3 - EXECUTION

### 3.1 PREPARATION

- A. Obtain Engineer's Water Analysis or fire-hydrant flow test. Use results for system design calculations required in "Quality Assurance" Article in Part 1 of this Section.

### 3.2 EARTHWORK

- A. Refer to Division 31 Section "Earth Moving" for excavating, trenching, and backfilling.

### 3.3 EXAMINATION

- A. Examine roughing-in for hose connections and stations to verify actual locations of piping connections before installation.
- B. Examine walls and partitions for suitable thicknesses, fire- and smoke-rated construction, framing for hose-station cabinets, and other conditions where hose connections and stations are to be installed.
- C. Proceed with installation only after unsatisfactory conditions have been corrected.

### 3.4 PIPING APPLICATIONS

- A. Shop weld pipe joints where welded piping is indicated.
- B. Do not use welded joints for galvanized-steel pipe.
- C. Flanges, flanged fittings, unions, nipples, and transition and special fittings with finish and pressure ratings same as or higher than system's pressure rating may be used in aboveground applications, unless otherwise indicated.

- D. Piping between Fire Department Connections and Check Valves: Galvanized, standard-weight steel pipe with grooved ends; grooved-end fittings; grooved-end-pipe couplings; and grooved joints.
- E. Underground Service-Entrance Piping: Ductile-iron, push-on or mechanical-joint pipe and fittings and restrained joints. Include corrosion-protective encasement.
- F. Sprinkler Main Piping: Use the following:
  - 1. NPS 6 and Smaller: Standard-weight steel pipe with threaded ends, or grooved ends. No plain ends allowed.
  - 2. Outlets shall be welded.
    - a. Victaulic Brand Mechanical tee fittings may be used in lieu of welded outlets.
- G. Branch line piping: Use the following:
  - 1. NPS 1-1/4 and Smaller: Threadable steel pipe with threaded ends; cast- or malleable-iron threaded fittings; and threaded joints.
    - a. Victaulic Brand Mechanical tee fittings may be used
- H. Standpipes and mains: Use the following:
  - 1. NPS 4 to NPS 6: Schedule 40 steel pipe with grooved ends & Welded outlets.
  - 2. NPS 3 and Smaller: Schedule 40 steel pipe with threaded ends, or grooved ends. No plain ends allowed.

### 3.5 VALVE APPLICATIONS

- A. Drawings indicate valve types to be used. Where specific valve types are not indicated, the following requirements apply:
  - 1. Fire-Protection-Service Valves: UL listed and FM approved for applications where required by NFPA 13 and NFPA 14.
  - 2. General-Duty Valves: For applications where UL-listed and FM-approved valves are not required by NFPA 13 and NFPA 14.
    - a. Shutoff Duty: Use gate, ball, or butterfly valves.
    - b. Throttling Duty: Use globe, ball, or butterfly valves.

### 3.6 JOINT CONSTRUCTION

- A. Refer to Division 23 Section "Common Work Result for HVAC" for basic piping joint construction.
- B. Ductile-Iron-Piping, Grooved Joints: Use ductile-iron pipe with radius-cut-grooved ends; ductile-iron, grooved-end fittings; and ductile-iron, keyed couplings. Assemble joints with couplings, gaskets, lubricant, and bolts according to coupling manufacturer's written instructions.
- C. Steel-Piping, Grooved Joints: Use Schedule 40 steel pipe with cut or roll-grooved ends and Schedule 30 or thinner steel pipe with roll-grooved ends; steel, grooved-end fittings; and

steel, keyed couplings. Assemble joints with couplings, gaskets, lubricant, and bolts according to coupling manufacturer's written instructions. Use gaskets listed for dry-pipe service for dry piping.

### 3.7 WATER-SUPPLY CONNECTION

- A. Install shutoff Backflow preventions assemblies, valve, pressure gage's, drain, and other accessories at connection to water service.

### 3.8 PIPING INSTALLATION

- A. Refer to Division 23 Section "Common Work Result for HVAC" for basic piping installation.
- B. Locations and Arrangements: Drawing plans, schematics, and diagrams indicate general location and arrangement of piping. Install piping as indicated, as far as practical.
  - 1. Deviations from approved working plans for piping require written approval from authorities having jurisdiction. File written approval with Architect before deviating from approved working plans.
- C. Install mechanical sleeve seal at pipe penetrations in basement and foundation walls. Refer to Division 23 Section "Common Work Result for HVAC."
- D. Use approved fittings to make changes in direction, branch takeoffs from mains, and reductions in pipe sizes.
- E. Install unions adjacent to each valve in pipes NPS 2 and smaller. Unions are not required on flanged devices or in piping installations using grooved joints.
- F. Install flanges or flange adapters on valves, apparatus, and equipment having NPS 2-1/2 and larger connections.
- G. Install sprinkler piping with drains for complete system drainage.
- H. Install sprinkler zone control valves, check valves, test assemblies, and drain risers adjacent to standpipes when sprinkler piping is connected to standpipes.
- I. Install alarm devices in piping systems.
- J. Hangers and Supports: Comply with NFPA 13 for hanger materials. Install according to NFPA 13 for sprinkler piping and to NFPA 14 for standpipes.
  - 1. No powder driven studs allowed.
  - 2. Wrap-around braces are to be provided at end of branch lines.
- K. Earthquake Protection: Install piping according to NFPA 13-9.3 requirements, to protect from earthquake damage. Seismic Bracing shall be designed to withstand vertical forces and movement.
- L. Install piping with grooved joints according to manufacturer's written instructions. Construct rigid piping joints, unless otherwise indicated, or required by NFPA 13 for flexibility in seismic zones.

- M. Install pressure gages on riser or feed main, at each sprinkler test connection, and at top of each standpipe. Include pressure gages with connection not less than NPS 1/4 and with soft metal seated globe valve, arranged for draining pipe between gage and valve. Install gages to permit removal, and install where they will not be subject to freezing.
- N. When a fire pipe crosses a seismic expansion joint it shall have a Metraflex fire loop installed at the joint in accordance with NFPA 13 chapter 9.

### 3.9 SPECIALTY SPRINKLER FITTING INSTALLATION

- A. Install specialty sprinkler fittings according to manufacturer's written instructions.

### 3.10 VALVE INSTALLATION

- A. Refer to Division 23 Section "Valves" for installing general-duty valves. Install fire-protection specialty valves, trim, fittings, controls, and specialties according to NFPA 13 and NFPA 14, manufacturer's written instructions, and authorities having jurisdiction.
- B. Valves: Install fire-protection-service valves supervised-open, located to control sources of water supply except from fire department connections. Provide permanent identification signs indicating portion of system controlled by each valve.

### 3.11 SPRINKLER APPLICATIONS

- A. General: All sprinklers are to be quick response type. Sprinkler heads shall be of the latest design closed spray type for 155°F unless specified otherwise or required by code. Extended coverage heads shall not be used. Orifices larger than 1/2" may be used as required by density and spacing demands. Use sprinklers according to the following applications:
  - 1. Rooms without Ceilings: Upright and/or pendent sprinklers. Provide mechanical guards on all heads at or below 7'-0" height above the floor or where damage from room occupant use may occur.
  - 2. Rooms with Ceilings: Concealed sprinklers unless indicated otherwise.
  - 3. Wall Mounting: Concealed sidewall sprinklers unless indicated otherwise.
  - 4. Institutional sprinklers shall be installed in areas of detention, correctional or mental health care facilities.
  - 5. Spaces Subject to Freezing: Upright; pendent, dry-type; and sidewall, dry-type sprinklers.
  - 6. Provide freeze proof type automatic sprinkler heads serving unconditioned spaces, areas subject to freezing and in other areas requiring their use.
  - 7. Heads located within the air streams of unit heaters or other heat-emitting equipment shall be selected for proper temperature rating.
  - 8. Sprinkler Finishes: Use sprinklers with the following finishes:
    - a. Upright, Pendent, and Sidewall Sprinklers: Chrome in finished spaces exposed to view; rough bronze in unfinished spaces not exposed to view.
    - b. Concealed Sprinklers: Rough brass, with White cover plate to match ceiling color.
    - c. Semi-Recessed Sprinklers: White, with FMG approved white escutcheon.
- B. Sprinklers: Use the following:
  - 1. All sprinklers shall be listed, quick response type.

2. Sprinkler in future finish spaces (shelled) 10' x 10' spacing shall be pendants/uprights installed with 1 x ½" bushing, to accommodate future finishes.
3. Finish ceiling spaces shall have flat-plate concealed sprinklers.

### 3.12 SPRINKLER INSTALLATION

- A. Every effort shall be required to ensure that the heads form a symmetrical pattern in the ceiling with the ceiling grid if included, as well as lights, diffusers and grilles. Offsets shall be made in piping to accommodate ductwork in the ceiling. Heads shall be symmetrical in all ceilings and all piping run parallel or perpendicular to building lines. Heads shall be linearly aligned in corridors.
  1. In no case shall sprinkler heads be installed closer than approved distances from ceiling obstructions and HVAC ductwork.
  2. Sprinkler heads shall not conflict with tile grids.
  3. Sprinkler heads shall be located near center of corridors.
- B. Where layout of sprinkler heads is shown on reflected ceiling plans the locations shall be followed unless approval is obtained from the Architect or such locations shown do not meet the requirements of NFPA-13. In either case, approval of the Architect shall be obtained in writing before sprinkler head locations are changed. If the installation of additional heads is needed to conform to NFPA 13 requirements in areas where heads are shown on reflected ceiling plans, they shall be included in the contract price.
- C. Install sprinklers in patterns indicated.
- D. Do not install pendent or sidewall, wet-type sprinklers in areas subject to freezing. Use dry-type sprinklers with water supply from heated space.
- E. Future finish shelled and tenant finish; Shell spaces shall be piped to accommodate future. Install sprinklers with 1" x ½" bushings, and space heads at a maximum spacing of 100 sq. ft. per head. Occupancy shall be Ordinary-Hazard Group 1 Design.
- F. Concealed type sprinkler shall be installed in the following areas:
  1. All areas.

### 3.13 CONNECTIONS

- A. Connect water-supply piping and standpipes and sprinklers where indicated.
- B. Connect piping to specialty valves, hose valves, specialties, fire department connections, and accessories.
- C. Electrical Connections: Power wiring is specified in Division 28.
- D. Connect alarm devices to fire alarm.

### 3.14 LABELING AND IDENTIFICATION

- A. Install labeling and pipe markers on equipment and piping according to requirements in NFPA 13 and NFPA 14 and in Division 23 Section "Common Work Result for HVAC."

### 3.15 FIELD QUALITY CONTROL

- A. Flush, test, and inspect sprinkler piping according to NFPA 13, "System Acceptance" Chapter.
- B. Flush, test, and inspect standpipes according to NFPA 14, "Tests and Inspection" Chapter.
- C. Replace piping system components that do not pass test procedures and retest to demonstrate compliance. Repeat procedure until satisfactory results are obtained.
- D. When making a mechanical tee connection the coupon shall be attached at the mechanical tee.
- E. Report test results promptly and in writing to Architect and authorities having jurisdiction.
- F. Whether the underground serving the sprinkler system is done by this contractor or another, this contractor will be responsible to assure and have in his possession a certificate that the underground has been flushed and tested by the contractor who installed it in accordance with NFPA-24 prior to connection of the underground piping to the overhead sprinkler system.

### 3.16 CLEANING

- A. Clean dirt and debris from sprinklers.
- B. Remove and replace sprinklers having paint other than factory finish.

### 3.17 PROTECTION

- A. Protect sprinklers from damage until Substantial Completion.

### 3.18 COMMISSIONING

- A. Verify that specialty valves, trim, fittings, controls, and accessories are installed and operate correctly.
- B. Verify that specified tests of piping are complete and that "Material Test Certificates" are complete.
- C. Verify that damaged sprinklers and sprinklers with paint or coating not specified are replaced with new, correct type.
- D. Verify that sprinklers are correct types, have correct finishes and temperature ratings, and have guards as required for each application.
- E. Verify that hose connections and fire department connections have threads compatible with local fire department equipment.
- F. Fill wet-pipe sprinkler piping with water.
- G. Fill standpipes with water.
- H. Verify that hose connections are correct type and size.

- I. Coordinate with fire alarm tests. Operate as required.

### 3.19 DEMONSTRATION & TESTS

- A. Demonstrate equipment, specialties, and accessories. Review operating and maintenance information.
- B. All tests will be conducted as required by the local authority having jurisdiction, and in no case less than those required by NFPA standards. As a minimum, piping in the sprinkler system shall be tested at a water pressure at 200 psi for a period of not less two hours, or at 50 psi in excess of the normal pressure when the normal pressure is above 150 psi. Bracing shall be in place, and air shall be removed from the system through the hydrants and drain valves before the test pressure is applied. No apparent leaks will be permitted on interior or underground piping.
- C. The local jurisdiction having authority and the Utah State Fire Marshal's office (where required) shall be notified at least three working days in advance of all tests and flushing. This includes any flushing of underground, hydrostatic testing, or flow testing that may be required.
- D. This contractor shall make all the required tests to the sprinkler system as required by code. He shall be responsible to assure that the Contractor Test Certificates for the overhead, backflow and underground work are completed and delivered to the owner's insurance underwriter to assure proper insurance credit.
- E. All tests requiring the witnessing by local authorities will be the responsibility of this contractor. If tests are not run or do not have the proper witness, then they will be run later and all damage caused by the system, or caused in uncovering the system for such test, will be borne by this contractor.

### 3.20 WARRANTY

- A. This contractor shall warranty the sprinkler system and all its components for one year from the date of acceptance by the owner. Any costs incurred to extend any warranties of materials to assure this time frame shall be borne by this contractor.
- B. Provide Operation and Maintenance Manuals with correct as-builts test certificates and warranties included. A minimum 6 sets to be provided in red 3-ring binders. Include a current adopted version of NFPA 25 softbound copy left with owner.
- C. Electronic copy of AutoCAD as-built drawings shall also be provided on CD, with each O&M Manual.

### 3.21 FIELD QUALITY CONTROL

- A. Flush, test and inspect sprinkler piping according to NFPA 13, "System Acceptance" Chapter.
- B. Replace piping system components that do not pass test procedures and retest to demonstrate compliance. Repeat procedure until satisfactory results are obtained.
- C. Report test results promptly and in writing to Architect and authorities having jurisdiction.

END OF SECTION 211000



**SECTION 22 05 00 - COMMON WORK RESULTS FOR PLUMBING**

## PART 1 - GENERAL

## 1.1 RELATED DOCUMENTS

- A. Drawings and general provisions of the Contract, including General and Supplementary Conditions and Division 01 Specification Sections, apply to this Section.

## 1.2 SUMMARY

- A. This Section includes the following:
  1. Piping materials and installation instructions common to most piping systems.
  2. Transition fittings.
  3. Dielectric fittings.
  4. Mechanical sleeve seals.
  5. Sleeves.
  6. Escutcheons.
  7. Grout.
  8. Equipment installation requirements common to equipment sections.
  9. Painting and finishing.
  10. Concrete bases.
  11. Supports and anchorages.
  12. Link Seal

## 1.3 SEISMIC REQUIREMENTS

- A. Seismic Performance: Equipment, pipe hangers and supports shall withstand the effects of earthquake motions determined according to SEI/ASCE 7 and with the requirements specified in Section 22 0548 "Vibration and Seismic Controls for Plumbing Piping and Equipment."
  1. For components with a seismic importance factor of 1.0 the term "withstand" means "the system will remain in place without separation of any parts when subjected to the seismic forces specified."
  2. For components with a seismic importance factor of 1.5 the term "withstand" means "the system will remain in place without separation of any parts when subjected to the seismic forces specified and the system will be fully operational after the seismic event."

## 1.4 DEFINITIONS

- A. Finished Spaces: Spaces other than mechanical and electrical equipment rooms, furred spaces, pipe chases, unheated spaces immediately below roof, spaces above ceilings, unexcavated spaces, and crawlspaces.

- B. Exposed, Interior Installations: Exposed to view indoors. Examples include finished occupied spaces and mechanical equipment rooms, accessible pipe shafts, accessible plumbing chases and accessible tunnels.
- C. Exposed, Exterior Installations: Exposed to view outdoors or subject to outdoor ambient temperatures and weather conditions. Examples include rooftop locations.
- D. Concealed, Interior Installations: Concealed from view and protected from physical contact by building occupants. Examples include above ceilings and in chases.
- E. Concealed, Exterior Installations: Concealed from view and protected from weather conditions and physical contact by building occupants but subject to outdoor ambient temperatures. Examples include installations within unheated shelters.
- F. The following are industry abbreviations for rubber materials:
  - 1. EPDM: Ethylene-propylene-diene terpolymer rubber.
  - 2. NBR: Acrylonitrile-butadiene rubber.

#### 1.5 SUBMITTALS

- A. Product Data: For the following:
  - 1. Transition fittings.
  - 2. Dielectric fittings.
  - 3. Mechanical sleeve seals.
  - 4. Escutcheons.
- B. Welding certificates.

#### 1.6 QUALITY ASSURANCE

- A. Steel Support Welding: Qualify processes and operators according to AWS D1.1, "Structural Welding Code--Steel."
- B. Electrical Characteristics for Plumbing Equipment: Equipment of higher electrical characteristics may be furnished provided such proposed equipment is approved in writing and connecting electrical services, circuit breakers, and conduit sizes are appropriately modified. If minimum energy ratings or efficiencies are specified, equipment shall comply with requirements.

#### 1.7 DELIVERY, STORAGE, AND HANDLING

- A. Deliver pipes and tubes with factory-applied end caps. Maintain end caps through shipping, storage, and handling to prevent pipe end damage and to prevent entrance of dirt, debris, and moisture.
- B. Store plastic pipes protected from direct sunlight. Support to prevent sagging and bending.

## 1.8 COORDINATION

- A. Arrange for pipe spaces, chases, slots, and openings in building structure during progress of construction, to allow for plumbing installations.
- B. Coordinate installation of required supporting devices and set sleeves in poured-in-place concrete and other structural components as they are constructed.
- C. Coordinate requirements for access panels and doors for plumbing items requiring access that are concealed behind finished surfaces. Access panels and doors are specified in Division 08 Section "Access Doors and Frames."

## PART 2 - PRODUCTS

## 2.1 MANUFACTURERS

- A. In other Part 2 articles where subparagraph titles below introduce lists, the following requirements apply for product selection:
  - 1. Manufacturers: Subject to compliance with requirements, provide products by the manufacturers specified.

## 2.2 PIPE, TUBE, AND FITTINGS

- A. Refer to individual Division 22 piping Sections for pipe, tube, and fitting materials and joining methods.
- B. Pipe Threads: ASME B1.20.1 for factory-threaded pipe and pipe fittings.

## 2.3 JOINING MATERIALS

- A. Refer to individual Division 22 piping Sections for special joining materials not listed below.
- B. Pipe-Flange Gasket Materials: Suitable for chemical and thermal conditions of piping system contents.
  - 1. ASME B16.21, nonmetallic, flat, asbestos-free, 1/8-inch maximum thickness unless thickness or specific material is indicated.
    - a. Full-Face Type: For flat-face, Class 125, cast-iron and cast-bronze flanges.
    - b. Narrow-Face Type: For raised-face, Class 250, cast-iron and steel flanges.
  - 2. AWWA C110, rubber, flat face, 1/8 inch thick, unless otherwise indicated; and full-face or ring type, unless otherwise indicated.
- C. Flange Bolts and Nuts: ASME B18.2.1, carbon steel, unless otherwise indicated.

- D. Plastic, Pipe-Flange Gasket, Bolts, and Nuts: Type and material recommended by piping system manufacturer, unless otherwise indicated.
- E. Solder Filler Metals: ASTM B 32, lead-free alloys. Include water-flushable flux according to ASTM B 813.
- F. Brazing Filler Metals: AWS A5.8, BCuP Series, copper-phosphorus alloys for general-duty brazing, unless otherwise indicated; and AWS A5.8, BAg1, silver alloy for refrigerant piping, unless otherwise indicated.

## 2.4 TRANSITION FITTINGS

- A. Flexible Transition Couplings for Underground Nonpressure Drainage Piping: ASTM C 1173 with elastomeric sleeve, ends same size as piping to be joined, and corrosion-resistant metal band on each end.

- 1. Manufacturers:

- a. Cascade Waterworks Mfg. Co.
- b. Fernco, Inc.
- c. Mission Rubber Company.
- d. Plastic Oddities, Inc.

## 2.5 DIELECTRIC FITTINGS

- A. Description: Combination fitting of copper alloy and ferrous materials with threaded, solder-joint, plain, or weld-neck end connections that match piping system materials.
- B. Insulating Material: Suitable for system fluid, pressure, and temperature.
- C. Dielectric Unions: Factory-fabricated, union assembly, for 250-psig minimum working pressure at 180 deg F.

- 1. Manufacturers:

- a. Capitol Manufacturing Co.
- b. Central Plastics Company.
- c. Eclipse, Inc.
- d. Epco Sales, Inc.
- e. Hart Industries, International, Inc.
- f. Watts Industries, Inc.; Water Products Div.
- g. Zurn Industries, Inc.; Wilkins Div.

- D. Dielectric Flanges: Factory-fabricated, companion-flange assembly, for 150- or 300-psig minimum working pressure as required to suit system pressures.

- 1. Manufacturers:

- a. Capitol Manufacturing Co.
- b. Central Plastics Company.
- c. Epco Sales, Inc.

- d. Watts Industries, Inc.; Water Products Div.
- E. Dielectric-Flange Kits: Companion-flange assembly for field assembly. Include flanges, full-face- or ring-type neoprene or phenolic gasket, phenolic or polyethylene bolt sleeves, phenolic washers, and steel backing washers.
  - 1. Manufacturers:
    - a. Advance Products & Systems, Inc.
    - b. Calpico, Inc.
    - c. Central Plastics Company.
    - d. Pipeline Seal and Insulator, Inc.
  - 2. Separate companion flanges and steel bolts and nuts shall have 150- or 300-psig minimum working pressure where required to suit system pressures.
- F. Dielectric Couplings: Galvanized-steel coupling with inert and noncorrosive, thermoplastic lining; threaded ends; and 300-psig minimum working pressure at 225 deg F.
  - 1. Manufacturers:
    - a. Calpico, Inc.
    - b. Lochinvar Corp.
- G. Dielectric Nipples: Electroplated steel nipple with inert and noncorrosive, thermoplastic lining; plain, threaded, or grooved ends; and 300-psig minimum working pressure at 225 deg F.
  - 1. Manufacturers:
    - a. Perfection Corp.
    - b. Precision Plumbing Products, Inc.
    - c. Sioux Chief Manufacturing Co., Inc.
    - d. Victaulic Co. of America.

## 2.6 MECHANICAL SLEEVE SEALS

- A. Description: Modular sealing element unit, designed for field assembly, to fill annular space between pipe and sleeve.
  - 1. Manufacturers:
    - a. Advance Products & Systems, Inc.
    - b. Calpico, Inc.
    - c. Metraflex Co.
    - d. Pipeline Seal and Insulator, Inc.
  - 2. Sealing Elements: EPDM interlocking links shaped to fit surface of pipe. Include type and number required for pipe material and size of pipe.
  - 3. Pressure Plates: Stainless steel. Include two for each sealing element.

4. Connecting Bolts and Nuts: Stainless steel of length required to secure pressure plates to sealing elements. Include one for each sealing element.

## 2.7 SLEEVES

- A. Galvanized-Steel Sheet: 0.0239-inch minimum thickness; round tube closed with welded longitudinal joint.
- B. Steel Pipe: ASTM A 53, Type E, Grade B, Schedule 40, galvanized, plain ends.
- C. Cast Iron: Cast or fabricated "wall pipe" equivalent to ductile-iron pressure pipe, with plain ends and integral waterstop, unless otherwise indicated.
- D. Stack Sleeve Fittings: Manufactured, cast-iron sleeve with integral clamping flange. Include clamping ring and bolts and nuts for membrane flashing.
  1. Underdeck Clamp: Clamping ring with set screws.
- E. Molded PE: Reusable, PE, tapered-cup shaped, and smooth-outer surface with nailing flange for attaching to wooden forms.

## 2.8 ESCUTCHEONS

- A. Description: Manufactured wall and ceiling escutcheons and floor plates, with an ID to closely fit around pipe, tube, and insulation of insulated piping and an OD that completely covers opening.
- B. One-Piece, Deep-Pattern Type: Deep-drawn, box-shaped brass with polished chrome-plated finish.
- C. One-Piece, Floor-Plate Type: Cast-iron floor plate.
- D. Split-Casting, Floor-Plate Type: Cast brass with concealed hinge and set screw.

## 2.9 GROUT

- A. Description: ASTM C 1107, Grade B, nonshrink and nonmetallic, dry hydraulic-cement grout.
  1. Characteristics: Post-hardening, volume-adjusting, nonstaining, noncorrosive, nongaseous, and recommended for interior and exterior applications.
  2. Design Mix: 5000-psi, 28-day compressive strength.
  3. Packaging: Premixed and factory packaged.

## 2.10 LINK SEAL

- A. Link-Seal® Modular Seal Pressure Plates

1. Link-Seal® modular seal pressure plates shall be molded of glass reinforced Nylon Polymer with the following properties:
  - a. Izod Impact - Notched = 2.05ft-lb/in. per ASTM D-256  
Flexural Strength @ Yield = 30,750 psi per ASTM D-790  
Flexural Modulus = 1,124,000 psi per ASTM D-790  
Elongation Break = 11.07% per ASTM D-638  
Specific Gravity = 1.38 per ASTM D-792
2. Models LS200-275-300-315 shall incorporate the most current Link-Seal® Modular Seal design modifications and shall include an integrally molded compression assist boss on the top (bolt entry side) of the pressure plate, which permits increased compressive loading of the rubber sealing element. Models 315-325-340-360-400-410-425-475-500-525-575-600 shall incorporate an integral recess known as a "Hex Nut Interlock" designed to accommodate commercially available fasteners to insure proper thread engagement for the class and service of metal hardware. All pressure plates shall have a permanent identification of the manufacturer's name molded into it.
3. For fire and Hi-Temp service, pressure plates shall be steel with 2-part Zinc Dichromate Coating.
4. Link-Seal® Modular Seal Hardware: All fasteners shall be sized according to latest Link-Seal® modular seal technical data. Bolts, flange hex nuts shall be: 316 Stainless Steel per ASTM F593-95, with a 85,000 psi average tensile strength.

### PART 3 - EXECUTION

#### 3.1 PLUMBING DEMOLITION

- A. Refer to Division 01 Section "Cutting and Patching" and Division 02 Section "Selective Structure Demolition" for general demolition requirements and procedures.
- B. Disconnect, demolish, and remove plumbing systems, equipment, and components indicated to be removed.
  1. Piping to Be Removed: Remove portion of piping indicated to be removed and cap or plug remaining piping with same or compatible piping material.
  2. Piping to Be Abandoned in Place: Drain piping and cap or plug piping with same or compatible piping material.
  3. Equipment to Be Removed: Disconnect and cap services and remove equipment.
  4. Equipment to Be Removed and Reinstalled: Disconnect and cap services and remove, clean, and store equipment; when appropriate, reinstall, reconnect, and make equipment operational.
  5. Equipment to Be Removed and Salvaged: Disconnect and cap services and remove equipment and deliver to Owner.
- C. If pipe, insulation, or equipment to remain is damaged in appearance or is unserviceable, remove damaged or unserviceable portions and replace with new products of equal capacity and quality.

### 3.2 SEISMIC REQUIREMENTS

- A. Comply with SEI/ASCE 7 and with requirements for seismic seismic-restraint devices in Section 22 0548 "Vibration and Seismic Controls for Plumbing Piping and Equipment."

### 3.3 PIPING SYSTEMS - COMMON REQUIREMENTS

- A. Install piping according to the following requirements and Division 22 Sections specifying piping systems.
- B. Drawing plans, schematics, and diagrams indicate general location and arrangement of piping systems. Indicated locations and arrangements were used to size pipe and calculate friction loss, expansion, pump sizing, and other design considerations. Install piping as indicated unless deviations to layout are approved on Coordination Drawings.
- C. Install piping in concealed locations, unless otherwise indicated and except in equipment rooms and service areas.
- D. Install piping indicated to be exposed and piping in equipment rooms and service areas at right angles or parallel to building walls. Diagonal runs are prohibited unless specifically indicated otherwise.
- E. Install piping above accessible ceilings to allow sufficient space for ceiling panel removal.
- F. Install piping to permit valve servicing.
- G. Install piping at indicated slopes.
- H. Install piping free of sags and bends.
- I. Install fittings for changes in direction and branch connections.
- J. Install piping to allow application of insulation.
- K. Select system components with pressure rating equal to or greater than system operating pressure.
- L. Install escutcheons for penetrations of walls, ceilings, and floors according to the following:
  - 1. New Piping:
    - a. Piping with Fitting or Sleeve Protruding from Wall: One-piece, deep-pattern type.
    - b. Chrome-Plated Piping: One-piece, cast-brass type with polished chrome-plated finish.
    - c. Insulated Piping: One-piece, stamped-steel type with spring clips.
    - d. Bare Piping at Wall and Floor Penetrations in Finished Spaces: One-piece, cast-brass type with polished chrome-plated finish.



- e. Bare Piping at Wall and Floor Penetrations in Finished Spaces: One-piece, stamped-steel type.
  - f. Bare Piping at Floor Penetrations in Equipment Rooms: One-piece, floor-plate type.
2. Existing Piping: Use the following:
- a. Chrome-Plated Piping: Split-casting, cast-brass type with chrome-plated finish.
  - b. Bare Piping at Wall and Floor Penetrations in Finished Spaces: Split-casting, cast-brass type with chrome-plated finish.
  - c. Bare Piping at Wall and Floor Penetrations in Finished Spaces: Split-plate, stamped-steel type with concealed hinge and spring clips.
  - d. Bare Piping at Ceiling Penetrations in Finished Spaces: Split-casting, cast-brass type with chrome-plated finish.
  - e. Bare Piping at Ceiling Penetrations in Finished Spaces: Split-plate, stamped-steel type with concealed hinge and set screw.
  - f. Bare Piping in Equipment Rooms: Split-casting, cast-brass type.
  - g. Bare Piping in Equipment Rooms: Split-plate, stamped-steel type with set screw or spring clips.
  - h. Bare Piping at Floor Penetrations in Equipment Rooms: Split-casting, floor-plate type.
- M. Sleeves are not required for core-drilled holes.
- N. Permanent sleeves are not required for holes formed by removable PE sleeves.
- O. Install sleeves for pipes passing through concrete and masonry walls and concrete floor and roof slabs.
- P. Install sleeves for pipes passing through concrete and masonry walls, gypsum-board partitions, and concrete floor and roof slabs.
- 1. Cut sleeves to length for mounting flush with both surfaces.
    - a. Exception: Extend sleeves installed in floors of mechanical equipment areas or other wet areas 2 inches above finished floor level. Extend cast-iron sleeve fittings below floor slab as required to secure clamping ring if ring is specified.
  - 2. Install sleeves in new walls and slabs as new walls and slabs are constructed.
  - 3. Install sleeves that are large enough to provide 1/4-inch annular clear space between sleeve and pipe or pipe insulation. Use the following sleeve materials:
    - a. Steel Pipe Sleeves: For pipes smaller than NPS 6.
    - b. Steel Sheet Sleeves: For pipes NPS 6 and larger, penetrating gypsum-board partitions.
    - c. Stack Sleeve Fittings: For pipes penetrating floors with membrane waterproofing. Secure flashing between clamping flanges. Install section of cast-iron soil pipe to extend sleeve to 2 inches above finished floor level. Refer to Division 07 Section "Sheet Metal Flashing and Trim" for flashing.
      - 1) Seal space outside of sleeve fittings with grout.

4. Except for underground wall penetrations, seal annular space between sleeve and pipe or pipe insulation, using joint sealants appropriate for size, depth, and location of joint. Refer to Division 07 Section "Joint Sealants" for materials and installation.
- Q. Aboveground, Exterior-Wall Pipe Penetrations: Seal penetrations using sleeves and mechanical sleeve seals. Select sleeve size to allow for 1-inch annular clear space between pipe and sleeve for installing mechanical sleeve seals.
1. Install steel pipe for sleeves smaller than 6 inches in diameter.
  2. Install cast-iron "wall pipes" for sleeves 6 inches and larger in diameter.
  3. Mechanical Sleeve Seal Installation: Select type and number of sealing elements required for pipe material and size. Position pipe in center of sleeve. Assemble mechanical sleeve seals and install in annular space between pipe and sleeve. Tighten bolts against pressure plates that cause sealing elements to expand and make watertight seal.
- R. Underground, Exterior-Wall Pipe Penetrations: Install cast-iron "wall pipes" for sleeves. Seal pipe penetrations using mechanical sleeve seals. Select sleeve size to allow for 1-inch annular clear space between pipe and sleeve for installing mechanical sleeve seals.
1. Mechanical Sleeve Seal Installation: Select type and number of sealing elements required for pipe material and size. Position pipe in center of sleeve. Assemble mechanical sleeve seals and install in annular space between pipe and sleeve. Tighten bolts against pressure plates that cause sealing elements to expand and make watertight seal.
- S. Fire-Barrier Penetrations: Maintain indicated fire rating of walls, partitions, ceilings, and floors at pipe penetrations. Seal pipe penetrations with firestop materials. Refer to Division 07 Section "Penetration Firestopping" for materials.
- T. Verify final equipment locations for roughing-in.
- U. Refer to equipment specifications in other Sections of these Specifications for roughing-in requirements.

### 3.4 PIPING JOINT CONSTRUCTION

- A. Join pipe and fittings according to the following requirements and Division 22 Sections specifying piping systems.
- B. Ream ends of pipes and tubes and remove burrs. Bevel plain ends of steel pipe.
- C. Remove scale, slag, dirt, and debris from inside and outside of pipe and fittings before assembly.
- D. Soldered Joints: Apply ASTM B 813, water-flushable flux, unless otherwise indicated, to tube end. Construct joints according to ASTM B 828 or CDA's "Copper Tube Handbook," using lead-free solder alloy complying with ASTM B 32.

- E. Brazed Joints: Construct joints according to AWS's "Brazing Handbook," "Pipe and Tube" Chapter, using copper-phosphorus brazing filler metal complying with AWS A5.8.
- F. Threaded Joints: Thread pipe with tapered pipe threads according to ASME B1.20.1. Cut threads full and clean using sharp dies. Ream threaded pipe ends to remove burrs and restore full ID. Join pipe fittings and valves as follows:
  - 1. Apply appropriate tape or thread compound to external pipe threads unless dry seal threading is specified.
  - 2. Damaged Threads: Do not use pipe or pipe fittings with threads that are corroded or damaged. Do not use pipe sections that have cracked or open welds.
- G. Welded Joints: Construct joints according to AWS D10.12, using qualified processes and welding operators according to Part 1 "Quality Assurance" Article.
- H. Flanged Joints: Select appropriate gasket material, size, type, and thickness for service application. Install gasket concentrically positioned. Use suitable lubricants on bolt threads.
- I. PE Piping Heat-Fusion Joints: Clean and dry joining surfaces by wiping with clean cloth or paper towels. Join according to ASTM D 2657.
  - 1. Plain-End Pipe and Fittings: Use butt fusion.
  - 2. Plain-End Pipe and Socket Fittings: Use socket fusion.
- J. Fiberglass Bonded Joints: Prepare pipe ends and fittings, apply adhesive, and join according to pipe manufacturer's written instructions.

### 3.5 PIPING CONNECTIONS

- A. Make connections according to the following, unless otherwise indicated:
  - 1. Install unions, in piping NPS 2 and smaller, adjacent to each valve and at final connection to each piece of equipment.
  - 2. Install flanges, in piping NPS 2-1/2 and larger, adjacent to flanged valves and at final connection to each piece of equipment.
  - 3. Dry Piping Systems: Install dielectric unions and flanges to connect piping materials of dissimilar metals.
  - 4. Wet Piping Systems: Install dielectric coupling and nipple fittings to connect piping materials of dissimilar metals.

### 3.6 EQUIPMENT INSTALLATION - COMMON REQUIREMENTS

- A. Install equipment to allow maximum possible headroom unless specific mounting heights are not indicated.
- B. Install equipment level and plumb, parallel and perpendicular to other building systems and components in exposed interior spaces, unless otherwise indicated.

- C. Install plumbing equipment to facilitate service, maintenance, and repair or replacement of components. Connect equipment for ease of disconnecting, with minimum interference to other installations. Extend grease fittings to accessible locations.
- D. Install equipment to allow right of way for piping installed at required slope.

### 3.7 PAINTING

- A. Painting of plumbing systems, equipment, and components is specified in Division 09 Sections "Interior Painting" and "Exterior Painting."
- B. Damage and Touchup: Repair marred and damaged factory-painted finishes with materials and procedures to match original factory finish.

### 3.8 CONCRETE BASES

- A. Concrete Bases: Anchor equipment to concrete base according to equipment manufacturer's written instructions and according to seismic codes at Project.
  - 1. Construct concrete bases of dimensions indicated, but not less than 4 inches larger in both directions than supported unit.
  - 2. Install dowel rods to connect concrete base to concrete floor. Unless otherwise indicated, install dowel rods on 18-inch centers around the full perimeter of the base.
  - 3. Install epoxy-coated anchor bolts for supported equipment that extend through concrete base, and anchor into structural concrete floor.
  - 4. Place and secure anchorage devices. Use supported equipment manufacturer's setting drawings, templates, diagrams, instructions, and directions furnished with items to be embedded.
  - 5. Install anchor bolts to elevations required for proper attachment to supported equipment.
  - 6. Install anchor bolts according to anchor-bolt manufacturer's written instructions.

### 3.9 ERECTION OF METAL SUPPORTS AND ANCHORAGES

- A. Refer to Division 05 Section "Metal Fabrications" for structural steel.
- B. Cut, fit, and place miscellaneous metal supports accurately in location, alignment, and elevation to support and anchor plumbing materials and equipment.
- C. Field Welding: Comply with AWS D1.1.

### 3.10 ERECTION OF WOOD SUPPORTS AND ANCHORAGES

- A. Cut, fit, and place wood grounds, nailers, blocking, and anchorages to support, and anchor plumbing materials and equipment.

- B. Select fastener sizes that will not penetrate members if opposite side will be exposed to view or will receive finish materials. Tighten connections between members. Install fasteners without splitting wood members.
- C. Attach to substrates as required to support applied loads.

### 3.11 GROUTING

- A. Mix and install grout for plumbing equipment base bearing surfaces, pump and other equipment base plates, and anchors.
- B. Clean surfaces that will come into contact with grout.
- C. Provide forms as required for placement of grout.
- D. Avoid air entrapment during placement of grout.
- E. Place grout, completely filling equipment bases.
- F. Place grout on concrete bases and provide smooth bearing surface for equipment.
- G. Place grout around anchors.
- H. Cure placed grout.

END OF SECTION

**SECTION 22 05 17 - SLEEVES AND SLEEVE SEALS FOR PLUMBING PIPING**

## PART 1 - GENERAL

## 1.1 RELATED DOCUMENTS

- A. Drawings and general provisions of the Contract, including General and Supplementary Conditions and Division 01 Specification Sections, apply to this Section.

## 1.2 SUMMARY

- A. Section Includes:
  - 1. Sleeves.
  - 2. Sleeve-seal systems.
  - 3. Grout.

## 1.3 ACTION SUBMITTALS

- A. Product Data: For each type of product indicated.

## PART 2 - PRODUCTS

## 2.1 SLEEVES

- A. Cast-Iron Wall Pipes: Cast or fabricated of cast or ductile iron and equivalent to ductile-iron pressure pipe, with plain ends and integral waterstop unless otherwise indicated.
- B. Galvanized-Steel Wall Pipes: ASTM A 53, Schedule 40, with plain ends and welded steel collar; zinc coated.
- C. Galvanized-Steel-Pipe Sleeves: ASTM A 53, Type E, Grade B, Schedule 40, zinc coated, with plain ends.
- D. PVC-Pipe Sleeves: ASTM D 1785, Schedule 40.
- E. Galvanized-Steel-Sheet Sleeves: 0.0239-inch minimum thickness; round tube closed with welded longitudinal joint.

## 2.2 SLEEVE-SEAL SYSTEMS

- A. Manufacturers: Subject to compliance with requirements, provide products by one of the following:

1. Advance Products & Systems, Inc.
2. CALPICO, Inc.
3. Link-Seal
4. Metraflex Company (The).
5. Pipeline Seal and Insulator, Inc.
6. Proco Products, Inc.

B. Description: Modular sealing-element unit, designed for field assembly, for filling annular space between piping and sleeve.

1. Sealing Elements: EPDM-rubber interlocking links shaped to fit surface of pipe. Include type and number required for pipe material and size of pipe.
2. Pressure Plates: Carbon steel.
3. Connecting Bolts and Nuts: Carbon steel, with corrosion-resistant coating, of length required to secure pressure plates to sealing elements.

### 2.3 GROUT

- A. Standard: ASTM C 1107, Grade B, post-hardening and volume-adjusting, dry, hydraulic-cement grout.
- B. Characteristics: Nonshrink; recommended for interior and exterior applications.
- C. Design Mix: 5000-psi, 28-day compressive strength.
- D. Packaging: Premixed and factory packaged.

## PART 3 - EXECUTION

### 3.1 SLEEVE INSTALLATION

- A. Install sleeves for piping passing through penetrations in floors, partitions, roofs, and walls.
- B. For sleeves that will have sleeve-seal system installed, select sleeves of size large enough to provide 1-inch annular clear space between piping and concrete slabs and walls.
  1. Sleeves are not required for core-drilled holes.
- C. Install sleeves in concrete floors, concrete roof slabs, and concrete walls as new slabs and walls are constructed.
  1. Permanent sleeves are not required for holes in slabs formed by molded-PE or -PP sleeves.
  2. Cut sleeves to length for mounting flush with both surfaces.
    - a. Exception: Extend sleeves installed in floors of mechanical equipment areas or other wet areas 2 inches above finished floor level.

3. Using grout, seal the space outside of sleeves in slabs and walls without sleeve-seal system.
- D. Install sleeves for pipes passing through interior partitions.
1. Cut sleeves to length for mounting flush with both surfaces.
  2. Install sleeves that are large enough to provide 1/4-inch annular clear space between sleeve and pipe or pipe insulation.
  3. Seal annular space between sleeve and piping or piping insulation; use joint sealants appropriate for size, depth, and location of joint. Comply with requirements for sealants specified in Division 07 Section "Joint Sealants."
- E. Fire-Barrier Penetrations: Maintain indicated fire rating of walls, partitions, ceilings, and floors at pipe penetrations. Seal pipe penetrations with firestop materials. Comply with requirements for firestopping specified in Division 07 Section "Penetration Firestopping."

### 3.2 SLEEVE-SEAL-SYSTEM INSTALLATION

- A. Install sleeve-seal systems in sleeves in exterior concrete walls and slabs-on-grade at service piping entries into building.
- B. Select type, size, and number of sealing elements required for piping material and size and for sleeve ID or hole size. Position piping in center of sleeve. Center piping in penetration, assemble sleeve-seal system components, and install in annular space between piping and sleeve. Tighten bolts against pressure plates that cause sealing elements to expand and make a watertight seal.

### 3.3 SLEEVE AND SLEEVE-SEAL SCHEDULE

- A. Use sleeves and sleeve seals for the following piping-penetration applications:
1. Exterior Concrete Walls above Grade:
    - a. Piping Smaller Than NPS 6: Cast-iron wall sleeves.
    - b. Piping NPS 6 and Larger: Cast-iron wall sleeves.
  2. Exterior Concrete Walls below Grade:
    - a. Piping Smaller Than NPS 6: Cast-iron wall sleeves with sleeve-seal system.
      - 1) Select sleeve size to allow for 1-inch annular clear space between piping and sleeve for installing sleeve-seal system.
    - b. Piping NPS 6 and Larger: Cast-iron wall sleeves with sleeve-seal system.
      - 1) Select sleeve size to allow for 1-inch annular clear space between piping and sleeve for installing sleeve-seal system.
  3. Concrete Slabs-on-Grade:
    - a. Piping Smaller Than NPS 6: Cast-iron wall sleeves with sleeve-seal system.



- 1) Select sleeve size to allow for 1-inch annular clear space between piping and sleeve for installing sleeve-seal system.
- b. Piping NPS 6 and Larger: Cast-iron wall sleeves with sleeve-seal system.
  - 1) Select sleeve size to allow for 1-inch annular clear space between piping and sleeve for installing sleeve-seal system.
4. Concrete Slabs above Grade:
  - a. Piping Smaller Than NPS 6: Galvanized-steel-pipe sleeves.
  - b. Piping NPS 6 and Larger: Galvanized-steel-pipe sleeves.
5. Interior Partitions:
  - a. Piping Smaller Than NPS 6: Galvanized-steel-pipe sleeves.
  - b. Piping NPS 6 and Larger: Galvanized-steel-sheet sleeves.

END OF SECTION

**SECTION 22 05 18 - ESCUTCHEONS FOR PLUMBING PIPING**

## PART 1 - GENERAL

## 1.1 RELATED DOCUMENTS

- A. Drawings and general provisions of the Contract, including General and Supplementary Conditions and Division 01 Specification Sections, apply to this Section.

## 1.2 SUMMARY

- A. Section Includes:
  - 1. Escutcheons.

## 1.3 ACTION SUBMITTALS

- A. Product Data: For each type of product indicated.

## PART 2 - PRODUCTS

## 2.1 ESCUTCHEONS

- A. One-Piece, Cast-Brass Type: With polished, chrome-plated finish and setscrew fastener.
- B. One-Piece, Deep-Pattern Type: Deep-drawn, box-shaped brass with chrome-plated finish and spring-clip fasteners.
- C. One-Piece, Stamped-Steel Type: With chrome-plated finish and spring-clip fasteners.

## PART 3 - EXECUTION

## 3.1 INSTALLATION

- A. Install escutcheons for piping penetrations of walls, ceilings, and finished floors.
- B. Install escutcheons with ID to 2 inch (50mm), tube, and insulation of insulated piping and with OD that completely covers opening.
  - 1. Escutcheons for New Piping:
    - a. Piping with Fitting or Sleeve Protruding from Wall: One-piece, deep-pattern type with polished, chrome-plated finish.

- b. Chrome-Plated Piping: One-piece, cast-brass type with polished, chrome-plated finish.
- c. Insulated Piping: One-piece, stamped-steel type with chrome-plated finish.
- d. Bare Piping 2 inch and Smaller at Wall and Floor Penetrations in Finished Spaces: One-piece, cast-brass type with polished, chrome-plated finish.
- e. Bare Piping Larger than 2 inch at Wall and Floor Penetrations in Finished Spaces: One-piece, stamped-steel type with polished, chrome-plated finish.
- f. Bare Piping 2 inch and Smaller at Ceiling Penetrations in Finished Spaces: One-piece, cast-brass type with polished, chrome-plated finish.
- g. Bare Piping Larger than 2 inch at Ceiling Penetrations in Finished Spaces: One-piece, stamped-steel type with polished, chrome-plated finish.
- h. Bare Piping 2 inch and Smaller in Unfinished Service Spaces: One-piece, cast-brass type with polished, chrome-plated or rough-brass finish.
- i. Bare Piping Larger than 2 inch in Unfinished Service Spaces: One-piece, stamped-steel type with polished, chrome-plated finish.
- j. Bare Piping 2 inch and Smaller in Equipment Rooms: One-piece, cast-brass type with polished, chrome-plated or rough-brass finish.
- k. Bare Piping in Equipment Rooms Larger than 2 inch: One-piece, stamped-steel type with chrome- or cadmium-plated finish.

### 3.2 FIELD QUALITY CONTROL

- A. Replace broken and damaged escutcheons and floor plates using new materials.

END OF SECTION

**SECTION 22 05 23 - GENERAL-DUTY VALVES FOR PLUMBING PIPING**

## PART 1 - GENERAL

## 1.1 RELATED DOCUMENTS

- A. Drawings and general provisions of the Contract, including General and Supplementary Conditions and Division 01 Specification Sections, apply to this Section.

## 1.2 SUMMARY

## A. Section Includes:

1. Bronze angle valves.
2. Bronze ball valves.
3. Iron, single-flange butterfly valves.
4. Bronze lift check valves.
5. Bronze swing check valves.
6. Iron swing check valves.
7. Bronze globe valves.
8. Iron globe valves.

## B. Related Sections:

1. Division 22 plumbing piping Sections for specialty valves applicable to those Sections only.
2. Division 22 Section "Identification for Plumbing Piping and Equipment" for valve tags and schedules.
3. Division 33 water distribution piping Sections for general-duty and specialty valves for site construction piping.

## 1.3 DEFINITIONS

- A. CWP: Cold working pressure.
- B. EPDM: Ethylene propylene copolymer rubber.
- C. NBR: Acrylonitrile-butadiene, Buna-N, or nitrile rubber.
- D. NRS: Nonrising stem.
- E. OS&Y: Outside screw and yoke.
- F. RS: Rising stem.
- G. SWP: Steam working pressure.

#### 1.4 SUBMITTALS

- A. Product Data: For each type of valve indicated.

#### 1.5 QUALITY ASSURANCE

- A. Source Limitations for Valves: Obtain each type of valve from single source from single manufacturer.
- B. ASME Compliance:
  - 1. ASME B16.10 and ASME B16.34 for ferrous valve dimensions and design criteria.
  - 2. ASME B31.1 for power piping valves.
  - 3. ASME B31.9 for building services piping valves.
- C. NSF Compliance: NSF 61 for valve materials for potable-water service.

#### 1.6 DELIVERY, STORAGE, AND HANDLING

- A. Prepare valves for shipping as follows:
  - 1. Protect internal parts against rust and corrosion.
  - 2. Protect threads, flange faces, grooves, and weld ends.
  - 3. Set angle and globe valves closed to prevent rattling.
  - 4. Set ball and plug valves open to minimize exposure of functional surfaces.
  - 5. Set butterfly valves closed or slightly open.
  - 6. Block check valves in either closed or open position.
- B. Use the following precautions during storage:
  - 1. Maintain valve end protection.
  - 2. Store valves indoors and maintain at higher than ambient dew point temperature. If outdoor storage is necessary, store valves off the ground in watertight enclosures.
- C. Use sling to handle large valves; rig sling to avoid damage to exposed parts. Do not use handwheels or stems as lifting or rigging points.

### PART 2 - PRODUCTS

#### 2.1 GENERAL REQUIREMENTS FOR VALVES

- A. Refer to valve schedule articles for applications of valves.
- B. Valve Pressure and Temperature Ratings: Not less than indicated and as required for system pressures and temperatures.
- C. Valve Sizes: Same as upstream piping unless otherwise indicated.

## D. Valve Actuator Types:

1. Gear Actuator: For quarter-turn valves NPS 8 and larger.
2. Handwheel: For valves other than quarter-turn types.
3. Handlever: For quarter-turn valves NPS 6 and smaller except plug valves.
4. Wrench: For plug valves with square heads. Furnish Owner with 1 wrench for every 5 plug valves, for each size square plug-valve head.

## E. Valves in Insulated Piping: With 2-inch stem extensions and the following features:

1. Ball Valves: With extended operating handle of non-thermal-conductive material, and protective sleeve that allows operation of valve without breaking the vapor seal or disturbing insulation.
2. Butterfly Valves: With extended neck.

## F. Valve-End Connections:

1. Flanged: With flanges according to ASME B16.1 for iron valves.
2. Solder Joint: With sockets according to ASME B16.18.
3. Threaded: With threads according to ASME B1.20.1.

## G. Valve Bypass and Drain Connections: MSS SP-45.

## 2.2 BRONZE ANGLE VALVES

## A. Class 125, Bronze Angle Valves with Bronze Disc:

1. Manufacturers: Subject to compliance with requirements, provide products by one of the following:
  - a. Hammond Valve.
  - b. Milwaukee Valve Company.
2. Description:
  - a. Standard: MSS SP-80, Type 1.
  - b. CWP Rating: 200 psig.
  - c. Body Material: ASTM B 62, bronze with integral seat and screw-in bonnet.
  - d. Ends: Threaded.
  - e. Stem and Disc: Bronze.
  - f. Packing: Asbestos free.
  - g. Handwheel: Malleable iron, bronze, or aluminum.

## 2.3 BRONZE BALL VALVES

## A. Two-Piece, Full-Port, Bronze Ball Valves with Bronze Trim:

1. Manufacturers: Subject to compliance with requirements, provide products by one of the following:
  - a. American Valve, Inc.

- b. Conbraco Industries, Inc.; Apollo Valves.
- c. Crane Co.; Crane Valve Group; Crane Valves.
- d. Hammond Valve.
- e. Lance Valves; a division of Advanced Thermal Systems, Inc.
- f. Legend Valve.
- g. Milwaukee Valve Company.
- h. NIBCO INC.
- i. Red-White Valve Corporation.
- j. Watts Regulator Co.; a division of Watts Water Technologies, Inc.

2. Description:

- a. Standard: MSS SP-110.
- b. SWP Rating: 150 psig.
- c. CWP Rating: 600 psig.
- d. Body Design: Two piece.
- e. Body Material: Bronze.
- f. Ends: Threaded.
- g. Seats: PTFE or TFE.
- h. Stem: Bronze.
- i. Ball: Chrome-plated brass.
- j. Port: Full.

B. Two-Piece, Full-Port, Bronze Ball Valves with Stainless-Steel Trim:

1. Manufacturers: Subject to compliance with requirements, provide products by one of the following:

- a. Conbraco Industries, Inc.; Apollo Valves.
- b. Crane Co.; Crane Valve Group; Crane Valves.
- c. Hammond Valve.
- d. Lance Valves; a division of Advanced Thermal Systems, Inc.
- e. Milwaukee Valve Company.
- f. NIBCO INC.
- g. Watts Regulator Co.; a division of Watts Water Technologies, Inc.

2. Description:

- a. Standard: MSS SP-110.
- b. SWP Rating: 150 psig.
- c. CWP Rating: 600 psig.
- d. Body Design: Two piece.
- e. Body Material: Bronze.
- f. Ends: Threaded.
- g. Seats: PTFE or TFE.
- h. Stem: Stainless steel.
- i. Ball: Stainless steel, vented.
- j. Port: Full.

C. Three-Piece, Full-Port, Bronze Ball Valves with Bronze Trim:

1. Manufacturers: Subject to compliance with requirements, provide products by one of the following:

- a. Conbraco Industries, Inc.; Apollo Valves.
- b. DynaQuip Controls.
- c. Hammond Valve.
- d. Milwaukee Valve Company.
- e. NIBCO INC.
- f. Red-White Valve Corporation.

2. Description:

- a. Standard: MSS SP-110.
- b. SWP Rating: 150 psig.
- c. CWP Rating: 600 psig.
- d. Body Design: Three piece.
- e. Body Material: Bronze.
- f. Ends: Threaded.
- g. Seats: PTFE or TFE.
- h. Stem: Bronze.
- i. Ball: Chrome-plated brass.
- j. Port: Full.

D. Three-Piece, Full-Port, Bronze Ball Valves with Stainless-Steel Trim:

1. Manufacturers: Subject to compliance with requirements, provide products by one of the following:

- a. Conbraco Industries, Inc.; Apollo Valves.
- b. Hammond Valve.
- c. Milwaukee Valve Company.
- d. NIBCO INC.

2. Description:

- a. Standard: MSS SP-110.
- b. SWP Rating: 150 psig.
- c. CWP Rating: 600 psig.
- d. Body Design: Three piece.
- e. Body Material: Bronze.
- f. Ends: Threaded.
- g. Seats: PTFE or TFE.
- h. Stem: Stainless steel.
- i. Ball: Stainless steel, vented.
- j. Port: Full.

## 2.4 IRON, SINGLE-FLANGE BUTTERFLY VALVES

A. 200 CWP, Iron, Single-Flange Butterfly Valves with EPDM Seat and Aluminum-Bronze Disc:

1. Manufacturers: Subject to compliance with requirements, provide products by one of the following:

- a. ABZ Valve and Controls; a division of ABZ Manufacturing, Inc.



- b. Conbraco Industries, Inc.; Apollo Valves.
- c. Cooper Cameron Valves; a division of Cooper Cameron Corporation.
- d. Crane Co.; Crane Valve Group; Jenkins Valves.
- e. Crane Co.; Crane Valve Group; Stockham Division.
- f. DeZurik Water Controls.
- g. Flo Fab Inc.
- h. Hammond Valve.
- i. Kitz Corporation.
- j. Legend Valve.
- k. Milwaukee Valve Company.
- l. NIBCO INC.
- m. Norrisedal; a Dover Corporation company.
- n. Red-White Valve Corporation.
- o. Spence Strainers International; a division of CIRCOR International, Inc.
- p. Watts Regulator Co.; a division of Watts Water Technologies, Inc.

2. Description:

- a. Standard: MSS SP-67, Type I.
- b. CWP Rating: 200 psig.
- c. Body Design: Lug type; suitable for bidirectional dead-end service at rated pressure without use of downstream flange.
- d. Body Material: ASTM A 126, cast iron or ASTM A 536, ductile iron.
- e. Seat: EPDM.
- f. Stem: One- or two-piece stainless steel.
- g. Disc: Aluminum bronze.

B. 200 CWP, Iron, Single-Flange Butterfly Valves with EPDM Seat and Ductile-Iron Disc:

1. Manufacturers: Subject to compliance with requirements, provide products by one of the following:

- a. ABZ Valve and Controls; a division of ABZ Manufacturing, Inc.
- b. American Valve, Inc.
- c. Conbraco Industries, Inc.; Apollo Valves.
- d. Cooper Cameron Valves; a division of Cooper Cameron Corporation.
- e. Crane Co.; Crane Valve Group; Center Line.
- f. Crane Co.; Crane Valve Group; Stockham Division.
- g. DeZurik Water Controls.
- h. Flo Fab Inc.
- i. Hammond Valve.
- j. Kitz Corporation.
- k. Legend Valve.
- l. Milwaukee Valve Company.
- m. Mueller Steam Specialty; a division of SPX Corporation.
- n. NIBCO INC.
- o. Norrisedal; a Dover Corporation company.
- p. Spence Strainers International; a division of CIRCOR International, Inc.
- q. Sure Flow Equipment Inc.
- r. Watts Regulator Co.; a division of Watts Water Technologies, Inc.

2. Description:

- a. Standard: MSS SP-67, Type I.
- b. CWP Rating: 200 psig.
- c. Body Design: Lug type; suitable for bidirectional dead-end service at rated pressure without use of downstream flange.
- d. Body Material: ASTM A 126, cast iron or ASTM A 536, ductile iron.
- e. Seat: EPDM.
- f. Stem: One- or two-piece stainless steel.
- g. Disc: Nickel-plated or -coated ductile iron.

C. 200 CWP, Iron, Single-Flange Butterfly Valves with EPDM Seat and Stainless-Steel Disc:

1. Manufacturers: Subject to compliance with requirements, provide products by one of the:

- a. ABZ Valve and Controls; a division of ABZ Manufacturing, Inc.
- b. American Valve, Inc.
- c. Conbraco Industries, Inc.; Apollo Valves.
- d. Cooper Cameron Valves; a division of Cooper Cameron Corporation.
- e. Crane Co.; Crane Valve Group; Jenkins Valves.
- f. Crane Co.; Crane Valve Group; Stockham Division.
- g. DeZurik Water Controls.
- h. Flo Fab Inc.
- i. Hammond Valve.
- j. Kitz Corporation.
- k. Legend Valve.
- l. Milwaukee Valve Company.
- m. Mueller Steam Specialty; a division of SPX Corporation.
- n. NIBCO INC.
- o. Norriseal; a Dover Corporation company.
- p. Red-White Valve Corporation.
- q. Spence Strainers International; a division of CIRCOR International, Inc.
- r. Sure Flow Equipment Inc.
- s. Watts Regulator Co.; a division of Watts Water Technologies, Inc.

2. Description:

- a. Standard: MSS SP-67, Type I.
- b. CWP Rating: 200 psig.
- c. Body Design: Lug type; suitable for bidirectional dead-end service at rated pressure without use of downstream flange.
- d. Body Material: ASTM A 126, cast iron or ASTM A 536, ductile iron.
- e. Seat: EPDM.
- f. Stem: One- or two-piece stainless steel.
- g. Disc: Stainless steel.

## 2.5 BRONZE LIFT CHECK VALVES

A. Class 125, Lift Check Valves with Bronze Disc:

1. Manufacturers: Subject to compliance with requirements, provide products by one of the following:

- a. Crane Co.; Crane Valve Group; Crane Valves.
- b. Crane Co.; Crane Valve Group; Jenkins Valves.
- c. Crane Co.; Crane Valve Group; Stockham Division.

2. Description:

- a. Standard: MSS SP-80, Type 1.
- b. CWP Rating: 200 psig.
- c. Body Design: Vertical flow.
- d. Body Material: ASTM B 61 or ASTM B 62, bronze.
- e. Ends: Threaded.
- f. Disc: Bronze.

## 2.6 BRONZE SWING CHECK VALVES

### A. Class 125, Bronze Swing Check Valves with Bronze Disc:

1. Manufacturers: Subject to compliance with requirements, provide products by one of the following:

- a. American Valve, Inc.
- b. Crane Co.; Crane Valve Group; Crane Valves.
- c. Crane Co.; Crane Valve Group; Jenkins Valves.
- d. Crane Co.; Crane Valve Group; Stockham Division.
- e. Hammond Valve.
- f. Kitz Corporation.
- g. Milwaukee Valve Company.
- h. NIBCO INC.
- i. Powell Valves.
- j. Red-White Valve Corporation.
- k. Watts Regulator Co.; a division of Watts Water Technologies, Inc.
- l. Zy-Tech Global Industries, Inc.

2. Description:

- a. Standard: MSS SP-80, Type 3.
- b. CWP Rating: 200 psig.
- c. Body Design: Horizontal flow.
- d. Body Material: ASTM B 62, bronze.
- e. Ends: Threaded.
- f. Disc: Bronze.

### B. Class 150, Bronze Swing Check Valves with Bronze Disc:

1. Manufacturers: Subject to compliance with requirements, provide products by one of the following:

- a. American Valve, Inc.
- b. Crane Co.; Crane Valve Group; Crane Valves.
- c. Crane Co.; Crane Valve Group; Jenkins Valves.
- d. Crane Co.; Crane Valve Group; Stockham Division.
- e. Kitz Corporation.

- f. Milwaukee Valve Company.
- g. NIBCO INC.
- h. Red-White Valve Corporation.
- i. Zy-Tech Global Industries, Inc.

2. Description:

- a. Standard: MSS SP-80, Type 3.
- b. CWP Rating: 300 psig.
- c. Body Design: Horizontal flow.
- d. Body Material: ASTM B 62, bronze.
- e. Ends: Threaded.
- f. Disc: Bronze.

## 2.7 IRON SWING CHECK VALVES

### A. Class 125, Iron Swing Check Valves with Metal Seats:

1. Manufacturers: Subject to compliance with requirements, provide products by one of the following:
  - a. Crane Co.; Crane Valve Group; Crane Valves.
  - b. Crane Co.; Crane Valve Group; Jenkins Valves.
  - c. Crane Co.; Crane Valve Group; Stockham Division.
  - d. Hammond Valve.
  - e. Kitz Corporation.
  - f. Legend Valve.
  - g. Milwaukee Valve Company.
  - h. NIBCO INC.
  - i. Powell Valves.
  - j. Red-White Valve Corporation.
  - k. Sure Flow Equipment Inc.
  - l. Watts Regulator Co.; a division of Watts Water Technologies, Inc.
  - m. Zy-Tech Global Industries, Inc.

2. Description:

- a. Standard: MSS SP-71, Type I.
- b. CWP Rating: 200 psig.
- c. Body Design: Clear or full waterway.
- d. Body Material: ASTM A 126, gray iron with bolted bonnet.
- e. Ends: Flanged.
- f. Trim: Bronze.
- g. Gasket: Asbestos free.

### B. Class 250, Iron Swing Check Valves with Metal Seats:

1. Manufacturers: Subject to compliance with requirements, provide products by one of the following:
  - a. Crane Co.; Crane Valve Group; Crane Valves.
  - b. Crane Co.; Crane Valve Group; Jenkins Valves.

- c. Crane Co.; Crane Valve Group; Stockham Division.
- d. Hammond Valve.
- e. Milwaukee Valve Company.
- f. NIBCO INC.
- g. Watts Regulator Co.; a division of Watts Water Technologies, Inc.

2. Description:

- a. Standard: MSS SP-71, Type I.
- b. CWP Rating: 500 psig.
- c. Body Design: Clear or full waterway.
- d. Body Material: ASTM A 126, gray iron with bolted bonnet.
- e. Ends: Flanged.
- f. Trim: Bronze.
- g. Gasket: Asbestos free.

## 2.8 BRONZE GLOBE VALVES

### A. Class 125, Bronze Globe Valves with Bronze Disc:

1. Manufacturers: Subject to compliance with requirements, provide products by one of the following:

- a. Crane Co.; Crane Valve Group; Crane Valves.
- b. Crane Co.; Crane Valve Group; Stockham Division.
- c. Hammond Valve.
- d. Kitz Corporation.
- e. Milwaukee Valve Company.
- f. NIBCO INC.
- g. Powell Valves.
- h. Red-White Valve Corporation.
- i. Watts Regulator Co.; a division of Watts Water Technologies, Inc.
- j. Zy-Tech Global Industries, Inc.

2. Description:

- a. Standard: MSS SP-80, Type 1.
- b. CWP Rating: 200 psig.
- c. Body Material: ASTM B 62, bronze with integral seat and screw-in bonnet.
- d. Ends: Threaded or solder joint.
- e. Stem and Disc: Bronze.
- f. Packing: Asbestos free.
- g. Handwheel: Malleable iron, bronze, or aluminum.

## 2.9 IRON GLOBE VALVES

### A. Class 125, Iron Globe Valves:

1. Manufacturers: Subject to compliance with requirements, provide products by one of the following:

- a. Crane Co.; Crane Valve Group; Crane Valves.
- b. Crane Co.; Crane Valve Group; Jenkins Valves.
- c. Crane Co.; Crane Valve Group; Stockham Division.
- d. Hammond Valve.
- e. Kitz Corporation.
- f. Milwaukee Valve Company.
- g. NIBCO INC.
- h. Powell Valves.
- i. Red-White Valve Corporation.
- j. Watts Regulator Co.; a division of Watts Water Technologies, Inc.
- k. Zy-Tech Global Industries, Inc.

2. Description:

- a. Standard: MSS SP-85, Type I.
- b. CWP Rating: 200 psig.
- c. Body Material: ASTM A 126, gray iron with bolted bonnet.
- d. Ends: Flanged.
- e. Trim: Bronze.
- f. Packing and Gasket: Asbestos free.

B. Class 250, Iron Globe Valves:

1. Manufacturers: Subject to compliance with requirements, provide products by one of the following:

- a. Crane Co.; Crane Valve Group; Crane Valves.
- b. Crane Co.; Crane Valve Group; Jenkins Valves.
- c. Crane Co.; Crane Valve Group; Stockham Division.
- d. Hammond Valve.
- e. Milwaukee Valve Company.
- f. NIBCO INC.
- g. Watts Regulator Co.; a division of Watts Water Technologies, Inc.

2. Description:

- a. Standard: MSS SP-85, Type I.
- b. CWP Rating: 500 psig.
- c. Body Material: ASTM A 126, gray iron with bolted bonnet.
- d. Ends: Flanged.
- e. Trim: Bronze.
- f. Packing and Gasket: Asbestos free.

## PART 3 - EXECUTION

### 3.1 EXAMINATION

- A. Examine valve interior for cleanliness, freedom from foreign matter, and corrosion. Remove special packing materials, such as blocks, used to prevent disc movement during shipping and handling.

- B. Operate valves in positions from fully open to fully closed. Examine guides and seats made accessible by such operations.
- C. Examine threads on valve and mating pipe for form and cleanliness.
- D. Examine mating flange faces for conditions that might cause leakage. Check bolting for proper size, length, and material. Verify that gasket is of proper size, that its material composition is suitable for service, and that it is free from defects and damage.
- E. Do not attempt to repair defective valves; replace with new valves.

### 3.2 VALVE INSTALLATION

- A. Install valves with unions or flanges at each piece of equipment arranged to allow service, maintenance, and equipment removal without system shutdown.
- B. Locate valves for easy access and provide separate support where necessary.
- C. Install valves in horizontal piping with stem at or above center of pipe.
- D. Install valves in position to allow full stem movement.
- E. Install check valves for proper direction of flow and as follows:
  - 1. Swing Check Valves: In horizontal position with hinge pin level.
  - 2. Lift Check Valves: With stem upright and plumb.

### 3.3 ADJUSTING

- A. Adjust or replace valve packing after piping systems have been tested and put into service but before final adjusting and balancing. Replace valves if persistent leaking occurs.

### 3.4 GENERAL REQUIREMENTS FOR VALVE APPLICATIONS

- A. If valve applications are not indicated, use the following:
  - 1. Shutoff Service: Ball or butterfly valves.
  - 2. Butterfly Valve Dead-End Service: Single-flange (lug) type.
  - 3. Throttling Service Globe, angle, ball or butterfly valves.
  - 4. Pump-Discharge Check Valves:
    - a. NPS 2 and Smaller: Bronze swing check valves with bronze disc.
    - b. NPS 2-1/2 and Larger for Domestic Water: Iron swing check valves with lever and weight check valves.
    - c. NPS 2-1/2 and Larger for Sanitary Waste and Storm Drainage: Iron swing check valves with lever and weight or spring.

- B. If valves with specified SWP classes or CWP ratings are not available, the same types of valves with higher SWP classes or CWP ratings may be substituted.
- C. Select valves, except wafer types, with the following end connections:
  - 1. For Copper Tubing, NPS 2 and Smaller: Threaded ends except where solder-joint valve-end option is indicated in valve schedules below.
  - 2. For Copper Tubing, NPS 2-1/2 to NPS 4: Flanged ends except where threaded valve-end option is indicated in valve schedules below.
  - 3. For Copper Tubing, NPS 5 and Larger: Flanged ends.
  - 4. For Steel Piping, NPS 2 and Smaller: Threaded ends.
  - 5. For Steel Piping, NPS 2-1/2 to NPS 4: Flanged ends except where threaded valve-end option is indicated in valve schedules below.
  - 6. For Steel Piping, NPS 5 and Larger: Flanged ends.

### 3.5 DOMESTIC, HOT- AND COLD-WATER VALVE SCHEDULE

#### A. Pipe NPS 2 and Smaller:

- 1. Bronze Valves: May be provided with solder-joint ends instead of threaded ends.
- 2. Bronze Angle Valves: Class 125 or Class 150, bronze disc.
- 3. Ball Valves: One, Two or Three piece, full or, regular port, bronze with bronze or stainless-steel trim.
- 4. Bronze Swing Check Valves: Class 125 or Class 150, bronze disc.
- 5. Bronze Globe Valves: Class 125 or Class 150, bronze disc.

#### B. Pipe NPS 2-1/2 and Larger:

- 1. Iron Valves, NPS 2-1/2 to NPS 4: May be provided with threaded ends instead of flanged ends.
- 2. Ball Valves: One, Two or Three piece, full or, regular port, bronze with bronze or stainless-steel trim.
- 3. Iron, Single-Flange Butterfly Valves: 200 CWP, EPDM seat, aluminum-bronze, ductile-iron or stainless-steel disc.
- 4. Iron Swing Check Valves: Class 125 or Class 250, metal seats.
- 5. Iron Globe Valves: Class 125 or Class 250.

END OF SECTION



**SECTION 22 05 48 - VIBRATION AND SEISMIC CONTROLS FOR PLUMBING PIPING AND EQUIPMENT**

PART 1 - GENERAL

1.1 RELATED DOCUMENTS

- A. Drawings and general provisions of the Contract, including General and Supplementary Conditions and Division 01 Specification Sections, apply to this Section.

1.2 SUMMARY

- A. This Section includes the following restraints and vibration isolation as defined in Section 23 0548 "Vibration Isolation and Seismic Controls for HVAC" for the following:
  - 1. Plumbing Piping.
  - 2. Plumbing Equipment.

PART 2 - PRODUCTS

2.1 (NOT USED)

PART 3 - EXECUTION

3.1 (NOT USED)

END OF SECTION

**SECTION 22 05 53 - IDENTIFICATION FOR PLUMBING PIPING AND EQUIPMENT**

## PART 1 - GENERAL

## 1.1 RELATED DOCUMENTS

- A. Drawings and general provisions of the Contract, including General and Supplementary Conditions and Division 01 Specification Sections, apply to this Section.

## 1.2 SUMMARY

## A. Section Includes:

1. Equipment labels.
2. Warning signs and labels.
3. Pipe labels.
4. Stencils.
5. Valve tags.
6. Warning tags.

## 1.3 SUBMITTALS

- A. Product Data: For each type of product indicated.
- B. Samples: For color, letter style, and graphic representation required for each identification material and device.
- C. Equipment Label Schedule: Include a listing of all equipment to be labeled with the proposed content for each label.
- D. Valve numbering scheme.
- E. Valve Schedules: For each piping system to include in maintenance manuals.

## 1.4 COORDINATION

- A. Coordinate installation of identifying devices with completion of covering and painting of surfaces where devices are to be applied.
- B. Coordinate installation of identifying devices with locations of access panels and doors.
- C. Install identifying devices before installing acoustical ceilings and similar concealment.

## PART 2 - PRODUCTS

## 2.1 EQUIPMENT LABELS

## A. Plastic Labels for Equipment:

1. Material and Thickness: Multilayer, multicolor, plastic labels for mechanical engraving, 1/16 inch thick, and having predrilled holes for attachment hardware.
2. Letter Color: White.
3. Background Color: Blue.
4. Maximum Temperature: Able to withstand temperatures up to 160 deg F.
5. Minimum Label Size: Length and width vary for required label content, but not less than 2-1/2 by 3/4 inch.
6. Minimum Letter Size: 1/4 inch for name of units if viewing distance is less than 24 inches, 1/2 inch for viewing distances up to 72 inches, and proportionately larger lettering for greater viewing distances. Include secondary lettering two-thirds to three-fourths the size of principal lettering.
7. Fasteners: Stainless-steel rivets or self-tapping screws.
8. Adhesive: Contact-type permanent adhesive, compatible with label and with substrate.

B. Label Content: Include equipment's Drawing designation or unique equipment number, Drawing numbers where equipment is indicated (plans, details, and schedules), plus the Specification Section number and title where equipment is specified.

C. Equipment Label Schedule: For each item of equipment to be labeled, on 8-1/2-by-11-inch bond paper. Tabulate equipment identification number and identify Drawing numbers where equipment is indicated (plans, details, and schedules), plus the Specification Section number and title where equipment is specified. Equipment schedule shall be included in operation and maintenance data.

## 2.2 WARNING SIGNS AND LABELS

A. Material and Thickness: Multilayer, multicolor, plastic labels for mechanical engraving, 1/16 inch thick, and having predrilled holes for attachment hardware.

B. Letter Color: Black.

C. Background Color: Yellow.

D. Maximum Temperature: Able to withstand temperatures up to 160 deg F.

E. Minimum Label Size: Length and width vary for required label content, but not less than 2-1/2 by 3/4 inch.

F. Minimum Letter Size: 1/4 inch for name of units if viewing distance is less than 24 inches, 1/2 inch for viewing distances up to 72 inches, and proportionately larger lettering for greater viewing distances. Include secondary lettering two-thirds to three-fourths the size of principal lettering.

- G. Fasteners: Stainless-steel rivets or self-tapping screws.
- H. Adhesive: Contact-type permanent adhesive, compatible with label and with substrate.
- I. Label Content: Include caution and warning information, plus emergency notification instructions.

## 2.3 PIPE LABELS

- A. General Requirements for Manufactured Pipe Labels: Preprinted, color-coded, with lettering indicating service, and showing flow direction.
- B. Pretensioned Pipe Labels: Precoiled, semirigid plastic formed to cover full circumference of pipe and to attach to pipe without fasteners or adhesive.
- C. Self-Adhesive Pipe Labels: Printed plastic with contact-type, permanent-adhesive backing.
- D. Pipe Label Contents: Include identification of piping service using same designations or abbreviations as used on Drawings, pipe size, and an arrow indicating flow direction.
  - 1. Flow-Direction Arrows: Integral with piping system service lettering to accommodate both directions, or as separate unit on each pipe label to indicate flow direction.
  - 2. Lettering Size: At least 1-1/2 inches high.

## 2.4 STENCILS

- A. Stencils: Prepared with letter sizes according to ASME A13.1 for piping; and minimum letter height of 3/4 inch for access panel and door labels, equipment labels, and similar operational instructions.
  - 1. Stencil Material: Fiberboard or metal.
  - 2. Stencil Paint: Exterior, gloss, alkyd enamel black unless otherwise indicated. Paint may be in pressurized spray-can form.
  - 3. Identification Paint: Exterior, alkyd enamel in colors according to ASME A13.1 unless otherwise indicated.

## 2.5 VALVE TAGS

- A. Valve Tags: Stamped or engraved with 1/4-inch letters for piping system abbreviation and 1/2-inch numbers.
  - 1. Tag Material: Brass, 0.032-inch minimum thickness, and having predrilled or stamped holes for attachment hardware.
  - 2. Fasteners: Brass wire-link or beaded chain; or S-hook.

- B. Valve Schedules: For each piping system, on 8-1/2-by-11-inch bond paper. Tabulate valve number, piping system, system abbreviation (as shown on valve tag), location of valve (room or space), normal-operating position (open, closed, or modulating), and variations for identification. Mark valves for emergency shutoff and similar special uses.

1. Valve-tag schedule shall be included in operation and maintenance data.

## 2.6 WARNING TAGS

- A. Warning Tags: Preprinted or partially preprinted, accident-prevention tags, of plasticized card stock with matte finish suitable for writing.

1. Size: 3 by 5-1/4 inches minimum.
2. Fasteners: Brass grommet and wire.
3. Nomenclature: Large-size primary caption such as "DANGER," "CAUTION," or "DO NOT OPERATE."
4. Color: Yellow background with black lettering.

## PART 3 - EXECUTION

### 3.1 PREPARATION

- A. Clean piping and equipment surfaces of substances that could impair bond of identification devices, including dirt, oil, grease, release agents, and incompatible primers, paints, and encapsulants.

### 3.2 EQUIPMENT LABEL INSTALLATION

- A. Install or permanently fasten labels on each major item of mechanical equipment.
- B. Locate equipment labels where accessible and visible.

### 3.3 PIPE LABEL INSTALLATION

- A. Piping Color-Coding: Painting of piping is specified in Division 09.
- B. Stenciled Pipe Label Option: Stenciled labels may be provided instead of manufactured pipe labels, at Installer's option. Install stenciled pipe labels, complying with ASME A13.1, on each piping system.
1. Identification Paint: Use for contrasting background.
  2. Stencil Paint: Use for pipe marking.
- C. Locate pipe labels where piping is exposed or above accessible ceilings in finished spaces; machine rooms; accessible maintenance spaces such as shafts, tunnels, and plenums; and exterior exposed locations as follows:

1. Near each valve and control device.
2. Near each branch connection, excluding short takeoffs for fixtures and terminal units. Where flow pattern is not obvious, mark each pipe at branch.
3. Near penetrations through walls, floors, ceilings, and inaccessible enclosures.
4. At access doors, manholes, and similar access points that permit view of concealed piping.
5. Near major equipment items and other points of origination and termination.
6. Spaced at maximum intervals of 50 feet along each run. Reduce intervals to 25 feet in areas of congested piping and equipment.
7. On piping above removable acoustical ceilings. Omit intermediately spaced labels.

D. Pipe Label Color Schedule:

1. Low-Pressure, Compressed-Air Piping:
  - a. Background Color: Comply with ASME A13.1.
  - b. Letter Color: Comply with ASME A13.1.
2. Medium-Pressure, Compressed-Air Piping:
  - a. Background Color: Comply with ASME A13.1.
  - b. Letter Color: Comply with ASME A13.1.
3. Domestic Water Piping:
  - a. Background Color: Comply with ASME A13.1.
  - b. Letter Color: Comply with ASME A13.1.
4. Sanitary Waste and Storm Drainage Piping:
  - a. Background Color: Comply with ASME A13.1.
  - b. Letter Color: Comply with ASME A13.1.

### 3.4 VALVE-TAG INSTALLATION

- A. Install tags on valves and control devices in piping systems, except check valves; valves within factory-fabricated equipment units; shutoff valves; faucets; convenience and lawn-watering hose connections; and similar roughing-in connections of end-use fixtures and units. List tagged valves in a valve schedule.
- B. Valve-Tag Application Schedule: Tag valves according to size, shape, and color scheme and with captions similar to those indicated in the following subparagraphs:
  1. Valve-Tag Size and Shape:
    - a. Cold Water: 1-1/2 inches, round.
    - b. Hot Water: 1-1/2 inches, round.
    - c. Low-Pressure Compressed Air: 1-1/2 inches, round.
    - d. High-Pressure Compressed Air: 1-1/2 inches, round.
  2. Valve-Tag Color:

- a. Cold Water: Comply with ASME A13.1.
- b. Hot Water: Comply with ASME A13.1.
- c. Low-Pressure Compressed Air: Comply with ASME A13.1.
- d. High-Pressure Compressed Air: Comply with ASME A13.1.

3. Letter Color:

- a. Cold Water: Comply with ASME A13.1.
- b. Hot Water: Comply with ASME A13.1.
- c. Low-Pressure Compressed Air: Comply with ASME A13.1.
- d. High-Pressure Compressed Air: Comply with ASME A13.1.

3.5 WARNING-TAG INSTALLATION

- A. Write required message on, and attach warning tags to, equipment and other items where required.

END OF SECTION

**SECTION 22 07 19 - PLUMBING PIPING INSULATION**

## PART 1 - GENERAL

## 1.1 RELATED DOCUMENTS

- A. Drawings and general provisions of the Contract, including General and Supplementary Conditions and Division 01 Specification Sections, apply to this Section.

## 1.2 SUMMARY

- A. Section includes insulating the following plumbing piping services:
  - 1. Domestic cold-water piping.
  - 2. Domestic hot-water piping.
  - 3. Domestic recirculating hot-water piping.
  - 4. Supplies and drains for handicap-accessible lavatories and sinks.

## 1.3 DEFINITIONS:

- A. Refer to Section 22 0500 "Common Work Results for Plumbing".

## 1.4 ACTION SUBMITTALS

- A. Product Data: For each type of product indicated. Include thermal conductivity, water-vapor permeance thickness, and jackets (both factory- and field-applied, if any).
- B. Shop Drawings: Include plans, elevations, sections, details, and attachments to other work.
  - 1. Detail application of protective shields, saddles, and inserts at hangers for each type of insulation and hanger.
  - 2. Detail attachment and covering of heat tracing inside insulation.
  - 3. Detail insulation application at pipe expansion joints for each type of insulation.
  - 4. Detail insulation application at elbows, fittings, flanges, valves, and specialties for each type of insulation.
  - 5. Detail removable insulation at piping specialties, equipment connections, and access panels.
  - 6. Detail application of field-applied jackets.
  - 7. Detail application at linkages of control devices.

## 1.5 INFORMATIONAL SUBMITTALS

- A. Qualification Data: For qualified Installer.



- B. Material Test Reports: From a qualified testing agency acceptable to authorities having jurisdiction indicating, interpreting, and certifying test results for compliance of insulation materials, sealers, attachments, cements, and jackets, with requirements indicated. Include dates of tests and test methods employed.

#### 1.6 QUALITY ASSURANCE

- A. Installer Qualifications: Skilled mechanics who have successfully completed an apprenticeship program or another craft training program certified by the Department of Labor, Bureau of Apprenticeship and Training.
- B. Surface-Burning Characteristics: For insulation and related materials, as determined by testing identical products according to ASTM E 84 by a testing agency acceptable to authorities having jurisdiction. Factory label insulation and jacket materials and adhesive, mastic, tapes, and cement material containers, with appropriate markings of applicable testing agency.
  - 1. Insulation Installed Indoors: Flame-spread index of 25 or less, and smoke-developed index of 50 or less.
  - 2. Insulation Installed Outdoors: Flame-spread index of 75 or less, and smoke-developed index of 150 or less.

#### 1.7 DELIVERY, STORAGE, AND HANDLING

- A. Packaging: Insulation material containers shall be marked by manufacturer with appropriate ASTM standard designation, type and grade, and maximum use temperature.

#### 1.8 COORDINATION

- A. Coordinate sizes and locations of supports, hangers, and insulation shields specified in Section 22 0529 "Hangers and Supports for Plumbing Piping and Equipment."
- B. Coordinate clearance requirements with piping Installer for piping insulation application. Before preparing piping Shop Drawings establish and maintain clearance requirements for installation of insulation and field-applied jackets and finishes and for space required for maintenance.

#### 1.9 SCHEDULING

- A. Schedule insulation application after pressure testing systems and, where required, after installing and testing heat tracing. Insulation application may begin on segments that have satisfactory test results.
- B. Complete installation and concealment of plastic materials as rapidly as possible in each area of construction.

## PART 2 - PRODUCTS

## 2.1 INSULATION MATERIALS

- A. Comply with requirements in "Piping Insulation Schedule, General," "Indoor Piping Insulation Schedule," "Outdoor, Aboveground Piping Insulation Schedule," and "Outdoor, Underground Piping Insulation Schedule" articles for where insulating materials shall be applied.
- B. Insulation for below-ambient service requires a vapor-barrier.
- C. Products shall not contain asbestos, lead, mercury, or mercury compounds.
- D. Products that come in contact with stainless steel shall have a leachable chloride content of less than 50 ppm when tested according to ASTM C 871.
- E. Insulation materials for use on austenitic stainless steel shall be qualified as acceptable according to ASTM C 795.
- F. Foam insulation materials shall not use CFC or HCFC blowing agents in the manufacturing process.
- G. Flexible Elastomeric Insulation: Closed-cell, sponge- or expanded-rubber materials. Comply with ASTM C 534, Type I for tubular materials.
  - 1. Products: Subject to compliance with requirements, provide one of the following:
    - a. Aeroflex USA, Inc.; Aerocel.
    - b. Armacell LLC; AP Armaflex.
    - c. K-Flex USA; Insul-Lock, Insul-Tube, and K-FLEX LS.
- H. Mineral-Fiber Blanket Insulation: Mineral or glass fibers bonded with a thermosetting resin. Comply with ASTM C 553:
  - 1. Type II and ASTM C 1290, Factory-applied jacket requirements are specified in "Factory-Applied Jackets" Article.
  - 2. Products: Subject to compliance with requirements, provide one of the following:
    - a. CertainTeed Corp.; SoftTouch Duct Wrap.
    - b. Johns Manville; Microlite.
    - c. Knauf Insulation; Friendly Feel Duct Wrap.
    - d. Manson Insulation Inc.; Alley Wrap.
    - e. Owens Corning; SOFTR All-Service Duct Wrap.
- I. Mineral-Fiber, Preformed Pipe Insulation:
  - 1. Products: Subject to compliance with requirements, provide one of the following:
    - a. Fibrex Insulations Inc.; Coreplus 1200.
    - b. Johns Manville; Micro-Lok.
    - c. Knauf Insulation; 1000-Degree Pipe Insulation.
    - d. Manson Insulation Inc.; Alley-K.

- e. Owens Corning; Fiberglas Pipe Insulation.
- 2. Type I, 850 Deg F Materials: Mineral or glass fibers bonded with a thermosetting resin. Comply with ASTM C 547, Type I, Grade A,
  - a. Without factory-applied jacket with factory-applied ASJ-SSL. Factory-applied jacket requirements are specified in "Factory-Applied Jackets" Article.
- J. Prefabricated Thermal Insulating Fitting Covers: Comply with ASTM C 450 for dimensions used in preforming insulation to cover valves, elbows, tees, and flanges.

## 2.2 INSULATING CEMENTS

- A. Mineral-Fiber Insulating Cement: Comply with ASTM C 195.
  - 1. Products: Subject to compliance with requirements, provide the following:
    - a. Ramco Insulation, Inc.; Super-Stik.
- B. Mineral-Fiber, Hydraulic-Setting Insulating and Finishing Cement: Comply with ASTM C 449.
  - 1. Products: Subject to compliance with requirements, provide the following:
    - a. Ramco Insulation, Inc.; Ramcote 1200 and Quik-Cote.

## 2.3 ADHESIVES

- A. Materials shall be compatible with insulation materials, jackets, and substrates and for bonding insulation to itself and to surfaces to be insulated, unless otherwise indicated.
- B. Flexible Elastomeric Adhesive: Comply with MIL-A-24179A, Type II, Class I.
  - 1. Products: Subject to compliance with requirements, provide one of the following:
    - a. Aeroflex USA, Inc.; Aeroseal.
    - b. Armacell LLC; Armaflex 520 Adhesive.
    - c. Foster Brand, Specialty Construction Brands, Inc., a business of H. B. Fuller Company; 85-75.
    - d. K-Flex USA; R-373 Contact Adhesive.
  - 2. For indoor applications, adhesive shall have a VOC content of 50 g/L or less when calculated according to 40 CFR 59, Subpart D (EPA Method 24).
- C. Mineral-Fiber Adhesive: Comply with MIL-A-3316C, Class 2, Grade A.
  - 1. Products: Subject to compliance with requirements, provide one of the following:
    - a. Childers Brand, Specialty Construction Brands, Inc., a business of H. B. Fuller Company; CP-127.
    - b. Eagle Bridges - Marathon Industries; 225.

- c. Foster Brand, Specialty Construction Brands, Inc., a business of H. B. Fuller Company; 85-60/85-70.
    - d. Mon-Eco Industries, Inc.; 22-25.
  2. For indoor applications, adhesive shall have a VOC content of 80 g/L or less when calculated according to 40 CFR 59, Subpart D (EPA Method 24).
- D. ASJ Adhesive, and FSK Jacket Adhesive: Comply with MIL-A-3316C, Class 2, Grade A for bonding insulation jacket lap seams and joints.
  1. Products: Subject to compliance with requirements, provide one of the following:
    - a. Childers Brand, Specialty Construction Brands, Inc., a business of H. B. Fuller Company; CP-82.
    - b. Eagle Bridges - Marathon Industries; 225.
    - c. Foster Brand, Specialty Construction Brands, Inc., a business of H. B. Fuller Company; 85-20.
    - d. Mon-Eco Industries, Inc.; 22-25.
  2. For indoor applications, adhesive shall have a VOC content of 50 g/L or less when calculated according to 40 CFR 59, Subpart D (EPA Method 24).
- E. PVC Jacket Adhesive: Compatible with PVC jacket.
  1. Products: Subject to compliance with requirements, provide one of the following:
    - a. Dow Corning Corporation; 739, Dow Silicone.
    - b. Johns Manville; Zeston Perma-Weld, CEEL-TITE Solvent Welding Adhesive.
    - c. P.I.C. Plastics, Inc.; Welding Adhesive.
    - d. Speedline Corporation; Polyco VP Adhesive.
  2. For indoor applications, adhesive shall have a VOC content of 50 g/L or less when calculated according to 40 CFR 59, Subpart D (EPA Method 24).

## 2.4 MASTICS

- A. Materials shall be compatible with insulation materials, jackets, and substrates; comply with MIL-PRF-19565C, Type II.
  1. For indoor applications, use mastics that have a VOC content of 50 g/L or less when calculated according to 40 CFR 59, Subpart D (EPA Method 24).
- B. Vapor-Barrier Mastic: Water based; suitable for indoor use on below-ambient services.
  1. Products: Subject to compliance with requirements, provide one of the following:
    - a. Foster Brand, Specialty Construction Brands, Inc., a business of H. B. Fuller Company; 30-80/30-90.
    - b. Vimasco Corporation; 749.
  2. Water-Vapor Permeance: ASTM E 96/E 96M, Procedure B, 0.013 perm at 43-mil dry film thickness.

3. Service Temperature Range: Minus 20 to plus 180 deg F .
  4. Solids Content: ASTM D 1644, 58 percent by volume and 70 percent by weight.
  5. Color: White.
- C. Vapor-Barrier Mastic: Solvent based; suitable for indoor use on below-ambient services.
1. Products: Subject to compliance with requirements, provide one of the following:
    - a. Childers Brand, Specialty Construction Brands, Inc., a business of H. B. Fuller Company; CP-30.
    - b. Eagle Bridges - Marathon Industries; 501.
    - c. Foster Brand, Specialty Construction Brands, Inc., a business of H. B. Fuller Company; 30-35.
    - d. Mon-Eco Industries, Inc.; 55-10.
  2. Water-Vapor Permeance: ASTM F 1249, 0.05 perm at 35-mil dry film thickness.
  3. Service Temperature Range: 0 to 180 deg F .
  4. Solids Content: ASTM D 1644, 44 percent by volume and 62 percent by weight.
  5. Color: White.
- D. Vapor-Barrier Mastic: Solvent based; suitable for outdoor use on below-ambient services.
1. Products: Subject to compliance with requirements, provide one of the following:
    - a. Childers Brand, Specialty Construction Brands, Inc., a business of H. B. Fuller Company; Encacel.
    - b. Eagle Bridges - Marathon Industries; 570.
    - c. Foster Brand, Specialty Construction Brands, Inc., a business of H. B. Fuller Company; 60-95/60-96.
  2. Water-Vapor Permeance: ASTM F 1249, 0.05 perm at 30-mil dry film thickness.
  3. Service Temperature Range: Minus 50 to plus 220 deg F .
  4. Solids Content: ASTM D 1644, 33 percent by volume and 46 percent by weight.
  5. Color: White.
- E. Breather Mastic: Water based; suitable for indoor and outdoor use on above-ambient services.
1. Products: Subject to compliance with requirements, provide one of the following:
    - a. Childers Brand, Specialty Construction Brands, Inc., a business of H. B. Fuller Company; CP-10.
    - b. Eagle Bridges - Marathon Industries; 550.
    - c. Foster Brand, Specialty Construction Brands, Inc., a business of H. B. Fuller Company; 46-50.
    - d. Mon-Eco Industries, Inc.; 55-50.
    - e. Vimasco Corporation; WC-1/WC-5.
  2. Water-Vapor Permeance: ASTM F 1249, 1.8 perms at 0.0625-inch dry film thickness.
  3. Service Temperature Range: Minus 20 to plus 180 deg F .
  4. Solids Content: 60 percent by volume and 66 percent by weight.

5. Color: White.

## 2.5 SEALANTS

### A. ASJ Flashing Sealants, and PVC Jacket Flashing Sealants:

1. Products: Subject to compliance with requirements, provide the following:
  - a. Childers Brand, Specialty Construction Brands, Inc., a business of H. B. Fuller Company; CP-76.
2. Materials shall be compatible with insulation materials, jackets, and substrates.
3. Fire- and water-resistant, flexible, elastomeric sealant.
4. Service Temperature Range: Minus 40 to plus 250 deg F .
5. Color: White.
6. For indoor applications, sealants shall have a VOC content of 420 g/L or less when calculated according to 40 CFR 59, Subpart D (EPA Method 24).

## 2.6 FACTORY-APPLIED JACKETS

- ### A. Insulation system schedules indicate factory-applied jackets on various applications. When factory-applied jackets are indicated, comply with the following:
1. ASJ-SSL: ASJ with self-sealing, pressure-sensitive, acrylic-based adhesive covered by a removable protective strip; complying with ASTM C 1136, Type I.

## 2.7 FIELD-APPLIED JACKETS

- ### A. Field-applied jackets shall comply with ASTM C 921, Type I, unless otherwise indicated.
- ### B. PVC Jacket: High-impact-resistant, UV-resistant PVC complying with ASTM D 1784, Class 16354-C; thickness as scheduled; roll stock ready for shop or field cutting and forming. Thickness is indicated in field-applied jacket schedules.
1. Products: Subject to compliance with requirements, provide one of the following:
    - a. Johns Manville; Zeston.
    - b. P.I.C. Plastics, Inc.; FG Series.
    - c. Proto Corporation; LoSmoke.
    - d. Speedline Corporation; SmokeSafe.
  2. Adhesive: As recommended by jacket material manufacturer.
  3. Color: Color-code jackets based on system.
    - a. White.
  4. Factory-fabricated fitting covers to match jacket if available; otherwise, field fabricate.
    - a. Shapes: 45- and 90-degree, short- and long-radius elbows, tees, valves, flanges, unions, reducers, end caps, soil-pipe hubs, traps, mechanical joints, and P-trap and supply covers for lavatories.

## C. Metal Jacket:

1. Products: Subject to compliance with requirements, provide one of the following:
  - a. Childers Brand, Specialty Construction Brands, Inc., a business of H. B. Fuller Company; Metal Jacketing Systems.
  - b. ITW Insulation Systems; Aluminum and Stainless Steel Jacketing.
  - c. RPR Products, Inc.; Insul-Mate.
2. Aluminum Jacket: Comply with ASTM B 209 (ASTM B 209M), Alloy 3003, 3005, 3105, or 5005, Temper H-14.
  - a. Sheet and roll stock ready for shop or field sizing or factory cut and rolled to size.
  - b. Finish and thickness are indicated in field-applied jacket schedules.
  - c. Moisture Barrier for Indoor Applications: 1-mil- thick, heat-bonded polyethylene and kraft paper. [3-mil- thick, heat-bonded polyethylene and kraft paper] [2.5-mil- thick polysurlyn].
  - d. Moisture Barrier for Outdoor Applications: 3-mil- thick, heat-bonded polyethylene and kraft paper. [2.5-mil- thick polysurlyn].
  - e. Factory-Fabricated Fitting Covers:
    - 1) Same material, finish, and thickness as jacket.
    - 2) Preformed 2-piece or gore, 45- and 90-degree, short- and long-radius elbows.
    - 3) Tee covers.
    - 4) Flange and union covers.
    - 5) End caps.
    - 6) Beveled collars.
    - 7) Valve covers.
    - 8) Field fabricate fitting covers only if factory-fabricated fitting covers are not available.

## 2.8 TAPES

- A. ASJ Tape: White vapor-retarder tape matching factory-applied jacket with acrylic adhesive, complying with ASTM C 1136.
  1. Products: Subject to compliance with requirements, provide one of the following:
    - a. ABI, Ideal Tape Division; 428 AWF ASJ.
    - b. Avery Dennison Corporation, Specialty Tapes Division; Fasson 0836.
    - c. Compac Corporation; 104 and 105.
    - d. Venture Tape; 1540 CW Plus, 1542 CW Plus, and 1542 CW Plus/SQ.
  2. Width: 3 inches.
  3. Thickness: 11.5 mils.
  4. Adhesion: 90 ounces force/inch in width.
  5. Elongation: 2 percent.
  6. Tensile Strength: 40 lbf/inch in width.
  7. ASJ Tape Disks and Squares: Precut disks or squares of ASJ tape.

- B. PVC Tape: White vapor-retarder tape matching field-applied PVC jacket with acrylic adhesive; suitable for indoor and outdoor applications.
1. Products: Subject to compliance with requirements, provide one of the following:
    - a. ABI, Ideal Tape Division; 370 White PVC tape.
    - b. Compac Corporation; 130.
    - c. Venture Tape; 1506 CW NS.
  2. Width: 2 inches.
  3. Thickness: 6 mils.
  4. Adhesion: 64 ounces force/inch in width.
  5. Elongation: 500 percent.
  6. Tensile Strength: 18 lbf/inch in width.
- C. Aluminum-Foil Tape: Vapor-retarder tape with acrylic adhesive.
1. Products: Subject to compliance with requirements, provide one of the following:
    - a. ABI, Ideal Tape Division; 488 AWF.
    - b. Avery Dennison Corporation, Specialty Tapes Division; Fasson 0800.
    - c. Compac Corporation; 120.
    - d. Venture Tape; 3520 CW.
  2. Width: 2 inches.
  3. Thickness: 3.7 mils.
  4. Adhesion: 100 ounces force/inch in width.
  5. Elongation: 5 percent.
  6. Tensile Strength: 34 lbf/inch in width.

## 2.9 SECUREMENTS

- A. Staples: Outward-clinching insulation staples, nominal 3/4-inch- wide, stainless steel or Monel.

## 2.10 PROTECTIVE SHIELDING GUARDS

- A. Protective Shielding Pipe Covers:
1. Manufacturers: Subject to compliance with requirements provide products by one of the following:
    - a. Engineered Brass Company.
    - b. Insul-Tect Products Co.; a subsidiary of MVG Molded Products.
    - c. McGuire Manufacturing.
    - d. Plumberex.
    - e. Truebro; a brand of IPS Corporation.
    - f. Zurn Industries, LLC; Tubular Brass Plumbing Products Operation.



2. Description: Manufactured plastic wraps for covering plumbing fixture hot- and cold-water supplies and trap and drain piping. Comply with Americans with Disabilities Act (ADA) requirements.
- B. Protective Shielding Piping Enclosures:
1. Manufacturers: Subject to compliance with requirements provide products by one of the following:
    - a. Truebro; a brand of IPS Corporation.
    - b. Zurn Industries, LLC; Tubular Brass Plumbing Products Operation.
  2. Description: Manufactured plastic enclosure for covering plumbing fixture hot- and cold-water supplies and trap and drain piping. Comply with ADA requirements.

### PART 3 - EXECUTION

#### 3.1 EXAMINATION

- A. Examine substrates and conditions for compliance with requirements for installation tolerances and other conditions affecting performance of insulation application.
  1. Verify that systems to be insulated have been tested and are free of defects.
  2. Verify that surfaces to be insulated are clean and dry.
- B. Proceed with installation only after unsatisfactory conditions have been corrected.

#### 3.2 PREPARATION

- A. Surface Preparation: Clean and dry surfaces to receive insulation. Remove materials that will adversely affect insulation application.
- B. Coordinate insulation installation with the trade installing heat tracing. Comply with requirements for heat tracing that apply to insulation.
- C. Mix insulating cements with clean potable water; if insulating cements are to be in contact with stainless-steel surfaces, use demineralized water.

#### 3.3 GENERAL INSTALLATION REQUIREMENTS

- A. Install insulation materials, accessories, and finishes with smooth, straight, and even surfaces; free of voids throughout the length of piping including fittings, valves, and specialties.
- B. Install insulation materials, forms, vapor barriers or retarders, jackets, and thicknesses required for each item of pipe system as specified in insulation system schedules.

- C. Install accessories compatible with insulation materials and suitable for the service. Install accessories that do not corrode, soften, or otherwise attack insulation or jacket in either wet or dry state.
- D. Install insulation with longitudinal seams at top and bottom of horizontal runs.
- E. Install multiple layers of insulation with longitudinal and end seams staggered.
- F. Do not weld brackets, clips, or other attachment devices to piping, fittings, and specialties.
- G. Keep insulation materials dry during application and finishing.
- H. Install insulation with tight longitudinal seams and end joints. Bond seams and joints with adhesive recommended by insulation material manufacturer.
- I. Install insulation with least number of joints practical.
- J. Where vapor barrier is indicated, seal joints, seams, and penetrations in insulation at hangers, supports, anchors, and other projections with vapor-barrier mastic.
  - 1. Install insulation continuously through hangers and around anchor attachments.
  - 2. For insulation application where vapor barriers are indicated, extend insulation on anchor legs from point of attachment to supported item to point of attachment to structure. Taper and seal ends at attachment to structure with vapor-barrier mastic.
  - 3. Install insert materials and install insulation to tightly join the insert. Seal insulation to insulation inserts with adhesive or sealing compound recommended by insulation material manufacturer.
  - 4. Cover inserts with jacket material matching adjacent pipe insulation. Install shields over jacket, arranged to protect jacket from tear or puncture by hanger, support, and shield.
- K. Apply adhesives, mastics, and sealants at manufacturer's recommended coverage rate and wet and dry film thicknesses.
- L. Install insulation with factory-applied jackets as follows:
  - 1. Draw jacket tight and smooth.
  - 2. Cover circumferential joints with 3-inch wide strips, of same material as insulation jacket. Secure strips with adhesive and outward clinching staples along both edges of strip, spaced 4 inches o.c.
  - 3. Overlap jacket longitudinal seams at least 1-1/2 inches. Install insulation with longitudinal seams at bottom of pipe. Clean and dry surface to receive self-sealing lap. Staple laps with outward clinching staples along edge at:
    - a. 2 inches o.c.
    - b. For below-ambient services, apply vapor-barrier mastic over staples.
  - 4. Cover joints and seams with tape, according to insulation material manufacturer's written instructions, to maintain vapor seal.
  - 5. Where vapor barriers are indicated, apply vapor-barrier mastic on seams and joints and at ends adjacent to pipe flanges and fittings.

- M. Cut insulation in a manner to avoid compressing insulation more than 75 percent of its nominal thickness.
- N. Finish installation with systems at operating conditions. Repair joint separations and cracking due to thermal movement.
- O. Repair damaged insulation facings by applying same facing material over damaged areas. Extend patches at least 4 inches beyond damaged areas. Adhere, staple, and seal patches similar to butt joints.
- P. For above-ambient services, do not install insulation to the following:
  - 1. Vibration-control devices.
  - 2. Testing agency labels and stamps.
  - 3. Nameplates and data plates.
  - 4. Cleanouts.

### 3.4 PENETRATIONS

- A. Insulation Installation at Roof Penetrations: Install insulation continuously through roof penetrations.
  - 1. Seal penetrations with flashing sealant.
  - 2. For applications requiring only indoor insulation, terminate insulation above roof surface and seal with joint sealant. For applications requiring indoor and outdoor insulation, install insulation for outdoor applications tightly joined to indoor insulation ends. Seal joint with joint sealant.
  - 3. Extend jacket of outdoor insulation outside roof flashing at least 2 inches below top of roof flashing.
  - 4. Seal jacket to roof flashing with flashing sealant.
- B. Insulation Installation at Underground Exterior Wall Penetrations: Terminate insulation flush with sleeve seal. Seal terminations with flashing sealant.
- C. Insulation Installation at Aboveground Exterior Wall Penetrations: Install insulation continuously through wall penetrations.
  - 1. Seal penetrations with flashing sealant.
  - 2. For applications requiring only indoor insulation, terminate insulation inside wall surface and seal with joint sealant. For applications requiring indoor and outdoor insulation, install insulation for outdoor applications tightly joined to indoor insulation ends. Seal joint with joint sealant.
  - 3. Extend jacket of outdoor insulation outside wall flashing and overlap wall flashing at least 2 inches.
  - 4. Seal jacket to wall flashing with flashing sealant.
- D. Insulation Installation at Interior Wall and Partition Penetrations (That Are Not Fire Rated): Install insulation continuously through walls and partitions.
- E. Insulation Installation at Fire-Rated Wall and Partition Penetrations: Install insulation continuously through penetrations of fire-rated walls and partitions.

1. Comply with requirements in Section 078413 "Penetration Firestopping" for firestopping and fire-resistive joint sealers.

F. Insulation Installation at Floor Penetrations:

1. Pipe: Install insulation continuously through floor penetrations.
2. Seal penetrations through fire-rated assemblies. Comply with requirements in Section 078413 "Penetration Firestopping."

### 3.5 GENERAL PIPE INSULATION INSTALLATION

- A. Requirements in this article generally apply to all insulation materials except where more specific requirements are specified in various pipe insulation material installation articles.

B. Insulation Installation on Fittings, Valves, Strainers, Flanges, and Unions:

1. Install insulation over fittings, valves, strainers, flanges, unions, and other specialties with continuous thermal and vapor-retarder integrity unless otherwise indicated.
2. Insulate pipe elbows using preformed fitting insulation or mitered fittings made from same material and density as adjacent pipe insulation. Each piece shall be butted tightly against adjoining piece and bonded with adhesive. Fill joints, seams, voids, and irregular surfaces with insulating cement finished to a smooth, hard, and uniform contour that is uniform with adjoining pipe insulation.
3. Insulate tee fittings with preformed fitting insulation or sectional pipe insulation of same material and thickness as used for adjacent pipe. Cut sectional pipe insulation to fit. Butt each section closely to the next and hold in place with tie wire. Bond pieces with adhesive.
4. Insulate valves using preformed fitting insulation or sectional pipe insulation of same material, density, and thickness as used for adjacent pipe. Overlap adjoining pipe insulation by not less than two times the thickness of pipe insulation, or one pipe diameter, whichever is thicker. For valves, insulate up to and including the bonnets, valve stuffing-box studs, bolts, and nuts. Fill joints, seams, and irregular surfaces with insulating cement.
5. Insulate strainers using preformed fitting insulation or sectional pipe insulation of same material, density, and thickness as used for adjacent pipe. Overlap adjoining pipe insulation by not less than two times the thickness of pipe insulation, or one pipe diameter, whichever is thicker. Fill joints, seams, and irregular surfaces with insulating cement. Insulate strainers so strainer basket flange or plug can be easily removed and replaced without damaging the insulation and jacket. Provide a removable reusable insulation cover. For below-ambient services, provide a design that maintains vapor barrier.
6. Insulate flanges and unions using a section of oversized preformed pipe insulation. Overlap adjoining pipe insulation by not less than two times the thickness of pipe insulation, or one pipe diameter, whichever is thicker.
7. Cover segmented insulated surfaces with a layer of finishing cement and coat with a mastic. Install vapor-barrier mastic for below-ambient services and a breather mastic for above-ambient services. Reinforce the mastic with fabric-reinforcing mesh. Trowel the mastic to a smooth and well-shaped contour.
8. For services not specified to receive a field-applied jacket except for flexible elastomeric, install fitted PVC cover over elbows, tees, strainers, valves, flanges,

- and unions. Terminate ends with PVC end caps. Tape PVC covers to adjoining insulation facing using PVC tape.
9. Stencil or label the outside insulation jacket of each union with the word "union." Match size and color of pipe labels.
- C. Insulate instrument connections for thermometers, pressure gages, pressure temperature taps, test connections, flow meters, sensors, switches, and transmitters on insulated pipes. Shape insulation at these connections by tapering it to and around the connection with insulating cement and finish with finishing cement, mastic, and flashing sealant.
- D. Install removable insulation covers at locations indicated. Installation shall conform to the following:
1. Make removable flange and union insulation from sectional pipe insulation of same thickness as that on adjoining pipe. Install same insulation jacket as adjoining pipe insulation.
  2. When flange and union covers are made from sectional pipe insulation, extend insulation from flanges or union long at least two times the insulation thickness over adjacent pipe insulation on each side of flange or union. Secure flange cover in place with stainless-steel or aluminum bands. Select band material compatible with insulation and jacket.
  3. Construct removable valve insulation covers in same manner as for flanges, except divide the two-part section on the vertical center line of valve body.
  4. When covers are made from block insulation, make two halves, each consisting of mitered blocks wired to stainless-steel fabric. Secure this wire frame, with its attached insulation, to flanges with tie wire. Extend insulation at least 2 inches over adjacent pipe insulation on each side of valve. Fill space between flange or union cover and pipe insulation with insulating cement. Finish cover assembly with insulating cement applied in two coats. After first coat is dry, apply and trowel second coat to a smooth finish.
  5. Unless a PVC jacket is indicated in field-applied jacket schedules, finish exposed surfaces with a metal jacket.

### 3.6 INSTALLATION OF FLEXIBLE ELASTOMERIC INSULATION

- A. Seal longitudinal seams and end joints with manufacturer's recommended adhesive to eliminate openings in insulation that allow passage of air to surface being insulated.
- B. Insulation Installation on Pipe Flanges:
1. Install pipe insulation to outer diameter of pipe flange.
  2. Make width of insulation section same as overall width of flange and bolts, plus twice the thickness of pipe insulation.
  3. Fill voids between inner circumference of flange insulation and outer circumference of adjacent straight pipe segments with cut sections of sheet insulation of same thickness as pipe insulation.
  4. Secure insulation to flanges and seal seams with manufacturer's recommended adhesive to eliminate openings in insulation that allow passage of air to surface being insulated.
- C. Insulation Installation on Pipe Fittings and Elbows:

1. Install mitered sections of pipe insulation.
2. Secure insulation materials and seal seams with manufacturer's recommended adhesive to eliminate openings in insulation that allow passage of air to surface being insulated.

D. Insulation Installation on Valves and Pipe Specialties:

1. Install preformed valve covers manufactured of same material as pipe insulation when available.
2. When preformed valve covers are not available, install cut sections of pipe and sheet insulation to valve body. Arrange insulation to permit access to packing and to allow valve operation without disturbing insulation.
3. Install insulation to flanges as specified for flange insulation application.
4. Secure insulation to valves and specialties and seal seams with manufacturer's recommended adhesive to eliminate openings in insulation that allow passage of air to surface being insulated.

### 3.7 INSTALLATION OF MINERAL-FIBER INSULATION

A. Insulation Installation on Straight Pipes and Tubes:

1. Secure each layer of preformed pipe insulation to pipe with wire or bands and tighten bands without deforming insulation materials.
2. Where vapor barriers are indicated, seal longitudinal seams, end joints, and protrusions with vapor-barrier mastic and joint sealant.
3. For insulation with factory-applied jackets on above-ambient surfaces, secure laps with outward clinched staples at 6 inches o.c.
4. For insulation with factory-applied jackets on below-ambient surfaces, do not staple longitudinal tabs. Instead, secure tabs with additional adhesive as recommended by insulation material manufacturer and seal with vapor-barrier mastic and flashing sealant.

B. Insulation Installation on Pipe Flanges:

1. Install preformed pipe insulation to outer diameter of pipe flange.
2. Make width of insulation section same as overall width of flange and bolts, plus twice the thickness of pipe insulation.
3. Fill voids between inner circumference of flange insulation and outer circumference of adjacent straight pipe segments with mineral-fiber blanket insulation.
4. Install jacket material with manufacturer's recommended adhesive, overlap seams at least 1 inch, and seal joints with flashing sealant.

C. Insulation Installation on Pipe Fittings and Elbows:

1. Install preformed sections of same material as straight segments of pipe insulation when available.
2. When preformed insulation elbows and fittings are not available, install mitered sections of pipe insulation, to a thickness equal to adjoining pipe insulation. Secure insulation materials with wire or bands.

D. Insulation Installation on Valves and Pipe Specialties:

1. Install preformed sections of same material as straight segments of pipe insulation when available.
2. When preformed sections are not available, install mitered sections of pipe insulation to valve body.
3. Arrange insulation to permit access to packing and to allow valve operation without disturbing insulation.
4. Install insulation to flanges as specified for flange insulation application.

### 3.8 FIELD-APPLIED JACKET INSTALLATION

- A. Where PVC jackets are indicated, install with 1-inch overlap at longitudinal seams and end joints. Seal with manufacturer's recommended adhesive.
  1. Apply two continuous beads of adhesive to seams and joints, one bead under lap and the finish bead along seam and joint edge.
- B. Where metal jackets are indicated, install with 2-inch overlap at longitudinal seams and end joints. Overlap longitudinal seams arranged to shed water. Seal end joints with weatherproof sealant recommended by insulation manufacturer. Secure jacket with stainless-steel bands 12 inches o.c. and at end joints.

### 3.9 PIPING INSULATION SCHEDULE, GENERAL

- A. Acceptable preformed pipe and tubular insulation materials and thicknesses are identified for each piping system and pipe size range. If more than one material is listed for a piping system, selection from materials listed is Contractor's option.
- B. Insulation shall have a k value that meets the minimum requirements of the latest International Energy Conservation Code (IECC).
- C. Items Not Insulated: Unless otherwise indicated, do not install insulation on the following:
  1. Drainage piping located in crawl spaces.
  2. Underground piping.
  3. Chrome-plated pipes and fittings unless there is a potential for personnel injury.

### 3.10 INDOOR PIPING INSULATION SCHEDULE

- A. Domestic Cold Water:
  1. NPS 1-1/2 and Smaller: Insulation shall be one of the following;
    - a. Flexible Elastomeric:
      - 1) 1 inch thick
    - b. Mineral-Fiber, Preformed Pipe Insulation, Type I:
      - 1) 1 inch thick
  2. NPS 2 and Larger: Insulation shall be one of the following:

- a. Flexible Elastomeric:
    - 1) 1-1/2 inches thick.
  - b. Mineral-Fiber, Preformed Pipe Insulation:
    - 1) 1-1/2 inches thick.
- B. Domestic Hot and Recirculated Hot Water:
- 1. NPS 1-1/2 and Smaller: Insulation shall be the following:
    - a. Mineral-Fiber, Preformed Pipe Insulation, Type I:
      - 1) 1 inch thick.
  - 2. NPS 2 and Larger: Insulation shall be the following:
    - a. Mineral-Fiber, Preformed Pipe Insulation, Type I:
      - 1) 1-1/2 inches thick
- C. Domestic Chilled Water (Potable):
- 1. All Pipe Sizes: Insulation shall be one of the following:
    - a. Flexible Elastomeric: 1 inch thick.
    - b. Mineral-Fiber, Preformed Pipe Insulation, Type I: 1 inch thick.
- D. Floor Drains, Traps, and Sanitary Drain Piping within 10 Feet of Drain Receiving Condensate and Equipment Drain Water below 60 Deg F :
- 1. All Pipe Sizes: Insulation shall be one of the following:
    - a. Flexible Elastomeric:
      - 1) 3/4 inch thick.
    - b. Mineral-Fiber, Preformed Pipe Insulation, Type I:
      - 1) 3/4 inch thick.
- E. Hot Service Drains:
- 1. All Pipe Sizes: Insulation shall be the following:
    - a. Mineral-Fiber, Preformed Pipe, Type I or II: 1 inch thick.
- F. Hot Service Vents:
- 1. All Pipe Sizes: Insulation shall be the following:
    - a. Mineral-Fiber, Preformed Pipe, Type I or II: 1 inch thick.
- 3.11 INDOOR, FIELD-APPLIED JACKET SCHEDULE
- A. Install jacket over insulation material. For insulation with factory-applied jacket, install the field-applied jacket over the factory-applied jacket.



- B. If more than one material is listed, selection from materials listed is Contractor's option.
- C. Piping, Concealed:
  - 1. None.
- D. Piping, Exposed:
  - 1. PVC:
    - a. White: 30 mils thick

END OF SECTION

**SECTION 22 11 16 - DOMESTIC WATER PIPING**

## PART 1 - GENERAL

## 1.1 RELATED DOCUMENTS

- A. Drawings and general provisions of the Contract, including General and Supplementary Conditions and Division 01 Specification Sections, apply to this Section.

## 1.2 SUMMARY

- A. Section Includes:

1. Under-building-slab and aboveground domestic water pipes, tubes, and fittings inside buildings.
2. Encasement for piping.

## 1.3 SEISMIC REQUIREMENTS

- A. Seismic Performance: Pipe hangers and supports shall withstand the effects of earthquake motions determined according to SEI/ASCE 7 and with the requirements specified in Section 230548 "Vibration and Seismic Controls for HVAC."

1. For piping with a seismic importance factor of 1.0 the term "withstand" means "the system will remain in place without separation of any parts when subjected to the seismic forces specified."
2. For piping with a seismic importance factor of 1.5 the term "withstand" means "the system will remain in place without separation of any parts when subjected to the seismic forces specified and the system will be fully operational after the seismic event."

## 1.4 ACTION SUBMITTALS

- A. Product Data: For transition fittings and dielectric fittings.

- B. Delegated-Design Submittal:

1. Design calculations and detailed fabrication and assembly of pipe anchors and alignment guides, hangers and supports for multiple pipes, expansion joints and loops, and attachments of the same to the building structure.
2. Locations of pipe anchors and alignment guides and expansion joints and loops.
3. Locations of and details for penetrations, including sleeves and sleeve seals for exterior walls, floors, basement, and foundation walls.

## 1.5 INFORMATIONAL SUBMITTALS

- A. System purging and disinfecting activities report.
- B. Field quality-control reports.

## 1.6 FIELD CONDITIONS

- A. Interruption of Existing Water Service: Do not interrupt water service to facilities occupied by Owner or others unless permitted under the following conditions and then only after arranging to provide temporary water service according to requirements indicated:
  - 1. Notify Construction Manager or owner no fewer than two days in advance of proposed interruption of water service.

## PART 2 - PRODUCTS

## 2.1 PIPING MATERIALS

- A. Comply with requirements in "Piping Schedule" Article for applications of pipe, tube, fitting materials, and joining methods for specific services, service locations, and pipe sizes.
- B. Potable-water piping and components shall comply with NSF 14 and NSF 61. Plastic piping components shall be marked with "NSF-pw."
- C. All piping shall be American made and tested; no import pipe will be permitted.
- D. All exposed water supply piping in toilet rooms, custodial rooms and kitchens shall be chromium plated.
- E. All piping installed in or passing through a plenum must be plenum rated, fire wrapped, or installed in a metal conduit.

## 2.2 COPPER TUBE AND FITTINGS

- A. Hard Copper Tube: ASTM B 88, Type K and ASTM B 88, Type L water tube, drawn temper.
- B. Soft Copper Tube: ASTM B 88, Type K and ASTM B 88, Type L water tube, annealed temper.
- C. Cast-Copper, Solder-Joint Fittings: ASME B16.18, pressure fittings.
- D. Wrought-Copper, Solder-Joint Fittings: ASME B16.22, wrought-copper pressure fittings.
- E. Bronze Flanges: ASME B16.24, Class 150, with solder-joint ends.

- F. Copper Unions:
  - 1. MSS SP-123.
  - 2. Cast-copper-alloy, hexagonal-stock body.
  - 3. Ball-and-socket, metal-to-metal seating surfaces.
  - 4. Solder-joint or threaded ends.

## 2.3 DUCTILE-IRON PIPE AND FITTINGS

- A. Mechanical-Joint, Ductile-Iron Pipe:
  - 1. AWWA C151/A21.51, with mechanical-joint bell and plain spigot end unless grooved or flanged ends are indicated.
  - 2. Glands, Gaskets, and Bolts: AWWA C111/A21.11, ductile- or gray-iron glands, rubber gaskets, and steel bolts.
- B. Standard-Pattern, Mechanical-Joint Fittings:
  - 1. AWWA C110/A21.10, ductile or gray iron.
  - 2. Glands, Gaskets, and Bolts: AWWA C111/A21.11, ductile- or gray-iron glands, rubber gaskets, and steel bolts.
- C. Compact-Pattern, Mechanical-Joint Fittings:
  - 1. AWWA C153/A21.53, ductile iron.
  - 2. Glands, Gaskets, and Bolts: AWWA C111/A21.11, ductile- or gray-iron glands, rubber gaskets, and steel bolts.
- D. Plain-End, Ductile-Iron Pipe: AWWA C151/A21.51.

## 2.4 PIPING JOINING MATERIALS

- A. Pipe-Flange Gasket Materials:
  - 1. AWWA C110/A21.10, rubber, flat face, 1/8 inch thick or ASME B16.21, nonmetallic and asbestos free unless otherwise indicated.
  - 2. Full-face or ring type unless otherwise indicated.
- B. Metal, Pipe-Flange Bolts and Nuts: ASME B18.2.1, carbon steel unless otherwise indicated.
- C. Solder Filler Metals: ASTM B 32, lead-free alloys.
- D. Flux: ASTM B 813, water flushable.
- E. Brazing Filler Metals: AWS A5.8/A5.8M, BCuP Series, copper-phosphorus alloys for general-duty brazing unless otherwise indicated.

## 2.5 TRANSITION FITTINGS

- A. General Requirements:
  - 1. Same size as pipes to be joined.
  - 2. Pressure rating at least equal to pipes to be joined.
  - 3. End connections compatible with pipes to be joined.
- B. Fitting-Type Transition Couplings: Manufactured piping coupling or specified piping system fitting.
- C. Sleeve-Type Transition Coupling: AWWA C219.
  - 1. Manufacturers: Subject to compliance with requirements, provide products by one of the following:
    - a. Cascade Waterworks Manufacturing.
    - b. Dresser, Inc.; Piping Specialties Products.
    - c. Ford Meter Box Company, Inc. (The).
    - d. JCM Industries.
    - e. Romac Industries, Inc.
    - f. Smith-Blair, Inc.; a Sensus company.
    - g. Viking Johnson.
- D. Plastic-to-Metal Transition Fittings:
  - 1. Manufacturers: Subject to compliance with requirements, provide products by one of the following
    - a. Charlotte Pipe and Foundry Company.
    - b. Harvel Plastics, Inc.
    - c. Spears Manufacturing Company.
  - 2. Description:
    - a. CPVC or PVC one-piece fitting with manufacturer's Schedule 80 equivalent dimensions.
    - b. One end with threaded brass insert and one solvent-cement-socket or threaded end.
- E. PP-to-Metal Transition Fittings:
  - 1. Description:
    - a. PP one-piece fitting with manufacturer's Schedule 80 equivalent dimensions.
    - b. One end with threaded brass insert and one fusion-socket end.
- F. Plastic-to-Metal Transition Unions:
  - 1. Manufacturers: Subject to compliance with requirements, provide products by one of the following:
    - a. Colonial Engineering, Inc.
    - b. NIBCO Inc.
    - c. Spears Manufacturing Company.

2. Description:
  - a. CPVC four-part union.
  - b. Brass threaded end.
  - c. Solvent-cement-joint plastic end.
  - d. Rubber O-ring.
  - e. Union nut.

## 2.6 DIELECTRIC FITTINGS

- A. General Requirements: Assembly of copper alloy and ferrous materials with separating nonconductive insulating material. Include end connections compatible with pipes to be joined.
- B. Dielectric Nipples and Waterways:
  1. Manufacturers: Subject to compliance with requirements, provide products by one of the following:
    - a. Elster Perfection Corporation.
    - b. Grinnell Mechanical Products; Tyco Fire Products LP.
    - c. Matco-Norca.
    - d. Clearflow/Perfection Corp.
    - e. Precision Plumbing Products, Inc.
    - f. Victaulic Company.
  2. Standard: IAPMO PS 66 or ASTM F-1545-97.
  3. Electroplated steel nipple or waterway complying with ASTM F 1545 or ANSI/NSF-61 Compliant.
  4. Pressure Rating and Temperature: 300 psig at 225 deg F.
  5. End Connections: Male threaded or grooved.
  6. Lining: Inert and noncorrosive, propylene or LTHS.

## PART 3 - EXECUTION

### 3.1 EARTHWORK

- A. Comply with requirements in Division 31 Section "Earth Moving" for excavating, trenching, and backfilling.

### 3.2 PIPING INSTALLATION

- A. Drawing plans, schematics, and diagrams indicate general location and arrangement of domestic water piping. Indicated locations and arrangements are used to size pipe and calculate friction loss, expansion, and other design considerations. Install piping as indicated unless deviations to layout are approved on coordination drawings.
- B. Polypropylene pipe in or passing through plenums must be fire wrapped or installed in a metal conduit.

- C. Install copper tubing under building slab according to CDA's "Copper Tube Handbook."
- D. Install ductile-iron piping under building slab with restrained joints according to AWWA C600 and AWWA M41.
- E. Install shutoff valve, hose-end drain valve, strainer, pressure gage, and test tee with valve inside the building at each domestic water-service entrance. Comply with requirements for pressure gages in Division 22 Section "Meters and Gages for Plumbing Piping" and with requirements for drain valves and strainers in Division 22 Section "Domestic Water Piping Specialties."
- F. Install shutoff valve immediately upstream of each dielectric fitting.
- G. Install water-pressure-reducing valves downstream from shutoff valves. Comply with requirements for pressure-reducing valves in Division 22 Section "Domestic Water Piping Specialties."
- H. Install domestic water piping level with 0.25 percent slope downward toward drain and plumb.
  - 1. Piping will be drained seasonally for freeze protection.
- I. Rough-in domestic water piping for water-meter installation according to utility company's requirements.
- J. Install seismic restraints on piping. Comply with SEI/ASCE 7 and with requirements for seismic-restraint devices in Division 22 Section "Vibration and Seismic Controls for Plumbing Piping and Equipment."
- K. Install piping concealed from view and protected from physical contact by building occupants unless otherwise indicated and except in equipment rooms and service areas.
- L. Install piping indicated to be exposed and piping in equipment rooms and service areas at right angles or parallel to building walls. Diagonal runs are prohibited unless specifically indicated otherwise.
- M. Install piping above accessible ceilings to allow sufficient space for ceiling panel removal, and coordinate with other services occupying that space.
- N. Install piping to permit valve servicing.
- O. Install nipples, unions, special fittings, and valves with pressure ratings the same as or higher than the system pressure rating used in applications below unless otherwise indicated.
- P. Install piping free of sags and bends.
- Q. Install fittings for changes in direction and branch connections.
- R. Install unions in copper tubing at final connection to each piece of equipment, machine, and specialty.

- S. Install pressure gages on suction and discharge piping for each plumbing pump and packaged booster pump. Comply with requirements for pressure gages in Division 22 Section "Meters and Gages for Plumbing Piping."
- T. Install thermostats in hot-water circulation piping. Comply with requirements for thermostats in Division 22 Section "Domestic Water Pumps."
- U. Install thermometers on inlet piping from each water heater. Comply with requirements for thermometers in Division 22 Section "Meters and Gages for Plumbing Piping."
- V. Install sleeves for piping penetrations of walls, ceilings, and floors. Comply with requirements for sleeves specified in Division 22 Section "Sleeves and Sleeve Seals for Plumbing Piping."
- W. Install sleeve seals for piping penetrations of concrete walls and slabs. Comply with requirements for sleeve seals specified in Division 22 Section "Sleeves and Sleeve Seals for Plumbing Piping."
- X. Install escutcheons for piping penetrations of walls, ceilings, and floors. Comply with requirements for escutcheons specified in Division 22 Section "Escutcheons for Plumbing Piping."

### 3.3 JOINT CONSTRUCTION

- A. Ream ends of pipes and tubes and remove burrs. Bevel plain ends of steel pipe.
- B. Remove scale, slag, dirt, and debris from inside and outside of pipes, tubes, and fittings before assembly.
- C. Threaded Joints: Thread pipe with tapered pipe threads according to ASME B1.20.1. Cut threads full and clean using sharp dies. Ream threaded pipe ends to remove burrs and restore full ID. Join pipe fittings and valves as follows:
  - 1. Apply appropriate tape or thread compound to external pipe threads.
  - 2. Damaged Threads: Do not use pipe or pipe fittings with threads that are corroded or damaged.
- D. Brazed Joints for Copper Tubing: Comply with CDA's "Copper Tube Handbook," "Braze Joints" chapter.
- E. Soldered Joints for Copper Tubing: Apply ASTM B 813, water-flushable flux to end of tube. Join copper tube and fittings according to ASTM B 828 or CDA's "Copper Tube Handbook."
- F. Joint Construction for Grooved-End Copper Tubing: Make joints according to AWWA C606. Roll groove ends of tubes. Lubricate and install gasket over ends of tubes or tube and fitting. Install coupling housing sections over gasket with keys seated in tubing grooves. Install and tighten housing bolts.
- G. Joint Construction for Grooved-End, Ductile-Iron Piping: Make joints according to AWWA C606. Cut round-bottom grooves in ends of pipe at gasket-seat dimension required for specified (flexible or rigid) joint. Lubricate and install gasket over ends of



pipes or pipe and fitting. Install coupling housing sections over gasket with keys seated in piping grooves. Install and tighten housing bolts.

- H. Joint Construction for Grooved-End Steel Piping: Make joints according to AWWA C606. Roll groove ends of pipe as specified. Lubricate and install gasket over ends of pipes or pipe and fitting. Install coupling housing sections over gasket with keys seated in piping grooves. Install and tighten housing bolts.
- I. Flanged Joints: Select appropriate asbestos-free, nonmetallic gasket material in size, type, and thickness suitable for domestic water service. Join flanges with gasket and bolts according to ASME B31.9.
- J. Joints for Dissimilar-Material Piping: Make joints using adapters compatible with materials of both piping systems.

### 3.4 TRANSITION FITTING INSTALLATION

- A. Install transition couplings at joints of dissimilar piping.
- B. Transition Fittings in Underground Domestic Water Piping:
  - 1. Fittings for NPS 1-1/2 and Smaller: Fitting-type coupling.
  - 2. Fittings for NPS 2 and Larger: Sleeve-type coupling.
- C. Transition Fittings in Aboveground Domestic Water Piping NPS 2 and Smaller: Plastic-to-metal transition fittings.

### 3.5 DIELECTRIC FITTING INSTALLATION

- A. Install dielectric fittings in piping at connections of dissimilar metal piping and tubing.
- B. Dielectric Fittings for NPS 2 and Smaller: Use dielectric nipples/waterways.
- C. Dielectric Fittings for NPS 2-1/2 to NPS 4: Use dielectric nipples/waterways.
- D. Dielectric Fittings for NPS 5 and Larger: Use dielectric nipples/waterways.

### 3.6 HANGER AND SUPPORT INSTALLATION

- A. Comply with requirements for seismic-restraint devices in Division 22 Section "Vibration and Seismic Controls for Plumbing Piping and Equipment."
- B. Comply with requirements for pipe hanger, support products, and installation in Division 22 Section "Hangers and Supports for Plumbing Piping and Equipment."
  - 1. Vertical Piping: MSS Type 8 or 42, clamps.
  - 2. Individual, Straight, Horizontal Piping Runs:
    - a. 100 Feet and Less: MSS Type 1, adjustable, steel clevis hangers.
    - b. Longer Than 100 Feet: MSS Type 43, adjustable roller hangers.

- c. Longer Than 100 Feet if Indicated: MSS Type 49, spring cushion rolls.
    - 3. Multiple, Straight, Horizontal Piping Runs 100 Feet or Longer: MSS Type 44, pipe rolls. Support pipe rolls on trapeze.
    - 4. Base of Vertical Piping: MSS Type 52, spring hangers.
  - C. Support vertical piping and tubing at base and at each floor.
  - D. Rod diameter may be reduced one size for double-rod hangers, to a minimum of 3/8 inch.
  - E. Install hangers for copper tubing with the following maximum horizontal spacing and minimum rod diameters:
    - 1. NPS 3/4 and Smaller: 60 inches with 3/8-inch rod.
    - 2. NPS 1 and NPS 1-1/4: 72 inches with 3/8-inch rod.
    - 3. NPS 1-1/2 and NPS 2: 96 inches with 3/8-inch rod.
    - 4. NPS 2-1/2: 108 inches with 1/2-inch rod.
    - 5. NPS 3 to NPS 5: 10 feet with 1/2-inch rod.
    - 6. NPS 6: 10 feet with 5/8-inch rod.
    - 7. NPS 8: 10 feet with 3/4-inch rod.
  - F. Install supports for vertical copper tubing every 10 feet.
  - G. Install hangers for steel piping with the following maximum horizontal spacing and minimum rod diameters:
    - 1. NPS 1-1/4 and Smaller: 84 inches with 3/8-inch rod.
    - 2. NPS 1-1/2: 108 inches with 3/8-inch rod.
    - 3. NPS 2: 10 feet with 3/8-inch rod.
    - 4. NPS 2-1/2: 11 feet with 1/2-inch rod.
    - 5. NPS 3 and NPS 3-1/2: 12 feet with 1/2-inch rod.
    - 6. NPS 4 and NPS 5: 12 feet with 5/8-inch rod.
    - 7. NPS 6: 12 feet with 3/4-inch rod.
    - 8. NPS 8 to NPS 12: 12 feet with 7/8-inch rod.
  - H. Install supports for vertical steel piping every 15 feet.
  - I. Install supports for vertical PP piping every 60 inches for NPS 1 and smaller, and every 72 inches for NPS 1-1/4 and larger.
  - J. Support piping and tubing not listed in this article according to MSS SP-69 and manufacturer's written instructions.
- 3.7 CONNECTIONS
- A. Drawings indicate general arrangement of piping, fittings, and specialties.
  - B. When installing piping adjacent to equipment and machines, allow space for service and maintenance.

- C. Connect domestic water piping to exterior water-service piping. Use transition fitting to join dissimilar piping materials.
- D. Connect domestic water piping to water-service piping with shutoff valve; extend and connect to the following:
  - 1. Domestic Water Booster Pumps: Cold-water suction and discharge piping.
  - 2. Water Heaters: Cold-water inlet and hot-water outlet piping in sizes indicated, but not smaller than sizes of water heater connections.
  - 3. Plumbing Fixtures: Cold- and hot-water-supply piping in sizes indicated, but not smaller than that required by plumbing code. Comply with requirements for connection sizes in Division 22 plumbing fixture Sections.
  - 4. Equipment: Cold- and hot-water-supply piping as indicated, but not smaller than equipment connections. Provide shutoff valve and union for each connection. Use flanges instead of unions for NPS 2-1/2 and larger.

### 3.8 IDENTIFICATION

- A. Identify system components. Comply with requirements for identification materials and installation in Division 22 Section "Identification for Plumbing Piping and Equipment."
- B. Label pressure piping with system operating pressure.

### 3.9 FIELD QUALITY CONTROL

- A. Perform the following tests and inspections:
  - 1. Piping Inspections:
    - a. Do not enclose, cover, or put piping into operation until it has been inspected and approved by authorities having jurisdiction.
    - b. During installation, notify authorities having jurisdiction at least one day before inspection must be made. Perform tests specified below in presence of authorities having jurisdiction:
      - 1) Roughing-in Inspection: Arrange for inspection of piping before concealing or closing in after roughing in and before setting fixtures.
      - 2) Final Inspection: Arrange for authorities having jurisdiction to observe tests specified in "Piping Tests" Subparagraph below and to ensure compliance with requirements.
    - c. Reinspection: If authorities having jurisdiction find that piping will not pass tests or inspections, make required corrections and arrange for reinspection.
    - d. Reports: Prepare inspection reports and have them signed by authorities having jurisdiction.
  - 2. Piping Tests:
    - a. Fill domestic water piping. Check components to determine that they are not air bound and that piping is full of water.

- b. Test for leaks and defects in new piping and parts of existing piping that have been altered, extended, or repaired. If testing is performed in segments, submit a separate report for each test, complete with diagram of portion of piping tested.
  - c. Leave new, altered, extended, or replaced domestic water piping uncovered and unconcealed until it has been tested and approved. Expose work that was covered or concealed before it was tested.
  - d. Cap and subject piping to static water pressure of 50 psig above operating pressure, without exceeding pressure rating of piping system materials. Isolate test source and allow it to stand for four hours. Leaks and loss in test pressure constitute defects that must be repaired.
  - e. Repair leaks and defects with new materials, and retest piping or portion thereof until satisfactory results are obtained.
  - f. Prepare reports for tests and for corrective action required.
- B. Domestic water piping will be considered defective if it does not pass tests and inspections.
- C. Prepare test and inspection reports.

### 3.10 ADJUSTING

- A. Perform the following adjustments before operation:
1. Close drain valves, hydrants, and hose bibbs.
  2. Open shutoff valves to fully open position.
  3. Open throttling valves to proper setting.
  4. Adjust balancing valves in hot-water-circulation return piping to provide adequate flow.
    - a. Manually adjust ball-type balancing valves in hot-water-circulation return piping to provide hot-water flow in each branch.
    - b. Adjust calibrated balancing valves to flows indicated.
  5. Remove plugs used during testing of piping and for temporary sealing of piping during installation.
  6. Remove and clean strainer screens. Close drain valves and replace drain plugs.
  7. Remove filter cartridges from housings and verify that cartridges are as specified for application where used and are clean and ready for use.
  8. Check plumbing specialties and verify proper settings, adjustments, and operation.

### 3.11 CLEANING

- A. Clean and disinfect potable domestic water piping as follows:
1. Purge new piping and parts of existing piping that have been altered, extended, or repaired before using.
  2. Use purging and disinfecting procedures prescribed by authorities having jurisdiction; if methods are not prescribed, use procedures described in either AWWA C651 or AWWA C652 or follow procedures described below:

- a. Flush piping system with clean, potable water until dirty water does not appear at outlets.
  - b. Fill and isolate system according to either of the following:
    - 1) Fill system or part thereof with water/chlorine solution with at least 50 ppm of chlorine. Isolate with valves and allow to stand for 24 hours.
    - 2) Fill system or part thereof with water/chlorine solution with at least 200 ppm of chlorine. Isolate and allow to stand for three hours.
  - c. Flush system with clean, potable water until no chlorine is in water coming from system after the standing time.
  - d. Repeat procedures if biological examination shows contamination.
  - e. Submit water samples in sterile bottles to authorities having jurisdiction.
- B. Clean non-potable domestic water piping as follows:
1. Purge new piping and parts of existing piping that have been altered, extended, or repaired before using.
  2. Use purging procedures prescribed by authorities having jurisdiction or; if methods are not prescribed, follow procedures described below:
    - a. Flush piping system with clean, potable water until dirty water does not appear at outlets.
    - b. Submit water samples in sterile bottles to authorities having jurisdiction. Repeat procedures if biological examination shows contamination.
- C. Prepare and submit reports of purging and disinfecting activities. Include copies of water-sample approvals from authorities having jurisdiction.
- D. Clean interior of domestic water piping system. Remove dirt and debris as work progresses.

### 3.12 PIPING SCHEDULE

- A. Some piping types and sizes mentioned in this section may not be used on this project.
- B. Transition and special fittings with pressure ratings at least equal to piping rating may be used in applications below unless otherwise indicated.
- C. Flanges and unions may be used for aboveground piping joints unless otherwise indicated.
- D. All exposed water supply piping in toilet rooms, custodial rooms and kitchens shall be chromium plated.
- E. Aboveground domestic water piping, NPS 2 and smaller, shall be the following:
  1. Hard copper tube, ASTM B 88, Type L; cast- copper, solder-joint fittings; and soldered joints.
- F. Aboveground domestic water piping, NPS 2-1/2 to NPS 4, shall be the following:

1. Hard copper tube, ASTM B 88, Type L; cast- copper, solder-joint fittings; and soldered joints.

G. Aboveground domestic water piping, NPS 5 and larger , shall be the following:

1. Hard copper tube, ASTM B 88, Type L; cast- copper, solder-joint fittings; and soldered joints.

### 3.13 VALVE SCHEDULE

- A. Drawings indicate valve types to be used. Where specific valve types are not indicated, the following requirements apply:
1. Shutoff Duty: Use ball for piping NPS 3 and smaller. Use butterfly or ball, with flanged ends for piping NPS 4 and larger.
  2. Throttling Duty: Use ball or globe valves for piping NPS 2 and smaller. Use butterfly or ball valves with flanged ends for piping NPS 2-1/2 and larger.
  3. Hot-Water Circulation Piping, Balancing Duty: Calibrated balancing valves.
  4. Drain Duty: Hose-end drain valves.
- B. Use check valves to maintain correct direction of domestic water flow to and from equipment.

END OF SECTION

**SECTION 22 11 19 - DOMESTIC WATER PIPING SPECIALTIES**

## PART 1 - GENERAL

## 1.1 RELATED DOCUMENTS

- A. Drawings and general provisions of the Contract, including General and Supplementary Conditions and Division 01 Specification Sections, apply to this Section.

## 1.2 SUMMARY

- A. This Section includes the following domestic water piping specialties:

1. Vacuum breakers.
2. Backflow preventers.
3. Water pressure-reducing valves.
4. Balancing valves.
5. Temperature-actuated water mixing valves.
6. Strainers.
7. Outlet boxes.
8. Hose bibbs.
9. Wall hydrants.
10. Drain valves.
11. Water hammer arresters.
12. Trap-seal primer valves.
13. Trap-seal primer systems.

- B. Related Sections include the following:

1. Division 22 Section "Meters and Gages for Plumbing Piping" for thermometers, pressure gages, and flow meters in domestic water piping.
2. Division 22 Section "Emergency Plumbing Fixtures" for water tempering equipment.
3. Division 22 Section "Drinking Fountains and Water Coolers" for water filters for water coolers.

## 1.3 PERFORMANCE REQUIREMENTS

- A. Minimum Working Pressure for Domestic Water Piping Specialties: 125 psig, unless otherwise indicated.

## 1.4 SUBMITTALS

- A. Product Data: For each type of product indicated.
- B. Shop Drawings: Diagram power, signal, and control wiring.
- C. Field quality-control test reports.

- D. Operation and Maintenance Data: For domestic water piping specialties to include in emergency, operation, and maintenance manuals.

## 1.5 QUALITY ASSURANCE

- A. Electrical Components, Devices, and Accessories: Listed and labeled as defined in NFPA 70, Article 100, by a testing agency acceptable to authorities having jurisdiction, and marked for intended use.
- B. NSF Compliance:
  - 1. Comply with NSF 14, "Plastics Piping Components and Related Materials," for plastic domestic water piping components.
  - 2. Comply with NSF 61, "Drinking Water System Components - Health Effects; Sections 1 through 9."

## PART 2 - PRODUCTS

### 2.1 VACUUM BREAKERS

- A. Pipe-Applied, Atmospheric-Type Vacuum Breakers:
  - 1. Manufacturers: Subject to compliance with requirements, provide products by one of the following:
    - a. Ames Co.
    - b. Cash Acme.
    - c. Conbraco Industries, Inc.
    - d. FEBCO; SPX Valves & Controls.
    - e. Rain Bird Corporation.
    - f. Toro Company (The); Irrigation Div.
    - g. Watts Industries, Inc.; Water Products Div.
    - h. Zurn Plumbing Products Group; Wilkins Div.
  - 2. Standard: ASSE 1001.
  - 3. Size: NPS 1/4 to NPS 3, as required to match connected piping.
  - 4. Body: Bronze.
  - 5. Inlet and Outlet Connections: Threaded.
  - 6. Finish: Chrome plated.
- B. Hose-Connection Vacuum Breakers:
  - 1. Manufacturers: Subject to compliance with requirements, provide products by one of the following:
    - a. Arrowhead Brass Products, Inc.
    - b. Cash Acme.
    - c. Conbraco Industries, Inc.
    - d. Legend Valve.
    - e. MIFAB, Inc.



- f. Prier Products, Inc.
  - g. Watts Industries, Inc.; Water Products Div.
  - h. Woodford Manufacturing Company.
  - i. Zurn Plumbing Products Group; Light Commercial Operation.
  - j. Zurn Plumbing Products Group; Wilkins Div.
2. Standard: ASSE 1011.
  3. Body: Bronze, nonremovable, with manual drain.
  4. Outlet Connection: Garden-hose threaded complying with ASME B1.20.7.
  5. Finish: Chrome or nickel plated.
- C. Pressure Vacuum Breakers:
1. Manufacturers: Subject to compliance with requirements, provide products by one of the following:
    - a. Ames Co.
    - b. Conbraco Industries, Inc.
    - c. FEBCO; SPX Valves & Controls.
    - d. Flomatic Corporation.
    - e. Toro Company (The); Irrigation Div.
    - f. Watts Industries, Inc.; Water Products Div.
    - g. Zurn Plumbing Products Group; Wilkins Div.
  2. Standard: ASSE 1020.
  3. Operation: Continuous-pressure applications.
  4. Pressure Loss: 5 psig maximum, through middle 1/3 of flow range.
  5. Accessories:
    - a. Valves: Ball type, on inlet and outlet.
- D. Spill-Resistant Vacuum Breakers:
1. Manufacturers: Subject to compliance with requirements, provide products by one of the following:
    - a. Conbraco Industries, Inc.
    - b. Watts Industries, Inc.; Water Products Div.
  2. Standard: ASSE 1056.
  3. Operation: Continuous-pressure applications.
  4. Accessories:
    - a. Valves: Ball type, on inlet and outlet.

## 2.2 BACKFLOW PREVENTERS

### A. Reduced-Pressure-Principle Backflow Preventers:

1. Manufacturers: Subject to compliance with requirements, provide products by one of the following:

- a. Ames Co.
  - b. Conbraco Industries, Inc.
  - c. FEBCO; SPX Valves & Controls.
  - d. Flomatic Corporation.
  - e. Watts Industries, Inc.; Water Products Div.
  - f. Zurn Plumbing Products Group; Wilkins Div.
2. Standard: ASSE 1013.
  3. Operation: Continuous-pressure applications.
  4. Pressure Loss: 12 psig maximum, through middle 1/3 of flow range.
  5. Body: Bronze for NPS 2 and smaller; cast iron with interior lining complying with AWWA C550 or that is FDA approved] for NPS 2-1/2 and larger.
  6. End Connections: Threaded for NPS 2 and smaller; flanged for NPS 2-1/2 and larger.
  7. Accessories:
    - a. Valves: Ball type with threaded ends on inlet and outlet of NPS 2 and smaller; outside screw and yoke gate-type with flanged ends on inlet and outlet of NPS 2-1/2 and larger.
    - b. Air-Gap Fitting: ASME A112.1.2, matching backflow-preventer connection.
- B. Double-Check Backflow-Prevention Assemblies:
1. Manufacturers: Subject to compliance with requirements, provide products by one of the following:
    - a. Ames Co.
    - b. Conbraco Industries, Inc.
    - c. FEBCO; SPX Valves & Controls.
    - d. Flomatic Corporation.
    - e. Watts Industries, Inc.; Water Products Div.
    - f. Zurn Plumbing Products Group; Wilkins Div.
  2. Standard: ASSE 1015.
  3. Operation: Continuous-pressure applications, unless otherwise indicated.
  4. Pressure Loss: 5 psig maximum, through middle 1/3 of flow range.
  5. Body: Bronze for NPS 2 and smaller; cast iron with interior lining complying with AWWA C550 or that is FDA approved for NPS 2-1/2 and larger.
  6. End Connections: Threaded for NPS 2 and smaller; [flanged] <Insert type> for NPS 2-1/2 and larger.
  7. Accessories:
    - a. Valves: Ball type with threaded ends on inlet and outlet of NPS 2 and smaller; outside screw and yoke gate-type with flanged ends on inlet and outlet of NPS 2-1/2 and larger.
- C. Beverage-Dispensing-Equipment Backflow Preventers:
1. Manufacturers: Subject to compliance with requirements, provide products by one of the following:
    - a. Conbraco Industries, Inc.
    - b. Watts Industries, Inc.; Water Products Div.

- c. Zurn Plumbing Products Group; Wilkins Div.
  2. Standard: ASSE 1022.
  3. Operation: Continuous-pressure applications.
  4. Size: NPS 1/4 or NPS 3/8.
  5. Body: Stainless steel.
  6. End Connections: Threaded.
- D. Dual-Check-Valve Backflow Preventers:
1. Manufacturers: Subject to compliance with requirements, provide products by one of the following:
    - a. Cash Acme.
    - b. Conbraco Industries, Inc.
    - c. FEBCO; SPX Valves & Controls.
    - d. Flomatic Corporation.
    - e. Ford Meter Box Company, Inc. (The).
    - f. Honeywell Water Controls.
    - g. Legend Valve.
    - h. McDonald, A. Y. Mfg. Co.
    - i. Mueller Co.; Water Products Div.
    - j. Watts Industries, Inc.; Water Products Div.
    - k. Zurn Plumbing Products Group; Wilkins Div.
  2. Standard: ASSE 1024.
  3. Operation: Continuous-pressure applications.
  4. Body: Bronze with union inlet.
- E. Carbonated-Beverage-Dispenser, Dual-Check-Valve Backflow Preventers:
1. Manufacturers: Subject to compliance with requirements, provide products by one of the following:
    - a. Cash Acme.
    - b. Lancer Corporation.
    - c. Watts Industries, Inc.; Water Products Div.
  2. Standard: ASSE 1032.
  3. Operation: Continuous-pressure applications.
  4. Size: NPS 1/4 or NPS 3/8.
  5. Body: Stainless steel.
  6. End Connections: Threaded.

## 2.3 WATER PRESSURE-REDUCING VALVES

### A. Water Regulators: (Direct Type)

1. Manufacturers: Subject to compliance with requirements, provide products by one of the following:
  - a. Cash Acme.

- b. Conbraco Industries, Inc.
  - c. Honeywell Water Controls.
  - d. Watts Industries, Inc.; Water Products Div.
  - e. Zurn Plumbing Products Group; Wilkins Div.
2. Standard: ASSE 1003.
  3. Pressure Rating: Initial working pressure of 150 psig.
  4. Body: Bronze, provide chrome-plated finish if connected to chrome plated or stainless steel piping for NPS 2 and smaller; cast iron with interior lining complying with AWWA C550 or that is FDA approved for NPS 2-1/2 and NPS 3.
  5. Valves for Booster Heater Water Supply: Include integral bypass.
  6. End Connections: Threaded for NPS 2 and smaller; flanged for NPS 2-1/2 and NPS 3.
- B. Water Control Valves: (Pilot type)
1. Manufacturers: Subject to compliance with requirements, provide products by one of the following:
    - a. CLA-VAL Automatic Control Valves.
    - b. Mifab Corp; Beeco.
    - c. Watts Industries, Inc.; Ames Fluid Control Systems.
    - d. Watts Industries, Inc.; Watts ACV.
    - e. Zurn Plumbing Products Group; Wilkins Div.
  2. Description: Pilot-operation, diaphragm-type, single-seated main water control valve.
  3. Pressure Rating: Initial working pressure of 150 psig minimum with AWWA C550 or FDA-approved, interior epoxy coating. Include small pilot-control valve, restrictor device, specialty fittings, and sensor piping.
  4. Main Valve Body: Cast- or ductile-iron body with AWWA C550 or FDA-approved, interior epoxy coating; or stainless-steel body.
  5. End Connections: Threaded for NPS 2 and smaller; flanged for NPS 2-1/2 and larger.

## 2.4 BALANCING VALVES

- A. Copper-Alloy Calibrated Balancing Valves:
1. Manufacturers: Subject to compliance with requirements, provide products by one of the following:
    - a. Armstrong International, Inc.
    - b. Flo Fab Inc.
    - c. ITT Industries; Bell & Gossett Div.
    - d. NIBCO INC.
    - e. TAC Americas.
    - f. Taco, Inc.
    - g. Victaulic
    - h. Watts Industries, Inc.; Water Products Div.

2. Type: Ball or Y-pattern globe valve with two readout ports and memory setting indicator.
3. Body: bronze,
4. Size: Same as connected piping, but not larger than NPS 2.
5. Accessories: Meter hoses, fittings, valves, differential pressure meter, and carrying case.

B. Cast-Iron Calibrated Balancing Valves:

1. Manufacturers: Subject to compliance with requirements, provide products by one of the following:
  - a. Armstrong International, Inc.
  - b. Flo Fab Inc.
  - c. ITT Industries; Bell & Gossett Div.
  - d. NIBCO INC.
  - e. TAC Americas.
  - f. Watts Industries, Inc.; Water Products Div.
2. Type: Adjustable with Y-pattern globe valve, two readout ports, and memory-setting indicator.
3. Size: Same as connected piping, but not smaller than NPS 2-1/2.

C. Accessories: Meter hoses, fittings, valves, differential pressure meter, and carrying case.

## 2.5 TEMPERATURE-ACTUATED WATER MIXING VALVES

A. Water-Temperature Limiting Devices:

1. Manufacturers: Subject to compliance with requirements, provide products by one of the following:
  - a. Armstrong International, Inc.
  - b. Cash Acme.
  - c. Conbraco Industries, Inc.
  - d. Honeywell Water Controls.
  - e. Legend Valve.
  - f. Leonard Valve Company.
  - g. Powers; a Watts Industries Co.
  - h. Symmons Industries, Inc.
  - i. Taco, Inc.
  - j. Watts Industries, Inc.; Water Products Div.
  - k. Zurn Plumbing Products Group; Wilkins Div.
2. Standard: ASSE 1017.
3. Pressure Rating: 125 psig.
4. Type: Thermostatically controlled water mixing valve.
5. Material: Bronze body with corrosion-resistant interior components.
6. Connections: Threaded union inlets and outlet.
7. Accessories: Check stops on hot- and cold-water supplies, and adjustable, temperature-control handle.
8. Valve Finish: Rough bronze.

## B. Primary, Thermostatic, Water Mixing Valves:

1. Manufacturers: Subject to compliance with requirements, provide products by one of the following:
  - a. Armstrong International, Inc.
  - b. Lawler Manufacturing Company, Inc.
  - c. Leonard Valve Company.
  - d. Powers; a Watts Industries Co.
  - e. Symmons Industries, Inc.
2. Standard: ASSE 1017.
3. Pressure Rating: 125 psig.
4. Type: Exposed-mounting, thermostatically controlled water mixing valve.
5. Material: Bronze body with corrosion-resistant interior components.
6. Connections: Threaded union inlets and outlet.
7. Accessories: Manual temperature control, check stops on hot- and cold-water supplies, and adjustable, temperature-control handle.
8. Valve Pressure Rating: 125 psig minimum, unless otherwise indicated.
9. Valve Finish: Chrome plated.
10. Piping Finish: Copper.

## C. Individual-Fixture, Water Tempering Valves:

1. Manufacturers: Subject to compliance with requirements, provide products by one of the following:
  - a. Cash Acme.
  - b. Conbraco Industries, Inc.
  - c. Honeywell Water Controls.
  - d. Lawler Manufacturing Company, Inc.
  - e. Leonard Valve Company.
  - f. Powers; a Watts Industries Co.
  - g. Watts Industries, Inc.; Water Products Div.
  - h. Zurn Plumbing Products Group; Wilkins Div.
2. Standard: ASSE 1016, thermostatically controlled water tempering valve.
3. Pressure Rating: 125 psig minimum, unless otherwise indicated.
4. Body: Bronze body with corrosion-resistant interior components.
5. Temperature Control: Adjustable.
6. Inlets and Outlet: Threaded.
7. Finish: Rough or chrome-plated bronze.

## 2.6 STRAINERS FOR DOMESTIC WATER PIPING

## A. Y-Pattern Strainers:

1. Pressure Rating: 125 psig minimum, unless otherwise indicated.
2. Body: Bronze for NPS 2 and smaller; cast iron with interior lining complying with AWWA C550 or FDA-approved, epoxy coating and for NPS 2-1/2 and larger.
3. End Connections: Threaded for NPS 2 and smaller; flanged for NPS 2-1/2 and larger.

4. Screen: Stainless steel with round perforations, unless otherwise indicated.
5. Perforation Size:
  - a. Strainers NPS 2 and Smaller: 0.020 inch.
  - b. Strainers NPS 2-1/2 to NPS 4: 0.045 inch.
  - c. Strainers NPS 5 and Larger: 0.10 inch.
6. Drain: Factory-installed, hose-end drain valve.

## 2.7 OUTLET BOXES

### A. Icemaker Outlet Boxes:

1. Basis of Design: Guy Gray model FR1212SHACP fire rated washing machine box with one ¼ turn valve with water hammer arrestor and 1-1/2" drain connection.
2. Manufacturers: Subject to compliance with requirements, provide products by one of the following:
  - a. Acorn Engineering Company.
  - b. Guy Gray Manufacturing Co., Inc.
  - c. IPS Corporation.
  - d. LSP Products Group, Inc.
  - e. Oatey.
  - f. Plastic Oddities; a division of Diverse Corporate Technologies.
  - g. Symmons Industries, Inc.
  - h. Watts Industries, Inc.; Water Products Div.
  - i. Whitehall Manufacturing; a div. of Acorn Engineering Company.
  - j. Zurn Plumbing Products Group; Light Commercial Operation.
3. Mounting: Recessed.
4. Material and Finish: Enameled-steel or epoxy-painted-steel or plastic box and faceplate.
5. Faucet: Combination, valved fitting or separate hot- and cold-water, valved fittings complying with ASME A112.18.1. Include garden-hose thread complying with ASME B1.20.7 on outlets.
6. Supply Shutoff Fittings: NPS 1/2 gate, globe, or ball valves and NPS 1/2 copper, water tubing.
7. Drain: NPS 2 standpipe and P-trap for direct waste connection to drainage piping.
8. Inlet Hoses: Two 60-inch- long, rubber household clothes washer inlet hoses with female, garden-hose-thread couplings. Include rubber washers.
9. Drain Hose: One 48-inch- long, rubber household clothes washer drain hose with hooked end.

### B. Water Outlet Boxes:

1. Basis of Design: Water-Tite model W9200HA 6" diameter outlet box with ¼ turn valve and water hammer arrestor.
2. Manufacturers: Subject to compliance with requirements, provide products by one of the following:
  - a. Acorn Engineering Company.

- b. IPS Corporation.
  - c. LSP Products Group, Inc.
  - d. Oatey.
  - e. Plastic Oddities; a division of Diverse Corporate Technologies.
3. Mounting: Recessed.
  4. Material and Finish: Enameled-steel or epoxy-painted-steel or plastic box and faceplate.
  5. Faucet: Valved fitting complying with ASME A112.18.1. Include NPS 1/2 or smaller copper tube outlet.
  6. Supply Shutoff Fitting: NPS 1/2 gate, globe, or ball valve and NPS 1/2 copper, water tubing.

## 2.8 HOSE BIBBS

### A. Hose Bibbs:

1. Standard: ASME A112.18.1 for sediment faucets.
2. Body Material: Bronze.
3. Seat: Bronze, replaceable.
4. Supply Connections: NPS 1/2 or NPS 3/4 threaded or solder-joint inlet.
5. Outlet Connection: Garden-hose thread complying with ASME B1.20.7.
6. Pressure Rating: 125 psig.
7. Vacuum Breaker: Integral or field-installation, nonremovable, drainable, hose-connection vacuum breaker complying with ASSE 1011.
8. Finish for Equipment Rooms: Rough bronze, or chrome or nickel plated.
9. Finish for Service Areas: Chrome or nickel plated.
10. Finish for Finished Rooms: Chrome or nickel plated.
11. Operation for Equipment Rooms: Wheel handle or operating key.
12. Operation for Service Areas: Wheel handle.
13. Operation for Finished Rooms: Operating key.
14. Include operating key with each operating-key hose bibb.
15. Include integral wall flange with each chrome- or nickel-plated hose bibb.

## 2.9 DRAIN VALVES

### A. Ball-Valve-Type, Hose-End Drain Valves:

1. Standard: MSS SP-110 for standard-port, two-piece ball valves.
2. Pressure Rating: 400-psig minimum CWP.
3. Size: NPS 3/4.
4. Body: Copper alloy.
5. Ball: Chrome-plated brass.
6. Seats and Seals: Replaceable.
7. Handle: Vinyl-covered steel.
8. Inlet: Threaded or solder joint.
9. Outlet: Threaded, short nipple with garden-hose thread complying with ASME B1.20.7 and cap with brass chain.



## 2.10 WATER HAMMER ARRESTERS

## A. Water Hammer Arresters:

1. Manufacturers: Subject to compliance with requirements, provide products by one of the following:
  - a. AMTROL, Inc.
  - b. Josam Company.
  - c. MIFAB, Inc.
  - d. PPP Inc.
  - e. Sioux Chief Manufacturing Company, Inc.
  - f. Smith, Jay R. Mfg. Co.; Division of Smith Industries, Inc.
  - g. Tyler Pipe; Wade Div.
  - h. Watts Drainage Products Inc.
  - i. Zurn Plumbing Products Group; Specification Drainage Operation.
2. Standard: ASSE 1010 or PDI-WH 201.
3. Type: Metal bellows or Copper tube with piston.
4. Size: ASSE 1010, Sizes AA and A through F or PDI-WH 201, Sizes A through F.

## 2.11 TRAP-SEAL PRIMER VALVES

- A. TP-1 Trap Seal Primer Valves: ASSE 1018, water-supply-fed type, with the following characteristics:
1. 125-psig minimum working pressure.
  2. Bronze body with atmospheric-vented drain chamber.
  3. Inlet and Outlet Connections: 1/2-inch threaded, union, or solder joint.
  4. Gravity Drain Outlet Connection: 1/2-inch threaded or solder joint.
  5. Finish: Chrome plated, or rough bronze for units used with pipe or tube that is not chrome finished.

## PART 3 - EXECUTION

## 3.1 INSTALLATION

- A. Refer to Division 22 Section "Common Work Results for Plumbing" for piping joining materials, joint construction, and basic installation requirements.
- B. Install backflow preventers in each water supply to mechanical equipment and systems and to other equipment and water systems that may be sources of contamination. Comply with authorities having jurisdiction.
1. Locate backflow preventers in same room as connected equipment or system.
  2. Install drain for backflow preventers with atmospheric-vent drain connection with air-gap fitting, fixed air-gap fitting, or equivalent positive pipe separation of at least two pipe diameters in drain piping and pipe to floor drain. Locate air-gap device attached to or under backflow preventer. Simple air breaks are not acceptable for this application.

3. Do not install bypass piping around backflow preventers.
- C. Install water control valves with inlet and outlet shutoff valves. Install pressure gages on inlet and outlet.
- D. Install balancing valves in locations where they can easily be adjusted.
- E. Install temperature-actuated water mixing valves with check stops or shutoff valves on inlets and with shutoff valve on outlet.
  1. Install thermometers and water regulators if specified.
  2. Install cabinet-type units recessed in or surface mounted on wall as specified.
- F. Install Y-pattern strainers for water on supply side of each control valve, water pressure-reducing valve, solenoid valve, and pump.
- G. Install outlet boxes recessed in wall. Install 2-by-4-inch fire-retardant-treated-wood blocking wall reinforcement between studs. Fire-retardant-treated-wood blocking is specified in Division 06 Section "Rough Carpentry."
- H. Install water hammer arresters in water piping according to PDI-WH 201.
- I. Install supply-type, trap-seal primer valves with outlet piping pitched down toward drain trap a minimum of 1 percent, and connect to floor-drain body, trap, or inlet fitting. Adjust valve for proper flow.
- J. Install drainage-type, trap-seal primer valves as lavatory trap with outlet piping pitched down toward drain trap a minimum of 1 percent, and connect to floor-drain body, trap, or inlet fitting.
- K. Install trap-seal primer systems with outlet piping pitched down toward drain trap a minimum of 1 percent, and connect to floor-drain body, trap, or inlet fitting. Adjust system for proper flow.

### 3.2 CONNECTIONS

- A. Piping installation requirements are specified in other Division 22 Sections. Drawings indicate general arrangement of piping and specialties.
- B. Ground equipment according to Division 26 Section "Grounding and Bonding for Electrical Systems."
- C. Connect wiring according to Division 26 Section "Low-Voltage Electrical Power Conductors and Cables."

### 3.3 LABELING AND IDENTIFYING

- A. Equipment Nameplates and Signs: Install engraved plastic-laminate equipment nameplate or sign on or near each of the following:
  1. Pressure vacuum breakers.

2. Reduced-pressure-principle backflow preventers.
  3. Double-check backflow-prevention assemblies.
  4. Carbonated-beverage-machine backflow preventers.
  5. Dual-check-valve backflow preventers.
  6. Water pressure-reducing valves.
  7. Calibrated balancing valves.
  8. Primary, thermostatic, water mixing valves.
  9. Primary water tempering valves.
  10. Outlet boxes.
  11. Supply-type, trap-seal primer valves.
  12. Trap-seal primer systems.
- B. Distinguish among multiple units, inform operator of operational requirements, indicate safety and emergency precautions, and warn of hazards and improper operations, in addition to identifying unit. Nameplates and signs are specified in Division 22 Section "Identification for Plumbing Piping and Equipment."

### 3.4 FIELD QUALITY CONTROL

- A. Perform the following tests and prepare test reports:
1. Test each backflow preventer according to authorities having jurisdiction and the device's reference standard.
- B. Remove and replace malfunctioning domestic water piping specialties and retest as specified above.

### 3.5 ADJUSTING

- A. Set field-adjustable pressure set points of water pressure-reducing valves.
- B. Set field-adjustable flow set points of balancing valves.
- C. Set field-adjustable temperature set points of temperature-actuated water mixing valves.

END OF SECTION

**SECTION 22 13 16 - SANITARY WASTE AND VENT PIPING**

## PART 1 - GENERAL

## 1.1 RELATED DOCUMENTS

- A. Drawings and general provisions of the Contract, including General and Supplementary Conditions and Division 01 Specification Sections, apply to this Section.

## 1.2 SUMMARY

- A. Section Includes:
  - 1. Pipe, tube, and fittings.
  - 2. Specialty pipe fittings.

## 1.3 DEFINITIONS

- A. EPDM: Ethylene-propylene-diene terpolymer rubber.
- B. PVC: Polyvinyl chloride plastic.

## 1.4 PERFORMANCE REQUIREMENTS

- A. Components and installation shall be capable of withstanding the following minimum working pressure unless otherwise indicated:
  - 1. Soil, Waste, and Vent Piping: 10-foot head of water.
- B. Seismic Performance: Soil, waste, and vent piping and support and installation shall withstand the effects of earthquake motions determined according to SEI/ASCE 7 and with the requirements specified in Section 230548 "Vibration and Seismic Controls for HVAC."
  - 1. For piping with a seismic importance factor of 1.0 the term "withstand" means "the unit will remain in place without separation of any parts from the device when subjected to the seismic forces specified."
  - 2. For piping with a seismic importance factor of 1.5 the term "withstand" means "the unit will remain in place without separation of any parts from the device when subjected to the seismic forces specified and the unit will be fully operational after the seismic event."

## 1.5 ACTION SUBMITTALS

- A. Product Data: For each type of product indicated.

## 1.6 INFORMATIONAL SUBMITTALS

- A. Seismic Qualification Certificates: For waste and vent piping, accessories, and components, from manufacturer.
  - 1. Basis for Certification: Indicate whether withstand certification is based on actual test of assembled components or on calculation.
  - 2. Detailed description of piping anchorage devices on which the certification is based and their installation requirements.
- B. Field quality-control reports.

## 1.7 QUALITY ASSURANCE

- A. Piping materials shall bear label, stamp, or other markings of specified testing agency.
- B. Comply with NSF/ANSI 14, "Plastics Piping Systems Components and Related Materials," for plastic piping components. Include marking with "NSF-dwv" for plastic drain, waste, and vent piping; "NSF-sewer" for plastic sewer piping; "NSF-drain" for plastic drain piping, and "NSF-tubular" for plastic continuous waste piping.

## 1.8 PROJECT CONDITIONS

- A. Interruption of Existing Sanitary Waste Service: Do not interrupt service to facilities occupied by Owner or others unless permitted under the following conditions and then only after arranging to provide temporary service according to requirements indicated:
  - 1. Notify Construction Manager no fewer than two days in advance of proposed interruption of sanitary waste service.

## PART 2 - PRODUCTS

## 2.1 PIPING MATERIALS

- A. Comply with requirements in "Piping Schedule" Article for applications of pipe, tube, fitting materials, and joining methods for specific services, service locations, and pipe sizes.

## 2.2 HUBLESS, CAST-IRON SOIL PIPE AND FITTINGS

- A. Pipe and Fittings: All cast-iron waste, vent and sewer pipe and fittings shall conform to the requirements of CISPI Standard 301 and ASTM A 888. All products shall be marked with the collective trademark of the Cast Soil Pipe Institute and shall be listed by NSF International or receive prior approval of the engineer. All cast-iron pipe and fittings shall be American made and tested. Non-compliant import cast-iron products will not be permitted. Any non-compliant cast-iron product installed by the contractor on this project will be replaced at the contractor's expense and shall include all repairs,

patching, painting and other incidental work required to return the project to its pre-remediation state.

1. Manufacturers: Subject to compliance with requirements, provide products by one of the following:
  - a. AB&I Foundry
  - b. Charlotte Pipe
  - c. Tyler Pipe
  
- B. CISPI, Hubless-Piping Couplings:
  1. Manufacturers: Subject to compliance with requirements, provide products by one of the following:
    - a. ANACO.
    - b. Ideal
    - c. Mission Rubber Company; a division of MCP Industries, Inc.
    - d. Tyler Pipe.
  2. Standards: ASTM C 1277 and CISPI 310.
  3. Description: Stainless-steel corrugated shield with stainless-steel bands and tightening devices; and ASTM C 564, rubber sleeve with integral, center pipe stop.
  4. Listing: Couplings shall be listed by NSF International. Each coupling shall be embossed with the NSF seal.
  
- C. Heavy-Duty, Hubless-Piping Couplings:
  1. Manufacturers: Subject to compliance with requirements, provide products by one of the following:
    - a. Husky SD 4000.
    - b. Clamp-All Corp HI-TORQ 125.
  2. Standards: ASTM C 1277 and ASTM C 1540.
  3. Description: Stainless-steel shield with stainless-steel bands and tightening devices; and ASTM C 564, rubber sleeve with integral, center pipe stop.

## PART 3 - EXECUTION

### 3.1 PIPING INSTALLATION

- A. Drawing plans, schematics, and diagrams indicate general location and arrangement of piping systems. Indicated locations and arrangements were used to size pipe and calculate friction loss, expansion, pump sizing, and other design considerations. Install piping as indicated unless deviations to layout are approved on coordination drawings.
  
- B. Install piping in concealed locations unless otherwise indicated and except in equipment rooms and service areas.

- C. Install piping indicated to be exposed and piping in equipment rooms and service areas at right angles or parallel to building walls. Diagonal runs are prohibited unless specifically indicated otherwise.
- D. Install piping above accessible ceilings to allow sufficient space for ceiling panel removal.
- E. Install piping to permit valve servicing.
- F. Install piping at indicated slopes.
- G. Install piping free of sags and bends.
- H. Install fittings for changes in direction and branch connections.
- I. Install piping to allow application of insulation.
- J. Install seismic restraints on piping. Comply with SEI/ASCE 7 and with requirements for seismic-restraint devices specified in Division 22 Section "Vibration and Seismic Controls for Plumbing Piping and Equipment."
- K. Make changes in direction for soil and waste drainage and vent piping using appropriate branches, bends, and long-sweep bends. Sanitary tees and short-sweep 1/4 bends may be used on vertical stacks if change in direction of flow is from horizontal to vertical. Use long-turn, double Y-branch and 1/8-bend fittings if two fixtures are installed back to back or side by side with common drain pipe. Straight tees, elbows, and crosses may be used on vent lines. Do not change direction of flow more than 90 degrees. Use proper size of standard increasers and reducers if pipes of different sizes are connected. Reducing size of drainage piping in direction of flow is prohibited.
- L. Lay buried building drainage piping beginning at low point of each system. Install true to grades and alignment indicated, with unbroken continuity of invert. Place hub ends of piping upstream. Install required gaskets according to manufacturer's written instructions for use of lubricants, cements, and other installation requirements. Maintain swab in piping and pull past each joint as completed.
- M. Install soil and waste drainage and vent piping at the following minimum slopes unless otherwise indicated:
  - 1. Building Sanitary Drain: 2 percent downward in direction of flow for piping
  - 2. Horizontal Sanitary Drainage Piping: 2 percent downward in direction of flow.
  - 3. Vent Piping: 1 percent down toward vertical fixture vent or toward vent stack.
- N. Install cast-iron soil piping according to CISPI's "Cast Iron Soil Pipe and Fittings Handbook," Chapter IV, "Installation of Cast Iron Soil Pipe and Fittings."
  - 1. Install encasement on underground piping according to ASTM A 674 or AWWA C105/A 21.5.
- O. Install engineered soil and waste drainage and vent piping systems as follows:

1. Combination Waste and Vent: Comply with standards of authorities having jurisdiction.
- P. Plumbing Specialties:
1. Install cleanouts at grade and extend to where building sanitary drains connect to building sanitary sewers in sanitary drainage gravity-flow piping. Install cleanout fitting with closure plug inside the building in sanitary drainage force-main piping. Comply with requirements for cleanouts specified in Division 22 Section "Sanitary Waste Piping Specialties."
  2. Install drains in sanitary drainage gravity-flow piping. Comply with requirements for drains specified in Division 22 Section "Sanitary Waste Piping Specialties."
  3. Install cleanout fitting with closure plug inside the building in sanitary force-main piping.
- Q. Do not enclose, cover, or put piping into operation until it is inspected and approved by authorities having jurisdiction.
- R. Install sleeves for piping penetrations of walls, ceilings, and floors. Comply with requirements for sleeves specified in Division 22 Section "Sleeves and Sleeve Seals for Plumbing Piping."
- S. Install sleeve seals for piping penetrations of concrete walls and slabs. Comply with requirements for sleeve seals specified in Division 22 Section "Sleeves and Sleeve Seals for Plumbing Piping."
- T. Install escutcheons for piping penetrations of walls, ceilings, and floors. Comply with requirements for escutcheons specified in Division 22 Section "Escutcheons for Plumbing Piping."
- 3.2 JOINT CONSTRUCTION
- A. Join hubless, cast-iron soil piping according to CISPI 310 and CISPI's "Cast Iron Soil Pipe and Fittings Handbook" for hubless-piping coupling joints.
- 3.3 HANGER AND SUPPORT INSTALLATION
- A. Comply with requirements for seismic-restraint devices specified in Division 22 Section "Vibration and Seismic Controls for Plumbing Piping and Equipment."
- B. Comply with requirements for pipe hanger and support devices and installation specified in Division 22 Section "Hangers and Supports for Plumbing Piping and Equipment."
1. Install carbon-steel pipe hangers for horizontal piping in noncorrosive environments.
  2. Install stainless-steel pipe hangers for horizontal piping in corrosive environments.
  3. Install carbon-steel pipe support clamps for vertical piping in noncorrosive environments.
  4. Install stainless-steel pipe support clamps for vertical piping in corrosive environments.



5. Vertical Piping: MSS Type 8 or Type 42, clamps.
  6. Install individual, straight, horizontal piping runs:
    - a. 100 Feet and Less: MSS Type 1, adjustable, steel clevis hangers.
    - b. Longer Than 100 Feet: MSS Type 43, adjustable roller hangers.
    - c. Longer Than 100 Feet if Indicated: MSS Type 49, spring cushion rolls.
  7. Multiple, Straight, Horizontal Piping Runs 100 Feet or Longer: MSS Type 44, pipe rolls. Support pipe rolls on trapeze.
  8. Base of Vertical Piping: MSS Type 52, spring hangers.
- C. Support horizontal piping and tubing within 12 inches of each fitting and coupling or valve and coupling.
- D. Support vertical piping and tubing at base and at each floor.
- E. Rod diameter may be reduced one size for double-rod hangers, with 3/8-inch minimum rods.
- F. Install hangers for cast-iron soil piping with the following maximum horizontal spacing and minimum rod diameters:
1. NPS 1-1/2 and NPS 2: 60 inches with 3/8-inch rod.
  2. NPS 3: 60 inches with 1/2-inch rod.
  3. NPS 4 and NPS 5: 60 inches with 5/8-inch rod.
  4. NPS 6 and NPS 8: 60 inches with 3/4-inch rod.
  5. NPS 10 and NPS 12: 60 inches with 7/8-inch rod.
  6. Spacing for 10-foot lengths may be increased to 10 feet. Spacing for fittings is limited to 60 inches.
- G. Install supports for vertical cast-iron soil piping every 15 feet.
- H. Support piping and tubing not listed above according to MSS SP-69 and manufacturer's written instructions.

### 3.4 CONNECTIONS

- A. Drawings indicate general arrangement of piping, fittings, and specialties.
- B. Connect soil and waste piping to exterior sanitary sewerage piping. Use transition fitting to join dissimilar piping materials.
- C. Connect drainage and vent piping to the following:
1. Plumbing Fixtures: Connect drainage piping in sizes indicated, but not smaller than required by plumbing code.
  2. Plumbing Fixtures and Equipment: Connect atmospheric vent piping in sizes indicated, but not smaller than required by authorities having jurisdiction.
  3. Plumbing Specialties: Connect drainage and vent piping in sizes indicated, but not smaller than required by plumbing code.
  4. Install test tees (wall cleanouts) in conductors near floor and floor cleanouts with cover flush with floor.

5. Comply with requirements for cleanouts and drains specified in Division 22 Section "Sanitary Waste Piping Specialties."
  6. Equipment: Connect drainage piping as indicated. Provide shutoff valve if indicated and union for each connection. Use flanges instead of unions for connections NPS 2-1/2 and larger.
- D. Where installing piping adjacent to equipment, allow space for service and maintenance of equipment.
- E. Make fixture and equipment connections according to the following unless otherwise indicated:
1. Install unions, in piping NPS 2 and smaller, adjacent to each valve and at final connection to each piece of equipment.
  2. Install flanges, in piping NPS 2-1/2 and larger, adjacent to flanged valves and at final connection to each piece of equipment.

### 3.5 IDENTIFICATION

- A. Identify exposed sanitary waste and vent piping. Comply with requirements for identification specified in Division 22 Section "Identification for Plumbing Piping and Equipment."

### 3.6 FIELD QUALITY CONTROL

- A. During installation, notify authorities having jurisdiction at least 24 hours before inspection must be made. Perform tests specified below in presence of authorities having jurisdiction.
1. Roughing-in Inspection: Arrange for inspection of piping before concealing or closing-in after roughing-in and before setting fixtures.
  2. Final Inspection: Arrange for final inspection by authorities having jurisdiction to observe tests specified below and to ensure compliance with requirements.
- B. Reinspection: If authorities having jurisdiction find that piping will not pass test or inspection, make required corrections and arrange for reinspection.
- C. Reports: Prepare inspection reports and have them signed by authorities having jurisdiction.
- D. Test sanitary drainage and vent piping according to procedures of authorities having jurisdiction or, in absence of published procedures, as follows:
1. Test for leaks and defects in new piping and parts of existing piping that have been altered, extended, or repaired. If testing is performed in segments, submit separate report for each test, complete with diagram of portion of piping tested.
  2. Leave uncovered and unconcealed new, altered, extended, or replaced drainage and vent piping until it has been tested and approved. Expose work that was covered or concealed before it was tested.
  3. Roughing-in Plumbing Test Procedure: Test drainage and vent piping except outside leaders on completion of roughing-in. Close openings in piping system

and fill with water to point of overflow, but not less than 10-foot head of water. From 15 minutes before inspection starts to completion of inspection, water level must not drop. Inspect joints for leaks.

4. Finished Plumbing Test Procedure: After plumbing fixtures have been set and traps filled with water, test connections and prove they are gastight and watertight. Plug vent-stack openings on roof and building drains where they leave building. Introduce air into piping system equal to pressure of 1-inch wg. Use U-tube or manometer inserted in trap of water closet to measure this pressure. Air pressure must remain constant without introducing additional air throughout period of inspection. Inspect plumbing fixture connections for gas and water leaks.
5. Repair leaks and defects with new materials and retest piping, or portion thereof, until satisfactory results are obtained.
6. Prepare reports for tests and required corrective action.

### 3.7 CLEANING AND PROTECTION

- A. Clean interior of piping. Remove dirt and debris as work progresses.
- B. Protect drains during remainder of construction period to avoid clogging with dirt and debris and to prevent damage from traffic and construction work.
- C. Place plugs in ends of uncompleted piping at end of day and when work stops.

### 3.8 PIPING SCHEDULE

- A. Flanges and unions may be used on aboveground pressure piping unless otherwise indicated.
- B. Aboveground, soil and waste piping NPS 3 and smaller shall be the following:
  1. Hubless, cast-iron soil pipe and fittings CISPI hubless-piping couplings; and coupled joints.
  2. Dissimilar Pipe-Material Couplings: Shielded, nonpressure transition couplings.
- C. Aboveground, soil and waste piping NPS 4 and larger shall be the following:
  1. Hubless, cast-iron soil pipe and fittings heavy-duty hubless-piping couplings; and coupled joints.
  2. Dissimilar Pipe-Material Couplings: Shielded, nonpressure transition couplings.
- D. Aboveground, vent piping NPS 3 and smaller shall be the following:
  1. Hubless, cast-iron soil pipe and fittings CISPI hubless-piping couplings; and coupled joints.
  2. Dissimilar Pipe-Material Couplings: Shielded, nonpressure transition couplings.
- E. Aboveground, vent piping NPS 4 and larger shall be the following:
  1. Hubless, cast-iron soil pipe and fittings CISPI hubless-piping couplings; and coupled joints.

2. Dissimilar Pipe-Material Couplings: Unshielded, nonpressure transition couplings.

END OF SECTION

**SECTION 22 13 19 - SANITARY WASTE PIPING SPECIALTIES**

## PART 1 - GENERAL

## 1.1 RELATED DOCUMENTS

- A. Drawings and general provisions of the Contract, including General and Supplementary Conditions and Division 01 Specification Sections, apply to this Section.

## 1.2 SUMMARY

- A. This Section includes the following sanitary drainage piping specialties:
  - 1. Cleanouts.
  - 2. Floor drains.
  - 3. Through-penetration firestop assemblies.
  - 4. Miscellaneous sanitary drainage piping specialties.
- B. Related Sections include the following:
  - 1. Division 22 Section "Storm Drainage Piping Specialties" for trench drains for storm water, channel drainage systems for storm water, roof drains, and catch basins.

## 1.3 SEISMIC REQUIREMENTS

- A. Component Importance Factor. All plumbing components shall be assigned a component importance factor. The component importance factor,  $I_p$ , shall be taken as 1.5 if any of the following conditions apply:
  - 1. The component is required to function for life-safety purposes after an earthquake.
  - 2. The component contains hazardous materials.
  - 3. The component is in or attached to an Occupancy Category IV structure and it is needed for continued operation of the facility or its failure could impair the continued operation of the facility.
- B. All other components shall be assigned a component importance factor,  $I_p$ , equal to 1.0.
- C. Seismic Performance: Plumbing equipment, hangers and supports shall withstand the effects of earthquake motions determined according to SEI/ASCE 7 and with the requirements specified in Section 220548 "Vibration and Seismic Controls for Plumbing Piping and Equipment."

## 1.4 DEFINITIONS

- A. FOG: Fats, oils, and greases.

- B. FRP: Fiberglass-reinforced plastic.
- C. HDPE: High-density polyethylene plastic.
- D. PE: Polyethylene plastic.
- E. PP: Polypropylene plastic.
- F. PVC: Polyvinyl chloride plastic.

#### 1.5 SUBMITTALS

- A. Product Data: For each type of product indicated. Include rated capacities, operating characteristics, and accessories for the following:

#### 1.6 QUALITY ASSURANCE

- A. Drainage piping specialties shall bear label, stamp, or other markings of specified testing agency.
- B. Electrical Components, Devices, and Accessories: Listed and labeled as defined in NFPA 70, Article 100, by a testing agency acceptable to authorities having jurisdiction, and marked for intended use.

#### 1.7 COORDINATION

- A. Coordinate size and location of concrete bases. Cast anchor-bolt inserts into bases. Concrete, reinforcement, and formwork requirements are specified in Division 03.
- B. Coordinate size and location of roof penetrations.

### PART 2 - PRODUCTS

#### 2.1 CLEANOUTS

- A. Exposed Metal Cleanouts:
  - 1. Manufacturers: Subject to compliance with requirements, provide products by one of the following:
    - a. Josam Company; Josam Div.
    - b. MIFAB, Inc.
    - c. Smith, Jay R. Mfg. Co.; Division of Smith Industries, Inc.
    - d. Tyler Pipe; Wade Div.
    - e. Watts Drainage Products Inc.
    - f. Zurn Plumbing Products Group; Specification Drainage Operation.
  - 2. Standard: ASME A112.36.2M for cast iron for cleanout test tee.

3. Size: Same as connected drainage piping
4. Body Material: Hubless, cast-iron soil pipe test tee as required to match connected piping.
5. Closure: Countersunk, brass plug.
6. Closure Plug Size: Same as or not more than one size smaller than cleanout size.
7. Closure: Stainless-steel plug with seal.

B. Metal Floor Cleanouts:

1. Manufacturers: Subject to compliance with requirements, provide products by one of the following:
  - a. Josam Company; Josam Div.
  - b. Oatey.
  - c. Smith, Jay R. Mfg. Co.; Division of Smith Industries, Inc.
  - d. Tyler Pipe; Wade Div.
  - e. Watts Drainage Products Inc.
  - f. Zurn Plumbing Products Group; Light Commercial Operation.
  - g. Zurn Plumbing Products Group; Specification Drainage Operation.
2. Standard: ASME A112.36.2M for adjustable housing cleanout.
3. Size: Same as connected branch.
4. Type: Adjustable housing.
5. Body or Ferrule: Cast iron.
6. Clamping Device: Required.
7. Outlet Connection: Inside call.
8. Closure: Brass plug with tapered threads.
9. Adjustable Housing Material: Cast iron with threads.
10. Frame and Cover Material and Finish: Nickel-bronze, copper alloy.
11. Frame and Cover Shape: Round.
12. Top Loading Classification: Heavy Duty.
13. Riser: ASTM A 74, Service class, cast-iron drainage pipe fitting and riser to cleanout.
14. Standard: ASME A112.3.1.
15. Size: Same as connected branch.
16. Housing: Stainless steel.
17. Closure: Stainless steel with seal.
18. Riser: Stainless-steel drainage pipe fitting to cleanout.

C. Cast-Iron Wall Cleanouts:

1. Manufacturers: Subject to compliance with requirements, provide products by one of the following:
  - a. Josam Company; Josam Div.
  - b. MIFAB, Inc.
  - c. Smith, Jay R. Mfg. Co.; Division of Smith Industries, Inc.
  - d. Tyler Pipe; Wade Div.
  - e. Watts Drainage Products Inc.
  - f. Zurn Plumbing Products Group; Specification Drainage Operation.
2. Standard: ASME A112.36.2M. Include wall access.

3. Size: Same as connected drainage piping.
4. Body: Hub-and-spigot, cast-iron soil pipe T-branch as required to match connected piping.
5. Closure: Countersunk, brass plug.
6. Closure Plug Size: Same as or not more than one size smaller than cleanout size.
7. Wall Access: Round, flat, chrome-plated brass or stainless-steel cover plate with screw.
8. Wall Access: Round, stainless-steel wall-installation frame and cover.

## 2.2 FLOOR DRAINS

### A. Cast-Iron Floor Drains:

1. Manufacturers: Subject to compliance with requirements, provide products by one of the following:
2. Basis-of-Design Product: See Schedule at end of this Section:
  - a. Josam Company; Josam Div.
  - b. MIFAB, Inc.
  - c. Smith, Jay R. Mfg. Co.; Division of Smith Industries, Inc.
  - d. Tyler Pipe; Wade Div.
  - e. Watts Drainage Products Inc.
  - f. Zurn Plumbing Products Group; Specification Drainage Operation.
3. Standard: ASME A112.6.3.
4. Body Material: Gray iron.
5. Seepage Flange: Required.
6. Anchor Flange: Not required.
7. Outlet: Bottom.
8. Trap Material: Cast iron>.
9. Trap Pattern: Deep-seal P-trap>.
10. Trap Features: Trap-seal primer valve drain connection>.

## 2.3 THROUGH-PENETRATION FIRESTOP ASSEMBLIES

### A. Through-Penetration Firestop Assemblies:

1. Available Manufacturers: Subject to compliance with requirements, manufacturers offering products that may be incorporated into the Work include, but are not limited to, the following:
2. Manufacturers: Subject to compliance with requirements, provide products by one of the following:
  - a. ProSet Systems Inc.
3. Standard: UL 1479 assembly of sleeve and stack fitting with firestopping plug.
4. Size: Same as connected soil, waste, or vent stack.
5. Sleeve: Molded PVC plastic, of length to match slab thickness and with integral nailing flange on one end for installation in cast-in-place concrete slabs.



6. Stack Fitting: ASTM A 48/A 48M, gray-iron, hubless-pattern, wye branch with neoprene O-ring at base and gray-iron plug in thermal-release harness. Include PVC protective cap for plug.
7. Special Coating: Corrosion resistant on interior of fittings.

## 2.4 MISCELLANEOUS SANITARY DRAINAGE PIPING SPECIALTIES

### A. Deep-Seal Traps:

1. Description: Cast-iron or bronze casting, with inlet and outlet matching connected piping and cleanout trap-seal primer valve connection.
2. Size: Same as connected waste piping.
  - a. NPS 2: 4-inch- minimum water seal.
  - b. NPS 2-1/2 and Larger: 5-inch- minimum water seal.

### B. Floor-Drain, Trap-Seal Primer Fittings:

1. Description: Cast iron, with threaded inlet and threaded or spigot outlet, and trap-seal primer valve connection.
2. Size: Same as floor drain outlet with NPS 1/2 side inlet.

### C. Air-Gap Fittings:

1. Standard: ASME A112.1.2, for fitting designed to ensure fixed, positive air gap between installed inlet and outlet piping.
2. Body: Bronze or cast iron.
3. Inlet: Opening in top of body.
4. Outlet: Larger than inlet.
5. Size: Same as connected waste piping and with inlet large enough for associated indirect waste piping.

### D. Sleeve Flashing Device:

1. Description: Manufactured, cast-iron fitting, with clamping device, that forms sleeve for pipe floor penetrations of floor membrane. Include galvanized-steel pipe extension in top of fitting that will extend 1 inch > above finished floor and galvanized-steel pipe extension in bottom of fitting that will extend through floor slab.
2. Size: As required for close fit to riser or stack piping.

## 2.5 MOTORS

### A. General requirements for motors are specified in Division 22 Section "Common Motor Requirements for Plumbing Equipment."

1. Motor Sizes: Minimum size as indicated. If not indicated, large enough so driven load will not require motor to operate in service factor range above 1.0.
2. Controllers, Electrical Devices, and Wiring: Electrical devices and connections are specified in Division 26 Sections.

## PART 3 - EXECUTION

## 3.1 INSTALLATION

- A. Comply with requirements for seismic-restraint devices in Section 220548 "Vibration and Seismic Controls for Plumbing Piping and Equipment."
- B. Refer to Division 22 Section "Common Work Results for Plumbing" for piping joining materials, joint construction, and basic installation requirements.
- C. Install cleanouts in aboveground piping and building drain piping according to the following, unless otherwise indicated:
  - 1. Size same as drainage piping up to NPS 4. Use NPS 4 for larger drainage piping unless larger cleanout is indicated.
  - 2. Locate at each change in direction of piping greater than 45 degrees.
  - 3. Locate at minimum intervals of 50 feet for piping NPS 4 and smaller and 100 feet for larger piping.
  - 4. Locate at base of each vertical soil and waste stack.
- D. For floor cleanouts for piping below floors, install cleanout deck plates with top flush with finished floor.
- E. For cleanouts located in concealed piping, install cleanout wall access covers, of types indicated, with frame and cover flush with finished wall.
- F. Install floor drains at low points of surface areas to be drained. Set grates of drains flush with finished floor, unless otherwise indicated.
  - 1. Position floor drains for easy access and maintenance.
  - 2. Set floor drains below elevation of surrounding finished floor to allow floor drainage. Set with grates depressed according to the following drainage area radii:
    - a. Radius, 30 Inches or Less: Equivalent to 1 percent slope, but not less than 1/4-inch total depression.
    - b. Radius, 30 to 60 Inches: Equivalent to 1 percent slope.
    - c. Radius, 60 Inches or Larger: Equivalent to 1 percent slope, but not greater than 1-inch total depression.
  - 3. Install floor-drain flashing collar or flange so no leakage occurs between drain and adjoining flooring. Maintain integrity of waterproof membranes where penetrated.
  - 4. Install individual traps for floor drains connected to sanitary building drain, unless otherwise indicated.
- G. Assemble plastic channel drainage system components according to manufacturer's written instructions. Install on support devices so that top will be flush with adjacent surface.
- H. Install deep-seal traps on floor drains and other waste outlets, if indicated.

- I. Install floor-drain, trap-seal primer fittings on inlet to floor drains that require trap-seal primer connection.
  - 1. Exception: Fitting may be omitted if trap has trap-seal primer connection.
  - 2. Size: Same as floor drain inlet.
- J. Install air-gap fittings on draining-type backflow preventers and on indirect-waste piping discharge into sanitary drainage system.
- K. Install sleeve flashing device with each riser and stack passing through floors with waterproof membrane.
- L. Install wood-blocking reinforcement for wall-mounting-type specialties.
- M. Install traps on plumbing specialty drain outlets. Omit traps on indirect wastes unless trap is indicated.
- N. Install escutcheons at wall, floor, and ceiling penetrations in exposed finished locations and within cabinets and millwork. Use deep-pattern escutcheons if required to conceal protruding pipe fittings.

### 3.2 CONNECTIONS

- A. Piping installation requirements are specified in other Division 22 Sections. Drawings indicate general arrangement of piping, fittings, and specialties.
- B. Install piping adjacent to equipment to allow service and maintenance.
- C. Ground equipment according to Division 26 Section "Grounding and Bonding for Electrical Systems."
- D. Connect wiring according to Division 26 Section "Low-Voltage Electrical Power Conductors and Cables."

### 3.3 FIELD QUALITY CONTROL

- A. Perform tests and inspections and prepare test reports.
  - 1. Manufacturer's Field Service: Engage a factory-authorized service representative to inspect field-assembled grease removal devices and their installation, including piping and electrical connections, and to assist in testing.
- B. Tests and Inspections:
  - 1. Leak Test: After installation, charge system and test for leaks. Repair leaks and retest until no leaks exist.
  - 2. Test and adjust controls and safeties. Replace damaged and malfunctioning controls and equipment.

3.4 PROTECTION

- A. Protect drains during remainder of construction period to avoid clogging with dirt or debris and to prevent damage from traffic or construction work.
- B. Place plugs in ends of uncompleted piping at end of each day or when work stops.

3.5 DEMONSTRATION

- A. Engage a factory-authorized service representative to train Owner's maintenance personnel to adjust, operate, and maintain grease removal devices. Refer to Division 01 Section "Demonstration and Training."

END OF SECTION

**SECTION 22 40 00 - PLUMBING FIXTURES**

## PART 1 - GENERAL

## 1.1 RELATED DOCUMENTS

- A. Drawings and general provisions of the Contract, including General and Supplementary Conditions and Division 01 Specification Sections, apply to this Section.

## 1.2 SUMMARY

- A. This Section includes the following conventional plumbing fixtures and related components:

1. Faucets for lavatories showers and sinks.
2. Flushometers.
3. Toilet seats.
4. Protective shielding guards.
5. Fixture supports.
6. Water closets.
7. Urinals.
8. Lavatories.
9. Commercial sinks.
10. Service sinks.

- B. :

1. Division 10 Section "Toilet, Bath, and Laundry Accessories."
2. Division 22 Section "Domestic Water Piping Specialties" for backflow preventers, floor drains, and specialty fixtures not included in this Section.
3. Division 22 Section "Emergency Plumbing Fixtures."
4. Division 22 Section "Drinking Fountains and Water Coolers."

## 1.3 DEFINITIONS

- A. Accessible Fixture: Plumbing fixture that can be approached, entered, and used by people with disabilities.
- B. Cast Polymer: Cast-filled-polymer-plastic material. This material includes cultured-marble and solid-surface materials.
- C. Cultured Marble: Cast-filled-polymer-plastic material with surface coating.
- D. Fitting: Device that controls the flow of water into or out of the plumbing fixture. Fittings specified in this Section include supplies and stops, faucets and spouts, shower heads and tub spouts, drains and tailpieces, and traps and waste pipes. Piping and general-duty valves are included where indicated.
- E. FRP: Fiberglass-reinforced plastic.

- F. PMMA: Polymethyl methacrylate (acrylic) plastic.
- G. PVC: Polyvinyl chloride plastic.
- H. Solid Surface: Nonporous, homogeneous, cast-polymer-plastic material with heat-, impact-, scratch-, and stain-resistance qualities.

#### 1.4 SUBMITTALS

- A. Product Data: For each type of plumbing fixture indicated. Include selected fixture and trim, fittings, accessories, appliances, appurtenances, equipment, and supports. Indicate materials and finishes, dimensions, construction details, and flow-control rates.
- B. Shop Drawings: Diagram power, signal, and control wiring.
- C. Operation and Maintenance Data: For plumbing fixtures to include in emergency, operation, and maintenance manuals.
- D. Warranty: Special warranty specified in this Section.

#### 1.5 QUALITY ASSURANCE

- A. Source Limitations: Obtain plumbing fixtures, faucets, and other components of each category through one source from a single manufacturer.
  - 1. Exception: If fixtures, faucets, or other components are not available from a single manufacturer, obtain similar products from other manufacturers specified for that category.
- B. Electrical Components, Devices, and Accessories: Listed and labeled as defined in NFPA 70, Article 100, by a testing agency acceptable to authorities having jurisdiction, and marked for intended use.
- C. Regulatory Requirements: Comply with requirements in ICC A117.1, "Accessible and Usable Buildings and Facilities"; Public Law 90-480, "Architectural Barriers Act"; and Public Law 101-336, "Americans with Disabilities Act"; for plumbing fixtures for people with disabilities.
- D. Regulatory Requirements: Comply with requirements in Public Law 102-486, "Energy Policy Act," about water flow and consumption rates for plumbing fixtures.
- E. NSF Standard: Comply with NSF 61, "Drinking Water System Components--Health Effects," for fixture materials that will be in contact with potable water.
- F. Select combinations of fixtures and trim, faucets, fittings, and other components that are compatible.
- G. Comply with the following applicable standards and other requirements specified for plumbing fixtures:
  - 1. Enameled, Cast-Iron Fixtures: ASME A112.19.1M.

2. Porcelain-Enameled, Formed-Steel Fixtures: ASME A112.19.4M.
  3. Slip-Resistant Bathing Surfaces: ASTM F 462.
  4. Solid-Surface-Material Lavatories and Sinks: ANSI/ICPA SS-1.
  5. Stainless-Steel Residential Sinks: ASME A112.19.3.
  6. Vitreous-China Fixtures: ASME A112.19.2M.
  7. Water-Closet, Flushometer Tank Trim: ASSE 1037.
  8. Whirlpool Bathtub Fittings: ASME A112.19.8M.
- H. Comply with the following applicable standards and other requirements specified for lavatory and sink faucets:
1. Backflow Protection Devices for Faucets with Side Spray: ASME A112.18.3M.
  2. Backflow Protection Devices for Faucets with Hose-Thread Outlet: ASME A112.18.3M.
  3. Diverter Valves for Faucets with Hose Spray: ASSE 1025.
  4. Faucets: ASME A112.18.1.
  5. Hose-Connection Vacuum Breakers: ASSE 1011.
  6. Hose-Coupling Threads: ASME B1.20.7.
  7. Integral, Atmospheric Vacuum Breakers: ASSE 1001.
  8. NSF Potable-Water Materials: NSF 61.
  9. Pipe Threads: ASME B1.20.1.
  10. Sensor-Actuated Faucets and Electrical Devices: UL 1951.
  11. Supply Fittings: ASME A112.18.1.
  12. Brass Waste Fittings: ASME A112.18.2.
  13. NSF61 Appendage G-AB 1953. Lead free potable drinking faucets.
- I. Comply with the following applicable standards and other requirements specified for bathtub/shower and shower faucets:
1. Backflow Protection Devices for Hand-Held Showers: ASME A112.18.3M.
  2. Combination, Pressure-Equalizing and Thermostatic-Control Antiscald Faucets: ASSE 1016.
  3. Deck-Mounted Bath/Shower Transfer Valves: ASME 18.7.
  4. Faucets: ASME A112.18.1.
  5. Hand-Held Showers: ASSE 1014.
  6. High-Temperature-Limit Controls for Thermal-Shock-Preventing Devices: ASTM F 445.
  7. Hose-Coupling Threads: ASME B1.20.7.
  8. Manual-Control Antiscald Faucets: ASTM F 444.
  9. Pipe Threads: ASME B1.20.1.
  10. Pressure-Equalizing-Control Antiscald Faucets: ASTM F 444 and ASSE 1016.
  11. Sensor-Actuated Faucets and Electrical Devices: UL 1951.
  12. Thermostatic-Control Antiscald Faucets: ASTM F 444 and ASSE 1016.
- J. Comply with the following applicable standards and other requirements specified for miscellaneous fittings:
1. Atmospheric Vacuum Breakers: ASSE 1001.
  2. Brass and Copper Supplies: ASME A112.18.1.
  3. Dishwasher Air-Gap Fittings: ASSE 1021.
  4. Manual-Operation Flushometers: ASSE 1037.
  5. Plastic Tubular Fittings: ASTM F 409.

6. Brass Waste Fittings: ASME A112.18.2.
7. Sensor-Operation Flushometers: ASSE 1037 and UL 1951.
8. NSF61 Appendage G-AB 1953. Lead free potable drinking faucets.

K. Comply with the following applicable standards and other requirements specified for miscellaneous components:

1. Disposers: ASSE 1008 and UL 430.
2. Dishwasher Air-Gap Fittings: ASSE 1021.
3. Flexible Water Connectors: ASME A112.18.6.
4. Floor Drains: ASME A112.6.3.
5. Grab Bars: ASTM F 446.
6. Hose-Coupling Threads: ASME B1.20.7.
7. Off-Floor Fixture Supports: ASME A112.6.1M.
8. Pipe Threads: ASME B1.20.1.
9. Plastic Toilet Seats: ANSI Z124.5.
10. Supply and Drain Protective Shielding Guards: ICC A117.1.

## 1.6 EXTRA MATERIALS

A. Furnish extra materials described below that match products installed and that are packaged with protective covering for storage and identified with labels describing contents.

1. Faucet Washers and O-Rings: Equal to 10 percent of amount of each type and size installed.
2. Faucet Cartridges and O-Rings: Equal to 5 percent of amount of each type and size installed.
3. Flushometer Valve, Repair Kits: Equal to 10 percent of amount of each type installed, but no fewer than 12 of each type.
4. Provide hinged-top wood or metal box, or individual metal boxes, with separate compartments for each type and size of extra materials listed above.
5. Toilet Seats: Equal to 5 percent of amount of each type installed.

## PART 2 - PRODUCTS

### 2.1 LAVATORY FAUCETS

A. Lavatory Faucets:

1. Manufacturers: Subject to compliance with requirements, provide products by one of the following:
  - a. Chicago Faucets.
  - b. T & S Brass and Bronze Works, Inc.

### 2.2 SHOWER FAUCETS

A. Shower Faucets:



1. Manufacturers: Subject to compliance with requirements, provide products by one of the following:
  - a. Chicago Faucets.
  - b. Leonard Valve Company.
  - c. Powers; a Watts Industries Co.
  - d. Symmons Industries, Inc.
  - e. T & S Brass and Bronze Works, Inc.

## 2.3 SINK FAUCETS

### A. Sink Faucets:

1. Manufacturers: Subject to compliance with requirements, provide products by one of the following:
  - a. Chicago Faucets.
  - b. T & S Brass and Bronze Works, Inc.

## 2.4 FLUSHOMETERS

### A. Flushometers:

1. Manufacturers: Subject to compliance with requirements, provide products by one of the following:
  - a. Sloan Valve Company.
  - b. Zurn Plumbing Products Group; Commercial Brass Operation.
  - c. Moen, Inc.

## 2.5 TOILET SEATS

### A. Toilet Seats:

1. Manufacturers: Subject to compliance with requirements, provide products by one of the following:
  - a. Bemis Manufacturing Company.
  - b. American Standard
  - c. Centoco Manufacturing Corp.
  - d. Church Seats.
  - e. Olsonite Corp.
  - f. Sperzel.
2. Description: Toilet seat for water-closet-type fixture.
  - a. Material: Molded, solid plastic with antimicrobial agent.
  - b. Configuration: Open front without cover.
  - c. Size: Elongated.

- d. Hinge Type: CK, check.
- e. Class: Heavy-duty commercial.
- f. Color: White.

## 2.6 PROTECTIVE SHIELDING GUARDS

### A. Protective Shielding Pipe Covers:

1. Manufacturers: Subject to compliance with requirements, provide products by one of the following:
  - a. Engineered Brass Co.
  - b. Insul-Tect Products Co.; a Subsidiary of MVG Molded Products.
  - c. McGuire Manufacturing Co., Inc.
  - d. Plumberex Specialty Products Inc.
  - e. TCI Products.
  - f. TRUEBRO, Inc.
  - g. Zurn Plumbing Products Group; Tubular Brass Plumbing Products Operation.
2. Description: Manufactured plastic wraps for covering plumbing fixture hot- and cold-water supplies and trap and drain piping. Comply with Americans with Disabilities Act (ADA) requirements. Product shall also meet the ASTM E 84 25/450 smoke and flame rating.

### B. Protective Shielding Piping Enclosures:

1. Manufacturers: Subject to compliance with requirements, provide products by one of the following:
  - a. TRUEBRO, Inc.
2. Description: Manufactured plastic enclosure for covering plumbing fixture hot- and cold-water supplies and trap and drain piping. Comply with ADA requirements.

## 2.7 FIXTURE SUPPORTS

### A. Manufacturers: Subject to compliance with requirements, provide products by one of the following:

1. Josam Company.
2. MIFAB Manufacturing Inc.
3. Smith, Jay R. Mfg. Co.
4. Tyler Pipe; Wade Div.
5. Watts Drainage Products Inc.; a div. of Watts Industries, Inc.
6. Zurn Plumbing Products Group; Specification Drainage Operation.

### B. Urinal Supports:

1. Description: Type I, urinal carrier with fixture support plates and coupling with seal and fixture bolts and hardware matching fixture for wall-mounting, urinal-type fixture. Include steel uprights with feet.
2. Accessible-Fixture Support: Include rectangular steel uprights.

C. Lavatory Supports:

1. Description: Type II, lavatory carrier with concealed arms and tie rod for wall-mounting, lavatory-type fixture. Include steel uprights with feet.
2. Accessible-Fixture Support: Include rectangular steel uprights.

## 2.8 WATER CLOSETS

A. Water Closets:

1. Manufacturers: Subject to compliance with requirements, provide products by one of the following:
  - a. American Standard Companies, Inc.
  - b. Crane Plumbing, L.L.C./Fiat Products.
  - c. Eljer.
  - d. Kohler Co.

## 2.9 URINALS

A. Urinals:

1. Manufacturers: Subject to compliance with requirements, provide products by one of the following:
  - a. American Standard Companies, Inc.
  - b. Briggs Plumbing Products, Inc.
  - c. Crane Plumbing, L.L.C./Fiat Products.
  - d. Eljer.
  - e. Kohler Co.

## 2.10 LAVATORIES

A. Lavatories:

1. Manufacturers: Subject to compliance with requirements, provide products by one of the following:
  - a. American Standard Companies, Inc.
  - b. Briggs Plumbing Products, Inc.
  - c. Crane Plumbing, L.L.C./Fiat Products.
  - d. Eljer.
  - e. Kohler Co.

## 2.11 COMMERCIAL SINKS

## A. Commercial Sinks:

1. Manufacturers: Subject to compliance with requirements, provide products by one of the following:
  - a. Elkay Manufacturing Co.
  - b. Just Manufacturing Company.

## 2.12 SERVICE SINKS

## A. Service Sinks:

1. Manufacturers: Subject to compliance with requirements, provide products by one of the following:
  - a. American Standard Companies, Inc.
  - b. Commercial Enameling Company.
  - c. Eljer.
  - d. Kohler Co.
  - e. Crane Plumbing, L.L.C./Fiat Products.

## PART 3 - EXECUTION

## 3.1 EXAMINATION

- A. Examine roughing-in of water supply and sanitary drainage and vent piping systems to verify actual locations of piping connections before plumbing fixture installation.
- B. Examine cabinets, counters, floors, and walls for suitable conditions where fixtures will be installed.
- C. Proceed with installation only after unsatisfactory conditions have been corrected.

## 3.2 INSTALLATION

- A. Assemble plumbing fixtures, trim, fittings, and other components according to manufacturers' written instructions.
- B. Install off-floor supports, affixed to building substrate, for wall-mounting fixtures.
  1. Use carrier supports with waste fitting and seal for back-outlet fixtures.
  2. Use carrier supports without waste fitting for fixtures with tubular waste piping.
  3. Use chair-type carrier supports with rectangular steel uprights for accessible fixtures.
- C. Install back-outlet, wall-mounting fixtures onto waste fitting seals and attach to supports.

- D. Install floor-mounting fixtures on closet flanges or other attachments to piping or building substrate.
- E. Install wall-mounting fixtures with tubular waste piping attached to supports.
- F. Install counter-mounting fixtures in and attached to casework.
- G. Install fixtures level and plumb according to roughing-in drawings.
- H. Install water-supply piping with stop on each supply to each fixture to be connected to water distribution piping. Attach supplies to supports or substrate within pipe spaces behind fixtures. Install stops in locations where they can be easily reached for operation.
  - 1. Exception: Use ball, gate, or globe valves if supply stops are not specified with fixture. Valves are specified in Division 22 Section "General-Duty Valves for Plumbing Piping."
- I. Install trap and tubular waste piping on drain outlet of each fixture to be directly connected to sanitary drainage system.
- J. Install tubular waste piping on drain outlet of each fixture to be indirectly connected to drainage system.
- K. Install flushometer valves for accessible water closets and urinals with handle mounted on wide side of compartment. Install other actuators in locations that are easy for people with disabilities to reach.
- L. Install toilet seats on water closets.
- M. Install faucet-spout fittings with specified flow rates and patterns in faucet spouts if faucets are not available with required rates and patterns. Include adapters if required.
- N. Install water-supply flow-control fittings with specified flow rates in fixture supplies at stop valves.
- O. Install faucet flow-control fittings with specified flow rates and patterns in faucet spouts if faucets are not available with required rates and patterns. Include adapters if required.
- P. Install shower flow-control fittings with specified maximum flow rates in shower arms.
- Q. Install traps on fixture outlets.
  - 1. Exception: Omit trap on fixtures with integral traps.
  - 2. Exception: Omit trap on indirect wastes, unless otherwise indicated.
- R. Install escutcheons at piping wall ceiling penetrations in exposed, finished locations and within cabinets and millwork. Use deep-pattern escutcheons if required to conceal protruding fittings. Escutcheons are specified in Division 22 Section "Common Work Results for Plumbing."

- S. Set service basins in leveling bed of cement grout. Grout is specified in Division 22 Section "Common Work Results for Plumbing."
- T. Seal joints between fixtures and walls, floors, and countertops using sanitary-type, one-part, mildew-resistant silicone sealant. Match sealant color to fixture color. Sealants are specified in Division 07 Section "Joint Sealants."
- U. All plumbing fixtures are to be mounted at the height specified on the Architectural drawings.

### 3.3 CONNECTIONS

- A. Piping installation requirements are specified in other Division 22 Sections. Drawings indicate general arrangement of piping, fittings, and specialties.
- B. Connect fixtures with water supplies, stops, and risers, and with traps, soil, waste, and vent piping. Use size fittings required to match fixtures.
- C. Ground equipment according to Division 26 Section "Grounding and Bonding for Electrical Systems."
- D. Connect wiring according to Division 26 Section "Low-Voltage Electrical Power Conductors and Cables."

### 3.4 FIELD QUALITY CONTROL

- A. Verify that installed plumbing fixtures are categories and types specified for locations where installed.
- B. Check that plumbing fixtures are complete with trim, faucets, fittings, and other specified components.
- C. Inspect installed plumbing fixtures for damage. Replace damaged fixtures and components.
- D. Test installed fixtures after water systems are pressurized for proper operation. Replace malfunctioning fixtures and components, then retest. Repeat procedure until units operate properly.
- E. Install fresh batteries in sensor-operated mechanisms.

### 3.5 ADJUSTING

- A. Operate and adjust faucets and controls. Replace damaged and malfunctioning fixtures, fittings, and controls.
- B. Adjust water pressure at faucets and flushometer valves to produce proper flow and stream.
- C. Replace washers and seals of leaking and dripping faucets and stops.

- D. Install fresh batteries in sensor-operated mechanisms.

### 3.6 CLEANING

- A. Clean fixtures, faucets, and other fittings with manufacturers' recommended cleaning methods and materials. Do the following:
  - 1. Remove faucet spouts and strainers, remove sediment and debris, and reinstall strainers and spouts.
  - 2. Remove sediment and debris from drains.
- B. After completing installation of exposed, factory-finished fixtures, faucets, and fittings, inspect exposed finishes and repair damaged finishes.

### 3.7 PROTECTION

- A. Provide protective covering for installed fixtures and fittings.
- B. Do not allow use of plumbing fixtures for temporary facilities unless approved in writing by Owner.

END OF SECTION

**SECTION 22 63 14 - MEDICAL GAS PIPING**

## PART 1 - GENERAL

## 1.1 RELATED DOCUMENTS

- A. Drawings and general provisions of the Contract, including General and Supplementary Conditions and Division 1 Specification Sections, apply to this Section.

## 1.2 SUMMARY

- A. This Section includes piping and related specialties for the following medical gas systems:
1. Oxygen piping, designated "oxygen," OX.
  2. Medical compressed-air piping, designated "medical air, MA.
  3. Nitrous-oxide piping, designated "nitrous oxide," NO or N2O.
  4. Nitrogen piping, designated "nitrogen," N or N2.
  5. Carbon-dioxide piping, designated "carbon dioxide" or CO2.
  6. Medical-surgical vacuum piping, designated "medical vacuum," V or MV.
  7. Waste anesthetic gas disposal piping, designated "evacuation," EV or EVAC.
- B. Contractor furnished products and services.
1. All materials – piping, fittings, hangers, labeling, etc. that are not owner-furnished required by contract documents NFPA 99, for a complete system.
  2. Medical gas equipment and specialties including, but not limited to, valves, valve boxes, pressure controllers, pressure sensors, alarm panels, manifolds, emergency O2 connections, wall outlets, and ceiling-service hose drops.
  3. The entire medical gas system shall, upon successful completion of Installer Performed Tests, be verified by an independent verifier provided by Allied Healthcare Products, Inc.
  4. Verifier shall perform all tests required by NFPA 99 and all federal, state and local requirements, and submit results to the mechanical contractor for distribution to the general contractor, mechanical/plumbing engineer/s, owner, and others as directed by the project engineer.
- C. The following products will be furnished by the owner under a Hospital Equipment contract:
1. Medical gas equipment such as ceiling booms, ceiling columns, floor pedestals, etc. which are designated with a "MEDICAL EQUIPMENT #" in the MEDICAL GAS OUTLETS schedule.
  2. The Bulk O2 storage and reserve tanks, controls, and alarms will be furnished by the bulk gas supplier (Praxair).
- D. Owner will furnish medical gases for Phase II testing specified in this Section.
- E. Related Sections include the following:
1. Division 23 Section "Meters and Gages" for thermometers, pressure gages, and fittings.



2. Division 22 Section "Medical Air and Medivac Equipment" for medical and dental air equipment and accessories.
3. Division 22 Section "Medical Vacuum Equipment" for medical and dental vacuum equipment and accessories.

### 1.3 SEISMIC REQUIREMENTS

- A. Component Importance Factor: All plumbing components shall be assigned a component importance factor. The component importance factor,  $I_p$ , shall be taken as 1.5 if any of the following conditions apply:
  1. The component is required to function for life-safety purposes after an earthquake.
  2. The component contains hazardous materials.
  3. The component is in or attached to an Occupancy Category IV structure and it is needed for continued operation of the facility or its failure could impair the continued operation of the facility.
- B. All other components shall be assigned a component importance factor,  $I_p$ , equal to 1.0.
- C. Seismic Performance: Plumbing equipment, hangers and supports shall withstand the effects of earthquake motions determined according to SEI/ASCE 7 and with the requirements specified in Section 220548 "Vibration and Seismic Controls for Plumbing Piping and Equipment."
  1. For components with a seismic importance factor of 1.0 the term "withstand" means "the system will remain in place without separation of any parts when subjected to the seismic forces specified."
  2. For components with a seismic importance factor of 1.5 the term "withstand" means "the system will remain in place without separation of any parts when subjected to the seismic forces specified and the system will be fully operational after the seismic event."

### 1.4 DEFINITIONS

- A. PTFE: Polytetrafluoroethylene.
- B. TFE: Tetrafluoroethylene.

### 1.5 SUBMITTALS

- A. Product Data: For the following:
  1. Medical gas tubes & fittings
  2. Medical gas valves & valve boxes.
  3. Medical gas specialties.
  4. Medical gas manifolds.
  5. Medical gas service connection & pressure control panels
  6. Medical gas service units. Include integral service connections.
  7. Medical gas alarm system components.
  8. Cylinder wall racks and storage racks.

- B. Wiring diagrams for medical gas alarm systems and tanks. Differentiate between manufacturer-installed and field-installed wiring.
- C. Coordination Drawings: For medical gas systems, including relationship to other services that serve same work areas.
- D. Brazing Certificates: As required by ASME Boiler and Pressure Vessel Code, Section 1X, or AWS B2.2
- E. Product Certificates: Signed by manufacturer certifying that copper tubing complies with NFPA 99, Paragraph 4-3.1.2.7, "Piping Materials."
- F. Certificates of Shop Inspection and Data Report: As required by ASME Boiler and Pressure Vessel Code.
- G. Inspection and test reports specified in "Field Quality Control" Article in Part 3 of this Section.
- H. Certificates of inspections and tests from an independent testing agency specified in "Field Quality Control" Article in Part 3 of this Section.
- I. Operation & Maintenance Data: For specialties to include in the maintenance manuals specified in Division 1.
- J. Delegated-Design Submittal:
  - 1. Design calculations and detailed fabrication and assembly of pipe anchors and alignment guides, hangers and supports for multiple pipes, expansion joints and loops, and attachments of the same to the building structure.
  - 2. Locations of pipe anchors and alignment guides and expansion joints and loops.
  - 3. Locations of and details for penetrations, including sleeves and sleeve seals for exterior walls, floors, basement, and foundation walls.
  - 4. Seismic calculations and detailed analysis: Indicate fabrication and arrangement. Detail attachments of restraints to the restrained items and to the structure. Show attachment locations, methods, and spacings. Identify components, list their strengths, and indicate directions and values of forces transmitted to the structure during seismic events. Indicate association with vibration isolation devices. Project specific design documentation and calculations shall be prepared and stamped by a registered professional engineer who is responsible for the seismic restraint design and who is licensed in the state where the project is being constructed (ASCE 7, 13.2.1.1).

#### 1.6 QUALITY ASSURANCE

- A. Testing Agency Services: This Division will provide an independent testing agency to inspect, test, and certify medical gas piping and components, except for inspections and tests specified in "Field Quality Control" Article in Part 3 of this Section.
- B. Testing Agency Qualifications: Demonstrate to Architect's satisfaction, based on Architect's evaluation of criteria conforming to ASTM E 699 that the independent testing agency has the experience and capability to satisfactorily conduct the testing indicated without delaying the Work.

- C. Listing and Labeling: Provide electrically operated specialties specified in this Section that are listed and labeled.
  - 1. Terms "Listed" and "Labeled": As defined in National Electrical Code, Article 100.
  - 2. Listing and Labeling Agency Qualifications: A "Nationally Recognized Testing Laboratory" as defined in OSHA Regulation 1910.7.
- D. Comply with NFPA 50, "Standard for Bulk Oxygen Systems at Consumer Sites."
- E. Comply with NFPA 70, "National Electrical Code."
- F. Comply with NFPA 99, "Health Care Facilities."
- G. Comply with UL 498, "Attachment Plugs and Receptacles."
- H. Comply with UL 544, "Medical and Dental Equipment."

## 1.7 DELIVERY, STORAGE, AND HANDLING

- A. Deliver and store large medical gas specialties on factory-installed shipping skids, small specialties in factory-fabricated fiberboard containers, and piping with sealing plugs in ends or with other end protection.
  - 1. Store pre-cleaned and sealed medical gas pipe, fittings, valves, and specialties with sealing plugs and sealing packaging intact.
  - 2. Label medical gas pipe, fittings, valves, and specialties that have not been pre-cleaned, or that have been pre-cleaned but have seal or packaging that is not intact, with temporary labels indicating that cleaning is required before installation.

## PART 2 - PRODUCTS

### 2.1 MANUFACTURERS

- A. Manufacturers: Subject to compliance with requirements, provide products by one of the following:
  - 1. Medical Gas Piping Specialties:
    - a. Pattons Medical
    - b. Powerex
    - c. Amico by MTA
    - d. Beacon Madaes
    - e. Tri-Tech Medical
  - 2. Medical Gas Alarm Systems:
    - a. Pattons Medical
    - b. Powerex

- c. Amico by MTA
- d. Beacon Madaes
- e. Tri-Tech Medical

3. Medical Gas Storage Tanks (Bulk Oxygen Tanks):

- a. Praxair

2.2 PIPE AND TUBES

- A. Pre-cleaned, Hard Copper Tube: ASTM B 819, Type K or Type L, seamless, drawn temper, factory cleaned, purged, and sealed for medical gas service. Include marking or labeling "CLEANED FOR MEDICAL GAS SERVICE," "CLEAN FOR OXYGEN SERVICE," "NITROGENIZED."
- B. Soft Copper Tube: ASTM B 88, Type K water tube, seamless, annealed temper. Tube may be factory cleaned, purged, and sealed for medical gas service according to ASTM B 819 or field cleaned, purged, and sealed as specified in "Preparation" Article in Part 3. Include marking or labeling "CLEANED FOR MEDICAL GAS SERVICE," "CLEAN FOR OXYGEN SERVICE," "NITROGENIZED."

2.3 PIPE AND TUBE FITTINGS

- A. Wrought-Copper Fittings: ASME B16.22, solder-joint, pressure type. Fittings may be factory cleaned, purged, and sealed for medical gas service according to ASTM B 819 or field cleaned, purged, and sealed as specified in "Preparation" Article in Part 3. Include marking or labeling "CLEANED FOR MEDICAL GAS SERVICE," "CLEAN FOR OXYGEN SERVICE," "NITROGENIZED."
- B. Bronze-Tube Flanges: ASME B16.24, Class 300.
- C. Flexible Connectors: Bronze or stainless-steel flexible pipe connectors as specified in Division 22 Section "Vibration Control."

2.4 JOINING MATERIALS

- A. Refer to Division 23 Section "Basic Mechanical Materials and Methods" for joining materials not in this Section.
- B. Brazing Filler Metals: AWS A5.8, BCuP (copper-phosphorus) series alloys. Flux is prohibited, except when used with bronze fittings.
- C. Threaded-Joint Tape: PTFE plastic.
- D. Gasket Material: ASME B16.21, nonmetallic, flat, asbestos free, and suitable for oxygen use.

2.5 VALVES AND VALVE BOXES

- A. Ball Valves, 3-Inch NPS and Smaller: MSS SP-110, bronze-body, full-port valve rated for 300-psig working pressure, with chrome-plated brass ball, PTFE or TFE seals, blowout-proof stem, threaded or braze-joint ends. Provide locking type for valves not located in valve box and handle designed for quarter turn between open and closed positions.
  - 1. Include union-type body with bolted swing-away center section.
  - 2. Include factory-cleaned, factory-sealed for oxygen use, and factory-installed, ASTM B 88, Type K or L, copper-tube extensions with pressure gage installed downstream from valve in pressure systems and upstream from valve in vacuum systems.
- B. Ball Valves, 4-Inch NPS and Larger: MSS SP-72, bronze- or iron-alloy body, full-port valve rated for 300-psig working pressure, with chrome-plated brass ball valve, PTFE or TFE seals, blowout-proof stem, flanged ends, and provide locking type for valves not located in a valve box, and handle designed for quarter turn between open and closed positions.
- C. Check Valves, 3-Inch NPS and Smaller: Bronze-body, straight-through pattern, spring-loaded ball check valve, designed for 300-psig minimum working pressure.
- D. Check Valves, 4-Inch NPS and Larger: MSS SP-71, Class 250, iron-body, bronze-trim, swing check valve, with flanged ends.
- E. Safety Valves: Bronze body with settings to match system requirements.
  - 1. Pressure Safety Valves: ASME construction.
  - 2. Vacuum Relief Valves: Equipment manufacturer's option.
- F. Pressure Regulators: Brass or bronze body and trim; spring-loaded, diaphragm-operated, relieving type; manual pressure-setting adjustment; rated for 250-psig minimum inlet pressure; and capable of controlling delivered air pressure within 0.5 psig for each 10-psig inlet pressure.
- G. Automatic Drain Valves: Corrosion-resistant metal body and internal parts, 200-psig minimum working-pressure rating, capable of automatic discharge of collected condensate.
- H. Zone Valve Boxes: Minimum 0.048-inch- thick steel, valve boxes for recessed mounting, with holes for medical gas piping and anchors. Include for single- or multiple-valve (with pressure gage) installation and in sizes to permit manual operation of valves.
  - 1. Interior Finish: Factory-applied white enamel.
  - 2. Cover Plate: Minimum 0.08-inch- thick aluminum or extruded-anodized aluminum with frangible or removable windows.
  - 3. Valve-Box Windows: Clear or tinted transparent plastic with labeling, including space for rooms served, according to NFPA 99.

## 2.6 MEDICAL GAS PIPING SPECIALTIES

- A. General: Provide the following medical gas piping specialties by same manufacturer:
- B. Emergency Oxygen Connection: Low-pressure gaseous-oxygen inlet assembly, consisting of weatherproof enclosure with hinged locking cover, suitable for recessed mounting, with factory-installed 1- or 1-1/4-inch NPS plugged inlet, pressure gage, and minimum 1-inch NPS ball valve, for connection to oxygen system. Include brass-body safety valve, set at 75 or 80 psig, which may be installed in enclosure or be separate for installation in oxygen piping system. Label enclosure cover "Emergency Low-Pressure Gaseous Oxygen Inlet." Comply with NFPA 99.
- C. Medical Gas Manifolds: Comply with NFPA 99, Chapter 4, "Cylinder Systems without Reserve Supply," with the following features:
1. Central Control Panel Unit: Weatherproof cabinet, supply and delivery pressure gages, electrical alarm system connections and transformer, indicator lights or devices, manifold connection, pressure changeover switch, line-pressure regulator, shutoff valves, and safety valve.
  2. Manifold and Headers: Duplex, nonferrous metal header for number of cylinders indicated on plans, divided into 2 equal banks or as noted two equal banks \_\_ x \_\_. Units include design for 2000-psig minimum inlet pressure, except nitrous-oxide manifolds may be designed for 800 psig and carbon-dioxide manifolds may be designed for 1500 psig. Include cylinder bank headers with flexible braided stainless steel inlet (pigtail) connections complying with CGA V-1, individual inlet check valves, shutoff valve, pressure regulator, check valve, and pressure gage.
  3. Operation: Automatic, pressure-switch-activated changeover from one cylinder bank to other cylinder bank when first bank becomes exhausted, without line-pressure fluctuation or resetting of regulators, and without supply interruption by shutoff of either cylinder bank header.
  4. Mounting: Wall mounting, complete with mounting brackets for manifold control cabinet and headers.
  5. Mounting: Floor mounting, complete with support legs for manifold control cabinet.
  6. Label manifold control unit with permanent label identifying medical gas type and system operating pressure.
  7. Nitrous-Oxide Manifolds: 2000 cu. ft./h at 55-psig line pressure with electric heater or orifice design that will prevent freezing during high demand.
  8. Nitrogen Manifolds: 3000 cu. ft./h at 180-psig line pressure.
  9. Carbon-Dioxide Manifolds: 500 cu. ft./h at 55-psig line pressure.
  10. High-Pressure Air Manifolds: 3000 cu. ft./h at 180-psig line pressure.
- D. Service Outlets (wall type): Gas specific for services listed with roughing-in and finishing assemblies. Include the following:
1. Roughing-in Assembly: Include the following:
    - a. Steel outlet box or mounting plate.
    - b. Brass-body outlet block with secondary check valve that will prevent gas flow when primary valve is removed.
    - c. Double seals that will prevent gas leakage.
    - d. ASTM B 88, Type K, 3/8-inch NPS copper inlet or outlet tube brazed to valve with gas-service marking and tube-end dust cap.

2. Finishing Assembly: Include the following:
  - a. Brass housing with primary check valve.
  - b. Double seals that will prevent gas leakage.
  - c. Cover plate with gas-service label.
3. Quick-Connect Coupling: Indexing to prevent interchange between services, constructed to permit one-handed connection and removal of equipment, and with positive-locking that retains equipment stem in valve during use. Outlets to be a type that accepts Chemetron adaptors.
4. DISS-Type Coupling: CGA V-5, DISS-threaded indexing to prevent interchange between services; constructed to permit one-handed connection and removal of equipment.
  - a. Oxygen Outlets: CGA V-5, DISS No. 1240.
  - b. Medical Air Outlets: CGA V-5, DISS No. 1160.
  - c. Medical Vacuum Inlets: CGA V-5, DISS No. 1220.
  - d. Nitrous-Oxide Outlets: CGA V-5, DISS No. 1040.
  - e. Nitrogen Outlets: CGA V-5, DISS No. 1120.
  - f. Evacuation Inlets: CGA V-5, DISS No. 2220.
  - g. Carbon-Dioxide Outlets: CGA V-5, DISS No. 1080.
  - h. High-Pressure Air Outlets: CGA V-5, DISS No. 1160.
5. Wall Outlet Cover Plates: One-piece metal, with chrome-plated finish and permanent, color-coded, medical gas identifying label matching corresponding outlets.
6. Vacuum Bottle-Slide Brackets: Bottle-slide and mounting assembly matching pattern of vacuum outlet. Include one slide bracket for each wall-mounted vacuum inlet, except where no slide bracket requirement is indicated or for ceiling outlets.
- E. Outlet Cover Plates: One-piece stainless steel, with NAAMM AMP 503, No. 4 finish and permanent identifying label.
- F. Outlet Cover Plates: One-piece metal, with chrome-plated finish and permanent identifying label.
- G. Outlet Cover Plates: One-piece anodized aluminum, with permanent identifying label.
- H. Service Hose Assemblies (ceiling type): Color coded, conductive, neoprene, 1/4- or 5/16-inch ID, lengths as required for finished ceiling height, and with indexed or DISS-type end-connection fittings suitable for medical gas service indicated.
  1. All gases except Nitrogen, Hose Assemblies: length as required for height of ceiling with 18" of pull down loop, with quick-connect fittings, valve on one end and DISS connection at the ceiling.
  2. Nitrogen Hose Assemblies: length as required for height of ceiling, with nitrogen CGA V-5, DISS No. 1120 fittings, nut on ceiling end and female Schrader outlet on other end.

3. All gases: provide single or double key chain retractor as required for retraction of pull down loop.
- I. Pressure Control Panels: Steel box and steel support brackets for recessed roughing-in. Include stainless-steel or anodized-aluminum cover plate with printed operating instructions. Include control panels with manifold assembly consisting of inlet supply valve, inlet supply pressure gage, line-pressure control regulator, outlet supply pressure gage, DISS service outlet, and piping outlet for remote service outlet.
  1. Minimum Working Pressure: 180 psig.
  2. Line-Pressure Control Regulator: Self-relieving, diaphragm type, and with precision manual adjustment.
  3. Pressure Gages: 0- to 300-psig range.
  4. Provide temporary dust shield and U-tube for testing for use before final assembly.
  5. Nitrogen Control Panels: Label cover plate "Nitrogen Pressure Control." Include CGA V-5, DISS No. 1120 nitrogen service outlet or Schrader female outlet as required by owners.
  6. Air Control Panels: Label cover plate "Air Pressure Control." Include CGA V-5, DISS No. 1160 air service outlet or Schrader female outlet as required by owners.

## 2.7 MEDICAL GAS ALARM SYSTEMS

- A. Description: Compatible alarm panels, remote sensing devices, and other related components where indicated and where required by NFPA 99. Power wiring is specified in Division 16 Sections. Panel wiring is by Division 15, Automatic Temperature Controls.
- B. Components: Designed for continuous service and to operate on power supplied from 120-V, ac power source to alarm panels and with connections for 24- or 12-V, ac low-voltage wiring to remote sensing devices. Include step-down transformers if required.
- C. Dew-Point Monitors: Continuous line monitoring, having panel with gage or digital display, pipeline sensing element, electrical connections for alarm system, factory- or field-installed valved bypass, and visual and cancelable audio signal for dryer site and master alarm panels. Operate alarm when pressure dew point rises above 39 deg F at 55 psig.
  1. Operation: Chilled-mirror method.
  2. Operation: Hygrometer moisture analyzer with sensor probe.
- D. Pressure and Vacuum Switches or Pressure Transducer Sensors: Continuous line monitoring with electrical connections for alarm system.
  1. Low-Pressure Switches: 0- to 100-psig operating range.
  2. High-Pressure Switches: Up to 250-psig operating range.
  3. Vacuum Switches: 0- to 30-in. Hg range.
- E. Carbon-Monoxide Monitors: Panel with gage or digital display, pipeline sensing element, electrical connections for alarm system, and factory- or field-installed valved bypass. Operate alarm when carbon-monoxide level rises above 10 ppm.



- F. Alarm Panels: Factory wired with audible and color-coded visible signals to indicate specified functions.
1. Mounting: Recessed installation.
  2. Enclosures: Fabricated from minimum 0.047-inch- thick steel or minimum 0.05-inch- thick aluminum, and with knockouts for electrical and piping connections.
- G. Special Features: In addition to manufacturer's standard features, include the following:
1. Master Alarm Panels: Provide (2) master alarm panels at two separate locations as indicated, each with dedicated wiring from source sensors as per NFPA 99. Each with separate trouble alarm signals, pressure (vacuum) gages, and indicators for oxygen, medical air, medical vacuum, nitrous oxide, nitrogen, evacuation, carbon dioxide, high-pressure air, laboratory air, and laboratory vacuum. Include signal alarms at master alarm panels to meet applicable codes and when the following conditions exist:
    - a. Oxygen: Main liquid level is low, pressure downstream from main shutoff valve drops below 40 psig or rises above 60 psig, reserve is in use, reserve level is low, and reserve pressure is low.
    - b. Medical Air: Pressure drops below 40 psig or rises above 60 psig, dew point rises above 39 deg F at 55 psig, carbon-monoxide level rises above 10 ppm, and fault from air compressor local alarm.
    - c. Medical Vacuum: Vacuum drops below 12 in. Hg and back-up vacuum pump is in operation (fault from local alarm).
    - d. Nitrous Oxide: Pressure drops below 40 psig or rises above 60 psig, and changeover is made to alternate bank.
    - e. Nitrogen: Pressure drops below 160 psig or rises above 200 psig, and changeover is made to alternate bank.
    - f. Evacuation: Vacuum drops below 12 in. Hg.
    - g. Carbon Dioxide: Pressure drops below 40 psig or rises above 60 psig, and changeover is made to alternate bank.
  2. Area Alarm Panels: Separate trouble alarm signals; pressure and vacuum gages; and indicators for gases served - oxygen, medical air, and medical vacuum.
  3. Anesthetizing-Area Alarm Panels: Separate trouble alarm signals; pressure and vacuum gages; and indicators for oxygen, medical air, medical vacuum, nitrous oxide, nitrogen, evacuation, carbon dioxide, and high-pressure air.
  4. Signal alarms at area alarm panels and at anesthetizing-area alarm panels when the following conditions exist:
    - a. Oxygen: Pressure drops below 40 psig or rises above 60 psig.
    - b. Medical Air: Pressure drops below 40 psig or rises above 60 psig.
    - c. Medical Vacuum: Vacuum drops below 12 in. Hg.
    - d. Nitrous Oxide: Pressure drops below 40 psig or rises above 60 psig.
    - e. Nitrogen: Pressure drops below 160 psig or rises above 200 psig.
    - f. Evacuation: Vacuum drops below 12 in. Hg.
    - g. Carbon Dioxide: Pressure drops below 40 psig or rises above 60 psig.
    - h. High-Pressure Air: Pressure drops below 160 psig or rises above 200 psig.

## 2.8 CYLINDER WALL AND STORAGE RACKS

- A. Medical Gas Cylinder Wall Racks: provide manufactured wall racks.

## 2.9 IDENTIFICATION

- A. Refer to Division 23 Section "Mechanical Identification" for piping, valves, gages, alarms, accessories, and labels for bulk storage tanks.

## PART 3 - EXECUTION

### 3.1 PREPARATION

- A. General: Where factory-precleaned and -capped piping is not available, or when precleaned piping must be recleaned because of exposure, perform the following procedures:
  1. Clean medical gas pipe and pipe fittings, valves, gages, and other components of oil, grease, and other readily oxidizable materials as required for oxygen service, according to CGA G-4.1, "Cleaning Equipment for Oxygen Service."
  2. Wash medical gas piping and components in hot, alkaline cleaner-water solution of sodium carbonate or trisodium phosphate in proportion of 1 lb of chemical to 3 gal. of water.
    - a. Scrub to ensure complete cleaning.
    - b. Rinse with clean, hot water after washing to remove cleaning solution.

### 3.2 CONCRETE BASES

- A. Construct concrete bases of dimensions indicated, but not less than 6 inches larger in both directions than supported unit and not less than 4 inches high.
- B. Refer to Division 3 Section "Cast-in-Place Concrete" for reinforcement, framing, and concrete materials for 4000-psi, 28-day compressive strength.

### 3.3 PIPING APPLICATIONS

- A. General: Refer to Part 2 of this Section for the following materials:
  1. Interior and Medical Gas Piping: Use precleaned, hard copper tube with wrought-copper fittings and brazed joints.
  2. Exterior, Buried Medical Gas Piping: Use soft copper tube with wrought-copper fittings and brazed joints.
  3. Underground, Protective Conduit: Use Schedule 80 PVC plastic pipe, Schedule 80 PVC plastic threaded pipe fittings, and threaded joints; or Schedule 80 PVC plastic socket-type pipe fittings, and solvent cement joints.

### 3.4 SERVICE ENTRANCES

- A. Extend piping and connect to bulk storage tanks and exterior manifolds, of sizes and in locations indicated for service entrances to building.
- B. Install sleeve and mechanical sleeve seal at penetrations through foundation wall for watertight installation.

### 3.5 PIPING INSTALLATION, GENERAL

- A. Refer to Division 23 Section "Basic Mechanical Materials and Methods" for basic piping installation.
- B. Install supports and anchors according to Division 23 Section "Hangers and Supports."
  - 1. Spacing between Hangers: As described in NFPA 99 and NFPA 99C.
- C. Comply with SEI/ASCE 7 and with requirements for seismic-restraint devices in Section 220548 "Vibration and Seismic Controls for Plumbing Piping and Equipment."
- D. Install emergency oxygen connection assembly with pressure relief valve and full-size discharge piping to outside, with check valve downstream from pressure relief valve, and with ball valve and check valve in supply main from bulk oxygen storage tank.
- E. Valve Applications: Use ball valves specified in this Section for main shutoff and zone valve duties.
- F. Install zone valves in valve box anchored to structure. Install valves at angle that prevents closure of cover when valve is in closed position. Single boxes may be used for multiple valves that serve same area or function.
- G. Install thermometers and pressure gages according to Division 15 Section "Meters and Gages."
- H. Install exterior, buried medical gas piping in protective conduit fabricated with PVC pipe and fittings. Do not extend conduit through foundation wall. Provide sand bedding 6" all around and metallic warming tape 18" above pipe. Bury pipe at 36" depth.
- I. Purging: Purge medical gas piping using oil-free, dry nitrogen during brazing and after installing piping but before connecting to service-outlet valves, alarms, and gages.

### 3.6 JOINT CONSTRUCTION

- A. Refer to Division 23 Section "Basic Mechanical Materials and Methods" for basic piping joint construction.

### 3.7 SPECIALTIES INSTALLATION

- A. Install specialties according to NFPA 99 and manufacturer's written instructions.

- B. Install manifolds firmly anchored to substrate and with seismic controls as indicated.
- C. Connect to ceiling-mounting service units firmly anchored to substrate according to manufacturer's written instructions.

### 3.8 MEDICAL GAS ALARM SYSTEM INSTALLATION

- A. General: Install alarm system components according to NFPA 99 and manufacturer's written instructions.
- B. Install alarm panels in locations indicated.

### 3.9 CONNECTIONS

- A. Install piping next to equipment to allow service and maintenance.
- B. Connect medical gas piping to bulk storage tanks with unions. Install with ball valves and strainers where required.
- C. Connect medical gas piping to equipment, gas manifolds, and accessories with unions. Install with ball valves and strainers.
  - 1. Install flexible pipe connectors on air piping connections to air compressors, vacuum piping connections to vacuum units, and where indicated.
  - 2. Install thermometers on air-compressor discharge piping, air receiver tanks, vacuum receiver tanks, and where indicated.
  - 3. Install pressure gages on air-compressor discharge piping, air receiver tanks, vacuum receiver tanks, and where indicated.
  - 4. Install pressure regulators downstream from air compressors, dryers, purification units, and filter assemblies.
- D. Install medical gas piping and electrical connections to medical gas alarm system components.
- E. Arrange for electric-power connections to specialties and devices that require power. Electric power, wiring, and disconnect switches are specified in Division 26 Sections.

### 3.10 LABELING AND IDENTIFICATION

- A. Install labeling on valves, valve-box covers, and alarm panels according to requirements of NFPA 99.
- B. Refer to Division 23 Section "Mechanical Identification" for labeling and identification materials.
- C. Captions and Color Coding: Use the following or similar medical gas captions and color coding for specialties, when specified and where required by NFPA 99:

1. Oxygen: White letters on green background.
  2. Medical Air: Black or white letters on yellow background.
  3. Medical Vacuum: Black letters on white background.
  4. Nitrous Oxide: White letters on blue background.
  5. Nitrogen: White letters on black background.
  6. Evacuation: Black letters on white background or white letters on purple background.
  7. Carbon Dioxide: White letters on gray background.
- D. Label medical gas systems operating at other than standard pressure with system operating pressure.
- E. Install continuous metallic underground warning tape during backfilling of trench for underground medical gas piping.
- F. Refer to Division 2 Section "Earthwork" for warning tapes.

### 3.11 FIELD QUALITY CONTROL

- A. Pressure Test: Subject each piping section of each system, except high-pressure air and nitrogen, to test pressure of from 150 to 200 psig and high-pressure air and nitrogen systems to test pressure of 250 psig with oil-free, dry nitrogen before attaching system components, after installing station outlets with test caps (when supplied) in place, and before concealing piping system. Maintain test until joints are examined for leaks by means of soapy water.
- B. Standing-Pressure Test: Install assembled system components after testing individual systems as specified above. Subject systems to 24-hour standing-pressure test at 20 percent above normal line pressure, but not less than 66 psig. Subject vacuum and evacuation systems to 12- to 18-in. Hg minimum vacuum instead of pressure test.
- C. Repair leaks, replace damaged components with new materials, and retest system until satisfactory results are obtained.
- D. Inspect, test, and certify complete medical gas systems according to requirements of NFPA 99, "Health Care Facilities." Inspect, test, and certify each medical gas system, including each piping system, outlets and inlets, accessories, alarm panels and devices, safety devices, medical gas sources, and equipment.
- E. Provide oil-free, dry nitrogen; materials; equipment; and labor required for testing.
- F. Provide medical gases required for testing systems.
- G. Prepare written reports of tests results, including corrective action.
- H. Certify that medical gas systems comply with requirements specified, that tests were properly performed, and that test results were satisfactory.
- I. Inspect outlets and inlets, gages, alarms, and zone valves for proper labeling for gas service and function.

- J. Inspect manifold supply systems for installation and operation as required by NFPA 99, Chapter 4, "Gas and Vacuum Systems."
- K. Inspect bulk oxygen supply systems for installation and operation as required by NFPA 50.
- L. Inspect bulk nitrous-oxide supply systems for installation and operation as required by CGA G-8.1.
- M. Phase I Tests: Perform the following tests using oil-free, dry nitrogen after installing gas systems but before connecting new systems to existing gas sources:
  - 1. Outlet and Inlet Cross-Connection Test: Pressurize one medical gas system to 50 psig, with other systems at atmospheric pressure, and access each outlet with appropriate adapter and test gage. Repeat procedure for each system.
  - 2. Outlet and Inlet Cross-Connection Test: Pressurize each system in 10-psig increments and access each outlet with appropriate adapter and test gage.
  - 3. Alarm System Test: Test for operation of functions specified in "Medical Gas Alarm Systems" Article within limits required.
  - 4. Pressure Test: Test systems at operational pressure with system components installed. No leaks are allowed. Conduct tests by zone.
  - 5. Particulate Sampling: Test positive-pressure terminal outlets, using 0.45-micron filter, for evidence of solid particulate contamination. Allowable limit is 2 mg/cu. m.
  - 6. Moisture: Test positive-pressure terminal outlets for dew point to verify absence of moisture in piping. Dew point of gas dispensed from terminal outlets shall not exceed dew point of source test gas by more than 4 deg F.
  - 7. System Purity: Test terminal outlets and gas source for contaminant levels as defined below. Excessive contaminant levels will require additional purging to outlets within specific zone until levels are within the following limits:
    - a. Total Hydrocarbons as Methane: One ppm.
    - b. Halogenated Hydrocarbons: 2 ppm.
    - c. Carbon Monoxide: 2 ppm.
  - 8. Air-Compressor Purity: Collect medical air-compressor air samples taken from downstream side of filters and air dryers. Test samples for contaminants and moisture within the following limits:
    - a. Total Hydrocarbons as Methane: 25 ppm.
    - b. Halogenated Hydrocarbons: 5 ppm.
    - c. Carbon Monoxide: 10 ppm.
    - d. Moisture, Dew Point: Plus 40 deg F at dryer discharge.
- N. Phase II Tests: After Phase I testing has been completed, test completed medical gas systems using applicable medical gas for each system. Completed systems have outlets and inlets, alarms, and gages installed; and gas supply systems are installed and ready for operation.
  - 1. Final Purging: Introduce applicable medical gas for each system into respective piping systems. Purge installed outlet valves to remove nitrogen test gas present from Phase I testing. Test vacuum inlets for ability to flow.

2. Outflow Analysis: Analyze medical gas at positive-pressure outlets to confirm delivery of proper medical gas at proper concentration level. Minimum allowable concentration levels are defined by U.S. Pharmacopeia's USP-NF and the following CGA Commodity Specifications:
    - a. CGA G-4.3, "Commodity Specification for Oxygen."
    - b. CGA G-6.2, "Commodity Specification for Carbon Dioxide."
    - c. CGA G-7.1, "Commodity Specification for Air."
    - d. CGA G-8.2, "Commodity Specification for Nitrous Oxide."
    - e. CGA G-10.1, "Commodity Specification for Nitrogen."
  3. System Delivery Pressures: Test pressure piping systems to confirm supply sources are set to deliver gas at the following nominal pressure levels:
    - a. All Systems, except Nitrogen and High-Pressure Air: 50 to 55 psig at maximum flow.
    - b. Nitrogen and High-Pressure Air: 180 psig minimum at maximum flow.
  4. System Suction Levels: Test vacuum and evacuation piping systems to confirm that vacuum producers are set to maintain suction of not less than 12 in. Hg at most distant inlets.
- O. Testing Agency Certification: Certify that specified inspection, tests, and procedures have been performed and report results. Include the following:
1. Inspections performed.
  2. Procedures, materials, and gases used.
  3. Test methods used.
  4. Results of tests.

### 3.12 COMMISSIONING

- A. Startup Services: Engage a factory-authorized service representative to inspect alarm system installation and to provide startup service.
1. Test and adjust controls and safeties. Replace damaged and malfunctioning controls and equipment discovered by service representative.
- B. Perform the following final checks before startup:
1. Verify that specified tests of piping are complete.
  2. Check safety valves for correct settings. Ensure settings are greater than air-compressor discharge pressure, but not greater than rating of system components.

### 3.13 DEMONSTRATION

- A. Startup Services: Engage a factory-authorized service representative to demonstrate procedures for alarm system startup and shutdown, preventive maintenance and servicing, and troubleshooting. Review operating and maintenance information.

- B. Provide written notice 7 days in advance of demonstration.

END OF SECTION



**SECTION 23 01 00 - MECHANICAL REQUIREMENTS**

## PART 1 - GENERAL

## 1.1 GENERAL CONDITIONS

- A. The General Conditions of the Contract, with the amendments, supplements, forms and requirements in Division 1, and herewith made a part of this Division.
- B. All sections of Division 21, 22, & 23 shall comply with the Mechanical General Requirements. The standards established in this section as to quality of materials and equipment, the type and quality of workmanship, mode of operations, safety rules, code requirements, etc., shall apply to all sections of this Division as though they were repeated in each Division.
- C. Mechanical equipment that is pre-purchased if any will be assigned to the Mechanical Contractor. By assignment to the Mechanical Contractor, the Mechanical Contractor shall accept and installed the equipment and provide all warranties and guarantees as if the Mechanical Contractor had purchased the equipment.
- D. Construction Indoor-Air Quality Management
  - 1. Comply with SMACNA's "SMACNA IAQ Guideline for Occupied Buildings under Construction."
    - a. If Owner authorizes use of permanent heating, cooling, and ventilating systems during construction period as specified in Division 01 Section "Temporary Facilities and Controls," install filter media having a MERV 8 according to ASHRAE 52.2 at each return-air inlet for the air-handling system used during construction.
    - b. Replace all air filters immediately prior to occupancy.

## 1.2 SCOPE OF WORK

- A. The project described herein is the Intermountain McKay-Dee Hospital Pulmonary Clinic Remodel. This work shall include all labor, materials, equipment, fixtures, and devices for the entire mechanical work and a complete operating and tested installation as required for this project.
- B. This Division will schedule the boiler inspection and pay for all costs associated with certifying the boiler with the state.

## 1.3 CODES &amp; ORDINANCES

- A. All work shall be executed in accordance with all underwriters, public utilities, local and state rules and regulations applicable to the trade affected. Should any change in the plans and Specifications be required to comply with these regulations, the Contractor shall notify the Architect before the time of submitting his bid. After entering into contract, the Contractor will be held to complete all work necessary to meet these requirements without extra expense to the Owner. Where work required by drawings or specifications is above the standard required, it shall be done as shown or specified.

- B. Applicable codes:
1. Utah Boiler and Pressure Vessel Rules and Regulations-2019 Edition
  2. International Building code- 2021 Edition
  3. International Mechanical Code- 2021 Edition
  4. International Plumbing Code- 2021 Edition
  5. International Fire Code- 2021 Edition
  6. International Energy Code- 2021 Edition
  7. International Fuel Gas Code- 2021 Edition
  8. National Electrical Code- 2017 Edition

#### 1.4 INDUSTRY STANDARDS

- A. All work shall comply with the following standards.
1. Associated Air Balance council (AABC)
  2. Air Conditioning and Refrigeration Institute (ARI)
  3. Air Diffusion council (ADC)
  4. Air Movement and Control Association (AMCA)
  5. American Gas Association (AGA)
  6. American National Standards Institute (ANSI)
  7. American Society of Heating, Refrigeration, and Air Conditioning Engineers (ASHRAE)
  8. American Society of Mechanical Engineers (ASME)
  9. American Society of Testing Materials (ASTM)
  10. American Water Works Association (AWWA)
  11. Cooling Tower Institute (CTI)
  12. ETL Testing Laboratories (ETL)
  13. Institute of Electrical and Electronic Engineers (IEEE)
  14. Hydronics Institute (HI)
  15. Manufacturers Standardization Society of the Valve and Fitting Industry (MSS)
  16. National Fire Protection Association (NFPA)
  17. National Electrical Code (NEC)
  18. National Electrical Manufacturers Association (NEMA)
  19. National Electrical Safety code (NESC)
  20. Utah safety Standard (OSHA), Utah State Industrial Council.
  21. Sheet Metal and Air Conditioning Contractor's National Association (SMACNA)
  22. Underwriters Laboratories (UL)
  23. Tubular Exchanger Manufacturers Association, Inc. (TEMA)
  24. Heat Exchanger Institute (HEI)
  25. Hydraulic Institute (HI)
  26. Thermal Insulation Manufacturer=s Association (TIMA)
  27. Scientific Apparatus Makers Association (SAMA)
- B. Compliance Verification:
1. All items required by code or specified to conform to the ASME code shall be stamped with the ASME seal.
  2. Form U-1, the manufacturer=s data report for pressure vessels, is to be included in the Operation and Maintenance Manuals. National Board Register (NBR) numbers shall be provided where required by code.
  3. Manufactured equipment which is represented by a UL classification and/or listing, shall bear the UL or equivalent ETL label.

## 1.5 UTILITIES &amp; FEES

- A. All fees for permits required by this work will be paid by this division. The contractor shall obtain the necessary permits to perform this work. Unless noted otherwise, all systems furnished and or installed by this Contractor, shall be complete with all utilities, components, commodities and accessories required for a fully functioning system. This Contractor shall furnish smoke generators when required for testing, furnish glycol for glycol piping systems, full load of salt to fill brine tank for water softening system, furnish cleaners and water treatment additives.

## 1.6 SUBMITTALS AND SHOP DRAWINGS

- A. General: As soon as possible after the contract is awarded, but in no case more than 45 calendar days thereafter, the Contractor shall submit to the Architect manufacturer's data on products and materials to be used in the installation of mechanical systems for this project. The review of the submitted data will require a minimum of 14 days. The first day starts after the day they are received in the engineer's office to which the project is being constructed from. If the Contractors schedule requires return of submitted literature in less than the allotted time, the Contractor shall accelerate his submittal delivery date. The Contractor shall resubmit all items requiring re-review within 14 days of returned submittals. Refer to each specification section for items requiring submittal review. If the re-submittal is returned a 2<sup>nd</sup> time for correction the Contractor will provide the specific equipment that is specified on the drawings and/or the specifications. Written approval of the Owner's Representative shall be obtained before installing any such equipment or materials for the project.
- B. Review by the Owner's Representative is for general conformance of the submitted equipment to the project specification. In no way does such review relieve this Contractor of his obligation to furnish equipment and materials that comply in detail to the specification nor does it relieve the Contractor of his obligation to determine actual field dimensions and conditions that may affect his work. Regardless of any items overlooked by the submittal review, the requirements of the contract drawings and specifications must be followed and are not waived or superseded in any way by the review.
- C. By description, catalog number, and manufacturer's names, standards of quality have been established by the Architect and the Engineer for certain manufactured equipment items and specialties that are to be furnished by this Division. Alternate products and equipment may be proposed for use only if specifically named in the specifications or if given written prior approval in published addenda. Design equipment is the equipment listed on the drawings or if not listed on the drawings is the equipment first named in the specifications.
- D. If the Engineer is required to do additional design work to incorporate changes caused by submitting equipment or products, different than the design equipment specified, as defined above, the contractor shall reimburse the engineer for additional time and expenses at the engineer's current, recognized, hourly rates.
- E. Submittal Format: At the contractor's discretion, project submittals may be in either of the formats described in the following paragraphs, but mixing the two formats is not acceptable.

1. **Hardcopy Submittal Format:** Six (6) copies of the descriptive literature covering products and materials to be used in the installation of mechanical systems for this project will be provided for review. The submittals shall be prepared in an orderly manner, contained in a 3-ring loose-leaf binder with index and identification tab for each item or group of items and for each specification section. All items shall be submitted at one time except automatic temperature control drawings and seismic restraint drawings which may be submitted separately within 120 days of the contract award date. Partial submittals will not be reviewed until the complete submittal is received.
  - a. Submitted literature shall bear the Contractor's stamp, indicating that he has checked all equipment being submitted; that each item will fit into the available space with the accesses shown on the drawings; and, further, that each item conforms to the capacity and quality standards given in the contract documents.
  - b. Submitted literature shall clearly indicate performance, quality, and utility requirements; shall show dimension and size of connection points; and shall include derating factors that were applied for each item of equipment to provide capacity at job site elevation. Temperature control submittals shall include piping and wiring diagrams, sequence of operation and equipment. Equipment must fit into the available space with allowance for operation, maintenance, etc. Factory piped and wired equipment shall include shop drawings for all internal wiring and piping furnished with the unit.
  - c. Submitted literature shall clearly show all required field install wiring, piping, and accessory installations required by the Contractor to provide a complete operating system.
  
2. **Electronic Submittal Format:** Identify and incorporate information in each electronic submittal file as follows:
  - a. All items shall be submitted at one time except automatic temperature control drawings and seismic restraint drawings which may be submitted separately within 120 days of the contract award date. Partial submittals will not be reviewed until the complete submittal is received.
  - b. Submitted electronic file shall bear the Contractor's stamp, indicating that he has checked all equipment being submitted; that each item will fit into the available space with the accesses shown on the drawings; and, further, that each item conforms to the capacity and quality standards given in the contract documents.
  - c. Submitted electronic file shall clearly indicate performance, quality, and utility requirements; shall show dimension and size of connection points; and shall include derating factors that were applied for each item of equipment to provide capacity at job site elevation. Temperature control submittals shall include piping and wiring diagrams, sequence of operation and equipment. Equipment must fit into the available space with allowance for operation, maintenance, etc. Factory piped and wired equipment shall include shop drawings for all internal wiring and piping furnished with the unit.
  - d. Submitted electronic file shall clearly show all required field install wiring, piping, and accessory installations required by the Contractor to provide a complete operating system.
  - e. Assemble complete submittal package into a single indexed file incorporating submittal requirements of a single Specification Section and transmittal form with links enabling navigation to each item.

- f. Name file with submittal number or other unique identifier, including revision identifier.
- g. Electronic file shall be completely electronically searchable or it will be rejected.
- h. Provide means for insertion to permanently record Contractor's review and approval markings and action taken by:
  - 1) Architect.
- i. Transmittal Form for Electronic Submittals:
  - 1) Use one of the following options acceptable to the Owner;
    - a) Software-generated form from electronic project management software.
    - b) Electronic form.
  - 2) The Electronic Submittal shall contain the following information:
    - a) Project name.
    - b) Date.
    - c) Name and address of Architect.
    - d) Name of Construction Manager.
    - e) Name of Contractor.
    - f) Name of firm or entity that prepared submittal.
    - g) Names of subcontractor, manufacturer, and supplier.
    - h) Category and type of submittal.
    - i) Submittal purpose and description.
    - j) Specification Section number and title.
    - k) Specification paragraph number or drawing designation and generic name for each of multiple items.
    - l) Drawing number and detail references, as appropriate.
    - m) Location(s) where product is to be installed, as appropriate.
    - n) Related physical samples submitted directly.
    - o) Indication of full or partial submittal.
    - p) Transmittal number[, numbered consecutively].
    - q) Submittal and transmittal distribution record.
    - r) Other necessary identification.
    - s) Remarks.
- j. Metadata: Include the following information as keywords in the electronic submittal file metadata:
  - 1) Project name.
  - 2) Number and title of appropriate Specification Section.
  - 3) Manufacturer name.
  - 4) Product name.

## 1.7 DRAWINGS AND MEASUREMENTS

- A. Construction Drawings: The contract document drawings show the general design, arrangements, and extent of the system. In certain cases, the drawings may include details that show more nearly exact locations and arrangements; however, the locations, as shown diagrammatically, are to be regarded as general.

- B. It shall be the work of this Section to make such slight alterations as may be necessary to make adjustable parts fit to fixed parts, leaving all complete and in proper shape when done. All dimensions given on the drawings shall be verified as related to this work and with the Architect's office before work is started.
- C. This Section shall carefully study building sections, space, clearances, etc., and then provide offsets in piping or ductwork as required to accommodate the building structure without additional cost to the Owner. In any case and at any time during the construction process, a change in location required by obstacles or the installation of other trades not shown on the mechanical plans shall be made without charge.
- D. The drawings shall not be scaled for roughing in measurements nor shall they be used as shop drawings. Where drawings are required for these purposes or where drawings must be made from field measurements, the Contractor shall take the necessary measurements and prepare the drawings. Shop drawings of the various subcontractors shall be coordinated to eliminate all interferences and to provide sufficient space for the installation of all equipment, piping, ductwork, etc.
- E. The drawings and specifications have been prepared to supplement each other and they shall be interpreted as an integral unit with items shown on one and not the other being furnished and installed as though shown and called out on both.
- F. Coordination Drawings: The contractor shall provide coordination drawings for mechanical rooms, fan rooms, equipment rooms, and congested areas to eliminate conflicts with equipment, piping, or work of other trades. The drawings shall be a minimum scale of 1/4 inch= 1 foot and of such detail as may be required by the Engineer to fully illustrate the work. These drawings shall include all piping, conduit, valves, equipment, and ductwork.
- G. Sheet-metal shop drawings will be required for all ductwork in the entire building. These drawings will show all ductwork in the entire building and shall be coordinated with architectural, structural and electrical portions of the project. The contractor shall specifically obtain copies of the structural shop drawings and shall coordinate the ductwork shop drawings with approved structural members. These drawings shall be submitted to the engineer for review prior to any fabrication. The contractor is responsible for all modifications necessary to accommodate duct installation within the structural, architectural and electrical restrictions. These drawings, once reviewed by the engineer, will be made available to all mechanical, electrical, and fire sprinkler subcontractors to coordinate installation of their work.

#### 1.8 CONTRACTOR'S USE OF BUILDING EQUIPMENT

- A. The Contractor may use equipment such as electric motors, fans, heat exchangers, filters, etc., with the written permission of the Owner. As each piece of equipment is used (such as electric motors and fans), maintenance procedures approved by the manufacturer are to be followed. A careful record is to be kept of the length of the time the equipment is used, maintenance procedures followed, and any difficulty encountered. The record is to be submitted to the Owner upon acceptance. All fan belts and filter media (such as bearings) shall be carefully inspected just prior to acceptance. Any excessive wear noted shall require replacement. New filter media shall be installed in air handlers at the time systems are turned over to the owner.

## 1.9 EXISTING CONDITIONS

- A. The Contractor shall carefully examine all existing conditions that might affect the mechanical system and shall compare these conditions with all drawings and specifications for work included under this contract. He shall, at such time, ascertain and check all conditions that may affect his work. No allowance shall subsequently be made in his behalf for an extra expense incurred as a result of his failure or neglect to make such examination. This Contractor shall include in his bid proposal all necessary allowances to repair or replace any item that will remain or will be removed, and any item that will be damaged or destroyed by new construction.
- B. The Contractor shall remove all abandoned piping, etc., required by new construction and cap or plug openings. No capping, etc., shall be exposed in occupied areas. All openings of items removed shall be sealed to match adjacent surfaces.
- C. The Contractor shall verify the exact location of all existing services, utilities, piping, etc., and make connections to existing systems as required or as shown on the drawings. The exact location of each utility line, together with size and elevation, shall be established before any on-site lines are installed. Should elevation or size of existing main utility lines make connections to them impossible as shown on drawings, then notification of such shall immediately be given to the Owners Representative for a decision.

## 1.10 EQUIPMENT CAPACITIES

- A. Capacities shown for equipment in the specifications and on the drawings are the minimum acceptable. No equipment shall be considered as an alternate that has capacities or performance less than that of design equipment.
- B. All equipment shall give the specified capacity and performance at the job-site elevation. Manufacturers' standard ratings shall be adjusted accordingly. All capacities and performances listed on drawings or in specifications are for job-site conditions.

## 1.11 SEISMIC REQUIREMENTS FOR EQUIPMENT

- A. All equipment shall be furnished structurally adequate to withstand seismic forces as outlined in the International Building Code. Refer to section Mechanical Vibration Controls and Seismic Restraints. Equipment bases shall be designed for direct attachment of seismic snubbers and/or seismic anchors.

## 1.12 COOPERATION WITH OTHER TRADES

- A. The Contractor shall refer to other drawings and parts of this specification that cover work of other trades that is carried on in conjunction with the mechanical work such that all work can proceed without interference resulting from lack of coordination.
- B. The Contractor shall properly size and locate all openings, chases, sleeves, equipment bases, and accesses. He shall provide accurate wiring diagrams to the Electrical Contractor for all equipment furnished under this Division.

- C. The ceiling cavity must be carefully reviewed and coordinated with all trades. In the event of conflict, the installation of the mechanical equipment and piping shall be in the following order: plumbing, waste, and soil lines; supply, return, and exhaust ductwork; water piping; medical gases; fire protection piping; and pneumatic control piping.
- D. The mechanical Contractor shall insure that the installation of all piping, ducts and equipment is in compliance with Articles 110-16 and 384-4 of the National Electrical Code relative to proper clearances in front of and over all electrical panels and equipment. No piping or ductwork will be allowed to run over electrical panel.

#### 1.13 RESPONSIBILITY OF CONTRACTOR

- A. The Contractor is responsible for the installation of a satisfactory piece of work in accordance with the true intent of the drawings and specifications. He shall provide, as a part of his work and without expense, all incidental items required even though these items are not particularly specified or indicated. The installation shall be made so that its several component parts will function together as a workable system and shall be left with all equipment properly adjusted and in working order. The Contractor shall familiarize the Owner's Representative with maintenance and lubrication instructions as prepared by the Contractor and shall explain and fully instruct him relative to operating, servicing, and maintenance of them.
- B. If a conflict arises between the drawings and the specifications the most stringent procedure/action shall be followed. A clarification to the engineer will help to determine the course of action to be taken. If a conflict arises between specification sections the engineer will determine which course of action is to be followed.

#### 1.14 PIPE AND DUCT OPENINGS AND EQUIPMENT RECESSES

- A. Pipe and duct chases, openings, and equipment recesses shall be provided by others only if shown on architectural or structural drawings. All openings for the mechanical work, except where plans and specifications indicate otherwise, shall be provided as work of this Division. Include openings information with coordination drawings.
- B. Whether chases, recesses, and openings are provided as work of this Division or by others, this Contractor shall supervise their construction and be responsible for the correct size and location even though detailed and dimensioned on the drawings. This Contractor shall pay for all necessary cutting, repairing, and finishing if any are left out or incorrectly made. All necessary openings thru existing walls, ceilings, floors, roofs, etc. shall be provided by this Contractor unless indicated otherwise by the drawing and/or specifications.

#### 1.15 UNFIT OR DAMAGED WORK

- A. Any part of this installation that fails, is unfit, or becomes damaged during construction, shall be replaced or otherwise made good. The cost of such remedy shall be the responsibility of this Division.



## 1.16 WORKMANSHIP

- A. Workmanship shall be the best quality of its kind for the respective industries, trades, crafts, and practices, and shall be acceptable in every respect to the Owner's representative. Nothing contained herein shall relieve the Contractor from making good and perfect work in all details in construction.

## 1.17 SAFETY REGULATION

- A. The Contractor shall comply with all local, Federal, and OSHA safety requirements in performance with this work. (See General Conditions). This Contractor shall be required to provide equipment, supervision, construction, procedures, and all other necessary items to assure safety to life and property.

## 1.18 ELECTRICAL SERVICES

- A. All equipment control wiring and all automatic temperature control wiring including all necessary contacts, relays, and interlocks, whether low or line voltage, except power wiring, shall be furnished and installed as work of this Division unless shown to be furnished by Division 26. All such wiring shall be in conduit as required by electrical codes. Wiring in the mechanical rooms, fans rooms and inaccessible ceilings and walls shall be installed in conduit as well. Installation of any and all wiring done under Division 21, 22 and 23 shall be in accordance with the requirements of Division 26, Electrical.
- B. All equipment that requires an electrical connection shall be furnished so that it will operate properly and deliver full capacity on the electrical service available.
- C. Refer to the electrical control equipment and wiring shown on the diagrams. Any changes or additions required by specific equipment furnished shall be the complete responsibility of the Contractor furnishing the equipment.
- D. The Mechanical Contractor must coordinate with the Electrical Contractor to insure that all required components of control work are included and fully understood. No additional cost shall accrue to the Owner as a result of lack of such coordination.

## 1.19 WORK, MATERIALS, AND QUALITY OF EQUIPMENT

- A. Unless otherwise specified, all materials shall be new and of the best quality of their respective kinds and all labor shall be done in a most thorough and workmanlike manner.
- B. Products or equipment of any of the manufacturers cited herein or any of the products approved by the Addenda may be used. However, where lists of products are cited herein, the one first listed in the design equipment used in drawings and schedules to establish size, quality, function, and capacity standards. If other than design equipment is used, it shall be carefully checked for access to equipment, electrical and control requirements, valving, and piping. Should changes or additions occur in piping, valving, electrical work, etc., or if the work of other Contractors would be revised by the alternate equipment, the cost of all changes shall be borne as work of this Division.

- C. The Execution portions of the specifications specify what products and materials may be used. Any products listed in the Product section of the specification that are not listed in the Execution portion of the specification may not be used without written approval by the Engineer.
- D. The access to equipment shown on the drawings is the minimum acceptable space requirements. No equipment that reduces or restricts accessibility to this or any other equipment will be considered.
- E. All major items of equipment are specified in the equipment schedules on the drawings or in these specifications and shall be furnished complete with all accessories normally supplied with the catalog item listed and all other accessories necessary for a complete and satisfactory installation.
- F. All welders shall be certified in accordance with Section IX of the ASME Boiler and Pressure Vessel Code, latest Edition.

#### 1.20 PROTECTION AGAINST WEATHER AND STORING OF MATERIALS

- A. All equipment and materials shall be properly stored and protected against moisture, dust, and wind. Coverings or other protection shall be used on all items that may be damaged or rusted or may have performance impaired by adverse weather or moisture conditions. Damage or defect developing before acceptance of the work shall be made good at the Contractor's expense.
- B. All open duct and pipe openings shall be adequately covered at all times.

#### 1.21 INSTALLATION CHECK

- A. An experienced, competent, and authorized representative of the manufacturer or supplier of each item of equipment indicated in the equipment schedule and the seismic supplier shall visit the site of the work and inspect, check, adjust if necessary, and approve the equipment installation. In each case, the equipment supplier's representative shall be present when the equipment is placed in operation. The equipment supplier's representative shall revisit the job site as often as necessary until all trouble is corrected and the equipment installation and operation is satisfactory to the Engineer.
- B. Each equipment supplier's representative shall furnish to the Owner, through the Engineer, a written report certifying that the equipment (1) has been properly installed and lubricated; (2) is in accurate alignment; (3) is free from any undue stress imposed by connecting piping or anchor bolts; and, (4) has been operated under full load conditions and that it operated satisfactorily.
- C. All costs for this work shall be included in the prices quoted by equipment suppliers.

#### 1.22 EQUIPMENT LUBRICATION

- A. The Contractor shall properly lubricate all pieces of equipment before turning the building over to the Owner. A linen tag shall be attached to each piece of equipment, showing

the date of lubrication and the lubricant used. No equipment shall be started until it is properly lubricated.

- B. Necessary time shall be spent with the Owner's Representative to thoroughly familiarize him with all necessary lubrications and maintenance that will be required of him.
- C. Detergent oil as used for automotive purposes shall not be used for this work.

#### 1.23 CUTTING AND PATCHING

- A. No cutting or drilling in structural members shall be done without written approval of the Architect. The work shall be carefully laid out in advance, and cutting, channeling, chasing, or drilling of floors, walls, partitions, ceilings, or other surfaces necessary for the mechanical work shall be carefully done. Any damage to building, piping, or equipment shall be repaired by professional plasterers, masons, concrete workers, etc., and all such work shall be paid for as work of this Division.
- B. When concrete, grading, etc., is disturbed, it shall be restored to original condition as described in the applicable Division of this Specification.

#### 1.24 EXCAVATION AND BACKFILLING

- A. All necessary excavations and backfilling for the Mechanical phase of this project shall be provided as work of this Division. Trenches for all underground pipelines shall be excavated to the required depths. The bottom of trenches shall be compacted hard and graded to obtain required fall. Backfill shall be placed in horizontal layers, not exceeding 12 inches in thickness, and properly moistened. Each layer shall be compacted, by suitable equipment, to a density of not less than 95 percent as determined by ASTM D-1557. After pipelines have been tested, inspected, and approved, the trench shall be backfilled with selected material. Excess earth shall be hauled from the job site. Fill materials approved by the Architect shall be provided as work of this Division.
- B. No trenches shall be cut near or under any footings without consultation first with the Architect's office. Any trenches or excavations more than 30 inches deep shall be tapered, shored, covered, or otherwise made absolutely safe so that no vehicle or persons can be injured by falling into such excavations, or in any way be harmed by cave-ins, shifting earth, rolling rocks, or by drowning. This protection shall be extended to all persons approaching excavation related to this work whether or not such persons are authorized to be in the vicinity of the construction.

#### 1.25 ACCESS

- A. Provide access doors in walls, ceilings and floors by this division unless otherwise noted. For access to mechanical equipment such as valves, dampers, VAV boxes, fans, controls, etc. Refer to Division 8 for door specifications. All access doors shall be 24" x 24" unless otherwise indicated or required. Coordinate location of doors with the Architect prior to installation. . If doors are not specified in Division 8, provide the following: Doors in ceilings and wall shall be equal to JR Smith No. 4760 bonderized and painted. Doors in tile walls shall be equal to JR Smith No. 4730 chrome plated. Doors in floors shall be equal to JR Smith No. 4910

- B. Valves: Valve must be installed in locations where access is readily available. If access is compromised, as judged by the Mechanical Engineer, these valves shall be relocated where directed at the Contractors expense.
- C. Equipment: Equipment must be installed in locations and orientations so that access to all components requiring service or maintenance will not be compromised. If access is compromised, as judged by the Mechanical Engineer, the contractor shall modify the installation as directed by the Engineer at the Contractors expense.
- D. It is the responsibility of this division to install terminal boxes, valves and all other equipment and devices so they can be accessed. If any equipment or devices are installed so they cannot be accessed on a ladder a catwalk and ladder system shall be installed above the ceiling to access and service this equipment.

#### 1.26 CONCRETE BASES AND INSERTS

- A. Bases: The concrete bases shall be provided and installed as work by this division. This Division shall be responsible for the proper size and location of bases and shall furnish all required anchor bolts and sleeves with templates to be installed as work of Division 3, Concrete.
- B. All floor-mounted mechanical equipment shall be set on 6-inch high concrete bases, unless otherwise noted or shown on drawings. Such bases shall extend 6 inches beyond equipment or mounting rails on all sides or as shown on the drawings and shall have a 1-inch beveled edge all around.
- C. Inserts: Where slotted or other types of inserts required for this work are to be cast into concrete, they shall be furnished as work of this Division
- D. Concrete inserts and pipe support systems shall be equal to Unistrut P3200 series for all piping where more than one pipe is suspended at a common location. Spacing of the inserts shall match the size and type of pipe and of ductwork being supported. The Unistrut insert and pipe support system shall include all inserts, vertical supports, horizontal support members, clamps, hangers, rollers, bolts, nuts, and any other accessory items for a complete pipe-supporting system.

#### 1.27 CLEANING AND PAINTING

- A. Cleaning: After all tests and adjustments have been made and all systems pronounced satisfactory for permanent operation, this Contractor shall clean all exposed piping, ductwork, insulated members, fixture, and equipment installed under this Section and leave them ready for painting. He shall refinish any damaged finish and leave everything in proper working order. The Contractor shall remove all stains or grease marks on walls, floors, glass, hardware, fixtures, or elsewhere, caused by his workman or for which he is responsible. He shall remove all stickers on plumbing fixtures, do all required patching up and repair all work of others damaged by this division of the work, and leave the premises in a clean and orderly condition.
- B. Painting: Painting of exposed pipe, insulated pipe, ducts, or equipment is work of Division 9, Painting.

- C. Mechanical Contractor: All equipment which is to be furnished in factory prefinished conditions by the mechanical Contractor shall be left without mark, scratch, or impairment to finish upon completion of job. Any necessary refinishing to match original shall be done. Do not paint over nameplates, serial numbers, or other identifying marks.
- D. Removal of Debris, Etc: Upon completion of this division of the work, remove all surplus material and rubbish resulting from this work, and leave the premises in a clean and orderly condition.

#### 1.28 CONTRACT COMPLETION

- A. Incomplete and Unacceptable Work: If additional site visits or design work is required by the Engineer or Architect because of the use of incomplete or unacceptable work by the Contractor, then the Contractor shall reimburse the Engineer and Architect for all additional time and expenses involved.
- B. Maintenance Instructions: The Contractor shall furnish the Owner complete printed and illustrated operating and maintenance instructions covering all units of mechanical equipment, together with parts lists.
- C. Instructions To Owner's Representatives: In addition to any detailed instructions called for, the mechanical Contractor must provide, without expense to the Owner, competent instructors to train the Owner's representatives who will be in charge of the apparatus and equipment, in the care, adjustment, and operation of all parts on the heating, air conditioning, ventilating, plumbing, fire protection, and automatic temperature control equipment. Instruction dates shall be scheduled at time of final inspection. A written report specifying times, dates, and name of personnel instructed shall be forwarded to the Architect. A minimum of four 8-hour instruction periods shall be provided. The instruction periods will be broken down to shorter periods when requested by the Owner. The total instruction hours shall not be reduced. The ATC Contractor shall provide 4 hours of instructions. The remaining hours shall be divided between the mechanical and sheet metal Contractor.
- D. Guarantee: By the acceptance of any contract award for the work herein described or shown on the drawings, the Contractor assumes the full responsibility imposed by the guarantee as set forth herein and in the General Conditions, and should protect himself through proper guarantees from equipment and special equipment Contractors and from subcontractors as their interests may appear.
- E. The guarantee so assumed by the Contractor and as work of this Section is as follows:
  - 1. That the entire mechanical system, including plumbing, heating, and air-conditioning system shall be quiet in operation.
  - 2. That the circulation of water shall be complete and even.
  - 3. That all pipes, conduit, and connections shall be perfectly free from foreign matter and pockets and that all other obstructions to the free passage of air, water, liquid, sewage, and vent shall be removed.
  - 4. That he shall make promptly and free of charge, upon notice from the Owner, any necessary repairs due to defective workmanship or materials that may occur during a period of one year from date of Substantial Completion.
  - 5. That all specialties, mechanical, and patent devices incorporated in these systems shall be adjusted in a manner that each shall develop its maximum efficiency in the

operation of the system; i.e., diffusers shall deliver the designed amount of air shown on drawings, thermostats shall operate to the specified limits, etc.

6. All equipment and the complete mechanical, ductwork, piping and plumbing systems shall be guaranteed for a period of one year from the date of the Architect's Certificate of Substantial Completion, this includes all mechanical, ductwork, piping and plumbing equipment and products and is not limited to boiler, chillers, coils, fans, filters etc. Any equipment supplier not willing to comply with this guarantee period shall not submit a bid price for this project. The Contractor shall be responsible for a 100-percent guarantee for the system and all items of equipment for this period. If the contractor needs to provide temporary heating or cooling to the building and or needs to insure systems are installed properly and or to meet the project schedule the guaranteed of all systems and equipment shall be as indicated above, on year from the date of the Architect's Certificate of Substantial Completion.
7. All filters used during construction shall be replaced just before equipment is turned over to the Owner, and all required equipment and parts shall be oiled. Any worn parts shall also be replaced.
8. If any systems or equipment is used for temporary heating or cooling the systems shall be protected so they remain clean. I.e. if the ductwork systems are used temporary filters and a filter holder (not duct-taped to ducts or grilles) shall be installed to insure the systems and the equipment remain clean.

#### 1.29 CURBS

- A. Unless otherwise noted in these specifications or on the documents all roof curbs for all equipment are to be provided by Division 22 and 23.

#### 1.30 TEST RUN

- A. The Mechanical Contractor shall operate the mechanical system for a minimum of 30 days to prove the operation of the system.

#### 1.31 EQUIPMENT STARTUP AND CHECKOUT

- A. Each major piece of equipment shall be started and checked out by an authorized representative of the equipment manufacturer. A certificate indicating the equipment is operating to the satisfaction of the manufacturer shall be provided and shall be included in the commissioning report.
- B. This contractor shall coordinate commissioning procedures and activities with the commissioning agent.

#### 1.32 DEMOLITION

- A. General: Demolish and remove existing construction only to the extent required by new construction and as indicated. Use methods required to complete the Work within limitations of governing regulations and as follows:

- B. Proceed with demolition systematically, from higher to lower level. Complete selective demolition operations above each floor or tier before disturbing supporting members on the next lower level.
- C. Neatly cut openings and holes plumb, square, and true to dimensions required. Use cutting methods least likely to damage construction to remain or adjoining construction. Use hand tools or small power tools designed for sawing or grinding, not hammering and chopping, to minimize disturbance of adjacent surfaces. Temporarily cover openings to remain.
- D. Cut or drill from the exposed or finished side into concealed surfaces to avoid marring existing finished surfaces.
- E. Do not use cutting torches until work area is cleared of flammable materials. At concealed spaces, such as duct and pipe interiors, verify condition and contents of hidden space before starting flame-cutting operations. Maintain portable fire-suppression devices during flame-cutting operations.
- F. Maintain adequate ventilation when using cutting torches.
- G. Remove decayed, vermin-infested, or otherwise dangerous or unsuitable materials and promptly dispose of off-site.
- H. Remove structural framing members and lower to ground by method suitable to avoid free fall and to prevent ground impact or dust generation.
- I. Locate selective demolition equipment and remove debris and materials so as not to impose excessive loads on supporting walls, floors, or framing.
- J. Dispose of demolished items and materials promptly.
- K. Return elements of construction and surfaces that are to remain to condition existing before selective demolition operations began.
- L. Existing Facilities: Comply with building manager's requirements for using and protecting elevators, stairs, walkways, loading docks, building entries, and other building facilities during selective demolition operations.
- M. Concrete: Demolish in sections. Cut concrete full depth at junctures with construction to remain and at regular intervals, using power-driven saw, then remove concrete between saw cuts.
- N. Masonry: Demolish in small sections. Cut masonry at junctures with construction to remain, using power-driven saw, and then remove masonry between saw cuts.
- O. Concrete Slabs-on-Grade: Saw-cut perimeter of area to be demolished, then break up and remove.
- P. Air-Conditioning Equipment: Remove equipment without releasing refrigerants.

END OF SECTION

**SECTION 23 01 50 - TEMPORARY USE OF EQUIPMENT AND SYSTEMS**

## PART 1 - GENERAL

## 1.1 SUMMARY

- A. This section includes requirements for temporary use of equipment and systems and any other items that are used during the construction of the project.

## 1.2 EQUIPMENT OR SYSTEMS NEEDED TO OPERATE BEFORE CONTRACT COMPLETION

- A. If the contractor needs to provide temporary heating or cooling to the building and or needs to insure systems are installed properly for start up and or to meet the project schedule the guaranteed of all systems and equipment shall be for one year from the date of the Architect's Certificate of Substantial Completion.

All equipment and the complete mechanical, ductwork, piping and plumbing systems shall be guaranteed for a period of one year from the date of the Architect's Certificate of Substantial Completion, this includes all mechanical, ductwork, piping and plumbing equipment and products and is not limited to boiler, chillers, coils, fans, filters etc. Any contractor or equipment supplier who is not willing to comply with this guarantee period shall not submit a bid price for this project. The Contractor shall be responsible for a 100-percent guarantee for the systems and all items of equipment for this period.

All filters used during construction shall be replaced just before equipment is turned over to the Owner, and all required equipment and parts shall be oiled. Any worn parts shall also be replaced.

If any systems or equipment is used for temporary heating or cooling the systems shall be protected so they remain clean. I.e. if the ductwork systems are used temporary filters and a filter holder (not duct-taped to ducts or grilles) shall be installed to insure the systems and the equipment remain clean. All return air openings shall be protected with a metal filter frame and filters.

## 1.3 TEMPORARY EQUIPMENT OR SYSTEM SUBMITTALS

- A. If it is determined by the project or contractor that equipment or systems are needed to operate to provide heating, cooling or other needed services this division shall submit a document indicating what measures will be taken to insure the safe and proper operation of the equipment, systems and personal associated with the operation, this document shall be submitted to the engineer for approval. This plan shall show connections of equipment, utility hookups (if required) staging areas etc.

## 1.4 QUALITY ASSURANCE

- A. Electric Service: Comply with NECA, NEMA, and UL standards and regulations for temporary electric service. Install service to comply with NFPA 70.



- B. Tests and Inspections: Arrange for authorities having jurisdiction to test and inspect each temporary utility before use. Obtain required certifications and permits.
- C. Accessible Temporary Egress: Comply with applicable provisions in the U.S. Architectural & Transportation Barriers Compliance Board's ADA-ABA Accessibility Guidelines.
- D. SMACNA: The latest standard from SSMACNA shall apply.

## 1.5 PROJECT CONDITIONS

- A. Temporary Use of equipment or systems: Engage installer of each permanent service to assume responsibility for operation, maintenance, and protection of each permanent service during its use until the facility has been accepted by the owner regardless of previously assigned responsibilities.

## PART 2 - PRODUCTS

### 2.1 EQUIPMENT

- A. Fire Extinguishers: Portable, UL rated; with class and extinguishing agent as required by locations and classes of fire exposures.
- B. HVAC Equipment: Unless Owner authorizes use of permanent HVAC system, provide vented, self-contained, liquid-propane-gas or fuel-oil heaters and cooling units if required with individual space thermostatic control.
  - 1. Use of gasoline-burning space heaters, open-flame heaters, or salamander-type heating units is prohibited.
  - 2. Heating Units: Listed and labeled for type of fuel being consumed, by a testing agency acceptable to authorities having jurisdiction, and marked for intended use.
  - 3. Permanent HVAC System: If Owner authorizes use of permanent HVAC system for temporary use during construction, provide filters with MERV of 8 at each return air opening in system and remove at end of construction. These filters are to be installed in a filter housing frame and are not to be duct taped. Clean HVAC system as required in Division 01 Section "Closeout Procedures.

## PART 3 - EXECUTION

### 3.1 INSTALLATION, GENERAL

- A. Locate equipment where they will serve Project adequately and result in minimum interference with performance of the Work. Relocate and modify equipment and systems as required by progress of the Work.
  - 1. Locate equipment to limit site disturbance as specified in Division 01 Section "Summary."

### 3.2 TEMPORARY UTILITY INSTALLATION

- A. General: Install temporary service or connect to existing service.
  - 1. Arrange with utility company, Owner, and existing users for time when service can be interrupted, if necessary, to make connections for temporary services.
- B. Water Service: Install water service and distribution piping in sizes and pressures adequate for construction.
- C. Heating and Cooling: Provide temporary heating and cooling required by construction activities for curing or drying of completed installations or for protecting installed construction from adverse effects of low temperatures or high humidity. Select equipment that will not have a harmful effect on completed installations or elements being installed.
- D. Ventilation and Humidity Control: Provide temporary ventilation required by construction activities for curing or drying of completed installations or for protecting installed construction from adverse effects of high humidity. Select equipment that will not have a harmful effect on completed installations or elements being installed. Coordinate ventilation requirements to produce ambient condition required and minimize energy consumption.

### 3.3 OPERATION, TERMINATION, AND REMOVAL

- A. Maintenance: Maintain equipment and systems in good operating condition until removal.
  - 1. Maintain operation of temporary enclosures, heating, cooling, humidity control, ventilation, and similar equipment and systems on a 24-hour basis where required to achieve indicated results and to avoid possibility of damage.
- B. Termination and Removal: Remove each temporary facility or equipment when need for its service has ended, when it has been replaced by authorized use of a permanent facility, or no later than Substantial Completion. Complete or, if necessary, restore permanent construction that may have been delayed because of interference with temporary facility. Repair damaged Work, clean exposed surfaces, and replace construction that cannot be satisfactorily repaired.
  - 1. Materials equipment that constitute temporary equipment are property of Contractor.
  - 2. At Substantial Completion, repair, renovate, and clean permanent equipment and systems used during construction period. Comply with final cleaning requirements specified in Division 01 Section "Closeout Procedures."

### 3.4 EQUIPMENT STARTUP AND CHECKOUT

- A. Each major piece of equipment shall be started and checked out by an authorized representative of the equipment manufacturer at substantial completion. A

certificate indicating the equipment is operating to the satisfaction of the manufacturer shall be provided and shall be included in the commissioning report.

END OF SECTION

**SECTION 23 05 00 - COMMON WORK RESULTS FOR HVAC**

## PART 1 - GENERAL

## 1.1 RELATED DOCUMENTS

- A. Drawings and general provisions of the Contract, including General and Supplementary Conditions and Division 01 Specification Sections, apply to this Section.

## 1.2 SUMMARY

- A. This Section includes the following:
  - 1. Piping materials and installation instructions common to most piping systems.
  - 2. Transition fittings.
  - 3. Dielectric fittings.
  - 4. Mechanical sleeve seals.
  - 5. Sleeves.
  - 6. Escutcheons.
  - 7. Grout.
  - 8. Equipment installation requirements common to equipment sections.
  - 9. Painting and finishing.
  - 10. Concrete bases.
  - 11. Supports and anchorages.
  - 12. Link-Seal

## 1.3 DEFINITIONS

- A. Finished Spaces: Spaces other than mechanical and electrical equipment rooms, furred spaces, pipe and duct chases, unheated spaces immediately below roof, spaces above ceilings, unexcavated spaces, and crawlspaces.
- B. Exposed, Interior Installations: Exposed to view indoors. Examples include finished occupied spaces, mechanical equipment rooms, accessible pipe shafts, accessible plumbing chases, and accessible tunnels.
- C. Exposed, Exterior Installations: Exposed to view outdoors or subject to outdoor ambient temperatures and weather conditions. Examples include rooftop locations.
- D. Concealed, Interior Installations: Concealed from view and protected from physical contact by building occupants. Examples include above ceilings and chases.
- E. Concealed, Exterior Installations: Concealed from view and protected from weather conditions and physical contact by building occupants but subject to outdoor ambient temperatures. Examples include installations within unheated shelters.
- F. The following are industry abbreviations for plastic materials:

1. CPVC: Chlorinated polyvinyl chloride plastic.
2. PVC: Polyvinyl chloride plastic.

G. The following are industry abbreviations for rubber materials:

1. EPDM: Ethylene-propylene-diene terpolymer rubber.
2. NBR: Acrylonitrile-butadiene rubber.

#### 1.4 SUBMITTALS

A. Product Data: For the following:

1. Transition fittings.
2. Dielectric fittings.
3. Mechanical sleeve seals.
4. Escutcheons.

B. Welding certificates.

#### 1.5 QUALITY ASSURANCE

A. Steel Support Welding: Qualify processes and operators according to AWS D1.1, "Structural Welding Code--Steel."

B. Steel Pipe Welding: Qualify processes and operators according to ASME Boiler and Pressure Vessel Code: Section IX, "Welding and Brazing Qualifications."

1. Comply with provisions in ASME B31 Series, "Code for Pressure Piping."
2. Certify that each welder has passed AWS qualification tests for welding processes involved and that certification is current.

C. Electrical Characteristics for HVAC Equipment: Equipment of higher electrical characteristics may be furnished provided such proposed equipment is approved in writing and connecting electrical services, circuit breakers, and conduit sizes are appropriately modified. If minimum energy ratings or efficiencies are specified, equipment shall comply with requirements.

#### 1.6 DELIVERY, STORAGE, AND HANDLING

A. Deliver pipes and tubes with factory-applied end caps. Maintain end caps through shipping, storage, and handling to prevent pipe end damage and to prevent entrance of dirt, debris, and moisture.

B. Store plastic pipes protected from direct sunlight. Support to prevent sagging and bending.

#### 1.7 COORDINATION

A. Arrange for pipe spaces, chases, slots, and openings in building structure during progress of construction, to allow for HVAC installations.

- B. Coordinate installation of required supporting devices and set sleeves in poured-in-place concrete and other structural components as they are constructed.
- C. Coordinate requirements for access panels and doors for HVAC items requiring access that are concealed behind finished surfaces. Access panels and doors are specified in Division 08 Section "Access Doors and Frames."

## PART 2 - PRODUCTS

### 2.1 MANUFACTURERS

- A. In other Part 2 articles where subparagraph titles below introduce lists, the following requirements apply for product selection:
  - 1. Manufacturers: Subject to compliance with requirements, provide products by the manufacturers specified.

### 2.2 PIPE, TUBE, AND FITTINGS

- A. Refer to individual Division 23 piping Sections for pipe, tube, and fitting materials and joining methods.
- B. Pipe Threads: ASME B1.20.1 for factory-threaded pipe and pipe fittings.

### 2.3 JOINING MATERIALS

- A. Refer to individual Division 23 piping Sections for special joining materials not listed below.
- B. Pipe-Flange Gasket Materials: Suitable for chemical and thermal conditions of piping system contents.
  - 1. ASME B16.21, nonmetallic, flat, asbestos-free, 1/8-inch maximum thickness unless thickness or specific material is indicated.
    - a. Full-Face Type: For flat-face, Class 125, cast-iron and cast-bronze flanges.
    - b. Narrow-Face Type: For raised-face, Class 250, cast-iron and steel flanges.
  - 2. AWWA C110, rubber, flat face, 1/8 inch thick, unless otherwise indicated; and full-face or ring type, unless otherwise indicated.
- C. Flange Bolts and Nuts: ASME B18.2.1, carbon steel, unless otherwise indicated.
- D. Solder Filler Metals: ASTM B 32, lead-free alloys. Include water-flushable flux according to ASTM B 813.
- E. Brazing Filler Metals: AWS A5.8, BCuP Series, copper-phosphorus alloys for general-duty brazing, unless otherwise indicated; and AWS A5.8, BAg1, silver alloy for refrigerant piping, unless otherwise indicated.

- F. Welding Filler Metals: Comply with AWS D10.12 for welding materials appropriate for wall thickness and chemical analysis of steel pipe being welded.

## 2.4 TRANSITION FITTINGS

- A. Plastic-to-Metal Transition Fittings: CPVC and PVC one-piece fitting with manufacturer's Schedule 80 equivalent dimensions; one end with threaded brass insert, and one solvent-cement-joint end.

- 1. Manufacturers:

- a. Eslon Thermoplastics.

- B. Plastic-to-Metal Transition Adaptors: One-piece fitting with manufacturer's SDR 11 equivalent dimensions; one end with threaded brass insert, and one solvent-cement-joint end.

- 1. Manufacturers:

- a. Thompson Plastics, Inc.

## 2.5 DIELECTRIC FITTINGS

- A. General: Assembly or fitting with insulating material isolating joined dissimilar metals, to prevent galvanic action and stop corrosion.

- B. Description: Combination of copper alloy and ferrous; threaded, solder, plain, and weld-neck end types and matching piping system materials.

- C. Insulating Material: Suitable for system fluid, pressure, and temperature.

- D. Dielectric Unions: Factory-fabricated, union assembly, for 250-psig minimum working pressure at 180 deg F.

- E. Dielectric Flanges: Factory-fabricated, companion-flange assembly, for 150- or 300-psig minimum working pressure as required to suit system pressures.

- F. Dielectric-Flange Insulation Kits: Field-assembled, companion-flange assembly, full-face or ring type. Components include neoprene or phenolic gasket, phenolic or polyethylene bolt sleeves, phenolic washers, and steel backing washers.

- 1. Provide separate companion flanges and steel bolts and nuts for 150- or 300-psig minimum working pressure as required to suit system pressures.

- G. Dielectric Couplings: Galvanized-steel coupling with inert and noncorrosive, thermoplastic lining; threaded ends; and 300-psig minimum working pressure at 225 deg F.

- H. Dielectric Nipples: Electroplated steel nipple with inert and noncorrosive, thermoplastic lining; plain, threaded, or grooved ends; and 300-psig minimum working pressure at 225 deg F.

1. Manufacturers:
  - a. Capitol Manufacturing Co.
  - b. Central Plastics Company.
  - c. Watts Industries, Inc.; Water Products Div

## 2.6 MECHANICAL SLEEVE SEALS

- A. Description: Modular sealing element unit, designed for field assembly, to fill annular space between pipe and sleeve.

1. Manufacturers:
  - a. Advance Products & Systems, Inc.
  - b. Calpico, Inc.
  - c. Metraflex Co.
  - d. Pipeline Seal and Insulator, Inc.
2. Sealing Elements: EPDM interlocking links shaped to fit surface of pipe. Include type and number required for pipe material and size of pipe.
3. Pressure Plates: Stainless steel. Include two for each sealing element.
4. Connecting Bolts and Nuts: Stainless steel of length required to secure pressure plates to sealing elements. Include one for each sealing element.

## 2.7 SLEEVES

- A. Galvanized-Steel Sheet: 0.0239-inch minimum thickness; round tube closed with welded longitudinal joint.
- B. Steel Pipe: ASTM A 53, Type E, Grade B, Schedule 40, galvanized, plain ends.
- C. Cast Iron: Cast or fabricated "wall pipe" equivalent to ductile-iron pressure pipe, with plain ends and integral waterstop, unless otherwise indicated.
- D. Stack Sleeve Fittings: Manufactured, cast-iron sleeve with integral clamping flange. Include clamping ring and bolts and nuts for membrane flashing.
  1. Underdeck Clamp: Clamping ring with set screws.
- E. Molded PVC: Permanent, with nailing flange for attaching to wooden forms.
- F. PVC Pipe: ASTM D 1785, Schedule 40.

## 2.8 ESCUTCHEONS

- A. Description: Manufactured wall and ceiling escutcheons and floor plates, with an ID to closely fit around pipe, tube, and insulation of insulated piping and an OD that completely covers opening.



- B. One-Piece, Deep-Pattern Type: Deep-drawn, box-shaped brass with polished chrome-plated finish.
- C. One-Piece, Cast-Brass Type: With set screw.
  - 1. Finish: Polished chrome-plated and rough brass.
- D. One-Piece, Stamped-Steel Type: With set screw or spring clips and chrome-plated finish.
- E. Split-Plate, Stamped-Steel Type: With concealed hinge, set screw or spring clips, and chrome-plated finish.

## 2.9 GROUT

- A. Description: ASTM C 1107, Grade B, non-shrink and nonmetallic, dry hydraulic-cement grout.
  - 1. Characteristics: Post-hardening, volume-adjusting, non-staining, noncorrosive, nongaseous, and recommended for interior and exterior applications.
  - 2. Design Mix: 5000-psi, 28-day compressive strength.
  - 3. Packaging: Premixed and factory packaged.

## 2.10 LINK-SEAL MODULAR SEAL PRESSURE PLATES

- A. Link-Seal® modular seal pressure plates shall be molded of glass reinforced Nylon Polymer with the following properties:
  - 1. Izod Impact - Notched = 2.05ft-lb/in. per ASTM D-256
  - 2. Flexural Strength @ Yield = 30,750 psi per ASTM D-790
  - 3. Flexural Modulus = 1,124,000 psi per ASTM D-790
  - 4. Elongation Break = 11.07% per ASTM D-638
  - 5. Specific Gravity = 1.38 per ASTM D-792
- B. Models LS200-275-300-315 shall incorporate the most current Link-Seal® Modular Seal design modifications and shall include an integrally molded compression assist boss on the top (bolt entry side) of the pressure plate, which permits increased compressive loading of the rubber sealing element. Models 315-325-340-360-400-410-425-475-500-525-575-600 shall incorporate an integral recess known as a "Hex Nut Interlock" designed to accommodate commercially available fasteners to insure proper thread engagement for the class and service of metal hardware. All pressure plates shall have a permanent identification of the manufacturer's name molded into it.
- C. For fire service, pressure plates shall be steel with 2-part Zinc Dichromate Coating.
- D. Link-Seal® Modular Seal Hardware: All fasteners shall be sized according to latest Link-Seal® modular seal technical data. Bolts, flange hex nuts shall be:
  - 1. 316 Stainless Steel per ASTM F593-95, with a 85,000 psi average tensile strength.

## PART 3 - EXECUTION

## 3.1 PIPING SYSTEMS - COMMON REQUIREMENTS

- A. Install piping according to the following requirements and Division 23 Sections specifying piping systems.
- B. Drawing plans, schematics, and diagrams indicate general location and arrangement of piping systems. Indicated locations and arrangements were used to size pipe and calculate friction loss, expansion, pump sizing, and other design considerations. Install piping as indicated unless deviations to layout are approved on Coordination Drawings.
- C. Install piping in concealed locations, unless otherwise indicated and except in equipment rooms and service areas.
- D. Install piping indicated to be exposed and piping in equipment rooms and service areas at right angles or parallel to building walls. Diagonal runs are prohibited unless specifically indicated otherwise.
- E. Install piping above accessible ceilings to allow sufficient space for ceiling panel removal.
- F. Install piping to permit valve servicing.
- G. Install piping at indicated slopes.
- H. Install piping free of sags and bends.
- I. Install fittings for changes in direction and branch connections.
- J. Install piping to allow application of insulation.
- K. Select system components with pressure rating equal to or greater than system operating pressure.
- L. Install escutcheons for penetrations of walls, ceilings, and floors according to the following:
  - 1. New Piping:
    - a. Piping with Fitting or Sleeve Protruding from Wall: One-piece, deep-pattern type.
    - b. Chrome-Plated Piping: One-piece, cast-brass type with polished chrome-plated finish.
    - c. Insulated Piping: One-piece, stamped-steel type with spring clips.
    - d. Bare Piping at Wall and Floor Penetrations in Finished Spaces: One-piece, cast-brass type with polished chrome-plated finish.
    - e. Bare Piping at Wall and Floor Penetrations in Finished Spaces: One-piece, stamped-steel type.

- f. Bare Piping at Ceiling Penetrations in Finished Spaces: One-piece or split-casting, cast-brass type with polished chrome-plated finish.
    - g. Bare Piping at Ceiling Penetrations in Finished Spaces: One-piece, stamped-steel type or split-plate, stamped-steel type with concealed hinge and set screw.
- M. Install sleeves for pipes passing through concrete and masonry walls and concrete floor and roof slabs.
- N. Install sleeves for pipes passing through concrete and masonry walls, gypsum-board partitions, and concrete floor and roof slabs.
  - 1. Cut sleeves to length for mounting flush with both surfaces.
    - a. Exception: Extend sleeves installed in floors of mechanical equipment areas or other wet areas 2 inches above finished floor level. Extend cast-iron sleeve fittings below floor slab as required to secure clamping ring if ring is specified.
  - 2. Install sleeves in new walls and slabs as new walls and slabs are constructed.
  - 3. Install sleeves that are large enough to provide 1/4-inch annular clear space between sleeve and pipe or pipe insulation. Use the following sleeve materials:
    - a. PVC Steel Pipe Sleeves: For pipes smaller than NPS 6.
    - b. Steel Sheet Sleeves: For pipes NPS 6 and larger, penetrating gypsum-board partitions.
    - c. Stack Sleeve Fittings: For pipes penetrating floors with membrane waterproofing. Secure flashing between clamping flanges. Install section of cast-iron soil pipe to extend sleeve to 2 inches above finished floor level. Refer to Division 07 Section "Sheet Metal Flashing and Trim" for flashing.
      - 1) Seal space outside of sleeve fittings with grout.
  - 4. Except for underground wall penetrations, seal annular space between sleeve and pipe or pipe insulation, using joint sealants appropriate for size, depth, and location of joint. Refer to Division 07 Section "Joint Sealants" for materials and installation.
- O. Aboveground, Exterior-Wall Pipe Penetrations: Seal penetrations using sleeves and mechanical sleeve seals. Select sleeve size to allow for 1-inch annular clear space between pipe and sleeve for installing mechanical sleeve seals.
  - 1. Install steel pipe for sleeves smaller than 6 inches in diameter.
  - 2. Install cast-iron "wall pipes" for sleeves 6 inches and larger in diameter.
  - 3. Mechanical Sleeve Seal Installation: Select type and number of sealing elements required for pipe material and size. Position pipe in center of sleeve. Assemble mechanical sleeve seals and install in annular space between pipe and sleeve. Tighten bolts against pressure plates that cause sealing elements to expand and make watertight seal.
- P. Underground, Exterior-Wall Pipe Penetrations: Install cast-iron "wall pipes" for sleeves. Seal pipe penetrations using mechanical sleeve seals. Select sleeve size to allow for 1-

inch annular clear space between pipe and sleeve for installing mechanical sleeve seals.

1. Mechanical Sleeve Seal Installation: Select type and number of sealing elements required for pipe material and size. Position pipe in center of sleeve. Assemble mechanical sleeve seals and install in annular space between pipe and sleeve. Tighten bolts against pressure plates that cause sealing elements to expand and make watertight seal.
- Q. Fire-Barrier Penetrations: Maintain indicated fire rating of walls, partitions, ceilings, and floors at pipe penetrations. Seal pipe penetrations with firestop materials. Refer to Division 07 Section "Penetration Firestopping" for materials.
- R. Verify final equipment locations for roughing-in.
- S. Refer to equipment specifications in other Sections of these Specifications for roughing-in requirements.

### 3.2 PIPING JOINT CONSTRUCTION

- A. Join pipe and fittings according to the following requirements and Division 23 Sections specifying piping systems.
- B. Ream ends of pipes and tubes and remove burrs. Bevel plain ends of steel pipe.
- C. Remove scale, slag, dirt, and debris from inside and outside of pipe and fittings before assembly.
- D. Soldered Joints: Apply ASTM B 813, water-flushable flux, unless otherwise indicated, to tube end. Construct joints according to ASTM B 828 or CDA's "Copper Tube Handbook," using lead-free solder alloy complying with ASTM B 32.
- E. Brazed Joints: Construct joints according to AWS's "Brazing Handbook," "Pipe and Tube" Chapter, using copper-phosphorus brazing filler metal complying with AWS A5.8.
- F. Threaded Joints: Thread pipe with tapered pipe threads according to ASME B1.20.1. Cut threads full and clean using sharp dies. Ream threaded pipe ends to remove burrs and restore full ID. Join pipe fittings and valves as follows:
1. Apply appropriate tape or thread compound to external pipe threads unless dry seal threading is specified.
  2. Damaged Threads: Do not use pipe or pipe fittings with threads that are corroded or damaged. Do not use pipe sections that have cracked or open welds.
- G. Welded Joints: Construct joints according to AWS D10.12, using qualified processes and welding operators according to Part 1 "Quality Assurance" Article.
- H. Flanged Joints: Select appropriate gasket material, size, type, and thickness for service application. Install gasket concentrically positioned. Use suitable lubricants on bolt threads.

### 3.3 PIPING CONNECTIONS

- A. Make connections according to the following, unless otherwise indicated:
  - 1. Install unions, in piping NPS 2 and smaller, adjacent to each valve and at final connection to each piece of equipment.
  - 2. Install flanges, in piping NPS 2-1/2 and larger, adjacent to flanged valves and at final connection to each piece of equipment.
  - 3. Dry Piping Systems: Install dielectric unions and flanges to connect piping materials of dissimilar metals.
  - 4. Wet Piping Systems: Install dielectric coupling and nipple fittings to connect piping materials of dissimilar metals.

### 3.4 EQUIPMENT INSTALLATION - COMMON REQUIREMENTS

- A. Install equipment to allow maximum possible headroom unless specific mounting heights are not indicated.
- B. Install equipment level and plumb, parallel and perpendicular to other building systems and components in exposed interior spaces, unless otherwise indicated.
- C. Install HVAC equipment to facilitate service, maintenance, and repair or replacement of components. Connect equipment for ease of disconnecting, with minimum interference to other installations. Extend grease fittings to accessible locations.
- D. Install equipment to allow right of way for piping installed at required slope.

### 3.5 PAINTING

- A. Painting of HVAC systems, equipment, and components is specified in Division 09 Sections "Interior Painting" and "Exterior Painting."
- B. Damage and Touchup: Repair marred and damaged factory-painted finishes with materials and procedures to match original factory finish.

### 3.6 CONCRETE BASES

- A. Concrete Bases: Anchor equipment to concrete base according to equipment manufacturer's written instructions and according to seismic codes at Project.
  - 1. Construct concrete bases of dimensions indicated, but not less than 4 inches larger in both directions than supported unit.
  - 2. Install dowel rods to connect concrete base to concrete floor. Unless otherwise indicated, install dowel rods on 18-inch centers around the full perimeter of the base.
  - 3. Install epoxy-coated anchor bolts for supported equipment that extend through concrete base, and anchor into structural concrete floor.

4. Place and secure anchorage devices. Use supported equipment manufacturer's setting drawings, templates, diagrams, instructions, and directions furnished with items to be embedded.
5. Install anchor bolts to elevations required for proper attachment to supported equipment.
6. Install anchor bolts according to anchor-bolt manufacturer's written instructions.
7. Use 3000-psi, 28-day compressive-strength concrete and reinforcement as specified in Division 03 Section "Miscellaneous Cast-in-Place Concrete."

### 3.7 ERECTION OF METAL SUPPORTS AND ANCHORAGES

- A. Refer to Division 5 Section "Metal Fabrications" for structural steel.
- B. Cut, fit, and place miscellaneous metal supports accurately in location, alignment, and elevation to support and anchor HVAC materials and equipment.
- C. Field Welding: Comply with AWS D1.1.

### 3.8 GROUTING

- A. Mix and install grout for HVAC equipment base bearing surfaces, pump and other equipment base plates, and anchors.
- B. Clean surfaces that will come into contact with grout.
- C. Provide forms as required for placement of grout.
- D. Avoid air entrapment during placement of grout.
- E. Place grout, completely filling equipment bases.
- F. Place grout on concrete bases and provide smooth bearing surface for equipment.
- G. Place grout around anchors.
- H. Cure placed grout.

### 3.9 LINK SEAL

- A. Provide Link Seal at all piping penetrations from the outside.

END OF SECTION

**SECTION 23 05 13 - COMMON MOTOR REQUIREMENTS FOR HVAC EQUIPMENT**

## PART 1 - GENERAL

## 1.1 RELATED DOCUMENTS

- A. Drawings and general provisions of the Contract, including General and Supplementary Conditions and Division 01 Specification Sections, apply to this Section.

## 1.2 SUMMARY

- A. Section includes general requirements for single-phase and polyphase, general-purpose, horizontal, small and medium, squirrel-cage induction motors for use on ac power systems up to 600 V and installed at equipment manufacturer's factory or shipped separately by equipment manufacturer for field installation.

## 1.3 COORDINATION

- A. Coordinate features of motors, installed units, and accessory devices to be compatible with the following:
  - 1. Motor controllers.
  - 2. Torque, speed, and horsepower requirements of the load.
  - 3. Ratings and characteristics of supply circuit and required control sequence.
  - 4. Ambient and environmental conditions of installation location.

## PART 2 - PRODUCTS

## 2.1 GENERAL MOTOR REQUIREMENTS

- A. Comply with requirements in this Section except when the requirements in equipment schedules, other specification sections, drawing notes or in other contract documents are more stringent.
- B. Comply with NEMA MG 1 unless otherwise indicated.

## 2.2 MOTOR CHARACTERISTICS

- A. Duty: Continuous duty at ambient temperature of 40 deg C and at altitude of 3300 feet above sea level.
- B. Capacity and Torque Characteristics: Sufficient to start, accelerate, and operate connected loads at designated speeds, at installed altitude and environment, with indicated operating sequence, and without exceeding nameplate ratings or considering service factor.

- C. Motors 3/4 HP and larger: Polyphase.
- D. Motors smaller than 3/4 HP: Single phase.
- E. All motors shall have ASTM Grade 5 hardware that is Yellow Zinc-dichromate plated.

### 2.3 POLYPHASE MOTORS

- A. Description: NEMA MG 1, Design B, medium induction motor.
- B. Efficiency: Energy efficient, as defined in NEMA MG 1.
- C. Service Factor: 1.15.
- D. Rotor: Random-wound, squirrel cage.
- E. Bearings: Regreasable, shielded, antifriction ball bearings suitable for radial and thrust loading.
- F. Temperature Rise: Match insulation rating.
- G. Insulation: Class F.
- H. Code Letter Designation:
  - 1. Motors 15 HP and Larger: NEMA starting Code F or Code G.
  - 2. Motors smaller than 15 HP: Manufacturer's standard starting characteristic.
- I. Enclosure Material: Cast iron for motor frame sizes 324T and larger; rolled steel for motor frame sizes smaller than 324T.

### 2.4 POLYPHASE MOTORS WITH ADDITIONAL REQUIREMENTS

- A. Motors Used with Reduced-Voltage and Multispeed Controllers: Match wiring connection requirements for controller with required motor leads. Provide terminals in motor terminal box, suited to control method.
- B. Motors Used with Variable Frequency Controllers: Ratings, characteristics, and features coordinated with and approved by controller manufacturer.
  - 1. Windings: Copper magnet wire with moisture-resistant insulation varnish, designed and tested to resist transient spikes, high frequencies, and short time rise pulses produced by pulse-width modulated inverters.
  - 2. Energy- and Premium-Efficient Motors: Class B temperature rise; Class F insulation.
  - 3. Inverter-Duty Motors: Class F temperature rise; Class H insulation.
  - 4. Thermal Protection: Comply with NEMA MG 1 requirements for thermally protected motors.
  - 5. Shaft Grounding Ring: Microfiber type.
    - a. Provide grounded discharge path for VFD induced voltage in the shaft to prevent arcing in the motor bearings.



## 2.5 ELECTRONICALLY COMMUTATED MOTOR (ECM)

1. Motor enclosures: Open type
2. Motor to be a DC electronic commutation type motor (ECM).
  - a. AC induction type motors are not acceptable.
3. Permanently lubricated motor with heavy duty ball bearing
4. Internal motor circuitry to convert AC power supplied to the fan to DC power to operate the motor.
5. Speed controllable to 20% of full speed (80% turndown).
  - a. Potentiometer dial mounted at the motor speed controller
  - b. 0-10 VDC signal.
6. 85% efficient at all speeds minimum.
7. Motors smaller than 2.0 hp.

## 2.6 SINGLE-PHASE MOTORS

- A. Motors larger than 1/20 hp shall be one of the following, to suit starting torque and requirements of specific motor application:
  1. Permanent-split capacitor.
  2. Split phase.
  3. Capacitor start, inductor run.
  4. Capacitor start, capacitor run.
- B. Bearings: Prelubricated, antifriction ball bearings or sleeve bearings suitable for radial and thrust loading.
- C. Motors 1/20 HP and Smaller: Shaded-pole type.
- D. Thermal Protection: Internal protection to automatically open power supply circuit to motor when winding temperature exceeds a safe value calibrated to temperature rating of motor insulation. Thermal-protection device shall automatically reset when motor temperature returns to normal range, unless otherwise indicated.

## PART 3 - EXECUTION (Not Applicable)

END OF SECTION

**SECTION 23 05 17 - SLEEVES AND SLEEVE SEALS FOR HVAC PIPING**

## PART 1 - GENERAL

## 1.1 RELATED DOCUMENTS

- A. Drawings and general provisions of the Contract, including General and Supplementary Conditions and Division 01 Specification Sections, apply to this Section.

## 1.2 SUMMARY

- A. Section Includes:
  - 1. Sleeves.
  - 2. Sleeve-seal systems.
  - 3. Grout.

## 1.3 ACTION SUBMITTALS

- A. Product Data: For each type of product indicated.

## PART 2 - PRODUCTS

## 2.1 SLEEVES

- A. Cast-Iron Wall Pipes: Cast or fabricated of cast or ductile iron and equivalent to ductile-iron pressure pipe, with plain ends and integral waterstop unless otherwise indicated.
- B. Galvanized-Steel Wall Pipes: ASTM A 53, Schedule 40, with plain ends and welded steel collar; zinc coated.
- C. Galvanized-Steel-Pipe Sleeves: ASTM A 53, Type E, Grade B, Schedule 40, zinc coated, with plain ends.
- D. PVC-Pipe Sleeves: ASTM D 1785, Schedule 40.
- E. Galvanized-Steel-Sheet Sleeves: 0.0239-inch minimum thickness; round tube closed with welded longitudinal joint.

## 2.2 SLEEVE-SEAL SYSTEMS

- A. Manufacturers: Subject to compliance with requirements, provide products by one of the following:
  - 1. Advance Products & Systems, Inc.
  - 2. CALPICO, Inc.

3. Metraflex Company (The).
  4. Pipeline Seal and Insulator, Inc.
  5. Proco Products, Inc.
- B. Description: Modular sealing-element unit, designed for field assembly, for filling annular space between piping and sleeve.
1. Sealing Elements: EPDM-rubber interlocking links shaped to fit surface of pipe. Include type and number required for pipe material and size of pipe.
  2. Pressure Plates: Stainless steel.
  3. Connecting Bolts and Nuts: Stainless steel of length required to secure pressure plates to sealing elements.

### 2.3 GROUT

- A. Standard: ASTM C 1107/C 1107M, Grade B, post-hardening and volume-adjusting, dry, hydraulic-cement grout.
- B. Characteristics: Nonshrink; recommended for interior and exterior applications.
- C. Design Mix: 5000-psi, 28-day compressive strength.
- D. Packaging: Premixed and factory packaged.

## PART 3 - EXECUTION

### 3.1 SLEEVE INSTALLATION

- A. Install sleeves for piping passing through penetrations in floors, partitions, roofs, and walls.
- B. For sleeves that will have sleeve-seal system installed, select sleeves of size large enough to provide 1-inch annular clear space between piping and concrete slabs and walls.
1. Sleeves are not required for core-drilled holes.
- C. Install sleeves in concrete floors, concrete roof slabs, and concrete walls as new slabs and walls are constructed.
1. Permanent sleeves are not required for holes in slabs formed by molded-PE or -PP sleeves.
  2. Cut sleeves to length for mounting flush with both surfaces.
    - a. Exception: Extend sleeves installed in floors of mechanical equipment areas or other wet areas 2 inches above finished floor level.
  3. Using grout, seal the space outside of sleeves in slabs and walls without sleeve-seal system.
- D. Install sleeves for pipes passing through interior partitions.
1. Cut sleeves to length for mounting flush with both surfaces.
  2. Install sleeves that are large enough to provide 1/4-inch annular clear space between sleeve and pipe or pipe insulation.

3. Seal annular space between sleeve and piping or piping insulation; use joint sealants appropriate for size, depth, and location of joint. Comply with requirements for sealants specified in Section 079200 "Joint Sealants."
- E. Fire-Barrier Penetrations: Maintain indicated fire rating of walls, partitions, ceilings, and floors at pipe penetrations. Seal pipe penetrations with firestop materials. Comply with requirements for firestopping specified in Section 078413 "Penetration Firestopping."

### 3.2 SLEEVE-SEAL-SYSTEM INSTALLATION

- A. Install sleeve-seal systems in sleeves in exterior concrete walls and slabs-on-grade at service piping entries into building.
- B. Select type, size, and number of sealing elements required for piping material and size and for sleeve ID or hole size. Position piping in center of sleeve. Center piping in penetration, assemble sleeve-seal system components, and install in annular space between piping and sleeve. Tighten bolts against pressure plates that cause sealing elements to expand and make a watertight seal.

### 3.3 SLEEVE AND SLEEVE-SEAL SCHEDULE

- A. Use sleeves and sleeve seals for the following piping-penetration applications:
  1. Exterior Concrete Walls above Grade:
    - a. Piping Smaller Than NPS 6: Cast-iron wall sleeves.
    - b. Piping NPS 6 and Larger: Cast-iron wall sleeves.
    - c.
  2. Exterior Concrete Walls below Grade:
    - a. Piping Smaller Than NPS 6: Cast-iron wall sleeves with sleeve-seal system.
      - 1) Select sleeve size to allow for 1-inch annular clear space between piping and sleeve for installing sleeve-seal system.
    - b. Piping NPS 6 and Larger: Cast-iron wall sleeves with sleeve-seal system.
      - 1) Select sleeve size to allow for 1-inch annular clear space between piping and sleeve for installing sleeve-seal system.
  3. Concrete Slabs-on-Grade:
    - a. Piping Smaller Than NPS 6: Cast-iron wall sleeves with sleeve-seal system.
      - 1) Select sleeve size to allow for 1-inch annular clear space between piping and sleeve for installing sleeve-seal system.
    - b. Piping NPS 6 and Larger: Cast-iron wall sleeves with sleeve-seal system.
      - 1) Select sleeve size to allow for 1-inch annular clear space between piping and sleeve for installing sleeve-seal system.
  4. Concrete Slabs above Grade:
    - a. Piping Smaller Than NPS 6: Galvanized-steel-pipe sleeves.
    - b. Piping NPS 6 and Larger: Galvanized-steel-pipe sleeves.
  5. Interior Partitions:
    - a. Piping Smaller Than NPS 6: Galvanized-steel-pipe sleeves.
    - b. Piping NPS 6 and Larger: Galvanized-steel-sheet sleeves.

END OF SECTION

**SECTION 23 05 18 - ESCUTCHEONS FOR HVAC PIPING**

## PART 1 - GENERAL

## 1.1 RELATED DOCUMENTS

- A. Drawings and general provisions of the Contract, including General and Supplementary Conditions and Division 01 Specification Sections, apply to this Section.

## 1.2 SUMMARY

- A. Section Includes:
  - 1. Escutcheons.

## 1.3 ACTION SUBMITTALS

- A. Product Data: For each type of product indicated.

## PART 2 - PRODUCTS

## 2.1 ESCUTCHEONS

- A. One-Piece, Cast-Brass Type: With polished, chrome-plated or rough-brass finish and setscrew fastener.
- B. One-Piece, Deep-Pattern Type: Deep-drawn, box-shaped brass with chrome-plated finish and spring-clip fasteners.
- C. One-Piece, Stamped-Steel Type: With chrome-plated finish and spring-clip fasteners.

## PART 3 - EXECUTION

## 3.1 INSTALLATION

- A. Install escutcheons for piping penetrations of walls, ceilings, and finished floors.
- B. Install escutcheons with ID to closely fit around pipe, tube, and insulation of insulated piping and with OD that completely covers opening.
  - 1. Escutcheons for New Piping:
    - a. Piping with Fitting or Sleeve Protruding from Wall: One-piece, deep-pattern type with polished, chrome-plated finish.

- b. Chrome-Plated Piping: One-piece, cast-brass type with polished, chrome-plated finish.
- c. Insulated Piping: One-piece, stamped-steel type with chrome-plated finish. Retain one of first two subparagraphs below.
- d. Bare Piping 2 inch and Smaller at Wall and Floor Penetrations in Finished Spaces: One-piece, cast-brass type with polished, chrome-plated finish.
- e. Bare Piping Larger than 2 inch at Wall and Floor Penetrations in Finished Spaces: One-piece, stamped-steel type with polished, chrome-plated finish.
- f. Bare Piping 2 inch and Smaller at Ceiling Penetrations in Finished Spaces: One-piece, cast-brass type with polished, chrome-plated finish.
- g. Bare Piping Larger than 2 inch at Ceiling Penetrations in Finished Spaces: One-piece, stamped-steel type with polished, chrome-plated finish.
- h. Bare Piping 2 inch and Smaller in Unfinished Service Spaces: One-piece, cast-brass type with polished, chrome-plated.
- i. Bare Piping Larger than 2 inch in Unfinished Service Spaces: One-piece, stamped-steel type with polished, chrome-plated finish.
- j. Bare Piping 2 inch and Smaller in Equipment Rooms: One-piece, cast-brass type with polished, chrome-plated finish.
- k. Bare Piping in Equipment Rooms Larger than 2 inch: One-piece, stamped-steel type with chrome- or cadmium-plated finish.

### 3.2 FIELD QUALITY CONTROL

- A. Replace broken and damaged escutcheons and floor plates using new materials.

END OF SECTION

**SECTION 23 05 19 - METERS AND GAGES FOR HVAC**

## PART 1 - GENERAL

## 1.1 RELATED DOCUMENTS

- A. Drawings and general provisions of the Contract, including General and Supplementary Conditions and Division 01 Specification Sections, apply to this Section.

## 1.2 SUMMARY

- A. Section Includes:
  - 1. Liquid-in-glass thermometers.
  - 2. Thermowells.
  - 3. Pressure gages.
  - 4. Gage attachments.
  - 5. Test plugs.
  - 6. Test-plug kits.
  - 7. Flowmeters.

## 1.3 ACTION SUBMITTALS

- A. Product Data: For each type of product indicated.
- B. Wiring Diagrams: For power, signal, and control wiring.

## 1.4 INFORMATIONAL SUBMITTALS

- A. Product Certificates: For each type of meter and gage, from manufacturer.

## 1.5 CLOSEOUT SUBMITTALS

- A. Operation and Maintenance Data: For meters and gages to include in operation and maintenance manuals.

## PART 2 - PRODUCTS

## 2.1 LIQUID-IN-GLASS THERMOMETERS

- A. Metal-Case, Industrial-Style, Liquid-in-Glass Thermometers:
  - 1. Manufacturers: Subject to compliance with requirements, provide products by one of the following:

- a. Palmer Wahl Instrumentation Group.
  - b. Trerice, H. O. Co.
  - c. Weiss Instruments, Inc.
  - d. Weksler.
2. Standard: ASME B40.200.
  3. Case: Die Cast aluminum or brass; nominal size unless otherwise indicated.
  4. Case Form: Adjustable angle type unless otherwise indicated, 180 degrees in vertical plane, 360 degrees in horizontal plane, with locking device.
  5. Tube: Glass with magnifying lens and blue organic liquid.
  6. Tube Background: Satin faced, nonreflective aluminum with permanently etched scale markings graduated in deg F.
  7. Window: Glass.
  8. Stem: Copper-plated steel, aluminum, stainless steel, or brass designed for thermowell installation. Stem shall be of length to match thermowell insertion length.
    - a. Design for Thermowell Installation: Bare stem.
  9. Connector: 1-1/4 inches, with ASME B1.1 screw threads.
  10. Accuracy: Plus or minus 1 percent of scale range or one scale division, to a maximum of 1.5 percent of scale range.

## 2.2 THERMOWELLS

### A. Thermowells:

1. Manufacturers: Subject to compliance with requirements, provide products by one of the following:
  - a. AMETEK, Inc.; U.S. Gauge Div.
  - b. Ashcroft Commercial Instrument Operations; Dresser Industries; Instrument Div.
  - c. Ernst Gage Co.
  - d. Marsh Bellofram.
  - e. Miljoco Corp.
  - f. NANMAC Corporation.
  - g. Noshok, Inc.
  - h. Palmer - Wahl Instruments Inc.
  - i. REO TEMP Instrument Corporation.
  - j. Tel-Tru Manufacturing Company.
  - k. Trerice, H. O. Co.
  - l. Weiss Instruments, Inc.
  - m. Weksler
  - n. WIKA Instrument Corporation.
  - o. Winters Instruments.
2. Manufacturers: Same as manufacturer of thermometer being used.
3. Standard: ASME B40.200.
4. Description: Pressure-tight, socket-type fitting made for insertion into piping tee fitting.
5. Material for Use with Copper Tubing: Brass.



6. Material for Use with Steel Piping: Brass.
7. Type: Stepped shank unless straight or tapered shank is indicated.
8. External Threads: NPS 1/2, NPS 3/4, NPS 1 or NPS 1-1/4 ASME B1.20.1 pipe threads.
9. Internal Threads: 1/2, 3/4, and 1 inch with ASME B1.1 screw threads.
10. Bore: Diameter required to match thermometer bulb or stem.
11. Insertion Length: Length required to match thermometer bulb or stem.
12. Lagging Extension: Include on thermowells for insulated piping and tubing.
13. Bushings: For converting size of thermowell's internal screw thread to size of thermometer connection.

- B. Heat-Transfer Medium: Mixture of graphite and glycerin.

## 2.3 PRESSURE GAGES

- A. Direct-Mounted, Metal-Case, Dial-Type Pressure Gages:

1. Manufacturers: Subject to compliance with requirements, provide products by one of the following:
  - a. AMETEK, Inc.; U.S. Gauge.
  - b. Ashcroft Inc.
  - c. Ernst Flow Industries.
  - d. KOBOLD Instruments, Inc.
  - e. Marsh Bellofram.
  - f. Miljoco Corporation.
  - g. Noshok.
  - h. Palmer Wahl Instrumentation Group.
  - i. REOTEMP Instrument Corporation.
  - j. Trerice, H. O. Co.
  - k. Weiss Instruments, Inc.
  - l. Weksler
  - m. WIKA Instrument Corporation.
  - n. Winters Instruments - U.S.
2. Standard: ASME B40.100.
3. Case: Liquid-filled type; cast aluminum or drawn steel; 4-1/2-inch nominal diameter.
4. Pressure-Element Assembly: Bourdon tube unless otherwise indicated.
5. Pressure Connection: Brass, with ASME B1.20.1 pipe threads and bottom-outlet type unless back-outlet type is indicated. NPS 1/4 or NPS 1/2.
6. Movement: Mechanical, with link to pressure element and connection to pointer.
7. Dial: Satin faced, nonreflective aluminum with permanently etched scale markings graduated in psi .
8. Pointer: Dark-colored metal.
9. Window: Glass.
10. Ring: Stainless steel.
11. Accuracy: Grade A, plus or minus 1 percent of middle half of scale range.

- B. Remote-Mounted, Metal-Case, Dial-Type Pressure Gages:

1. Manufacturers: Subject to compliance with requirements, provide products by one of the following:

- a. AMETEK, Inc.; U.S. Gauge.
  - b. Ashcroft Inc.
  - c. Ernst Flow Industries.
  - d. KOBOLD Instruments, Inc.
  - e. Marsh Bellofram.
  - f. Miljoco Corporation.
  - g. Noshok.
  - h. Palmer Wahl Instrumentation Group.
  - i. REOTEMP Instrument Corporation.
  - j. Trerice, H. O. Co.
  - k. Weiss Instruments, Inc.
  - l. Weksler
  - m. WIKA Instrument Corporation.
  - n. Winters Instruments - U.S.
2. Standard: ASME B40.100.
  3. Case: Liquid-filled, cast aluminum or drawn steel; diameter with back flange for panel surface mounting or front flange for panel recessed mounting. Flanges to include pre-drilled screw holes.
  4. Pressure-Element Assembly: Bourdon tube unless otherwise indicated.
  5. Pressure Connection: Brass, with ASME B1.20.1 pipe threads and bottom-outlet type unless back-outlet type is indicated. NPS 1/4 or NPS 1/2.
  6. Movement: Mechanical, with link to pressure element and connection to pointer.
  7. Dial: Satin faced, nonreflective aluminum with permanently etched scale markings graduated in psi .
  8. Pointer: Dark-colored metal.
  9. Window: Glass.
  10. Ring: Stainless steel.
  11. Accuracy: Grade A, plus or minus 1 percent of middle half of scale range.

#### 2.4 GAGE ATTACHMENTS

- A. Snubbers: ASME B40.100, brass; with ASME B1.20.1 pipe threads. Include extension for use on insulated piping. NPS 1/4 or NPS 1/2 .
  1. Surge-dampening device: porous-metal-type.
- B. Siphons:
  1. Loop-shaped section: Brass pipe with pipe threads. NPS 1/4 or NPS 1/2.
- C. Valves:
  1. Needle: Brass, with NPS 1/4 or NPS 1/2 ASME B1.20.1 pipe threads.

#### 2.5 TEST PLUGS

- A. Manufacturers: Subject to compliance with requirements, provide products by one of the following:
  1. Flow Design, Inc.
  2. MG Piping Products Co.
  3. National Meter, Inc.
  4. Peterson Equipment Co., Inc.

5. Sisco Manufacturing Company, Inc.
6. Trerice, H. O. Co.
7. Twin City Hose.
8. Watts Regulator Co.; a div. of Watts Water Technologies, Inc.
9. Welsler.

- B. Description: Test-station fitting made for insertion into piping tee fitting.
- C. Body: Brass or stainless steel with core inserts and gasketed and threaded cap. Include extended stem on units to be installed in insulated piping.
- D. Thread Size: or , ASME B1.20.1 pipe thread.
- E. Minimum Pressure and Temperature Rating:
- F. Core Inserts: Self-sealing synthetic rubber;
1. EPDM (Nordel) for air, water or glycol operation between 30 and 275 deg F.
  2. CR (Neoprene) for air, water, glycol, oil, or gas operation between -30 to 200 deg F.

## 2.6 TEST-PLUG KITS

- A. Manufacturers: Subject to compliance with requirements, provide products by one of the following:
1. Flow Design, Inc.
  2. MG Piping Products Co.
  3. National Meter, Inc.
  4. Peterson Equipment Co., Inc.
  5. Sisco Manufacturing Company, Inc.
  6. Trerice, H. O. Co.
  7. Watts Regulator Co.; a div. of Watts Water Technologies, Inc.
  8. Weiss Instruments, Inc.
- B. Furnish the number of test-plug kits given below with the number of thermometers given below, with each kit having one pressure gage and adapter, and carrying case. Thermometer sensing elements, pressure gage, and adapter probes shall be of diameter to fit test plugs and of length to project into piping.
1. Low-Range Thermometer: Small, bimetallic insertion type with 1- to 2-inch diameter dial and tapered-end sensing element. Dial range shall be at least 25 to 125 deg F .
  2. High-Range Thermometer: Small, bimetallic insertion type with 1- to 2-inch diameter dial and tapered-end sensing element. Dial range shall be at least 0 to 220 deg F .
  3. Pressure Gage: Small, Bourdon-tube insertion type with 2- to 3-inch diameter dial and probe. Dial range shall be at least to 200 psig.
  4. Carrying Case: Metal or plastic, with formed instrument padding.
  5. One test-plug kit with:
    - a. Two thermometers.

## 2.7 FLOWMETERS

## A. Orifice Flowmeters:

1. Manufacturers: Subject to compliance with requirements, provide products by one of the following:
  - a. ABB; Instrumentation and Analytical.
  - b. Armstrong Pumps Inc.; S. A. Armstrong Limited.
  - c. Badger Meter, Inc.; Industrial Div.
  - d. Bell & Gossett; ITT Industries.
  - e. Meriam Process Technologies.
  - f. Spirax Sarco
2. Description: Flowmeter with sensor, hoses or tubing, quick connect hose fittings, valves, indicator, and conversion chart.
3. Flow Range: Sensor and indicator shall cover operating range of equipment or system served.
4. Sensor: Wafer-orifice-type, calibrated, flow-measuring element; for installation between pipe flanges.
  - a. Design: Differential-pressure-type measurement:
    - 1) For HVAC hot and chilled water.
  - b. Construction: Cast-iron body, brass valves with integral check valves and caps, and calibrated nameplate.
  - c. Minimum Pressure Rating: 300 psig.
  - d. Minimum Temperature Rating: 250 deg F.
  - e. .
5. Portable Indicators: Hand-held, differential-pressure type, calibrated for connected sensor and having two 12-foot hoses, with carrying case.
  - a. Scale: Gallons per minute.
  - b. Accuracy: Plus or minus 2 percent between 20 and 80 percent of scale range.
6. Conversion Chart: Flow rate data compatible with sensor and indicator.
7. Operating Instructions: Include complete instructions with each flowmeter.

## B. Venturi Flowmeters:

1. Manufacturers: Subject to compliance with requirements, provide products by one of the following:
  - a. Armstrong Pump
  - b. Badger Meter, Inc.; Industrial Division
  - c. Bailey-Fischer & Porter Co.
  - d. Flow Design, Inc.
  - e. Gerand Engineering Co.
  - f. Hyspan Precision Products, Inc.
  - g. Leeds & Northrup.
  - h. McCrometer, Inc.
  - i. Preso Meters; a division of Racine Federated Inc.
  - j. Victaulic Company.

- k. Spirax Sarco
- 2. Description: Flowmeter with calibrated flow-measuring element, hoses or tubing, quick connect hose fittings, valves, indicator, and conversion chart.
- 3. Flow Range: Sensor and indicator shall cover operating range of equipment or system served.
- 4. Sensor: Venturi-type, calibrated, flow-measuring element; for installation in piping.
  - a. Design: Differential-pressure-type measurement for water.
  - b. Construction: Bronze, brass, or factory-primed steel, with brass fittings and attached tag with flow conversion data.
  - c. Minimum Pressure Rating: 250 psig .
  - d. Minimum Temperature Rating: 250 deg F .
  - e. End Connections for NPS 2 and Smaller: Threaded.
  - f. End Connections for NPS 2-1/2 and Larger: Flanged or welded.
  - g. Flow Range: Flow-measuring element and flowmeter shall cover operating range of equipment or system served.

### PART 3 - EXECUTION

#### 3.1 INSTALLATION

- A. Install thermowells: with socket extending one-third of pipe diameter and in vertical position in piping tees.
- B. Install thermowells of sizes required to match thermometer connectors. Include bushings if required to match sizes.
- C. Install thermowells with extension on insulated piping.
- D. Fill thermowells with heat-transfer medium.
- E. Install direct-mounted thermometers in thermowells and adjust vertical and tilted positions to most readable position.
- F. Install direct-mounted pressure gages in piping tees with pressure gage located on pipe at the most readable position.
- G. Install needle-valve and snubber in piping for each pressure gage for fluids. Exception: Steam.
- H. Install test plugs in piping tees.
- I. Install thermometers in the following locations:
  - 1. Inlet and outlet of each hydronic boiler.
  - 2. Two inlets and two outlets of each chiller.
  - 3. Inlet and outlet of each hydronic coil in air-handling units.
  - 4. Two inlets and two outlets of each hydronic heat exchanger.
  - 5. Inlet and outlet of each thermal-storage tank.

6. Inlet and outlet of each piece of steam equipment.

J. Install pressure gages in the following locations:

1. Inlet and discharge of each pressure-reducing valve.
2. Inlet and outlet of each chiller chilled-water and condenser-water connection.
3. Suction and discharge of each pump.

### 3.2 CONNECTIONS

A. Install meters and gages adjacent to machines and equipment to allow service and maintenance of meters, gages, machines, and equipment.

### 3.3 ADJUSTING

A. Adjust faces of meters and gages to proper angle for best visibility.

### 3.4 THERMOMETER SCHEDULE

A. Thermometers at inlet and outlet of each hydronic zone shall be one of the following:

1. Test plug: With EPDM self-sealing rubber inserts.

B. Thermometers at inlet and outlet of each hydronic coil in air-handling units and built-up central systems shall be one of the following:

1. Industrial-style, liquid-in-glass type.

C. Thermometers at inlet and outlet of each hydronic coil at fan coils, cabinet heaters, unit heaters and reheat coils and as shown on details shall be the following:

1. Industrial-style, liquid-in-glass type.
2. Test plug with CR self-sealing rubber inserts.
3. Test plug with EPDM self-sealing rubber inserts.

D. Thermometers at inlets and outlets of each hydronic heat exchanger shall be the one of following:

1. Industrial-style, liquid-in-glass type.

E. Thermometer stems shall be of length to match thermowell insertion length.

### 3.5 THERMOMETER SCALE-RANGE SCHEDULE

A. Scale Range for Chilled-Water Piping: 0 to 100 deg F.

B. Scale Range for Heating, Hot-Water Piping: 30 to 240 deg F.

C. Scale Range for Air Ducts: Minus 40 to plus 110 deg F.

## 3.6 PRESSURE-GAGE SCHEDULE

- A. Pressure gages at inlet and discharge of each pressure-reducing valve shall be the one of following:
  - 1. Dry-case type, direct-mounted, metal case.
- B. Pressure gages at inlet and outlet of each chiller chilled-water and condenser-water connection shall be one of the following:
  - 1. Liquid-filled, direct-mounted, metal case.
- C. Pressure gages at suction and discharge of each pump shall be one of the following:
  - 1. Liquid-filled, direct-mounted, metal case.

## 3.7 PRESSURE-GAGE SCALE-RANGE SCHEDULE

- A. Scale Range for Chilled-Water, Condenser-Water, Heating, Hot-Water, Steam and Condensate Piping shall be twice the normal operating pressure of the measured system with gage ranges as follows:
  - 1. 30 in. Hg to 15 psi.
  - 2. 0 to 30 psi.
  - 3. 0 to 100 psi.
  - 4. 0 to 160 psi.
  - 5. 0 to 200 psi.
  - 6. 0 to 300 psi.
  - 7. 0 to 600 psi.

## 3.8 FLOWMETER SCHEDULE

- A. Flowmeters for Heating, Hot-Water Piping: Venturi type.

END OF SECTION

**SECTION 23 05 23 - GENERAL-DUTY VALVES FOR HVAC PIPING**

PART 1 - GENERAL

1.1 RELATED DOCUMENTS

- A. Drawings and general provisions of the Contract, including General and Supplementary Conditions and Division 01 Specification Sections, apply to this Section.

1.2 SUMMARY

- A. Section Includes:

- 1. Bronze ball valves.
- 2. Iron, single-flange butterfly valves.
- 3. Bronze lift check valves.
- 4. Bronze swing check valves.
- 5. Iron swing check valves.
- 8. Bronze globe valves.
- 9. Iron globe valves.
- 10. Lubricated plug valves.

- B. Related Sections:

- 1. Section 230553 "Identification for HVAC Piping and Equipment" for valve tags and schedules.

1.3 DEFINITIONS

- A. CWP: Cold working pressure.
- B. EPDM: Ethylene propylene copolymer rubber.
- C. NBR: Acrylonitrile-butadiene, Buna-N, or nitrile rubber.
- D. NRS: Nonrising stem.
- E. OS&Y: Outside screw and yoke.
- F. RS: Rising stem.
- G. SWP: Steam working pressure.



## 1.4 ACTION SUBMITTALS

- A. Product Data: For each type of valve indicated. Body material, valve design, pressure and temperature classification, end connection details, seating materials, trim material and arrangement, dimensions and required clearances, and installation instructions. Include list indicating valve and its application.
- B. Maintenance data for valves to be included in the operation and maintenance data specified in Division 1. Include detailed manufacturer's instructions on adjusting, servicing, disassembling, and repairing.

## 1.5 QUALITY ASSURANCE

- A. Source Limitations for Valves: Obtain each type of valve as listed in SUMMARY from a single source and from a single manufacturer.
- B. Compliance:
  - 1. ASME B16.10 and ASME B16.34 for ferrous valve dimensions and design criteria.
  - 2. ASME B31.1 for power piping valves.
  - 3. ASME B31.9 for building services piping valves.
  - 4. MSS Compliance: Comply with the various MSS Standard Practice documents referenced.

## 1.6 DELIVERY, STORAGE, AND HANDLING

- A. Prepare valves for shipping as follows:
  - 1. Protect internal parts against rust and corrosion.
  - 2. Protect threads, flange faces, and weld ends.
  - 3. Set angle, and globe valves closed to prevent rattling.
  - 4. Set ball and plug valves open to minimize exposure of functional surfaces.
  - 5. Set butterfly valves closed or slightly open.
  - 6. Block check valves in either closed or open position.
- B. Use the following precautions during storage:
  - 1. Maintain valve end protection.
  - 2. Store valves indoors and maintain at higher than ambient dew point temperature. If outdoor storage is necessary, store valves off the ground in watertight enclosures.
- C. Use sling to handle large valves; rig sling to avoid damage to exposed parts. Do not use handwheels or stems as lifting or rigging points.

## PART 2 - PRODUCTS

## 2.1 GENERAL REQUIREMENTS FOR VALVES

- A. Refer to HVAC valve schedule articles for applications of valves.
- B. Valve Pressure and Temperature Ratings: Not less than indicated and as required for system pressures and temperatures.
- C. Valve Sizes: Same as upstream piping unless otherwise indicated.
- D. Valve Actuator Types:
  - 1. Gear Actuator: For quarter-turn valves NPS 8 and larger.
  - 2. Handwheel: For valves other than quarter-turn types.
  - 3. Handlever: For quarter-turn valves NPS 6 and smaller.
  - 4. Wrench: For plug valves with square heads. Furnish Owner with 1 wrench for every 5 plug valves, for each size square plug-valve head.
- E. Valves in Insulated Piping: With 2-inch stem extensions and the following features:
  - 2. Ball Valves: With extended operating handle of non-thermal-conductive material, and protective sleeve that allows operation of valve without breaking the vapor seal or disturbing insulation.
  - 3. Butterfly Valves: With extended neck.
- F. Valve-End Connections:
  - 1. Flanged: With flanges according to ASME B16.1 for iron valves.
  - 2. Solder Joint: With sockets according to ASME B16.18.
    - a. Caution: Where soldered end connections are used, use solder having a melting point below 840 deg. For, globe, and check valves: below 421 deg. F for ball valves.
  - 3. Threaded: With threads according to ASME B1.20.1.
- G. Valve Bypass and Drain Connections: MSS SP-45.

## 2.2 MANUFACTURERS

- A. Subject to compliance with requirements, provide products by one of the following:
  - 1. APCO Willamette Valve and Primer Corp.
  - 2. Babbitt Steam Specialty Company.
  - 3. Bray Controls.
  - 4. Center Line.
  - 5. Cla-Val Company.
  - 6. Conbraco Industries Inc.
  - 7. Crane Co.; Crane Valve Group.
  - 8. Fisher Valve by Emerson.
  - 9. Flo Fab Inc.

10. Flow-Tek Inc.
11. Grinnell Corporation.
12. Hammond Valve.
13. Jamesbury; a subsidiary of Metso Automation.
14. Jomar International LTD.
15. Keystone Valve USA, Inc.
16. Kitz Corp.
17. Legend Valve.
18. Metraflex Company.
19. Milwaukee Valve Company.
20. Mueller Steam Specialty.
21. NIBCO Inc.
22. Red-White Valve Corp.
23. Spence Strainers International.
24. Stockham Valves and Fittings, Inc.
25. Tyco Fire/Shurjoint Piping Products.
26. Tyco/Pentair LTD.
27. Val-Matic Valve & Mfg. Corp.
28. Victaulic Company.
29. Watts Regulator Company.

## 2.4 BRONZE BALL VALVES

### C. Two-Piece, Full-Port, Bronze Ball Valves with Bronze Trim:

1. Description:
  - a. Standard: MSS SP-110.
  - b. SWP Rating: 150 psig.
  - c. CWP Rating: 600 psig.
  - d. Body Design: Two piece.
  - e. Body Material: Bronze.
  - f. Ends: Threaded.
  - g. Seats: PTFE or TFE.
  - h. Stem: Bronze.
  - i. Ball: Chrome-plated brass.
  - j. Port: Full.

## 2.5 IRON, SINGLE-FLANGE BUTTERFLY VALVES

### A. 150 CWP, Iron, Single-Flange (Lug) Butterfly Valves:

1. Description:
  - a. Standard: MSS SP-67, Type I.
  - b. CWP Rating: 150 psig.
  - c. Body Design: Lug type; suitable for bidirectional dead-end service at rated pressure without use of downstream flange.
  - d. Body Material: ASTM A 126, cast iron or ASTM A 536, ductile iron.
  - e. Seat: EPDM.
  - f. Stem: One- or two-piece stainless steel.

- g. Disc: Nylon 11 coated ductile iron.
- B. 175 CWP, Iron, Single-Flange (Lug) Butterfly Valves:
- 1. Description:
    - a. Standard: MSS SP-67, Type I.
    - b. CWP Rating: 175 psig.
    - c. Body Design: Lug type; suitable for bidirectional dead-end service at rated pressure without use of downstream flange.
    - d. Body Material: ASTM A 126, cast iron or ASTM A 536, ductile iron.
    - e. Seat: EPDM.
    - f. Stem: One- or two-piece stainless steel.
    - g. Disc: Nylon 11 coated ductile iron.
- C. 200 CWP, Iron, Single-Flange Butterfly Valves with EPDM Seat and Nylon 11 coated ductile Iron Disc:
- 1. Description:
    - a. Standard: MSS SP-67, Type I.
    - b. CWP Rating: 200 psig.
    - c. Body Design: Lug type; suitable for bidirectional dead-end service at rated pressure without use of downstream flange.
    - d. Body Material: ASTM A 126, cast iron or ASTM A 536, ductile iron.
    - e. Seat: EPDM.
    - f. Stem: One- or two-piece stainless steel.
    - g. Disc: Nylon 11 coated ductile iron.
- D. 250 CWP, Iron, Single-Flange Butterfly Valves with EPDM Seat and Nylon 11 coated ductile Iron Disc:
- 1. Description:
    - a. Standard: MSS SP-67, Type I.
    - b. CWP Rating: 250 psig.
    - c. Body Design: Lug type; suitable for bidirectional dead-end service at rated pressure without use of downstream flange.
    - d. Body Material: ASTM A 126, cast iron or ASTM A 536, ductile iron.
    - e. Seat: EPDM.
    - f. Stem: One- or two-piece stainless steel.
    - g. Disc: Nylon 11 coated ductile iron.

## 2.6 BRONZE LIFT CHECK VALVES

- A. Class 125, Lift Check Valve:
- 1. Description:
    - a. Standard: MSS SP-80.
    - b. CWP Rating: 200 psig.
    - c. Body Design: Vertical flow.
    - d. Body Material: ASTM B 61, ASTM B 62, bronze.

- e. Ends: Threaded.
- f. Disc: Bronze, Type 1.

## 2.7 BRONZE SWING CHECK VALVES

### A. Class 150, Bronze Swing Check Valves with Bronze Disc:

#### 1. Description:

- a. Standard: MSS SP-80, Type 3.
- b. CWP Rating: 300 psig.
- c. Body Design: Horizontal flow.
- d. Body Material: ASTM B 62, bronze.
- e. Ends: Threaded.
- f. Disc: Bronze.

## 2.8 IRON SWING CHECK VALVES

### A. Class 125, Iron Swing Check Valves with Metal Seats:

#### 1. Description:

- a. Standard: MSS SP-71, Type I.
- b. NPS 2-1/2 to NPS 12, CWP Rating: 200 psig.
- c. Body Design: Clear or full waterway.
- d. Body Material: ASTM A 126, gray iron with bolted bonnet.
- e. Ends: Flanged.
- f. Trim: Bronze.
- g. Gasket: Asbestos free.

## 2.9 BRONZE GLOBE VALVES

### A. Class 150, Bronze Globe Valves with Nonmetallic Disc:

#### 1. Description:

- a. Standard: MSS SP-80, Type 2.
- b. CWP Rating: 300 psig.
- c. Body Material: ASTM B 62, bronze with integral seat and union-ring bonnet.
- d. Ends: Threaded.
- e. Stem: Bronze.
- f. Disc: PTFE or TFE.
- g. Packing: Teflon impregnated, asbestos free.
- h. Handwheel: Malleable iron.

## 2.10 IRON GLOBE VALVES

### A. Class 125, Iron Globe Valves:

1. Description:
  - a. Standard: MSS SP-85, Type I.
  - b. CWP Rating: 200 psig.
  - c. Body Material: ASTM A 126, gray iron with bolted bonnet.
  - d. Ends: Flanged.
  - e. Stem: Brass alloy. OS &Y.
  - f. Disc: Renewable bronze seat.
  - g. Trim: Bronze.
  - h. Packing and Gasket: Teflon impregnated, asbestos free.
  - i. Handwheel: Cast iron

## 2.11 LUBRICATED PLUG VALVES

- A. Class 125, Regular-Gland, Lubricated Plug Valves with Threaded Ends:

1. Description:
  - a. Standard: MSS SP-78, Type II.
  - b. NPS 2-1/2 to NPS 12, CWP Rating: 200 psig.
  - c. Pattern: Regular or short.
  - d. Body Material: ASTM A 48 or ASTM A 126, cast iron with lubrication-sealing system.
  - e. Plug: Cast iron or bronze with sealant groove.

## PART 3 - EXECUTION

### 3.1 EXAMINATION

- A. Examine piping system for compliance with requirements for installation tolerances and other conditions affecting performance of valves. Do not proceed with installation until unsatisfactory conditions have been corrected.
- B. Examine valve interior for cleanliness, freedom from foreign matter, and corrosion. Remove special packing materials, such as blocks, used to prevent disc movement during shipping and handling.
- C. Operate valves in positions from fully open to fully closed. Examine guides and seats made accessible by such operations.
- D. Examine threads on valve and mating pipe for form and cleanliness.
- E. Examine mating flange faces for conditions that might cause leakage. Check bolting for proper size, length, and material. Verify that gasket is of proper size, that its material composition is suitable for service, and that it is free from defects and damage.
- F. Do not attempt to repair defective valves; replace with new valves.

### 3.2 VALVE INSTALLATION

- A. Install valves as indicated, according to manufacturer's written instructions.
- B. Piping installation requirements are specified in other Division 23 Sections. Drawings indicate the general arrangement of piping, fittings, and specialties.
- C. Install valves with unions or flanges at each piece of equipment arranged to allow service, maintenance, and equipment removal without system shutdown.
- D. Locate valves for easy access and provide separate support where necessary.
- E. Install valves in horizontal piping with stem at or above center of pipe.
- F. Install valves in position to allow full stem movement.
- G. Install check valves for proper direction of flow and as follows:
  - 1. Swing Check Valves: In horizontal position with hinge pin level.
  - 2. Check Valves: In horizontal or vertical position, between flanges.
  - 3. Lift Check Valves: With stem upright and plumb.
  - 4. Install all check valves a minimum of five pipe diameters downstream of pump discharge or elbow to avoid flow turbulence. In extreme cases add flow straighteners as required to correct the turbulence.

### 3.3 ADJUSTING

- A. Adjust or replace valve packing after piping systems have been tested and put into service but before final adjusting and balancing. Replace valves if persistent leaking occurs.

### 3.4 GENERAL REQUIREMENTS FOR VALVE APPLICATIONS

- A. If valve applications are not indicated, use the following:
  - 1. Shutoff Service: Ball or butterfly valves.
  - 2. Butterfly Valve Dead-End Service: Single-flange (lug) type.
  - 3. Throttling Service except Steam: Globe valves.
  - 4. Throttling Service, Steam: Globe valves.
  - 5. Pump-Discharge Check Valves:
    - a. NPS 2 and Smaller: Bronze swing check valves with bronze disc.
    - b. NPS 2-1/2 and Larger: Iron swing check valves with lever and weight or with spring or iron, metal-seat check valves.
  - 6. Drain Service (except Steam): Two-Piece, Full Port Bronze Ball Valves with Bronze Trim. To be installed with NPS 3/4 hose thread outlet and hose cap with chain.
- B. If valves with specified SWP classes or CWP ratings are not available, the same types of valves with higher SWP classes or CWP ratings may be substituted.

- C. Select valves, except wafer types, with the following end connections:
1. For Copper Tubing, NPS 2 and Smaller: Threaded ends except where solder-joint valve-end option is indicated in valve schedules below.
  2. For Copper Tubing, NPS 2-1/2 to NPS 4: Flanged ends except where threaded valve-end option is indicated in valve schedules below.
  3. For Copper Tubing, NPS 5 and Larger: Flanged ends.
  4. For Steel Piping, NPS 2 and Smaller: Threaded ends.
  5. For Steel Piping, NPS 2-1/2 to NPS 4: Flanged ends except where threaded valve-end option is indicated in valve schedules below.
  6. For Steel Piping, NPS 5 and Larger: Flanged ends.

### 3.5 CHILLED-WATER VALVE SCHEDULE

- A. Pipe NPS 2 and Smaller:
1. Bronze Valves: May be provided with solder-joint ends instead of threaded ends.
  3. Ball Valves:
    - a. Piece: Two
    - b. Port: Full.
    - c. Material/Trim: Bronze with:
      - 1) Bronze trim.
  4. Bronze Swing Check Valves:
    - a. Class 150
    - b. Bronze disc.
  6. Bronze Globe Valves:
    - a. Class 125
    - b. Bronze disc.
- B. Pipe NPS 2-1/2 and Larger:
1. Iron Valves, NPS 2-1/2 to NPS 4: May be provided with threaded ends instead of flanged ends.
  2. Iron, Single-Flange Butterfly Valves, NPS 2-1/2 to NPS 12:
    - a. 200 CWP,
    - b. Seat: EPDM.
    - c. Disc: Ductile-iron.
  3. Iron Swing Check Valves: Class 125, metal seats.
  4. Iron Globe Valves: Class 125.
  5. Lubricated Plug Valves: Class 125, regular gland, flanged.

### 3.6 HEATING-WATER VALVE SCHEDULE

- A. Pipe NPS 2 and Smaller:
1. Bronze Valves: May be provided with solder-joint ends instead of threaded ends.
  3. Ball Valves:
    - a. Piece: Two
    - b. Port: Full.
    - c. Material/Trim: Bronze with:
      - 1) Bronze trim.



4. Bronze Swing Check Valves:
    - a. Class 150
    - b. Bronze disc.
  6. Bronze Globe Valves:
    - a. Class 125
    - b. Bronze disc.
- B. Pipe NPS 2-1/2 and Larger:
1. Iron Valves, NPS 2-1/2 to NPS 4: May be provided with threaded ends instead of flanged ends.
  2. Iron, Single-Flange Butterfly Valves, NPS 2-1/2 to NPS 12:
    - a. 200 CWP,
    - b. Seat: EPDM.
    - c. Disc: Ductile-iron.
  3. Iron Swing Check Valves: Class 125, metal seats.
  4. Iron Globe Valves: Class 125.

END OF SECTION

**SECTION 23 05 29 - HANGERS AND SUPPORTS FOR HVAC PIPING AND EQUIPMENT**

## PART 1 - GENERAL

## 1.1 RELATED DOCUMENTS

- A. Drawings and general provisions of the Contract, including General and Supplementary Conditions and Division 01 Specification Sections, apply to this Section.

## 1.2 SUMMARY

## A. Section Includes:

1. Metal pipe hangers and supports.
2. Trapeze pipe hangers.
3. Metal framing systems.

## B. Related Sections:

1. Division 05 for structural-steel shapes and plates for trapeze hangers for pipe and equipment supports.
2. Section 230516 "Expansion Fittings and Loops for HVAC Piping" for pipe guides and anchors.
3. Section 230548 "Vibration and Seismic Controls for HVAC" for vibration isolation devices.
4. Section 233113 "Metal Ducts" for duct hangers and supports.

## 1.3 DEFINITIONS

- A. MSS: Manufacturers Standardization Society of The Valve and Fittings Industry Inc.

## 1.4 PERFORMANCE REQUIREMENTS

- A. Structural Performance: Hangers and supports for HVAC piping and equipment shall withstand the effects of gravity loads and stresses within limits and under conditions indicated according to ASCE/SEI 7.
  1. Design supports for multiple pipes, including pipe stands, capable of supporting combined weight of supported systems, system contents, and test water.
  2. Design equipment supports capable of supporting combined operating weight of supported equipment and connected systems and components.

## 1.5 ACTION SUBMITTALS

- A. Product Data: For each type of product indicated.

- B. Shop Drawings: Signed and sealed by a qualified professional engineer. Show fabrication and installation details and include calculations for the following; include Product Data for components:
  - 1. Trapeze pipe hangers.
  - 2. Metal framing systems.

#### 1.6 INFORMATIONAL SUBMITTALS

- A. Welding certificates.

### PART 2 - PRODUCTS

#### 2.1 METAL PIPE HANGERS AND SUPPORTS

- A. Carbon-Steel Pipe Hangers and Supports:
  - 1. Description: MSS SP-58, Types 1 through 58, factory-fabricated components.
  - 2. Galvanized Metallic Coatings: Pregalvanized or hot dipped.
  - 3. Nonmetallic Coatings: Plastic coating, jacket, or liner.
  - 4. Padded Hangers: Hanger with fiberglass or other pipe insulation pad or cushion to support bearing surface of piping.
  - 5. Hanger Rods: Continuous-thread rod, nuts, and washer made of carbon steel.

#### 2.2 TRAPEZE PIPE HANGERS

- A. Description: MSS SP-69, Type 59, shop- or field-fabricated pipe-support assembly made from structural carbon-steel shapes with MSS SP-58 carbon-steel hanger rods, nuts, saddles, and U-bolts.

#### 2.3 METAL FRAMING SYSTEMS

- A. MFMA Manufacturer Metal Framing Systems:
  - 1. Manufacturers: Subject to compliance with requirements, provide products by one of the following:
    - a. Anvil International.
    - b. Cooper B-Line, Inc.; a division of Cooper Industries.
    - c. ERICO/Michigan Hanger Co. ; ERISTRUT Div.
    - d. FNW/Ferguson Enterprises
    - e. GS Metals Corp.
    - f. Hilti, Inc.insert manufacturer's name.
    - g. Power-Strut Div. Tyco International.
    - h. Thomas & Betts Corporation.
    - i. Tolco Inc.
    - j. Unistrut; an Atkore International company.

2. Description: Shop- or field-fabricated pipe-support assembly for supporting multiple parallel pipes.
3. Standard: MFMA-4.
4. Channels: Continuous slotted steel channel with inturned lips.
5. Channel Nuts: Formed or stamped steel nuts or other devices designed to fit into channel slot and, when tightened, prevent slipping along channel.
6. Hanger Rods: Continuous-thread rod, nuts, and washer made of carbon steel.
7. Metallic Coating:
  - a. Electroplated zinc.

B. Non-MFMA Manufacturer Metal Framing Systems:

1. Manufacturers: Subject to compliance with requirements, provide products by one of the following:
  - a. Anvil International; a subsidiary of Mueller Water Products, Inc.
  - b. Empire Industries, Inc.
  - c. ERICO International Corporation.
  - d. FNW/Ferguson Enterprises
  - e. Haydon Corporation.
  - f. NIBCO INC.
  - g. PHD Manufacturing, Inc.
  - h. PHS Industries, Inc.
2. Description: Shop- or field-fabricated pipe-support assembly made of steel channels, accessories, fittings, and other components for supporting multiple parallel pipes.
3. Standard: Comply with MFMA-4.
4. Channels: Continuous slotted steel channel with inturned lips.
5. Channel Nuts: Formed or stamped steel nuts or other devices designed to fit into channel slot and, when tightened, prevent slipping along channel.
6. Hanger Rods: Continuous-thread rod, nuts, and washer made of carbon steel.
7. Coating:
  - a. Zinc.

2.4 THERMAL-HANGER SHIELD INSERTS

- A. Manufacturers: Subject to compliance with requirements, provide products by one of the following:
1. Carpenter & Paterson, Inc.
  2. Clement Support Services.
  3. ERICO International Corporation.
  4. National Pipe Hanger Corporation.
  5. PHS Industries, Inc.
  6. Pipe Shields Inc.
  7. Piping Technology & Products, Inc.
  8. Rilco Manufacturing Co., Inc.
  9. Value Engineered Products, Inc.

- B. Insulation-Insert Material for Cold Piping:
  - 1. Water-repellent treated, ASTM C 533, Type I calcium silicate with 100-psig minimum compressive strength.
- C. Insulation-Insert Material for Hot Piping:
  - 1. Water-repellent treated, ASTM C 533, Type I calcium silicate with 100-psig minimum compressive strength.
- D. For Trapeze or Clamped Systems: Insert and shield shall cover entire circumference of pipe.
- E. For Clevis or Band Hangers: Insert and shield shall cover lower 180 degrees of pipe.
- F. Insert Length: Extend 2 inches beyond sheet metal shield for piping operating below ambient air temperature.

## 2.5 FASTENER SYSTEMS

- A. Powder-Actuated Fasteners: Threaded-steel stud, for use in hardened portland cement concrete with pull-out, tension, and shear capacities appropriate for supported loads and building materials where used.
- B. Mechanical-Expansion Anchors: Insert-wedge-type, [zinc-coated] [stainless-] steel anchors, for use in hardened portland cement concrete; with pull-out, tension, and shear capacities appropriate for supported loads and building materials where used.

## 2.6 MISCELLANEOUS MATERIALS

- A. Structural Steel: ASTM A 36, carbon-steel plates, shapes, and bars; black and galvanized.
- B. Grout: ASTM C 1107, factory-mixed and -packaged, dry, hydraulic-cement, nonshrink and nonmetallic grout; suitable for interior and exterior applications.
  - 1. Properties: Nonstaining, noncorrosive, and nongaseous.
  - 2. Design Mix: 5000-psi, 28-day compressive strength.

## PART 3 - EXECUTION

### 3.1 HANGER AND SUPPORT INSTALLATION

- A. Comply with SEI/ASCE 7 and with requirements for seismic-restraint devices in Section 230548 "Vibration and Seismic Controls for HVAC."
- B. Metal Pipe-Hanger Installation: Comply with MSS SP-69 and MSS SP-89. Install hangers, supports, clamps, and attachments as required to properly support piping from the building structure.

- C. Metal Trapeze Pipe-Hanger Installation: Comply with MSS SP-69 and MSS SP-89. Arrange for grouping of parallel runs of horizontal piping, and support together on field-fabricated trapeze pipe hangers.
  - 1. Pipes of Various Sizes: Support together and space trapezes for smallest pipe size or install intermediate supports for smaller diameter pipes as specified for individual pipe hangers.
  - 2. Field fabricate from ASTM A 36, carbon-steel shapes selected for loads being supported. Weld steel according to AWS D1.1.
- D. Metal Framing System Installation: Arrange for grouping of parallel runs of piping, and support together on field-assembled metal framing systems.
- E. Install hangers and supports complete with necessary attachments, inserts, bolts, rods, nuts, washers, and other accessories.
- F. Install hangers and supports to allow controlled thermal and seismic movement of piping systems, to permit freedom of movement between pipe anchors, and to facilitate action of expansion joints, expansion loops, expansion bends, and similar units.
- G. Install lateral bracing with pipe hangers and supports to prevent swaying.
- H. Install building attachments within concrete slabs or attach to structural steel. Install additional attachments at concentrated loads, including valves, flanges, and strainers, NPS 2-1/2 and larger and at changes in direction of piping. Install concrete inserts before concrete is placed; fasten inserts to forms and install reinforcing bars through openings at top of inserts.
- I. Load Distribution: Install hangers and supports so that piping live and dead loads and stresses from movement will not be transmitted to connected equipment.
- J. Pipe Slopes: Install hangers and supports to provide indicated pipe slopes and to not exceed maximum pipe deflections allowed by ASME B31.9 for building services piping.
- K. Insulated Piping:
  - 1. Attach clamps and spacers to piping.
    - a. Piping Operating above Ambient Air Temperature: Clamp may project through insulation.
    - b. Piping Operating below Ambient Air Temperature: Use thermal-hanger shield insert with clamp sized to match OD of insert.
    - c. Do not exceed pipe stress limits allowed by ASME B31.9 for building services piping.
  - 2. Install MSS SP-58, Type 39, protection saddles if insulation without vapor barrier is indicated. Fill interior voids with insulation that matches adjoining insulation.
    - a. Option: Thermal-hanger shield inserts may be used. Include steel weight-distribution plate for pipe NPS 4 and larger if pipe is installed on rollers.
  - 3. Install MSS SP-58, Type 40, protective shields on cold piping with vapor barrier. Shields shall span an arc of 180 degrees.

- a. Option: Thermal-hanger shield inserts may be used. Include steel weight-distribution plate for pipe NPS 4 and larger if pipe is installed on rollers.
4. Shield Dimensions for Pipe: Not less than the following:
  - a. NPS 1/4 to NPS 3-1/2: 12 inches long and 0.048 inch thick.
  - b. NPS 4: 12 inches long and 0.06 inch thick.
  - c. NPS 5 and NPS 6: 18 inches long and 0.06 inch thick.
  - d. NPS 8 to NPS 14: 24 inches long and 0.075 inch thick.
  - e. NPS 16 to NPS 24: 24 inches long and 0.105 inch thick.
5. Pipes NPS 8 and Larger: Include wood or reinforced calcium-silicate-insulation inserts of length at least as long as protective shield.
6. Thermal-Hanger Shields: Install with insulation same thickness as piping insulation.

### 3.2 METAL FABRICATIONS

- A. Cut, drill, and fit miscellaneous metal fabrications for trapeze pipe hangers.
- B. Fit exposed connections together to form hairline joints. Field weld connections that cannot be shop welded because of shipping size limitations.
- C. Field Welding: Comply with AWS D1.1/D1.1M procedures for shielded, metal arc welding; appearance and quality of welds; and methods used in correcting welding work; and with the following:
  1. Use materials and methods that minimize distortion and develop strength and corrosion resistance of base metals.
  2. Obtain fusion without undercut or overlap.
  3. Remove welding flux immediately.
  4. Finish welds at exposed connections so no roughness shows after finishing and so contours of welded surfaces match adjacent contours.

### 3.3 ADJUSTING

- A. Hanger Adjustments: Adjust hangers to distribute loads equally on attachments and to achieve indicated slope of pipe.
- B. Trim excess length of continuous-thread hanger and support rods to 1-1/2 inches.

### 3.4 PAINTING

- A. Touchup: Cleaning and touchup painting of field welds, bolted connections, and abraded areas of shop paint on miscellaneous metal are specified in Division 09.
- B. Galvanized Surfaces: Clean welds, bolted connections, and abraded areas and apply galvanizing-repair paint to comply with ASTM A 780.

## 3.5 HANGER AND SUPPORT SCHEDULE

- A. Specific hanger and support requirements are in Sections specifying piping systems and equipment.
- B. Comply with MSS SP-69 for pipe-hanger selections and applications that are not specified in piping system Sections.
- C. Use hangers and supports with galvanized metallic coatings for piping and equipment that will not have field-applied finish.
- D. Use nonmetallic coatings on attachments for electrolytic protection where attachments are in direct contact with copper tubing.
- E. Use carbon-steel pipe hangers and supports and attachments for general service applications.
- F. Use padded hangers for piping that is subject to scratching.
- G. Use thermal-hanger shield inserts for insulated piping and tubing.
- H. Horizontal-Piping Hangers and Supports: Unless otherwise indicated and except as specified in piping system Sections, install the following types:
  - 1. Adjustable, Steel Clevis Hangers (MSS Type 1): For suspension of noninsulated or insulated, stationary pipes NPS 1/2 to NPS 30.
  - 2. Yoke-Type Pipe Clamps (MSS Type 2): For suspension of up to 1050 deg F, pipes NPS 4 to NPS 24, requiring up to 4 inches of insulation.
  - 3. Carbon- or Alloy-Steel, Double-Bolt Pipe Clamps (MSS Type 3): For suspension of pipes NPS 3/4 to NPS 36, requiring clamp flexibility and up to 4 inches of insulation.
  - 4. Steel Pipe Clamps (MSS Type 4): For suspension of cold and hot pipes NPS 1/2 to NPS 24 if little or no insulation is required.
  - 5. Pipe Hangers (MSS Type 5): For suspension of pipes NPS 1/2 to NPS 4, to allow off-center closure for hanger installation before pipe erection.
  - 6. Adjustable, Swivel Split- or Solid-Ring Hangers (MSS Type 6): For suspension of noninsulated, stationary pipes NPS 3/4 to NPS 8.
  - 7. Adjustable, Steel Band Hangers (MSS Type 7): For suspension of noninsulated, stationary pipes NPS 1/2 to NPS 8.
  - 8. Adjustable Band Hangers (MSS Type 9): For suspension of noninsulated, stationary pipes NPS 1/2 to NPS 8.
  - 9. Adjustable, Swivel-Ring Band Hangers (MSS Type 10): For suspension of noninsulated, stationary pipes NPS 1/2 to NPS 8.
  - 10. Split Pipe Ring with or without Turnbuckle Hangers (MSS Type 11): For suspension of noninsulated, stationary pipes NPS 3/8 to NPS 8.
  - 11. Extension Hinged or Two-Bolt Split Pipe Clamps (MSS Type 12): For suspension of noninsulated, stationary pipes NPS 3/8 to NPS 3.
  - 12. U-Bolts (MSS Type 24): For support of heavy pipes NPS 1/2 to NPS 30.
  - 13. Clips (MSS Type 26): For support of insulated pipes not subject to expansion or contraction.
  - 14. Pipe Saddle Supports (MSS Type 36): For support of pipes NPS 4 to NPS 36, with steel-pipe base stanchion support and cast-iron floor flange or carbon-steel plate.



15. Pipe Stanchion Saddles (MSS Type 37): For support of pipes NPS 4 to NPS 36, with steel-pipe base stanchion support and cast-iron floor flange or carbon-steel plate, and with U-bolt to retain pipe.
  16. Adjustable Pipe Saddle Supports (MSS Type 38): For stanchion-type support for pipes NPS 2-1/2 to NPS 36 if vertical adjustment is required, with steel-pipe base stanchion support and cast-iron floor flange.
  17. Single-Pipe Rolls (MSS Type 41): For suspension of pipes NPS 1 to NPS 30, from two rods if longitudinal movement caused by expansion and contraction might occur.
  18. Adjustable Roller Hangers (MSS Type 43): For suspension of pipes NPS 2-1/2 to NPS 24, from single rod if horizontal movement caused by expansion and contraction might occur.
  19. Complete Pipe Rolls (MSS Type 44): For support of pipes NPS 2 to NPS 42 if longitudinal movement caused by expansion and contraction might occur but vertical adjustment is not necessary.
  20. Pipe Roll and Plate Units (MSS Type 45): For support of pipes NPS 2 to NPS 24 if small horizontal movement caused by expansion and contraction might occur and vertical adjustment is not necessary.
  21. Adjustable Pipe Roll and Base Units (MSS Type 46): For support of pipes NPS 2 to NPS 30 if vertical and lateral adjustment during installation might be required in addition to expansion and contraction.
- I. Vertical-Piping Clamps: Unless otherwise indicated and except as specified in piping system Sections, install the following types:
1. Extension Pipe or Riser Clamps (MSS Type 8): For support of pipe risers NPS 3/4 to NPS 24.
  2. Carbon- or Alloy-Steel Riser Clamps (MSS Type 42): For support of pipe risers NPS 3/4 to NPS 24 if longer ends are required for riser clamps.
- J. Hanger-Rod Attachments: Unless otherwise indicated and except as specified in piping system Sections, install the following types:
1. Steel Turnbuckles (MSS Type 13): For adjustment up to 6 inches for heavy loads.
  2. Steel Clevises (MSS Type 14): For 120 to 450 deg F piping installations.
  3. Swivel Turnbuckles (MSS Type 15): For use with MSS Type 11, split pipe rings.
  4. Malleable-Iron Sockets (MSS Type 16): For attaching hanger rods to various types of building attachments.
  5. Steel Weldless Eye Nuts (MSS Type 17): For 120 to 450 deg F piping installations.
- K. Building Attachments: Unless otherwise indicated and except as specified in piping system Sections, install the following types:
1. Steel or Malleable Concrete Inserts (MSS Type 18): For upper attachment to suspend pipe hangers from concrete ceiling.
  2. Top-Beam C-Clamps (MSS Type 19): For use under roof installations with bar-joist construction, to attach to top flange of structural shape.
  3. Side-Beam or Channel Clamps (MSS Type 20): For attaching to bottom flange of beams, channels, or angles.
  4. Center-Beam Clamps (MSS Type 21): For attaching to center of bottom flange of beams.

5. Welded Beam Attachments (MSS Type 22): For attaching to bottom of beams if loads are considerable and rod sizes are large.
  6. C-Clamps (MSS Type 23): For structural shapes.
  7. Top-Beam Clamps (MSS Type 25): For top of beams if hanger rod is required tangent to flange edge.
  8. Side-Beam Clamps (MSS Type 27): For bottom of steel I-beams.
  9. Steel-Beam Clamps with Eye Nuts (MSS Type 28): For attaching to bottom of steel I-beams for heavy loads.
  10. Linked-Steel Clamps with Eye Nuts (MSS Type 29): For attaching to bottom of steel I-beams for heavy loads, with link extensions.
  11. Malleable-Beam Clamps with Extension Pieces (MSS Type 30): For attaching to structural steel.
  12. Welded-Steel Brackets: For support of pipes from below or for suspending from above by using clip and rod. Use one of the following for indicated loads:
    - a. Light (MSS Type 31): 750 lb.
    - b. Medium (MSS Type 32): 1500 lb.
    - c. Heavy (MSS Type 33): 3000 lb.
  13. Side-Beam Brackets (MSS Type 34): For sides of steel or wooden beams.
  14. Plate Lugs (MSS Type 57): For attaching to steel beams if flexibility at beam is required.
  15. Horizontal Travelers (MSS Type 58): For supporting piping systems subject to linear horizontal movement where headroom is limited.
- L. Saddles and Shields: Unless otherwise indicated and except as specified in piping system Sections, install the following types:
1. Steel-Pipe-Covering Protection Saddles (MSS Type 39): To fill interior voids with insulation that matches adjoining insulation.
  2. Protection Shields (MSS Type 40): Of length recommended in writing by manufacturer to prevent crushing insulation.
  3. Thermal-Hanger Shield Inserts: For supporting insulated pipe.
- M. Spring Hangers and Supports: Unless otherwise indicated and except as specified in piping system Sections, install the following types:
1. Restraint-Control Devices (MSS Type 47): Where indicated to control piping movement.
  2. Spring Cushions (MSS Type 48): For light loads if vertical movement does not exceed 1-1/4 inches.
  3. Spring-Cushion Roll Hangers (MSS Type 49): For equipping Type 41, roll hanger with springs.
  4. Spring Sway Braces (MSS Type 50): To retard sway, shock, vibration, or thermal expansion in piping systems.
  5. Variable-Spring Hangers (MSS Type 51): Preset to indicated load and limit variability factor to 25 percent to allow expansion and contraction of piping system from hanger.
  6. Variable-Spring Base Supports (MSS Type 52): Preset to indicated load and limit variability factor to 25 percent to allow expansion and contraction of piping system from base support.

7. Variable-Spring Trapeze Hangers (MSS Type 53): Preset to indicated load and limit variability factor to 25 percent to allow expansion and contraction of piping system from trapeze support.
8. Constant Supports: For critical piping stress and if necessary to avoid transfer of stress from one support to another support, critical terminal, or connected equipment. Include auxiliary stops for erection, hydrostatic test, and load-adjustment capability. These supports include the following types:
  - a. Horizontal (MSS Type 54): Mounted horizontally.
  - b. Vertical (MSS Type 55): Mounted vertically.
  - c. Trapeze (MSS Type 56): Two vertical-type supports and one trapeze member.
- N. Comply with MSS SP-69 for trapeze pipe-hanger selections and applications that are not specified in piping system Sections.
- O. Comply with MFMA-103 for metal framing system selections and applications that are not specified in piping system Sections.
- P. Use powder-actuated fasteners or mechanical-expansion anchors instead of building attachments where required in concrete construction.

END OF SECTION

**SECTION 23 05 48 - VIBRATION ISOLATION AND SEISMIC RESTRAINT**

All isolation materials, flexible connectors and seismic restraints shall be of the same vendor and shall be selected and certified using published or factory certified data. Any variance or non-compliance with these specification requirements shall be corrected by the contractor in an approved manner.

**PART 1 - SEISMIC DESIGN****1.1 DESCRIPTION**

- A. The work in this section consists of furnishing engineering and materials necessary for the required seismic design of supports and attachments for systems and equipment contained herein for the project.
- B. Other sections of DIVISION 22 & 23 form a part of this section. Refer to all sections for a complete description of the work.
- C. Unless otherwise specified, all mechanical, electrical, fire protection and plumbing equipment, pipe, and duct shall be restrained to resist seismic forces. Restraints shall maintain equipment, piping, and duct work in a captive position.
- D. The 2012 IBC/ASCE 7 requires that mechanical & electrical components be assigned a component importance factor. This importance factor is used to determine which equipment may or may not be exempt from seismic design force requirements. The component importance factor is determined as follows:

$I_p = 1.5$       Life-safety component is required to function after an earthquake.

SEE PROJECT DOCUMENTS FOR COMPONENT AND SYSTEM  $I_p$ 's AND ALL OTHER DESIGN INFORMATION.

**1.2 GENERAL SEISMIC DESIGN REQUIREMENTS:**

- A. Per IBC 1613.1, the seismic restraint of nonstructural components shall meet the requirements of ASCE 7. If the component in question is exempted by Section 13.1.4 of ASCE 7, a submittal noting that seismic restraint of that particular component is not required.
- B. The seismic restraint design must meet the requirements listed in Table 13.2-1 of ASCE 7. These requirements may be met by providing a project-specific design prepared by a registered design professional in the state where the project is being constructed, and a manufacturer's certification that the component is seismically qualified.
- C. On projects with Seismic Design Category C:
  - a. Pipe: Where pipe  $I_p > 1.0$ , brace all pipe  $> 2"$  diameter.

- b. Equipment: Where equipment  $I_p > 1.0$ , provide anchorage or restraint design for all floor, wall mounted or suspended equipment.
- D. On projects with Seismic Design Category D:
1. Seismic anchorage design is not required for floor mounted mechanical, electrical, and plumbing components where  $I_p = 1.0$  and flexible connections between the components and associated duct work, piping and conduit are provided, the components are mounted at 4 feet (1219 mm) or less above a floor level and they weigh 400 pounds (1780 N) or less.
- E. Seismic anchorage or bracing is not required for hanging, wall mounted, and flexibly supported mechanical, plumbing and electrical components that weigh 20 pounds (89 N) or less, where  $I_p = 1.0$  and flexible connections are provided between the components and associated duct work, piping and conduit.
- F. Where equipment  $I_p > 1.0$ , provide anchorage or restraint design for all floor, wall mounted or suspended equipment.
- G. Duct:
1. Where duct  $I_p > 1.0$ , brace all duct  $> 5$  lb/lf
- H. Pipe:
1. Where pipe  $I_p > 1.0$ , brace all pipe  $> 1$ " diameter.
- I. Regardless of Seismic Design Category:
1. Seismic restraints are not required on piping supported by individual clevis hangers where the distance, as measured from the top of the pipe to the supporting structure, is less than 12 inches (305mm) for the entire pipe run and the pipe can accommodate the expected deflections. Trapeze or double rod hangers, where the distance from the top of the trapeze or support to the structure is less than 12 inches for the entire run. HVAC ducts suspended from hangers that are 12 inches (305 mm) or less in length from the top of the duct to the supporting structure and the hangers are detailed to avoid significant bending of the hangers and their connections. Duct must be positively attached to hanger with minimum #10 screws within 2" from the top of the duct. Hanger rods shall not be constructed in a manner that would subject the rod to bending moments (swivel, eye bolt, or vibration isolation hanger connection to structure are required to prevent bending moments when utilizing this exclusion). Displacement of the component shall not cause damaging impact with other utilities or the structure. Flexible connections are required between unbraced systems and equipment to accommodate differential displacements. Where HVAC systems  $I_p > 1.0$ , this exclusion shall not apply (per ASCE 7, 13.6.7).
- J. Brace spacing for low deformability piping and duct (e.g., cast iron, PVC, fiberglass, glass, etc.) shall not exceed one half of the brace spacing of high deformability piping or duct.
- K. Wherever systems or components are vibration isolated, seismic restraints must be designed to prevent short circuiting of the isolation systems.

## L. ANCHORAGE REQUIREMENTS:

1. All post installed anchors utilized in the seismic design must be qualified for use in cracked concrete and approved for use with seismic loads.
2. Expansion anchors shall not be used for anchorage of equipment with motors rated over 10hp with the exception of undercut expansion anchors. Spring or internally isolated equipment are exempt from this requirement.
3. All beam clamps utilized for vertical support must also incorporate retention straps.
4. All seismic brace arm anchorages to include concrete anchors, beam clamps, truss connections, etc., must be approved for use with seismic loads.
5. Calculations and restraint device submittal drawings shall specify anchor bolt type, embedment, concrete compressive strength, minimum spacing between anchors, and minimum distances of anchors from concrete edges. Concrete anchor locations shall not be near edges, stress joints, or an existing fracture. All bolts shall be ASTM A307 or better.
6. Gravity supports must be designed by a licensed engineer in the project state for systems subject to seismic requirements as listed above. Gravity supports include primary support and anchorage of all distributed systems, riser supports, and supports for floor mounted utilities. Design is to include seismic loads in conjunction with dead loads as required by the IBC/ASCE 7.

M. See Part 2 for additional seismic restraint requirements associated with vibration isolated systems and components.

## 1.3 MANUFACTURER'S RESPONSIBILITIES

- A. The following seismic restraint manufacturers are accepted: International Seismic Application Technology (ISAT), Amber / Booth, Mason Industries Inc. (M.I.), Kinetics Noise Control Inc. (K.N.C.), Vibration Mounting & Controls, Inc. (V.M.C.) and Vibro Acoustics.
- B. Determine vibration isolation and seismic restraint sizes and locations.
- C. Provide installation instructions and shop drawings for all materials supplied under this section of the specifications.
- D. Provide calculations to determine restraint loads resulting from seismic forces presented in local building code or IBC, Chapter 16 latest edition. Seismic calculations shall be certified by the manufacturers engineer licensed in the state of Utah.
- E. Seismic restraint load ratings must be certified and substantiated by testing or calculations under direct control of a registered professional engineer. Copies of testing and calculations must be submitted as part of submittal documents. OSHPD pre-approved restraint systems are exempt from this requirement if their pre-approval is current and based upon the IBC 2012 (i.e. OPA-07 pre-approval numbers).

## 1.4 QUALITY CONTROL

- A. All seismic restraint components exposed to the weather shall be zinc or cadmium-plated, epoxy coat or PVC coated, and/or galvanized steel. Nuts, bolts and washers

may be zinc-electroplated. Restraints for outdoor mounted components shall provide adequate restraint for the greater of either wind or seismic loads required by local codes or withstand a minimum of 30 lb. / sq. ft. applied to any exposed surface of the equipment.

- B. Seismic restraint designer must provide, in writing, the special inspection requirements for all Designated Seismic Systems as indicated in Chapter 17 of the IBC.

## 1.5 SUBMITTALS

- A. Each contractor responsible for the installation of Designated Seismic Systems (systems with component  $I_p > 1.0$ ) must submit a "Statement of Responsibility" as required by Section 1706.1 of the IBC 2012, prior to beginning work on the system or component.
- B. Submittal documents must include a "Basis for Design" or "Design Criteria" which includes a statement from the registered design professional that the design complies with the requirements of the ASCE 7, Chapter 13 and IBC 2012 chapter 1909/ACI 318 (concrete anchors).
- C. Submittals must include seismic bracing layout drawings indicating the location of all seismic restraints. The submittal package must include seismic restraint details providing specific information relating to the materials, type, size, and locations of anchorages; materials used for bracing; attachment requirements of bracing to structure and component; and locations of transverse and longitudinal sway bracing and rod stiffeners.
- D. Catalog cut sheets and installation instructions shall be included for each type seismic restraint used on equipment or components being restrained.
- E. Submit special inspection requirements as required under 1.4 at time of seismic submittals.
- F. Submittal drawings and calculations must be stamped by a registered professional engineer in the State where the project is being constructed who is responsible for the seismic restraint design. All seismic restraint submittals not complying with this certification will be rejected.

## 1.6 SEISMIC CERTIFICATION OF EQUIPMENT

- A. For equipment or components where  $I_p = 1.0$ .
- B. Submittal documents must include a "Basis for Design" or "Design Criteria" which includes a statement from the registered design professional that the design complies with the requirements of the ASCE 7, Chapter 13 and IBC 2012 chapter 1909/ACI 318 (concrete anchors). In addition, the basis for compliance must also be noted, as listed below:
  - 1. Project specific design documentation prepared and submitted by a registered design professional (ASCE 7, 13.2.1.1)

2. Submittal of the manufacturer's certification that the equipment is seismically qualified by:
    - a. An engineered analysis conforming to the requirements of Chapter 13 of ASCE 7.
    - b. Testing by a nationally recognized testing standard procedure such as ICC-ES AC 156. The substantiated seismic design capacities shall exceed the seismic demands determined by Section 13.3 of ASCE 7.
    - c. Experience data conforming to a nationally recognized procedure. The substantiated seismic design capacities shall exceed the seismic demands determined by Section 13.3 of ASCE 7.
  3. The equipment and components listed below are considered rugged and shall not require Special Seismic Certification:
    - a. Valves (not in cast-iron housings, except for ductile cast iron).
    - b. Pneumatic operators.
    - c. Hydraulic operators.
    - d. Motors and motor operators.
    - e. Horizontal and vertical pumps (including vacuum pumps).
    - f. Air compressors
    - g. Refrigerators and freezers.
    - h. Elevator cabs.
    - i. Underground tanks.
    - j. Equipment and components weighing not more than 20 lbs. supported directly on structures (and not mounted on other equipment or components) with supports and attachments in accordance with Chapter 13, ASCE 7.
  4. Exemptions in this section are for factory assembled discrete equipment and components only and do not apply to site assembled or field assembled equipment or equipment anchorage. The list is based in part on OSHPD Code Application Notice 2-1708A.5.
- C. Special Certification requirements for Designated Seismic Systems (i.e.  $I_p > 1.0$ ):  
Seismic Certificates of Compliance supplied by manufacturers shall be submitted for all components that are part of Designated Seismic Systems. In accordance with the ASCE 7, certification shall be via one of the following methods:
1. For active mechanical and electrical equipment that must remain operable following the design earthquake:
    - a. Testing as detailed by part c above.
    - b. Experience data as detailed by part c above.
    - c. Equipment that is considered "rugged" per part c above.
  2. Components with hazardous contents shall be certified by the manufacturer as maintaining containment following the design earthquake by:
    - a. Testing as detailed by part c above.
    - b. Experience data as detailed by part c above.
    - c. Engineering analysis utilizing dynamic characteristics and forces. Tanks (without vibration isolators) designed by a registered design professional in accordance with ASME Boiler and Pressure Vessel Code, 2007 (BPVC 2007),



and satisfying the force and displacement requirements of Sections 13.3.1 and 13.3.2 of ASCE 7 having an importance factor,  $I = 1.5$  and reviewed by DFCM shall be considered to satisfy the Special Seismic Certification requirements on the basis of ASCE 7 Section 13.6.9.

## 1.7 INSTALLATION

- A. Comply with manufacturer/engineer's instructions for the installation of seismic restraint materials and products.

## PART 2 - VIBRATION ISOLATION

See Part 1 for seismic design requirements. Additional seismic design requirements are outlined below where they pertain specifically to vibration isolated components or systems.

## 2.1 DESCRIPTION

- A. The work in this section consists of furnishing engineering and materials necessary for vibration isolation for systems and equipment contained herein for the project.
- B. Other sections of DIVISION 21, 22 & 23 form a part of this section. Refer to all sections for a complete description of the work.
- C. All mechanical equipment .75 HP and over listed in the equipment schedule shall be mounted on vibration isolators to prevent the transmission of objectionable vibration and vibration induced sound to the building structure.
- D. All isolation materials, flexible connectors and seismic restraints shall be of the same vendor and shall be selected and certified using published or factory certified data. Any variance or non-compliance with these specification requirements shall be corrected by the contractor in an approved manner.
- E. The contractor and vendor of the isolation and seismic restraints for floor mounted equipment shall refer to the isolator and seismic restraint schedule which lists isolator types, isolator deflections and seismic restraint type. Vibration isolators shall be selected in accordance with the equipment, pipe or duct weight distribution so as to produce reasonably uniform deflections.
- F. Install full line size flexible pipe connectors at the inlet and outlet of each pump, cooling tower, condenser, chiller, coiling connections and where shown on the drawings. All connectors shall be suitable for use at the temperature, pressure, and service encountered at the point of installation and operation. End fitting connectors shall conform to the pipefitting schedule. Control rods or protective braid must be used to limit elongation to 3/8". Flexible connectors shall not be required for suspended in-line pumps.

## 2.2 MANUFACTURER'S RESPONSIBILITIES

- A. Manufacturer of vibration and seismic restraint products shall have the following responsibilities:
  - 1. Determine vibration isolation and seismic restraint sizes and locations.
  - 2. Provide installation instructions and shop drawings for all materials supplied under this section of the specifications.
  - 3. Provide calculations to determine equipment restraint loads resulting from seismic forces presented in local building code or IBC, Chapter 16 latest edition. Seismic calculations shall be certified by the manufacturers engineer licensed in the state of Utah.
- B. Seismic restraint load ratings must be certified and substantiated by testing or calculations under direct control of a registered professional engineer.
- C. Calculations and restraint device submittal drawings shall meet the requirements of Part 1, Seismic Design.

## 2.3 QUALITY CONTROL

- A. The isolators and seismic restraint systems listed herein are as manufactured by International Seismic Application Technology (ISAT), Amber / Booth, Mason Industries Inc. (M.I.), Kinetics Noise Control Inc. (K.N.C.), California Dynamics (CalDyn), Vibration Mounting & Controls, Inc. (V.M.C.) and Vibro Acoustics.
- B. Steel components shall be cleaned and painted with industrial enamel. All nuts, bolts and washers shall be zinc-electroplated. Structural steel bases shall be thoroughly cleaned of welding slag and primed with zinc-chromate or metal etching primer.
- C. All isolators, bases and seismic restraints exposed to the weather shall utilize weather resistant plating, epoxy coat or PVC coated springs and galvanized steel components. Nuts, bolts and washers may be zinc-electroplated. Isolators for outdoor mounted equipment shall provide adequate restraint for the greater of either wind loads required by local codes or withstand a minimum of 30 lb. / sq. ft. applied to any exposed surface of the equipment.
- D. Vibration isolation designer must provide a written special inspection plan as indicated in Chapter 17 of the IBC.

## 2.4 SUBMITTALS

- A. Submit shop drawings of all isolators, seismic restraints and calculations provided.
- B. The manufacturer of vibration isolation products shall submit the following data for each piece of isolated equipment: clearly identified equipment tag, quantity and size of vibration isolators and seismic restraints for each piece of rotating isolated equipment. Submittals for mountings and hangers incorporating springs shall include spring diameter and free height, rated deflections, and solid load. Submittals for bases shall clearly identify locations for all mountings as well as all locations for attachment points of the equipment to the mounting base. Submittals shall include

seismic calculations signed and checked by a qualified licensed engineer in the state where the project is being constructed. Catalog cut sheets and installation instructions shall be included for each type of isolation mounting or seismic restraint used on equipment being isolated.

- C. Submit special inspection requirements as required under 2.4 at time of isolator/seismic submittals. Submittal must be stamped by a registered Utah professional engineer who is responsible for the vibration isolation and seismic restraint design. All vibration isolation not complying with this certification will be rejected.
- D. Submittal documents must include a "Basis for Design" or "Design Criteria" which includes a statement from the registered design professional that the design complies with the requirements of the ASCE 7, Chapter 13 and IBC 2012 chapter 1909/ACI 318 (concrete anchors). In addition, the basis for compliance must also be noted, as listed below:
  - 1. Project specific design documentation prepared and submitted by a registered design professional (ASCE 7, 13.2.1.1)
  - 2. Submittal of the manufacturer's certification that the isolation equipment is seismically qualified by:
    - a. An engineered analysis conforming to the requirements of Chapter 13 of ASCE 7.
    - b. Testing by a nationally recognized testing standard procedure such as ICC-ES AC 156. The substantiated seismic design capacities shall exceed the seismic demands determined by Section 13.3 of ASCE 7.
    - c. Experience data conforming to a nationally recognized procedure. The substantiated seismic design capacities shall exceed the seismic demands determined by Section 13.3 of ASCE 7.

## 2.5 VIBRATION ISOLATION PRODUCTS

### A. ISOLATORS

- 1. Specification W: a pad type mounting consisting of two layers of ribbed elastomeric pads with a 1/2" poro-elastic vibration absorptive material bonded between them. Pads shall be sized for approximate deflection of 0.10" to 0.18". Pads shall be Amber / Booth Type NRC or equal.

### B. ROOFTOP UNIT CURBS AND ISOLATION SYSTEMS

- 1. Specification W: Non-isolated seismically rated rooftop curb system that is flashed into roofing membrane. Air and watertight curb shall have a neoprene sponge seal at the top and be rigid enough provide continuous perimeter support for rooftop unit. Curb must provide means to positively anchor to concrete deck, or bolt or weld directly to structural steel to withstand seismic loading. Curb shall provide a means by which contractor supplied insulation may be installed for thermal insulation and acoustic attenuation. Curbs shall accommodate roof pitch shown on drawings. Curb shall use minimum 16 gage galvanized steel and shall be designed with crossbracing required to withstand the greater of seismic forces (para 1.3.4.) or wind loading per local building code. Design must be

certified by registered professional engineer in the employ of the manufacturer. Seismic curbs shall be Amber/Booth Type RTC or equal.

C. FLEXIBLE PIPE CONNECTIONS

1. Specification K: Water Service: For flanged connection – a double sphere arch rubber expansion joint constructed of molded reinforced neoprene with integral steel floating flanges, and designed to be suitable for pressures up to 225 PSI (4 to 1 safety factor) and temperatures up to 225 °F. Connectors shall have minimum movement capabilities of 1.77" compression, 1.18" lateral and 1.18" extension. Connectors shall provide a minimum 35° angular movement up to 6", minimum 30° up to 12" and minimum 20° up to 24". Spring-loaded control units shall be furnished to limit movement to within allowables. Amber/Booth Type 2600 or equal.
2. Water Service: For threaded type – A double spherical rubber hose connector, minimum 8" long, constructed of molded neoprene, nylon cord reinforced, with female pipe unions each end. Connectors shall have a minimum movement capability of 7/8" compression, 7/8" lateral, 1/4" extension and 20° angular through 1-1/4", 13° through 2", and 9° through 3". Connectors shall be suitable for a maximum working pressure (4 to 1 safety factor) of 150 psi and 225 degree F. Connectors shall have cable control units to limit extension to 1/4". Amber/Booth Type 2655 or equal.
3. Specification L: Steam and Condensate Service:
  - a. For flanged connection – a metal hose connector constructed of stainless steel hose and braid with carbon steel plate flanges. Live lengths shall conform to hose minimum length to absorb thermal and dynamic movement. Hose axis must be perpendicular to pipe movement. Amber/Booth Type SS-FP or SS-FW or equal.
  - b. For threaded connections - a metal hose connector constructed of stainless steel hose and braid with carbon steel NPT threaded end fittings. Minimum lengths shall conform to the following table:

1-1/2" dia. (and smaller) x 10" long
2" x 12"
2-1/2" x 13"
3" x 14"
3-1/2" x 16"
4" x 16"

- c. Amber/Booth Type SS-PM or equal.

PART 3 - EXECUTION

Isolator and seismic restraints shall be installed as recommended by the manufacturer. Isolate all mechanical equipment 0.75 hp and over per the isolation schedule and these specifications.

3.1 PIPING ISOLATION

- A. Horizontal Pipe Isolation: all HVAC pumped water, pumped condensate, glycol, and refrigerant piping size 1-1/4" and larger within mechanical rooms shall be isolated. Outside equipment rooms this piping shall be isolated for the greater of 50' or 100 pipe diameters from rotating equipment. For the first 3 support locations from externally isolated equipment provide specification E hangers or specification SB or SX floor mounts with the same deflection as equipment isolators (max 2"). All other piping within the equipment rooms shall be isolated with the same specification isolators with a 3/4" minimum deflection. Steam piping size 1-1/4" and larger which is within an equipment room and connected to rotating equipment shall be isolated for three (3) support locations from the equipment. Provide specification E or SB (SX) isolators with the same deflection as the equipment but a minimum of 3/4"
- B. All plumbing pumped water, pumped condensate, and steam piping size 1-1/4" and larger within mechanical rooms shall be isolated the same as HVAC piping (para. 3.2.1). Isolators are not required for any plumbing pumped water, pumped condensate, and steam piping outside of mechanical rooms unless listed in the isolation schedule (para. 3.5.5.)

### 3.2 INSTALLATION

- A. Comply with manufacturer's instructions for the installation and load application of vibration isolation materials and products. Adjust to ensure that units do not exceed rated operating deflections or bottom out under loading, and are not short-circuited by other contacts or bearing points. Remove space blocks and similar devices (if any) intended for temporary support during installation or shipping.
- B. Locate isolation hangers as near the overhead support structure as possible.
- C. Adjust leveling devices as required to distribute loading uniformly on isolators. Shim units as required where leveling devices cannot be used to distribute loading properly.
- D. Install isolated inertia base frames and steel bases on isolator units as indicated so that a minimum of 2 inch clearance below base will result when supported equipment has been installed and loaded for operation.
- E. Roof curbs shall be installed directly to building structural steel or concrete roof deck. Installation on top of steel deck or roofing material is not acceptable.

### 3.3 APPLICATION OF SEISMIC RESTRAINTS

- A. All floor mounted isolated equipment shall be protected with type SB or type C unitized isolator and restraint or with separate type SL restraints (minimum of 4) in conjunction with type B isolators. For equipment with high center of gravity additional cable restraints shall be furnished, as required by isolation manufacturer, to limit forces and motion caused by rocking.
- B. Floor mounted which are exempt (section 2.2.) shall be protected by properly sized anchor bolts with elastomeric grommets provided by the isolation manufacturer

- C. Where riser pipes pass through cored holes, core diameters to be a maximum of 2" larger than pipe O.D. including insulation. Cored holes must be packed with resilient material or firestop as provided by other sections of this specification or local codes. Restrained isolators type C or SB shall support risers and provide longitudinal restraint at floors where thermal expansion is minimal and will not bind isolator restraints.

3.4 QUALITY ASSURANCE

- A. Representative of vibration isolation system manufacturer to walk the project and provide documentation indicating conformance to vibration isolation design intent (see example below)

EQUIPMENT ISOLATION SCHEDULE (1)(4)									
EQUIPMENT	LOCATI ON								
	A' CRITIC AL (35'-50' SPAN)			B' UPPER STORY (20'-35' SPAN)			C' GRADE		
	ISOLA TOR TYPE	MINIMU M DEFLEC TION (IN)	BASE (1) TYPE	ISOLA TOR TYPE	MINIMU M DEFLEC TION (IN)	BASE (1) TYPE	ISOLAT OR TYPE	MINIMU M DEFLEC TION (IN)	BASE (1) TYPE
AIR HANDLING UNITS FLOOR MOUNTED									
UP TO 15 HP	SWSR	1.5		SWSR	0.75		SWSR	0.75	
20 HP & OVER	SWSR	2.5	WSB	SWSR	1.5		SWSR	0.75	
SUSPENDED (4)									
UP TO 15 HP	PBSRA	1.75		BSRA	1		BSRA	1	
20 HP & OVER	PBSRA	2.5	WSB	PBSRA	1.75		PBSRA A	1	
HIGH PRESSURE FAN SECTIONS (2)									
UP TO 30 HP	SW	2.5	CPF	SWISW SR	1.5	CPF	SWISW SR	0.75	CPF
40 HP & OVER	SW	3.5	CPF	SWISW SR	2.5	CPF	SWISW SR	1.5	CPF
CENTRIFUGAL FANS CL. I & II UP TO 54-112" W.D.									
UPT015HP	SWISW SR	1.5	SFB	SWISW SR	0.75	SFB	SWISW SR	0.75	SFB
20-50 HP	SW	2.5	CPF	SWISW SR	1.5	CPF	SWISW SR	0.75	SFB
60 HP & OVER	SW	3.5	CPF	SW	2.5	CPF	SWISW SR	1.5	SFB
CL. I & II 60" W.D. & OVER ALL CL. III FANS									
UPT015HP	SW	2.5	CPF	SWISW SR	1.5	CPF	SWISW SR	0.75	CPF

20-50 H P	SW	2.5	CPF	SW	2.5	CPF	SWISW SR	1.5	CPF
60 HP & OVER	SW	3.5	CPF	SW	2.5	CPF	SWISW SR	1.5	CPF
AXIAL FLOWFANS (2) FLOOR MTD.									
UP TO 15 HP	SWISW SR	1.5	WSB	SWSR	0.75		SWSR	0.75	
20 HP & OVER SUSPENDED (4)	SW	3.5	CPF	SWSR	1.5		SWSR	0.75	
UP TO 15 HP	PBSRA	1.75	WSB	BSRA PBSR A	1		BSRA PBSR A	1	
20 HP & OVER	PBSRA	2.5	WSB		1.75	WSB		1.5	
VENT (UTILITY SETS) FLOOR MTD	SWISW SR	1.5	WSB	SWSR	0.75		SWSR	0.75	
SUSPENDED (4)	BSRA	1.75	WSB	BSRA	1		BSRA	0.75	
CABINET FANS, FANS SECTIONS (2) FLOOR MTD.									
UP TO 15 HP	SWSR	1.5		SWSR	0.75		SWSR	0.75	
20 HP & OVER SUSPENDED (4)	SW	2.5	CPF	SWSR	1.5		SWSR	0.75	
UP TO 15 HP	PBSRA	1.75		BSRA PBSR A	1		BSRA	0.75	
20 HP & OVER	PBSRA	2.5	WSB		1.75		BSRA	1.75	
PUMPS FLOOR MTD.									
UP TO 15 HP	SWISW SR	0.75	CPF	SWISW SR	0.75	CPF	SRVD	0.4	CPF
7-112 HP & OVER SUSPENDED INLINE	SWISW SR	1.5	CPF	SWISW SR	1.5	CPF	SWISW SR	0.75	CPF
	PBSRA	1.75		PBSRA	1.75		PBSRA	1	
REFRIGERATION UNITS RECIPROCATING COMPRESSORS	SW	2.5	CPF	SWISW SR	1.5	CPF	SWISW SR	0.75	CPF
RECIPROCATING CONDO UNITS & CHILLERS	SW	2.5	CPF	CTER	1.5		SWSR	0.75	
HERMETIC CENTRIFUGALS	CTER	2.5		CTER	1.5		NRC	0.15	
OPEN CENTRIFUGALS	SW	2.5	CPF	SWISW SR	1.5	CPF	NRC	0.15	
ABSORPTION MACHINES	CTER	1.5		CTER	0.75		NRC	0.15	
AIR COMPRESSORS TANK TYPE (HORIZONTAL TANK)	SW	2.5	CPF	SWSR	1.5		SWS R	0.75	
TANK TYPE (VERTICAL TANK)	SW	2.5	CPF	SWISW SR	1.5	CPF	SWS R	0.75	
COOLING TOWERS & CLOSED CIRCUIT COOLERS									
UP TO 500 TONS	CTER	2.5	(3)	CTER	0.75	(3)	NRC	0.15	
OVER 500 TONS	CTER	4.5	(3)	CTER	2.5	(3)	NRC	0.15	
AIR COOLED CONDENSERS									

UP TO 50 TONS	CTER	1.5	(3)	CTER	0.75	(3)	NRC	0.15	
OVER 50 TONS	CTER	2.5	(3)	CTER	1.5	(3)	NRC	0.15	
ROOFTOP AIR CONDITIONING UNITS REQUIRING WEATHER SEAL UP TO 5000 CFM (12 TON)	SW	1.5	RTIR	SW	0.75	RTIR			
OVER 5000 CFM (12 TON)	CTER	2.5	RTIC	CTE R	1.5	RTIC			
OTHER TYPES UP TO 25 TONS	CTER	1.5	(3)	CTER	1.5	(3)			
OVER 25 TONS	CTER	2.5	(3)	CTER	1.5	(3)			
BOILER (PACKAGE TYPE) ALL SIZES	CTER	1.5		CTER	0.75		NRC	0.15	
ENGINE DRIVEN GENERATORS UP TO 60 HP	SW	2.5	CPF	CTER	1.5	CPF	CTER	0.75	
75 HP & OVER	SW	3.5	CPF	CTER	2.5	CPF	CTER	0.75	

NOTES:

- 1) WITH TYPE ER SEISMIC SNUBBERS IF SW ISOLATORS ARE USED. NO ADDITIONAL SNUBBER IS REQUIRED FOR SWSR ISOLATORS.
- 2) TYPE TRK THRUST RESISTORS REQUIRED ON ALL HIGH PRESSURE FAN SECTIONS, SUSPENDED AXIAL FLOW FANS AND ON FLOOR MOUNTED AXIAL FANS OPERATING AT 3" S.P. OR GREATER.
- 3) WITH STEEL BASE TYPE WSB IF REQUIRED FOR SUPPORT.

END OF SECTION



**SECTION 23 05 50 - OPERATION AND MAINTENANCE OF HVAC SYSTEMS**

## PART 1 - GENERAL

## 1.1 RELATED DOCUMENTS

- A. All pertinent sections of Division 21, 22, & 23 Mechanical General Requirements, are part of the work of this Section. Division 1 is part of this and all other sections of these specifications.
  - 1. Testing and Balancing is specified in section 230594.
  - 2. Training and Instructions to Owner's Representative is specified in section 230100.

## 1.2 SCOPE OF WORK

- A. Submission of Operating and Maintenance Manuals complete with Balancing reports. (Coordinate with Division 1).
- B. Coordination of work required for system commissioning.
- C. Provide a hard copy and an electronic copy on CD of the O and M manual fully searchable in PDF format.

## 1.3 SUBMITTALS

- A. Submit product data in accordance with Division 1 and Section 230100. Submit the following:
  - 1. Sample of O and M manual outline.

## PART 2 - PRODUCTS

## 2.1 O &amp; M MANUALS

- A. The operating and maintenance manuals shall be as follows:
  - 1. Binders shall be red buckram with easy-view metal for size 8-1/2 x 11-inch sheets, with capacity expandable from 2 inches to 3-1/2 inches as required for the project. Construction shall be rivet-through with library corners. No. 12 backbone and lining shall be the same material as the cover. The front cover and backbone shall be foil-stamped in white as follows: (coordinate with Division 01 )

OPERATING AND MAINTENANCE  
MANUAL  
FOR THE

(INSERT PROJECT NAME)

(INSERT PROJECT COMPLETION YEAR)

VOLUME No. ( )

VAN BOERUM & FRANK ASSOCIATES, INC.  
MECHANICAL ENGINEER

(INSERT ARCHITECT)

### PART 3 - EXECUTION

#### 3.1 OPERATING AND MAINTENANCE MANUALS:

- A. Work under this section shall be performed in concert with the contractor performing the system testing and balancing. Six (6) copies of the manuals shall be furnished to the Architect for distribution to the owner.
- B. The "Start-Up and Operation" section is one of the most important in the manual. Information in this section shall be complete and accurately written and shall be verified with the actual equipment on the job, such as switches, starters, relays, automatic controls, etc. A step-by-step start-up procedure shall be described.
- C. The manuals shall include air and water-balancing reports, system commissioning procedures, start-up tests and reports, equipment and system performance test reports, warranties, and certificates of training given to the owner's representatives.

An index sheet typed on AICO Gold-Line indexes shall be provided in the front of the binder. The manual shall include the following:

SYSTEM DESCRIPTIONS

START-UP PROCEDURE AND OPERATION OF SYSTEM

MAINTENANCE AND LUBRICATION TABLE

OPERATION AND MAINTENANCE BULLETINS

AUTOMATIC TEMPERATURE CONTROL DESCRIPTION OF OPERATION, INTERLOCK AND CONTROL DIAGRAMS, AND CONTROL PANELS.

AIR AND WATER SYSTEM BALANCING REPORTS

EQUIPMENT WARRANTIES AND TRAINING CERTIFICATES

SYSTEM COMMISSIONING REPORTS

EQUIPMENT START-UP CERTIFICATES

END OF SECTION

**SECTION 23 05 53 - IDENTIFICATION FOR HVAC PIPING AND EQUIPMENT**

## PART 1 - GENERAL

## 1.1 RELATED DOCUMENTS

- A. Drawings and general provisions of the Contract, including General and Supplementary Conditions and Division 01 Specification Sections, apply to this Section.

## 1.2 SUMMARY

- A. Section Includes:

1. Equipment labels.
2. Danger, Warning and Caution signs and labels.
3. Pipe labels.
4. Duct labels.
5. Stencils.
6. Valve tags.
7. Danger tags.
8. Warning tags.
9. Caution tags.

## 1.3 ACTION SUBMITTALS

- A. Product Data: For each type of product indicated.
- B. Equipment Label Schedule: Include a listing of all equipment to be labeled with the proposed content for each label.
- C. Valve numbering scheme.
- D. Valve Schedules: For each piping system to include in maintenance manuals.

## 1.4 COORDINATION

- A. Coordinate installation of identifying devices with completion of covering and painting of surfaces where devices are to be applied.
- B. Coordinate installation of identifying devices with locations of access panels and doors.
- C. Install identifying devices before installing acoustical ceilings and similar concealment.

## PART 2 - PRODUCTS

## 2.1 EQUIPMENT LABELS

## A. Metal Labels for Equipment:

1. Material and Minimum Thickness, predrilled or stamped holes for attachment hardware:
  - a. Brass, 0.032-inch .
2. Minimum Label Size: Length and width vary for required label content, but not less than 2-1/2 by 3/4 inch.
3. Minimum Letter Size: 1/4 inch for name of units if viewing distance is less than 24 inches, 1/2 inch for viewing distances up to 72 inches, and proportionately larger lettering for greater viewing distances. Include secondary lettering two-thirds to three-fourths the size of principal lettering.
4. Fasteners: Stainless-steel;
  - a. Rivets or self-tapping screws
5. Adhesive: Contact-type permanent adhesive, compatible with label and with substrate.

## B. Plastic Labels for Equipment:

1. Material and Thickness: Multilayer, multicolor, plastic labels for mechanical engraving, and having predrilled holes for attachment hardware, 1/16 inch thick.
2. Letter Color:
  - a. Black.
3. Background Color:
  - a. White.
4. Maximum Temperature: Able to withstand temperatures up to 160 deg F.
5. Minimum Label Size: Length and width vary for required label content, but not less than 2-1/2 by 3/4 inch.
6. Minimum Letter Size: 1/4 inch for name of units if viewing distance is less than 24 inches, 1/2 inch for viewing distances up to 72 inches, and proportionately larger lettering for greater viewing distances. Include secondary lettering two-thirds to three-fourths the size of principal lettering.
7. Fasteners: Stainless-steel;
  - a. Rivets or self-tapping screws
8. Adhesive: Contact-type permanent adhesive, compatible with label and with substrate.

## C. Label Content: Include equipment's Drawing designation or unique equipment number, Drawing numbers where equipment is indicated (plans, details, and schedules), plus the Specification Section number and title where equipment is specified.

## D. Equipment Label Schedule: For each item of equipment to be labeled, on 8-1/2-by-11-inch bond paper. Tabulate equipment identification number and identify Drawing numbers where equipment is indicated (plans, details, and schedules), plus the Specification Section number and title where equipment is specified. Equipment schedule shall be included in operation and maintenance data.

## 2.2 DANGER, WARNING AND CAUTION SIGNS AND LABELS

- A. Material and Thickness: Multilayer, multicolor, plastic labels for mechanical engraving, having predrilled holes for attachment hardware; 1/16 inch thick.
- B. Danger signs, colors:
  - 1. Letter Color:
    - a. White.
  - 2. Background Color:
    - a. Red.
- C. Warning signs, colors:
  - 1. Letter Color:
    - a. Black.
  - 2. Background Color:
    - a. Orange.
- D. Caution signs, colors:
  - 1. Letter Color:
    - a. Black.
  - 2. Background Color:
    - a. Yellow.
- E. Maximum Temperature: Able to withstand temperatures up to 160 deg F.
- F. Minimum Label Size: Length and width vary for required label content, but not less than 2-1/2 by 3/4 inch.
- G. Minimum Letter Size: 1/4 inch for name of units if viewing distance is less than 24 inches, 1/2 inch for viewing distances up to 72 inches, and proportionately larger lettering for greater viewing distances. Include secondary lettering two-thirds to three-fourths the size of principal lettering.
- H. Fasteners: Stainless-steel;
  - 1. Rivets or self-tapping screws
- I. Adhesive: Contact-type permanent adhesive, compatible with label and with substrate.
- J. Label Content: Include caution and warning information, plus emergency notification instructions.

## 2.3 PIPE LABELS

- A. General Requirements for Manufactured Pipe Labels: Preprinted, color-coded, with lettering indicating service, and showing flow direction.
- B. Pretensioned Pipe Labels: Precoiled, semirigid plastic formed to partially cover circumference of pipe and to attach to pipe without fasteners or adhesive.
- C. Self-Adhesive Pipe Labels: Printed plastic with contact-type, permanent-adhesive backing.

- D. Pipe Label Contents: Include identification of piping service using same designations or abbreviations as used on Drawings, pipe size, and an arrow indicating flow direction.

- 1. Flow-Direction Arrows: Integral with piping system service lettering to accommodate both directions, or as separate unit on each pipe label to indicate flow direction.
- 2. Lettering Size: At least 1-1/2 inches high.

## 2.4 DUCT LABELS

- A. Material and Thickness: Multilayer, multicolor, plastic labels for mechanical engraving, having predrilled holes for attachment hardware; 1/16 inch thick.
- B. Letter Color:
  - 1. White.
- C. Background Color:
  - 1. Black.
- D. Maximum Temperature: Able to withstand temperatures up to 160 deg F.
- E. Minimum Label Size: Length and width vary for required label content, but not less than 2-1/2 by 3/4 inch.
- F. Minimum Letter Size: 1/4 inch for name of units if viewing distance is less than 24 inches, 1/2 inch for viewing distances up to 72 inches, and proportionately larger lettering for greater viewing distances. Include secondary lettering two-thirds to three-fourths the size of principal lettering.
- G. Fasteners: Stainless-steel;
  - 1. Rivets or self-tapping screws
- H. Adhesive: Contact-type permanent adhesive, compatible with label and with substrate.
- I. Duct Label Contents: Include identification of duct service using same designations or abbreviations as used on Drawings, duct size, and an arrow indicating flow direction.
  - 1. Flow-Direction Arrows: Integral with duct system service lettering to accommodate both directions, or as separate unit on each duct label to indicate flow direction.
  - 2. Lettering Size: At least 1-1/2 inches high.

## 2.5 STENCILS

- A. Stencils: Prepared with letter sizes according to ASME A13.1 for piping; minimum letter height of 1-1/4 inches for ducts; and minimum letter height of 3/4 inch for access panel and door labels, equipment labels, and similar operational instructions.
  - 1. Stencil Material:
    - a. Aluminum.

2. Stencil Paint:
  - a. Exterior, gloss, alkyd enamel black unless otherwise indicated.
  - b. Paint may be in pressurized spray-can form.
3. Identification Paint:
  - a. Exterior, alkyd enamel in colors according to ASME A13.1 unless otherwise indicated.

## 2.6 VALVE TAGS

- A. Valve Tags: Stamped or engraved with 1/4-inch letters for piping system abbreviation and 1/2-inch numbers.
  1. Tag Material, predrilled or stamped holes for attachment hardware, minimum thickness:
    - a. Brass, 0.032-inch
  2. Fasteners: Brass;
    - a. Wire-link or beaded chain; or S-hook
  3. For each piping system, on 8-1/2-by-11-inch bond paper, tabulate:
    - a. Valve number.
    - b. Piping system.
    - c. System abbreviation (as shown on valve tag).
    - d. Location of valve (room or space).
    - e. Normal-operating position (open, closed, or modulating).
    - f. Variations for identification.
    - g. Mark valves for emergency shutoff and similar special uses.
  4. Valve-tag schedule:
    - a. Shall be included in operation and maintenance data.

## 2.7 DANGER TAGS

- A. Danger Tags: Preprinted or partially preprinted, accident-prevention tags, of plasticized card stock with matte finish suitable for writing.
  1. Size:
    - a. 3 by 5-1/4 inches minimum
  2. Fasteners:
    - a. Brass grommet and wire.
  3. Nomenclature: Large-size primary caption such as "DANGER," and "DO NOT OPERATE."
  4. Color: Red background with white lettering.

## 2.8 WARNING TAGS

- A. Warning Tags: Preprinted or partially preprinted, accident-prevention tags, of plasticized card stock with matte finish suitable for writing.
  1. Size:

- a. 3 by 5-1/4 inches minimum
2. Fasteners:
  - a. Brass grommet and wire.
3. Nomenclature: Large-size primary caption such as "WARNING" and "DO NOT OPERATE."
4. Color: Yellow background with black lettering.

## 2.9 CAUTION TAGS

- A. Caution Tags: Preprinted or partially preprinted, accident-prevention tags, of plasticized card stock with matte finish suitable for writing.
  1. Size:
    - a. 3 by 5-1/4 inches minimum
  2. Fasteners:
    - a. Brass grommet and wire.
  3. Nomenclature: Large-size primary caption such as "CAUTION," and "DO NOT OPERATE."
  4. Color: Orange background with black lettering.

## PART 3 - EXECUTION

### 3.1 PREPARATION

- A. Clean piping and equipment surfaces of substances that could impair bond of identification devices, including dirt, oil, grease, release agents, and incompatible primers, paints, and encapsulants.

### 3.2 EQUIPMENT LABEL INSTALLATION

- A. Install or permanently fasten labels on each major item of mechanical equipment.
- B. Locate equipment labels where accessible and visible.
- C. Where equipment is located above a ceiling, the equipment type and number shall be placed on the t-bar grid under the equipment location, or at the corner of an access door that has been provided for valve access above hard lid ceilings.

### 3.3 PIPE LABEL INSTALLATION

- A. Piping Color-Coding: Painting of piping is specified in Division 09.
- B. Stenciled Pipe Label Option:
  1. Stenciled labels may be provided instead of manufactured pipe labels, at Installer's option.



2. Install stenciled pipe labels with painted, color-coded bands or rectangles on each piping system.
  - a. Identification Paint: Use for contrasting background.
  - b. Stencil Paint: Use for pipe marking.
- C. Locate pipe labels where piping is exposed or above accessible ceilings in finished spaces; machine rooms; accessible maintenance spaces such as shafts, tunnels, and plenums; and exterior exposed locations as follows:
  1. Near each valve and control device.
  2. Near each branch connection, excluding short takeoffs for fixtures and terminal units. Where flow pattern is not obvious, mark each pipe at branch.
  3. Near penetrations through walls, floors, ceilings, and inaccessible enclosures.
  4. At access doors, manholes, and similar access points that permit view of concealed piping.
  5. Near major equipment items and other points of origination and termination.
  6. Spaced at maximum intervals of 50 feet along each run. Reduce intervals to 25 feet in areas of congested piping and equipment.
  7. On piping above removable acoustical ceilings. Omit intermediately spaced labels.
- D. Pipe Label Color Schedule: (See Drawing Schedules)

### 3.4 DUCT LABEL INSTALLATION

- A. Install plastic-laminated duct labels with permanent adhesive on air ducts in the following color codes:
  1. Blue: For cold-air supply ducts.
  2. Yellow: For hot-air supply ducts.
  3. Green: For exhaust-, outside-, relief-, return-, and mixed-air ducts.
  4. ASME A13.1 Colors and Designs: For hazardous material exhaust.
- B. Locate labels near points where ducts enter into concealed spaces and at maximum intervals of 50 feet in each space where ducts are exposed or concealed by removable ceiling system.

### 3.5 VALVE-TAG INSTALLATION (See Drawing Schedules.)

- A. Install tags on valves and control devices in piping systems, except check valves; valves within factory-fabricated equipment units; shutoff valves; faucets; convenience and lawn-watering hose connections; and HVAC terminal devices and similar roughing-in connections of end-use fixtures and units. List tagged valves in a valve schedule.

3.6 WARNING-TAG INSTALLATION

- A. Write required message on, and attach warning tags to, equipment and other items where required.

END OF SECTION

**SECTION 23 05 93 - TESTING, ADJUSTING, AND BALANCING FOR HVAC**

## PART 1 - GENERAL

## 1.1 RELATED DOCUMENTS

- A. Drawings and general provisions of the Contract, including General and Supplementary Conditions and Division 01 Specification Sections, apply to this Section.

## 1.2 SUMMARY

- A. Section Includes:
  - 1. Balancing Air Systems:
    - a. Constant-volume air systems.
    - b. Variable-air-volume systems.
  - 2. Balancing Hydronic Piping Systems:
    - a. Constant-flow hydronic systems.
    - b. Variable-flow hydronic systems.
    - c. Primary-secondary hydronic systems.
  - 3. Various HVAC Equipment.
    - a. Motors.
    - b. Heat Transfer Coils.

## 1.3 DEFINITIONS

- A. AABC: Associated Air Balance Council.
- B. NEBB: National Environmental Balancing Bureau.
- C. TAB: Testing, adjusting, and balancing.
- D. TABB: Testing, Adjusting, and Balancing Bureau.
- E. TAB Specialist: An entity engaged to perform TAB Work.

## 1.4 INFORMATIONAL SUBMITTALS

- A. Qualification Data: Within the following number of days of the Contractor's Notice to Proceed, submit documentation that the TAB contractor and this Project's TAB team members meet the qualifications specified in "Quality Assurance" Article;
  - 1. 30 days.

- B. Certified TAB reports.
- C. Instrument calibration reports, to include the following:
  - 1. Instrument type and make.
  - 2. Serial number.
  - 3. Application.
  - 4. Dates of use.
  - 5. Dates of calibration.

## 1.5 QUALITY ASSURANCE

- A. TAB Contractor Qualifications: Engage a TAB entity certified by AABC or NEBB.
  - 1. TAB Field Supervisor: Employee of the TAB contractor and certified by AABC or NEBB and shall be the same as the TAB Contractor.
  - 2. TAB Technician: Employee of the TAB contractor and who is certified by AABC or NEBB as a TAB technician and shall be the same as the TAB Contractor.
- B. Certify TAB field data reports and perform the following:
  - 1. Review field data reports to validate accuracy of data and to prepare certified TAB reports.
  - 2. Certify that the TAB team complied with the approved TAB plan and the procedures specified and referenced in this Specification.
- C. TAB Report Forms: Use standard TAB contractor's forms approved by:
  - 1. Architect.
- D. Instrumentation Type, Quantity, Accuracy, and Calibration: As described in ASHRAE 111, Section 5, "Instrumentation."

## 1.6 PROJECT CONDITIONS

- A. Full Owner Occupancy: Owner will occupy the site and existing building during entire TAB period. Cooperate with Owner during TAB operations to minimize conflicts with Owner's operations.

## 1.7 COORDINATION

- A. Notice: Provide seven days' advance notice for each test. Include scheduled test dates and times.
- B. Perform TAB after leakage and pressure tests on the following distribution systems have been satisfactorily completed:
  - 1. Air and water.

## PART 2 - PRODUCTS (Not Applicable)

## PART 3 - EXECUTION

## 3.1 TAB SPECIALISTS

A. Subject to compliance with requirements, engage one of the following:

1. BTC Service.
2. Certified Test & Balance.
3. Diamond Test & Balance.
4. RS Analysis.
5. Test & Balance Inc.
6. Payson Sheetmetal.

## 3.2 EXAMINATION

- A. Examine the Contract Documents to become familiar with Project requirements and to discover conditions in systems' designs that may preclude proper TAB of systems and equipment.
- B. Examine systems for installed balancing devices, such as test ports, gage cocks, thermometer wells, flow-control devices, balancing valves and fittings, and manual volume dampers. Verify that locations of these balancing devices are accessible.
- C. Examine the approved submittals for HVAC systems and equipment.
- D. Examine design data including HVAC system descriptions, statements of design assumptions for environmental conditions and systems' output, and statements of philosophies and assumptions about HVAC system and equipment controls.
- E. Examine:
1. Ceiling plenums and underfloor air plenums used for supply, return, or relief air to verify that they meet the leakage class of connected ducts as specified in:
    - a. Section 233113 "Metal Ducts"
  2. Verify ceiling plenums and underfloor air plenums used for supply, return or relief air are properly separated from adjacent areas.
  3. Verify that penetrations in plenum walls are sealed and fire-stopped if required.
- F. Examine equipment performance data including fan and pump curves.
1. Relate performance data to Project conditions and requirements, including system effects that can create undesired or unpredicted conditions that cause reduced capacities in all or part of a system.
  2. Calculate system-effect factors to reduce performance ratings of HVAC equipment when installed under conditions different from the conditions used to rate equipment performance. To calculate system effects for air systems, use tables and charts found in AMCA 201, "Fans and Systems," or in SMACNA's "HVAC Systems - Duct Design." Compare results with the design data and installed conditions.

- G. Examine system and equipment installations and verify that field quality-control testing, cleaning, and adjusting specified in individual Sections have been performed.
- H. Examine test reports specified in individual system and equipment Sections.
- I. Examine HVAC equipment and filters and verify that bearings are greased, belts are aligned and tight, and equipment with functioning controls is ready for operation.
- J. Examine terminal units, such as variable-air-volume boxes, and verify that they are accessible and their controls are connected and functioning.
- K. Examine strainers. Verify that startup screens are replaced by permanent screens with indicated perforations.
- L. Examine three-way valves for proper installation for their intended function of diverting or mixing fluid flows.
- M. Examine heat-transfer coils for correct piping connections and for clean and straight fins.
- N. Examine system pumps to ensure absence of entrained air in the suction piping.
- O. Examine operating safety interlocks and controls on HVAC equipment.
- P. Report deficiencies discovered before and during performance of TAB procedures. Observe and record system reactions to changes in conditions. Record default set points if different from indicated values.

### 3.3 PREPARATION

- A. Prepare a TAB plan that includes strategies and step-by-step procedures.
- B. Complete system-readiness checks and prepare reports. Verify the following:
  - 1. Permanent electrical-power wiring is complete.
  - 2. Hydronic systems are filled, clean, and free of air.
  - 3. Automatic temperature-control systems are operational.
  - 4. Equipment and duct access doors are securely closed.
  - 5. Balance, smoke, and fire dampers are open.
  - 6. Isolating and balancing valves are open and control valves are operational.
  - 7. Ceilings are installed in critical areas where air-pattern adjustments are required and access to balancing devices is provided.
  - 8. Windows and doors can be closed so indicated conditions for system operations can be met.

### 3.4 GENERAL PROCEDURES FOR TESTING AND BALANCING

- A. Perform testing and balancing procedures on each system according to the procedures contained in this section and:
  - 1. AABC's "National Standards for Total System Balance"

- B. Cut insulation, ducts, pipes, and equipment cabinets for installation of test probes to the minimum extent necessary for TAB procedures.
  - 1. After testing and balancing, patch probe holes in ducts with same material and thickness as used to construct ducts.
  - 2. Install and join new insulation that matches removed materials. Restore insulation, coverings, vapor barrier, and finish according to Section 230713 "Duct Insulation," Section 230716 "HVAC Equipment Insulation," and Section 230719 "HVAC Piping Insulation."
- C. Mark equipment and balancing devices, including damper-control positions, valve position indicators, fan-speed-control levers, and similar controls and devices, with paint or other suitable, permanent identification material to show final settings.
- D. Take and report testing and balancing measurements in inch-pound (IP).

### 3.5 GENERAL PROCEDURES FOR BALANCING AIR SYSTEMS

- A. Prepare test reports for both fans and outlets. Obtain manufacturer's outlet factors and recommended testing procedures. Crosscheck the summation of required outlet volumes with required fan volumes.
- B. Prepare schematic diagrams of systems' "as-built" duct layouts.
- C. For variable-air-volume systems, develop a plan to simulate diversity.
- D. Determine the best locations in main and branch ducts for accurate duct-airflow measurements.
- E. Check airflow patterns from the outdoor-air louvers and dampers and the return- and exhaust-air dampers through the supply-fan discharge and mixing dampers.
- F. Locate start-stop and disconnect switches, electrical interlocks, and motor starters.
- G. Verify that motor starters are equipped with properly sized thermal protection.
- H. Check dampers for proper position to achieve desired airflow path.
- I. Check for airflow blockages.
- J. Check condensate drains for proper connections and functioning.
- K. Check for proper sealing of air-handling-unit components.
- L. Verify that air duct system is sealed as specified in Section 233113 "Metal Ducts."

### 3.6 PROCEDURES FOR CONSTANT-VOLUME AIR SYSTEMS

- A. Adjust fans to deliver total indicated airflows within the maximum allowable fan speed listed by fan manufacturer.

1. Measure total airflow.
    - a. Where sufficient space in ducts is unavailable for Pitot-tube traverse measurements, measure airflow at terminal outlets and inlets and calculate the total airflow.
  2. Measure fan static pressures as follows to determine actual static pressure:
    - a. Measure outlet static pressure as far downstream from the fan as practical and upstream from restrictions in ducts such as elbows and transitions.
    - b. Measure static pressure directly at the fan outlet or through the flexible connection.
    - c. Measure inlet static pressure of single-inlet fans in the inlet duct as near the fan as possible, upstream from the flexible connection, and downstream from duct restrictions.
    - d. Measure inlet static pressure of double-inlet fans through the wall of the plenum that houses the fan.
  3. Measure static pressure across each component that makes up an air-handling unit, rooftop unit, and other air-handling and -treating equipment.
    - a. Report the cleanliness status of filters and the time static pressures are measured.
  4. Measure static pressures entering and leaving other devices, such as sound traps, heat-recovery equipment, and air washers, under final balanced conditions.
  5. Review Record Documents to determine variations in design static pressures versus actual static pressures. Calculate actual system-effect factors. Recommend adjustments to accommodate actual conditions.
  6. Obtain approval from one of the following entities for adjustment of fan speed higher or lower than indicated speed. Comply with requirements in HVAC Sections for air-handling units for adjustment of fans, belts, and pulley sizes to achieve indicated air-handling-unit performance:
    - a. Architect.
  7. Do not make fan-speed adjustments that result in motor overload. Consult equipment manufacturers about fan-speed safety factors. Modulate dampers and measure fan-motor amperage to ensure that no overload will occur. Measure amperage in full-cooling, full-heating, economizer, and any other operating mode to determine the maximum required brake horsepower.
- B. Adjust volume dampers for main duct, submain ducts, and major branch ducts to indicated airflows within specified tolerances.
1. Measure airflow of submain and branch ducts.
    - a. Where sufficient space in submain and branch ducts is unavailable for Pitot-tube traverse measurements, measure airflow at terminal outlets and inlets and calculate the total airflow for that zone.
  2. Measure static pressure at a point downstream from the balancing damper, and adjust volume dampers until the proper static pressure is achieved.



3. Remeasure each submain and branch duct after all have been adjusted. Continue to adjust submain and branch ducts to indicated airflows within specified tolerances.
- C. Measure air outlets and inlets without making adjustments.
1. Measure terminal outlets using a direct-reading hood or outlet manufacturer's written instructions and calculating factors.
- D. Adjust air outlets and inlets for each space to indicated airflows within specified tolerances of indicated values. Make adjustments using branch volume dampers rather than extractors and the dampers at air terminals.
1. Adjust each outlet in same room or space to within specified tolerances of indicated quantities without generating noise levels above the limitations prescribed by the Contract Documents.
  2. Adjust patterns of adjustable outlets for proper distribution without drafts.

### 3.7 PROCEDURES FOR VARIABLE-AIR-VOLUME SYSTEMS

- A. Compensating for Diversity: When the total airflow of all terminal units is more than the indicated airflow of the fan, place a selected number of terminal units at a minimum set-point airflow with the remainder at maximum-airflow condition until the total airflow of the terminal units equals the indicated airflow of the fan. Select the reduced-airflow terminal units so they are distributed evenly among the branch ducts.
- B. Pressure-Independent, Variable-Air-Volume Systems: After the fan systems have been adjusted, adjust the variable-air-volume systems as follows:
1. Set outdoor-air dampers at minimum, and set return- and exhaust-air dampers at a position that simulates full-cooling load.
  2. Select the terminal unit that is most critical to the supply-fan airflow and static pressure. Measure static pressure. Adjust system static pressure so the entering static pressure for the critical terminal unit is not less than the sum of the terminal-unit manufacturer's recommended minimum inlet static pressure plus the static pressure needed to overcome terminal-unit discharge system losses.
  3. Measure total system airflow. Adjust to within indicated airflow.
  4. Set terminal units at maximum airflow and adjust controller or regulator to deliver the designed maximum airflow. Use terminal-unit manufacturer's written instructions to make this adjustment. When total airflow is correct, balance the air outlets downstream from terminal units the same as described for constant-volume air systems.
  5. Set terminal units at minimum airflow and adjust controller or regulator to deliver the designed minimum airflow. Check air outlets for a proportional reduction in airflow the same as described for constant-volume air systems.
    - a. If air outlets are out of balance at minimum airflow, report the condition but leave outlets balanced for maximum airflow.
  6. Remeasure the return airflow to the fan while operating at maximum return airflow and minimum outdoor airflow.

7. Measure static pressure at the most critical terminal unit and adjust the static-pressure controller at the main supply-air sensing station to ensure that adequate static pressure is maintained at the most critical unit.
  8. Record final fan-performance data.
- C. Pressure-Dependent, Variable-Air-Volume Systems without Diversity: After the fan systems have been adjusted, adjust the variable-air-volume systems as follows:
1. Balance variable-air-volume systems the same as described for constant-volume air systems.
  2. Set terminal units and supply fan at full-airflow condition.
  3. Adjust inlet dampers of each terminal unit to indicated airflow and verify operation of the static-pressure controller. When total airflow is correct, balance the air outlets downstream from terminal units the same as described for constant-volume air systems.
  4. Readjust fan airflow for final maximum readings.
  5. Measure operating static pressure at the sensor that controls the supply fan if one is installed, and verify operation of the static-pressure controller.
  6. Set terminal units at minimum airflow and adjust controller or regulator to deliver the designed minimum airflow. Check air outlets for a proportional reduction in airflow the same as described for constant-volume air systems.
    - a. If air outlets are out of balance at minimum airflow, report the condition but leave the outlets balanced for maximum airflow.
  7. Measure the return airflow to the fan while operating at maximum return airflow and minimum outdoor airflow.
- D. Pressure-Dependent, Variable-Air-Volume Systems with Diversity: After the fan systems have been adjusted, adjust the variable-air-volume systems as follows:
1. Set system at maximum indicated airflow by setting the required number of terminal units at minimum airflow. Select the reduced-airflow terminal units so they are distributed evenly among the branch ducts.
  2. Adjust supply fan to maximum indicated airflow with the variable-airflow controller set at maximum airflow.
  3. Set terminal units at full-airflow condition.
  4. Adjust terminal units starting at the supply-fan end of the system and continuing progressively to the end of the system. Adjust inlet dampers of each terminal unit to indicated airflow. When total airflow is correct, balance the air outlets downstream from terminal units the same as described for constant-volume air systems.
  5. Adjust terminal units for minimum airflow.
  6. Measure the return airflow to the fan while operating at maximum return airflow and minimum outdoor airflow. Adjust the fan and balance the return-air ducts and inlets the same as described for constant-volume air systems.

### 3.8 GENERAL PROCEDURES FOR HYDRONIC SYSTEMS

- A. Prepare test reports with pertinent design data, and number in sequence starting at pump to end of system. Check the sum of branch-circuit flows against the approved pump flow rate. Correct variations that exceed plus or minus 5 percent.

- B. Prepare schematic diagrams of systems' "as-built" piping layouts.
- C. Prepare hydronic systems for testing and balancing according to the following, in addition to the general preparation procedures specified above:
  - 1. Open all manual valves for maximum flow.
  - 2. Check liquid level in expansion tank.
  - 3. Check makeup water-station pressure gage for adequate pressure for highest vent.
  - 4. Check flow-control valves for specified sequence of operation, and set at indicated flow.
  - 5. Set differential-pressure control valves at the specified differential pressure. Do not set at fully closed position when pump is positive-displacement type unless several terminal valves are kept open.
  - 6. Set system controls so automatic valves are wide open to heat exchangers.
  - 7. Check pump-motor load. If motor is overloaded, throttle main flow-balancing device so motor nameplate rating is not exceeded.
  - 8. Check air vents for a forceful liquid flow exiting from vents when manually operated.

### 3.9 PROCEDURES FOR CONSTANT-FLOW HYDRONIC SYSTEMS

- A. Measure water flow at pumps. Use the following procedures except for positive-displacement pumps:
  - 1. Verify impeller size by operating the pump with the discharge valve closed. Read pressure differential across the pump. Convert pressure to head and correct for differences in gage heights. Note the point on manufacturer's pump curve at zero flow and verify that the pump has the intended impeller size.
    - a. If impeller sizes must be adjusted to achieve pump performance, obtain approval from the following entity and comply with requirements in Section 232123 "Hydronic Pumps."
      - 1) Architect.
  - 2. Check system resistance. With all valves open, read pressure differential across the pump and mark pump manufacturer's head-capacity curve. Adjust pump discharge valve until indicated water flow is achieved.
    - a. Monitor motor performance during procedures and do not operate motors in overload conditions.
  - 3. Verify pump-motor brake horsepower. Calculate the intended brake horsepower for the system based on pump manufacturer's performance data. Compare calculated brake horsepower with nameplate data on the pump motor. Report conditions where actual amperage exceeds motor nameplate amperage.
  - 4. Report flow rates that are not within plus or minus 10 percent of design.
- B. Measure flow at all automatic flow control valves to verify that valves are functioning as designed.

- C. Measure flow at all pressure-independent characterized control valves, with valves in fully open position, to verify that valves are functioning as designed.
- D. Set calibrated balancing valves, if installed, at calculated presettings.
- E. Measure flow at all stations and adjust, where necessary, to obtain first balance.
  - 1. System components that have Cv rating or an accurately cataloged flow-pressure-drop relationship may be used as a flow-indicating device.
- F. Measure flow at main balancing station and set main balancing device to achieve flow that is 5 percent greater than indicated flow.
- G. Adjust balancing stations to within specified tolerances of indicated flow rate as follows:
  - 1. Determine the balancing station with the highest percentage over indicated flow.
  - 2. Adjust each station in turn, beginning with the station with the highest percentage over indicated flow and proceeding to the station with the lowest percentage over indicated flow.
  - 3. Record settings and mark balancing devices.
- H. Measure pump flow rate and make final measurements of pump amperage, voltage, rpm, pump heads, and systems' pressures and temperatures including outdoor-air temperature.
- I. Measure the differential-pressure-control-valve settings existing at the conclusion of balancing.
- J. Check settings and operation of each safety valve. Record settings.

### 3.10 PROCEDURES FOR VARIABLE-FLOW HYDRONIC SYSTEMS

- A. Balance systems with automatic two- and three-way control valves by setting systems at maximum flow through heat-exchange terminals and proceed as specified above for hydronic systems.

### 3.11 PROCEDURES FOR PRIMARY-SECONDARY HYDRONIC SYSTEMS

- A. Balance the primary circuit flow first and then balance the secondary circuits.

### 3.12 PROCEDURES FOR MOTORS

- A. Motors, 1/2 HP and Larger: Test at final balanced conditions and record the following data:
  - 1. Manufacturer's name, model number, and serial number.
  - 2. Motor horsepower rating.
  - 3. Motor rpm.
  - 4. Efficiency rating.

5. Nameplate and measured voltage, each phase.
  6. Nameplate and measured amperage, each phase.
  7. Starter thermal-protection-element rating.
- B. Motors Driven by Variable-Frequency Controllers: Test for proper operation at speeds varying from minimum to maximum. Test the manual bypass of the controller to prove proper operation. Record observations including name of controller manufacturer, model number, serial number, and nameplate data.

### 3.13 PROCEDURES FOR HEAT-TRANSFER COILS

- A. Measure, adjust, and record the following data for each water coil:
1. Entering- and leaving-water temperature.
  2. Water flow rate.
  3. Water pressure drop.
  4. Dry-bulb temperature of entering and leaving air.
  5. Wet-bulb temperature of entering and leaving air for cooling coils.
  6. Airflow.
  7. Air pressure drop.
- B. Measure, adjust, and record the following data for each electric heating coil:
1. Nameplate data.
  2. Airflow.
  3. Entering- and leaving-air temperature at full load.
  4. Voltage and amperage input of each phase at full load and at each incremental stage.
  5. Calculated kilowatt at full load.
  6. Fuse or circuit-breaker rating for overload protection.
- C. Measure, adjust, and record the following data for each steam coil:
1. Dry-bulb temperature of entering and leaving air.
  2. Airflow.
  3. Air pressure drop.
  4. Inlet steam pressure.
- D. Measure, adjust, and record the following data for each refrigerant coil:
1. Dry-bulb temperature of entering and leaving air.
  2. Wet-bulb temperature of entering and leaving air.
  3. Airflow.
  4. Air pressure drop.
  5. Refrigerant suction pressure and temperature.

### 3.14 TOLERANCES

- A. Set HVAC system's air flow rates and water flow rates within the following tolerances:

1. Supply, Return, and Exhaust Fans and Equipment with Fans: Plus or minus 10 percent.
2. Air Outlets and Inlets: Plus or minus 10 percent.
3. Heating-Water Flow Rate: Plus or minus 10 percent.
4. Cooling-Water Flow Rate: Plus or minus 10 percent.

### 3.15 REPORTING

- A. Initial Construction-Phase Report: Based on examination of the Contract Documents as specified in "Examination" Article, prepare a report on the adequacy of design for systems' balancing devices. Recommend changes and additions to systems' balancing devices to facilitate proper performance measuring and balancing. Recommend changes and additions to HVAC systems and general construction to allow access for performance measuring and balancing devices.
- B. Status Reports: Prepare progress reports on the following interval to describe completed procedures, procedures in progress, and scheduled procedures. Include a list of deficiencies and problems found in systems being tested and balanced. Prepare a separate report for each system and each building floor for systems serving multiple floors;
  1. Weekly.

### 3.16 FINAL REPORT

- A. General: Prepare a certified written report; tabulate and divide the report into separate sections for tested systems and balanced systems.
  1. Include a certification sheet at the front of the report's binder, signed and sealed by the certified testing and balancing engineer.
  2. Include a list of instruments used for procedures, along with proof of calibration.
- B. Final Report Contents: In addition to certified field-report data, include the following:
  1. Pump curves.
  2. Fan curves.
  3. Manufacturers' test data.
  4. Field test reports prepared by system and equipment installers.
  5. Other information relative to equipment performance; do not include Shop Drawings and product data.
- C. General Report Data: In addition to form titles and entries, include the following data:
  1. Title page.
  2. Name and address of the TAB contractor.
  3. Project name.
  4. Project location.
  5. Architect's name and address.
  6. Engineer's name and address.
  7. Contractor's name and address.
  8. Report date.
  9. Signature of TAB supervisor who certifies the report.

10. Table of Contents with the total number of pages defined for each section of the report. Number each page in the report.
  11. Summary of contents including the following:
    - a. Indicated versus final performance.
    - b. Notable characteristics of systems.
    - c. Description of system operation sequence if it varies from the Contract Documents.
  12. Nomenclature sheets for each item of equipment.
  13. Data for terminal units, including manufacturer's name, type, size, and fittings.
  14. Notes to explain why certain final data in the body of reports vary from indicated values.
  15. Test conditions for fans and pump performance forms including the following:
    - a. Settings for outdoor-, return-, and exhaust-air dampers.
    - b. Conditions of filters.
    - c. Cooling coil, wet- and dry-bulb conditions.
    - d. Face and bypass damper settings at coils.
    - e. Fan drive settings including settings and percentage of maximum pitch diameter.
    - f. Inlet vane settings for variable-air-volume systems.
    - g. Settings for supply-air, static-pressure controller.
    - h. Other system operating conditions that affect performance.
- D. System Diagrams: Include schematic layouts of air and hydronic distribution systems. Present each system with single-line diagram and include the following:
1. Quantities of outdoor, supply, return, and exhaust airflows.
  2. Water and steam flow rates.
  3. Duct, outlet, and inlet sizes.
  4. Pipe and valve sizes and locations.
  5. Terminal units.
  6. Balancing stations.
  7. Position of balancing devices.
- E. Air-Handling-Unit Test Reports: For air-handling units with coils, include the following:
1. Unit Data:
    - a. Unit identification.
    - b. Location.
    - c. Make and type.
    - d. Model number and unit size.
    - e. Manufacturer's serial number.
    - f. Unit arrangement and class.
    - g. Discharge arrangement.
    - h. Sheave make, size in inches, and bore.
    - i. Center-to-center dimensions of sheave, and amount of adjustments in inches.
    - j. Number, make, and size of belts.
    - k. Number, type, and size of filters.

2. Motor Data:
    - a. Motor make, and frame type and size.
    - b. Horsepower and rpm.
    - c. Volts, phase, and hertz.
    - d. Full-load amperage and service factor.
    - e. Sheave make, size in inches, and bore.
    - f. Center-to-center dimensions of sheave, and amount of adjustments in inches.
  3. Test Data (Indicated and Actual Values):
    - a. Total air flow rate in cfm.
    - b. Total system static pressure in inches wg.
    - c. Fan rpm.
    - d. Discharge static pressure in inches wg.
    - e. Filter static-pressure differential in inches wg.
    - f. Preheat-coil static-pressure differential in inches wg.
    - g. Cooling-coil static-pressure differential in inches wg.
    - h. Heating-coil static-pressure differential in inches wg.
    - i. Outdoor airflow in cfm.
    - j. Return airflow in cfm.
    - k. Outdoor-air damper position.
    - l. Return-air damper position.
    - m. Vortex damper position.
- F. Apparatus-Coil Test Reports:
1. Coil Data:
    - a. System identification.
    - b. Location.
    - c. Coil type.
    - d. Number of rows.
    - e. Fin spacing in fins per inch o.c.
    - f. Make and model number.
    - g. Face area in sq. ft..
    - h. Tube size in NPS.
    - i. Tube and fin materials.
    - j. Circuiting arrangement.
  2. Test Data (Indicated and Actual Values):
    - a. Air flow rate in cfm.
    - b. Average face velocity in fpm.
    - c. Air pressure drop in inches wg.
    - d. Outdoor-air, wet- and dry-bulb temperatures in deg F.
    - e. Return-air, wet- and dry-bulb temperatures in deg F.
    - f. Entering-air, wet- and dry-bulb temperatures in deg F.
    - g. Leaving-air, wet- and dry-bulb temperatures in deg F.
    - h. Water flow rate in gpm.
    - i. Water pressure differential in feet of head or psig.
    - j. Entering-water temperature in deg F.



- k. Leaving-water temperature in deg F.
  - l. Refrigerant expansion valve and refrigerant types.
  - m. Refrigerant suction pressure in psig.
  - n. Refrigerant suction temperature in deg F.
  - o. Inlet steam pressure in psig.
- G. Fan Test Reports: For supply, return, and exhaust fans, include the following:
- 1. Fan Data:
    - a. System identification.
    - b. Location.
    - c. Make and type.
    - d. Model number and size.
    - e. Manufacturer's serial number.
    - f. Arrangement and class.
    - g. Sheave make, size in inches, and bore.
    - h. Center-to-center dimensions of sheave, and amount of adjustments in inches.
  - 2. Motor Data:
    - a. Motor make, and frame type and size.
    - b. Horsepower and rpm.
    - c. Volts, phase, and hertz.
    - d. Full-load amperage and service factor.
    - e. Sheave make, size in inches, and bore.
    - f. Center-to-center dimensions of sheave, and amount of adjustments in inches.
    - g. Number, make, and size of belts.
  - 3. Test Data (Indicated and Actual Values):
    - a. Total airflow rate in cfm.
    - b. Total system static pressure in inches wg.
    - c. Fan rpm.
    - d. Discharge static pressure in inches wg.
    - e. Suction static pressure in inches wg.
- H. Round, Flat-Oval, and Rectangular Duct Traverse Reports: Include a diagram with a grid representing the duct cross-section and record the following:
- 1. Report Data:
    - a. System and air-handling-unit number.
    - b. Location and zone.
    - c. Traverse air temperature in deg F.
    - d. Duct static pressure in inches wg.
    - e. Duct size in inches.
    - f. Duct area in sq. ft..
    - g. Indicated air flow rate in cfm.
    - h. Indicated velocity in fpm.
    - i. Actual air flow rate in cfm.

- j. Actual average velocity in fpm.
  - k. Barometric pressure in psig.
- I. Air-Terminal-Device Reports:
- 1. Unit Data:
    - a. System and air-handling unit identification.
    - b. Location and zone.
    - c. Apparatus used for test.
    - d. Area served.
    - e. Make.
    - f. Number from system diagram.
    - g. Type and model number.
    - h. Size.
    - i. Effective area in sq. ft..
  - 2. Test Data (Indicated and Actual Values):
    - a. Air flow rate in cfm.
    - b. Air velocity in fpm.
    - c. Preliminary air flow rate as needed in cfm.
    - d. Preliminary velocity as needed in fpm.
    - e. Final air flow rate in cfm.
    - f. Final velocity in fpm.
    - g. Space temperature in deg F.
- J. System-Coil Reports: For reheat coils and water coils of terminal units, include the following:
- 1. Unit Data:
    - a. System and air-handling-unit identification.
    - b. Location and zone.
    - c. Room or riser served.
    - d. Coil make and size.
    - e. Flowmeter type.
  - 2. Test Data (Indicated and Actual Values):
    - a. Air flow rate in cfm.
    - b. Entering-water temperature in deg F.
    - c. Leaving-water temperature in deg F.
    - d. Water pressure drop in feet of head or psig.
    - e. Entering-air temperature in deg F.
    - f. Leaving-air temperature in deg F.
- K. Pump Test Reports: Calculate impeller size by plotting the shutoff head on pump curves and include the following:
- 1. Unit Data:
    - a. Unit identification.

- b. Location.
- c. Service.
- d. Make and size.
- e. Model number and serial number.
- f. Water flow rate in gpm.
- g. Water pressure differential in feet of head or psig.
- h. Required net positive suction head in feet of head or psig.
- i. Pump rpm.
- j. Impeller diameter in inches.
- k. Motor make and frame size.
- l. Motor horsepower and rpm.
- m. Voltage at each connection.
- n. Amperage for each phase.
- o. Full-load amperage and service factor.
- p. Seal type.

2. Test Data (Indicated and Actual Values):

- a. Static head in feet of head or psig.
- b. Pump shutoff pressure in feet of head or psig.
- c. Actual impeller size in inches.
- d. Full-open flow rate in gpm.
- e. Full-open pressure in feet of head or psig.
- f. Final discharge pressure in feet of head or psig.
- g. Final suction pressure in feet of head or psig.
- h. Final total pressure in feet of head or psig.
- i. Final water flow rate in gpm.
- j. Voltage at each connection.
- k. Amperage for each phase.

L. Instrument Calibration Reports:

1. Report Data:

- a. Instrument type and make.
- b. Serial number.
- c. Application.
- d. Dates of use.
- e. Dates of calibration.

### 3.17 INSPECTIONS

A. Initial Inspection:

1. After testing and balancing are complete, operate each system and randomly check measurements to verify that the system is operating according to the final test and balance readings documented in the final report.
2. Check the following for each system:
  - a. Measure airflow of at least 10 percent of air outlets.
  - b. Measure water flow of at least 5 percent of terminals.

- c. Measure room temperature at each thermostat/temperature sensor. Compare the reading to the set point.
      - d. Verify that balancing devices are marked with final balance position.
      - e. Note deviations from the Contract Documents in the final report.
  - B. Final Inspection:
    1. After initial inspection is complete and documentation by random checks verifies that testing and balancing are complete and accurately documented in the final report, request that a final inspection be made by:
      - a. Architect.
    2. The TAB contractor's test and balance engineer shall conduct the inspection in the presence of:
      - a. Architect.
    3. The following entity shall randomly select measurements, documented in the final report, to be rechecked. Rechecking shall be limited to either 10 percent of the total measurements recorded or the extent of measurements that can be accomplished in a normal 8-hour business day:
      - a. Architect.
    4. If rechecks yield measurements that differ from the measurements documented in the final report by more than the tolerances allowed, the measurements shall be noted as "FAILED."
    5. If the number of "FAILED" measurements is greater than 10 percent of the total measurements checked during the final inspection, the testing and balancing shall be considered incomplete and shall be rejected.
  - C. TAB Work will be considered defective if it does not pass final inspections. If TAB Work fails, proceed as follows:
    1. Recheck all measurements and make adjustments. Revise the final report and balancing device settings to include all changes; resubmit the final report and request a second final inspection.
    2. If the second final inspection also fails, Owner may contract the services of another TAB contractor to complete TAB Work according to the Contract Documents and deduct the cost of the services from the original TAB contractor's final payment.
  - D. Prepare test and inspection reports.
- 3.18 ADDITIONAL TESTS
- A. Within 90 days of completing TAB, perform additional TAB to verify that balanced conditions are being maintained throughout and to correct unusual conditions.
  - B. Seasonal Periods: If initial TAB procedures were not performed during near-peak summer and winter conditions, perform additional TAB during near-peak summer and winter conditions.

END OF SECTION

**SECTION 23 07 13 - DUCT INSULATION**

## PART 1 - GENERAL

## 1.1 RELATED DOCUMENTS

- A. Drawings and general provisions of the Contract, including General and Supplementary Conditions and Division 01 Specification Sections, apply to this Section.

## 1.2 SUMMARY

- A. Section includes insulating the following duct services:
  - 1. Indoor, concealed supply and outdoor air.
  - 2. Indoor, exposed supply and outdoor air.
  - 3. Indoor, concealed return located in unconditioned space.
  - 4. Indoor, exposed return located in unconditioned space.
- B. Related Sections:
  - 1. Section 230716 "HVAC Equipment Insulation."
  - 2. Section 230719 "HVAC Piping Insulation."
  - 3. Section 233113 "Metal Ducts" for duct liners.

## 1.3 ACTION SUBMITTALS

- A. Product Data: For each type of product indicated. Include thermal conductivity, water-vapor permeance thickness, and jackets (both factory- and field-applied if any).
- B. Shop Drawings: Include plans, elevations, sections, details, and attachments to other work.
  - 1. Detail application of protective shields, saddles, and inserts at hangers for each type of insulation and hanger.
  - 2. Detail insulation application at elbows, fittings, dampers, specialties and flanges for each type of insulation.
  - 3. Detail application of field-applied jackets.
  - 4. Detail application at linkages of control devices.

## 1.4 INFORMATIONAL SUBMITTALS

- A. Qualification Data: For qualified Installer.
- B. Material Test Reports: From a qualified testing agency acceptable to authorities having jurisdiction indicating, interpreting, and certifying test results for compliance of insulation materials, sealers, attachments, cements, and jackets, with requirements indicated. Include dates of tests and test methods employed.

- C. Field quality-control reports.

#### 1.5 QUALITY ASSURANCE

- A. Installer Qualifications: Skilled mechanics who have successfully completed an apprenticeship program or another craft training program certified by the Department of Labor, Bureau of Apprenticeship and Training.
- B. Surface-Burning Characteristics: For insulation and related materials, as determined by testing identical products according to ASTM E 84, by a testing agency acceptable to authorities having jurisdiction. Factory label insulation and jacket materials and adhesive, mastic, tapes, and cement material containers, with appropriate markings of applicable testing agency.
  - 1. Insulation Installed Indoors: Flame-spread index of 25 or less, and smoke-developed index of 50 or less.
  - 2. Insulation Installed Outdoors: Flame-spread index of 75 or less, and smoke-developed index of 150 or less.

#### 1.6 DELIVERY, STORAGE, AND HANDLING

- A. Packaging: Insulation material containers shall be marked by manufacturer with appropriate ASTM standard designation, type and grade, and maximum use temperature.

#### 1.7 COORDINATION

- A. Coordinate sizes and locations of supports, hangers, and insulation shields specified in Section 23 0529 "Hangers and Supports for HVAC Piping and Equipment."
- B. Coordinate clearance requirements with duct Installer for duct insulation application. Before preparing ductwork Shop Drawings, establish and maintain clearance requirements for installation of insulation and field-applied jackets and finishes and for space required for maintenance.
- C. Coordinate installation and testing of heat tracing.

#### 1.8 SCHEDULING

- A. Schedule insulation application after pressure testing systems and, where required, after installing and testing heat tracing. Insulation application may begin on segments that have satisfactory test results.
- B. Complete installation and concealment of plastic materials as rapidly as possible in each area of construction.

## PART 2 - PRODUCTS

## 2.1 INSULATION MATERIALS

- A. Comply with requirements in "Duct Insulation Schedule, General," "Indoor Duct and Plenum Insulation Schedule," and "Aboveground, Outdoor Duct and Plenum Insulation Schedule" articles for where insulating materials shall be applied.
- B. Products shall not contain asbestos, lead, mercury, or mercury compounds.
- C. Products that come in contact with stainless steel shall have a leachable chloride content of less than 50 ppm when tested according to ASTM C 871.
- D. Insulation materials for use on austenitic stainless steel shall be qualified as acceptable according to ASTM C 795.
- E. Foam insulation materials shall not use CFC or HCFC blowing agents in the manufacturing process.
- F. Flexible Elastomeric Insulation: Closed-cell, sponge- or expanded-rubber materials. Comply with ASTM C 534, Type II for sheet materials.
  - 1. Products: Subject to compliance with requirements, provide one of the following:
    - a. Aeroflex USA, Inc.; Aerocel.
    - b. Armacell LLC; AP Armaflex.
    - c. K-Flex USA; Insul-Sheet, K-Flex Gray Duct Liner, and K-FLEX LS.
- G. Mineral-Fiber Blanket Insulation: Mineral or glass fibers bonded with a thermosetting resin. Comply with ASTM C 553, Type II and ASTM C 1290, Type III with factory-applied FSK jacket. Factory-applied jacket requirements are specified in "Factory-Applied Jackets" Article.
  - 1. Products: Subject to compliance with requirements, provide one of the following:
    - a. CertainTeed Corp.; SoftTouch Duct Wrap.
    - b. Johns Manville; Microlite.
    - c. Knauf Insulation; Friendly Feel Duct Wrap.
    - d. Manson Insulation Inc.; Alley Wrap.
    - e. Owens Corning; SOFTR All-Service Duct Wrap.
- H. Mineral-Fiber Board Insulation: Mineral or glass fibers bonded with a thermosetting resin. Comply with ASTM C 612, Type IA or Type IB. For duct and plenum applications, provide insulation with factory-applied ASJ. Factory-applied jacket requirements are specified in "Factory-Applied Jackets" Article.
  - 1. Products: Subject to compliance with requirements, provide one of the following:
    - a. CertainTeed Corp.; Commercial Board.
    - b. Fibrex Insulations Inc.; FBX.
    - c. Johns Manville; 800 Series Spin-Glas.

- d. Knauf Insulation; Insulation Board.
  - e. Manson Insulation Inc.; AK Board.
  - f. Owens Corning; Fiberglas 700 Series.
- i. Polyolefin: Unicellular, polyethylene thermal plastic insulation. Comply with ASTM C 534 or ASTM C 1427, Type I, Grade 1 for tubular materials and Type II, Grade 1 for sheet materials.
- 1. Products: Subject to compliance with requirements, provide one of the following:
    - a. Armacell LLC; Tubolit.
    - b. Nomaco Insulation; IMCOLOCK, IMCOSHEET, NOMALOCK, and NOMAPLY.

## 2.2 FIRE-RATED INSULATION SYSTEMS

- A. Fire-Rated Board: Structural-grade, press-molded, xonolite calcium silicate, fireproofing board suitable for operating temperatures up to 1700 deg F. Comply with ASTM C 656, Type II, Grade 6. Tested and certified to provide a:
- a. 2-hour fire rating by an NRTL acceptable to authorities having jurisdiction
1. Products: Subject to compliance with requirements, provide the following :
- a. Johns Manville; Super Firetemp M.
- B. Fire-Rated Blanket: High-temperature, flexible, blanket insulation with FSK jacket that is tested and certified to provide a:
- a. 2-hour fire rating by an NRTL acceptable to authorities
1. Products: Subject to compliance with requirements, provide one of the following :
- a. CertainTeed Corp.; FlameChek.
  - b. Johns Manville; Firetemp Wrap.
  - c. Nelson Fire Stop Products; Nelson FSB Flameshield Blanket.
  - d. Thermal Ceramics; FireMaster Duct Wrap.
  - e. 3M; Fire Barrier Wrap Products.
  - f. Unifrax Corporation; FyreWrap.

## 2.3 ADHESIVES

- A. Materials shall be compatible with insulation materials, jackets, and substrates and for bonding insulation to itself and to surfaces to be insulated unless otherwise indicated.
- B. Flexible Elastomeric and Polyolefin Adhesive: Comply with MIL-A-24179A, Type II, Class I.
1. Products: Subject to compliance with requirements, provide one of the following:
- a. Aeroflex USA, Inc.; Aeroseal.
  - b. Armacell LLC; Armaflex 520 Adhesive.



- c. Foster Brand, Specialty Construction Brands, Inc., a business of H. B. Fuller Company; 85-75.
      - d. K-Flex USA; R-373 Contact Adhesive.
    2. For indoor applications, adhesive shall have a VOC content of 50 g/L or less when calculated according to 40 CFR 59, Subpart D (EPA Method 24).
  - C. Mineral-Fiber Adhesive: Comply with MIL-A-3316C, Class 2, Grade A.
    1. Products: Subject to compliance with requirements, provide one of the following:
      - a. Childers Brand, Specialty Construction Brands, Inc., a business of H. B. Fuller Company; CP-127.
      - b. Eagle Bridges - Marathon Industries; 225.
      - c. Foster Brand, Specialty Construction Brands, Inc., a business of H. B. Fuller Company; 85-60/85-70.
      - d. Mon-Eco Industries, Inc.; 22-25.
    2. For indoor applications, adhesive shall have a VOC content of 80 g/L or less when calculated according to 40 CFR 59, Subpart D (EPA Method 24).
  - D. FSK Jacket Adhesive, and ASJ Adhesive: Comply with MIL-A-3316C, Class 2, Grade A for bonding insulation jacket lap seams and joints.
    1. Products: Subject to compliance with requirements, provide one of the following:
      - a. Childers Brand, Specialty Construction Brands, Inc., a business of H. B. Fuller Company; CP-82.
      - b. Eagle Bridges - Marathon Industries; 225.
      - c. Foster Brand, Specialty Construction Brands, Inc., a business of H. B. Fuller Company; 85-50.
      - d. Mon-Eco Industries, Inc.; 22-25.
    2. For indoor applications, adhesive shall have a VOC content of 50 g/L or less when calculated according to 40 CFR 59, Subpart D (EPA Method 24).
- 2.4 MASTICS
- A. Materials shall be compatible with insulation materials, jackets, and substrates; comply with MIL-PRF-19565C, Type II.
    1. For indoor applications, use mastics that have a VOC content of 50 g/L or less when calculated according to 40 CFR 59, Subpart D (EPA Method 24).
  - B. Vapor-Barrier Mastic: Water based; suitable for indoor use on below ambient services.
    1. Products: Subject to compliance with requirements, provide one of the following:
      - a. Foster Brand, Specialty Construction Brands, Inc., a business of H. B. Fuller Company; 30-80/30-90.
      - b. Vimasco Corporation; 749.

2. Water-Vapor Permeance: ASTM E 96/E 96M, Procedure B, 0.013 perm at 43-mil dry film thickness.
  3. Service Temperature Range: Minus 20 to plus 180 deg F.
  4. Solids Content: ASTM D 1644, 58 percent by volume and 70 percent by weight.
  5. Color: White.
- C. Breather Mastic: Water based; suitable for indoor and outdoor use on above ambient services.
1. Products: Subject to compliance with requirements, provide one of the following:
    - a. Childers Brand, Specialty Construction Brands, Inc., a business of H. B. Fuller Company; CP-10.
    - b. Eagle Bridges - Marathon Industries; 550.
    - c. Foster Brand, Specialty Construction Brands, Inc., a business of H. B. Fuller Company; 46-50.
    - d. Mon-Eco Industries, Inc.; 55-50.
    - e. Vimasco Corporation; WC-1/WC-5.
  2. Water-Vapor Permeance: ASTM F 1249, 1.8 perms at 0.0625-inch dry film thickness.
  3. Service Temperature Range: Minus 20 to plus 180 deg F.
  4. Solids Content: 60 percent by volume and 66 percent by weight.
  5. Color: White.

## 2.5 LAGGING ADHESIVES

- A. Description: Comply with MIL-A-3316C, Class I, Grade A and shall be compatible with insulation materials, jackets, and substrates.
1. For indoor applications, use lagging adhesives that have a VOC content of 50 g/L or less when calculated according to 40 CFR 59, Subpart D (EPA Method 24).
  2. Products: Subject to compliance with requirements, provide one of the following:
    - a. Childers Brand, Specialty Construction Brands, Inc., a business of H. B. Fuller Company; CP-50 AHV2.
    - b. Foster Brand, Specialty Construction Brands, Inc., a business of H. B. Fuller Company; 30-36.
    - c. Vimasco Corporation; 713 and 714.
  3. Fire-resistant, water-based lagging adhesive and coating for use indoors to adhere fire-resistant lagging cloths over duct insulation.
  4. Service Temperature Range: 0 to plus 180 deg F.
  5. Color: White.

## 2.6 SEALANTS

- A. FSK and Metal Jacket Flashing Sealants:
1. Products: Subject to compliance with requirements, provide one of the following:

- a. Childers Brand, Specialty Construction Brands, Inc., a business of H. B. Fuller Company; CP-76.
  - b. Eagle Bridges - Marathon Industries; 405.
  - c. Foster Brand, Specialty Construction Brands, Inc., a business of H. B. Fuller Company; 95-44.
  - d. Mon-Eco Industries, Inc.; 44-05.
2. Materials shall be compatible with insulation materials, jackets, and substrates.
  3. Fire- and water-resistant, flexible, elastomeric sealant.
  4. Service Temperature Range: Minus 40 to plus 250 deg F.
  5. Color: Aluminum.
  6. For indoor applications, sealants shall have a VOC content of 420 g/L or less when calculated according to 40 CFR 59, Subpart D (EPA Method 24).

## 2.7 FACTORY-APPLIED JACKETS

- A. Insulation system schedules indicate factory-applied jackets on various applications. When factory-applied jackets are indicated, comply with the following:
  1. FSK Jacket: Aluminum-foil, fiberglass-reinforced scrim with kraft-paper backing; complying with ASTM C 1136, Type II.

## 2.8 FIELD-APPLIED JACKETS

- A. Field-applied jackets shall comply with ASTM C 921, Type I, unless otherwise indicated.
- B. FSK Jacket: Aluminum-foil-face, fiberglass-reinforced scrim with kraft-paper backing.
- C. Metal Jacket:
  1. Products: Subject to compliance with requirements, provide one of the following:
    - a. Childers Brand, Specialty Construction Brands, Inc., a business of H. B. Fuller Company; Metal Jacketing Systems.
    - b. ITW Insulation Systems; Aluminum and Stainless Steel Jacketing.
    - c. RPR Products, Inc.; Insul-Mate.
  2. Aluminum Jacket: Comply with ASTM B 209, Alloy 3003, 3005, 3105, or 5005, Temper H-14.
    - a. Sheet and roll stock ready for shop or field sizing
    - b. Finish and thickness are indicated in field-applied jacket schedules.
    - c. Moisture Barrier for Indoor Applications: 3-mil-thick, heat-bonded polyethylene and kraft paper.
    - d. Moisture Barrier for Outdoor Applications: 3-mil-thick, heat-bonded polyethylene and kraft.

## 2.9 TAPES

- A. FSK Tape: Foil-face, vapor-retarder tape matching factory-applied jacket with acrylic adhesive; complying with ASTM C 1136.
1. Products: Subject to compliance with requirements, provide one of the following:
    - a. ABI, Ideal Tape Division; 491 AWF FSK.
    - b. Avery Dennison Corporation, Specialty Tapes Division; Fasson 0827.
    - c. Compac Corporation; 110 and 111.
    - d. Venture Tape; 1525 CW NT, 1528 CW, and 1528 CW/SQ.
  2. Width: 3 inches.
  3. Thickness: 6.5 mils.
  4. Adhesion: 90 ounces force/inch in width.
  5. Elongation: 2 percent.
  6. Tensile Strength: 40 lbf/inch in width.
  7. FSK Tape Disks and Squares: Precut disks or squares of FSK tape.
- B. Aluminum-Foil Tape: Vapor-retarder tape with acrylic adhesive.
1. Products: Subject to compliance with requirements, provide one of the following:
    - a. ABI, Ideal Tape Division; 488 AWF.
    - b. Avery Dennison Corporation, Specialty Tapes Division; Fasson 0800.
    - c. Compac Corporation; 120.
    - d. Venture Tape; 3520 CW.
  2. Width: 2 inches.
  3. Thickness: 3.7 mils.
  4. Adhesion: 100 ounces force/inch in width.
  5. Elongation: 5 percent.
  6. Tensile Strength: 34 lbf/inch in width.

## 2.10 SECUREMENTS

- A. Bands:
1. Products: Subject to compliance with requirements, provide one of the following:
    - a. ITW Insulation Systems; Gerrard Strapping and Seals.
    - b. RPR Products, Inc.; Insul-Mate Strapping, Seals, and Springs.
  2. Aluminum: ASTM B 209, Alloy 3003, 3005, 3105, or 5005; Temper H-14, 0.020 inch thick, 3/4 inch wide with wing seal.
  3. Springs: Twin spring set constructed of stainless steel with ends flat and slotted to accept metal bands. Spring size determined by manufacturer for application.
- B. Insulation Pins and Hangers:
1. Capacitor-Discharge-Weld Pins: Copper- or zinc-coated steel pin, fully annealed for capacitor-discharge welding, 0.135-inch-diameter shank, length to suit depth of insulation indicated.

- a. Products: Subject to compliance with requirements, provide one of the following:
  - 1) AGM Industries, Inc.; CWP-1.
  - 2) GEMCO; CD.
  - 3) Midwest Fasteners, Inc.; CD.
  - 4) Nelson Stud Welding; TPA, TPC, and TPS.
2. Cupped-Head, Capacitor-Discharge-Weld Pins: Copper- or zinc-coated steel pin, fully annealed for capacitor-discharge welding, 0.135-inch- diameter shank, length to suit depth of insulation indicated with integral 1-1/2-inch galvanized carbon-steel washer.
  - a. Products: Subject to compliance with requirements, provide one of the following:
    - 1) AGM Industries, Inc.; CHP-1.
    - 2) GEMCO; Cupped Head Weld Pin.
    - 3) Midwest Fasteners, Inc.; Cupped Head.
    - 4) Nelson Stud Welding; CHP.
3. Metal, Adhesively Attached, Perforated-Base Insulation Hangers: Baseplate welded to projecting spindle that is capable of holding insulation, of thickness indicated, securely in position indicated when self-locking washer is in place. Comply with the following requirements:
  - a. Products: Subject to compliance with requirements, provide one of the following:
    - 1) AGM Industries, Inc.; Tactoo Perforated Base Insul-Hangers.
    - 2) GEMCO; Perforated Base.
    - 3) Midwest Fasteners, Inc.; Spindle.
  - b. Baseplate: Perforated, galvanized carbon-steel sheet, 0.030 inch thick by 2 inches square.
  - c. Spindle: Copper- or zinc-coated, low-carbon steel fully annealed, 0.106-inch- diameter shank, length to suit depth of insulation indicated.
  - d. Adhesive: Recommended by hanger manufacturer. Product with demonstrated capability to bond insulation hanger securely to substrates indicated without damaging insulation, hangers, and substrates.
4. Nonmetal, Adhesively Attached, Perforated-Base Insulation Hangers: Baseplate fastened to projecting spindle that is capable of holding insulation, of thickness indicated, securely in position indicated when self-locking washer is in place. Comply with the following requirements:
  - a. Products: Subject to compliance with requirements, provide one of the following:
    - 1) GEMCO; Nylon Hangers.
    - 2) Midwest Fasteners, Inc.; Nylon Insulation Hangers.

- b. Baseplate: Perforated, nylon sheet, 0.030 inch thick by 1-1/2 inches in diameter.
  - c. Spindle: Nylon, 0.106-inch- diameter shank, length to suit depth of insulation indicated, up to 2-1/2 inches.
  - d. Adhesive: Recommended by hanger manufacturer. Product with demonstrated capability to bond insulation hanger securely to substrates indicated without damaging insulation, hangers, and substrates.
5. Self-Sticking-Base Insulation Hangers: Baseplate welded to projecting spindle that is capable of holding insulation, of thickness indicated, securely in position indicated when self-locking washer is in place. Comply with the following requirements:
- a. Products: Subject to compliance with requirements, provide one of the following:
    - 1) AGM Industries, Inc.; Tactoo Self-Adhering Insul-Hangers.
    - 2) GEMCO; Peel & Press.
    - 3) Midwest Fasteners, Inc.; Self Stick.
  - b. Baseplate: Galvanized carbon-steel sheet, 0.030 inch thick by 2 inches square.
  - c. Spindle: Copper- or zinc-coated, low-carbon steel, fully annealed, 0.106-inch- diameter shank, length to suit depth of insulation indicated.
  - d. Adhesive-backed base with a peel-off protective cover.

### PART 3 - EXECUTION

#### 3.1 EXAMINATION

- A. Examine substrates and conditions for compliance with requirements for installation tolerances and other conditions affecting performance of insulation application.
  - 1. Verify that systems to be insulated have been tested and are free of defects.
  - 2. Verify that surfaces to be insulated are clean and dry.
- B. Proceed with installation only after unsatisfactory conditions have been corrected.

#### 3.2 PREPARATION

- A. Surface Preparation: Clean and dry surfaces to receive insulation. Remove materials that will adversely affect insulation application.

#### 3.3 GENERAL INSTALLATION REQUIREMENTS

- A. Install insulation materials, accessories, and finishes with smooth, straight, and even surfaces; free of voids throughout the length of ducts and fittings.

- B. Install insulation materials, vapor barriers or retarders, jackets, and thicknesses required for each item of duct system as specified in insulation system schedules.
- C. Install accessories compatible with insulation materials and suitable for the service. Install accessories that do not corrode, soften, or otherwise attack insulation or jacket in either wet or dry state.
- D. Install insulation with longitudinal seams at top and bottom of horizontal runs.
- E. Install multiple layers of insulation with longitudinal and end seams staggered.
- F. Keep insulation materials dry during application and finishing.
- G. Install insulation with tight longitudinal seams and end joints. Bond seams and joints with adhesive recommended by insulation material manufacturer.
- H. Install insulation with least number of joints practical.
- I. Where vapor barrier is indicated, seal joints, seams, and penetrations in insulation at hangers, supports, anchors, and other projections with vapor-barrier mastic.
  - 1. Install insulation continuously through hangers and around anchor attachments.
  - 2. For insulation application where vapor barriers are indicated, extend insulation on anchor legs from point of attachment to supported item to point of attachment to structure. Taper and seal ends at attachment to structure with vapor-barrier mastic.
  - 3. Install insert materials and install insulation to tightly join the insert. Seal insulation to insulation inserts with adhesive or sealing compound recommended by insulation material manufacturer.
- J. Apply adhesives, mastics, and sealants at manufacturer's recommended coverage rate and wet and dry film thicknesses.
- K. Install insulation with factory-applied jackets as follows:
  - 1. Draw jacket tight and smooth.
  - 2. Cover circumferential joints with 3-inch- wide strips, of same material as insulation jacket. Secure strips with adhesive and outward clinching staples along both edges of strip, spaced 4 inches o.c.
  - 3. Overlap jacket longitudinal seams at least 1-1/2 inches. Clean and dry surface to receive self-sealing lap. Staple laps with outward clinching staples along edge at:
    - a. 2 inche o.c.
    - b. For below ambient services, apply vapor-barrier mastic over staples.
  - 4. Cover joints and seams with tape, according to insulation material manufacturer's written instructions, to maintain vapor seal.
  - 5. Where vapor barriers are indicated, apply vapor-barrier mastic on seams and joints and at ends adjacent to duct flanges and fittings.
- L. Cut insulation in a manner to avoid compressing insulation more than 75 percent of its nominal thickness.

- M. Finish installation with systems at operating conditions. Repair joint separations and cracking due to thermal movement.
- N. Repair damaged insulation facings by applying same facing material over damaged areas. Extend patches at least 4 inches beyond damaged areas. Adhere, staple, and seal patches similar to butt joints.

### 3.4 PENETRATIONS

- A. Insulation Installation at Roof Penetrations: Install insulation continuously through roof penetrations.
  - 1. Seal penetrations with flashing sealant.
  - 2. For applications requiring only indoor insulation, terminate insulation above roof surface and seal with joint sealant. For applications requiring indoor and outdoor insulation, install insulation for outdoor applications tightly joined to indoor insulation ends. Seal joint with joint sealant.
  - 3. Extend jacket of outdoor insulation outside roof flashing at least 2 inches below top of roof flashing.
  - 4. Seal jacket to roof flashing with flashing sealant.
- B. Insulation Installation at Aboveground Exterior Wall Penetrations: Install insulation continuously through wall penetrations.
  - 1. Seal penetrations with flashing sealant.
  - 2. For applications requiring only indoor insulation, terminate insulation inside wall surface and seal with joint sealant. For applications requiring indoor and outdoor insulation, install insulation for outdoor applications tightly joined to indoor insulation ends. Seal joint with joint sealant.
  - 3. Extend jacket of outdoor insulation outside wall flashing and overlap wall flashing at least 2 inches.
  - 4. Seal jacket to wall flashing with flashing sealant.
- C. Insulation Installation at Interior Wall and Partition Penetrations (That Are Not Fire Rated): Install insulation continuously through walls and partitions.
- D. Insulation Installation at Fire-Rated Wall and Partition Penetrations: Terminate insulation at fire damper sleeves for fire-rated wall and partition penetrations. Externally insulate damper sleeves to match adjacent insulation and overlap duct insulation at least 2 inches.
  - 1. Comply with requirements in Section 078413 "Penetration Firestopping" firestopping and fire-resistive joint sealers.
- E. Insulation Installation at Floor Penetrations:
  - 1. Duct: For penetrations through fire-rated assemblies, terminate insulation at fire damper sleeves and externally insulate damper sleeve beyond floor to match adjacent duct insulation. Overlap damper sleeve and duct insulation at least 2 inches.
  - 2. Seal penetrations through fire-rated assemblies. Comply with requirements in Section 078413 "Penetration Firestopping."



## 3.5 INSTALLATION OF FLEXIBLE ELASTOMERIC INSULATION

- A. Seal longitudinal seams and end joints with manufacturer's recommended adhesive to eliminate openings in insulation that allow passage of air to surface being insulated.

## 3.6 INSTALLATION OF MINERAL-FIBER INSULATION

- A. Blanket Insulation Installation on Ducts and Plenums: Secure with adhesive and insulation pins.
  - 1. Apply adhesives according to manufacturer's recommended coverage rates per unit area, for:
    - a. 100 percent coverage of duct and plenum surfaces.
  - 2. Apply adhesive to entire circumference of ducts and to all surfaces of fittings and transitions.
  - 3. Install either capacitor-discharge-weld pins and speed washers or cupped-head, capacitor-discharge-weld pins on sides and bottom of horizontal ducts and sides of vertical ducts as follows:
    - a. On duct sides with dimensions 18 inches and smaller, place pins along longitudinal centerline of duct. Space 3 inches maximum from insulation end joints, and 16 inches o.c.
    - b. On duct sides with dimensions larger than 18 inches, place pins 16 inches o.c. each way, and 3 inches maximum from insulation joints. Install additional pins to hold insulation tightly against surface at cross bracing.
    - c. Pins may be omitted from top surface of horizontal, rectangular ducts and plenums.
    - d. Do not overcompress insulation during installation.
    - e. Impale insulation over pins and attach speed washers.
    - f. Cut excess portion of pins extending beyond speed washers or bend parallel with insulation surface. Cover exposed pins and washers with tape matching insulation facing.
  - 4. For ducts and plenums with surface temperatures below ambient, install a continuous unbroken vapor barrier. Create a facing lap for longitudinal seams and end joints with insulation by removing 2 inches from one edge and one end of insulation segment. Secure laps to adjacent insulation section with 1/2-inch outward-clinching staples, 1 inch o.c. Install vapor barrier consisting of factory- or field-applied jacket, adhesive, vapor-barrier mastic, and sealant at joints, seams, and protrusions.
    - a. Repair punctures, tears, and penetrations with tape or mastic to maintain vapor-barrier seal.
    - b. Install vapor stops for ductwork and plenums operating below 50 deg F at 18-foot intervals. Vapor stops shall consist of vapor-barrier mastic applied in a Z-shaped pattern over insulation face, along butt end of insulation, and over the surface. Cover insulation face and surface to be insulated a width equal to two times the insulation thickness, but not less than 3 inches.
  - 5. Overlap unfaced blankets a minimum of 2 inches on longitudinal seams and end joints. At end joints, secure with steel bands spaced a maximum of 18 inches o.c.

6. Install insulation on rectangular duct elbows and transitions with a full insulation section for each surface. Install insulation on round and flat-oval duct elbows with individually mitered gores cut to fit the elbow.
  7. Insulate duct stiffeners, hangers, and flanges that protrude beyond insulation surface with 6-inch- wide strips of same material used to insulate duct. Secure on alternating sides of stiffener, hanger, and flange with pins spaced 6 inches o.c.
- B. Board Insulation Installation on Ducts and Plenums: Secure with adhesive and insulation pins.
1. Apply adhesives according to manufacturer's recommended coverage rates per unit area, for:
    - a. 50 percent coverage of duct and plenum surfaces.
  2. Apply adhesive to entire circumference of ducts and to all surfaces of fittings and transitions.
  3. Install either capacitor-discharge-weld pins and speed washers or cupped-head, capacitor-discharge-weld pins on sides and bottom of horizontal ducts and sides of vertical ducts as follows:
    - a. On duct sides with dimensions 18 inches and smaller, place pins along longitudinal centerline of duct. Space 3 inches maximum from insulation end joints, and 16 inches o.c.
    - b. On duct sides with dimensions larger than 18 inches, space pins 16 inches o.c. each way, and 3 inches maximum from insulation joints. Install additional pins to hold insulation tightly against surface at cross bracing.
    - c. Pins may be omitted from top surface of horizontal, rectangular ducts and plenums.
    - d. Do not overcompress insulation during installation.
    - e. Cut excess portion of pins extending beyond speed washers or bend parallel with insulation surface. Cover exposed pins and washers with tape matching insulation facing.
  4. For ducts and plenums with surface temperatures below ambient, install a continuous unbroken vapor barrier. Create a facing lap for longitudinal seams and end joints with insulation by removing 2 inches from one edge and one end of insulation segment. Secure laps to adjacent insulation section with 1/2-inch outward-clinching staples, 1 inch o.c. Install vapor barrier consisting of factory- or field-applied jacket, adhesive, vapor-barrier mastic, and sealant at joints, seams, and protrusions.
    - a. Repair punctures, tears, and penetrations with tape or mastic to maintain vapor-barrier seal.
  5. Install insulation on rectangular duct elbows and transitions with a full insulation section for each surface. Groove and score insulation to fit as closely as possible to outside and inside radius of elbows. Install insulation on round and flat-oval duct elbows with individually mitered gores cut to fit the elbow.
  6. Insulate duct stiffeners, hangers, and flanges that protrude beyond insulation surface with 6-inch- wide strips of same material used to insulate duct. Secure on alternating sides of stiffener, hanger, and flange with pins spaced 6 inches o.c.

### 3.7 FIELD-APPLIED JACKET INSTALLATION

- A. Where glass-cloth jackets are indicated, install directly over bare insulation or insulation with factory-applied jackets.
1. Draw jacket smooth and tight to surface with 2-inch overlap at seams and joints.
  2. Embed glass cloth between two 0.062-inch- thick coats of lagging adhesive.
  3. Completely encapsulate insulation with coating, leaving no exposed insulation.
- B. Where FSK jackets are indicated, install as follows:
1. Draw jacket material smooth and tight.
  2. Install lap or joint strips with same material as jacket.
  3. Secure jacket to insulation with manufacturer's recommended adhesive.
  4. Install jacket with 1-1/2-inch laps at longitudinal seams and 3-inch- wide joint strips at end joints.
  5. Seal openings, punctures, and breaks in vapor-retarder jackets and exposed insulation with vapor-barrier mastic.
- C. Where PVC jackets are indicated, install with 1-inch overlap at longitudinal seams and end joints; for horizontal applications, install with longitudinal seams along top and bottom of tanks and vessels. Seal with manufacturers recommended adhesive.
1. Apply two continuous beads of adhesive to seams and joints, one bead under lap and the finish bead along seam and joint edge.
- D. Where metal jackets are indicated, install with 2-inch overlap at longitudinal seams and end joints. Overlap longitudinal seams arranged to shed water. Seal end joints with weatherproof sealant recommended by insulation manufacturer. Secure jacket with stainless-steel bands 12 inches o.c. and at end joints.

### 3.8 FIRE-RATED INSULATION SYSTEM INSTALLATION

- A. Where fire-rated insulation system is indicated, secure system to ducts and duct hangers and supports to maintain a continuous fire rating.
- B. Insulate duct access panels and doors to achieve same fire rating as duct.
- C. Install firestopping at penetrations through fire-rated assemblies. Fire-stop systems are specified in Section 078413 "Penetration Firestopping."

### 3.9 FINISHES

- A. Insulation with ASJ, Glass-Cloth, or Other Paintable Jacket Material: Paint jacket with paint system identified below and as specified in Section 099113 "Exterior Painting" and Section 09 9123 "Interior Painting."
1. Flat Acrylic Finish: Two finish coats over a primer that is compatible with jacket material and finish coat paint. Add fungicidal agent to render fabric mildew proof.

- a. Finish Coat Material: Interior, flat, latex-emulsion size.
- B. Flexible Elastomeric Thermal Insulation: After adhesive has fully cured, apply two coats of insulation manufacturer's recommended protective coating.
- C. Color: Final color as selected by Architect. Vary first and second coats to allow visual inspection of the completed Work.
- D. Do not field paint aluminum or stainless-steel jackets.

### 3.10 FIELD QUALITY CONTROL

- A. Testing Agency:
  - a. Engage a qualified testing agency to perform tests and inspections.
- B. Perform tests and inspections.
- C. Tests and Inspections:
  - 1. Inspect ductwork, randomly selected by Architect, by removing field-applied jacket and insulation in layers in reverse order of their installation. Extent of inspection shall be limited to one location (s) for each duct system defined in the "Duct Insulation Schedule, General" Article.
- D. All insulation applications will be considered defective Work if sample inspection reveals noncompliance with requirements.

### 3.11 DUCT INSULATION SCHEDULE, GENERAL

- A. Plenums and Ducts Requiring Insulation:
  - 1. Indoor, concealed supply and outdoor air.
  - 2. Indoor, exposed supply and outdoor air.
  - 3. Indoor, concealed return located in unconditioned space.
  - 4. Indoor, exposed return located in unconditioned space.
- B. Items Not Insulated:
  - 1. Fibrous-glass ducts.
  - 2. Metal ducts with duct liner of sufficient thickness to comply with energy code and ASHRAE/IESNA 90.1.
  - 3. Factory-insulated flexible ducts.
  - 4. Factory-insulated plenums and casings.
  - 5. Flexible connectors.
  - 6. Vibration-control devices.
  - 7. Factory-insulated access panels and doors.

3.12 Insulation shall have an R value that meets the minimum requirements of the latest International Energy Conservation Code (IECC).

3.13 INDOOR DUCT AND PLENUM INSULATION SCHEDULE

- A. Concealed, round and flat-oval, supply-air duct insulation shall be one of the following:
1. Flexible Elastomeric: 1 inch thick.
  2. Mineral-Fiber Blanket: 2 inches thick and 0.75-lb/cu. ft. nominal density.
- B. Concealed, round and flat-oval, return-air duct insulation shall be one of the following:
1. Flexible Elastomeric: 1 inch thick.
  2. Mineral-Fiber Blanket: 2 inches thick and 0.75-lb/cu. ft. nominal density.
- C. Concealed, round and flat-oval, outdoor-air and combustion-air duct insulation shall be one of the following:
1. Flexible Elastomeric: 1 inch thick.
  2. Mineral-Fiber Blanket: 2 inches thick and 0.75-lb/cu. ft. nominal density.
- D. Concealed, round and flat-oval, exhaust-air duct insulation shall be one of the following:
1. Flexible Elastomeric: 1 inch thick.
  2. Mineral-Fiber Blanket: 2 inches thick and 0.75-lb/cu. ft. nominal density.
- E. Concealed, rectangular, supply-air duct insulation shall be one of the following:
1. Flexible Elastomeric: 1 inch thick.
  2. Mineral-Fiber Blanket: 2 inches thick and 0.75-lb/cu. ft. nominal density.
- F. Concealed, rectangular, return-air duct insulation shall be one of the following:
1. Flexible Elastomeric: 1 inch thick.
  2. Mineral-Fiber Blanket: 2 inches thick and 0.75-lb/cu. ft. nominal density.
- G. Concealed, rectangular, outdoor-air and combustion-air duct insulation shall be one of the following:
1. Flexible Elastomeric: 1 inch thick.
  2. Mineral-Fiber Blanket: 2 inches thick and 0.75-lb/cu. ft. nominal density.
- H. Concealed, supply-air plenum insulation shall be one of the following:
1. Flexible Elastomeric: 1 inch thick.
  2. Mineral-Fiber Blanket: 2 inches thick and 0.75-lb/cu. ft. nominal density.
- I. Concealed, return-air plenum insulation shall be one of the following:
1. Flexible Elastomeric: 1 inch thick.
  2. Mineral-Fiber Blanket: 2 inches thick and 0.75-lb/cu. ft. nominal density.

- J. Concealed, outdoor-air plenum insulation shall be one of the following:
1. Flexible Elastomeric: 1 inch thick.
  2. Mineral-Fiber Blanket: 2 inches thick and 0.75-lb/cu. ft. nominal density.
- K. Exposed, round and flat-oval, supply-air duct insulation shall be one of the following:
1. Flexible Elastomeric: 1 inch thick.
  2. Mineral-Fiber Blanket: 2 inches thick and 0.75-lb/cu. ft. nominal density.
- L. Exposed, round and flat-oval, return-air duct insulation shall be one of the following:
1. Flexible Elastomeric: 1 inch thick.
  2. Mineral-Fiber Blanket: 2 inches thick and 0.75-lb/cu. ft. nominal density.
- M. Exposed, round and flat-oval, outdoor-air and combustion-air duct insulation shall be one of the following:
1. Flexible Elastomeric: 1 inch thick.
  2. Mineral-Fiber Blanket: 2 inches thick and 0.75-lb/cu. ft. nominal density.
- N. Exposed, rectangular, supply-air duct insulation shall be one of the following:
1. Flexible Elastomeric: 1 inch thick.
  2. Mineral-Fiber Blanket: 2 inches thick and 0.75-lb/cu. ft. nominal density.
- O. Exposed, rectangular, return-air duct insulation shall be one of the following:
1. Flexible Elastomeric: 1 inch thick.
  2. Mineral-Fiber Blanket: 2 inches thick and 0.75-lb/cu. ft. nominal density.
- P. Exposed, supply-air plenum insulation shall be one of the following:
1. Flexible Elastomeric: 1 inch thick.
  2. Mineral-Fiber Blanket: 2 inches thick and 0.75-lb/cu. ft. nominal density.
- Q. Exposed, return-air plenum insulation shall be one of the following:
1. Flexible Elastomeric: 1 inch thick.
  2. Mineral-Fiber Blanket: 2 inches thick and 0.75-lb/cu. ft. nominal density.

END OF SECTION

**SECTION 23 0 19 - HVAC PIPING INSULATION**

## PART 1 - GENERAL

## 1.1 RELATED DOCUMENTS

- A. Drawings and general provisions of the Contract, including General and Supplementary Conditions and Division 01 Specification Sections, apply to this Section.

## 1.2 SUMMARY

- A. Section includes insulating the following HVAC piping systems:

1. Chilled-water piping.
2. Heating hot-water piping.
3. Refrigerant suction and hot-gas piping.

- B. Related Sections:

1. Section 23 0713 "Duct Insulation."

## 1.3 DEFINITIONS:

- A. Refer to Section 23 0500 "Common Work Results for HVAC".

## 1.4 ACTION SUBMITTALS

- A. Product Data: For each type of product indicated. Include thermal conductivity, water-vapor permeance thickness, and jackets (both factory and field applied if any).
- B. Shop Drawings: Include plans, elevations, sections, details, and attachments to other work.
  1. Detail application of protective shields, saddles, and inserts at hangers for each type of insulation and hanger.
  2. Detail attachment and covering of heat tracing inside insulation.
  3. Detail insulation application at pipe expansion joints for each type of insulation.
  4. Detail insulation application at elbows, fittings, flanges, valves, and specialties for each type of insulation.
  5. Detail removable insulation at piping specialties.
  6. Detail application of field-applied jackets.
  7. Detail application at linkages of control devices.

## 1.5 INFORMATIONAL SUBMITTALS

- A. Qualification Data: For qualified Installer.

- B. Material Test Reports: From a qualified testing agency acceptable to authorities having jurisdiction indicating, interpreting, and certifying test results for compliance of insulation materials, sealers, attachments, cements, and jackets, with requirements indicated. Include dates of tests and test methods employed.

#### 1.6 QUALITY ASSURANCE

- A. Installer Qualifications: Skilled mechanics who have successfully completed an apprenticeship program or another craft training program certified by the Department of Labor, Bureau of Apprenticeship and Training.
- B. Surface-Burning Characteristics: For insulation and related materials, as determined by testing identical products according to ASTM E 84, by a testing and inspecting agency acceptable to authorities having jurisdiction. Factory label insulation and jacket materials and adhesive, mastic, tapes, and cement material containers, with appropriate markings of applicable testing agency.
  - 1. Insulation Installed Indoors: Flame-spread index of 25 or less, and smoke-developed index of 50 or less.
  - 2. Insulation Installed Outdoors: Flame-spread index of 75 or less, and smoke-developed index of 150 or less.

#### 1.7 DELIVERY, STORAGE, AND HANDLING

- A. Packaging: Insulation material containers shall be marked by manufacturer with appropriate ASTM standard designation, type and grade, and maximum use temperature.

#### 1.8 COORDINATION

- A. Coordinate sizes and locations of supports, hangers, and insulation shields specified in Section 23 0529 "Hangers and Supports for HVAC Piping and Equipment."
- B. Coordinate clearance requirements with piping Installer for piping insulation application. Before preparing piping Shop Drawings, establish and maintain clearance requirements for installation of insulation and field-applied jackets and finishes and for space required for maintenance.

#### 1.9 SCHEDULING

- A. Schedule insulation application after pressure testing systems and, where required, after installing and testing heat tracing. Insulation application may begin on segments that have satisfactory test results.
- B. Complete installation and concealment of plastic materials as rapidly as possible in each area of construction.



## PART 2 - PRODUCTS

## 2.1 INSULATION MATERIALS

- A. Comply with requirements in "Piping Insulation Schedule, General," "Indoor Piping Insulation Schedule," "Outdoor, Aboveground Piping Insulation Schedule," and "Outdoor, Underground Piping Insulation Schedule" articles for where insulating materials shall be applied.
- B. Insulation for below-ambient service requires a vapor-barrier.
- C. Products shall not contain asbestos, lead, mercury, or mercury compounds.
- D. Products that come in contact with stainless steel shall have a leachable chloride content of less than 50 ppm when tested according to ASTM C 871.
- E. Insulation materials for use on austenitic stainless steel shall be qualified as acceptable according to ASTM C 795.
- F. Foam insulation materials shall not use CFC or HCFC blowing agents in the manufacturing process.
- G. Calcium Silicate:
  - 1. Products: Subject to compliance with requirements, provide the following:
    - a. Industrial Insulation Group (IIG); Thermo-12 Gold.
  - 2. Preformed Pipe Sections: Flat-, curved-, and grooved-block sections of noncombustible, inorganic, hydrous calcium silicate with a non-asbestos fibrous reinforcement. Comply with ASTM C 533, Type I.
  - 3. Flat-, curved-, and grooved-block sections of noncombustible, inorganic, hydrous calcium silicate with a non-asbestos fibrous reinforcement. Comply with ASTM C 533, Type I.
  - 4. Prefabricated Fitting Covers: Comply with ASTM C 450 and ASTM C 585 for dimensions used in preforming insulation to cover valves, elbows, tees, and flanges.
- H. Flexible Elastomeric Insulation: Closed-cell, sponge- or expanded-rubber materials. Comply with ASTM C 534, Type I for tubular materials.
  - 1. Products: Subject to compliance with requirements, provide one of the following:
    - a. Aeroflex USA, Inc.; Aerocel.
    - b. Armacell LLC; AP Armaflex.
    - c. K-Flex USA; Insul-Lock, Insul-Tube, and K-FLEX LS.
- I. Mineral-Fiber Blanket Insulation: Mineral or glass fibers bonded with a thermosetting resin. Comply with ASTM C 553,
  - 1. Type II and ASTM C 1290, Factory-applied jacket requirements are specified in "Factory-Applied Jackets" Article.

2. Products: Subject to compliance with requirements, provide one of the following:
  - a. CertainTeed Corp.; SoftTouch Duct Wrap.
  - b. Johns Manville; Microlite.
  - c. Knauf Insulation; Friendly Feel Duct Wrap.
  - d. Manson Insulation Inc.; Alley Wrap.
  - e. Owens Corning; SOFTR All-Service Duct Wrap.
  
- J. Mineral-Fiber, Preformed Pipe Insulation:
  1. Products: Subject to compliance with requirements, provide one of the following:
    - a. Johns Manville; Micro-Lok.
    - b. Knauf Insulation; 1000-Degree Pipe Insulation.
    - c. Manson Insulation Inc.; Alley-K.
    - d. Owens Corning; Fiberglas Pipe Insulation.
    - e. Type I, 850 deg F Materials: Mineral or glass fibers bonded with a thermosetting resin. Comply with ASTM C 547, Type I, Grade A:
      - 1) with factory-applied ASJ-SSL. Factory-applied jacket requirements are specified in "Factory-Applied Jackets" Article.
  
- K. Mineral-Fiber, Pipe and Tank Insulation: Mineral or glass fibers bonded with a thermosetting resin. Semirigid board material with factory-applied:
  1. ASJ complying with ASTM C 1393, Type II or Type IIIA Category 2, or with properties similar to ASTM C 612, Type IB. Nominal density is 2.5 lb/cu. ft. or more. Thermal conductivity (k-value) at 100 deg F is 0.29 Btu x in./h x sq. ft. x deg F or less. Factory-applied jacket requirements are specified in "Factory-Applied Jackets" Article.
  
  2. Products: Subject to compliance with requirements, provide one of the following:
    - a. CertainTeed Corp.; CrimpWrap.
    - b. Johns Manville; MicroFlex.
    - c. Knauf Insulation; Pipe and Tank Insulation.
    - d. Manson Insulation Inc.; AK Flex.
    - e. Owens Corning; Fiberglas Pipe and Tank Insulation.
  
- L. Prefabricated Thermal Insulating Fitting Covers: Comply with ASTM C 450 for dimensions used in preforming insulation to cover valves, elbows, tees, and flanges.

## 2.2 INSULATING CEMENTS

- A. Mineral-Fiber Insulating Cement: Comply with ASTM C 195.
  1. Products: Subject to compliance with requirements, provide the following:
    - a. Ramco Insulation, Inc.; Super-Stik.
  
- B. Mineral-Fiber, Hydraulic-Setting Insulating and Finishing Cement: Comply with ASTM C 449.
  1. Products: Subject to compliance with requirements, provide the following:

- a. Ramco Insulation, Inc.; Ramcote 1200 and Quik-Cote.

## 2.3 ADHESIVES

- A. Materials shall be compatible with insulation materials, jackets, and substrates and for bonding insulation to itself and to surfaces to be insulated unless otherwise indicated.
- B. Calcium Silicate Adhesive: Fibrous, sodium-silicate-based adhesive with a service temperature range of 50 to 800 deg F.
  1. Products: Subject to compliance with requirements, provide one of the following:
    - a. Childers Brand, Specialty Construction Brands, Inc., a business of H. B. Fuller Company; CP-97.
    - b. Eagle Bridges - Marathon Industries; 290.
    - c. Foster Brand, Specialty Construction Brands, Inc., a business of H. B. Fuller Company; 81-27.
    - d. Mon-Eco Industries, Inc.; 22-30.
    - e. Vimasco Corporation; 760.
  2. For indoor applications, adhesive shall have a VOC content of 80 g/L or less when calculated according to 40 CFR 59, Subpart D (EPA Method 24).
- C. Flexible Elastomeric Adhesive: Comply with MIL-A-24179A, Type II, Class I.
  1. Products: Subject to compliance with requirements, provide one of the following:
    - a. Aeroflex USA, Inc.; Aeroseal.
    - b. Armacell LLC; Armaflex 520 Adhesive.
    - c. Foster Brand, Specialty Construction Brands, Inc., a business of H. B. Fuller Company; 85-75.
    - d. K-Flex USA; R-373 Contact Adhesive.
  2. For indoor applications, adhesive shall have a VOC content of 50 g/L or less when calculated according to 40 CFR 59, Subpart D (EPA Method 24).
- D. Mineral-Fiber Adhesive: Comply with MIL-A-3316C, Class 2, Grade A.
  1. Products: Subject to compliance with requirements, provide one of the following:
    - a. Childers Brand, Specialty Construction Brands, Inc., a business of H. B. Fuller Company; CP-127.
    - b. Eagle Bridges - Marathon Industries; 225.
    - c. Foster Brand, Specialty Construction Brands, Inc., a business of H. B. Fuller Company; 85-60/85-70.
    - d. Mon-Eco Industries, Inc.; 22-25.
  2. For indoor applications, adhesive shall have a VOC content of 80 g/L or less when calculated according to 40 CFR 59, Subpart D (EPA Method 24).
- E. ASJ Adhesive, and FSK Jacket Adhesive: Comply with MIL-A-3316C, Class 2, Grade A for bonding insulation jacket lap seams and joints.

1. Products: Subject to compliance with requirements, provide one of the following:
    - a. Childers Brand, Specialty Construction Brands, Inc., a business of H. B. Fuller Company; CP-82.
    - b. Eagle Bridges - Marathon Industries; 225.
    - c. Foster Brand, Specialty Construction Brands, Inc., a business of H. B. Fuller Company; 85-50.
    - d. Mon-Eco Industries, Inc.; 22-25.
  2. For indoor applications, adhesive shall have a VOC content of 50 g/L or less when calculated according to 40 CFR 59, Subpart D (EPA Method 24).
- F. PVC Jacket Adhesive: Compatible with PVC jacket.
1. Products: Subject to compliance with requirements, provide one of the following:
    - a. Dow Corning Corporation; 739, Dow Silicone.
    - b. Johns Manville; Zeston Perma-Weld, CEEL-TITE Solvent Welding Adhesive.
    - c. P.I.C. Plastics, Inc.; Welding Adhesive.
    - d. Speedline Corporation; Polyco VP Adhesive.
  2. For indoor applications, adhesive shall have a VOC content of 50 g/L or less when calculated according to 40 CFR 59, Subpart D (EPA Method 24).

## 2.4 MASTICS

- A. Materials shall be compatible with insulation materials, jackets, and substrates; comply with MIL-PRF-19565C, Type II.
1. For indoor applications, use mastics that have a VOC content of 50 g/L or less when calculated according to 40 CFR 59, Subpart D (EPA Method 24).
- B. Vapor-Barrier Mastic: Water based; suitable for indoor use on below-ambient services.
1. Products: Subject to compliance with requirements, provide one of the following:
    - a. Foster Brand, Specialty Construction Brands, Inc., a business of H. B. Fuller Company; 30-80/30-90.
    - b. Vimasco Corporation; 749.
  2. Water-Vapor Permeance: ASTM E 96/E 96M, Procedure B, 0.013 perm at 43-mil dry film thickness.
  3. Service Temperature Range: Minus 20 to plus 180 deg F.
  4. Solids Content: ASTM D 1644, 58 percent by volume and 70 percent by weight.
  5. Color: White.
- C. Vapor-Barrier Mastic: Solvent based; suitable for outdoor use on below-ambient services.
1. Products: Subject to compliance with requirements, provide one of the following:

- a. Childers Brand, Specialty Construction Brands, Inc., a business of H. B. Fuller Company; Encacel.
  - b. Eagle Bridges - Marathon Industries; 570.
  - c. Foster Brand, Specialty Construction Brands, Inc., a business of H. B. Fuller Company; 60-95/60-96.
2. Water-Vapor Permeance: ASTM F 1249, 0.05 perm at 30-mil dry film thickness.
  3. Service Temperature Range: Minus 50 to plus 220 deg F.
  4. Solids Content: ASTM D 1644, 33 percent by volume and 46 percent by weight.
  5. Color: White.
- D. Breather Mastic: Water based; suitable for indoor and outdoor use on above-ambient services.
1. Products: Subject to compliance with requirements, provide one of the following:
    - a. Childers Brand, Specialty Construction Brands, Inc., a business of H. B. Fuller Company; CP-10.
    - b. Eagle Bridges - Marathon Industries; 550.
    - c. Foster Brand, Specialty Construction Brands, Inc., a business of H. B. Fuller Company; 46-50.
    - d. Mon-Eco Industries, Inc.; 55-50.
    - e. Vimasco Corporation; WC-1/WC-5.
  2. Water-Vapor Permeance: ASTM F 1249, 1.8 perms at 0.0625-inch dry film thickness.
  3. Service Temperature Range: Minus 20 to plus 180 deg F.
  4. Solids Content: 60 percent by volume and 66 percent by weight.
  5. Color: White.

## 2.5 SEALANTS

- A. ASJ Flashing Sealants and PVC Jacket Flashing Sealants:
1. Products: Subject to compliance with requirements, provide the following:
    - a. Childers Brand, Specialty Construction Brands, Inc., a business of H. B. Fuller Company; CP-76.
  2. Materials shall be compatible with insulation materials, jackets, and substrates.
  3. Fire- and water-resistant, flexible, elastomeric sealant.
  4. Service Temperature Range: Minus 40 to plus 250 deg F.
  5. Color: White.
  6. For indoor applications, sealants shall have a VOC content of 420 g/L or less when calculated according to 40 CFR 59, Subpart D (EPA Method 24).

## 2.6 FACTORY-APPLIED JACKETS

- A. Insulation system schedules indicate factory-applied jackets on various applications. When factory-applied jackets are indicated, comply with the following:

1. ASJ-SSL: ASJ with self-sealing, pressure-sensitive, acrylic-based adhesive covered by a removable protective strip; complying with ASTM C 1136, Type I.

## 2.7 FIELD-APPLIED JACKETS

- A. Field-applied jackets shall comply with ASTM C 921, Type I, unless otherwise indicated.
- B. PVC Jacket: High-impact-resistant, UV-resistant PVC complying with ASTM D 1784, Class 16354-C; thickness as scheduled; roll stock ready for shop or field cutting and forming. Thickness is indicated in field-applied jacket schedules.
  1. Products: Subject to compliance with requirements, provide one of the following:
    - a. Johns Manville; Zeston.
    - b. P.I.C. Plastics, Inc.; FG Series.
    - c. Proto Corporation; LoSmoke.
    - d. Speedline Corporation; SmokeSafe.
  2. Adhesive: As recommended by jacket material manufacturer.
  3. Color: Color-code jackets based on system:
    - a. White
  4. Factory-fabricated fitting covers to match jacket if available; otherwise, field fabricate.
    - a. Shapes: 45- and 90-degree, short- and long-radius elbows, tees, valves, flanges, unions, reducers, end caps, soil-pipe hubs, traps, mechanical joints, and P-trap and supply covers for lavatories.
- C. Metal Jacket:
  1. Products: Subject to compliance with requirements, provide one of the following:
    - a. Childers Brand, Specialty Construction Brands, Inc., a business of H. B. Fuller Company; Metal Jacketing Systems.
    - b. ITW Insulation Systems; Aluminum and Stainless Steel Jacketing.
    - c. RPR Products, Inc.; Insul-Mate.
  2. Aluminum Jacket: Comply with ASTM B 209, Alloy 3003, 3005, 3105, or 5005, Temper H-14.
    - a. Sheet and roll stock ready for shop or field sizing or factory cut and rolled to size.
    - b. Finish and thickness are indicated in field-applied jacket schedules.
    - c. Moisture Barrier for Indoor Applications:
      - 1) 1-mil- thick, heat-bonded polyethylene and kraft paper.
    - d. Moisture Barrier for Outdoor Applications:
      - 1) 3-mil- thick, heat-bonded polyethylene and kraft paper.
    - e. Factory-Fabricated Fitting Covers:
      - 1) Same material, finish, and thickness as jacket.
      - 2) Preformed 2-piece or gore, 45- and 90-degree, short- and long-radius elbows.

- 3) Tee covers.
- 4) Flange and union covers.
- 5) End caps.
- 6) Beveled collars.
- 7) Valve covers.
- 8) Field fabricate fitting covers only if factory-fabricated fitting covers are not available.

## 2.8 TAPES

- A. ASJ Tape: White vapor-retarder tape matching factory-applied jacket with acrylic adhesive, complying with ASTM C 1136.
1. Products: Subject to compliance with requirements, provide one of the following:
    - a. ABI, Ideal Tape Division; 428 AWF ASJ.
    - b. Avery Dennison Corporation, Specialty Tapes Division; Fasson 0836.
    - c. Compac Corporation; 104 and 105.
    - d. Venture Tape; 1540 CW Plus, 1542 CW Plus, and 1542 CW Plus/SQ.
  2. Width: 3 inches.
  3. Thickness: 11.5 mils.
  4. Adhesion: 90 ounces force/inch in width.
  5. Elongation: 2 percent.
  6. Tensile Strength: 40 lbf/inch in width.
  7. ASJ Tape Disks and Squares: Precut disks or squares of ASJ tape.
- B. PVC Tape: White vapor-retarder tape matching field-applied PVC jacket with acrylic adhesive; suitable for indoor and outdoor applications.
1. Products: Subject to compliance with requirements, provide one of the following:
    - a. ABI, Ideal Tape Division; 370 White PVC tape.
    - b. Compac Corporation; 130.
    - c. Venture Tape; 1506 CW NS.
  2. Width: 2 inches.
  3. Thickness: 6 mils.
  4. Adhesion: 64 ounces force/inch in width.
  5. Elongation: 500 percent.
  6. Tensile Strength: 18 lbf/inch in width.
- C. Aluminum-Foil Tape: Vapor-retarder tape with acrylic adhesive.
1. Products: Subject to compliance with requirements, provide one of the following:
    - a. ABI, Ideal Tape Division; 488 AWF.
    - b. Avery Dennison Corporation, Specialty Tapes Division; Fasson 0800.
    - c. Compac Corporation; 120.
    - d. Venture Tape; 3520 CW.
  2. Width: 2 inches.

3. Thickness: 3.7 mils.
4. Adhesion: 100 ounces force/inch in width.
5. Elongation: 5 percent.
6. Tensile Strength: 34 lbf/inch in width.

## 2.9 SECUREMENTS

- A. Staples: Outward-clinching insulation staples, nominal 3/4-inch- wide, stainless steel or Monel.

## PART 3 - EXECUTION

### 3.1 EXAMINATION

- A. Examine substrates and conditions for compliance with requirements for installation tolerances and other conditions affecting performance of insulation application.
  1. Verify that systems to be insulated have been tested and are free of defects.
  2. Verify that surfaces to be insulated are clean and dry.
  3. Proceed with installation only after unsatisfactory conditions have been corrected.

### 3.2 PREPARATION

- A. Surface Preparation: Clean and dry surfaces to receive insulation. Remove materials that will adversely affect insulation application.
- B. Mix insulating cements with clean potable water; if insulating cements are to be in contact with stainless-steel surfaces, use demineralized water.

### 3.3 GENERAL INSTALLATION REQUIREMENTS

- A. Install insulation materials, accessories, and finishes with smooth, straight, and even surfaces; free of voids throughout the length of piping including fittings, valves, and specialties.
- B. Install insulation materials, forms, vapor barriers or retarders, jackets, and thicknesses required for each item of pipe system as specified in insulation system schedules.
- C. Install accessories compatible with insulation materials and suitable for the service. Install accessories that do not corrode, soften, or otherwise attack insulation or jacket in either wet or dry state.
- D. Install insulation with longitudinal seams at top and bottom of horizontal runs.
- E. Install multiple layers of insulation with longitudinal and end seams staggered.



- F. Do not weld brackets, clips, or other attachment devices to piping, fittings, and specialties.
- G. Keep insulation materials dry during application and finishing.
- H. Install insulation with tight longitudinal seams and end joints. Bond seams and joints with adhesive recommended by insulation material manufacturer.
- I. Install insulation with least number of joints practical.
- J. Where vapor barrier is indicated, seal joints, seams, and penetrations in insulation at hangers, supports, anchors, and other projections with vapor-barrier mastic.
  - 1. Install insulation continuously through hangers and around anchor attachments.
  - 2. For insulation application where vapor barriers are indicated, extend insulation on anchor legs from point of attachment to supported item to point of attachment to structure. Taper and seal ends at attachment to structure with vapor-barrier mastic.
  - 3. Install insert materials and install insulation to tightly join the insert. Seal insulation to insulation inserts with adhesive or sealing compound recommended by insulation material manufacturer.
  - 4. Cover inserts with jacket material matching adjacent pipe insulation. Install shields over jacket, arranged to protect jacket from tear or puncture by hanger, support, and shield.
- K. Apply adhesives, mastics, and sealants at manufacturer's recommended coverage rate and wet and dry film thicknesses.
- L. Install insulation with factory-applied jackets as follows:
  - 1. Draw jacket tight and smooth.
  - 2. Cover circumferential joints with 3-inch- wide strips, of same material as insulation jacket. Secure strips with adhesive and outward clinching staples along both edges of strip, spaced 4 inches o.c.
  - 3. Overlap jacket longitudinal seams at least 1-1/2 inches. Install insulation with longitudinal seams at bottom of pipe. Clean and dry surface to receive self-sealing lap. Staple laps with outward clinching staples along edge at
    - a. 2 inches o.c.
    - b. For below-ambient services, apply vapor-barrier mastic over staples.
  - 4. Cover joints and seams with tape, according to insulation material manufacturer's written instructions, to maintain vapor seal.
  - 5. Where vapor barriers are indicated, apply vapor-barrier mastic on seams and joints and at ends adjacent to pipe flanges and fittings.
- M. Cut insulation in a manner to avoid compressing insulation more than 75 percent of its nominal thickness.
- N. Finish installation with systems at operating conditions. Repair joint separations and cracking due to thermal movement.

- O. Repair damaged insulation facings by applying same facing material over damaged areas. Extend patches at least 4 inches beyond damaged areas. Adhere, staple, and seal patches similar to butt joints.
- P. For above-ambient services, do not install insulation to the following:
  - 1. Vibration-control devices.
  - 2. Testing agency labels and stamps.
  - 3. Nameplates and data plates.
  - 4. Manholes.
  - 5. Handholes.
  - 6. Cleanouts.

### 3.4 PENETRATIONS

- A. Insulation Installation at Roof Penetrations: Install insulation continuously through roof penetrations.
  - 1. Seal penetrations with flashing sealant.
  - 2. For applications requiring only indoor insulation, terminate insulation above roof surface and seal with joint sealant. For applications requiring indoor and outdoor insulation, install insulation for outdoor applications tightly joined to indoor insulation ends. Seal joint with joint sealant.
  - 3. Extend jacket of outdoor insulation outside roof flashing at least 2 inches below top of roof flashing.
  - 4. Seal jacket to roof flashing with flashing sealant.
- B. Insulation Installation at Underground Exterior Wall Penetrations: Terminate insulation flush with sleeve seal. Seal terminations with flashing sealant.
- C. Insulation Installation at Aboveground Exterior Wall Penetrations: Install insulation continuously through wall penetrations.
  - 1. Seal penetrations with flashing sealant.
  - 2. For applications requiring only indoor insulation, terminate insulation inside wall surface and seal with joint sealant. For applications requiring indoor and outdoor insulation, install insulation for outdoor applications tightly joined to indoor insulation ends. Seal joint with joint sealant.
  - 3. Extend jacket of outdoor insulation outside wall flashing and overlap wall flashing at least 2 inches.
  - 4. Seal jacket to wall flashing with flashing sealant.
- D. Insulation Installation at Interior Wall and Partition Penetrations (That Are Not Fire Rated): Install insulation continuously through walls and partitions.
- E. Insulation Installation at Fire-Rated Wall and Partition Penetrations: Install insulation continuously through penetrations of fire-rated walls and partitions.
  - 1. Comply with requirements in Section 078413 "Penetration Firestopping" for firestopping and fire-resistive joint sealers.
- F. Insulation Installation at Floor Penetrations:

1. Pipe: Install insulation continuously through floor penetrations.
2. Seal penetrations through fire-rated assemblies. Comply with requirements in Section 078413 "Penetration Firestopping."

### 3.5 GENERAL PIPE INSULATION INSTALLATION

- A. Requirements in this article generally apply to all insulation materials except where more specific requirements are specified in various pipe insulation material installation articles.
- B. Insulation Installation on Fittings, Valves, Strainers, Flanges, and Unions:
  1. Install insulation over fittings, valves, strainers, flanges, unions, and other specialties with continuous thermal and vapor-retarder integrity unless otherwise indicated.
  2. Insulate pipe elbows using preformed fitting insulation or mitered fittings made from same material and density as adjacent pipe insulation. Each piece shall be butted tightly against adjoining piece and bonded with adhesive. Fill joints, seams, voids, and irregular surfaces with insulating cement finished to a smooth, hard, and uniform contour that is uniform with adjoining pipe insulation.
  3. Insulate tee fittings with preformed fitting insulation or sectional pipe insulation of same material and thickness as used for adjacent pipe. Cut sectional pipe insulation to fit. Butt each section closely to the next and hold in place with tie wire. Bond pieces with adhesive.
  4. Insulate valves using preformed fitting insulation or sectional pipe insulation of same material, density, and thickness as used for adjacent pipe. Overlap adjoining pipe insulation by not less than two times the thickness of pipe insulation, or one pipe diameter, whichever is thicker. For valves, insulate up to and including the bonnets, valve stuffing-box studs, bolts, and nuts. Fill joints, seams, and irregular surfaces with insulating cement.
  5. Insulate strainers using preformed fitting insulation or sectional pipe insulation of same material, density, and thickness as used for adjacent pipe. Overlap adjoining pipe insulation by not less than two times the thickness of pipe insulation, or one pipe diameter, whichever is thicker. Fill joints, seams, and irregular surfaces with insulating cement. Insulate strainers so strainer basket flange or plug can be easily removed and replaced without damaging the insulation and jacket. Provide a removable reusable insulation cover. For below-ambient services, provide a design that maintains vapor barrier.
  6. Insulate flanges and unions using a section of oversized preformed pipe insulation. Overlap adjoining pipe insulation by not less than two times the thickness of pipe insulation, or one pipe diameter, whichever is thicker.
  7. Cover segmented insulated surfaces with a layer of finishing cement and coat with a mastic. Install vapor-barrier mastic for below-ambient services and a breather mastic for above-ambient services. Reinforce the mastic with fabric-reinforcing mesh. Trowel the mastic to a smooth and well-shaped contour.
  8. For services not specified to receive a field-applied jacket except for flexible elastomeric install fitted PVC cover over elbows, tees, strainers, valves, flanges, and unions. Terminate ends with PVC end caps. Tape PVC covers to adjoining insulation facing using PVC tape.
  9. Stencil or label the outside insulation jacket of each union with the word "union." Match size and color of pipe labels.

- C. Insulate instrument connections for thermometers, pressure gages, pressure temperature taps, test connections, flow meters, sensors, switches, and transmitters on insulated pipes. Shape insulation at these connections by tapering it to and around the connection with insulating cement and finish with finishing cement, mastic, and flashing sealant.
- D. Install removable insulation covers at locations indicated. Installation shall conform to the following:
  - 1. Make removable flange and union insulation from sectional pipe insulation of same thickness as that on adjoining pipe. Install same insulation jacket as adjoining pipe insulation.
  - 2. When flange and union covers are made from sectional pipe insulation, extend insulation from flanges or union long at least two times the insulation thickness over adjacent pipe insulation on each side of flange or union. Secure flange cover in place with stainless-steel or aluminum bands. Select band material compatible with insulation and jacket.
  - 3. Construct removable valve insulation covers in same manner as for flanges, except divide the two-part section on the vertical center line of valve body.
  - 4. When covers are made from block insulation, make two halves, each consisting of mitered blocks wired to stainless-steel fabric. Secure this wire frame, with its attached insulation, to flanges with tie wire. Extend insulation at least 2 inches over adjacent pipe insulation on each side of valve. Fill space between flange or union cover and pipe insulation with insulating cement. Finish cover assembly with insulating cement applied in two coats. After first coat is dry, apply and trowel second coat to a smooth finish.
  - 5. Unless a PVC jacket is indicated in field-applied jacket schedules, finish exposed surfaces with a metal jacket.

### 3.6 INSTALLATION OF CALCIUM SILICATE INSULATION

- A. Insulation Installation on Straight Pipes and Tubes:
  - 1. Secure single-layer insulation with stainless-steel bands at 12-inch intervals and tighten bands without deforming insulation materials.
  - 2. Install two-layer insulation with joints tightly butted and staggered at least 3 inches. Secure inner layer with wire spaced at 12-inch intervals. Secure outer layer with stainless-steel bands at 12-inch intervals.
  - 3. Apply a skim coat of mineral-fiber, hydraulic-setting cement to insulation surface. When cement is dry, apply flood coat of lagging adhesive and press on one layer of glass cloth or tape. Overlap edges at least 1 inch. Apply finish coat of lagging adhesive over glass cloth or tape. Thin finish coat to achieve smooth, uniform finish.
- B. Insulation Installation on Pipe Flanges:
  - 1. Install preformed pipe insulation to outer diameter of pipe flange.
  - 2. Make width of insulation section same as overall width of flange and bolts, plus twice the thickness of pipe insulation.
  - 3. Fill voids between inner circumference of flange insulation and outer circumference of adjacent straight pipe segments with cut sections of block insulation of same material and thickness as pipe insulation.

4. Finish flange insulation same as pipe insulation.

C. Insulation Installation on Pipe Fittings and Elbows:

1. Install preformed sections of same material as straight segments of pipe insulation when available. Secure according to manufacturer's written instructions.
2. When preformed insulation sections of insulation are not available, install mitered sections of calcium silicate insulation. Secure insulation materials with wire or bands.
3. Finish fittings insulation same as pipe insulation.

D. Insulation Installation on Valves and Pipe Specialties:

1. Install mitered segments of calcium silicate insulation to valve body. Arrange insulation to permit access to packing and to allow valve operation without disturbing insulation.
2. Install insulation to flanges as specified for flange insulation application.
3. Finish valve and specialty insulation same as pipe insulation.

### 3.7 INSTALLATION OF FLEXIBLE ELASTOMERIC INSULATION

- A. Seal longitudinal seams and end joints with manufacturer's recommended adhesive to eliminate openings in insulation that allow passage of air to surface being insulated.

B. Insulation Installation on Pipe Flanges:

1. Install pipe insulation to outer diameter of pipe flange.
2. Make width of insulation section same as overall width of flange and bolts, plus twice the thickness of pipe insulation.
3. Fill voids between inner circumference of flange insulation and outer circumference of adjacent straight pipe segments with cut sections of sheet insulation of same thickness as pipe insulation.
4. Secure insulation to flanges and seal seams with manufacturer's recommended adhesive to eliminate openings in insulation that allow passage of air to surface being insulated.

C. Insulation Installation on Pipe Fittings and Elbows:

1. Install mitered sections of pipe insulation.
2. Secure insulation materials and seal seams with manufacturer's recommended adhesive to eliminate openings in insulation that allow passage of air to surface being insulated.

D. Insulation Installation on Valves and Pipe Specialties:

1. Install preformed valve covers manufactured of same material as pipe insulation when available.
2. When preformed valve covers are not available, install cut sections of pipe and sheet insulation to valve body. Arrange insulation to permit access to packing and to allow valve operation without disturbing insulation.
3. Install insulation to flanges as specified for flange insulation application.

4. Secure insulation to valves and specialties and seal seams with manufacturer's recommended adhesive to eliminate openings in insulation that allow passage of air to surface being insulated.

### 3.8 INSTALLATION OF MINERAL-FIBER INSULATION

#### A. Insulation Installation on Straight Pipes and Tubes:

1. Secure each layer of preformed pipe insulation to pipe with wire or bands and tighten bands without deforming insulation materials.
2. Where vapor barriers are indicated, seal longitudinal seams, end joints, and protrusions with vapor-barrier mastic and joint sealant.
3. For insulation with factory-applied jackets on above-ambient surfaces, secure laps with outward-clinched staples at 6 inches o.c.
4. For insulation with factory-applied jackets on below-ambient surfaces, do not staple longitudinal tabs. Instead, secure tabs with additional adhesive as recommended by insulation material manufacturer and seal with vapor-barrier mastic and flashing sealant.

#### B. Insulation Installation on Pipe Flanges:

1. Install preformed pipe insulation to outer diameter of pipe flange.
2. Make width of insulation section same as overall width of flange and bolts, plus twice the thickness of pipe insulation.
3. Fill voids between inner circumference of flange insulation and outer circumference of adjacent straight pipe segments with mineral-fiber blanket insulation.
4. Install jacket material with manufacturer's recommended adhesive, overlap seams at least 1 inch, and seal joints with flashing sealant.

#### C. Insulation Installation on Pipe Fittings and Elbows:

1. Install preformed sections of same material as straight segments of pipe insulation when available.
2. When preformed insulation elbows and fittings are not available, install mitered sections of pipe insulation, to a thickness equal to adjoining pipe insulation. Secure insulation materials with wire or bands.

#### D. Insulation Installation on Valves and Pipe Specialties:

1. Install preformed sections of same material as straight segments of pipe insulation when available.
2. When preformed sections are not available, install mitered sections of pipe insulation to valve body.
3. Arrange insulation to permit access to packing and to allow valve operation without disturbing insulation.
4. Install insulation to flanges as specified for flange insulation application.

### 3.9 FIELD-APPLIED JACKET INSTALLATION

- A. Where PVC jackets are indicated, install with 1-inch overlap at longitudinal seams and end joints; for horizontal applications. Seal with manufacturer's recommended adhesive.
  - 1. Apply two continuous beads of adhesive to seams and joints, one bead under lap and the finish bead along seam and joint edge.
- B. Where metal jackets are indicated, install with 2-inch overlap at longitudinal seams and end joints. Overlap longitudinal seams arranged to shed water. Seal end joints with weatherproof sealant recommended by insulation manufacturer. Secure jacket with stainless-steel bands 12 inches o.c. and at end joints.

### 3.10 FINISHES

- A. Pipe Insulation with ASJ, Glass-Cloth, or Other Paintable Jacket Material: Paint jacket with paint system identified below and as specified in Section 09 9113 "Exterior Painting" and Section 09 9123 "Interior Painting."
  - 1. Flat Acrylic Finish: Two finish coats over a primer that is compatible with jacket material and finish coat paint. Add fungicidal agent to render fabric mildew proof.
    - a. Finish Coat Material: Interior, flat, latex-emulsion size.
- B. Flexible Elastomeric Thermal Insulation: After adhesive has fully cured, apply two coats of insulation manufacturer's recommended protective coating.
- C. Color: Final color as selected by Architect. Vary first and second coats to allow visual inspection of the completed Work.
- D. Do not field paint aluminum or stainless-steel jackets.

### 3.11 PIPING INSULATION SCHEDULE, GENERAL

- A. Acceptable preformed pipe and tubular insulation materials and thicknesses are identified for each piping system and pipe size range. If more than one material is listed for a piping system, selection from materials listed is Contractor's option.
- B. Items Not Insulated: Unless otherwise indicated, do not install insulation on the following:
  - 1. Drainage piping located in crawl spaces.
  - 2. Underground piping.
  - 3. Chrome-plated pipes and fittings unless there is a potential for personnel injury.

3.12 Insulation shall have a k value that meets the minimum requirements of the latest International Energy Conservation Code (IECC).

3.13 INDOOR PIPING INSULATION SCHEDULE

A. Condensate and Equipment Drain Water below 60 Deg F:

1. All Pipe Sizes: Insulation shall be one of the following:
  - a. Flexible Elastomeric:
    - 1) 1/2 inch thick
  - b. Mineral-Fiber, Preformed Pipe Insulation, Type I:
    - 1) 1/2 inch thick

B. Chilled Water, 40 Deg F and below:

1. NPS 1-1/2 inch and Smaller: Insulation shall be the following:
  - a. Flexible Elastomeric:
    - 1) 1-1/2 inch thick.
2. NPS 2 inch and Larger: Insulation shall be the following:
  - a. Flexible Elastomeric:
    - 1) 1-1/2 inch thick.
3. Insulation for runouts not exceeding 48 inches in length for connection to equipment shall be the following:
  - a. Flexible Elastomeric: 1 inch thick.

C. Chilled Water, above 40 Deg F:

1. NPS 1-1/2 inch and Smaller: Insulation shall be one of the following:
  - a. Flexible Elastomeric:
    - 1) 1-1/2 inch thick.
  - b. Mineral-Fiber, Preformed Pipe, Type I:
    - 1) 1-1/2 inches thick.
2. NPS 2 inch and Larger: Insulation shall be one of the following:
  - a. Flexible Elastomeric:
    - 1) 1-1/2 inch thick.
  - b. Mineral-Fiber, Preformed Pipe, Type I:
    - 1) 1-1/2 inches thick.
3. Insulation runouts not exceeding 48 inches in length for connection to equipment shall be one of the following:
  - a. Flexible Elastomeric: 1 inch thick.
  - b. Mineral-Fiber, Preformed Pipe, Type I: 1 inch thick
4. Condenser-water supply and return piping located indoors and operating in range of 55 to 105 deg F (13 to 41 deg C) is not always insulated. If condenser-water system operates as part of a water-side economizer cycle or if Project requires condensation control, piping should be insulated.



- D. Heating-Hot-Water Supply and Return, 200 Deg F and Below:
1. NPS 1 1/2 and Smaller: Insulation shall be the following:
    - a. Mineral-Fiber, Preformed Pipe, Type I:
      - 1) 1-1/2 inch thick
  2. Greater than NPS 1-1/2 inch : Insulation shall be the following:
    - a. Mineral-Fiber, Preformed Pipe, Type I or Pipe and Tank Insulation:
      - 1) 2 inches thick
  3. Insulation for runouts not exceeding 48 inches in length for connection to equipment shall be the following:
    - a. Mineral-Fiber, Preformed Pipe, Type I: 1 inch thick.
- E. Heating-Hot-Water Supply and Return, above 200 Deg F:
1. NPS 1 and Smaller: Insulation shall be one of the following:
    - a. Calcium Silicate:
      - 1) 2 inches thick
    - b. Mineral-Fiber, Preformed Pipe, Type I or II:
      - 1) 1-1/2 inches thick
  2. NPS 1-1/4 and Larger: Insulation shall be one of the following:
    - a. Calcium Silicate:
      - 1) 3 inches thick
    - b. Mineral-Fiber, Preformed Pipe, Type I or II:
      - 1) 2 inches thick
  3. Insulation runouts not exceeding 48 inches in length for connection to equipment shall be the following:
    - a. Mineral-Fiber, Preformed Pipe, Type I: 1-1/2 inch thick.
- F. Refrigerant Suction and Hot-Gas Piping:
1. All Pipe Sizes: Insulation shall be the following:
    - a. Flexible Elastomeric: 1 inch thick.
- G. Refrigerant Suction and Hot-Gas Flexible Tubing:
1. All Pipe Sizes: Insulation shall be the following:
    - a. Flexible Elastomeric: 1 inch thick.
- 3.14 INDOOR, FIELD-APPLIED JACKET SCHEDULE
- A. Install jacket over insulation material. For insulation with factory-applied jacket, install the field-applied jacket over the factory-applied jacket.

- B. If more than one material is listed, selection from materials listed is Contractor's option.
- C. Piping, Concealed:
  - 1. None.
- D. Piping, Exposed:
  - 1. PVC:
    - a. White: 30 mils thick.

END OF SECTION

**SECTION 23 09 00 - INSTRUMENTATION AND CONTROL FOR HVAC**

## PART 1 - GENERAL

## 1.1 SUMMARY

- A. This Section includes control equipment and installation for HVAC systems and components, including control components for terminal heating and cooling units not supplied with factory-furnished controls.
- B. See "Sequences of Operation" for requirements that relate to this Section.
- C. The BAS control system shall be extension of the existing Siemens Apogee BAS and all controllers and software shall match existing or be latest version of existing.

## 1.2 SYSTEM DESCRIPTION

- A. The Building Automation System (BAS) contractor shall furnish and install a networked system of HVAC controls. The contractor shall incorporate direct digital control (DDC) for central plant equipment, building ventilation equipment, supplemental heating and cooling equipment, and terminal units.
- B. Provide networking to new DDC equipment using communication standards. The system shall not be limited to only standard protocols, but shall also be able to integrate to a wide variety of third-party devices and applications via drivers and gateways.
- C. Provide standalone controls where called for on the drawings or sequences.

## 1.3 WORK INCLUDED

- A. The installation of the control system shall be performed under the direct supervision of the controls manufacturer with the shop drawings, flow diagrams, bill of materials, component designation, or identification number and sequence of operation all bearing the name of the manufacturer.
- B. Furnish a complete distributed direct digital control system in accordance with this specification section. This includes all system controllers, logic controllers, and all input/output devices. Items of work included are as follows:
  - 1. Provide a submittal that meets the requirements below for approval.
  - 2. Coordinate installation schedule with the mechanical contractor and general contractor.
  - 3. Provide installation of all panels and devices unless otherwise stated.
  - 4. Provide power for panels and control devices.
  - 5. Provide all low voltage control wiring for the DDC system.
  - 6. Provide miscellaneous control wiring for HVAC and related systems regardless of voltage.
  - 7. Provide engineering and technician labor to program and commission software for each system and operator interface. Submit commissioning reports for approval.

8. Participate in commissioning for all equipment that is integrated into the BAS (Refer to Commissioning sections of the equipment or systems in other parts of this specification.)
9. Provide testing, demonstration and training as specified below.

#### 1.4 SYSTEM PERFORMANCE

- A. Comply with the following performance requirements:
  1. Reporting Accuracy and Stability of Control: Report values and maintain measured variables within tolerances as follows:
    - a. Water Temperature: Plus or minus 1 deg F.
    - b. Water Flow: Plus or minus 5 percent of full scale.
    - c. Water Pressure: Plus or minus 2 percent of full scale.
    - d. Space Temperature: Plus or minus 1 deg F.
    - e. Ducted Air Temperature: Plus or minus 1 deg F.
    - f. Outside Air Temperature: Plus or minus 2 deg F.
    - g. Dew Point Temperature: Plus or minus 3 deg F.
    - h. Temperature Differential: Plus or minus 0.25 deg F.
    - i. Relative Humidity: Plus or minus 2 percent.
    - j. Airflow (Pressurized Spaces): Plus or minus 3 percent of full scale.
    - k. Airflow (Measuring Stations): Plus or minus 5 percent of full scale.
    - l. Airflow (Terminal): Plus or minus 10 percent of full scale.
    - m. Air Pressure (Space): Plus or minus 0.01-inch wg.
    - n. Air Pressure (Ducts): Plus or minus 0.1-inch wg.
    - o. Carbon Monoxide: Plus or minus 5 percent of reading.
    - p. Carbon Dioxide: Plus or minus 50 ppm.
    - q. Electrical: Plus or minus 5 percent of reading.

#### 1.5 SUBMITTALS

- A. Provide submittals for fast track items that need to be approved and released to meet the schedule of the project. Provide submissions for the following items separately:
  1. Valve schedule and cut sheets
  2. Factory mounting and wiring diagrams and cut sheets
  3. Thermostat locations
- B. Provide a complete submittal with all controls system information for approval before construction starts. Include the following:
  1. Wiring Diagrams: Power, signal, and control wiring.
  2. Schedule of valves including leakage and flow characteristics.
  3. Written description of the Sequence of Operations.
  4. Network riser diagram showing wiring types, network protocols, locations of floor penetrations and number of control panels. Label control panels with network addresses. Show all routers, switches, hubs and repeaters.
  5. Point list for each system controller including both inputs and outputs (I/O), point numbers, controlled device associated with each I/O point, and location of I/O device.
  6. Starter and variable frequency drive wiring details of all automatically controlled motors.
- C. Product Data: Include manufacturer's technical literature for each control device indicated, labeled with setting or adjustable range of control. Indicate dimensions,

capacities, performance characteristics, electrical characteristics, finishes for materials, and installation and startup instructions for each type of product indicated. Submit a write-up of the application software that will be used on the operator workstation including revision level, functionality and software applications required to meet the specifications.

- D. Wiring Diagrams: Detail the wiring of the control devices and the panels. Show point-to-point wiring from field devices to the control panel. Show point-to-point wiring of hardwired interlocks. Show a ladder diagram or schematic of wiring internal to the panels, including numbered terminals. Clearly designate wiring that is done at a factory, at a panel shop or in the field.
- E. Variance letter: Submit a letter detailing each item in the submission that varies from the contract specification or sequence of operation in any way.

#### 1.6 COORDINATION

- A. Coordinate location of thermostats, humidistats, panels, and other exposed control components with plans and room details before installation.
- B. Coordinate power for control units and operator workstation with electrical contractor.
- C. Coordinate equipment with provider of starters and drives to achieve compatibility with motor starter control coils and VFD control wiring.
- D. Coordinate scheduling with the mechanical contractor and general contractor. Submit a schedule for approval based upon the installation schedule of the mechanical equipment.
- E. Products Furnished but Not Installed Under This Section
  - 1. Hydronic Piping:
    - a. Control Valves
    - b. Temperature Sensor Wells and Sockets
    - c. Flow Switches
    - d. Flow Meters
  - 2. Sheetmetal accessories
    - a. Dampers
    - b. Airflow Stations
    - c. Terminal Unit Controls
- F. Integrate to equipment as called for in the sequence of operations

#### 1.7 WARRANTY

- A. Warranty shall cover all costs for parts, labor, associated travel, and expenses for a period of one year from completion of system demonstration.
- B. This warranty shall apply equally to both hardware and software.

#### PART 2 - PRODUCTS

## 2.1 ACCEPTABLE SYSTEMS

- A. Provide an extension to an existing Siemens APOGEE System as installed by the Siemens Industry branch office.
- B. The vendors and products listed shall comply with these specifications. It shall not be assumed that standard products and methods will be acceptable without prior approval. Exceptions shall be noted during the bid process and documented in the submittal process.

## 2.2 ELECTRONIC DOCUMENTATION

- A. Provide all controls cut sheets in PDF format. Make them available to any user accessing the system over the Internet.
- B. Provide a text version of the sequence of operation. Make the written sequence available from the graphic that represents each system.

## 2.3 CONTROLLER SOFTWARE (i.e. Building Controller software, DDC software, Field Panel software)

- A. Reuse existing software. If new controllers need updated versions of the controller software, then provide updated versions, such that at the completion of this project, the Owner has controller software licenses for all of the existing and new generations of controllers.

## 2.4 GENERAL SPECIFICATIONS FOR DEVICES

- A. Provide mounting hardware for all devices, including actuator linkages, wells, installation kits for insertion devices, wall boxes and fudge plates, brackets, etc.
- B. If a special tool is required to mount a device, provide that tool.

## 2.5 SENSORS

- A. Terminal Unit Space Thermostats
  - 1. Each controller performing space temperature control shall be provided with a matching room temperature sensor.
    - a. Plain Space Temperature Sensors – Wired: Where called for in the sequences or on the drawings, provide sensors with plain covers.
    - b. The sensing element for the space temperature sensor shall be thermistor type providing the following.
      - 1) Element Accuracy: + /- 1.0°F
      - 2) Operating Range: 55 to 95°F
      - 3) Set Point Adjustment Range: 55 to 95°F
      - 4) Calibration Adjustments: None required
      - 5) Installation: Up to 100 ft. from controller
      - 6) Auxiliary Communications Port: as required
      - 7) Local LCD Temperature Display: as required
      - 8) Setpoint Adjustment Dial as required

## 9) Occupancy Override Switch as required

2. Provide the following options as they are called for in the sequences or on the drawings:
    - a. Setpoint Adjustment. The setpoint adjustment function shall allow for modification of the temperature by the building operators. Setpoint adjustment may be locked out, overridden, or limited as to time or temperature through software by an authorized operator at any central workstation, Building Controller, room sensor two-line display, or via the portable operator's terminal.
    - b. Override Switch. An override button shall initiate override of the night setback mode to normal (day) operation when activated by the occupant and enabled by building operators. The override shall be limited to two (2) hours (adjustable.) The override function may be locked out, overridden, or limited through software by an authorized operator at the operator interface, Building Controller, room sensor two-line display or via the portable operator's terminal.
    - c. Space Combination Temperature and Humidity Sensors. Each controller performing space temperature control shall be provided with a matching room temperature sensor, which also includes the ability to measure humidity for either monitoring or control purposes. The combination temperature and humidity sensors shall have the same appearance as the space temperature sensors. Humidity elements shall measure relative humidity with a +/- 2% accuracy over the range of 10 to 90% relative humidity. Humidity element shall be an IC (integrated circuit) sensing element. Humidity sensing elements shall be removable and field replaceable if needed.
- B. Temperature Sensors
1. All temperature sensors shall meet the following specifications:
    - a. Accuracy: Plus or minus 0.2 percent at calibration point.
    - b. Wire: Twisted, shielded-pair cable.
    - c. Vibration and corrosion resistant
  2. Space temperature sensors shall meet the following specifications:
    - a. 10k ohm type 2 thermisters
  3. Insertion Elements in Ducts shall meet the following specifications:
    - a. Single point 10k ohm thermister
    - b. Use where not affected by temperature stratification
    - c. The sensor shall reach more than 1/3 the distance from the duct wall
    - d. Junction box for wire splices
  4. Averaging Elements in Ducts shall meet the following specifications:
    - a. 72 inches (183 cm) long
    - b. Flexible
    - c. Use where prone to temperature stratification, in front of coils, or where ducts are larger than 9 sq. ft.
    - d. Junction box for wire splices
  5. Insertion Elements for Liquids shall meet the following specifications:
    - a. Platinum RTD with 4-20mA transmitter
    - b. Threaded mounting with matching well
    - c. Brass well with minimum insertion length of 2-1/2 inches for pipes up to 4" diameter
    - d. Brass well with insertion length of 6 inches for pipes up to 10" diameter
    - e. Junction box for wire splices
- C. Humidity Sensors shall meet the following specifications:

1. Bulk polymer sensor element
  2. Accuracy: 2 percent full range with linear output
  3. Room Sensors: With locking cover matching room thermostats, span of 0 to 100 percent relative humidity
  4. Duct and Outside-Air Sensors: With element guard and mounting plate, range of 0 to 100 percent relative humidity
- D. Air Static Pressure Transmitter shall meet the following specifications:
1. Non-directional sensor with suitable range for expected input, and temperature compensated.
  2. Accuracy: 2 percent of full scale with repeatability of 0.5 percent.
  3. Output: 4 to 20 mA.
  4. Building Static-Pressure Range: 0 to 0.25 inches wg.
  5. Duct Static-Pressure Range: 0 to 5 inches wg.
- E. Pressure Transmitters: Direct acting for gas, liquid, or steam service; range suitable for system; proportional output 4 to 20 mA.
- F. Equipment operation sensors as follows:
1. Status Inputs for direct drive electric motors: Current-sensing relay with current transformers, adjustable and sized for 175 percent of rated motor current.
  2. Status inputs for belt drive electric motors: Current sensing transmitter with linear 4-20mA output
- G. Air Differential Pressure Switches: Diaphragm type air differential pressure switches with die cast aluminum housing, adjustable setpoint, minimum 5 amp switch rating at 120VAC, SPDT switches, and the switch pressure range shall be suited for the application. Provide Dwyer or equal. These switches shall be utilized for filter status.

## 2.6 AUTOMATIC CONTROL VALVES

- A. General:
1. All automatic control valves shall be fully proportioning, unless specified otherwise. The valves shall be quiet in operation and fail-safe in either normally open or normally closed position in the event of control air failure. All valves shall be capable of operating at varying rates of speed to correspond to the exact dictates of the controllers and variable load requirements. The valves shall be capable of operating in sequence with other valves and/or dampers when required by the sequence of operation. All control valves shall be sized by the control vendor and shall be guaranteed to accommodate the flow rates as scheduled. All control valves shall be suitable for the pressure conditions and shall close against the differential pressures involved. Body pressure rating and connection type construction shall conform to fitting and valve schedules. Control valve operators shall be sized to close against a differential pressure equal to the design pump heads plus 10 percent.
  2. Cold water, hot water and steam valves, throttling type, and bypass valves shall have equal percentage flow characteristics.
  3. Unless otherwise specified, control valves 2 inches and smaller shall have cast iron or bronze bodies with screwed NPT connections.
  4. Valves between 2-1/2 inch and 4 inch shall have cast iron bodies with flanged connections.
  5. All automatic control valves installed exposed to the elements shall be provided with electric actuators with operating characteristics and accessories as described



- in herein. Coordinate with electrical contractor for power availability and point of connection.
6. All automatic control valves controlled by the BAS shall be furnished by the controls contractor unless noted otherwise in these documents.
  7. All automatic control valves shall be installed by the mechanical trade.
  8. The controls contractor shall provide wiring as follows:
    - a. All line voltage power for electric valve actuators shall be wired by the controls contractor from the nearest available power panel. Coordinate with electrical trade.
    - b. All wiring between the central control system (ATC/BMS) and the valve actuator shall be wired by the controls contractor.
    - c. All wiring between the valve actuator and their associated thermostats, pressure switches, control devices, etc. shall be wired by the controls contractor.
    - d. All wiring shall comply with code requirements. Segregate high and low voltage wiring & circuits and segregate the FAS and controls (BMS) terminals.
- B. Hot Water / Condenser Water / Control Valves
1. Single-seated.
  2. Fully proportioning with modulating plug or V-port inner valves.
  3. Body pressure rating and connection type construction shall conform to fitting and valve schedules. The ANSI rating of the valve shall match the ANSI rating of the piping in which the valve is installed. Minimum ANSI rating shall be ANSI 125.
  4. Stainless steel stems and trim.
  5. Spring loaded Teflon packing
  6. Quiet in operation.
  7. Fail-safe in either normally open or normally closed position in the event of power failure.
  8. Capable of operating in sequence with other valves and/or dampers when required by the sequence of operation.
  9. Capable of operating at varying rates of speed to correspond to the exact dictates of the controller and variable load requirements.
- C. Differential Pressure Control Valves :
1. Provide for all water systems where modulating water flow conditions are required to prevent excessive pump pressure build-up. Provide a valve for each closed loop water system. Valve to be globe type. Provide valves 2" and smaller with screwed end bodies and provide valves 2-1/2" and larger with flanged ends.

## 2.7 ELECTRONIC ACTUATOR SPECIFICATION

### A. ELECTRONIC VALVE ACTUATORS

1. Actuator shall be fully modulating, floating (tri-state), two position, and/or spring return as indicated in the control sequences. Specified fail safe actuators shall require mechanical spring return.
2. Modulating valves shall be positive positioning, responding to a 2-10VDC or 4-20mA signal. There shall be a visual valve position indicator.

3. The actuator shall have the capability of adding auxiliary switches or feedback potentiometer if specified.
4. Actuator shall provide minimum torque required for proper valve close-off. The actuator shall be designed with a current limiting motor protection. A release button (clutch) or handle on the actuator shall be provided to allow for manual override (except when actuator is spring return type).
5. Actuators shall be UL listed.

#### B. ELECTRONIC DAMPER ACTUATORS

1. Actuator shall be direct coupled (over the shaft), enabling it to be mounted directly to the damper shaft without the need for connecting linkage. The actuator-to-shaft clamp shall use a "V" bolt and "V" shaped, toothed cradle to attach to the damper shaft for maximum holding strength. Single bolt or set screw type fasteners are not acceptable.
2. Actuator shall have electronic overload or digital rotation sensing circuitry to prevent damage to the actuator throughout the rotation of the actuator. End switches to deactivate the actuator at the end of rotation or magnetic clutch are not acceptable.
3. For power-failure/safety applications, a mechanical, spring return mechanism shall be used.
4. Actuators with spring return mechanisms shall be capable of either clockwise or counterclockwise spring return operation by simply changing the mounting orientation.
5. Proportional actuators shall accept a 2-10VDC, 4-20mA signal, or be of the 2 point floating type and provide a 2-10VDC actuator position feedback signal.
6. All actuators shall have an external manual gear release (clutch) or manual crank to aid in installation and for allowing manual positioning when the actuator is not powered.
7. All actuators shall have an external direction of rotation switch to aid in installation and to allow proper control response.
8. Actuators shall be provided with a factory-mounted 3-foot electrical cable and conduit fitting to provide easy hook-up to an electrical junction box.
9. Actuators shall be listed under Underwriters Laboratories Standard 873 and Canadian Standards Association. They must be manufactured under ISO 9001.

#### 2.8 EXECUTION

- A. The project plans shall be thoroughly examined for control device and equipment locations. Any discrepancies, conflicts, or omissions shall be reported to the architect/engineer for resolution before rough-in work is started.
- B. The contractor shall inspect the site to verify that equipment may be installed as shown. Any discrepancies, conflicts, or omissions shall be reported to the engineer for resolution before rough-in work is started.
- C. The contractor shall examine the drawings and specifications for other parts of the work. If head room or space conditions appear inadequate—or if any discrepancies occur between the plans and the contractor's work and the plans and the work of others—the contractor shall report these discrepancies to the engineer and shall obtain written instructions for any changes necessary to accommodate the contractor's work with the work of others.

## 2.8 INSTALLATION

- A. Provide all relays, switches, and all other auxiliaries, accessories and connections necessary to make a complete operable system in accordance with the sequences specified. All field wiring shall be by this contractor.
- B. Install controls so that adjustments and calibrations can be readily made. Controls are to be installed by the control equipment manufacturer.
- C. Mount surface-mounted control devices on brackets to clear the final finished surface on insulation.
- D. Install equipment level and plumb.
- E. Install control valves horizontally with the power unit up.
- F. Unless otherwise noted, install wall mounted thermostats and humidistat 60" above the floor measured to the center line of the instrument, or as otherwise directed by the Architect.
- G. Install averaging elements in ducts and plenums in horizontal crossing or zigzag pattern.
- H. Install damper motors on outside of duct in protected areas, not in locations exposed to outdoor temperatures.
- I. Install labels and nameplates on each control panel listing the name of the panel referenced in the graphics and a list of equipment numbers served by that panel.
- J. Furnish hydronic instrument wells, valves, and other accessories to the mechanical contractor for installation.

## 2.9 ELECTRICAL WIRING SCOPE

- A. This contractor shall not be responsible for power to control panels and control devices that are furnished by others, unless it is part of the control interlock wiring.
- B. Refer to Coordination section for what devices this contractor is responsible to mount and which are turned over to others to mount.
- C. This contractor shall be responsible for wiring of any control device that is furnished as part of this section of specification.
- D. Wiring for controls furnished by others:
  - 1. Provide control wiring for HVAC controls furnished by others. Wiring may include, but not limited to, interlocks, standalone thermostats, safeties and remote control devices such as valves, sensors, etc.
- E. Interlock wiring shall be run in separate conduits from BAS associated wiring.
- F. Provide network wiring for equipment that is called to be integrated to the BAS.

## 2.10 ELECTRICAL WIRING AND CONNECTION INSTALLATION

- A. All low voltage control wiring shall be class 2. Control wiring that is not class 2 shall be run in separate conduits from class 2 wiring.
- B. Floor level network wiring between terminal units can be combined with thermostat and other low voltage wiring in the same conduit. All other network wiring shall be in dedicated conduits.
- C. Install raceways, boxes, and cabinets according to Division 26 Section "Raceways and Boxes."
- D. Install building wire and cable according to Division 26 Section "Conductors and Cables."
- E. Installation shall meet the following requirements:
  - 1. Conceal cable and conduit, except in mechanical rooms and areas where other conduit and piping are exposed.
  - 2. Install exposed cable in raceway or conduit.
  - 3. Install concealed cable using plenum rated cable.
  - 4. Bundle and harness multiconductor instrument cable in place of single cables where several cables follow a common path.
  - 5. Fasten flexible conductors, bridging cabinets and doors, along hinge side; protect against abrasion. Tie and support conductors.
  - 6. Number-code or color-code conductors for future identification and service of control system, except local individual room control cables.
- F. Install conduit adjacent to machine to allow service and maintenance.

## 2.11 COMMUNICATION WIRING

- A. All cabling shall be installed in a neat and workmanlike manner. Follow manufacturer's installation recommendations for all communication cabling.
- B. Do not install communication wiring in raceway and enclosures containing Class 1 wiring.
- C. Maximum pulling, tension, and bend radius for cable installation, as specified by the cable manufacturer, shall not be exceeded during installation.
- D. Contractor shall verify the integrity of the entire network following the cable installation. Use appropriate test measures for each particular cable.
- E. Cable bundling:
  - 1. RS485 cabling run open air in accessible areas can be bundled with other class 2 low voltage cabling.
  - 2. RS485 cabling run between terminal units in conduits above ceilings or under floors or in inaccessible areas can be bundled with other class 2 low voltage cabling.
  - 3. RS485 cabling run between floors shall be in a communication only conduit.
  - 4. RS485 conduit run long distances between utility rooms or between buildings shall be in a communication only conduit.
  - 5. Ethernet cabling shall be in a communication only conduit.
  - 6. Ethernet and RS485 can be run together.
  - 7. Fiber optics can be run with Ethernet and RS485 cabling as long as the conduit is bent to fiber optic standards and junction boxes are sized for fiber optic use.

- F. FLN Cabling
  - 1. FLN cabling shall be low capacitance, 20-24 gauge, twisted shielded pair.
  - 2. The shields shall be tied together at each device.
  - 3. The shield shall be grounded at one end only and capped at the other end.
  
- G. Ethernet Cabling
  - 1. Ethernet shall not be run with any Class 1 or low voltage Class 2 wiring.
  - 2. CAT6, unshielded twisted pair (UTP) cable shall be used for BAS Ethernet.
  - 3. Solid wire shall be used for long runs, between mechanical rooms and between floors. Stranded cable can be used for patch cables and between panels in the same mechanical room up to 50 feet away.
  - 4. When the BAS Ethernet connects to an Owner's network switch, document the port number on the BAS As-builts.
  
- H. When a cable enters or exits a building, a lightning arrestor must be installed between the lines and ground. The lightning arrestor shall be installed according to the manufacturer's instructions.
  
- I. All runs of communication wiring shall be unspliced length when that length is commercially available.
  
- J. All communication wiring shall be labeled to indicate origination and destination data.
  
- K. Grounding of coaxial cable shall be in accordance with NEC regulations article on "Communications Circuits, Cable, and Protector Grounding."

## 2.12 IDENTIFICATION

- A. Match the existing wiring and conduit identification methods.

## 2.13 FIELD QUALITY CONTROL

- A. Manufacturer's Field Service: Engage a factory-authorized service representative to inspect field-assembled components and equipment installation, including piping and electrical connections. Report results in writing.
  - 1. Operational Test: After electrical circuitry has been energized, start units to confirm proper unit operation. Remove malfunctioning units, replace with new units, and retest.
  - 2. Test and adjust controls and safeties. Replace damaged and malfunctioning controls and equipment, and retest.
  - 3. Calibration test controllers by disconnecting input sensors and stimulating operation with compatible signal generator.
  
- B. Engage a factory-authorized service representative to perform startup service.
  
- C. Replace damaged or malfunctioning controls and equipment.
  - 1. Start, test, and adjust control systems.
  - 2. Demonstrate compliance with requirements, including calibration and testing, and control sequences.

3. Adjust, calibrate, and fine tune circuits and equipment to achieve sequence of operation specified.

#### 2.14 SYSTEM CHECKOUT AND STARTUP

- A. Inspect each termination in the MER control panels and devices to make sure all wires are connected according to the wiring diagrams and all termination are tight.
- B. After the controls devices and panels are installed and power is available to the controls, perform a static checkout of all the points, including the following:
  1. Inspect the setup and reading on each temperature sensor against a thermometer to verify its accuracy.
  2. Inspect the setup and reading on each humidity sensor against a hygrometer to verify its accuracy.
  3. Inspect the reading on each CO2 sensor using a calibration kit to verify the sensor range accuracy matches the DDC setup.
  4. Inspect the reading of each status switch to verify the DDC reads the open and close correctly.
  5. Command each relay to open and close to verify its operation.
  6. Command each 2-position damper actuator to open and close to verify operation.
  7. Command each 2-position valve to open and close to verify operation.
  8. Ramp each modulating actuator to 0%, 25%, 50%, 75% and 100% to verify its operation.
  9. Ramp each modulating output signal, such as a VFD speed, to verify its operation.
  10. Test each safety device with a real life simulation, for instance check freezestats with ice water, water detectors with water, etc.
- C. Document that each point was verified and operating correctly. Correct each failed point before proceeding to the dynamic startup.
- D. Verify that each DDC controller communicates on its respective network correctly.
- E. After all of the points are verified, and power is available to the mechanical system, coordinate a startup of each system with the mechanical contractor. Include the following tests:
  1. Start systems from DDC.
  2. Verify that each setpoint can be met by the system.
  3. Change setpoints and verify system response.
  4. Change sensor readings to verify system response.
  5. Test safety shutdowns.
  6. Verify time delays.
  7. Verify mode changes.
  8. Adjust filter switches and current switches for proper reactions.
  9. Adjust proportional bands and integration times to stabilize control loops.
- F. Perform all program changes and debugging of the system for a fully operational system.
- G. Verify that all graphics at the operator workstations correspond to the systems as installed. Verify that the points on the screens appear and react properly. Verify that all adjustable setpoints and manual commands operate from the operator workstations.
- H. After the sequence of operation is verified, setup the trends that are listed in the sequence of operations for logging and archiving for the commissioning procedure.

## 2.15 SYSTEM COMMISSIONING, DEMONSTRATION AND TURNOVER

- A. The BAS Contractor shall prepare and submit for approval a complete acceptance test procedure including submittal data relevant to point index, functions, sequence, interlocks, and associated parameters, and other pertinent information for the operating system. Prior to acceptance of the BAS by the Owner and Engineer, the BAS contractor shall completely test the BAS using the approved test procedure.
- B. After the BAS contractor has completed the tests and certified the BAS is 100% complete, the Engineer shall be requested, in writing, to approve the satisfactory operation of the system, sub-systems and accessories. The BAS contractor shall submit Maintenance and Operating manuals at this time for approval. An acceptance test in the presence of the Engineer and Owner's representative shall be performed. The Owner will then shake down the system for a fixed period of time (30 days).
- C. The BAS contractor shall fix punch list items within 30 days of acceptance.
- D. When the system performance is deemed satisfactory in whole or in part by these observers, the system parts will be accepted for beneficial use and placed under warranty.

## 2.16 PROJECT RECORD DOCUMENTS

- A. Project Record Documents: Submit three (3) copies of record (as-built) documents upon completion of installation. Submittal shall consist of:
  - 1. Project Record Drawings. As-built versions of the submittal shop drawings provided as AutoCAD compatible files in electronic format and as 11 x 17 inch prints.
  - 2. Testing and Commissioning Reports and Checklists. Completed versions of reports, checklists, and trend logs used to meet requirements in the Control System Demonstration and Acceptance section of this specification.
  - 3. Operation and Maintenance (O & M) Manual.
    - a. Operator's Manual with procedures for operating control systems, logging on and off, handling alarms, producing point reports, trending data, overriding computer control, and changing setpoints and variables.
    - b. Documentation of all programs created using custom programming language, including setpoints, tuning parameters, and object database.
    - c. Graphic files, programs, and database on electronic media.
    - d. List of recommended spare parts with part numbers and suppliers.
    - e. Licenses, guarantees, and warranty documents for equipment and systems.
- B. Provide updated versions of Operating manuals.

## 2.17 TRAINING

- A. At a time mutually agreed upon, during System commissioning as stated above, the BAS contractor shall give 4-hours of onsite training on the operation of all BAS equipment. Describe its intended use with respect to the programmed functions specified. Operator orientation of the automation system shall include, but not be limited to:
  - 1. Explanation of drawings and operator's maintenance manuals.
  - 2. Walk-through of the job to locate all control components.
  - 3. Operator workstation and peripherals.
  - 4. DDC Controller and ASC operation/sequence.

5. Operator control functions including scheduling, alarming, and trending.
6. Explanation of adjustment, calibration and replacement procedures.

### PART 3 - SEQUENCE OF OPERATION

#### 3.1 GENERAL:

- A. All mechanical equipment shall be monitored thru the DDC Control system with proof of flow devices. The run time of a monitored motors shall be available at the Facility Management System. Console. A maintenance alarm message shall be programmed at a specific run time as designated by the system operator. The alarm message shall be a designated by the operator.

#### 3.2 VAV ZONES WITH REHEAT COIL

- A. Occupied mode of the zone controller shall be determined by the central control. In the occupied mode if the space temperature is between the heating temperature and the cooling temperature set point, the box shall be in a dead band mode. The local DDC control loop shall modulate the primary damper to maintain the ventilation minimum CFM set point. On a fall in space temperature equal to the heating temperature set point, the controller shall then modulate the reheat coil as well as reset the supply air volume between the ventilation minimum and the heating maximum set point. The heating volume shall be a function of the heating calculation percentage to minimize the amount of reheat. On a 100% call for heat, the VAV box shall control to the maximum heating velocity set point and the control valve shall be wide open. A discharge sensor/control loop limits the supply air temperature 15° F above setpoint maximum programmable.
- B. The reverse shall occur on an increase in space temperature equal to or greater than the heating temperature set point. When the space temperature is equal to or greater than the cooling temperature set point the VAV box shall enter the cooling mode. The controller shall reset the box CFM set point from the minimum ventilation set point to the cooling maximum set point. If the zone CO2 level is above 800 ppm (adj), then the VAV box minimum shall be indexed upwards towards the cooling maximum, to meet the CO2 set point maximum.
- C. In the unoccupied mode the VAV box damper shall be closed and the reheat coil valve closed. On a fall in space temperature below the unoccupied heating set point the control valve shall open and the primary air damper shall control to the heating volume to maintain the night set back setting.
- D. All VAV and constant volume boxes in the system shall be equipped with discharge air temperature sensors and the FMCS shall monitor and display the discharge air temperature.
- E. When the zone is scheduled for occupancy and a motioned controlled lighting sensor by electrical contractor determines the space is vacant, the auxiliary contact in the motion sensor shall signal the VAV zone to go to zero ventilation minimum if there is no call for heating or cooling above 55° OSA temperature. Interlock wiring is by this contractor. See the mechanical HVAC drawings for locations where a VAV boxes serve one physical space. If a VAV box serves multiple spaces then the occupancy sensor located in each space will be connected in parallel and ties into the VAV box. If one space is occupied



the VAV box will operate to maintain space temperature. The interlock will occur where electrical has provided occupancy sensors for lighting control. See electrical.

END OF SECTION 23 0900

**SECTION 23 21 13 - HYDRONIC PIPING**

## PART 1 - GENERAL

## 1.1 RELATED DOCUMENTS

- A. Drawings and general provisions of the Contract, including General and Supplementary Conditions and Division 01 Specification Sections, apply to this Section.

## 1.2 SUMMARY

- A. Section includes pipe and fitting materials and joining methods for the following:
  - 1. Hot-water heating piping.
  - 2. Chilled-water piping.
  - 3. Air-vent piping.
  - 4. Dielectric fittings.

## 1.3 SEISMIC REQUIREMENTS

- A. Seismic Performance: Pipe hangers and supports shall withstand the effects of earthquake motions determined according to SEI/ASCE 7 and with the requirements specified in Section 230548 "Vibration and Seismic Controls for HVAC."
  - 1. For piping with a seismic importance factor of 1.0 the term "withstand" means "the system will remain in place without separation of any parts when subjected to the seismic forces specified."
  - 2. For piping with a seismic importance factor of 1.5 the term "withstand" means "the system will remain in place without separation of any parts when subjected to the seismic forces specified and the system will be fully operational after the seismic event."

## 1.4 ACTION SUBMITTALS

- A. Product Data: For each type of the following:
  - 1. Steel pipe and fittings.
  - 2. Copper pipe, tubing and fittings.
  - 3. Dielectric fittings.
- B. Delegated-Design Submittal:
  - 1. Design calculations and detailed fabrication and assembly of pipe anchors and alignment guides, hangers and supports for multiple pipes, expansion joints and loops, and attachments of the same to the building structure.
  - 2. Locations of pipe anchors and alignment guides and expansion joints and loops.

3. Locations of and details for penetrations, including sleeves and sleeve seals for exterior walls, floors, basement, and foundation walls.

#### 1.5 INFORMATIONAL SUBMITTALS

- A. Coordination Drawings: Piping layout, drawn to scale, on which the following items are shown and coordinated with each other, using input from installers of the items involved:
  1. Suspended ceiling components.
  2. Other building services.
  3. Structural members.
- B. Qualification Data: For Installer.
- C. Welding certificates.
- D. Field quality-control reports: Written reports as specified in Part 3 of this section including:
  1. Test procedures used.
  2. Test results showing compliance with specified requirements.
  3. Failed test results with corrective action taken to achieve compliance with specified requirements.

#### 1.6 QUALITY ASSURANCE

- A. Steel Support Welding: Qualify procedures and personnel according to AWS D1.1/D1.1M, "Structural Welding Code - Steel."
- B. Pipe Welding: Qualify procedures and operators according to ASME Boiler and Pressure Vessel Code: Section IX.
  1. Comply with ASME B31.9, "Building Services Piping," for materials, products, and installation.
  2. Certify that each welder has passed AWS qualification tests for welding processes involved and that certification is current.

#### 1.7 COORDINATION

- A. Coordinate layout and installation of hydronic piping and suspension system components with other construction, including light fixtures, HVAC equipment, fire-suppression-system components, and partition assemblies.
- B. Coordinate pipe sleeve installations for foundation wall penetrations.
- C. Coordinate piping installation with roof curbs, equipment supports, and roof penetrations. Roof specialties are specified in Division 7 Sections.
- D. Coordinate pipe fitting pressure classes with products specified in related sections.

- E. Coordinate size and location of concrete bases. Cast anchor-bolt inserts into base. Concrete, reinforcement, and formwork requirements are specified in Division 3 Sections.
- F. Coordinate installation of pipe sleeves for penetrations through exterior walls and floor assemblies. Coordinate with requirements for firestopping specified in Division 7 Section "Through-Penetration Firestop Systems" for fire and smoke wall and floor assemblies.

## PART 2 - PRODUCTS

### 2.1 COPPER TUBE AND FITTINGS

- A. Drawn-Temper Copper Tubing: ASTM B 88, Type L.

### 2.2 STEEL PIPE AND FITTINGS

- A. Steel Pipe: ASTM A 53, black steel with plain ends; welded and seamless, Grade B, and wall thickness as indicated in "Piping Applications" Article.
- B. Cast-Iron Threaded Fittings: ASME B16.4; Classes 125 and 250 as indicated in "Piping Applications" Article.
- C. Malleable-Iron Threaded Fittings: ASME B16.3, Classes 150 and 300 as indicated in "Piping Applications" Article.
- D. Malleable-Iron Unions: ASME B16.39; Classes 150, 250, and 300 as indicated in "Piping Applications" Article.
- E. Cast-Iron Pipe Flanges and Flanged Fittings: ASME B16.1, Classes 25, 125, and 250; raised ground face, and bolt holes spot faced as indicated in "Piping Applications" Article.
- F. Wrought-Steel Fittings: ASTM A 234, wall thickness to match adjoining pipe.
- G. Wrought Cast- and Forged-Steel Flanges and Flanged Fittings: ASME B16.5, including bolts, nuts, and gaskets of the following material group, end connections, and facings:
  - 1. Material Group: 1.1.
  - 2. End Connections: Butt welding.
  - 3. Facings: Raised face.
- H. Forged Steel "Olet" Type Fittings, Welding, Socket-Welding and Threaded: ASME B16.11 and ASTM A105.
  - 1. Welding Filler Metals: Comply with AWS D10.12M/D10.12 for welding materials appropriate for wall thickness and chemical analysis of steel pipe being welded.
- I. Steel Pipe Nipples: ASTM A 733, made of same materials and wall thicknesses as pipe in which they are installed.

## 2.3 JOINING MATERIALS

- A. Pipe-Flange Gasket Materials: Suitable for chemical and thermal conditions of piping system contents.
  - 1. ASME B16.21, nonmetallic, flat, asbestos free, 1/8-inch (3.2-mm) maximum thickness unless otherwise indicated.
    - a. Full-Face Type: For flat-face, Class 125, cast-iron and cast-bronze flanges.
    - b. Narrow-Face Type: For raised-face, Class 250, cast-iron and steel flanges.
- B. Flange Bolts and Nuts: ASME B18.2.1, carbon steel, unless otherwise indicated.
- C. Solder Filler Metals: ASTM B 32, lead-free alloys. Include water-flushable flux according to ASTM B 813.
- D. Brazing Filler Metals: AWS A5.8, BCuP Series, copper-phosphorus alloys for joining copper with copper; or BAg-1, silver alloy for joining copper with bronze or steel.
- E. Welding Filler Metals: Comply with AWS D10.12M/D10.12 for welding materials appropriate for wall thickness and chemical analysis of steel pipe being welded.

## 2.4 DIELECTRIC FITTINGS

- A. General: Assembly or fitting with insulating material isolating joined dissimilar metals, to prevent galvanic action and stop corrosion.
  - 1. Manufacturers:
    - a. Advance Products & Systems, Inc.
    - b. Calpico, Inc. Capitol Manufacturing Co.
    - c. Capitol Manufacturing Company.
    - d. Central Plastics Company.
    - e. Elster Perfection.
    - f. Grinnell Mechanical Products.
    - g. Matco-Norca.
    - h. Pipeline Seal and Insulator, Inc.
    - i. Precision Plumbing Products, Inc.
    - j. Victaulic Company.
    - k. Watts Regulator Co.
    - l. Zurn Industries, LLC.
- B. Description: Combination of copper alloy and ferrous; threaded, solder, plain, and weld-neck end types and matching piping system materials.
- C. Insulating Material: Suitable for system fluid, pressure, and temperature.
- D. End Connections: Threaded, or flanged.
- E. Dielectric Couplings: Galvanized-steel coupling with inert and noncorrosive, thermoplastic lining; threaded ends; and 300-psig minimum working pressure at 225 deg F.

- F. Dielectric Nipples or Waterways: Electroplated steel with inert and noncorrosive, thermoplastic lining; plain, threaded, or grooved ends; and 300-psig minimum working pressure at 225 deg F.

### PART 3 - EXECUTION

#### 3.1 PIPING APPLICATIONS

- A. Hot-water heating piping, aboveground, NPS 2 and smaller shall be any of the following:
  - 1. Type L drawn-temper copper tubing, wrought-copper fittings, and soldered joints.
  - 2. Schedule 40, Grade B, Type 96 steel pipe; Class 125, cast-iron fittings; cast-iron flanges and flange fittings; and threaded joints.
- B. Hot-water heating piping, aboveground, NPS 2-1/2 and larger, shall be any of the following:
  - 1. Type L, drawn-temper copper tubing, wrought-copper fittings, and soldered joints.
  - 2. Schedule 40 steel pipe, wrought-steel fittings and wrought-cast or forged-steel flanges and flange fittings, and welded and flanged joints.
- C. Chilled-water piping, aboveground, NPS 2 and smaller, shall be any of the following:
  - 1. Type L, drawn-temper copper tubing, wrought-copper fittings, and soldered joints.
  - 2. Schedule 40, Grade B, Type 96 steel pipe; Class 125, cast-iron fittings; cast-iron flanges and flange fittings; and threaded joints.
- D. Chilled-water piping, aboveground, NPS 2-1/2 and larger, shall be any of the following:
  - 1. Type L, drawn-temper copper tubing, wrought-copper fittings, and soldered joints.
  - 2. Schedule 40 steel pipe, wrought-steel fittings and wrought-cast or forged-steel flanges and flange fittings, and welded and flanged joints.
- E. Glycol cooling-water piping, aboveground, NPS 2 and smaller, shall be any of the following:
  - 1. Type L, drawn-temper copper tubing, wrought-copper fittings, and soldered joints.
  - 2. Schedule 40, Grade B, Type 96 steel pipe; Class 125, cast-iron fittings; cast-iron flanges and flange fittings; and threaded joints.
- F. Glycol cooling-water piping, aboveground, NPS 2-1/2 and larger, shall be any of the following:

1. Type L, drawn-temper copper tubing, wrought-copper fittings, and soldered joints.
  2. Schedule 40 steel pipe, wrought-steel fittings and wrought-cast or forged-steel flanges and flange fittings, and welded and flanged joints.
- G. Condensate-drain piping shall be the following:
1. Type M, drawn-temper copper tubing, wrought-copper fittings, and soldered joints.
- H. Blowdown-Drain Piping: Same materials and joining methods as for piping specified for the service in which blowdown drain is installed.
- I. Air-Vent Piping:
1. Inlet: Same as service where installed with metal-to-plastic transition fittings for plastic piping systems according to piping manufacturer's written instructions.
  2. Outlet: Type K, annealed-temper copper tubing with soldered or flared joints.
- J. Safety-Valve-Inlet and -Outlet Piping for Hot-Water Piping: Same materials and joining methods as for piping specified for the service in which safety valve is installed with metal-to-plastic transition fittings for plastic piping systems according to piping manufacturer's written instructions.

### 3.2 PIPING INSTALLATIONS

#### A. PRE-WORK / PRE-REQUISITES

1. Drawing plans, schematics, and diagrams indicate general location and arrangement of piping systems. Install piping as indicated unless deviations to layout are approved on Coordination Drawings.
2. The Contractor shall study the architectural, structural, mechanical, electrical and other drawings to eliminate conflict of piping with other structure lighting or other services.

#### B. CONDITION

1. All installed pipe lines shall be free from dents, scars, and burrs, with ends reamed smooth.
2. All piping shall be clean and free from acids and loose dirt when installed and shall be kept clean during the completion of the installation.
3. Install piping free of sags and bends.
4. All installed pipe lines shall remain straight against strains tending to cause distortion during system operation. The contractor shall make proper allowance for pipe line expansion and contraction so that no unsightly distortion, noise, damage or improper operation results therefrom.

## C. SELECTION

1. Select system components with pressure rating equal to or greater than system operating pressure.
2. No street type fittings shall be used.
3. No short nipples shall be used except at drain valves.
4. Plugs of rags, wools, cottons, waste, or similar materials may not be used for plugging.

## D. ROUTING/ARRANGEMENT

1. Piping installations shall be neatly organized.
2. Install piping in concealed locations unless otherwise indicated and except in equipment rooms and service areas.
3. Install groups of pipes parallel to each other.
4. Install piping spaced to permit application of insulation.
5. Install piping parallel and spaced to permit the servicing of valves.
6. Install piping indicated to be exposed and piping in equipment rooms and service areas at right angles or parallel to building walls or axis of the building.
7. Diagonal runs are prohibited unless specifically indicated otherwise.
8. Install fittings for all changes in direction.
9. No piping shall be run above any electrical panels, electrical equipment or access clearances for electrical for electrical panels or equipment. No piping shall be allowed to run through any electrical rooms.
10. Piping shall be arranged, placed and installed to facilitate equipment maintenance and shall be so arranged to not interfere with the installation of the air-conditioning equipment, ducts, or the removal of other equipment or devices. All specialties shall be so placed to permit easy operation and access.
11. All piping shall be so installed to insure noiseless circulation.
12. Install fittings for all branch connections.
13. Unless otherwise indicated, install branch connections to mains using tee fittings or forged steel branch fittings in main pipe, with the branch connected to the bottom of the main pipe.
14. For up-feed risers, connect the branch to the top of the main pipe.
15. Forged branch fittings shall be installed per the manufacturer's recommendations.



## E. ACCESS / ARRANGEMENT

1. Install piping above accessible ceilings to allow sufficient space for ceiling panel removal. All piping shall be so arranged to not block access to manholes, access openings, etc.
2. Install piping at indicated slopes. If not indicated, install piping at a uniform grade of 0.2 percent where possible, upward in direction of flow. Traps are to be avoided where-ever possible.
3. Reduce pipe sizes using eccentric reducer fitting installed with level side up.
4. When insulated pipes are supported by a roller hanger they shall be protected from damage by suitable pipe covering protection saddles. Saddles shall support pipe on roller and shall be packed with insulation.
5. Install valves according to Section 230523 "General-Duty Valves for HVAC Piping."
6. Install unions in piping, NPS 2 and smaller, adjacent to valves, at final connections of equipment, at each coil on all sides of automatic valves where valves do not have union connections, elsewhere as indicated, and wherever necessary to prevent undue difficulty in making repairs or replacement. Unions are not required at flanged connections.
7. Install flanges in piping, NPS 2-1/2 and larger, at final connections of equipment and elsewhere as indicated. Install flanges on valves, apparatus, and equipment having 2 ½ inch NPS and larger connections. Flanges or unions as applicable for the type of piping specified, shall be provided in the piping at connections to all items of equipment.
8. Install shutoff valve immediately upstream of each dielectric fitting. Install dielectric coupling and nipple fittings to connect piping materials of dissimilar metals.
9. Comply with requirements in Section 230516 "Expansion Fittings and Loops for HVAC Piping" for installation of expansion loops, expansion joints, anchors, and pipe alignment guides. Anchor piping for proper direction of expansion and contraction.
10. Install sleeves for piping penetrations of walls, ceilings, and floors. Comply with requirements for sleeves specified in Section 230517 "Sleeves and Sleeve Seals for HVAC Piping."
11. Install sleeve seals for piping penetrations of concrete walls and slabs. Comply with requirements for sleeve seals specified in Section 230517 "Sleeves and Sleeve Seals for HVAC Piping."
12. Install escutcheons for piping penetrations of walls, ceilings, and floors. Comply with requirements for escutcheons specified in Section 230518 "Escutcheons for HVAC Piping."
13. Install strainers on supply side of each control valve, pressure-reducing valve, solenoid valve, in-line pump, and elsewhere as indicated. Install NPS ¾) nipple

and ball valve in blow-down connection of strainers NPS 2) and larger. Match size of strainer blow-off connection for strainers smaller than NPS 2).

14. Install flexible connectors at inlet and discharge connections to pumps (except inline pumps) and other vibration-producing equipment.
15. Polypropylene pipe in or passing through plenums must be fire wrapped or installed in a metal conduit.

#### F. DRAINAGE

1. Drain valves shall be installed at all low points in all piping systems to allow for complete drainage of piping systems.
2. Install drains, consisting of a tee fitting, NPS 3/4 ball valve, and short NPS 3/4 threaded nipple with cap, at low points in piping system mains and elsewhere as required for system drainage.
3. All piping systems shall be installed so that they can be easily drained by means of drainage of low points of all piping without disconnecting pipe.
4. If not specifically indicated on the drawings, the frequency of draining shall determine whether drain caps, plugs, cocks, or valves are to be used.

#### G. IDENTIFICATION

1. Comply with requirements in Section 230553 "Identification for HVAC Piping and Equipment" for identifying piping.

### 3.3 DIELECTRIC FITTING INSTALLATION

#### A. Make connections according to the following, unless otherwise indicated:

1. Install dielectric nipples or waterways in piping NPS 2 and smaller, adjacent to each valve and at final connection to each piece of equipment.
2. Install waterways, in piping NPS 2-1/2 and larger, adjacent to flanged valves and at final connection to each piece of equipment.
3. Install Dielectric Fittings into Hydronic Piping Systems: Install dielectric nipples, waterways or couplings to connect piping materials of dissimilar metals.
4. End Connections: Threaded, or flanged.

### 3.4 HANGERS AND SUPPORTS

- #### A.
- Comply with requirements in Section 230529 "Hangers and Supports for HVAC Piping and Equipment" for hanger, support, and anchor devices. Comply with the following requirements for maximum spacing of supports.

- B. Comply with requirements in Section 230548 "Vibration and Seismic Controls for HVAC" for seismic restraints.
  - C. Steel roof deck shall not be used to support loads from piping, ductwork or equipment, unless noted otherwise. Hanger loads less than 50 lbs. may be hung from the steel roof deck in cases when hanging from the steel roof deck cannot be avoided; the attachment method must distribute the load across the deck as approved by the Structural Engineer.
  - D. Install the following pipe attachments:
    - 1. Adjustable steel clevis hangers for individual horizontal piping less than 20 feet long.
    - 2. Adjustable roller hangers and spring hangers for individual horizontal piping 20 feet or longer.
    - 3. Pipe Roller: MSS SP-58, Type 44 for multiple horizontal piping 20 feet or longer, supported on a trapeze.
    - 4. Spring hangers to support vertical runs.
    - 5. Provide copper-clad hangers and supports for hangers and supports in direct contact with copper pipe.
    - 6. On plastic pipe, install pads or cushions on bearing surfaces to prevent hanger from scratching pipe.
  - E. Install hangers for steel piping with the following maximum spacing and minimum rod sizes:
    - 1. NPS 3/4: Maximum span, 7 feet; minimum rod size, 3/8 inch.
    - 2. NPS 1: Maximum span, 7 feet; minimum rod size, 3/8 inch.
    - 3. NPS 1-1/2: Maximum span, 9 feet; minimum rod size, 3/8 inch.
    - 4. NPS 2: Maximum span, 10 feet; minimum rod size, 3/8 inch.
    - 5. NPS 2-1/2: Maximum span, 11 feet; minimum rod size, 1/2 inch.
    - 6. NPS 3 and Larger: Maximum span, 12 feet; minimum rod size, 1/2 inch.
  - F. Install hangers for drawn-temper copper piping with the following maximum spacing and minimum rod sizes:
    - 1. NPS 3/4: Maximum span, 5 feet; minimum rod size, 1/4 inch.
    - 2. NPS 1: Maximum span, 6 feet; minimum rod size, 1/4 inch.
    - 3. NPS 1-1/4: Maximum span, 7 feet; minimum rod size, 3/8 inch.
    - 4. NPS 1-1/2: Maximum span, 8 feet; minimum rod size, 3/8 inch.
    - 5. NPS 2: Maximum span, 8 feet; minimum rod size, 3/8 inch.
    - 6. NPS 2-1/2: Maximum span, 9 feet; minimum rod size, 3/8 inch.
    - 7. NPS 3 and Larger: Maximum span, 10 feet; minimum rod size, 3/8 inch.
  - G. Support vertical runs at roof, at each floor, and at 10-foot intervals between floors.
  - H. Support piping and tubing not listed in this article according to MSS SP-69 and manufacturer's written instructions.
- 3.5 PIPE JOINT CONSTRUCTION
- A. Ream ends of pipes and tubes and remove burrs. Bevel plain ends of steel pipe.

- B. Remove scale, slag, dirt, and debris from inside and outside of pipe and fittings before assembly.
- C. Soldered Joints: Apply ASTM B 813, water-flushable flux, unless otherwise indicated, to tube end. Construct joints according to ASTM B 828 or CDA's "Copper Tube Handbook," using lead-free solder alloy complying with ASTM B 32.
- D. Brazed Joints: Construct joints according to AWS's "Brazing Handbook," "Pipe and Tube" Chapter, using copper-phosphorus brazing filler metal complying with AWS A5.8.
- E. Threaded Joints: Thread pipe with tapered pipe threads according to ASME B1.20.1. Cut threads full and clean using sharp dies. Ream threaded pipe ends to remove burrs and restore full ID. Join pipe fittings and valves as follows:
  - 1. Apply appropriate tape or thread compound to external pipe threads unless dry seal threading is specified.
  - 2. Damaged Threads: Do not use pipe or pipe fittings with threads that are corroded or damaged. Do not use pipe sections that have cracked or open welds.
- F. Welded Joints: Construct joints according to AWS D10.12M/D10.12, using qualified processes and welding operators according to "Quality Assurance" Article.
- G. Flanged Joints: Select appropriate gasket material, size, type, and thickness for service application. Install gasket concentrically positioned. Use suitable lubricants on bolt threads.

### 3.6 TERMINAL EQUIPMENT CONNECTIONS

- A. Sizes for supply and return piping connections shall be the same as or larger than equipment connections.
- B. Install control valves in accessible locations close to connected equipment.

### 3.7 FIELD QUALITY CONTROL

- A. Prepare hydronic piping according to ASME B31.9 and as follows:
  - 1. Leave joints, including welds, uninsulated and exposed for examination during test.
  - 2. Provide temporary restraints for expansion joints that cannot sustain reactions due to test pressure. If temporary restraints are impractical, isolate expansion joints from testing.
  - 3. Flush hydronic piping systems with clean water; then remove and clean or replace strainer screens.
  - 4. Isolate equipment from piping. If a valve is used to isolate equipment, its closure shall be capable of sealing against test pressure without damage to valve. Install blinds in flanged joints to isolate equipment.
  - 5. Install safety valve, set at a pressure no more than one-third higher than test pressure, to protect against damage by expanding liquid or other source of overpressure during test.

- B. Perform the following tests on hydronic piping:
1. Use ambient temperature water as a testing medium unless there is risk of damage due to freezing. Another liquid that is safe for workers and compatible with piping may be used.
  2. While filling system, use vents installed at high points of system to release air. Use drains installed at low points for complete draining of test liquid.
  3. Isolate expansion tanks and determine that hydronic system is full of water.
  4. Subject piping system to hydrostatic test pressure that is not less than 1.5 times the system's working pressure. Test pressure shall not exceed maximum pressure for any vessel, pump, valve, or other component in system under test. Verify that stress due to pressure at bottom of vertical runs does not exceed 90 percent of specified minimum yield strength or 1.7 times the "SE" value in Appendix A in ASME B31.9, "Building Services Piping."
  5. After hydrostatic test pressure has been applied for at least 10 minutes, examine piping, joints, and connections for leakage. Eliminate leaks by tightening, repairing, or replacing components, and repeat hydrostatic test until there are no leaks.
  6. Prepare written report of testing.
- C. Perform the following before operating the system:
1. Open manual valves fully.
  2. Inspect pumps for proper rotation.
  3. Set makeup pressure-reducing valves for required system pressure.
  4. Inspect air vents at high points of system and determine if all are installed and operating freely (automatic type), or bleed air completely (manual type).
  5. Set temperature controls so all coils are calling for full flow.
  6. Inspect and set operating temperatures of hydronic equipment, such as boilers, chillers, cooling towers, to specified values.
  7. Verify lubrication of motors and bearings.

END OF SECTION

**SECTION 23 21 16 - HYDRONIC PIPING SPECIALTIES**

## PART 1 - GENERAL

## 1.2 RELATED DOCUMENTS

- A. Drawings and general provisions of the Contract, including General and Supplementary Conditions and Division 01 Specification Sections, apply to this Section.

## 1.2 SUMMARY

- A. Section includes special-duty valves and specialties for the following:
  - 1. Hot-water heating piping.
  - 2. Chilled-water piping.
  - 3. Condensate-drain piping.
  - 4. Air-vent piping.
  - 5. Glycol cooling-water piping.

## 1.3 ACTION SUBMITTALS

- A. Product Data: For each type of the following:
  - 1. Valves: Include flow and pressure drop curves based on manufacturer's testing for calibrated-orifice balancing valves and automatic flow-control valves.
  - 2. Air-control devices.
  - 3. Hydronic specialties.

## 1.4 CLOSEOUT SUBMITTALS

- A. Operation and Maintenance Data: For air-control devices, hydronic specialties, and special-duty valves to include in emergency, operation, and maintenance manuals.

## 1.5 QUALITY ASSURANCE

- A. Pipe Welding: Qualify procedures and operators according to ASME Boiler and Pressure Vessel Code: Section IX.
  - 1. Safety valves and pressure vessels shall bear the appropriate ASME label. Fabricate and stamp air separators and expansion tanks to comply with ASME Boiler and Pressure Vessel Code: Section VIII, Division 1.

## PART 2 - PRODUCTS

## 2.1 VALVES

- A. Globe, Check, Ball, and Butterfly Valves: Comply with requirements specified in Section 230523 "General-Duty Valves for HVAC Piping. Gate valves are not allowed on this project.
- B. Automatic Temperature-Control Valves, Actuators, and Sensors: Comply with requirements specified in Section 230900 "Instrumentation and Control for HVAC.
- C. Refer to Part 3 "Valve Applications" Article for applications of each valve.
- D. Bronze, Calibrated-Orifice or Venturi, Balancing Valves, NPS 2 and smaller:
  - 1. Manufacturers: Subject to compliance with requirements, provide products by one of the following:
    - a. Armstrong Pumps, Inc.
    - b. Bell & Gossett Domestic Pump.
    - c. Flow Design Inc.
    - d. Gerand Engineering Co.
    - e. Griswold Controls.
    - f. Taco.
    - g. Tour & Andersson; available through Victaulic Company.
    - h. Tyco-Grinnell
  - 2. Body: Bronze, ball or plug type with calibrated orifice or venturi.
  - 3. Ball: Brass or stainless steel.
  - 4. Plug: Resin.
  - 5. Seat: PTFE.
  - 6. End Connections: Threaded or socket.
  - 7. Pressure Gage Connections: Integral seals for portable differential pressure meter.
  - 8. Handle Style: Lever, with memory stop to retain set position.
  - 9. CWP Rating: Minimum 125 psig.
  - 10. Maximum Operating Temperature: 250 deg F.
- E. Cast-Iron or Steel, Calibrated-Orifice or Venturi, Balancing Valves, NPS 2 ½ and larger:
  - 1. Manufacturers: Subject to compliance with requirements, provide products by one of the following:
    - a. Amtrol, Inc.
    - b. Armstrong Pumps, Inc.
    - c. Bell & Gossett Domestic Pump.
    - d. Flow Design Inc.
    - e. Gerand Engineering Co.
    - f. Grinnell.
    - g. Griswold Controls.
    - h. Taco.
      - i. Tour & Andersson; available through Victaulic Company.

- j. Spence Engineering Company Inc.
  - k. Watts Regulator Co.
2. Body: Cast-iron or steel body, ball, plug, or globe pattern with calibrated orifice or aperture.
  3. Ball: Brass or stainless steel.
  4. Stem Seals: EPDM O-rings.
  5. Disc: Glass and carbon-filled PTFE.
  6. Seat: PTFE.
  7. End Connections: Flanged or grooved.
  8. Pressure Gage Connections: Integral seals for portable differential pressure meter.
  9. Handle Style: Lever, with memory stop to retain set position.
  10. CWP Rating: Minimum 125 psig.
  11. Maximum Operating Temperature: 250 deg F.
- F. Diaphragm-Operated, Pressure-Reducing Valves: ASME labeled.
1. Manufacturers: Subject to compliance with requirements, provide products by one of the following:
    - a. Amtrol, Inc.
    - b. Armstrong Pumps, Inc.
    - c. Bell & Gossett Domestic Pump.
    - d. Conbraco Industries, Inc.
    - e. Spence Engineering Company, Inc.
    - f. Watts Regulator Co.
  2. Body: Bronze or brass.
  3. Disc: Glass and carbon-filled PTFE.
  4. Seat: Brass.
  5. Stem Seals: EPDM O-rings.
  6. Diaphragm: EPT.
  7. Low inlet-pressure check valve.
  8. Inlet Strainer: Brass, removable without system shutdown.
  9. Valve Seat and Stem: Noncorrosive.
  10. Valve Size, Capacity, and Operating Pressure: Selected to suit system in which installed, with operating pressure and capacity factory set and field adjustable.
- G. Diaphragm-Operated Safety Valves: ASME labeled.
1. Manufacturers: Subject to compliance with requirements, provide products by one of the following:
    - a. Amtrol, Inc.
    - b. Armstrong Pumps, Inc.
    - c. Bell & Gossett Domestic Pump.
    - d. Conbraco Industries, Inc.
    - e. Kunkle.
    - f. Spence Engineering Company, Inc.
  2. Body: Bronze or brass.



3. Disc: Glass and carbon-filled PTFE.
4. Seat: Brass.
5. Stem Seals: EPDM O-rings.
6. Diaphragm: EPT.
7. Wetted, Internal Work Parts: Brass and rubber.
8. Inlet Strainer: Brass, removable without system shutdown.
9. Valve Seat and Stem: Noncorrosive.
10. Valve Size, Capacity, and Operating Pressure: Comply with ASME Boiler and Pressure Vessel Code: Section IV, and selected to suit system in which installed, with operating pressure and capacity factory set and field adjustable.

#### H. Automatic Flow-Control Valves:

1. Manufacturers: Subject to compliance with requirements, provide products by one of the following:
  - a. Armstrong Pumps, Inc.
  - b. Bell & Gossett Domestic Pump.
  - c. Flow Design Inc.
  - d. Griswold Controls.
  - e. Taco
2. Body: Brass or ferrous metal.
3. Piston and Spring Assembly: Tamper proof, self-cleaning, and removable, for inspections and replacement.
  - a. Corrosion resistant.
4. Combination Assemblies: Include bronze or brass-alloy ball valve.
5. Identification Tag: Attached by chain and marked with zone identification, valve number, and flow rate.
6. Size: Same as pipe in which installed.
7. Performance: Maintain constant flow, plus or minus 5 percent over system pressure fluctuations:
  - a. Minimum CWP Rating: 175 psig.
8. Maximum Operating Temperature: 200 deg F.
9. Fitted with pressure and temperature test valves.
10. Equipped with a readout kit including flow meter, probes, hoses, flow charts, and carrying case.

## 2.2 AIR-CONTROL DEVICES

### A. Manual Air Vents:

1. Manufacturers: Subject to compliance with requirements, provide products by one of the following:
  - a. Amtrol, Inc.
  - b. Armstrong Pumps, Inc.
  - c. Bell & Gossett Domestic Pump.
  - d. Taco, Inc.

2. Body: Bronze.
  3. Internal Parts: Nonferrous.
  4. Operator: Screwdriver or thumbscrew.
  5. Manually operated with ball valve in the down position.
  6. Inlet Connection: NPS 1/2.
  7. Discharge Connection: NPS 1/8.
  8. CWP Rating: 150 psig.
  9. Maximum Operating Temperature: 225 deg F.
- B. Automatic Air Vents:
1. Manufacturers: Subject to compliance with requirements, provide products by one of the following:
    - a. Amtrol, Inc.
    - b. Bell & Gossett Domestic Pump.
    - c. Hoffman Specialty ITT; Fluid Handling Div.
    - d. Spirax-Sarco.
    - e. Spirovent.
    - f. Taco, Inc.
    - g. Honeywell-Baukman.
  2. Body: Bronze or cast iron.
  3. Internal Parts: Nonferrous.
  4. Operator: Noncorrosive metal float.
  5. Inlet Connection: NPS 1/2.
  6. Discharge Connection: NPS 1/4.
  7. CWP Rating: 150 psig.
  8. Maximum Operating Temperature: 240 deg F.
- C. Tangential-Type Air Separators:
1. Manufacturers: Subject to compliance with requirements, provide products by one of the following:
    - a. Amtrol, Inc.
    - b. Armstrong Pumps, Inc.
    - c. Bell & Gossett Domestic Pump.
    - d. Taco, Inc.
  2. Tank: Welded steel; ASME constructed and labeled for 125-psig minimum working pressure and 240 deg F maximum operating temperature.
  3. Air Collector Tube: Perforated stainless steel, constructed to direct released air into expansion tank.
  4. Tangential Inlet and Outlet Connections: Threaded for NPS 2 and smaller; flanged connections for NPS 2-1/2 and larger.
  5. Blowdown Connection: Threaded.
  6. Size: Match system flow capacity.

## 2.3 HYDRONIC PIPING SPECIALTIES

## A. Y-Pattern Strainers:

1. Manufacturers: Subject to compliance with requirements, provide products by one of the following:
  - a. Armstrong Machine Works.
  - b. Hoffman Specialty ITT; Fluid Handling Div.
  - c. Metraflex Co.
  - d. Mueller
  - e. Spirax Sarco.
  - f. Trane Co.
  - g. Tyco-Grinnell.
  - h. Tour & Andersson; available through Victaulic Company.
  - i. Watts Regulator Co.
2. Body: ASTM A 126, Class B, cast iron with bolted cover and bottom drain connection.
3. End Connections: Threaded ends for NPS 2 and smaller; flanged ends for NPS 2-1/2 and larger.
4. Strainer Screen: Stainless-steel, or perforated stainless-steel basket:
  - a. 20-mesh strainer.
5. CWP Rating: 125 psig.

## B. Basket Strainers:

1. Manufacturers: Subject to compliance with requirements, provide products by one of the following:
  - a. Crane Co.
  - b. Metraflex Co.
  - c. Mueller
  - d. Spirax Sarco.
  - e. Tyco-Grinnell.
  - f. Tour & Andersson; available through Victaulic Company.
2. Body: ASTM A 126, Class B, high-tensile cast iron with bolted cover and bottom drain connection.
3. End Connections: Threaded ends for NPS 2 and smaller; flanged ends for NPS 2-1/2 and larger.
4. Strainer Screen: Perforated stainless-steel basket with 50 percent free area:
  - a. 40-mesh startup strainer.
5. CWP Rating: 125 psig.

## C. Spherical, Rubber, Flexible Connectors:

1. Manufacturers: Subject to compliance with requirements, provide products by one of the following:
  - a. Amber-Booth.

- b. Mason Industries.
  - c. Metraflex Co.
  - d. Flex-Weld.
  - e. Proco.
  - f. Fugate.
  - g. Twin City Hose.
2. Body: Double-sphere fiber-reinforced EPDM rubber body.
  3. End Connections: Steel flanges drilled to align with Classes 150 and 300 steel flanges.
  4. Performance: Capable of misalignment.
  5. CWP Rating: 150 psig.
  6. Maximum Operating Temperature: 250 deg F.
- D. Diverting Fittings:
1. Manufacturers: Subject to compliance with requirements, provide products by one of the following:
    - a. Amtrol, Inc.
    - b. Armstrong Pumps, Inc.
    - c. Bell & Gossett Domestic Pump.
    - d. Taco, Inc.
  2. Body: Cast Iron or Wrought Copper
  3. Ends: Threaded or Soldered
  4. Flow Direction: Indicated on fitting.
  5. CWP Rating: 125 psig.
  6. Maximum Operating Temperature: 250 deg F.

## PART 3 - EXECUTION

### 3.1 VALVE APPLICATIONS

- A. Install shutoff-duty valves at each branch connection to supply mains and at supply connection to each piece of equipment.
- B. Install calibrated-orifice, balancing valves at each branch connection to return main.
- C. Install calibrated-orifice, balancing valves in the return pipe of each heating or cooling terminal.
- D. Install check valves at each pump discharge and elsewhere as required to control flow direction.
- E. Install safety valves at hot-water generators and elsewhere as required by ASME Boiler and Pressure Vessel Code. Install drip-pan elbow on safety-valve outlet and pipe without valves to the outdoors; pipe drain to nearest floor drain or as indicated on Drawings. Comply with ASME Boiler and Pressure Vessel Code: Section VIII, Division 1, for installation requirements.

- F. Install pressure-reducing valves at makeup-water connection to regulate system fill pressure.

### 3.2 HYDRONIC SPECIALTIES

- A. Install manual air vents at high points in piping, at heat-transfer coils, and elsewhere as required for system air venting.
- B. Automatic air vents may cause damage to ceilings and other finished surfaces. Air vents aid in system filling. Air removal after initial startup is accomplished by air separator or boiler diptube. Manual air vents may be a better solution.
- C. Install automatic air vents at high points of system piping in mechanical equipment rooms only. Install manual vents at heat-transfer coils and elsewhere as required for air venting.
- D. Install piping from boiler air outlet, air separator, or air purger to expansion tank with a 2 percent upward slope toward tank.
- E. Install in-line air separators in pump suction. Install drain valve on air separators NPS 2 and larger.
- F. Install tangential air separator in pump suction. Install blowdown piping with full-port ball valve; extend full size to nearest floor drain.
- G. Install expansion tanks above the air separator. Install tank fitting in tank bottom and charge tank. Use manual vent for initial fill to establish proper water level in tank.
  - 1. Install tank fittings that are shipped loose.
  - 2. Support tank from floor or structure above with sufficient strength to carry weight of tank, piping connections, fittings, plus tank full of water. Do not overload building components and structural members.
- H. Install expansion tanks on the floor. Vent and purge air from hydronic system, and ensure that tank is properly charged with air to suit system Project requirements.

END OF SECTION

**SECTION 23 30 01 - COMMON DUCT REQUIREMENTS**

## PART 1 - PRODUCTS

## 1.1 SUMMARY

## A. Includes But Not Limited To:

1. General procedures and requirements for ductwork.
2. Repair leaks in ductwork, as identified by smoke test, at no additional cost to Owner.
3. Soundproofing procedures for duct penetrations of walls, ceilings, and floors in mechanical equipment rooms.

## B. Related Sections:

1. Division 07: Quality of Acoustic Sealant.
2. Section 23 0500: Common Work Results for HVAC
3. Section 23 0593: Testing Adjusting and Balancing for HVAC.

## 1.2 SUBMITTALS

## A. Samples: Sealer and gauze proposed for sealing ductwork.

## B. Quality Assurance / Control:

1. Manufacturer's installation manuals providing detailed instructions on assembly, joint sealing, and system pressure testing for leaks.
2. Specification data on sealer and gauze proposed for sealing ductwork.

## 1.3 QUALITY ASSURANCE

## A. Requirements: Construction details not specifically called out in Contract Documents shall conform to applicable requirements of SMACNA HVAC Duct Construction Standards.

## B. Pre-Installation Conference: Schedule conference immediately before installation of ductwork.

## PART 2 - PRODUCTS

- 2.1 Finishes, Where Applicable: Colors as selected by Architect.
- 2.2 Duct Hangers:
- A. One inch by 18 ga galvanized steel straps or steel rods as shown on Drawings, and spaced not more than 96 inches apart. Do not use wire hangers.
    - 1. Attaching screws at trusses shall be 2 inch No. 10 round head wood screws. Nails not allowed.
    - 2. Attach threaded rod to steel joist with Grinnell Steel washer plate Fig. 60 - ph-1. Double nut connection.
- 2.3 Penetration Soundproofing Materials:
- A. Insulation for Packing: Fiberglass.
  - B. Calking: Polysulphide.
  - C. Escutcheon Frame: 22 ga galvanized iron 2 inches wide.

## PART 3 - EXECUTION

- 3.1 INSTALLATION
- A. During installation, protect open ends of ducts by covering with plastic sheet tied in place to prevent entrance of debris and dirt.
  - B. Make necessary allowances and provisions in installation of sheet metal ducts for structural conditions of building. Revisions in layout and configuration may be allowed, with prior written approval of Architect. Maintain required airflows in suggesting revisions.
  - C. Hangers And Supports:
    - 1. Install pair of hangers close to each transverse joint and elsewhere as required by spacing indicated in table on Drawings.
    - 2. Install upper ends of hanger securely to floor or roof construction above by method shown on Drawings.
    - 3. Attach strap hangers to ducts with cadmium-plated screws. Use of pop rivets or other means will not be accepted.
    - 4. Where hangers are secured to forms before concrete slabs are poured, cut off flush all nails, strap ends, and other projections after forms are removed.
    - 5. Secure vertical ducts passing through floors by extending bracing angles to rest firmly on floors without loose blocking or shimming. Support vertical ducts, which do not pass through floors, by using bands bolted to walls, columns, etc. Size, spacing, and method of attachment to vertical ducts shall be same as specified for hanger bands on horizontal ducts.

D. Penetration Soundproofing

1. Pack space between ducts and structure full of fiberglass insulation of sufficient thickness to be wedged tight, allowing space for application of caulking.
2. Provide caulking at least 2 inches thick between duct and structure on both ends of opening through structure.
3. Provide metal escutcheon on Equipment Room side. Secure escutcheon to wall.

3.2 CLEANING

- A. Clean interior of duct systems before final completion.

END OF SECTION



**SECTION 23 31 13 - METAL DUCTS**

## PART 1 - GENERAL

## 1.1 RELATED DOCUMENTS

- A. Drawings and general provisions of the Contract, including General and Supplementary Conditions and Division 01 Specification Sections, apply to this Section.

## 1.2 SUMMARY

- A. Section Includes:

1. Single-wall rectangular ducts and fittings.
2. Single-wall round and flat-oval ducts and fittings.
3. Sheet metal materials.
4. Duct liner.
5. Sealants and gaskets.
6. Hangers and supports.

- B. Related Sections:

1. Section 230593 "Testing, Adjusting, and Balancing for HVAC" for testing, adjusting, and balancing requirements for metal ducts.
2. Section 233300 "Air Duct Accessories" for dampers, sound-control devices, duct-mounting access doors and panels, turning vanes, and flexible ducts.
3. Section 230713 "Duct Insulation" for duct insulation and fire wrap.

## 1.3 PERFORMANCE REQUIREMENTS

- A. Delegated Duct Design: Duct construction, including sheet metal thicknesses, seam and joint construction, reinforcements, and hangers and supports, shall comply with SMACNA's "HVAC Duct Construction Standards - Metal and Flexible" and performance requirements and design criteria indicated in "Duct Schedule" Article.
- B. Seismic Performance: Duct hangers and supports shall withstand the effects of earthquake motions determined according to SEI/ASCE 7 and with the requirements specified in Section 230548 "Vibration and Seismic Controls for HVAC."
  1. For equipment with a seismic importance factor of 1.0 the term "withstand" means "the unit will remain in place without separation of any parts from the device when subjected to the seismic forces specified."
  2. For equipment with a seismic importance factor of 1.5 the term "withstand" means "the unit will remain in place without separation of any parts from the device when subjected to the seismic forces specified and the unit will be fully operational after the seismic event."

- C. Structural Performance: Duct hangers and supports shall withstand the effects of gravity loads and stresses within limits and under conditions described in SMACNA's "HVAC Duct Construction Standards - Metal and Flexible"
- D. Airstream Surfaces: Surfaces in contact with the airstream shall comply with requirements in ASHRAE 62.1.

#### 1.4 ACTION SUBMITTALS

- A. Product Data: For each type of the following products:
  - 1. Liners and adhesives.
  - 2. Sealants and gaskets.
- B. Shop Drawings:
  - 1. Fabrication, assembly, and installation, including plans, elevations, sections, components, and attachments to other work.
  - 2. Factory- and shop-fabricated ducts and fittings.
  - 3. Duct layout indicating sizes, configuration, liner material, and static-pressure classes.
  - 4. Elevation of top of ducts.
  - 5. Dimensions of main duct runs from building grid lines.
  - 6. Fittings.
  - 7. Reinforcement and spacing.
  - 8. Seam and joint construction.
  - 9. Penetrations through fire-rated and other partitions.
  - 10. Equipment installation based on equipment being used on Project.
  - 11. Locations for duct accessories, including dampers, turning vanes, and access doors and panels.
  - 12. Hangers and supports, including methods for duct and building attachment and vibration isolation.
  - 13. Duct fabrication shall not begin until shop drawings have been submitted and reviewed by the mechanical engineer.
- C. Delegated-Design Submittal:
  - 1. Sheet metal thicknesses.
  - 2. Joint and seam construction and sealing.
  - 3. Reinforcement details and spacing.
  - 4. Materials, fabrication, assembly, and spacing of hangers and supports.
  - 5. Design Calculations: Calculations for selecting hangers and supports.

#### 1.5 INFORMATIONAL SUBMITTALS

- A. Coordination Drawings: Plans, drawn to scale, on which the following items are shown and coordinated with each other, using input from installers of the items involved:
  - 1. Duct installation in congested spaces, indicating coordination with general construction, building components, and other building services. Indicate proposed changes to duct layout.

2. Suspended ceiling components.
3. Structural members to which duct will be attached.
4. Size and location of initial access modules for acoustical tile.
5. Penetrations of smoke barriers and fire-rated construction.
6. Items penetrating finished ceiling including, but not limited to the following:
  - a. Lighting fixtures.
  - b. Air outlets and inlets.
  - c. Speakers.
  - d. Sprinklers.
  - e. Access panels.
  - f. Perimeter moldings.

- B. Field quality-control reports.

## 1.6 QUALITY ASSURANCE

- A. Welding Qualifications: Qualify procedures and personnel according to AWS D1.1/D1.1M, "Structural Welding Code - Steel," for hangers and supports. AWS D9.1M/D9.1, "Sheet Metal Welding Code," for duct joint and seam welding.
- B. Welding Qualifications: Qualify procedures and personnel according to the following:
1. AWS D1.1/D1.1M, "Structural Welding Code - Steel," for hangers and supports.
  2. AWS D1.2/D1.2M, "Structural Welding Code - Aluminum," for aluminum supports.
  3. AWS D9.1M/D9.1, "Sheet Metal Welding Code," for duct joint and seam welding.
- C. ASHRAE Compliance: Applicable requirements in ASHRAE 62.1, Section 5 - "Systems and Equipment" and Section 7 - "Construction and System Start-up."
- D. ASHRAE/IESNA Compliance: Applicable requirements in ASHRAE/IESNA 90.1, Section 6.4.4 - "HVAC System Construction and Insulation."

## PART 2 - PRODUCTS

### 2.1 SINGLE-WALL RECTANGULAR DUCTS AND FITTINGS

- A. General Fabrication Requirements: Comply with SMACNA's "HVAC Duct Construction Standards - Metal and Flexible" based on indicated static-pressure class unless otherwise indicated.
- B. Transverse Joints: Select joint types and fabricate according to SMACNA's "HVAC Duct Construction Standards - Metal and Flexible," Figure 2-1, "Rectangular Duct/Transverse Joints," for static-pressure class, applicable sealing requirements, materials involved, duct-support intervals, and other provisions in SMACNA's "HVAC Duct Construction Standards - Metal and Flexible."
- C. Longitudinal Seams: Select seam types and fabricate according to SMACNA's "HVAC Duct Construction Standards - Metal and Flexible," Figure 2-2, "Rectangular Duct/Longitudinal Seams," for static-pressure class, applicable sealing requirements,

materials involved, duct-support intervals, and other provisions in SMACNA's "HVAC Duct Construction Standards - Metal and Flexible."

- D. Duct dimensions shown on drawings are inside clear dimensions.
- E. Elbows, Transitions, Offsets, Branch Connections, and Other Duct Construction: Select types and fabricate according to SMACNA's "HVAC Duct Construction Standards - Metal and Flexible," Chapter 4, "Fittings and Other Construction," for static-pressure class, applicable sealing requirements, materials involved, duct-support intervals, and other provisions in SMACNA's "HVAC Duct Construction Standards - Metal and Flexible."

## 2.2 SINGLE-WALL ROUND AND FLAT-OVAL DUCTS AND FITTINGS

- A. General Fabrication Requirements: Comply with SMACNA's "HVAC Duct Construction Standards - Metal and Flexible," Chapter 3, "Round, Oval, and Flexible Duct," based on indicated static-pressure class unless otherwise indicated.
- B. Duct dimensions shown on drawings are inside clear dimensions.
- C. Flat-Oval Ducts: Indicated dimensions are the duct width (major dimension) and diameter of the round sides connecting the flat portions of the duct (minor dimension).
- D. Transverse Joints: Select joint types and fabricate according to SMACNA's "HVAC Duct Construction Standards - Metal and Flexible," Figure 3-1, "Round Duct Transverse Joints," for static-pressure class, applicable sealing requirements, materials involved, duct-support intervals, and other provisions in SMACNA's "HVAC Duct Construction Standards - Metal and Flexible."
  - 1. Transverse Joints in Ducts Larger Than 60 Inches in Diameter: Flanged.
- E. Longitudinal Seams: Not allowed.
- F. Tees and Laterals: Select types and fabricate according to SMACNA's "HVAC Duct Construction Standards - Metal and Flexible," Figure 3-5, "90 Degree Tees and Laterals," and Figure 3-6, "Conical Tees," for static-pressure class, applicable sealing requirements, materials involved, duct-support intervals, and other provisions in SMACNA's "HVAC Duct Construction Standards - Metal and Flexible."

## 2.3 SHEET METAL MATERIALS

- A. General Material Requirements: Comply with SMACNA's "HVAC Duct Construction Standards - Metal and Flexible" for acceptable materials, material thicknesses, and duct construction methods unless otherwise indicated. Sheet metal materials shall be free of pitting, seam marks, roller marks, stains, discolorations, and other imperfections.
- B. Galvanized Sheet Steel: Comply with ASTM A 653.
  - 1. Galvanized Coating Designation: G90.
  - 2. Finishes for Surfaces Exposed to View: Mill phosphatized.

- C. Reinforcement Shapes and Plates: ASTM A 36, steel plates, shapes, and bars; black and galvanized.
  - 1. Where black- and galvanized-steel shapes and plates are used to reinforce aluminum ducts, isolate the different metals with butyl rubber, neoprene, or EPDM gasket materials.
- D. Tie Rods: Galvanized steel, 1/4-inch minimum diameter for lengths 36 inches or less; 3/8-inch minimum diameter for lengths longer than 36 inches.

## 2.4 DUCT LINER

- A. Fibrous-Glass Duct Liner: Comply with ASTM C 1071, NFPA 90A, or NFPA 90B; and with NAIMA AH124, "Fibrous Glass Duct Liner Standard."
  - 1. Manufacturers: Subject to compliance with requirements, provide products by one of the following:
    - a. CertainTeed Corporation; Insulation Group.
    - b. Johns Manville.
    - c. Knauf Insulation.
    - d. Owens Corning.
  - 2. Maximum Thermal Conductivity:
    - a. Type I, Flexible: 0.27 Btu x in./h x sq. ft. x deg F at 75 deg F mean temperature.
    - b. Type II, Rigid: 0.23 Btu x in./h x sq. ft. x deg F at 75 deg F mean temperature.
  - 3. Antimicrobial Erosion-Resistant Coating: Apply to the surface of the liner that will form the interior surface of the duct to act as a moisture repellent and erosion-resistant coating. Antimicrobial compound shall be tested for efficacy by an NRTL and registered by the EPA for use in HVAC systems.
  - 4. Water-Based Liner Adhesive:
    - a. Comply with NFPA 90A or NFPA 90B and with ASTM C 916.
    - b. For indoor applications, adhesive shall have a VOC content of 80 g/L or less when calculated according to 40 CFR 59, Subpart D (EPA Method 24).
- B. Flexible Elastomeric Duct Liner: Preformed, cellular, closed-cell, sheet materials complying with ASTM C 534, Type II, Grade 1; and with NFPA 90A or NFPA 90B.
  - 1. Manufacturers: Subject to compliance with requirements, provide products by one of the following:
    - a. Aeroflex USA Inc.
    - b. Armacell LLC.
    - c. Rubatex International, LLC
  - 2. Surface-Burning Characteristics: Maximum flame-spread index of 25 and maximum smoke-developed index of 50 when tested according to UL 723; certified by an NRTL.

3. Liner Adhesive: As recommended by insulation manufacturer and complying with NFPA 90A or NFPA 90B.
  - a. For indoor applications, adhesive shall have a VOC content of 50 g/L or less when calculated according to 40 CFR 59, Subpart D (EPA Method 24).
- C. Insulation Pins and Washers:
  1. Cupped-Head, Capacitor-Discharge-Weld Pins: Copper- or zinc-coated steel pin, fully annealed for capacitor-discharge welding, , length to suit depth of insulation indicated with integral 1-1/2-inch galvanized carbon-steel washer.
    - a. 0.135-inch-diameter shank.
  2. Insulation-Retaining Washers: With beveled edge sized as required to hold insulation securely in place but not less than 1-1/2 inches in diameter.
    - a. Self-locking washers formed from 0.016-inch-thick aluminum.
- D. Shop Application of Duct Liner: Comply with SMACNA's "HVAC Duct Construction Standards - Metal and Flexible," Figure 7-11, "Flexible Duct Liner Installation."
  1. Adhere a single layer of indicated thickness of duct liner with at least 90 percent adhesive coverage at liner contact surface area. Attaining indicated thickness with multiple layers of duct liner is prohibited.
  2. Apply adhesive to transverse edges of liner facing upstream that do not receive metal nosing.
  3. Butt transverse joints without gaps, and coat joint with adhesive.
  4. Fold and compress liner in corners of rectangular ducts or cut and fit to ensure butted-edge overlapping.
  5. Do not apply liner in rectangular ducts with longitudinal joints, except at corners of ducts, unless duct size and dimensions of standard liner make longitudinal joints necessary.
  6. Secure liner with mechanical fasteners 4 inches from corners and at intervals not exceeding 12 inches transversely; at 3 inches from transverse joints and at intervals not exceeding 18 inches longitudinally.
  7. Secure transversely oriented liner edges facing the airstream with metal nosings that have either channel or "Z" profiles or are integrally formed from duct wall. Fabricate edge facings at the following locations:
    - a. Fan discharges.
    - b. Intervals of lined duct preceding unlined duct.
  8. Secure insulation between perforated sheet metal inner duct of same thickness as specified for outer shell. Use mechanical fasteners that maintain inner duct at uniform distance from outer shell without compressing insulation.
    - a. Sheet Metal Inner Duct Perforations: 3/32-inch diameter, with an overall open area of 23 percent.
  9. Terminate inner ducts with buildouts attached to fire-damper sleeves, dampers, turning vane assemblies, or other devices. Fabricated build-outs (metal hat sections) or other buildout means are optional; when used, secure buildouts to duct walls with bolts, screws, rivets, or welds.

## 2.5 SEALANT AND GASKETS

- A. General Sealant and Gasket Requirements: Surface-burning characteristics for sealants and gaskets shall be a maximum flame-spread index of 25 and a maximum smoke-developed index of 50 when tested according to UL 723; certified by an NRTL.
- B. Two-Part Tape Sealing System:
1. Tape: Woven cotton fiber impregnated with mineral gypsum and modified acrylic/silicone activator to react exothermically with tape to form hard, durable, airtight seal.
  2. Tape Width: 4 inches.
  3. Sealant: Modified styrene acrylic.
  4. Water resistant.
  5. Mold and mildew resistant.
  6. Maximum Static-Pressure Class: 10-inch wg, positive and negative.
  7. Service: Indoor and outdoor.
  8. Service Temperature: Minus 40 to plus 200 deg F.
  9. Substrate: Compatible with galvanized sheet steel (both PVC coated and bare), stainless steel, or aluminum.
  10. For indoor applications, sealant shall have a VOC content of 250 g/L or less when calculated according to 40 CFR 59, Subpart D (EPA Method 24).
- C. Water-Based Joint and Seam Sealant:
1. Application Method: Brush on.
  2. Solids Content: Minimum 65 percent.
  3. Shore A Hardness: Minimum 20.
  4. Water resistant.
  5. Mold and mildew resistant.
  6. VOC: Maximum 75 g/L (less water).
  7. Maximum Static-Pressure Class: 10-inch wg, positive and negative.
  8. Service: Indoor or outdoor.
  9. Substrate: Compatible with galvanized sheet steel, stainless steel, or aluminum sheets.
- D. Solvent-Based Joint and Seam Sealant:
1. Application Method: Brush on.
  2. Base: Synthetic rubber resin.
  3. Solvent: Toluene and heptane.
  4. Solids Content: Minimum 60 percent.
  5. Shore A Hardness: Minimum 60.
  6. Water resistant.
  7. Mold and mildew resistant.
  8. For indoor applications, sealant shall have a VOC content of 250 g/L or less when calculated according to 40 CFR 59, Subpart D (EPA Method 24).
  9. VOC: Maximum 395 g/L.
  10. Maximum Static-Pressure Class: 10-inch wg, positive or negative.
  11. Service: Indoor or outdoor.
  12. Substrate: Compatible with galvanized sheet steel (both PVC coated and bare), stainless steel, or aluminum sheets.

- E. Flanged Joint Sealant: Comply with ASTM C 920.
  - 1. General: Single-component, acid-curing, silicone, elastomeric.
  - 2. Type: S.
  - 3. Grade: NS.
  - 4. Class: 25.
  - 5. Use: O.
  - 6. For indoor applications, sealant shall have a VOC content of 250 g/L or less when calculated according to 40 CFR 59, Subpart D (EPA Method 24).
- F. Flange Gaskets: Butyl rubber, neoprene, or EPDM polymer with polyisobutylene plasticizer.
- G. Round Duct Joint O-Ring Seals:
  - 1. Seal shall provide maximum leakage class of 3 cfm/100 sq. ft. at 1-inch wg and shall be rated for 10-inch wg static-pressure class, positive or negative.
  - 2. EPDM O-ring to seal in concave bead in coupling or fitting spigot.
  - 3. Double-lipped, EPDM O-ring seal, mechanically fastened to factory-fabricated couplings and fitting spigots.

## 2.6 HANGERS AND SUPPORTS

- A. Hanger Rods for Noncorrosive Environments: Cadmium-plated steel rods and nuts.
- B. Hanger Rods for Corrosive Environments: Electrogalvanized, all-thread rods or galvanized rods with threads painted with zinc-chromate primer after installation.
- C. Strap and Rod Sizes: Comply with SMACNA's "HVAC Duct Construction Standards - Metal and Flexible," Table 5-1, "Rectangular Duct Hangers Minimum Size," and Table 5-2, "Minimum Hanger Sizes for Round Duct."
- D. Steel Cables for Galvanized-Steel Ducts: Galvanized steel complying with ASTM A 603.
- E. Steel Cables for Stainless-Steel Ducts: Stainless steel complying with ASTM A 492.
- F. Steel Cable End Connections: Cadmium-plated steel assemblies with brackets, swivel, and bolts designed for duct hanger service; with an automatic-locking and clamping device.
- G. Duct Attachments: Sheet metal screws, blind rivets, or self-tapping metal screws; compatible with duct materials.
- H. Trapeze and Riser Supports:
  - 1. Supports for Galvanized-Steel Ducts: Galvanized-steel shapes and plates.
  - 2. Supports for Stainless-Steel Ducts: Stainless-steel shapes and plates.
  - 3. Supports for Aluminum Ducts: Aluminum or galvanized steel coated with zinc chromate.



## PART 3 - EXECUTION

## 3.1 DUCT INSTALLATION

- A. Drawing plans, schematics, and diagrams indicate general location and arrangement of duct system. Indicated duct locations, configurations, and arrangements were used to size ducts and calculate friction loss for air-handling equipment sizing and for other design considerations. Install duct systems as indicated unless deviations to layout are approved on Shop Drawings and Coordination Drawings.
- B. Install ducts according to SMACNA's "HVAC Duct Construction Standards - Metal and Flexible" unless otherwise indicated.
- C. Install round and flat-oval ducts in maximum practical lengths.
- D. Install ducts with fewest possible joints.
- E. Install factory- or shop-fabricated fittings for changes in direction, size, and shape and for branch connections.
- F. Unless otherwise indicated, install ducts vertically and horizontally, and parallel and perpendicular to building lines.
- G. Install ducts close to walls, overhead construction, columns, and other structural and permanent enclosure elements of building.
- H. Install ducts with a clearance of 2 inch, plus allowance for insulation thickness.
- I. Route ducts to avoid passing through transformer vaults and electrical equipment rooms and enclosures.
- J. Where ducts pass through non-fire-rated interior partitions and exterior walls and are exposed to view, cover the opening between the partition and duct or duct insulation with sheet metal flanges of same metal thickness as the duct. Overlap openings on four sides by at least 1-1/2 inches.
- K. Where ducts pass through fire-rated interior partitions and exterior walls, install fire dampers. Comply with requirements in Section 233300 "Air Duct Accessories" for fire and smoke dampers.
- L. Protect duct interiors from moisture, construction debris and dust, and other foreign materials. Comply with SMACNA's "IAQ Guidelines for Occupied Buildings Under Construction," Appendix G, "Duct Cleanliness for New Construction Guidelines" .

## 3.2 INSTALLATION OF EXPOSED DUCTWORK

- A. Protect ducts exposed in finished spaces from being dented, scratched, or damaged.
- B. Trim duct sealants flush with metal. Create a smooth and uniform exposed bead. Do not use two-part tape sealing system.

- C. Grind welds to provide smooth surface free of burrs, sharp edges, and weld splatter. When welding stainless steel with a No. 3 or 4 finish, grind the welds flush, polish the exposed welds, and treat the welds to remove discoloration caused by welding.
- D. Maintain consistency, symmetry, and uniformity in the arrangement and fabrication of fittings, hangers and supports, duct accessories, and air outlets.
- E. Repair or replace damaged sections and finished work that does not comply with these requirements.

### 3.3 DUCT SEALING

- A. Seal ducts for duct static-pressure, seal classes, and leakage classes specified in "Duct Schedule" Article according to SMACNA's "HVAC Duct Construction Standards - Metal and Flexible."
- B. Seal ducts to the following seal classes according to SMACNA's "HVAC Duct Construction Standards - Metal and Flexible":
  - 1. Comply with SMACNA's "HVAC Duct Construction Standards - Metal and Flexible."
  - 2. Outdoor, Supply-Air Ducts: Seal Class A.
  - 3. Outdoor, Exhaust Ducts: Seal Class A.
  - 4. Outdoor, Return-Air Ducts: Seal Class A.
  - 5. Unconditioned Space, Supply-Air Ducts in Pressure Classes 2-Inch wg and Lower: Seal Class A.
  - 6. Unconditioned Space, Supply-Air Ducts in Pressure Classes Higher Than 2-Inch wg: Seal Class A.
  - 7. Unconditioned Space, Exhaust Ducts: Seal Class A.
  - 8. Unconditioned Space, Return-Air Ducts: Seal Class A.
  - 9. Conditioned Space, Supply-Air Ducts in Pressure Classes 2-Inch wg and Lower: Seal Class A.
  - 10. Conditioned Space, Supply-Air Ducts in Pressure Classes Higher Than 2-Inch wg: Seal Class A.
  - 11. Conditioned Space, Exhaust Ducts: Seal Class A.
  - 12. Conditioned Space, Return-Air Ducts: Seal Class A.

### 3.4 HANGER AND SUPPORT INSTALLATION

- A. Comply with SMACNA's "HVAC Duct Construction Standards - Metal and Flexible," Chapter 5, "Hangers and Supports."
- B. Building Attachments: Concrete inserts, powder-actuated fasteners, or structural-steel fasteners appropriate for construction materials to which hangers are being attached.
  - 1. Where practical, install concrete inserts before placing concrete.

2. Install powder-actuated concrete fasteners after concrete is placed and completely cured.
  3. Use powder-actuated concrete fasteners for standard-weight aggregate concretes or for slabs more than 4 inches thick.
  4. Do not use powder-actuated concrete fasteners for lightweight-aggregate concretes or for slabs less than 4 inches thick.
  5. Do not use powder-actuated concrete fasteners for seismic restraints.
- C. Hanger Spacing: Comply with SMACNA's "HVAC Duct Construction Standards - Metal and Flexible," Table 5-1, "Rectangular Duct Hangers Minimum Size," and Table 5-2, "Minimum Hanger Sizes for Round Duct," for maximum hanger spacing; install hangers and supports within 24 inches of each elbow and within 48 inches of each branch intersection.
- D. Hangers Exposed to View: Threaded rod and angle or channel supports.
- E. Support vertical ducts with steel angles or channel secured to the sides of the duct with welds, bolts, sheet metal screws, or blind rivets; support at each floor and at a maximum intervals of 16 feet.
- F. Install upper attachments to structures. Select and size upper attachments with pull-out, tension, and shear capacities appropriate for supported loads and building materials where used.

### 3.5 SEISMIC-RESTRAINT-DEVICE INSTALLATION

- A. Install ducts with hangers and braces designed to support the duct and to restrain against seismic forces required by applicable building codes. Comply with the requirements specified in Section 23 0548 "Vibration and Seismic Controls for HVAC."
1. Comply with ASCE/SEI 7.

### 3.6 CONNECTIONS

- A. Make connections to equipment with flexible connectors complying with Section 233300 "Air Duct Accessories."
- B. Comply with SMACNA's "HVAC Duct Construction Standards - Metal and Flexible" for branch, outlet and inlet, and terminal unit connections.

### 3.7 PAINTING

- A. Paint interior of metal ducts that are visible through registers and grilles and that do not have duct liner. Apply one coat of flat, black, latex paint over a compatible galvanized-steel primer. Paint materials and application requirements are specified in Section 099113 "Exterior Painting" and Section 099123 "Interior Painting."

### 3.8 FIELD QUALITY CONTROL

- A. Perform tests and inspections.

## B. Leakage Tests:

1. Comply with SMACNA's "HVAC Air Duct Leakage Test Manual." Submit a test report for each test.
2. Test the following systems:
  - a. Supply Ducts with a Pressure Class of 2-Inch wg or Higher: Test representative duct sections, selected by Architect from sections installed, totaling no less than 50 percent of total installed duct area for each designated pressure class.
  - b. Return Ducts with a Pressure Class of 2-Inch wg or Higher: Test representative duct sections, selected by Architect from sections installed, totaling no less than 50 percent of total installed duct area for each designated pressure class.
  - c. Exhaust Ducts with a Pressure Class of 2-Inch wg or Higher: Test representative duct sections, selected by Architect from sections installed, totaling no less than 50 percent of total installed duct area for each designated pressure class.
  - d. Outdoor Air Ducts with a Pressure Class of 2-Inch wg or Higher: Test representative duct sections, selected by Architect from sections installed, totaling no less than 50 percent of total installed duct area for each designated pressure class.
3. Disassemble, reassemble, and seal segments of systems to accommodate leakage testing and for compliance with test requirements.
4. Test for leaks before applying external insulation.
5. Conduct tests at static pressures equal to maximum design pressure of system or section being tested. If static-pressure classes are not indicated, test system at maximum system design pressure. Do not pressurize systems above maximum design operating pressure.
6. Give seven days' advance notice for testing.

## C. Duct System Cleanliness Tests:

1. Visually inspect duct system to ensure that no visible contaminants are present.
2. Any liner showing evidence that it has wet at any time shall be removed and replaced with new liner.
  - a. Disinfect affected sheet metal, and pins.
  - b. Install new liner per specifications
  - c. Seal friable edges and seams of repaired liner.

D. Duct system will be considered defective if it does not pass tests and inspections.

E. Prepare test and inspection reports.

## 3.9 DUCT CLEANING

- A. Clean new duct system before testing, adjusting, and balancing.
- B. Use service openings for entry and inspection.

1. Create new openings and install access panels appropriate for duct static-pressure class if required for cleaning access. Provide insulated panels for insulated or lined duct. Patch insulation and liner as recommended by duct liner manufacturer. Comply with Section 233300 "Air Duct Accessories" for access panels and doors.
  2. Disconnect and reconnect flexible ducts as needed for cleaning and inspection.
  3. Remove and reinstall ceiling to gain access during the cleaning process.
- C. Particulate Collection and Odor Control:
1. When venting vacuuming system inside the building, use HEPA filtration with 99.97 percent collection efficiency for 0.3-micron-size (or larger) particles.
  2. When venting vacuuming system to outdoors, use filter to collect debris removed from HVAC system, and locate exhaust downwind and away from air intakes and other points of entry into building.
- D. Clean the following components by removing surface contaminants and deposits:
1. Air outlets and inlets (registers, grilles, and diffusers).
  2. Supply, return, and exhaust fans including fan housings, plenums (except ceiling supply and return plenums), scrolls, blades or vanes, shafts, baffles, dampers, and drive assemblies.
  3. Air-handling unit internal surfaces and components including mixing box, coil section, air wash systems, spray eliminators, condensate drain pans, humidifiers and dehumidifiers, filters and filter sections, and condensate collectors and drains.
  4. Coils and related components.
  5. Return-air ducts, dampers, actuators, and turning vanes except in ceiling plenums and mechanical equipment rooms.
  6. Supply-air ducts, dampers, actuators, and turning vanes.
  7. Dedicated exhaust and ventilation components and makeup air systems.
- E. Mechanical Cleaning Methodology:
1. Clean metal duct systems using mechanical cleaning methods that extract contaminants from within duct systems and remove contaminants from building.
  2. Use vacuum-collection devices that are operated continuously during cleaning. Connect vacuum device to downstream end of duct sections so areas being cleaned are under negative pressure.
  3. Use mechanical agitation to dislodge debris adhered to interior duct surfaces without damaging integrity of metal ducts, duct liner, or duct accessories.
  4. Clean fibrous-glass duct liner with HEPA vacuuming equipment; do not permit duct liner to get wet. Replace fibrous-glass duct liner that is damaged, deteriorated, or delaminated or that has friable material, mold, or fungus growth.
  5. Clean coils and coil drain pans according to NADCA 1992. Keep drain pan operational. Rinse coils with clean water to remove latent residues and cleaning materials; comb and straighten fins.
  6. Provide drainage and cleanup for wash-down procedures.

7. Antimicrobial Agents and Coatings: Apply EPA-registered antimicrobial agents if fungus is present. Apply antimicrobial agents according to manufacturer's written instructions after removal of surface deposits and debris.

### 3.10 START UP

- A. Air Balance: Comply with requirements in Section 230593 "Testing, Adjusting, and Balancing for HVAC."

### 3.11 DUCT SCHEDULE

- A. Fabricate ducts with galvanized sheet steel.
- B. Ductwork running in areas where there are no ceilings or when noted on the drawings shall be doubled wall duct and shall meet the requirements indicated below.
- C. Supply Ducts:
  1. Ducts Connected to Fan Coil Units, Furnaces, Heat Pumps, and Terminal Units:
    - a. Pressure Class: Positive 2-inch wg.
    - b. Minimum SMACNA Seal Class: A.
    - c. SMACNA Leakage Class for Rectangular: 16.
    - d. SMACNA Leakage Class for Round: 8.
  2. Ducts Connected to Constant-Volume Air-Handling Units:
    - a. Pressure Class: Positive 3-inch wg.
    - b. Minimum SMACNA Seal Class: A.
    - c. SMACNA Leakage Class for Rectangular: 8.
    - d. SMACNA Leakage Class for Round: 4.
  3. Ducts Connected to Variable-Air-Volume Air-Handling Units:
    - a. Pressure Class: Positive 6-inch wg.
    - b. Minimum SMACNA Seal Class: A.
    - c. SMACNA Leakage Class for Rectangular: 4.
    - d. SMACNA Leakage Class for Round: 2.
  4. Ducts Connected to Equipment Not Listed Above:
    - a. Pressure Class: Positive 4-inch wg.
    - b. Minimum SMACNA Seal Class: A.
    - c. SMACNA Leakage Class for Rectangular: 4.
    - d. SMACNA Leakage Class for Round: 2.

## D. Return Ducts:

1. Ducts Connected to Fan Coil Units, Furnaces, Heat Pumps, and Terminal Units:
  - a. Pressure Class: Positive or negative 2-inch wg.
  - b. Minimum SMACNA Seal Class: A.
  - c. SMACNA Leakage Class for Rectangular: 16.
  - d. SMACNA Leakage Class for Round: 8.
2. Ducts Connected to Air-Handling Units:
  - a. Pressure Class: Positive or negative 2-inch wg.
  - b. Minimum SMACNA Seal Class: A.
  - c. SMACNA Leakage Class for Rectangular: 16.
  - d. SMACNA Leakage Class for Round: 8
3. Ducts Connected to Equipment Not Listed Above:
  - a. Pressure Class: Positive or negative 3-inch wg.
  - b. Minimum SMACNA Seal Class: A.
  - c. SMACNA Leakage Class for Rectangular: 8.
  - d. SMACNA Leakage Class for Round: 4.

## E. Exhaust Ducts:

1. Ducts Connected to Fans Exhausting (ASHRAE 62.1, Class 1 and 2) Air:
  - a. Pressure Class: Negative 2-inch wg.
  - b. Minimum SMACNA Seal Class: A.
  - c. SMACNA Leakage Class for Rectangular: 16.
  - d. SMACNA Leakage Class for Round: 4.
2. Ducts Connected to Air-Handling Units:
  - a. Pressure Class: Positive or negative 3-inch wg.
  - b. Minimum SMACNA Seal Class: A.
  - c. SMACNA Leakage Class for Rectangular: 8.
  - d. SMACNA Leakage Class for Round: 4.
3. Ducts Connected to Variable-Air-Volume Air-Handling Units:
  - a. Pressure Class: Positive 6-inch wg.
  - b. Minimum SMACNA Seal Class: A.

- c. SMACNA Leakage Class for Rectangular: 4.
    - d. SMACNA Leakage Class for Round: 2.
  - 4. Ducts Connected to Equipment Not Listed Above:
    - a. Pressure Class: Positive or negative 4-inch wg.
    - b. Minimum SMACNA Seal Class: A.
    - c. SMACNA Leakage Class for Rectangular: 4 .
    - d. SMACNA Leakage Class for Round: 2 .
- F. Outdoor-Air (Not Filtered, Heated, or Cooled) Ducts:
  - 1. Ducts Connected to Fan Coil Units, Furnaces, Heat Pumps, and Terminal Units:
    - a. Pressure Class: Positive or negative 2-inch wg.
    - b. Minimum SMACNA Seal Class: A.
    - c. SMACNA Leakage Class for Rectangular: 16 .
    - d. SMACNA Leakage Class for Round and Flat Oval: 4.
  - 2. Ducts Connected to Air-Handling Units:
    - a. Pressure Class: Positive or negative 3-inch wg.
    - b. Minimum SMACNA Seal Class: A.
    - c. SMACNA Leakage Class for Rectangular: 8.
    - d. SMACNA Leakage Class for Round: 4.
  - 3. Ducts Connected to Equipment Not Listed Above:
    - a. Pressure Class: Positive or negative 3-inch wg.
    - b. Minimum SMACNA Seal Class: A.
    - c. SMACNA Leakage Class for Rectangular: 8.
    - d. SMACNA Leakage Class for Round: 4.
- G. Intermediate Reinforcement:
  - 1. Galvanized-Steel Ducts: Galvanized steel.
- H. Duct Liner Restrictions:
  - 1. Duct liner exposed to air movement shall not be used in supply air ducts serving the following rooms: Operating rooms, trauma rooms, LDR rooms, NICU nurseries, ICU nurseries, positive pressure isolation rooms, cath labs, bone marrow, triage rooms, angiogram rooms, fluoroscopy rooms, linear accelerators,



decontamination areas and any invasive procedure rooms where the duct insulation could be a source of contamination.

2. Duct Liner exposed to air movement shall not be used on medium pressure ductwork (2000 to 4000 FPM velocity). See section 230713 "Duct Insulation" for insulation requirements.
  3. Duct Liner exposed to air movement shall not be used on high pressure ductwork (Greater than 4000 FPM velocity). See section 230713 "Duct Insulation" for insulation requirements.
  4. All duct liner shall meet all of the requirements found in 2012 IECC
- I. Liner: (Ductwork located in Unconditioned space)
1. Low Pressure Supply Air Ducts (Less than 2000 FPM velocity): Fibrous glass, Type I, 1-1/2 inch thick with a minimum R value of 6.0 for ducts in unconditioned spaces.
  2. Supply Air Ducts: Fibrous glass, Type I [or flexible elastomeric] [Natural fiber], 1 inch thick for ducts in conditioned spaces.
  3. Return Air Ducts: Fibrous glass, Type I, 1-1/2 inch thick with a minimum R value of 6.0 for ducts in unconditioned spaces.
  4. Return Air Ducts: Fibrous glass, Type I [or flexible elastomeric] [Natural fiber], 1 inch thick for ducts in conditioned spaces.
  5. Exhaust Air Ducts: Fibrous glass, Type I [or flexible elastomeric] [Natural fiber], 1 inch thick.
  6. Supply Fan Plenums: Fibrous glass, Type I, 1-1/2 inch thick with a minimum R value of 6.0.
  7. Return- and Exhaust-Fan Plenums: Fibrous glass, Type II, 1-1/2 inch thick with a minimum R value of 6.0.
  8. Transfer Ducts: Fibrous glass, Type I thick.
- J. Liner: (Ductwork located Interior to building Insulated Envelope)
1. Low Pressure Supply Air Ducts (Less than 2000 FPM velocity): Fibrous glass, Type I, 1 inch thick with a minimum R value of 4.0 for ducts in unconditioned spaces.
  2. Supply Air Ducts: Fibrous glass, Type I , 1 inch thick for ducts in conditioned spaces.
  3. Return Air Ducts: Fibrous glass, Type I, 1 inch thick with a minimum R value of 4.0 for ducts in unconditioned spaces.
  4. Return Air Ducts: Fibrous glass, Type I , 1 inch thick for ducts in conditioned spaces.

5. Exhaust Air Ducts: Fibrous glass, Type I, 1 inch thick.
  6. Supply Fan Plenums: Fibrous glass, Type I, 1 inch thick with a minimum R value of 4.0.
  7. Return- and Exhaust-Fan Plenums: Fibrous glass, Type II, 1 inch thick with a minimum R value of 4.0.
  8. Transfer Ducts: Fibrous glass, Type I, 1 inch thick.
- K. Elbow Configuration:
1. Rectangular Duct: Comply with SMACNA's "HVAC Duct Construction Standards - Metal and Flexible," Figure 4-2, "Rectangular Elbows."
    - a. Radius Type RE 1 with minimum 1.5 radius-to-diameter ratio.
    - b. Radius Type RE 3 with minimum 1.0 radius-to-diameter ratio and two vanes.
    - c. Mitered Type RE 2 with vanes complying with SMACNA's "HVAC Duct Construction Standards - Metal and Flexible," Figure 4-3, "Vanes and Vane Runners," and Figure 4-4, "Vane Support in Elbows."
  2. Round Duct: Comply with SMACNA's "HVAC Duct Construction Standards - Metal and Flexible," Figure 3-4, "Round Duct Elbows."
    - a. Minimum Radius-to-Diameter Ratio and Elbow Segments: Comply with SMACNA's "HVAC Duct Construction Standards - Metal and Flexible," Table 3-1, "Mitered Elbows." Elbows with less than 90-degree change of direction have proportionately fewer segments.
      - 1) Velocity 1000 fpm or Lower: 1.0 radius-to-diameter ratio and three segments for 90-degree elbow.
      - 2) Velocity 1000 to 1500 fpm: 1.5 radius-to-diameter ratio and four segments for 90-degree elbow.
      - 3) Velocity 1500 fpm or Higher: 1.5 radius-to-diameter ratio and five segments for 90-degree elbow.
      - 4) Radius-to Diameter Ratio: 1.5.
    - b. Round Elbows, 12 Inches and Smaller in Diameter: Stamped or pleated.
    - c. Round Elbows, 14 Inches and Larger in Diameter: Welded.
- L. Branch Configuration:
1. Rectangular Duct: Comply with SMACNA's "HVAC Duct Construction Standards - Metal and Flexible," Figure 4-6, "Branch Connection."
    - a. Rectangular Main to Rectangular Branch: 45-degree entry high efficiency take-off.
    - b. Rectangular Main to Round Branch: 45-degree entry high efficiency take-off.
  2. Round and Flat Oval:

- a. Comply with SMACNA's "HVAC Duct Construction Standards - Metal and Flexible," Figure 3-5, "90 Degree Tees and Laterals," and Figure 3-6, "Conical Tees." Saddle taps are permitted in existing duct.
- b. Velocity 1000 to 1500 fpm: 45-degree entry high efficiency tap.
- c. Velocity 1500 fpm or Higher: 45-degree lateral.

END OF SECTION

**SECTION 23 33 00 - AIR DUCT ACCESSORIES**

## PART 1 - GENERAL

## 1.1 RELATED DOCUMENTS

- A. Drawings and general provisions of the Contract, including General and Supplementary Conditions and Division 01 Specification Sections, apply to this Section.

## 1.2 SUMMARY

## A. Section Includes:

1. Backdraft dampers
2. Manual volume dampers.
3. Control dampers
4. Fire dampers.
5. Smoke dampers.
6. Combination fire and smoke dampers.
7. Turning vanes.
8. Remote damper operators.
9. Duct-mounted access doors.
10. Flexible connectors.
11. Flexible ducts.
12. Duct accessory hardware.
13. High efficiency take-offs.

## B. Related Requirements:

1. Division 23 "HVAC Gravity Ventilators" for roof-mounted ventilator caps.
2. Division 23 "Diffusers, Registers and Grilles".
3. Division 28 "Digital, Addressable Fire-Alarm System" for duct-mounted fire and smoke detectors.
4. Division 28 "Zoned (DC-Loop) Fire-Alarm System" for duct-mounted fire and smoke detectors.

## 1.3 ACTION SUBMITTALS

## A. Product Data: For each type of product.

1. For duct silencers, include pressure drop and dynamic insertion loss data. Include breakout noise calculations for high transmission loss casings.

## B. Shop Drawings: For duct accessories. Include plans, elevations, sections, details and attachments to other work.

1. Detail duct accessories fabrication and installation in ducts and other construction. Include dimensions, weights, loads, and required clearances; and

method of field assembly into duct systems and other construction. Include the following:

- a. Special fittings.
- b. Manual volume damper installations.
- c. Control-damper installations.
- d. Fire-damper, smoke-damper, combination fire- and smoke-damper, pressure relief-damper, ceiling, and corridor damper installations, including sleeves; and duct-mounted access doors and remote damper operators.
- e. Wiring Diagrams: For power, signal, and control wiring.

#### 1.4 INFORMATIONAL SUBMITTALS

- A. Coordination Drawings: Reflected ceiling plans, drawn to scale, on which ceiling-mounted access panels and access doors required for access to duct accessories are shown and coordinated with each other, using input from Installers of the items involved.
- B. Source quality-control reports.

#### 1.5 CLOSEOUT SUBMITTALS

- A. Operation and Maintenance Data: For air duct accessories to include in operation and maintenance manuals.

#### 1.6 MAINTENANCE MATERIAL SUBMITTALS

- A. Furnish extra materials that match products installed and that are packaged with protective covering for storage and identified with labels describing contents.
  1. Fusible Links: Furnish quantity equal to 10 percent of amount installed.

### PART 2 - PRODUCTS

#### 2.1 ASSEMBLY DESCRIPTION

- A. Comply with NFPA 90A, "Installation of Air Conditioning and Ventilating Systems," and with NFPA 90B, "Installation of Warm Air Heating and Air Conditioning Systems."
- B. Comply with SMACNA's "HVAC Duct Construction Standards - Metal and Flexible" for acceptable materials, material thicknesses, and duct construction methods unless otherwise indicated. Sheet metal materials shall be free of pitting, seam marks, roller marks, stains, discolorations, and other imperfections.

#### 2.2 MATERIALS

- A. Galvanized Sheet Steel: Comply with ASTM A 653.

1. Galvanized Coating Designation: G60.
  2. Exposed-Surface Finish: Mill phosphatized.
- B. Aluminum Sheets: Comply with ASTM B 209, Alloy 3003, Temper H14; with mill finish for concealed ducts and standard, 1-side bright finish for exposed ducts.
- C. Extruded Aluminum: Comply with ASTM B 221, Alloy 6063, Temper T6.
- D. Reinforcement Shapes and Plates: Galvanized-steel reinforcement where installed on galvanized sheet metal ducts; compatible materials for aluminum and stainless-steel ducts.
- E. Tie Rods: Galvanized steel, 1/4-inch minimum diameter for lengths 36 inches or less; 3/8-inch minimum diameter for lengths longer than 36 inches.

### 2.3 BACKDRAFT DAMPERS

- A. Manufacturers: Subject to compliance with requirements, provide products by one of the following:
1. American Warming and Ventilating; a division of Mestek, Inc.
  2. Greenheck Fan Corporation.
  3. Nailor Industries Inc.
  4. Pottorff.
  5. Ruskin Company.
  6. United Enertech
- B. Function:
1. Designed to allow airflow in one direction and prevent reverse airflow.
  2. Keeps outside air out of the space by sensing and closing against mass flow.
- C. Description:
1. Gravity balanced.
- D. Maximum Air Velocity:
1. 1000 fpm
- E. Maximum System Pressure:
1. 3-inch wg.
- F. Frame: Hat-shaped, with welded corners or mechanically attached and mounting flange:
1. 16GA 0.063-inch- thick extruded aluminum.
- G. Blades: Multiple single-piece blades, maximum 6-inch width noncombustible, tear-resistant, neoprene-coated fiberglass with sealed edges:
1. Center pivoted: 16GA 0.050-inch- thick aluminum sheet.
- H. Blade Action: Parallel.
- I. Blade Seals: Mechanically locked.
1. Neoprene.

- J. Blade Axles: 0.20 inch diameter:
  - 1. Material: Nonferrous metal.
- K. Tie Bars and Brackets:
  - 1. Aluminum.
- L. Return Spring: Adjustable tension.
- M. Bearings:
  - 1. Synthetic pivot bushings.
- N. Accessories.
  - 1. Adjustment device to permit setting for varying differential static pressure.
  - 2. Counterweights and spring-assist kits for vertical airflow installations.
  - 3. Screen Mounting: Front mounted in sleeve.
    - a. Sleeve Thickness: 20 gage minimum.
    - b. Sleeve Length: 6 inches minimum.
  - 4. Screen Mounting: Rear mounted.
  - 5. Screen Material:
    - a. Aluminum.
  - 6. Screen Type:
    - a. Bird
  - 7. 90-degree stops.

## 2.4 MANUAL VOLUME DAMPERS

- A. Standard, Steel, Manual Volume Dampers:
  - 1. Manufacturers: Subject to compliance with requirements, provide products by one of the following:
    - a. American Warming and Ventilating; a division of Mestek, Inc.
    - b. McGill AirFlow LLC.
    - c. Nailor Industries Inc.
    - d. Pottorff.
    - e. Ruskin Company.
    - f. United Enertech
  - 2. Standard leakage rating , with linkage outside airstream .
  - 3. Suitable for horizontal or vertical applications.
  - 4. Frames: Hat-shaped, Mitered and welded corners. Flanges for attaching to walls and flangeless frames for installing in ducts.
    - a. 16GA 0.064-inch thick, galvanized sheet steel.
  - 5. Blades:
    - a. Multiple or single blade. Parallel- or opposed-blade design. Stiffened damper blades for stability.
    - b. Material:

- 1) Galvanized -steel, 16GA 0.064 inch thick.
6. Blade Axles:
    - a. Nonferrous metal
    - b. Shall extend full length of damper blades in ducts with pressure classes of 3-inch wg or more.
  7. Bearings:
    - a. Material:
      - 1) Molded synthetic.
    - b. Bearings at both ends of damper operating shafts in ducts with pressure classes of 3-inch wg or more.
  8. Tie Bars and Brackets: Galvanized steel.
- B. Low-Leakage, Steel, Manual Volume Dampers:
1. Manufacturers: Subject to compliance with requirements, provide products by one of the following:
    - a. American Warming and Ventilating; a division of Mestek, Inc.
    - b. McGill AirFlow LLC.
    - c. Nailor Industries Inc.
    - d. Pottorff.
    - e. Ruskin Company.
    - f. United Enertech
  2. Comply with AMCA 500-D testing for damper rating.
  3. Low-leakage rating , with linkage outside airstream, and bearing AMCA's Certified Ratings Seal for both air performance and air leakage.
  4. Suitable for horizontal or vertical applications.
  5. Frames:
    - a. Frame: Hat-shaped,
      - 1) 16GA 0.064-inch thick, galvanized sheet steel.
    - b. Mitered and welded corners.
    - c. Flanges for attaching to walls and flangeless frames for installing in ducts.
  6. Blades:
    - a. Multiple or single blade.
    - b. Parallel- or opposed-blade design.
    - c. Stiffen damper blades for stability.
    - d. Material:
      - 1) Galvanized, roll-formed steel, 16GA 0.064 inch thick.
  7. Blade Axles:
    - a. Nonferrous metal.
  8. Bearings:
    - a. Molded synthetic.
    - b. Dampers in ducts with pressure classes of 3-inch wg or more shall have axles full length of damper blades and bearings at both ends of operating shaft.



9. Blade Seals:
  - a. Neoprene.
10. Jamb Seals: Cambered Stainless steel or aluminum.
11. Tie Bars and Brackets: Galvanized steel or aluminum.
12. Accessories:
  - a. Include locking device to hold single-blade dampers in a fixed position without vibration.

C. Jackshaft:

1. Size:
  - a. 1-inch diameter.
2. Material: Galvanized-steel pipe rotating within pipe-bearing assembly mounted on supports at each mullion and at each end of multiple-damper assemblies.
3. Length and Number of Mountings: As required to connect linkage of each damper in multiple-damper assembly.

D. Damper Hardware:

1. Zinc-plated, die-cast core with dial and handle made of 3/32-inch- thick zinc-plated steel, and a 3/4-inch hexagon locking nut.
2. Include center hole to suit damper operating-rod size.
3. Include elevated platform for insulated duct mounting.

## 2.5 CONTROL DAMPERS

A. Manufacturers: Subject to compliance with requirements, provide products by one of the following:

1. Greenheck Fan Corporation.
2. Pottorff.
3. Ruskin Company.
4. Young Regulator Company.
5. United Enertech

B. Low-leakage rating, with linkage outside airstream, and bearing AMCA's Certified Ratings Seal for both air performance and air leakage.

C. Frames:

1. Section:
  - a. Hat shaped.
2. Material:
  - a. 20 GA 0.40-inch- thick galvanized steel.
3. Corners:
  - a. Mitered-and-welded.

D. Blades: Multiple.

1. Maximum blade width:
  - a. 6 inches.

2. Opposed -blade design.
3. Material:
  - a. Galvanized-steel.
4. Thickness:
  - a. 20 GA 0.40-inch- thick galvanized steel
5. Blade Edging: Inflatable seal blade edging, or replaceable rubber seals.
  - a. Closed-cell neoprene

E. Blade Axles:

1. Section:
  - a. 3/8-inch-square
2. Material:
  - a. Galvanized steel.
3. Blade-linkage hardware:
  - a. Zinc-plated steel and brass.
  - b. Ends sealed against blade bearings:
4. Operating Temperature Range: From minus 40 to plus 200 deg F.

F. Bearings:

1. Type:
  - a. Molded synthetic.
2. Axles: Dampers in ducts with pressure classes of 3-inch wg or more shall have axles full length of damper blades.
3. Bearings: Thrust bearings at each end of every blade. Bearings at both ends of each operating shaft.

## 2.6 FIRE DAMPERS

A. Manufacturers: Subject to compliance with requirements, provide products by one of the following:

1. Arrow United Industries; a division of Mestek, Inc.
2. Greenheck Fan Corporation.
3. Nailor Industries Inc.
4. Pottorff.
5. Ruskin Company.
6. United Enertech

B. Type:

1. Dynamic.

C. Standard: Rated and labeled according to UL 555 by an NRTL.

D. Closing rating in ducts up to 4-inch wg static pressure class and minimum 2000-fpm velocity.

E. Fire Rating:

1. 1-1/2 hours.

F. Frame:

1. Curtain type with blades outside airstream.
  2. Material:
    - a. Fabricated with roll-formed galvanized steel; with mitered and interlocking corners.
    - b. Thickness:
      - 1) 20GA-0.040-inch-.
- G. Mounting Sleeve: Factory- or field-installed, galvanized sheet steel. Length to suit application.
1. Minimum Thickness:
    - a. 18GA-0.05 inch, as indicated.
  2. Exception: Omit sleeve where damper-frame width permits direct attachment of perimeter mounting angles on each side of wall or floor; thickness of damper frame must comply with sleeve requirements.
- H. Mounting Orientation: Vertical or horizontal as indicated.
- I. Blades: Roll-formed, interlocking, galvanized sheet steel.
1. Thickness:
    - a. 24GA-0.024-inch-
  2. In place of interlocking blades, use full-length, 0.034-inch- thick, galvanized-steel blade connectors.
- J. Horizontal Dampers: Include blade lock and Type 301 constant force stainless-steel closure spring.
- K. Heat-Responsive Device: Replaceable, 212 deg F rated, fusible links.
- 2.7 SMOKE DAMPERS
- A. Manufacturers: Subject to compliance with requirements, provide products by one of the following:
1. Greenheck Fan Corporation.
  2. Nailor Industries Inc.
  3. Pottorff.
  4. Ruskin Company.
  5. United Enertech
- B. General Requirements: Label according to UL 555S by an NRTL.
- C. Smoke Detector: Integral, factory wired for single-point connection.
1. Type: Photoelectric.
- D. Frame: Galvanized sheet steel. With or without mounting flange as required.
1. Thickness:
    - a. Hat-shaped, 16GA-0.064-inch.
  2. Corners:
    - a. Welded.

- E. Blades: Horizontal, galvanized sheet steel.
  - 1. Section;
    - a. Roll-formed.
  - 2. Fit:
    - a. Interlocking.
  - 3. Thickness:
    - a. 14GA-0.079-inch.
- F. Leakage:
  - 1. Class II.
- G. Seals:
  - 1. Blade: Inflatable silicone fiberglass material to maintain smoke leakage rating to a minimum of 450 deg F.
- H. Rated pressure and velocity to exceed design airflow conditions.
- I. Mounting Sleeve: Factory-installed, galvanized sheet steel; length to suit wall or floor application with factory-furnished silicone caulking.
  - 1. Minimum 17-inches long.
  - 2. Thickness:
    - a. 0.05-inch-.
- J. Damper Motors:
  - 1. Action:
    - a. Two-position
  - 2. Mode: Fail close.
  - 3. Mounting: External.
- K. Comply with NEMA designation, temperature rating, service factor, enclosure type, and efficiency requirements for motors specified in Section 230513 "Common Motor Requirements for HVAC Equipment."
  - 1. Electrical Connection: 115 V, single phase, 60 Hz .
- L. Accessories:
  - 1. Auxiliary switches for signaling:
    - a. Position indication.
  - 2. Test Switch type:
    - a. Momentary test switch.
  - 3. Test Switch Mounting:
    - a. Damper.

## 2.8 COMBINATION FIRE AND SMOKE DAMPERS

- A. Manufacturers: Subject to compliance with requirements, provide products by one of the following:
  - 1. Greenheck Fan Corporation.
  - 2. Nailor Industries Inc.
  - 3. Pottorff.
  - 4. Ruskin Company.

5. United Enertech
  - B. Type: Dynamic; rated and labeled according to UL 555 and UL 555S by an NRTL.
  - C. Closing rating in ducts up to 4-inch wg static pressure class and minimum velocity of:
    1. 4000-fpm
  - D. Fire Rating:
    1. 1-1/2 hours.
  - E. Frame: Hat shaped, galvanized sheet steel. With or without mounting flange as required.
    1. Thickness:
      - a. 16GA-0.064-inch
    2. Corners:
      - a. Welded.
  - F. Heat-Responsive Device: Replaceable, 212 deg F rated, fusible links.
  - G. Blades: Horizontal, galvanized sheet steel.
    1. Type:
      - a. Air-foil.
    2. Fit:
      - a. Interlocking.
    3. Thickness:
      - a. 0.063-inch-.
  - H. Leakage:
    1. Class I.
  - I. Rated pressure and velocity to exceed design airflow conditions.
  - J. Mounting Sleeve: Factory-installed, galvanized sheet steel; length to suit wall or floor application with factory-furnished silicone calking.
    1. Thickness:
      - a. 18GA 0.05-inch-.
  - K. Master control panel for use in dynamic smoke-management systems.
  - L. Damper Motors:
    1. Locate outside air stream unless otherwise indicated,
    2. Action:
      - a. Two-position.
    3. Voltage: to match fire alarm system (coordinate).
    4. Listed: UL, as part of damper assembly.
    5. Outdoor Motors and Motors in Outside-Air Intakes:
      - a. Gaskets: O-ring gaskets designed to make motors weatherproof.
      - b. Internal heaters: Equip to permit normal operation at minus 40 deg F .
  - M. Comply with NEMA designation, temperature rating, service factor, enclosure type, and efficiency requirements for motors specified in Section 230513 "Common Motor Requirements for HVAC Equipment."
    1. Electrical Connection: 115 V, single phase, 60 Hz.

- N. Accessories:
  - 1. Auxiliary switches:
    - a. Signaling.
    - b. Position indication.
  - 2. Test Switch type:
    - a. Momentary test switch.
  - 3. Test Switch Mounting:
    - a. Damper.

## 2.9 TURNING VANES

- A. Manufacturers: Subject to compliance with requirements, provide products by one of the following:
  - 1. METALAIRE, Inc.
  - 2. SEMCO Incorporated.
  - 3. Ward Industries, Inc.; a division of Hart & Cooley, Inc.
- B. Manufactured Turning Vanes for Metal Ducts: Curved blades of galvanized sheet steel; support with bars perpendicular to blades set; set into vane runners suitable for duct mounting.
  - 1. Fabricate single blade vanes to comply with SMACNA's "HVAC Duct Construction Standards-Metal and Flexible."
  - 2. Acoustic Turning Vanes: Fabricate airfoil-shaped aluminum extrusions with perforated faces and fibrous-glass fill.
- C. Manufactured Turning Vanes for Nonmetal Ducts: Fabricate curved blades of resin-bonded fiberglass with acrylic polymer coating; support with bars perpendicular to blades set; set into vane runners suitable for duct mounting.
- D. General Requirements: Comply with SMACNA's "HVAC Duct Construction Standards - Metal and Flexible"; Figures 4-3, "Vanes and Vane Runners," and 4-4, "Vane Support in Elbows."
- E. Vane Construction:
  - 1. Single wall
- F. Vane Spacing:
  - 1. 1-1/2" spacing between turning vanes
  - 2. 3-1/4" spacing not allowed.
- G. Vane Construction: Single wall for ducts up to 36 inches wide and additional bracing for larger dimensions.

## 2.10 REMOTE DAMPER OPERATORS

- A. Manufacturers: Subject to compliance with requirements, provide products by one of the following:

1. Pottorff.
2. Ruskin Company; Tomkins PLC.
3. Young Regulator Company.

B. Cable Type:

1. Description: Cable system designed for remote manual damper adjustment.
2. Tubing/Sheathing: Galvanized, Brass, Copper or Aluminum.
3. Cable: Stainless steel or Steel.
4. Wall-Box Mounting: Coordinate with Architect.
5. Wall-Box Cover-Plate Material: Coordinate with Architect.

C. Activated Electric Type:

1. Description: Electrically activated zone control damper for remote adjustment. When an adjustment is needed the system is powered up.
2. Means: Factory mounted actuator factory wired to damper.
3. Portable 9 volt system. No field power requirement.
4. Mounting: Recessed Wall Box or Diffuser or Hand Held.
5. Wall-Box Cover Finish: Coordinate with Architect.
6. Wall-Box Porting: 1 to 6 ports or more.

## 2.11 DUCT-MOUNTED ACCESS DOORS

A. Manufacturers: Subject to compliance with requirements, provide products by one of the following:

1. Greenheck Fan Corporation.
2. McGill AirFlow LLC.
3. Pottorff.
4. Ward Industries, Inc.; a division of Hart & Cooley, Inc.
5. Ruskin Company

B. Duct-Mounted Access Doors: Fabricate access panels according to SMACNA's "HVAC Duct Construction Standards - Metal and Flexible"; Figures 7-2, "Duct Access Doors and Panels," and 7-3, "Access Doors - Round Duct."

1. Door:

- a. Double wall, rectangular.
- b. Galvanized sheet metal with insulation fill and thickness as indicated for duct pressure class.
- c. Vision panel.
- d. Hinges and Latches: 1-by-1-inch butt or piano hinge and cam latches.
- e. Fabricate doors airtight and suitable for duct pressure class.

2. Frame: Galvanized sheet steel, with bend-over tabs and foam gaskets.

3. Number of Hinges and Locks:

- a. Access Doors Less Than 12 Inches Square: No hinges and two sash locks.
- b. Access Doors up to 18 Inches Square:
  - 1) Hinges:
    - a) Two hinges and two sash locks.
- c. Access Doors up to 24 by 48 Inches, provide outside and inside handles:

- 1) Hinges:
  - a) Three hinges and two compression latches.
- d. Access Doors Larger Than 24 by 48 Inches, provide outside and inside handles:
  - 1) Hinges:
    - a) Continuous and two compression latches with outside and inside handles.

## 2.12 FLEXIBLE CONNECTORS

- A. Manufacturers: Subject to compliance with requirements, provide products by one of the following:
  - 1. Ductmate Industries, Inc.
  - 2. Ventfabrics, Inc.
  - 3. Ward Industries, Inc.; a division of Hart & Cooley, Inc.
- B. Materials: Flame-retardant or noncombustible fabrics.
- C. Coatings and Adhesives: Comply with UL 181, Class 1.
- D. Metal-Edged Connectors: Factory fabricated with a wide fabric strip attached to two narrower metal strips. Provide strips of metal compatible with connected ducts.
  - 1. Wide Strip:
    - a. 3-1/2 inches.
  - 2. Narrow Strips:
    - a. 0.028-inch- thick, galvanized sheet steel.
- E. Indoor System, Flexible Connector Fabric: Glass fabric double coated with neoprene.
  - 1. Minimum Weight: 26 oz./sq. yd..
  - 2. Tensile Strength: 530 lbf/inch in the warp and 440 lbf/inch in the filling.
  - 3. Service Temperature: Minus 40 to plus 200 deg F.
- F. Outdoor System, Flexible Connector Fabric: Glass fabric double coated with weatherproof, synthetic rubber resistant to UV rays and ozone.
  - 1. Minimum Weight: 24 oz./sq. yd..
  - 2. Tensile Strength: 530 lbf/inch in the warp and 440 lbf/inch in the filling.
  - 3. Service Temperature: Minus 50 to plus 250 deg F.

## 2.13 FLEXIBLE DUCTS

- A. Manufacturers: Subject to compliance with requirements, provide products by one of the following:
  - 1. Flexmaster U.S.A., Inc.
  - 2. McGill AirFlow LLC.
  - 3. Themaflex
  - 4. Ward Industries, Inc.; a division of Hart & Cooley, Inc.



- B. Ducts shall conform to the requirements for Class I connectors when tested in accordance with "Standard for Factory Made Air Ducts Materials and Air Duct Connectors" (UL 181).
- C. Ducts shall also pass the 15 minute U.L. flame penetration test as specified in the UL 181 Standard.
- D. Insulated, Flexible Duct: Two-ply vinyl film supported by helically wound, spring-steel wire; fibrous-glass insulation; polyethylene or aluminized vapor-barrier film.
  - 1. Pressure Rating: 10-inch wg positive and 1.0-inch wg negative.
  - 2. Maximum Air Velocity: 4000 fpm.
  - 3. Temperature Range: Minus 10 to plus 160 deg F.
  - 4. Insulation R-value: Comply with ASHRAE/IESNA 90.1.
- E. Flexible Duct Connectors:
  - 1. Clamps: in sizes 3 through 18 inches, to suit duct size.
    - a. Material: Stainless-steel band with cadmium-plated hex screw to tighten band with a worm-gear action.

#### 2.14 DUCT ACCESSORY HARDWARE

- A. Instrument Test Holes: Cast iron or cast aluminum to suit duct material, including screw cap and gasket. Size to allow insertion of pitot tube and other testing instruments and of length to suit duct-insulation thickness.
- B. Adhesives: High strength, quick setting, neoprene based, waterproof, and resistant to gasoline and grease.
- C. Splitter Damper Accessories: Zinc-plated damper blade bracket; 1/4-inch, zinc-plated operating rod; and a duct-mounted, ball-joint bracket with flat rubber gasket and square-head set screw.
- D. Flexible Duct Clamps: Stainless-steel band with cadmium-plated hex screw to tighten band with a worm-gear action, in sizes 3 to 18 inches to suit duct size.

#### 2.22 HIGH EFFICIENCY TAKE-OFFS

- A. Manufacturers: Subject to compliance with requirements, provide products by one of the following.
  - 1. Air-Rite
  - 2. Hercules Industries
  - 3. Sheet Metal Connectors, Inc.
  - 4. Spiral Manufacturing Co. Inc.
  - 5. Ferguson
- B. Materials:
  - 1. 24 gauge galvanized sheet metal meeting ASTM A653 and A924

- C. Take-off shall meet SMACNA third edition Section 4.8 figure 4.6 - 45 degree entry.
- D. Rectangular opening with flanged sides on all sides. Complete with closed cell neoprene gasket to provide a tight seal.

### PART 3 - EXECUTION

#### 3.1 INSTALLATION

##### General

- A. Install duct accessories according to applicable details in SMACNA's "HVAC Duct Construction Standards - Metal and Flexible" for metal ducts and in NAIMA AH116, "Fibrous Glass Duct Construction Standards," for fibrous-glass ducts.
- B. Install duct accessories of materials suited to duct materials; use galvanized-steel accessories in galvanized-steel and fibrous-glass ducts, stainless-steel accessories in stainless-steel ducts, and aluminum accessories in aluminum ducts.
- C. Use the Remote Damper Operator when they are called out on the drawings or when the damper cannot be easily accessed.
- D. Install high efficiency take-off on all branch duct take-offs. Provide take-off with balancing damper as shown on drawings. Spin-in fittings are not allowed.

##### Flexible Ducts / Flexible Duct Connectors

- E. Install flexible connectors to connect ducts to equipment.
- F. Flexible duct connections from the main trunk ducts to diffuser boots shall be furnished and installed as shown on the drawings. Flexible ductwork shall only be used as indicated on the drawings.
- G. Where flexible duct is indicated, use insulated flexible duct for supply air return and exhaust air.
- H. Flexible ductwork shall be run in straight lengths.
- I. Provide support in flexible duct every three feet.
- J. Flexible ducts shall have compression fittings on both ends.
- K. Flexible ductwork is not allowed to bend 90 degrees. If a bend is needed use sheet-metal hard elbows. Hard turns, offsets, or kinks will not be allowed.
- L. Flexible ducts shall connect to trunk duct with high efficiency takeoffs.
- M. Connect flexible ducts to metal ducts with draw bands.

- N. Connect ducts to duct silencers:
  - 1. With flexible duct connectors.
- O. Connect terminal units to supply ducts:
  - 1. With maximum 12-inch lengths of flexible duct.
- P. Do not use flexible ducts to change directions.
- Q. Connect diffusers or light troffer boots to ducts:
  - 1. With maximum 60-inch lengths of flexible duct clamped or strapped in place.

#### Backdraft/Control/Pressure Relief Dampers

- R. Install backdraft dampers at inlet of exhaust fans or exhaust ducts as close as possible to exhaust fan unless otherwise indicated.
- S. Install pressure relief damper immediately upstream of main fire damper.

#### Volume Damper

- T. Install volume dampers at points on supply, return, and exhaust systems where branches extend from larger ducts. Where dampers are installed in ducts having duct liner, install dampers with hat channels of same depth as liner, and terminate liner with nosing at hat channel.
  - 1. Install steel volume dampers in steel ducts.
  - 2. Install aluminum volume dampers in aluminum ducts.
- U. Set dampers to fully open position before testing, adjusting, and balancing. Exception: Pressure relief damper.
- V. A balance damper with locking quadrant will be provided downstream of take-off from trunk duct.

#### Fans And Test Holes

- W. For fans developing static pressures of 5-inch wg and more, cover flexible connectors with loaded vinyl sheet held in place with metal straps.
- X. Install thrust limits at centerline of thrust, symmetrical on both sides of equipment. Attach thrust limits at centerline of thrust and adjust to a maximum of 1/4-inch movement during start and stop of fans.
- Y. Install duct test holes where required for testing and balancing purposes.
- Z. Install test holes at fan inlets and outlets and elsewhere as indicated.

#### FIRE, SMOKE AND FIRE-SMOKE DAMPERS

- AA. Install fire and smoke dampers according to UL listing.
  - 1. Install fusible links in fire dampers.

- BB. For round ductwork 24-inch and smaller a true round fire damper with the same rating may be used.

Access Doors

- CC. Install duct access doors on sides of ducts to allow for inspecting, adjusting, and maintaining accessories and equipment at the following locations:
1. On upstream side of duct coils.
  2. Upstream from duct filters.
  3. At outdoor-air intakes and mixed-air plenums.
  4. At drain pans and seals.
  5. Downstream from manual volume dampers, control dampers, backdraft dampers, and equipment.
  6. Adjacent to and close enough to fire or smoke dampers, to reset or reinstall fusible links. Access doors for access to fire or smoke dampers having fusible links shall be standard access doors and shall be outward operation for access doors installed upstream from dampers and inward operation for access doors installed downstream from dampers.
  7. At each change in direction and at maximum 50-foot spacing.
  8. Upstream from turning vanes.
  9. Upstream or downstream from duct silencers.
  10. Control devices requiring inspection.
  11. Elsewhere as indicated.
- DD. Install access doors with swing against duct static pressure.
- EE. Access Door Sizes:
1. One-Hand or Inspection Access: 8 by 5 inches.
  2. Two-Hand Access: 12 by 6 inches.
  3. Head and Hand Access: 18 by 10 inches.
  4. Head and Shoulders Access: 21 by 14 inches.
  5. Body Access: 25 by 14 inches.
  6. Body plus Ladder Access: 25 by 17 inches.
- FF. Label access doors according to Section 230553 "Identification for HVAC Piping and Equipment" to indicate the purpose of access door.

### 3.2 FIELD QUALITY CONTROL

- A. Tests and Inspections:
1. Operate dampers to verify full range of movement.
  2. Inspect locations of access doors and verify that purpose of access door can be performed.
  3. Operate fire, smoke, and combination fire and smoke dampers to verify full range of movement and verify that proper heat-response device is installed.
  4. Inspect turning vanes for proper and secure installation.
  5. Operate remote damper operators to verify full range of movement of operator and damper.

3.3 ADJUSTING

- A. Adjust duct accessories for proper settings.
- B. Adjust fire and smoke dampers for proper action.
- C. Final positioning of manual-volume dampers is specified in Division 23 Section "Testing, Adjusting, and Balancing for HVAC."

END OF SECTION

**SECTION 23 36 00 - AIR TERMINAL UNITS**

## PART 1 - GENERAL

## 1.1 RELATED DOCUMENTS

- A. Drawings and general provisions of the Contract, including General and Supplementary Conditions and Division 01 Specification Sections, apply to this Section.

## 1.2 SUMMARY

- A. Section Includes:
  - 1. Shutoff, single-duct air terminal units.

## 1.3 ACTION SUBMITTALS

- A. Product Data: For each type of the following products, including rated capacities, furnished specialties, sound-power ratings, and accessories.
  - 1. Air terminal units.
  - 2. Liners and adhesives.
  - 3. Sealants and gaskets.
  - 4. Seismic-restraint devices.
- B. Shop Drawings: For air terminal units. Include plans, elevations, sections, details, and attachments to other work.
  - 1. Detail equipment assemblies and indicate dimensions, weights, loads, required clearances, method of field assembly, components, and location and size of each field connection.
  - 2. Wiring Diagrams:
    - a. For power, signal, and control wiring.
    - b. Differentiate between manufacturer-installed and field-installed wiring.
  - 3. Hangers and supports, including methods for duct and building attachment and vibration isolation.
- C. Delegated-Design Submittal:
  - 1. Materials, fabrication, assembly, and spacing of hangers and supports.
  - 2. Design Calculations: Calculations, including analysis data signed and sealed by the qualified professional engineer responsible for their preparation for selecting hangers and supports.

## 1.4 INFORMATIONAL SUBMITTALS

- A. Coordination Drawings: Reflected ceiling plans, drawn to scale, on which the following items are shown and coordinated with each other, using input from Installers of the items involved:
  - 1. Ceiling suspension assembly members.
  - 2. Size and location of initial access modules for acoustic tile.
  - 3. Ceiling-mounted items including lighting fixtures, diffusers, grilles, speakers, sprinklers, access panels, and special moldings.
- B. Field quality-control reports.

## 1.5 PERFORMANCE REQUIREMENTS

- A. Seismic Performance: Air terminal units shall withstand the effects of earthquake motions determined according to SEI/ASCE 7.
  - 1. The term "withstand" means "the unit will remain in place without separation of any parts from the device when subjected to the seismic forces specified and the unit will be fully operational after the seismic event."

## 1.6 CLOSEOUT SUBMITTALS

- A. Operation and Maintenance Data: For air terminal units to include in emergency, operation, and maintenance manuals. In addition to items specified in Section 01 7823 "Operation and Maintenance Data," include the following:
  - 1. Instructions for resetting minimum and maximum air volumes.
  - 2. Instructions for adjusting software set points.

## 1.7 MAINTENANCE MATERIAL SUBMITTALS

- A. Furnish extra materials that match products installed and that are packaged with protective covering for storage and identified with labels describing contents.
  - 1. Fan-Powered-Unit Filters: Furnish one spare filter for each filter installed.

## 1.8 QUALITY ASSURANCE

- A. ASHRAE Compliance: Applicable requirements in ASHRAE 62.1, Section 5 - "Systems and Equipment" and Section 7 - "Construction and System Start-Up."
- B. Product Options: Drawings and schedules indicate requirements of air terminals and are based on specific systems indicated. Other manufacturers' systems with equal performance characteristics may be considered. Refer to Division 1 Section "Substitutions."
- C. Listing and Labeling: Provide electrically operated air terminals specified in this Section that are listed and labeled.

1. The Terms "Listed" and "Labeled": As defined in NFPA 70, Article 100.
- D. NFPA Compliance: Install air terminals according to NFPA 90A, "Standard for the Installation of Air Conditioning and Ventilating Systems."
- E. Comply with NFPA 70 for electrical components and installation.

## PART 2 - PRODUCTS

### 2.1 PERFORMANCE REQUIREMENTS

- A. Structural Performance: Hangers and supports shall withstand the effects of gravity loads and stresses within limits and under conditions described in SMACNA's "HVAC Duct Construction Standards - Metal and Flexible" .

### 2.2 SYSTEM DESCRIPTION

- A. Electrical Components, Devices, and Accessories: Listed and labeled as defined in NFPA 70, by a qualified testing agency, and marked for intended location and application.

### 2.3 SHUTOFF, SINGLE-DUCT AIR TERMINAL UNITS

- A. Manufacturers: Subject to compliance with requirements, provide products by one of the following:
  1. Anemostat Products; a Mestek Company.
  2. Carnes.
  3. Environmental Technologies, Inc.
  4. Krueger.
  5. METALAIRE, Inc.
  6. Nailor Industries Inc.
  7. Price Industries.
  8. Titus.
  9. Trox USA Inc.; a subsidiary of the TROX GROUP.
  10. Tuttle & Bailey.
  11. Warren Technology.
- B. Configuration: Volume-damper assembly inside unit casing with control components inside a protective metal shroud.
- C. Casing: 0.034-inch steel, single wall.
  1. Casing Lining: Adhesive attached, coated, fibrous-glass duct liner complying with ASTM C 1071, and having a maximum flame-spread index of 25 and a maximum smoke-developed index of 50, for both insulation and adhesive, when tested according to ASTM E 84.
    - a. Lining thickness:
      - 1) 1/2-inch-
    - b. Cover liner with nonporous foil.



2. Air Inlet: Round stub connection or S-slip and drive connections for duct attachment.
  3. Air Outlet: S-slip and drive connections.
  4. Air Outlet: S-slip and drive connections size matching inlet size.
  5. Access: Removable panels for access to parts requiring service, adjustment, or maintenance; with airtight gasket.
  6. Access Door: Access door upstream of the reheat coil.
- D. Volume Damper: Galvanized steel with peripheral gasket and self-lubricating bearings.
1. Maximum Damper Leakage:
    - a. ARI 880 rated, 3 percent of nominal airflow at 3-inch wg inlet static pressure.
  2. Damper Position:
    - a. Normally open.
- E. Hydronic Coils: Copper tube, with mechanically bonded aluminum fins spaced no closer than 0.1 inch, and rated for a minimum working pressure of 200 psig and a maximum entering-water temperature of 220 deg F. Include manual air vent and drain valve.
- L. Direct Digital Controls: Bidirectional damper operators and microprocessor-based controller and room sensor. Control devices shall be compatible with temperature controls specified in Section 230900 "Instrumentation and Control for HVAC" and shall have the following features:
1. Damper Actuator: 24 V, powered closed, spring return open.
  2. Terminal Unit Controller: Pressure-independent, variable-air-volume controller with electronic airflow transducer with multipoint velocity sensor at air inlet, factory calibrated to minimum and maximum air volumes, and having the following features:
    - a. Occupied and unoccupied operating mode.
    - b. Remote reset of airflow or temperature set points.
    - c. Adjusting and monitoring with portable terminal.
    - d. Communication with temperature-control system specified in Section 230900 "Instrumentation and Control for HVAC."
  3. Room Sensor: Wall mounted with temperature set-point adjustment and access for connection of portable operator terminal.
- F. Control Sequence:
1. Suitable for operation with duct pressures between 0.25- and 3.0-inch wg inlet static pressure.
  2. System-powered, wall-mounted thermostat.
- 2.4 HANGERS AND SUPPORTS
- A. Hanger Rods for Noncorrosive Environments: Cadmium-plated steel rods and nuts.

- B. Hanger Rods for Corrosive Environments: Electrogalvanized, all-thread rods or galvanized rods with threads painted with zinc-chromate primer after installation.
- C. Steel Cables: Galvanized steel complying with ASTM A 603.
- D. Steel Cable End Connections: Cadmium-plated steel assemblies with brackets, swivel, and bolts designed for duct hanger service; with an automatic-locking and clamping device.
- E. Air Terminal Unit Attachments: Sheet metal screws, blind rivets, or self-tapping metal screws; compatible with duct materials.
- F. Trapeze and Riser Supports: Steel shapes and plates for units with steel casings; aluminum for units with aluminum casings.

## 2.5 SOURCE QUALITY CONTROL

- A. Factory Tests: Test assembled air terminal units according to ARI 880.
  - 1. Label each air terminal unit with plan number, nominal airflow, maximum and minimum factory-set airflows, and ARI certification seal.

## PART 3 - EXECUTION

### 3.1 INSTALLATION

- A. Install air terminal units according to NFPA 90A, "Standard for the Installation of Air Conditioning and Ventilating Systems."
- B. Install air terminal units level and plumb. Maintain sufficient clearance for normal service and maintenance.
- C. Install wall-mounted thermostats.
- D. Install discharge air temperature sensors at the outlet of each Air Terminal Unit.
- E. Connect ductwork to air terminals according to Division 23 ductwork Sections.
- F. Comply with SEI/ASCE 7 and with requirements for seismic-restraint devices in Section 230548 "Vibration and Seismic Controls for HVAC."

### 3.2 HANGER AND SUPPORT INSTALLATION

- A. Comply with SMACNA's "HVAC Duct Construction Standards - Metal and Flexible," Chapter 5, "Hangers and Supports."
- B. Building Attachments: Concrete inserts, powder-actuated fasteners, or structural-steel fasteners appropriate for construction materials to which hangers are being attached.

1. Where practical, install concrete inserts before placing concrete.
  2. Install powder-actuated concrete fasteners after concrete is placed and completely cured.
  3. Use powder-actuated concrete fasteners for standard-weight aggregate concretes and for slabs more than 4 inches thick.
  4. Do not use powder-actuated concrete fasteners for lightweight-aggregate concretes and for slabs less than 4 inches thick.
  5. Do not use powder-actuated concrete fasteners for seismic restraints.
- C. Hangers Exposed to View: Threaded rod and angle or channel supports.
- D. Install upper attachments to structures. Select and size upper attachments with pull-out, tension, and shear capacities appropriate for supported loads and building materials where used.

### 3.3 CONNECTIONS

- A. Install piping adjacent to air terminal unit to allow service and maintenance.
- B. Hot-Water Piping: In addition to requirements in Section 232113 "Hydronic Piping" and Section 232116 Hydronic Piping Specialties," connect heating coils to supply with shutoff valve, strainer, control valve, and union or flange; and to return with balancing valve and union or flange.
- C. Connect ducts to air terminal units according to Section 233113 "Metal Ducts.
- D. Electrically ground all equipment:
1. Tighten electrical connectors and terminals according to manufacturer's published torque-tightening values. Where manufacturer's torque values are not indicated, use those specified in UL 486A and UL 486B.

### 3.4 IDENTIFICATION

- A. Label each air terminal unit with plan number, nominal airflow, and maximum and minimum factory-set airflows. Comply with requirements in Section 230553 "Identification for HVAC Piping and Equipment" for equipment labels and warning signs and labels.

### 3.5 FIELD QUALITY CONTROL

- A. Testing Agency: Owner will engage a qualified testing agency to perform tests and inspections.
- B. Manufacturer's Field Service: Engage a factory-authorized service representative to inspect, test, and adjust components, assemblies, and equipment installations, including connections.
- C. Perform tests and inspections.

1. Manufacturer's Field Service: Engage a factory-authorized service representative to inspect components, assemblies, and equipment installations, including connections, and to assist in testing.

D. Tests and Inspections:

1. After installing air terminal units and after electrical circuitry has been energized, test for compliance with requirements.
2. Leak Test: After installation, fill water coils and test for leaks. Repair leaks and retest until no leaks exist.
3. Operational Test: After electrical circuitry has been energized, start units to confirm proper motor rotation and unit operation.
4. Test and adjust controls and safeties. Replace damaged and malfunctioning controls and equipment.

E. Air terminal unit will be considered defective if it does not pass tests and inspections.

F. Prepare test and inspection reports.

G. Cleaning:

1. After completing system installation, including outlet fittings and devices, inspect exposed finish. Remove burrs, dirt, and construction debris, and repair damaged finishes.

### 3.6 STARTUP SERVICE

A. Engage a factory-authorized service representative to perform startup service.

1. Complete installation and startup checks according to:
  - a. Manufacturer's written instructions.
  - b. Construction documents.
2. Verify that inlet duct connections are as recommended by air terminal unit manufacturer to achieve proper performance.
3. Verify that controls and control enclosure are accessible.
4. Verify that control connections are complete.
5. Verify that nameplate and identification tag are visible.
6. Verify that controls respond to inputs as specified.

### 3.7 DEMONSTRATION

A. Engage a factory-authorized service representative to train Owner's maintenance personnel to adjust, operate, and maintain air terminal units:

1. Train Owner's maintenance personnel on procedures and schedules related to startup and shutdown, troubleshooting, servicing, and preventive maintenance.
2. Review data in the maintenance manuals. Refer to Division 1 Section "Contract Closeout."
3. Review data in the maintenance manuals. Refer to Division 1 Section "Operation and Maintenance Data."

4. Schedule training with Owner, through Architect, with at least 7 days' advance notice.

END OF SECTION

**SECTION 23 37 13 - DIFFUSERS, REGISTERS, AND GRILLES**

## PART 1 - GENERAL

## 1.1 RELATED DOCUMENTS

- A. Drawings and general provisions of the Contract, including General and Supplementary Conditions and Division 01 Specification Sections, apply to this Section.

## 1.2 SUMMARY

- A. This section includes ceiling- and wall-mounted diffusers, registers, and grilles.
- B. Related Sections:
  - 1. Section 233714 "Fixed Louvers" for fixed and louvers and wall vents, whether or not they are connected to ducts.
  - 2. Section 233300 "Air Duct Accessories" for fire and smoke dampers and volume-control dampers not integral to diffusers, registers, and grilles.
  - 3. Section 230594 "General Testing, Adjusting and Balancing" for balancing diffusers, registers, and grilles.

## 1.3 ACTION SUBMITTALS

- A. Product Data: For each type of product indicated, include the following:
  - 1. Data Sheet: Indicate materials of construction, finish, and mounting details; and performance data including throw and drop, static-pressure drop, and noise ratings.
  - 2. Diffuser, Register, and Grille Schedule: Indicate drawing designation, room location, quantity, model number, size, and accessories furnished.

## 1.4 INFORMATIONAL SUBMITTALS

- A. Coordination Drawings: Reflected ceiling plans, drawn to scale, on which the following items are shown and coordinated with each other, using input from Installers of the items involved:
  - 1. Ceiling suspension assembly members.
  - 2. Method of attaching hangers to building structure.
  - 3. Size and location of initial access modules for acoustical tile.
  - 4. Ceiling-mounted items including lighting fixtures, diffusers, grilles, speakers, sprinklers, access panels, and special moldings.
  - 5. Duct access panels.
- B. Source quality-control reports.

## 1.5 QUALITY ASSURANCE

- A. Product Options: Drawings and schedules indicate specific requirements of diffusers, registers, and grilles and are based on the specific requirements of the systems indicated.
- B. NFPA Compliance: Install diffusers, registers, and grilles according to NFPA 90A, "Standard for the Installation of Air-Conditioning and Ventilating Systems."

## PART 2 - PRODUCTS

## 2.1 MANUFACTURERS

- A. Manufacturers: Subject to compliance with requirements, provide products by one of the following:
  - 1. Air Factors
  - 2. Carnes.
  - 3. Kruegar.
  - 4. METALAIRE, Inc.
  - 5. Nailor Industries Inc.
  - 6. Price Industries.
  - 7. Titus.
  - 8. Tuttle & Bailey.

## 2.2 REGISTERS, GRILLES, &amp; DIFFUSERS

- A. General: The frames for all registers, grilles, and diffusers shall match type of ceiling where they are to be installed. Special frames shall be provided for narrow T-bar ceilings. Refer to reflected ceiling plan and other specification divisions for ceiling type. See drawings AND schedules for additional information.

## 2.3 SOURCE QUALITY CONTROL

- A. Verification of Performance: Rate diffusers, registers, and grilles according to ASHRAE 70, "Method of Testing for Rating the Performance of Air Outlets and Inlets."

## PART 3 - EXECUTION

## 3.1 EXAMINATION

- A. Examine areas where diffusers, registers, and grilles are to be installed for compliance with requirements for installation tolerances and other conditions affecting performance of equipment.
- B. Proceed with installation only after unsatisfactory conditions have been corrected.

### 3.2 INSTALLATION

- A. Install diffusers, registers, and grilles level and plumb, according to manufacturer's written instructions, coordination drawings, original design, and referenced standards.
- B. Ceiling-Mounted Outlets and Inlets: Drawings indicate general arrangement of ducts, fittings, and accessories. Air outlet and inlet locations have been indicated to achieve design requirements for air volume, noise criteria, airflow pattern, throw, and pressure drop. Make final locations where indicated, as much as practical. For units installed in lay-in ceiling panels, locate units in the center of panel. Where architectural features or other items conflict with installation, notify Architect for a determination of final location.
- C. Install diffusers, registers, and grilles with airtight connections to ducts and to allow service and maintenance of dampers, air extractors, and fire dampers.

### 3.3 ADJUSTING

- A. After installation, adjust diffusers, registers, and grilles to air patterns indicated, or as directed, before starting air balancing.

### 3.4 CLEANING

- A. After installation of diffusers, registers, and grilles, inspect exposed finish. Clean exposed surfaces to remove burrs, dirt, and smudges. Replace diffusers, registers, and grilles that have damaged finishes.

END OF SECTION



Division	Section Title	Pages
----------	---------------	-------

**SPECIFICATIONS GROUP**

*Facility Services Subgroup*

**DIVISION 26 - ELECTRICAL**

260519	LOW-VOLTAGE ELECTRICAL POWER CONDUCTORS AND CABLES	7
260526	GROUNDING AND BONDING FOR ELECTRICAL SYSTEMS	6
260529	HANGERS AND SUPPORTS FOR ELECTRICAL SYSTEMS	6
260533	RACEWAYS AND BOXES FOR ELECTRICAL SYSTEMS	9
260544	SLEEVES AND SLEEVE SEALS FOR ELECTRICAL SYSTEMS	4
260553	IDENTIFICATION FOR ELECTRICAL SYSTEMS	7
260923	LIGHTING CONTROL DEVICES	9
262726	WIRING DEVICES	9
265119	LED INTERIOR LIGHTING	10

**DIVISION 27 - COMMUNICATIONS**

270000	COMMON GENERAL CONDITIONS FOR COMMUNICATIONS SECTIONS	9
270100	OPERATION AND MAINTENANCE OF COMMUNICATION SYSTEMS	2
270113	WARRANTY PRODUCT AND SYSTEM	2
270119	FIELD TESTING AND REPORTING	5
270133	SHOP DRAWINGS PRODUCT DATA SAMPLES DESIGN RECORDS AND EXISTING CONDITIONS	3
270143	QUALIFICATIONS AND REQUIRED TRAINING FOR CONTRACTOR AND INSTALLER	1
270171	RESPONSIBILITY AND WORKMANSHIP OF CONTRACTOR	2
270500	COMMON WORK RESULTS FOR COMMUNICATIONS	2
270526	GROUNDING AND BONDING FOR COMMUNICATIONS SYSTEMS	2
270528	PATHWAYS FOR COMMUNICATIONS SYSTEMS	4
270529	HANGERS AND SUPPORTS FOR COMMUNICATIONS SYSTEMS	1
270533	CONDUITS AND BACK BOXES FOR COMMUNICATION SYSTEMS	2
270536	CABLE TRAYS FOR COMMUNICATIONS SYSTEMS	5
270543	CAMPUS CABLE ROUTING	2
270553	IDENTIFICATION FOR LOW-VOLTAGE CABLES AND LABELING	3
271100	EQUIPMENT ROOM FITTINGS	10
271116	CABINETS, RACKS, FRAMES, AND ENCLOSURES	1
271119	TERMINATION BLOCKS AND PATCH PANELS	2
271300	BACKBONE CABLING	2
271500	HORIZONTAL CABLING	4
271513	COPPER CABLE	1
271543	FACEPLATES AND CONNECTORS	2
271619	PATCH CABLES	1
274133	MASTER ANTENNA TELEVISION SYSTEM	10
275113	OVERHEAD PAGING	3

275319	INTERNAL CELLULAR PAGING AND ANTENNA SYSTEMS	1
276001	APPENDIX 01 DEVIATION REQUEST PROCESS	2
276002	APPENDIX 02 DOCUMENT REFRESH PROCESS	1
276003	APPENDIX 03 DATA CENTER, TEC, TDR PART NUMBERS	2
276004	APPENDIX 04 REFERENCE STANDARDS	2
276005	APPENDIX 05 DEFINITIONS AND ABBREVIATIONS	2
276006	APPENDIX 06 MATERIAL SUPPLIERS	1
276007	APPENDIX 07 SIEMON - CERTIFIED INSTALLATION FIRMS	4
276008	APPENDIX 08 LEAD WALL PENETRATIONS	2
<b>DIVISION 28 - ELECTRONIC SAFETY AND SECURITY</b>		
283111	DIGITAL, ADDRESSABLE FIRE ALARM SYSTEM	14

**END OF TABLE OF CONTENTS**

**SECTION 26 05 19**  
**LOW-VOLTAGE ELECTRICAL POWER CONDUCTORS AND CABLES**

**PART 1 - GENERAL**

**1.1 RELATED DOCUMENTS**

- A. Drawings and general provisions of the Contract, including General and Supplementary Conditions and Division 01 Specification Sections, apply to this Section.

**1.2 SUMMARY**

- A. Section Includes:
1. Building wires and cables rated 600 V and less.
  2. Connectors, splices, and terminations rated 600 V and less.
- B. Related Requirements:
1. Section 26 05 33 "Raceways and Boxes for Electrical Systems"
  2. Section 26 09 23 "Lighting Control Devices"
  3. Section 26 09 36 "Standalone Modular Preset Dimming Controls"
  4. Section 26 09 43 "Relay-Based Lighting Controls"
  5. Section 27 41 33 "Master Antenna Television System"
  6. Section 27 51 17 "Networked Public Address and Paging System"
  7. Section 27 51 19 "Sound Masking Systems"
  8. Section 28 13 00 "Access Control"
  9. Section 28 31 11 "Digital, Addressable Fire-Alarm System"
  10. Section 27 00 00 "Intermountain Healthcare Networked Structured Cable & Standards" for cabling used for voice and data circuits.

**1.3 DEFINITIONS**

- A. Outlet Box: Electrical box used to support utilization equipment such as a receptacle or light fixture.
- B. Pull Box: Electrical box through which branch circuit or feeder conductors are run but are not spliced.
- C. Junction Box: Electrical box used for splicing branch circuit or feeder conductors.
- D. Multiwire Branch Circuit: A branch circuit as defined by the National Electrical Code that shares a grounded conductor between two of more phase conductors.

**1.4 ACTION SUBMITTALS**

- A. Product Data: For each type of product.

**1.5 INFORMATIONAL SUBMITTALS**

- A. Field quality-control reports.

**PART 2 - PRODUCTS****2.1 SINGLE CONDUCTORS**

- A. Manufacturers: Subject to compliance with requirements, available manufacturers offering products that may be incorporated into the Work include, but are not limited to the following:
1. Alpha Wire Company.
  2. Belden Inc.
  3. Cerro Wire LLC.
  4. Encore Wire Corporation.
  5. General Cable; General Cable Corporation.
  6. Southwire Company.
  7. Thomas & Betts Corporation; A Member of the ABB Group.
- B. Aluminum and Copper Conductors: Comply with NEMA WC 70/ICEA S-95-658.
- C. Conductor Insulation: Comply with NEMA WC 70/ICEA S-95-658 for Type THHN/THWN-2, Type XHHW-2 and Type SO.

**2.2 MULTI-CONDUCTOR CABLES**

- A. Manufacturers: Subject to compliance with requirements, available manufacturers offering products that may be incorporated into the Work include, but are not limited to the following:
1. Southwire Company.
  2. AFC Cable Systems.
- B. Copper Conductors: Comply with NEMA WC 70/ICEA S-95-658.
- C. Conductor Insulation: Comply with NEMA WC 70/ICEA S-95-658 for Type THHN/THWN-2, Type XHHW-2 and Type SO.
- D. Multi-conductor Cable, Type AC-HCF:
1. Armor: Galvanized Interlocking Steel Strip (green striped or solid green).
  2. Conductors: Solid Copper
  3. Conductor Insulation: THHN-2 with individual moisture resistant, fire retardant paper wrap on each individual conductor.
  4. Grounding: 16 AWG integral bond wire and insulated green copper grounding conductor.
  5. Neutral (Grounded) Conductor: White for 120Y/208 volt systems and Grey 480Y/277 volt systems.
  6. Maximum Voltage Rating: 600 volts.
  7. References and Ratings:
    - a. UL 4, 83, 1479, 1581, 2556, File Reference E7330
    - b. NEC 250.118(8), 300.22(C), 392, 320, 517.13, 518, 645
    - c. Federal Specification A-A-59544 (formerly J-C-30B)
    - d. UL Classified 1, 2, and 3-hour through (Fire) penetration product, R-14141
    - e. Environmental Air-Handling Space Installation per NEC 300.22(C)

- E. Other Multi-conductor Cable: Comply with NEMA WC 70/ICEA S-95-658 for Type SO with ground wire.

### 2.3 CONNECTORS AND SPLICES

- A. Manufacturers: Subject to compliance with requirements, available manufacturers offering products that may be incorporated into the Work include, but are not limited to the following:
  - 1. 3M.
  - 2. AFC Cable Systems; a part of Atkore International.
  - 3. Hubbell Power Systems, Inc.
  - 4. Ideal Industries, Inc.
  - 5. ILSCO.
  - 6. O-Z/Gedney; a brand of Emerson Industrial Automation.
- B. Description: Factory-fabricated connectors and splices of size, ampacity rating, material, type, and class for application and service indicated.

### 2.4 CORD REELS

- A. Manufacturers: Subject to compliance with requirements, available manufacturers offering products that may be incorporated into the Work include, but are not limited to the following:
  - 1. APC Group; Kitchen Leash
- B. Case (housing):
  - 1. Dimensions: 9" x 12" x 3'
  - 2. Material: Molded Polypropylene 3.175 mm thickness
  - 3. 94v-2 flammability rating
- C. Power Cord
  - 1. Conductors: 14/3 AWG copper type SJOW
  - 2. Length: 10 feet
  - 3. Rating: 200 degrees F
- D. Receptacle/Plug
  - 1. Rated: 125vac/20 amp
  - 2. Receptacle: NEMA 5-15P
  - 3. Plug: Dual Duplex rated 20 amp
- E. Mounting Bracket: Designed for installation on the ceiling type where the cord reel will be installed.

### 2.5 SYSTEM DESCRIPTION

- A. Electrical Components, Devices, and Accessories: Listed and labeled as defined in NFPA 70, by a qualified testing agency, and marked for intended location and application.
- B. Comply with NFPA 70.

**2.6 FIRE-ALARM WIRE AND CABLE**

- A. General Wire and Cable Requirements: NRTL listed and labeled as complying with NFPA 70, Article 760.
- B. Signaling Line Circuits: Twisted, shielded pair, size as recommended by system manufacturer.
  - 1. Circuit Integrity Cable: Twisted shielded pair, NFPA 70, Article 760, Classification CI, for power-limited fire-alarm signal service Type FPL. NRTL listed and labeled as complying with UL 1424 and UL 2196 for a two-hour rating.
- C. Non-Power-Limited Circuits: Solid-copper conductors with 600-V rated, 75 deg C, color-coded insulation, and complying with requirements in UL 2196 for a two-hour rating.
  - 1. Low-Voltage Circuits: No. 14 AWG, minimum, in pathway.
  - 2. Line-Voltage Circuits: No. 12 AWG, minimum, in pathway.

**PART 3 - EXECUTION****3.1 CONDUCTOR MATERIAL APPLICATIONS**

- A. Feeders: Copper for feeders smaller than No. 4 AWG; for feeders No. 4 AWG and larger provide copper feeders unless aluminum is specifically indicated on the one-line diagrams. Solid for No. 10 AWG and smaller; stranded for No. 8 AWG and larger. Aluminum conductors may not be installed for circuiting to imaging and mechanical equipment.
- B. Branch Circuits: Copper. Solid or stranded for No. 10 AWG and smaller; stranded for No. 8 AWG and larger.

**3.2 CONDUCTOR INSULATION AND MULTICONDUCTOR CABLE APPLICATIONS AND WIRING METHODS**

- A. Refer to Section 26 05 33 "Raceways and Boxes for Electrical Systems" for raceway types and applications.
- B. Exposed Feeders: Type THHN/THWN-2, single conductors in raceway.
- C. Feeders Concealed in Ceilings, Walls, Partitions, and Crawlspace: Type THHN/THWN-2, single conductors in raceway.
- D. Feeders below Slabs-On-Grade, and Underground: Type THWN-2, single conductors in raceway.
- E. Multiwire Circuits: may not be used for branch circuit wiring. All 120 volt and 277 volt circuits shall be provided with a dedicated grounded conductor (neutral) for each phase conductor. Up to three of these circuits may be installed in a single conduit but not more than one conductor of each phase may be installed in a single conduit.
- F. Branch Circuits Concealed in Ceilings, Walls, and Partitions: Type THHN/THWN-2, single conductors in raceway.
  - 1. Armored cable, Type AC-HCF may be installed for normal and equipment system single branch circuits concealed in walls, and partitions in lengths between outlet boxes 30' or less and not as homeruns or wiring between pullboxes or junction boxes.

2. Armored cable, Type AC-HCF may be installed between the first outlet box concealed in a wall or partition and a junction box above an accessible ceiling immediately above the location where the cable exits the wall or partition framing.
- G. Branch Circuits below Slabs-on-Grade and Underground: Type THHN/THWN-2, single conductors in raceway. Installation of raceways within any concrete slab or composite concrete and steel deck is prohibited. NEC 517.13 (A) requires that all branch circuits serving patient care areas are provided with an effective ground-fault current path by installation in a metal raceway system, or a cable having a metallic armor or sheath assembly that qualifies as an equipment grounding conductor. Metallic raceways are not a specified raceway for branch circuits installed below slabs-on-grade. To assure compliance with the NEC requirement, both initially and when remodels occur in the future, the installation of branch circuit wiring under slabs-on-grade is limited to circuits supplying only the following rooms and area types without extension beyond the room or area to a room or area not listed here:
  1. Mechanical Spaces.
  2. Electrical Rooms.
  3. Food Service.
- H. Branch circuit wiring may also be installed under slabs-on-grade to supply power for the following:
  1. Systems Furniture.
  2. Floor Boxes.
  3. Direct wired equipment that is not located against a wall.
- I. Cord Drops and Portable Appliance Connections: Type SO, hard service cord with stainless-steel, wire-mesh, strain-relief device at terminations to suit application.
- J. Isolated Power System Conductors: #10 AWG, Type XHHW-2 stranded with cross-linked PE insulation and a dielectric constant of 3.5 or less, installed in EMT conduit. To limit leakage-current the branch circuit conductors must be reduced to the shortest overall length possible. Install conduits for Isolated Power System branch circuits in the most direct path between the panel and the outlet box, which is not necessarily parallel and perpendicular to the structure and framing, to reduce conductor length. Install only one circuit in per conduit. Do not use pulling compounds when installing the branch circuit conductors of Isolated Power Systems.

### **3.3 INSTALLATION OF CONDUCTORS AND CABLES**

- A. Conceal cables in finished walls, ceilings, and floors unless otherwise indicated.
- B. Complete raceway installation between conductor and cable termination points according to Section 26 05 33 "Raceways and Boxes for Electrical Systems" prior to pulling conductors and cables.
- C. Use manufacturer-approved pulling compound or lubricant where necessary; compound used must not deteriorate conductor or insulation. Do not exceed manufacturer's recommended maximum pulling tensions and sidewall pressure values. Do not use pulling compounds or lubricant for installation of branch circuit conductors for Isolated Power Systems.
- D. Use pulling means, including fish tape, cable, rope, and basket-weave wire/cable grips, that will not damage cables or raceway.
- E. Install exposed cables parallel and perpendicular to surfaces of exposed structural members, and follow surface contours where possible.

- F. Support cables according to Section 26 05 29 "Hangers and Supports for Electrical Systems."

### **3.4 CORD REELS**

- A. Coordinate location of cord reels to align with kitchen equipment supplied by the cord reel.
- B. Fasten brackets to structure using minimum 3/8" threaded rod and to rigidly support the cord reel. Minimum of 2 rods per bracket with addition if required to provide a rigid support.
- C. Adjust cord stopper as coordinated with owner.

### **3.5 CONNECTIONS**

- A. Tighten electrical connectors and terminals according to manufacturer's published torque-tightening values. If manufacturer's torque values are not indicated, use those specified in UL 486A-486B.
- B. Make splices, terminations, and taps that are compatible with conductor material and that possess equivalent or better mechanical strength and insulation ratings than unspliced conductors.
  - 1. Use oxide inhibitor in each splice, termination, and tap for aluminum conductors.
- C. Wiring at Outlets: Install conductor at each outlet, with at least 12 inches (300 mm) of slack.
- D. Comply with requirements in Section 283111 "Digital, Addressable Fire-Alarm System" for connecting, terminating, and identifying wires and cables.

### **3.6 IDENTIFICATION**

- A. Identify and color-code conductors and cables according to Section 26 05 53 "Identification for Electrical Systems."
- B. Identify each spare conductor at each end with panel and circuit number and identify as spare conductor.

### **3.7 SLEEVE AND SLEEVE-SEAL INSTALLATION FOR ELECTRICAL PENETRATIONS**

- A. Install sleeves and sleeve seals at penetrations of exterior floor and wall assemblies. Comply with requirements in Section 26 05 44 "Sleeves and Sleeve Seals for Electrical Raceways and Cabling."

### **3.8 FIRESTOPPING**

- A. Apply firestopping to electrical penetrations of fire-rated floor and wall assemblies to restore original fire-resistance rating of assembly according to Section 07 84 13 "Penetration Firestopping."

### **3.9 FIELD QUALITY CONTROL**

- A. Perform the following tests and inspections:



1. After installing conductors and cables and before electrical circuitry has been energized, test feeder conductors and conductors feeding the following critical equipment and services for compliance with requirements.
    - a. Imaging Equipment
  2. Infrared Scanning: After Substantial Completion, but not more than 60 days after Final Acceptance, perform an infrared scan of each splice in conductors No. 3 AWG and larger. Remove box and equipment covers so splices are accessible to portable scanner. Correct deficiencies determined during the scan.
    - a. Follow-up Infrared Scanning: Perform an additional follow-up infrared scan of each splice 11 months after date of Substantial Completion.
    - b. Instrument: Use an infrared scanning device designed to measure temperature or to detect significant deviations from normal values. Provide calibration record for device.
    - c. Record of Infrared Scanning: Prepare a certified report that identifies splices checked and that describes scanning results. Include notation of deficiencies detected, remedial action taken, and observations after remedial action.
- B. Test and Inspection Reports: Prepare a written report to record the following:
1. Procedures used.
  2. Results that comply with requirements.
  3. Results that do not comply with requirements and corrective action taken to achieve compliance with requirements.
- C. Cables will be considered defective if they do not pass tests and inspections.

END OF SECTION

**SECTION 26 05 26**  
**GROUNDING AND BONDING FOR ELECTRICAL SYSTEMS**

**PART 1 - GENERAL**

**1.1 RELATED DOCUMENTS**

- A. Drawings and general provisions of the Contract, including General and Supplementary Conditions and Division 01 Specification Sections, apply to this Section.

**1.2 SUMMARY**

- A. Section includes grounding and bonding systems and equipment.
- B. Section includes grounding and bonding systems and equipment, plus the following special applications:
  - 1. Installation and Bonding of Grounding Electrodes including:
    - a. Metal Underground Water Pipe
    - b. Metal Frame of the Structure
    - c. Concrete-Encased Electrodes including UFER Grounds
    - d. Ground Ring
    - e. Rod Electrodes
  - 2. Ground bonding common with lightning protection system.
  - 3. Foundation steel electrodes.
  - 4. Electrical Room Ground Bus.

**1.3 ACTION SUBMITTALS**

- A. Product Data: For each type of product indicated.

**1.4 INFORMATIONAL SUBMITTALS**

- A. As-Built Data: Plans showing dimensioned as-built locations of grounding features specified in "Field Quality Control" Article, including the following:
  - 1. Test wells.
  - 2. Grounding Electrodes
  - 3. Bonding Jumpers
  - 4. Electrical Room Grounding Bus.
  - 5. TEC and TDR Grounding Bus.
- B. Field quality-control reports.

**1.5 CLOSEOUT SUBMITTALS**

- A. Operation and Maintenance Data: For grounding to include in emergency, operation, and maintenance manuals.

1. In addition to items specified in Section 01 78 23 "Operation and Maintenance Data," include the following:
  - a. Instructions for periodic testing and inspection of grounding features at test wells based on NFPA 70B.
    - 1) Tests shall determine if ground-resistance or impedance values remain within specified maximums, and instructions shall recommend corrective action if values do not.
    - 2) Include recommended testing intervals.

## 1.6 QUALITY ASSURANCE

- A. Electrical Components, Devices, and Accessories: Listed and labeled as defined in NFPA 70, by a qualified testing agency, and marked for intended location and application.
- B. Comply with UL 467 for grounding and bonding materials and equipment.

## PART 2 - PRODUCTS

### 2.1 SYSTEM DESCRIPTION

- A. Electrical Components, Devices, and Accessories: Listed and labeled as defined in NFPA 70, by a qualified testing agency, and marked for intended location and application.
- B. Comply with UL 467 for grounding and bonding materials and equipment.

### 2.2 CONDUCTORS

- A. Insulated Conductors: Copper or tinned-copper wire or cable insulated for 600 V unless otherwise required by applicable Code or authorities having jurisdiction.
- B. Bare Copper Conductors:
  1. Stranded Conductors: ASTM B 8.
  2. Tinned Conductors: ASTM B 33.
  3. Bonding Cable: 28 kcmil, 14 strands of No. 17 AWG conductor, 1/4 inch (6 mm) in diameter.
- C. Electrical Room Grounding Bus: Predrilled rectangular bars of annealed copper, 1/4 by 4 inches (6.3 by 100 mm) in cross section, with 9/32-inch (7.14-mm) holes spaced 1-1/8 inches (28 mm) apart. Stand-off insulators for mounting shall comply with UL 891 for use in switchboards, 600 V and shall be Lexan or PVC, impulse tested at 5000 V. Length as required for all specified terminations plus 25% spare but not less than 20 inches.
- D. TEC and TDR Grounding Bus: Predrilled rectangular bars of annealed copper, 1/4 by 4 inches (6.3 by 100 mm) in cross section, with 9/32-inch (7.14-mm) holes spaced 1-1/8 inches (28 mm) apart. Stand-off insulators for mounting shall comply with UL 891 for use in switchboards, 600 V and shall be Lexan or PVC, impulse tested at 5000 V. Length as required for all specified terminations plus 25% spare but not less than 12 inches.

### 2.3 CONNECTORS

- A. Listed and labeled by an NRTL acceptable to authorities having jurisdiction for applications in which used and for specific types, sizes, and combinations of conductors and other items connected.
- B. Bolted Connectors for Conductors and Pipes: Copper or copper alloy.
- C. Welded Connectors: Exothermic-welding kits of types recommended by kit manufacturer for materials being joined and installation conditions.
- D. Bus-Bar Connectors: Mechanical type, cast silicon bronze, solderless compression-type wire terminals, and long-barrel, two-bolt connection to ground bus bar.

### 2.4 GROUNDING ELECTRODES

- A. Ground Rods: Copper-clad steel; 3/4 inch by 10 feet (19 mm by 3 m).

## PART 3 - EXECUTION

### 3.1 APPLICATIONS

- A. Conductors: Install stranded conductors unless otherwise indicated.
- B. Underground Grounding Conductors: Install bare tinned-copper conductor, No. 4/0 AWG minimum.
  - 1. Bury at least 18 inches (600 mm) below grade.
- C. Isolated Grounding Conductors: Green-colored insulation with continuous yellow stripe. On feeders with isolated ground, identify grounding conductor where visible to normal inspection, with alternating bands of green and yellow tape, with at least three bands of green and two bands of yellow.
- D. Grounding Bus: Install in Normal Power Electrical Room, Essential Power Electrical Room, TEC and all TDR. Install bus horizontally, on insulated spacers 2 inches (50 mm) minimum from wall, 96 inches (2400 mm) above finished floor unless otherwise indicated.
- E. Conductor Terminations and Connections:
  - 1. Pipe Terminations: Bolted connectors.
  - 2. Underground Connections: Welded connectors except at test wells and as otherwise indicated.
  - 3. Connections to Ground Rods at Test Wells: Bolted connectors.
  - 4. Connections to Structural Steel: Welded connectors.

### 3.2 GROUNDING UNDERGROUND DISTRIBUTION SYSTEM COMPONENTS

- A. Comply with IEEE C2 grounding requirements.
- B. Pad-Mounted Transformers and Switches: Install tinned-copper conductor not less than No. 4/0 AWG from equipment grounding terminals to ground ring. Bury ground ring not less 18 inches below finished grade.

### 3.3 EQUIPMENT GROUNDING

- A. Install insulated equipment grounding conductors with all feeders and branch circuits.
- B. Install insulated equipment grounding conductors with the following items, in addition to those required by NFPA 70:
  - 1. Feeders and branch circuits.
  - 2. Lighting circuits.
  - 3. Receptacle circuits.
  - 4. Single-phase motor and appliance branch circuits.
  - 5. Three-phase motor and appliance branch circuits.
  - 6. Flexible raceway runs.
  - 7. Armored and metal-clad cable runs.
  - 8. Busway Supply Circuits: Install insulated equipment grounding conductor from grounding bus in the switchgear, switchboard, or distribution panel to equipment grounding bar terminal on busway.
  - 9. X-Ray Equipment Circuits: Install insulated equipment grounding conductor in circuits supplying x-ray equipment.
- C. Air-Duct Equipment Circuits: Install insulated equipment grounding conductor to duct-mounted electrical devices operating at 120 V and more, including air cleaners, heaters, dampers, humidifiers, and other duct electrical equipment. Bond conductor to each unit and to air duct and connected metallic piping.
- D. Water Heater, Heat-Tracing, and Antifrost Heating Cables: Install a separate insulated equipment grounding conductor to each electric water heater and heat-tracing cable. Bond conductor to heater units, piping, connected equipment, and components.
- E. Isolated Grounding Receptacle Circuits: Install an insulated equipment grounding conductor connected to the receptacle grounding terminal. Isolate conductor from raceway and from panelboard grounding terminals. Terminate at equipment grounding conductor terminal of the applicable derived system or service unless otherwise indicated.
- F. Isolated Equipment Enclosure Circuits: For designated equipment supplied by a branch circuit or feeder, isolate equipment enclosure from supply circuit raceway with a nonmetallic raceway fitting listed for the purpose. Install fitting where raceway enters enclosure, and install a separate insulated equipment grounding conductor. Isolate conductor from raceway and from panelboard grounding terminals. Terminate at equipment grounding conductor terminal of the applicable derived system or service unless otherwise indicated.
- G. Metallic Fences: Comply with requirements of IEEE C2.
  - 1. Grounding Conductor: Bare, tinned copper, not less than No. 8 AWG.
  - 2. Gates: Shall be bonded to the grounding conductor with a flexible bonding jumper.

### 3.4 INSTALLATION

- A. Grounding Conductors: Route along shortest and straightest paths possible unless otherwise indicated or required by Code. Avoid obstructing access or placing conductors where they may be subjected to strain, impact, or damage.
- B. Ground Bonding Common with Lightning Protection System: Comply with NFPA 780 and UL 96 when interconnecting with lightning protection system. Bond electrical power system ground directly to lightning protection system grounding conductor at closest point to electrical service

- grounding electrode. Use bonding conductor sized same as system grounding electrode conductor, and install in conduit.
- C. Ground Rods: Drive rods until tops are **2 inches (50 mm)** below finished floor or final grade unless otherwise indicated.
1. Interconnect ground rods with grounding electrode conductor below grade and as otherwise indicated. Make connections without exposing steel or damaging coating if any.
- D. Test Wells: Ground rod driven through drilled hole in bottom of handhole. Handholes are shall be at least **12 inches (300 mm)** deep, with cover.
1. Test Wells: Install one test well at the ground rod location indicated on the drawings.
- E. Bonding Straps and Jumpers: Install in locations accessible for inspection and maintenance except where routed through concrete footings.
1. Bonding to Structure: Bond straps directly to basic structure, taking care not to penetrate any adjacent parts.
  2. Use exothermic-welded connectors; if a disconnect-type connection is required, use a bolted clamp.
- F. Grounding for Steel Building Structure: Install a driven ground rod at base of each corner column and at intermediate interior and exterior columns at distances not more than **60 feet (18 m)** apart.
- 1.
- G. Ground Ring: Install a grounding conductor, electrically connected to each building structure ground rod.
1. Install tinned-copper conductor not less than No. 4/0 AWG for bond to ground ring and for taps to building steel.
  2. Bury ground ring not less than **24 inches (600 mm)** from building's foundation.
- H. Concrete-Encased Grounding Electrode (Ufer Ground): Fabricate according to NFPA 70; use a minimum of **20 feet (6 m)** of bare copper conductor not smaller than No. 4/0 AWG.
1. If concrete foundation is less than **20 feet (6 m)** long, coil excess conductor within base of foundation.
  2. Bond grounding conductor to reinforcing steel in at least four locations in mat footing and at four spread footing locations evenly distributed throughout building. Extend grounding conductor below grade and connect to building's grounding grid or to grounding electrode external to concrete.
- I. Grounding and Bonding for Piping:
1. Metal Water Service Pipe: Install insulated copper grounding conductors, in conduit, from building's main service equipment, or grounding bus, to main metal water service entrances to building. Connect grounding conductors to main metal water service pipes; use a bolted clamp connector or bolt a lug-type connector to a pipe flange by using one of the lug bolts of the flange. Where a dielectric main water fitting is installed, connect grounding conductor on street side of fitting. Bond metal grounding conductor conduit or sleeve to conductor at each end.
  2. Water Meter Piping: Use braided-type bonding jumpers to electrically bypass water meters. Connect to pipe with a bolted connector.
  3. Bond each aboveground portion of gas piping system downstream from equipment shutoff valve.
- J. Panelboard Bonding: To comply with NEC 517.14 panelboard bonding requirements install a minimum #10 AWG copper conductor between all branch-circuit panelboard grounding terminal buses in each electrical room. The conductor may be installed in ½" EMT conduit or may be exposed where securely fastened to the walls.

**3.5 FIELD QUALITY CONTROL**

- A. Tests and Inspections:
1. After installing grounding system but before permanent electrical circuits have been energized, test for compliance with requirements.
  2. Inspect physical and mechanical condition. Verify tightness of accessible, bolted, electrical connections with a calibrated torque wrench according to manufacturer's written instructions.
  3. Test completed grounding system at each location where a maximum ground-resistance level is specified, at service disconnect enclosure grounding conductor, at ground test wells, and at individual ground rods. Make tests at ground rods before any conductors are connected.
    - a. Measure ground resistance no fewer than two full days after last trace of precipitation and without soil being moistened by any means other than natural drainage or seepage and without chemical treatment or other artificial means of reducing natural ground resistance.
    - b. Perform tests by fall-of-potential method according to IEEE 81.
  4. Prepare dimensioned Drawings locating each test well, ground rod and ground-rod assembly, and other grounding electrodes. Identify each by letter in alphabetical order, and key to the record of tests and observations. Include the number of rods driven and their depth at each location, and include observations of weather and other phenomena that may affect test results. Describe measures taken to improve test results.
- B. Grounding system will be considered defective if it does not pass tests and inspections.
- C. Prepare test and inspection reports.
- D. Report measured ground resistances that exceed 3 ohms.
- E. Excessive Ground Resistance: If resistance to ground exceeds specified values, notify Architect promptly and include recommendations to reduce ground resistance.

**END OF SECTION**

**SECTION 26 05 29**  
**HANGERS AND SUPPORTS FOR ELECTRICAL SYSTEMS**

**PART 1 - GENERAL**

**1.1 RELATED DOCUMENTS**

- A. Drawings and general provisions of the Contract, including General and Supplementary Conditions and Division 01 Specification Sections, apply to this Section.

**1.2 SUMMARY**

- A. Section Includes:
1. Hangers and supports for electrical equipment and systems.
  2. Construction requirements for concrete bases.
- B. Related Requirements:
1. Section 260548.16 "Seismic Controls for Electrical Systems" for products and installation requirements necessary for compliance with seismic criteria.

**1.3 ACTION SUBMITTALS**

- A. Product Data: For each type of product.
1. Include construction details, material descriptions, dimensions of individual components and profiles, and finishes for the following:
    - a. Hangers.
    - b. Steel slotted support systems.
    - c. Nonmetallic support systems.
    - d. Trapeze hangers.
    - e. Clamps.
    - f. Turnbuckles.
    - g. Sockets.
    - h. Eye nuts.
    - i. Saddles.
    - j. Brackets.
  2. Include rated capacities and furnished specialties and accessories.
- B. Shop Drawings: Signed and sealed by a qualified professional engineer. For fabrication and installation details for electrical hangers and support systems.
1. Trapeze hangers. Include product data for components.
  2. Steel slotted-channel systems.
  - 3.
  4. Nonmetallic slotted-channel systems.
  5. Equipment supports.
  6. Vibration Isolation Base Details: Detail fabrication, including anchorages and attachments to structure and to supported equipment. Include adjustable motor bases, rails, and frames for equipment mounting.
- C. Delegated-Design Submittal: For hangers and supports for electrical systems.
1. Include design calculations and details of trapeze hangers.



2. Include design calculations for seismic restraints.

#### **1.4 INFORMATIONAL SUBMITTALS**

- A. Coordination Drawings: Reflected ceiling plan(s) and other details, drawn to scale, on which the following items are shown and coordinated with each other, using input from installers of the items involved:
  1. Suspended ceiling components.
  2. Structural members to which hangers and supports will be attached.
  3. Size and location of initial access modules for acoustical tile.
  4. Items penetrating finished ceiling, including the following:
    - a. Lighting fixtures and lighting control.
    - b. Electrical power devices
    - c. Communications devices.
    - d. Air outlets and inlets.
    - e. Speakers.
    - f. Fire sprinklers.
    - g. Access panels.
    - h. Projectors.
    - i. Fire alarm system devices.
    - j. Nurse call system devices.
- B. Seismic Qualification Certificates: For hangers and supports for electrical equipment and systems, accessories, and components, from manufacturer.
  1. Basis for Certification: Indicate whether withstand certification is based on actual test of assembled components or on calculation.
  2. Dimensioned Outline Drawings of Equipment Unit: Identify center of gravity and locate and describe mounting and anchorage provisions.
  3. Detailed description of equipment anchorage devices on which the certification is based and their installation requirements.
- C. Welding certificates.

#### **1.5 QUALITY ASSURANCE**

- A. Welding Qualifications: Qualify procedures and personnel according to AWS D1.1/D1.1M.

### **PART 2 - PRODUCTS**

#### **2.1 PERFORMANCE REQUIREMENTS**

- A. Delegated Design: Engage a qualified professional engineer, as defined in Section 014000 "Quality Requirements," to design hanger and support system.
- B. Seismic Performance: Hangers and supports shall withstand the effects of earthquake motions determined according to ASCE/SEI 7.
  1. The term "withstand" means "the supported equipment and systems will remain in place without separation of any parts when subjected to the seismic forces specified and the system will be fully operational after the seismic event."
  2. Component Importance Factor: 1.5.

- C. Surface-Burning Characteristics: Comply with ASTM E 84; testing by a qualified testing agency. Identify products with appropriate markings of applicable testing agency.
  - 1. Flame Rating: Class 1.
  - 2. Self-extinguishing according to ASTM D 635.

## 2.2 SUPPORT, ANCHORAGE, AND ATTACHMENT COMPONENTS

- A. Steel Slotted Support Systems: Comply with MFMA-4 factory-fabricated components for field assembly.
  - 1. Material: Galvanized steel.
  - 2. Channel Width: Use 1-1/4 inches (31.75 mm) where possible and minimum 13/16 inches (20.64 mm) where necessary due to space restrictions.
  - 3. Metallic Coatings: Hot-dip galvanized after fabrication and applied according to MFMA-4.
  - 4. Channel Dimensions: Selected for applicable load criteria.
- B. Conduit and Cable Support Devices: Steel hangers, clamps, and associated fittings, designed for types and sizes of raceway or cable to be supported.
- C. Support for Conductors in Vertical Conduit: Factory-fabricated assembly consisting of threaded body and insulating wedging plug or plugs for electrical conductors in riser conduits. Plugs shall have number, size, and shape of conductor gripping pieces as required to suit individual conductors or cables supported. Body shall be made of malleable iron.
- D. Structural Steel for Fabricated Supports and Restraints: ASTM A 36/A 36M steel plates, shapes, and bars; black and galvanized.
- E. Mounting, Anchoring, and Attachment Components: Items for fastening electrical items or their supports to building surfaces include and are limited to the following:
  - 1. Powder-Actuated Fasteners: Threaded-steel stud, for use in hardened portland cement concrete, steel, or wood, with tension, shear, and pullout capacities appropriate for supported loads and building materials where used.
  - 2. Mechanical-Expansion Anchors: Insert-wedge-type, stainless steel, for use in hardened portland cement concrete, with tension, shear, and pullout capacities appropriate for supported loads and building materials where used.
  - 3. Concrete Inserts: Steel or malleable-iron, slotted support system units are similar to MSS Type 18 units and comply with MFMA-4 or MSS SP-58.
  - 4. Clamps for Attachment to Steel Structural Elements: MSS SP-58 units are suitable for attached structural element.
  - 5. Through Bolts: Structural type, hex head, and high strength. Comply with ASTM A 325.
  - 6. Hanger Rods: Threaded steel.

## 2.3 FABRICATED METAL EQUIPMENT SUPPORT ASSEMBLIES

- A. Description: Welded or bolted structural-steel shapes, shop or field fabricated to fit dimensions of supported equipment.
- B. Materials: Comply with requirements in Section 05 50 00 "Metal Fabrications" for steel shapes and plates.

**PART 3 - EXECUTION****3.1 APPLICATION**

- A. Comply with NECA 1 and NECA 101 for application of hangers and supports for electrical equipment and systems unless requirements in this Section are stricter.
- B. Comply with requirements for raceways and boxes specified in Section 260533 "Raceways and Boxes for Electrical Systems."
- C. Maximum Support Spacing and Minimum Hanger Rod Size for Raceway: Space supports for EMTs, IMCs, and RMCs as scheduled in NECA 1, where Table 1 lists maximum spacings that are less than those stated in NFPA 70. Minimum rod size shall be **3/8 inch (9 mm)** in diameter.
- D. Multiple Raceways: Install trapeze-type supports fabricated with steel slotted support system, sized so capacity can be increased by at least 25 percent in future without exceeding specified design load limits.
  - 1. Secure raceways and cables to these supports with single-bolt conduit clamps.
- E. Spring-steel clamps designed for supporting single conduits without bolts may be used for **1-1/2-inch (38-mm)** and smaller raceways serving branch circuits and communication systems above suspended ceilings and for fastening raceways to trapeze supports.

**3.2 SUPPORT INSTALLATION**

- A. Comply with NECA 1 and NECA 101 for installation requirements except as specified in this article.
- B. Raceway Support Methods: In addition to methods described in NECA 1, EMTs, IMCs, and RMCs may be supported by openings through structure members, according to NFPA 70. Only prefabricated openings in structure members may be used. Do not create openings in structure members unless directed to do so by the structural engineer of record.
- C. Cable Support Methods: Cables used for Circuits and Equipment Operating at Less Than 50 Volts and Class 1, 2 or 3 Remote-Control, Signaling and Power-Limited Circuits shall be installed in J-hooks. Where cables extend from J-hooks to equipment cables shall be supported from the structure by straps, hangers, cable ties or similar fittings designed and installed so as not to damage the cable. Do not fasten or secure cables to the raceways of the power system.
- D. Strength of Support Assemblies: Where not indicated, select sizes of components so strength will be adequate to carry present and future static loads within specified loading limits. Minimum static design load used for strength determination shall be weight of supported components plus **200 lb (90 kg)**.
- E. Mounting and Anchorage of Surface-Mounted Equipment and Components: Anchor and fasten electrical items and their supports to building structural elements by the following methods unless otherwise indicated by code:
  - 1. To Wood: Fasten with lag screws or through bolts.
  - 2. To New Concrete: Bolt to concrete inserts.
  - 3. To Masonry: Approved toggle-type bolts on hollow masonry units and expansion anchor fasteners on solid masonry units.
  - 4. To Existing Concrete: Expansion anchor fasteners.

5. Instead of expansion anchors, powder-actuated driven threaded studs provided with lock washers and nuts may be used in existing standard-weight concrete **4 inches (100 mm)** thick or greater. Do not use for anchorage to lightweight-aggregate concrete or for slabs less than **4 inches (100 mm)** thick.
  6. To Steel: Beam clamps (MSS SP-58, Type 19, 21, 23, 25, or 27), complying with MSS SP-69.
  7. To Light Steel: Sheet metal screws.
  8. Items Mounted on Hollow Walls and Nonstructural Building Surfaces: Mount cabinets, panelboards, disconnect switches, control enclosures, pull and junction boxes, transformers, and other devices on **13/16 inches (20.64 mm)** slotted-channel racks attached to substrate by means that comply with seismic-restraint strength and anchorage requirements.
- F. Drill holes for expansion anchors in concrete at locations and to depths that avoid the need for reinforcing bars.

### 3.3 INSTALLATION OF FABRICATED METAL SUPPORTS

- A. Comply with installation requirements in Section 055000 "Metal Fabrications" for site-fabricated metal supports.
- B. Cut, fit, and place miscellaneous metal supports accurately in location, alignment, and elevation to support and anchor electrical materials and equipment.
- C. Field Welding: Comply with AWS D1.1/D1.1M.

### 3.4 CONCRETE BASES

- A. Construct concrete bases of dimensions indicated but not less than **4 inches (100 mm)** larger in both directions than supported unit, and so anchors will be a minimum of 10 bolt diameters from edge of the base.
- B. Use **3000-psi (20.7-MPa)**, 28-day compressive-strength concrete. Concrete materials, reinforcement, and placement requirements are specified in Section 03 30 00 "Cast-in-Place Concrete" or Section 03 30 53 "Miscellaneous Cast-in-Place Concrete."
- C. Anchor equipment to concrete base as follows:
  1. Place and secure anchorage devices. Use supported equipment manufacturer's setting drawings, templates, diagrams, instructions, and directions furnished with items to be embedded.
  2. Install anchor bolts to elevations required for proper attachment to supported equipment.
  3. Install anchor bolts according to anchor-bolt manufacturer's written instructions.

### 3.5 PAINTING

- A. Touchup: Clean field welds and abraded areas of shop paint. Paint exposed areas immediately after erecting hangers and supports. Use same materials as used for shop painting. Comply with SSPC-PA 1 requirements for touching up field-painted surfaces.
  1. Apply paint by brush or spray to provide minimum dry film thickness of **2.0 mils (0.05 mm)**.

- B. Touchup: Comply with requirements in Section 09 91 13 "Exterior Painting", Section 099123 "Interior Painting" and Section 099600 "High-Performance Coatings" for cleaning and touchup painting of field welds, bolted connections, and abraded areas of shop paint on miscellaneous metal.
- C. Galvanized Surfaces: Clean welds, bolted connections, and abraded areas and apply galvanizing-repair paint to comply with ASTM A 780.

**END OF SECTION**

**SECTION 26 05 33**  
**RACEWAYS AND BOXES FOR ELECTRICAL SYSTEMS**

**PART 1 - GENERAL**

**1.1 RELATED DOCUMENTS**

- A. Drawings and general provisions of the Contract, including General and Supplementary Conditions and Division 01 Specification Sections, apply to this Section.

**1.2 SUMMARY**

- A. Section Includes:
  - 1. Metal conduits, tubing, and fittings.
  - 2. Nonmetal conduits, tubing, and fittings.
  - 3. Metal wireways and auxiliary gutters.
  - 4. Surface raceways.
  - 5. Boxes, enclosures, and cabinets.
  - 6. Handholes and boxes for exterior underground cabling.
- B. Related Requirements:
  - 1. Section 26 05 43 "Underground Ducts and Raceways for Electrical Systems" for exterior ductbanks, manholes, and underground utility construction.

**1.3 DEFINITIONS**

- A. ARC: Aluminum Rigid Conduit.
- B. EMT: Electrical Metallic Tubing.
- C. GRC: Galvanized rigid steel conduit.
- D. IMC: Intermediate metal conduit.
- E. RTRC: Reinforced Thermosetting Resin Conduit.

**1.4 ACTION SUBMITTALS**

- A. Product Data: For color coded EMT conduit, surface raceways, wireways and fittings, floor boxes, hinged-cover enclosures, and cabinets.
- B. LEED Submittals:
  - 1. Product Data for Credit IEQ 4.1: For solvent cements and adhesive primers, documentation including printed statement of VOC content.
  - 2. Laboratory Test Reports for Credit IEQ 4: For solvent cements and adhesive primers, documentation indicating that products comply with the testing and product requirements of the California Department of Health Services' "Standard Practice for the Testing of

## Volatile Organic Emissions from Various Sources Using Small-Scale Environmental Chambers."

- C. Shop Drawings: For custom enclosures and cabinets. Include plans, elevations, sections, and attachment details.
- D. Samples: For receptacle raceways and for each color and texture specified, 12 inches (300 mm) long.

**1.5 INFORMATIONAL SUBMITTALS**

- A. Coordination Drawings: Conduit routing plans, drawn to scale, on which the following items are shown and coordinated with each other, using input from installers of items involved:
  - 1. Structural members in paths of conduit groups with common supports.
  - 2. HVAC and plumbing items and architectural features in paths of conduit groups with common supports.
- B. Qualification Data: For professional engineer.
- C. Seismic Qualification Certificates: For enclosures, cabinets, and conduit racks and their mounting provisions, including those for internal components, from manufacturer.
  - 1. Basis for Certification: Indicate whether withstand certification is based on actual test of assembled components or on calculation.
  - 2. Dimensioned Outline Drawings of Equipment Unit: Identify center of gravity and locate and describe mounting and anchorage provisions.
  - 3. Detailed description of equipment anchorage devices on which the certification is based and their installation requirements.
  - 4. Detailed description of conduit support devices and interconnections on which the certification is based and their installation requirements.
- D. Source quality-control reports.

**PART 2 - PRODUCTS****2.1 METAL CONDUITS, TUBING, AND FITTINGS**

- A. Listing and Labeling: Metal conduits, tubing, and fittings shall be listed and labeled as defined in NFPA 70, by a qualified testing agency, and marked for intended location and application.
- B. GRC: Comply with ANSI C80.1 and UL 6.
- C. ARC: Comply with ANSI C80.5 and UL 6A.
- D. IMC: Comply with ANSI C80.6 and UL 1242.
- E. EMT: Comply with ANSI C80.3 and UL 797. Factory applied color finish available in black, orange, green, purple, red, yellow, blue, and white. Refer to Specification Section 26 05 53 "Identification for Electrical Systems" for color coding of raceways.
- F. FMC: Comply with UL 1; zinc-coated steel.
- G. LFMC: Flexible steel conduit with PVC jacket and complying with UL 360.

- H. Fittings for Metal Conduit: Comply with NEMA FB 1 and UL 514B.
  - 1. Conduit Fittings for Hazardous (Classified) Locations: Comply with UL 886 and NFPA 70.
  - 2. Fittings for EMT:
    - a. Material: Steel.
    - b. Type: Set screw or compression.
  - 3. Expansion Fittings: PVC or steel to match conduit type, complying with UL 651, rated for environmental conditions where installed, and including flexible external bonding jumper.
- I. Joint Compound for IMC, GRC, or ARC: Approved, as defined in NFPA 70, by authorities having jurisdiction for use in conduit assemblies, and compounded for use to lubricate and protect threaded conduit joints from corrosion and to enhance their conductivity.

## **2.2 NONMETALLIC CONDUITS, TUBING, AND FITTINGS**

- A. Listing and Labeling: Nonmetallic conduits, tubing, and fittings shall be listed and labeled as defined in NFPA 70, by a qualified testing agency, and marked for intended location and application.
- B. RNC: Type EPC-40-PVC, complying with NEMA TC 2 and UL 651 unless otherwise indicated.
- C. Continuous HDPE: Comply with UL 651B.
- D. RTRC: Comply with UL 1684A and NEMA TC 14.
- E. Fittings for RNC: Comply with NEMA TC 3; match to conduit or tubing type and material.
- F. Solvent cements and adhesive primers shall have a VOC content of 510 and 550 g/L or less, respectively, when calculated according to 40 CFR 59, Subpart D (EPA Method 24).
- G. Solvent cements and adhesive primers shall comply with the testing and product requirements of the California Department of Health Services' "Standard Practice for the Testing of Volatile Organic Emissions from Various Sources Using Small-Scale Environmental Chambers."

## **2.3 METAL WIREWAYS AND AUXILIARY GUTTERS**

- A. Description: Sheet metal, complying with UL 870 and NEMA 250, Type 1 unless otherwise indicated, and sized according to NFPA 70.
  - 1. Metal wireways installed outdoors shall be listed and labeled as defined in NFPA 70, by a qualified testing agency, and marked for intended location and application.
- B. Fittings and Accessories: Include covers, couplings, offsets, elbows, expansion joints, adapters, hold-down straps, end caps, and other fittings to match and mate with wireways as required for complete system.
- C. Wireway Covers: Hinged type unless otherwise indicated.
- D. Finish: Manufacturer's standard enamel finish.



**2.4 RECEPTACLE RACEWAYS**

- A. Listing and Labeling: Receptacle raceways shall be listed and labeled as defined in NFPA 70, by a qualified testing agency, and marked for intended location and application.
- B. Surface Metal Raceways: Aluminum with snap-on covers complying with UL. Clear anodized finish.
  - 1. Raceways for receptacles only: Wiremold AL3300 series.
  - 2. Raceways for applications where both receptacles and data devices are installed in the raceway and at all laboratory locations: Wiremold ALA4800 series two-channel and dual-cover. Satin anodized finish.
  - 3. Provide duplex receptacles at 12 inches on center in all receptacle raceways. Provide GFCI receptacles as noted on drawings.

**2.5 BOXES, ENCLOSURES, AND CABINETS**

- A. General Requirements for Boxes, Enclosures, and Cabinets: Boxes, enclosures, and cabinets installed in wet locations shall be listed for use in wet locations.
- B. Sheet Metal Outlet and Device Boxes: Comply with NEMA OS 1 and UL 514A.
- C. Cast-Metal Outlet and Device Boxes: Comply with NEMA FB 1, aluminum, Type FD, with gasketed cover.
- D. Nonmetallic Outlet and Device Boxes: Comply with NEMA OS 2 and UL 514C.
- E. Floor Boxes and Poke-Through Devices: Refer to Specification Section 26 27 26 "Wiring Devices" for floor boxes and poke-through devices
- F. Luminaire Outlet Boxes: Nonadjustable, designed for attachment of luminaire weighing **50 lb (23 kg)**. Outlet boxes designed for attachment of luminaires weighing more than **50 lb (23 kg)** shall be listed and marked for the maximum allowable weight.
- G. Small Sheet Metal Pull and Junction Boxes: NEMA OS 1.
- H. Cast-Metal Access, Pull, and Junction Boxes: Comply with NEMA FB 1 and UL 1773, cast aluminum with gasketed cover.
- I. Box extensions used to accommodate new building finishes shall be of same material as recessed box.
- J. Device Box Dimensions:
  - 1. **Wiring Devices other than data or communications devices: Minimum 4 inches square by 2-1/8 inches deep** with switch ring as required for the device configuration and wall or ceiling surface. Where light switches are indicated at a common location provide multi-gang boxes to accommodate the quantity and type of switches indicated. Where deeper boxes are required provide masonry type boxes which do not require a separate switch ring.
  - 2. Data and communications devices: Minimum 4-11/16 inches square by 3 inches deep with single-gang 5/8 inch deep (or deeper if wall or ceiling finish is deeper) ring.
- K. Pull boxes behind monitors: Minimum 6 inches square by 3-1/2 inches deep with two-gang ring.
- L. Gangable boxes are prohibited.

- M. Partitions: Provide partitions to separate emergency system conductors from conductors or other systems, where voltage between adjacent switches exceeds 300 volts and where switches controlling Low Voltage Controllers for interface to Nurse Call systems are installed in common boxes with line voltage switches.
- N. Hinged-Cover Enclosures: Comply with UL 50 and NEMA 250.
  - 1. Indoor: Type 1 with continuous-hinge cover with flush latch unless otherwise indicated. Steel, finished inside and out with manufacturer's standard enamel.
  - 2. Outdoor: Type 4X with continuous-hinge cover with flush latch unless otherwise indicated. 304 stainless steel with smooth brushed finish.
  - 3. Interior Panels: Steel; all sides finished with manufacturer's standard enamel. Provide interior panels when there are control devices or power blocks located inside the enclosure.
- O. Handholes and Boxes for Exterior Underground Wiring: Refer to Specification Section 26 05 43 "Underground Ducts and Raceways for Electrical Systems".

## 2.6 PUTTY PADS

- A. Moldable intumescent wall opening-protective pads designed for application to the back of electrical outlet boxes prior to installation of the wall finish to provide up to 2-hour fire barrier ratings and minimum Sound Transmission Class (STC) of 52 when tested in an STC-53 rated wall assembly or 59 according to ASTM E90-97.
- B. Manufacturers: Subject to compliance with requirements, provide products by one of the following:
  - 1. 3M Company.
  - 2. Hilti

## PART 3 - EXECUTION

### 3.1 RACEWAY APPLICATION

- A. Outdoors: Apply raceway products as specified below unless otherwise indicated:
  - 1. Exposed Conduit: GRC or IMC.
  - 2. Concealed Conduit, Aboveground: EMT.
  - 3. Underground Conduit for branch circuits: RNC, Type EPC-40-PVC, direct buried.
  - 4. Underground Conduit for feeders: Refer to Specification Section 26 05 43 "Underground Ducts and Raceways for Electrical Systems".
  - 5. Raceways Embedded in slabs or composite steel and concrete decks are prohibited.
  - 6. Connection to Vibrating Equipment (Including Transformers and Hydraulic, Pneumatic, Electric Solenoid, or Motor-Driven Equipment): LFMC.
  - 7. Boxes and Enclosures, Aboveground: NEMA 250, Type 4X, 304 stainless steel.
- B. Indoors: Apply raceway products as specified below unless otherwise indicated:
  - 1. Exposed, Not Subject to Physical Damage: EMT.
  - 2. Exposed, Not Subject to Severe Physical Damage: EMT.
  - 3. Exposed and Subject to Severe Physical Damage: GRC or IMC. Raceway locations include the following:
    - a. Loading dock.
    - b. Corridors used for traffic of mechanized carts, forklifts, and pallet-handling units.
    - c. Mechanical rooms below 8 feet.
    - d. Gymnasiums.

4. Concealed in Ceilings and Interior Walls and Partitions: EMT.
  5. Feeder Raceways under Slabs: RNC, Type EPC-40-PVC encased in not less than 2 inches of 3000 psi concrete. Change from RNC, Type EPC-40-PVC to GRC or IMC before rising above floor.
  6. Branch Circuit Raceways under Slabs: Refer to Specifications Section 26 05 19 "Low-Voltage Electrical Power Conductors and Cables" for allowable application of under slab raceways. RNC, Type EPC-40-PVC direct buried. Change from RNC, Type EPC-40-PVC to GRC or IMC before rising above floor.
  7. Raceways Embedded in slabs or composite steel and concrete decks are prohibited.
  8. Connection to Vibrating Equipment (Including Transformers and Hydraulic, Pneumatic, Electric Solenoid, or Motor-Driven Equipment): FMC, except use LFMC in damp or wet locations.
  9. Damp or Wet Locations: GRC or IMC.
  10. Boxes and Enclosures: NEMA 250, Type 1, except use NEMA 250, Type 4X, 304 stainless steel in kitchens and damp or wet locations.
  - 11.
- C. Minimum Raceway Size: **3/4-inch (21-mm)** trade size.
- D. Raceway Fittings: Compatible with raceways and suitable for use and location.
1. Rigid and Intermediate Steel Conduit: Use threaded rigid steel conduit fittings unless otherwise indicated. Comply with NEMA FB 2.10.
  2. EMT: Use setscrew or compression, steel fittings. Comply with NEMA FB 2.10.
  3. Flexible Conduit: Use only fittings listed for use with flexible conduit. Comply with NEMA FB 2.20.
- E. Install nonferrous conduit or tubing for circuits operating above 60 Hz. Where aluminum raceways are installed for such circuits and pass through concrete, install in nonmetallic sleeve.
- F. Do not install aluminum conduits, boxes, or fittings in contact with concrete or earth.
- G. Install surface raceways only where indicated on Drawings.

### 3.2 INSTALLATION

- A. Comply with NECA 1 and NECA 101 for installation requirements except where requirements on Drawings or in this article are stricter. Comply with NECA 102 for aluminum conduits. Comply with NFPA 70 limitations for types of raceways allowed in specific occupancies and number of floors.
- B. Separation of Life Safety and Critical Branch Wiring: Comply with NFPA 70 Article 517.
- C. Keep raceways at least **6 inches (150 mm)** away from parallel runs of flues and steam or hot-water pipes. Install horizontal raceway runs above water and steam piping.
- D. Complete raceway installation before starting conductor installation.
- E. Comply with requirements in Section 26 05 29 "Hangers and Supports for Electrical Systems" for hangers and supports.
- F. Arrange stub-ups so curved portions of bends are not visible above finished slab except where concealed in chases.

- G. Install no more than the equivalent of three 90-degree bends in any conduit run except for control wiring conduits, for which fewer bends are allowed. Support within **12 inches (300 mm)** of changes in direction.
- H. Conceal conduit and EMT within finished walls, ceilings, and floors unless otherwise indicated. Install conduits parallel or perpendicular to building lines.
- I. Support conduit within **12 inches (300 mm)** of enclosures to which attached.
- J. Raceways Embedded in Slabs are prohibited.
- K. Stub-ups to Above Recessed Ceilings:
  - 1. Use EMT, IMC, or RMC for raceways.
  - 2. Use a conduit bushing or insulated fitting to terminate stub-ups not terminated in hubs or in an enclosure.
- L. Threaded Conduit Joints, Exposed to Wet, Damp, Corrosive, or Outdoor Conditions: Apply listed compound to threads of raceway and fittings before making up joints. Follow compound manufacturer's written instructions.
- M. Coat field-cut threads on PVC-coated raceway with a corrosion-preventing conductive compound prior to assembly.
- N. Raceway Terminations at Locations Subject to Moisture or Vibration: Use insulating bushings to protect conductors including conductors smaller than No. 4 AWG.
- O. Terminate threaded conduits into threaded hubs or with locknuts on inside and outside of boxes or cabinets. Install bushings on conduits up to **1-1/4-inch (35mm)** trade size and insulated throat metal bushings on **1-1/2-inch (41-mm)** trade size and larger conduits terminated with locknuts. Install insulated throat metal grounding bushings on service conduits.
- P. Install raceways square to the enclosure and terminate at enclosures with locknuts. Install locknuts hand tight plus 1/4 turn more.
- Q. Do not rely on locknuts to penetrate nonconductive coatings on enclosures. Remove coatings in the locknut area prior to assembling conduit to enclosure to assure a continuous ground path.
- R. Cut conduit perpendicular to the length. For conduits **2-inch (53-mm)** trade size and larger, use roll cutter or a guide to make cut straight and perpendicular to the length.
- S. Install pull wires in empty raceways. Use polypropylene or monofilament plastic line with not less than **200-lb (90-kg)** tensile strength. Leave at least **12 inches (300 mm)** of slack at each end of pull wire. Cap underground raceways designated as spare above grade alongside raceways in use.
- T. Surface Raceways:
  - 1. Install surface raceway with a minimum **2-inch (50-mm)** radius control at bend points.
  - 2. Secure surface raceway with screws or other anchor-type devices at intervals not exceeding **48 inches (1200 mm)** and with no less than two supports per straight raceway section. Support surface raceway according to manufacturer's written instructions. Tape and glue are not acceptable support methods.
- U. Install raceway sealing fittings at accessible locations according to NFPA 70 and fill them with listed sealing compound. For concealed raceways, install each fitting in a flush steel box with a blank cover plate having a finish similar to that of adjacent plates or surfaces. Install raceway sealing fittings according to NFPA 70.

- V. Install devices to seal raceway interiors at accessible locations. Locate seals so no fittings or boxes are between the seal and the following changes of environments. Seal the interior of all raceways at the following points:
1. Where conduits pass from warm to cold locations, such as boundaries of refrigerated spaces.
  2. Where an underground service raceway enters a building or structure.
  3. Where otherwise required by NFPA 70.
- W. Comply with manufacturer's written instructions for solvent welding RNC and fittings.
- X. Expansion(Seismic)-Joint Fittings:
1. Install flexible metal conduit at all locations where conduits cross building or structure expansion joints. Allow for minimum 4 inches deflection in all directions or greater if expansion joint exceeds 4 inches. Provide droop in flexible conduit to accommodate movement. Do not loop the flexible conduit. When calculating total bend degrees in conduit runs with expansion fittings use minimum 60 degrees for each expansion-joint fitting
  2. Install each expansion-joint fitting with position, mounting, and piston setting selected according to manufacturer's written instructions for conditions at specific location at time of installation. Install conduit supports to allow for expansion movement.
- Y. Flexible Conduit Connections: Comply with NEMA RV 3. Use a maximum of **72 inches (1830 mm)** of flexible conduit for recessed and semi-recessed luminaires, equipment subject to vibration, noise transmission, or movement; and for transformers and motors.
1. Use LFMC in damp or wet locations.
- Z. Mount boxes at heights indicated on Drawings. If mounting heights of boxes are not individually indicated, give priority to ADA requirements. Install boxes with height measured to center of box unless otherwise indicated.
- AA. Recessed Boxes in Masonry Walls: Saw-cut opening for box in center of cell of masonry block, and install box flush with surface of wall. Prepare block surfaces to provide a flat surface for a raintight connection between box and cover plate or supported equipment and box.
- BB. Horizontally separate boxes mounted on opposite sides of walls so they are not in the same vertical channel.
- CC. Locate boxes so that cover or plate will not span different building finishes.
- DD. Support boxes of three gangs or more from more than one side by spanning two framing members or mounting on brackets specifically designed for the purpose.
- EE. Fasten junction and pull boxes to or support from building structure. Do not support boxes by conduits.
- FF. Set metal floor boxes level and flush with finished floor surface.
- GG. Set nonmetallic floor boxes level. Trim after installation to fit flush with finished floor surface.
- 3.3 SLEEVE AND SLEEVE-SEAL INSTALLATION FOR ELECTRICAL PENETRATIONS**
- A. Install sleeves and sleeve seals at penetrations of exterior floor and wall assemblies. Comply with requirements in Section 26 05 44 "Sleeves and Sleeve Seals for Electrical Raceways and Cabling."

**3.4 FIRESTOPPING AND SOUND TRANSMISSION MITIGATION**

- A. Install firestopping at penetrations of fire-rated floor and wall assemblies. Comply with requirements in Section 07 84 13 "Penetration Firestopping."
- B. Install putty pads with acoustical and firestopping capabilities on all boxes that are installed in wall or partition cavities and in gypsum board ceilings.

**3.5 PROTECTION**

- A. Protect coatings, finishes, and cabinets from damage and deterioration.
  - 1. Repair damage to galvanized finishes with zinc-rich paint recommended by manufacturer.
  - 2. Repair damage to PVC coatings or paint finishes with matching touchup coating recommended by manufacturer.

**END OF SECTION**

**SECTION 26 05 44****SLEEVES AND SLEEVE SEALS FOR ELECTRICAL RACEWAYS AND CABLING****PART 1 - GENERAL****1.1 RELATED DOCUMENTS**

- A. Drawings and general provisions of the Contract, including General and Supplementary Conditions and Division 01 Specification Sections, apply to this Section.

**1.2 SUMMARY**

- A. Section Includes:
  - 1. Sleeves for raceway and cable penetration of non-fire-rated construction walls and floors.
  - 2. Sleeve-seal systems.
  - 3. Sleeve-seal fittings.
  - 4. Grout.
  - 5. Silicone sealants.
- B. Related Requirements:
  - 1. Section 07 84 13 "Penetration Firestopping" for penetration firestopping installed in fire-resistance-rated walls, horizontal assemblies, and smoke barriers, with and without penetrating items.

**1.3 ACTION SUBMITTALS**

- A. Product Data: For each type of product.
- B. LEED Submittals:
  - 1. Product Data for Credit EQ 4.1: For sealants, documentation including printed statement of VOC content.
  - 2. Laboratory Test Reports for Credit EQ 4: For sealants, documentation indicating that products comply with the testing and product requirements of the California Department of Health Services' "Standard Practice for the Testing of Volatile Organic Emissions from Various Sources Using Small-Scale Environmental Chambers."

**PART 2 - PRODUCTS****2.1 SLEEVES**

- A. Wall Sleeves:
  - 1. Steel Pipe Sleeves: ASTM A 53/A 53M, Type E, Grade B, Schedule 40, zinc coated, plain ends.
  - 2. Cast-Iron Pipe Sleeves: Cast or fabricated "wall pipe," equivalent to ductile-iron pressure pipe, with plain ends and integral waterstop unless otherwise indicated.

- B. Sleeves for Conduits Penetrating Non-Fire-Rated Gypsum Board Assemblies: Galvanized-steel sheet; **0.0239-inch (0.6-mm)** minimum thickness; round tube closed with welded longitudinal joint, with tabs for screw-fastening the sleeve to the board.
- C. PVC-Pipe Sleeves: ASTM D 1785, Schedule 40.
- D. Molded-PVC Sleeves: With nailing flange for attaching to wooden forms.
- E. Molded-PE or -PP Sleeves: Removable, tapered-cup shaped, and smooth outer surface with nailing flange for attaching to wooden forms.
- F. Sleeves for Rectangular Openings:
  - 1. Material: Galvanized sheet steel.
  - 2. Minimum Metal Thickness:
    - a. For sleeve cross-section rectangle perimeter less than **50 inches (1270 mm)** and with no side larger than **16 inches (400 mm)**, thickness shall be **0.052 inch (1.3 mm)**.
    - b. For sleeve cross-section rectangle perimeter **50 inches (1270 mm)** or more and one or more sides larger than **16 inches (400 mm)**, thickness shall be **0.138 inch (3.5 mm)**.

## 2.2 SLEEVE-SEAL SYSTEMS

- A. Description: Modular sealing device, designed for field assembly, to fill annular space between sleeve and raceway or cable.
  - 1. Sealing Elements: EPDM rubber interlocking links shaped to fit surface of pipe. Include type and number required for pipe material and size of pipe.
  - 2. Pressure Plates: Stainless steel.
  - 3. Connecting Bolts and Nuts: Stainless steel of length required to secure pressure plates to sealing elements.

## 2.3 SLEEVE-SEAL FITTINGS

- A. Description: Manufactured plastic, sleeve-type, waterstop assembly made for embedding in concrete slab or wall. Unit shall have plastic or rubber waterstop collar with center opening to match piping OD.

## 2.4 GROUT

- A. Description: Nonshrink; recommended for interior and exterior sealing openings in non-fire-rated walls or floors.
- B. Standard: ASTM C 1107/C 1107M, Grade B, post-hardening and volume-adjusting, dry, hydraulic-cement grout.
- C. Design Mix: **5000-psi (34.5-MPa)**, 28-day compressive strength.
- D. Packaging: Premixed and factory packaged.



**2.5 SILICONE SEALANTS**

- A. Silicone Sealants: Single-component, silicone-based, neutral-curing elastomeric sealants of grade indicated below.
1. Grade: Pourable (self-leveling) formulation for openings in floors and other horizontal surfaces that are not fire rated.
  2. Sealant shall have VOC content of 50 g/L or less when calculated according to 40 CFR 59, Subpart D (EPA Method 24).
  3. Sealant shall comply with the testing and product requirements of the California Department of Health Services' "Standard Practice for the Testing of Volatile Organic Emissions from Various Sources Using Small-Scale Environmental Chambers."
- B. Silicone Foams: Multicomponent, silicone-based liquid elastomers that, when mixed, expand and cure in place to produce a flexible, nonshrinking foam.

**PART 3 - EXECUTION****3.1 SLEEVE INSTALLATION FOR NON-FIRE-RATED ELECTRICAL PENETRATIONS**

- A. Comply with NECA 1.
- B. Comply with NEMA VE 2 for cable tray and cable penetrations.
- C. Sleeves for Conduits Penetrating Above-Grade Non-Fire-Rated Concrete and Masonry-Unit Floors and Walls:
1. Interior Penetrations of Non-Fire-Rated Walls and Floors:
    - a. Seal annular space between sleeve and raceway or cable, using joint sealant appropriate for size, depth, and location of joint. Comply with requirements in Section 079200 "Joint Sealants."
    - b. Seal space outside of sleeves with mortar or grout. Pack sealing material solidly between sleeve and wall so no voids remain. Tool exposed surfaces smooth; protect material while curing.
  2. Use pipe sleeves unless penetration arrangement requires rectangular sleeved opening.
  3. Size pipe sleeves to provide **1/4-inch (6.4-mm)** annular clear space between sleeve and raceway or cable unless sleeve seal is to be installed or unless seismic criteria require different clearance.
  4. Install sleeves for wall penetrations unless core-drilled holes or formed openings are used. Install sleeves during erection of walls. Cut sleeves to length for mounting flush with both surfaces of walls. Deburr after cutting.
  5. Install sleeves for floor penetrations. Extend sleeves installed in floors 4 inches above finished floor level. Install sleeves during erection of floors.
- D. Sleeves for Conduits Penetrating Non-Fire-Rated Gypsum Board Assemblies:
1. Use circular metal sleeves unless penetration arrangement requires rectangular sleeved opening.
  2. Seal space outside of sleeves with approved joint compound for gypsum board assemblies.
- E. Roof-Penetration Sleeves: Seal penetration of individual raceways and cables with flexible boot-type flashing units applied in coordination with roofing work.
- F. Aboveground, Exterior-Wall Penetrations: Seal penetrations using cast-iron pipe sleeves and mechanical sleeve seals. Select sleeve size to allow for **1-inch (25-mm)** annular clear space between pipe and sleeve for installing mechanical sleeve seals.

- G. Underground, Exterior-Wall and Floor Penetrations: Install cast-iron pipe sleeves. Size sleeves to allow for **1-inch (25-mm)** annular clear space between raceway or cable and sleeve for installing sleeve-seal system.

### **3.2 SLEEVE-SEAL-SYSTEM INSTALLATION**

- A. Install sleeve-seal systems in sleeves in exterior concrete walls and slabs-on-grade at raceway entries into building.
- B. Install type and number of sealing elements recommended by manufacturer for raceway or cable material and size. Position raceway or cable in center of sleeve. Assemble mechanical sleeve seals and install in annular space between raceway or cable and sleeve. Tighten bolts against pressure plates that cause sealing elements to expand and make watertight seal.

### **3.3 SLEEVE-SEAL-FITTING INSTALLATION**

- A. Install sleeve-seal fittings in new walls and slabs as they are constructed.
- B. Assemble fitting components of length to be flush with both surfaces of concrete slabs and walls. Position waterstop flange to be centered in concrete slab or wall.
- C. Secure nailing flanges to concrete forms.
- D. Using grout, seal the space around outside of sleeve-seal fittings.

**END OF SECTION**

**SECTION 26 05 53**  
**IDENTIFICATION FOR ELECTRICAL SYSTEMS**

**PART 1 - GENERAL**

**1.1 RELATED DOCUMENTS**

- A. Drawings and general provisions of the Contract, including General and Supplementary Conditions and Division 01 Specification Sections, apply to this Section.

**1.2 SUMMARY**

- A. Section Includes:
  - 1. Identification for raceways.
  - 2. Identification of power and control cables.
  - 3. Identification for conductors.
  - 4. Underground-line warning tape.
  - 5. Warning labels and signs.
  - 6. Instruction signs.
  - 7. Equipment identification labels, including arc-flash warning labels.
  - 8. Miscellaneous identification products.

**1.3 ACTION SUBMITTALS**

- A. Product Data: For each type of product.
  - 1. Include construction details, material descriptions, dimensions of individual components and profiles, and finishes for electrical identification products.
- B. Samples: For each type of label and sign to illustrate composition, size, colors, lettering style, mounting provisions, and graphic features of identification products.
- C. Identification Schedule: For each piece of electrical equipment and electrical system components to be an index of nomenclature for electrical equipment and system components used in identification signs and labels. Use same designations indicated on Drawings.
- D. Delegated-Design Submittal: For arc-flash hazard study.

**PART 2 - PRODUCTS**

**2.1 PERFORMANCE REQUIREMENTS**

- A. Comply with ASME A13.1 and IEEE C2.
- B. Comply with NFPA 70.

- C. Comply with 29 CFR 1910.144 and 29 CFR 1910.145.
- D. Comply with ANSI Z535.4 for safety signs and labels.
- E. Adhesive-attached labeling materials, including label stocks, laminating adhesives, and inks used by label printers, shall comply with UL 969.
- F. Thermal Movements: Allow for thermal movements from ambient and surface temperature changes.
  - 1. Temperature Change: 120 deg F (67 deg C), ambient; 180 deg F (100 deg C), material surfaces.

## 2.2 COLOR AND LEGEND REQUIREMENTS

- A. Use the following color code for all electrical equipment and junction boxes that are specified to be labeled:
  - 1. Standby Power Circuits: Black letters on red field.
  - 2. Life Safety Branch Circuits: White letters on orange Field
  - 3. Critical Branch Circuits: White letters on red Field
  - 4. Equipment System Circuits: White letters on green field.
  - 5. Normal Power Circuits: White letters on black field.
  - 6. Uninterruptible Power Supply (UPS):
    - a. UPS-A: Blue letters on a grey field.
    - b. UPS-B: Red letters on a grey field.
  - 7. Fire Alarm: Red letters on white field.
  - 8. Communications: White letters on blue field.
- B. Warning labels and signs shall include, but are not limited to, the following legends:
  - 1. Multiple Power Source Warning: "DANGER - ELECTRICAL SHOCK HAZARD - EQUIPMENT HAS MULTIPLE POWER SOURCES."
  - 2. Workspace Clearance Warning: "WARNING - OSHA REGULATION - AREA IN FRONT OF ELECTRICAL EQUIPMENT MUST BE KEPT CLEAR FOR XX INCHES" where XX is replaced by the clearance requirements of NFPA 70.
- C. Use the following color code for all electrical raceways that are specified to be labeled:
  - 1. Color Coding for Raceways:
    - a. Standby Power: Black
    - b. Life Safety Branch: Yellow
    - c. Critical Branch: Orange
    - d. Equipment Branch: Green
    - e. UPS: White
    - f. Fire alarm: Red
    - g. Communications: Blue
    - h. Access Control: Purple
  - 2. Vinyl Labels for Raceways Carrying Circuits at 600 V or Less: where voltage, system type, or other written information is required, black lettering on orange background.

## 2.3 LABELS

- A. Vinyl Labels for Raceways Carrying Circuits at 600 V or Less: printed, flexible labels laminated with a clear, weather- and chemical-resistant coating and matching wraparound clear adhesive tape for securing label ends.
- B. Indoor Equipment Labels: Self-adhesive, engraved, laminated acrylic or melamine plastic label. Unless otherwise indicated, provide a single line of text with **1/2-inch- (13-mm-)** high letters on **1-1/2-inch- (38-mm-)** high label; where two lines of text are required, use labels **2 inches (50 mm)** high. Color coded as indicated in Color and Legend Requirements.
- C. Outdoor Equipment: Engraved, laminated acrylic or melamine plastic label, punched or drilled for mechanical fasteners. Unless otherwise indicated, provide a single line of text with **1/2-inch- (13-mm-)** high letters on **1-1/2-inch- (38-mm-)** high label; where two lines of text are required, use labels **2 inches (50 mm)** high. Color coded as indicated in Color and Legend Requirements.

## 2.4 BANDS AND TUBES:

- A. Snap-Around, Color-Coding Bands for Cables: Slit, pretensioned, flexible, solid-colored acrylic sleeves, **2 inches (50 mm)** long, with diameters sized to suit diameters of raceways or cables they identify, and that stay in place by gripping action.

## 2.5 TAPES AND STENCILS:

- A. Marker Tapes: Vinyl or vinyl-cloth, self-adhesive wraparound type, with circuit identification legend machine printed by thermal transfer or equivalent process.

## 2.6 SIGNS

- A. Laminated Acrylic or Melamine Plastic Signs:
  - 1. Engraved legend.
  - 2. Thickness:
    - a. For signs up to **20 sq. inches (129 sq. cm)**, minimum **1/16-inch- (1.6-mm-)**.
    - b. For signs larger than **20 sq. inches (129 sq. cm)**, **1/8 inch (3.2 mm)** thick.
    - c. Engraved legend with white letters on a dark grey background.
    - d. Punched or drilled for mechanical fasteners.
    - e. Framed with mitered acrylic molding and arranged for attachment at applicable equipment.

## 2.7 MISCELLANEOUS IDENTIFICATION PRODUCTS

- A. Paint: Comply with requirements in painting Sections for paint materials and application requirements. Retain paint system applicable for surface material and location (exterior or interior).
- B. Fasteners for Labels and Signs: Self-tapping, stainless-steel screws or stainless-steel machine screws with nuts and flat and lock washers.

## **PART 3 - EXECUTION**

### **3.1 PREPARATION**

- A. Self-Adhesive Identification Products: Before applying electrical identification products, clean substrates of substances that could impair bond, using materials and methods recommended by manufacturer of identification product.

### **3.2 INSTALLATION**

- A. Verify and coordinate identification names, abbreviations, colors, and other features with requirements in other Sections requiring identification applications, Drawings, Shop Drawings, manufacturer's wiring diagrams, and operation and maintenance manual. Use consistent designations throughout Project.
- B. Install identifying devices before installing acoustical ceilings and similar concealment.
- C. Verify identity of each item before installing identification products.
- D. Install identification materials and devices at locations for most convenient viewing without interference with operation and maintenance of equipment. Install access doors or panels to provide view of identifying devices.
- E. Apply identification devices to surfaces that require finish after completing finish work.
- F. Attach signs and plastic labels that are not self-adhesive type with mechanical fasteners appropriate to the location and substrate.
- G. Attach plastic raceway and cable labels that are not self-adhesive type with clear vinyl tape, with adhesive appropriate to the location and substrate.
- H. System Identification for Feeder Raceways: Each color-coding band shall completely encircle cable or conduit. Place adjacent bands of two-color markings in contact, side by side. Locate bands at changes in direction, at penetrations of walls and floors, at **50-foot (15-m)** maximum intervals in straight runs, and at **25-foot (7.6-m)** maximum intervals in congested areas.
- I. Fire Alarm: Provide raceway with factory applied finish or paint conduit in field.
- J. During backfilling of trenches, install continuous underground-line warning tape directly above cable or raceway at **6 to 8 inches (150 to 200 mm)** below finished grade. Use multiple tapes where width of multiple lines installed in a common trench or concrete envelope exceeds **16 inches (400 mm)** overall.

### **3.3 IDENTIFICATION SCHEDULE**

- A. Switchboards and Panelboards: Include Identification per the One-Line Diagrams and the Source Location, including the circuit number.
- B. Disconnect Switches, Enclosed Circuits Breakers and Motor Controllers. Identify the equipment that is controlled and the Source, including the circuit number.

- C. Accessible Raceways, including above accessible ceilings, for all Feeder Circuits and for Branch Circuit rated more than 30A: Identify with self-adhesive tape or vinyl label. Install labels at **30-foot (10-m)** maximum intervals.
- D. Accessible Raceways and Cables, including above accessible ceilings, within Buildings: Identify the covers of each junction and pull box of the following systems with self-adhesive vinyl labels indicating the wiring system and system voltage. Conform to system color legend/schedule.
1. Standby Power
  2. Life Safety Branch
  3. Critical Branch
  4. Equipment System
  5. Normal Power
  6. UPS
  7. Fire Alarm
  8. Communications
  9. Access Control
- E. Power-Circuit Conductor Identification, 600 V or Less: For conductors in vaults, pull and junction boxes, manholes, and handholes, use color-coding conductor tape to identify the phase.
1. Grounded Systems: Color-Coding for Phase-, Neutral- and Voltage-Level Identification: Use colors listed below for feeder and branch-circuit conductors.
    - a. Colors for 208/120-V Circuits:
      - 1) Phase A: Black.
      - 2) Phase B: Red.
      - 3) Phase C: Blue.
      - 4) Feeder Neutral: White
      - 5) Branch Circuit Neutral: White with colored stripe matching the color of the phase circuit that is paired with the neutral.
    - b. Colors for 480/277-V Circuits:
      - 1) Phase A: Brown.
      - 2) Phase B: Orange.
      - 3) Phase C: Yellow.
      - 4) Feeder Neutral: Grey
      - 5) Branch Circuit Neutral: Grey with colored stripe matching the color of the phase circuit that is paired with the neutral.
  2. Isolated Power Systems: Color-Coding for Circuit Identification: Use colors listed below for Isolated Power conductors.
    - a. Isolated Conductor No.1: Orange with at least one distinctive colored stripe other than white, green, or grey along the entire length of the conductor.
    - b. Isolated Conductor No. 2: Brown with at least one distinctive colored stripe other than white, green, or grey along the entire length of the conductor.
  3. Color shall be factory applied or field applied for sizes larger than No. 8 AWG if authorities having jurisdiction permit.
    - a. Field-Applied, Color-Coding Conductor Tape: Apply in half-lapped turns for a minimum distance of **6 inches (150 mm)** from terminal points and in boxes where splices or taps are made. Apply last two turns of tape with no tension to prevent possible unwinding. Locate bands to avoid obscuring factory cable markings.
  4. Provide a sign at each panelboard identifying the color coding scheme.
- F. Install instructional sign, including the color code for grounded and ungrounded conductors using adhesive-film-type labels.

- G. Control-Circuit Conductor Identification: For conductors and cables in pull and junction boxes, manholes, and handholes, use self-adhesive vinyl labels with the conductor or cable designation, origin, and destination.
- H. Control-Circuit Conductor Termination Identification: For identification at terminations, provide self-adhesive vinyl labels with the conductor designation.
- I. Conductors To Be Extended in the Future: Attach write-on tags to conductors and list source.
- J. Auxiliary Electrical Systems Conductor Identification: Identify field-installed alarm, control, and signal connections.
  - 1. Identify conductors, cables, and terminals in enclosures and at junctions, terminals, and pull points. Identify by system and circuit designation.
  - 2. Use system of marker-tape designations that is uniform and consistent with system used by manufacturer for factory-installed connections.
  - 3. Coordinate identification with Project Drawings, manufacturer's wiring diagrams, and operation and maintenance manual.
- K. Locations of Underground Lines: Identify with underground-line warning tape for power, lighting, communication, and control wiring and optical-fiber cable.
  - 1. Limit use of underground-line warning tape to direct-buried cables.
  - 2. Install underground-line warning tape for direct-buried cables and cables in raceways.
- L. Workspace Indication: Install floor marking tape to show working clearances in the direction of access to live parts. Workspace shall comply with NFPA 70 and 29 CFR 1926.403 unless otherwise indicated. Do not install at flush-mounted panelboards and similar equipment in finished spaces.
- M. Warning Labels for Indoor Cabinets, Boxes, and Enclosures for Power and Lighting: Self-adhesive warning labels.
  - 1. Comply with 29 CFR 1910.145.
  - 2. Identify system voltage with black letters on an orange background.
  - 3. Apply to exterior of door, cover, or other access.
  - 4. For equipment with multiple power or control sources, apply to door or cover of equipment, including, but not limited to, the following:
    - a. Power-transfer switches.
    - b. Controls with external control power connections.
- N. Arc Flash Warning Labeling: Self-adhesive thermal transfer vinyl labels.
  - 1. Comply with NFPA 70E and ANSI Z535.4.
  - 2. Comply with Section 26 05 74 "Overcurrent Protective Device Arc-Flash Study" requirements for arc-flash warning labels.
- O. Operating Instruction Signs: Install instruction signs to facilitate proper operation and maintenance of electrical systems and items to which they connect. Install instruction signs with approved legend where instructions are needed for system or equipment operation.
- P. Emergency Operating Instruction Signs: Install instruction signs with white legend on a red background with minimum ~~3/8-inch~~ (10-mm-) high letters for emergency instructions at equipment used for power transfer or load shedding.
- Q. Equipment Identification Labels: On each unit of equipment, install unique designation label that is consistent with wiring diagrams, schedules, and operation and maintenance manual. Apply



labels to disconnect switches and protection equipment, central or master units, control panels, control stations, terminal cabinets, and racks of each system. Systems include power, lighting, control, communication, signal, monitoring, and alarm unless equipment is provided with its own identification.

1. Labeling Instructions:
  - a. Elevated Components: Increase sizes of labels and letters to those appropriate for viewing from the floor.
  - b. Fasten mechanically fastened labels with appropriate mechanical fasteners that do not change the NEMA or NRTL rating of the enclosure.
2. Equipment To Be Labeled:
  - a. Panelboards: Typewritten directory of circuits in the location provided by panelboard manufacturer.
  - b. Enclosures and electrical cabinets.
  - c. Lighting control relay cabinets.
  - d. Access doors and panels for concealed electrical items.
  - e. Switchgear.
  - f. Switchboards.
  - g. Transformers: Label that includes tag designation shown on Drawings for the transformer, feeder, and panelboards or equipment supplied by the secondary.
  - h. Emergency system boxes and enclosures.
  - i. Motor-control centers.
  - j. Enclosed switches.
  - k. Enclosed circuit breakers.
  - l. Enclosed controllers.
  - m. Variable-speed controllers.
  - n. Push-button stations.
  - o. Power-transfer equipment.
  - p. Contactors.
  - q. Remote-controlled switches, dimmer modules, and control devices.
  - r. Battery-inverter units.
  - s. Battery racks.
  - t. Power-generating units.
  - u. Monitoring and control equipment.
  - v. UPS equipment.
  - w. Communications Equipment Racks.
  - x. Fire Alarm System.
  - y. Access Control System.
  - z. Overhead Paging System.
  - aa. Nurse Call System.

**END OF SECTION**

**SECTION 26 09 23**  
**LIGHTING CONTROL DEVICES**

**PART 1 - GENERAL**

**1.1 RELATED DOCUMENTS**

- A. Drawings and general provisions of the Contract, including General and Supplementary Conditions and Division 01 Specification Sections, apply to this Section.

**1.2 SUMMARY**

- A. Section Includes:
  - 1. Photoelectric switches.
  - 2. Standalone daylight-harvesting switching controls.
  - 3. Daylight-harvesting dimming controls.
  - 4. Room Controllers.
  - 5. Stand Alone Indoor occupancy sensors.
  - 6. Lighting contactors.
  - 7. Emergency shunt relays.
  - 8. Low-Voltage Controllers
- B. Related Requirements:
  - 1. Section 26 27 26 "Wiring Devices" for wall-box dimmers, wall-switch occupancy sensors, low voltage dimmers, low voltage switches, and manual light switches.

**1.3 ACTION SUBMITTALS**

- A. Product Data: For each type of product.
- B. Shop Drawings: Show installation details for occupancy and light-level sensors.
  - 1. Submit complete scale drawing showing recommended location for each sensor, optimized for project conditions and coverage patterns for submitted devices.
  - 2. Interconnection diagrams showing field-installed wiring.
  - 3. Include diagrams for power, signal, and control wiring.
  - 4. Include legend for each light switch keyed to the lighting control shop drawings indicating engraving/labelling factory applied to each switch.

**1.4 INFORMATIONAL SUBMITTALS**

- A. Field quality-control reports.

**1.5 CLOSEOUT SUBMITTALS**

- A. Operation and Maintenance Data: For each type of lighting control device to include in emergency, operation, and maintenance manuals.

**PART 2 - PRODUCTS****2.1 OUTDOOR PHOTOELECTRIC SWITCHES**

- A. **Manufacturers:** Subject to compliance with requirements, provide products by one of the following:
1. [Cooper Industries, Inc.](#)
  2. [Intermatic, Inc.](#)
  3. [Leviton Manufacturing Co., Inc.](#)
  4. [NSi Industries LLC.](#)
  5. [TE Connectivity Ltd.](#)
- B. Description: Solid state, with SPST dry contacts rated for 1800 VA, to operate connected load, complying with UL 773.
1. Listed and labeled as defined in NFPA 70, by a qualified testing agency, and marked for intended location and application.
  2. Light-Level Monitoring Range: **1.5 to 10 fc (16.14 to 108 lux)**, with an adjustment for turn-on and turn-off levels within that range.
  3. Time Delay: Thirty-second minimum, to prevent false operation.
  4. Lightning Arrester: Air-gap type.
  5. Mounting: Twist lock complying with NEMA C136.10, with base.

**2.2 DAYLIGHT-HARVESTING SWITCHING CONTROLS**

- A. Provide products that are of the same manufacturer or compatible with the manufacturers listed in Section 26 09 43, Relay Based Lighting Controls.
- B. **Manufacturers:** Subject to compliance with requirements, provide products by one of the following:
1. [Eaton \(Cooper Controls\), Inc.](#)
  2. [Lutron, Inc.](#)
  3. [Leviton Manufacturing Co., Inc.](#)
  4. Philips Controls
  5. Acuity Controls
  6. Nextlite
  7. ETC
  8. Douglas Controls
  9. WattStopper
- C. Ceiling-Mounted Switching Controls: Solid-state, light-level sensor unit, with separate power pack, to detect changes in indoor lighting levels that are perceived by the eye.
- D. Electrical Components, Devices, and Accessories:
1. Listed and labeled as defined in NFPA 70, by a qualified testing agency, and marked for intended location and application.
  2. Operating Ambient Conditions: Dry interior conditions, **32 to 120 deg F (0 to 49 deg C)**.
  3. Sensor Output: Contacts rated to operate the associated power pack, complying with UL 773A. Sensor is powered by the power pack.
  4. Power Pack: Dry contacts rated for **20-A** ballast load at 120- and 277-V ac. Sensor has 24-V dc, 150-mA, Class 2 power source, as defined by NFPA 70.
  5. General Space Sensors Light-Level Monitoring Range: **10 to 200 fc (108 to 2152 lux)**, with an adjustment for turn-on and turn-off levels within that range.

6. Atrium Space Sensors Light-Level Monitoring Range: 100 to 1000 fc (1080 to 10 800 lux), with an adjustment for turn-on and turn-off levels within that range.
7. Skylight Sensors Light-Level Monitoring Range: 1000 to 10,000 fc (10 800 to 108 000 lux), with an adjustment for turn-on and turn-off levels within that range.
8. Time Delay: Adjustable from 5 to 300 seconds to prevent cycling.
9. Set-Point Adjustment: Equip with deadband adjustment of 25, 50, and 75 percent above the "on" set point, or provide with separate adjustable "on" and "off" set points.
10. Test Mode: User selectable, overriding programmed time delay to allow settings check.
11. Control Load Status: User selectable to confirm that load wiring is correct.
12. Indicator: Two digital displays to indicate the beginning of on-off cycles.

### 2.3 DAYLIGHT-HARVESTING DIMMING CONTROLS

- A. Provide products that are of the same manufacturer or compatible with the manufacturers listed in Section 26 09 43, Relay Based Lighting Controls.
- B. **Manufacturers:** Subject to compliance with requirements, provide products by one of the following:
  1. [Eaton \(Cooper Controls\), Inc.](#)
  2. [Lutron, Inc.](#)
  3. [Leviton Manufacturing Co., Inc.](#)
  4. Philips Controls
  5. Acuity Controls
  6. NextLite
  7. Douglas Controls
  8. ETC
  9. WattStopper
- C. System Description: Sensing daylight and electrical lighting levels, the system adjusts the indoor electrical lighting levels. As daylight increases, the lights are dimmed.
  1. Lighting control set point is based on two lighting conditions:
    - a. When no daylight is present (target level).
    - b. When significant daylight is present.
  2. System programming is done with two hand-held, remote-control tools.
    - a. Initial setup tool.
    - b. Tool for occupants to adjust the target levels by increasing the set point up to 25 percent, or by minimizing the electric lighting level.
- D. Ceiling-Mounted Dimming Controls: Solid-state, light-level sensor unit, with separate controller unit, to detect changes in lighting levels that are perceived by the eye. The separate dimming control may be located in the appropriate relay cabinet for these circuits.
  1. Listed and labeled as defined in NFPA 70, by a qualified testing agency, and marked for intended location and application.
  2. Sensor Output: 0- to 10-V dc to operate electronic dimming ballasts. Sensor is powered by controller unit.
  3. Power Pack: Sensor has 24-V dc, Class 2 power source, as defined by NFPA 70.
  4. Light-Level Sensor Set-Point Adjustment Range: 20 to 100 fc (120 to 600 lux).

### 2.4 ROOM CONTROLLERS

- A. Room Controllers are used to independently control lighting and switched receptacles.

- B. Provide products that are compatible with Indoor Occupancy Sensors.
- C. Digitally addressable room controller with the following functions.
  - 1. Autonomous space control.
  - 2. Networking to a central Dialog control system.
  - 3. Networking to a central BACnet based management system.
- D. The Room Controller shall consist of:
  - 1. A universal voltage type (120Vac/277Vac/347Vac) power supply.
  - 2. Four 20A rated relays complete with manual override. Circuit Load rating dependent on usage. One circuit dedicated for 20A receptacle control.
  - 3. Four 0-10V control channels, capable of 100mA current sinking
  - 4. A port to connect downstream switches, occupancy sensors and daylight sensors.
  - 5. A port to connect upstream to BACnet IP building management system. The Controller shall communicate using native BACnet command objects appropriate for the application.
  - 6. An indicating LED to aid in locating the controller in a darkened ceiling space.
  - 7. Circuit testing buttons
  - 8. Capable of connecting with WUL-3924
  - 9. Output 24Vac 120mA
  - 10. Relay Ratings
    - a. 20A Suitable for General Purpose Loads @ 120/277 VAC
    - b. 20A Suitable for Standard Ballasts and Tungsten Loads @ 120/277 VAC
    - c. 16A Suitable for Electronic Ballasts @ 120/277 VAC
    - d. 0.5HP @120/277 VAC.
  - 11. The Room Controller relays shall be connected such that 120Vac plug load(s) and 277Vac lighting loads can be switched by a single Controller with no additional add-ons or remote modules
  - 12. The Room Controller shall mount to electrical junction box via threaded ½” chase nipple. No other mounting hardware shall be required.
  - 13. Switches shall connect to the lighting control network via a common low voltage, 2-wire, non-polarized data line.
    - a. Switches shall be factory configured and programmed to control one or more outputs in the lighting control system.
    - b. Switches can be programmed for preset control to set a specific lighting scene.
    - c. Switches, with LED indicators to indicate both ON and OFF output/group status, shall be available with 2 or 4 single button switches per gang. Switch to fit standard Decora opening.
    - d. Switches and switch hardware shall mount to standard wall boxes.
    - e. Each switch shall provide a location for a label to identify function. The label shall be under a clear plastic cover and shall be field replaceable should the operation of the switch change. Permanently etched switches are not acceptable.
  - 14. Dimmer switches shall be connected to the lighting control network via a common low voltage 2-wire, non-polarized data line.
    - a. Dimmer switches shall be capable of raising or lowering light levels of individual or groups of lighting fixtures.
    - b. Dimmer switches shall be capable of controlling across the full range of dimming settings within a period of three (3) seconds.
  - 15. Space Control Requirements:
    - a. Provide manual-on / auto-off control for lighting in all spaces that are controlled by a Room Controller.
    - b. Provide auto-on / auto-off control for all switched receptacles that are controlled by a Room Controller.
    - c. Provide auto-on / auto-off control for HVAC serving all spaces that contain a Room Controller. Control to be provided by either two-wire signal based on relay contact position or direct communication with the building management system

- using BACnet commands. Coordinate with building management system installer.
16. Shall have a built in dimmer memory, the light output will remain at the previous setting when the lights are turned off and back on.

## 2.5 INDOOR OCCUPANCY SENSORS

- A. Provide products that are of the same manufacturer or compatible with the manufacturers listed in Section 26 09 43, Relay Based Lighting Controls.
- B. General Requirements for Sensors: Wall- or ceiling-mounted, solid-state indoor occupancy sensors with a separate power pack.
  1. Listed and labeled as defined in NFPA 70, by a qualified testing agency, and marked for intended location and application.
  2. Operation: Unless otherwise indicated, turn lights on when coverage area is occupied, and turn them off when unoccupied; with a time delay for turning lights off, adjustable over a minimum range of 1 to 15 minutes.
  3. In locations where the sensor or the local switch is/are marked "VS" the sensor shall turn the lights off automatically upon room vacancy. The lights shall turn on only upon activation from the associated wall station.
  4. Sensor Output: Contacts rated to operate the connected relay, complying with UL 773A. Sensor is powered from the power pack.
  5. Power Pack: Dry contacts rated for 20-A ballast load at 120- and 277-V ac, for 13-A tungsten at 120-V ac, and for 1 hp at 120-V ac Sensor has 24-V dc, 150-mA, Class 2 power source, as defined by NFPA 70.
  6. Mounting:
    - a. Sensor: Suitable for mounting in any position on a standard outlet box.
    - b. Relay: Externally mounted through a 1/2-inch (13-mm) knockout in a standard electrical enclosure.
    - c. Time-Delay and Sensitivity Adjustments: Recessed and concealed behind hinged door.
  7. Indicator: Digital display, to show when motion is detected during testing and normal operation of sensor.
  8. Bypass Switch: Override the "on" function in case of sensor failure.
  9. Automatic Light-Level Sensor: Adjustable from 2 to 200 fc (21.5 to 2152 lux); turn lights off when selected lighting level is present.
- C. Dual-Technology Type: Ceiling mounted; detect occupants in coverage area using both PIR and ultrasonic detection methods. The particular technology or combination of technologies that control on-off functions is selectable in the field by operating controls on unit.
  1. Sensitivity Adjustment: Separate for each sensing technology.
  2. Detector Sensitivity: Detect occurrences of 6-inch- (150-mm-) minimum movement of any portion of a human body that presents a target of not less than 36 sq. in. (232 sq. cm), and detect a person of average size and weight moving not less than 12 inches (305 mm) in either a horizontal or a vertical manner at an approximate speed of 12 inches/s (305 mm/s).
  3. Detection Coverage (Standard Room): Detect occupancy anywhere within a circular area of 1000 sq. ft. (93 sq. m) when mounted on a 96-inch- (2440-mm-) high ceiling.
  4. Remote powerpacks using one or more sensors shall be used to cover space as indicated on drawings.
  5. Device shall be vacancy sensing (in conjunction with local wall station) if marked "VS". Otherwise device shall be occupancy sensing.

## 2.6 SWITCHBOX-MOUNTED OCCUPANCY SENSORS

- A. Provide products that are of the same manufacturer or compatible with the manufacturers listed in Section 260943, Relay Based Lighting Controls.
- B. General Requirements for Sensors: Automatic-wall-switch occupancy sensor, suitable for mounting in a single gang switchbox.
  - 1. Listed and labeled as defined in NFPA 70, by a qualified testing agency, and marked for intended location and application,
  - 2. Operating Ambient Conditions: Dry interior conditions, 32 to 120 deg F (0 to 49 deg C).
  - 3. Switch Rating: Not less than 800-VA LED at 120 V, 1200-VA LED loads at 277 V,
- C. Wall-Switch Sensor:
  - 1. Standard Range: 180-degree field of view, field adjustable from 180 to 40 degrees; with a minimum coverage area of 900 sq. ft. (84 sq. m).
  - 2. Sensing Technology: Dual technology - PIR and ultrasonic.
  - 3. Switch Type: SP. SP, manual "on," automatic "off."
  - 4. Voltage: Dual voltage, 120 and 277 V;
  - 5. Ambient-Light Override: Concealed, field-adjustable, light-level sensor from 10 to 150 fc (108 to 1600 lux). The switch prevents the lights from turning on when the light level is higher than the set point of the sensor.
  - 6. Concealed, field-adjustable, "off" time-delay selector at up to 30 minutes.
  - 7. Adaptive Technology: Self-adjusting circuitry detects and memorizes usage patterns of the space and helps eliminate false "off" switching.
  - 8. Device shall be Vacancy sensing if marked VS or occupancy sensing if not otherwise marked.

## 2.7 LIGHTING CONTACTORS

- A. Manufacturers: Subject to compliance with requirements, provide products by one of the following:
  - 1. [Allen-Bradley/Rockwell Automation](#).
  - 2. [ASCO Power Technologies, LP; a division of Emerson Electric Co.](#)
  - 3. [Eaton Corporation](#).
  - 4. GE Industrial Systems; Total Lighting Control.
  - 5. [Square D; a brand of Schneider Electric](#).
- B. Description: Electrically operated, electrically held, combination-type lighting contactors with fusible switch complying with NEMA ICS 2 and UL 508.
  - 1. Current Rating for Switching: Listing or rating consistent with type of load served, including tungsten filament, inductive, and high-inrush ballast (ballast with 15 percent or less total harmonic distortion of normal load current).
  - 2. Fault Current Withstand Rating: Equal to or exceeding the available fault current at the point of installation.
  - 3. Enclosure: Comply with NEMA 250.
  - 4. Provide with control and pilot devices as indicated on Drawings, matching the NEMA type specified for the enclosure.
- C. Interface with DDC System for HVAC: Provide hardware interface to enable the DDC system for HVAC to monitor and control lighting control systems and contactors.
  - 1. Monitoring: On-off status
  - 2. Control: On-off operation

**2.8 EMERGENCY SHUNT RELAY**

- A. **Manufacturers:** Subject to compliance with requirements, provide products by one of the following:
1. [Eaton \(Cooper Controls\), Inc.](#)
  2. [Lutron, Inc.](#)
  3. [Leviton Manufacturing Co., Inc.](#)
  4. Philips Controls
  5. Acuity Controls
  6. NextLite
  7. Douglas Controls
  8. Wattstopper
- B. Description: Normally closed, electrically held relay, arranged for wiring in parallel with automatic switching contacts; complying with UL 924.
1. Coil Rating: as scheduled.

**2.9 LOW-VOLTAGE CONTROLLERS**

- A. Low-Voltage Controllers are used to turn on and dim line voltage lighting safely when used with Nurse Call Pillow Speakers, Bed Side-Rail Controls and Momentary Dry Contact Switches.
- B. Manufacturers: Subject to compliance with requirements, provide the following:
1. Curbell Medical Products (Basis of Design is # LVC-2000-001)
- C. Description: 3 Channel lighting controller to continuously dim 2 channels using 0-10 vdc signals to the dimming LED drivers for the ambient light and reading light channels in the luminaire and to switch one channel via the LED driver(s) for the exam light portion of the luminaire. Controller shall have control inputs from nurse call pillow speaker contacts and also be switched from wall switches as shown.
- D. Installation: Lighting Controller shall be installed above the accessible ceiling outside the patient room for ease of access. All leads shall be extended from the switches, luminaire and nurse call system in an approved manner. Installer shall provide a NEMA 12 enclosure suitable for the purpose and mount the controller in this box. Observe required high and low voltage separation and physical barriers. Label the cover with the words "LIGHTING CONTROLLER FOR ROOM #####".

**2.10 CONDUCTORS AND CABLES**

- A. Power Wiring to Supply Side of Remote-Control Power Sources: Not smaller than No. 12 AWG. Comply with requirements in Section 26 05 19 "Low-Voltage Electrical Power Conductors and Cables."
- B. Classes 2 and 3 Control Cable: Multiconductor cable with stranded-copper conductors not smaller than No. 22 AWG. Comply with requirements in Section 26 05 19 "Low-Voltage Electrical Power Conductors and Cables."
- C. Class 1 Control Cable: Multiconductor cable with stranded-copper conductors not smaller than No. 18 AWG. Comply with requirements in Section 26 05 19 "Low-Voltage Electrical Power Conductors and Cables."



**PART 3 - EXECUTION****3.1 SENSOR INSTALLATION**

- A. Coordinate layout and installation of ceiling-mounted devices with other construction that penetrates ceilings or is supported by them, including light fixtures, HVAC equipment, smoke detectors, fire-suppression systems, and partition assemblies.
- B. Install and aim sensors in locations to achieve not less than 90 percent coverage of areas indicated. Do not exceed coverage limits specified in manufacturer's written instructions.

**3.2 CONTACTOR INSTALLATION**

- A. Mount electrically held lighting contactors with elastomeric isolator pads to eliminate structure-borne vibration, unless contactors are installed in an enclosure with factory-installed vibration isolators.

**3.3 WIRING INSTALLATION**

- A. Wiring Method: Comply with Section 260519 "Low-Voltage Electrical Power Conductors and Cables." Minimum conduit size is **1/2 inch (13 mm)**.
- B. Wiring within Enclosures: Comply with NECA 1. Separate power-limited and nonpower-limited conductors according to conductor manufacturer's written instructions.
- C. Size conductors according to lighting control device manufacturer's written instructions unless otherwise indicated.
- D. Splices, Taps, and Terminations: Make connections only on numbered terminal strips in junction, pull, and outlet boxes; terminal cabinets; and equipment enclosures.

**3.4 IDENTIFICATION**

- A. Identify components and power and control wiring according to Section 260553 "Identification for Electrical Systems."
  - 1. Identify controlled circuits in lighting contactors.
  - 2. Identify circuits or luminaires controlled by photoelectric and occupancy sensors at each sensor.
- B. Label time switches and contactors with a unique designation.

**3.5 FIELD QUALITY CONTROL**

- A. Testing Agency: Owner will engage a qualified commissioning agent to evaluate lighting control devices and perform tests and inspections.
- B. Manufacturer's Field Service: Engage a factory-authorized service representative to test and inspect components, assemblies, and equipment installations, including connections.

- C. Perform the following tests and inspections with the assistance of a factory-authorized service representative:
  - 1. Operational Test: After installing time switches and sensors, and after electrical circuitry has been energized, start units to confirm proper unit operation.
  - 2. Test and adjust controls and safeties. Replace damaged and malfunctioning controls and equipment.
- D. Lighting control devices will be considered defective if they do not pass tests and inspections.
- E. Prepare test and inspection reports.

### **3.6 ADJUSTING**

- A. Occupancy Adjustments: When requested within **12** months from date of Substantial Completion, provide on-site assistance in adjusting sensors to suit actual occupied conditions. Provide up to **two** visits to Project during other-than-normal occupancy hours for this purpose.
  - 1. For occupancy and motion sensors, verify operation at outer limits of detector range. Set time delay to suit Owner's operations.
  - 2. For daylighting controls, adjust set points and deadband controls to suit Owner's operations.
  - 3. Align high-bay occupancy sensors using manufacturer's laser aiming tool.

### **3.7 DEMONSTRATION**

- A. Coordinate demonstration of products specified in this Section with demonstration requirements for low-voltage, programmable lighting control systems specified in Section 260943.13 "Addressable-Fixture Lighting Controls" and Section 26 09 43 "Relay-Based Lighting Controls."
- B. Train Owner's maintenance personnel to adjust, operate, and maintain lighting control devices.

**END OF SECTION**

**SECTION 26 27 26**  
**WIRING DEVICES**

**PART 1 - GENERAL**

**1.1 RELATED DOCUMENTS**

- A. Drawings and general provisions of the Contract, including General and Supplementary Conditions and Division 01 Specification Sections, apply to this Section.

**1.2 SUMMARY**

- A. Section Includes:
  - 1. Receptacles, receptacles with integral GFCI, and associated device plates.
  - 2. Twist-locking receptacles.
  - 3. USB charger devices.
  - 4. Isolated-ground receptacles.
  - 5. Hospital-grade receptacles.
  - 6. Tamper-resistant receptacles.
  - 7. Weather-resistant receptacles.
  - 8. Snap switches and wall-box dimmers.
  - 9. Floor service outlets (floor boxes) and poke-through assemblies.
  - 10. Pendant Cord Connector Devices (Drop Cords).
  - 11. Cord Reels

**1.3 DEFINITIONS**

- A. EMI: Electromagnetic interference.
- B. GFCI: Ground-fault circuit interrupter.
- C. Pigtail: Short lead used to connect a device to a branch-circuit conductor.
- D. RFI: Radio-frequency interference.

**1.4 ADMINISTRATIVE REQUIREMENTS**

- A. Coordination:
  - 1. Receptacles for Owner-Furnished Equipment: Match plug configurations.
  - 2. Cord and Plug Sets: Match equipment requirements.

**1.5 ACTION SUBMITTALS**

- A. Product Data: For each type of product.

**1.6 INFORMATIONAL SUBMITTALS**

- A. Field quality-control reports.

**1.7 CLOSEOUT SUBMITTALS**

- A. Operation and Maintenance Data: For wiring devices to include in all manufacturers' packing-label warnings and instruction manuals that include labeling conditions.

**PART 2 - PRODUCTS****2.1 MANUFACTURERS**

- A. **Manufacturers:** Subject to compliance with requirements, provide products by one of the following:
  - 1. [Eaton \(Arrow Hart\)](#).
  - 2. [Hubbell Incorporated; Wiring Device-Kellems](#).
  - 3. [Leviton Manufacturing Co., Inc.](#)
  - 4. [Pass & Seymour/Legrand \(Pass & Seymour\)](#).
- B. Source Limitations: Obtain each type of wiring device and associated wall plate from single source from single manufacturer.

**2.2 GENERAL WIRING-DEVICE REQUIREMENTS**

- A. Wiring Devices, Components, and Accessories: Listed and labeled as defined in NFPA 70, by a qualified testing agency, and marked for intended location and application.
- B. Comply with NFPA 70.
- C. All devices must be manufactured for use with modular plug-in connectors, shall comply with UL 2459 and shall be made with stranded building wire. Devices shall comply with the requirements in this Section.

**2.3 STRAIGHT-BLADE RECEPTACLES**

- A. Hospital-Grade, Tamper Resistant, Duplex Convenience Receptacles, 125 V, 20 A: Comply with NEMA WD 1, NEMA WD 6 Configuration 5-20R, UL 498 Supplement sd, and FS W-C-596.
  - 1. Description: Single-piece, rivetless, nickel-plated, all-brass grounding system. Nickel-plated, brass mounting strap. Mechanical shutter system to help prevent insertion of foreign objects. Labeled shall comply with NFPA 70, "Health Care Facilities" Article, "Pediatric Locations" Section.
- B. Isolated-Ground, Duplex Convenience Receptacles, 125 V, 20 A: Comply with NEMA WD 1, NEMA WD 6 Configuration 5-20R, UL 498, and FS W-C-596.
  - 1. Description: Straight blade; equipment grounding contacts shall be connected only to the green grounding screw terminal of the device and with inherent electrical isolation from mounting strap. Isolation shall be integral to receptacle construction and not dependent on removable parts.

- C. Tamper-Resistant Convenience Receptacles, 125 V, 20 A: Comply with NEMA WD 1, NEMA WD 6 Configuration 5-20R, UL 498 Supplement sd, and FS W-C-596.
  - 1. Description: Labeled shall comply with NFPA 70, "Health Care Facilities" Article, "Pediatric Locations" Section.

## 2.4 GFCI RECEPTACLES

- A. General Description:
  - 1. Straight blade, non-feed-through type.
  - 2. Comply with NEMA WD 1, NEMA WD 6, UL 498, UL 943 Class A, and FS W-C-596.
  - 3. Include indicator light that illuminates only when the GFCI has malfunctioned or tripped and no longer provides proper GFCI protection.
- B. Tamper-Resistant GFCI Convenience Receptacles, 125 V, 20 A:
- C. Hospital-Grade, Tamper Resistant, Duplex GFCI Convenience Receptacles, 125 V, 20 A: Comply with NEMA WD 1, NEMA WD 6 Configuration 5-20R, UL 498 Supplement sd, and FS W-C-596.

## 2.5 TWIST-LOCKING RECEPTACLES

- A. Provide NEMA configurations as indicated on drawings.

## 2.6 PENDANT CORD-CONNECTOR DEVICES

- A. Description:
  - 1. Matching, locking-type plug and receptacle body connector.
  - 2. NEMA WD 6 Configurations L5-20P and L5-20R, heavy-duty grade, and FS W-C-596.
  - 3. Body: Nylon, with screw-open, cable-gripping jaws and provision for attaching external cable grip.
  - 4. External Cable Grip: Woven wire-mesh type made of high-strength, galvanized-steel wire strand, matched to cable diameter, and with attachment provision designed for corresponding connector.

## 2.7 CORD REELS

- A. **Manufacturers:** Subject to compliance with requirements, provide products by one of the following:
  - 1. Kitchen Leash by APC Group
- B. Description:
  - 1. Molded Polypropylene Housing.
  - 2. Retracting cord with adjustable stop.
  - 3. SJOW Power cord, 10 foot; rated 200 degrees.
  - 4. Receptacles Dual Duplex NEMA 5-20R unless noted otherwise.
  - 5. Impact: UL746C
  - 6. Hose Down: CSA 6.8.2
  - 7. Strain Relief: CSA 6.4
  - 8. Flame Retardant: UL 94-94V-2
  - 9. Mounting Bracket for ceiling mount.

**2.8 CORD AND PLUG SETS**

- A. Description:
1. Match voltage and current ratings and number of conductors to requirements of equipment being connected.
  2. Cord: Rubber-insulated, stranded-copper conductors, with Type SOW-A jacket; with green-insulated grounding conductor and ampacity of at least 130 percent of the equipment rating.
  3. Plug: Nylon body and integral cable-clamping jaws. Match cord and receptacle type for connection.

**2.9 TOGGLE SWITCHES**

- A. Comply with NEMA WD 1, UL 20, and FS W-S-896.
- B. Switches, 120/277 V, 20 A:
1. Single Pole and Three Way:
    - a. **Manufacturers:** Subject to compliance with requirements, provide products by one of the following:
      - 1) [Eaton \(Arrow Hart\)](#).
      - 2) [Hubbell Incorporated; Wiring Device-Kellems](#).
      - 3) [Leviton Manufacturing Co., Inc.](#)
      - 4) [Pass & Seymour/Legrand \(Pass & Seymour\)](#).
- C. Key-Operated Switches, 120/277 V, 20 A:
1. Description: Single pole, with factory-supplied key in lieu of switch handle.
    - a. Public Restrooms and Other Spaces: Keyed switch, heavy duty specification grade (Pass & Seymour PS20AC1-WL or equivalent).
    - b. Behavioral Health Patient Accessible Spaces: Keyed locking switch, extra heavy duty specification grade security switch (Pass & Seymour PS20AC1-KL or equivalent). Coordinate common or differentiated keying of multiple switches with owner.
- D. Momentary Contact Switches: 2-Button, Single Pole, Low-voltage switch, mounts in standard single gang ring.
- E. Key-Operated, Single-Pole, Double-Throw, Momentary-Contact, Center-off Switches: 120/277 V, 20 A; for use with mechanically held lighting contactors, with factory-supplied key in lieu of switch handle.
- F. Decora style rocker switches are not permitted.

**2.10 WALL-BOX DIMMERS**

- A. Dimmer Switches: Modular, full-wave, solid-state units with integral, quiet on-off switches, with audible frequency and EMI/RFI suppression filters.
- B. Control: Continuously adjustable full width slider; with single-pole or three-way switching. Comply with UL 1472.

- C. Incandescent Lamp Dimmers: 120 V; control shall follow square-law dimming curve. On-off switch positions shall bypass dimmer module for off.
  - 1. These shall be used to control power modules driving large quantity of LED drivers using 0-10VDC control signals. This interface shall operate either 120 or 277 volt circuits, 200 ma rating.
- D. Decora style rocker switches are not permitted.
- E. LED and Low Voltage Dimmer Switches:
  - 1. Modular; compatible with LED drivers; trim potentiometer to adjust low-end dimming used where "LR" is shown, otherwise full range of 1% to 100% of lumen output or as noted.
  - 2. Maximum of four (4) buttons per gang.
  - 3. Dimmer shall operate either 120 or 277 volt circuits, 28 ma minimum rating.
  - 4. Touch dimming switches shall cover the full range of dimming with a single press-and-hold function in not more than three (3) seconds.
  - 5. Switches, with LED indicators to indicate both ON and OFF status, shall be available with 2 or 4 single button switches per gang. Switch to fit standard Decora opening.
  - 6. Switches and switch hardware shall mount to standard wall boxes.
  - 7. Each switch shall provide a location for a label to identify function. The label shall be under a clear plastic cover and shall be field replaceable should the operation of the switch change. Permanently etched switches are not acceptable unless specifically noted otherwise.
- F. Slide Dimmer Locations:
  - 1. Exam Rooms, Imaging Rooms, Operating Rooms, Procedure Rooms, Recovery Bays, and Imaging Control Rooms: Provide slide dimmer switches; do not provide touch dimming switches in these spaces except when an integrated component of an antimicrobial or integrated operating room ceiling system.

## 2.11 WALL PLATES

- A. Single and combination types shall match corresponding wiring devices.
  - 1. Plate-Securing Screws: Metal with head color to match plate finish.
  - 2. Material for Finished Spaces, except Operating Rooms, Food Service Kitchens, and Behavioral Health Spaces: Smooth, high-impact thermoplastic.
  - 3. Material for Operating Rooms and Food Service Kitchen: **0.035-inch- (1-mm-)** thick, satin-finished, Type 302 stainless steel.
  - 4. Material for Behavioral Health Spaces: Smooth, nylon, unbreakable, with a minimum of two (2) screws per gang; provide Torx head tamper resistant screws.
  - 5. Material for Unfinished Spaces: Galvanized steel.
  - 6. Material for Damp Locations: Cast aluminum with spring-loaded lift cover, and listed and labeled for use in wet and damp locations.
- B. Wet-Location, Weatherproof Cover Plates: NEMA 250, complying with Type 3R, weather-resistant, die-cast aluminum with lockable, weatherproof-in-use cover.

## 2.12 FLOOR SERVICE FITTINGS

- A. **Manufacturers:** Subject to compliance with requirements, provide products by the following:
  - 1. [Wiremold / Legrand](#).
- B. Type: Modular, flush-type, dual- or multi- service units suitable for wiring method used.

- C. Compartments: Barrier separates power from voice and data communication cabling.
- D. Service Plate: Round, die-cast aluminum with satin finish.
- E. Power Receptacle: NEMA WD 6 Configuration 5-20R, gray finish, unless otherwise indicated.
- F. Voice and Data Communication Outlet: Two modular, keyed, color-coded, RJ-45 jacks for UTP cable complying with requirements in owner’s Section 27 00 00 requirements.
- G. Description by Device Type:

FB1	Flush, Dual Service, Furniture Feed. One .75” conduit for power and One 2” conduit for data cabling. See plans for circuits and data drops. Finish selected by architect.	Legrand EFBFF Hubbell CFB2G30/2GCFFCVR
FB4	Flush, Dual Service, one piece finish flange. Four gang capacity. One .75” conduit for power and one 2” conduit for data cabling. See plans for circuits and data drops. Finish selected by architect.	Legrand EFG45S Hubbell CFB2G30/24GCCVR
FB6	Flush, Dual Service, one piece finish flange. Six gang capacity. One .75” conduit for power and one 2” conduit for data cabling. See plans for circuits and data drops. Finish selected by architect.	Legrand EFB6S Evolution Hubbell CFB6G30/610GCCVR
FB8	Flush, Dual Service, one piece finish flange. Eight gang capacity. One .75” conduit for power and one 2” conduit for data cabling. See plans for circuits and data drops. Finish selected by architect.	Legrand EFB8S Evolution
FB10	Flush, Dual Service, one piece finish flange. Ten gang capacity. One .75” conduit for power and one 2” conduit for data cabling. See plans for circuits and data drops. Finish selected by architect.	Legrand EFB10S Evolution Hubbell CFB10G30/610GCCVR
FB11	Flush single service floor box suitable for the wiring method used. NEMA 5-20R duplex receptacle with brushed aluminum flange and cover plate. Hinged receptacle covers. Housing material shall be stamped steel above grade and cast iron at grade. Provide appropriate carpet and tile flanges.	Legrand 880MS(CS)/817/828 Hubbell B2431/S3825

**2.13 POKE-THROUGH ASSEMBLIES**

- A. **Manufacturers:** Subject to compliance with requirements, provide products by the following:
  - 1. **Wiremold / Legrand.**
- B. **Description:**
  - 1. Factory-fabricated and -wired assembly of below-floor junction box with multichanneled, through-floor raceway/firestop unit and detachable matching floor service-outlet assembly.
  - 2. Comply with UL 514 scrub water exclusion requirements.
  - 3. Size: Selected to fit cored holes in floor and matched to floor thickness.
  - 4. Fire Rating: Unit is listed and labeled for fire rating of floor-ceiling assembly.
  - 5. Closure Plug: Arranged to close unused cored openings and reestablish fire rating of floor.
- C. **Description by Device Type:**

PT1	Flush, Dual Service, 4” Diameter Furniture Feed Poke-Thru. One piece finish flange. One .75” conduit for power, One 1.5” conduit for data cabling. See plans for circuits and data drops. Finish selected by architect.	Legrand 4FFATC Hubbell PT73FFS/FRF3
PT2	Flush, Dual Service Capable, 4”Diameter Poke-Thru. One .75” conduit for power, one 1.5” conduit for data cabling. Two Gang Capacity. See plans for circuits and data drops. Receptacles shall be NEMA 5-20R, Finish selected by architect.	Legrand 4AT Evolution Hubbell S1R4PT



PT3	Flush, Dual Service Capable, 6"Diameter Poke-Thru. One .75" conduit for power, one 1.5" conduit for data cabling. Three Gang Capacity. See plans for circuits and data drops. Receptacles shall be NEMA 5-20R, Finish selected by architect.	Legrand 6AT Evolution Hubbell SIR6PT
PT8	Flush, Dual Service Capable, 8"Diameter Poke-Thru. One .75" conduit for power, one 2" conduit for data cabling. Five Gang Capacity. See plans for circuits and data drops. Receptacles shall be NEMA 5-20R, Finish selected by architect.	Legrand 8AT Evolution Hubbell SIR8PT
PT10	Flush, Dual Service Capable, 10"Diameter Poke-Thru. One .75" conduit for power, one 2" conduit for data cabling. Eight Gang Capacity. See plans for circuits and data drops. Receptacles shall be NEMA 5-20R, Finish selected by architect.	Legrand 10AT Evolution Hubbell SIR10PT
PT11	Flush single service floor box suitable for the wiring method used. NEMA 5-20R duplex receptacle with brushed aluminum flange and cover plate. Hinged receptacle covers.	Legrand RC7CTC Hubbell PT7FS/FRF

**2.14 FINISHES**

- A. Device Color:
  - 1. Wiring Devices Connected to Normal Power System: Gray in Food Service Kitchen. As selected by Architect in other finished spaces unless otherwise indicated or required by NFPA 70 or device listing.
  - 2. Wiring Devices Connected to Essential Power System: Red.
  - 3. Isolated-Ground Receptacles: Orange.
- B. Wall Plate Color:
  - 1. Plastic covers: Match device color.
  - 2. Cover plates for receptacles mounted above data racks in TEC and TDR rooms: Provide blue cover plates for receptacles served by UPS-A and red cover plates for receptacles served by UPS-B.

**PART 3 - EXECUTION**

**3.1 INSTALLATION**

- A. Comply with NECA 1, including mounting heights listed in that standard, unless otherwise indicated.
- B. Coordination with Other Trades:
  - 1. Protect installed devices and their boxes. Do not place wall finish materials over device boxes and do not cut holes for boxes with routers that are guided by riding against outside of boxes.
  - 2. Keep outlet boxes free of plaster, drywall joint compound, mortar, cement, concrete, dust, paint, and other material that may contaminate the raceway system, conductors, and cables.
  - 3. Install device boxes in brick or block walls so that the cover plate does not cross a joint unless the joint is troweled flush with the face of the wall.
  - 4. Install wiring devices after all wall preparation, including painting, is complete.
- C. Conductors:

1. Do not strip insulation from conductors until right before they are spliced or terminated on devices.
  2. Strip insulation evenly around the conductor using tools designed for the purpose. Avoid scoring or nicking of solid wire or cutting strands from stranded wire.
  3. The length of free conductors at outlets for devices shall meet provisions of NFPA 70, Article 300, without pigtails.
  4. Existing Conductors:
    - a. Cut back and pigtail, or replace all damaged conductors.
    - b. Straighten conductors that remain and remove corrosion and foreign matter.
    - c. Pigtail existing conductors is permitted, provided the outlet box is large enough.
- D. Device Installation:
1. Replace devices that have been in temporary use during construction and that were installed before building finishing operations were complete.
  2. Keep each wiring device in its package or otherwise protected until it is time to connect conductors.
  3. Do not remove surface protection, such as plastic film and smudge covers, until the last possible moment.
  4. Connect devices to branch circuits using pigtails that are not less than **6 inches (152 mm)** in length.
  5. When there is a choice, use side wiring with binding-head screw terminals. Wrap solid conductor tightly clockwise, two-thirds to three-fourths of the way around terminal screw.
  6. Use a torque screwdriver when a torque is recommended or required by manufacturer.
  7. When conductors larger than No. 12 AWG are installed on 15- or 20-A circuits, splice No. 12 AWG pigtails for device connections.
  8. Tighten unused terminal screws on the device.
  9. When mounting into metal boxes, remove the fiber or plastic washers used to hold device-mounting screws in yokes, allowing metal-to-metal contact.
- E. Receptacle Orientation:
1. Install ground pin of vertically mounted receptacles up, and on horizontally mounted receptacles to the right.
  2. Install hospital-grade receptacles in patient-care areas with the ground pin or neutral blade at the top.
- F. Device Plates: Do not use oversized or extra-deep plates. Repair wall finishes and remount outlet boxes when standard device plates do not fit flush or do not cover rough wall opening.
- G. Dimmers:
1. Install dimmers within terms of their listing.
  2. Install unshared neutral conductors on line and load side of dimmers according to manufacturers' device listing conditions in the written instructions.
  3. Install 0-10VDC control wiring in conduit with power wiring. Use conductors with insulation equivalent to insulation of power wiring.
- H. Arrangement of Devices: Unless otherwise indicated, mount flush, with long dimension vertical and with grounding terminal of receptacles on top. Group adjacent switches under single, multigang wall plates.
- I. Adjust locations of floor boxes and pokethroughs to suit arrangement of partitions and furnishings.

**3.2 GFCI RECEPTACLES**

- A. Install non-feed-through-type GFCI receptacles where protection of downstream receptacles is not required.

**3.3 IDENTIFICATION**

- A. Comply with Section 260553 "Identification for Electrical Systems."
- B. Identify each receptacle with panelboard identification and circuit number. Use hot, stamped, or engraved machine printing with black-filled lettering on face of plate, and durable wire markers or tags inside outlet boxes.

**3.4 FIELD QUALITY CONTROL**

- A. Perform the following tests and inspections with the assistance of a factory-authorized service representative:
  - 1. In healthcare facilities, prepare reports that comply with recommendations in NFPA 99.
  - 2. Test Instruments: Use instruments that comply with UL 1436.
  - 3. Test Instrument for Convenience Receptacles: Digital wiring analyzer with digital readout or illuminated digital-display indicators of measurement.
- B. Tests for Convenience Receptacles:
  - 1. Line Voltage: Acceptable range is 105 to 132 V.
  - 2. Percent Voltage Drop under 15-A Load: A value of 6 percent or higher is unacceptable.
  - 3. Ground Impedance: Values of up to 2 ohms are acceptable.
  - 4. GFCI Trip: Test for tripping values specified in UL 1436 and UL 943.
  - 5. Using the test plug, verify that the device and its outlet box are securely mounted.
  - 6. Tests shall be diagnostic, indicating damaged conductors, high resistance at the circuit breaker, poor connections, inadequate fault current path, defective devices, or similar problems. Correct circuit conditions, remove malfunctioning units and replace with new ones, and retest as specified above.
- C. Test straight-blade convenience outlets in patient-care areas for the retention force of the grounding blade according to NFPA 99. Retention force shall be not less than **4 oz. (115 g)**. Submit test report indicating each receptacle and test result.
- D. Wiring device will be considered defective if it does not pass tests and inspections.
- E. Prepare test and inspection reports.

**END OF SECTION**

**SECTION 26 51 19**  
**LED INTERIOR LIGHTING****PART 1 - GENERAL****1.1 RELATED DOCUMENTS**

- A. Drawings and general provisions of the Contract, including General and Supplementary Conditions and Division 01 Specification Sections, apply to this Section.

**1.2 SUMMARY**

- A. Section Includes:
1. Interior solid-state luminaires that use LED technology.
  2. Lighting fixture supports.
  3. Standby Emergency Power supplies for individual luminaires
- B. Related Requirements:
1. Section 26 09 23 "Lighting Control Devices" for automatic control of lighting, including time switches, photoelectric relays, occupancy sensors, and multipole lighting relays and contactors.
  2. Section 26 09 36 "Standalone Multipreset Modular Dimming Controls" for architectural dimming systems and for fluorescent dimming controls with dimming ballasts specified in interior lighting Sections.
  3. Section 26 09 43 "Relay-Based Lighting Controls" for manual or programmable control systems with low-voltage control wiring or data communication circuits.

**1.3 DEFINITIONS**

- A. CCT: Correlated color temperature.
- B. CRI: Color Rendering Index.
- C. Fixture: See "Luminaire."
- D. IP: International Protection or Ingress Protection Rating.
- E. LED: Light-emitting diode.
- F. Lumen: Measured output of lamp and luminaire, or both.
- G. Luminaire: Complete lighting unit, including lamp, reflector, and housing.

**1.4 ACTION SUBMITTALS**

- A. Product Data: For each type of product.
1. Arrange in order of luminaire designation.
  2. Include data on features, accessories, and finishes.

3. Include physical description and dimensions of luminaires.
  4. Include emergency lighting units, including batteries and chargers.
  5. Include life, output (lumens, CCT, and CRI), and energy efficiency data.
  6. Photometric data and adjustment factors based on laboratory tests, complying with IESNA Lighting Measurements Testing and Calculation Guides, of each lighting fixture type. The adjustment factors shall be for lamps and accessories identical to those indicated for the lighting fixture as applied in this Project. Report data compliant with IES LM-79 and IES LM-80. Only Absolute Photometry is acceptable.
    - a. Manufacturers' Certified Data: Photometric data certified by manufacturer's laboratory with a current accreditation under the National Voluntary Laboratory Accreditation Program for Energy Efficient Lighting Products (NVLAP).
- B. Shop Drawings: For nonstandard or custom luminaires.
1. Include plans, elevations, sections, and mounting and attachment details.
  2. Include details of luminaire assemblies. Indicate dimensions, weights, loads, required clearances, method of field assembly, components, and location and size of each field connection.
  3. Include diagrams for power, signal, and control wiring.
- C. LEED Submittals:
1. Product Data for Credit IEQ 4.2: For paints and coatings, documentation including printed statement of VOC content.
  2. Laboratory Test Reports for Credit IEQ 4.2: For paints and coatings, documentation indicating that products comply with the testing and product requirements of the California Department of Public Health's "Standard Method for the Testing and Evaluation of Volatile Organic Chemical Emissions from Indoor Sources Using Environmental Chambers."
- D. Samples: For each luminaire and for each color and texture with standard factory-applied finish.
- E. Samples for Initial Selection: For each type of luminaire with custom factory-applied finishes.
1. Include Samples of luminaires and accessories involving color and finish selection.
- F. Samples for Verification: For each type of luminaire.
1. Include Samples of luminaires and accessories to verify finish selection.
- G. Product Schedule: For luminaires and lamps. Use same designations indicated on Drawings.

## 1.5 INFORMATIONAL SUBMITTALS

- A. Coordination Drawings: Reflected ceiling plan(s) and other details, drawn to scale, on which the following items are shown and coordinated with each other, using input from installers of the items involved:
1. Lighting luminaires.
  2. Suspended ceiling components.
  3. Partitions and millwork that penetrate the ceiling or extend to within **12 inches (300 mm)** of the plane of the luminaires.
  4. Structural members to which equipment and or luminaires will be attached.
  5. Initial access modules for acoustical tile, including size and locations.
  6. Items penetrating finished ceiling, including the following:
    - a. Other luminaires.
    - b. Air outlets and inlets.
    - c. Speakers.
    - d. Sprinklers.

- e. Access panels.
- f. Ceiling-mounted projectors.
- g.
- 7. Moldings.
- B. Qualification Data: For testing laboratory providing photometric data for luminaires.
- C. Seismic Qualification Certificates: For luminaires, accessories, and components, from manufacturer.
  - 1. Basis for Certification: Indicate whether withstand certification is based on actual test of assembled components or on calculation.
  - 2. Dimensioned Outline Drawings of Equipment Unit: Identify center of gravity and locate and describe mounting and anchorage provisions.
- D. Detailed description of equipment anchorage devices on which the certification is based and their installation requirements.
- E. Product Certificates: For each type of luminaire.
- F. Product Test Reports: For each luminaire, for tests performed by manufacturer or a qualified testing agency holding NVLAP accreditation.
- G. Sample warranty.

## 1.6 CLOSEOUT SUBMITTALS

- A. Operation and Maintenance Data: For luminaires and lighting systems to include in operation and maintenance manuals.
  - 1. Provide a list of all lamp types LED Modules and LED Drivers used on Project; use ANSI and manufacturers' codes.

## 1.7 MAINTENANCE MATERIAL SUBMITTALS

- A. Furnish extra materials that match products installed and that are packaged with protective covering for storage and identified with labels describing contents citing lighting fixture types.
  - 1. Lamps: 2 for every 100 of each type and rating installed. Furnish at least one of each type.
  - 2. Diffusers and Lenses: One for every 100 of each type and rating installed. Furnish at least one of each type.
  - 3. Globes and Guards: One for every 20 of each type and rating installed. Furnish at least one of each type.

## 1.8 QUALITY ASSURANCE

- A. Luminaire Photometric Data Testing Laboratory Qualifications: Luminaire manufacturer's laboratory that is accredited under the NVLAP for Energy Efficient Lighting Products.
- B. Luminaire Photometric Data Testing Laboratory Qualifications: Provided by an independent agency, with the experience and capability to conduct the testing indicated, that is an NRTL as defined by OSHA in 29 CFR 1910.7, accredited under the NVLAP for Energy Efficient Lighting Products, and complying with the applicable IES testing standards.

- C. Provide luminaires from a single manufacturer for each luminaire type.
- D. Each luminaire type shall be binned within a three-step MacAdam Ellipse to ensure color consistency among luminaires.
- E. Mockups: For interior lighting luminaires in room or module mockups, complete with power and control connections.
  1. Obtain Architect's approval of luminaires in mockups before starting installations.
  2. Maintain mockups during construction in an undisturbed condition as a standard for judging the completed Work.
  3. Approval of mockups does not constitute approval of deviations from the Contract Documents contained in mockups unless Architect specifically approves such deviations in writing.
  4. Subject to compliance with requirements, approved mockups may become part of the completed Work if undisturbed at time of Substantial Completion.

### **1.9 DELIVERY, STORAGE, AND HANDLING**

- A. Protect finishes of exposed surfaces by applying a strippable, temporary protective covering before shipping.

### **1.10 WARRANTY**

- A. Warranty: Manufacturer and Installer agree to repair or replace components of luminaires that fail in materials or workmanship within specified warranty period.
- B. Warranty Period: Five year(s) from date of Substantial Completion.

## **PART 2 - PRODUCTS**

### **2.1 PERFORMANCE REQUIREMENTS**

- A. Seismic Performance: Luminaires shall withstand the effects of earthquake motions determined according to ASCE/SEI 7.
- B. Seismic Performance: Luminaires and lamps shall be labeled vibration and shock resistant.
  1. The term "withstand" means "the luminaire will remain in place without separation of any parts when subjected to the seismic forces specified and the luminaire will be fully operational during and after the seismic event."

### **2.2 LUMINAIRE REQUIREMENTS**

- A. Electrical Components, Devices, and Accessories: Listed and labeled as defined in NFPA 70, by a qualified testing agency, and marked for intended location and application.
- B. NRTL Compliance: Luminaires for hazardous locations shall be listed and labeled for indicated class and division of hazard by an NRTL.
- C. FM Global Compliance: Luminaires for hazardous locations shall be listed and labeled for indicated class and division of hazard by FM Global.

- D. Recessed Fixtures: Comply with NEMA LE 4.
- E. Bulb shape complying with ANSI C79.1.
- F. Lamp base complying with ANSI C81.61 or IEC 60061-1, where employing universal base or mount.
- G. CRI of minimum 80. CCT of 3500 K.
- H. L70 rated lamp life of 50,000 hours.
- I. Lamps dimmable as indicated or 0.5 to 100 percent of maximum light output, via 0-10 VDC control signal or, where indicated, Digital Dimming Control Signal.
- J. Field Replaceable driver.
- K. Nominal Operating Voltage: Universal voltage 120 V ac or 277 V ac unless scheduled differently.
  - 1. Lens Thickness: At least 0.125 inch (3.175 mm) minimum unless otherwise indicated.
- L. Housings:
  - 1. Hydroformed, cast or extruded-aluminum housing and heat sink suitable for the environment.
  - 2. Anodized or powder-coat finish.

### 2.3 LED LAMPS AND DRIVERS:

- A. Minimum CRI Ra- 82 or as specified.
- B. Lumen output shall be Luminaire Lumens or Delivered Lumens. Source lumens shall not be used.
- C. Each luminaire type shall be binned within a three-step MacAdam Ellipse to ensure color consistency among luminaires.
- D. LED Rated life L70 of 50,000 hours per (IES LM-80). Luminaire shall maintain LED operating temperature to achieve this rating per TM-21.
- E. Flicker: No visible or detectable flicker, operating on all dimmed intensities.
- F. Dimming drivers shall be compatible with the control method shown on the drawings. All dimmed drivers shall use 0-10vdc control unless specified differently. Minimum level as scheduled.
- G. Inrush current shall be reported and the lighting controls adjusted for inrush of LED product supplied.
- H. THD: THD shall not exceed 80%.
- I. Minimum driver efficiency shall be 83%.
- J. LED module shall be replaceable in the field using modules with digitally traceable matching modules.



- K. Luminaire shall be NRTL Listed at intended operating temperature.
- L. Photometry shall be measured or absolute photometry. Derived or calculated photometry shall not be provided for consideration.
- M. Approved Manufacturers- Drivers
  - 1. General Electric.
  - 2. Philips.
  - 3. Osram / Sylvania.
  - 4. Lutron
  - 5. EldoLED
  - 6. Thomas Research
- N. Approved Manufacturers- LEDs
  - 1. General Electric
  - 2. Philips
  - 3. Osram
  - 4. Cree
  - 5. Xicato
  - 6. Nichia
- O. Approved Manufacturers for Luminaires shall be as scheduled.

## 2.4 MATERIALS

- A. Metal Parts:
  - 1. Free of burrs and sharp corners and edges.
  - 2. Sheet metal components shall be steel unless otherwise indicated.
  - 3. Form and support to prevent warping and sagging.
- B. Doors, Frames, and Other Internal Access: Smooth operating, free of light leakage under operating conditions, and designed to permit relamping without use of tools. Designed to prevent doors, frames, lenses, diffusers, and other components from falling accidentally during relamping and when secured in operating position.
- C. Diffusers and Globes:
  - 1. Acrylic Diffusers: One hundred percent virgin acrylic plastic, with high resistance to yellowing and other changes due to aging, exposure to heat, and UV radiation.
  - 2. Glass: Annealed crystal glass unless otherwise indicated.
  - 3. Lens Thickness: At least **0.125 inch (3.175 mm)** minimum unless otherwise indicated.
- D. Housings:
  - 1. Hydroformed, cast or extruded-aluminum housing and heat sink suitable for the environment.
  - 2. Anodized or powder-coat finish.
- E. Factory-Applied Labels: Comply with UL 1598. Include recommended lamps and line wattage. Locate labels where they will be readily visible to service personnel, but not seen from normal viewing angles when lamps are in place.
  - 1. Label shall include the following lamp characteristics:
    - a. "USE ONLY" and include specific lamp type.
    - b. Lamp diameter, shape, size, wattage, and coating.
    - c. CCT and CRI for all luminaires.

## 2.5 METAL FINISHES

- A. Variations in finishes are unacceptable in the same piece. Variations in finishes of adjoining components are acceptable if they are within the range of approved Samples and if they can be and are assembled or installed to minimize contrast.

## 2.6 LUMINAIRE FIXTURE SUPPORT COMPONENTS

- A. Comply with requirements in Section 26 05 29 "Hangers and Supports for Electrical Systems" for channel and angle iron supports and nonmetallic channel and angle supports.
- B. Single-Stem Hangers: **1/2-inch (13-mm)** steel tubing with swivel ball fittings and ceiling canopy. Finish same as luminaire.
- C. Wires: ASTM A 641/A 641 M, Class 3, soft temper, zinc-coated steel, **12 gauge (2.68 mm)**.
- D. Rod Hangers: **3/16-inch (5-mm)** minimum diameter, cadmium-plated, threaded steel rod.
- E. Hook Hangers: Integrated assembly matched to luminaire, line voltage, and equipment with threaded attachment, cord, and locking-type plug.

## 2.7 GENERAL REQUIREMENTS FOR EMERGENCY LIGHTING

- A. Electrical Components, Devices, and Accessories: Listed and labeled as defined in NFPA 70, by a qualified testing agency, and marked for intended location and application.
- B. NRTL Compliance: Fabricate and label emergency lighting units, exit signs, and batteries to comply with UL 924.
- C. Comply with NFPA 70 and NFPA 101.
- D. Comply with NEMA LE 4 for recessed luminaires.
- E. Internal Type Emergency Power Unit: Self-contained, modular, battery-inverter unit, factory mounted within luminaire body and compatible with LED light source and driver, including dimming driver.
  - 1. Emergency Connection: Operate luminaire continuously at an output of 5 watts upon loss of normal power. Connect unswitched circuit to battery-inverter unit and switched circuit to luminaire ballast.
  - 2. Operation: Relay automatically turns driver/led module on when power-supply circuit voltage drops to 80 percent of nominal voltage or below. Lamp automatically disconnects from battery when voltage approaches deep-discharge level. When normal voltage is restored, relay disconnects lamps from battery, and battery is automatically recharged and floated on charger.
  - 3. Environmental Limitations: Rate equipment for continuous operation under the following conditions unless otherwise indicated:
    - a. Ambient Temperature: Less than **0 deg F** or exceeding **104 deg F** with an average value exceeding **95 deg** over a 24-hour period.
    - b. Ambient Storage Temperature: Not less than **minus 4 deg F** and not exceeding **140 deg F**
    - c. Humidity: More than 95 percent (condensing).

- d. Altitude: Exceeding 3300 feet
- 4. Battery: Sealed, maintenance-free, lead-acid type.
- 5. Charger: Fully automatic, solid-state, constant-current type with sealed power transfer relay.
- 6. Integral Self-Test: Factory-installed electronic device automatically initiates code-required test of unit emergency operation at required intervals. Test failure is annunciated by an integral audible alarm and a flashing red LED.

### **PART 3 - EXECUTION**

#### **3.1 EXAMINATION**

- A. Examine substrates, areas, and conditions, with Installer present, for compliance with requirements for installation tolerances and other conditions affecting performance of the Work.
- B. Examine roughing-in for luminaire to verify actual locations of luminaire and electrical connections before fixture installation. Proceed with installation only after unsatisfactory conditions have been corrected.

#### **3.2 TEMPORARY LIGHTING**

- A. If approved by the Architect, use selected permanent luminaires for temporary lighting. When construction is sufficiently complete, clean luminaires used for temporary lighting and install new lamps.

#### **3.3 INSTALLATION**

- A. Comply with NECA 1.
- B. Install luminaires level, plumb, and square with ceilings and walls unless otherwise indicated.
- C. Supports:
  - 1. Sized and rated for luminaire weight.
  - 2. Able to maintain luminaire position after cleaning and repair.
  - 3. Provide support for luminaire without causing deflection of ceiling or wall.
  - 4. Luminaire mounting devices shall be capable of supporting a horizontal force of 100 percent of luminaire weight and vertical force of 400 percent of luminaire weight.
- D. Flush-Mounted Luminaire Support:
  - 1. Secured to outlet box.
  - 2. Attached to ceiling structural members at four points equally spaced around circumference of luminaire.
  - 3. Trim ring flush with finished surface.
- E. Wall-Mounted Luminaire Support:
  - 1. Attached to structural members or approved backer plate in walls
  - 2. Do not attach luminaires directly to gypsum board.
- F. Ceiling-Mounted Luminaire Support:
  - 1. Ceiling mount with four 5/32-inch- (4-mm) diameter steel wire or aircraft cable supports.

2. Ceiling mount with hook mount.
- G. Suspended Luminaire Support:
1. Pendants and Rods: Where longer than **48 inches (1200 mm)**, brace to limit swinging.
  2. Stem-Mounted, Single-Unit Luminaires: Suspend with twin-stem hangers. Support with approved outlet box and accessories that hold stem and provide damping of luminaire oscillations. Support outlet box vertically to building structure using approved devices.
  3. Continuous Rows of Luminaires: Use tubing or stem for wiring at one point and wire support for suspension for each unit length of luminaire chassis, including one at each end.
  4. Do not use ceiling grid as support for pendant luminaires. Connect support wires or rods to building structure.
- H. Ceiling-Grid-Mounted Luminaires:
1. Secure to any required outlet box.
  2. Secure luminaire to the luminaire opening using approved fasteners in a minimum of four locations, spaced near corners of luminaire.
  3. Use approved devices and support components to connect luminaire to ceiling grid and building structure in a minimum of four locations, spaced near corners of luminaire.
- I. Comply with requirements in Section 26 05 19 "Low-Voltage Electrical Power Conductors and Cables" for wiring connections.

### **3.4 IDENTIFICATION**

- A. Identify system components, wiring, cabling, and terminals. Comply with requirements for identification specified in Section 26 05 53 "Identification for Electrical Systems."

### **3.5 FIELD QUALITY CONTROL**

- A. Perform the following tests and inspections:
1. Operational Test: After installing luminaires, switches, and accessories, and after electrical circuitry has been energized, test units to confirm proper operation.
  2. Test for Emergency Lighting: Interrupt power supply to demonstrate proper operation. Verify transfer from normal power to battery power and retransfer to normal.
- B. Luminaire will be considered defective if it does not pass operation tests and inspections.
- C. Prepare test and inspection reports.

### **3.6 STARTUP SERVICE**

- A. Comply with requirements for startup specified in Section 26 09 43 "Relay-Based Lighting Controls."

### **3.7 ADJUSTING**

- A. Occupancy Adjustments: When requested within 12 months of date of Substantial Completion, provide on-site assistance in adjusting the direction of aim of luminaires to suit occupied conditions. Make up to two visits to Project during other-than-normal hours for this purpose. Some of this work may be required during hours of darkness.

1. During adjustment visits, inspect all luminaires. Replace luminaires that are defective.
2. Parts and supplies shall be manufacturer's authorized replacement parts and supplies.
3. Adjust the aim of luminaires in the presence of the Architect.

**END OF SECTION**

---

**SECTION 27000****GENERAL COMMON CONDITIONS FOR ALL  
COMMUNICATION SECTIONS****PART 1 - GENERAL****1.1 RELATED DOCUMENTS**

- A. Drawings and General Provisions of the Contract, including General and Supplementary Conditions and Division 01 Specification Sections, and other documents as designated, apply to this Document.
- B. See Division 7 and section 27 01 00 Part 3 for additional requirements.

**1.2 RELATED SECTIONS**

- A. Specifications throughout all Divisions of the Project Manual are directly applicable to this section, and this section is directly applicable to them.
  - 1. All Division 27 Sections
  - 2. Requirements of the following Division 26 sections apply to this section
    - a. Basic electrical requirements
    - b. Basic electrical materials and methods
    - c. Grounding, earthing, and bonding
  - 3. Division 21 Fire Suppression
  - 4. Division 22 Plumbing
  - 5. Division 23 HVAC
  - 6. Division 28 Electronic Safety and Security

**1.3 SUMMARY**

- A. The work on many processes in this section are not part of the Division 27 contract. The respective trades shall include their portions, and administration topics that are applicable to all Division 27 Sections in their proposals.
- B. This document is based upon the 2018 Construction Specification Institute (CSI) Master Format numbers and titles for sections within Division 27: Communications.
- C. Where IT or Owner representation is stipulated in this Division, it shall be provided by the Data Center Operations Infrastructure Cabling team.

**1.4 SUBMITTALS**

- A. Product data shall be supplied for any parts/equipment that does not match the specified part number.
- B. Shop drawings
  - 1. Labeling schedules and layouts in owner designated electronic format
  - 2. Cabling administrative drawings

**1.5 CONDITIONS**

- A. Drawings and General provisions of the contract, including Uniform General Conditions, Supplementary General Conditions, architectural plans and specifications, requirements of Division 1, electrical, mechanical, plumbing, audio visual, security and telecommunications specifications and plans apply to the communications section, and shall be consider a part of this section. The contractor shall read all sections in their

- entirety and apply them as appropriate for work in this section.
- B. Prior to beginning installation, a kick-off meeting to properly coordinate the tray installation and expectations should be held. It should be arranged by the General Contractor, and at a minimum include representatives of the following trades: FP&D, Electrical (Div. 26), Structured cable, Nurse Call, paging, building automation and control, plumbing, HVAC, fire sprinkler, framing, and others as applicable. The Data Center Operations Infrastructure Cabling Team will lead the meeting.
- C. Conflicts:
1. Drawings and specifications are to be used in conjunction with one another and to supplement one another. In general, the drawings determine the nature and quality of the installation, materials, and tests. The quantities are derived from the drawings, details, listings, and manufacturer's directions.
    - a. Final order counts and distances are the contractor's responsibility.
  2. If there is an apparent conflict between the drawings and specifications, or between specification sections, the items with the greater quality or quantity shall be submitted, estimated, and installed.
  3. Clarification with the Owner and/or Owner's Representative about these items shall be made prior to the ordering and installation.
- D. Owner / Contractor
1. The Architect/Project Manager will submit appropriate scope of work information that will allow the contractor to appropriately plan and bid the project.
- E. Contractor
1. Furnish all labor, materials, tools, equipment and services for the installation described herein. Provide add/deduct unit pricing for all components as part of the bid response. Base fixed price add/deduct units on an average cable length of 175 linear feet.
  2. The Contractor shall procure and maintain for the duration of this agreement, insurance against claims.
  3. Use of Subcontractors: Successful bidder shall inform the Owner's contact and/or General Contractor in writing about the intention to use Subcontractors and the scope of work for which they are being hired. The Owner or Owner's designated contact must approve the chosen Subcontractors in writing prior to the Subcontractor's hiring and start of any work. The low voltage Subcontractor must be approved and certified. Refer to the listing in appendix 7.
  4. Use of Subcontractors: The Contractor's designated project manager will be recognized as the single point of contact. The Project manager shall oversee all work performed to ensure compliance with specifications as outlined in bid documents (which includes all specifications and drawings) to ensure a quality installation.

## 1.6 SCOPE OF WORK:

- A. This establishes a communications infrastructure to be used as signal pathways for voice, high-speed data transmission, and other low voltage services. Contractor shall:
1. Comply with all Master Specifications documents and the following requirements for a complete project installation.
  2. Provide a structured cabling system as described hereafter that includes, but is not limited to, supplying, installing, labeling and testing of fiber backbone, fiber and voice riser cable; data copper, fiber, and voice copper horizontal cabling, cable connectors, communications outlets and terminations, patch cables, and equipment racks/cabinets for networking hardware and patch panels.
  3. All requirements and specifications will be enforced. Cable pathways and runs to individual outlets are not shown in their entirety but shall be provided as if shown in their entirety.

4. Coordinate with electrical tradespersons to verify conduit routing does not cause cabling to exceed allowable link length.
5. Follow industry standard installation procedures, including BICSI Installation Standard and guidelines as well as specified manufacturers standard recommended procedures and installation practices for communications cable to assure that the mechanical and electrical transmission characteristics of this cable plant and equipment are maintained.
6. The Division 27 work shall be performed by an approved, certified installer.
7. The low voltage communications Subcontractor shall complete non-concealed work.

#### 1.7 REFERENCE STANDARDS:

- A. The latest published edition of a reference shall be applicable to this Project unless identified by a specific edition date.
- B. All reference amendments adopted prior to the effective date of the Contract shall be applicable to this Project.
- C. The publications listed below form a part of this specification. The publications are referred to in the text by basic designation only.
- D. Specific reference in specifications to codes, rules, regulations, standards, manufacturer's instructions, or requirements of regulatory agencies shall mean reference to the latest printed edition of each in effect at the date of contract.
- E. Codes and Standards (Most recent editions with addenda/TSB, etc.) All materials, installation and workmanship shall meet or exceed the applicable requirements and standards addressed within the references listed in **Appendix 04**.

#### 1.8 DEFINITIONS:

- A. Definitions and Abbreviations are listed in **Appendix 05**:

### PART 2 - PRODUCTS

#### 2.1 PRODUCTS AND WORK NOT included BY DIVISION 27

- A. Others shall separately purchase and/or provide certain equipment and miscellaneous items that will be installed during the installation process. Such items may not be indicated in the documents. Contractor shall coordinate with the Owner and his suppliers when considering:
  1. Provision and installation of phone systems, computer hardware, and related networking software and equipment.
  2. Provision and installation of multi-port routers, hubs in communications rooms.
    - a. TEC/TDR UPS's are owner provided.
  3. Communications grounding bus bars and grounding wires connecting to the main building electrode system by Division 26.
  4. Dedicated power panels, ground bus bars, circuits and utility outlets.
  5. Installation and finishing of fire-rated plywood backboards.
  6. Building mechanical ductwork, cooling/heating system, and environmental control sensors.
  7. Communication pathway devices such as, conduits, conduit sleeves, back boxes, and penetrations in walls and floors. Including, but not limited to concealed work, office spaces and open areas.
  8. Provision and installation of modular furniture and millwork.

### PART 3 - PENETRATIONS



3.1 THE WORK IN THIS SECTION IS IN DIVISION 7 CONTRACT; AND VERIFIED COMPLETE AT PROJECT TURNOVER.

- A. Wall Penetrations - Fire - Smoke – Sound
1. All fire, smoke, and sound wall penetrations must be correctly made to protect the safety of patients and employees. A facility is designed/architected and built with fire integrity that must not be lost as the building is modified over its lifetime.
  2. The items listed often penetrate 1 – and 2 – hour fire-resistance-rated (FRR) assemblies. General requirements for filling the space between the item in question and the wall are found in NFPC 101® Section 8.2.3.2.4.2. There is the option to either fill the space with appropriately rated fire-stop material or protect the space with an approved device designed to maintain the fire resistance of the wall.
  3. If a sleeve is used around the item that transverses the wall, the sleeve must be installed into the wall without any opening between the sleeve and the wall. The open space within the sleeve must then be filled with appropriately rated fire stop.
- B. All items listed in 1 through 2 must have penetrations in fire-resistance-rated assemblies filled to maintain the integrity of the fire barrier.
1. Conduits
    - a. When conduit passes through a wall that is either rated or must be fire-stopped due to lack of sprinklers in the compartment, it is essential to fill any gap around the conduit as described above.
  2. Cables/Wires
    - a. Sometimes cables or wires are passed through a penetration contained in a fire wall as a single installation. This often happens in a health care organization with communication cables. Even in these cases, the penetration must be patched appropriately.
  3. NOTE: Fire, smoke, and sound wall penetrations are also governed by local and state building codes.
  4. NOTE: This requirement applies to all departments, organizations, employees, and/or vendors who perform structured cable work in the facilities for:
    - a. Telephony and Computer networks, fire, smoke, and sound wall penetrations, alarm systems, security systems, HVAC Control or sensors, patient entertainment systems, announcing systems, nurse call, telemetry, RFID, etc.
  5. NOTE: While this document is written specifically for low voltage wiring, the JCAHO standards apply for any fire or smoke wall penetration. As you perform work in the facility, if you note any existing penetrations that are not up to standard, please notify the construction Project Manager immediately.
  6. While Facility Engineering has the overall responsibility, each department, organization, employee, and/or vendor has the responsibility to follow the process in obtaining a permit from facility engineering before work is started and to follow the guidelines to maintain the fire/smoke wall integrity.
- C. Process:
1. NOTE: This process applies to any person, group, and/or vendor who perform low voltage cable installations at any Intermountain facility or clinic.
    - a. Fire/Smoke Walls
      - 1) Any Vendor, department, and/or person needing to do any cable work that involves wall penetrations, adding to existing or new, are required to obtain a “Low Voltage Cable Work Permit” from Facility Engineer.
    - b. Above Ceiling Work
      - 1) Any vendor, department, and/or person needing to do any cable work above ceiling tiles, adding to existing or new, are required

- to obtain all required permits.
  - c. Above Ceiling Permit to be obtained from Facilities Management
    - 1) The permit requires detail information as to what work is being done, where the work will be done. The permit will also state the current approved sealing compound for the facility and specific requirements for conduits etc.
    - 2) There may also be specific rules regarding how work may be conducted in certain areas of the hospital. NOTE: Different manufacture's sealing products can NOT be used in the same penetration. Therefore, if an additional cable is added to an existing penetration, and you don't have the same brand of caulk, you must remove all of the caulk and re-do the seal completely.
  - d. ICRA Permit to be obtain from Infectious Preventionist
  - e. Hot Work Permit to be obtain from Facilities Engineer
- 2. Quality of Work
  - a. Facility Engineering Orientation

### 3.2 MEASUREMENT PROCEDURES:

- A. The Contractor shall
  - 1. Coordinate supports, adjacent construction, and fixture locations to ensure actual dimensions correspond to established dimensions.
  - 2. Verify dimensions in areas of installation by field measurements before fabrication and indicate measurements and scale on shop drawings.
  - 3. Coordinate fabrication schedule with construction progress to avoid delaying the work.
  - 4. Where field measurements cannot be made without delaying the work, establish dimensions and coordinate with the General Contractor.
  - 5. When approved, proceed with fabricating units without field measurements.

### 3.3 CHANGES

- A. ALTERNATES:
  - 1. If an alternate material is proposed that is equal to or exceeds specified requirements, Contractor shall provide manufacturers' specifications in writing for Owner approval prior to purchase and installation.
  - 2. Substitutions of material by the Contractor shall be in writing complete with written manufacturers' specifications. The material substituted shall not void, alter or change manufacturers' structured cabling system warranty.
  - 3. Contractor shall:
    - a. Provide a complete cabling infrastructure according to these written specifications and drawings. If the Owner changes the scope of work to be performed by the Contractor, it shall be in writing.
    - b. Promptly respond to these changes with a complete material list, including pricing, and labor in writing presented to the Owner for approval. Also include unit pricing.
    - c. Do not proceed with any additional scope of work without a signed approval by the Owner.
  - 4. Owner will not pay for additional work performed by the Contractor without signed approval of these changes. Contractor will submit a copy of signed change order upon billing.
  - 5. The Owner's Infrastructure Cable team will be the final judge of acceptability, with review by Owner's Representative and the distribution of the acceptance by the Architect. No substitute shall be ordered, installed or utilized without the

Architect's prior written verification of acceptance from the Owner's Infrastructure Cable team.

**B. SUBSTITUTION PROCEDURES**

1. Substitution may be considered when a product becomes unavailable through no fault of the Contractor.
2. Document each request with complete data substantiating compliance of proposed substitution with Contract Documents. Include in each request for substitution:
  - a. Product identification, manufacturer's name and address.
  - b. Product Data: Description, performance and test data, reference standards, finishes and colors.
  - c. Samples: Finishes
  - d. Complete and accurate drawings indicating construction revisions required (if any) to accommodate substitutions.
  - e. Data relating to changes required in construction schedule.
  - f. Cost comparison between specified and proposed substitution.
3. Substitutions will not be considered when they are indicated or implied on shop drawing or product data submittals, without separate written request, or when acceptance will require revision to the Contract Documents.
4. The Owner will be the final judge of acceptability, with review by Owner's Representative and the distribution of the acceptance by the Architect.
5. No substitute shall be ordered, installed or utilized without the Architect's prior written verification of acceptance from the Owner's Infrastructure Cable team.

**PART 4 - EXECUTION**

**4.1 QUALITY ASSURANCE**

**A. Regulatory Requirements:**

1. Contractor shall supply all city, county, and state telecommunication cabling permits required by appropriate governing agency.
2. Prior to commencing work, the Contractor and staff shall secure all required Intermountain Healthcare permits including, but not limited to; facility sign in, ceiling work permits, hot work permits, and confined space permits.
3. Contractor shall be city, county, and state-licensed and/or bonded as required for communications/low voltage cabling systems work.

**B. Certifications:**

1. Contractor shall submit an up-to-date and valid certification verifying qualifications of the Contractor and installers to perform the work specified herein at time of bid submission.
2. Contractor shall have a complete working knowledge of low voltage cabling applications such as, but not limited to data, voice and video network systems.
3. Contracting firm shall have installed similar-sized systems in at least ten (10) other projects in the last five years prior to this bid and be regularly engaged in the business of installation of the types of systems specified in this document. Certification shall include, but not be limited to, items such as name and location of project contacts and numbers, total square footage, total number of cables/drops, types of media, etc.
4. Contractor shall provide certificates for the appropriate insurance coverage as defined in contract documents.
5. All installer personnel that will be assigned to this project shall be listed in a qualification document. 50% of the personnel working on the job site shall have a minimum of 3 years' experience in the installation of the types of systems, equipment, and cables specified in this document. Any personnel substitutions shall be noted in writing to Owner's Data Center Operations Infrastructure

- Cabling representative prior to commencement of work.
6. BICSI ITS Cabling Installation Program Installer Level 1 or 2 or Technician certifications may be substituted in lieu of the 3-year requirement. All cabling installers shall be trained and certified by the cable manufacturer for communication cabling installations and maintenance of said materials.
  7. Refer also to General Conditions.
- C. Administrative Requirements and Coordination:
1. The Contractor shall:
    - a. Ensure that all technicians performing work have obtain badge access 48 hours prior to scheduled start.
    - b. Provide a specified contact person (name and contact number) for coordination to attend project meetings with the communication consultant, the Owner and others.
    - c. Coordinate work of this section with Owner's system specifications, workstations, equipment suppliers, and installers.
    - d. Coordinate installation work with other crafts (examples include ceiling grid contractors, HVAC and sheet metal contractors, etc.) under the direction of the General Contractor to resolve procedures and installation placement for cable trays and cable bundle pathways. The goal of this coordination will be to establish priority pathways for critical data/voice network cable infrastructure, materials, associated hardware, as well as mitigate delays to the project and to allow service access for communications and HVAC components. Damage by Contractor to the craftwork of others will be remediated at the Contractor's expense in a timely manner.
    - e. Exchange information and agree on details of equipment arrangements and installation interfaces. Record agreements reached in meetings and distribute record to other participants, Owner and communication consultant.
    - f. Arrangement, layout, and locations of distribution frames, patch panels, and cross-connect blocks in equipment rooms and racks to accommodate and optimize arrangement and space requirements of any service provider equipment, telephone system, and LAN equipment as directed by Data Center Operations. Tasks shall be coordinated with the Owner's Data Center Operations team, and other trades' installation representatives.
    - g. Where installed, confirm exact locations and method of mounting outlets in modular furniture. Follow furniture manufacturers' written instructions for installing cable and devices in modular partitions. Obtain modular furniture and power pole locations from the General Contractor. Wiring locations noted in plans along walls for modular furniture are approximate and will have to be determined by Contractor at time of installation. Field condition adjustments for installation may have to be made and coordination efforts with the mechanical and electrical contractor for pathway must take place early in the project to comply with maximum 40% conduit fill factor requirements.
    - h. When requested by Owner or Owner's representative, furnish extra materials that match specified products and that are factory packaged with protective covering for storage and identified with labels describing contents. Unit pricing shall apply.
- D. Contract Administration:
1. Change orders shall be submitted to the Owner/Project Manager complete with price breakdown and description for approval before any work is done.
  2. Owner's Data Center Operations Representative will provide job field reports upon inspection of Contractor's installation, materials, supporting hardware,

- coordination with other trades and progress to schedule to the Owner's project manager.
3. Job Field Report outline:
    - a. General installation progress in relation to scheduled work made by the Contractor up to that date.
    - b. All deficiencies noted in the cable installation to be corrected by the Contractor.
- E. Pre-Installation Meetings - Contractor shall:
1. Attend and/or arrange a scheduled pre-installation conference prior to beginning any work of this section.
    - a. Agenda: This venue is to ask and clarify questions in writing related to work to be performed, scheduling, coordination, etc. with consultant and/or project manager/and Data Center Operations Infrastructure Cabling representative.
    - b. Attendance: Communications project manager/supervisor shall attend meetings arranged by General Contractor, Owner's Data Center Operations Infrastructure Cabling representatives, and other parties affected by work of this document.
    - c. All individuals who will be installers of communication cables and equipment in an on-site supervisory capacity shall be required to attend the pre-installation conference. Individuals who do not attend the conference will not be permitted to supervise the installation of, or install, terminate, or test communications cables on the project. This includes supervisors, project managers, and lead installers of this project.
- F. Request for Change (RFC)
1. A Request for Change shall be opened and approved by the Change Approval Board prior to any modifications, attachments, or other activities that may affect production systems.
    - a. Policy and details available through the Data Center Operations Infrastructure Cable Representative.
- G. Post-Installation Meetings:
1. Schedule Div. 27 Final Inspection
  2. At the time of substantial completion, or shortly thereafter, the low voltage Sub-Contractor shall call and arrange for a post-installation meeting to present and review all submittal documents to include, but not limited to as-built drawings, test reports, warranty documentation, etc. Attendees shall be Owner staff, Owner's Representative, General Contractor, and others that the General Contractor deems appropriate.
  3. At this meeting the Contractor shall present and explain all documentation, including test results, and ask for feedback on its completeness. Any discrepancies or deviations noted by and agreed to by participants shall be remedied by Contractor and resubmitted within one week of meeting.

#### 4.2 DELIVERY, STORAGE, AND HANDLING:

- A. Coordination with delivery companies, drivers, site address, and contact person(s) will be the responsibility of the Contractor.
- B. Contractor Shall:
1. Be responsible for prompt material deliveries to meet contracted completion date.
  2. Coordinate deliveries and submittals with the General Contractor to ensure a timely installation.
  3. No equipment materials shall be delivered to the job site more than three weeks prior to the commencement of its installation.
  4. Equipment shall be delivered in original packages with labels intact and identification clearly marked.

- 5. Materials shall not be damaged in any way and shall comply with manufacturer's operating specifications.
  - 6. Equipment and components shall be protected from the weather, humidity, temperature variations, dirt, dust, or other contaminants. Equipment damaged prior to system acceptance shall be replaced at no cost to the Owner.
  - 7. Material Contractor shall be responsible for all handling and control of equipment.
  - 8. Material Contractor is liable for any material loss due to delivery and storage problems.
- C. Owner/General Contractor shall supply a list of security requirements for Contractor to follow.

4.3 PROJECT/SITE CONDITIONS

- A. For all environmental recommendations, refer to master Architectural section.
- B. For all security recommendations, refer to related Division 01.
- C. After completing system installation, including outlet fittings and devices, inspect exposed finish. Contractor will remove burrs, dirt, and construction debris. If applicable, the Contractor will repair damaged finishes, including chips, scratches, and abrasions.
- D. Contractor shall provide daily a clean work environment, free from trash/rubbish accumulated during and after cabling installation.
- E. Food and drink are not permitted in work areas. They shall be stored, prepared, and consumed only in designated break or cafeteria areas.
- F. Contractor shall keep all liquids (drinks, sodas, etc.) off finished floors, carpets, and tiles. If any liquid or other detriment (cuts, soils, stains, etc.) damages the above finishes, Contractor shall provide professional services to clean or repair scratched/soiled finishes, at Contractor's expense.

4.4 CLEANING

- A. Work areas will be kept in a broom clean condition throughout the duration of the installation process.
- B. Remove all unnecessary tools and equipment, unused materials, packing materials, and debris from each area where work has been performed daily, unless designated for storage.
- C. The Contractor will damp clean all surfaces prior to final acceptance by Owner.

END OF SECTION

## SECTION 270100

OPERATION AND MAINTENANCE OF  
COMMUNICATIONS SYSTEMS

## PART 1 - GENERAL

## 1.1 INTRODUCTION

- A. To make the approval of such a large topic possible, the structured cable topic has been broken into its subcomponents and each subcomponent was completed, reviewed, and approved in turn. The result is this comprehensive guideline that should provide adequate guidance on this topic.

## PART 2 - PRODUCT

## 2.1 KEY POINTS

- A. Category 6A shielded foil over unshielded twisted pair (F/UTP) is the only approved standard for cabling.
  - 1. Specifically, Siemon category CAT6A F/UTP (foil over unshielded twisted pair) cable and associated patch panels, wall plates and jacks; for data centers, and all clinical and hospital campus'.
  - 2. Only Siemon certified contractors or certified Intermountain Healthcare cable technicians will install structured cable at Intermountain Healthcare facilities.

## 2.2 IMPLEMENTATION

- A. This guide is to be used for New Construction and Remodels. These standards will be implemented over time in existing cabling environments as rework is performed.
- B. If there is a current need to connect servers at 10GBaseT and the only option is copper, CAT6A F/UTP is required. New Server connections shall be a minimum OS1 Single Mode Fiber.
- C. Installations already in place are not required to remove or replace existing cabling CAT5e or newer. All new cabling shall follow the recommendation to use CAT6A F/UTP cabling.

## 2.3 STANDARD PRODUCT

- A. The Approved cable type for horizontal cabling is CAT 6A F/UTP.
  - 1. The Approved Standard Manufacturer for Intermountain Healthcare's horizontal cabling is:
    - a. **Siemon Company USA**  
101 Siemon Company Drive  
Watertown, CT 06795
  - 2. Approved Suppliers of Siemon cable, patch panels, jacks, and parts are listed in Appendix 06:

## PART 3 - EXECUTION

## 3.1 Horizontal Cabling

- A. Horizontal Subsystem is the portion of the cabling system that extends from (and includes) the work area telecommunications outlet/connector to the Floor Distributor

(FD)/Horizontal Cross-connect (HC) in the telecommunications room (TDR). It consists of the communications outlet/connector, the horizontal cable, optional consolidation point,

and that portion of the cross-connect in the telecommunications room serving the horizontal cable. Each floor of a building should be served by its own Floor Distributor/Horizontal (FD/HC) Subsystem located in the telecommunications Room (TDR).

1. NOTE: Cable installers have rigorous requirements to be certified for Siemon cables and products. Validation of certification is required prior to accepting a bid.
  2. Current Siemon Approved/Certified Cable Installers for Siemon Network are listed in Appendix 07.
- B. Reliability of the horizontal cabling system is critical to the operation of IS equipment throughout a facility. Installing the cable is extremely labor intensive and there are several learned skills used to correctly install the cable. Cable installers are certified, and installers must demonstrate the ability to install the cable correctly to be certified. If the cable is installed by a certified installer and is installed in accordance with the manufacturer's guidelines, the manufacturer will warranty the cable installation.
- C. The manufacturer also requires the cables to be individually labeled and 100% tested and certified. Cable testing and certification equipment is usually expensive and is not commonly available at the facility or by many telecom installers. Certified Installer companies are required by the manufacturer to be knowledgeable in the use of "Qualified" Field Testing equipment and provide test results for warranty registration.
1. Contractor is to verify with the manufacturer the current "Qualified" tester manufacturers and the current operating software.
  2. Contractors will provide test results in the operating software format (not PDF, text or Word) to Intermountain Healthcare upon completion.
- D. Much of the cable is installed in walls and in the ceiling and usually lasts the lifespan of the building. As with most technology, the lifespan of cable is its usability and applicability to its use on future computing technology.

END OF SECTION



---

**SECTION 270113****WARRANTY, PRODUCT AND SYSTEM****PART 1 - GENERAL****1.1 RELATED DOCUMENTS**

- A. Drawings and general provisions of the Contract, including General and Supplementary Conditions and Division 01 Specification Sections, apply to this Section.
- B. Specifications throughout all Divisions of the Project Manual are directly applicable to this Section, and this Section is directly applicable to them, including but not limited to the listing found in Section 27 00 00.

**PART 2 - PRODUCTS****2.1 STANDARD WARRANTY**

- A. Contractor shall provide a minimum one (1) year warranty on installation and workmanship PLUS an Extended Product Warranty and System Assurance Warranty for this wiring system and shall commit to make available local support for the product and system during the Warranty period.
- B. System Certification: Upon successful completion of the installation and subsequent inspection, the customer shall be provided with a Manufacture Warranty certificate.
- C. Either a permanent link or channel model configuration may be applied to the horizontal and/or backbone sub-systems of the structured cabling system. Applications assurance is only applied to a channel model configuration. All channels are to be qualified for linear transmission performance up to 500 MHz to ensure that high-frequency voltage phase and magnitude contributions do not prove cumulative or adversely affect channel performance.

**2.2 EXTENDED WARRANTY**

- A. The manufacturer of passive telecommunications equipment used in a manner not associated with the Systems Warranty must have a minimum five (5) year Component Warranty on all its product. The Products Warranty covers the components against defects in material or workmanship under normal and proper use.
  - 1. Special Project Warranty: A full end-to-end written warranty mutually executed by manufacturer and the principal Installer, agreeing to replace and install voice/data distribution system components that fail in materials or workmanship, or do not meet manufacturer's official published specifications and performance criteria within the special Project warranty period specified below. This shall cover applications assurance, cable, and connecting hardware including both labor and materials. This warranty shall be in addition to, and not a limitation of, other rights and remedies the Owner may have against the Contractor under the Contract Documents.
- B. A twenty (20) year warranty available for the Category 6A Z-MAX copper structured cabling system shall be provided for an end-to-end channel model installation which covers applications assurance, cable, connecting hardware and the labor cost for the repair or replacement thereof. The fiber warranty will be an XGLO twenty (20) year warranty, which is based on using laser optimized single mode fiber as minimum.
  - 1. Performance claims based on worst case testing and channel configurations.

2. Special Project Warranty Period: 20 years minimum, beginning on the date of Substantial Completion.
3. Siemon Certified Warranty Requirements:
  - a. Upon Completion of the project, Intermountain Healthcare must receive the Full Warranty Documentation from The Siemon Company before final retention funds are released to the general contractor, electrical contractor and structured cabling subcontractor if applicable.

### 2.3 MAINTENANCE

- A. Support Availability: The Contractor shall commit to make available local support for the product and system during the Warranty or Extended Warranty period.

END OF SECTION

## SECTION 270119

## FIELD TESTING AND REPORTING

## PART 1 - GENERAL

## 1.1 RELATED DOCUMENTS

- A. Drawings and general provisions of the Contract, including General and Supplementary Conditions and Division 01 Specification Sections, apply to this Section.
- B. Specifications throughout all Divisions of the Project Manual are directly applicable to this Section, and this Section is directly applicable to them, including but not limited to the listing found in Section 27 00 00.

## 1.2 SYSTEM DESCRIPTION

- A. Owner reserves the right to be present during any or all testing.
- B. The objective of this project is to provide a complete communications cabling infrastructure system installation including, but not limited to: fiber backbone, riser system, horizontal data and voice cabling with associated terminations, mounting equipment, cable pathway and management systems, testing and other items/materials, as specified in drawings, these specifications, and contract documents.
- C. The Contractor's BICSI Registered Communications Distribution Designer (RCDD) supervisor shall review, approve and stamp all documents prior to submitting. The Contractor's RCDD shall warrant in writing that 100% of the installation meets the requirements specified herein upon completion of all work.
- D. Product Certificates shall be signed by manufacturers of cables, connectors, and terminal equipment certifying that products furnished comply with requirements.
- E. Contractor shall submit the required Field Test Reports in the format and media specified, upon completion of testing the installed system.
- F. Contractor shall deliver manufacturer's signed long-term Warranty of installed cabling system to include all components that comprise the complete cabling system. Delivery to be affected within two weeks of the time of final punch list review. Failure of any component to pass system component tests shall be promptly corrected, repaired or replaced to meet standards compliance.

## 1.3 PREFERRED OWNER INSPECTION &amp; TEST CHECKPOINTS

- A. DCO & ICT Inspection Milestones & Responsibilities need to be coordinated into master project plan to allow the GC to make timely arrangements. All are per floor and/or phase.
  - 1. ICT & DCO = Framing, during and/or after boxes & conduits are in place; prior to sheetrock.
  - 2. ICT = When cable basket is starting to be installed.
  - 3. ICT = When cable basket is ready, but prior to starting to pull cable.
  - 4. ICT & DCO = When TDR's are ready for racks and ladders.
  - 5. DCO = When anchoring racks and laying out equipment.
  - 6. ICT & DCO = When TDR environmental requirements are ready, room is dust free, and securable.
    - a. The TEC and TDRs must be high on the build timeline and be completed early in the construction to accommodate the building systems to be tested and commissioned, such as BAS, Security, and Wireless Network.
  - 7. ICT = When trim and testing are in progress.
  - 8. OTHERS
    - a. Depending on project, the manufacturer will inspect 1 or 2 times.

- b. DCO or ICT = When problems or questions arise.

## PART 2 - PRODUCTS

### 2.1 SITE TESTS & INSPECTIONS

- A. Prior to pulling cable, the cabling contractor shall schedule an inspection of the pathways with a member of the Data Center Operations Infrastructure cabling team.
- B. Upon completion of the communications infrastructure systems, including all pathways and grounding, the Contractor shall test the system.
  - 1. Cables and termination modules shall be affixed, mounted or installed to the designed/specified permanent location prior to testing.
  - 2. Any removal and reinstallation of any component in a circuit, including faceplates, shall require retesting of that circuit and any other disturbed or affected circuits.
  - 3. Approved instruments, apparatus, services, and qualified personnel shall be utilized.
  - 4. If tests fail, Contractor shall correct as required to produce a legitimate passing test.
  - 5. Manipulation of tester parameters on a failing test in order to achieve a passing test is unacceptable.
- C. These specifications will be strictly enforced. The Contractor must verify that the requirements of the specifications are fully met through testing with an approved tester (rated for testing the cable type in use), and documentation as specified below. This includes confirmation of requirements by demonstration, testing and inspection. Demonstration shall be provided at final walk-through in soft copy.
- D. Notification of the likelihood of a cable exceeding standardized lengths must be made prior to installation of the cable. Without contractor's prior written notice and written approval by the Owner, testing that shows some or all pairs of cable not meeting specifications, shall be replaced at Contractor's expense (including respective connectors).
- E. Testing is still required for non-compliant cabling. The tests shall be for wire-mapping, opens, cable-pair shorts, and shorts-to-ground. The test results must be within acceptable tolerances and shall be submitted with the Owner's acceptance document.

### 2.2 CABLE TESTING PLAN

- A. The Contractor shall:
  - 1. Provide a complete and detailed test plan for approval of the cabling system specified herein, including a complete list of test equipment for copper and fiber optic components and accessories prior to beginning cable testing. The following minimal items shall be submitted for review:
    - a. All testing methods that clearly describes procedures and methods.
    - b. Product data for test equipment
    - c. Certifications and qualifications of all persons conducting the testing.
    - d. Calibration certificates indicating that equipment calibration meets National Institute of Standards and Technology (NIST) standards and has been calibrated at least once in the previous year of the testing date.
  - 2. Include validation, and testing. Owner will require that the telecommunications cabling system installed by the Contractor be fully certified to meet all necessary requirements to be compliant with referenced IEEE and TIA specifications and vendor's warranty.
  - 3. Will determine the source/cause of test failure readings and correct malfunctioning component and/or workmanship within each channel or permanent link and retest to demonstrate compliance until corrected failure produces a passing result.

## 2.3 CABLE TESTING REPORTS

- A. The Contractor shall submit cable test reports as follows:
  - 1. Submit certified test reports of Contractor-performed tests.
    - a. The tests shall clearly demonstrate that the media and its components fully comply with the requirements specified herein.
    - b. (1) set of electronic test reports shall be submitted and clearly identified with cable identification.

## PART 3 - EXECUTION

### 3.1 TEST EQUIPMENT

- A. All transmission testing of balanced twisted-pair cables shall be performed with an approved Level III balance twisted pair tester found on the Siemon Ally Website. The latest version of software shall be installed prior to performing testing. Refer to the Siemon Warranty Documents for proper testing requirements of associated cable and components.
- B. All balanced twisted-pair field testers shall be factory calibrated each calendar year by the field test equipment manufacturer as stipulated by the manuals provided with the field test unit. The calibration certificate shall be provided for review prior to the start of testing
- C. Auto test settings provided in the field tester for testing the installed cabling shall be set to the default parameters
- D. Test settings selected from options provided in the field testers shall be compatible with the installed cable under test.

### 3.2 TEST METHOD / CRITERIA

- A. Copper Testing
  - 1. Testing of all newly installed cable channels shall be performed prior to system cutover.
    - a. Visually inspect F/UTP and optical fiber cable jacket materials for NRTL certification markings. Inspect cabling terminations in communications equipment rooms for compliance with color-coding for pin assignments and inspect cabling connections for compliance with TIA/EIA-568-C.1.
    - b. Visually confirm Category 6A marking of outlets, cover plates, outlet/connectors, and patch panels.
    - c. Visually inspect cable placement, cable termination, grounding and bonding, equipment and patch cords, and labeling of all components.
    - d. Test F/UTP copper cabling for DC loop resistance, shorts, opens, intermittent faults, and polarity between conductors. Test operation of shorting bars in connection blocks. Test cables after termination but not cross-connection.
    - e. Test instruments shall meet or exceed applicable requirements in TIA/EIA-568-C, and those required by manufacturer to validate and start warranty.
  - 2. Copper Testing all 500 MHz category 6A field-testing shall be performed with an approved level 111e balanced twisted-pair field test device, that complies with performance requirements in "Test Instruments (Normative)" Annex, complying with measurement accuracy specified in "Measurement Accuracy (Informative)" Annex (Level IIe or IIIe balanced twisted pair field test device). Use only test cords and adapters that are qualified by test equipment manufacturer for channel or link test configuration.
  - 3. All installed 500 MHz category 6A channels shall perform equal to or better than the minimum requirements as specified below:

- a. Category 3, balanced twisted-pair backbone cables, for the channel shall be 100 percent tested according to ANSI/TIA/EIA-568-C.1. Test parameters include wire map plus F/UTP (ScTP) shield continuity (when present), insertion loss, length and NEXT loss (pair-to-pair). NEXT testing shall be done in both directions.
- b. 500 MHZ Category 6A balanced twisted-pair horizontal and backbone cables, shall be 100 percent tested.
4. F/UTP Performance Tests
  - a. Wire map.
  - b. Length (physical vs. electrical, and length requirements)
  - c. Insertion loss
  - d. Near-end crosstalk (NEXT) loss
  - e. Power sum near-end crosstalk (PSNEXT) loss
  - f. Equal-level far-end crosstalk (ELFEXT)
  - g. Power sum equal-level far-end crosstalk (PSELFEXT)
  - h. Return loss
  - i. Propagation delay
  - j. Delay skew
  - k. F/UTP Shield continuity
5. Final Verification Tests: Perform verification tests for F/UTP systems after the complete communications cabling and workstation outlet/connectors are installed.
6. Document data for each measurement. Data for submittals shall be printed in a summary report.
7. End-to-end cabling will be considered defective if it does not pass tests and inspections.
8. Prepare and submit test and inspection reports.
- B. Horizontal Fiber Testing
  1. Fiber horizontal cables shall be 100% tested for insertion loss and length.
  2. Insertion loss shall be tested at 850 nm or 1300 nm for 50/125 $\mu$ m and 62.5/125 $\mu$ m multimode cabling in at least one direction using the Method B (1-jumper) test procedure as specified in ANSI/TIA/EIA-526-14A.
  3. Length shall be tested using an OTDR, optical length test measurement device or sequential cable measurement markings.
  4. The horizontal link performance guarantees are based on an optical fiber calculation for the appropriate fiber solution. Optical fiber calculations shall be determined using the Siemon Fiber Loss Calculator found on the Siemon Ally Website.
- C. Backbone Fiber Testing
  1. Fiber backbone cables shall be 100% tested for insertion loss.
  2. Insertion loss shall be tested at both 850 nm and 1300 nm for 50/125 $\mu$ m and 62.5/125 $\mu$ m multimode cabling and both 1310 nm and 1550 nm for 8.5/125 $\mu$ m single mode cabling and in at least one direction using the Method B (1-jumper) test procedure as specified in ANSI/TIA/EIA-526-14A.
  3. Insertion loss shall be tested at 1310 and 1550 for single-mode cabling in at least one direction using the Method A.1 (1-jumper) test procedure as specified in ANSI/TIA/EIA-526-7.
  4. Length shall be tested using an OTDR, optical length test measurement device or sequential cable measurement markings.
  5. The backbone link performance guarantees are based on an optical fiber calculation for the appropriate fiber solution. Optical fiber calculations for any fiber cable greater than 90m (295 ft.) shall be determined using the Siemon Fiber Loss Calculator found on the Siemon Ally Website.

### 3.3 DEMONSTRATION

- A. Include training for appropriate IT staff in numbering system and documentation system methods and record keeping. Proper fiber terminations and fiber jumper installations.

END OF SECTION

---

**SECTION 270133****SHOP DRAWINGS, PRODUCT DATA, SAMPLES  
DESIGN RECORDS & EXISTING CONDITIONS****PART 1 - SHOP DRAWINGS, PRODUCT DATA, AND SAMPLES****1.1 SUBMITTALS**

- A. The Contractor:
  - 1. Shall not perform any portion of the work requiring submittal and review of shop drawings, product data, or samples until Owner has approved the respective submittal. Such work shall be in accordance with approved submittals.
    - a. Shop drawings as required by the owner or as a minimum to include a minimum of two sets of a plan view and elevations of all work to be installed. The Contractor shall make any corrections required by the owner or the owner's representative or consultant team, file with him two corrected copies and furnish such other copies as may be needed. The consultant's approval of such drawings or schedules shall not relieve the Contractor from responsibility for deviations from drawings or specifications, unless he has in writing and called to the Architect's attention such deviations at the time of submission, nor shall it relieve him from responsibility for errors of any sort in shop drawings or schedules.
- B. The Contractor shall provide a copy of the Certified Test Data Sheet, available from the delivering distribution warehouse for either a full run or cut piece from the Master Reel of the fiber cable to be installed
  - 1. The Certified Test Data Sheet shall include the Master Reel number, cable description, a passing test result with details, test equipment description, date certified, and a certificate of compliance stamp, and shall be included in the O&M Manual as a component of the final deliverables submittal package.

**1.2 DRAWINGS**

- A. Shop Drawings
  - 1. The Contractor shall:
    - a. Submit catalogue cut sheets that include manufacturer, trade name, and complete model number for each product specified. Model number shall be handwritten, marked with an arrow or underlined to indicate exact selection.
    - b. Identify applicable specification section reference for each product performance for each component specified for approval prior to purchase and installation.
- B. Record Drawings
  - 1. Drawings for the cabling system infrastructure elements shall be maintained and kept on file by the Siemon Certified Installer (Company) for the entire term of the warranty. Drawings shall include:
    - a. Horizontal cable routing and terminations
    - b. Telecommunications outlets/connectors
    - c. Backbone cable routing and terminations
    - d. Telecommunication Spaces (TS)
- C. Samples



1. For workstation outlet connectors, jack assemblies, housing and faceplates for color selection and evaluation of technical specifications and requirements. Confirm with Architect, interior designer, and Owner representative for color before purchasing materials. Face plates shall match the electrical face plates in Color and material type.
  2. Upon request, provide samples for workstation outlets, jacks, jack assemblies, in specified finish, one for each size and outlet configuration
  3. Sample mock-up rooms may be required in some areas to ensure proper equipment placement and fit.
- D. Qualifications:
1. The Contractor shall provide the appropriate documentation to comply with the requirements set forth in Section 01 43 23 Qualifications, included with, and at the time of, bid submittal.

## PART 2 - SUSTAINABLE DESIGN RECORDS AND REPORTS

### 2.1 DRAWINGS

- A. Closeout Submittals (As-built Drawings):
1. Communications Design drawings are to be supplied to the Architect to prepare the master "As-Built" drawings.
  2. As-Built drawings shall be in a format that is compatible with the format used by the Architect and consultant. Dimensions and scale of the drawing sheets submitted shall match the size of the drawing used for the contract documents and shall include the cable numbers labeled in accordance with this document.
  3. Utilize normal recognized drafting procedures that match standards, Architect and consultant guidelines and methodology.
  4. The As-Built drawings shall incorporate all changes made to the building identified in, but not limited to, addendum, change notices, site instructions or deviations resulting from site conditions.
- B. Contractor shall:
1. Clearly identify any resubmitted drawing sheets, documents or cut sheets either by using a color to highlight or cloud around resubmitted information.
  2. Maintain drawing numbering or page/sheet scheme consistency as per previously issued drawings/documents.
  3. Provide dimensioned plan and elevation views of networking components, showing:
    - a. All communications data/voice outlet locations complete with outlet/cable labeling.
    - b. Cable routing paths of communications cables to identified infrastructure pathways.
    - c. All rack and cabinet locations and labeling thereof.
    - d. One-line diagram of equipment/device interconnecting data/voice cabling of the data and voice systems.
    - e. Standard or typical installation details of installations unique to Owner's requirements.
    - f. Graphic symbols and component identification on detail drawing shall conform to the latest ANSI/TIA 568-C, ANSI/TIA 569-B, ANSI/TIA 606-A and ANSI/NECA/BICSI 607-A conventions.
  4. Submit one soft (compatible with Microsoft software) and hard copy with project deliverables within three weeks subsequent to substantial completion.
  5. Hard copy of floor plans for record shall be plotted to a standard, saleable, identified drawing scale.

### 2.2 RECORDS AND REPORTS

- A. All records shall be created by the installation contractor and turned over at the completion of work.
  - 1. The format shall be computer based
    - a. Soft copies and hard copies shall be part of the As-built package.
    - b. The minimum requirements include:
      - 1) Cable records must contain the identifier, cable type, termination positions at both ends, splice information as well as any damaged pairs/conductors.
      - 2) Connecting hardware and connecting hardware position records must contain the identifier, type, damaged position numbers, and references to the cable identifier attached to it.
  - 2. Test documentation on all cable types shall be included as part of the As-built package.
- B. All Siemon Warranty Registration documents shall be included.
- C. All reports shall be generated from the computer-based program used to create the records above. These reports should include but not limited to:
  - 1. Cable Reports
  - 2. Cross-connect Reports
  - 3. Connecting Hardware Reports

### PART 3 - EXISTING CONDITIONS SITE SURVEY

#### 3.1 SITE SURVEY

- A. Prior to placing any cable pathways or cable, the contractor shall survey the site to determine job conditions will not impose any obstructions that would interfere with
- B. the safe and satisfactory placement of the cables. The arrangements to remove any obstructions with the Project Manager need to be determined at that time.

END OF SECTION

## SECTION 270143

QUALIFICATIONS AND REQUIRED TRAINING  
FOR CONTRACTORS AND INSTALLERS

## PART 1 - GENERAL INSTALLER QUALIFICATIONS

## 1.1 ENTITIES

- A. Communications contractors
1. The Communications Contractor shall at a minimum possess the following qualifications:
    - a. Contractor shall be a Siemon Certified Contractor with valid up to date contract certification and in good standing with the Siemon Company.
    - b. Be in business a minimum of five (5) years.
    - c. Contractor shall demonstrate satisfaction of sound financial condition and can be adequately bonded and insured if the project deems necessary.
    - d. Possess those licenses/permits required to perform telecommunications installations in the specified jurisdiction.
    - e. Use personnel knowledgeable in local, state, province and national codes and regulations. All work shall comply with the latest revision of the codes or regulations. When conflict exists between local or national codes or regulations, the most stringent codes or regulations shall be followed.
  2. Contractor must possess current liability and workers compensation insurance certificates.
  3. Contractor must be registered with BICSI and have at least one RCDD on staff or ITS Cabling Installer Program Technician certification and Installer Level 1 & 2 for a minimum of 75 percent of staff.

## 1.2 TRAINING

- A. The Contractor shall be fully conversant and capable in the cabling of low voltage applications such as, but not limited to data, voice and imaging network systems. The Contractor shall at a minimum possess the following qualifications:
1. Personnel trained and certified in the design of the Siemon Cabling System®.
  2. Personnel trained and certified to install the Siemon Cabling System®.
  3. The Designer and Installer shall show proof of current certification of the Siemon Cabling System® via an updated certificate given after attending the Certified Installer training course or an on-line re-certification class given every two years.
  4. Provide references of the type of installation provided in this specification.
  5. Personnel trained and certified in the installation of copper cable and in the use of Level IIIe Copper Transmission Performance testers, fiber optic cabling, splicing, termination and testing techniques. Personnel must have experience using an optical light source and power meter plus an OTDR.
  6. Personnel trained in the installation of pathways and supports for housing horizontal and backbone cabling.
- B. Facilities Orientation

END OF SECTION

## SECTION 270171

RESPONSIBILITY AND WORKMANSHIP  
OF CONTRACTOR

## PART 1 - GENERAL

## 1.1 CONTRACTOR RESPONSIBILITY

- A. Contractor shall be obligated to exercise the highest standard of care in performing its obligations as defined in a request for proposal. All work shall be done in a workman like fashion of the highest standards in the telecommunications industry.
- B. All equipment and materials are to be installed in a neat and secure manner, while cables are to be properly dressed in accordance with standards recommendation for a specific type of media (i.e. UTP vs. F/UTP @ 10 Gigabit)
- C. Workers must clean any debris and trash at the close of each job and workday.
- D. Contractor acknowledges that Intermountain Healthcare will rely on contractor's expertise, ability and knowledge of the system being proposed and shall be obligated to exercise the highest standard of care in performing contractual obligation as defined in the Scope of Work.
- E. Contractor must submit The Siemon warranty, Cable Records, As Built Drawings and Test Results at the completion of work. Note: Intermountain Healthcare reserves the right to withhold final payments until all registration documents are approved by the Siemon Company and received by Intermountain Healthcare.

## 1.2 CONTRACTOR AND EMPLOYEE RESPONSIBILITY

- A. Contractors, their employees, and installers will attend annually Intermountain Healthcare required Infection Control training.
- B. Contractors, their employees, and installers will complete Reprax registration.
- C. Contractors, their employees, and installers will attend Intermountain Healthcare required site and job specific orientation.
- D. Contractors, their employees, and installers will maintain Intermountain Healthcare required immunizations.
- E. Contractors, their employees, and installers will keep their Intermountain Healthcare required confidentiality agreements current.
- F. Contractors, their employees, and installers always agree to follow all Intermountain Healthcare Policies and procedures and wear the appropriate ID while on any of Intermountain properties.
- G. Contractor will determine with Owner the appropriate level of Environmental Containment precautions to utilize for each work location. Infection Control Risk Assessments and permits will be performed as required.
- H. Upon request, provide qualification data for all qualified layout technicians, installation supervisors, and field inspector
  - 1. Siemon issued qualification badges shall be readily available for this purpose.

## 1.3 EXAMINATION

- A. Field Measurements: Verify dimensions in areas of installation by field measurements before fabrication and indicate measurements on shop drawings. Coordinate fabrication schedule with construction progress to avoid delaying the work.
- B. Established Dimensions: Where field measurements cannot be made without delaying the work, establish dimensions and proceed with fabricating units without field

measurements. Coordinate supports, adjacent construction, and fixture locations to ensure actual dimensions correspond to established dimensions.

#### 1.4 PREPARATION

- A. Pre-installation inspection
  - 1. The Contractor shall visually inspect all cables, cable reels, and shipping cartons to detect possible cable damage incurred during shipping and transport. Visibly damaged goods are not acceptable and shall be replaced by the contractor at no additional cost to the Owner.

#### 1.5 MISCELLANEOUS CONTRACTOR RESPONSIBILITIES

- A. Contractor will maintain unobstructed egress in work areas.
- B. Contractor will keep an access for all Emergency Services.
- C. Contractor will maintain training for Personnel in alternate exits if needed.
- D. Contractor will maintain Temporary construction partitions, as required, that are smoke tight and built of non-combustible materials.
- E. Additional Fire Extinguishers may be required and will be properly maintained and inspected.
- F. Construction site will be maintained clean and orderly.
- G. Contractor will observe Intermountain Healthcare's Tobacco Use Policy. (All forms of tobacco use are strictly prohibited)
- H. All Electrical Extension cords will be grounded, and in good condition and, plugged into approved GFI Receptacles.
- I. Construction site will be restricted. (Approved personnel Only)
- J. Required Personal Protective Equipment (PPE) will be worn as required. (i.e. hard hats, safety glasses, safety shoes, fluorescent vest, in accordance with general contractor's safety policy)
- K. Tools will be unplugged, and power secured at the end of each working day.
- L. All employees and contractors will understand how to obtain MSDS sheets.
- M. Contractor will notify proper personnel of any fire system shut down. A 48-hour notification is required.
- N. Contractor will address all vibration concerns with Intermountain Healthcare and general contractor's staff.
- O. Contractor will address all Noise Issues with Intermountain Healthcare and general contractor's staff.
- P. Contractor will fill out a Hot Work permit and keep it on site daily as needed.
- Q. Contractor will fill out an Above Ceiling Work Permit and keep it on site daily as needed.
- R. Contractor will obtain a Confined Space Permit, when required, and keep it on site.
- S. Contractor shall notify Information Systems 72 hours in advance of any shutdown or known interruption of required environmental services. Follow up by notifying the Service Desk.
- T. Demolition of low voltage cabling shall be performed by the Low Voltage installation contractor.
  - 1. To prevent accidental removal of in-use circuits.
  - 2. To allow for re-use of circuits where practical.

END OF SECTION

## SECTION 270500

COMMON WORK RESULTS  
FOR COMMUNICATIONS

## PART 1 - PRODUCT

## 1.1 SUMMARY

- A. This section covers general work results for all Communications Division detail subsections.
- B. Work of the following sections cover a complete installation of both permanent and channel links for a data and voice communications network utilizing copper and fiber transmission media.

## PART 2 - EXECUTION

## 2.1 SCOPE OF WORK

- A. Includes, but is not limited to the following.
  - 1. The Contractor shall:
    - a. Provide and install fabric and/or either plenum, PE or PVC Innerduct, rated appropriately for the installation environment; in accordance with all applicable codes and ordinances.
    - b. Provide, install, terminate, test, label and document all fiber backbone, fiber and copper riser cable.
    - c. Provide, install, terminate, test, and document all fiber, copper voice, and data horizontal cable.
      - 1) CAT6A UTP and CAT6A F/UTP shall not be mixed on the same campus.
    - d. Provide and place all termination devices such as, but not limited to, modular patch panels, termination blocks, information outlets (jacks and plates), phone jacks, fiber distribution panels, bulkheads, connectors, and fiber fan out kits.
    - e. Provide in quantities specified interconnect components such as, but not limited to, copper patch cords, fiber patch cables and data station cables.
    - f. Provide and place horizontal and vertical cable support devices such as, but not limited to, rack and wall-mounted horizontal and vertical cable management, cable runway, communications cable runway, and all required mounting hardware, unless otherwise noted.
    - g. Provide and install all equipment mounting racks, cabinets and/or brackets.
    - h. Provide and install UL-approved fire stopping systems in all communication pass-thru, conduits, cable trays and ceiling, wall and floor penetrations in coordination with General Contractor.
    - i. Provide all appropriate consumable items required to complete the installation.
    - j. Grounding and bonding in TEC and TR rooms to grounding bus provided by Division 26.
    - k. Provide complete documentation and demonstration of work.
    - l. Completion of all punch list deficiencies within 10 working days.
    - m. Provide indexed and organized complete Test Results of all copper and fiber cable and their components.
    - n. Provide Submittals.

- o. Conduct a final document handover meeting with client, consultant, and PM to review, discuss and educate the Owner on the test results and As-Built Drawings.
- p. Provide a Manufacturer's Extended Product Warranty and System Assurance Warranty for this wiring system.

END OF SECTION

## SECTION 270526

GROUNDING AND BONDING FOR  
COMMUNICATIONS SYSTEMS

## PART 1 - GENERAL

## 1.1 RELATED DOCUMENTS

- A. This work shall be provided by Division 26.
  - 1. Division 26 shall provide and install the communications system grounding bus bar.
  - 2. Systems other than the voice/data system shall be bonded by their respective installers or Division 26.
- B. Exception: Division 27 shall bond racks, ladders, and other conductive IT equipment and enclosures as required.
- C. Requirements of the following Division 26 Sections apply to this section:
  - 1. Basic Electrical Requirements
  - 2. Basic Electrical Materials and Methods
  - 3. Grounding and Bonding for Electrical Systems

## 1.2 SUMMARY

- A. This Section includes methods and materials for grounding and bonding Communications systems.
- B. All grounding / earthing and bonding shall be done to applicable codes and regulations. It is recommended that the requirements of IEC/TR 61000-5-2: 1.0, ANSI-J-STD-607-A, or both be observed throughout the entire cabling system.

## PART 2 - PRODUCTS

## 2.1 CONDUCTORS

- A. Insulated Conductors: Copper wire or cable insulated for 600 V unless otherwise required by applicable Code or authorities having jurisdiction.
  - 1. Stranded conductors No. 6 AWG.

## 2.2 CONNECTORS

- A. Listed and labeled by a nationally recognized testing laboratory acceptable to authorities having jurisdiction for applications in which used, and for specific types, sizes, and combinations of conductors and other items connected.
- B. Compression fitting – 2-hole strap.

## PART 3 - EXECUTION

## 3.1 QUALITY ASSURANCE

- A. Electrical Components, Devices, and Accessories: Listed and labeled as defined in NFPA 70 (NEC), Article 100, by a testing agency acceptable to authorities having jurisdiction, and marked for intended use.
- B. Comply with UL 467 for grounding and bonding materials and equipment.

## 3.2 APPLICATIONS



- A. Conductors: Install stranded conductors for No. 6 AWG and larger, unless otherwise indicated.

### 3.3 INSTALLATION

- A. Grounding Conductors
  - 1. Route along shortest and straightest paths possible, unless otherwise indicated or required by Code.
  - 2. Avoid obstructing access or placing conductors where they may be subjected to strain, impact, or damage.
    - a. Jumper across all tray junctions use two-hole crimp lugs with a bolt, lock washer and nut to prevent loosening of ground connections over time.
    - b. Contractor to remove small area of powder coat or paint to create a metal to metal bonding connection.
    - c. Per current BICSI TDMM "Grounding, Bonding and Electrical Protection":
      - 1) Grounding and bonding connectors should be one of the following: Tin plated copper, copper or copper alloy
      - 2) Connections should be made using crimp connectors, or exothermic welding.
    - d. Per TIA/EIA 607-A the TBB (Telecommunications Bonding Backbone) connections "shall be made using irreversible compression-type connectors, exothermic welding or equivalent."

END OF SECTION

## SECTION 270528

## PATHWAYS FOR COMMUNICATONS SYSTEMS

## PART 1 - GENERAL

## 1.1 RELATED DOCUMENTS

- A. Main pathways for communications systems shall be the responsibility of the Division 27 low voltage contract.
  - 1. Includes, but is not limited to, hangars, supports, J-hooks and cable tray.
  - 2. Sections 270536, 270539, and 270543\_46, are supplemental clarifications that are additions to this section. The appropriate section(s) shall add for the material used.
- B. Conduits, pathways, and boxes which are embedded within building finishes for communications systems shall be the responsibility of the Division 26 electrical contractor
- C. Requirements of the following Division 26 sections apply to this section
  - 1. Basic electrical requirements
  - 2. Basic electrical materials and methods
  - 3. Grounding, earthing, and bonding for electrical systems

## 1.2 SUMMARY

- A. Contractor shall install work following specifications, drawings, manufacturer's instructions and approved submittal data.

## PART 2 - PRODUCTS

## 2.1 CABLE PATHWAYS

- A. Comply with TIA/EIA-569-B.
- B. Pathways shall be designed and installed to meet applicable local and national building and electrical codes or regulations.
  - 1. All materials shall be UL- and/or CSA and/or ETL-approved and labeled in accordance with NEC for all products where labeling service normally applies.
  - 2. NRTL labeled for support of Category 6A cabling, designed to prevent degradation of cable performance and pinch points that could damage cable
  - 3. Materials and equipment requiring UL 94, 149 or 1863 listing shall be so labeled. Modification of products that nullifies UL labels are not permitted.
  - 4. The installed systems shall not generate, nor be susceptible to any harmful electromagnetic emission, radiation, or induction that degrades, or obstructs any equipment.
- C. Pathways consist of conduit, basket tray/ladder rack, J-hooks, surface mounted raceway and power poles.
  - 1. Basket tray shall be utilized for distribution pathways
    - a. Provides proper support and load distribution along pathways.
    - b. Flexibility, scalability, and accessibility
    - c. Ladder rack shall be used in data rooms.
  - 2. Conduits may be utilized where cable tray is not viable, providing the cross-sectional area of the conduit is greater than the cross-sectional area of the cable tray.
  - 3. J-hooks are the minimum pathway device required for all low voltage contractors for use in ceiling distribution.
    - a. Refer to section 270529.

4. Note: Surface mounted raceway and power poles should be installed only when other pathway choices are not feasible.

## 2.2 EQUIPMENT

- A. Compatibility
  1. All material and equipment as provided should be the standard Commercial-Off-The-Shelf (COTS) products of a manufacturer engaged in the manufacturing of such products. All shall be typical commercial designs that comply with the requirements specified. All material and equipment shall be readily available through manufacturers and/or distributors.
    - a. All equipment shall be standard catalogued items of the manufacturer and shall be supplied complete with any optional items required for proper installation.
    - b. Coordinate the features of materials and equipment so they form an integrated system. Match components and interconnections for optimum future performance and backward compatibility
- B. Horizontal cables shall be installed in "clean, dry" locations that provide protection from moisture levels above the intended operating range of inside plant (ISP) cables
  1. Cable pathways shall be installed to provide protection from the elements (i.e. moisture) and other hazards.
  2. Cables and cable pathways shall be protected from detritus elements such as paints, adhesives, water and cleaners.
    - a. In case of contamination, cables shall be replaced at the General Contractors expense. Cleaning is not acceptable.
  3. Pathways shall not have exposed sharp edges that may come into contact with telecommunications cables.
- C. Pathways shall not be in elevator shafts.
- D. Grounding / Earthing and bonding of pathways shall comply with applicable codes and regulations. It is recommended that the requirements of IEC/TR3 61000-5-2 - Ed. 1.0, ANSI-J-STD-607-B, or both be observed throughout the entire cabling system.

## 2.3 SURFACE MOUNTING

- A. Surface Mount Cable Runs and Faceplate Boxes
  1. Surface mounting of cable pathway runs and/or boxes for outlets/faceplates are only authorized as a last resort and exception to running cables through the wall and above the ceiling.
  2. If surface mount cable runs are used:
    - a. Burrs will be removed from the inside of the plastic or metal surface mount pathway to prevent damage to cables pulled through the run.
    - b. Raceway manufacturer plastic bushings shall be installed at all outlet openings in raceway to prevent damage to cable.
    - c. "T", Splice, and corner pieces will be used to join runs. Runs will not be butted together without the appropriate joining pieces.

## PART 3 - EXECUTION

### 3.1 HORIZONTAL PARAMETERS

- A. Allowable Cable Bend Radius and Pull Tension:
  1. In general, communications cable cannot tolerate sharp bends or excessive pull tension during installation.
    - a. Bend radius for 4 pair UTP and F/UTP under no load (no pulling tension) shall not exceed four (4) times the outside diameter of the cable and

eight (8) times the outside diameter of the cable under load (110N/25lbf).  
Note: Cable bend radius and pulling tensions for cables other than 4 pair

cable increase with the diameter and type of cable refer to the manufacturer's recommendations for specific requirements.

2. After installation, exposed cable and other surfaces must be cleaned free of lubricant residue. Use only lubricants specifically designed for cable installation.
- B. Pull Strings:
1. Horizontal and Vertical Pathways
    - a. The pathway installer shall:
      - 1) Provide pull strings in all new conduits, including all conduits with cable installed as part of this contract.
      - 2) Provide pull strings in all new cable trays.
      - 3) Pull string shall have a rated average breaking strength of 200 pounds.
      - 4) During pulling sessions, pull strings must move freely to prevent cable jacket/cable damage.
      - 5) Free moving pull strings shall be provided in all locations where they are utilized as part of this contract.
- C. Conduit Fill:
1. Reference manufacturer's Design Installation Guidelines manual.
  2. Comply with requirements of NFPA 70 (NEC)
  3. The number of cables placed in a pathway shall not exceed manufacture specifications, nor, will the geometric shape of a cable be affected.
    - a. Conduit pathways shall have a maximum fill ratio of 40% to allow for proper pulling tension and lay of the CAT6A F/UTP cable. A minimum of a 1" diameter conduit is required for new construction. Existing conduits will require the reduction of the number of cables placed in the conduit to meet the required fill ratio.

### 3.2 INTRA-BUILDING CABLE ROUTING

- A. Pathways
1. The backbone subsystem shall include cable installed in a vertical manner between floor telecommunications rooms and the main or intermediate cross-connect in a multi-story building and cable installed horizontally between telecommunications rooms and the main or intermediate cross-connect in a long single-story building.
  2. Adequate riser sleeve/slot space shall be available with the ability to ingress the area later in all telecommunications rooms, such that no drilling of additional sleeves/slots is necessary. Proper fire stopping is required for all sleeves/slots per national and local codes. Install fire stop material designed specifically for the building construction conditions and to meet the existing fire stop material as directed by the building engineer.
  3. Backbone pathways shall be installed or selected such that the minimum bend radius of backbone cables is kept within manufacturer specifications both during and after installation.
  4. Where redundant paths are required, they shall be separated by a minimum of 24".
    - a. Separate innerducts and/or armored fiber are required for each leg of the redundant path.
    - b. Separate physical routing for each path shall be utilized where possible.
  5. Building backbone cables shall be installed in "dry" locations that provide protection from moisture levels above the intended operating range of inside plant (ISP) cables. "Slab-on-Grade" building designs wherein pathways are installed underground on/in the poured concrete slabs that are in direct contact with the soil are considered wet locations and hence are not permitted.

END OF SECTION

---

**SECTION 270529****HANGERS AND SUPPORTS FOR  
COMMUNICATION SYSTEMS****PART 1 - PRODUCTS****1.1 APPROVED PRODUCT**

- A. The J-hooks shall meet or exceed the below characteristics of construction and features
  - 1. Provide broad based support for cabling to aid in maintaining overall system performance.
  - 2. Be available in 50.8mm (2") and 101.6mm (4") options
  - 3. Come equipped with a cable retention clip
  - 4. Offers a full line of mounting accessories.

**1.2 APPROVED MANUFACTURERS**

- A. Ericson / Caddy
- B. B-Line
- C. Stiffy

**PART 2 - EXECUTION****2.1 J-HOOKS AND OTHER SUPPORTS SHALL BE INSTALLED SUCH THAT THEY:**

- A. Shall be supported with devices designed for this purpose and shall be installed independently of any other structural component. J-Hooks shall not use the suspended ceiling support wires or lighting fixture support wires.
- B. The number of cables placed into the J-hooks shall be limited to a number that will not cause a change to the geometric shape of the cables.
  - 1. Limit to a 40% fill in new construction.
- C. J-hooks shall not be spaced farther than 1.5 meters (5 ft.) apart, with a recommendation that they be spaced at 1 meter (3 ft.) apart. Note: Construction may require distances to exceed the maximum and are considered an exception requiring approval of project manager or building engineer.
- D. J-hooks or better must be installed without exception.

**2.2 UNACCEPTABLE INSTALLATIONS**

- A. Free flight of cables
- B. Resting or attaching of cables on pipes, conduits, HVAC duct work, fire sprinkler systems, basket tray, basket tray supports or on the ceiling tiles/grid.

**END OF SECTION**

---

**SECTION 270533****CONDUITS AND BACK BOXES FOR  
COMMUNICATIONS SYSTEMS****PART 1 - GENERAL****1.1 RELATED DOCUMENTS**

- A. Division 26 – Electrical work

**PART 2 - PRODUCTS****2.1 APPROVED PRODUCT**

- A. Conduits and Back boxes shall meet the construction requirements of the NEC for the type of structure and space in which they are installed and will be of the diameter and size to provide adequate fill, bend radius and connector space. Refer to section 270528.

**PART 3 - EXECUTION****3.1 CONDUIT SIZING**

- A. Conduit size shall be based on the type of cable installed and the required fill ratio and bend radius associated with the type of cable specified.
  - 1. Minimum conduit size to back box for CAT6A F/UTP shall be 1-inch EMT.
- B. Conduit and installation shall be provided by Division 26.
- C. All conduit stubs shall be installed with plastic bushings appropriate for the size of conduit used.
- D. Conduits that stub to accessible ceiling shall be installed in the direction to provide the shortest path to the TDR, complete with pull string.

**3.2 BACK BOX SIZING**

- A. New work back boxes for CAT6A F/UTP shall be a minimum of trade size 4-11/16" x 4-11/16" x 3" (depth) plus a 5/8" plaster ring to allow for proper bend radius and connector termination/installation. Side knockouts shall be avoided.
- B. Back boxes for rework shall meet the same specification as for new work.
  - 1. If existing back boxes or back boxes that are smaller due to construction restrictions, then devices such as extension rings, bezels or faceplates shall be used to modify the back box to insure proper bend radius and connector termination/installation.
    - a. Verification and approval of the size change must have DCO Infrastructure Cabling and engineering approval.

**3.3 BACK BOX COMPOSITION**

- A. All back boxes for IT systems shall be UL/CSA listed and approved for the purpose.

1. Non-metal back boxes shall not be used for any interior IT related device.

3.4 SPECIAL CONDITIONS – LEAD LINED WALLS FOR RADIATION CONTROL

- A. Refer to the complete IT Lead Lined Wall Procedure – Attachment Appendix 8

END OF SECTION



## SECTION 270536

CABLE TRAY FOR  
COMMUNICATIONS SYSTEMS

## PART 1 - GENERAL

## 1.1 RELATED DOCUMENTS

- A. This section shall be coordinated with Sections 270528, 270539, and 270543\_46

## 1.2 COORDINATION

- A. Prior to beginning installation, a kick-off meeting to properly coordinate the tray installation and expectations should be held. It should be arranged by the General Contractor, and at a minimum include representatives of the following trades: FP&D, Electrical (Div 26), Structured cable, Nurse Call, paging, building automation and control, plumbing, HVAC, fire sprinkler, framing, and others as applicable. The Data Center Operations Infrastructure Cabling Team will lead the meeting.
- B. The wire basket tray routing shall be approved by the low voltage CI cable contractor (Div. 27 sub-contractor), and the Data Center Operations.
- C. Where adequate space is available a Triple tier J-Hook pathway shall parallel the basket trays for other services
1. The triple tier J-Hooks shall be installed by the cable tray installer.
- D. Single J-Hooks as needed to extend beyond the triple tier, shall be installed by the trade that will be utilizing them.
- E. Cable tray shall be a high priority installation to allow adequate time for proper and complete cable installation prior to ceiling grid.

## PART 2 - PRODUCTS

## 2.1 APPROVED PRODUCT

- A. The Cable Tray shall meet or exceed the below characteristics of construction and features:
1. It shall be fully welded and available in a galvanized silver or powder coat black finish
  2. Have an optional construction using "elongated" shaped wires offering a more broad-based support for installed cables.
  3. Cable ladder shall be used in data rooms for horizontal management above the racks.
  4. Ladder shall match the manufacturer of the data racks or exact equal.
  5. Ladder shall be assembled with manufacturer approved parts and methods.
- B. APPROVED MANUFACTURES
1. WBT – Wire Basket Tray (preferred)
  2. Siemon RoutelT™ Wire Mesh Cable Tray, or equal basket type tray
  3. Cabofil per owner's approval

## 2.2 PART NUMBERS (SUBMITTAL REQUIRED)

- A. Cable Tray
1. Refer to plans for part numbers.

PART 3 - EXECUTION

3.1 PATHWAY INSTALLATION

A. Supports

1. Installed per Manufacturer's Specifications and utilize components specific to the maintenance of proper access in and out of the cable tray using bend delimiters.
2. Distance between supports shall not exceed 5 feet
  - a. Less distance between supports required if per manufacturer's instructions.
  - b. Minimum of one support required within 24" on each side of any junction point.
3. Supports shall be of the trapeze design to provide maximum stability.
  - a. Each support shall attach to structure via its own hangers.
    - 1) All hanger supports shall be constructed of a rigid material such as all-thread.
    - 2) All hangers and supports shall be installed perpendicular and plumb to the tray. No angle supports shall be permitted unless augmented perpendicularly.
    - 3) Vibration and sway (seismic) damping required.
    - 4) Provide support across width of tray underneath, not via basket side wires.
    - 5) Building walls do not qualify as a support and shall not be used as a support.
4. Supports shall be of sufficient strength to support at least 200% of the expected load
5. Wall mounted angle brackets shall not be used as a load bearing support for cable tray.

B. Complete system access

1. Cable tray shall have a dedicated free clearance zone surrounding it.
  - a. 12" clear space shall be provided on the side where natural feed will occur.
  - b. 6" clear space shall be provided on the side opposite the feed access.
  - c. 8" clear space above the top of tray minimum – recommended 12".
  - d. 3" clear space below the tray.
2. Exception: other services may pass through the free clearance zone provided it is perpendicular to the tray direction and providing they do not exceed 6' in width or interfere with the access to pull wire in the tray.

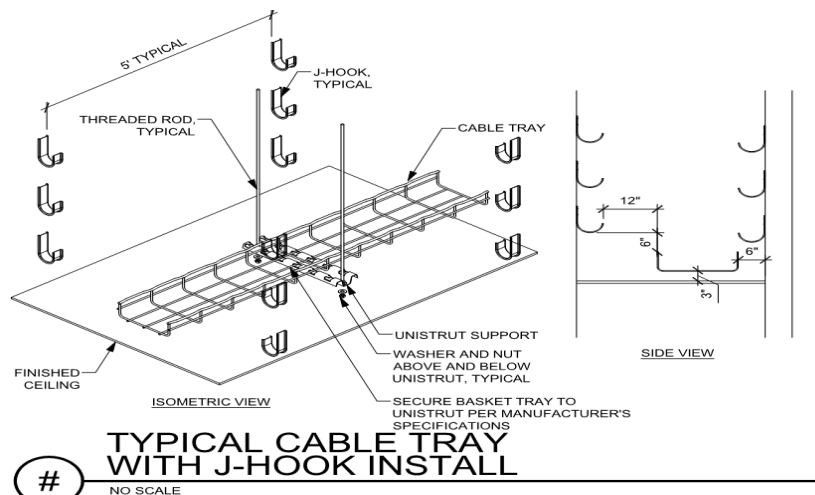

3.2 ROUTING OF BASKET TRAY

- A. Exact cable tray location shall be coordinated with other trades to ensure proper clearances and access. Prior to installation, final cable tray routing must be approved by the Owner's Data Center Operations/Infrastructure cabling team.
- B. Cable tray shall be installed in straight lines, either parallel or perpendicular to building lines
- C. Cable tray shall follow corridor paths
  - 1. Routing above rooms and other partitions shall be avoided
- D. Cable tray and flush penetrations shall be utilized over hard-lid areas as specified.
- E. Access panels shall be provided where needed to provide access to the cable tray on both sides of the wall in hard lid areas within 3' or less of the basket tray.

3.3 TRAY INTEGRITY

- A. Tray shall be installed as a complete, continuous system with no open spaces, cut outs, or missing segments. Bonding between sections shall be accomplished by the manufacturer's approved clamp or designated method.
- B. Tray shall be free from obstructions, other systems, trash or debris. Access to the tray shall be provided as outlined.
- C. There shall not to be any other trades infrastructure or equipment attached to or supported by the basket tray or basket tray support system.
- D. Tray must not be notched or cut-out to accommodate other trades. Repairs will not be accepted. Section replacement will be required at no cost to owner.
- E. As much tray material as possible shall be left uncut at turns, junctions, elevation changes, width changes, etc. Overlap shall be clamped to maximize strength and prevent pinch points.

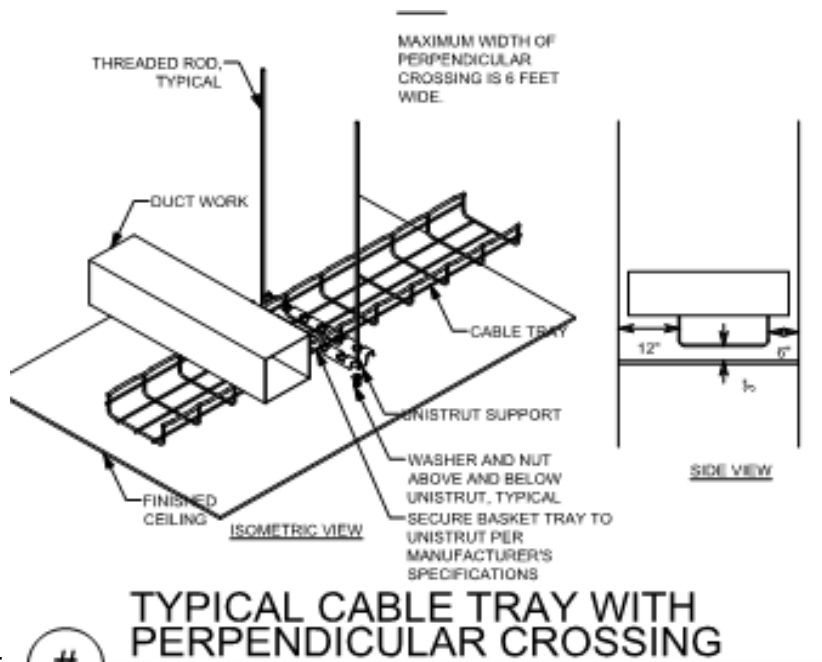

PART 4 - #

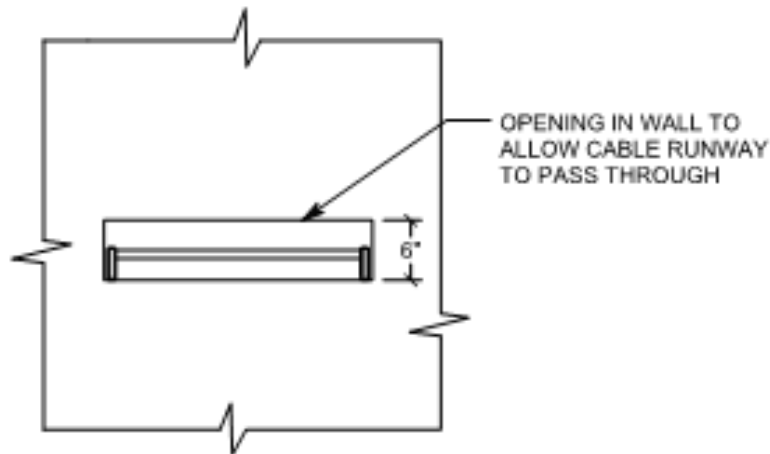

## PART 5 - # CABLE RUNWAY THROUGH WALL DETAIL

### 5.1 WALL OR OTHER PENETRATIONS (SUBMITTAL REQUIRED)

- A. Fire and smoke rated assemblies
  - 1. Penetrations shall comply with all fire and smoke prevention methods per codes and as outlined elsewhere in this document, including Section 270528 and Division 7.
- B. Approved penetration methods
  - 1. Preferred barrier penetration method shall be to run the tray continuous through the barrier, with closure provided by Firestop pillows.
    - a. Framing shall be boxed around openings to permit proper pillow insertion. Coordinate with framing contractor.
  - 2. Sleeves or conduits
    - a. EZ-Path or alternate penetrations must provide 150% of the designed cross-sectional area of the basket.
    - b. Conduit permitted only with written pre-bid permission or engineering notation on the drawings.
    - c. Each penetration sleeve or conduit shall be bonded on both sides of the penetrated barrier using UL and AHJ approved methods.
  - 3. All penetrations shall be positioned in-line with the cable tray to facilitate ease of pulling conductors and provide a straight-line path.
    - a. The bottom of the penetration device shall be flush with the bottom of the cable tray
    - b. Side-to-side penetrations must be completely within the cable tray space or directly above whenever possible.
  - 4. Approved penetration devices shall be a minimum size of 4"
    - a. Total penetration space at each location shall be sized for 20% growth and be equal to or greater than the cross-sectional area of the basket tray.
    - b. Approved devices where smaller penetrations are permitted shall be a minimum size of 1".

5. Approved devices shall be approved by the local facility manager:
  - a. Fire rated STI EZ-Path
  - b. Hilti self-sealing device
  - c. Tray with enclosed wall and properly sized and installed pillows
  - d. Conduit sleeves
    - 1) Conduit sleeves should only be used as a last resort upon approval from owner's Data Center Operations Infrastructure Cabling representative.

## 5.2 UTILIZATION

- A. Capacity
  1. Trays and penetration devices shall be properly sized
    - a. Provide a maximum calculated fill ratio of 40% to an inside depth not to exceed 3 inches (75 mm)
    - b. Provide capacity to allow for at least 20% future growth
- B. Systems served
  1. Cable trays, J-hooks, and penetrations shall be dedicated to a single system. Mixing of other systems with voice and data shall not be permitted in tray or J-hook paths.
  2. Exception: Different systems may share cable tray providing the following conditions are met:
    - a. Less than 40% overall fill is maintained, plus 20% additional space for growth
    - b. There is a minimum 3" separation between systems
    - c. There is a grounded physical divider between systems
- C. Restricted content in trays
  1. The wire basket tray shall only contain cables for the voice and data communications systems.
    - a. If there is sufficient space in the tray, and with approval from both the data network sub-contractor and the Data Center Operations, certain other IP services may share tray space. (i.e. camera, telemetry, similar).
    - b. Service loops must not reduce tray capacity.
    - c. Nurse call cabling shall be run in the J-Hook path. All nurse call installations must provide their own path or utilize the triple J-Hook system.
- D. Triple J-Hook path assignments
  1. The Lower tier of the triple J-Hook path is designated for Card Access and building automation and controls
  2. The Middle tier of the triple J-Hook path may alternately be utilized for Nurse Call, or other EMI producing systems.
  3. The Top tier of the triple J-Hook path is designated for satellite, DAS, or similar systems.
  4. When a triple J-hook pathway is not installed or available each system provider shall install their own j-hook pathway and wall penetrations.
  5. Service loop and slack shall not interfere with other pathways.

END OF SECTION

## SECTION 270543/46

UNDERGROUND DUCTS, UTILITY POLES,  
AND RACEWAYS FOR INTER-  
BUILDING/CAMPUS CABLE ROUTING

## PART 1 - PRODUCTS

## 1.1 INTER-BUILDING/CAMPUS CABLE ROUTING

- A. The backbone subsystem shall include cable installed between buildings via approved underground, tunnel, direct -buried, aerial or any combination of these from the Campus Distributor/Main Cross-connect (CD/MC/TEC) to Building Distributor/Intermediate Cross-connect (BD/IC/TDR) in a multi-building campus.
  - 1. 4" Conduit is required
  - 2. (3) 1 ¼" inner ducts shall be installed in all 4" conduits going building to building.
  - 3. Armored Fiber is required.
  - 4. Microduct/microfiber is optional.
- B. Backbone pathways shall be installed or selected such that the minimum bend radius and pulling tension of backbone cables is kept within cable manufacturer specifications both during and after installation.
- C. In an underground system, adequate underground conduit space shall be available and accessible at each building. The conduits shall not exceed a fill ratio of 40%.
  - 1. All underground systems shall be designed to prevent water runoff from entering the building. All underground systems must be cleared of any moisture prior to installation of any cable type. These systems must be sealed at both ends when not in use and after cable installation to prevent moisture and rodent infiltration.

## PART 2 - EXECUTION

## 2.1 INSTALLATION

- A. The backbone cables shall be installed in a hierarchical star topology, emanating from the Campus Distributor/Main Cross-connect to each satellite building, Building Distributor/Intermediate Cross-connect or Floor Distributor/Horizontal Cross-connect located in a telecommunication room. All Inter-building/Campus cables shall be installed to the applicable codes and regulations.
- B. Where redundant paths are required, they shall be separated by a minimum of 24".
  - 1. Separate innerducts are required for each leg of the redundant path.
  - 2. Separate physical routing for each path shall be utilized where possible.
- C. Optical fiber shall be run for all Inter-building/Campus backbone segments, and as a recommendation, at least one balanced twisted-pair cable should be run for each Inter-building backbone segment.
  - 1. Fibers will be Fusion Spliced in the telecommunications rooms using LC Pigtails in wall mounted interconnect centers or rack mounted panels equipped with sufficient ports, slack storage space and splice trays if required to terminate and secure all fibers.
- D. ST connectors are no longer recommended in the TIA 568-C.3 standard but may be used in legacy installations.
- E. Over-voltage Circuit Protection shall be utilized for cabling which enters or exits a building shall comply with applicable codes and regulations.
- F. OSP (outside plant) cables shall transition to an ISP (inside plant) within 50 feet of changing environment, per national and local codes and regulations.

END OF SECTION

## SECTION 270553

IDENTIFICATION FOR LOW-VOLTAGE  
CABLES AND LABELING

## PART 1 - GENERAL

## 1.1 NOT USED

## PART 2 - PRODUCTS

## 2.1 LABELING

- A. Structured cabling shall be labeled in accordance with ANSI/TIA 606-B standards.
- B. A unique identifier shall be marked on each faceplate to identify it as connecting hardware.
- C. Each port in the faceplate shall be labeled with its identifier.
- D. A unique identifier shall be marked on each piece of connecting hardware to identify it as connecting hardware.
- E. Each port on the connecting hardware shall be labeled with its identifier.
- F. Cable Labeling
  - 1. Label System
    - a. Labels Identification (Labeling) System:
      - 1) Brady
      - 2) Dymo
      - 3) Hellerman-Tyton
      - 4) Panduit
      - 5) Acceptable alternate
        - a) Approval from Data Center Operations Infrastructure Cabling team member required prior to bid
  - 2. Cable Labels
    - a. Self-adhesive vinyl or vinyl-cloth wraparound tape markers, machine printed with alphanumeric cable designations. Plastic, self-adhesive labels are not acceptable.
    - b. Each end of the Horizontal cables shall be labeled with a mechanically generated label within 300mm (12 in) of the end of the cable jacket with the link identifier which shall be a unique configuration determined by owner. This also applies to the Backbone Cables.
  - 3. Flat-surface labels
    - a. Self-adhesive vinyl or vinyl-cloth labels, machine printed with alphanumeric cable designations
  - 4. Contractor shall:
    - a. Provide transparent plastic label holders, and 4 pair marked colored labels.
    - b. Install colored labels according to the type of field as per ANSI/TIA 606-B.1 color code designations.
- G. PALLETTE
  - 1. Use the owners color-code guidelines for voice, data, cross-connect, riser, and backbone fields. Otherwise, use the ANSI/TIA 606-B designation strip color-code guidelines for voice, data, cross-connect, riser, and backbone fields. Color designations for F/UTP cable:
    - a. Intermountain Healthcare Standard Wiring Palettes for Horizontal Cabling



b.	Use	Color
	1) Data & IP Phones	Blue
	2) Analog Phone	Blue
	3) Security Card Readers	Grey/Yellow
	4) IP Security Cameras	Blue
	5) Fire Systems	Red
	6) TV Coax	Black
	7) Public Address/Telecom Patching in TEC only	White
	8) Clinical Engineering –	Orange
	a) Monitoring, Bed Systems	Orange
	b) Nurse Call (5e)	Orange
	c) Real time patient data	Orange
	9) Wireless	Yellow
	10) Foreseer (Belden 1422)	Red
H.	Outlet/Jack/Faceplate Icons/labeling will match the color of the cable attached to the back side of the outlet/jack.	

### PART 3 - EXECUTION

#### 3.1 GENERAL IDENTIFICATION

- A. Installer shall label all cable, regardless of length.
- B. Identify system components, wiring, and cabling complying with TIA/EIA-606-B.1. Comply with requirements for identification specified in Division 26 Section "Identification for Electrical Systems."
- C. Color-code cross-connect fields. Apply colors to voice and data service backboards, connections, covers, and labels.
- D. Using cable management system software specified in Part 2, develop Cabling Administration Drawings for system identification, testing, and management. Use unique, alphanumeric designation for each cable and label cable, jacks, connectors, and terminals to which it connects with same designation. At completion, cable and asset management software shall reflect as-built conditions.
- E. Cable Schedule: Post in prominent location in each equipment room and wiring closet. List incoming and outgoing cables and their designations, origins, and destinations. Protect with rigid frame and clear plastic cover. Furnish an electronic copy of final comprehensive schedules for Project.
- F. Cabling Administration Drawings: Show building floor plans with cabling administration-point labeling. Identify labeling convention and show labels for telecommunications rooms, backbone pathways and cables, entrance pathways and cables, terminal hardware and positions, horizontal cables, work areas and workstation terminal positions, grounding buses and pathways, and equipment grounding conductors. Follow convention of TIA/EIA-606-B.1. Furnish electronic record of all drawings, in software and format selected by Owner

#### 3.2 CONCEALED ENDS

- A. Jacks, connectors, terminations, and similar that are in concealed locations such as above grid ceilings, shall have additional labeling. The additional label shall be on the face of the grid in a visible location, immediately adjacent to the termination location.

#### 3.3 CABLE AND WIRE IDENTIFICATION

- A. Label each cable visibly within 4 inches of each termination and tap, where it is accessible in a cabinet or junction or outlet box, and elsewhere as indicated.

- B. Each wire connected to building-mounted devices is not required to be numbered at device if color of wire is consistent with associated wire connected and numbered within panel or cabinet.
- C. Label each terminal strip and screw terminal in each cabinet, rack, or panel.
  - 1. Individually number wiring conductors connected to terminal strips and identify each cable or wiring group being extended from a panel or cabinet to a building mounted device shall be identified with name and number of particular devices as shown.
  - 2. Label each unit and field within distribution racks and frames.
- D. Labels shall be preprinted or computer-printed type with printing area and font color that contrasts with cable jacket color but still complies with requirements in TIA/EIA-606-B.1.

END OF SECTION

---

**SECTION 271100****EQUIPMENT ROOM FITTINGS****PART 1 - GENERAL****1.1 RELATED DOCUMENTS**

- A. Requirements of the following Division 26 sections apply to this section
  - 1. Basic electrical requirements
  - 2. Basic electrical materials and methods
  - 3. Grounding, earthing, and bonding
- B. Standards
  - 1. Minimum equipment room specifications shall comply with the 2010 AIA Guidelines for Design and Construction of Healthcare Facilities.
  - 2. Minimum recommended room sizes are requirements, not suggestions.
  - 3. Enterprise IS Architecture (EISA) maintains several documents around standards. The primary standards list is the EISA Standards 2010 – Master List. Occasionally, there is a need to breakout specific standards for an area.

**1.2 SUMMARY**

- A. This Section specifically details the facilities design and operations standards to be utilized for Intermountain Health Care's Data Rooms (TEC) and data closets (TDR).

**1.3 COMMON REQUIREMENTS**

- A. Rack layout and mounting
  - 1. Standard room layouts are located on the plans.
- B. Rack and wall mounting locations
  - 1. Rack and wall space use is pre-designated at the design stage. Before mounting any equipment on a wall or in a rack, the location must be verified by the Div 27 sub-contractor and the Data Center Operations.

**1.4 DEFINITIONS**

- A. **Data Center** – Major computer/technology/network facilities providing a significant percentage of the data and application services for the enterprise.
- B. **Data Rooms – ((TEC) Technology Equipment Center)** – Purpose built buildings or rooms that provide communications point-of-presence along with some data and applications services for a local facility or region.
- C. **TSER (Telecommunications Service Entrance Room)** – Houses the point at which data and voice circuits and services enter the facility and outdoor cabling interfaces with the building infrastructure. Typically, the TSER will be located in the TEC.
- D. **Data Closets – ((TDR) Technology Distribution Room)** – Specific location within a facility that provides communication services for a specific area (floor, wing, office area) of that facility only. A secure, flexible, and easily managed location for the structured cabling systems, network electronics, clinical systems, nurse call systems, and other technology and communications equipment.

**PART 2 - TECHNOLOGY ROOM SPECIFIC REQUIREMENTS****2.1 TECHNOLOGY EQUIPMENT CENTER (TEC)**

- A. Each Hospital will have a dedicated TEC which will serve as the main communications point-of-presence along with data and application services for the local facility or region. Houses the core networking equipment, application servers and data storage devices that serve the buildings on the campus. The Telecommunications Service Entrance Room (TSER) will be in the same room.

## 2.2 TEC IN HOSPITALS

- A. Physical Construction
  1. The TEC should be in an area easily accessed for delivery of equipment and high traffic without disturbing patient care.
  2. The size of the TEC will be based on the number of cabinets required to support the campus, plus 30% growth.
  3. Walls will be constructed from the floor to the deck and be completely sealed from surrounding spaces.
  4. A minimum 50% of open wall space will have ¾" fire rated plywood covering the walls.
  5. Fire rated plywood shall be painted with fire resistant paint, leaving the fire rating stamp un-painted.
  6. The TEC should not have a ceiling other than the deck.
  7. Static Dissipative Tile is required in the TEC.
  8. The door to the TEC shall be 8' tall and 4' wide to accommodate the cabinet height.
  9. The walls of the TEC should not have any windows installed.
- B. Layout
  1. Cabinets will be in a cold isle configuration.
  2. Containment will be installed, including removable ceiling panels and isle doors.
- C. Electrical
  1. The electrical distribution system will follow an A (BLUE) – B (RED) design.
  2. Each system A (BLUE) and B (RED) will be backed up by a dedicated UPS.
  3. Outlet type is L21-30
  4. All power is to be run in conduit.
  5. Lighting will be installed above each isle.
- D. Mechanical
  1. The mechanical system will be a precision cooling solution installed in an in row, N+1 configuration designed to maintain 72 degrees F at mid cabinet.
  2. The mechanical system will be redundant and concurrently maintainable including on the electrical supply.
  3. The system shall meet engineering specifications for the room at 110 degrees outside air at 4500 feet above sea level.
  4. Chilled water, DX (Air Cooled) and Glycol (30% polyethylene glycol to water) are all acceptable cooling strategies.
- E. Security
  1. Doors will be fitted with an auditable card reader.
- F. Fire System
  1. A pre-action dry pipe fire system will be installed
- G. Monitoring
  1. Eaton Forseeer system will be used to monitor all critical systems.
  2. Forseeer cables will be run to all UPSs, cooling units and TDRs.
  3. One Cat 6a F/UTP cable to each UPS.

## 2.3 TEC in Clinics and Office Buildings

- A. Clinics and Offices will have a room which will serve as a TEC and TDR. This room will be sized to accommodate the multifunction of the space.

## 2.4 TEC/TDR in Clinics

- A. Physical Construction
  1. TDRs should be in a central location off the main corridor away from patient areas.
  2. TDRs should be stacked from floor to floor.
  3. TDR size will be at least 12' x 14'.
  4. Walls will be constructed from the floor to the deck and be completely sealed from surrounding spaces.
  5. A minimum 50% of open wall space will have ¾" fire rated plywood covering the walls.
  6. Fire rated plywood shall be painted with fire resistant paint, leaving the fire rating stamp un-painted.
  7. The TDR should not have a ceiling other than the deck.
  8. Flooring can be Static Dissipative Tile or Epoxy Paint.
  9. 3' wide door is required.
  10. When permissible, doors shall swing out of the room to provide maximum available space and rapid egress.
- B. Layout
  1. Racks in a single row with the front being the cold isle.
  2. The front of the racks should face the door.
- C. Electrical
  1. The electrical distribution system will follow an A (BLUE)-B (RED) design.
  2. System A(BLUE) will be backed up by a dedicated UPS.
  3. System B(RED) will be from a dedicated utility circuit.
  4. Outlet type is L6-30 and L5-20.
  5. All power is to be run in conduit.
  6. Lighting will be installed above each isle.
- D. Mechanical
  1. TDRs will have redundant cooling
    - a. Primary cooling is from the facility cooling system via a dedicated source.
    - b. Secondary cooling is from a standalone split or ceiling mount source.
    - c. The secondary system will be fed from the facility generator equipment electrical source if available.
    - d. The Mechanical system will be designed to maintain 72 degrees F at mid rack.
    - e. The coordination scheme between primary and secondary cooling systems can be accomplished by setting the primary system to 72 degrees F and the secondary system to 75 degrees F.
- E. Security
  1. Doors will be fitted with an auditable card reader.
- F. Fire System
  1. TDRs will utilize the facility fire detection and suppression systems.
  2. Sprinkler heads should have a 200-degree fuse.
  3. Sprinklers should be protected from accidental activation.
- G. Monitoring
  1. TDRs will be monitored using Eaton/Foreseer.
  2. Run 3 foreseer cables to each TDR.
  3. One Cat6a F/UTP cable to each UPS.

## 2.5 TEC/TDR in Offices

- A. Physical Construction
  1. TDRs should be in a central location off a main corridor.
  2. TDRs should be stacked from floor to floor.
  3. TDR size will be at least 12' x 14'.

4. Walls will be constructed from the floor to the deck and be completely sealed from surrounding spaces.
  5. A minimum 50% of open wall space will have ¾" fire rated plywood covering the walls.
  6. Fire rated plywood shall be painted with fire resistant paint, leaving the fire rating stamp un-painted.
  7. The TDR should not have a ceiling other than the deck.
  8. Flooring can be Static Dissipative Tile or Epoxy Paint.
  9. 3' wide door is required.
  10. When permissible, doors shall swing out of the room to provide maximum available space and rapid egress.
- B. Layout
1. Racks in a single row with the front being the cold isle.
  2. The front of the racks should face the door.
- C. Electrical
1. The electrical distribution system will follow an A (BLUE)-B (RED) design.
  2. System A(BLUE) will be backed up by a dedicated UPS.
  3. System B(RED) will be from a dedicated utility circuit.
  4. Outlet type is L6-30 and L5-20.
  5. All power is to be run in conduit.
  6. Lighting will be installed above each row.
- D. Mechanical
1. TDRs will have redundant cooling system designed to maintain 72 degrees F at mid rack.
    - a. Primary cooling is from the facility cooling system via a dedicated source.
    - b. Secondary cooling is from a standalone split or ceiling mount source.
      - 1) The secondary system will be fed from the facility generator equipment electrical source if available.
    - c. The coordination scheme between primary and secondary cooling systems can be accomplished by setting the primary system to 72 degrees F and the secondary system to 75 degrees F.
  2. Doors will be fitted with an auditable card reader.
- E. Fire System
1. TDRs will utilize the facility fire detection and suppression systems.
  2. Sprinkler heads should have a 200-degree fuse.
  3. Sprinklers should be protected from accidental activation.
- F. Monitoring
1. TDRs will be monitored using Eaton/Foreseer.
  2. Run 3 foreseeer cables to each TDR.
  3. One Cat 6a F/UTP cable to each UPS.

## 2.6 TECHNOLOGY DISTRIBUTION ROOM (TDR)

- A. There shall be a minimum of one TDR on each floor of the facility. TDR's shall be provided throughout the facility as necessary to meet the 292' (90-meter) maximum cables distance. The TDR is located on each floor within a facility to house equipment and cabling, providing communication and technology services for a specific area of that facility. Based on the different needs of different facilities, the TDR's will be broken down into three categories. Hospital, Clinic and Office spaces.

## 2.7 TDR IN HOSPITALS

- A. Physical Construction
1. TDRs should be in a central location off a main corridor and away from patient areas.
  2. TDRs should be stacked from floor to floor.

3. TDR size will be at least 14' x 16'.
  4. Walls will be constructed from the floor to the deck and be completely sealed from surrounding spaces.
  5. A minimum 50% of open wall space will have ¾" fire rated plywood covering the walls.
  6. Fire rated plywood shall be painted with fire resistant paint, leaving the fire rating stamp un-painted.
  7. The TDR should not have a ceiling other than the deck.
  8. Flooring can be Static Dissipative Tile or Epoxy Paint.
  9. 3' wide door is required.
  10. When permissible, doors shall swing out of the room to provide maximum available space and rapid egress.
- B. Layout
1. Racks will be in a cold isle configuration.
  2. Two rows with the cold isle in the middle.
- C. Electrical
1. The electrical distribution system will follow an A (BLUE)-B (RED) design.
  2. Each system A(BLUE) and B(RED) will be backed up by a dedicated UPS.
  3. Outlet type is L6-30 and L5-20.
  4. All power is to be run in conduit.
  5. Lighting will be installed above each row.
- D. Mechanical
1. TDRs will have redundant cooling designed to maintain 72 degrees F at mid rack.
    - a. Primary cooling is from the facility cooling system via a dedicated source.
    - b. Secondary cooling is from a standalone split or ceiling mount source.
    - c. The secondary system will be fed from the facility generator equipment electrical source if available.
    - d. The coordination scheme between primary and secondary cooling systems can be accomplished by setting the primary system to 72 degrees F and the secondary system to 75 degrees F.
- E. Security
1. Doors will be fitted with an auditable card reader.
- F. Fire System
1. TDRs will utilize the facility fire detection and suppression systems.
  2. Sprinkler heads should have a 200-degree fuse.
  3. Sprinklers should be protected from accidental activation.
- G. Monitoring
1. TDRs will be monitored using Eaton/Foreseer.
  2. Run 3 foreseer cables to each TDR.
  3. One Cat 6a F/UTP cable to each UPS.

## 2.8 TDR in Clinics

- A. Physical Construction
1. TDRs should be in a central location off a main corridor and away from patient areas.
  2. TDRs should be stacked from floor to floor.
  3. TDR size will be at least 10' x 12'.
  4. Walls will be constructed from the floor to the deck and be completely sealed from surrounding spaces.
  5. A minimum 50% of open wall space will have ¾" fire rated plywood covering the walls.
  6. Fire rated plywood shall be painted with fire resistant paint, leaving the fire rating stamp un-painted.
  7. The TDR should not have a ceiling other than the deck.

8. Flooring can be Static Dissipative Tile or Epoxy Paint.
  9. 3' wide door is required.
  10. When permissible, doors shall swing out of the room to provide maximum available space and rapid egress.
- B. Layout
1. Racks in a single row with the front being the cold isle.
  2. The front of the racks should face the door.
- C. Electrical
1. The electrical distribution system will follow an A (BLUE)-B (RED) design.
  2. System A(BLUE) will be backed up by a dedicated UPS.
  3. System B(RED) will be from a dedicated utility circuit.
  4. Outlet type is L6-30 and L5-20.
  5. All power is to be run in conduit.
  6. Lighting will be installed above each isle.
- D. Mechanical
1. TDRs will have redundant cooling designed to maintain 72 degrees F at mid rack
    - a. Primary cooling is from the facility cooling system via a dedicated source.
    - b. Secondary cooling is from a standalone split or ceiling mount source.
    - c. The secondary system will be fed from the facility generator equipment electrical source if available.
    - d. The coordination scheme between primary and secondary cooling systems can be accomplished by setting the primary system to 72 degrees F and the secondary system to 75 degrees F.
- E. Security
1. Doors will be fitted with an auditable card reader.
- F. Fire System
1. TDRs will utilize the facility fire detection and suppression systems.
  2. Sprinkler heads should have a 200-degree fuse.
  3. Sprinklers should be protected from accidental activation.
- G. Monitoring
1. TDRs will be monitored using Eaton/Foreseer.
  2. Run 3 foreseeer cables to each TDR.
  3. One Cat 6a F/UTP cable to each UPS.

## 2.9 TDR in Offices

- A. Physical Construction
1. TDRs should be in a central location off a main corridor.
  2. TDRs should be stacked from floor to floor.
  3. TDR size will be at least 10' x 12'.
  4. Walls will be constructed from the floor to the deck and be completely sealed from surrounding spaces.
  5. A minimum 50% of open wall space will have ¾" fire rated plywood covering the walls.
  6. Fire rated plywood shall be painted with fire resistant paint, leaving the fire rating stamp un-painted.
  7. The TDR should not have a ceiling other than the deck.
  8. Flooring can be Static Dissipative Tile or Epoxy Paint.
  9. 3' wide door is required.
  10. When permissible, doors shall swing out of the room to provide maximum available space and rapid egress.
- B. Layout
1. Racks in a single row with the front being the cold isle.
  2. The front of the racks should face the door.
- C. Electrical
1. The electrical distribution system will follow an A (BLUE)-B (RED) design.



2. System A(BLUE) will be backed up by a dedicated UPS.
  3. System B(RED) will be from a dedicated utility circuit.
  4. Outlet type is L6-30 and L5-20.
  5. All power is to be run in conduit.
  6. Lighting will be installed above each isle.
- D. Mechanical
1. TDRs will have redundant cooling designed to maintain 72 degrees F at mid rack.
    - a. Primary cooling is from the facility cooling system via a dedicated source.
    - b. Secondary cooling is from a standalone split or ceiling mount source.
    - c. The secondary system will be fed from the facility generator equipment electrical source if available.
    - d. The coordination scheme between primary and secondary cooling systems can be accomplished by setting the primary system to 72 degrees F and the secondary system to 75 degrees F.
- E. Security
1. Doors will be fitted with an auditable card reader.
- F. Fire System
1. TDRs will utilize the facility fire detection and suppression systems.
  2. Sprinkler heads should have a 200-degree fuse.
  3. Sprinklers should be protected from accidental activation.
- G. Monitoring
1. TDRs will be monitored using Eaton/Foreseer.
  2. Run 3 foreseer cables to each TDR.
  3. One Cat 6a F/UTP cable to each UPS.

### PART 3 - EXECUTION

#### 3.1 COMMON REQUIRED CHARACTERISTICS FOR TDR, TEC, & TSER

- A. SECURITY - COMMON
1. Any visitor, vendor, or contractor requiring access to a Technology Room, who does not have appropriate approvals or clearances, must be escorted by a properly credentialed tech from the appropriate system.
  2. The main technology equipment shall be secured in a dedicated, locked Technology Room.
  3. Unused access jacks should be disconnected from the patch panels, and unused switch ports disabled.
  4. Technology Rooms shall be dedicated to the data and telecommunications functions.
  5. Access to the Technology Room shall be restricted to authorized service personnel and shall not be shared with building services that may interfere with the main networking interfaces, the networking equipment, the application servers, data storage devices, and telecommunications equipment systems.
  6. Technology Rooms shall not be used for building maintenance services, custodial services, or be used for general storage.
  7. Security cameras may be installed in each Technology Room upon owner's preference.
    - a. At entrances
    - b. At the end of each row of equipment racks
    - c. In electrical and mechanical rooms serving the Technology Room
    - d. Approved camera manufacturers: Axis and Bosch
  8. Access to a Technology Room shall be restricted and controlled by an auditable access control system. The access control system shall comply with the requirements of this document.
  9. All secure data areas must be secured by an auditable badge reader system.

- a. Refer to plans or quotes for detailed information
- b. Approved supplier: Intermountain Lock and Security Supply /  
3106 S Main St / Salt Lake City, UT 84115 / 801-486-0079
- c. Owner of security locks and badge readers:  
Intermountain Healthcare Data Center
- d. For programing on the Medeco XT Electronic Keys contact:  
Intermountain Healthcare Data Center

#### B. PHYSICAL ENVIRONMENT

1. The Technology Room shall be in a dry area not subject to flooding and should be as close as possible to the electrical service room in order to reduce the length of the bonding conductor to electrical grounding system.
2. The Technology Room shall be in an accessible, non-sterile area.
3. Access to the Technology Room shall be directly off a corridor and not through another space.
4. The Technology Room shall be located to avoid large ducts, beams, and other building elements that may interfere with proper cable routing and may limit future access.
5. Mechanical and electrical equipment or fixtures not directly and exclusively related to the support of the Technology Room shall not be installed in, pass through, or enter the Technology Room.
6. Technology rooms shall not be located on exterior walls.
7. Technology rooms shall not have windows or other exterior openings.

### 3.2 TECHNOLOGY DISTRIBUTION ROOM (TDR) / DATA CLOSET

#### A. ELECTRICAL ENVIRONMENT

1. Separation from sources of EMI shall be in accordance with ANSI/TIA/EIA-569-C and local codes.
2. Communication grounding/earthing and bonding shall be in accordance with applicable codes and regulations. It is recommended that the requirements of IEC/TR3 61000-5-2 - Ed. 1.0, ANSI-J-STD-607-C, or both be observed throughout the entire cabling system.
  - a. All racks, equipment frames, furniture, flooring, ductwork within the IT space shall be bonded to the Central Ground bar provided and installed by Division 26.
    - 1) No AC electrical equipment bonding will be done at the Central Ground Bar. AC electrical grounding and bonding will be done according to the NEC.
3. Some TDRs will require redundant power and data feeds. See plans and drawings.
4. Lighting in the TDRs should be a minimum of 500 lx (50-foot candles) at the lowest point of termination.
  - a. Light switch should be easily accessible when entering the room.
  - b. Lighting will be fed from the generator system or have fixtures with battery backup.
5. A minimum of two dedicated duplex or two dedicated simplex electrical outlets, each on a separate 120V 20A circuit, should be provided for equipment power. Additional convenience duplex outlets should be placed at 1.8 m (6 ft) intervals around the perimeter walls.
  - a. Only twist lock receptacles will be used for rack power points. Type L-6-30R for 208 volt and type Nema L-5-20R for 120 volt
6. All power is to originate from the facilities generator backup system with one system (A-B) originating from the critical system.
7. All circuits serving the TDR and the equipment within it shall be dedicated to serving the TDR.

8. TDRs shall be connected by a backbone of insulated, #6 (minimum) to 3/0 AWG stranded copper cable between all technology rooms. This cable shall be provided and installed by Division 26.
- B. MECHANICAL ENVIRONMENT
  1. Reliable cooling shall be provided.
    - a. Based on criticality tiering structure individual rooms may require redundant, concurrently maintainable cooling systems.
    - b. Tier structure level shall be determined from the design guide.
  2. Heat load shall be calculated at 4KW per equipment rack
  3. Temperature and humidity in the TDR shall be controlled to an operating range of 64 to 75 degrees F (18 to 24 degrees C) with 30 to 55 percent relative humidity.
- C. EQUIPMENT
  1. Each TDR shall be connected to the TEC (Technology Equipment Center) to provide a building-wide network and communications system.
  2. All racks, cabinets, sections of cable tray, and metal components of the technology system that do not carry electrical current shall be grounded.

### 3.3 TECHNOLOGY EQUIPMENT CENTER (TEC) / DATA ROOM

- A. ELECTRICAL ENVIRONMENT
  1. The TDR and TEC electrical environments shall match with the following exceptions:
  2. All circuits serving the TEC and the equipment within it shall be dedicated to serving the TEC.
- B. MECHANICAL ENVIRONMENT
  1. TEC and TSER have the same mechanical environment.
  2. Reliable cooling shall be provided.
  3. Heat load shall be calculated at 4KW per equipment rack
  4. Temperature and humidity in the TEC shall be controlled to an operating range of 64 to 75 degrees F (18 to 24 degrees C) with 30 to 55 percent relative humidity.
- C. EQUIPMENT
  1. Each TEC shall be connected to the TSER (Telecommunications Service Entrance Room) to provide an enterprise-wide network and communications system.
  2. All racks, cabinets, sections of cable tray, and metal components of the technology system that do not carry electrical current shall be grounded.

### 3.4 TELECOMMUNICATION SERVICE ENTRANCE ROOM (TSER) / D-MARC

- A. PURPOSE
  1. The TSER (Telecommunications Service Entrance Room) equipment subsystem shall consist of shared (common) electronic communications equipment in the TEC or the TSER required to interface this equipment and distribution hardware to the transmission media of enterprise Wide Area Network (WAN) infrastructure.
  2. The TSER shall be equipped to contain telecommunications equipment, cable terminations, and associated cross-connects.
    - a. Note that the AIA/State guidelines specify that the minimum size for a TSER is 12' by 14'.
    - b. Doors shall swing out of the room to provide maximum available space and rapid egress.
      - 1) Exception: where prohibited by fire or safety code.
  3. The TSER shall be dedicated to the telecommunications function.
- B. MECHANICAL ENVIRONMENT
  1. Reliable cooling and heating shall be provided.
  2. Temperature and humidity in the TSER shall be controlled to an operating range of 64 to 75 degrees F (18 to 24 degrees C) with 30 to 55 percent relative

- humidity.
- C. EQUIPMENT
1. The TSER (Telecommunications Service Entrance Room) shall be connected to the specified WAN equipment to provide connectivity to the enterprise-wide network and communications system.
  2. All racks, cabinets, sections of cable tray, and metal components of the technology system that do not carry electrical current shall be grounded.

END OF SECTION

## SECTION 271116

CABINETS, RACKS, FRAMES,  
AND ENCLOSURES

## PART 1 - GENERAL

## 1.1 RELATED DOCUMENTS

- A. Cabinets and racks specifications are in TIA569-C and in the ET pages of the plans.

## PART 2 - PRODUCTS

## 2.1 APPROVED PRODUCT

## A. OPEN RACKS

- 1. For rack-mounted installations in a telecommunications room the installer shall use a 19 inch by 3-inch-deep equipment rack.
  - a. Equipment Rack 19" X 8', 52 RU, Black – Chatsworth 55053-715
  - b. Equipment Rack 19" X 7', 45 RU, Black – Chatsworth 55053-703
  - c. Exception: Where other size cabinets are specified by design team at owner's direction

## B. WIRE MANAGERS

- 1. Part Numbers
  - a. Vertical Wire Manager, Double Sided, Black 10" wide x 8' tall – Chatsworth 40096-715
  - b. Vertical Wire Manager, Double Sided, Black 10" wide x 7' tall – Chatsworth 40096-703
  - c. Horizontal Wire Manager, 4U – Panduit PEHF4
- 2. Typical Standard Layout
  - a. Layout is 10" vertical manager, then 19" rack, then 10" vertical manager, then 19" rack, then 10" vertical manager.
  - b. Where more than 2 racks are called for, maintain the pattern of 10" vertical wire management on the ends, and 10" vertical management between racks.

## C. CABINETS

- 1. Standard Cabinet
  - a. 2-Sided Cabinet – Vertiv E4562121120001S
  - b. 1-Sided Cabinet – Vertiv E4562122120001S
- 2. Wall Mount Cabinet
  - a. Vertical Wall Mount Cabinet – Legrand VWMSD-4RU-42-B
  - b. Vertical Wall Mount Cabinet – Legrand VWMSD-8RU-42-B
  - c. Fixed Mounting Rail Kit – Legrand VWM-RR-4RU
  - d. Fixed Mounting Rail Kit – Legrand VWM-RR-8RU
  - e. Pivoting Mounting Rail Kit – Legrand VWM-PIV-4RU
  - f. Fan Kits with 115 VAC fans – Legrand VWMFK-115
  - g. Top Brush Grommet Kit – Legrand VWMBGK
  - h. Circular Knockout Grommet Kit – Legrand VWMGR-30

END OF SECTION

## SECTION 271119

TERMINATION BLOCKS AND  
PATCH PANELS

## PART 1 - GENERAL

## 1.1 RELATED DOCUMENTS

- A. Requirements of the following Division 26 sections apply to this section
  - 1. Basic electrical requirements
  - 2. Basic electrical materials and methods
  - 3. Grounding, Earthing, and Bonding

## PART 2 - PRODUCTS

## 2.1 APPROVED PRODUCT

- A. PATCH PANELS – COPPER
  - 1. 48 Port CAT 6A Shielded, 1RU Angled Patch Panel with Outlets – Siemon Z6AS-PA-48A
  - 2. 48 Port CAT 6A Shielded, 1RU Flat Patch Panel with Outlets – Siemon Z6AS-PNL-U48K
  - 3. 24 Port CAT 6A Shielded, 1RU Flat Patch Panel with Outlets – Siemon Z6AS-PNL-U24K
  - 4. 48 Port CAT 5e, 2RU Angled Patch Panel, 110 Style – Siemon HD5-48A
  - 5. 48 Port CAT 5e, 2RU Flat Patch Panel, 110 Style – Siemon HD5-48
  - 6. 24 Port CAT 5e, 1RU Angled Patch Panel, 110 Style – Siemon HD5-24A
  - 7. 24 Port CAT 5e, 1RU Flat Patch Panel, 110 Style – Siemon HD5-24
  - 8. 19" Angled Blank Filler Panel, 1U, Black – Siemon PNL-BLNKA-1
    - a. Provide blank fillers where appropriate.
  - 9. 19" Flat Blank Filler Panel, 1U, Black – Siemon PNL-BLNK-1
    - a. Provide blank fillers where appropriate.
- B. PATCH PANELS – FIBER
  - 1. Rack Mount Fiber Enclosure – Siemon RIC3-48E-01
  - 2. Wall Mount Fiber Enclosure – Siemon SWIC3G-AA-01
  - 3. Blank Adapter Plate, Black – Siemon RIC-F-BLANK-01
  - 4. 12F-LCUPC-SM-Loaded-Splice Cassette - Siemon – RSC12-LCUSMA-B1
- C. CABINET PATCH PANEL – FIBER
  - 1. Lightstack Surface Mount Module Enclosure – Siemon – LSE-01
  - 2. Lightstack Surface Mount Splice Enclosure – Siemon – LSS-01
  - 3. LightStack LC Adapter Plate – Siemon LS-LS12-01C-AQ

## PART 3 - EXECUTION

## 3.1 INSTALLATION

- A. For angled patch panels, the terminations shall cross in the back to the opposite path of the patch panel to maximize available cable bend radius.
- B. See illustration below in this section:

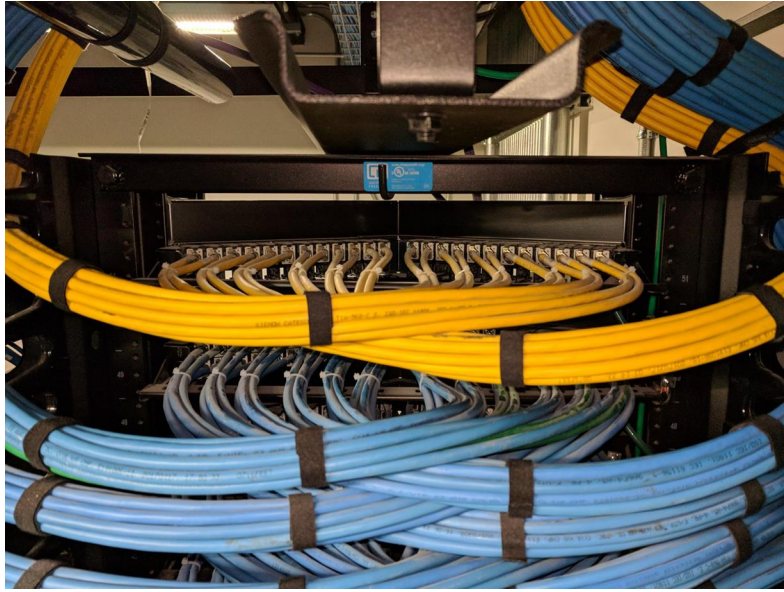

END OF SECTION

## SECTION 271300

## BACKBONE CABLING

## PART 1 - GENERAL

## 1.1 RELATED DOCUMENTS

- A. Drawing and general provisions of the Contract, including General and Supplementary Conditions and Division 01 Specification Sections, apply to this section.
- B. Section 27 05 28 – Pathways for Communications Systems.

## 1.2 DEFINITIONS

- A. INTRA-BUILDING CABLING
  - 1. Cable that runs between telecommunications rooms (TRs) inside a building. Can be vertical or horizontal in physical orientation. It consists of the backbone transmission media between these locations and the associated connecting hardware terminating this media.
- B. INTER-BUILDING / CAMPUS CABLING
  - 1. Cable that runs between buildings in a campus environment. It is normally a first-level backbone cable beginning at the main cross-connect in the equipment room of the hub building and extending to the intermediate cross-connect in the equipment room of a satellite building. Campus Backbones require optical fiber cable to be installed to support high speed data applications.
  - 2. Customer owned outside plant (OSP) cabling.

## PART 2 - PRODUCTS

## 2.1 PERMITTED BACKBONE MEDIA

- A. Cables allowed for use in the backbone include:
  - 1. CAT 6A F/UTP Riser, Blue, Data – Siemon 9A6R4-A5-06-R1A
  - 2. CAT 6A F/UTP Plenum, Blue, Data – Siemon 9A6P4-A5-06-R1A
  - 3. 50 Pair Category 3 Riser Cable Gray – General Cable 2133161 or equal
  - 4. Fiber Optic Cable, Single-mode, 24 Strand, Armored Indoor/Outdoor Cable, Black – Siemon 9BG8P024L-E201A
  - 5. Fiber Optic Cable, Single-mode, 24 Strand, Armored, Riser Cable, Yellow – Siemon 9BC8P024L-205A
  - 6. Fiber Optic cable, Multi-mode, OM4, 12 Strand, Armored, Riser Cable, Aqua – Siemon 9BC5P012G-T512A (Data Centers must be OM4 or better)
- B. The cable shall support voice, data and imaging applications. The bending radius and pulling strength requirements of all backbone cables shall be observed during handling and installation.
- C. Multi-pair twisted pair cable is intended to support analog voice applications and shall be tested for continuity only.
- D. In addition to meeting the applicable performance specifications, all copper and optical fiber cable shall be appropriate for the environment in which it is installed.

## 2.2 MEDIA PRODUCTS

- A. COPPER



1. The total channel length between the Campus Distributor/Main Cross-connect and to any floor Distributor/Horizontal Cross-connect shall not exceed the following length limits for copper cabling:
  - a. 2,000 m (6,560 ft) for balanced twisted pair for PBX/Class A (100 kHz) applications.
  - b. 200 m (656 ft) for balanced twisted pair for Class B ( $\leq 1$  MHz) applications.
  - c. 100 m (328 ft) for balanced twisted-pair categories 6, 6A & 7 (per Backbone segment when providing a two-level Backbone).
- B. MULTIMODE OPTICAL FIBER
  1. See Siemon website for supportable fiber distances
    - a. Laser qualified 50/125 $\mu$ m multimode fiber optical fiber cables shall be in compliance with the following standards ISO/IEC 11801:2002 OM3, ANSI/TIA-568-C.3, ANSI/TIA-568-C.1 and Telcordia GR-409-CORE as well as the guaranteed application distances, attenuation, bandwidth, and group index of refraction requirements.
    - b. Specifications:
      - 1) Shall support 10GBASE-SX for all horizontal workstations, risers and short length backbone (<300 m) locations.
      - 2) Constructed for overfilled launch (OFL) and restricted mode launch (RML) bandwidth to ensure compatibility with both LED and laser light sources.
      - 3) Have an Aqua Outer Jacket and be available in cable ratings including OFNR and OFNP.
- C. SINGLE MODE OPTICAL FIBER
  1. See Siemon website for supportable fiber distances
  2. Single-mode optical fiber cable shall be used for 1st and 2nd Level Backbone applications only.
  3. All fiber is to fusion spliced terminations.

### PART 3 - EXECUTION

#### 3.1 TOPOLOGY

- A. The Backbone cabling shall use a conventional hierarchal star topology.
  1. There shall be no more than two (2) levels of cross-connects between the campus distributor/main cross –connect (CD/MC) and any given floor distributor/horizontal cross-connect (FD/HC).
  2. From the FD/HC no more than one cross-connect shall be passed through to reach the CD/MC.
- B. Splicing of UTP, F/UTP and S/FTP copper cables is not permitted.

#### 3.2 TYPICAL TDR BACKBONE

- A. A typical TDR backbone for a hospital campus shall consist of:
  1. Redundant (2 ea.) 24 strand single-mode fiber each routed in a separate path.
  2. One 50 pair copper feed line.

END OF SECTION

---

**SECTION 271500****HORIZONTAL CABLING****PART 1 - GENERAL****1.1 RELATED DOCUMENTS**

- A. Drawings and general provisions of the Contract, including General and Supplementary Conditions and Division 01 Specification Sections, apply to this section.
- B. Section 27 05 28 - Pathways for Communications Systems

**1.2 SUMMARY**

- A. This section includes requirements and guidelines for the installation of F/UTP, ScTP, and Fiber horizontal cabling.
  - 1. Horizontal cable and its connecting hardware provide the means of transporting signal between the telecommunications outlet/connector and the horizontal cross-connect located in the communications termination room. This cabling and its connecting hardware are called "permanent link," a term that is used in the testing protocols.

**PART 2 - EXECUTION****2.1 HORIZONTAL CABLE**

- A. Quantity
  - 1. Two horizontal cables shall be routed to each work area. Cable connected to information outlets shall be CAT6A F/UTP, 4-pair, 100Ω balanced twisted-pair.
    - a. A work area is approximately 100 sq. ft. and includes the components that extend from the telecommunications outlet/connectors to the station equipment.
    - b. Two (2) standard cables shall be run to each wireless access point location per current best practice.
    - c. One (1) standard horizontal cable may be run to the following locations:
      - 1) Each building control system enclosure as directed by the building controls vendor.
      - 2) Each IP Video Surveillance Camera at each of the designated locations.
      - 3) Each wall phone.
      - 4) Each wall monitor/display.
  - 2. For voice or data applications, 4-pair balanced twisted-pair or fiber optic cables shall be run using a star topology from the telecommunications room serving that floor to every individual information outlet. The customer prior to installation of the cabling shall approve all cable routes.
  - 3. Installation interfaces shall be T568B wiring standards.
- B. Maximum Length
  - 1. All horizontal cables, regardless of media type, shall not exceed 90 m (295 ft.) from the telecommunications outlets in the work area to the Floor Distributor/Horizontal Cross connect (FD/HC) located in the Telecommunication Room.
  - 2. Distributor/Horizontal Cross connect (FD/HC) located in the Telecommunication Room.
  - 3. The combined length of jumpers, patch cords inclusive of equipment cables in

4. the Floor Distributor/Horizontal Cross-connect shall not exceed 5m (16 ft.).  
The maximum length of Work Area equipment cables shall be 5m (16 ft.) If a MuTOA (Multiple User Telecommunication Outlet) environment exists, then the maximum equipment cable shall not exceed 22m (72 ft.) (Lake Park Facility)
  5. Terminate all conductors; no cable shall contain un-terminated elements. Make terminations only at indicated outlets, terminals, cross-connects, and patch panels.
- C. Minimum Length
1. It is recommended that a minimum horizontal cable distance of 15m (49 ft.) shall be maintained between the telecommunications room and the work area. This will provide adequate Insertion Loss/Attenuation for applications over 1 Gig.
  2. For installations with consolidation points, a minimum horizontal cable distance of 15m (49 ft.) shall be maintained between the telecommunications room and consolidation point, and 5m (16 ft.) between the consolidation point and the work area. This will provide adequate Insertion Loss/Attenuation for applications over 1 Gig.
- D. Splice Free
1. Each run of balanced twisted-pair cable between Floor Distributor/Horizontal Cross-connect in the telecommunication room and the information outlet at the Work Area shall not contain splices.
  2. Bridged taps and splices shall not be installed in the horizontal cabling
- E. Protection
1. Horizontal distribution cables shall not be run in under slab raceways that are damp or wet locations unless suitably rated for the environment.
    - a. Under slab conduits that are outside of the building are considered wet locations.
- F. Slack -Service Loop – Routing
1. In the work area, a minimum of 1m (3 ft) should be left for balanced twisted-pair cables and fiber cables.
  2. In telecommunications rooms a minimum of 3m (10 ft) of slack should be left for all cable types. This slack must be neatly managed on trays or other support types

## 2.2 SEPARATION

- A. Separation from EMI sources
1. Installation shall comply with BICSI TDMM and TIA/EIA-569-B for separating unshielded copper voice and data communication cable from potential EMI sources, including electrical power lines and equipment.
  2. Separation between open communications cables or cables in nonmetallic raceways and unshielded power conductors and EMI Source shall be as follows:
    - a. EMI Source Rating Less Than 2 kVA: A minimum clearance of 5 inches.
    - b. EMI Source Rating between 2 and 5 kVA: A minimum clearance of 12 inches.
    - c. EMI Source Rating More Than 5 kVA: A minimum clearance of 24 inches.
  3. Separation between communications cables in grounded metallic raceways and unshielded power lines or EMI Source shall be as follows:
    - a. EMI Source Rating Less Than 2 kVA: A minimum clearance of 2-1/2 inches.
    - b. EMI Source Rating between 2 and 5 kVA: A minimum clearance of 6 inches.
    - c. EMI Source Rating More Than 5 kVA: A minimum clearance of 12 inches.
  4. Separation between communications cables in grounded metallic raceways and

power lines and EMI Source located in grounded metallic conduits or enclosures shall be as follows:

- a. EMI Source Rating Less Than 2 kVA: A minimum clearance of 2 inches.
  - b. EMI Source Rating between 2 and 5 kVA: A minimum clearance of 3 inches.
  - c. EMI Source Rating More Than 5 kVA: A minimum clearance of 6 inches.
5. Separation between Communications Cables and Electrical Motors and Transformers, 5 kVA or 1 HP and Larger: A minimum clearance of 48 inches.
  6. Separation between Communications Cables and Fluorescent Fixtures: A minimum clearance of 5 inches
- B. Other Clearances
1. Horizontal pathways used for telecommunications cabling shall be dedicated for telecommunications use and not shared by other building services.
  2. In a false ceiling environment, a minimum of 75 mm (3 in) shall be observed between the cable supports and the false ceiling.

## 2.3 PATHWAY

- A. Cable Tie Wraps
1. Cable Tie Wraps are not permitted as a pathway device or support.
  2. Tie Wraps shall only be used to provide strain relief at termination points.
  3. Tie wraps shall not be over tightened to the point of deforming or crimping the cable sheath.
- B. Constraints
1. Horizontal cables shall be installed in "dry" locations that provide protection from moisture levels above the intended operating range of inside plant (ISP) cables.
    - a. If cabling is intentionally or unintentionally exposed to water or otherwise coated with or exposed to direct contact with solvents, paints, adhesives, sealants or other third-party materials, Siemon will not warranty the cabling product or if after the warranty has been issued, it would become void. Therefore, any cabling that has been exposed as listed above, must be removed and replaced.
  2. Horizontal pathways shall be installed or selected such that the minimum bend radius of horizontal cables is kept within manufacturer specifications both during and after installation.
  3. A minimum of a 1" diameter conduit is recommended for new construction. Existing conduits will require the reduction of the number of cables placed in the conduit to meet the required fill ratio.
    - a. The Contractor shall observe the bending radius and pulling strength requirements of the 4-pair balanced twisted-pair and fiber optic cable during handling and installation.
      - 1) 4-Pair UTP, F/UTP, S/FTP bend radius = 4 times outside diameter of cable under no-load conditions. 8 times the outside diameter under load (pulling 110 N/25 lbf.) conditions.
      - 2) Multi-pair or Hybrid cable bend radius = 10 times the outside diameter under all conditions.
      - 3) 2-Fiber and 4 Fiber cables bend radius = 25mm (1 in.) under no-load conditions. 50mm (2 in.) under load (pulling 222 N 50 lbf)
  4. Cable shall not be run through structural members or in contact with pipes, ducts, or other potentially damaging items.
  5. Cable that passes through non-Intermountain Healthcare spaces must be installed in conduit.
  6. Horizontal cabling shall contain no more than one transition point or consolidation point between the horizontal cross-connect and the telecommunications outlet/connector.

7. Do not install bruised, kinked, scored, deformed, abraded cable or otherwise damaged cable. Do not splice cable between termination, tap, or junction points. Remove and discard cable if damaged during installation and replace it with new cable.
  8. During Cold-Weather Installation, bring cable to room temperature before de-reeling. Heat lamps shall not be used for heating.
- C. Capacity
1. The number of horizontal cables placed in a cable support or pathway shall be limited to the number of cables that will not alter the geometric shape of the cables.
  2. Maximum pathway (cable tray/basket tray/wireway) capacity shall not exceed a calculated fill ratio of 50% to a maximum of 75 mm (3 in) inside depth.
  3. Maximum conduit pathway capacity shall not exceed a 40% fill. However, perimeter and furniture fill are limited to 60% fill for move and changes. A 40% fill ratio is the maximum fill for CAT6A F/UTP cables.
  4. All unused cables shall be removed
    - a. Or labeled at both ends designating future purpose and locations of each end.

END OF SECTION

SECTION 271513

COPPER CABLE

PART 1 - GENERAL

1.1 RELATED DOCUMENTS

- A. Drawings and general provisions of the Contract, including General and Supplementary Conditions and Division 01 Specification Sections, apply to this Section.

1.2 PALLETTE

- A. Color palette shall be in accordance with Section 27 05 53

1.3 SUMMARY

- A. This Section covers approved F/UTP cable types
- B. Systems shall be CAT6A F/UTP unless a written deviation has been approved.
- C. CAT6A UTP and CAT6A F/UTP shall not be mixed on the same campus.
- D. This cable shall be used for both voice and data applications and shall be plenum rated where required by code

PART 2 - PRODUCT

2.1 APPROVED PRODUCT

- A. TYPE 6A F/UTP (foil over unshielded twisted pair) - Siemon
  - 1. CAT 6A F/UTP Riser, (CMR) – Siemon 9A6R4-A5-(XX)-R1A
  - 2. CAT 6A F/UTP Plenum, (CMP) – Siemon 9A6P4-A5-(XX)-R1A
    - a. (XX) = Color – 06, Blue – 05, Yellow – 09, Orange

END OF SECTION

## SECTION 271543

## FACEPLATES AND CONNECTORS

## PART 1 - GENERAL

## 1.1 RELATED DOCUMENTS

- A. Drawings and general provisions of the Contract, including General and Supplementary Conditions and Division 01 Specification Sections, apply to this Section.

## 1.2 DEFINITION

- A. Work-Area Cabling
  - 1. The work area is comprised of work area outlet/connectors, faceplates, outlet boxes and equipment cords. It acts as the interface to the horizontal cabling from the horizontal cross-connect (HC) to telephone, network equipment, wireless access points (WAP) and OIP devices.

## PART 2 - PRODUCT

## 2.1 OUTLETS

- A. Category 6A Jack – Siemon Z6A-S(XX)
  - 1. Use (XX) to specify color.
  - 2. Universal design allows the same outlet to be mounted in a flat or angled orientation.
- B. Category 6A Z-Plug WO Latch Protector – Siemon ZP1-6AS-(00)S
- C. Voice Outlet, Single Gang Faceplate, White W/Wall Hung Phone W/6A Insert – Siemon MX-WP-Z6AS-SS

## 2.2 FACEPLATES/BOXES

- A. 10G Single Gang Faceplate, White, 4 Position – Siemon 10GMX-FP-04-02
- B. MAX Single Gang Faceplate, White – Siemon MX-FP-S-(XX)-02
  - 1. USE (XX) to specify the number of ports.
- C. MAX Single Gang Faceplate, Stainless Steel, 4 Position, with Label Holder – Siemon MX-FP-S-04-SS-L
  - 1. To be used in the Operation Rooms
- D. Surface Mount Box, White, 2 Position – Siemon MX-SMZ2-02
- E. Furniture Faceplate, Black – Siemon MX-UMA-01
- F. Conference Room Table Inserts should include and HDMI port.

## PART 3 - EXECUTION

## 3.1 WORK AREA TERMINATION

- A. All balanced twisted-pair cables wired to the telecommunications outlet/connector, shall have 4-pairs terminated in eight-position modular outlets in the work area. All pairs shall be terminated.
- B. Outlet/connector back boxes shall be a minimum 4-11/16 square box (4-11/16" x 4-11/16" x 3") with a minimum single gang 5/8" mud ring for new construction to accommodate the CAT6A connectors.

- C. Existing back boxes will require a faceplate stand-off and/or a faceplate that can accommodate a bezel to extend the CAT6A jack out to allow the installation of the CAT6A connectors.
- D. All outlets need to be installed in the angled position.

END OF SECTION



## SECTION 271619

## PATCH CABLES

## PART 1 - GENERAL

## 1.1 SUMMARY

- A. This section is issued as a guide for patch cable installations in the Data Center, wiring closets (TDR) and user areas where patch cables are required for connectivity to IP and TDM phones, and IP data connectivity needs for Intermountain Healthcare. All patch cables will support voice, data, and imaging applications within the Intermountain Healthcare Enterprise.

## PART 2 - PRODUCTS

## 2.1 APPROVED PRODUCT

- A. Patch Cable, CAT 6A Shielded - Siemon SP6A-S (XX)-(XX)  
1. Use 1<sup>st</sup> (xx) to specify length. Use 2<sup>nd</sup> (xx) for color.
- B. Patch Cable, CAT 5e, Orange – Siemon MC5-(XX)-0909  
1. Use (xx) to specify length. For use with NURSE CALL only.
- C. Patch Cable, CAT 5e, White – Siemon MC5-(XX)-0202  
1. Use (xx) to specify length.  
2. For use in the TEC for the Copper Backbone Patch only.
- D. Patch Cable, Fiber, Singlemode Duplex W/LC Connectors, Yellow – Siemon FJ2-LCULCUL-(xx)  
1. Use (xx) to specify length.
- E. Patch Cable, Fiber, Multimode Duplex W/LC Connectors, Aqua – Siemon FJ2-LCLC5V-(xx)AQ  
1. Use (xx) to specify length. For use in the Data Center.

## PART 3 - EXECUTION

## 3.1 PALLETTE

- A. Patch Cable Color Codes  
1. The Intermountain Healthcare Enterprise standard for patch cable color is in Section 27 05 53.  
2. The patch cable color shall match the feed cable color to identify the service provided.
- B. Contractor furnished  
1. All patch cables for the TEC, TDR's shall be included in the low voltage contract and will be required to match or exceed the existing level of the installed structured cabling system.  
2. All patch cables for the user areas shall be Owner furnished and will be required to match or exceed the existing level of the installed structured cabling system.  
3. All patch cables shall be Owner installed.  
4. The quantity of patch cables to be provided by the low voltage contractor shall be specified in the plans.  
a. 50% 5ft – 30% 7ft – 15% 10ft – 5% 15ft

END OF SECTION

**SECTION 27 41 33**  
**MASTER ANTENNA TELEVISION SYSTEM**

**PART 1 - GENERAL**

**1.1 RELATED DOCUMENTS**

- A. Drawings and general provisions of the Contract, including General and Supplementary Conditions and Division 01 Specification Sections, apply to this Section.

**1.2 SUMMARY**

- A. This Section includes the following:
1. Master antenna television systems using direct broadcast satellite service or community cable as the signal source. Provide broadband coaxial cabling for distributing television signal to user interface outlets.

**1.3 DEFINITIONS**

- A. Broadband: For the purposes of this Section, wide bandwidth equipment or systems that can carry signals occupying in the frequency range of 54 to 1002 MHz. A broadband communication system can simultaneously accommodate television, voice, data, and many other services.
- B. Carrier: A pure-frequency signal that is modulated to carry information. In the process of modulation, it is spread out over a wider band. The carrier frequency is the center frequency on any television channel.
- C. CATV: Community antenna television; a communication system that simultaneously distributes several different channels of broadcast programs and other information to customers via a coaxial cable.
- D. dBmV: Decibels relative to 1 mV across 75 ohms. Zero dBmV is defined as 1 mV across 75 ohms.  $\text{dBmV} = 20 \log_{10}(V_1/V_2)$  where  $V_1$  is the measurement of voltage at a point having identical impedance to  $V_2$  (0.001 V across 75 ohms).
- E. Headend: The control center of the master antenna television system, where incoming signals are amplified, converted, processed, and combined into a common cable along with any locally originated television signals, for transmission to user-interface points. It is also called the "Central Retransmission Facility."
- F. RF: Radio frequency.
- G. TV Outlet: End point of Contractor's responsibility for Work of this Section. TV outlets are the 75-ohm terminals on device plates.

**1.4 SYSTEM DESCRIPTION**

- A. System shall consist of direct broadcast satellite service from the existing headend through a new coaxial cable distribution system.
- B. Headend processing equipment shall be owner provided.
- C. Distribution of community television service signals. This will include coordinating with Owner's selected service provider for processing the signals as needed to provide specified services combined into a single-feed point ready for connection into the distribution system. Obtain signal levels, and noise and distortion characteristics from service provider as the point of departure for system layout and final equipment selection.
- D. Cable distribution system consisting of coaxial cables, user interfaces, directional signal taps and splitters, RF amplifiers, signal equalizers, power supplies, and required hardware complying with IEEE 802.7 and resulting in performance parameters specified in this Section. System shall be capable of distributing television channels as follows, according to EIA 542:
  - 1. 12 VHF Channels and FM: 2 through 6 low-band VHF, FM band; and 7 through 13 high-band VHF.
  - 2. 60 CATV Channels 2 through YY (61) low, mid, high, super, and ultra band.
- E. Hardware Requirements: Use modular, plug-in, solid-state electronic components. Install amplifiers and other powered equipment on plywood backboards installed in the designated TDR locations.

**1.5 PERFORMANCE REQUIREMENTS**

- A. Minimum acceptable distribution system performance at all user-interface points shall be as follows:
  - 1. RF Video Carrier Level: Between 2 and 10 dBmV.
  - 2. Relative Video Carrier Level: Within 3 dB to adjacent channel.
  - 3. Channel Frequency Response: Across any 6-MHz channel in 54- to 220-MHz frequency range, referenced to video, signal amplitude shall be plus or minus 1 dB, maximum.
  - 4. Carrier-to-Noise Ratio: 45 dB or more.
  - 5. RF Visual Signal-to-Noise Ratio: 43 dB or more.
  - 6. Cross Modulation: Less than minus 50 dB.
  - 7. Terminal Isolation from Television to Television: 25 dB, minimum.
  - 8. Hum Modulation: 2 percent, maximum.

**1.6 SUBMITTALS**

- A. Product Data: For each type of product indicated.
- B. Shop Drawings: Show fabrication and installation details for television equipment.
  - 1. Include plans, elevations, sections, details, and attachments to other work.
  - 2. For coaxial cable, include the following installation data for each type used:
    - a. Nominal OD.
    - b. Minimum bending radius.
    - c. Maximum pulling tension.

3. Functional Block Diagram: Show single-line interconnections between components for headend and distribution system to user-interface points. Show cable types and sizes.
  4. Dimensioned plan and elevations of headend equipment. Show access and workspace requirements.
  5. Wiring Diagrams: Power, signal, and control wiring; and grounding.
  6. Design Calculations: Calculate signal attenuation budget and show calculated line and equipment losses for the system based on the functional block diagram, to show that proposed system layout can be expected to perform up to specification. Allowable losses between components and User Interface shall be used to determine size and type of coaxial cable.
- C. Equipment List: Include every piece of equipment by model number, manufacturer, serial number, location, and date of original installation. Add testing record of each piece of adjustable equipment, listing name of person testing, date of test, and description of as-left set points.
- D. Source quality-control test reports on coaxial cable sweep tests.
- E. Field quality-control test reports.
- F. Operation and Maintenance Data: For headend and distribution system to include in emergency, operation, and maintenance manuals. In addition to items specified in Division 01 Section "Operation and Maintenance Data," include the following:
1. Lists of spare parts and replacement components recommended to be stored at the site for ready access.
  2. Include dimensioned plan and elevation views of components and enclosures. Show access and workspace requirements.
- G. Samples: Full size, for each outlet and finish plate, for colors and textures required.

## **1.7 QUALITY ASSURANCE**

- A. Electrical Components, Devices, and Accessories: Listed and labeled as defined in NFPA 70, Article 100, by a testing agency acceptable to authorities having jurisdiction, and marked for intended use.
- B. Comply with NECA 1.
- C. Comply with NFPA 70.

## **1.8 PROJECT CONDITIONS**

- A. Environmental Limitations: System components shall be equipped and rated for the environments where installed.

## **1.9 COORDINATION**

- A. Coordinate size and location of raceway system, and provisions for electrical power to equipment of this Section.
- B. Coordinate Work of this Section with requirements of Owner's selected service provider.

**1.10 EXTRA MATERIALS**

- A. Furnish extra materials described below, before installation begins, that match products installed and that are packaged with protective covering for storage and identified with labels describing contents. Provide no fewer than one of each item listed below. Deliver extra materials to Owner.
1. Fuses: One for every 10; each type and rating.
  2. Splitters: One for every 10 installed.
  3. MATV Distribution Power Amplifiers: One for every 10; each type installed.
  4. MATV Signal Traps: One for every 10; each type used.
  5. MATV Attenuators: One for every 10; each type used.
  6. Cable: 100 feet; each type used.

**PART 2 - PRODUCTS****2.1 MANUFACTURERS**

- A. In other Part 2 articles where titles below introduce lists, the following requirements apply to product selection:
1. Manufacturers: Subject to compliance with requirements, provide products by one of the manufacturers specified.

**2.2 SYSTEMS REQUIREMENTS**

- A. Components: Modular plug-in, heavy-duty, industrial- or commercial-grade units.
- B. Equipment: Silicon-based, solid-state, integrated circuit devices.
- C. Power Supply Characteristics: Devices shall be within specified parameters for ac supply voltages within the range of 105 to 130 V.
- D. Protect signal cables and connected components against transient-voltage surges by suppressors and absorbers designed specifically for the purpose. Comply with Division 26 Section "Transient-Voltage Suppression for Low-Voltage Electrical Power Circuits."
- E. Provide ac-powered equipment with integral surge suppressors, complying with UL 1449.
- F. RF and Video Impedance Matching: Signal-handling components, including connecting cable, shall have end-to-end impedance-matched signal paths. Match and balance devices used at connections where it is impossible to avoid impedance mismatch or mismatch of balanced circuits to unbalanced circuits.

**2.3 MATV EQUIPMENT**

- A. Description: Signal-source components and amplifying equipment, distribution components, and interconnecting wiring. System shall receive signals from sources, amplify and process them, and distribute them to outlets for receiving sets.

- B. MATV System Quantitative Performance Requirements: Level and quality of signal at each outlet from each designated channel and source shall comply with Specifications below when tested according to 47 CFR 76.

## 2.4 MATV DISTRIBUTION COMPONENTS

- A. Manufacturers:
  - 1. Blonder Tongue Laboratories, Inc.
  - 2. Channel Master, Inc.
  - 3. Motorola Broadband Communications Sector.
  - 4. Pico Macom
- B. Distribution Equipment: Broadband amplifier and combining networks for receiving television signals and outputting the signals to cable distribution system.
- C. Broadband Amplifier:
  - 1. Frequency Range: 54 to 750 MHz.
  - 2. Frequency Response: Plus or minus 1.0 dB across passband.
  - 3. Maximum Noise: 10 dB.
  - 4. Minimum Return Loss: 16 dB.
  - 5. I/O Impedance: 75 ohms.

## 2.5 DISTRIBUTION COMPONENTS

- A. Manufacturers:
  - 1. Blonder Tongue
  - 2. Channel Master
  - 3. Motorola Broadband Communications Sector.
  - 4. Pico Macom
- B. Distribution components shall be for signal processing and distribution downstream from headend equipment.
- C. Signal Splitters and Isolation Taps: Metal-enclosed directional couplers with brass connector parts.
  - 1. Return Loss: 17 dB.
  - 2. RFI Shielding: 100 dB.
  - 3. Isolation: 25 dB.
  - 4. Impedance: 75 ohms for input and output terminals.
  - 5. Electrically powered components shall be UL labeled.
- D. Signal Traps: Packaged filters tuned to interference frequencies encountered in Project.
- E. Attenuators: Passive, of fixed value, used to balance signal levels.
- F. Terminating Resistors: Enclosed units rated 0.5 W and matched for coaxial impedance.
- G. User-Interface Device (TV Outlets): Flush, female-type outlets for mounting in standard outlet box, with metallic parts of anodized brass, beryllium copper, or phosphor bronze.

1. Cable Connector: Female, Type F.
2. Wall Plates: Match materials and finish of power outlets in same space.
3. Attenuation: Less than 0.1 dB.
4. Voltage Standing-Wave Ratio: Less than 1.15 to 1.

## 2.6 CABLES

- A. Manufacturers:
1. Alpha Wire Company.
  2. Belden Inc.; Electronics Division.
  3. Coleman Cable.
  4. CommScope Properties, LLC.
  5. West Penn Wire/CDT; a division of Cable Design Technologies, Inc.
- B. Cable Characteristics: Broadband type, recommended by cable manufacturer specifically for broadband MATV applications. Coaxial cable and accessories shall have 75-ohm nominal impedance with a return loss of 20 dB minimum from 7 to 806 MHz, and shall be listed to comply with NFPA 70, Articles 810 and 820.
- C. RG-6/U, Plenum-Rated Indoor Distribution Cable (Horizontal Drop): No. 16 AWG, solid bare copper conductor; gas-injected foam-PE insulation. Double shielded with 100 percent aluminum-foil shield, 60 percent aluminum braid. Copolymer jacket. NFPA 70, Type CATV and UL 910.
- D. RG-11/U, Plenum-Rated Indoor Distribution Cable (Trunk): No. 14 AWG, solid bare copper conductor, gas-injected foam-PE insulation. Double shielded with 100 percent aluminum foil shield, 60 percent aluminum braid. Copolymer jacket. NFPA 70, Type CATV and UL 910.

## 2.7 CABLE CONNECTORS

- A. Manufacturers:
1. Amphenol Corporation.
  2. B&L Coaxial Connections, Ltd.
  3. Connect-Tech Products.
  4. Leviton Voice & Data Division.
- B. MATV Coaxial Cable Connectors: Type F, 75 ohms.

## 2.8 SOURCE QUALITY CONTROL

- A. Cable products shall be sweep tested at the factory before shipping at frequencies from 5 MHz to 1 GHz. Sweep test shall test the frequency response, or attenuation over frequency, of a cable by generating a voltage whose frequency is varied through the specified frequency range and graphing the results.

**PART 3 - EXECUTION****3.1 EXAMINATION**

- A. Examine pathway elements intended for coaxial cable installation. Check raceways, cables, trays, and other elements for compliance with accessibility for installation and maintenance, and other conditions affecting installation.
- B. Examine roughing-in for antenna to verify actual locations of cable connections before antenna installation.
- C. Examine walls, floors, roofs, equipment bases, and roof supports for suitable conditions where television equipment is to be installed.
- D. Proceed with installation only after unsatisfactory conditions have been corrected.

**3.2 INSTALLATION**

- A. Wiring Method: Install cables in raceways except in accessible indoor ceiling spaces, attics and as otherwise indicated. Conceal raceways and wiring except in unfinished spaces.
- B. Wiring within Enclosures: Bundle, lace, and train conductors to terminal points with no excess and without exceeding manufacturer's limitations on bending radii. Provide and use lacing bars and distribution spools.
- C. Splices, Taps, and Terminations: For power and control wiring, use numbered terminal strips in junction, pull, and outlet boxes; terminal cabinets; and equipment enclosures.
- D. Grounding: According to recommendations in IEEE 142 and IEEE 1100.

**3.3 COAXIAL CABLE INSTALLATION**

- A. Cold-Weather Installation: Bring cable to room temperature before dereeling. Heat lamps may not be used for heating.
- B. Cable may not be installed in same raceway with power cable.
- C. Coaxial cable shall not be spliced except on plywood backboards in wire closets, or in cabinets designated for the purpose.
- D. Outdoor connections shall be installed in enclosures meeting NEMA 250, Type 4X. Connectors shall be corrosion resistant with properly designed O-rings to keep out moisture.
- E. Do not use water-based cable pulling lubricants with PVC-jacketed cable.
- F. Do not exceed manufacturer's recommended minimum bending radiuses
- G. Pulling Cable: Do not exceed manufacturer's recommended pulling tensions. Do not install bruised, kinked, scored, deformed, or abraded cable. Do not splice cable between termination, tap, or junction points. Remove and discard cable if damaged during installation and replace it with new cable.



- H. Exposed Cable: Install parallel to building lines, follow surface contours, and support cable according to manufacturer's written instructions. Do not run adjacent and parallel to power or data cables.
- I. Cable Support: Install supports at intervals recommended in writing by cable manufacturer. Install supports within 6 inches of connector so no weight of cable is carried by connector. Use no staples or wire ties, pull tie-wrap snug, and do not over tighten.
- J. Signal Equalization: Where system performance may be degraded in certain operating modes, revise component connections and install distribution amplifiers and attenuators as required, providing a balanced signal across the system.
- K. Install passive circuit devices, such as splitters and attenuators, in wire closets or cabinets. Do not install attenuators as part of user-interface device outlets.

### **3.4 EQUIPMENT INSTALLATION**

- A. Mount distributed equipment as recommended by manufacturer. Group related items in methodical sequence.
- B. Arrange equipment to facilitate access for maintenance and to preserve headroom and passage space. Parts that require periodic service or maintenance shall be readily accessible. Headend components that require tuning adjustments shall be accessible from the front of equipment cabinets.
- C. Antenna Cable Entrance (If required): Use entrance fittings, seal, and waterproof penetrations of the building envelope.

### **3.5 IDENTIFICATION**

- A. Identify system components, wiring, cabling, and terminals according to Division 26 Section "Identification for Electrical Systems."

### **3.6 FIELD QUALITY CONTROL**

- A. Manufacturer's Field Service: Engage a factory-authorized service representative to inspect, test, and adjust field-assembled components and equipment installation, including connections. Report results in writing.
- B. Inspection: Verify that units and controls are properly installed, connected, and labeled, and that interconnecting wires and terminals are identified.
- C. Pretesting: Align and adjust system and pretest components, wiring, and functions to verify that they comply with specified requirements. Replace malfunctioning or damaged items. Retest until satisfactory performance and conditions are achieved. Prepare television equipment for acceptance and operational testing as follows:
  - 1. Use an agile receiver and signal strength meter or spectrum analyzer for testing.
  - 2. CATV Sources: Connect receiver to an agile demodulator or CATV set-top converter at CATV service entrance to the facility.

- D. Test Schedule: Schedule tests after pretesting has successfully been completed and system has been in normal functional operation for at least 14 days. Provide a minimum of 10 days' notice of test schedule.
- E. Operational Tests: Perform operational system tests to verify that system complies with Specifications. Include all modes of system operation. Test equipment for proper operation in all functional modes.
- F. Distribution System Acceptance Tests:
  - 1. Field-Strength Instrument: Rated for minus 40-dBmV measuring sensitivity and a frequency range of 54 to 812 MHz, minimum. Provide documentation of recent calibration against recognized standards.
  - 2. Signal Level and Picture Quality: Use a field-strength meter or spectrum analyzer, and a standard TV receiver to measure signal levels and check picture quality at all TV outlets.
    - a. Test the signal strength in dBmV at 55 and 750 MHz.
    - b. Minimum acceptable signal level is 0 dBmV (1000 mV).
    - c. Maximum acceptable signal level over the entire bandwidth is 12 dBmV.
    - d. Television receiver shall show no evidence of cross-channel intermodulation, ghost images, or beat interference.
- G. Qualitative and Quantitative Performance Tests: Demonstrate reception quality of color-television program transmissions at each user interface from each designated channel and source. Quality shall be equal to or superior than that obtained with performance checks specified below, using a standard, commercial, cable-ready, color-television receiver. Level and quality of signal at each outlet and from each designated channel and source shall comply with the following Specifications when tested according to 47 CFR 76:
  - 1. RF video-carrier level.
  - 2. Relative video-carrier level.
  - 3. Broadband frequency response.
  - 4. Channel frequency response.
  - 5. Carrier-to-noise ratio.
  - 6. RF visual signal-to-noise ratio.
  - 7. Cross modulation.
  - 8. Terminal isolation.
  - 9. Hum modulation.
- H. Record test results.
- I. Retest: Correct deficiencies identified by tests and observations and retest until requirements specified in Part 1 are met.

### 3.7 DEMONSTRATION

- A. Engage a factory-authorized service representative to train Owner's maintenance personnel to adjust, operate, and maintain MATV equipment.
  - 1. Train Owner's maintenance personnel on procedures and schedules for troubleshooting, servicing, and maintaining equipment.
  - 2. Demonstrate methods of determining optimum alignment and adjustment of components and settings for system controls.

3. Demonstrate programming and tuning of satellite receivers.
  4. Refer to Division 01 Section "Demonstration and Training."
- B. Conduct a minimum of four hours' training as specified in instructions to Owner's employees in Division 01 Section "Demonstration and Training."

**END OF SECTION**

## SECTION 275113

## OVERHEAD PAGING

## PART 1 - GENERAL

## 1.1 RELATED DOCUMENTS

- A. The Primary Division 27 subcontractor shall be accountable to closely coordinate the Overhead Paging system with the General Contractor.
  - 1. Division 27 is accountable for including the cabling, equipment, and installation thereof in their work; based upon the project drawings.
- B. Drawings and general provisions of Contract, including General and Supplementary Conditions and Division 1 Specification Sections, apply to this Section.
- C. Requirements of the following Division 26 Sections apply to this Section:
  - 1. Basic Electrical Requirements.
  - 2. Basic Electrical Materials and Methods.

## 1.2 SUMMARY

- A. This Section includes the installation of an overhead paging system that shall be accessible through the telephone system. It includes requirements for paging system components including, but not limited to, the following:
  - 1. Speaker systems.
  - 2. Wiring
- B. This section requires that rough-in materials for this section be provided by the Division 26 installer for installation under Division 26. Rough-in materials include but are not limited to conduit, junction boxes, alternative raceway, and device enclosures. Cable for this section is to be provided by the Division 27 installer.

## PART 2 - PRODUCTS

## 2.1 MANUFACTURERS

- A. Manufacturers: Subject to compliance with requirements, provide products by one of the following (for each type of product) as listed in the drawings and these specifications:
  - 1. BiAmp

## 2.2 SYSTEM REQUIREMENTS

- A. General: Provide complete and fully functional overhead paging systems using materials and equipment of types, sizes, ratings, and performances as indicated. Use materials and equipment that comply with referenced standards and manufacturers' standard design and construction in accordance with published product information. Coordinate the features of materials and equipment so they form an integrated system with components and interconnections matched for optimum performance of specified functions.

## 2.3 EQUIPMENT AND MATERIALS

- A. General: Provide all solid-state components fully rated for continuous duty at the ratings indicated or specified. Select equipment for normal operation on input power supplied at 105-130 V, 60 Hz.

- B. Loudspeakers shall be Drop-In Tile speakers. To be 24" x 24" tile speakers, provided by one of the following manufactures.
  - 1. Bogen CSD2X2/VR
  - 2. Quam System 12/70RS
- C. Transformer must be capable of providing 25V/70V.

### PART 3 - EXECUTION

#### 3.1 EXAMINATION

- A. Examine conditions, with the Installer present, for compliance with requirements and other conditions affecting the performance of the Overhead Paging System work.
- B. Do not proceed until unsatisfactory conditions have been corrected.
- C. Verify compliance of the following items before beginning sound equipment installation.
  - 1. No cables spliced except at standard barrier terminal blocks inside equipment cabinet.
  - 2. Cables marked at each end with permanent wire labels such as Brady or equal.
  - 3. Isolated ground run back to main electrical panel from paging equipment cabinet.
  - 4. Specified conduit, cables, speaker enclosures and equipment cabinets are properly installed.

#### 3.2 INSTALLATION

- A. General: Install system in accordance with NFPA 70 and other applicable codes. Install equipment in accordance with manufacturer's written instructions.
- B. Speakers:
  - 1. Confirm polarity of speaker before installation and wire to maintain uniform polarity.
  - 2. Mount transformers with screws securely to speaker brackets or enclosures.
  - 3. Neatly mount speaker grilles, panels, connector plates, etc., tight, plumb, and square unless indicated otherwise on drawings.
  - 4. Provide brackets, screws, adapters, springs, rack mounting kits, etc., recommended by manufacturer for correct assembly and installation of speaker assemblies and electronics components.
  - 5. Identification:
    - a. Legibly identify user operated system controls and system input/output jacks using engraved, permanently attached laminated plastic plates or imprinted Lexon labels. Label equipment and controls within equipment cabinet using similar labels or "Kroy" type labels.
- C. Repairs: Wherever walls, ceilings, floors, or other building finishes are cut for installation, the contractor shall be responsible to repair, restore, and refinish to original appearance.

#### 3.3 FIELD QUALITY CONTROL

- A. Manufacturer's Field Services: Provide services of a factory authorized service representative to supervise the field assembly and connection of components and the pre-testing, testing, and adjustment of the system.
- B. Pre-testing: Upon completing installation of the system, align, adjust, and balance the system and perform a complete pretest. Determine the conformance of the system to the requirements of the Drawings and Specifications. Correct deficiencies observed. Replace malfunctioning or damaged items with new, and retest until materials satisfactory performance and conditions are achieved.

3.4 COMMISSIONING

- A. Occupancy Adjustments: When requested by the Architect or the Sound/Acoustical Consultant within one year of date of substantial completion, provide on-site assistance in adjusting sound levels, resetting matching transformer taps, and adjusting controls to suit actual occupied conditions. Provide two trips for this purpose.

3.5 CLEANING AND PROTECTION

- A. Prior to final acceptance, clean system components and protect from damage and deterioration.

END OF SECTION

---

SECTION 275319

INTERNAL CELLULAR, PAGING  
AND ANTENNA SYSTEMS

PART 1 - GENERAL

1.1 RELATED DOCUMENTS

- A. Drawings and general provisions of Contract, including General and Supplementary Conditions and Division 1 Specification Sections, apply to this Section.
- B. Requirements of the following Division 26 Sections apply to this Section:
  - 1. Basic Electrical Requirements.
  - 2. Basic Electrical Materials and Methods.

1.2 SUMMARY

- A. The DAS system is provided and installed as an Owner-provided, Owner installed (OFOI) system by a 3<sup>rd</sup>-party vendor, contracted and managed by Intermountain CTIS/Telecom Team.
- B. A/E to coordinate DAS requirements with the Owner's vendor to incorporate necessary infrastructure on their drawings to support a fully functional DAS system.

PART 2 - EXECUTION

2.1 INSTALLATION

- A. DAS contractor is to install their equipment located in the TDRs in the assigned rack location as noted in the ET Rack Elevation Drawings.
- B. DAS contractor is to install any wall mounted equipment in the TDRs in the assigned location as noted in the ET TDR Room Elevation drawings.
- C. Specific power requirements will need to be provided in the design phase of the project by the CTIS/Telecom team.
- D. Cable installation will follow Division 27 installation specifications.

END OF SECTION

---

## SECTION 276001

### APPENDIX 01 – DEVIATION REQUEST PROCESS

#### PART 1 - GENERAL

##### 1.1 DEFINITIONS

- A. Cable Plant Deviation
  - 1. A business need to not fully comply with the requirements of the “Division 27 – Communications and Structured Cabling Specification document”
- B. Cable Plant Deviation Request form.
  - 1. The document is available from the Facilities Planning team, the Data Center Ops team, or the Infrastructure Cabling team.
  - 2. Usage:
    - a. The deviation request form shall be used if there is a business need to not comply with the requirements of the “Division 27 – Communications and Structured Cabling Specification document”
    - b. The deviation request form should also be used to propose a change to that document. Always verify that you are using the current version of the Standard before requesting a modification.

#### PART 2 - PROCESS

##### 2.1 STANDARDS MODIFICATION

- A. Check the box and explain why the standard should be modified.

##### 2.2 ALTERNATE PRODUCT

- A. The deviation form must be completed, submitted through channels, and approved prior to any deviation from the specifications. This includes issuing change orders.

##### 2.3 AUTHORIZED SIGNATURES

- A. Both the Standards Holder and the DCO Manager signatures are required for a deviation to be valid.

##### 2.4 DEVIATION REVIEW PROCESS STEPS

- A. First be sure that there is an actual need. Then be certain that your manager, supervisor, or project manager agrees with the requested deviation. Be sure to state this or obtain their signature on the deviation form. By doing so you are confirming that your supervisor or project manager has approved.
- B. The requestor will then complete sections 1, 2, and 3 of the deviation form.
  - 1. The requestor should then digitally sign in the designated location at the end of Section 3. Do not write in the sections below 3.
- C. Forward the saved copy of this form to the Standards Holder via email.
  - 1. Email to: [melissa.lopez2@imail.org](mailto:melissa.lopez2@imail.org)
- D. The Standards Holder will then review and evaluate the request. The requestor should be prepared to provide plans, specifications, and competitive bids if requested. Any email threads or meeting discussions regarding the issue will be taken into consideration.



- E. The Standards Holder will then cast an Approve or Deny vote and forward the request to the DCO Manager for a decision.
- F. When the decision has been made by the Operations Manager, the Standards Holder will then notify the requestor by returning the completed and signed form via email.
- G. An approved deviation will have the final disposition button 'Approved' and be signed by at least 2 people. One will be from the Standards Holder, and the other the DCO Manager. Other signatures may be required for specific features and areas such as Safety, Security, Print, Medical group, etc.

### PART 3 - EXECUTION

#### 3.1 POST DECISION EXECUTION

- A. DENIED
  - 1. If the requester is not satisfied with the decision, they may file an appeal with the Data Center Operations manager (shawn.folkman@imail.org), who will then escalate the issue to the appropriate business leaders as needed. The decision from the appeal is final.
- B. APPROVED
  - 1. If a deviation is approved for contracted material, labor, or method; the facilities project manager will arrange for fulfillment or contract adjustment as needed via appropriate contract channels such as change orders.

END OF SECTION

---

SECTION 276002

APPENDIX 02 – DOCUMENT  
REFRESH PROCESS

PART 1 - GENERAL

1.1 NOT USED

PART 2 - PRODUCTS

2.1 APPROVED PRODUCT

- A. The purpose of this section is to help ensure a current standards document.
- B. The product delivered will be a current revision or version of the Cable Plant Standards Document.
- C. All changes must be approved by Enterprise Infrastructure Cabling team.

PART 3 - EXECUTION

3.1 REVIEWS AND UPDATES

A. Minor updates

- 1. Changes that do not significantly affect scope of work, or contract pricing will be made, and the Rev number will be updated. (i.e. updated part numbers, etc.)
- 2. Significant changes will be added to the Change Log for review and approval from the DCO/Infrastructure Cabling Team.
  - a. When approved, they will be submitted for approval; and then implemented in the new Version.

B. Major updates

- 1. The DCO/Infrastructure Cabling Team will review the entire document at least once every three years.
- 2. This review will coincide with the release of new versions of NFPA70 (National Electrical Code) (2017, 2020, etc. - to be completed by the end of each designated year).
- 3. The review will cover standards adjustments that may be deemed necessary and ensure compliance with applicable codes and standards.
- 4. Upon completion of the reviews and updates, the standards document will be submitted for approval.

END OF SECTION

## SECTION 276003

## APPENDIX 03 – DATA CENTER, TEC, TDR PART NUMBERS

ITEM	MANUFACTURER	PART NO.	DESCRIPTION
Blanking Panel	Upsite Hotlok	10031	Blanking Panel 1U
Blanking Panel	Upsite Hotlok	10033	Blanking Panel 2U
UPS	Eaton	9PX1500R	Eaton Powerware 9PX-1500V
UPS Network Card	Eaton	NETWORK-M	Card for 9PX-1500VA
PDU	Eaton	ePBZ79	Horizontal Mount ePDU 208vac
PDU	Eaton	ePBZ82	Horizontal Mount ePDU 120vac
PDU	Server Technology	C1S24VS-YCFA13C9	Vertical 30A PDU (Blue) for TEC
PDU	Server Technology	C1L24VS-YCFA13C9	Vertical 30A PDU (Red) for TEC
PDU	Server Technology	C2SG36TE-YCMFAM66/C	Vertical 30A PDU (Blue) for Data Centers
PDU	Server Technology	C2LG36TE-YCMFAM66/C	Vertical 30A PDU (Red) for Data Centers
PDU	Server Technology	C2SG36TE-DQME2M66/ZB	Vertical 60A PDU (Blue) for Data Centers
PDU	Server Technology	C2LG36TE-DQME2M66/ZR	Vertical 60A PDU (Red) for Data Centers
UPS	Eaton	K41512000000000	Eaton 9155-15kVA UPS
Modbus Card	Eaton	103005425-5591	Eaton Modbus Card X-Slot
Reverse Transfer UPS System	Eaton	9GPV15C0009E00R2	Eaton 93PM-150kW Reverse Transfer UPS System
CRAC Cooling Unit	Liebert	DE363G	
Vertical Wall Mount Cabinets	Legrand	VWMSD-4RU-42-B	42" 12" 4RU Fixed
Vertical Wall Mount Cabinets	Legrand	VWMSD-8RU-42-B	42" 18" 8RU Fixed
Rail Accessories	Legrand	VWM-RR-4RU	Fixed Mounting Rail Kit, 4RU
Rail Accessories	Legrand	VWM-RR-8RU	Fixed Mounting Rail Kit, 8RU
Rail Accessories	Legrand	VWM-PIV-4RU	Pivoting Mounting Rail Kit, 4RU
Fan Kit	Legrand	VWMFK-115	VWM Fan Kit w/115 VAC Fans (includes 2 fans and mounting hardware) (2 kits needed for 8RU cabinet)
VWM Top Brush Grommet Kit	Legrand	VWMBGK	VWM Top Brush Grommet Kit
Circular Knockout Grommet Kit	Legrand	VWMGR-30	Circular Knockout Grommet Kit
Vertical Wall-Mount Cabinets	Hubbell	IR221APG	Refrigerated cabinet 24"
Vertical Wall-Mount Cabinets	Hubbell	IR321APG	Refrigerated cabinet 36"
Vertical Wall-Mount Cabinets	Hubbell	IR421APG	Refrigerated cabinet 48"
Air Conditioners	Hubbell	IRAC1	Air conditioner for Hubbell refrigerated cabinets
Cylinder	Medeco	100500 G	1 ¼" Mortise Cylinder
Cylinder	Medeco	100400H G	Rim Cylinder, Horizontal Tailpiece
Cylinder	Medeco	EA-100108	Small Format Interchangeable Core (SFIC) Cylinder
Cylinder	Medeco	20200S1 G	Cylinder Package for Schlage

Cam Lock	Medeco	EN-150002-219	7/8" Cam Lock Assembly, Key Retaining
Cam Lock	Medeco	EN-150003-219	1 1/8" Cam Lock Assembly, Key Retaining
Cylinder for Legrand cabinet front door	Medeco	232301S 800 G	Modular Profile Cylinder – 30mm Half Profile - Assembled
Electronic Key	Medeco	94-0271	Medeco Slim Line Key (G2) & Charger Bundle
Programming Station for Small Locations	Medeco	EA-100109	Medeco XT Desktop USB Programming Station (not preferred)
Programming Station for Large Locations	Medeco	EA-100158	Medeco XT Wall USB Programming Station (preferred)
Wall Mount for Wall Programmer	Medeco	94-0294	Medeco XT Remote Wall Programmer Wall Mount Kit
Padlock for use with Electronic Cylinder	Master	6842D045KZ	Padlock
Red C20 C19 Dual Lock 12 gauge 6'	Stay Online	5914	Red C20 C19 Dual Lock 12 gauge 6'
Blue C20 C19 Dual Lock 12 gauge 6'	Stay Online	6766	Blue C20 C19 Dual Lock 12 gauge 6'
Red C14 Locking C15 Notched 14 gauge 6'	Stay Online	9144	Red C14 Locking C15 Notched 14 gauge 6'
Blue C14 Locking C15 Notched 14 gauge 6'	Stay Online	9138	Blue C14 Locking C15 Notched 14 gauge 6'
Red C14 C13 Dual Lock 18 gauge 6'	Stay Online	5656	Red C14 C13 Dual Lock 18 gauge 6'
Blue C14 C13 Dual Lock 18 gauge 6'	Stay Online	6694	Blue C14 C13 Dual Lock 18 gauge 6'

## SECTION 276004

## APPENDIX 04 – REFERENCE STANDARDS

## PART 1 - GENERAL

## 1.1 REFERENCE STANDARDS

- A. Codes and Standards (Most recent editions with addenda/TSB, etc.) All materials, installation and workmanship shall meet or exceed the applicable requirements and standards addressed within the references listed below:
1. ANSI/TIA-568.0-D and addenda "Generic Telecommunications Cabling for Customer Premises
  2. ANSI/TIA-568.1-D and addenda "Commercial Building Telecommunications Cabling Standard
  3. ANSI/TIA-568.2-D and addenda "Balanced Twisted-Pair Telecommunications Cabling and Components
  4. ANSI/TIA-568.3-D and addenda "Optical Fiber Cabling Components Standard"
  5. ANSI/TIA-568.4-D and addenda "Broadband Coaxial Cabling and Components Standard"
  6. ANSI/TIA-569-D and addenda "Telecommunications Pathways and Spaces"
  7. ANSI/TIA-606-C and addenda "Administration Standard for Commercial Telecommunications Infrastructure"
  8. ANSI/TIA-607-D and addenda "Generic Telecommunications Bonding and Grounding (Earthing) for Customer Premises"
  9. ANSI/TIA-758-B "Customer-Owned Outside Plant Telecommunication Infrastructure Standard"
  10. IEEE 802.3at PoE Plus and Next Gen PoE CFI March 2013 and IEEE P802.3ba latest draft revision and amendments.
  11. "Media Access Control Parameters, Physical Layers and Management Parameters for 40 Gbp/s and 100 Gbp/s Operation".
  12. ANSI/TIA-526-7-A "Measurement of Optical Power Loss of Installed Single-Mode Fiber Cable Plant"
  13. ANSI/TIA/EIA-526-14-C "Optical Power Loss Measurements of Installed Multimode Fiber Cable Plant"
  14. ANSI/TIA-942-B "Telecommunications Infrastructure Standard for Data Centers"
  15. ANSI/TIA – 1179-A "Healthcare Facility Telecommunications Infrastructure Standard"
  16. IEC/TR3 61000-5-2 - Ed. 1.0 and amendments "Electromagnetic compatibility (EMC) - Part 5: Installation and mitigation guidelines - Section 2: Earthing and cabling"
  17. ISO/IEC 11801-1 (2017) and amendments "Information technology - Generic cabling for customer premises – PART 1: General Requirements"
  18. EN 50173-1 and amendments "Information Technology - Generic cabling systems – PART 1 General Requirements"
  19. AIA Guidelines for Design and Construction of Hospital and Healthcare Facilities
  20. Construction Specification Institute Master Format
  21. BICSI: Comply with the most current editions of the following BICSI manuals:
    - a. BICSI - Telecommunications Distribution Methods Manual
    - b. BICSI – Installation Transport Systems Information Manual
    - c. BICSI – Network Design Reference Design Manual
    - d. BICSI – Outside Plant Design Reference Manual
    - e. BICSI – Wireless Design Reference Manual

- f. BICSI -Electronic Safety and Security Design Reference Manual
- g. Infocomm/BICSI – AV Design Reference Manual
- 22. Underwriters Laboratories (UL) Cable Certification and Follow-Up Program.
- 23. National Electrical Manufacturers Association (NEMA)
- 24. American Society for Testing Materials (ASTM)
- 25. National Electrical Code (NEC) NFPA70 2020
- 26. National Electrical Safety Code (NESC) 2017
- 27. Institute of Electrical and Electronic Engineers (IEEE)
- 28. UL Testing Bulletin
- 29. Building Industry Consulting Services International (BICSI) Information Transport Systems Methods Manual (ITSMM)
- 30. Local, county, state and federal regulations and codes in effect as of date of installation.
- 31. Equipment of foreign manufacture must meet U.S. codes and standards. It shall be indicated in the proposal the components that may be of foreign manufacture, if any, and the country of origin.

END OF SECTION

## SECTION 276005

## APPENDIX 05 – DEFINITIONS AND ABBREVIATIONS

## PART 1 - GENERAL

## 1.1 RELATED TERMS

- A. Codes and Standards (Most recent editions with addenda/TSB, etc.) All materials, installation and workmanship shall meet or exceed the applicable requirements and standards addressed within the references listed below:
1. Basket Cable Tray: A fabricated structure consisting of wire mesh bottom and side rails.
  2. BICSI: Building Industry Consulting Service International.
  3. CBC: Coupled Bonding Conductor
  4. CFCI: Customer Furnished Customer Installed
  5. Cable Run - A single cable to a single location
  6. Cable Drop - Two cables to a single location
  7. Cable Tri Drop - Three cables to a single location
  8. CT Coupler A type of wall connector made by the Siemon Company
  9. DCO: Data Center Operations
  10. Div. 1: Division 1 General and Performance Requirements
  11. Div. 23: Division 23 Heating, Ventilating, and Air Conditioning
  12. Div. 22: Division 22 Plumbing
  13. Div. 26: Division 26 Electrical
  14. Div. 27: Division 27 Communications and Audio Visual
  15. Div. 28: Division 28 Electronic Safety and Security
  16. E.E.: Electrical Engineer
  17. EMI: Electromagnetic Interference
  18. F/UTP: Foil over Unshielded Twisted Pair. Individual pairs are unshielded.
  19. GC: General Contractor
  20. GE: Ground Equalizer
  21. Horizontal Cabling: The cable and connecting hardware utilized to transport communications signals
  22. ICT: Infrastructure Cabling Team
  23. LAN: Local Area Network
  24. N/A: Not Applicable
  25. NIC: Not in Contract
  26. OFCI: Owner Furnished Contractor Installed
  27. OFOI: Owner Furnished Owner Installed
  28. OTDR: Optical Time Domain Reflectometer
  29. Outlet/Connectors: A connecting device in the work area on which horizontal cable or outlet cable terminates.
  30. RCDD: Registered Communications Distribution Designer
  31. RFI: Radio Frequency Interference
  32. TBA or TBD: To Be Determined
  33. TDR: Technology Distribution Room
  34. TEC: Technology Equipment Center
  35. TGB: Telecommunications Ground Bus Bar
  36. TMBC: Telecommunications Main Bonding Conductor
  37. TMGB: Telecommunications Main Grounding Bus Bar
  38. TSER: Telecommunications Service Entrance Room
  39. UTP: Unshielded Twisted Pair
  40. Work Area: approx. 100 sq. ft. equipped for workstation equipment

- 41. DCO = Data Center Operations – [Boe.Sausedo@imail.org](mailto:Boe.Sausedo@imail.org)
- 42. ICT = Information and Communications Technology – [Melissa.Lopez2@imail.org](mailto:Melissa.Lopez2@imail.org)

END OF SECTION





## SECTION 276007

APPENDIX 07 – SIEMON CERTIFIED  
INSTALLATION FIRMS

## PART 1 - GENERAL

## 1.1 RELATED TERMS

- A. NOTE: Cable installers have rigorous requirements to be certified for Siemon cables and products. Validation of certification is required prior to accepting a bid.
- B. The firms selected to bid must be pre-approved by the local facility IT manager. Installation firms desiring to do work for Intermountain Healthcare must be selected from the official CI list below.
- C. Current Siemon Approved/Certified Cable Installers for Siemon Network Cable. This list is up to date as of 2018-12-01.
1. **Orion Integration Group:** 8880 W. Barnes Street, Boise, ID 83709 / Phone 208 321 8000
  2. **ACS Systems:** 925 North Main St. Meridian, ID 83642 / Phone 208 331 8554
  3. **IES Commercial:** 1960 S. Milestone, Suite D, Salt Lake City, UT 84104
    - a. Jason King – Branch Manager // Phone 801 975 8182 / Fax 385 242 7366 / Mobile 801 381 1508 // [Jason.King@iescomm.com](mailto:Jason.King@iescomm.com) / [www.iescomm.com](http://www.iescomm.com)
    - b. Boyd Evans – Project Manager // Phone 801 975 8191 / Fax 385 242 7366 / Mobile 801 381 1518 // [Boyd.Evans@iescomm.com](mailto:Boyd.Evans@iescomm.com) / [www.iescomm.com](http://www.iescomm.com)
  4. **Cache Valley Electric:** 1338 S. Gustin Rd., Salt Lake City, UT 84104
    - a. Travis Grant – Acct. Manager // Phone 801 908 4170 / Fax 801 908 7401 / Mobile 801 870 7226 // [Travis.Grant@cve.com](mailto:Travis.Grant@cve.com) / [www.cve.com](http://www.cve.com)
    - b. Brad Readicker – Acct. Manager // Phone 801 908 2686 / Fax 801 908 7401 // [Brad.Readicker@cve.com](mailto:Brad.Readicker@cve.com) / [www.cve.com](http://www.cve.com)
  5. **Data Tech Professionals:** 1199 S 520 W, Payson, UT 84651
    - a. Jesse Pierce – President // Phone 801 960 2202 / Mobile 801 420 0463 // [Jesse@datatechprofessionals.com](mailto:Jesse@datatechprofessionals.com) / [www.datatechprofessionals.com](http://www.datatechprofessionals.com)
  6. **Hunt Electric, Inc.:** 1863 W. Alexander St., Salt Lake City, UT 84119
    - a. Darrin Guevara – Division Manager // Phone 801 975 8844 // [Darrin@huntelelectric.com](mailto:Darrin@huntelelectric.com) / [www.huntelelectric.com](http://www.huntelelectric.com)
  7. **NCNS Communications:** 419 West Universal Circle, Sandy, UT 84070
    - a. Jayson Nosack – Owner // Phone 801 361 4572 // [Jnosack@ncns-co.com](mailto:Jnosack@ncns-co.com) / [www.ncns-co.com](http://www.ncns-co.com)
  8. **Data Plus:** 769 Middlegate Road, Henderson, NV 89118
    - a. Chris Tettamanti – Project Manager // Phone 702 795 3282 // [Chris@dpcnv.com](mailto:Chris@dpcnv.com)
  9. **Bombard Electric:** 4380 West post Road, Las Vegas, NV 89118
    - a. Bob Reese – Project/Division Manager // Phone 702 263 3570 // [Bob.reese@bombardelec.com](mailto:Bob.reese@bombardelec.com) / [www.bombardelectric.com](http://www.bombardelectric.com)
  10. **Rosendin Electric:** 7470 Dean Martin Dr. #112, Las Vegas, NV 89139
    - a. Cora Shadbolt – Assistant Project Mgr. // Phone 702 258 1443 // [cshadbolt@rosendin.com](mailto:cshadbolt@rosendin.com)
    - b. Adrian Youngblood – Sr. Estimator // Phone 702 258 1455 // [ayoungblood@rosendin.com](mailto:ayoungblood@rosendin.com)
    - c. Breck Hardesty – Sr. Project Mgr. // Phone 702 258 1428 // [bhardesty@rosendin.com](mailto:bhardesty@rosendin.com) / [www.rosendin.com](http://www.rosendin.com)
  11. **Mojave Electric:** 3755 W. Hacienda Ave., Las Vegas, NV 89118 / Phone 702 798 2970

12. **The Morse Group:** 3874 Silvestri Lane, Las Vegas, NV 89120  
Phone 702 257 4400

END OF SECTION

SECTION 276008

APPENDIX 08 – LEAD WALL PENETRATIONS

PART 1 - GENERAL

1.1 RELATED DOCUMENTS

- A. Sections 13090 & 134900

1.2 RELATED TERMS

**Procedure Name:** New Port and Electrical Box Installation Lead Lined Walls

**Document Detail Information: (This section must be completed in full.)**

<b>Implements Policy:</b>	Click here to enter policy title		
<b>Content Owner</b>	Craig Allen, Safety Security Environment Health Director, Central Office Jeremy Hawk Medical Physicist Radiation Safety Coordinator	<b>Content Consultant(s):</b>	Jeremy Hawk, Radiation Safety Officer, Medical Physicist Imaging  John Ellis, Facilities Management Director, Central Office Steve Kelly, System Project Facility Design Manager, Planning Melissa Lopez, Cabling, IS
<b>Date of Final Draft:</b>	12/29/2015	<b>Who Reviewed Content?</b>	<Name, Title, Dept> <Name, Title, Dept> <Name, Title, Dept> <Committee Name>
<b>Keywords (must have at least 3):</b>	Searchable Keywords (e.g., PHI, EMTALA, Coding)		

1.3 PURPOSE

- A. Maintain radiation safety controls in lead lined walls during installation of new power and data outlets in existing lead lined walls.

1.4 SCOPE

- A. Intermountain Hospitals, Intermountain Clinics Medical Group

1.5 DEFINITIONS

- A. Lead lined Walls – Structured element designed to provide a barrier to block radiation penetration beyond the designated space.

- B. Maintenance Manager – The person responsible for plant maintenance operations or his/her delegate.
- C. Radiation Safety Coordinator – The person responsible for Radiation Safety or his/her Delegate. Medical Physicist.
- D. Worker – The person responsible for completing work with the lead lined wall. This includes Intermountain Employees as well as any outside supplier or contractor.

## 1.6 PROVISIONS

- A. The Radiation Safety Program is following Utah regulation R313-15-101, R313-28 and U.S. Nuclear Regulatory Commission Regulation 1- CFR Part 20-1101.

## 1.7 PROCEDURE

- A. Prior to any work within a lead lined wall, the Worker reports to the Radiation Safety Coordinator, Maintenance Manager and completed a review of planned work “ACWP” Identification of specific description related to the lead lined wall planned work.
  - 1. Intermountain workers, outside suppliers or contractors hired to work in any Intermountain facility must contact the Maintenance Manager and Radiation Safety Coordinator prior to beginning work to discuss the project and ensure that the planned work will not interfere with facility operations, maintenance, or other projects.
  - 2. Failure to scheduled and complete the planning meeting described above may results in the delay or rescheduling of work. Outside suppliers or contractors are responsible for any costs incurred because of their failure to schedule and complete this meeting.
- B. The Radiation Safety Coordinator, Maintenance Manager and the worker conduct a pre-work inspection of the areas in which work is to be performed. This inspection identified the following:
  - 1. Areas of special concern or sensitivity, including those noted or described on the facility Life Safety records and drawings, and Radiation Safety records and drawings.
  - 2. Appropriate areas or structures to use for support of any work, as applicable.
  - 3. Existing deficiencies in Barriers.
  - 4. The as act assemblies impacted by the work.
  - 5. The type of shielding material acceptable in the area.
    - a. Lead lined boxes
    - b. Lead lined wall “inside wall” installation, and OR
    - c. Lead shielding for wall installation of “outside wall” maintaining radiation safety barriers.
  - 6. The exact condition of the areas upon completion of work.
- C. Upon completion of the work and before closing the wall, the worker, Radiation Safety Coordinator and Maintenance Manager conduct a post-work inspection of the area in which the work was performed, this inspection verifies the following:
  - 1. No Tools, Supplies or debris are left within the walls.
  - 2. Lead lining is installed to maintain radiation safety protection according to regulatory requirements.
  - 3. All work affecting Radiation Safety Lead Barriers has been properly sealed.
  - 4. The overall condition of the area meets the expectation outline in the per-work inspection.
- E. The Maintenance Manager and Radiation Safety Coordinator signs and logs the completed “ACWP”

1.8 EXCEPTIONS

- A. None.

1.9 PRIMARY SOURCES

- A. List the regulatory references upon which the procedure is based (cite the code, the title, and the statute).

1.10 SECONDARY MATERIALS

- A. Radiation Safety Policy
- B. Above Ceiling Work Permit
- C. Lead lined wall requirements as defined by Radiation Safety Building Requirements



Option 1: worker to install new power utility wall box and add Lead Lining to wall behind box  
If worker can access posterior wall entry



Option 2: worker to install new power utility wall box – box is lead Lined by manufacturer



Option 3: worker to install new power utility wall box - no additional lead lining required if installation does not disrupt the existing shielding

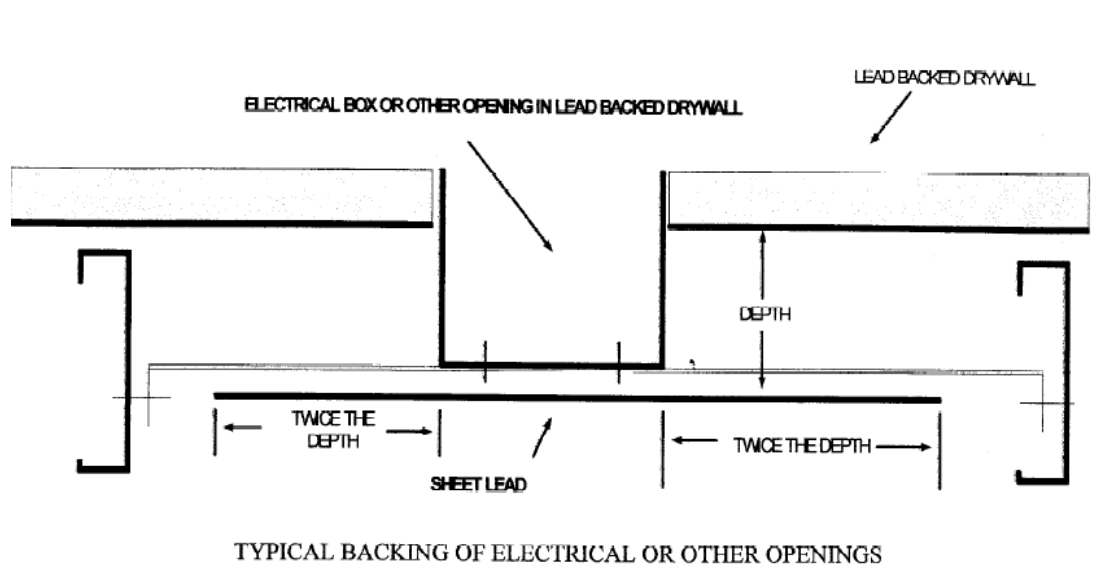

END OF SECTION

**SECTION 28 31 11**  
**DIGITAL, ADDRESSABLE FIRE-ALARM SYSTEM**

**PART 1 - GENERAL**

**1.1 RELATED DOCUMENTS**

- A. Drawings and general provisions of the Contract, including General and Supplementary Conditions and Division 01 Specification Sections, apply to this Section.

**1.2 SUMMARY**

- A. Section Includes:
1. Fire-alarm control unit.
  2. Manual fire-alarm boxes.
  3. System smoke detectors.
  4. Nonsystem smoke detectors.
  5. Heat detectors.
  6. Notification appliances.
  7. Firefighters' two-way telephone communication service.
  8. Magnetic door holders.
  9. Remote annunciator.
  10. Addressable interface device.
  11. Digital alarm communicator transmitter.
  12. Radio alarm transmitter.
  13. System printer.

**1.3 DEFINITIONS**

- A. LED: Light-emitting diode.
- B. NICET: National Institute for Certification in Engineering Technologies.

**1.4 SYSTEM DESCRIPTION**

- A. Noncoded, UL-certified FMG-placarded addressable system, with automatic sensitivity control of smoke detectors and multiplexed signal transmission, dedicated to fire-alarm service only.

**1.5 PERFORMANCE REQUIREMENTS**

- A. Seismic Performance: Fire-alarm control unit and raceways shall withstand the effects of earthquake motions determined according to SEI/ASCE 7.
1. The term "withstand" means "the unit will remain in place without separation of any parts from the device when subjected to the seismic forces specified."

**1.6 ACTION SUBMITTALS**

- A. Product Data: For each type of product indicated.
- B. Shop Drawings: For fire-alarm system, submit shop drawings with product data in one submittal. Include plans, elevations, sections, details, and attachments to other work.
1. Comply with recommendations in the "Documentation" Section of the "Fundamentals of Fire Alarm Systems" Chapter in NFPA 72.
  2. Include voltage drop calculations for notification appliance circuits.
  3. Include fire alarm zoning diagrams indicating zoning of the fire alarm system coordinated with the corresponding fire protection zones and smoke compartments. Comply with NFPA 99.
  4. Include battery-size calculations.
  5. Include performance parameters and installation details for each detector, verifying that each detector is listed for complete range of air velocity, temperature, and humidity possible when air-handling system is operating.



6. Include plans, sections, and elevations of heating, ventilating, and air-conditioning ducts, drawn to scale and coordinating installation of duct smoke detectors and access to them. Show critical dimensions that relate to placement and support of sampling tubes, detector housing, and remote status and alarm indicators. Locate detectors according to manufacturer's written recommendations. Provide remote test switches (RTS) as required by NFPA 72.
  7. Include voice/alarm signaling-service equipment rack or console layout, grounding schematic, amplifier power calculation, and single-line connection diagram.
  8. Include floor plans to indicate final outlet locations showing address of each addressable device. Show size and route of cable and conduits.
- C. General Submittal Requirements:
1. Submittals shall be approved by authorities having jurisdiction prior to submitting them to Architect.
  2. Shop Drawings shall be prepared by persons with the following qualifications:
    - a. Trained and certified by manufacturer in fire-alarm system design.
    - b. NICET-certified fire-alarm technician, Level III minimum.
    - c. Licensed or certified by authorities having jurisdiction.
- D. Delegated-Design Submittal: For smoke and heat detectors indicated to comply with performance requirements and design criteria, including analysis data signed and sealed by the qualified professional engineer responsible for their preparation.
1. Drawings showing the location of each smoke and heat detector, ratings of each, and installation details as needed to comply with listing conditions of the detector.
  2. Design Calculations: Calculate requirements for selecting the spacing and sensitivity of detection, complying with NFPA 72.

## 1.7 INFORMATIONAL SUBMITTALS

- A. Qualification Data: For qualified Installer.
- B. Seismic Qualification Certificates: For fire-alarm control unit, accessories, and components, from manufacturer.
1. Basis for Certification: Indicate whether withstand certification is based on actual test of assembled components or on calculation.
  2. Dimensioned Outline Drawings of Equipment Unit: Identify center of gravity and locate and describe mounting and anchorage provisions.
  3. Detailed description of equipment anchorage devices on which the certification is based and their installation requirements.
- C. Field quality-control reports.

## 1.8 CLOSEOUT SUBMITTALS

- A. Operation and Maintenance Data: For fire-alarm systems and components to include in emergency, operation, and maintenance manuals. In addition to items specified in Section 017823 "Operation and Maintenance Data," include the following:
1. Comply with the "Records" Section of the "Inspection, Testing and Maintenance" Chapter in NFPA 72.
  2. Provide "Record of Completion Documents" according to NFPA 72 article "Permanent Records" in the "Records" Section of the "Inspection, Testing and Maintenance" Chapter.
  3. Record copy of site-specific software.
  4. Provide "Maintenance, Inspection and Testing Records" according to NFPA 72 article of the same name and include the following:
    - a. Frequency of testing of installed components.
    - b. Frequency of inspection of installed components.
    - c. Requirements and recommendations related to results of maintenance.
    - d. Manufacturer's user training manuals.
5. Manufacturer's required maintenance related to system warranty requirements.

6. Abbreviated operating instructions for mounting at fire-alarm control unit.
- B. Software and Firmware Operational Documentation:
1. Software operating and upgrade manuals.
  2. Program Software Backup: On magnetic media or compact disk, complete with data files.
  3. Device address list.
  4. Printout of software application and graphic screens.
- 1.9 MAINTENANCE MATERIAL SUBMITTALS**
- A. Furnish extra materials that match products installed and that are packaged with protective covering for storage and identified with labels describing contents.
1. Lamps for Remote Indicating Lamp Units: Quantity equal to 10 percent of amount installed, but no fewer than 1 unit.
  2. Lamps for Strobe Units: Quantity equal to 10 percent of amount installed, but no fewer than 1 unit.
  3. Smoke Detectors, Fire Detectors: Quantity equal to 10 percent of amount of each type installed, but no fewer than 1 unit of each type.
  4. Detector Bases: Quantity equal to 2 percent of amount of each type installed, but no fewer than 1 unit of each type.
  5. Keys and Tools: One extra set for access to locked and tamperproofed components.
  6. Audible and Visual Notification Appliances: One of each type installed.
  7. Fuses: Two of each type installed in the system.
- 1.10 QUALITY ASSURANCE**
- A. Installer Qualifications: Personnel shall be trained and certified by manufacturer for installation of units required for this Project.
- B. Installer Qualifications: Installation shall be by personnel certified by NICET as fire-alarm Level II technician.
- C. Source Limitations for Fire-Alarm System and Components: Obtain fire-alarm system from single source from single manufacturer. Components shall be compatible with, and operate as, an extension of existing system.
- D. Electrical Components, Devices, and Accessories: Listed and labeled as defined in NFPA 70, by a qualified testing agency, and marked for intended location and application.
- E. NFPA Certification: Obtain certification according to NFPA 72 by an NRTL.
- F. NFPA Certification: Obtain certification according to NFPA 72 by a UL-listed alarm company.
- G. NFPA Certification: Obtain certification according to NFPA 72 in the form of a placard by an FMG-approved alarm company.
- H. NFPA Certification: Obtain certification according to NFPA 72 by the Authority Having Jurisdiction.
- 1.11 PROJECT CONDITIONS**
- A. Interruption of Existing Fire-Alarm Service: Do not interrupt fire-alarm service to facilities occupied by Owner or others unless permitted under the following conditions and then only after arranging to provide temporary guard service according to requirements indicated:
1. Notify Construction Manager no fewer than 7 days in advance of proposed interruption of fire-alarm service.
  2. Do not proceed with interruption of fire-alarm service without Construction Manager's written permission.
- 1.12 SEQUENCING AND SCHEDULING**
- A. Existing Fire-Alarm Equipment: Maintain existing equipment fully operational until new equipment has been tested and accepted. As new equipment is installed, label it "NOT IN SERVICE" until it is accepted. Remove labels from new equipment when put into service and label existing fire-alarm equipment "NOT IN SERVICE" until removed from the building.

- B. Equipment Removal: After acceptance of new fire-alarm system, remove existing disconnected fire-alarm equipment and wiring.

### **1.13 SOFTWARE SERVICE AGREEMENT**

- A. Comply with UL 864.
- B. Technical Support: Beginning with Substantial Completion, provide software support for two years.
- C. Upgrade Service: Update software to latest version at Project completion. Install and program software upgrades that become available within two years from date of Substantial Completion. Upgrading software shall include operating system. Upgrade shall include new or revised licenses for use of software.
  1. Provide 30 days' notice to Owner to allow scheduling and access to system and to allow Owner to upgrade computer equipment if necessary.

## **PART 2 - PRODUCTS**

### **2.1 MANUFACTURERS**

- A. Subject to compliance with requirements, provide product by the following:
  1. Simens (Match Existing)

### **2.2 SYSTEMS OPERATIONAL DESCRIPTION**

- A. Fire-alarm signal initiation shall be by one or more of the following devices[ and systems]:
  1. Manual stations.
  2. Smoke detectors.
  3. Duct smoke detectors.
  4. Verified automatic alarm operation of smoke detectors.
  5. Automatic sprinkler system water flow.
  6. Heat detectors in elevator shaft and pit.
  7. Fire-extinguishing system operation.
  8. Fire standpipe system.
- B. Fire-alarm signal shall initiate the following actions:
  1. In the Clinic and Central Utility Plant (CUP), continuously operate alarm notification appliances.
  2. In the hospital, continuously operate chime/strobe appliances in smoke zone where alarm is initiated. Continuously operate strobe appliances throughout the hospital
  3. Identify alarm at fire-alarm control unit and remote annunciators.
  4. Transmit an alarm signal to the remote alarm receiving station.
  5. Unlock electric door locks in designated egress paths.
  6. Release fire and smoke doors held open by magnetic door holders.
  7. Activate voice/alarm communication system.
  8. Switch heating, ventilating, and air-conditioning equipment controls to fire-alarm mode.
  9. Activate smoke-control system (smoke management) at firefighter smoke-control system panel.
  10. Activate stairwell and elevator-shaft pressurization systems.
  11. Close smoke dampers in air ducts of designated air-conditioning duct systems.
  12. Recall elevators to primary or alternate recall floors.
  13. Activate emergency lighting control.
  14. Activate emergency shutoffs for gas and fuel supplies.
  15. Record events in the system memory.
  16. Record events by the system printer.
- C. Supervisory signal initiation shall be by one or more of the following devices and actions:
  1. Valve supervisory switch.
  2. Low-air-pressure switch of a dry-pipe sprinkler system.
  3. Elevator shunt-trip supervision.

- D. System trouble signal initiation shall be by one or more of the following devices and actions:
1. Open circuits, shorts, and grounds in designated circuits.
  2. Opening, tampering with, or removing alarm-initiating and supervisory signal-initiating devices.
  3. Loss of primary power at fire-alarm control unit.
  4. Ground or a single break in fire-alarm control unit internal circuits.
  5. Abnormal ac voltage at fire-alarm control unit.
  6. Break in standby battery circuitry.
  7. Failure of battery charging.
  8. Abnormal position of any switch at fire-alarm control unit or annunciator.
  9. Fire-pump power failure, including a dead-phase or phase-reversal condition.
  10. Low-air-pressure switch operation on a dry-pipe or preaction sprinkler system.
- E. System Trouble and Supervisory Signal Actions: Initiate notification appliance and annunciate at fire-alarm control unit and remote annunciators. Record the event on system printer.

### **2.3 FIRE-ALARM CONTROL UNIT**

- A. General Requirements for Fire-Alarm Control Unit:
1. Field-programmable, microprocessor-based, modular, power-limited design with electronic modules, complying with UL 864 and listed and labeled by an NRTL.
    - a. System software and programs shall be held in flash electrically erasable programmable read-only memory (EEPROM), retaining the information through failure of primary and secondary power supplies.
    - b. Include a real-time clock for time annotation of events on the event recorder
    - c. Must be able to operate and monitor Pre-action systems throughout hospital
  2. Addressable initiation devices that communicate device identity and status.
    - a. Smoke sensors shall additionally communicate sensitivity setting and allow for adjustment of sensitivity at fire-alarm control unit.
    - b. Temperature sensors shall additionally test for and communicate the sensitivity range of the device.
  3. Addressable control circuits for operation of mechanical equipment.
- B. Alphanumeric Display and System Controls: Arranged for interface between human operator at fire-alarm control unit and addressable system components including annunciation and supervision. Display alarm, supervisory, and component status messages and the programming and control menu.
1. Annunciator and Display: Liquid-crystal type, 3 line(s) of 80 characters, minimum.
  2. Keypad: Arranged to permit entry and execution of programming, display, and control commands and to indicate control commands to be entered into the system for control of smoke-detector sensitivity and other parameters.
- C. Circuits:
1. Initiating Device, Notification Appliance, and Signaling Line Circuits: NFPA 72, Class A.
    - a. Initiating Device Circuits: Style D.
    - b. Notification Appliance Circuits: Style Z.
    - c. Signaling Line Circuits: Style 7.
    - d. Install no more than 50 addressable devices on each signaling line circuit.
  2. Serial Interfaces: Two RS-232 ports for printers.
- D. Stairwell Pressurization: Provide an output signal using an addressable relay to start the stairwell pressurization system. Signal shall remain on until alarm conditions are cleared and fire-alarm system is reset. Signal shall not stop in response to alarm acknowledge or signal silence commands.

1. Pressurization starts when any alarm is received at fire-alarm control unit.
  2. Alarm signals from smoke detectors at pressurization air supplies have a higher priority than other alarm signals that start the system.
- E. Smoke-Alarm Verification:
1. Initiate audible and visible indication of an "alarm-verification" signal at fire-alarm control unit.
  2. Activate an NRTL-listed and -approved "alarm-verification" sequence at fire-alarm control unit and detector.
  3. Record events by the system printer.
  4. Sound general alarm if the alarm is verified.
  5. Cancel fire-alarm control unit indication and system reset if the alarm is not verified.
- F. Notification Appliance Circuit: Operation shall sound in a temporal.
- G. Elevator Recall:
1. Smoke detectors at the following locations shall initiate automatic elevator recall. Alarm-initiating devices, except those listed, shall not start elevator recall.
    - a. Elevator lobby detectors except the lobby detector on the designated floor.
    - b. Smoke detector in elevator machine room.
    - c. Smoke detectors in elevator hoistway.
  2. Elevator lobby detectors located on the designated recall floors shall be programmed to move the cars to the alternate recall floor.
  3. Water-flow alarm connected to sprinkler in an elevator shaft and elevator machine room shall shut down elevators associated with the location without time delay.
    - a. Water-flow switch associated with the sprinkler in the elevator pit may have a delay to allow elevators to move to the designated floor.
1. Door Controls: Door hold-open devices that are controlled by smoke detectors at doors in smoke barrier walls shall be connected to fire-alarm system. Review Door Hardware Schedule for sequence of operation requiring an interface with the fire alarm system, such as release upon fire alarm. Provide all fire alarm system components to accomplish the specified sequence of operation which may require components beyond those that are indicated on drawings. Provide fire alarm release at all delayed egress doors and any other doors in the path of egress that are allowed to be locked.
- H.
- I. Remote Smoke-Detector Sensitivity Adjustment: Controls shall select specific addressable smoke detectors for adjustment, display their current status and sensitivity settings, and change those settings. Allow controls to be used to program repetitive, time-scheduled, and automated changes in sensitivity of specific detector groups. Record sensitivity adjustments and sensitivity-adjustment schedule changes in system memory, and print out the final adjusted values on system printer.
- J. Transmission to Remote Alarm Receiving Station: Automatically transmit alarm, supervisory, and trouble signals to a remote alarm station.
- K. Printout of Events: On receipt of signal, print alarm, supervisory, and trouble events. Identify zone, device, and function. Include type of signal (alarm, supervisory, or trouble) and date and time of occurrence. Differentiate alarm signals from all other printed indications. Also print system reset event, including same information for device, location, date, and time. Commands initiate the printing of a list of existing alarm, supervisory, and trouble conditions in the system and a historical log of events.
- L. Primary Power: 24-V dc obtained from 120-V ac service and a power-supply module. Initiating devices, notification appliances, signaling lines, trouble signals, supervisory and digital alarm communicator transmitters shall be powered by 24-V dc source.
1. Alarm current draw of entire fire-alarm system shall not exceed 80 percent of the power-supply module rating.

- M. Secondary Power: 24-V dc supply system with batteries, automatic battery charger, and automatic transfer switch.
  - 1. Batteries: Sealed, valve-regulated, recombinant lead acid.
- N. Instructions: Computer printout or typewritten instruction card mounted behind a plastic or glass cover in a stainless-steel or aluminum frame. Include interpretation and describe appropriate response for displays and signals. Briefly describe the functional operation of the system under normal, alarm, and trouble conditions.

## 2.4 MANUAL FIRE-ALARM BOXES

- A. General Requirements for Manual Fire-Alarm Boxes: Comply with UL 38. Boxes shall be finished in red with molded, raised-letter operating instructions in contrasting color; shall show visible indication of operation; and shall be mounted on recessed outlet box. If indicated as surface mounted, provide manufacturer's surface back box.
  - 1. Double-action mechanism requiring two actions to initiate an alarm, pull-lever type; with integral addressable module arranged to communicate manual-station status (normal, alarm, or trouble) to fire-alarm control unit.
  - 2. Station Reset: Key- or wrench-operated switch.
  - 3. Indoor Protective Shield: Factory-fabricated clear plastic enclosure hinged at the top to permit lifting for access to initiate an alarm. Lifting the cover actuates an integral battery-powered audible horn intended to discourage false-alarm operation.
  - 4. Weatherproof Protective Shield: Factory-fabricated clear plastic enclosure hinged at the top to permit lifting for access to initiate an alarm.

## 2.5 SYSTEM SMOKE DETECTORS

- A. General Requirements for System Smoke Detectors:
  - 1. Comply with UL 268; operating at 24-V dc, nominal.
  - 2. Detectors shall be four-wire type.
  - 3. Integral Addressable Module: Arranged to communicate detector status (normal, alarm, or trouble) to fire-alarm control unit.
  - 4. Base Mounting: Detector and associated electronic components shall be mounted in a twist-lock module that connects to a fixed base. Provide terminals in the fixed base for connection to building wiring.
  - 5. Self-Restoring: Detectors do not require resetting or readjustment after actuation to restore them to normal operation.
  - 6. Integral Visual-Indicating Light: LED type indicating detector has operated and power-on status.
  - 7. Remote Control: Unless otherwise indicated, detectors shall be analog-addressable type, individually monitored at fire-alarm control unit for calibration, sensitivity, and alarm condition and individually adjustable for sensitivity by fire-alarm control unit.
    - a. Rate-of-rise temperature characteristic shall be selectable at fire-alarm control unit for 15 or 20 deg F (8 or 11 deg C) per minute.
    - b. Fixed-temperature sensing shall be independent of rate-of-rise sensing and shall be settable at fire-alarm control unit to operate at 135 or 155 deg F (57 or 68 deg C).
    - c. Provide multiple levels of detection sensitivity for each sensor.
- B. Photoelectric Smoke Detectors:
  - 1. Detector address shall be accessible from fire-alarm control unit and shall be able to identify the detector's location within the system and its sensitivity setting.
  - 2. An operator at fire-alarm control unit, having the designated access level, shall be able to manually access the following for each detector:
    - a. Primary status.
    - b. Device type.
    - c. Present average value.
    - d. Present sensitivity selected.
    - e. Sensor range (normal, dirty, etc.).

- C. Ionization Smoke Detector:
1. Detector address shall be accessible from fire-alarm control unit and shall be able to identify the detector's location within the system and its sensitivity setting.
  2. An operator at fire-alarm control unit, having the designated access level, shall be able to manually access the following for each detector:
    - a. Primary status.
    - b. Device type.
    - c. Present average value.
    - d. Present sensitivity selected.
    - e. Sensor range (normal, dirty, etc.).
- D. Duct Smoke Detectors: Photoelectric type complying with UL 268A.
1. Detector address shall be accessible from fire-alarm control unit and shall be able to identify the detector's location within the system and its sensitivity setting.
  2. An operator at fire-alarm control unit, having the designated access level, shall be able to manually access the following for each detector:
    - a. Primary status.
    - b. Device type.
    - c. Present average value.
    - d. Present sensitivity selected.
    - e. Sensor range (normal, dirty, etc.).
  3. Weatherproof Duct Housing Enclosure: NEMA 250, Type 4X; NRTL listed for use with the supplied detector.
  4. Each sensor shall have multiple levels of detection sensitivity.
  5. Sampling Tubes: Design and dimensions as recommended by manufacturer for specific duct size, air velocity, and installation conditions where applied.
  6. Relay Fan Shutdown: Rated to interrupt fan motor-control circuit.
  7. Remote Test Station (RTS): Provide keyed type RTS. Comply with NFPA 72, owner, AHJ, architect, and EOR locations.

## 2.6 HEAT DETECTORS

- A. General Requirements for Heat Detectors: Comply with UL 521.
- B. Heat Detector, Combination Type: Actuated by either a fixed temperature of **135 deg F (57 deg C)** or a rate of rise that exceeds **15 deg F (8 deg C)** per minute unless otherwise indicated.
1. Mounting: Twist-lock base interchangeable with smoke-detector bases.
  2. Integral Addressable Module: Arranged to communicate detector status (normal, alarm, or trouble) to fire-alarm control unit.

## 2.7 NOTIFICATION APPLIANCES

- A. General Requirements for Notification Appliances: Individually addressed, connected to a signaling line circuit, equipped for mounting as indicated and with screw terminals for system connections.
- B. General Requirements for Notification Appliances: Connected to notification appliance signal circuits, zoned as indicated, equipped for mounting as indicated and with screw terminals for system connections.
1. Combination Devices: Factory-integrated audible and visible devices in a single-mounting assembly, equipped for mounting as indicated and with screw terminals for system connections.
- C. Chimes, Low-Level Output: Vibrating type, 75-dBA minimum rated output.
- D. Chimes, High-Level Output: Vibrating type, 81-dBA minimum rated output.
- E. Horns: Electric-vibrating-polarized type, 24-V dc; with provision for housing the operating mechanism behind a grille. Comply with UL 464. Horns shall produce a sound-pressure level of 90 dBA, measured **10 feet (3 m)** from the horn, using the coded signal prescribed in UL 464 test protocol.

- F. Visible Notification Appliances: Xenon strobe lights comply with UL 1971, with clear or nominal white polycarbonate lens mounted on an aluminum faceplate. The word "FIRE" is engraved in minimum **1-inch- (25-mm-)** high letters on the lens.
1. Rated Light Output:
    - a. 15/30/75/110 cd, selectable in the field.
  2. Mounting: Wall mounted unless otherwise indicated.
  3. For units with guards to prevent physical damage, light output ratings shall be determined with guards in place.
  4. Flashing shall be in a temporal pattern, synchronized with other units.
  5. Strobe Leads: Factory connected to screw terminals.
  6. Mounting Faceplate: Factory finished, white.

## **2.8 MAGNETIC DOOR HOLDERS**

- A. Description: Units are equipped for wall or floor mounting as indicated and are complete with matching doorplate.
1. Electromagnet: Requires no more than 3 W to develop **25-lbf (111-N)** holding force.
  2. Wall-Mounted Units: Flush mounted unless otherwise indicated.
  3. Rating: 24-V ac or dc.
  4. Rating: 120-V ac.
- B. Material and Finish: Match door hardware.

## **2.9 REMOTE ANNUNCIATOR**

- A. Description: Annunciator functions shall match those of fire-alarm control unit for alarm, supervisory, and trouble indications. Manual switching functions shall match those of fire-alarm control unit, including acknowledging, silencing, resetting, and testing.
1. Mounting: Flush cabinet, NEMA 250, Type 1.
- B. Display Type and Functional Performance: Alphanumeric display and LED indicating lights shall match those of fire-alarm control unit. Provide controls to acknowledge, silence, reset, and test functions for alarm, supervisory, and trouble signals.

## **2.10 ADDRESSABLE INTERFACE DEVICE**

- A. Description: Microelectronic monitor module, NRTL listed for use in providing a system address for alarm-initiating devices for wired applications with normally open contacts.
- B. Integral Relay: Capable of providing a direct signal to elevator controller to initiate elevator recall to circuit-breaker shunt trip for power shutdown.

## **2.11 DIGITAL ALARM COMMUNICATOR TRANSMITTER**

- A. Digital alarm communicator transmitter shall be acceptable to the remote central station and shall comply with UL 632 and be listed and labeled by an NRTL.
- B. Functional Performance: Unit shall receive an alarm, supervisory, or trouble signal from fire-alarm control unit and automatically capture two telephone line(s) and dial a preset number for a remote central station. When contact is made with central station(s), signals shall be transmitted. If service on either line is interrupted for longer than 45 seconds, transmitter shall initiate a local trouble signal and transmit the signal indicating loss of telephone line to the remote alarm receiving station over the remaining line. Transmitter shall automatically report telephone service restoration to the central station. If service is lost on both telephone lines, transmitter shall initiate the local trouble signal.
- C. Local functions and display at the digital alarm communicator transmitter shall include the following:
1. Verification that both telephone lines are available.
  2. Programming device.
  3. LED display.
  4. Manual test report function and manual transmission clear indication.
  5. Communications failure with the central station or fire-alarm control unit.



- D. Digital data transmission shall include the following:
    - 1. Address of the alarm-initiating device.
    - 2. Address of the supervisory signal.
    - 3. Address of the trouble-initiating device.
    - 4. Loss of ac supply or loss of power.
    - 5. Low battery.
    - 6. Abnormal test signal.
    - 7. Communication bus failure.
  - E. Secondary Power: Integral rechargeable battery and automatic charger.
  - F. Self-Test: Conducted automatically every 24 hours with report transmitted to central station.
- 2.12 SYSTEM PRINTER**
- A. Printer shall be listed and labeled by an NRTL as an integral part of fire-alarm system.
- 2.13 DEVICE GUARDS**
- A. Description: Welded wire mesh of size and shape for the manual station, smoke detector, gong, or other device requiring protection.
    - 1. Factory fabricated and furnished by manufacturer of device.
    - 2. Finish: Paint of color to match the protected device.

### **PART 3 - EXECUTION**

#### **3.1 EQUIPMENT INSTALLATION**

- A. Comply with NFPA 72 for installation of fire-alarm equipment.
- B. Install wall-mounted equipment, with tops of cabinets not more than **72 inches (1830 mm)** above the finished floor.
  - 1. Comply with requirements for seismic-restraint devices specified in Section 260548 "Vibration and Seismic Controls for Electrical Systems."
- C. Smoke- or Heat-Detector Spacing:
  - 1. Comply with NFPA 72, "Smoke-Sensing Fire Detectors" Section in the "Initiating Devices" Chapter, for smoke-detector spacing.
  - 2. Comply with NFPA 72, "Heat-Sensing Fire Detectors" Section in the "Initiating Devices" Chapter, for heat-detector spacing.
  - 3. Smooth ceiling spacing shall not exceed **30 feet (9 m)**.
  - 4. HVAC: Locate detectors not closer than **3 feet (1 m)** from air-supply diffuser or return-air opening.
  - 5. Lighting Fixtures: Locate detectors not closer than **12 inches (300 mm)** from any part of a lighting fixture.
- D. Duct Smoke Detectors: Comply with NFPA 72 and NFPA 90A. Install sampling tubes so they extend the full width of duct. Install keyed remote test stations in acceptable locations.
- E. Heat Detectors in Elevator Shafts: Coordinate temperature rating and location with sprinkler rating and location.
- F. Single-Station Smoke Detectors: Where more than one smoke alarm is installed within a dwelling or suite, they shall be connected so that the operation of any smoke alarm causes the alarm in all smoke alarms to sound.
- G. Remote Status and Alarm Indicators: Install near each smoke detector and each sprinkler water-flow switch and valve-tamper switch that is not readily visible from normal viewing position.
- H. Remote Test Station (RTS): Install keyed test station in wall near each duct smoke detector that is not readily visible from normal viewing position. Provide in locations acceptable to owner, AHJ, Architect, & EOR.
- I. Audible Alarm-Indicating Devices: Install not less than **6 inches (150 mm)** below the ceiling. Install bells and horns on flush-mounted back boxes with the device-operating mechanism concealed behind a grille.

- J. Visible Alarm-Indicating Devices: Install adjacent to each alarm bell or alarm horn and at least **6 inches (150 mm)** below the ceiling.
- K. Device Location-Indicating Lights: Locate in public space near the device they monitor.
- L. Fire-Alarm Control Unit: Surface mounted, with tops of cabinets not more than **72 inches (1830 mm)** above the finished floor.
- M. Annunciator: Install with top of panel not more than **72 inches (1830 mm)** above the finished floor.

### **3.2 WIRING INSTALLATION**

- A. Wiring Method: Install wiring in metal raceway according to Division 26 Section 260519 Conceal raceway except in unfinished spaces and as indicated.
- B. Wiring for Grid Ceiling Mounted Devices: Install junction box at accessible location above ceiling. Use flexible metal conduit for wiring between junction box and outlet box for ceiling mounted device. Secure flexible conduit within 12 inches of junction box.
- C. Wiring within Enclosures: Separate power-limited and non-power-limited conductors as recommended by the manufacturer. Install conductors parallel with or at right angles to sides and back of the enclosure. Bundle, lace, and train conductors to terminal points with no excess. Connect conductors that are terminated, spliced, or interrupted in any enclosure associated with the fire alarm system to terminal blocks. Mark each terminal according to the system's wiring diagrams. Make all connections with approved crimp-on terminal spade lugs, pressure-type terminal blocks, or plug connectors.
- D. Cable Taps: Use numbered terminal strips in junction, pull and outlet boxes, cabinets, or equipment enclosures where circuit connections are made.
- E. Color-Coding: Color-code fire alarm conductors differently from the normal building power wiring. Use one color-code for alarm circuit wiring and a different color-code for supervisory circuits. Color-code audible alarm-indicating circuits differently from alarm-initiating circuits. Use different colors for visible alarm-indicating devices. Paint fire alarm system junction boxes and covers red.
- F. Risers: Install at least two vertical cable risers to serve the fire alarm system. Separate risers in close proximity to each other with a minimum one-hour-rated wall, so the loss of one riser does not prevent the receipt or transmission of signal from other floors or zones.
- G. Wiring to Remote Alarm Transmitting Device: **1-inch (25-mm)** conduit between the FACP and the transmitter. Install number of conductors and electrical supervision for connecting wiring as needed to suit monitoring function.

### **3.3 CONNECTIONS**

- A. For fire-protection systems related to doors in fire-rated walls and partitions and to doors in smoke partitions, comply with requirements in Section 087100 "Door Hardware." Connect hardware and devices to fire-alarm system.
  - 1. Verify that hardware and devices are NRTL listed for use with fire-alarm system in this Section before making connections.

- B. Make addressable connections with a supervised interface device to the following devices and systems. Install the interface device less than **3 feet (1 m)** from the device controlled. Make an addressable confirmation connection when such feedback is available at the device or system being controlled.
1. Alarm-initiating connection to smoke-control system (smoke management) at firefighter smoke-control system panel.
  2. Alarm-initiating connection to stairwell and elevator-shaft pressurization systems.
  3. Smoke dampers in air ducts of designated air-conditioning duct systems. Provide end switches at each smoke and fire/smoke damper
  4. Alarm-initiating connection to elevator recall system and components.
  5. Alarm-initiating connection to activate emergency lighting control.
  6. Alarm-initiating connection to activate emergency shutoffs for gas and fuel supplies.
  7. Supervisory connections at valve supervisory switches.
  8. Supervisory connections at low-air-pressure switch of each dry-pipe sprinkler system.
  9. Supervisory connections at elevator shunt trip breaker.
  10. Supervisory connections at fire-pump power failure including a dead-phase or phase-reversal condition.
  11. Supervisory connections at fire-pump engine control panel.

### **3.4 IDENTIFICATION**

- A. Identify system components, wiring, cabling, and terminals. Comply with requirements for identification specified in Section 260553 "Identification for Electrical Systems."
- B. Install framed instructions in a location visible from fire-alarm control unit.

### **3.5 GROUNDING**

- A. Ground fire-alarm control unit and associated circuits; comply with IEEE 1100. Install a ground wire from main service ground to fire-alarm control unit.

### **3.6 FIELD QUALITY CONTROL**

- A. Field tests shall be witnessed by authorities having jurisdiction.
- B. Manufacturer's Field Service: Engage a factory-authorized service representative to inspect, test, and adjust components, assemblies, and equipment installations, including connections.
- C. Perform tests and inspections.
1. Manufacturer's Field Service: Engage a factory-authorized service representative to inspect components, assemblies, and equipment installations, including connections, and to assist in testing.
- D. Tests and Inspections:
1. Visual Inspection: Conduct visual inspection prior to testing.
    - a. Inspection shall be based on completed Record Drawings and system documentation that is required by NFPA 72 in its "Completion Documents, Preparation" Table in the "Documentation" Section of the "Fundamentals of Fire Alarm Systems" Chapter.
    - b. Comply with "Visual Inspection Frequencies" Table in the "Inspection" Section of the "Inspection, Testing and Maintenance" Chapter in NFPA 72; retain the "Initial/Reacceptance" column and list only the installed components.
  2. System Testing: Comply with "Test Methods" Table in the "Testing" Section of the "Inspection, Testing and Maintenance" Chapter in NFPA 72.
  3. Test audible appliances for the public operating mode according to manufacturer's written instructions. Perform the test using a portable sound-level meter complying with Type 2 requirements in ANSI S1.4.
  4. Test audible appliances for the private operating mode according to manufacturer's written instructions.
  5. Test visible appliances for the public operating mode according to manufacturer's written instructions.

6. Factory-authorized service representative shall prepare the "Fire Alarm System Record of Completion" in the "Documentation" Section of the "Fundamentals of Fire Alarm Systems" Chapter in NFPA 72 and the "Inspection and Testing Form" in the "Records" Section of the "Inspection, Testing and Maintenance" Chapter in NFPA 72.
  - E. Reacceptance Testing: Perform reacceptance testing to verify the proper operation of added or replaced devices and appliances.
  - F. Fire-alarm system will be considered defective if it does not pass tests and inspections.
  - G. Prepare test and inspection reports.
  - H. Maintenance Test and Inspection: Perform tests and inspections listed for weekly, monthly, quarterly, and semiannual periods. Use forms developed for initial tests and inspections.
  - I. Annual Test and Inspection: One year after date of Substantial Completion, test fire-alarm system complying with visual and testing inspection requirements in NFPA 72. Use forms developed for initial tests and inspections.
- 3.7 DEMONSTRATION**
- A. Engage a factory-authorized service representative to train Owner's maintenance personnel to adjust, operate, and maintain fire-alarm system.

**END OF SECTION**

