

# BIG LOTS!

## New Canopy

3801 Washington Blvd.  
Ogden, Utah 84403

Case, Lowe and Hart, Inc.  
2484 Washington Blvd. Ste 510  
Ogden, Utah 84401

ARW Engineers  
1594 W. Park Cir.  
Ogden, Utah 84404

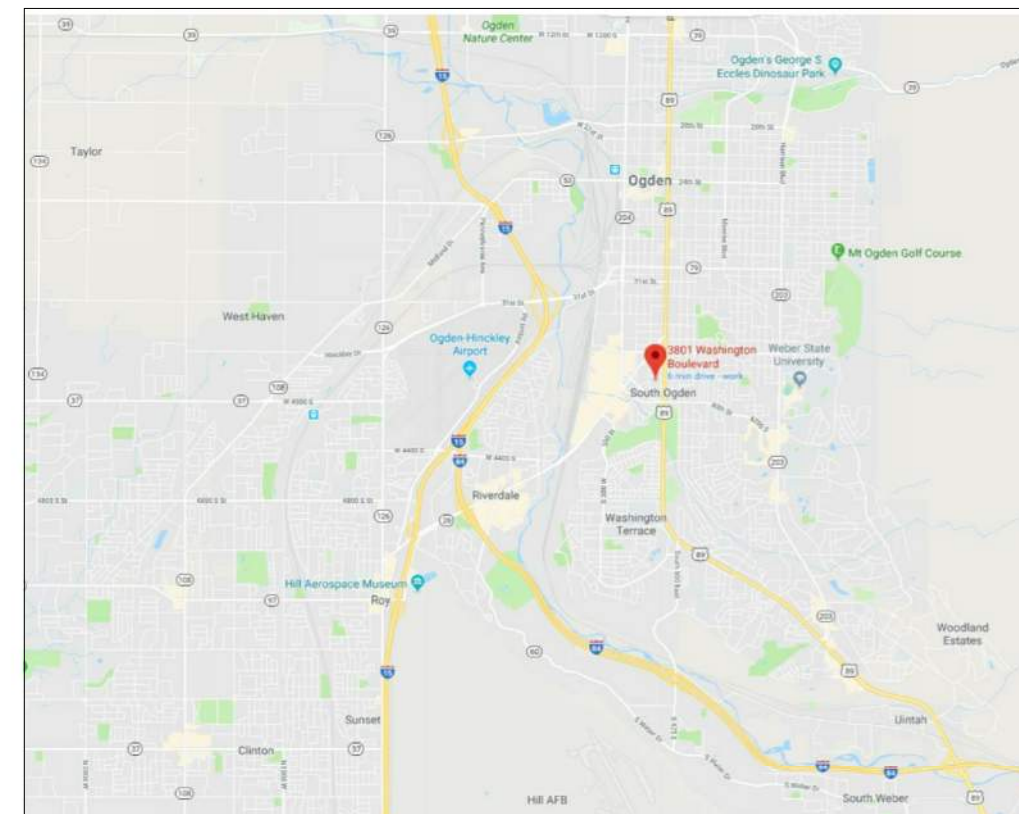

VICINITY MAP

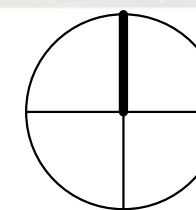

### DRAWING INDEX

G001	TITLE SHEET	
AD101	ARCHITECTURAL DEMO PLAN AND ELEVATION	
ED101	ELECTRICAL DEMOLITION PLAN	
S001	STRUCTURAL NOTES	
S002	STRUCTURAL NOTES	
S003	SCHEDULES	
S004	SCHEDULES	
S005	SCHEDULES	
S101	FOOTING AND FOUNDATION PLAN	
S201	DETAILS	
S202	DETAILS	
A001	ARCHITECTURAL NOTES	
A101	FLOOR PLAN	
A201	EXTERIOR ELEVATIONS	
A301	SECTIONS	
A501	DETAILS	
A801	3D VIEW	
E001	ELECTRICAL LEGEND	
EL101	ELECTRICAL LIGHTING PLAN	

### CODE INFORMATION

DESCRIPTION- EXISTING TYPE V6 BUILDING AND M OCCUPANCY. REMOVE EXISTING WOOD CANOPY, ROOF, SOFFIT, LIGHTS. REPLACE WITH NEW STEEL STRUCTURE, METAL STUD FASCIA, LIGHTS AND ROOFING.

APPLICABLE CODES- 2015 IBC, 2015 IEBC, 2014 NEC  
 OCCUPANCY- M  
 BUILDING TYPE- V6  
 FIRE SUPPRESSION SYSTEM- YES  
 ALLOWABLE AREA- EXISTING BUILDING  
 FIRE WALLS- EXISTING  
 PLUMBING REQUIRES- EXISTING

### DEFERRED SUBMITTALS

- 1-FIRE SUPPRESSION SYSTEM TO BE DESIGNED AND DETAILED BY GC AND SUB CONTRACTOR. PROVIDE TO CITY FOR APPROVAL.
- 2- PROVIDE METAL STUD DESIGN, CONNECTIONS AND ETC FOR ALL METAL STUD WALLS AND SOFFIT.

IF SHEET IS LESS THAN 22"x 34"  
IT IS A REDUCED PRINT.  
REDUCE SCALE ACCORDINGLY

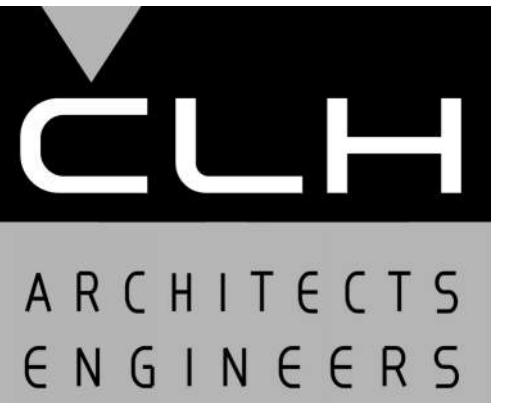

Case, Lowe & Hart, Inc. • 2484 Washington Blvd.  
Suite 510 • Ogden, Utah • 84401  
801.399.5821 • www.clhae.com

### CONSULTANTS

### STAMP



## New Canopy

3801 Washington Blvd.  
South Ogden, Utah

MARK	DATE	DESCRIPTION

ISSUE DATE: 10/24/2019  
 PROJECT NO: 19060  
 CAD DWG FILE:  
 DRAWN BY: KDL  
 CHK'D BY: SIP

REVIEW SET  
24 OCT 2019

### SHEET TITLE

TITLE SHEET

### SHEET NO:

G001



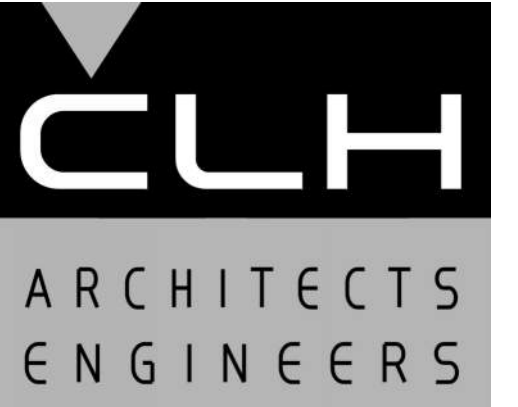

Case, Lowe & Hart, Inc. • 2484 Washington Blvd.  
Suite 510 • Ogden, Utah • 84401  
801.399.5821 • www.clhae.com

CONSULTANTS

STAMP

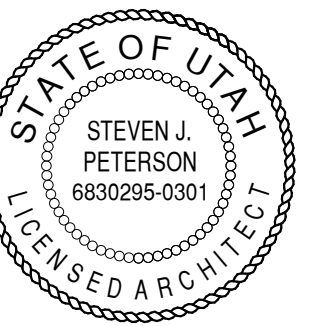

New Canopy

3801 Washington Blvd.  
South Ogden, Utah

MARK	DATE	DESCRIPTION

ISSUE DATE:	10/24/2019
PROJECT NO:	19060
CAD DWG FILE:	
DRAWN BY:	KDL
CHK'D BY:	SIP

REVIEW SET  
24 OCT 2019

SHEET TITLE

ARCHITECTURAL  
DEMO PLAN AND  
ELEVATION

SHEET NO:

AD101

**DEMOLITION KEYED NOTES**

MARK	NOTE
AD01	REMOVE (E) BEAMS AND TRIM.
AD02	REMOVE (E) WOOD SIDING AND TRIM
AD03	REMOVE (E) WALL AND SIDING
AD04	REMOVE (E) ROOFING, DECK AND STRUCTURE
AD05	REMOVE (E) ROOFING, GRAVEL STOP AND WALL REGLET
AD06	CUT AND REMOVE (E) ANGLE BRACES
AD07	REMOVE (E) BRICK VENEER- GRIND COL SMOOTH AND PAINT. GRIND CONC SLAB SMOOTH AND REFINISH TO MATCH ADJACENT SURFACE.
AD08	SAWCUT AND REMOVE EXISTING CONC. SLAB AND REMOVE EARTH AS REQUIRED FOR NEW FOOTINGS- SEE STRUCTURAL. POUR SLAB BACK TO MATCH ADJACENT SURFACE AND FINISH.

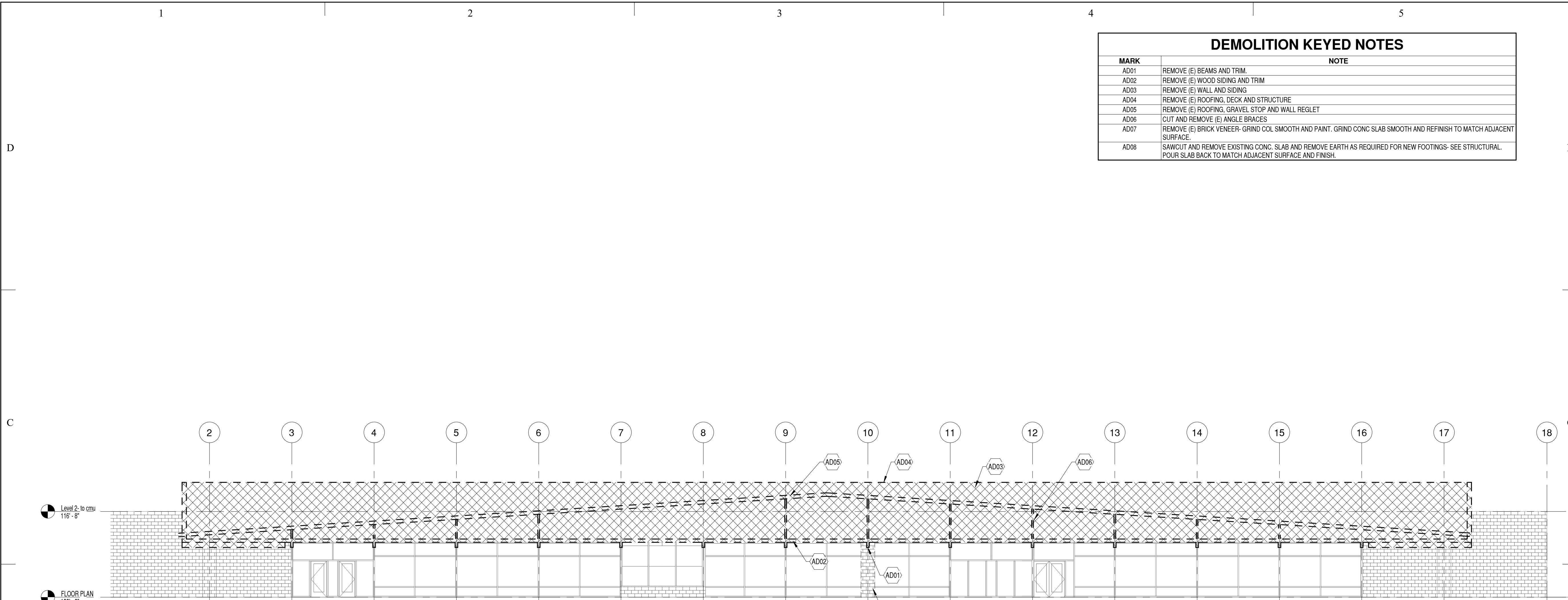

**C1 EAST DEMOLITION ELEVATION**

3/32" = 1'-0"

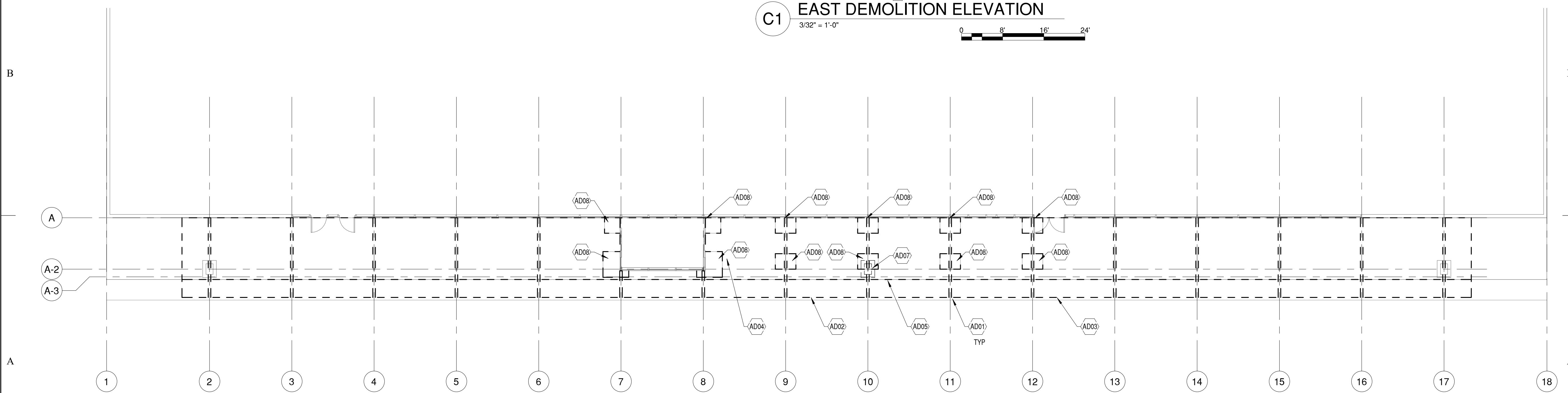

**A1 MAIN FLOOR DEMOLITION PLAN**

3/32" = 1'-0"

IF SHEET IS LESS THAN 22"x 34"  
IT IS A REDUCED PRINT.  
REDUCE SCALE ACCORDINGLY

10/24/2019 9:56:27 AM

ELECTRICAL DEMOLITION KEYED NOTES	
MARK	NOTE
ED1	REMOVE & STORE EXISTING LIGHT FIXTURE FOR RE-INSTALLATION.
ED2	REMOVE EXISTING LIGHT FIXTURE.
ED3	EXISTING TO REMAIN.
ED4	DISCONNECT SIGN & MAINTAIN CIRCUITS TO RE-CONNECT SIGN IN NEW LOCATION.

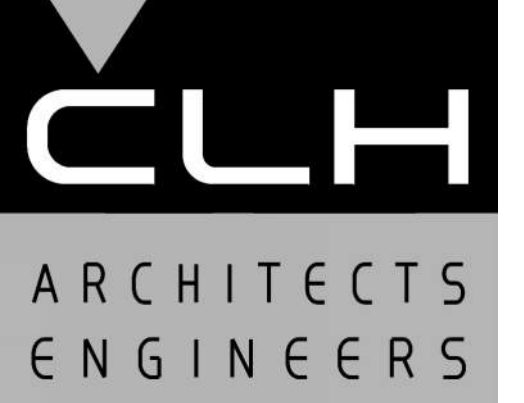

Case, Lowe & Hart, Inc. • 2484 Washington Blvd.  
Suite 510 • Ogden, Utah • 84401  
801.399.5821 • www.clhac.com

CONSULTANTS

STAMP

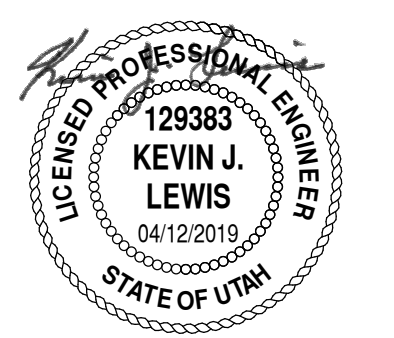

New Canopy  
3801 Washington Blvd.  
South Ogden, Utah

MARK	DATE	DESCRIPTION

ISSUE DATE:	10/24/2019
PROJECT NO:	19060
CAD DWG FILE:	
DRAWN BY:	J.M.S.
CHK'D BY:	K.J.L.

REVIEW SET
24 OCT 2019

SHEET TITLE  
**ELECTRICAL DEMOLITION PLAN**

SHEET NO:  
**ED101**

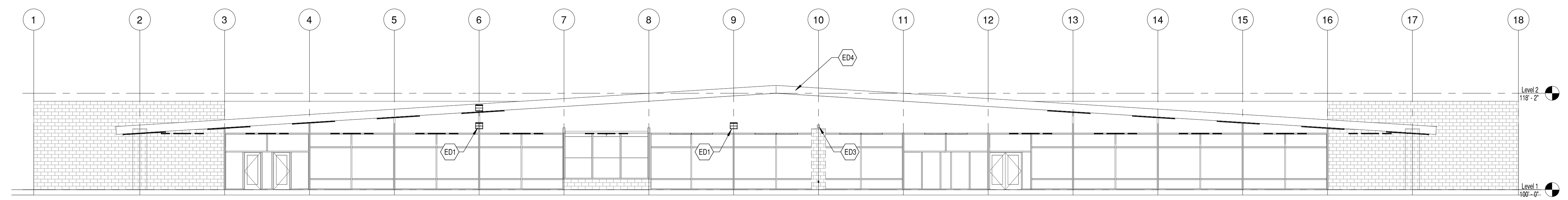

**C1 FRONT ELEVATION DEMOLITION**  
3/32" = 1'-0"  
0 8' 16' 24'

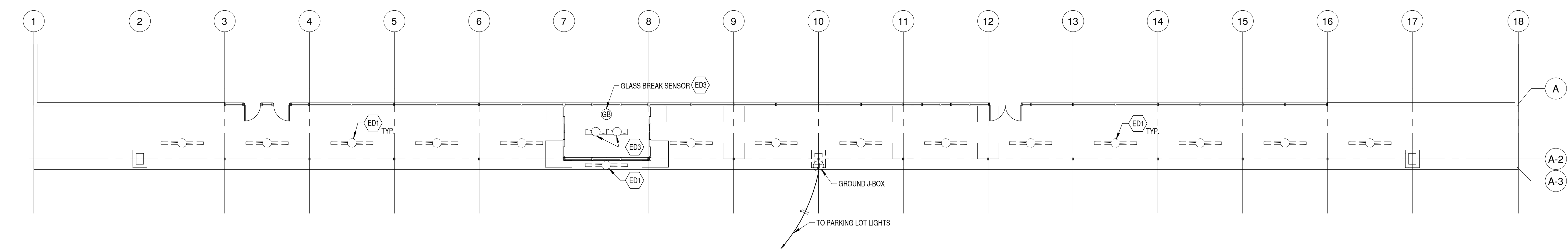

**B1 ELECTRICAL DEMOLITION PLAN**  
3/32" = 1'-0"  
0 8' 16' 24'

IF SHEET IS LESS THAN 22"x 34"  
IT IS A REDUCED PRINT.  
REDUCE SCALE ACCORDINGLY

10/24/2019 9:59:09 AM



**STRUCTURAL NOTES :**

**A. GENERAL**

1. THE STRUCTURAL NOTES ARE INTENDED TO COMPLEMENT THE PROJECT SPECIFICATIONS WHICH ARE PART OF THE CONSTRUCTION DOCUMENTS. SPECIFIC NOTES AND DETAILS ON THE DRAWINGS SHALL GOVERN OVER THE STRUCTURAL NOTES AND TYPICAL DETAILS.
2. THESE DRAWINGS (AND, WHERE APPLICABLE, ACCOMPANYING WRITTEN SPECIFICATIONS) ARE THE ONLY CONTRACT DOCUMENTS PROVIDED BY ARW ENGINEERS FOR THE PROJECT REPRESENTED HEREIN. NOTHING IN ANY DIGITAL MODEL OR DIGITAL FILE RELATED TO THIS PROJECT SHALL BE TAKEN TO SUPERSEDE ANY INFORMATION SHOWN IN THESE DRAWINGS (INCLUDING, BUT NOT LIMITED TO, DIMENSIONS, SIZES, ETC.).
3. THE ARCHITECTURAL DRAWINGS ARE THE PRIME CONTRACT DRAWINGS. THE STRUCTURAL DRAWINGS ARE SUPPLEMENTARY TO AND MUST BE USED IN CONJUNCTION WITH THE ARCHITECTURAL DRAWINGS AND OTHER CONSULTANTS DRAWINGS. ALL OMISSIONS OR CONFLICTS BETWEEN THE VARIOUS ELEMENTS OF THE WORKING DRAWINGS AND/OR SPECIFICATIONS SHALL BE BROUGHT TO THE ATTENTION OF THE ARCHITECT AND STRUCTURAL ENGINEER BEFORE PROCEEDING WITH ANY WORK INVOLVED. IN CASE OF CONFLICT, FOLLOW THE MOST STRINGENT REQUIREMENT AS DIRECTED BY THE ARCHITECT AT NO ADDITIONAL COST TO THE OWNER.
4. SEE SPECIFICATIONS FOR REQUIRED SUBMITTALS. SUBMITTALS SHALL BE MADE IN A TIMELY MANNER AS INDICATED IN SPECIFICATIONS. REVIEW OF SUBMITTALS BY ARW ENGINEERS IS FOR GENERAL COMPLIANCE ONLY AND IS NOT INTENDED AS APPROVAL. CONTRACTOR IS RESPONSIBLE FOR VERIFYING ALL SIZES, DIMENSIONS, AND ELEVATIONS ON SUBMITTALS AS RELATED TO DESIGN DOCUMENTS. PREPARATION OF SHOP DRAWINGS FOR STRUCTURAL ELEMENTS WILL REQUIRE INFORMATION (I.E. DIMENSIONS, ETC.) FOUND IN THE ARCHITECTURAL, STRUCTURAL, AND OTHER CONSULTANTS DRAWINGS.
5. THE CONTRACTOR SHALL VERIFY ALL CONDITIONS AND DIMENSIONS AT THE SITE. IF ACTUAL CONDITIONS DIFFER FROM THOSE SHOWN ON CONTRACT DOCUMENTS, CONTRACTOR SHALL NOTIFY ARCHITECT PRIOR TO FABRICATION OR CONSTRUCTION OF ANY AFFECTED ELEMENTS.
6. THE CONTRACTOR SHALL COORDINATE AND VERIFY ALL LOCATIONS AND SIZES OF MECHANICAL EQUIPMENT OR OTHER EQUIPMENT BEFORE FABRICATING AND ERECTING STRUCTURAL ELEMENTS. SIZES AND LOCATIONS THAT DIFFER FROM THOSE SHOWN ON THE CONTRACT DOCUMENTS SHALL BE REPORTED TO THE ARCHITECT.
7. THE CONTRACTOR SHALL SUBMIT A WRITTEN REQUEST TO THE ARCHITECT FOR ARCHITECT AND/OR ENGINEER APPROVAL BEFORE PROCEEDING WITH ANY CHANGES, MODIFICATIONS, OR SUBSTITUTIONS.
8. OBSERVATION VISITS TO THE SITE BY ARW ENGINEERS FIELD REPRESENTATIVES SHALL NEITHER BE CONSTRUED AS INSPECTION NOR APPROVAL OF CONSTRUCTION.
9. DURING CONSTRUCTION, BUILDERS SHALL KEEP LOADS ON STRUCTURE WITHIN THE LIMITS OF DESIGN LOADS AS NOTED IN THESE DOCUMENTS.
10. TYPICAL OR SIMILAR DETAILS AND SECTIONS SHALL APPLY WHERE SPECIFIC DETAILS ARE NOT SHOWN. TYPICAL OR SIMILAR DETAILS REFER TO THE CONDITION ADDRESSED AND ARE NOT NECESSARILY DETAILS LABELED "TYPICAL" OR "SIMILAR" IN THE PLANS AND DOCUMENTS.
11. DRAWINGS AND DETAILS HAVE BEEN PREPARED WITH THE INTENT TO VISUALLY REPRESENT INFORMATION PROVIDED IN SCALED FORM; HOWEVER CONTRACTORS/SUPPLIERS SHOULD NOT SCALE PLANS OR DETAILS FOR DIMENSIONAL INFORMATION.
12. THE CONTRACTOR SHALL PROVIDE ADEQUATE TEMPORARY SHORING AND BRACING FOR ALL STRUCTURAL ELEMENTS UNTIL THE ENTIRE STRUCTURAL SYSTEM IS COMPLETED. DESIGN OF ALL SHORING AND BRACING IS BY OTHERS AT NO ADDITIONAL COST TO THE OWNER.
13. ENGINEER SHALL NOT BE RESPONSIBLE FOR ACTIVITIES UNDER CONTROL OF THE CONTRACTOR SUCH AS CONSTRUCTION SITE SAFETY, MEANS, METHODS AND SEQUENCING OF CONSTRUCTION. ENGINEER SHALL NOT BE RESPONSIBLE FOR FABRICATION, ERECTION AND CONSTRUCTION REQUIREMENTS AS PRESCRIBED BY OSHA OR OTHER REGULATORY AGENCIES REGARDLESS OF INDICATIONS IN THESE DOCUMENTS.
14. NOTICE OF COPYRIGHT: THESE STRUCTURAL DRAWINGS ARE HEREBY COPYRIGHTED BY ARW ENGINEERS. ALL RIGHTS RESERVED. THESE DOCUMENTS DEFINE A STRUCTURE AND ARE INSTRUMENTS OF SERVICE, FOR ONE USE ONLY. REPRODUCTION AND DISTRIBUTION OF THESE DRAWINGS IS ONLY ALLOWED AS REQUIRED FOR REGULATORY AGENCIES AND FOR CONVEYANCE OF INFORMATION TO PARTIES INVOLVED IN THE CONSTRUCTION OF THIS PROJECT. THESE DOCUMENTS SHALL NOT BE REPRODUCED OR COPIED, IN PART OR WHOLE BY ANY PARTY FOR USE IN PREPARATION OF SHOP DRAWINGS OR OTHER SUBMITTALS.
15. WHERE THE WORD "SHALL" OCCURS IN THESE DRAWINGS AND ANY ACCOMPANYING SPECIFICATIONS, IT IS CONSIDERED A MANDATORY OBLIGATION AND SYNONYMOUS WITH THE PHRASE "HAS DUTY TO".

**B. STATEMENT OF SPECIAL INSPECTIONS AND SPECIAL INSPECTIONS**

1. THE DESIGNATED SEISMIC/WIND SYSTEMS AND SEISMIC/WIND-FORCE-RESISTING SYSTEMS THAT ARE SUBJECT TO SPECIAL INSPECTIONS IN ACCORDANCE WITH IBC SECTION 1705.11 AND 1705.12 ARE IDENTIFIED ON THESE DOCUMENTS WITH A CIRCLE "L". ALL OTHER ITEMS REQUIRING SPECIAL INSPECTION ARE IDENTIFIED IN THE SPECIAL INSPECTION SCHEDULE ON SHEET S004 AND S005.
2. SPECIAL INSPECTIONS AND TESTING ARE TO BE PROVIDED AS REQUIRED BY IBC SECTIONS 1704 THROUGH 1705 AND OTHER APPLICABLE SECTIONS OF THE IBC. THE TYPE AND FREQUENCY OF TESTING AND SPECIAL INSPECTIONS SHALL BE AS NOTED IN THE SPECIAL INSPECTION SCHEDULE, JOB SPECIFICATIONS, AND ACCORDANCE WITH IBC SECTION 110 AND CHAPTER 17. CONTRACTOR SHALL COORDINATE AND COOPERATE WITH REQUIRED INSPECTIONS.
3. ALL TESTING AND SPECIAL INSPECTION SHALL BE PROVIDED BY A QUALIFIED INDEPENDENT SPECIAL INSPECTION AGENCY IN ACCORDANCE WITH IBC 1704 AND AS OUTLINED IN THE JOB SPECIFICATIONS. REPORTS OF FINDINGS OR DISCREPANCIES SHALL BE NOTED AND FORWARDED TO THE CONTRACTOR, ARCHITECT, ENGINEERS, AND BUILDING OFFICIAL IN A TIMELY MANNER.
4. STRUCTURAL OBSERVATION VISITS SHALL BE PERFORMED BY A REPRESENTATIVE FROM ARW ENGINEERS IN ACCORDANCE WITH THE CONTRACT AS NEEDED TO OBSERVE THE CONSTRUCTION OF CRITICAL BUILDING ELEMENTS (I.E. FOOTINGS, BRACED FRAMES, MOMENT FRAMES, DRAG STRUTS AND THEIR CONNECTIONS, COLLECTORS, AND ROOF AND FLOOR DIAPHRAGMS). STRUCTURAL OBSERVATION REPORTS FOR EACH VISIT SHALL BE SENT DIRECTLY TO THE ARCHITECT FOR DISTRIBUTION TO THE CONTRACTOR AND BUILDING OFFICIAL. STRUCTURAL OBSERVATION VISITS SHALL NEITHER BE CONSTRUED AS SPECIAL INSPECTION NOR APPROVAL OF COMPLETED CONSTRUCTION.
5. IN ACCORDANCE WITH IBC 1704.4, THE CONTRACTOR SHALL SUBMIT A WRITTEN CONTRACTOR'S STATEMENT OF RESPONSIBILITY TO THE BUILDING OFFICIAL AND OWNER. THE STATEMENT SHALL BE SUBMITTED PRIOR TO THE CONSTRUCTION OF ANY SEISMIC/WIND-FORCE-RESISTING SYSTEM, DESIGNATED SEISMIC/WIND SYSTEM, OR COMPONENT IDENTIFIED IN THESE DOCUMENTS WITH A CIRCLE "L".

**C. BASIS OF DESIGN**

1. GOVERNING BUILDING CODE : INTERNATIONAL BUILDING CODE (IBC) 2018
2. RISK CATEGORY : II
3. WIND DESIGN
  - a. BASIC WIND SPEED (3 SECOND GUST) : 103 MPH
  - b. ALLOWABLE STRESS DESIGN WIND SPEED,  $V_{ASD}$  : 80 MPH
  - c. WIND EXPOSURE : C
  - d. INTERNAL PRESSURE COEFFICIENT,  $G_{CPI}$  : +/- 0.18
  - e. COMPONENT AND CLADDING DESIGN WIND PRESSURE SHALL BE AS REQUIRED PER ASCE 7-16.
4. SEISMIC DESIGN :
  - a. SEISMIC IMPORTANCE FACTOR,  $I_e$  : 1.0
  - b. SITE CLASS : D (SEAF1)
  - c. MAPPED SPECTRAL RESPONSE ACCELERATIONS :  $S_s = 1.360$ ,  $S_1 = 0.493$
  - d. SPECTRAL RESPONSE COEFFICIENTS :  $S_{D5} = 1.088$ ,  $S_{D1} = 0.594$
  - e. SEISMIC DESIGN CATEGORY : D
  - f. BASIC SEISMIC-FORCE-RESISTING SYSTEM : ORDINARY CONCENTRICALLY BRACED FRAME
  - g. DESIGN BASE SHEAR :  $V_{NS} = 0.335W$ ,  $V_{EW} = 0.335W$
  - h. SEISMIC RESPONSE COEFFICIENT,  $C_s$  : 0.335
  - i. RESPONSE MODIFICATION FACTOR,  $R$  : 3.25
  - j. ANALYSIS PROCEDURE : EQUIVALENT LATERAL FORCE

**D. FOUNDATION**

1. GENERAL
  - a. DESIGN SOIL PRESSURE : 1500 PSF
  - b. ALL FOOTINGS SHALL BE PLACED ON MECHANICALLY COMPACTED FILL COMPACTED TO NOT LESS THAN 95% OF MODIFIED PROCTOR DENSITY (ASTM D-1557).
  - c. UNLESS NOTED OTHERWISE, ALL CONCRETE SLABS ON EARTH SHALL BEAR ON STRUCTURAL FILL COMPACTED TO 90% OF MODIFIED PROCTOR DENSITY (ASTM D-1557).
  - d. TOP OF FOOTING ELEVATIONS SHOWN ON THE FOOTING AND FOUNDATION PLAN ARE BASED ON PRELIMINARY GRADING INFORMATION AND SHALL BE VERIFIED PRIOR TO CONSTRUCTION. STEPS WHERE SHOWN ARE AT APPROXIMATE LOCATIONS. ACTUAL STEP LOCATIONS SHALL BE AT THE CONTRACTOR'S DISCRETION BASED UPON FIELD CONDITIONS. ALL EXTERIOR FOUNDATIONS SHALL BEAR A MINIMUM OF 6 INCHES BELOW LOWEST ADJACENT FINAL GRADE.
  - e. ALL WALLS (EXCEPT CANTILEVERED RETAINING WALLS) SHALL BE ADEQUATELY BRACED AGAINST LATERAL MOVEMENT PRIOR TO BACKFILLING. DESIGN AND ERECTION OF BRACING/SHORING SHALL BE THE RESPONSIBILITY OF THE GENERAL CONTRACTOR. BRACING SHALL REMAIN IN PLACE UNTIL SUPPORTING STRUCTURAL ELEMENTS ARE IN PLACE AND HAVE ATTAINED FULL STRENGTH.
  - f. UNLESS NOTED OTHERWISE, ALL FOOTINGS AT COLUMNS SHALL BE CENTERED BELOW COLUMNS.
  - g. UNLESS NOTED OTHERWISE, ALL FOOTINGS SHALL HAVE VERTICAL FACES FORMED WITH STANDARD FORMING MATERIALS (WOOD, METAL, ETC.) WITH PRIOR APPROVAL OF ARCHITECT AND ENGINEER. CONCRETE FOR FOOTINGS CAN BE PLACED IN EXCAVATED SOIL "FORMS" PROVIDED THAT THE DIMENSIONS ARE INCREASED 3" ON ALL SIDE.

**E. CONCRETE**

1. ALL CONCRETE MIX DESIGNS SHALL COMPLY WITH THE REQUIREMENTS LISTED BELOW :
  - a. FOOTINGS, GRADE BEAMS, FOUNDATION WALLS :
    1. WHERE THE TOP OF THE ELEMENT IS EXPOSED OR IS LOCATED WITHIN 30" OF THE LOWEST ADJACENT GRADE (EXPOSURE CATEGORY F2) :
      - a. 28 DAY COMPRESSIVE STRENGTH : 4500 PSI
      - b. MAXIMUM W/C RATIO : 0.45
      - c. MAXIMUM AGGREGATE SIZE : 1"
      - d. AIR CONTENT : 4.5% +/- 1.5%
    2. WHERE THE TOP OF THE ELEMENT IS NOT EXPOSED OR IS NOT LOCATED WITHIN 30" OF THE LOWEST ADJACENT GRADE (EXPOSURE CATEGORY F0) :
      - a. 28 DAY COMPRESSIVE STRENGTH : 3000 PSI
  - b. EXTERIOR SLABS (DOCKS, ETC.) (EXPOSURE CATEGORY F2) :
    1. 28 DAY COMPRESSIVE STRENGTH : 4500 PSI
    2. MAXIMUM W/C RATIO : 0.45
    3. MAXIMUM AGGREGATE SIZE : 1"
    4. MINIMUM AIR CONTENT : 4.5% +/- 1.5%
2. WATER USED IN MIXING CONCRETE SHALL CONFORM TO ASTM C1602.
3. NO PIPES, DUCTS, SLEEVES, ETC. SHALL BE PLACED IN STRUCTURAL CONCRETE UNLESS SPECIFICALLY DETAILED OR APPROVED BY THE STRUCTURAL ENGINEER. NO ALUMINUM PRODUCTS SHALL BE EMBEDDED INTO CONCRETE. PENETRATIONS THRU STRUCTURAL CONCRETE ELEMENTS MUST BE APPROVED BY THE ENGINEER AND SHALL BE BUILT INTO THE ELEMENT PRIOR TO CONCRETE PLACEMENT.
4. REFER TO ARCHITECTURAL DRAWINGS FOR MOLDS, GROOVES, ORNAMENTS, ETC. TO BE CAST IN TO CONCRETE, AND FOR EXTENT AND LOCATION OF DEPRESSIONS, CURBS, RAMPS, ETC.
5. REINFORCING SHALL BE CONTINUOUSLY SUPPORTED AT 36" O.C. MAXIMUM SPACING.
6. UNLESS NOTED OTHERWISE, FOR NON-DETAILED OPENINGS IN CONCRETE WALLS LARGER THAN 12" AND SMALLER THAN 24" IN ANY DIRECTION ADD (2) #5 BARS ON ALL SIDES IN ADDITION TO REGULAR WALL REINFORCING AND EXTEND 24" EACH WAY BEYOND OPENING. IF 24" IS NOT AVAILABLE ON EVERY SIDE, NOTIFY STRUCTURAL ENGINEER FOR FURTHER DIRECTION. OPENINGS SHALL HAVE A MINIMUM OF 12" OF CONCRETE ABOVE THE OPENING, TOP.
7. CONSTRUCTION JOINTS NOT SHOWN ON THE PLANS SHALL BE MADE AND LOCATED SO AS TO NOT IMPAIR THE STRENGTH OF THE STRUCTURE AND AS APPROVED BY THE STRUCTURAL ENGINEER. PROVIDE 2 X 4 (SHAPED) KEYWAY IN ALL VERTICAL AND HORIZONTAL JOINTS UNLESS NOTED OR DETAILED OTHERWISE. ALL STEEL REINFORCING SHALL BE CONTINUOUS THROUGH COLD JOINTS UNLESS NOTED OTHERWISE. SEE TYPICAL DETAILS FOR COLD/CONSTRUCTION JOINTS FOR SLABS ON GRADE.
8. WHERE NEW CONCRETE IS PLACED AGAINST PREVIOUSLY HARDENED CONCRETE, THE JOINT SHALL BE CLEAN AND FREE OF LAITANCE. IMMEDIATELY BEFORE NEW CONCRETE IS PLACED, CONSTRUCTION JOINTS SHALL BE PREWETTED AND STANDING WATER REMOVED.

**F. ANCHOR BOLTS/EMBEDDED BOLTS**

1. ALL ANCHOR BOLTS SHALL HAVE ASTM A-563 HEAVY HEX NUT AND ASTM F-436 WASHERS AT STANDARD OR OVERSIZED HOLES PER AISC SPECIFICATION TABLE J3.3. WHERE HOLE SIZES DO NOT COMPLY WITH THE LIMITATIONS FOR OVERSIZED HOLES THE STRUCTURAL ENGINEER SHALL BE NOTIFIED TO DETERMINE STEEL PLATE WASHER REQUIREMENTS. ANCHOR BOLTS SHALL COMPLY WITH THE FOLLOWING :
  - a. AT BRACED FRAMES & MOMENT RESISTING FRAMES - ASTM F1554 GRADE 105 HEADED BOLTS (ASTM A449 THREADED ROD MAY BE USED WITH DOUBLE NUT AND WASHER.)
  - b. AT WOOD STUD WALLS - ASTM A-307 GRADE HEADED BOLTS. ANCHOR BOLTS IN TREATED LUMBER SHALL BE GALVANIZED OR STAINLESS STEEL. SEE TIMBER NOTES FOR MORE INFORMATION.
  - c. AT ALL OTHER ANCHOR BOLTS (UNLESS NOTED OTHERWISE) - ASTM F1554 GRADE 36 HEADED BOLTS. (ASTM A36 THREADED ROD MAY BE USED WITH DOUBLE NUT AND WASHER.)
2. EMBEDDED BOLTS IN MASONRY SHALL BE (UNLESS NOTED OTHERWISE) ASTM A-307 GRADE HEADED BOLTS.
3. SEE TYPICAL ANCHOR BOLT DETAIL FOR DEFINITIONS OF EMBEDMENT LENGTH, ETC.
4. FURNISH TEMPLATES AND OTHER DEVICES AS NECESSARY FOR PRESETTING ALL BOLTS PRIOR TO PLACING CONCRETE AND/OR GROUT.
5. IF THREADED RODS ARE USED AS PERMITTED ABOVE, THEY SHALL BE CLEAR OF SOIL AND DIRT.
6. WHERE REQUIRED FOR ERECTION, HOLES LARGER THAN OVERSIZED MAY BE PERMITTED WITH THE USE OF STEEL PLATE WASHERS AT THE DISCRETION OF THE STRUCTURAL ENGINEER.

**G. ADHESIVE/MECHANICAL ANCHORS**

1. WITHOUT WRITTEN APPROVAL OF THE ENGINEER, CONTRACTOR SHALL NOT SUBSTITUTE POST-INSTALLED ANCHORS WHERE CAST-IN-PLACE ANCHORS ARE SPECIFIED IN THE DRAWINGS.
2. WHERE STRUCTURAL DETAILS SPECIFY SPECIFIC BRANDS AND/OR TYPES OF ADHESIVES OR ANCHORS, SUBSTITUTIONS OF OTHER BRANDS AND/OR TYPES IS NOT ALLOWED, WITHOUT WRITTEN APPROVAL OF THE ENGINEER.
3. SUBSTITUTION REQUESTS FOR ALTERNATE PRODUCTS SHALL BE APPROVED IN WRITING BY THE STRUCTURAL ENGINEER OF RECORD PRIOR TO USE. SUBSTITUTION REQUESTS SHALL INCLUDE AN ICC ESR OR IAPMO REPORT AND SUPPORTING CALCULATIONS INDICATING COMPLIANCE WITH DESIGN INTENT.
4. ALL ADHESIVE/MECHANICAL ANCHORS SHALL BE INSTALLED, INCLUDING HOLE DRILLING AND PREPARATION, IN ACCORDANCE WITH AN APPROVED INDEPENDENT EVALUATION REPORT (ICC-ES, IAPMO, OR APPROVED EQUAL), AS INDICATED BELOW, AND IN ACCORDANCE WITH ALL MANUFACTURER'S PRINTED INSTALLATION INSTRUCTIONS (MPI).
5. ADHESIVE ANCHORS SHALL BE INSTALLED IN CONCRETE HAVING A MINIMUM AGE OF 21 DAYS AT TIME OF ANCHOR INSTALLATION. ADHESIVE ANCHORS SHALL NOT BE FULLY LOADED UNTIL CONCRETE HAS REACHED DESIGN STRENGTH.
6. UNLESS APPROVED BY THE ENGINEER OF RECORD, CONCRETE AND DRILLED ANCHOR HOLES SHALL BE DRY AND FREE OF WATER FOR 24 HOURS PRIOR TO ADHESIVE INSTALLATION. CONTACT THE ENGINEER OF RECORD FOR GUIDANCE IF THE CONTRACTOR CHOOSES TO INSTALL IN WET OR DAMP HOLES.
7. CONCRETE TEMPERATURE AT THE TIME OF INSTALLATION SHALL BE MONITORED BY THE CONTRACTOR. CONTRACTOR SHALL COMPLY WITH ALL MANUFACTURER'S PRINTED INSTALLATION INSTRUCTIONS (MPI) RELATIVE TO SUBSTRATE TEMPERATURE.
8. INSTALLATION OF ADHESIVE ANCHORS HORIZONTALLY OR UPWARDLY INCLINED TO SUPPORT SUSTAINED TENSION LOADS SHALL BE PERFORMED BY PERSONNEL CERTIFIED BY AN APPLICABLE CERTIFICATION PROGRAM. CERTIFICATION SHALL INCLUDE WRITTEN AND PERFORMANCE TESTS IN ACCORDANCE WITH THE ANCHOR'S ADHESIVE ANCHOR INSTALLER CERTIFICATION PROGRAM, OR EQUIVALENT IN ACCORDANCE WITH ACI 318.14 D9.2.2. PROOF OF CURRENT CERTIFICATION SHALL BE SUBMITTED TO THE ENGINEER FOR APPROVAL PRIOR TO INSTALLATION. CONTINUOUS SPECIAL INSPECTION SHALL BE PROVIDED FOR THESE ANCHORS.
9. UNLESS NOTED OTHERWISE, ALL ADHESIVE ANCHORS INTO CONCRETE SHALL BE :
  - a. HILTI HIT-RE 500V3 (ESR-3814), OR HILTI HIT-HY 200-A (ESR-3187),
  - b. SIMPSON SET-3G (ESR-4057), OR AT-XP (ER-0263),
  - c. DEWALT PURE 110+ (ESR-3298), OR AC208+ GOLD (ESR-4027-COLD WEATHER).
10. UNLESS NOTED OTHERWISE, ALL ADHESIVE ANCHORS INTO MASONRY SHALL BE :
  - a. HILTI HIT-HY 270 (ESR-4143), OR HILTI HIT-HY 200-A (ESR-3963),
  - b. SIMPSON SET-XP (ER-0265), OR AT-XP (ER-0281),
  - c. DEWALT AC100+ GOLD (ESR-3200).
11. ALL MASONRY CELLS WITHIN 8" OF THE ANCHOR SHALL BE SOLID GROUTED.
12. THE TESTING LABORATORY WILL PERFORM VISUAL INSPECTION OF ANCHORS AND DOWELS AS SPECIFIED IN THE SPECIAL INSPECTION SCHEDULE AND THE APPROVED INDEPENDENT EVALUATION REPORT. VISUAL INSPECTION IS NOT REQUIRED AT THE DIRECTION OF THE STRUCTURAL ENGINEER OF RECORD OR THE SPECIAL INSPECTOR.
13. IF REINFORCEMENT IS ENCOUNTERED DURING DRILLING, ABANDON THAT HOLE AND SHIFT THE ANCHOR LOCATION TO AVOID THE REINFORCEMENT. PROVIDE A MINIMUM SPACE OF (2) ANCHOR HOLE DIAMETERS OR 1 INCH, WHICH EVER IS LARGER, OF SOUND CONCRETE/MASONRY BETWEEN THE ANCHOR AND THE ABANDONED HOLE. FILL THE ABANDONED HOLE WITH NON-SHRINK GROUT. AT CONTRACTORS OPTION, LOCATE EXISTING REINFORCEMENT PRIOR TO DRILLING/CORING. IF THE ANCHOR OR DOWEL CANNOT BE SHIFTED AS NOTED ABOVE, THE ENGINEER WILL DETERMINE A NEW LOCATION.
14. LOCATE REINFORCEMENT AND CONFIRM FINAL ANCHOR LOCATIONS PRIOR TO FABRICATING PLATES, MEMBERS, OR OTHER STEEL ASSEMBLIES ATTACHED WITH MECHANICAL ANCHORS.

**H. REINFORCING STEEL**

1. REINFORCING BAR STRENGTH REQUIREMENTS :
  - a. WIRE FABRIC SHALL CONFORM TO ASTM STANDARD A-615 GRADE 60 AND ALL WELDED SHEETS, ADEQUATELY TIE AND SUPPORT ALL REINFORCING STEEL AS SPECIFIED BY ACI 117, TO MAINTAIN EXACT REQUIRED POSITION.
  - b. HEADED SHEAR STUD ASSEMBLIES SHALL CONFORM TO ASTM A1044.
  - c. STEEL DISCONTINUOUS FIBER REINFORCEMENT SHALL BE DEFORMED AND CONFORM TO ASTM A820 AND SHALL HAVE A LENGTH TO DIAMETER RATIO NOT SMALLER THAN 50 AND NOT GREATER THAN 100.
  - d. HEADED DEFORMED BARS SHALL CONFORM TO ASTM A970. OBSTRUCTIONS OR INTERRUPTIONS OF THE BAR DIRECTION IS, IF ANY, SHALL NOT EXTEND MORE THAN 2 BAR DIAMETERS FROM THE BEARING FACE OF THE HEAD.
2. ALL REINFORCING STEEL SHALL BE TIED IN PLACE AND ADEQUATELY SUPPORTED PRIOR TO PLACING CONCRETE. WET STABBING OF ANY REINFORCING STEEL IS NOT PERMITTED, UNLESS SPECIFICALLY DETAILED OTHERWISE OR APPROVED BY THE ENGINEER.
3. ALL FIELD BENT DOWELS SHALL BE GRADE 40 WITH SPACING INDICATED REDUCED BY 1/3.
4. UNLESS NOTED OTHERWISE, REINFORCEMENT SHALL HAVE THE FOLLOWING CONCRETE COVERAGE :
  - a. CAST AGAINST AND PERMANENTLY EXPOSED TO EARTH :
    1. #6 & LARGER : 2"
    2. #5 & SMALLER : 1-1/2"
  - b. NOT EXPOSED TO WEATHER OR EARTH :
    1. SLABS, WALLS, JOISTS, #11 & SMALLER : 3/4"
    2. BEAMS, COLUMNS: MAIN REINFORCING OR TIES : 1-1/2"
  - c. SLAB ON GRADE :
    1. PLACE REINFORCING AT CENTER OF SLAB UNLESS INDICATED OTHERWISE.
5. EXCEPT WHERE NOTED ON PLANS OR DETAILS CONTINUOUS REINFORCEMENT SHALL BE SPLICED AT POINTS OF MINIMUM STRESS BY LAPPING PER THE REBAR LAP SCHEDULE.
6. REINFORCING STEEL MAY BE SPLICED WITH MECHANICAL COUPLERS THAT HAVE A TENSION CAPACITY OF AT LEAST 125% OF THE STRENGTH OF THE BAR. MECHANICAL COUPLERS SHALL BE A POSITIVE CONNECTING TYPE COUPLER, AND SHALL BE INSTALLED IN ACCORDANCE WITH AN APPROVED ICC RESEARCH REPORT. WHERE THESE ARE USED, SPLICES ON ADJACENT BARS SHALL BE STAGGERED AT LEAST 24 INCHES ALONG THE LENGTH OF THE BARS.
7. ALL VERTICAL REINFORCING IN STRUCTURAL ELEMENTS ABOVE SHALL BE SPLICED WITH MATCHING DOWELS EMBEDDED WITHIN THE FOOTINGS OR STRUCTURE BELOW. SPLICE LENGTHS SHALL COMPLY WITH REBAR LAP SCHEDULE. DOWELS INTO FOOTINGS SHALL TERMINATE WITH A STANDARD HOOK, AND SHALL EXTEND TO WITHIN 4" OF THE BOTTOM OF THE FOOTING, BUT NEED NOT EXTEND MORE THAN 20" INTO FOOTING.
8. DO NOT WELD REINFORCING EXCEPT AS NOTED ON PLANS, WHERE REINFORCING IS WELDED, USE ASTM A-706 REINFORCING.
9. REINFORCING BARS, TIES, AND TENDONS SHALL BE SUPPORTED BY NYLON CONES, PLASTIC-COATED TIE-WIRES, OR PLASTIC-COATED CHAIRS. REINFORCING IN FOOTINGS IS PERMITTED TO BE SUPPORTED ON CONCRETE DOBIES.
10. UNLESS NOTED OTHERWISE, HOOKS, STIRRUPS, TIES, AND OTHER BENDS IN REINFORCING STEEL SHALL MEET THE STANDARDS SET FORTH IN ACI 318/318R-14. UNLESS OTHERWISE PERMITTED BY THE ENGINEER, ALL REINFORCEMENT SHALL BE BENT COLD. REINFORCEMENT PARTIALLY EMBEDDED IN CONCRETE SHALL BE FIELD BENT, EXCEPT AS SHOWN ON THESE DRAWINGS OR OTHERWISE PERMITTED BY THE ENGINEER.
11. UNLESS SPECIFICALLY NOTED AND/OR DETAILED IN THE STRUCTURAL DRAWINGS CONDUIT SHALL NOT BE IN CONTACT WITH REINFORCING STEEL.

Structural Sheet Index	
SHEET NUMBER	SHEET NAME
S001	STRUCTURAL NOTES
S002	STRUCTURAL NOTES
S003	SCHEDULES
S004	SCHEDULES
S005	SCHEDULES
S101	FOOTING AND FOUNDATION PLAN
S201	DETAILS
S202	DETAILS

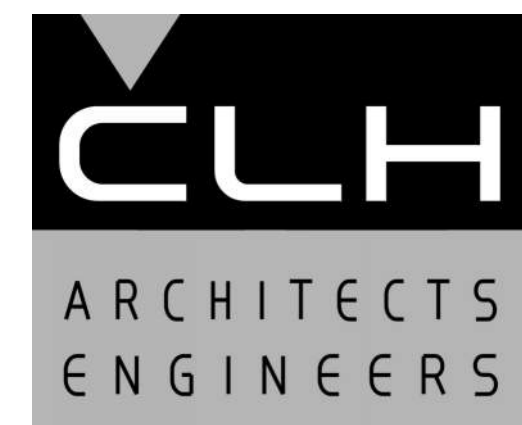

Case, Lowe & Hart, Inc. • 2484 Washington Blvd.  
Suite 510 • Ogden, Utah • 84401  
801.399.5821 • www.clhaec.com

CONSULTANTS

STAMP



New Canopy

3801 Washington Blvd.  
South Ogden, Utah

MARK	DATE	DESCRIPTION

ISSUE DATE: October 21, 2019  
PROJECT NO: 19060  
CAD DWG FILE:  
DRAWN BY: Z. Thorne  
CHK'D BY: S. Vanderdoes

REVIEW SET

October 21, 2019

SHEET TITLE

STRUCTURAL NOTES

SHEET NO:

S001

IF SHEET IS LESS THAN 22" x 34"  
IT IS A REDUCED PRINT.  
REDUCE SCALE ACCORDINGLY

X:\DRAWINGS 2019\19394 - Big Lots Canopy - v1.19.rvt

10/24/2019 9:41:05 AM



**I. STRUCTURAL STEEL**

1. STRUCTURAL STEEL SHALL BE FABRICATED AND ERECTED IN ACCORDANCE WITH THE LATEST EDITION OF THE FOLLOWING:
  - a. ANSII/AISC 360-16 "SPECIFICATION FOR STRUCTURAL STEEL BUILDINGS, WITH "COMMENTARY" AND "SUPPLEMENTS" AS REQUIRED BY BUILDING CODE.
  - b. AISC 303-16 "CODE OF STANDARD PRACTICE FOR STEEL BUILDINGS AND BRIDGES" EXCLUDING THE FOLLOWING SECTIONS: 4.4, 4.4.1, AND 4.4.2.
  - c. AISI "SPECIFICATIONS FOR THE DESIGN OF COLD-FORMED STEEL STRUCTURAL MEMBERS".
  - d. AISC "SPECIFICATION FOR STRUCTURAL JOINTS USING ASTM A325 OR A490 BOLTS".
  - e. AWS D1.1 AND 1.3 "STRUCTURAL WELDING CODE" (EXCEPT SPECIFIC ITEMS DO NOT APPLY IF THEY CONFLICT WITH AISC).
  - f. ANSII/AISC 341-16 "SEISMIC PROVISIONS FOR STRUCTURAL STEEL BUILDINGS".
  - g. AWS D1.8, "STRUCTURAL WELDING CODE - SEISMIC".
2. STRUCTURAL STEEL SHALL COMPLY WITH THE FOLLOWING:
  - a. WIDE FLANGE SHAPES AND WT SHAPES - ASTM A992
  - b. OTHER SHAPES AND PLATES - ASTM A-36 (UNO)
  - c. HOLLOW STRUCTURAL SECTIONS (HSS) - ASTM A-500, GRADE C FOR SQUARE, RECTANGULAR AND ROUND SHAPES (FY = 50 KSI FOR SQUARE AND RECTANGULAR SHAPES AND 46 KSI FOR ROUND SHAPES)
  - d. DEFORMED BAR ANCHORS (DBA) - ASTM A-496, WELDED IN ACCORDANCE WITH AWS D1.1
  - e. HEADED STUD ANCHORS (HSA) - ASTM A-108, GRADE 1015 STEEL AND WELDED IN ACCORDANCE WITH AWS D1.1 FOR TYPE "B". USE 3/4" DIAMETER STUDS, UNLESS NOTED OTHERWISE.
  - f. THREADED ROD - ASTM A-449.
  - g. NON-SHRINK GROUT - ASTM C110. NON-SHRINK GROUT SHALL BE PRE-PACKAGED, NON-METALLIC, WITH A 28-DAY COMPRESSIVE STRENGTH OF 6,000 PSI.
3. CONNECTIONS SHALL COMPLY WITH THE STRUCTURAL DRAWINGS UNLESS WRITTEN APPROVAL TO CHANGE IS GIVEN BY THE STRUCTURAL ENGINEER.
4. ALL SHOP FABRICATIONS SHALL BE PERFORMED BY AN APPROVED FABRICATOR IN ACCORDANCE WITH SECTIONS 1702 AND 1704 OF THE IBC OR WITH SHOP INSPECTION BY AN INDEPENDENT AGENCY IN ACCORDANCE WITH SECTION 1704.2.5 OF THE IBC.
5. WELDING
  - a. ALL WELDING AND CUTTING SHALL BE PERFORMED BY AWS QUALIFIED WELDERS IN ACCORDANCE WITH ANSII/AWS D1.1 (LATEST EDITION).
  - b. USE E-70XX ELECTRODES UNLESS NOTED OTHERWISE. E-60XX MAY BE USED FOR WELDING STEEL DECKES.
  - c. ALL INTERSECTING STEEL SHAPES WHICH ARE NOT CONNECTED WITH BOLTS SHALL BE WELDED TOGETHER WITH A FILLET WELD ALL AROUND UNLESS NOTED OTHERWISE. WHERE WELD SIZES ARE NOT SHOWN, USE THE FOLLOWING:
    1. WHERE THE THICKNESS OF THE CONNECTED PARTS IS EQUAL TO OR THICKER THAN 1/4", WELD SIZE SHALL BE 1/16" LESS THAN THE THICKNESS OF THE THINNEST PART.
    2. WHERE ANY OF THE CONNECTED PARTS IS LESS THAN 1/4" THICK, WELD SIZE SHALL BE THE SAME AS THE THICKNESS OF THE THINNEST PART.
  - d. WELDING OF HSA'S (HEADED STUD ANCHORS) AND DBA'S (DEFORMED BAR ANCHORS) SHALL CONFORM TO THE MANUFACTURER'S SPECIFICATIONS AND AWS D1.1 REINFORCING BARS SHALL NOT BE SUBSTITUTED FOR HSAs OR DBAs.
  - e. WHEREVER POSSIBLE, WELDS SHALL BE SHOP WELDS. SPECIAL CONSIDERATIONS, SUCH AS ITEMS WHICH MAY NEED ADJUSTMENT AT THE SITE, REQUIRE THAT SOME WELDS BE FIELD WELDS, WHERE QUESTIONS OR DISCREPANCIES OCCUR THE CONTRACTOR SHALL COORDINATE THE WORK BETWEEN THE SHOP FABRICATOR AND THE STEEL ERECTOR.
  - f. SPECIAL PROVISIONS FOR SFRS (SEISMIC FORCE RESISTING SYSTEM):
    1. ALL WELDS DESIGNATED AS DEMAND CRITICAL WELDS SHALL BE MADE WITH FILLER METALS MEETING THE REQUIREMENTS SPECIFIED IN CLAUSES 6.1, 6.2, AND 6.3 OF AWS D1.8.
    2. ALL OTHER WELDS WHICH ARE PART OF THE SFRS SHALL BE MADE WITH FILLER METALS MEETING THE REQUIREMENTS SPECIFIED IN CLAUSE 6.1 OF AWS D1.8.
    3. BUTT WELDS IN MEMBERS WITH DIFFERENT THICKNESSES, SUCH AS COLUMN SPLICES, SHALL BE TAPERED AND MADE IN SUCH A MANNER THAT THE TRANSITION DOES NOT EXCEED 1 IN 2-1/2 INCHES. THE TRANSITION SHALL BE ACCOMPLISHED BY CHAMFERING THE THICKER PART, TAPERING THE WIDER PART, SLOPING THE WELD METAL OR BY A COMBINATION OF THESE
6. BOLTING
  - a. UNLESS NOTED OTHERWISE, ALL STRUCTURAL STEEL TO STEEL CONNECTIONS SHALL USE HIGH STRENGTH BOLTS CONFORMING TO ASTM F3125 GR. A325.
  - b. UNLESS NOTED OTHERWISE, ALL BOLTING IS CLASSIFIED AS NON-SLIP CRITICAL BEARING TYPE CONNECTIONS WITH THREADS INCLUDED IN SHEAR PLANE. TIGHTEN BOLTS TO A SNUG TIGHT CONDITION, WITH ALL PLYS OF THE JOINT IN FIRM CONTACT.
  - c. WHERE OVERSIZED OR SLOTTED HOLES OCCUR IN THE OUTER PLY, AN ASTM F436 WASHER OR 5/16" THICK COMMON PLATE WASHER SHALL BE USED AS REQUIRED TO COMPLETELY COVER THE HOLES.
  - d. BOLTS SHALL BE CENTERED IN SLOTTED HOLES, UNLESS NOTED OTHERWISE.
  - e. WHERE A STEEL BEAM TO BEAM CONNECTION IS NOT SHOWN, PROVIDE AN AISC STANDARD FRAMED CONNECTION SIZED FOR 1/2 OF THE TOTAL LOAD CAPACITY OF THE BEAM FOR THE SPAN AND STEEL SPECIFIED.
7. UNLESS NOTED OTHERWISE, WHERE STEEL BEAMS SUPPORT WOOD FRAMING OR WOOD SHEATHING, PROVIDE A CONTINUOUS DOUBLE 2x OR SINGLE 3x NAILER PLATE ON THE TOP OF THE BEAM THAT EXTENDS AT LEAST THE FULL WIDTH OF THE BEAM FLANGE. ATTACH NAILER PLATES TO WIDE-FLANGE BEAMS WITH 1/2" DIAMETER THRU BOLTS AT 24" O.C. - STAGGERED. COUNTER-SINK HEAD OF BOLTS INTO TOP OF NAILER PLATE TO PROVIDE A FLUSH BEARING SURFACE.
8. PROVIDE FULL DEPTH WEB STIFFENER PLATES AT EACH SIDE OF STEEL BEAMS AT ALL BEARING (EXCEPT SECONDARY FRAMING) POINTS. STIFFENER PLATES SHALL BE THICKNESS SHOWN UNLESS NOTED OTHERWISE AND SHALL BE WELDED BOTH SIDES WITH FILLET WELDS ALL AROUND. FLANGE WIDTH STIFFENER THICKNESS WELD THICKNESS
 

< 8 1/4"	14"	3/16"
8 1/4" < BF < 12 1/2"	3/8"	1/4"
12 1/2" < BF < 18"	1/2"	5/16"
9. FABRICATORS AND SUPPLIERS SHALL COORDINATE PAINT/FINISHES WITH REQUIREMENTS FOR DIRECT APPLIED INSULATION, FIREPROOFING, ETC. AS NOTED IN THE PROJECT SPECIFICATIONS.
10. WHEN DETERMINING THE FIRE RESISTANCE OF ASSEMBLIES, USE THE FOLLOWING: STEEL ROOF MEMBERS ARE CONSIDERED UN-RESTRAINED AND STEEL FLOOR FRAMING MEMBERS ARE CONSIDERED RESTRAINED.
11. UNLESS NOTED OTHERWISE, ALL HORIZONTAL FRAMING MEMBERS SHALL BE ERECTED WITH THE NATURAL CROWN UP.
12. UNLESS OTHERWISE SHOWN OR DETAILED IN THE PLANS, ALL STEEL COLUMNS, BEAMS, BRACES, STRUTS, ETC. SHALL BE CONTINUOUS BETWEEN CONNECTIONS OR SUPPORTS. SPLICES IN MEMBERS SHALL NOT BE PERMITTED WITHOUT WRITTEN APPROVAL BY THE ENGINEER OF RECORD.

**J. NON-STRUCTURAL DELEGATED DESIGNS AND DEFERRED SUBMITTALS**

1. NON-STRUCTURAL DELEGATED DESIGNS AND SUBSEQUENT DEFERRED SUBMITTALS ARE FOR ITEMS NOT INCLUDED IN THE STRUCTURAL DELEGATED DESIGN SECTION, THESE ARE ITEMS THAT ARE NOT CRITICAL TO THE OVERALL PERFORMANCE OF THE STRUCTURAL SYSTEM BUT THAT IMPART LOADS AND FORCES TO THE STRUCTURAL SYSTEM.
2. NON-STRUCTURAL DEFERRED SUBMITTALS SHALL BEAR THE STAMP AND SIGNATURE OF THE DESIGN PROFESSIONAL RESPONSIBLE FOR THE DESIGN.
3. ARW ENGINEERS WILL REVIEW NON-STRUCTURAL DEFERRED SUBMITTALS TO VERIFY DESIGN CRITERIA IS COMPLIANT WITH THE APPROVED CONSTRUCTION DOCUMENTS.
4. IF THE STRUCTURAL DRAWINGS INCLUDE LOADS TO ACCOMMODATE NON-STRUCTURAL ELEMENTS, THE CONTRACTOR SHALL SUBMIT DOCUMENTATION INDICATING THAT THE NON-STRUCTURAL ELEMENTS COMPLY WITH THE LOADING CRITERIA PROVIDED HEREIN. SUCH DOCUMENTATION SHALL BEAR THE STAMP AND SIGNATURE OF THE DESIGN PROFESSIONAL RESPONSIBLE FOR THE DESIGN.
5. IF THE NON-STRUCTURAL DEFERRED SUBMITTAL INDICATES THAT THE ELEMENT WILL IMPART FORCES IN EXCESS OF THOSE INDICATED ON THE STRUCTURAL DRAWINGS, THE CONTRACTOR SHALL SUBMIT A DETAILED GRAPHICAL REPRESENTATION OF THOSE DESIGN LOADS, INCLUDING MAGNITUDE, AND LOCATION. THE GRAPHIC SHALL BE ACCOMPANIED BY DOCUMENTATION INDICATING THAT THE NON-STRUCTURAL ELEMENT DESIGN COMPLIES WITH THE LOADING CRITERIA PROVIDED HEREIN. THE LETTER SHALL BEAR THE STAMP AND SIGNATURE OF THE DESIGN PROFESSIONAL RESPONSIBLE FOR THE DESIGN.
6. NON-STRUCTURAL DELEGATED DESIGN ITEMS REQUIRING DEFERRED SUBMITTALS SHALL INCLUDE, BUT ARE NOT LIMITED TO:
  - a. COLD FORMED STEEL STUDS / JOISTS / HEADERS / JAMBS / TRUSSES.
  - b. SEISMIC BRACING OF ALL ARCHITECTURAL, MECHANICAL, PLUMBING, AND ELECTRICAL ITEMS WHERE REQUIRED BY THE MOST RECENT VERSION OF ASCE 7 AND THE PROJECT CONTRACT DOCUMENTS.

**K. EXISTING BUILDING NOTES**

1. ARW ENGINEERS EXPRESSLY DISCLAIMS RESPONSIBILITY FOR ANY PORTION OF THE EXISTING BUILDING NOT SPECIFICALLY ADDRESSED IN THESE DRAWINGS.
2. DRAWINGS AND DETAILS HAVE BEEN PREPARED TO REFLECT THE EXISTING CONDITIONS AND CONFIGURATIONS OF STRUCTURAL ELEMENTS. HOWEVER, THE CONTRACTOR IS ULTIMATELY RESPONSIBLE FOR VERIFYING ALL EXISTING CONDITIONS AND ALERTING THE ENGINEER OF ANY DISCREPANCIES FOUND PRIOR TO FABRICATING OR INSTALLING STRUCTURAL ELEMENTS.
3. THE CONTRACTOR IS RESPONSIBLE FOR MAKING SURE THAT THE BUILDING AND ELEMENTS WITHIN THE BUILDING REMAIN STABLE UNTIL CONSTRUCTION IS COMPLETE. AT NO ADDITIONAL COST TO THE OWNER, THE CONTRACTOR SHALL BE RESPONSIBLE FOR PROVIDING SHORING OR OTHER TEMPORARY SUPPORT OF STRUCTURAL MEMBERS UNTIL THE FINAL CONFIGURATION HAS BEEN COMPLETED.

**LEGEND OF SYMBOLS AND ABBREVIATIONS**

AB	= ANCHOR BOLT		FOOTING MARK
ABV	= ABOVE		TOP OF FOOTING ELEV.
ARCH	= ARCHITECT		SECTION MARK
BLW	= BELOW		SHEET NUMBER
BN	= BOUNDARY NAILING		TOP OF FOUNDATION WALL OR COLUMN PIER ELEV.
BRB	= BUCKLING RESTRAINED BRACE		SHEAR WALL - SEE SCHEDULE
BRBF	= BUCKLING RESTRAINED BRACE FRAME		MIN. LENGTH OF SHEAR WALL
CJP	= COMPLETE JOINT PENETRATION		FOOTING STEP
CL	= CENTERLINE		MASONRY WALL
CMU	= CONCRETE MASONRY UNIT		MASONRY WALL W/ CONCRETE FOUNDATION BELOW
COL	= COLUMN		DEPRESS FDN./WALL AND POUR FLOOR SLAB OVER AT MASONRY FOUNDATION WALL
CONC	= CONCRETE		DEPRESS FDN./WALL AND POUR FLOOR SLAB OVER AT CONCRETE FOUNDATION WALL
CP	= CONCRETE PIER		MASONRY BEAM
DC	= DEMAND CRITICAL		CONCRETE BEAM
DIA / Ø	= DIAMETER		HD - SIMPSON HOLDOWN SIZE POST - SIZE OF END POST CONNECTED TO HOLDOWN "A" - PLAN CONFIGURATION AT HOLDOWN AT FOUNDATION
DBA	= DEFORMED BAR ANCHOR		FRAMING ANGLE SEE TYPICAL DETAIL
DBE	= DECK BEARING ELEVATION		FRAMING CHANNEL SEE TYPICAL DETAIL
ELEV	= ELEVATION		ITEMS, DETAILS, & SYSTEMS WHICH ARE PART OF THE LATERAL FORCE RESISTING SYSTEM.
EN	= EDGE NAILING		MOMENT RESISTING CONNECTIONS - SEE DETAIL
EOD	= EDGE OF DECK		MOMENT RESISTING CANTILEVER CONNECTIONS - SEE DETAIL
FDN	= FOUNDATION		KICKER BRACE
FTG	= FOOTING		
FFE	= FINISHED FLOOR ELEVATION		
GB	= CONCRETE GRADE BEAM		
HSA	= HEADED STUD ANCHOR		
JBE	= JOIST BEARING ELEVATION		
KB	= KICKER BRACE		
MAX	= MAXIMUM		
MB	= MASONRY BEAM		
MC	= MASONRY COLUMN		
MECH	= MECHANICAL		
MEZZ	= MEZZANINE		
MIN	= MINIMUM		
MJ	= MASONRY JAMB		
MW	= MASONRY WALL		
NS, FS	= NEAR SIDE, FAR SIDE		
OAE	= OR APPROVED EQUAL		
OPP	= OPPOSITE		
PAF	= POWDER ACTUATED FASTENER		
PL	= PLATE		
REINF	= REINFORCING		
REQ'D	= REQUIRED		
SIM	= SIMILAR		
SSH	= STEEL STUD HEADER		
SSJ	= STEEL STUD JAMB		
SSS	= STEEL STUD SILL		
SSW	= STEEL STUD WALL		
TOB	= TOP OF BEAM ELEVATION		
TOC	= TOP OF CONCRETE SLAB		
TOF	= TOP OF FOOTING		
TOG	= TOP OF GIRDER ELEVATION		
TOM	= TOP OF MASONRY		
TOS	= TOP OF STEEL ELEVATION		
TYP	= TYPICAL		
UNO	= UNLESS NOTED OTHERWISE		

**BEAM CONNECTION SCHEDULE**

BEAM DEPTH	SHEAR PLATE INFORMATION			BOLTS W/ STANDARD WASHERS OVER SLOTS		WELD "A"	COMMENTS
	PL. DIMENSIONS W/ SHORT SLOTTED HOLES	Lev	Leh	No.	SIZE		
W8 x, W10 x	PL. 1/4" x 4"	1 1/2"	2"	2	3/4" Ø	3/16"	
W12 x	PL. 5/16" x 4"	1 1/2"	2"	3	3/4" Ø	1/4"	
W14 x 90 & LIGHTER	PL. 5/16" x 4"	1 1/2"	2"	3	3/4" Ø	1/4"	
W16 x 77 & LIGHTER	PL. 5/16" x 4"	1 1/2"	2"	4	3/4" Ø	1/4"	
W18 x 65 & LIGHTER	PL. 5/16" x 4"	1 1/2"	2"	5	3/4" Ø	1/4"	
W21 x 73 & LIGHTER	PL. 5/16" x 4"	1 1/2"	2"	6	3/4" Ø	1/4"	
W24 x 94 & LIGHTER	PL. 3/8" x 4"	1 1/2"	2"	7	7/8" Ø	1/4"	
W27 x 114 & LIGHTER	PL. 3/8" x 4"	1 1/2"	2"	7	7/8" Ø	1/4"	
W30 x 124 & LIGHTER	PL. 1/2" x 4"	1 3/4"	2"	8	1" Ø	5/16"	
W33 x 130 & LIGHTER	PL. 1/2" x 4"	1 3/4"	2"	9	1" Ø	5/16"	
W36 x 160 & LIGHTER	PL. 1/2" x 4 1/2"	2"	2 1/4"	10	1-1/8" Ø	5/16"	

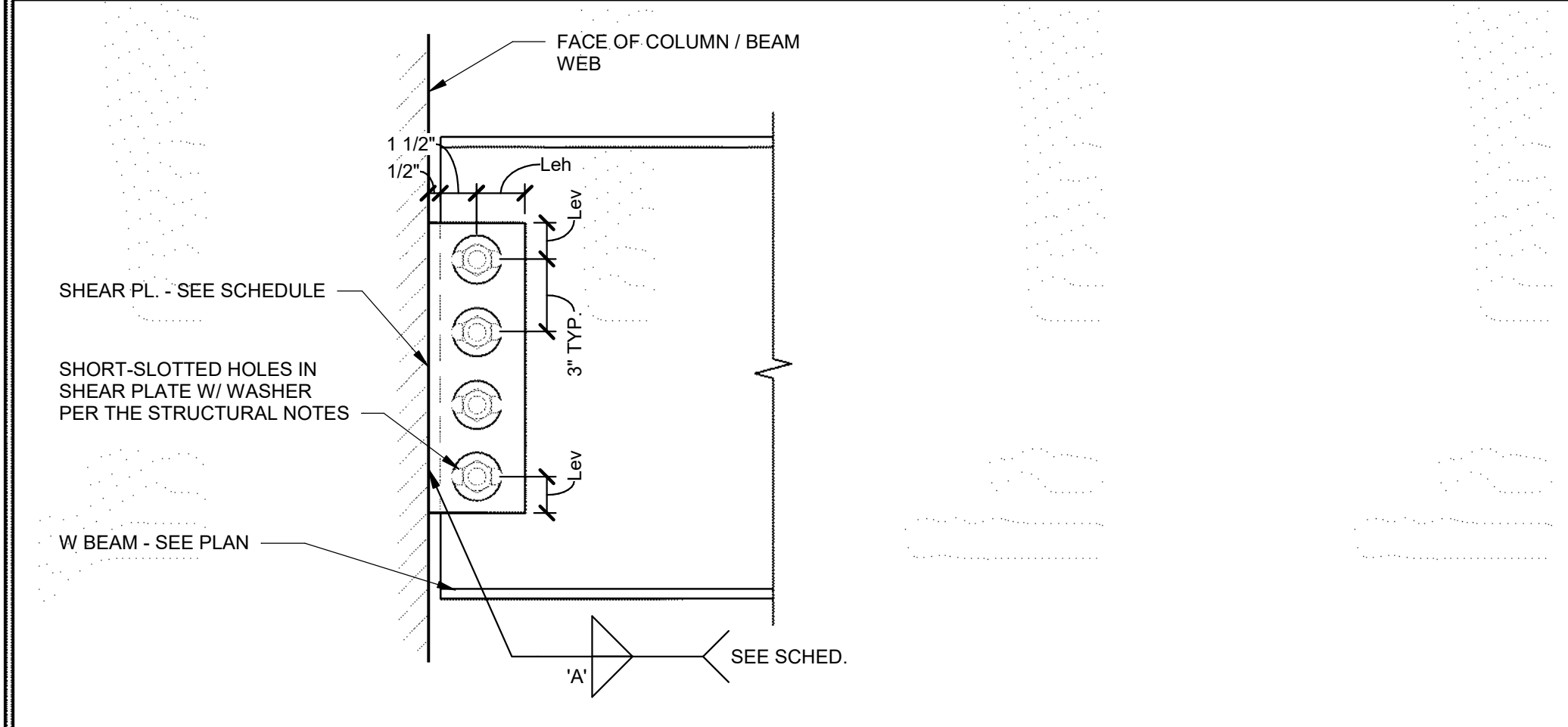

Case, Lowe & Hart, Inc. • 2484 Washington Blvd.  
Suite 510 • Ogden, Utah • 84401  
801.399.5821 • www.clhaec.com

**CONSULTANTS**

Blank area for consultants.

**STAMP**

Blank area for stamp.



New Canopy  
3801 Washington Blvd.  
South Ogden, Utah

**MARK DATE DESCRIPTION**

MARK	DATE	DESCRIPTION

ISSUE DATE: October 21, 2019  
PROJECT NO: 19060  
CAD DWG FILE:  
DRAWN BY: Z. Thorne  
CHK'D BY: S. Vanderdoes

**REVIEW SET**  
October 21, 2019

**SHEET TITLE**

**STRUCTURAL NOTES**

**SHEET NO:**

S002

X:\DRAWINGS 2019\19394 - Big Lots Canopy - v1.0.rvt

IF SHEET IS LESS THAN 22" x 34"  
IT IS A REDUCED PRINT.  
REDUCE SCALE ACCORDINGLY



## 2018 IBC CONCRETE REBAR LAP SPLICE SCHEDULE

FOR CONCRETE APPLICATIONS (ACI 318 - 14)

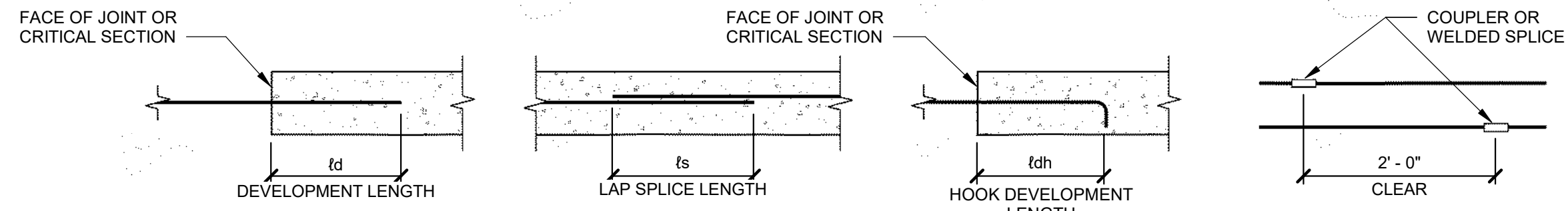

BAR LOCATION	CONCRETE		CONCRETE REINFORCING & SPLICE LENGTHS (IN)																								COMMENTS				
	TYPE	STRENGTH	BAR SIZE																												
			#3			#4			#5			#6			#7			#8			#9			#10				#11			
td	ts	tdh	td	ts	tdh	td	ts	tdh	td	ts	tdh	td	ts	tdh	td	ts	tdh	td	ts	tdh	td	ts	tdh	td	ts	tdh	td	ts	tdh		
VERT. WALL BARS, FILL ON METAL DECK	NWC	3000 PSI	17	22	8	22	29	8	28	36	10	33	43	12	48	62	13	55	72	15	62	17	69	19	76	30					
HORIZ. WALL BARS, FOOTING TOP BARS	NWC	3000 PSI	17	22	8	22	29	8	28	36	10	33	43	12	48	62	13	55	72	15	62	17	69	19	76	30					
BEAM BOTTOM BARS, COLUMN BARS	NWC	3000 PSI	17	22	8	22	29	11	28	36	14	33	43	16	48	62	19	55	72	22	62	25	69	27	76	30					
FOOTING BOTTOM BARS	NWC	3000 PSI	12	16	8	14	18	8	17	22	10	20	26	12	29	38	13	33	43	15	37	17	42	19	46	30					
BEAM TOP BARS	NWC	3000 PSI	22	29	8	29	38	11	36	47	14	43	56	16	63	82	19	72	94	22	81	25	90	27	98	30					
SLAB ON GRADE	NWC	3000 PSI	12	16	8	14	18	8	17	22	10	20	26	12	32	42	13	42	55	15	53	17	69	19	76	30					

BAR LOCATION	CONCRETE		CONCRETE REINFORCING & SPLICE LENGTHS (IN)																								COMMENTS					
	TYPE	STRENGTH	BAR SIZE																													
			#3			#4			#5			#6			#7			#8			#9			#10				#11				
td	ts	tdh	td	ts	tdh	td	ts	tdh	td	ts	tdh	td	ts	tdh	td	ts	tdh	td	ts	tdh	td	ts	tdh	td	ts	tdh	td	ts	tdh	td	ts	tdh
VERT. WALL BARS, FILL ON METAL DECK	NWC	4000 PSI	15	20	7	19	25	7	24	31	8	29	38	10	42	55	12	48	62	13	54	15	60	17	66	26						
HORIZ. WALL BARS, FOOTING TOP BARS	NWC	4000 PSI	15	20	7	19	25	7	24	31	8	29	38	10	42	55	12	48	62	13	54	15	60	17	66	26						
BEAM BOTTOM BARS, COLUMN BARS	NWC	4000 PSI	15	20	7	19	25	9	24	31	12	29	38	14	42	55	17	48	62	19	54	21	60	24	66	26						
FOOTING BOTTOM BARS	NWC	4000 PSI	12	16	7	12	16	7	15	20	8	18	23	10	25	33	12	29	38	13	33	15	36	17	40	26						
BEAM TOP BARS	NWC	4000 PSI	19	25	7	25	33	9	31	40	12	37	48	14	54	70	17	62	81	19	70	21	78	24	85	26						
SLAB ON GRADE	NWC	4000 PSI	12	16	7	12	16	7	15	20	8	18	23	10	28	36	12	36	47	13	46	15	60	17	66	26						

BAR LOCATION	CONCRETE		CONCRETE REINFORCING & SPLICE LENGTHS (IN)																								COMMENTS					
	TYPE	STRENGTH	BAR SIZE																													
			#3			#4			#5			#6			#7			#8			#9			#10				#11				
td	ts	tdh	td	ts	tdh	td	ts	tdh	td	ts	tdh	td	ts	tdh	td	ts	tdh	td	ts	tdh	td	ts	tdh	td	ts	tdh	td	ts	tdh	td	ts	tdh
VERT. WALL BARS, FILL ON METAL DECK	NWC	4500 PSI	14	18	7	18	23	6	23	30	8	27	35	9	40	52	11	45	59	13	51	14	56	16	62	25						
HORIZ. WALL BARS, FOOTING TOP BARS	NWC	4500 PSI	14	18	7	18	23	6	23	30	8	27	35	9	40	52	11	45	59	13	51	14	56	16	62	25						
BEAM BOTTOM BARS, COLUMN BARS	NWC	4500 PSI	14	18	7	18	23	9	23	30	11	27	35	13	40	52	16	45	59	18	51	20	56	22	62	25						
FOOTING BOTTOM BARS	NWC	4500 PSI	12	16	7	12	16	6	14	18	8	17	22	9	24	31	11	27	35	13	31	14	34	16	37	25						
BEAM TOP BARS	NWC	4500 PSI	18	23	7	24	31	9	30	39	11	35	46	13	51	66	16	59	77	18	66	20	73	22	80	25						
SLAB ON GRADE	NWC	4500 PSI	12	16	7	12	16	6	14	18	8	17	22	9	27	35	11	34	44	13	44	14	56	16	62	25						

BAR LOCATION	CONCRETE		CONCRETE REINFORCING & SPLICE LENGTHS (IN)																								COMMENTS					
	TYPE	STRENGTH	BAR SIZE																													
			#3			#4			#5			#6			#7			#8			#9			#10				#11				
td	ts	tdh	td	ts	tdh	td	ts	tdh	td	ts	tdh	td	ts	tdh	td	ts	tdh	td	ts	tdh	td	ts	tdh	td	ts	tdh	td	ts	tdh	td	ts	tdh
VERT. WALL BARS, FILL ON METAL DECK	NWC	5000 PSI	13	17	6	17	22	6	22	29	7	26	34	9	38	49	10	43	56	12	48	13	54	15	59	23						
HORIZ. WALL BARS, FOOTING TOP BARS	NWC	5000 PSI	13	17	6	17	22	6	22	29	7	26	34	9	38	49	10	43	56	12	48	13	54	15	59	23						
BEAM BOTTOM BARS, COLUMN BARS	NWC	5000 PSI	13	17	6	17	22	8	22	29	11	26	34	13	38	49	15	43	56	17	48	19	54	21	59	23						
FOOTING BOTTOM BARS	NWC	5000 PSI	12	16	6	12	16	6	13	17	7	16	21	9	23	30	10	26	34	12	29	13	32	15	36	23						
BEAM TOP BARS	NWC	5000 PSI	17	22	6	23	30	8	28	36	11	34	44	13	49	64	15	56	73	17	63	19	69	21	76	23						
SLAB ON GRADE	NWC	5000 PSI	12	16	6	12	16	6	13	17	7	16	21	9	25	33	10	32	42	12	41	13	54	15	59	23						

- NOTES:
- MECHANICAL COUPLERS MAY BE USED IN LIEU OF LAP SPLICES SHOWN. SEE STRUCTURAL NOTES FOR MINIMUM COUPLER CAPACITY. WHERE MECHANICAL COUPLERS ARE USED, STAGGER ADJACENT SPLICES A MINIMUM OF 24" AS INDICATED ABOVE.
  - DEVELOPMENT LENGTHS SHALL BE INCREASED BY 50% FOR STRAIGHT BAR DEVELOPMENT AND 20% FOR HOOKED BARS WHERE EPOXY COATING IS USED.
  - WHEN SPLICING BARS OF DIFFERENT SIZES, USE LAP SPLICE LENGTH OF LARGER BARS UNO.
  - SPLICE BARS LARGER THAN #11 USING MECHANICAL COUPLERS.

## STANDARD HOOK & BEND SCHEDULE

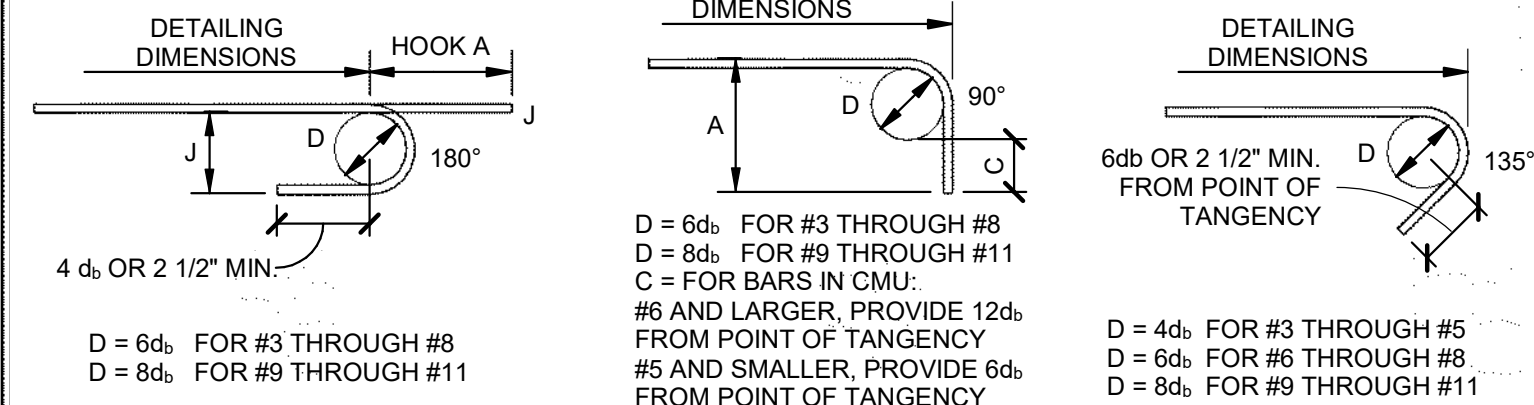

BAR SIZE	DIMENSION OF STANDARD 180° HOOKS, ALL GRADES		DIMENSION OF STANDARD 90° HOOKS, ALL GRADES	
	A	J	A	
#3	5"	3"	6"	
#4	6"	4"	8"	
#5	7"	5"	10"	
#6	8"	6"	1'-0"	
#7	10"	7"	1'-2"	
#8	11"	8"	1'-4"	
#9	1'-3"	11 3/4"	1'-7"	
#10	1'-5"	1'-1 1/4"	1'-10"	
#11	1'-7"	1'-2 3/4"	2'-0"	

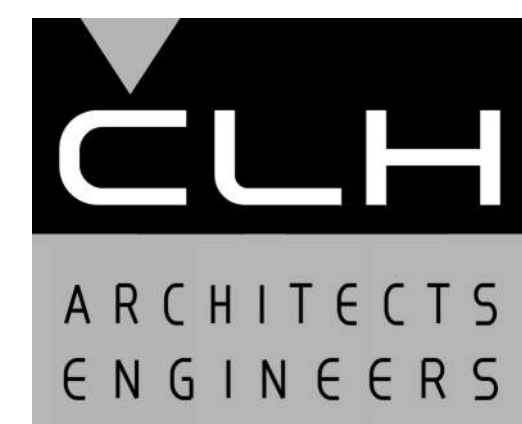

Case, Lowe & Hart, Inc. • 2484 Washington Blvd.  
Suite 510 • Ogden, Utah • 84401  
801.399.5821 • www.clhaec.com

CONSULTANTS

STAMP

3801 Washington Blvd.  
South Ogden, Utah

MARK	DATE	DESCRIPTION

ISSUE DATE: October 21, 2019  
PROJECT NO: 19060  
CAD DWG FILE:  
DRAWN BY: Z. Thomer  
CHK'D BY: S. Vanderdoes

REVIEW SET  
October 21, 2019

SHEET TITLE  
SCHEDULES

SHEET NO:  
S003

IF SHEET IS LESS THAN 22" x 34"  
IT IS A REDUCED PRINT.  
REDUCE SCALE ACCORDINGLY

X:\DRAWINGS\2019\09394 - Big Lots Canopy\S-19394 - Big Lots Canopy - v1.0.rvt 10/24/2019 9:41:11 AM



**STRUCTURAL STEEL SPECIAL INSPECTION SCHEDULE**

ESTABLISHED PER 2018 IBC SECTION 1705.2.1

INSPECTION TASKS PRIOR TO WELDING (TABLE N5.4-1)	FABRICATOR QUALITY CONTROL		SPECIAL INSPECTOR QUALITY ASSURANCE		NOTES	INSPECTION TASKS PRIOR TO BOLTING (TABLE N5.6-1)	CONTINUOUS	PERIODIC	CONTINUOUS	PERIODIC	NOTES	
	CONTINUOUS	PERIODIC	CONTINUOUS	PERIODIC								
WELDER QUALIFICATION RECORDS AND CONTINUITY RECORDS	•			•		MANUFACTURER'S CERTIFICATIONS AVAILABLE FOR FASTENER MATERIALS			•		1. PERIODIC - OBSERVE THESE ITEMS ON A RANDOM BASIS. OPERATIONS NEED NOT BE DELAYED PENDING THESE INSPECTIONS. 2. CONTINUOUS - PERFORM THESE TASKS FOR EACH BOLTED CONNECTION. 3. CONTINUOUS - QUALITY CONTROL (QC) SHALL BE PROVIDED BY THE FABRICATOR AND ERECTOR. 4. QUALITY ASSURANCE (QA) SHALL BE PROVIDED BY OTHERS WHEN REQUIRED BY THE AUTHORITY HAVING JURISDICTION (AHJ), APPLICABLE BUILDING CODE (ABC), PURCHASER, OWNER, OR ENGINEER OF RECORD (EOR). NONDESTRUCTIVE TESTING (NDT) SHALL BE PERFORMED BY THE AGENCY OR FIRM RESPONSIBLE FOR QUALITY ASSURANCE, EXCEPT AS PERMITTED IN ACCORDANCE WITH SECTION N6. 5. NONDESTRUCTIVE TESTING PERSONNEL SHALL BE QUALIFIED IN ACCORDANCE WITH AISC 360-16 CHAPTER N6. 6. NONDESTRUCTIVE TESTING PERSONNEL SHALL BE QUALIFIED IN ACCORDANCE WITH AISC 360-16 CHAPTER N4.3. 7. NONDESTRUCTIVE TESTING OF WELDED JOINTS SHALL COMPLY WITH AISC 360-16 CHAPTER N5.5a AND b. 8. OBSERVATION OF WELDING OPERATIONS AND VISUAL INSPECTION OF IN-PROCESS AND COMPLETED WELDS SHALL BE THE PRIMARY METHOD TO CONFIRM THAT THE MATERIALS, PROCEDURES AND WORKMANSHIP ARE IN CONFORMANCE WITH THE CONSTRUCTION DOCUMENTS. FOR STRUCTURAL STEEL, ALL PROVISIONS OF AWS D1.1 / D1.1M STRUCTURAL WELDING CODE - STEEL FOR STATICALLY LOADED STRUCTURES SHALL APPLY. 9. THERMALLY CUT SURFACES OF ACCESS HOLES SHALL BE TESTED BY QA USING MT OR PT, WHEN THE FLANGE THICKNESS EXCEEDS 2 IN. (50mm) OR WHEN THE WELD THICKNESS EXCEEDS 2 IN. (50mm) FOR BUILT-UP SHAPES. ANY CRACK SHALL BE DEEMED UNACCEPTABLE REGARDLESS OF SIZE OR LOCATION. 10. WHEN REQUIRED BY APPENDIX 3, TABLE A-3.1, WELDED JOINTS REQUIRING WELD SOUNDNESS TO BE ESTABLISHED BY RADIOGRAPHICS OR ULTRASONIC INSPECTION SHALL BE TESTED BY QA AS PRESCRIBED. REDUCTION IN THE RATE OF UT IS PROHIBITED. 11. REDUCTION OF RATE OF ULTRASONIC TESTING - THE RATE OF UT IS ONLY PERMITTED TO BE REDUCED IF APPROVED BY THE EOR AND THE AHJ PER AISC 360-16 CHAPTER N5.5e. 12. FOR STRUCTURES IN RISK CATEGORY II, WHERE THE INITIAL RATE FOR UT IS 10%, THE NDT RATE FOR AN INDIVIDUAL WELDER OR WELDING OPERATOR SHALL BE INCREASED TO 100% SHOULD THE REJECT RATE, THE NUMBER OF WELDS CONTAINING UNACCEPTABLE DEFECTS DIVIDED BY THE NUMBER OF WELDS COMPLETED, EXCEEDS 5% OF THE WELDS TESTED FOR THE WELDER OR WELDING OPERATOR. A SAMPLING OF AT LEAST 20 COMPLETED WELDS FOR A JOB SHALL BE MADE PRIOR TO IMPLEMENTING SUCH AN INCREASE. WHEN THE REJECT RATE FOR THE WELDER OR WELDING OPERATOR, AFTER A SAMPLING OF AT LEAST 40 COMPLETED WELDS, HAS FALLEN TO 5% OR LESS, THE RATE OF UT SHALL BE RETURNED TO 10%. FOR EVALUATING THE REJECT RATE OF CONTINUOUS WELDS OVER 3 FT (1M) IN LENGTH WHERE THE EFFECTIVE THROAT IS 1 IN. (25mm) OR LESS, EACH 12 IN. (300mm) INCREMENT OR FRACTION THEREOF SHALL BE CONSIDERED AS ONE WELD. FOR EVALUATING THE REJECT RATE ON CONTINUOUS WELDS OVER 3 FT (1M) IN LENGTH WHERE THE EFFECTIVE THROAT IS GREATER THAN 1 IN. (25mm), EACH 6 IN. (150mm) OF LENGTH OR FRACTION THEREOF SHALL BE CONSIDERED ON WELD. 13. ALL NDT PERFORMED SHALL BE DOCUMENTED. FOR SHOP FABRICATION, THE NDT REPORT SHALL IDENTIFY THE TESTED WELD BY PIECE MARK AND LOCATION IN THE PIECE. FOR FIELD WORK, THE NDT REPORT SHALL IDENTIFY THE TESTED WELD BY LOCATION IN THE STRUCTURE, PIECE MARK, AND LOCATION IN THE PIECE. WHEN A WELD IS REJECTED ON THE BASIS OF NDT, THE NDT RECORD SHALL INDICATE THE LOCATION OF THE DEFECT AND THE BASIS OF REJECTION. 14. DEMAND CRITICAL WELDS SHALL MEET THE PROVISION FOUND IN AISC 341-16 AND WELDING METHODS, PROCEDURES AND QUALITY CONTROL SHALL COMPLY WITH AWS D1.1 AND THE FOLLOWING: a. ARC STRIKES, GOUGES AND OTHER IMPERFECTIONS WITHIN OR ADJACENT TO THE JOINT, SHALL BE REPAIRED OR REMOVED. b. PREHEAT AND INTER-PASS REQUIREMENTS AS OUTLINED IN SECTION 3.5. c. UNREPAIRED CRACKS, GOUGES, AND NOTCHES WILL NOT BE PERMITTED IN THE JOINT AREA. d. USE ELECTRODES WITH CHARPY V-NOTCH ABSORBED ENERGY EQUAL TO OR GREATER THAN 20 FT-LBS AT 20 DEGREES FAHRENHEIT UNDER AWS A5 CLASSIFICATION TEST METHODS, AND 40 FT-LBS AT 70 DEGREES FAHRENHEIT USING TEST PROCEDURES PRESCRIBED IN APPENDIX X OF AISC 358. ACCEPTABLE ELECTRODES INCLUDE E70TG-K2, E71 T-1.	
WELDING PROCEDURE SPECIFICATIONS (WPSs) AVAILABLE	•			•		FASTENERS MARKED IN ACCORDANCE WITH ASTM REQUIREMENTS						
MANUFACTURER CERTIFICATIONS FOR WELDING CONSUMABLES AVAILABLE	•			•		PROPER FASTENERS SELECTED FOR THE JOINT DETAIL (GRADE, TYPE, BOLT LENGTH IF THREADS ARE TO BE EXCLUDED FROM SHEAR PLANE)						
MATERIAL IDENTIFICATION (TYPE / GRADE)		•				PROPER BOLTING PROCEDURES SELECTED FOR JOINT DETAIL						
WELDER IDENTIFICATION SYSTEM <sup>1</sup>				•		CONNECTING ELEMENTS, INCLUDING THE APPROPRIATE FAYING SURFACE CONDITION AND HOLE PREPARATION, IF SPECIFIED, MEET APPLICABLE REQUIREMENTS						
FIT-UP OF GROOVE WELDS (INCLUDING JOINT GEOMETRY)				•		PRE-INSTALLATION VERIFICATION TESTING BY INSTALLATION PERSONNEL OBSERVED AND DOCUMENTED FOR FASTENER ASSEMBLIES AND METHODS USED						
* JOINT PREPARATION				•		PROPER STORAGE PROVIDED FOR BOLTS, NUTS, WASHERS AND OTHER FASTENER COMPONENTS						
* DIMENSIONS (ALIGNMENT, ROOT OPENING, ROOT FACE, BEVEL)				•		<b>INSPECTION TASKS DURING BOLTING (TABLE N5.6-2)</b>		CONTINUOUS	PERIODIC	CONTINUOUS		PERIODIC
* CLEANLINESS (CONDITION OF STEEL SURFACES)				•		FASTENER ASSEMBLIES, PLACED IN ALL HOLES AND WASHERS (IF REQUIRED) ARE POSITIONED AS REQUIRED						
* TACKING (TACK WELD QUALITY AND LOCATION)				•		JOINT BROUGHT TO THE SNUG-TIGHT CONDITION PRIOR TO THE PRETENSIONING OPERATION						
* BACKING TYPE AND FIT (IF APPLICABLE)				•		FASTENER COMPONENT NOT TURNED BY THE WRENCH PREVENTED FROM ROTATING						
FIT-UP OF CJP GROOVE WELDS OFHSS T-, Y-, AND K-JOINTS WITHOUT BACKING (INCLUDING JOINT GEOMETRY)				•		FASTENERS ARE PRETENSIONED IN ACCORDANCE WITH THE RCSC SPECIFICATION, PROGRESSING SYSTEMATICALLY FROM THE MOST RIGID POINT TOWARD THE FREE EDGES						
* JOINT PREPARATIONS				•		<b>INSPECTION TASKS AFTER BOLTING (TABLE N5.6-3)</b>		CONTINUOUS	PERIODIC	CONTINUOUS		PERIODIC
* DIMENSIONS (ALIGNMENT, ROOT OPENING, ROOT FACE, BEVEL)				•		DOCUMENT ACCEPTANCE OR REJECTION OF BOLTED CONNECTIONS						
* CLEANLINESS (CONDITION OF STEEL SURFACES)				•								
* TACKING (TACK WELD QUALITY AND LOCATION)				•								
CONFIGURATION AND FINISH OF ACCESS HOLES				•								
FIT-UP OF FILLET WELDS				•								
* DIMENSIONS (ALIGNMENT, GAPS AT ROOT)				•								
* CLEANLINESS (CONDITION OF STEEL SURFACES)				•								
* TACKING (TACK WELD QUALITY AND LOCATION)				•								
CHECK WELDING EQUIPMENT				•								
<sup>1</sup> THE FABRICATOR OR ERECTOR, AS APPLICABLE, SHALL MAINTAIN A SYSTEM BY WHICH A WELDER WHO HAS WELDED A JOINT OR MEMBER CAN BE IDENTIFIED. STAMPS, IF USED, SHALL BE THE LOW-STRESS TYPE.												
<b>INSPECTION TASKS DURING WELDING (TABLE N5.4-2)</b>												
CONTROL AND HANDLING OF WELDING CONSUMABLES												
* PACKAGING				•								
* EXPOSURE CONTROL				•								
NO WELDING OVER CRACKED TACK WELDS				•								
ENVIRONMENTAL CONDITIONS												
* WIND SPEED WITHIN LIMITS				•								
* PRECIPITATION AND TEMPERATURE				•								
WPS FOLLOWED												
* SETTINGS ON WELDING EQUIPMENT				•								
* TRAVEL SPEED				•								
* SELECTED WELDING MATERIALS				•								
* SHIELDING GAS TYPE / FLOW RATE				•								
* PREHEAT APPLIED				•								
* INTERPASS TEMPERATURE MAINTAINED (MIN. / MAX)				•								
* PROPER POSITION (F, V, H, OH)				•								
WELDING TECHNIQUES												
* INTERPASS AND FINAL CLEANING				•								
* EACH PASS WITHIN PROFILE LIMITATIONS				•								
* EACH PASS MEETS QUALITY REQUIREMENTS				•								
PLACEMENT AND INSTALLATION OF STEEL HEADED STUD ANCHORS				•								
<b>INSPECTION TASKS AFTER WELDING (TABLE N5.4-3)</b>												
WELDS CLEANED				•								
SIZE, LENGTH AND LOCATION OF WELDS				•								
WELDS MEET VISUAL ACCEPTANCE CRITERIA				•								
* CRACK PROHIBITION				•								
* WELD / BASE-METAL FUSION				•								
* CRATER CROSS SECTION				•								
* WELD PROFILES				•								
* WELD SIZE				•								
* UNDERCUT				•								
* POROSITY				•								
ARC STRIKES				•								
K-AREA <sup>1</sup>				•								
WELD ACCESS HOLES IN ROLLED HEAVY SHAPES AND BUILT-UP HEAVY SHAPES <sup>2</sup>				•								
BACKING REMOVED AND WELD TABS REMOVED (IF REQUIRED)				•								
REPAIR ACTIVITIES				•								
DOCUMENT ACCEPTANCE OR REJECTION OF WELDED JOINT OR MEMBER				•								
NO PROHIBITED WELDS HAVE BEEN ADDED WITHOUT THE APPROVAL OF THE EOR				•								
<sup>1</sup> WHEN WELDING OF DOUBLER PLATES, CONTINUITY PLATES OR STIFFENERS HAS BEEN PERFORMED IN THE K-AREA, VISUALLY INSPECT THE WEB K-AREA FOR CRACKS WITHIN 3 IN. (75mm) OF THE WELD. <sup>2</sup> AFTER ROLLED HEAVY SHAPES (SEE SECTION A3.1c) AND BUILT-UP HEAVY SHAPES (SEE SECTION A3.1d) ARE WELDED, VISUALLY INSPECT THE WELD ACCESS HOLE FOR CRACKS.												

IF SHEET IS LESS THAN 22" x 34"  
IT IS A REDUCED PRINT.  
REDUCE SCALE ACCORDINGLY

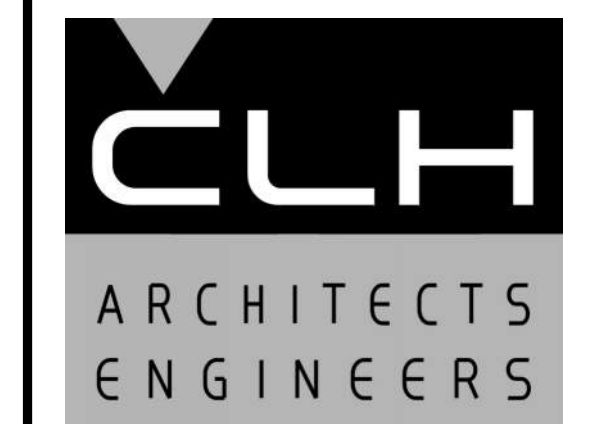

Case, Lowe & Hart, Inc. • 2484 Washington Blvd.  
Suite 510 • Ogden, Utah • 84401  
801.399.5821 • www.clhae.com

CONSULTANTS

STAMP



New Canopy  
3801 Washington Blvd.  
South Ogden, Utah

MARK	DATE	DESCRIPTION

ISSUE DATE: October 21, 2019  
PROJECT NO: 19060  
CAD DWG FILE:  
DRAWN BY: Z. Thorne  
CHK'D BY: S. Vanderdoes

REVIEW SET  
October 21, 2019

SHEET TITLE

SCHEDULES

SHEET NO:

S004

X:\DRAWINGS 2019\19394 - Big Lots Canopy\19394 - Big Lots Canopy - v1.19.rvt

10/24/2019 9:41:12 AM



SPECIAL INSPECTION SCHEDULE 1, 2				
ESTABLISHED PER 2018 IBC SECTION 110 AND CHAPTER 17				
ITEM	CONTINUOUS <sup>3</sup>	PERIODIC <sup>3</sup>	REFERENCE	COMMENTS
<b>PRE-FAB CONSTRUCTION (IBC 1704.2)</b>			REFERENCE NOTES P1 & P2	P1. SPECIAL INSPECTION IS NOT REQUIRED WHERE THE WORK IS DONE ON THE PREMISES OF A FABRICATOR REGISTERED AND APPROVED TO PERFORM SUCH WORK WITHOUT SPECIAL INSPECTION, PROVIDED THE FABRICATOR COMPLIES WITH IBC. INSPECTION FOR PREFABRICATED CONSTRUCTION SHALL BE THE SAME AS IF THE MATERIAL USED IN THE CONSTRUCTION TOOK PLACE ON SITE. SPECIAL INSPECTION WILL NOT BE REQUIRED DURING PREFABRICATION IF THE APPROVED AGENCY CERTIFIES THE CONSTRUCTION AND FURNISHES EVIDENCE OF COMPLIANCE. (SEE NOTE 2). P2.
<b>CONCRETE CONSTRUCTION (IBC 1705.3)</b>			SEE IBC TABLE 1705.3 - REF. NOTE C1	C1. SPECIAL INSPECTION IS NOT REQUIRED FOR CONC. ISOLATED SPREAD FOOTINGS, CONTINUOUS FOOTINGS, NON-STRUCTURAL SLABS, FOUNDATION WALLS, PATIOS, DRIVEWAYS, AND SIDEWALKS PROVIDED THE REQUIREMENTS OF IBC 1705.3 ARE MET. PERIODIC SPECIAL INSPECTION IS ALLOWED FOR VERIFICATION OF THE WELDABILITY OF REINFORCING STEEL RESISTING FLEXURAL AND AXIAL FORCES IN INTERMEDIATE AND SPECIAL MOMENT FRAMES, BOUNDARY ELEMENTS OF SPECIAL REINFORCED CONCRETE SHEAR WALLS, AND SHEAR REINFORCEMENT. PERIODIC SPECIAL INSPECTION IS ALLOWED FOR WELDING OF OTHER ASTM A 706 REINFORCING STEEL NOT INCLUDED IN THE CONTINUOUS SPECIAL INSPECTION REQUIREMENTS NOTED ABOVE. C2. PERFORM AIR, SLUMP AND TEMP. TESTS WHEN CONCRETE SAMPLES ARE CAST. C3. PERIODIC SPECIAL INSPECTION IS REQUIRED FOR VERIFICATION OF IN-SITU CONCRETE STRENGTH FOR POST-TENSIONED CONCRETE PRIOR TO TENSIONING TENDONS OR REMOVING SHORING OR FORMS. C4. EPOXY AND EXPANSION ANCHORS INTO MASONRY OR CONCRETE MAY BE USED ONLY WHEN APPROVED BY ARCHITECT, AND/OR ENGINEER USING AN APPROVED PRODUCT WITH CURRENT PUBLISHED ICC RESEARCH REPORT NUMBERS. COORDINATE CONTINUOUS/PERIODIC SPECIAL INSPECTION REQUIREMENTS WITH ICC REPORT. C5.
REINFORCING STEEL PLACEMENT		●		
WELDING OF REINFORCING STEEL	●	●	REFERENCE NOTE C2	
EMBEDDED BOLTS & PLATES	●			
VERIFYING REQUIRED DESIGN MIX		●		
CONCRETE PLACEMENT / SAMPLING	●		REFERENCE NOTE C3	
CURING TEMPERATURE / TECHNIQUES		●		
PRESTRESSED CONCRETE				
APPLICATION OF PRESTRESSING FORCES	●			
GROUTING BONDED TENDONS	●		IN SEISMIC-FORCE-RESISTING SYSTEM	
ERECTION OF PRECAST MEMBERS		●		
VERIFICATION OF IN-SITU STRENGTH		●	REFERENCE NOTE C4	
EPOXY / EXPANSION ANCHOR PLACEMENT	●	●	REFERENCE NOTE C5	
<b>SOILS (IBC 1705.6)</b>			REFERENCE NOTE F1	F1. SPECIAL INSPECTION OF SOILS SHALL REFERENCE THE APPROVED SOILS REPORT TO DETERMINE COMPLIANCE. F2. WHERE SOILS REPORT IS NOT PROVIDED SPECIAL INSPECTIONS ARE REQUIRED TO VERIFY THAT THE IN-PLACE DRY DENSITY OF THE COMPACTED FILL IS NOT LESS THAN 90 PERCENT OF THE MAXIMUM DRY DENSITY AT OPTIMUM MOISTURE CONTENT DETERMINED IN ACCORDANCE WITH ASTM D 1557.
VERIFY ADEQUATE MATERIALS BELOW FOOTINGS		●	REFERENCE NOTE F1	
EXCAVATIONS EXTEND TO PROPER DEPTH AND REACH PROPER MATERIAL		●	REFERENCE NOTE F2	
CLASSIFY & TEST CONTROLLED FILL MATERIALS		●	REFERENCE NOTE F2	
PERFORM MATERIALS, DENSITIES, AND LIFT THICKNESSES DURING PLACEMENT AND COMPACTION OF CONTROLLED FILL.	●		REFERENCE NOTE F1	
PROPERLY PREPARED SITE AND SUB-GRADE PRIOR TO FILL.		●	REFERENCE NOTE F1	

**GENERAL SPECIAL INSPECTION NOTES :**

- THE ITEMS MARKED WITH A "●" IN THE SPECIAL INSPECTION SCHEDULE SHALL BE INSPECTED IN ACCORDANCE WITH IBC CHAPTER 17 BY A CERTIFIED SPECIAL INSPECTOR FROM AN ESTABLISHED TESTING AGENCY. FOR MATERIAL SAMPLING AND TESTING REQUIREMENTS, REFER TO THE MATERIAL SAMPLING AND TESTING SECTION, THE PROJECT SPECIFICATIONS, AND THE SPECIFIC GENERAL NOTES SECTIONS. THE TESTING AGENCY SHALL SEND COPIES OF ALL STRUCTURAL TESTING AND INSPECTION REPORTS DIRECTLY TO THE ARCHITECT, ENGINEER, CONTRACTOR, AND BUILDING OFFICIAL. ANY ITEMS WHICH FAIL TO COMPLY WITH THE APPROVED CONSTRUCTION DOCUMENTS SHALL IMMEDIATELY BE BROUGHT TO THE ATTENTION OF THE CONTRACTOR FOR CORRECTION. IF DISCREPANCIES ARE NOT CORRECTED, THEY SHALL BE BROUGHT TO THE ATTENTION OF THE BUILDING OFFICIAL, ARCHITECT, AND ENGINEER PRIOR TO COMPLETION OF THAT PHASE OF WORK. SPECIAL INSPECTION TESTING REQUIREMENTS APPLY EQUALLY TO ALL BIDDER DESIGNED COMPONENTS.
- ANY CONSTRUCTION OR MATERIAL THAT HAS FAILED INSPECTION SHALL BE SUBJECT TO REMOVAL AND REPLACEMENT.
- CONTINUOUS SPECIAL INSPECTION MEANS THE FULL-TIME OBSERVATION OF WORK REQUIRING SPECIAL INSPECTION BY AN APPROVED SPECIAL INSPECTOR WHO IS PRESENT IN THE AREA WHERE THE WORK IS BEING PERFORMED. PERIODIC SPECIAL INSPECTION MEANS THE PART-TIME OR INTERMITTENT OBSERVATION OF WORK REQUIRING SPECIAL INSPECTION BY AN APPROVED SPECIAL INSPECTOR WHO IS PRESENT IN THE AREA WHERE THE WORK HAS BEEN OR IS BEING PERFORMED AND AT THE COMPLETION OF THE WORK. (IBC SECTION 202)

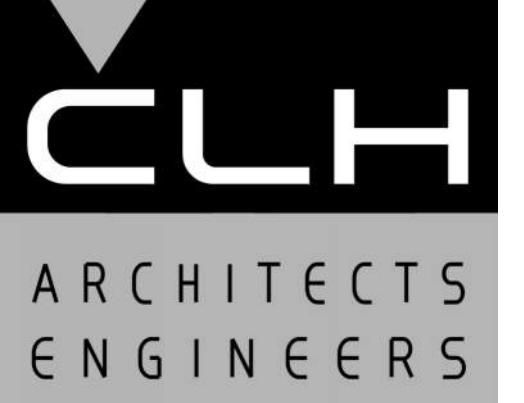

Case, Lowe & Hart, Inc. • 2484 Washington Blvd.  
Suite 510 • Ogden, Utah • 84401  
801.399.5821 • www.clhac.com

CONSULTANTS

STAMP



New Canopy

3801 Washington Blvd.  
South Ogden, Utah

MARK	DATE	DESCRIPTION

ISSUE DATE: October 21, 2019  
PROJECT NO: 19060  
CAD DWG FILE:  
DRAWN BY: Z. Thorne  
CHK'D BY: S. Vanderdoes

REVIEW SET  
October 21, 2019

SHEET TITLE

SCHEDULES

SHEET NO:

S005

X:\DRAWINGS 2019\19394 - Big Lots Canopy\S-19394 - Big Lots Canopy - v1.19.rvt  
10/24/2019 9:41:13 AM

IF SHEET IS LESS THAN 22"x 34"  
IT IS A REDUCED PRINT.  
REDUCE SCALE ACCORDINGLY



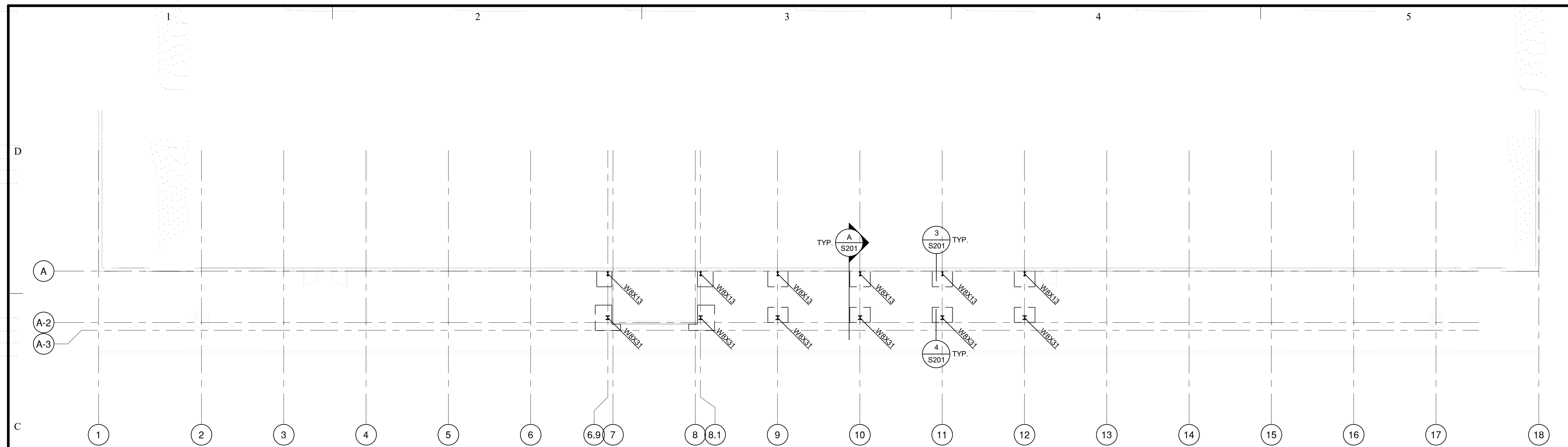

FOOTING AND FOUNDATION PLAN

SCALE: 3/32" = 1'-0"

A  
S101

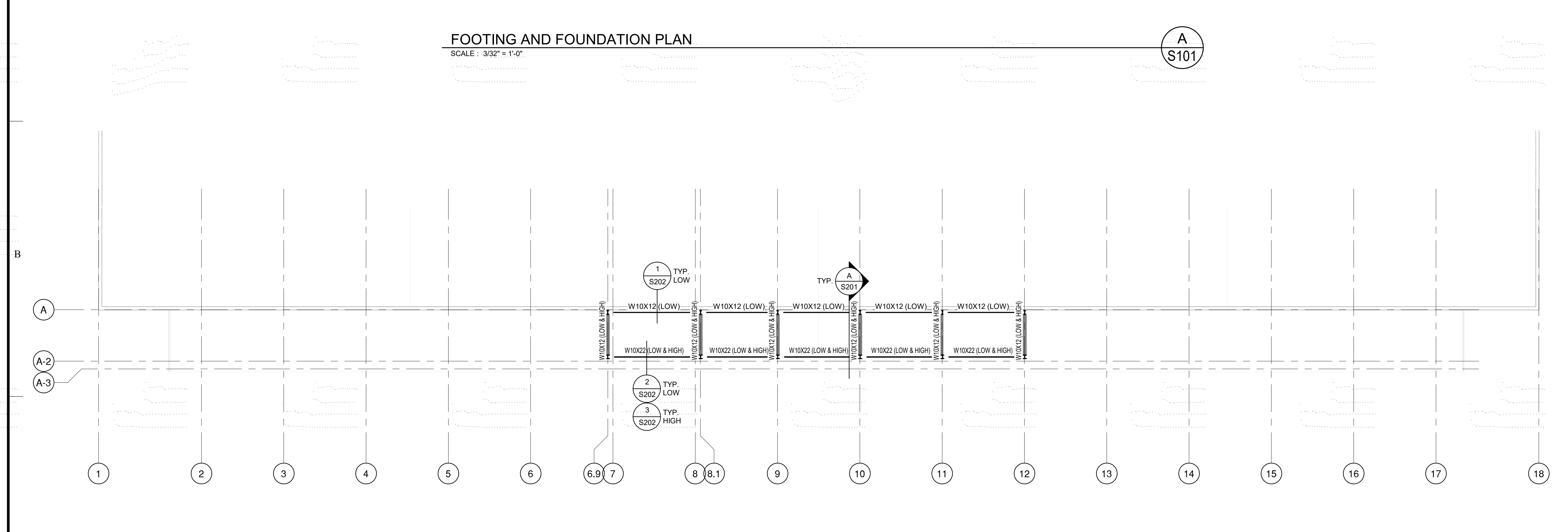

CANOPY FRAMING PLAN

SCALE: 3/32" = 1'-0"

B  
S101

NOTE: DUE TO A LACK OF AS-BUILT DRAWINGS AND SELECTIVE DEMOLITION, EXISTING CONDITIONS HAVE NOT BEEN VERIFIED. CONTRACTOR TO FIELD VERIFY ALL EXISTING CONDITIONS AND CONTACT ARCHITECT AND ENGINEER IF EXISTING CONDITIONS VARY FROM THOSE SHOWN.

IF SHEET IS LESS THAN 22"x 34"  
IT IS A REDUCED PRINT.  
REDUCE SCALE ACCORDINGLY

X:\DRAWINGS 2019\19394 - Big Lots Canopy\19394 - Big Lots Canopy - v1.19.rvt

10/24/2019 9:41:17 AM



MARK	DATE	DESCRIPTION

ISSUE DATE:	October 21, 2019
PROJECT NO:	19060
CAD DWG FILE:	
DRAWN BY:	Z. Thormer
CHK'D BY:	S. Vanderdoes

REVIEW SET
October 21, 2019
SHEET TITLE
DETAILS

SHEET NO:	S201
-----------	------

BASE PLATE SCHEDULE				
COLUMN SIZE	BASE PLATE SIZE	DIMENSION 'A'	DIMENSION 'B'	A.B. SIZE
W8x13	3/4" x 6" x 0'-10"	2"	1 1/2"	3/4"
W8x31	3/4" x 10" x 0'-10"	2"	3"	3/4"

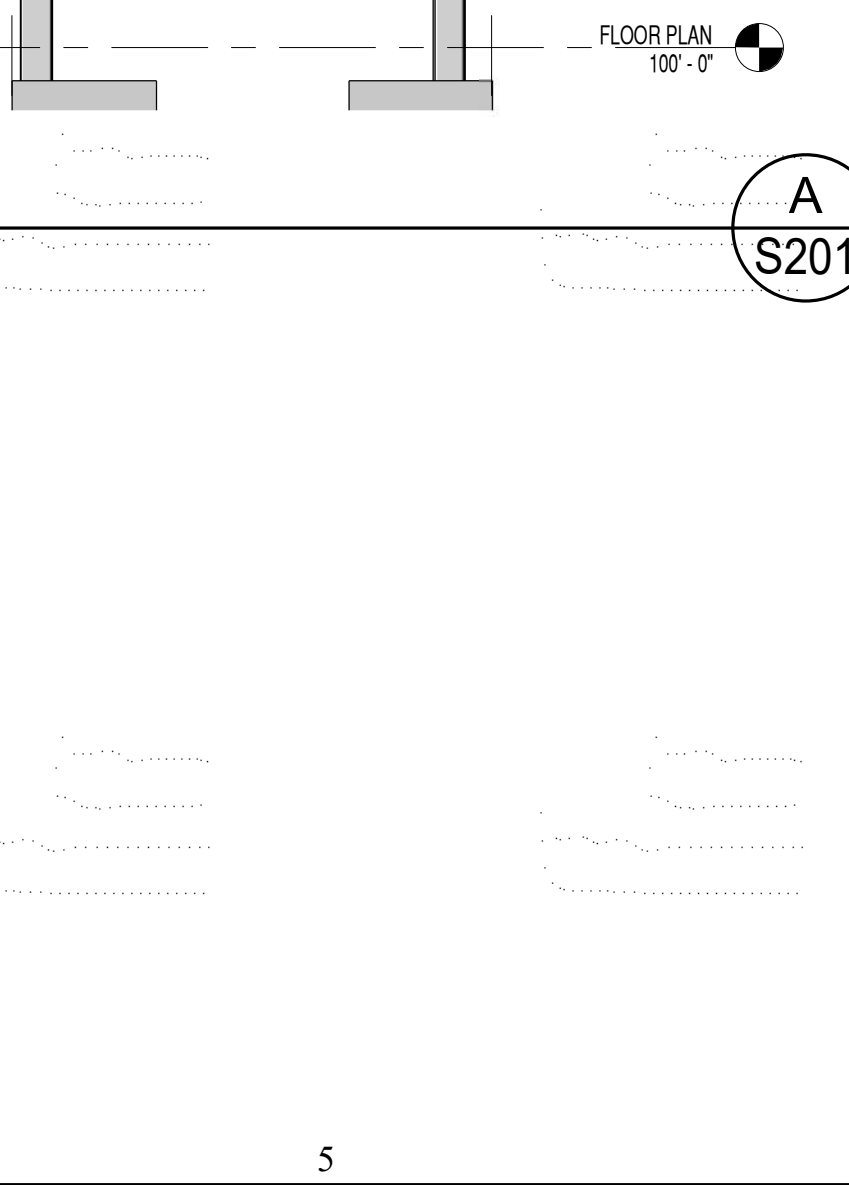
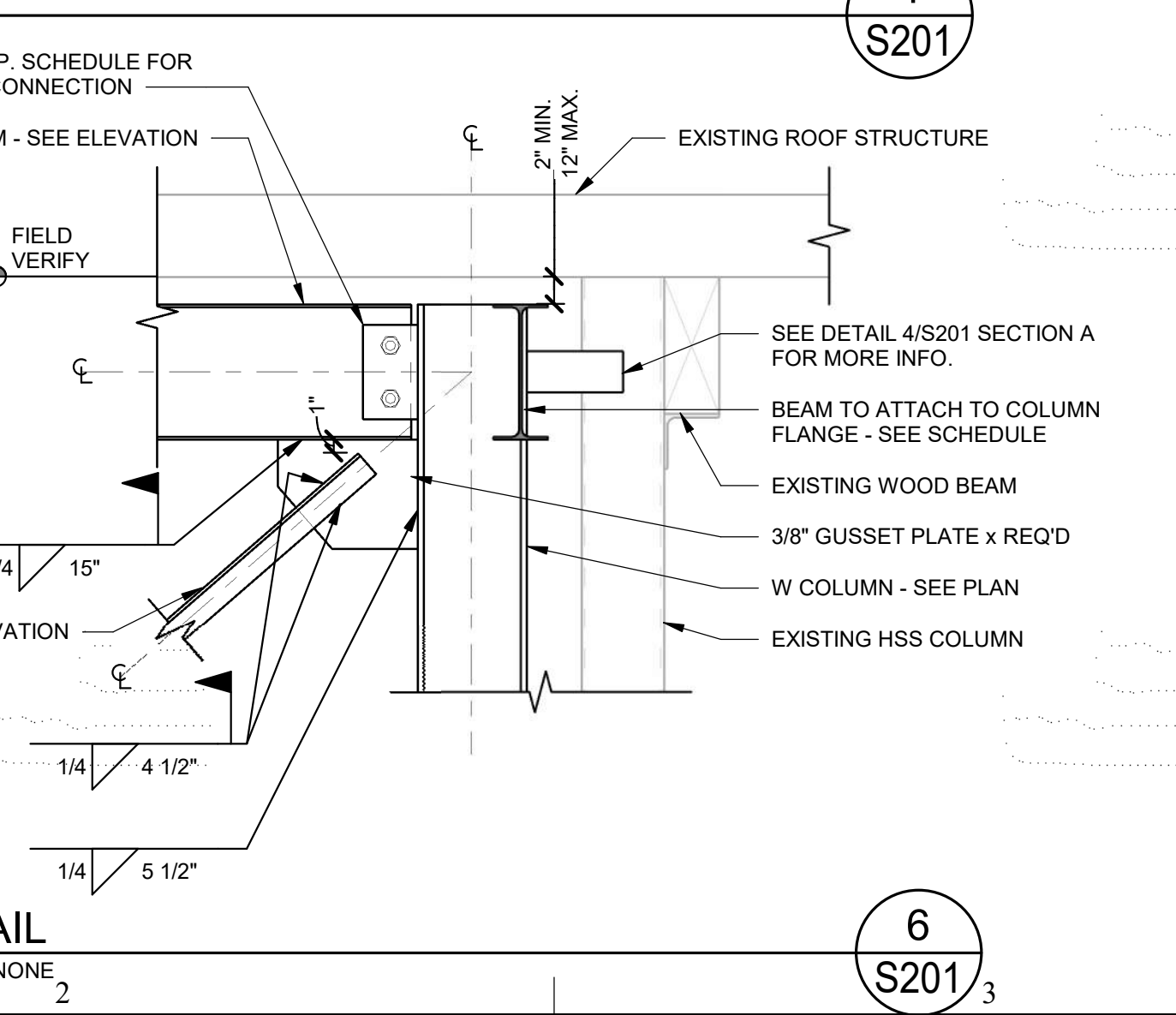
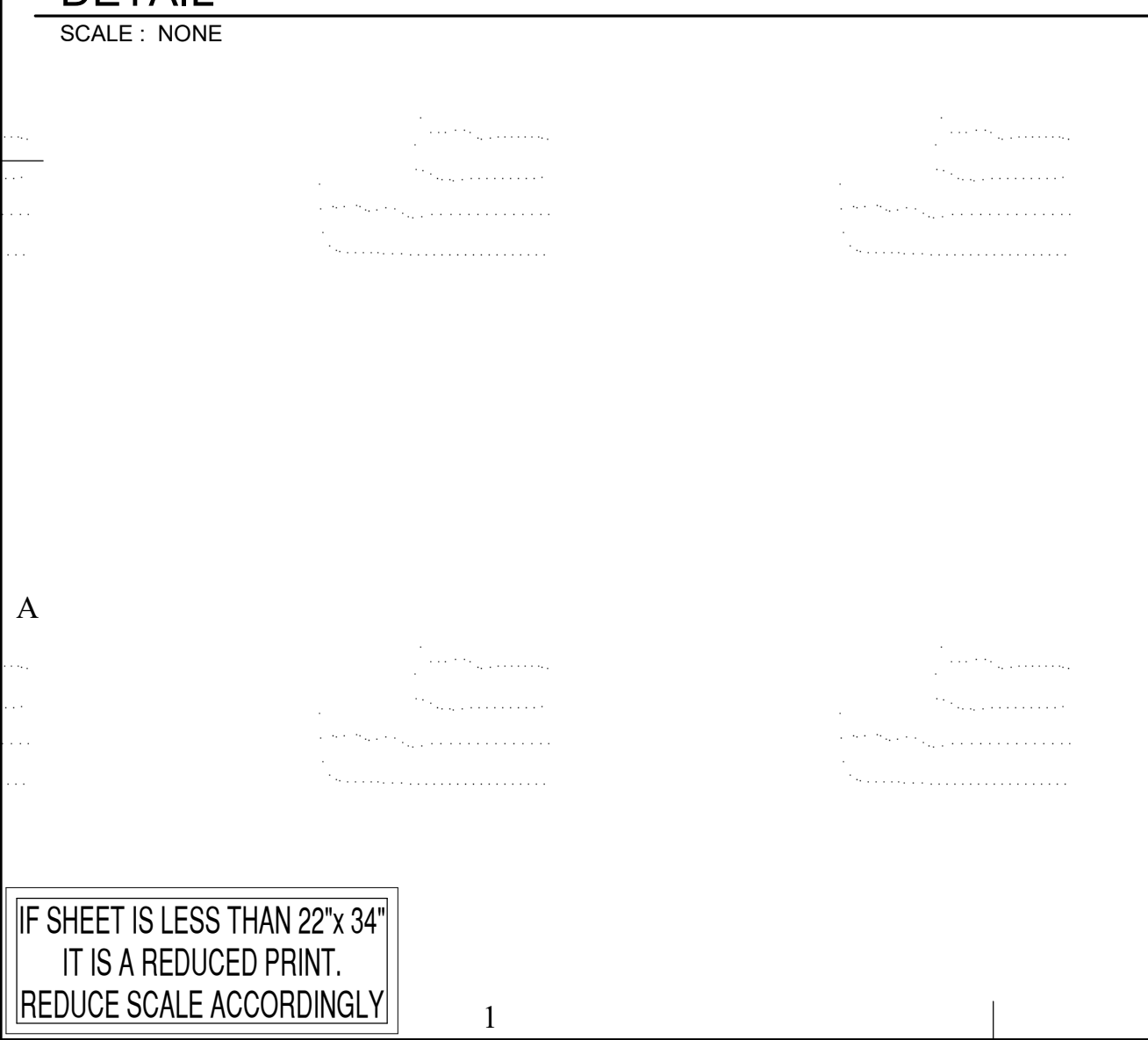
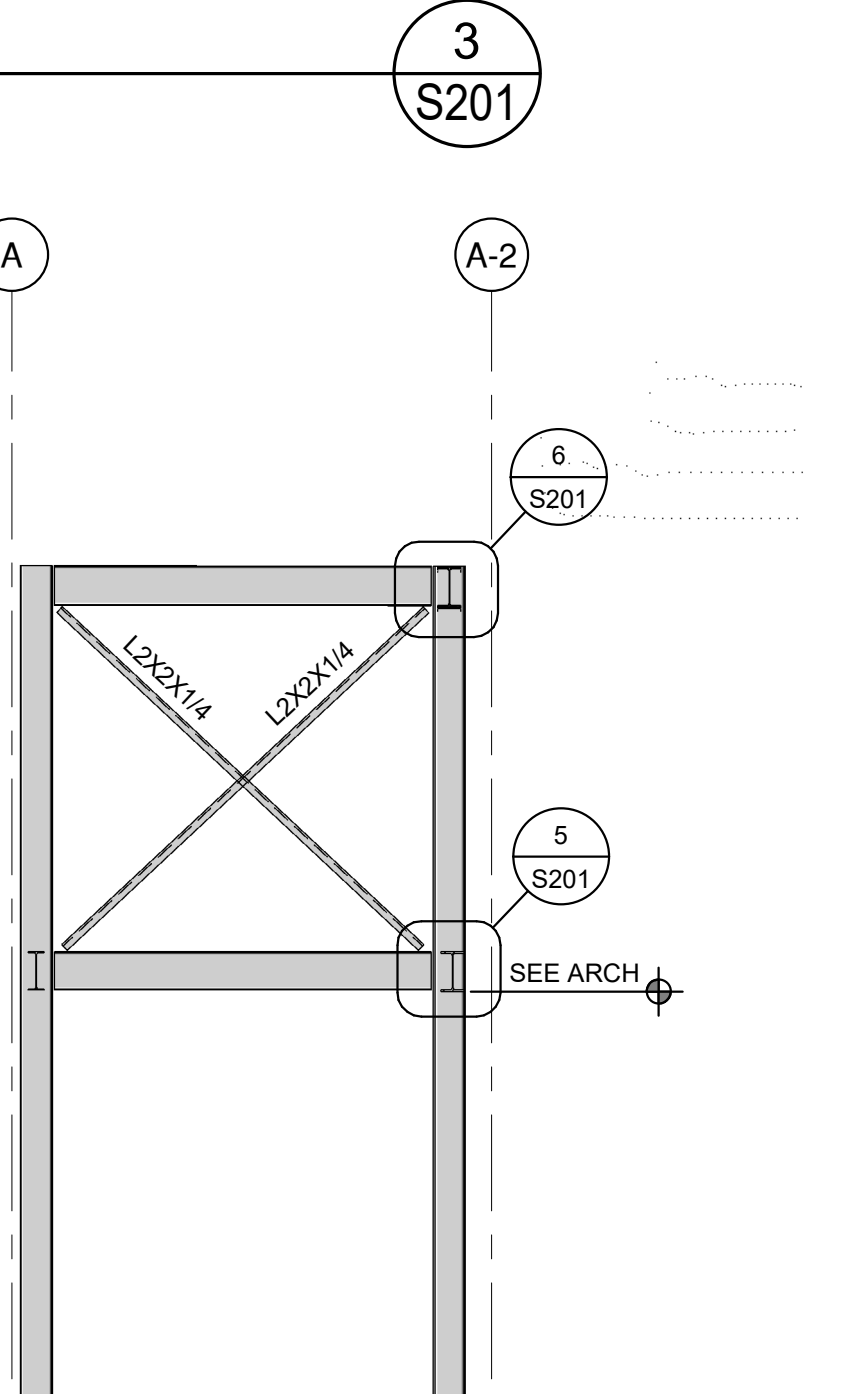
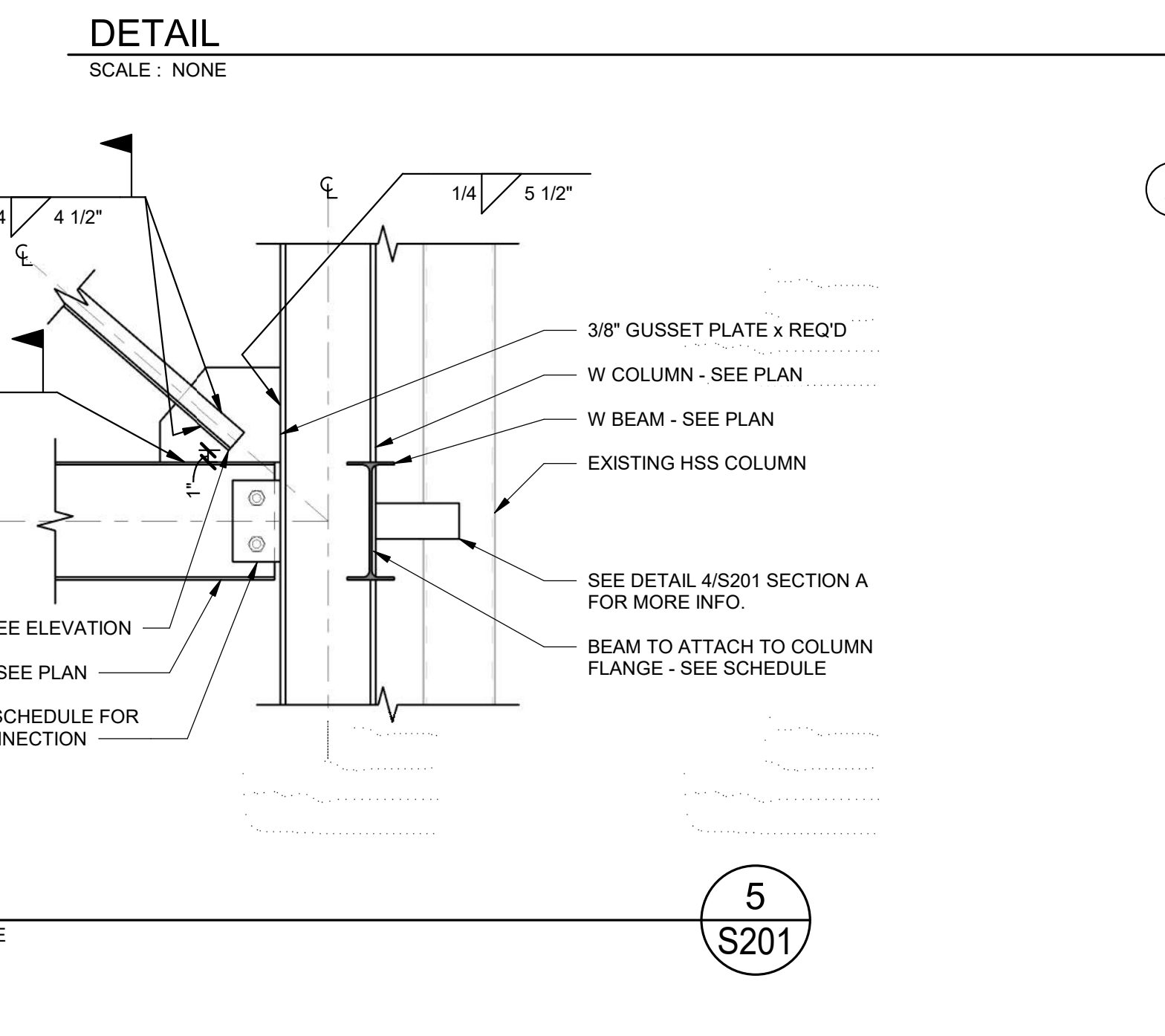
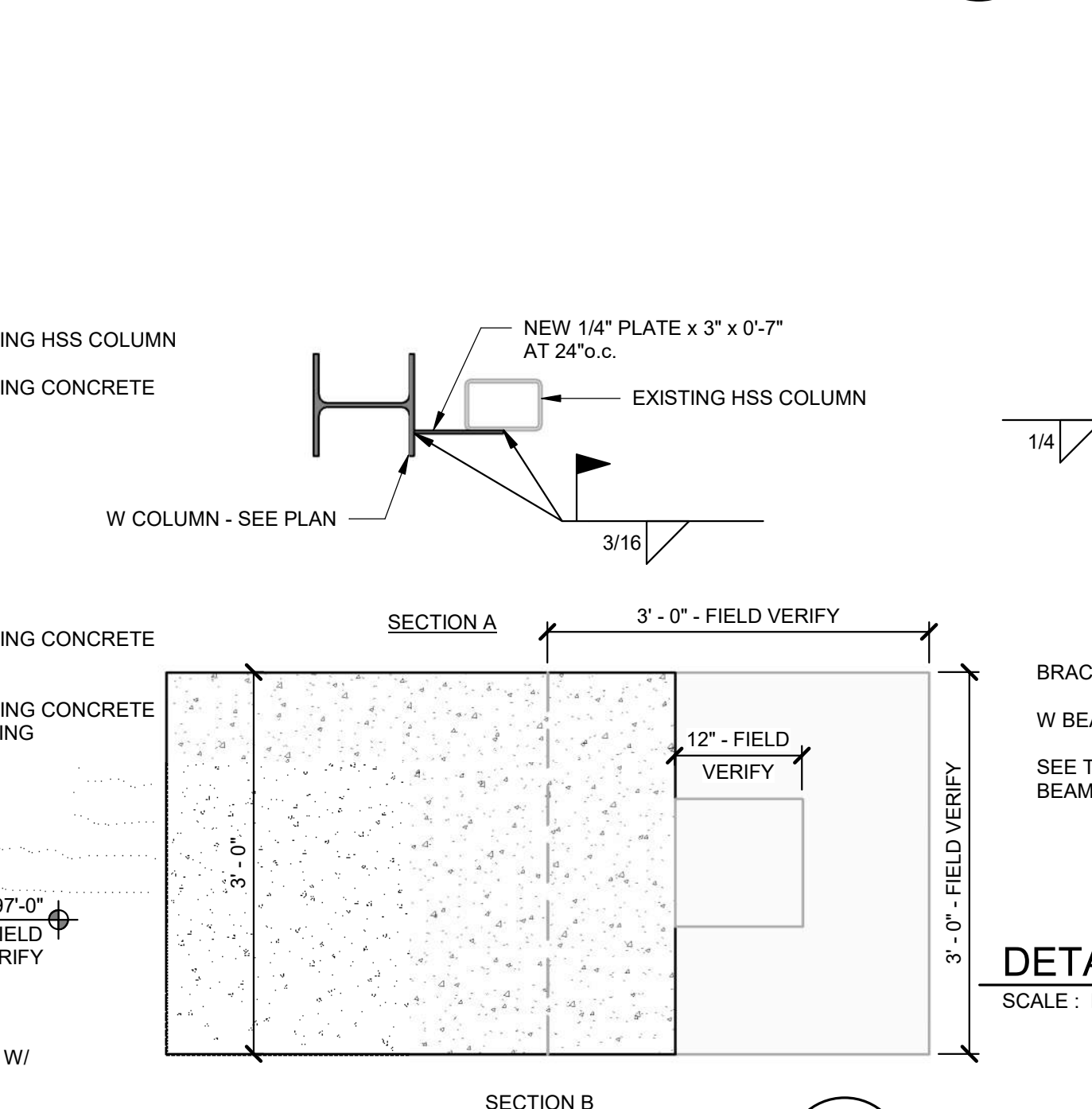
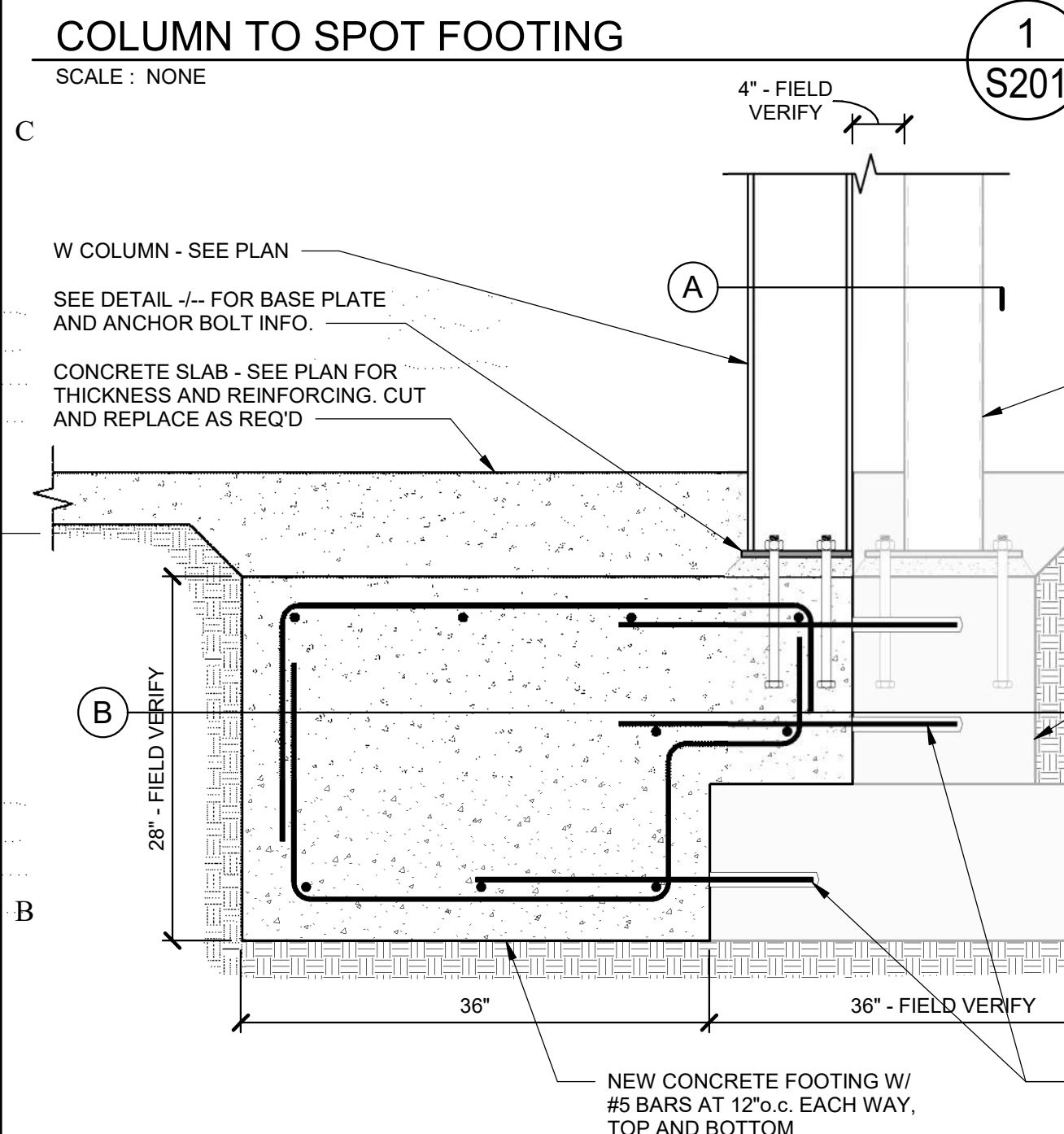
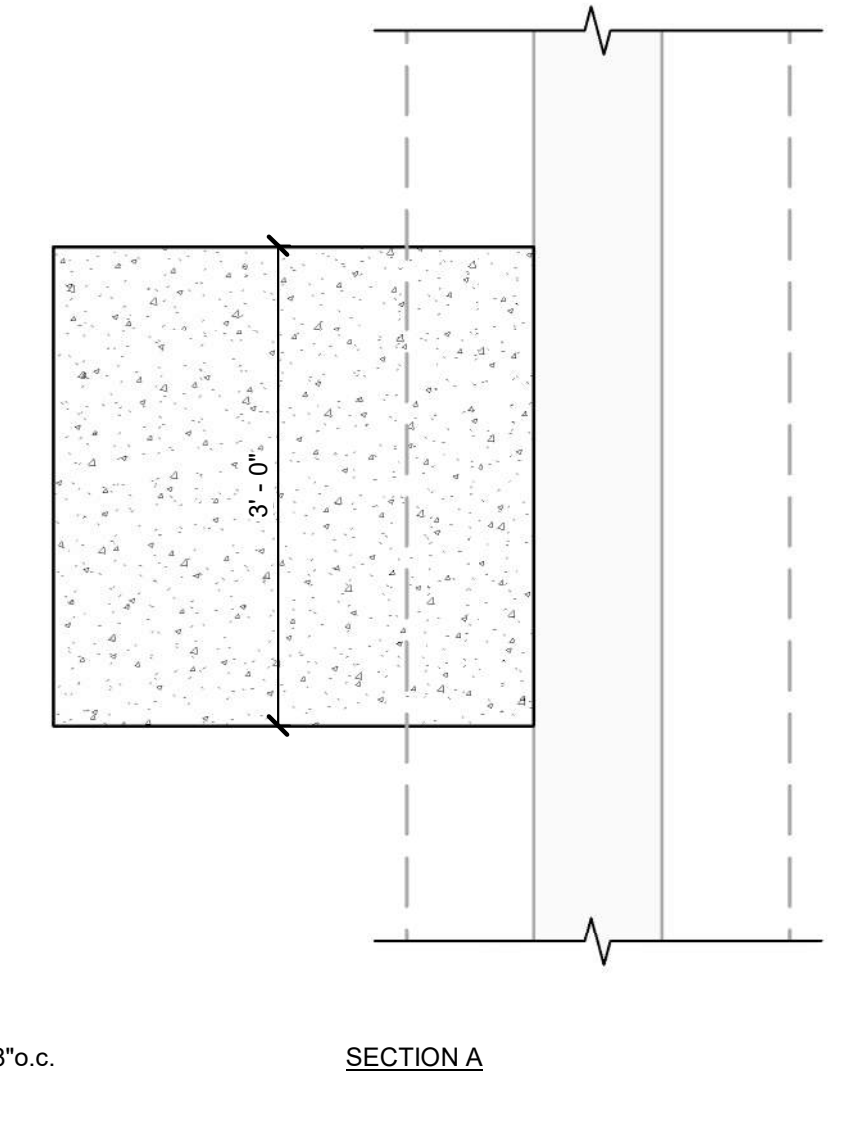
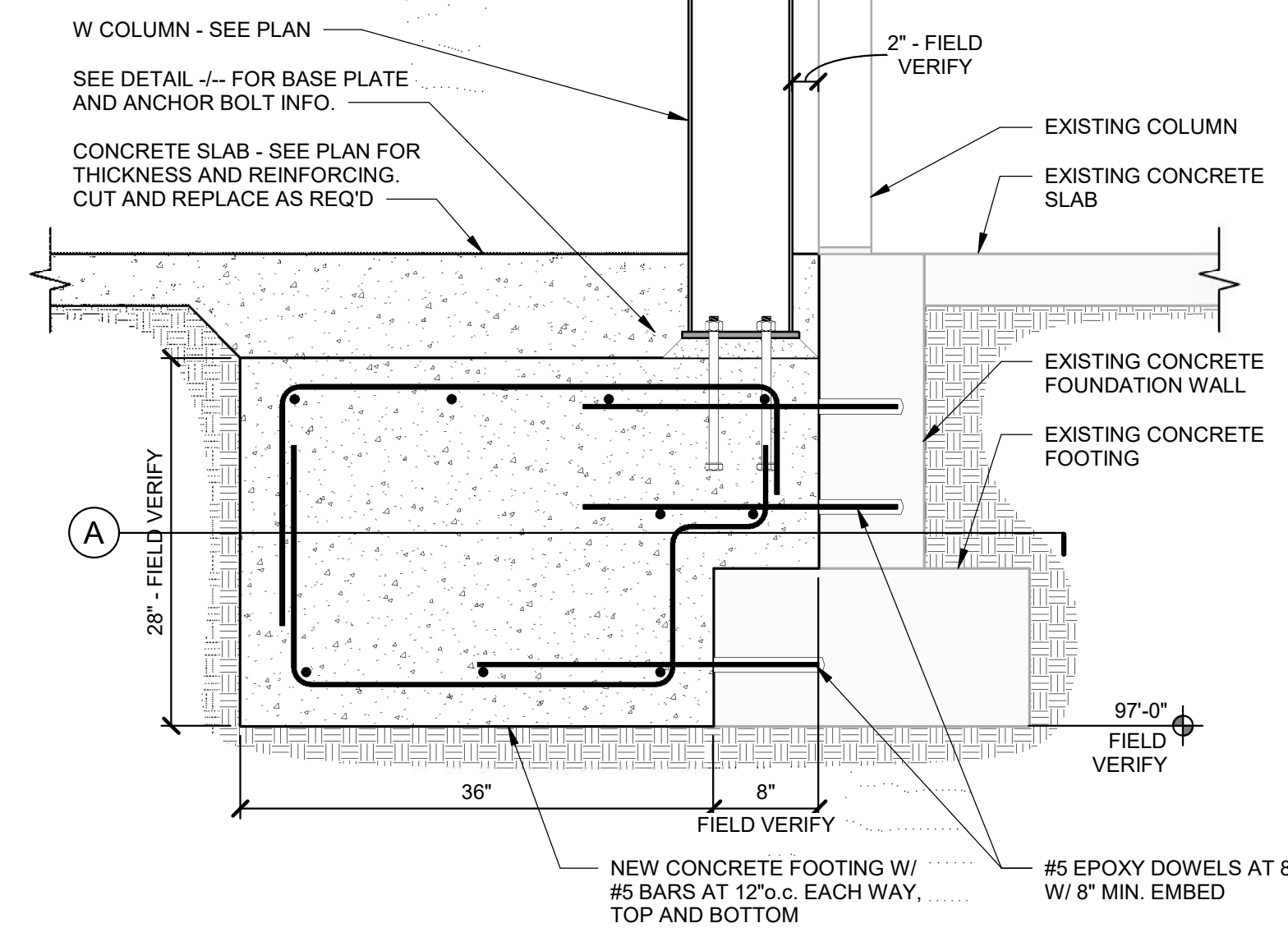
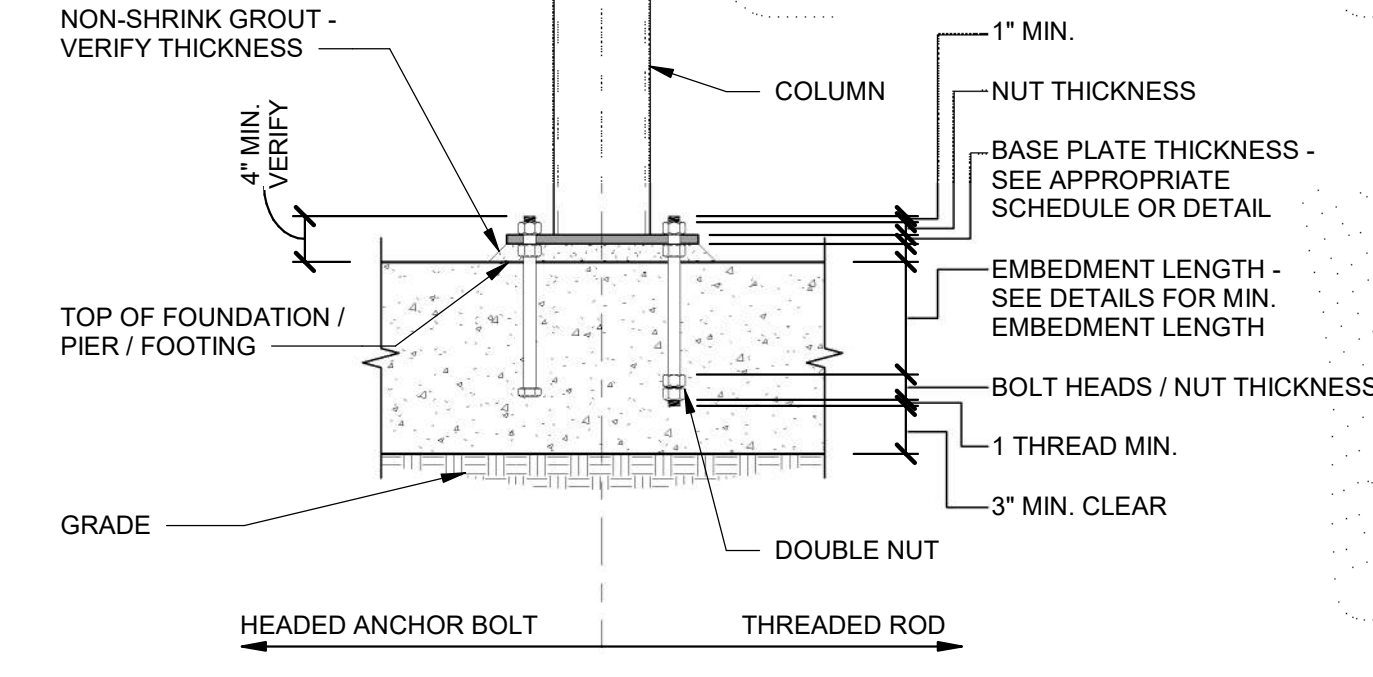
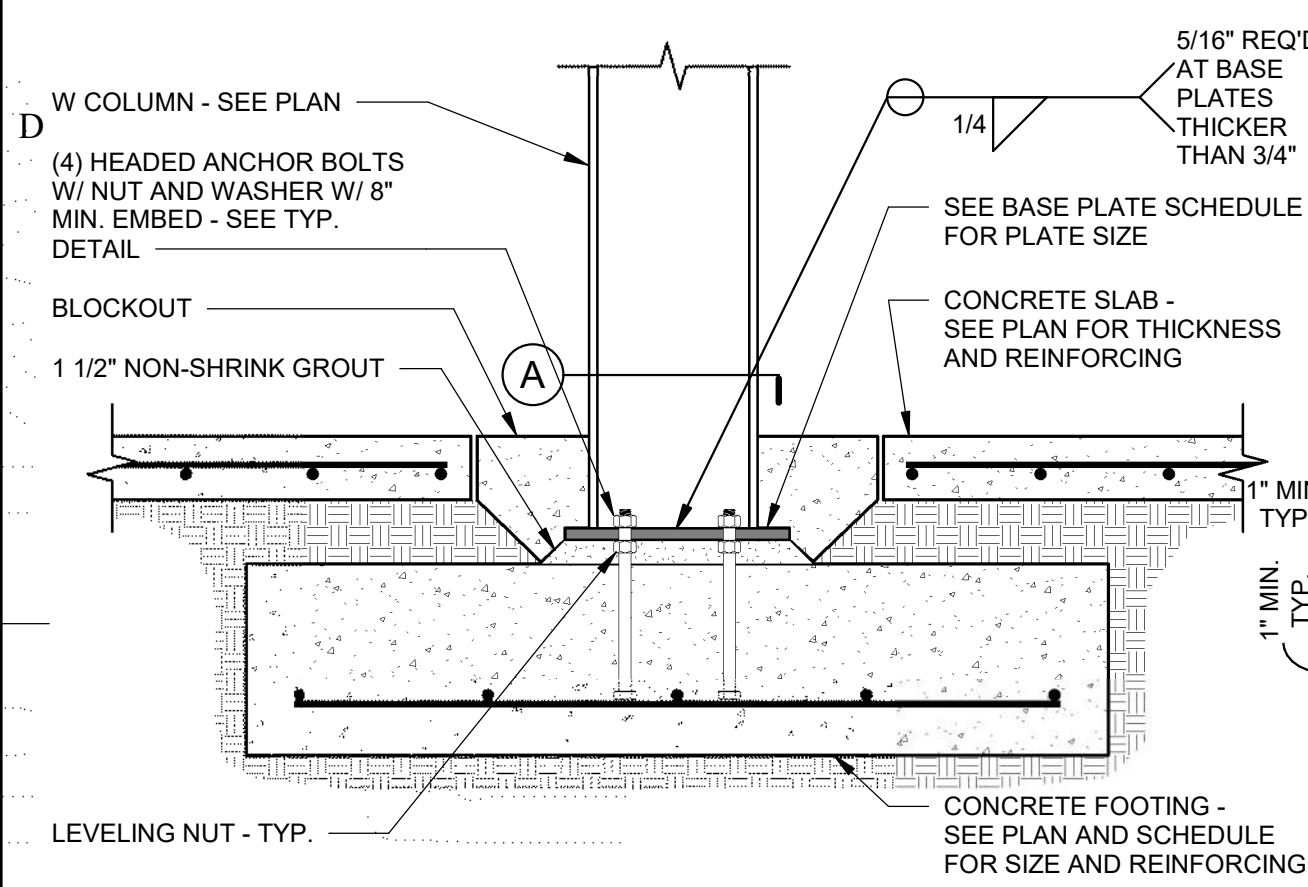

IF SHEET IS LESS THAN 22" x 34"  
IT IS A REDUCED PRINT.  
REDUCE SCALE ACCORDINGLY

X:\DRAWINGS 2019\19394 - Big Lots Canopy - v1.19.rvt  
10/24/2019 9:41:19 AM  
© COPYRIGHT - CASE, LOWE & HART, INC. ALL RIGHTS RESERVED



CONSULTANTS

STAMP



New Canopy

3801 Washington Blvd.  
South Ogden, Utah

MARK	DATE	DESCRIPTION

ISSUE DATE:	October 21, 2019
PROJECT NO:	19060
CAD DWG FILE:	
DRAWN BY:	Author
CHK'D BY:	Checker

REVIEW SET

October 21, 2019

SHEET TITLE

DETAILS

SHEET NO:

S202

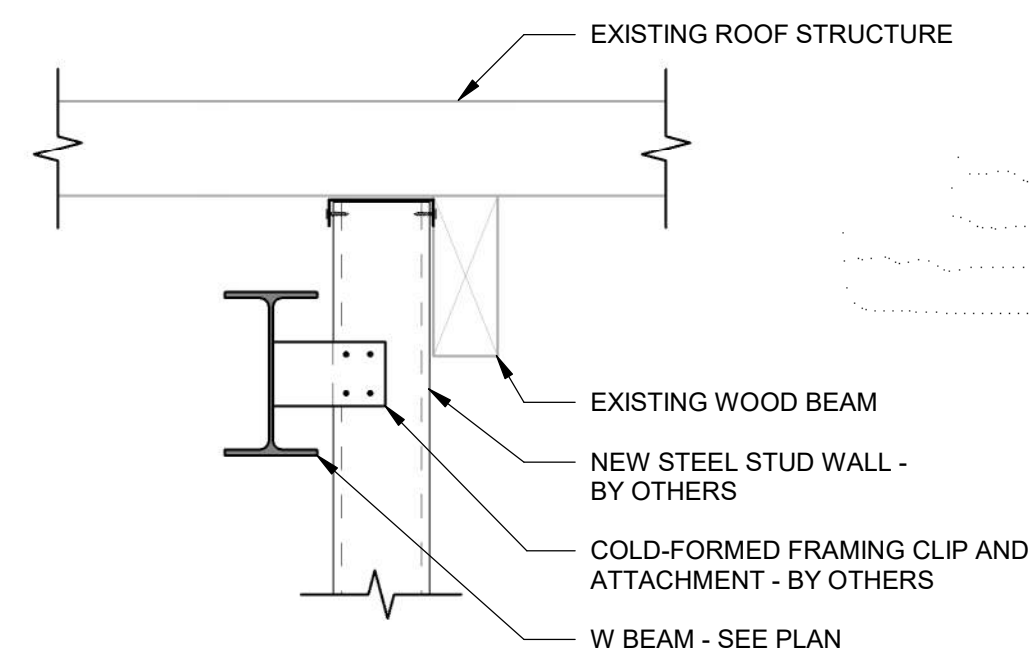
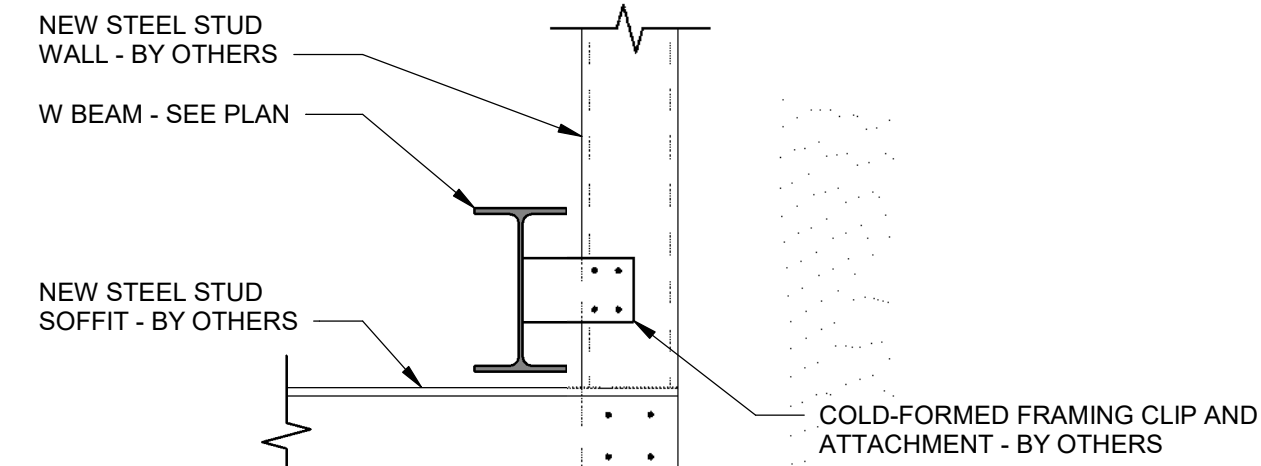
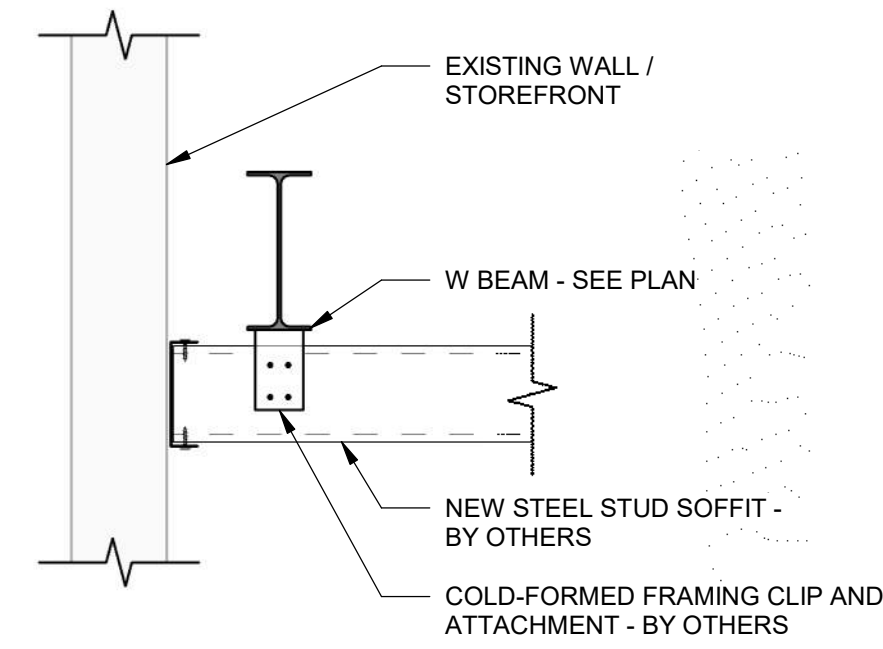

DETAIL

SCALE: NONE

1

S202

DETAIL

SCALE: NONE

2

S202

DETAIL

SCALE: NONE

3

S202

X:\DRAWINGS\2019\19394 - Big Lots Canopy\S-19394 - Big Lots Canopy - v1.0.rvt

10/24/2019 9:41:21 AM

IF SHEET IS LESS THAN 22" x 34"  
IT IS A REDUCED PRINT.  
REDUCE SCALE ACCORDINGLY



**ARCHITECTURAL NOTES**

- THE ARCHITECTURAL DRAWINGS ARE THE PRIMARY CONTRACT DOCUMENTS. ANY CONFLICTS BETWEEN ARCHITECTURAL DRAWINGS AND EXISTING CONDITIONS AND/OR DRAWINGS OF OTHER DISCIPLINES SHALL BE IMMEDIATELY REPORTED TO THE ARCHITECT.
- THE CONTRACTOR SHALL VERIFY ALL EXISTING CONDITIONS PRIOR TO ANY WORK. ITEMS AND DIMENSIONS BETWEEN EXISTING AND NEW PORTIONS OF THE PROJECT SHALL BE VERIFIED TO ENSURE COORDINATION.
- THE CONTRACTOR SHALL SUBMIT ANY PROPOSED CHANGES OR MODIFICATIONS OF THE CONTRACT DOCUMENTS, IN WRITING, TO THE ARCHITECT BEFORE PROCEEDING WITH ANY ACTION.
- WHERE SPECIFIC DETAILS ARE NOT PROVIDED, TYPICAL OR SIMILAR INDUSTRY STANDARD DETAILS SHALL APPLY. IF FURTHER DETAIL IS REQUIRED CONTACT ARCHITECT.
- DETAILS ARE PROVIDED FOR VISUAL REPRESENTATION OF DESIGN INTENT. OFTEN THE DETAILS ARE BASED ON A BASIS-OF-DESIGN PRODUCT AND/OR MATERIAL AND MAY BE DIAGRAMMATIC IN NATURE.
- IF A DIFFERENT PRODUCT OR MATERIAL FROM THAT INDICATED ON THE DRAWINGS OR SPECIFICATIONS IS SUBSTITUTED, IT IS THE RESPONSIBILITY OF THE CONTRACTOR TO PROVIDE ALTERNATE DETAILS AS REQUIRED FOR THE ARCHITECT TO REVIEW.
- GENERALLY, DIMENSIONS SHOWN OF ARCHITECTURAL DRAWINGS ARE TAKEN FROM THE CORE STRUCTURE FACE (IE. CONCRETE WALL=FACE OF WALL; STUD WALL=FACE OF STUD).
- ANY ADDITIONAL BLOCKING, BRACING, TRIM, FLASHING, SEALANTS, ETC. REQUIRED FOR INSTALLATION OF COMPLETE SYSTEMS PERTAINING TO DOORS, WINDOWS, OPENINGS, PENETRATIONS, ETC. ARE EXPECTED TO BE PROVIDED AND INSTALLED BY THE CONTRACTOR.
- ASSUME ALL GYP. BD. WALLS TO HAVE TOPSET RUBBER BASE INSTALLED UNLESS NOTED OTHERWISE.
- PROVIDE SEALANT OR TRIM AS APPROPRIATE WHERE DISSIMILAR MATERIALS COME IN CONTACT.
- PROVIDE FLOORING TRANSITION WHERE DISSIMILAR FLOORING MATERIALS OCCUR.
- PAINT ALL MISCELLANEOUS SURFACES, SUPPORTS, METALS, ETC. IF PERMANENTLY ATTACHED TO PAINTED SURFACE OR EXPOSED TO THE ELEMENTS.

SYMBOLS	
	VIEW TITLE
	GRAPHIC SCALE
	NORTH ARROW w/ TRUE NORTH
	GRID INDICATOR
	SECTION CALLOUT
	DETAIL CALLOUT
	DETAIL CALLOUT
	ELEVATION CALLOUT
	LEVEL / ELEVATION CALLOUT
	SPOT ELEVATION CALLOUT
	ROOF SLOPE INDICATOR
	ROOM TAG
	DOOR TAG
	WALL TAG
	WINDOW TAG
	DEMOLITION KEYNOTE
	FIRE RISER

ABBREVIATIONS			
& L @ #	AND ANGLE AT POUND OR NUMBER	JAN JST JT	JANITOR JOIST JOINT
AC	ACOUSTICAL	K.O.	KNOCK OUT
A.F.F.	ABOVE FINISH FLOOR	LAM	LAMINATE
ALUM	ALUMINUM	LAV	LAVATORY
APPROX	APPROXIMATE	MAX	MAXIMUM
ARCH	ARCHITECTURAL	MAS	MASONRY
ASPH	ASPHALT	MECH	MECHANICAL
BD	BOARD	MEMB	MEMBRANE
BITUM	BITUMINOUS	MTL	METAL
BLDG	BUILDING	MFR	MANUFACTURER
BLKG	BLOCKING	MH	MANHOLE
BRG	BEARING	MIN	MINIMUM
BTM	BOTTOM	MISC	MISCELLANEOUS
C	TOP OF FINISH CONCRETE	M.O.	MASONRY OPENING
C.I.	CAST IRON	MTD	MOUNTED
C.J.	CONTROL JOINT	N	NORTH
C.L.	CENTER LINE	N.I.C.	NOT IN CONTRACT
CLG	CEILING	NO or #	NUMBER
CLR	CLEAR	NOM	NOMINAL
C.M.U.	CONCRETE MASONRY UNIT	N.T.S.	NOT TO SCALE
C.O.	CLEAN OUT	O.C.	ON CENTER
C.O.T.G.	CLEAN OUT AT GRADE	O.D.	OUTSIDE DIAMETER (DIM)
COL	COLUMN	OFF	OFFICE
CONC	CONCRETE	OH	OVERHEAD
CONN	CONNECTION	OPNG	OPENING
CONSTR	CONSTRUCTION	OPP	OPPOSITE
CONT	CONTINUOUS	PL	PLATE
C.T.	CERAMIC TILE	PLAM	PLASTIC LAMINATE
CTR	CENTER	PLYWD	PLYWOOD
D.C.W.	DOMESTIC COLD WATER	P.O.C.	POINT OF CONNECTION
D.H.W.	DOMESTIC HOT WATER	PNL	PANEL
D.F.	DRINKING FOUNTAIN	PR	PAIR
DTL	DETAIL	PT	POINT
DIA	DIAMETER	Q.T.	QUARRY TILE
DIM	DIMENSION	RAD	RADIUS
DISP	DISPENSER	R.D.	ROOF DRAIN
DN	DOWN	REF	REFERENCE
DRN	DRAIN	REINF	REINFORCED
DS	DOWNSPOUT	REQD	REQUIRED
DWG	DRAWING	RESIL	RESILIENT
E	EAST	RFG	ROOFING
EA	EACH	RM	ROOM
E.I.F.S.	EXTERIOR INSULATION FINISH SYSTEM	RS	RESINOUS FLOORING
E.J.	EXPANSION JOINT	R.O.	ROUGH OPENING
EL	ELEVATION	S	SOUTH
ELEC	ELECTRICAL	SCH	SCHEDULE
ENGR	ENGINEER	SECT	SECTION
EQ	EQUAL	SHT	SHEET
EQUIP	EQUIPMENT	SIM	SIMILAR
EX	EXISTING	SPEC	SPECIFICATION
EXT	EXTERIOR	SQ	SQUARE
F.A.	FIRE ALARM	S.S.	SANITARY SEWER
F.D.	FLOOR DRAIN	S.ST	STAINLESS STEEL
FDN	FOUNDATION	STD	STANDARD
F.E.	FIRE EXTINGUISHER	STL	STEEL
F.E.C.	FIRE EXTINGUISHER CABINET	STOR	STORAGE
FIN	FINISH	STR	STRUCTURAL
FLR	FLOOR	SUSP	SUSPENDED
FLASH	FLASHING	SYM	SYMMETRICAL
FLUOR	FLUORESCENT	SYS	SYSTEM
F.O.	FACE OF	TLT	TOILET (ROOM)
F.R.	FIRE RATED	TRTD	TREATED (PRESERVATIVE)
FT	FOOR OR FEET	T & B	TOP & BOTTOM
FTG	FOOTING	T.O.	TOP OF
FUT	FUTURE	TRANS	TRANSFORMER
GA	GAUGE	TYP	TYPICAL
GALV	GALVANIZED	U.N.O.	UNLESS NOTED OTHERWISE
GND	GROUND	UT	URINAL
GR	GRADE	VERT	VERTICAL
G.W.B.	GYPSSUM WALL BOARD	VEST	VESTIBULE
GYP	GYPSSUM	W	WEST
H.B.	HOSE BIBB	w/	WITH
HC	HANDICAP	WC	WATER CLOSET
H.M.	HOLLOW METAL	WD	WOOD
HORIZ	HORIZONTAL	W/O	WITHOUT
HGT	HEIGHT	WP	WATERPROOF
I.D.	INSIDE DIAMETER (DIM)		
IN	INCH, INCHES		
INSUL	INSULATION		
INT	INTERIOR		

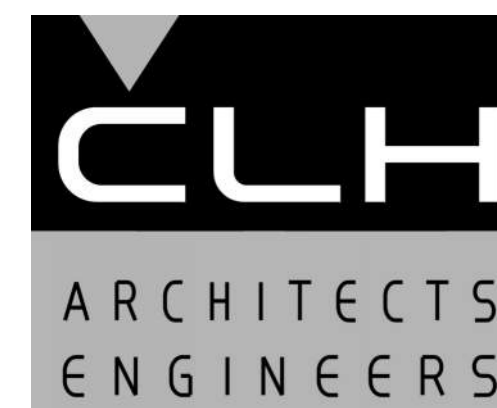

Case, Lowe & Hart, Inc. • 2484 Washington Blvd.  
Suite 510 • Ogden, Utah • 84401  
801.399.5821 • www.clhae.com

CONSULTANTS

STAMP

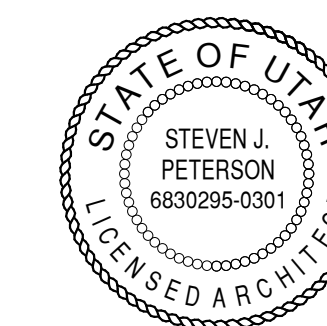

New Canopy

3801 Washington Blvd.  
South Ogden, Utah

MARK	DATE	DESCRIPTION

ISSUE DATE: 10/24/2019  
PROJECT NO: 19060  
CAD DWG FILE:  
DRAWN BY: KDL  
CHK'D BY: SIP

REVIEW SET

24 OCT 2019

SHEET TITLE

ARCHITECTURAL  
NOTES

SHEET NO:

A001

IF SHEET IS LESS THAN 22"x 34"  
IT IS A REDUCED PRINT.  
REDUCE SCALE ACCORDINGLY



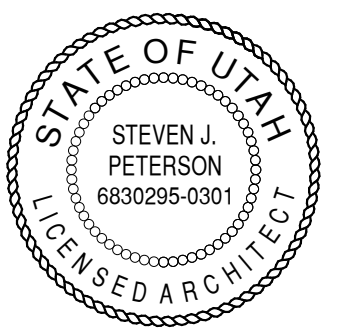

3801 Washington Blvd.  
South Ogden, Utah

MARK	DATE	DESCRIPTION

ISSUE DATE:	10/24/2019
PROJECT NO:	19060
CAD DWG FILE:	
DRAWN BY:	KDL
CHK'D BY:	SIP

REVIEW SET  
24 OCT 2019

SHEET TITLE

FLOOR PLAN

SHEET NO:

A101

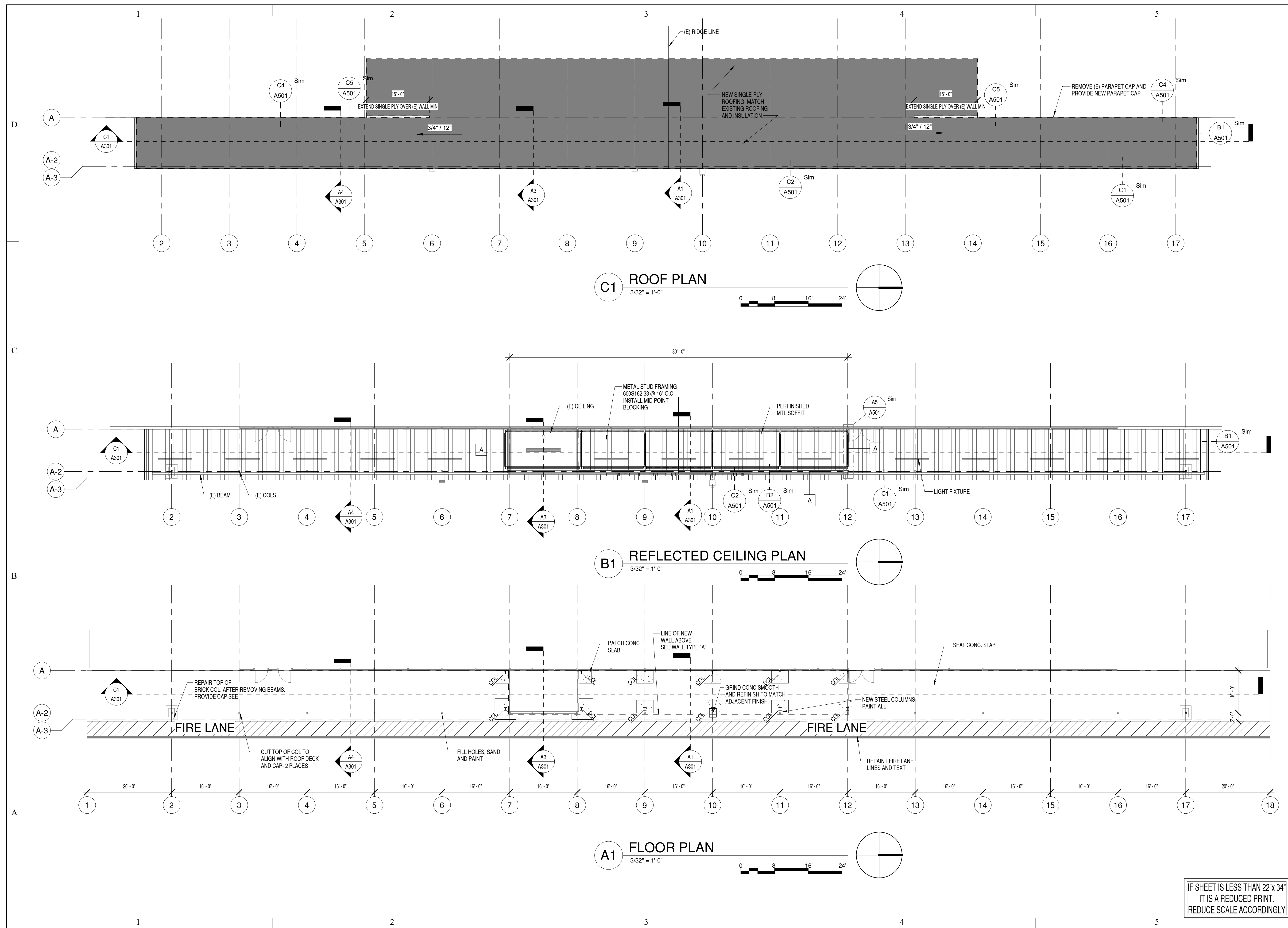

IF SHEET IS LESS THAN 22"x 34"  
IT IS A REDUCED PRINT.  
REDUCE SCALE ACCORDINGLY





3801 Washington Blvd.  
South Ogden, Utah

MARK	DATE	DESCRIPTION

ISSUE DATE:	10/24/2019
PROJECT NO:	19060
CAD DWG FILE:	
DRAWN BY:	KDL
CHK'D BY:	SIP

REVIEW SET  
24 OCT 2019

SHEET TITLE

EXTERIOR  
ELEVATIONS

SHEET NO:

A201

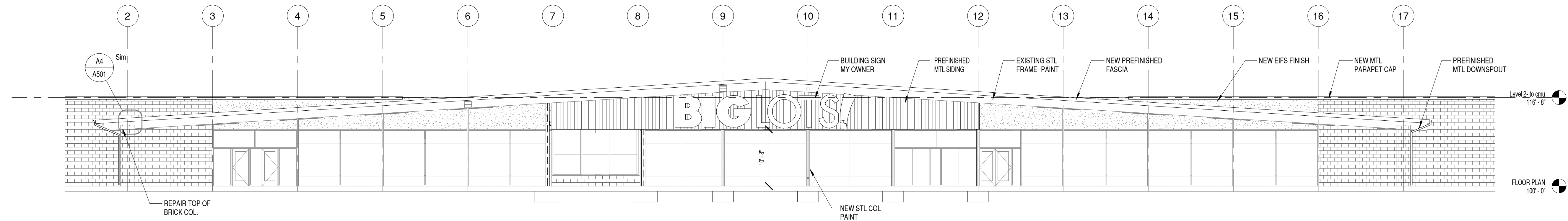

**B1 EAST EXTERIOR ELEVATION**  
3/32" = 1'-0"  
0 8' 16' 24'

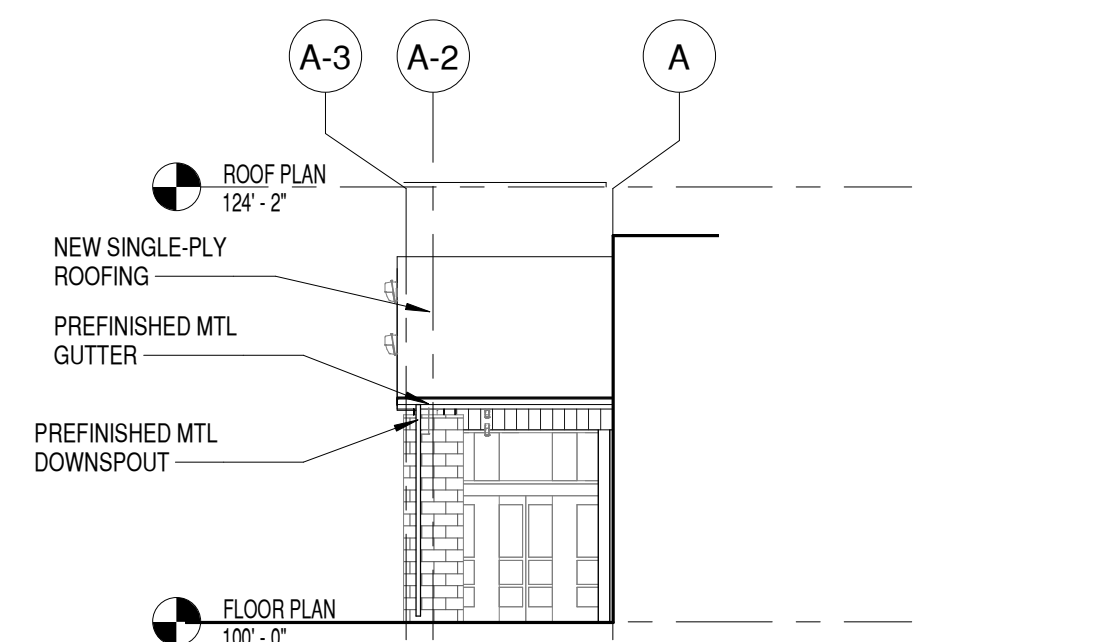

**B2 SOUTH EXTERIOR ELEVATION**  
3/32" = 1'-0"  
0 8' 16' 24'

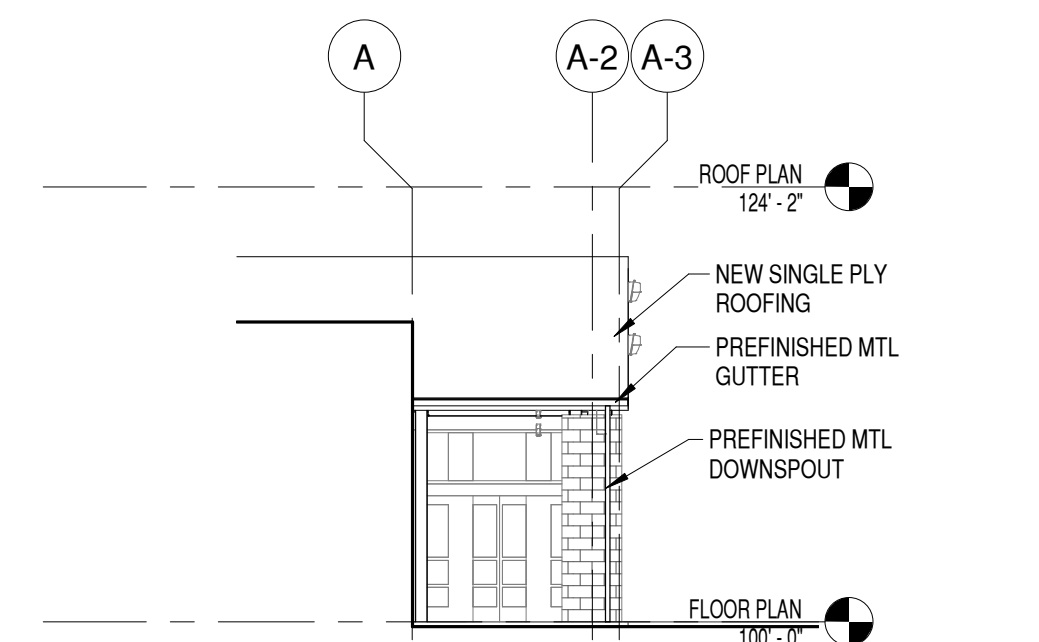

**B3 NORTH EXTERIOR ELEVATION**  
3/32" = 1'-0"  
0 8' 16' 24'

EXTERIOR COLOR SCHEDULE		
ITEM	MATERIAL	COLOR
PREFINISHED METAL SIDING:	"MBCI" PBC PANEL, SIGNATURE 200 26 GAUGE	COAL BLACK
PREFINISHED MTL SOFFIT	METAL- TBD	TBD
EIFS		TBD
STEEL FLASHINGS	PREFINISHED MTL	TBD
STEEL COLUMNS	STEEL	TBD

IF SHEET IS LESS THAN 22"x 34"  
IT IS A REDUCED PRINT.  
REDUCE SCALE ACCORDINGLY





3801 Washington Blvd.  
South Ogden, Utah

MARK	DATE	DESCRIPTION

ISSUE DATE:	10/24/2019
PROJECT NO:	19060
CAD DWG FILE:	
DRAWN BY:	KDL
CHK'D BY:	SIP

REVIEW SET  
24 OCT 2019

SHEET TITLE

SECTIONS

SHEET NO:

A301

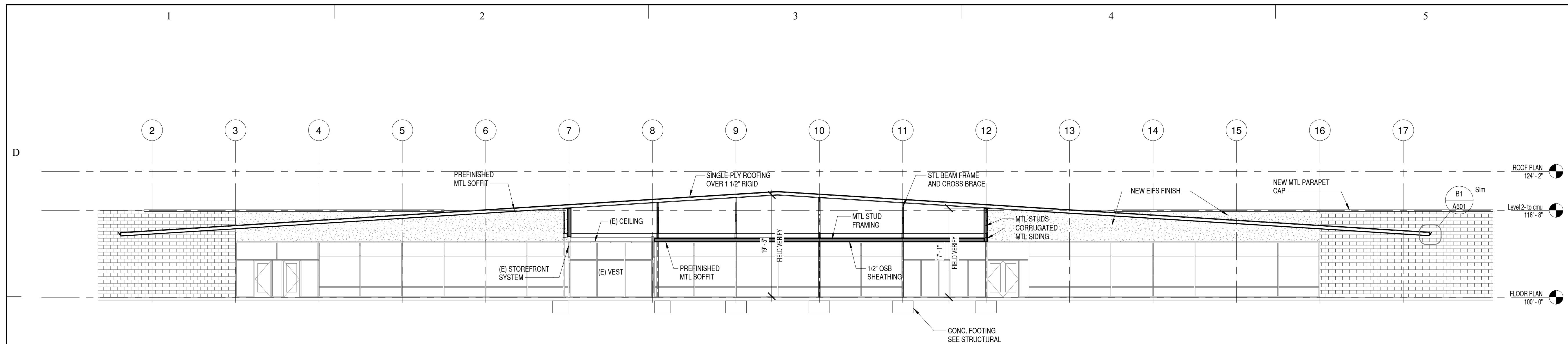

**C1 BUILDING SECTION**

3/32" = 1'-0"

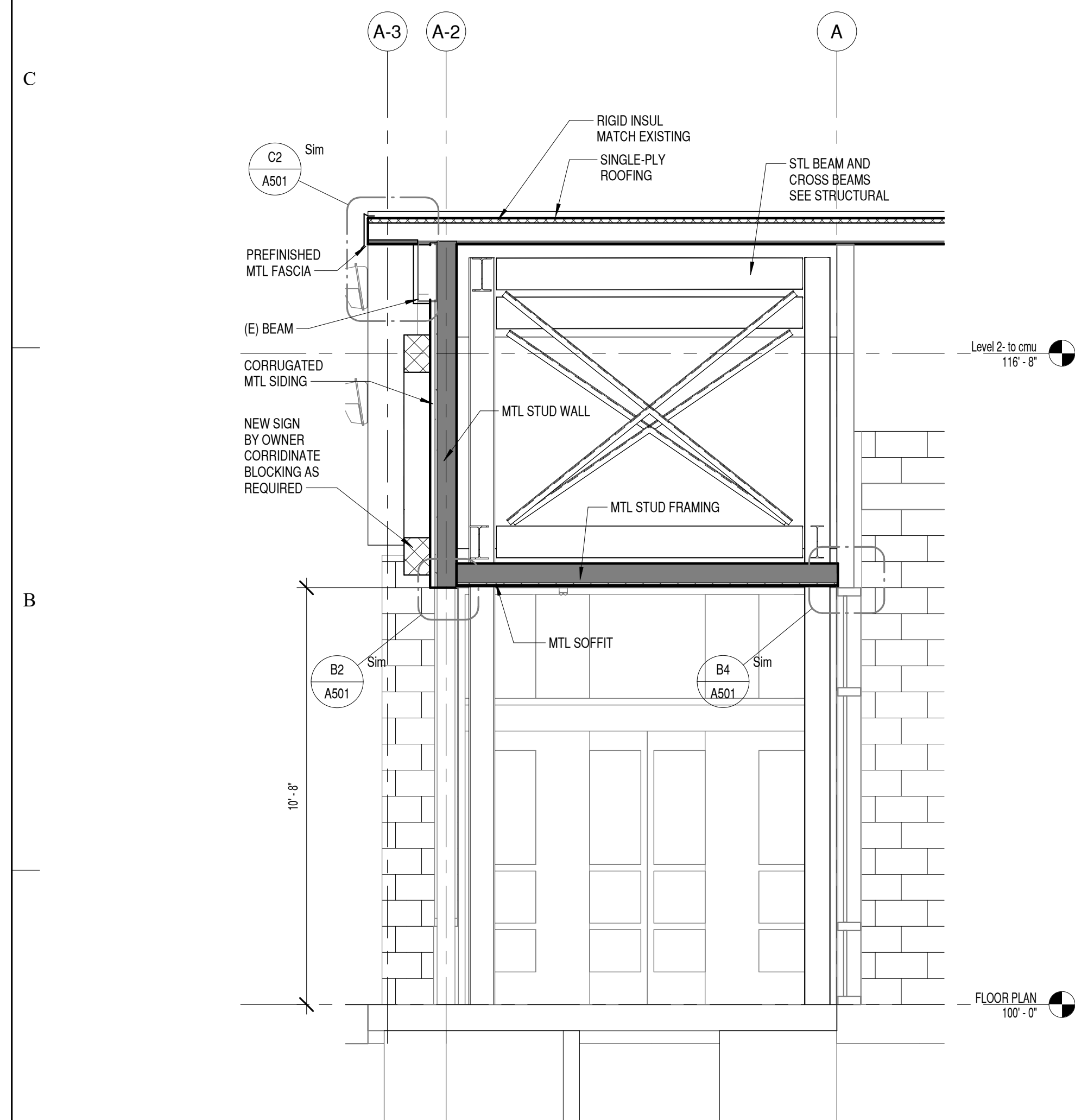
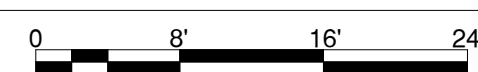

**A1 WALL SECTION**

3/8" = 1'-0"

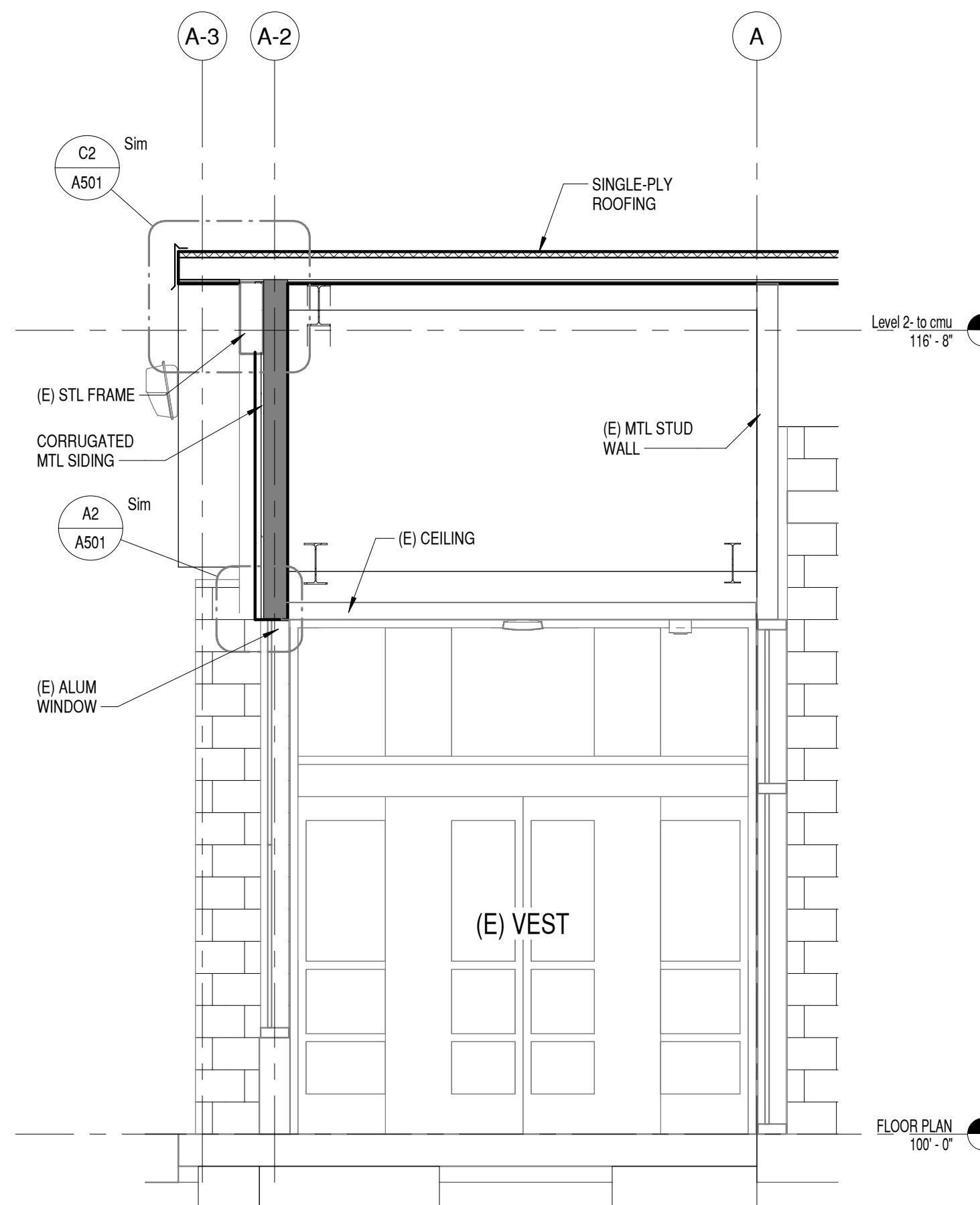
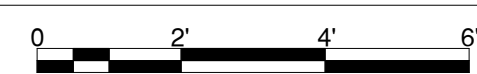

**A3 WALL SECTION**

3/8" = 1'-0"

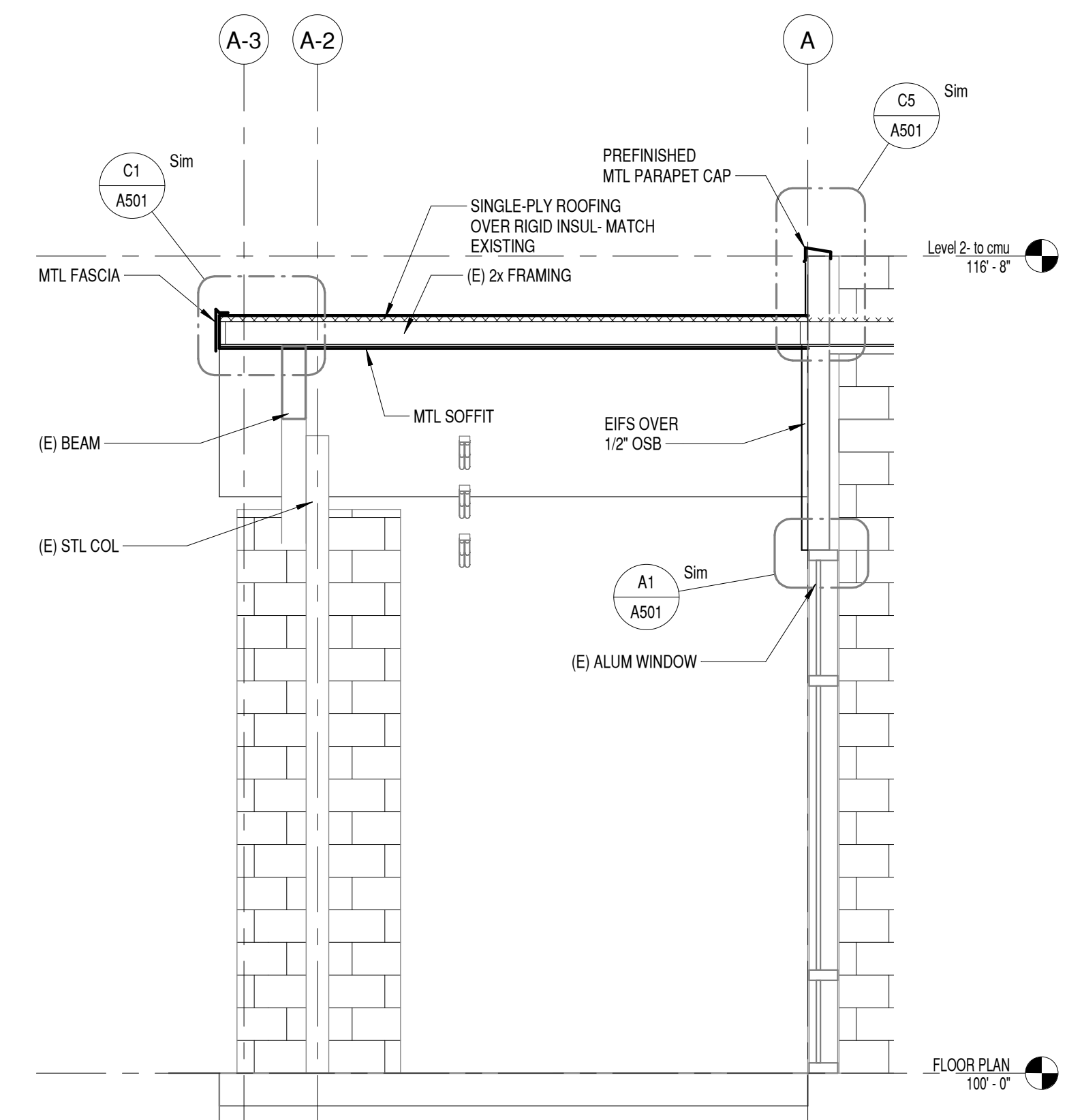
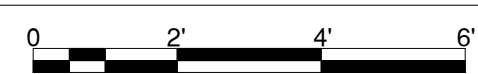

**A4 WALL SECTION**

3/8" = 1'-0"

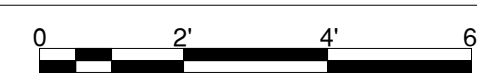

IF SHEET IS LESS THAN 22"x 34"  
IT IS A REDUCED PRINT.  
REDUCE SCALE ACCORDINGLY



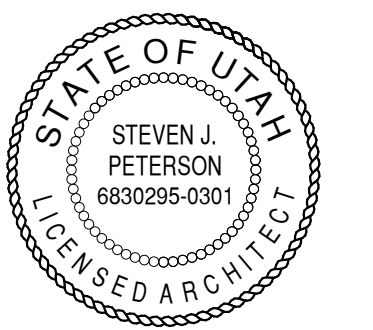

New Canopy

3801 Washington Blvd.  
South Ogden, Utah

MARK	DATE	DESCRIPTION

ISSUE DATE:	10/24/2019
PROJECT NO:	19060
CAD DWG FILE:	
DRAWN BY:	KDL
CHK'D BY:	SJP

REVIEW SET

24 OCT 2019

SHEET TITLE

DETAILS

SHEET NO:

A501

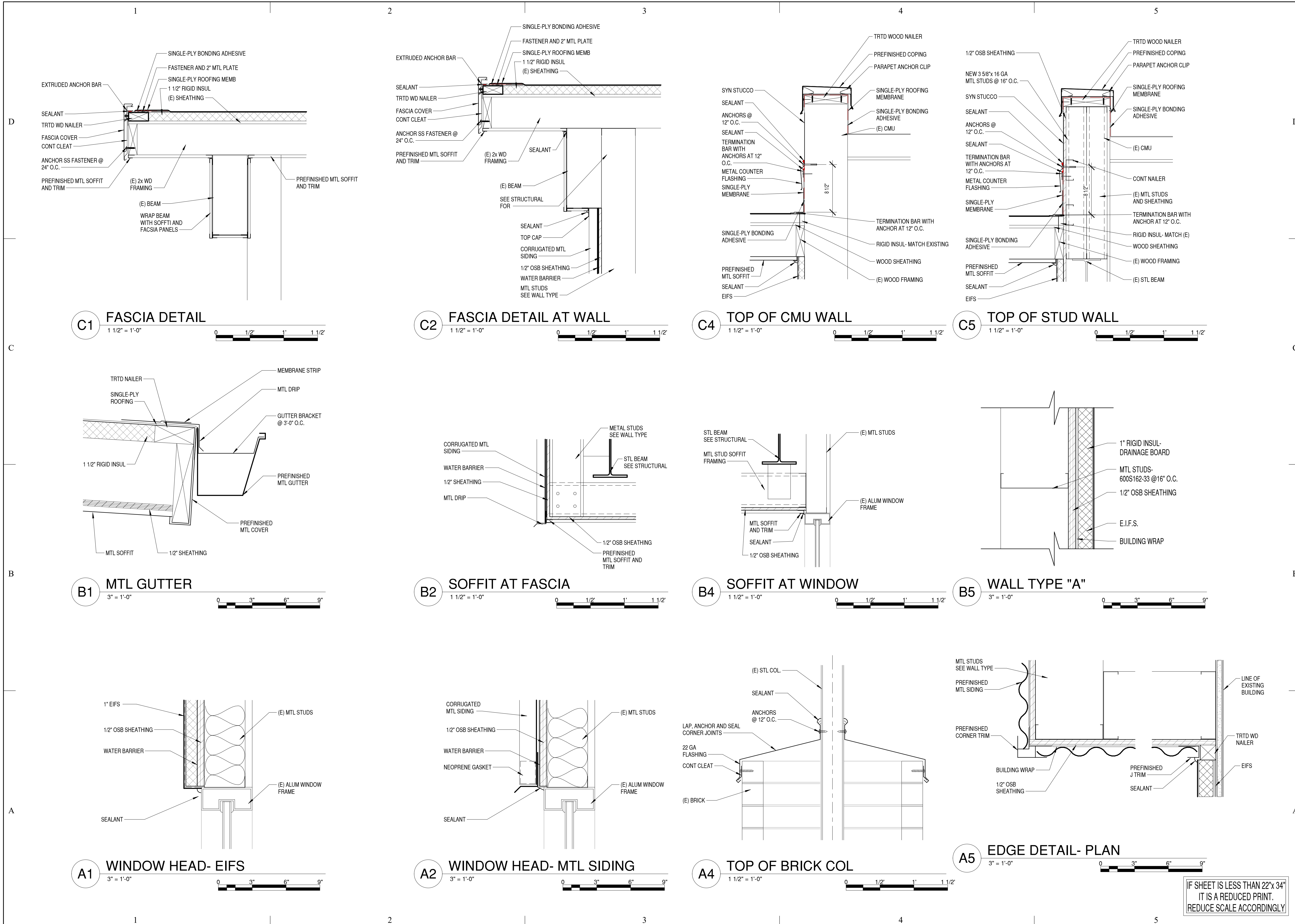

IF SHEET IS LESS THAN 22"x 34"  
IT IS A REDUCED PRINT.  
REDUCE SCALE ACCORDINGLY



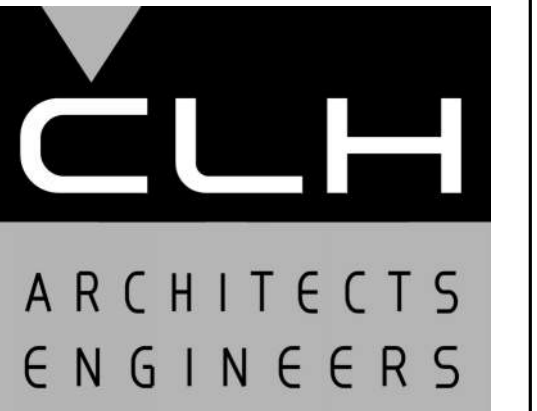
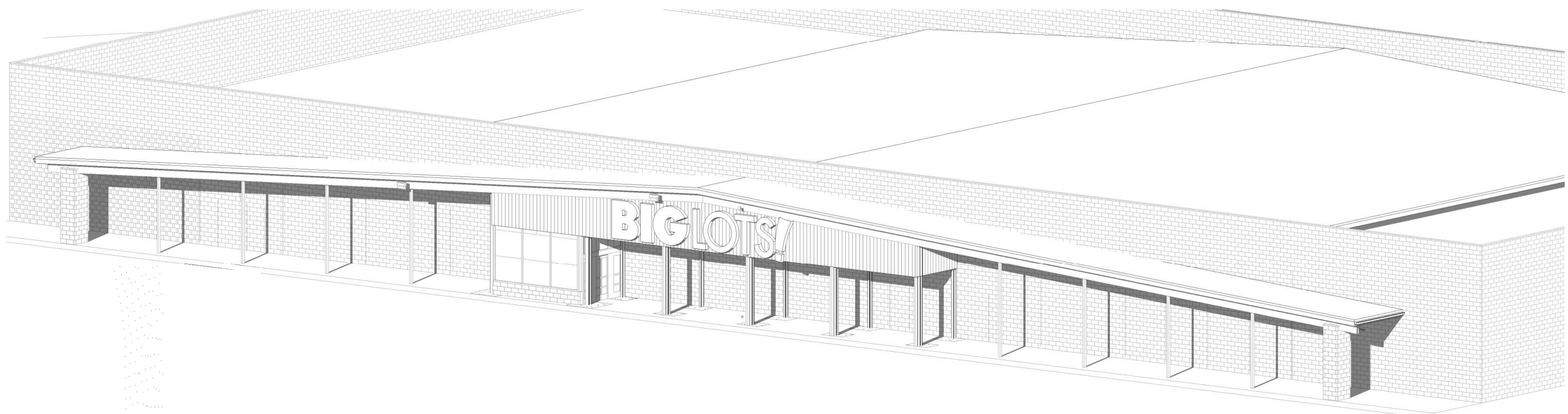
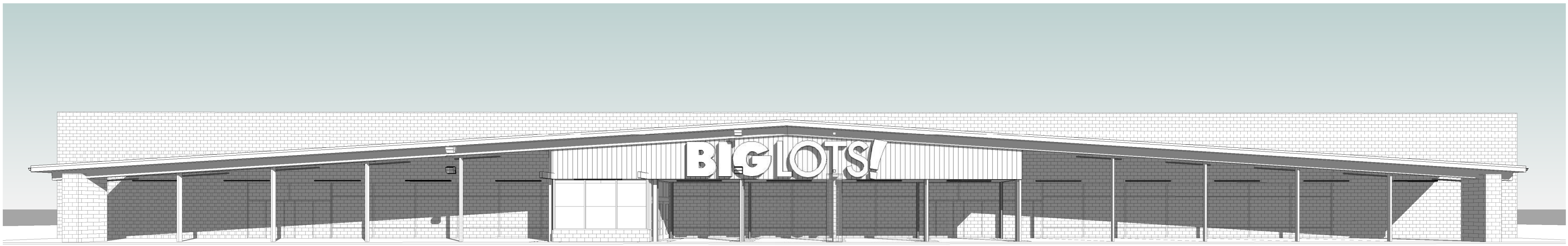

Case, Lowe & Hart, Inc. • 2484 Washington Blvd.  
Suite 510 • Ogden, Utah • 84401  
801.399.5821 • www.clhae.com

CONSULTANTS

STAMP

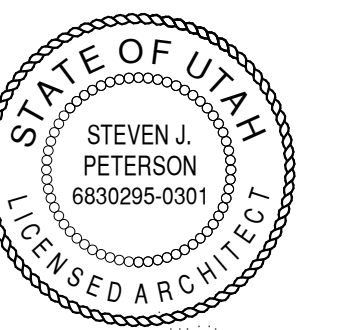

New Canopy

3801 Washington Blvd.  
South Ogden, Utah

MARK	DATE	DESCRIPTION

ISSUE DATE:	10/24/2019
PROJECT NO:	19060
CAD DWG FILE:	
DRAWN BY:	KDL
CHK'D BY:	SIP

REVIEW SET  
24 OCT 2019

SHEET TITLE

3D VIEW



SHEET NO:

A801



IF SHEET IS LESS THAN 22"x 34"  
IT IS A REDUCED PRINT.  
REDUCE SCALE ACCORDINGLY



**LIGHTING**

-  EXISTING FIXTURE TO BE REMOVED AND RE-INSTALLED
-  RELOCATED EXISTING FIXTURE
-  JUNCTION BOX

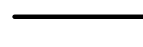
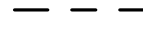
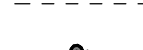
**CIRCUITING**

- D**  WIRING CONCEALED IN CEILING OR WALL
-  WIRING CONCEALED IN FLOOR
-  WIRING EXISTING
-  CROSSLINES INDICATE NUMBER OF #12 THHN/THWN CONDUCTORS. GROUND IS REPRESENTED BY CROSSLINE WITH DOT ON TOP. OTHER CONDUCTORS AND CONDUIT AS INDICATED.
-  BRANCH CIRCUIT HOMERUN TO PANELBOARD; NUMBER OF ARROWS INDICATE NUMBER OF CIRCUITS. LETTER AND NUMBER NOTATION IDENTIFIES PANEL AND CIRCUIT NUMBER(S).

**PANELBOARDS AND POWER EQUIPMENT**

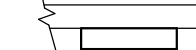
-  (E) FLUSH MOUNTED PANELBOARD AND CABINET
-  (E) SURFACE MOUNTED PANELBOARD AND CABINET

**SECURITY SYSTEMS**

-  (E) GLASS BREAK SENSOR

**ABBREVIATIONS**

-  KEYED NOTE CALLOUT - NUMBER AS INDICATED
- 3R NEMA 3R ENCLOSURE
- 12 NEMA 12 ENCLOSURE
- 4 NEMA 4 ENCLOSURE
- 4X NEMA 4X ENCLOSURE
- A AMPERE
- AFF ABOVE FINISHED FLOOR
- AIC AMPERES INTERRUPTING CAPACITY
- APPROX APPROXIMATELY
- BC BARE COPPER
- C CONDUIT
- CB CIRCUIT BREAKER
- CKT CIRCUIT
- CO CONDUIT ONLY
- CONC CONCRETE
- CU COPPER
- (E) EXISTING
- EMT ELECTRICAL METALLIC TUBING
- FA FIRE ALARM
- FLR FLOOR
- FT FEET
- GFI GROUND FAULT CIRCUIT-INTERRUPTER
- GND or GRD GROUND
- HID HIGH INTENSITY DISCHARGE
- IMC INTERMEDIATE METAL CONDUIT
- IN INCHES
- IP INPUT
- KVA KILOVOLT AMPERE
- KVAR KILOVOLT CAPACITANCE
- KWH KILOWATT HOUR
- LAN LOCAL AREA NETWORK
- MAX MAXIMUM
- MH METAL HALIDE
- MIN MINIMUM
- (N) NEW
- NEC NATIONAL ELECTRICAL CODE
- NEMA NATIONAL ELECTRICAL MANUFACTURING ASSOCIATION
- NIC NOT IN CONTRACT
- NL NIGHT LIGHT ON UNSWITCHED CIRCUIT
- OFOI OWNER FURNISHED OWNER INSTALLED
- OFCI OWNER FURNISHED CONTRACTOR INSTALLED
- O.C. ON CENTER
- O.H. OVERHEAD
- RM ROOM
- RGC RIGID GALVANIZED CONDUIT
- TTB TELEPHONE TERMINAL BOARD
- TYP TYPICAL
- UON UNLESS OTHERWISE NOTED
- V VOLT
- W WATT
- w/ WITH
- WP WEATHERPROOF
- +12' MOUNTING HEIGHT ABOVE FINISHED FLOOR OR GRADE

**GENERAL NOTES:**

1. ALL CONDUCTORS TO BE THHN/THWN COPPER.
2. NOT ALL SYMBOLS APPEAR ON THESE PLANS.

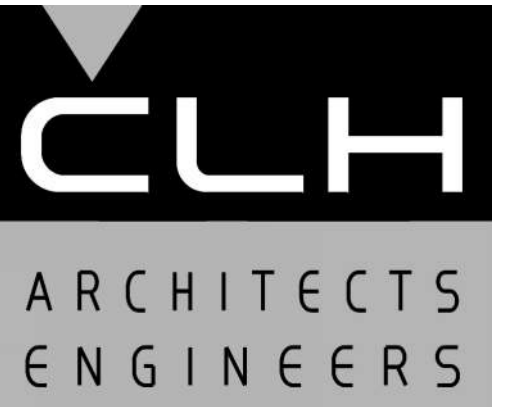

Case, Lowe & Hart, Inc. • 2484 Washington Blvd.  
Suite 510 • Ogden, Utah • 84401  
801.399.5821 • www.clhac.com

**CONSULTANTS**

**STAMP**

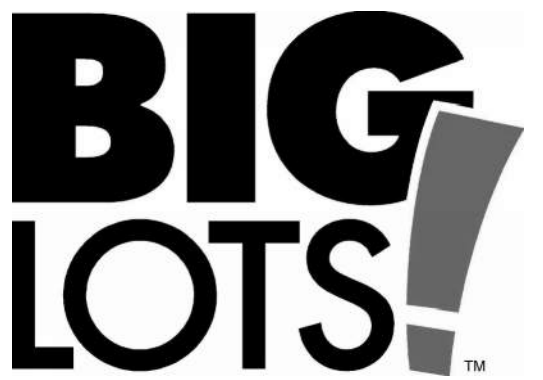
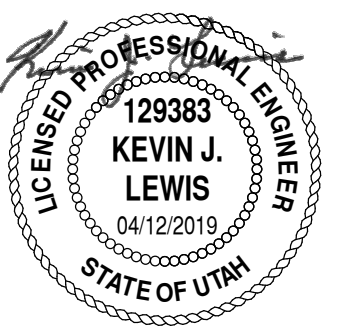

**New Canopy**

3801 Washington Blvd.  
South Ogden, Utah

MARK	DATE	DESCRIPTION

ISSUE DATE:	10/24/2019
PROJECT NO:	19060
CAD DWG FILE:	
DRAWN BY:	J.M.S.
CHK'D BY:	K.J.L.

**REVIEW SET**  
24 OCT 2019

**SHEET TITLE**

**ELECTRICAL LEGEND**

**SHEET NO:**

**E001**

IF SHEET IS LESS THAN 22"x 34"  
IT IS A REDUCED PRINT.  
REDUCE SCALE ACCORDINGLY



ELECTRICAL LIGHTING KEYED NOTES	
MARK	NOTE
EL1	RE-CONNECT TO EXISTING CIRCUIT.
EL2	RE-CONNECT PARKING LIGHTING.
EL3	RE-INSTALL ALARM / HORN.
EL4	RE-CONNECT POWER TO SIGN.

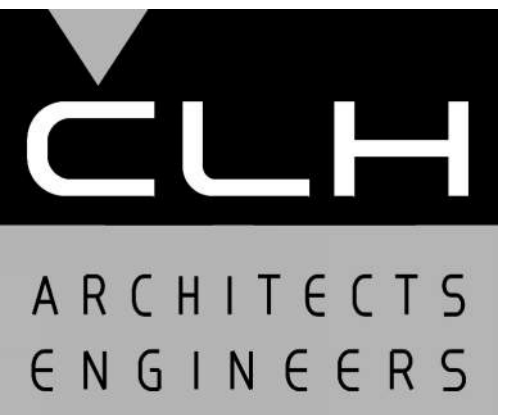

Case, Lowe & Hart, Inc. • 2484 Washington Blvd.  
Suite 510 • Ogden, Utah • 84401  
801.399.5821 • www.clhac.com

CONSULTANTS

STAMP

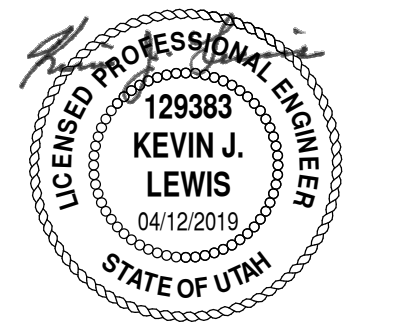

New Canopy

3801 Washington Blvd.  
South Ogden, Utah

MARK	DATE	DESCRIPTION

ISSUE DATE:	10/24/2019
PROJECT NO:	19060
CAD DWG FILE:	
DRAWN BY:	J.M.S.
CHK'D BY:	K.J.L.

REVIEW SET  
24 OCT 2019

SHEET TITLE

ELECTRICAL LIGHTING PLAN

SHEET NO:

EL 101

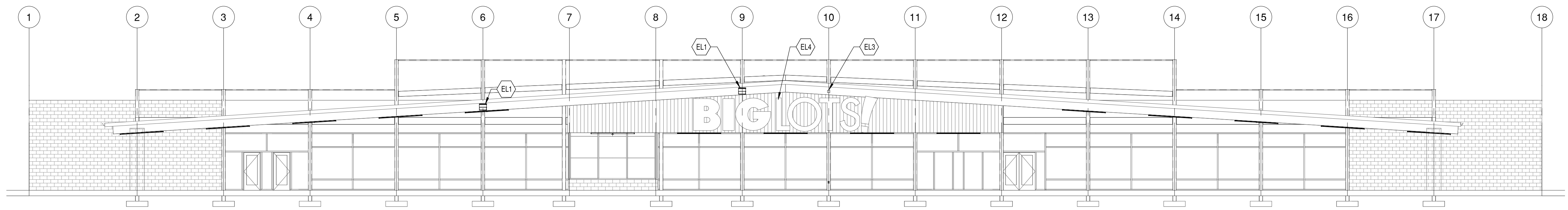

**C1 FRONT ELEVATION LIGHTING**  
3/32" = 1'-0"

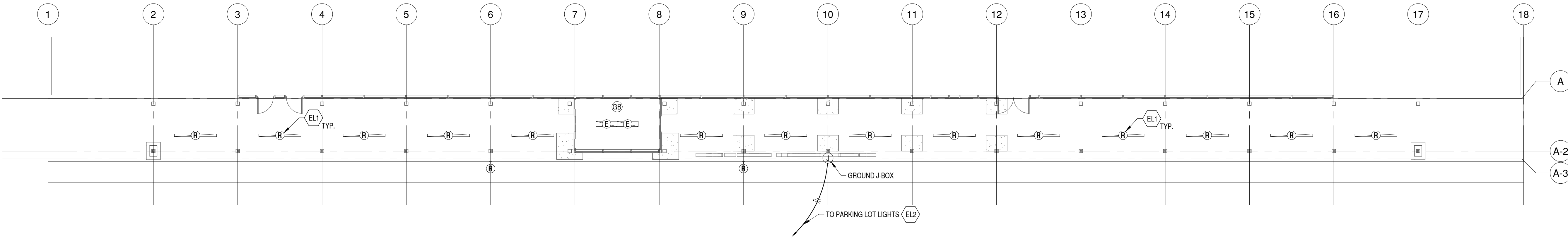

**A1 ELECTRICAL LIGHTING PLAN**  
3/32" = 1'-0"

IF SHEET IS LESS THAN 22"x 34"  
IT IS A REDUCED PRINT.  
REDUCE SCALE ACCORDINGLY

10/24/2019 9:59:10 AM