

CAMP HULL VALLEY IMPROVEMENTS PRESTON, IDAHO



PROJECT TEAM:

OWNER:

THE CHURCH OF JESUS CHRIST OF LATTER-DAY SAINTS
A UTAH CORPORATION SOLE
50 EAST NORTH TEMPLE STREET
SALT LAKE CITY, UTAH 84150

ARCHITECT:

STUDIO 333 ARCHITECTS
333 24TH STREET
OGDEN, UTAH 84401
801.394.3033

CIVIL:

HCF
8160 S. HIGHLAND DR. STE. 106
SANDY, UTAH 84093
385.707.3140

ELECTRICAL:

BEAZER ENGINEERING INC.
P.O. BOX 652
MILLVILLE, UTAH 84326-0652
435.770.8999

SHEET INDEX:

G1.1 COVER SHEET/GENERAL INFORMATION

SITE CIVIL

CG0.1	CIVIL COVER SHEET
CG0.2	NOTES
CG0.3	OVERALL SITE PLAN
CT.1	SITE PLAN AREA 1
C2.1	SITE PLAN AREA 2
C3.1	SITE PLAN AREA 3
C4.1	SITE PLAN AREA 4
C5.1	SITE PLAN AREA 5
C6.1	SITE PLAN AREA 6
SP7.1	WEST RESTROOM SEPTIC PLAN
SP8.1	EAST RESTROOM SEPTIC PLAN
SP9.1	TRAILER SEPTIC PLAN
CD1.1	DETAILS
CD2.1	DETAILS
CD3.1	DETAILS
CD4.1	DETAILS
CD5.1	DETAILS
CD6.1	DETAILS

ELECTRICAL DRAWINGS

ES.1	ELECTRICAL SITE PLAN
E1.1	PAVILION AND RESTROOM ELECTRICAL PLANS
E1.2	DIAGRAMS AND SCHEDULES

PAVILION DRAWINGS

PAVILION A1.1	FOOTING, FOUNDATION, SLAB & FLOOR PLANS
PAVILION A1.2	WALL SECTIONS & DETAILS
PAVILION A1.3	ROOM FINISH, DOOR & WINDOW SCHEDULES & DETAILS
PAVILION A2.1	BUILDING ELEVATIONS
PAVILION P1.1	PLUMBING PLAN, SECTION & FIXTURE SCHEDULE
PAVILION P2.1	PLUMBING DETAILS

DINING SHELTER DRAWINGS

DINING SHELTER A1.1	PLANS, NOTES AND DETAILS
---------------------	--------------------------

RESTROOM/SHOWER DRAWINGS (2 Restroom/Shower Building required)

RR/SHOWER A1.1	FLOOR PLAN, ELEVATIONS & BUILDING SECTION
RR/SHOWER A2.1	SECTION AND DETAILS
RR/SHOWER A3.1	ROOM FINISH & DOOR SCHEDULES & DETAILS
RR/SHOWER S1.1	FOOTING/FOUNDATION PLAN AND ROOF FRAMING PLAN
RR/SHOWER P1.1	PLUMBING FLOOR PLANS AND ISOMETRICS
RR/SHOWER P2.1	PLUMBING DETAILS
RR/SHOWER M1.1	MECHANICAL PLAN, SCHEDULES AND DETAILS

DEFERRED SUBMITTALS:

Contractor is responsible to submit deferred submittals in accordance with IBC 107.3.4.1 as part of the submittal process. The Contractor shall submit all ICC ERS reports for items noted:

06 1753 Shop fabricated wood trusses (for restroom/shower buildings)

Smith Steelworks engineered drawings and structural calculations for pre-engineered structures:

- Dining shelters
- Pavilion

VICINITY MAP:

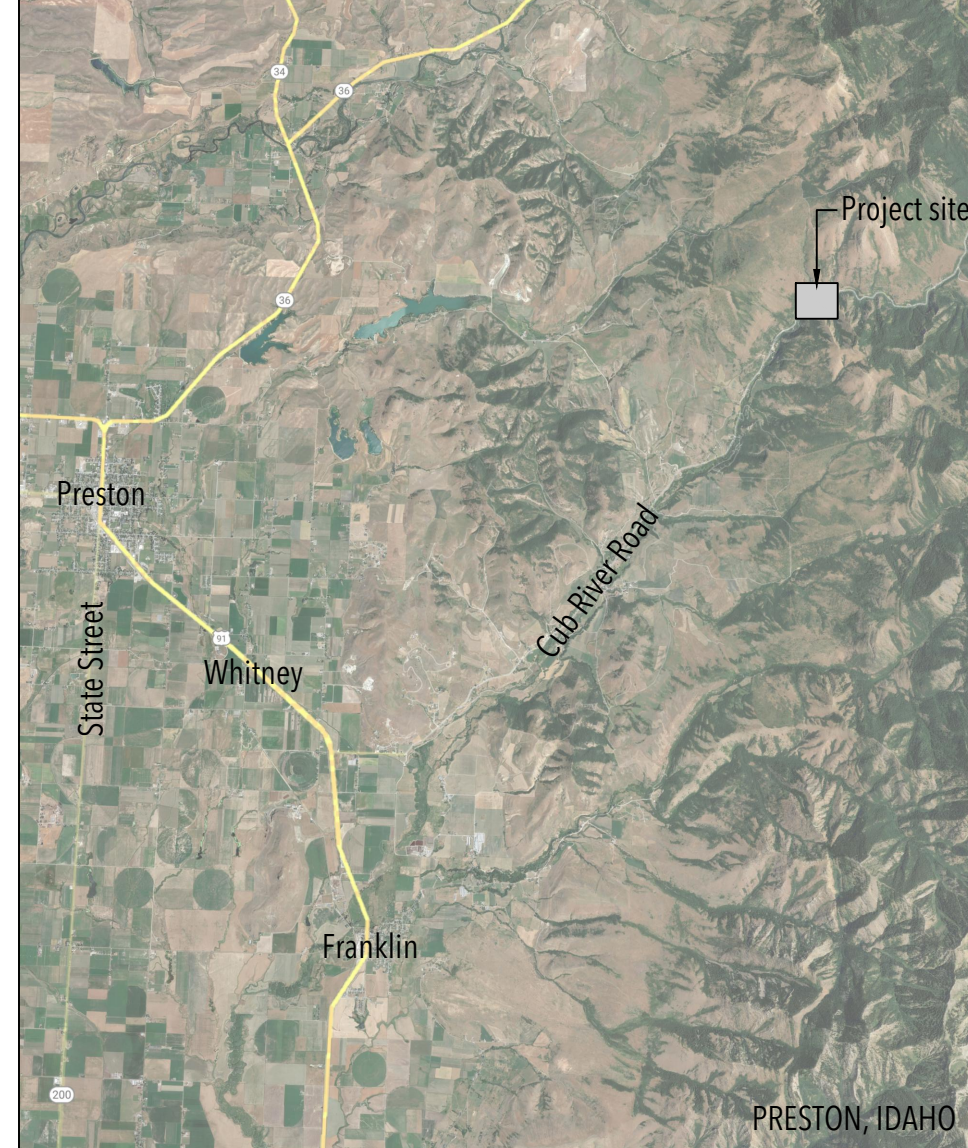

STANDARD SYMBOL LEGEND:

Building/Wall Section Reference Sheet Reference	
Detail Reference Sheet Reference	
Elevation Marker	
Elevation Reference Sheet Reference	
Room Number Door Designation	
Window Designation	
Reflected Ceiling Elevation	
Room Title Room Number	
Partition Type	
Keyed Note	

STANDARD SYMBOL LEGEND:

	Asphalt		Gravel / Rock Fill
	Batt Insulation		Gypsum Board
	Ceramic Tile (in elevation)		Particle Board
	Concrete		Sand, Plaster, Stucco & Sand Setting Beds
	Concrete & Plaster (in elevation)		Plywood
	Concrete Masonry Units		Rigid Insulation
	Brick		Steel
	Compacted Backfill		Wood Framing (cont. member)
	Earth		Wood Framing (interrupted member)
	Finish Lumber		Metal Studs
	Glass		

ABBREVIATIONS:

@	At	eb	Expansion Bolt	max	Maximum
Ø	Diameter	eifs	Exterior Insul Fin System	meh	Mechanical
#	Pound or Number	exp jt	Expansion Joint	mtl	Metal
ab	Anchor Bolt	elec	Electrical	mfr	Manufacturer
act	Acoustical Tile	elev	Elevation	min	Minimum
adj	Adjustable	eq	Equal	nic	Not In Contract
aff	Above Finish Floor	equip	Equipment	nts	Not To Scale
alum	Aluminum	ewc	Elec Water Cooler	o.c.	On Center
bd	Board	exist	Existing	pl	Plate
bdg	Building	ext	Exterior	pl	Property Line
bm	Beam	fd	Floor Drain	plm lam	Plastic Laminate
bot	Bottom	fdn	Foundation	plywd	Plywood
brg	Bearing	feb	Fire Extinguisher Cab	rb	Resilient Base
bur	Built Up Roofing	fin fl	Finish(ed) Floor	ref	Reference
cab	Cabinet	ft	Foot or Feet	reinf	Reinforce(d) (ing)
ct	Control Joint	ftg	Footing	rfg	Roofing
CL	Center Line	fur	Furring	rm	Room
clg	Ceiling	ga	Gauge	sc	Solid Core
cmu	Concrete Masonry Units	galv	Galvanized	sch	Schedule
col	Column	gc	General Contractor	sec	Section
conc	Concrete	gl	Glass	sim	Similar
const	Construction	gyp bd	Gypsum Board	spec	Specification
const jt	Construction Joint	hc	Hollow Case	sq	Square
cont	Continuous	hdwd	Hardwood	stl	Steel
contr	Contract(or)	hdwr	Hardware	temp gl	Tempered Glass
corr	Corridor	hdrl	Handrail	typ	Typical
ct	Ceramic Tile	hm	Hollow Metal	vct	Vinyl Composition Tile
det	Detail	id	Inside Diameter	w/	With
djm	Dimension	incl	Include(d) (ing)	wid	Width
dn	Down	insul	Insulation	wdw	Window
dr	Door	int	Interior	w/o	Without
ea	Each	jt	Joint	wsc	Wainscot

STUDIO 333 ARCHITECTS
333 24TH STREET
OGDEN, UT 84401
801.394.3033

LICENSED ARCHITECT
NO. AR 984269

Tony K. Pantone

TONY K. PANTONE
STATE OF IDAHO

CAMP HULL VALLEY IMPROVEMENTS
10100 EAST CUB RIVER RD.
PRESTON, IDAHO

NO.	DATE	DESCRIPTION

DATE: 03.15.23
PROJECT NUMBER: 2223
PROPERTY NUMBER: 501-737121050101

COVER SHEET/GENERAL
INFORMATION

G1.1

THE CHURCH OF JESUS CHRIST OF LATTER-DAY SAINTS CAMP HULL VALLEY

HOMESTEAD ENTRY SURVEY NO. 87 (156.92 ACRES)
AND TRACT 37 (199.78 ACRES)
WITHIN
UNSURVEYED SECTION 34 T14S R41E
UNSURVEYED SECTION 3 T15S R41E
FRANKLIN COUNTY, IDAHO

SHEET INDEX		
NUMBER	TITLE	SHEET NUMBER
1	CIVIL COVER SHEET	CG0.1
2	NOTES SHEET	CG0.2
3	OVERALL SITE PLAN	CG0.3
4	SITE PLAN AREA 1	C1.1
5	SITE PLAN AREA 2	C2.1
6	SITE PLAN AREA 3	C3.1
7	SITE PLAN AREA 4	C4.1
8	SITE PLAN AREA 5	C5.1
9	SITE PLAN AREA 6	C6.1
10	WEST RESTROOM SEPTIC PLAN	SP7.1
11	EAST RESTROOM SEPTIC PLAN	SP8.1
12	TRAILER SEPTIC PLAN	SP9.1
13	DETAILS	CD1.1
14	DETAILS	CD2.1
15	DETAILS	CD3.1
16	DETAILS	CD4.1
17	DETAILS	CD5.1
18	SEPTIC DETAILS	CD6.1

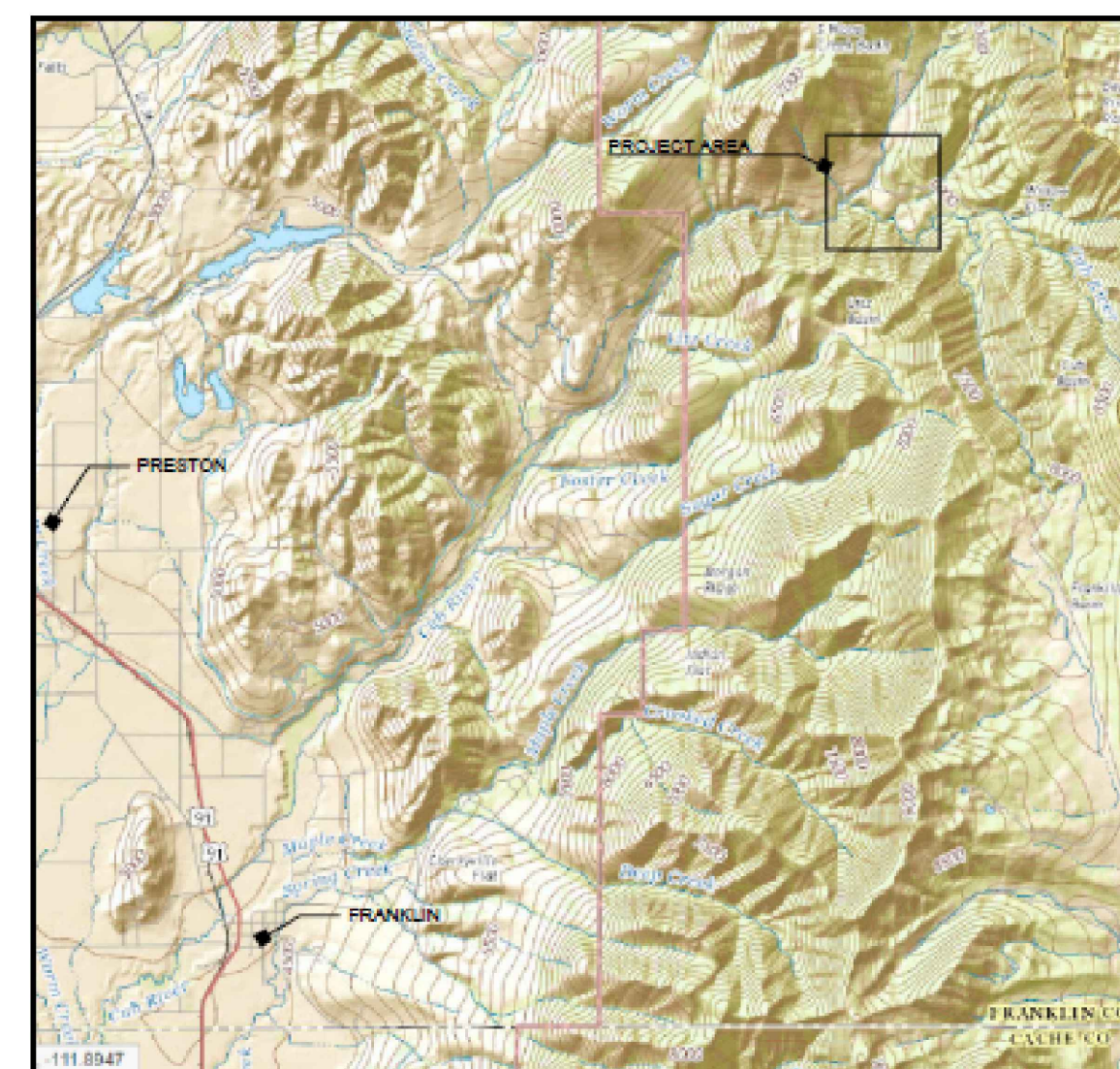
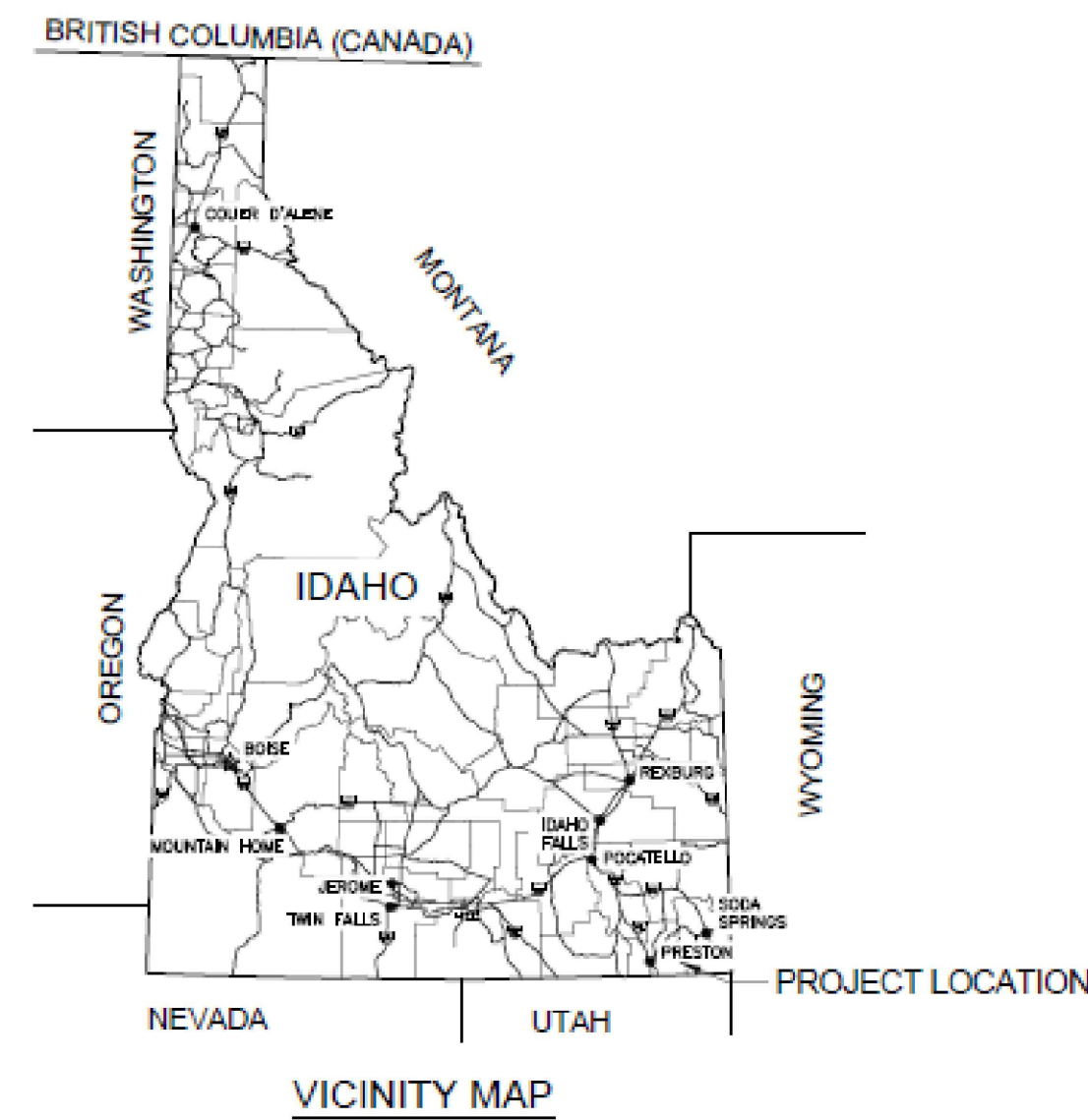

ARCHITECT (STUDIO 333 ARCHITECTS)
BRIAN BOTT, AIA
801-384-3033
brian@studio333architects.com

CIVIL ENGINEER (HCF)
JOSEPH DANIEL HALES P.E.
385-557-1500
dhales@hcfcorp.com

NO.	DATE	DESCRIPTION

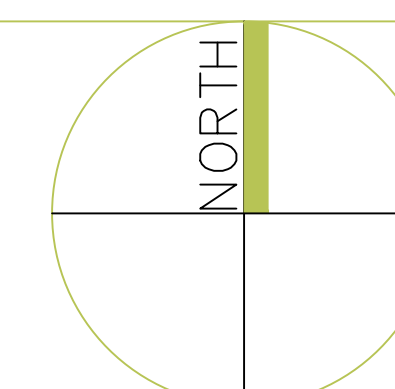

1. GENERAL NOTES

- IT SHALL BE THE CONTRACTOR'S RESPONSIBILITY TO PERFORM CONSTRUCTION ACTIVITIES PER THE CONTRACT DOCUMENTS. ANY ADDITIONS, DELETIONS, OR MODIFICATIONS SHALL FIRST MEET WITH THE WRITTEN APPROVAL OF THE ENGINEER AND THE OWNER. THE CONTRACTOR SHALL HAVE EXPERIENCE IN THE WORK PERFORMED AND KNOWLEDGE OF HOW TO CONSTRUCT SIMILAR FACILITIES AND ITEMS IN THE PLANS. ALL SEPTIC FACILITIES MUST BE INSTALLED BY A QUALIFIED CONTRACTOR PER IDAHO DEQ AND SEIPH.
- IT IS INTENDED THAT THESE PLANS AND SPECIFICATIONS REQUIRE ALL LABOR AND MATERIALS NECESSARY AND PROPER FOR THE WORK CONTEMPLATED AND THAT THE WORK BE COMPLETED IN ACCORDANCE WITH THEIR TRUE INTENT AND PURPOSE. THE CONTRACTOR SHALL NOTIFY THE ENGINEER IMMEDIATELY REGARDING ANY DISCREPANCIES OR AMBIGUITIES WHICH MAY EXIST IN THE PLANS OR SPECIFICATIONS. THE ENGINEER'S INTERPRETATION THEREOF SHALL BE CONCLUSIVE. IN ALL CASES, THE CONTRACTOR SHALL FOLLOW THE OWNER'S STANDARDS AND SPECIFICATIONS. THE SPECIFICATIONS SHALL GOVERN.
- PRIOR TO ANY WORK BEING PERFORMED, THE CONTRACTOR SHALL CONTACT THE OWNER FOR A PRE-CONSTRUCTION MEETING.
- CONTRACTOR SHALL OBTAIN ALL NECESSARY PERMIT(S) AND COMPLY WITH ALL REQUIREMENTS OF GOVERNING AGENCIES.
- CONTRACTOR IS SOLELY RESPONSIBLE FOR CONFORMANCE WITH LOCAL, STATE AND FEDERAL CODES GOVERNING SHORING AND BRACING OF EXCAVATIONS AND TRENCHES. CONTRACTOR IS RESPONSIBLE FOR THE SAFETY OF THE PUBLIC AND PROTECTION OF PERSONNEL AND WORKERS. TRENCH SUPPORTS AND DEWATERING SHALL BE THE RESPONSIBILITY OF THE CONTRACTOR.
- CONTRACTOR TO FILE NOTICE OF INTENT (NOI) AND NOTICE OF TERMINATION (NOT) WITH THE STATE OF IDAHO.
- CONTRACTOR SHALL BE SOLELY RESPONSIBLE TO PROVIDE ALL TEMPORARY EROSION CONTROL AND MAINTENANCE.
- DUST CONTROL SHALL BE PROVIDED AT ALL TIMES, AT THE CONTRACTOR'S EXPENSE, TO MINIMIZE ANY DUST NUISANCE.
- THE CONTRACTOR SHALL BE RESPONSIBLE FOR ADEQUATELY SCHEDULING INSPECTION AND TESTING OF ALL FACILITIES CONSTRUCTED UNDER THIS CONTRACT. ALL TESTING SHALL CONFORM TO THE SPECIFICATIONS ON THESE PLANS OR GOVERNING AGENCIES, WHICHEVER IS STRICTER.
- CONSTRUCTION STAKING SHALL BE THE RESPONSIBILITY OF THE CONTRACTOR.
- ALL WORK MUST BE DONE ACCORDING TO THE OWNER, COUNTY, STATE OF IDAHO, AND ANY FEDERAL STANDARDS INCLUDING THE MANUAL OF STANDARD PLANS LATEST EDITION PUBLISHED BY THE IDAHO CHAPTER OF THE AMERICAN PUBLIC WORKS ASSOCIATION (APWA) AND THE IDAHO CHAPTER OF THE ASSOCIATED GENERAL CONTRACTORS OF AMERICA (AGC) LATEST EDITION. THE SPECIFICATIONS AND THE STANDARD PLANS LATEST VERSION.
- CONTRACTOR MUST WARRANT ALL ITEMS PER THE OWNER'S WARRANTY TERMS.
- ALL WORK MUST BE PERFORMED WITHIN THE PROPERTY BOUNDARY.
- THE CONTRACTOR HAS THE ULTIMATE RESPONSIBILITY OF LOCATING ALL UNDERGROUND UTILITIES AND PROTECTING THEM FROM DAMAGE. DAMAGED UTILITIES SHALL BE REPAIRED AT THE CONTRACTOR'S EXPENSE.
- NO GEOTECHNICAL INVESTIGATION WAS COMPLETED AS A PART OF THIS PROJECT.
- IT IS THE RESPONSIBILITY OF THE CONTRACTOR TO MINIMIZE TREE CUTTING AND GRADING CHALLENGES THROUGHOUT THE PROJECT. ALL NEW FACILITIES ARE SHOWN AT APPROXIMATE LOCATIONS. CONTRACTOR TO RECEIVE FINAL LOCATION PER OWNERS REQUEST.
- CONTRACTOR TO REMOVE ALL ORGANIC, DELETERIOUS, AND FOREIGN OBJECTS UNDER BUILDINGS AND OTHER NEW FACILITIES.
- ALL SURFACE DISRUPTIONS, EXISTING LANDSCAPING, IRRIGATION SYSTEMS, OR OTHER SITE FEATURES DISTURBED BY CONSTRUCTION ACTIVITIES SHALL BE RESTORED TO EXISTING OR BETTER CONDITION.
- THE CONTRACTOR IS RESPONSIBLE TO PREPARE AND MAINTAIN A STORM WATER POLLUTION PREVENTION PLAN IN ACCORDANCE WITH EPA AND STATE GUIDELINES AS REQUIRED BY LAW.

2. SURVEY CONTROL

- SURVEY PROVIDED BY SURVEYOR SCHERBEL LTD. UNDER A SEPARATE CONTRACT.
- HORIZONTAL DATUM IS IDAHO STATE PLANE NAD 83, EAST ZONE, US SURVEY FOOT.
- CONTRACTOR TO PROVIDE ALL CONSTRUCTION SURVEY REQUIRED FOR THE PROJECT.
- CONTRACTOR SHALL PRESERVE AND PROTECT ALL MONUMENT REFERENCE MARKS WITHIN AND AROUND THE PROJECT.

3. CONCRETE

- CONCRETE SHOULD BE INSTALLED IN ACCORDANCE WITH SPECIFICATION 03-3111, THE AMERICAN CONCRETE INSTITUTE (ACI), AND JOINT DETAILS SHOULD CONFORM TO THE PORTLAND CEMENT ASSOCIATION (PCS) GUIDELINES.
- FOR COMPRESSIVE STRENGTH AND MIX DESIGN REFER TO SPECIFICATION 03-3111.

COLD WEATHER CONCRETE REQUIREMENTS:

REQUIREMENTS FOR CONCRETE PLACEMENT DURING COLD WEATHER, PER SPECIFICATION 03-3111, INTERNATIONAL BUILDING CODE, AND AMERICAN CONCRETE INSTITUTE (ACI318). REFER TO SPECIFICATION FOR GOVERNING PROCEDURES.

4. SITE SOILS

- REFER TO THE FOLLOWING SPECIFICATIONS: 31-1100, 31-2323, AND 31-1123.
- ALL SURFICIAL LOOSE/DISTURBED SOILS OR NON-ENGINEERED FILLS (AS APPLICABLE) MUST BE REMOVED BELOW ALL FOOTINGS, FLOOR SLABS, AND RIGID PAVEMENTS. THE IN SITU, NON-ENGINEERED FILLS MAY REMAIN BELOW FLEXIBLE PAVEMENTS IF FREE OF ANY DELETERIOUS MATERIALS, OF LIMITED THICKNESS, AND IF PROPERLY PREPARED.
- PRIOR TO PROCEEDING WITH CONSTRUCTION, REMOVAL OF SURFACE VEGETATION, ROOT SYSTEMS, TOPSOIL, NON-ENGINEERED FILL, AND ANY DELETERIOUS MATERIALS FROM BENEATH AN AREA EXTENDING 5 FEET FROM THE PERIMETER OF THE PROPOSED STRUCTURE FOOTPRINT AND 3 FEET BEYOND RIGID PAVEMENTS AND EXTERIOR FLATWORK WILL BE REQUIRED. ADDITIONAL REQUIREMENTS IN SPECIFICATION 31-1100.
- FINE-GRAINED SOILS WILL REQUIRE VERY CLOSE MOISTURE CONTROL AND MAY BE VERY DIFFICULT IF NOT POSSIBLE, TO PROPERLY PLACE AND COMPACT DURING WET AND COLD PERIODS OF THE YEAR.
- SUBSEQUENT TO STRIPPING AND PRIOR TO PLACEMENT OF FLOOR SLAB, FOUNDATION, STRUCTURAL SITE GRADING FILLS, EXTERIOR FLATWORK, AND PAVEMENTS, THE EXPOSED SUBGRADE MUST BE PROOF ROLLED BY PASSING MODERATE-WEIGHT RUBBER TIRE MOUNTED CONSTRUCTION EQUIPMENT OVER THE SURFACE AT LEAST TWICE. IF EXCESSIVELY SOFT OR OTHERWISE UNSUITABLE SOILS ARE ENCOUNTERED BENEATH FOOTINGS, THEY MUST BE COMPLETELY REMOVED.
- A QUALIFIED TESTING TECHNICIAN SHALL VERIFY FLOOR SLABS, FOOTINGS, AND PAVEMENTS ARE FREE FROM LOOSE/DISTURBED SOILS AND NON-ENGINEERED SOIL.
- UNDER NO CIRCUMSTANCES SHALL FOUNDATIONS BE ESTABLISHED OVER NON-ENGINEERED FILLS, LOOSE OR DISTURBED SOIL, TOPSOIL, SURFACE VEGETATION, ROOT SYSTEMS, RUBBISH, CONSTRUCTION DEBRIS, OTHER DELETERIOUS MATERIALS, FROZEN SOILS, OR WITHIN POUNDED WATER.
- CRUSHED STONE SHOULD CONFORM TO APPLICABLE SECTIONS OF THE CURRENT ITD STANDARD SPECIFICATIONS.
- PROPER COMPACTION AND DENSITY TESTING SHALL BE PERFORMED PER OWNERS DIRECTION AND SPECIFICATIONS.
- REFER TO TESTING AND INSPECTION SPECIFICATIONS.

5. UTILITIES

- CONTRACTOR SHALL VERIFY THE EXACT LOCATION, SIZE, MATERIAL, AND ELEVATION OF ALL UTILITIES PRIOR TO CONSTRUCTION BY POT HOLING. REPORT ANY CONFLICTS TO THE ENGINEER.
- IF A CONFLICT ARISES RESULTING FROM THE CONTRACTOR NEGLECTING TO POTHOLE UTILITIES, THE CONTRACTOR IS TO RESOLVE THE CONFLICT WITHOUT ADDITIONAL COST OR CLAIM TO THE OWNER.
- THE CONTRACTOR SHALL NOT BURY ANY UTILITY UNTIL THE OWNER OR AUTHORIZING AGENCY APPROVES THE UTILITY IS INSTALLED SUCCESSFULLY IN THE OPINION OF THE AGENCY IN WRITING. THE CONTRACTOR SHALL BE REQUIRED TO EXCAVATE AND EXPOSE ALL WORK THAT IS NOT SATISFACTORY TO THE AUTHORITY AGENCY.
- PROTECT ENTRANCE FROM ALL DIRT AND FOREIGN OBJECTS FROM ENTERING THE EXISTING OR NEW PIPELINE AT ALL TIMES.
- USE CLEAN GRANULAR BACKFILL MATERIAL FREE FROM ROCKS, BRUSH, ORGANIC MATTER, TRASH AND LARGE STONES (3/4" INCH MAXIMUM SIZE) WITH LESS THAN 5% PASSING #200 SIEVE PER APWA 381.
- TRENCH BACKFILL AND BEDDING MATERIAL GRADATIONS MUST BE APPROVED BY ENGINEER PRIOR TO INSTALLATION PER APWA 381 STANDARDS.
- CONTRACTOR MUST PROTECT ALL EXISTING UTILITIES.
- CONTRACTOR TO COORDINATE ALL WORK OR POTENTIAL OUTAGES OF EXISTING UTILITIES WITH THE AFFECTED AGENCY AND FOLLOW REQUIRED NOTIFICATION.
- APPROXIMATE LOCATION OF EXISTING WATERLINES ARE SHOWN GRAPHICALLY ONLY THROUGHOUT THE PROJECT AREA. CONTRACTOR SHALL LOCATE EXISTING UTILITIES BOTH HORIZONTALLY AND VERTICALLY BY EXCAVATION AS REQUIRED FOR INSTALLATION OF PIPE LINE. LOCATING UTILITIES SHALL BE INCIDENTAL TO PROJECT.
- THE CONTRACTOR SHALL HAVE AN APPROVED SET OF IMPROVEMENT PLANS ON THE JOB SITE AT ALL TIMES.
- ALL ROCK REMOVAL, WASTE CONCRETE REMOVAL, AND DE-WATERING SHALL BE THE RESPONSIBILITY OF THE CONTRACTOR, AND COST SHALL BE INCIDENTAL TO THE PROJECT.
- CONTRACTOR SHALL HAVE SANITARY FACILITIES ON SITE.
- ALL MATERIALS AND COMPONENTS USED IN THE CONSTRUCTION OF DRINKING WATER SYSTEMS SHALL BE NSF 61 APPROVED.
- ALL INSTALLED WATER MAINS SHALL BE FLUSHED AND DISINFECTED ACCORDING TO IDAHO DEPARTMENT OF ENVIRONMENTAL QUALITY STANDARDS AND PRESSURE TESTED PER APWA STANDARDS.
- THE OWNER SHALL BE NOTIFIED 48 HOURS IN ADVANCE OF ANY DISINFECTION AND PRESSURE TESTING OPERATIONS.
- ALL FITTINGS FOR PVC C-900 PIPE SHALL BE CAST IRON OR DUCTILE IRON, AWWA C-110 CLASS 250.

6. WATER & SEWER

- WATER INSTALLATION SHALL FOLLOW ALL REQUIREMENTS OF THE DIVISION OF DRINKING WATER OF THE IDAHO DEPARTMENT OF ENVIRONMENTAL QUALITY, APWA SPECIFICATION 33-08-00, AWWA 605 AND THE OWNER'S STANDARDS.
- ALL THRUST BLOCKS SHALL BE PLACED PER DETAILS.
- HYDROSTATIC TEST ALL WATER LINES PER APWA SECTION 33-08-00.
- ALL WATER MATERIALS SHALL BE RATED FOR A MINIMUM OF 200 PSI.
- SEWER INSTALLATION SHALL FOLLOW ALL REQUIREMENTS OF SOUTHEAST IDAHO DEPARTMENT OF ENVIRONMENTAL QUALITY AND THE OWNER'S STANDARDS.
- ALL EXISTING WATER ACCESS AND SEWER MH RIM ELEVATIONS MUST BE MODIFIED TO MATCH NEW FINISHED GRADE AND ALL WATER AND SEWER APPURTENANCES IF APPLICABLE.
- ALL WATER AND SEWER TO BE AWWA PRESSURE CLASS C900 OR APPROVED EQUAL.

7. ELECTRICAL

- CONTRACTOR TO FOLLOW SIX-STATE ELECTRICAL REQUIREMENTS FOR ALL TRENCHING, GRADING, AND CONDUIT INSTALLATION OR OWNER'S SPECIFICATIONS FOR POWER.
- SEE ELECTRICAL SITE PLAN FOR INFORMATION ON POWER.

8. AS-BUILT

- DUE TO FACILITIES BEING FIELD LOCATED, IT IS HIGHLY RECOMMENDED THAT AN AS-BUILT SURVEY IS PERFORMED AT THE COMPLETION OF THE WORK TO UPDATE OWNER'S RECORDS.

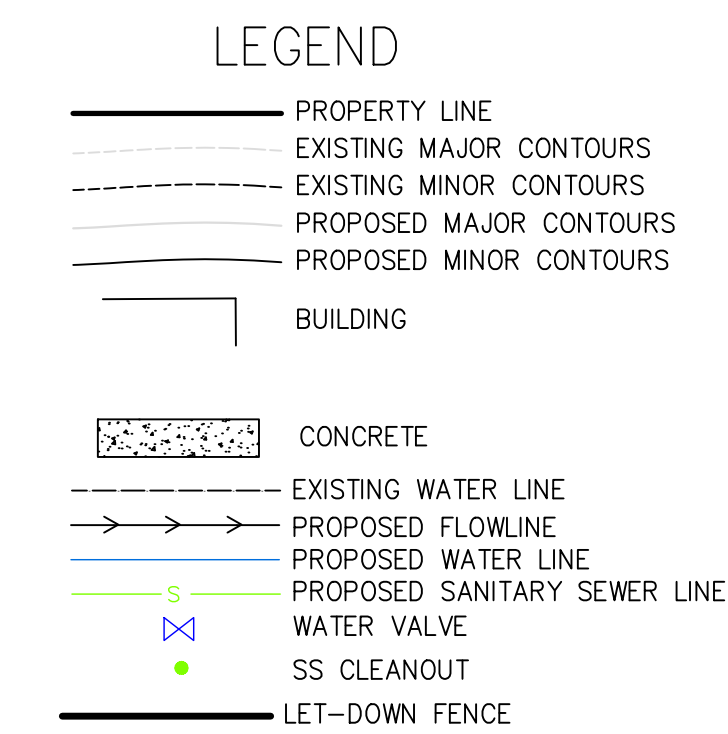

ABBREVIATION LIST

E	EASTING	PVC	POLY VINYL CHLORIDE	EG	EXISTING GRADE
EA	EACH	SS	SANITARY SEWER	FG	FINISHED GRADE
EX	EXISTING	SSMH	SANITARY SEWER MANHOLE	FS	FINISHED SURFACE
INV	INVERT	TYP.	TYPICAL		
LF	LINEAR FOOT	SPEC	SPECIFICATION		
MIN	MINIMUM	TYP.	TYPICAL		
N	NORTHING	FL	FLOWLINE		

STUDIO 333 ARCHITECTS
333 24TH STREET
OGDEN, UT 84401
801.394.3033

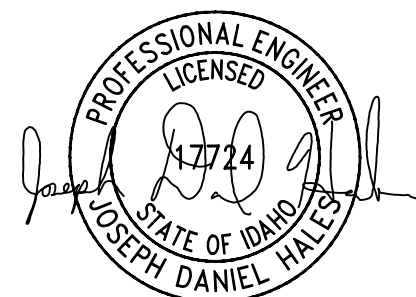

CAMP HULL VALLEY IMPROVEMENTS
10100 EAST CUB RIVER RD, PRESTON, IDAHO

HCF

NO.	DATE	DESCRIPTION

DATE: 03.15.23
PROJECT NUMBER: 06522
PROPERTY NUMBER: 501-737121050101

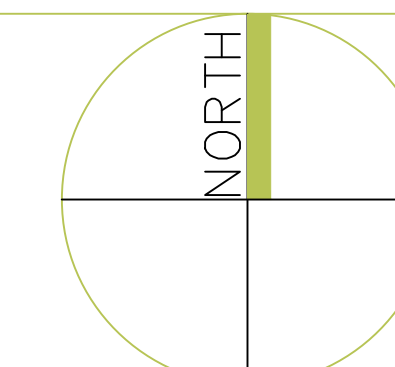

NOTES SHEET SHEET CG0.2

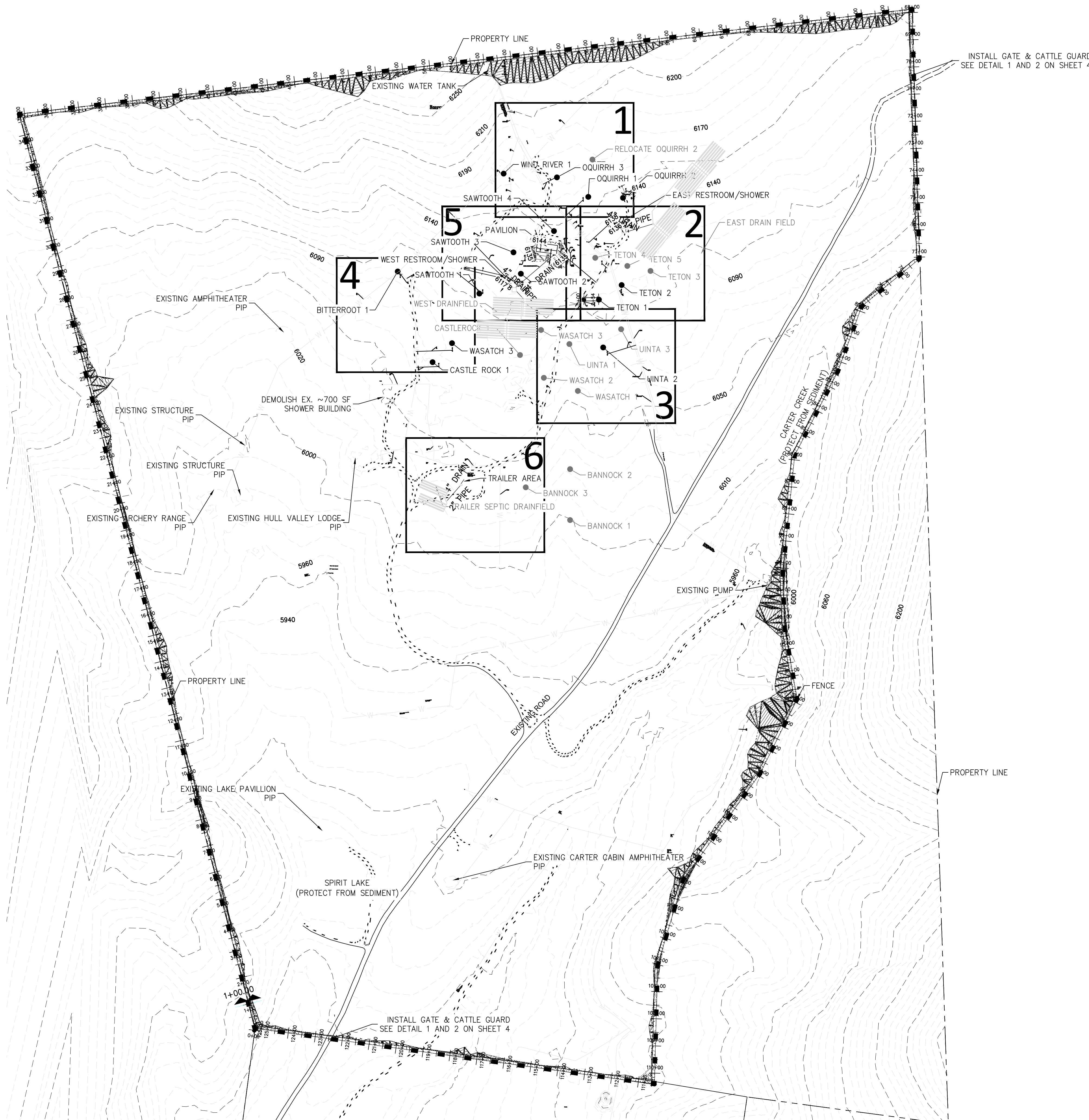

CAMP LEGEND:

- CAMP TO BE IMPROVED
- EX. CAMP, NOT IMPROVING

BASE BID:
TOTAL FENCE LENGTH: 12,530 LF

BID ALTERNATE 01:
TOTAL FENCE LENGTH (ALONG SOUTH PROPERTY): 11,052 LF+7,898 LF=18,950 LF
DIFF=6,420 LF

- NOTES:**
- CAMPSITES THAT ARE NOT BEING IMPROVED WERE NOT FIELD LOCATED AND ARE ONLY SHOWN AT APPROXIMATE LOCATIONS.
 - AVERAGE OF 5 TENT PADS, WITH APPROX. 4 PEOPLE PER TENT.
 - MAXIMUM CAMP CAPACITY IS 300 PEOPLE.
 - PROTECT TREES. MARK & VERIFY WITH OWNER PRIOR TO ANY TREES TO BE CUT.
 - REFER TO ARCHITECTURAL PLANS FOR BUILDING DETAILS.
 - REFER TO ELECTRICAL SITE PLAN FOR POWER.
 - ALL WATER LINES TO BE 25 FEET FROM SEPTIC DRAINFIELDS PER IDAPA 50.01.03.008.2D
 - PROVIDE A GATE VALVE ON EACH PROPOSED WATERLINE APPROXIMATELY FIVE FEET BEYOND CONNECTION AND STUB AT TERMINATION POINT.
 - GRADE 2% AWAY FROM ALL BUILDINGS
 - GRADE AROUND FACILITIES SO THAT WATER WILL BE PERMANENTLY DIVERTED AROUND.

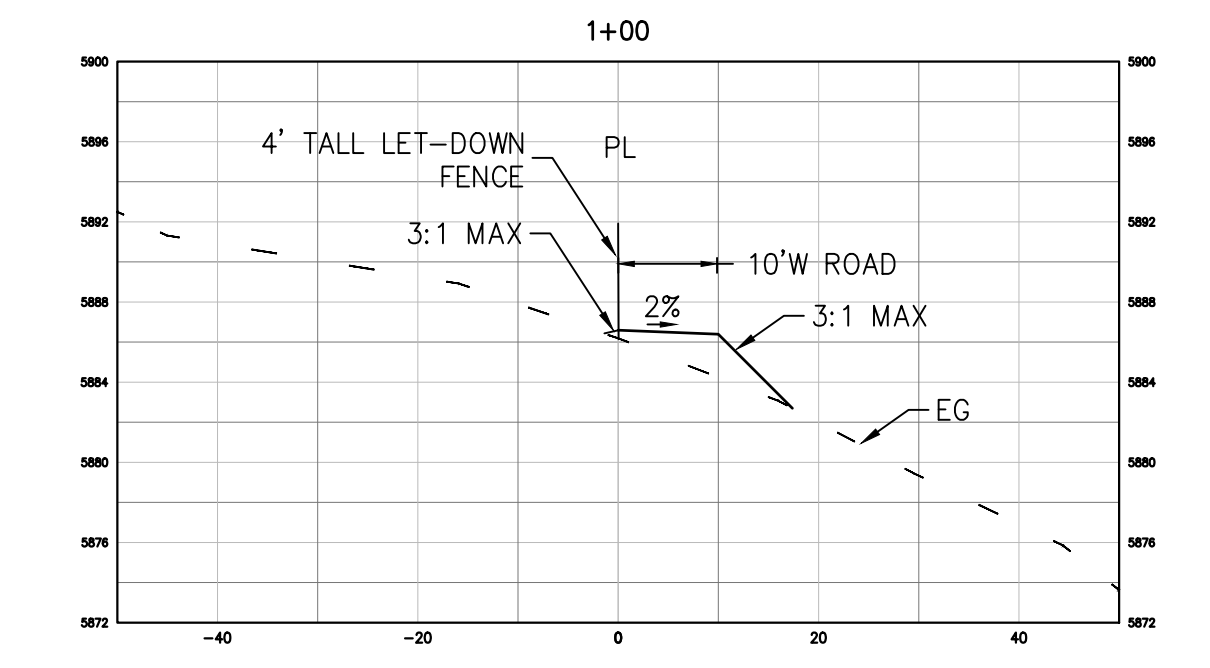

TYPICAL FENCE DETAIL NTS

STUDIO 333 ARCHITECTS
333 24TH STREET
OGDEN, UT 84401
801.394.3033

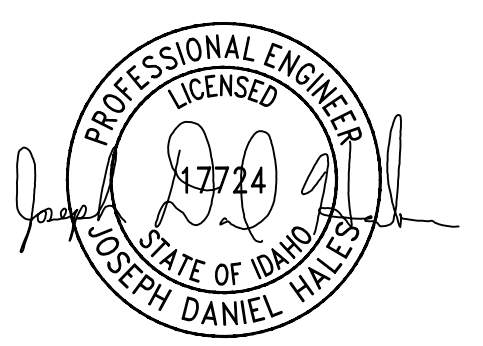

CAMP HULL VALLEY IMPROVEMENTS
10100 EAST CUB RIVER RD, PRESTON, IDAHO



NO.	DATE	DESCRIPTION

DATE: 03.15.23
PROJECT NUMBER: 06522
PROPERTY NUMBER: 501-737121050101
SCALE: 1" = 200'

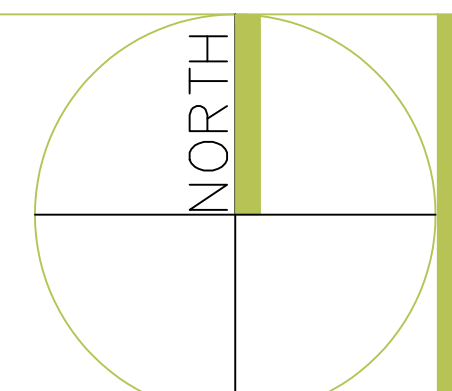

OVERALL SITE PLAN

SHEET CG0.3

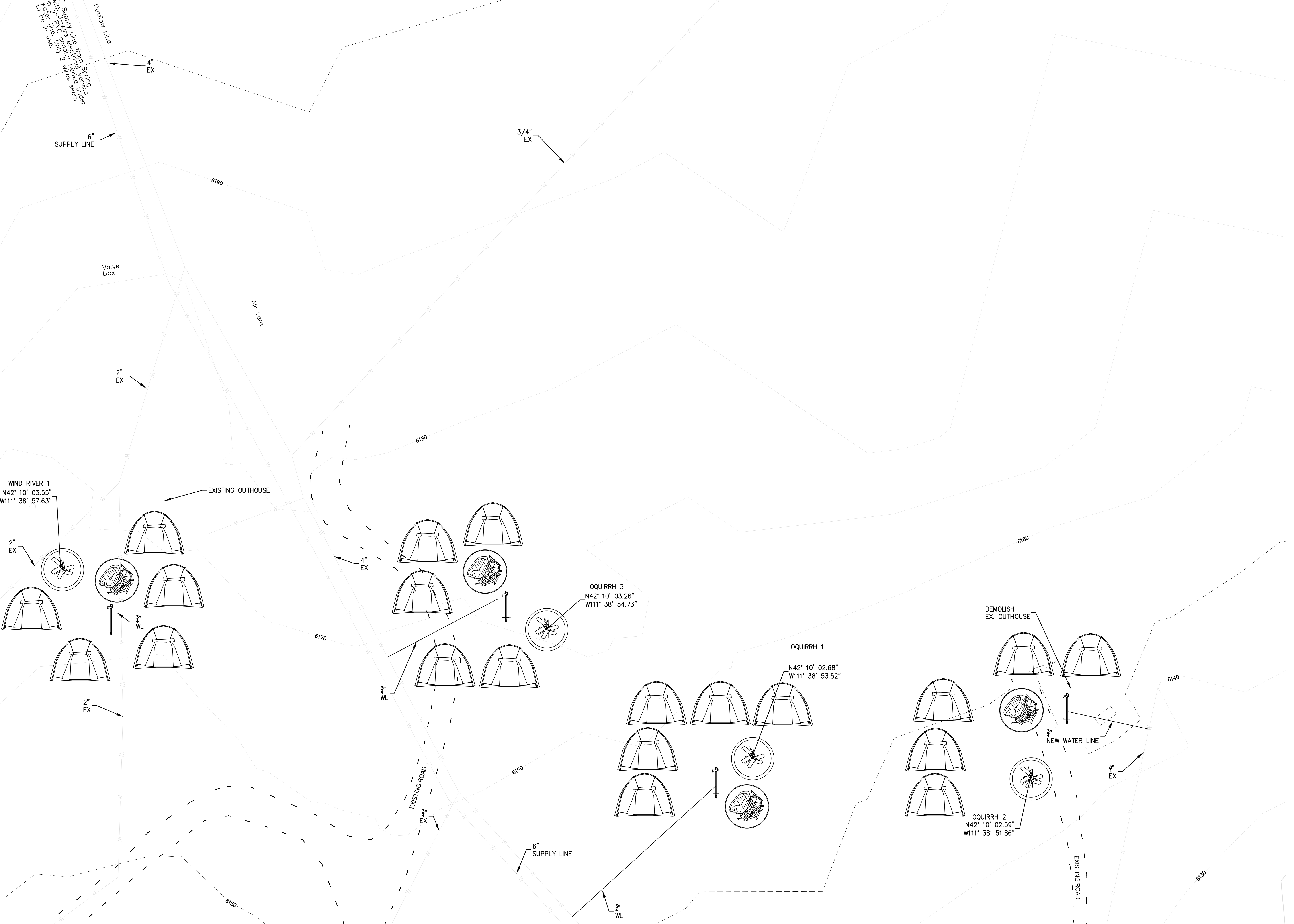

- NOTE:**
1. LEGEND ITEMS SHOWN FOR GRAPHICAL PURPOSES ONLY AND DO NOT REPRESENT ACTUAL LOCATIONS. ITEMS WILL BE FIELD LOCATED TO PRESERVE TREES AND FOR OTHER PURPOSES.
 2. PLACE 4" MINIMUM STRUCTURAL FILL OVER COMPACTED SUBGRADE FOR ALL SLAB ON GRADE BUILDINGS.
 3. POWER & WATER WILL BE EXTENDED TO EACH IMPROVED CAMPSITE.
 4. REFER TO ARCHITECTURAL DRAWINGS FOR BUILDING STRUCTURES.
 5. REFER TO ELECTRICAL DRAWINGS FOR ELECTRICAL DETAILS.

- CAMP LEGEND**
- 22.5'X22.5' DINING SHELTER
 - TENT PAD SITE SEE DETAIL 1 ON SHEET CD5.1
 - FIRE RING SEE DETAIL 1 ON SHEET CD2.1

STUDIO 333 ARCHITECTS
 333 24TH STREET
 OGDEN, UT 84401
 801.394.3033

CAMP HULL VALLEY IMPROVEMENTS
 10100 EAST CUB RIVER RD, PRESTON, IDAHO



NO.	DATE	DESCRIPTION

DATE: 03.15.23
 PROJECT NUMBER: 06522
 PROPERTY NUMBER: 501-737121050101
 SCALE: 1" = 20'

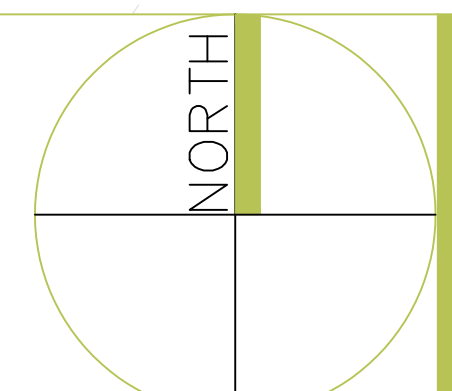

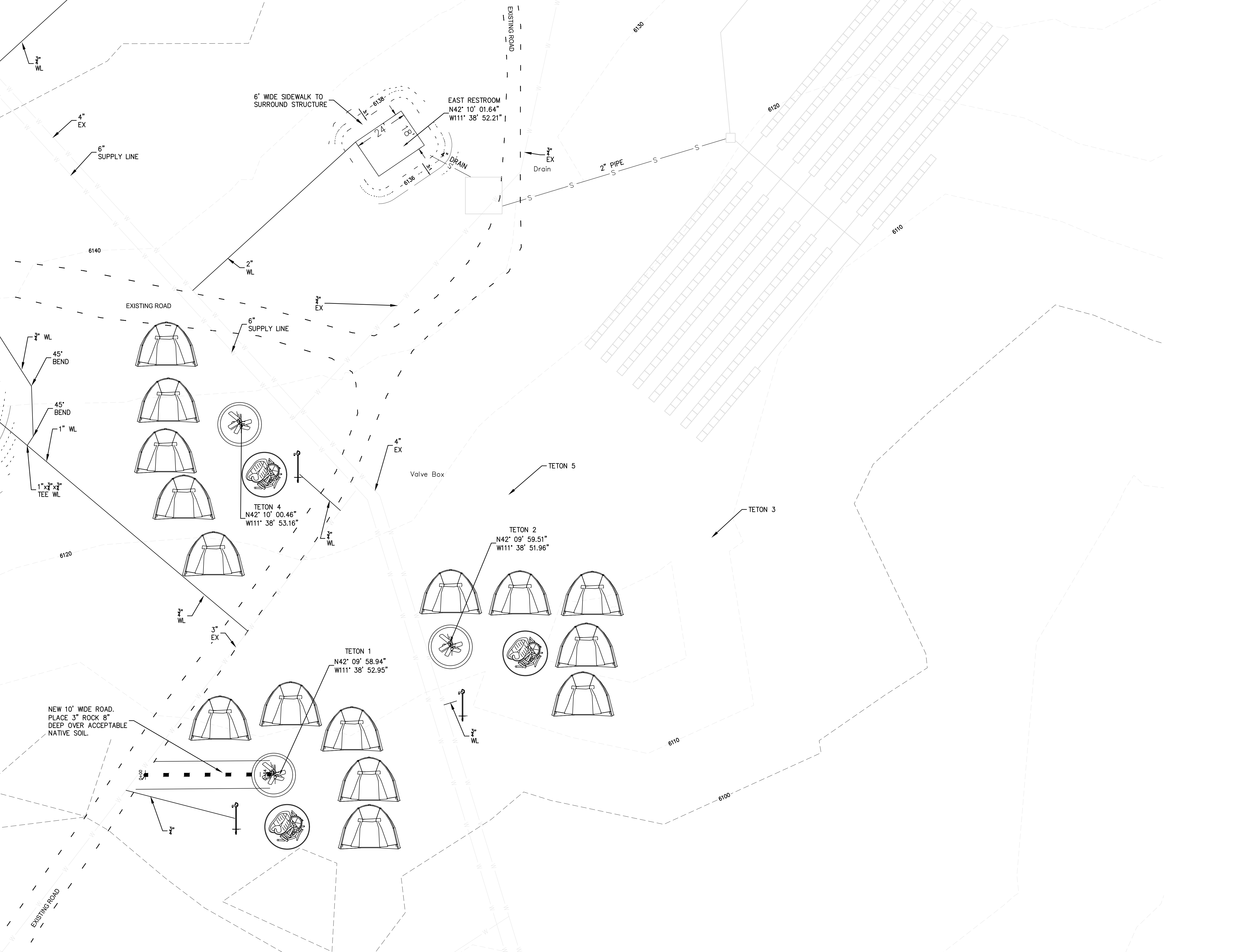

- NOTE:**
1. LEGEND ITEMS SHOWN FOR GRAPHICAL PURPOSES ONLY AND DO NOT REPRESENT ACTUAL LOCATIONS. ITEMS WILL BE FIELD LOCATED TO PRESERVE TREES AND FOR OTHER PURPOSES.
 2. PLACE 4" MINIMUM STRUCTURAL FILL OVER COMPACTED SUBGRADE FOR ALL SLAB ON GRADE BUILDINGS.
 3. POWER & WATER WILL BE EXTENDED TO EACH IMPROVED CAMPSITE.
 4. REFER TO ARCHITECTURAL DRAWINGS FOR BUILDING STRUCTURES.
 5. REFER TO ELECTRICAL DRAWINGS FOR ELECTRICAL DETAILS.

CAMP LEGEND

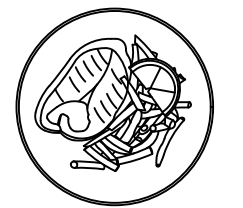
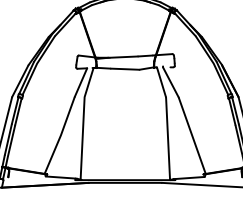
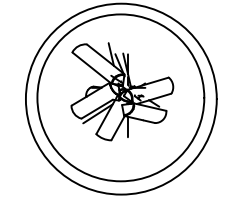
-  22.5'X22.5' DINING SHELTER
-  TENT PAD SITE SEE DETAIL 1 ON SHEET CD5.1
-  FIRE RING SEE DETAIL 1 ON SHEET CD2.1

STUDIO 333 ARCHITECTS
 333 24TH STREET
 OGDEN, UT 84401
 801.394.3033

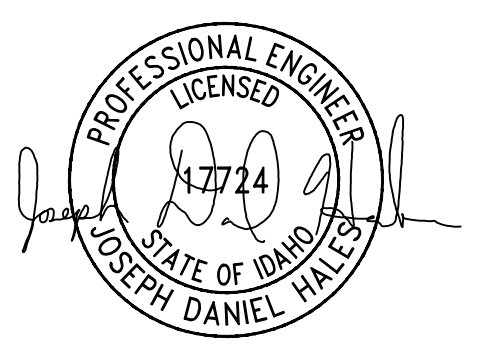

CAMP HULL VALLEY IMPROVEMENTS
 10100 EAST CUB RIVER RD, PRESTON, IDAHO



NO.	DATE	DESCRIPTION

DATE: 03.15.23
 PROJECT NUMBER: 06522
 PROPERTY NUMBER: 501-737121050101
 SCALE: 1" = 20'

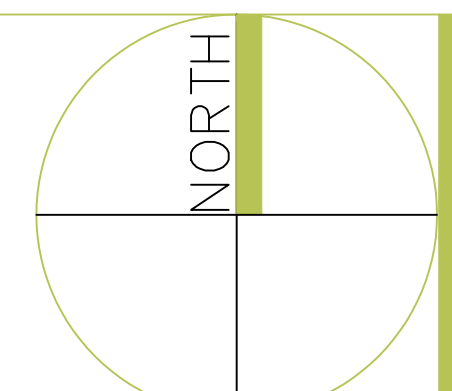



NOTE:

1. LEGEND ITEMS SHOWN FOR GRAPHICAL PURPOSES ONLY AND DO NOT REPRESENT ACTUAL LOCATIONS. ITEMS WILL BE FIELD LOCATED TO PRESERVE TREES AND FOR OTHER PURPOSES.
2. PLACE 4" MINIMUM STRUCTURAL FILL OVER COMPACTED SUBGRADE FOR ALL SLAB ON GRADE BUILDINGS.
3. POWER & WATER WILL BE EXTENDED TO EACH IMPROVED CAMPSITE.
4. REFER TO ARCHITECTURAL DRAWINGS FOR BUILDING STRUCTURES.
5. REFER TO ELECTRICAL DRAWINGS FOR ELECTRICAL DETAILS.

CAMP LEGEND

-  22.5'X22.5' DINING SHELTER
-  TENT PAD SITE SEE DETAIL 1 ON SHEET CD5.1
-  FIRE RING SEE DETAIL 1 ON SHEET CD2.1

STUDIO 333 ARCHITECTS
333 24TH STREET
OGDEN, UT 84401
801.394.3033

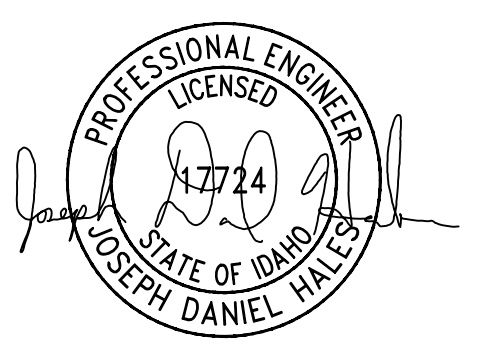

CAMP HULL VALLEY IMPROVEMENTS
10100 EAST CUB RIVER RD, PRESTON, IDAHO



NO.	DATE	DESCRIPTION

DATE: 03.15.23
PROJECT NUMBER: 06522
PROPERTY NUMBER: 501-737121050101
SCALE: 1" = 20'

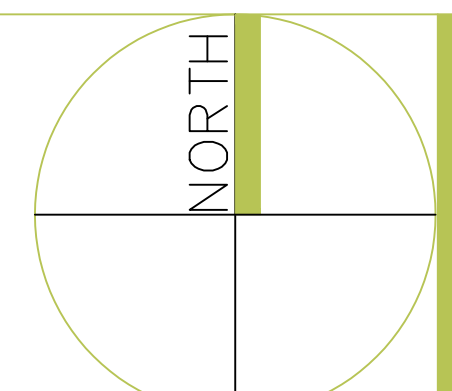

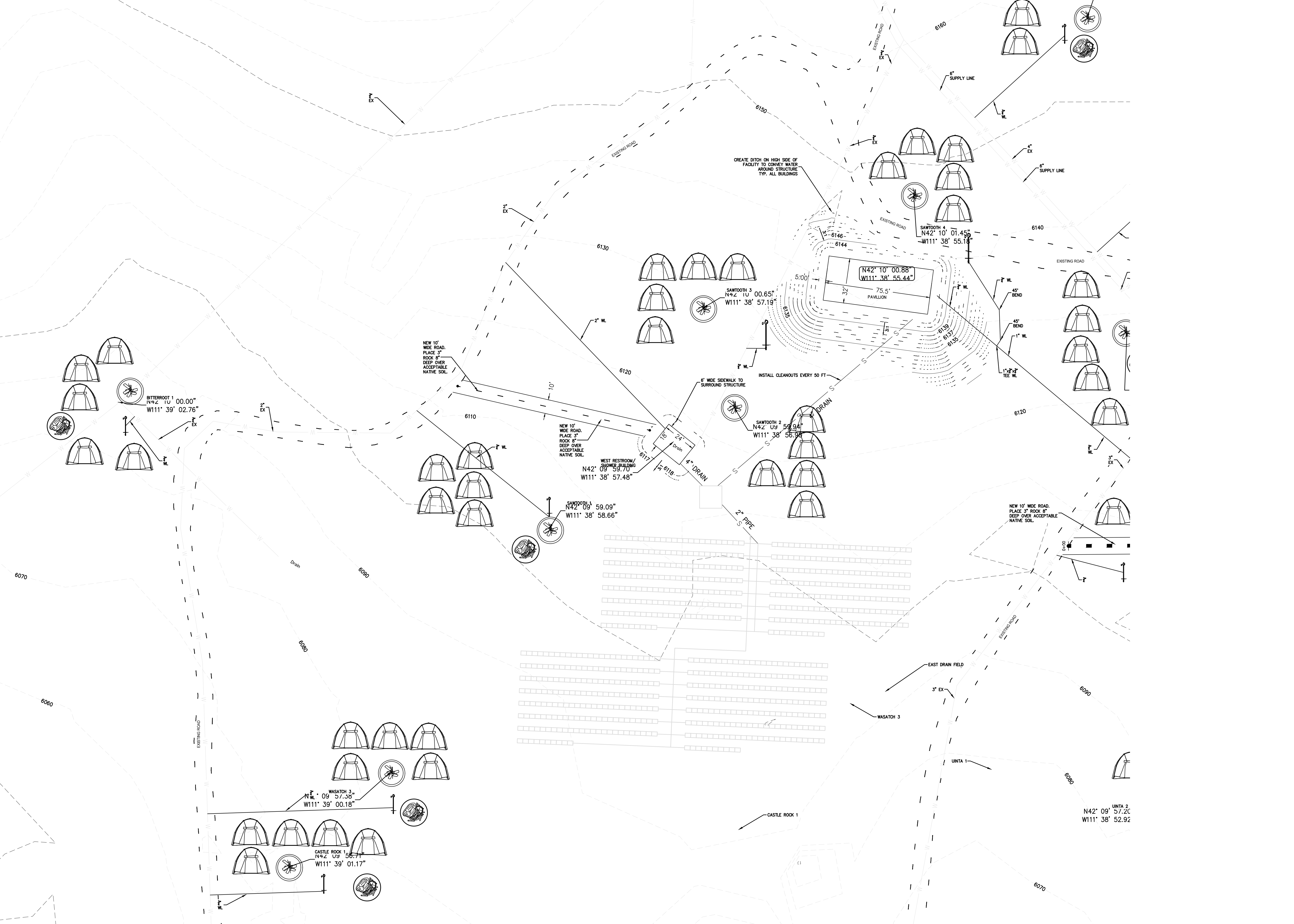

NOTE:

1. LEGEND ITEMS SHOWN FOR GRAPHICAL PURPOSES ONLY AND DO NOT REPRESENT ACTUAL LOCATIONS. ITEMS WILL BE FIELD LOCATED TO PRESERVE TREES AND FOR OTHER PURPOSES.
2. PLACE 4" MINIMUM STRUCTURAL FILL OVER COMPACTED SUBGRADE FOR ALL SLAB ON GRADE BUILDINGS.
3. POWER & WATER WILL BE EXTENDED TO EACH IMPROVED CAMPSITE.
4. REFER TO ARCHITECTURAL DRAWINGS FOR BUILDING STRUCTURES.
5. REFER TO ELECTRICAL DRAWINGS FOR ELECTRICAL DETAILS.

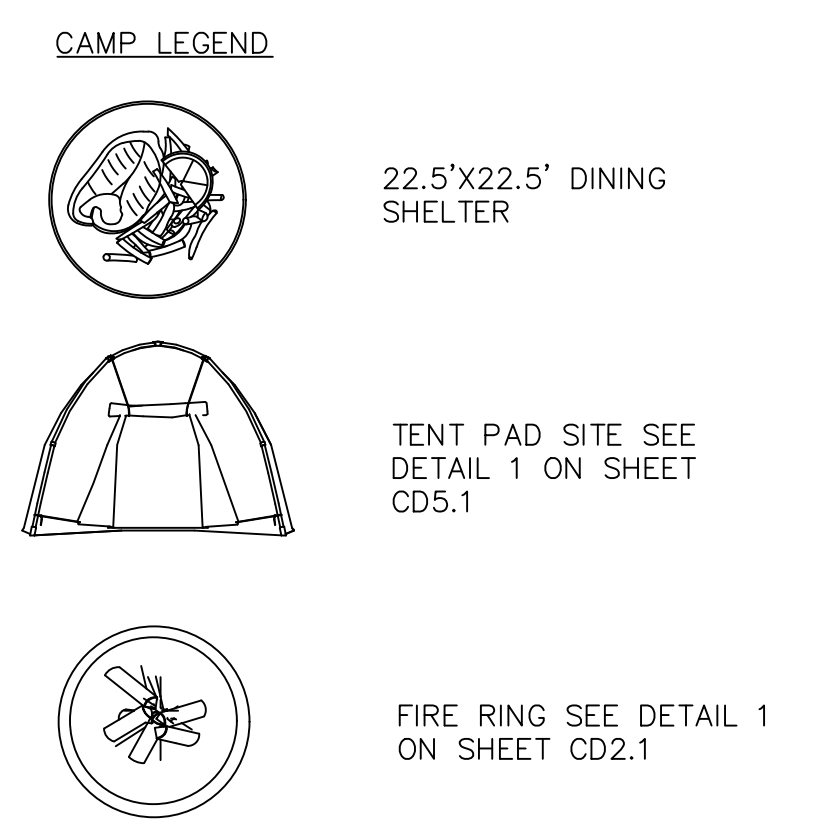

STUDIO 333 ARCHITECTS
333 24TH STREET
OGDEN, UT 84401
801.394.3033

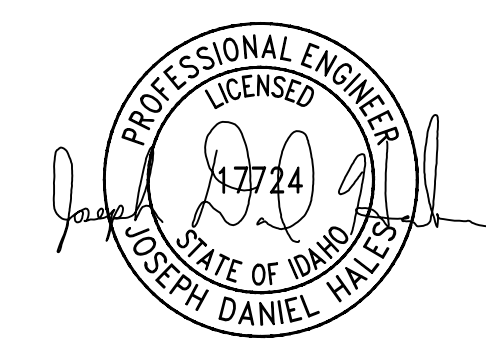

CAMP HULL VALLEY IMPROVEMENTS
10100 EAST CUB RIVER RD, PRESTON, IDAHO



NO.	DATE	DESCRIPTION

DATE: 03.15.23
PROJECT NUMBER: 06522
PROPERTY NUMBER: 501-737121050101
SCALE: 1" = 20'

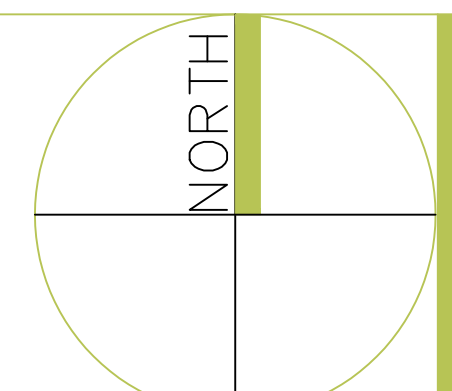

SITE PLAN
AREA 5
SHEET C5.1

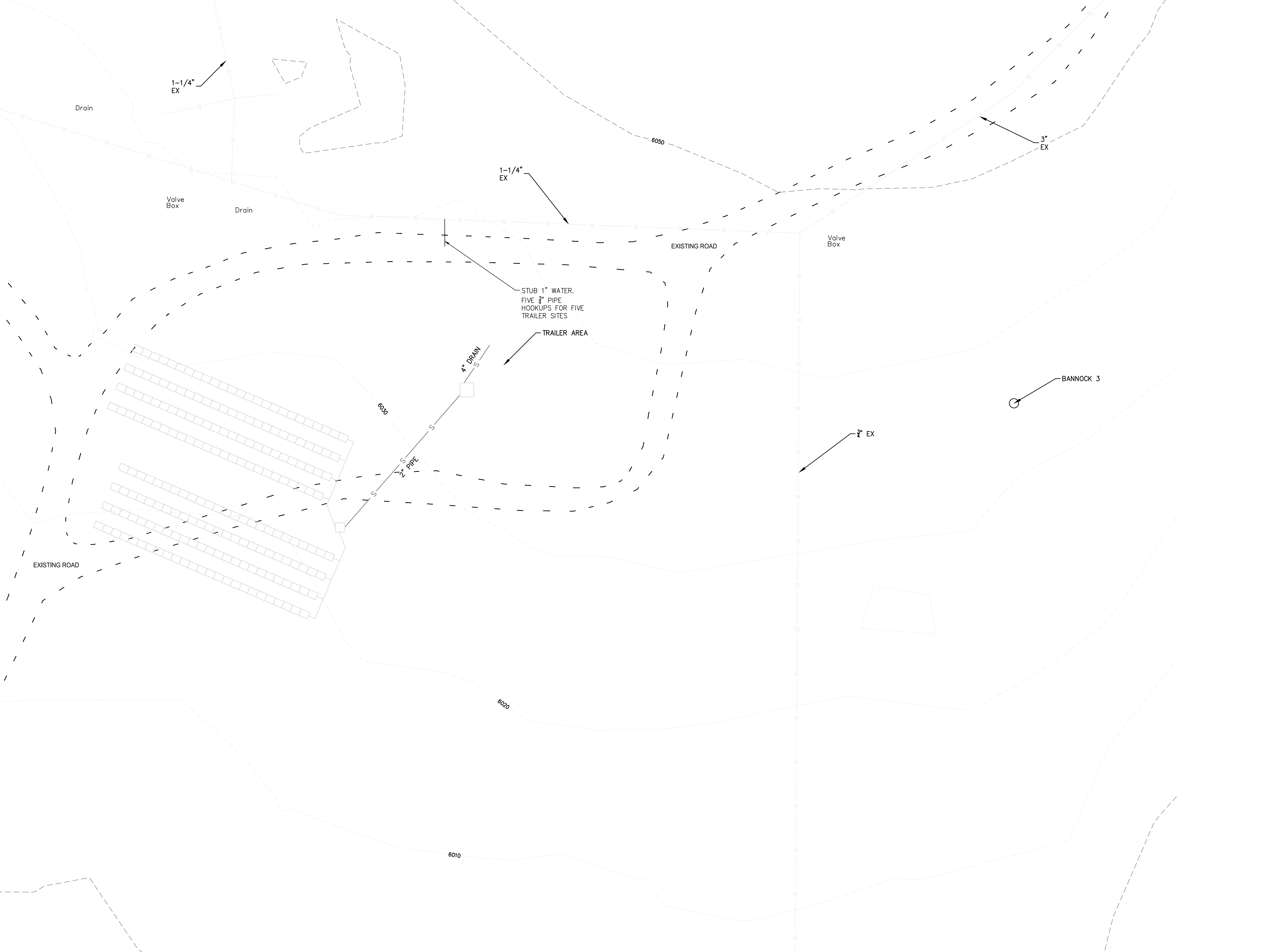

- NOTE:**
1. LEGEND ITEMS SHOWN FOR GRAPHICAL PURPOSES ONLY AND DO NOT REPRESENT ACTUAL LOCATIONS. ITEMS WILL BE FIELD LOCATED TO PRESERVE TREES AND FOR OTHER PURPOSES.
 2. PLACE 4" MINIMUM STRUCTURAL FILL OVER COMPACTED SUBGRADE FOR ALL SLAB ON GRADE BUILDINGS.
 3. POWER & WATER WILL BE EXTENDED TO EACH IMPROVED CAMPSITE.
 4. REFER TO ARCHITECTURAL DRAWINGS FOR BUILDING STRUCTURES.
 5. REFER TO ELECTRICAL DRAWINGS FOR ELECTRICAL DETAILS.

CAMP LEGEND

-  22.5'X22.5' DINING SHELTER
-  TENT PAD SITE SEE DETAIL 1 ON SHEET CD5.1
-  FIRE RING SEE DETAIL 1 ON SHEET CD2.1

STUDIO 333 ARCHITECTS
 333 24TH STREET
 OGDEN, UT 84401
 801.394.3033

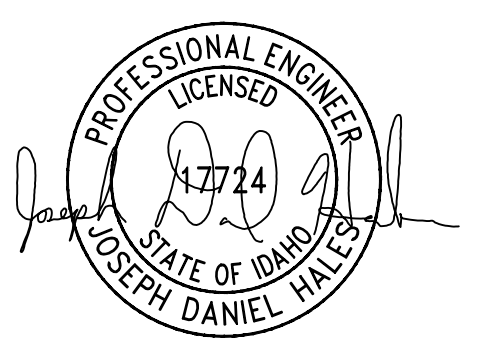

CAMP HULL VALLEY IMPROVEMENTS
 10100 EAST CUB RIVER RD, PRESTON, IDAHO



NO.	DATE	DESCRIPTION

DATE: 03.15.23
 PROJECT NUMBER: 06522
 PROPERTY NUMBER: 501-737121050101
 SCALE: 1" = 20'

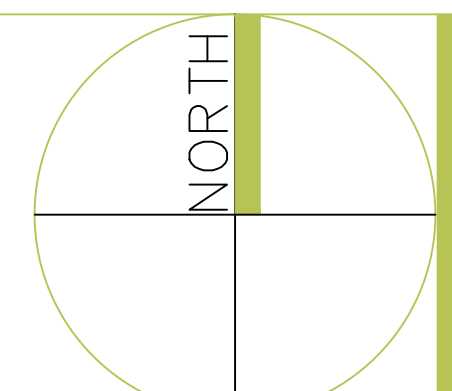

- NOTES:**
- INFILTRATOR CHAMBERS QUICK4 PLUS SERIES. DAILY DESIGN FLOW IS 5500 GAL/DAY.
 - 12" MIN. COVER. TRENCH WIDTH SHALL BE 36". MAX SLOPE OF 20%. INSTALL PER MANUFACTURER SPECIFICATIONS.
 - DRAINFIELD SIZE IS BASED ON INFILTRATORS BEING PLACED IN "B" GRADE SOILS.
 - RESTROOM SITE IS APPROVED FOR CONSTRUCTION AT A MAX DEPTH OF 2'. EXCAVATE ~2170 CUBIC YARDS OF SOIL - BASED ON DEPTH OF 2'.
 - REMOVE ~85 TREES - BASED ON 1 TREE PER CIRCLE OF 9' RADIUS.

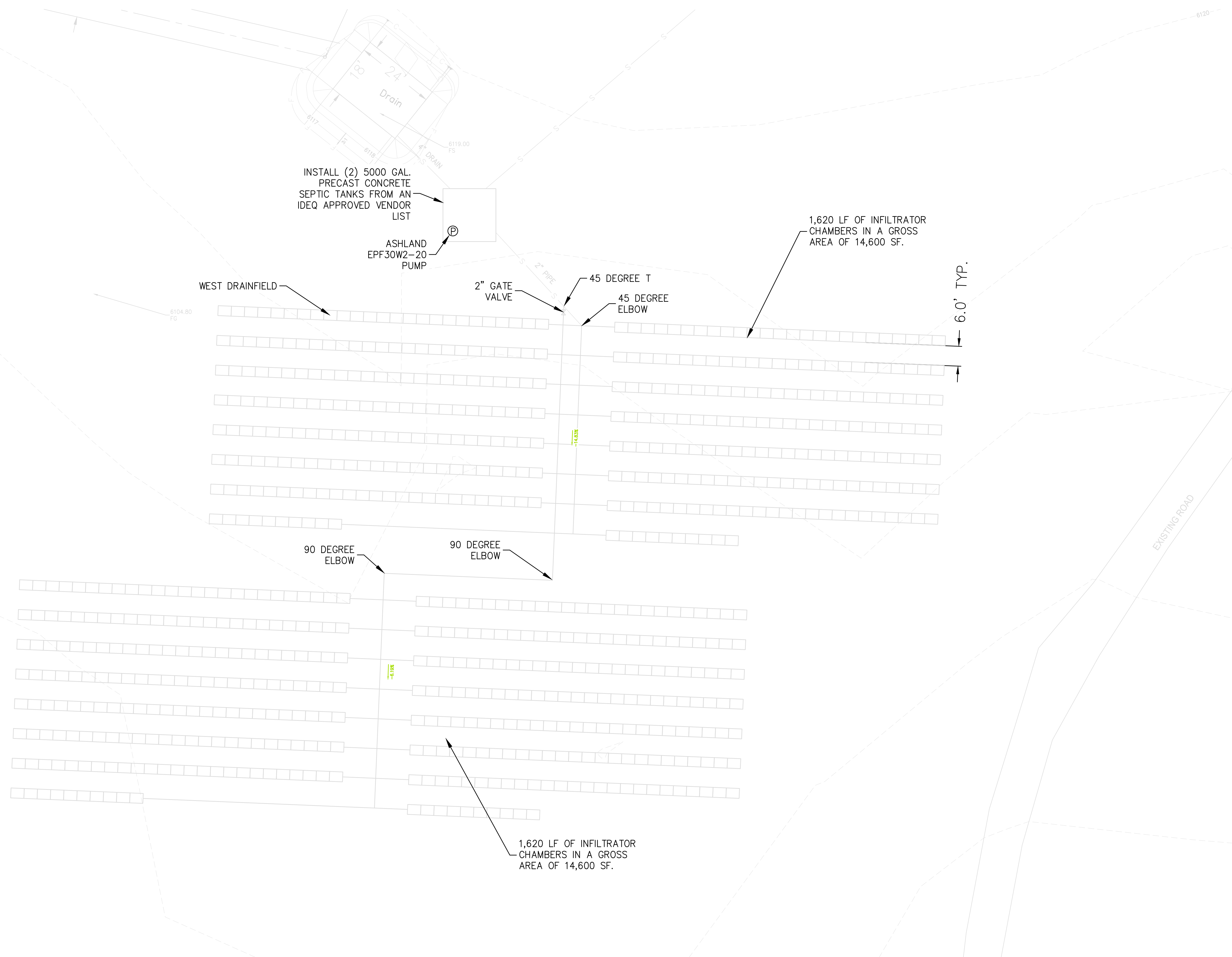

100% FOR BID ONLY, NOT FOR CONSTRUCTION

STUDIO 333 ARCHITECTS
333 24TH STREET
OGDEN, UT 84401
801.394.3033

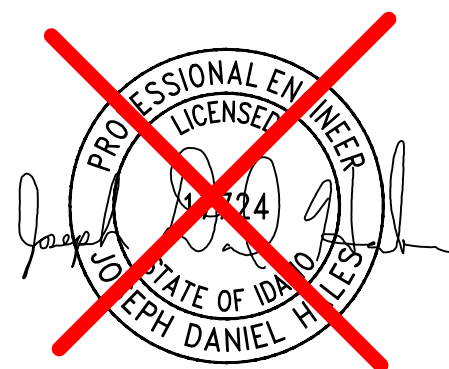

CAMP HULL VALLEY IMPROVEMENTS
10100 EAST CUB RIVER RD, PRESTON, IDAHO



NO.	DATE	DESCRIPTION

DATE: 03.15.23
PROJECT NUMBER: 06522
PROPERTY NUMBER: 501-737121050101
SCALE: 1" = 15'

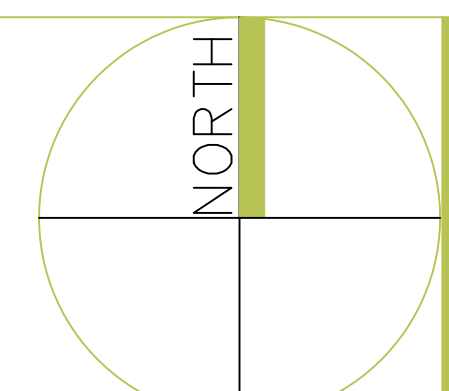

WEST RESTROOM SEPTIC PLAN SHEET SP7.1

- NOTES:**
- INFILTRATOR CHAMBERS QUICK4 PLUS SERIES. DAILY DESIGN FLOW IS 5500 GAL/DAY.
 - 12" MIN. COVER. TRENCH WIDTH SHALL BE 36". MAX SLOPE OF 20%. INSTALL PER MANUFACTURER SPECIFICATIONS.
 - DRAINFIELD SIZE IS BASED ON INFILTRATORS BEING PLACED IN "B" GRADE SOILS.
 - RESTROOM SITE IS APPROVED FOR CONSTRUCTION 2'-3' BELOW GRADE.
 - EXCAVATE ~3240 CUBIC YARDS OF SOIL - BASED ON DEPTH OF 3'.
 - REMOVE ~95 TREES - BASED ON 1 TREE PER CIRCLE OF 9' RADIUS.

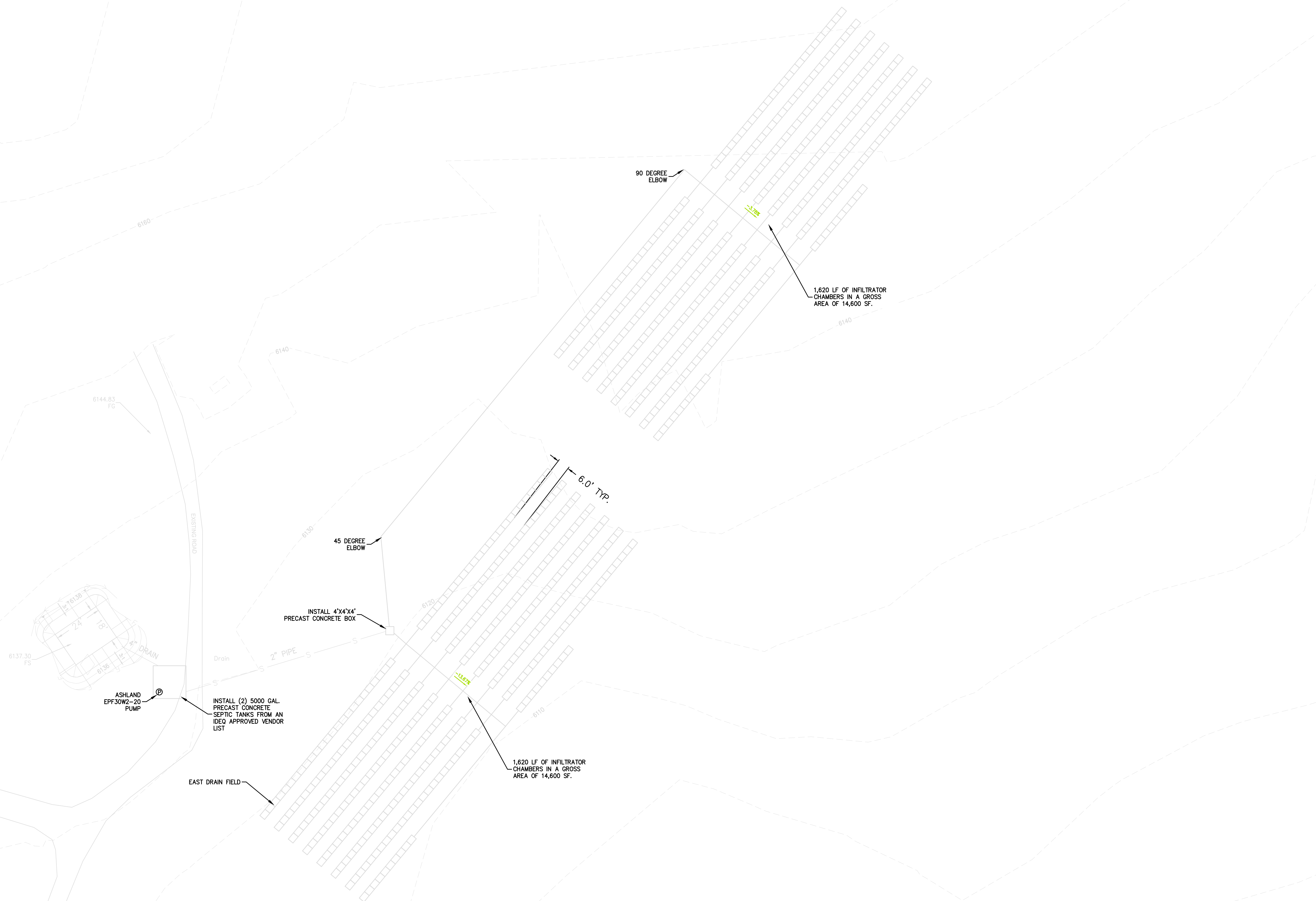

100% FOR BID ONLY, NOT FOR CONSTRUCTION

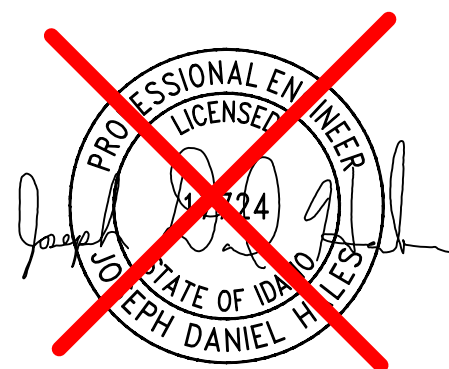

NO.	DATE	DESCRIPTION

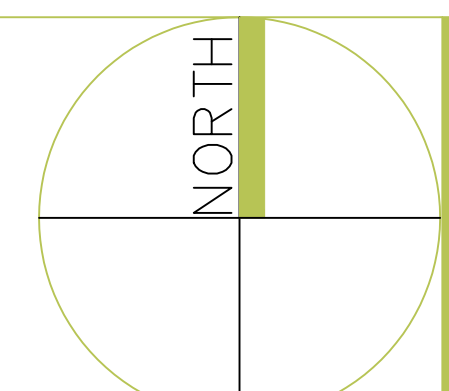

- NOTES:**
- INFILTRATOR CHAMBERS QUICK4 PLUS SERIES. DAILY DESIGN FLOW IS 725 GAL/DAY.
 - 12" MIN. COVER. TRENCH WIDTH SHALL BE 36". MAX SLOPE OF 20%. INSTALL PER MANUFACTURER SPECIFICATIONS.
 - TRAILER SITE IS APPROVED FOR CONSTRUCTION 2'-4' BELOW GRADE.
 - EXCAVATE ~3000 CUBIC YARDS OF SOIL - BASED ON DEPTH OF 3'.
 - REMOVE ~5 TREES - BASED ON 1 TREE PER CIRCLE OF 9' RADIUS.

300 LF OF INFILTRATOR CHAMBERS IN A GROSS AREA OF 3,000 SF.
TRAILER SEPTIC DRAINFIELD

STUB 1" WATER. FIVE 3/4" PIPE HOOKUPS FOR FIVE TRAILER SITES

INSTALL 1500 GAL. PRECAST CONCRETE SEPTIC TANK FROM AN IDEQ APPROVED VENDOR LIST

ASHLAND EPF30W2-20 PUMP

INSTALL 4'X4'X4' PRECAST CONCRETE BOX

45 DEGREE ELBOW

45 DEGREE ELBOW

300 LF OF INFILTRATOR CHAMBERS IN A GROSS AREA OF 3,000 SF.

EXISTING ROAD

100% FOR BID ONLY, NOT FOR CONSTRUCTION

STUDIO 333 ARCHITECTS
333 24TH STREET
OGDEN, UT 84401
801.394.3033

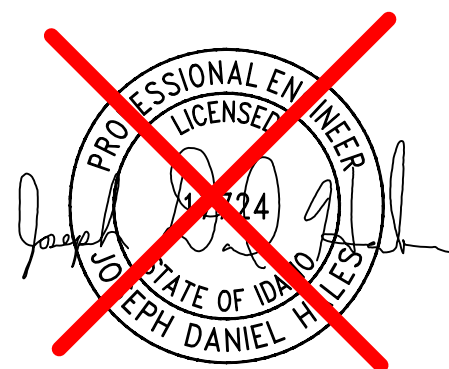

CAMP HULL VALLEY IMPROVEMENTS
10100 EAST CUB RIVER RD, PRESTON, IDAHO



NO.	DATE	DESCRIPTION

DATE: 03.15.23
PROJECT NUMBER: 06522
PROPERTY NUMBER: 501-737121050101
SCALE: 1" = 10'

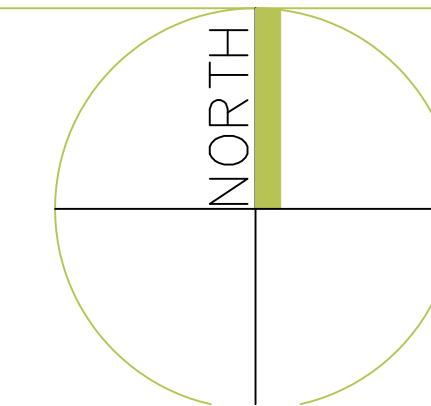

TRAILER SEPTIC PLAN

SHEET SP9.1

- REQUIREMENTS:
- OWNER/STAFF WILL NEED TO RAISE THE LET-DOWN FENCE PRIOR TO GRAZING SEASON AND LOWER IT PRIOR TO WINTER MONTHS.
 - REFER TO SPECIFICATION FOR STRUCTURAL RANGE, GENERAL TECHNICAL REPORT PNW-GTR-250 SEPTEMBER 1990
 - CONTRACTOR TO ENSURE THE TENSION-CABLE ANCHOR SUFFICIENTLY SUPPORTS THE SPAN THAT WILL BE LET DOWN, PER SPECIFICATION. THE ANCHOR CAN BE FASTENED TO A TREE OR TO A PERMANENT FENCELINE BRACE (FIG. 26), IF APPROVED BY OWNER IN WRITING.
 - LET-DOWN-FENCE SPANS SHALL BE PLANNED AS STRAIGHT STRETCHES. POSTS MAY BE WOOD OR STEEL PER OWNER'S DIRECTION. LINE POSTS SHALL BE SPACED AT A MAXIMUM OF 30 FEET, WITH TWO OR THREE WOODEN STAYS FOR ANY SPAN OVER 15 FEET. LINE BRACES SHALL BE SET AT A MINIMUM DISTANCE OF 180 FEET.
 - CONSTRUCTION SHALL ALLOW EACH SECTION BETWEEN ANCHOR POINTS TO BE LAID DOWN.
 - WIRE STRANDS SHOULD NOT BE STRETCHED AS TIGHTLY AS IN REGULAR POST-AND-WIRE FENCES. WIRE SUPPORTS CAN BE USED ON TREE NAILERS OR ROCK, AS DIRECTED BY OWNER.

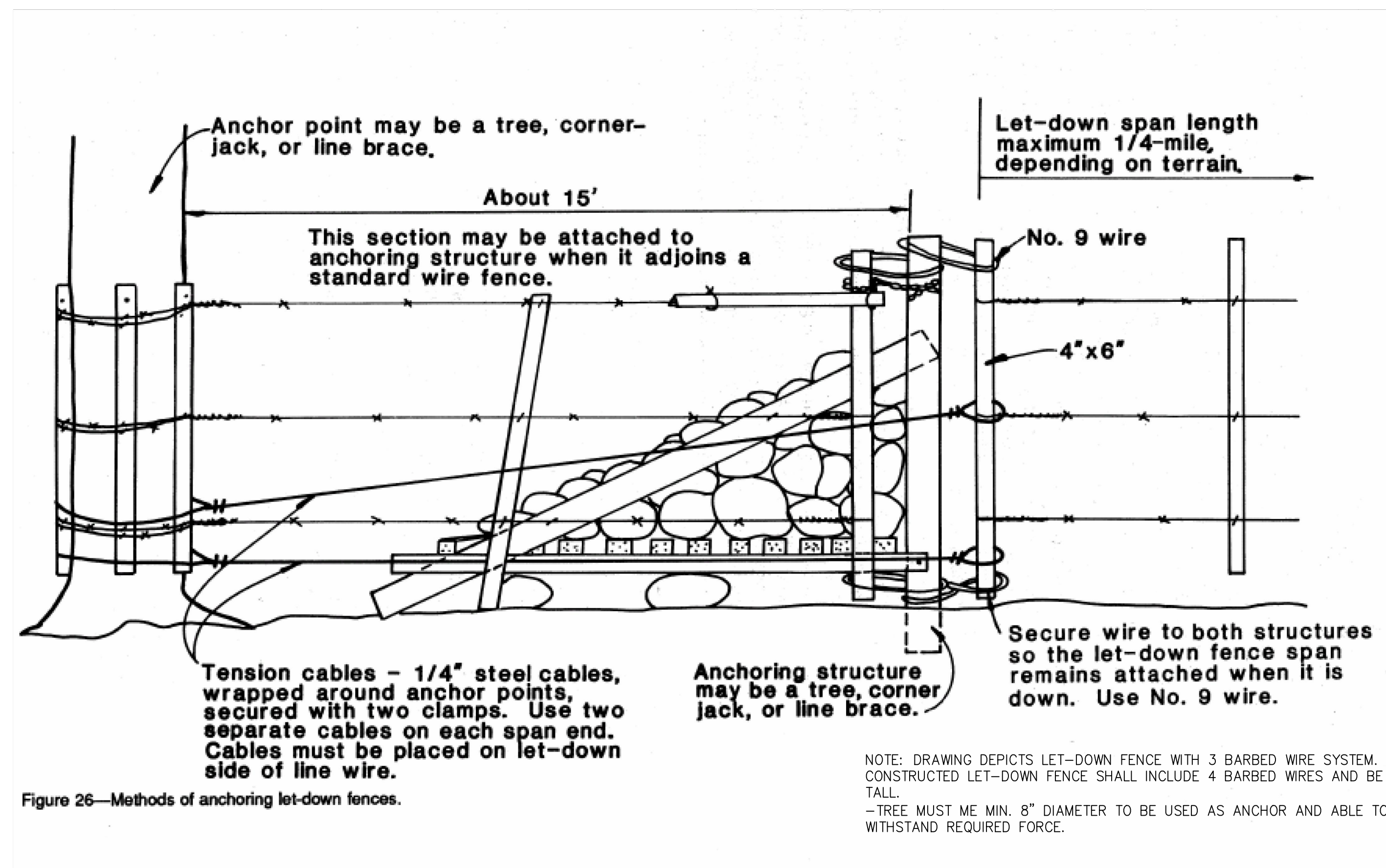

39

1 LET DOWN FENCE DETAIL
NOT TO SCALE

NO.	DATE	DESCRIPTION

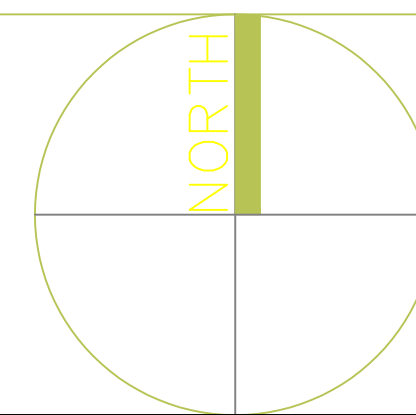

3' BY 1' GALVANIZED STEEL TARTER
FIRE RING ANCHORED FOR SAFETY.
ANCHOR FIRE PIT IN GROUND STABILIZE
WITH 18" METAL STAKES.

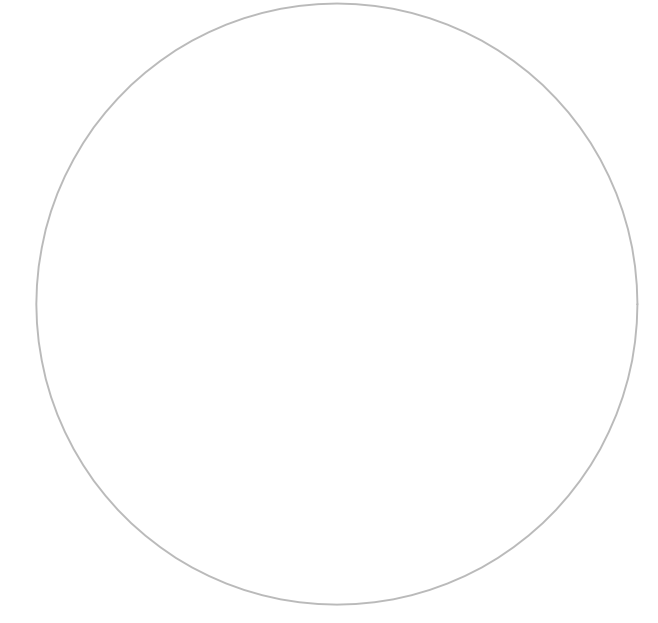

1 FIRE PIT DETAIL
NOT TO SCALE

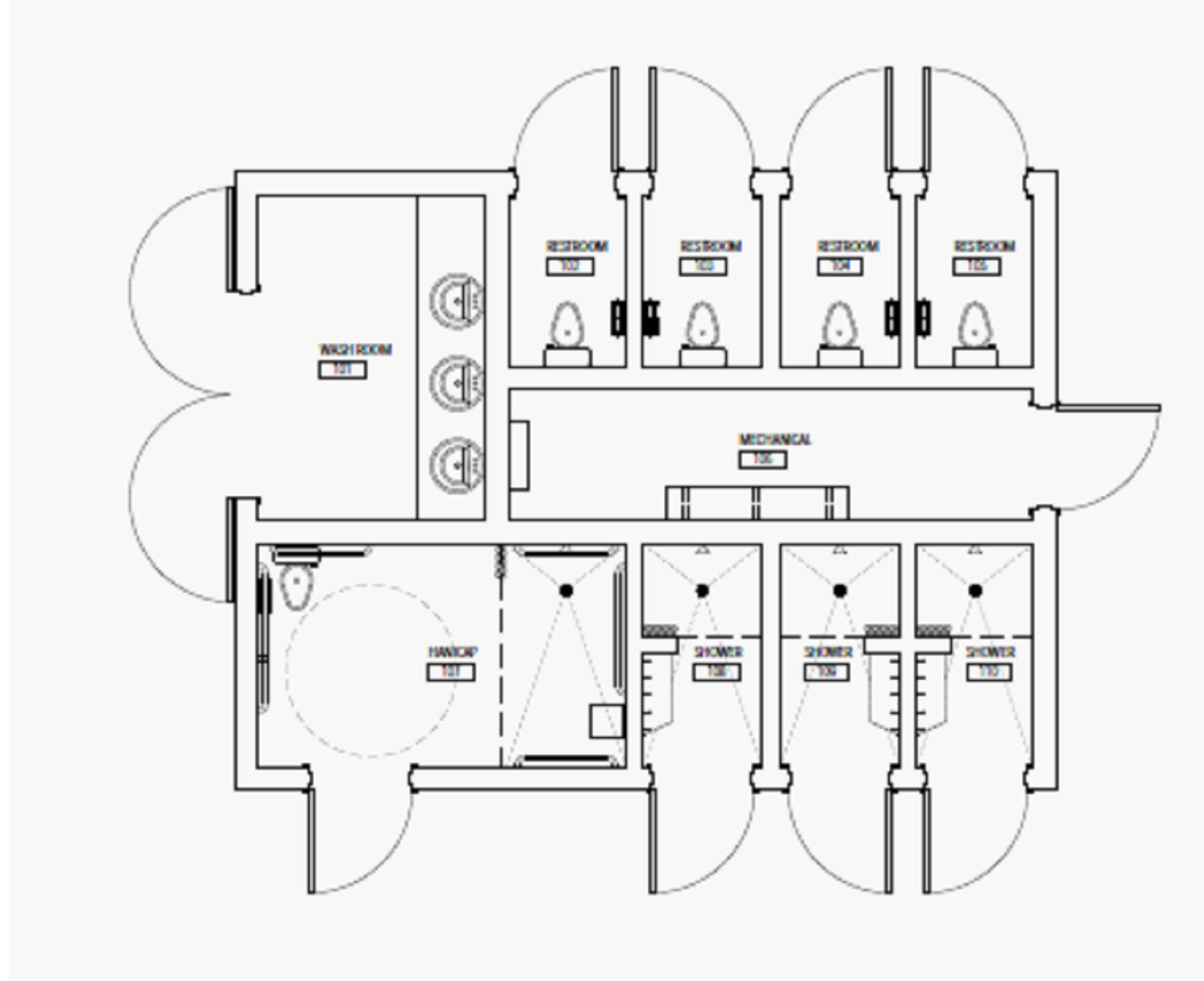

East Bathroom

Accessible Stall (1)	90/space
Non-Accessible Toilet (4)	90/space
Non-Accessible Shower (3)	90/space
Sinks (3)	

West Bathroom

Accessible Stall (1)	90/space
Non-Accessible Toilet (4)	90/space
Non-Accessible Shower (3)	90/space
Sinks (3)	

Trailer Site

Trailers (5)	125/space
--------------	-----------

3 RESTROOM SHOWER BUILDING
NOT TO SCALE

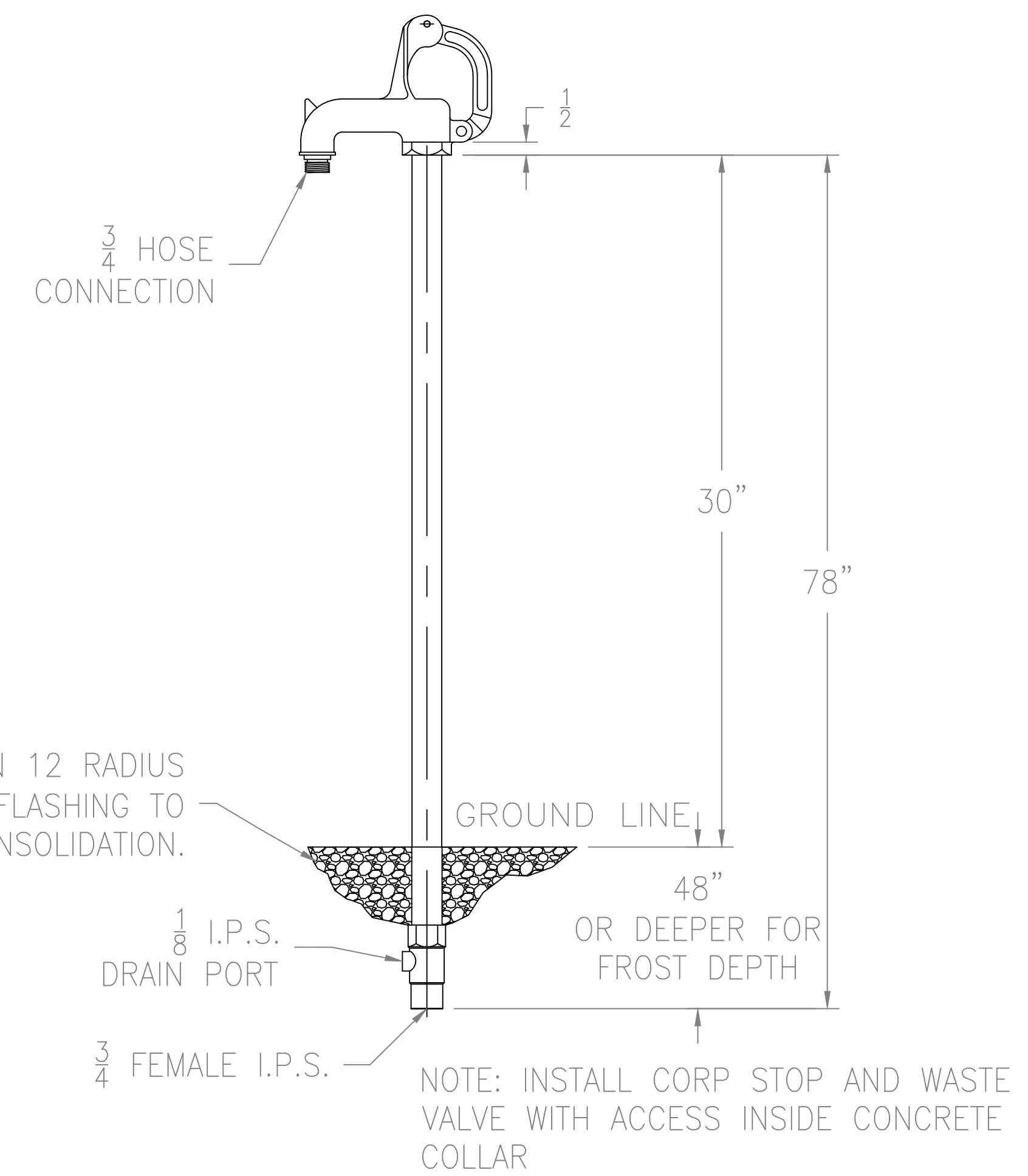

4 TYPICAL YARD HYDRANT
NOT TO SCALE

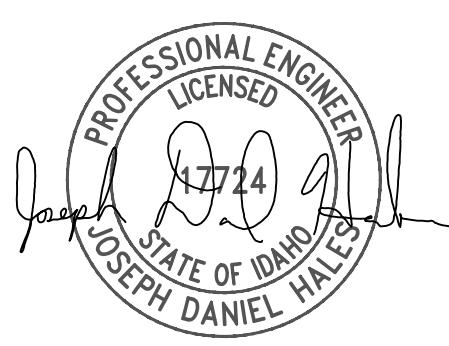

NO.	DATE	DESCRIPTION

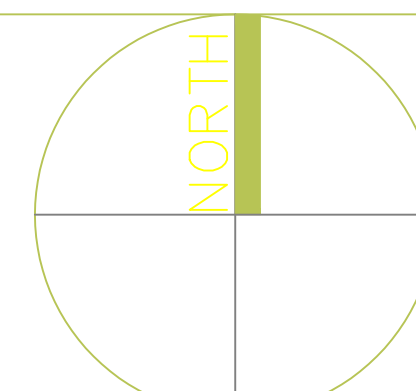

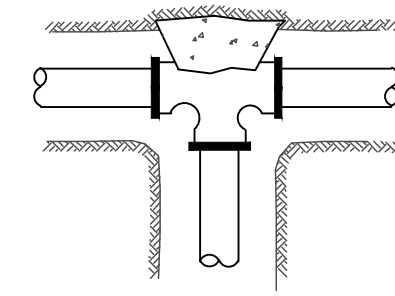

TEE

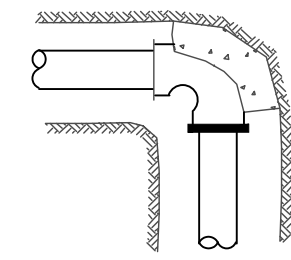

90° ELBOW

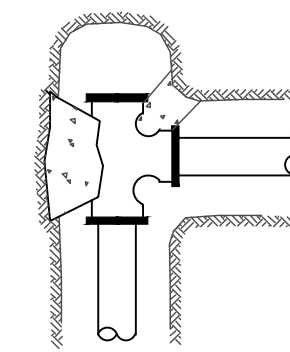

TEE WITH CAP

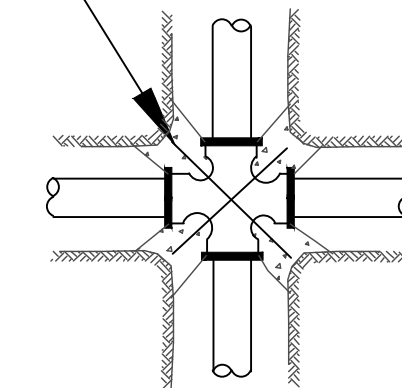

CROSS

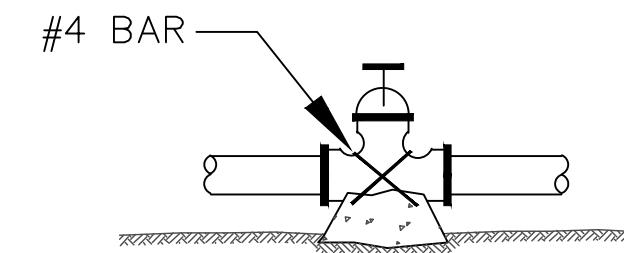

VALVE

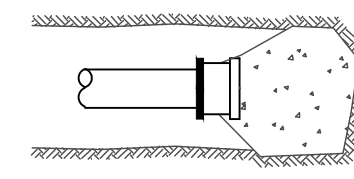

CAP OR PLUG

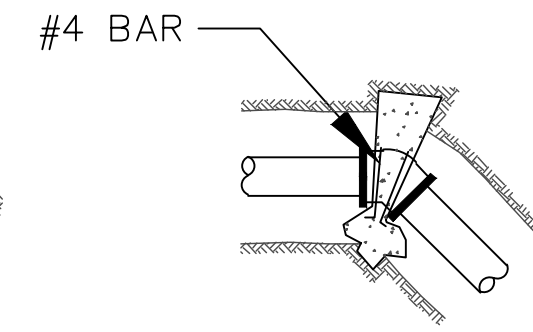

ELBOW

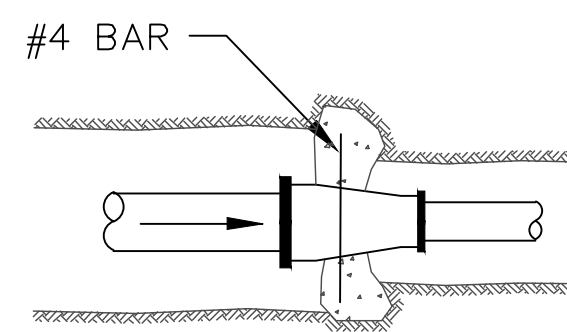

REDUCER

NOTES:

1. REINFORCING BARS REQUIRED FOR HANGING THRUST BLOCKS AND SHALL BE EPOXY COATED.
2. RESIDENT PROJECT ENGINEER WILL CALCULATE QUANTITIES OF CONCRETE REQ'D AND SPECIFY PLACEMENT METHODS & REQUIREMENTS; WHICH SHALL BE APPROVED BY CITY ENGINEER.
3. CONCRETE SHALL BE 4000 PSI MIN.
4. POUR CONCRETE AGAINST UNDISTURBED SOIL.

THRUST ON FITTINGS

POUNDS @ 1 POUND PER SQUARE INCH OF WATER PRESSURE*

PIPE SIZE	TEES/ PLUGS	90° BENDS	45° BENDS	22.5° BENDS
ALL PIPES	18.5	26.1	14.2	7.2

THRUST BLOCK AREA AGAINST TRENCH WALL (SQURE FEET)

ASSUMING SAND AND MAX PRESSURE OF 150 PSI
SIZE MAY BE REDUCED WITH AN ENGINEERED SUBMITTAL
AND AS APPROVED BY THE CITY ENGINEER

PIPE SIZE	TEES/ PLUGS	90° BENDS	45° BENDS	22.5° BENDS
ALL PIPES	2.8	3.9	2.1	1.1

NO.	DATE	DESCRIPTION

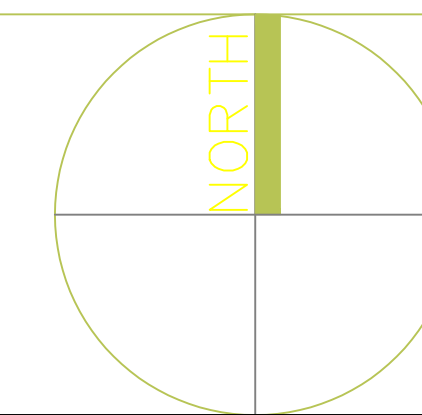

12' BY 51" GALVANIZED STEEL TARTER AMERICAN GATE WITH GALVANIZED 1/2" MINIMUM BOLTED GATE ANCHOR

MINIMUM SEPARATION MATRIX				
	FIRE PIT	TENT	22'X22' DINING SHELTER	PICNIC TABLE
FIRE PIT	N/A	20'	15'	15'
TENT	20'	N/A	10'	15'
22'X22' DINING SHELTER	15'	10'	N/A	10'
PICNIC TABLE	15'	15'	10'	N/A
75.5'X32' PAVILION	25'	15'	N/A	20'
18'X24' BATHROOM	25'	30'	50'	50'

1 GATE DETAIL NOT TO SCALE

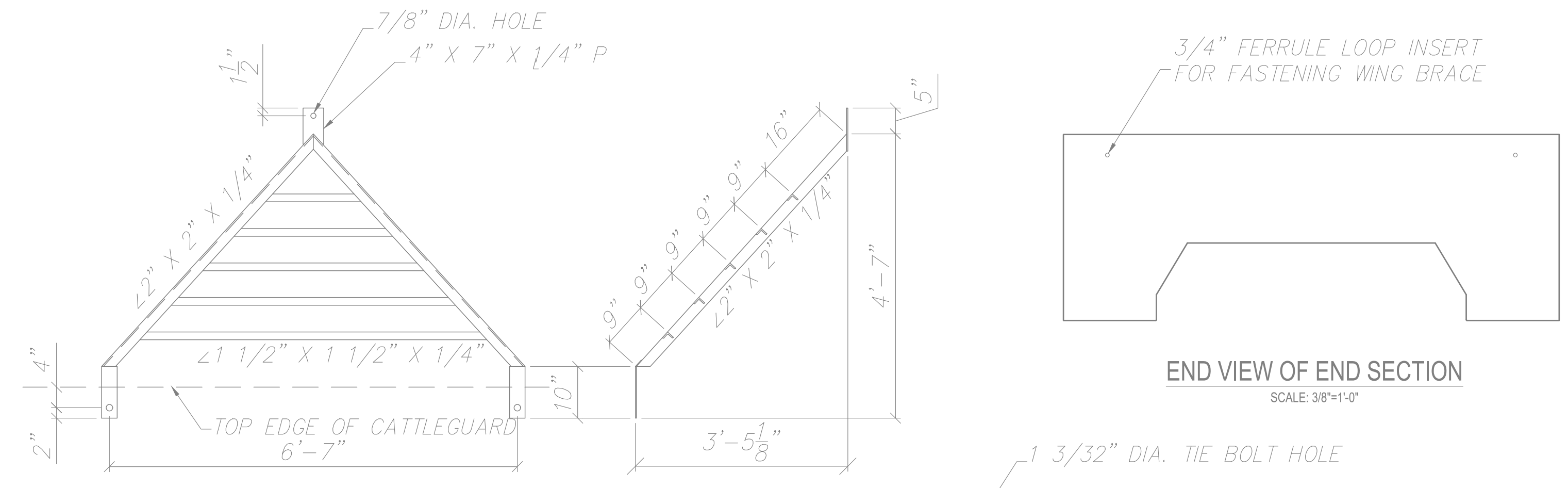

WING BRACE DETAIL SCALE: 3/8"=1'-0"

END VIEW OF END SECTION SCALE: 3/8"=1'-0"

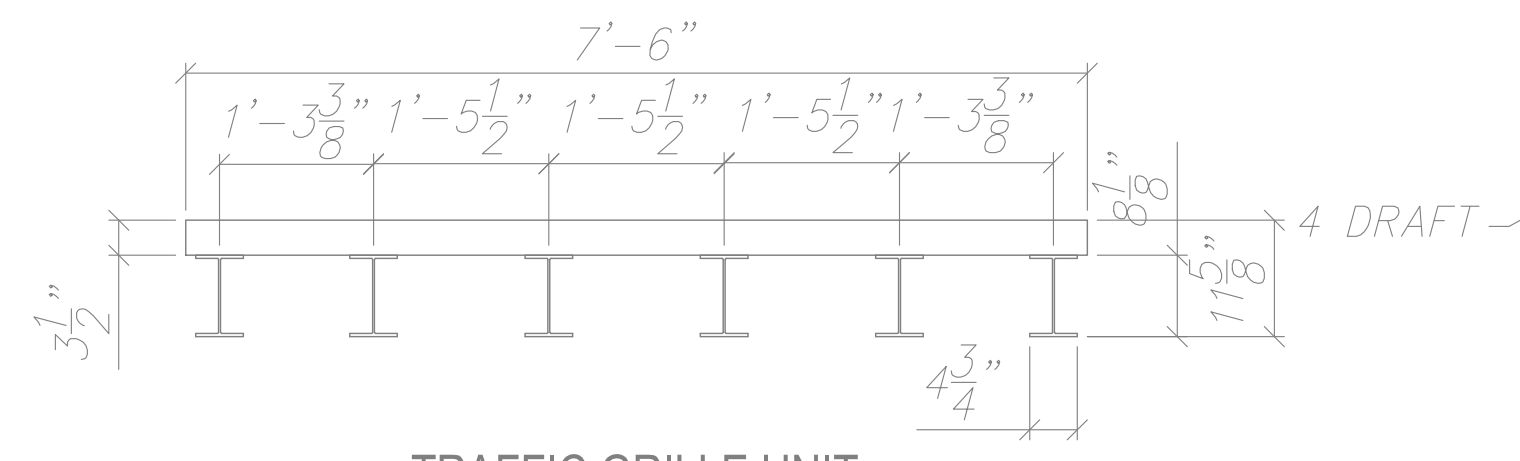

TRAFFIC GRILLE UNIT SCALE: 3/8"=1'-0"

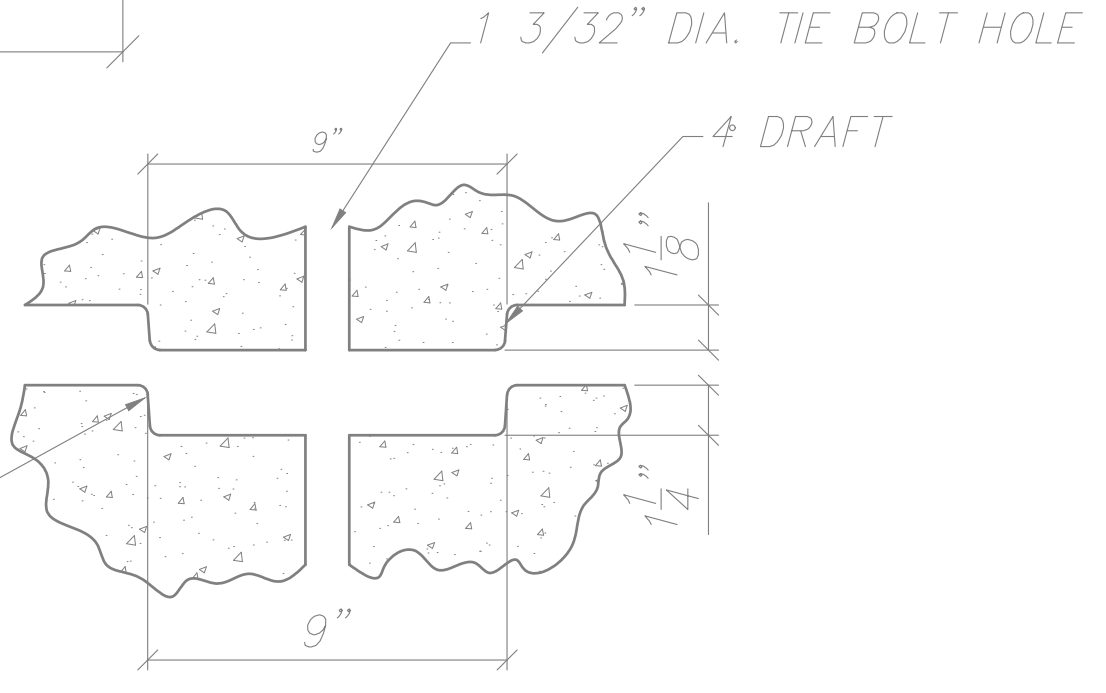

KEY DETAIL SCALE: 3/8"=1'-0"

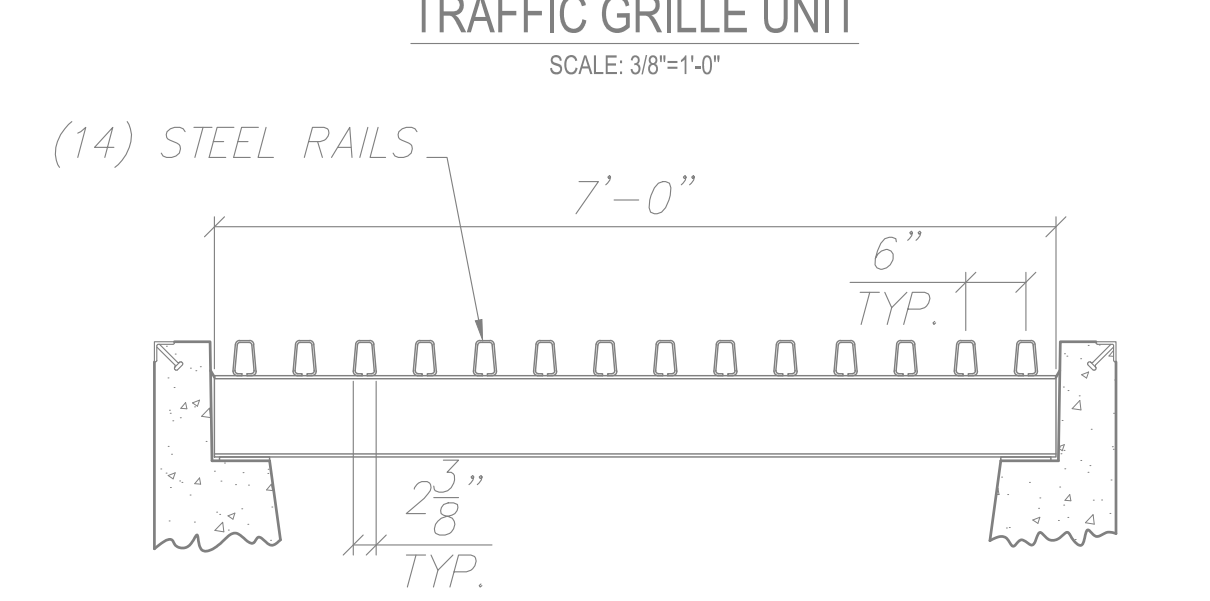

SECTION OF TRAFFIC GRILLE SCALE: 3/8"=1'-0"

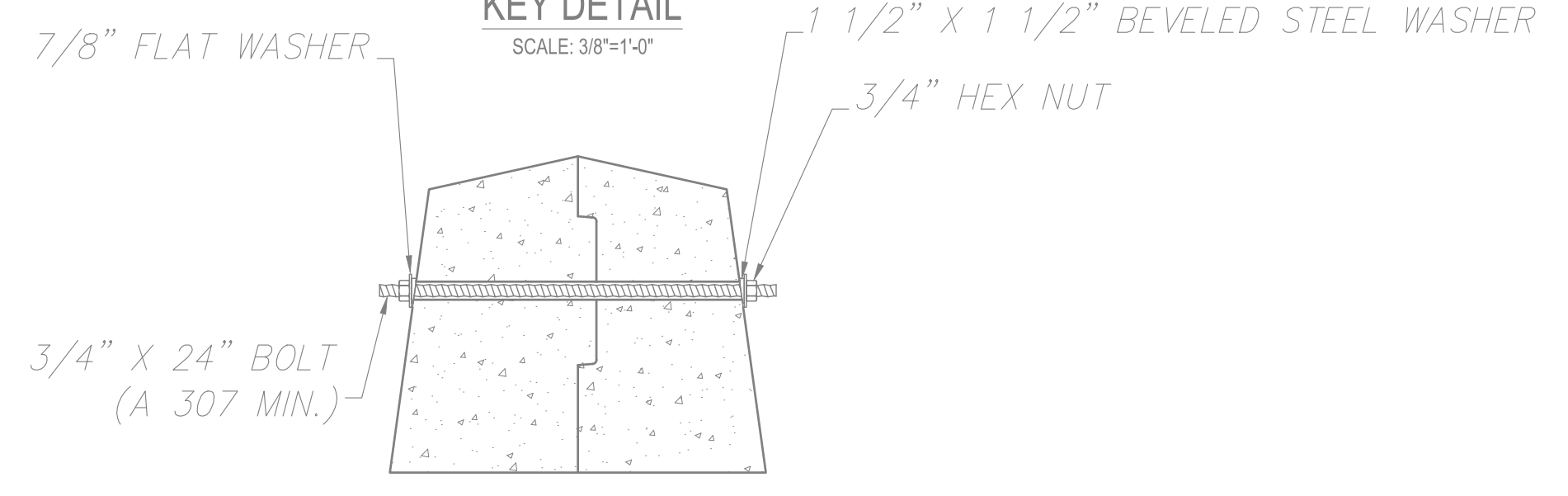

THE BOLT DETAIL SCALE: 3/8"=1'-0"

2 CATTLE GAURD DETAILS NOT TO SCALE

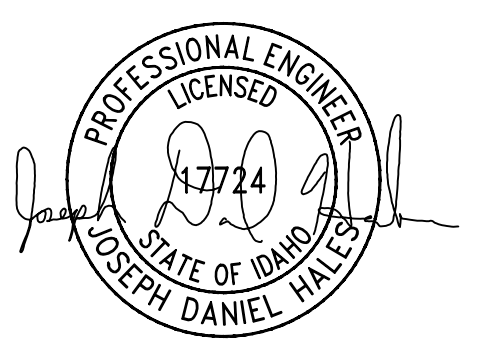

NO.	DATE	DESCRIPTION

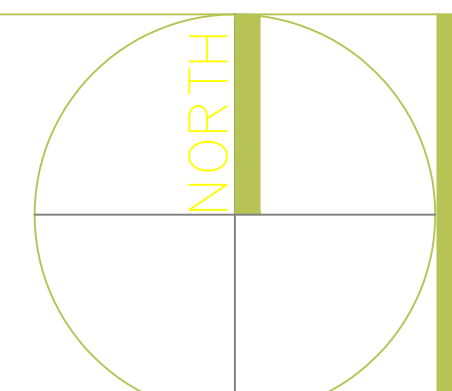

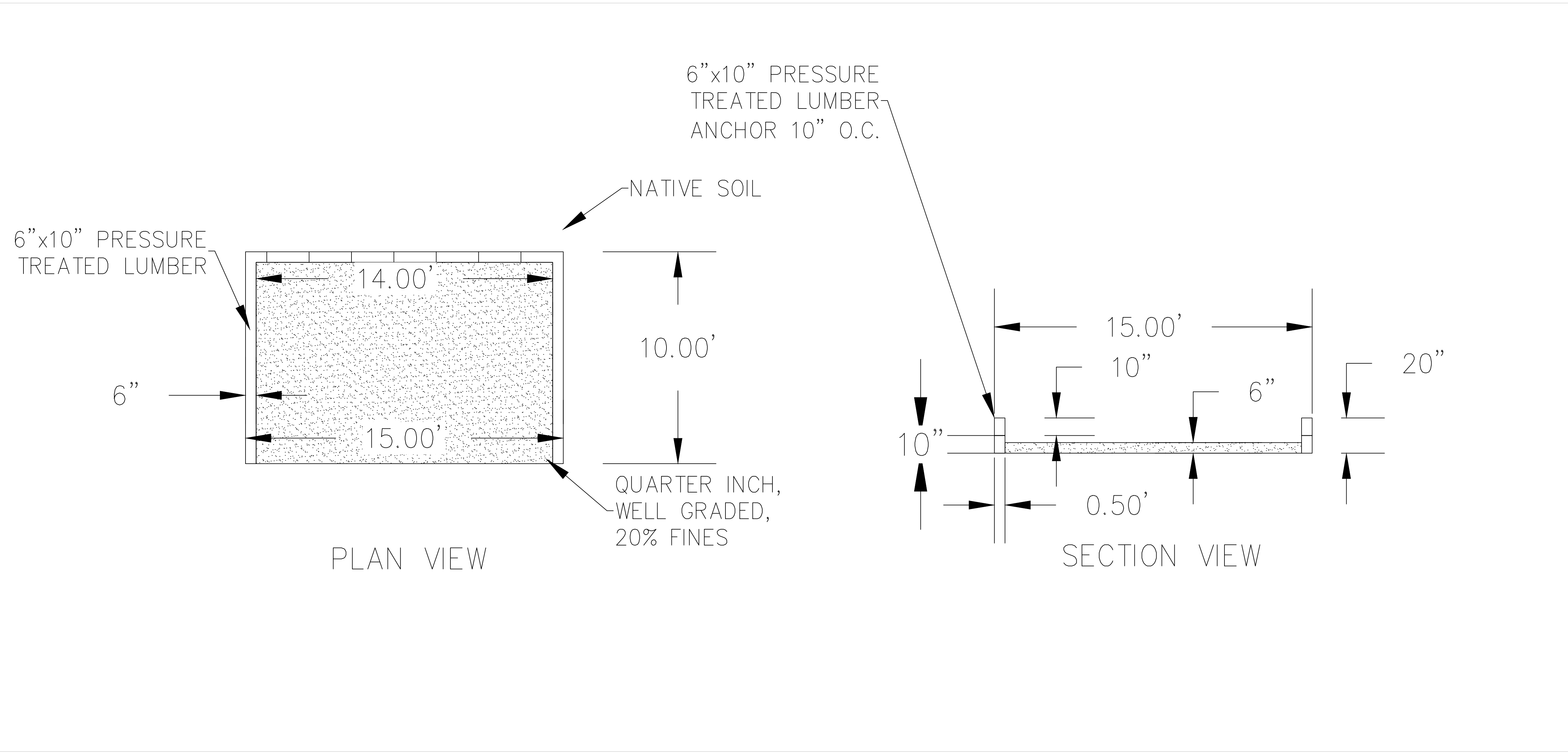

1 TENT PAD DETAILS
NOT TO SCALE

NO.	DATE	DESCRIPTION

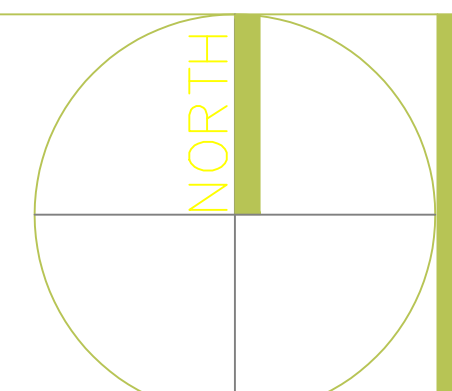

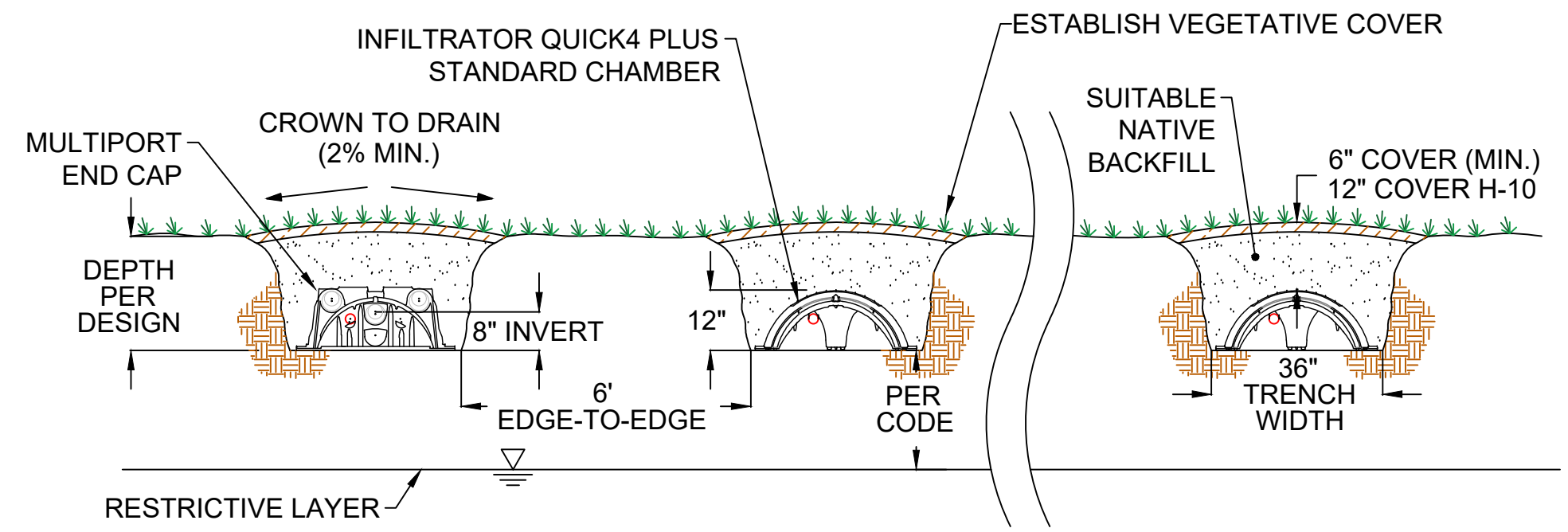

CROSS SECTION

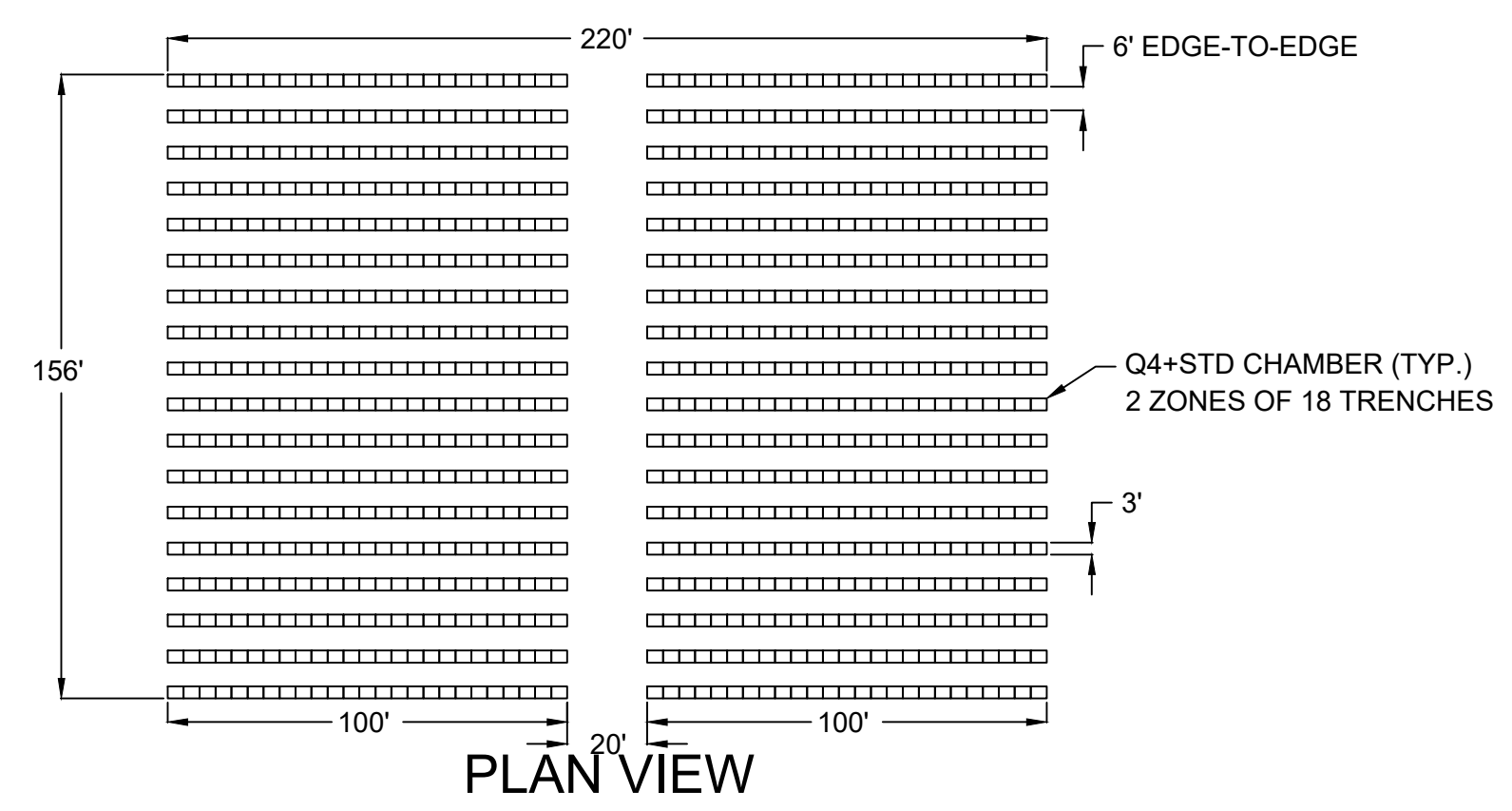

PLAN VIEW

BASIS OF DESIGN:
DAILY DESIGN FLOW = 5,500 GPD
C1 SOIL LOADING RATE = 0.4 GPD/SF
REQUIRED AREA = 13,750 SF (5,500 GPD / 0.4 GPD/SF)
QUICK4 PLUS STANDARD CHAMBER RATING = 16 SF/CHAMBER
REQUIRED CHAMBERS = 860 (13,750 SF / 16 SF/CHAMBER)
PROVIDED CHAMBERS = 900

INFILTRATOR
INFILTRATOR WATER TECHNOLOGIES
4 Business Park Rd. Old Saybrook, CT 06475
(800) 221-4436

HULL CANYON CAMPGROUND
FRANKLIN COUNTY, ID
SITE 1 - CROSS SECTION AND PLAN VIEW

Drawn by: JLK Date: 3/9/2023
Scale: NOT TO SCALE Checked by: JPH Sheet: 1 of 9

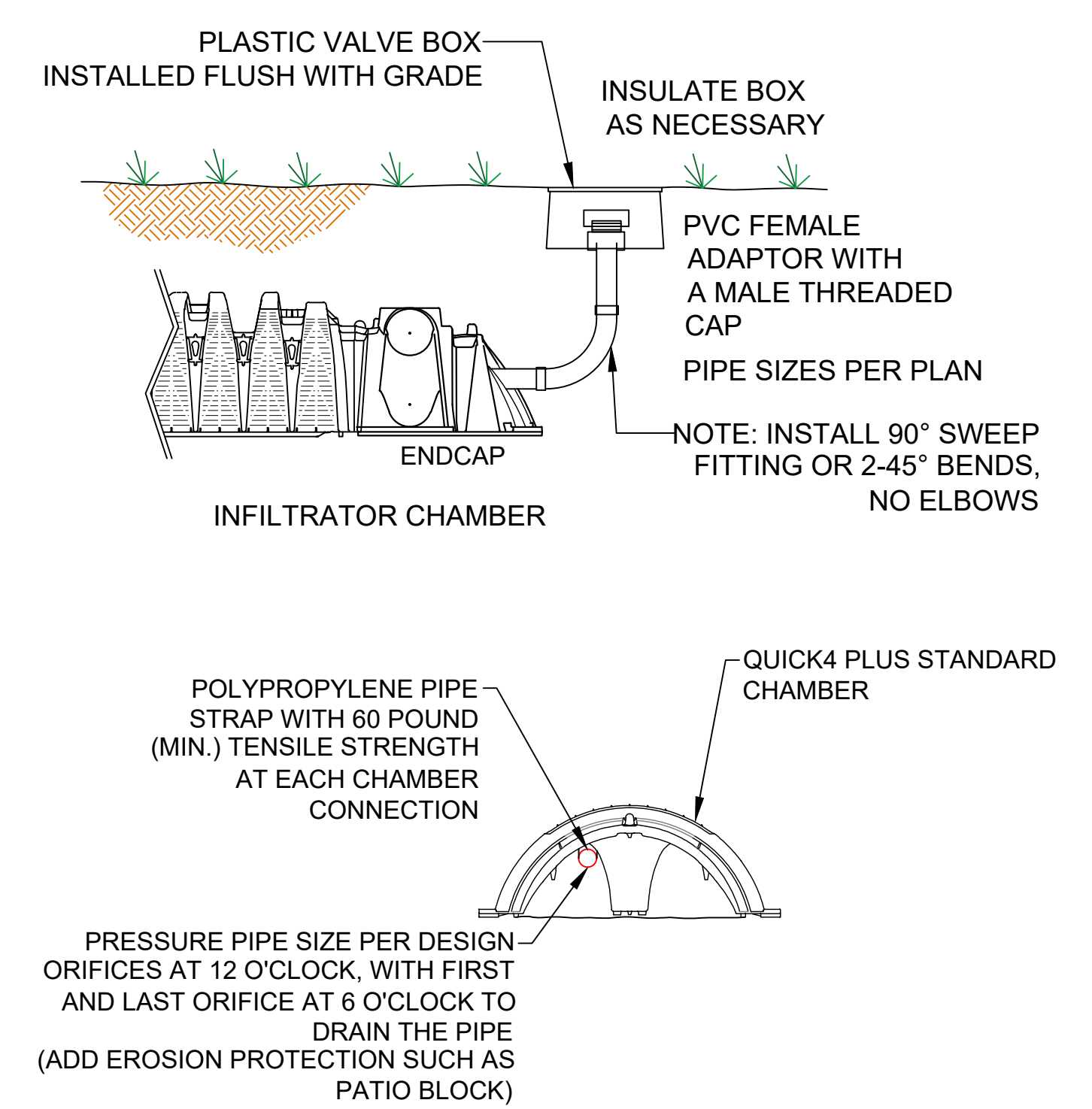
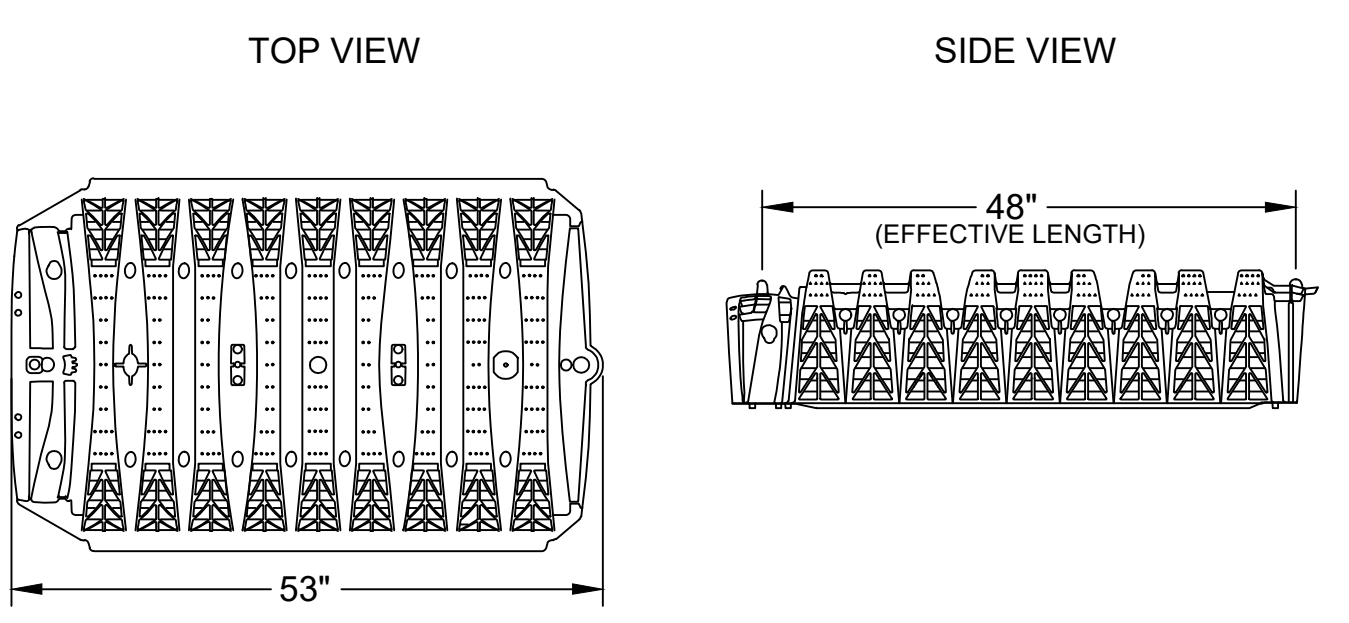

PRESSURE PIPE CONFIGURATION

INFILTRATOR
INFILTRATOR WATER TECHNOLOGIES
4 Business Park Rd. Old Saybrook, CT 06475
(800) 221-4436

HULL CANYON CAMPGROUND
FRANKLIN COUNTY, ID
SITE 1 - PRESSURE PIPE CONFIGURATION

Drawn by: JLK Date: 3/9/2023
Scale: NOT TO SCALE Checked by: JPH Sheet: 2 of 9

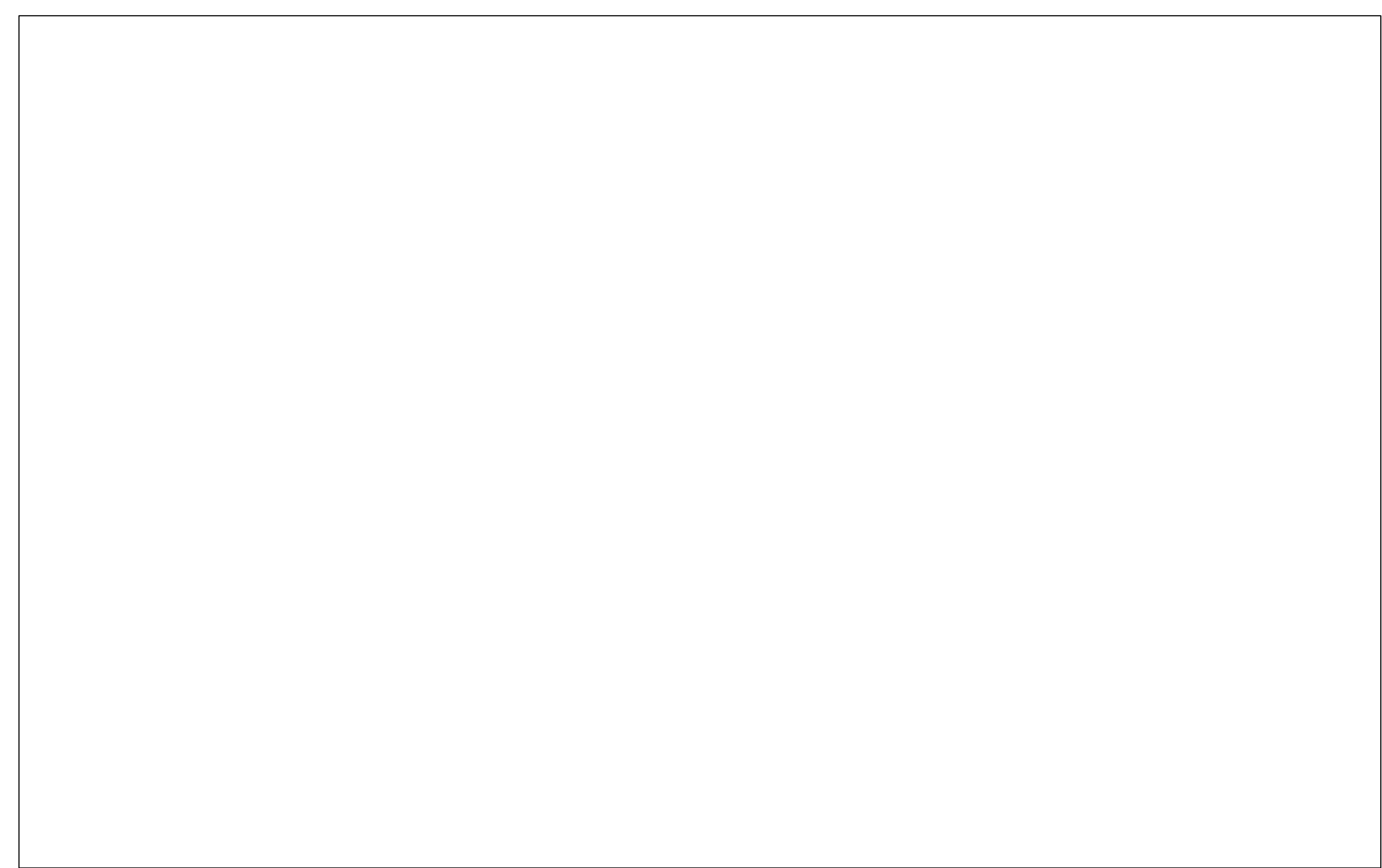

INFILTRATOR
INFILTRATOR WATER TECHNOLOGIES
4 Business Park Rd. Old Saybrook, CT 06475
(800) 221-4436

HULL CANYON CAMPGROUND
FRANKLIN COUNTY, ID
SITE 1 - SITE LAYOUT

Drawn by: JLK Date: 3/9/2023
Scale: NOT TO SCALE Checked by: JPH Sheet: 3 of 9

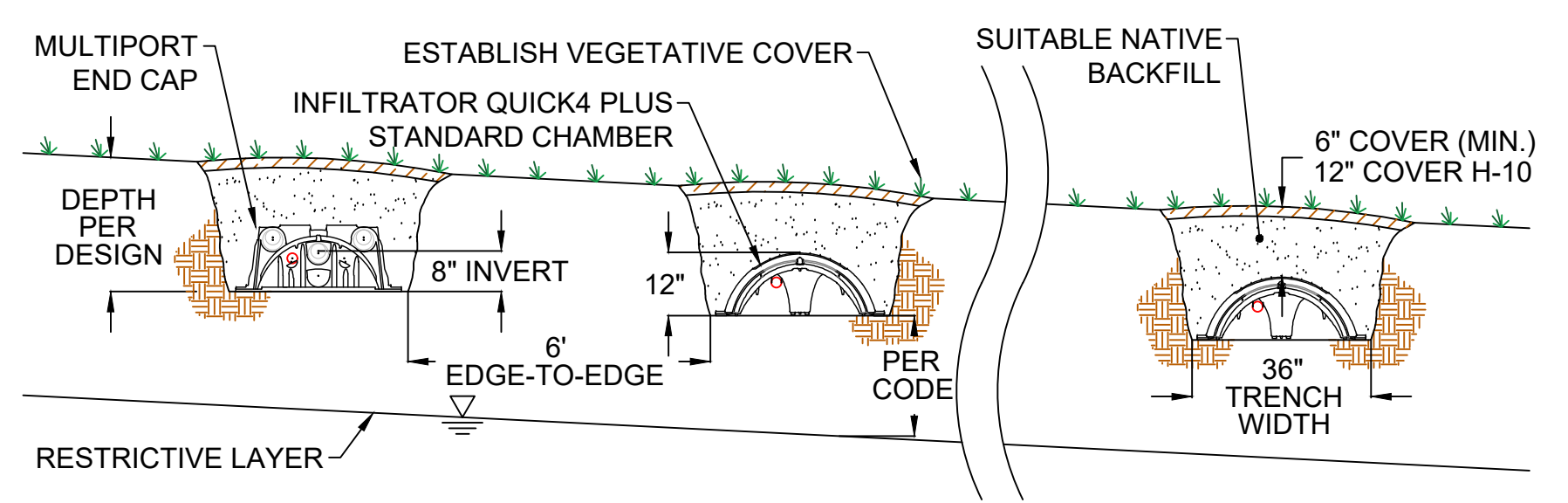

CROSS SECTION

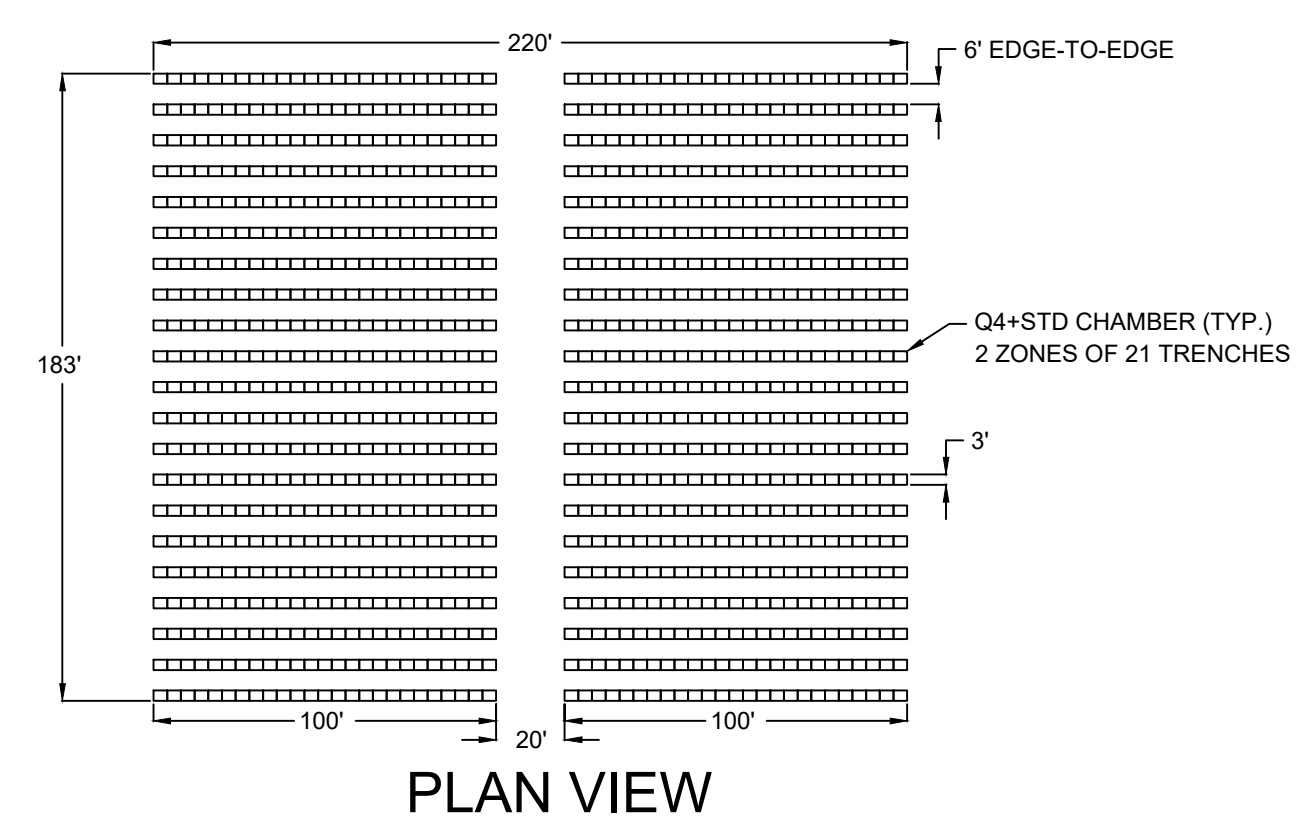

PLAN VIEW

BASIS OF DESIGN:
DAILY DESIGN FLOW = 6,500 GPD
C1 SOIL LOADING RATE = 0.4 GPD/SF
REQUIRED AREA = 16,250 SF (6,500 GPD / 0.4 GPD/SF)
QUICK4 PLUS STANDARD CHAMBER RATING = 16 SF/CHAMBER
REQUIRED CHAMBERS = 1,016 (16,250 SF / 16 SF/CHAMBER)
PROVIDED CHAMBERS = 1,050

INFILTRATOR
INFILTRATOR WATER TECHNOLOGIES
4 Business Park Rd. Old Saybrook, CT 06475
(800) 221-4436

HULL CANYON CAMPGROUND
FRANKLIN COUNTY, ID
SITE 2 - CROSS SECTION AND PLAN VIEW

Drawn by: JLK Date: 3/9/2023
Scale: NOT TO SCALE Checked by: JPH Sheet: 4 of 9

100% FOR BID ONLY, NOT FOR CONSTRUCTION

STUDIO 333 ARCHITECTS
333 24TH STREET
OGDEN, UT 84401
801.394.3033

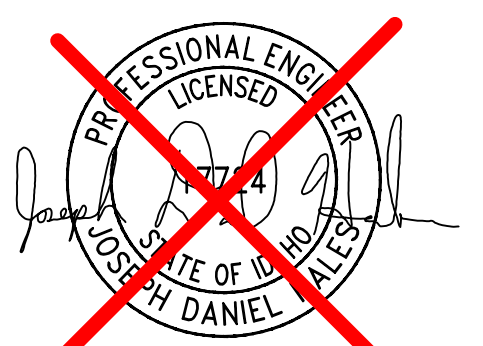

CAMP HULL VALLEY IMPROVEMENTS
10100 EAST CUB RIVER RD, PRESTON, IDAHO



NO.	DATE	DESCRIPTION

DATE: 03.15.23
PROJECT NUMBER: 06522
PROPERTY NUMBER: 501-737121050101

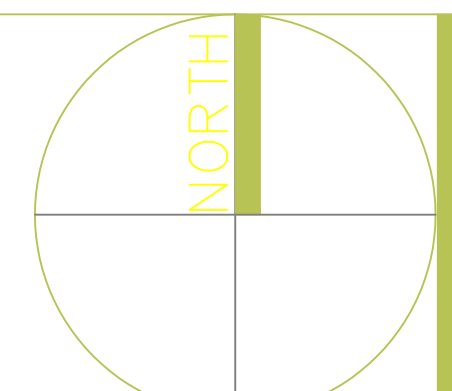

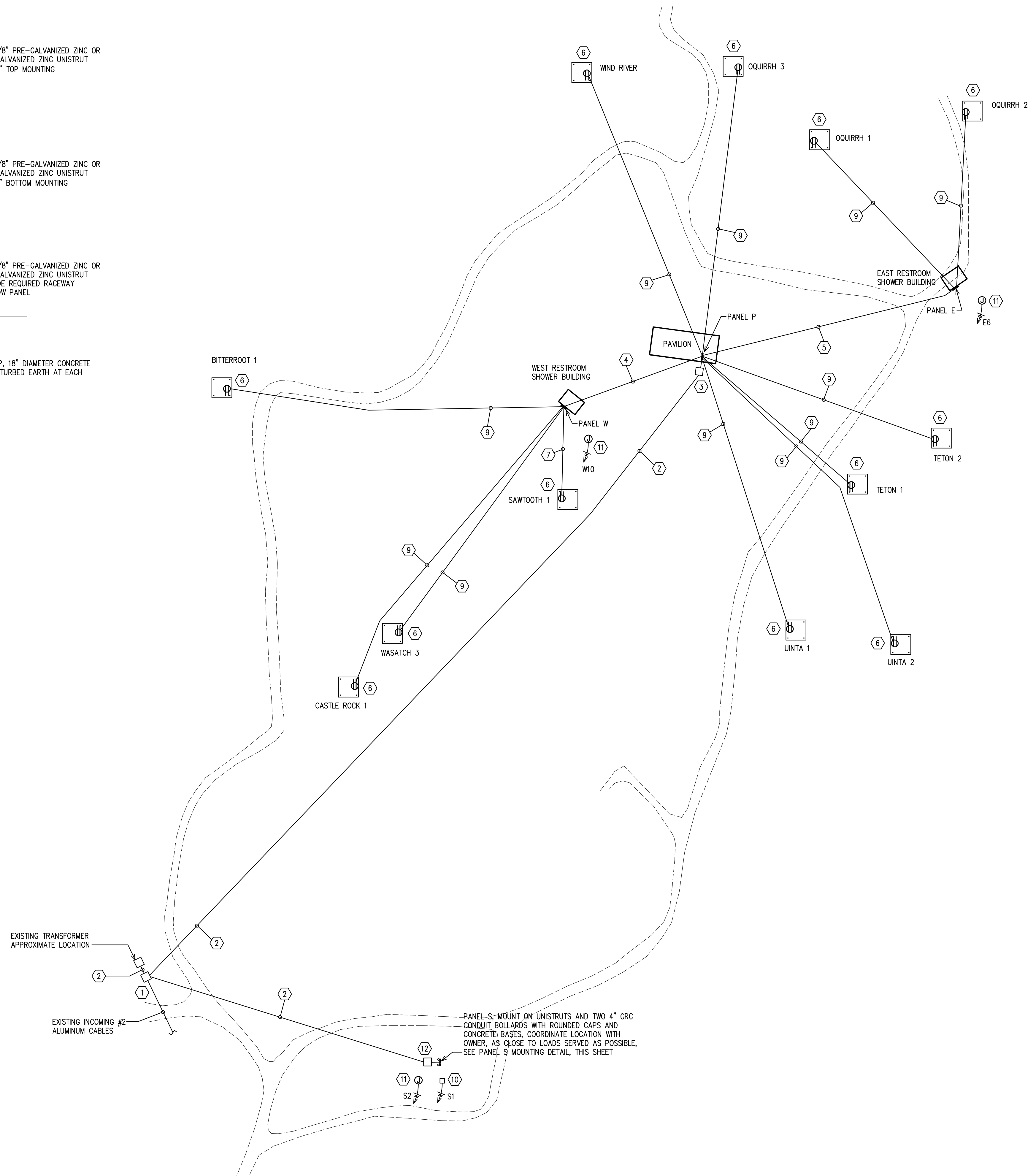
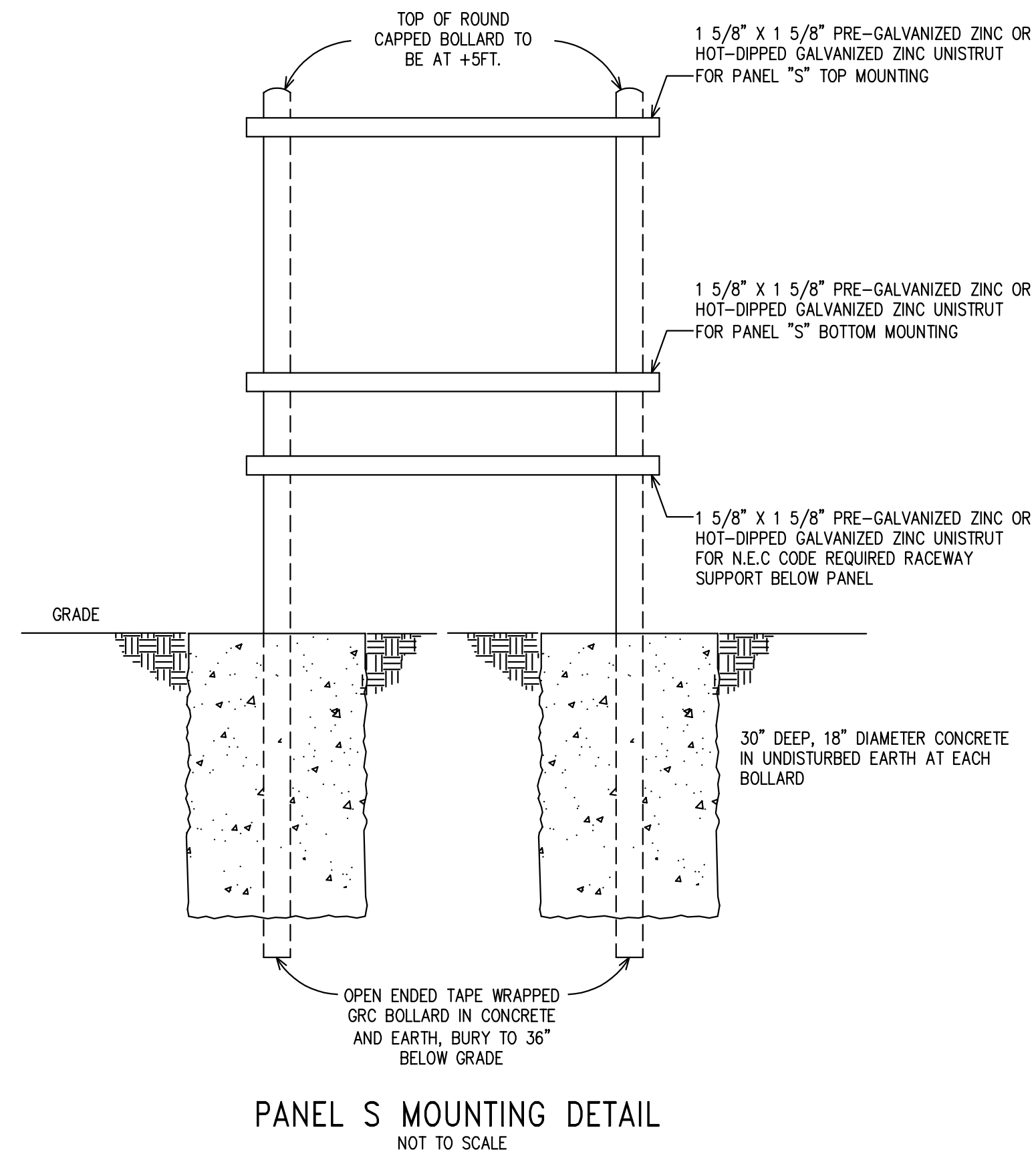

- KEYED NOTES: (#)
1. SINGLE PHASE SECTIONALIZER/GROUND SLEEVE WITH ELBOWS AND LOAD CENTERS ETC AS REQUIRED FOR A COMPLETE SYSTEM TO CONNECT EXISTING 12470V PRIMARY, EXISTING 25KVA 120/240V TRANSFORMER AND NEW 75KVA 120/240V AND 50KVA 120/240V TRANSFORMERS. 4 POSITION MINIMUM. SEE NOTE 2 BELOW FOR CABLE SIZING.
 2. #2 ALUMINUM CABLES 12470V RATED. DIRECT BURIAL CABLE WITH WARNING TAPE INSTALLED. PULL BOXES AS REQUIRED.
 3. 75 KVA 120/240V TRANSFORMER, SEE NORTH ONE LINE DIAGRAM.
 4. 3#250MCM CU WIRE PLUS #1 CU GROUND IN 3" CONDUIT. OVERSIZED GROUND PER NEC 250.122B.
 5. 3#350MCM CU WIRE PLUS #2/0 CU GROUND IN 3" CONDUIT. OVERSIZED GROUND PER NEC 250.122B.
 6. STUB CONDUIT UP INSIDE COLUMN. INSTALL GFI OUTLET IN WEATHERPROOF CAST METAL IN--USE COVER.
 7. 2#10 CU WIRE PLUS #10 CU GROUND IN 3/4" CONDUIT. PULL BOXES AS REQUIRED.
 8. 2#8 CU WIRE PLUS #8 CU GROUND IN 1" CONDUIT. PULL BOXES AS REQUIRED.
 9. 2#6 CU WIRE PLUS #6 CU GROUND IN 1 1/4" CONDUIT. PULL BOXES AS REQUIRED.
 10. MIDWEST RV PEDESTAL #U075CP6010 METAL EARTH BURIAL PEDESTAL. CONDUIT TO BE PVC WITH TAPE WRAPPED GRC ELBOWS. PROVIDE #10 GROUND TO GROUND ROD AT PEDESTAL.
 11. SEWAGE PUMP, 240V 1Ø 4A. PROVIDE DIRECT CONNECT OR OUTLET AS REQUIRED BY VENDOR SHOP DRAWINGS AND CIVIL DRAWINGS.
 12. 50 KVA 120/240V TRANSFORMER, SEE SOUTH ONE LINE DIAGRAM

STUDIO 333 ARCHITECTS
333 24TH STREET
OGDEN, UT 84401
801.394.3033

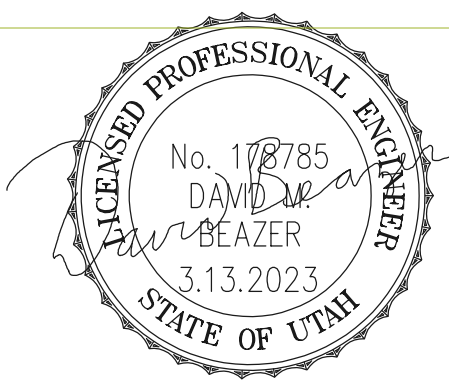

CAMP HULL VALLEY IMPROVEMENTS
10100 EAST CUB RIVER RD.
PRESTON, IDAHO

BE BEAZER ENGINEERING INC.
P.O. BOX 652
MILLVILLE, UTAH 84326
C 435.770.8999
david@beazer-engineering.com

NO.	DATE	DESCRIPTION

DATE: 03.15.23
PROJECT NUMBER: 2223
PROPERTY NUMBER: 501-737121050101

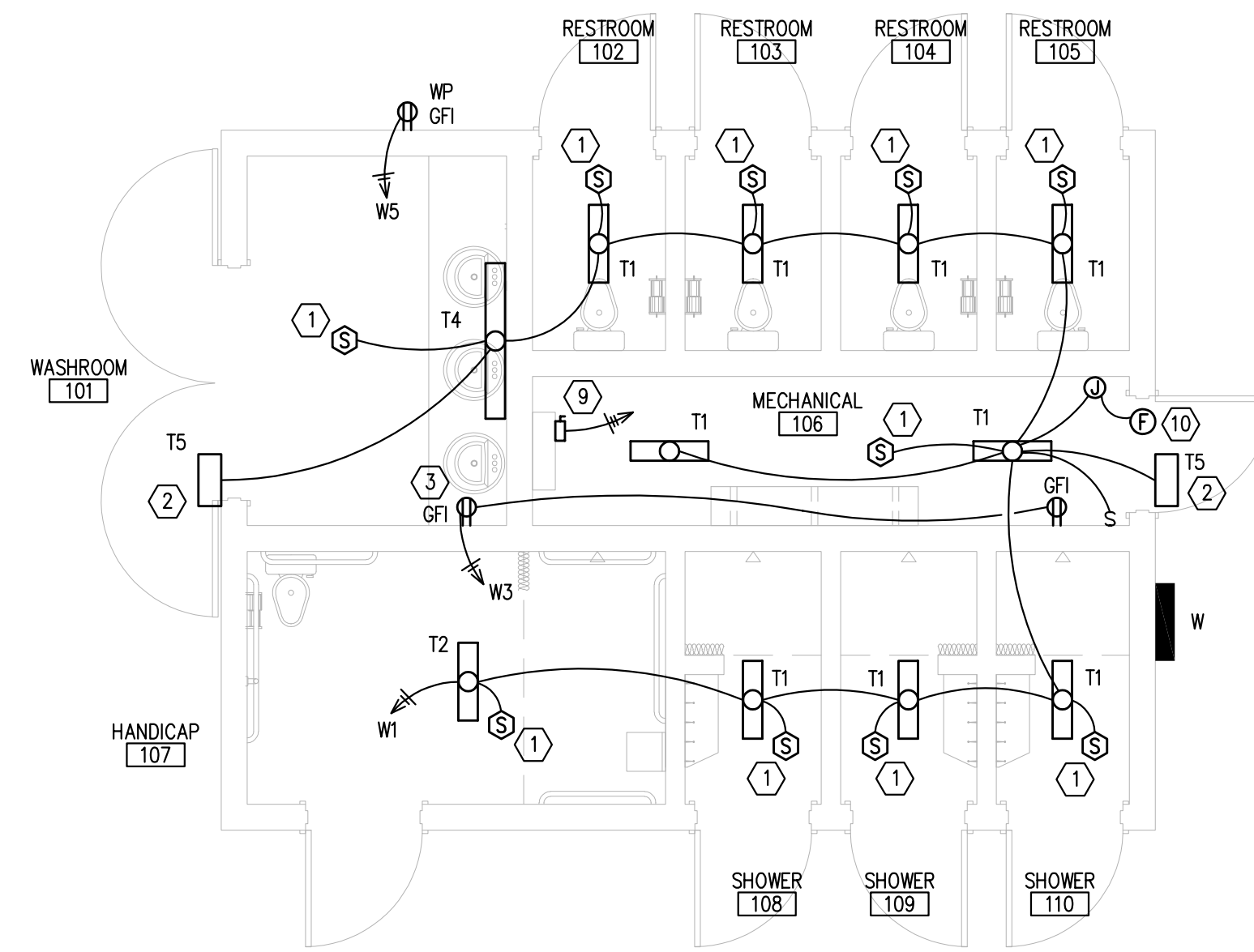

WEST RESTROOM
SHOWER BUILDING

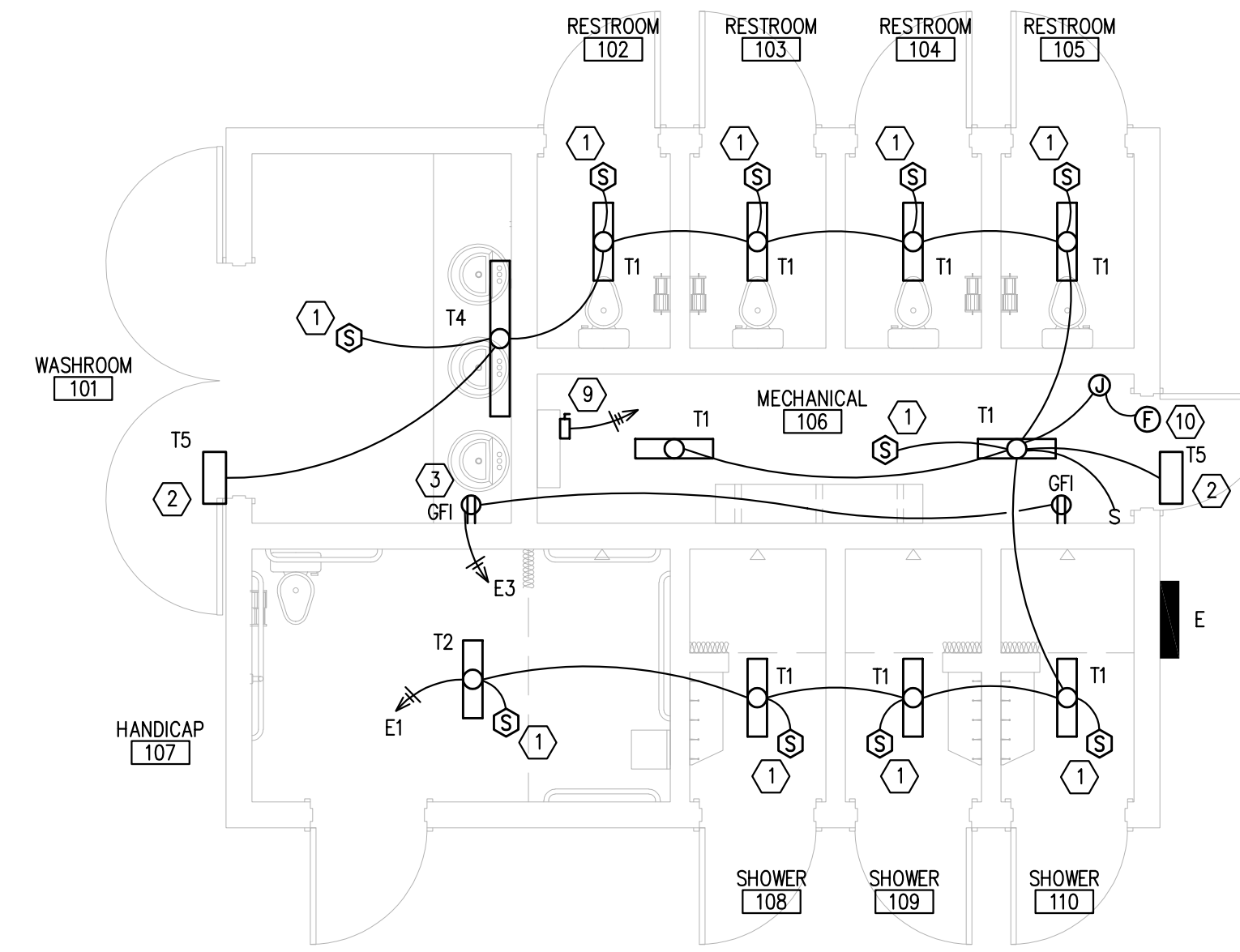

EAST RESTROOM
SHOWER BUILDING

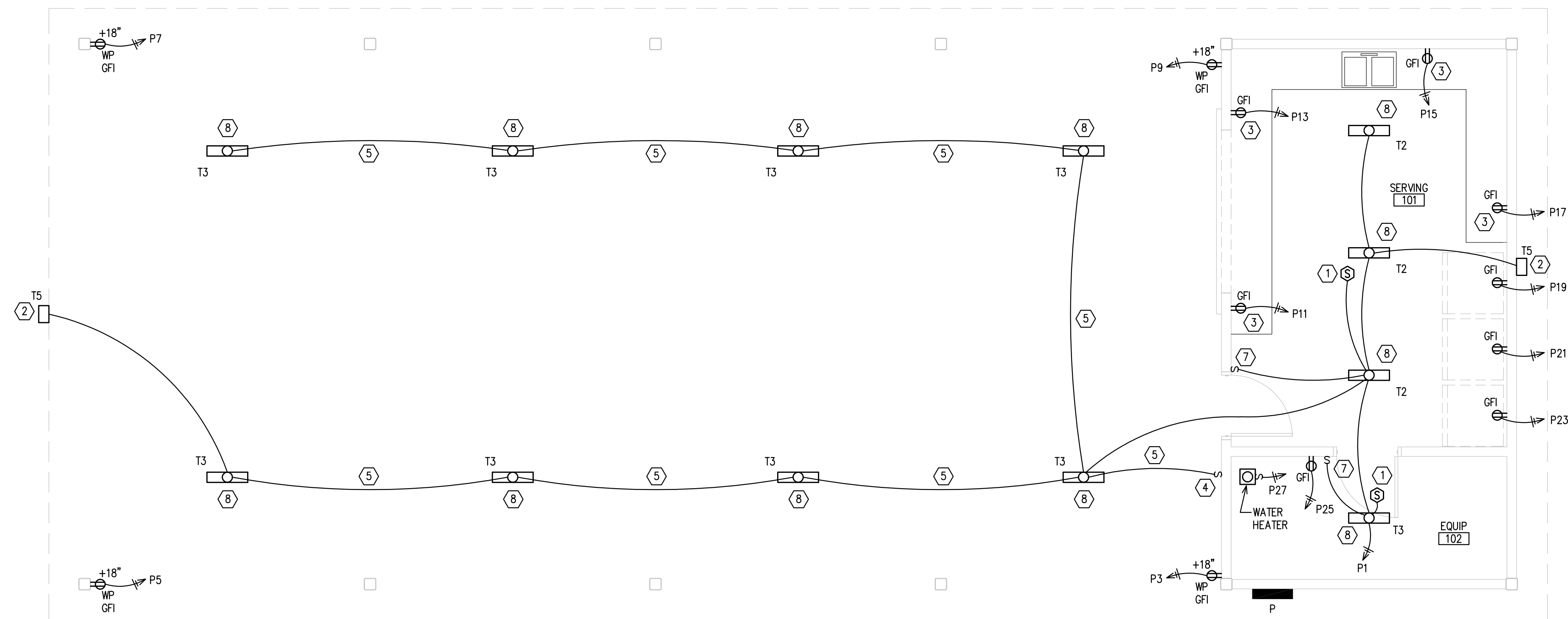

PAVILION

GENERAL NOTES:

- A. OUTLETS TO BE GFCI WHERE REQUIRED BY NEC. WHEN LABELLED OR NOT.

KEYED NOTES: (#)

1. CEILING MOUNT OCCUPANCY SENSOR. AUTO ON, AUTO OFF. WATTSTOPPER DT300 SENSOR(S) WITH BZ-150 POWER PACK(S) SET TO OCCUPANCY SETTING. SENSOR(S) TO CONTROL ALL LIGHTS IN ROOM UNLESS SHOWN OTHERWISE. INSTALL PER MANUFACTURER WIRING DIAGRAMS. PROVIDE BZ-150 POWER PACK AT EACH SEPARATELY SWITCHED LOCATION.
2. OUTDOOR WALLPACK TO HAVE INTEGRAL PHOTOCELL CONTROL.
3. LOCATE OUTLET(S) ABOVE COUNTER, SEE ARCHITECTURAL.
4. INSTALL TIME SWITCH (4-HOUR CYCLE, NO-HOLD, AUTOMATIC SHUT-OFF, INTERMATIC #F34H OR EQUAL BY PARAGON OR TORK) WITH WEATHERPROOF COVER 48 INCHES ABOVE CONCRETE SLAB TO TOP OF BOX. USE INTERMEDIATE METAL CONDUIT OR RIGID STEEL CONDUIT WHERE EXPOSED.
5. CONNECT LIGHT FIXTURES WITH SURFACE MOUNT 1/2-INCH EMT AND STEEL FITTINGS AND NO. 12 THWN OR XHHW COPPER CONDUCTORS. CONDUIT NOT TO BE ATTACHED TO ROOF DECKING. ATTACH TO BEAMS OR PURLINS.
6. PROVIDE SUPPLEMENTARY GROUNDING AT PANEL AS SHOWN.
7. INSTALL TIME SWITCH (4-HOUR CYCLE, NO-HOLD, AUTOMATIC SHUT-OFF, INTERMATIC #F34H OR EQUAL BY PARAGON OR TORK) WITH WEATHERPROOF COVER 48 INCHES ABOVE CONCRETE SLAB TO TOP OF BOX.
8. MOUNT LIGHTS ON PURLINS. LIGHT FIXTURES NOT TO BE MOUNTED ON ROOF DECKING.
9. WATER HEATER, RUN #1 CU WIRE PLUS #8 CU GROUND IN 3/4" CONDUIT TO 125A 2P BREAKER IN PANEL.
10. WALL EXHAUST FAN. CIRCUIT THROUGH J-BOX FOR PROGRAMMABLE TIMER SWITCH CONTROL PROVIDED BY MECHANICAL.

LIGHT FIXTURE SCHEDULE

TYPE	MANUFACTURER/CATALOG NO.	MOUNTING	LAMPS
T1	LITHONIA DMW2 L24 2000LM PCL MD MVOLT 30K 80CRI	SURFACE	LED (19W)
T2	LITHONIA DMW2 L24 3000LM PCL MD MVOLT 30K 80CRI	SURFACE	LED (28W)
T3	LITHONIA DMW2 L24 4000LM PCL MD MVOLT 30K 80CRI	SURFACE	LED (40W)
T4	LUMINAIRE LED SUPERNOVA LVP751 AL NODIM 25W 30K 120 CLP WHIT	WALL ABOVE MIRROR	LED (25W)
T5	LITHONIA WST LED P1 30K VF 120 PE CBA	WALL, HEIGHT PER ARCHITECT	LED (11W)

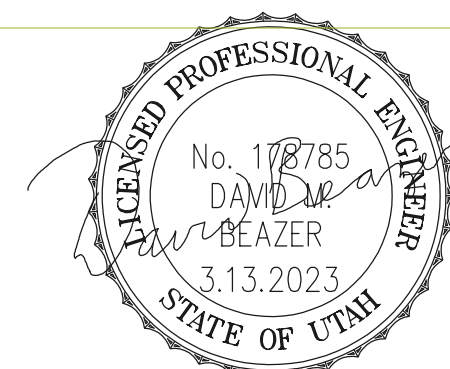

NO.	DATE	DESCRIPTION

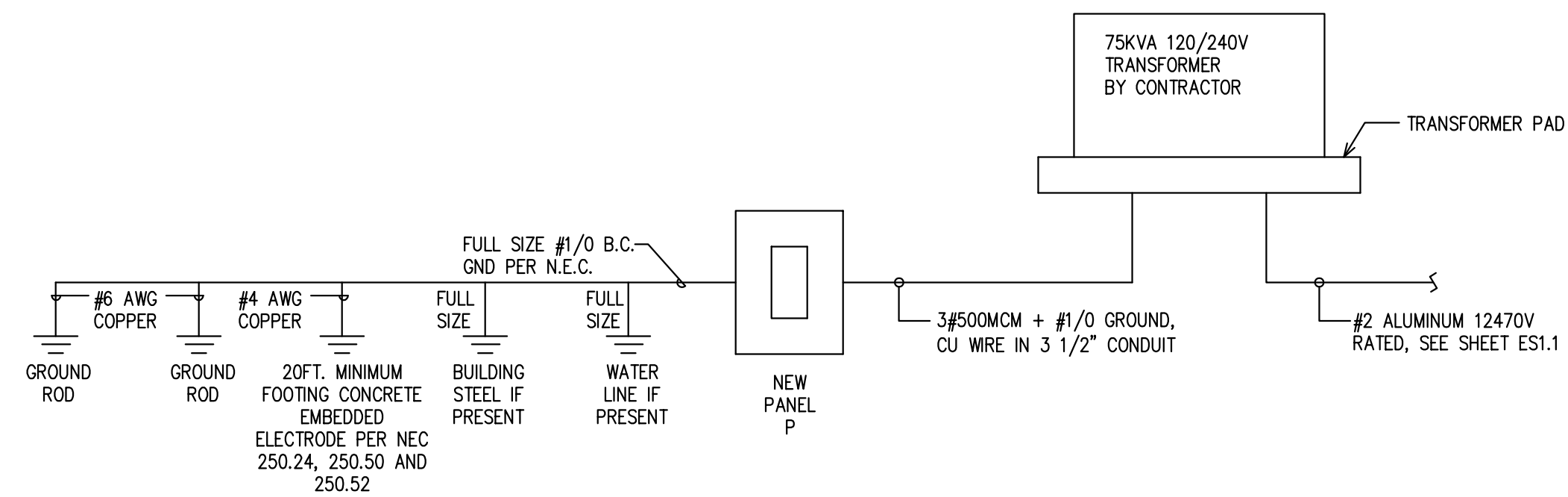

NORTH ONE LINE DIAGRAM

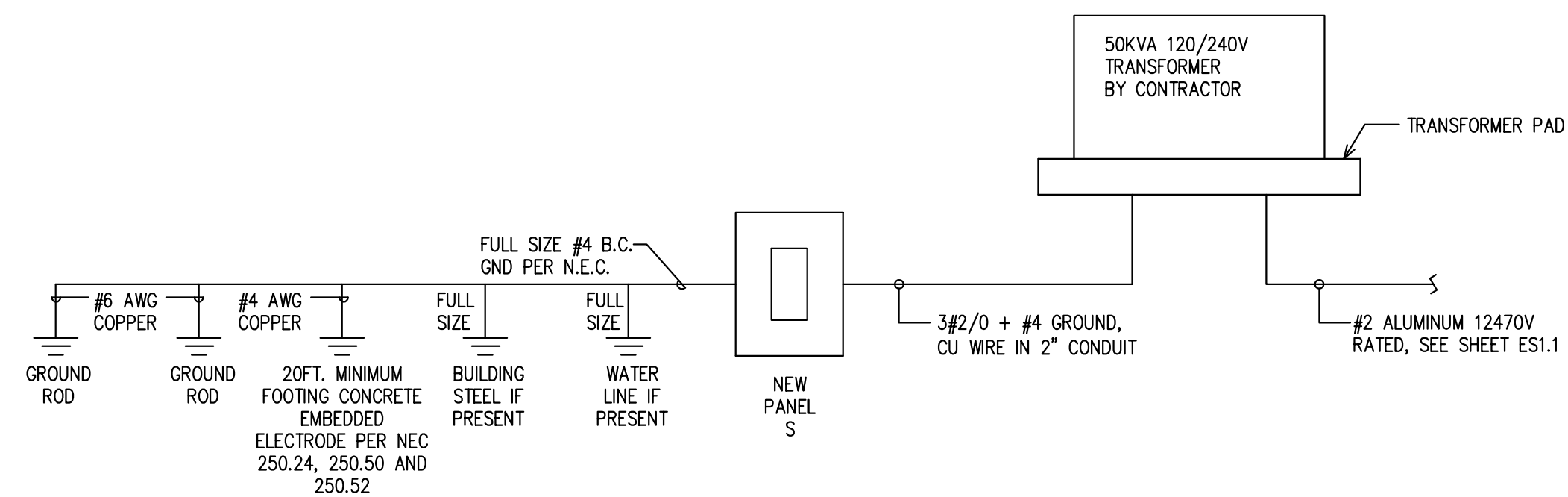

SOUTH ONE LINE DIAGRAM

PANEL P	<input checked="" type="checkbox"/> NEW	TYPE	NOOD	1	Ø	3	WIRE	120/240	VOLTS	LOCATION	MOUNTING								
										PAVILION	<input type="checkbox"/> flush <input checked="" type="checkbox"/> surface								
											400 amp. main								
											<input type="checkbox"/> lugs <input checked="" type="checkbox"/> breaker								
										REMARKS 175A 2P FEED THROUGH BREAKER TO PANEL E 175A 2P FEED THROUGH BREAKER TO PANEL W									
										PANEL E: 14736 14780 PANEL W: 16836 16700									
No.	BRKR	A	P	CIRCUIT DESCRIPTION	L	O	M	Wire	CIRC. LOAD	PHASE	CIRC. LOAD	Wire	L	O	M	CIRCUIT DESCRIPTION	BRKR	No.	
1	20	1		LIGHTS	14			12	595	2515	1920	6	1			WIND RIVER OUTLET	20	1	2
3				OUTSIDE OUTLET					500		2420	1920	6	1		OOUIRRR 3 OUTLET			4
5									500		2420	1920	6	1		TETON 2			6
7									500		2420	1920	6	1		TETON 1			8
9									500		2420	1920	6	1		UINTA 2			10
11									500		2420	1920	6	1		UINTA 1			12
13									500	500						SPARE			14
15									500	500						SPARE			16
17									500	500						SPARE			18
19									500	500						SPACE			20
21									500	500									22
23									500	500									24
25									500	500									26
27									1500	1500						WATER HEATER			28
29																SPARE			30
										TOTALS 40927 41740		AIC 22000							
										3#500MCM + #1/0 GROUND, FEEDER CU WIRE IN 3 1/2" CONDUIT		AMPS/PHASE 341 348		parallel runs 1					

PANEL E	<input checked="" type="checkbox"/> NEW	TYPE	NOOD	1	Ø	3	WIRE	120/240	VOLTS	LOCATION	MOUNTING								
										PAVILION	<input type="checkbox"/> flush <input checked="" type="checkbox"/> surface								
											175 amp. main								
											<input type="checkbox"/> lugs <input checked="" type="checkbox"/> breaker								
										REMARKS 125A 2P FEED THROUGH BREAKER FOR 24KW 240V SINGLE PHASE WATER HEATER									
										PANEL W: 16836 16700									
No.	BRKR	A	P	CIRCUIT DESCRIPTION	L	O	M	Wire	CIRC. LOAD	PHASE	CIRC. LOAD	Wire	L	O	M	CIRCUIT DESCRIPTION	BRKR	No.	
1	20	1		RR LIGHTS	13			12	676	2596	1920	8	1			OOUIRRR 1 OUTLET	20	1	2
3	20	1		RR OUTLETS	2			12	360		2280	1920	8	1		OOUIRRR 2 OUTLET	20	1	4
5	20	1		SPARE					500			1920	10	1		SEWAGE PUMP	20	2	6
7				SPACE					500	500		1920	10	1					8
9																SPACE			10
11																			12
13																			14
15																			16
17											12000								18
										TOTALS 14736 14780		AIC 10000							
										3#350MCM + #2/0 GROUND, FEEDER CU WIRE IN 3" CONDUIT		AMPS/PHASE 123 123		parallel runs 1					

PANEL W	<input checked="" type="checkbox"/> NEW	TYPE	NOOD	1	Ø	3	WIRE	120/240	VOLTS	LOCATION	MOUNTING								
										PAVILION	<input type="checkbox"/> flush <input checked="" type="checkbox"/> surface								
											175 amp. main								
											<input type="checkbox"/> lugs <input checked="" type="checkbox"/> breaker								
										REMARKS 125A 2P FEED THROUGH BREAKER FOR 24KW 240V SINGLE PHASE WATER HEATER									
										PANEL E: 14736 14780									
No.	BRKR	A	P	CIRCUIT DESCRIPTION	L	O	M	Wire	CIRC. LOAD	PHASE	CIRC. LOAD	Wire	L	O	M	CIRCUIT DESCRIPTION	BRKR	No.	
1	20	1		RR LIGHTS	13			12	676	2596	1920	6	1			BITTER ROOT OUTLET	20	1	2
3				RR OUTLETS	2			12	360		2280	1920	6	1		CASTLE ROCK OUTLET			4
5				RR OUTLET					180		2100	1920	6	1		WASATCH 3 OUTLET			6
7				SPARE								1920	10	1		SAWTOOTH 1 OUTLET			8
9				SPACE					500	500		1920	10	1		SEWAGE PUMP	20	2	10
11																			12
13																SPACE			14
15																			16
17											12000								18
										TOTALS 16836 16700		AIC 10000							
										3#250MCM + #1 GROUND, FEEDER CU WIRE IN 3" CONDUIT		AMPS/PHASE 140 139		parallel runs 1					

PANEL S	<input checked="" type="checkbox"/> NEW	TYPE	NOOD	1	Ø	3	WIRE	120/240	VOLTS	LOCATION	MOUNTING								
										PAVILION	<input type="checkbox"/> flush <input checked="" type="checkbox"/> surface								
											175 amp. main								
											<input type="checkbox"/> lugs <input checked="" type="checkbox"/> breaker								
										REMARKS									
										PANEL E: 14736 14780									
No.	BRKR	A	P	CIRCUIT DESCRIPTION	L	O	M	Wire	CIRC. LOAD	PHASE	CIRC. LOAD	Wire	L	O	M	CIRCUIT DESCRIPTION	BRKR	No.	
1	70	2		RV PEDESTAL				6	4800	5300	500	12				SEWAGE PUMP	20	2	2
3									6	4800	5300	500	12						4
5	20	1		SPARE												SPARE	70	2	6
7				SPACE															8
9																SPACE			10
11																			12
13																			14
15																			16
17																			18
										TOTALS 5300 5300		AIC 22000							
										3#2/0 + #4 GROUND, FEEDER CU WIRE IN 2" CONDUIT		AMPS/PHASE 44 44		parallel runs 1					

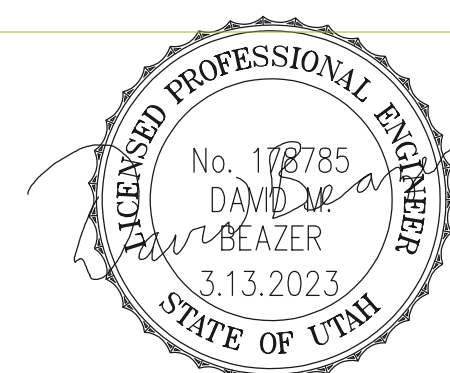

NO.	DATE	DESCRIPTION

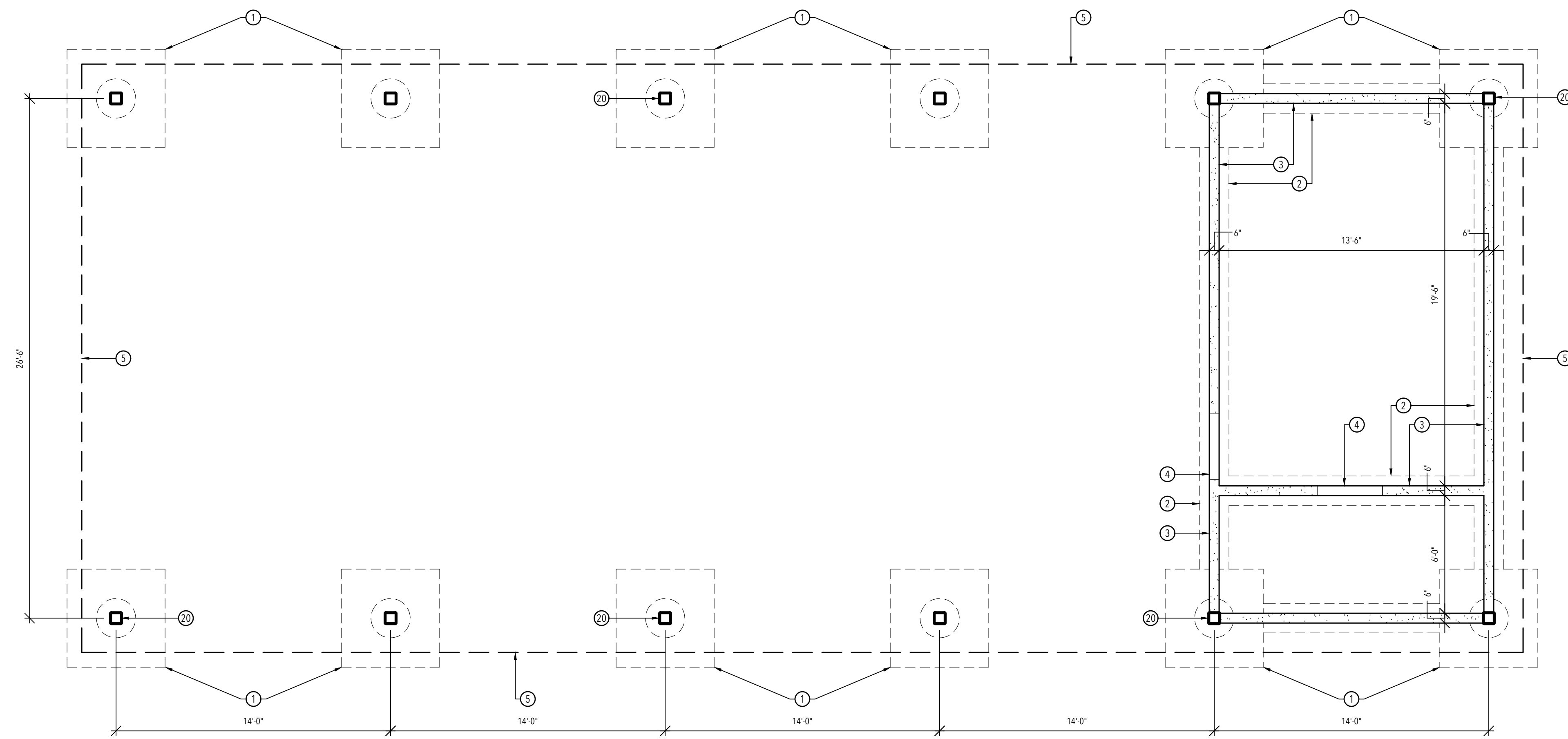

FOOTING & FOUNDATION PLAN

A Scale: 1/4" = 1'-0"

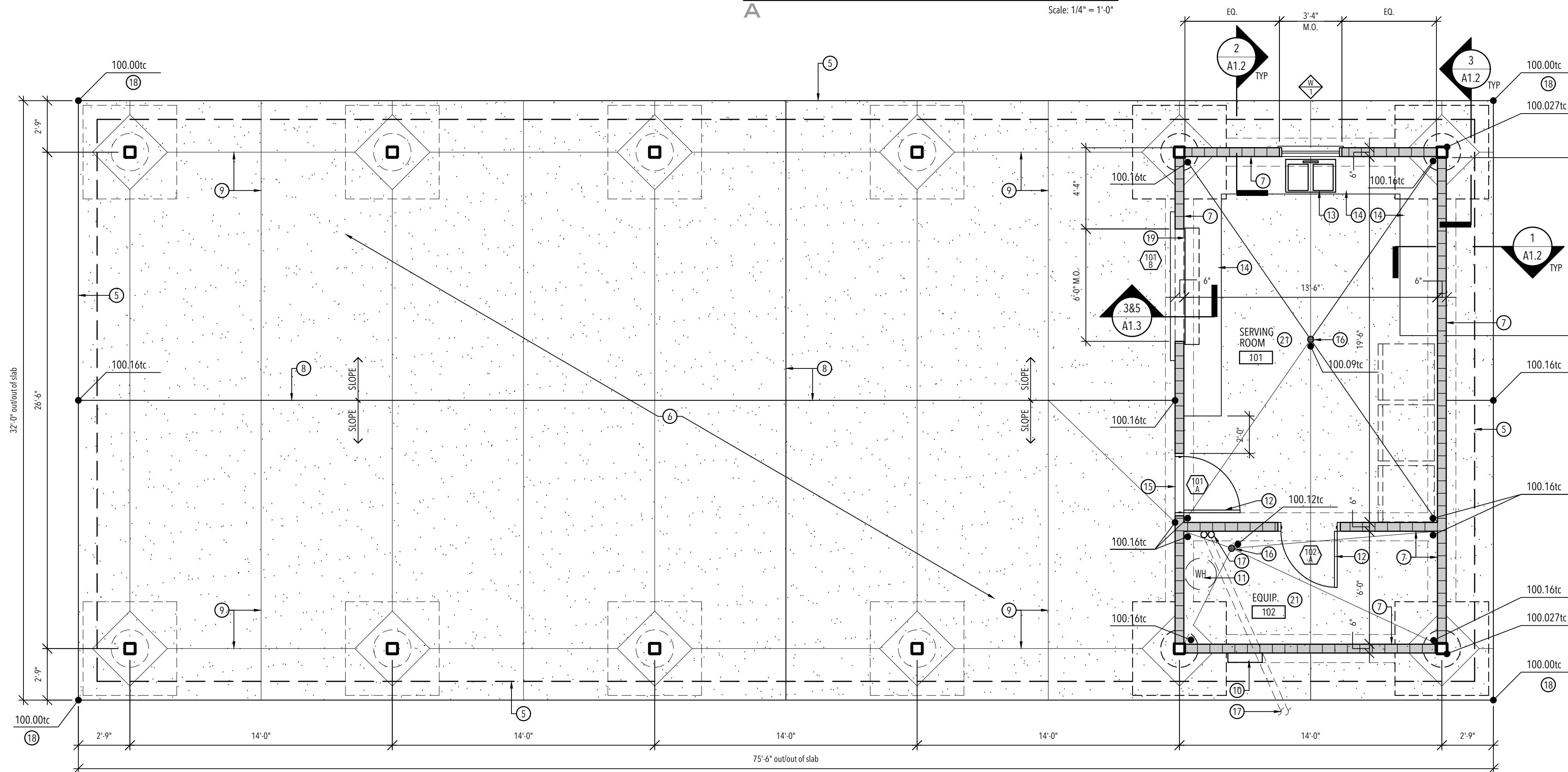

SLAB & FLOOR PLAN

B Scale: 1/4" = 1'-0"

GENERAL NOTES:

- A. Field verify all dimensions and conditions.
- B. The pavilion kit shall be furnished by the Owner and installed by Contractor - re: manufacturer's pavilion drawings.
- C. Fill beneath pavilion shall be compacted granular imported engineered fill per specification.
- D. Contractor is responsible for unloading the pavilion kit at the site from the flat bed delivery truck. Unloading requires a fork lift.
- E. Excess excavated native soil shall not be used beneath the pavilion slab but may be used as grading fill elsewhere on site. Slope grade away from the pavilion for 8 feet minimum on all sides and provide compacted granular road base for top 6 inches in this 8 foot perimeter. Any remaining excess native soil may be used as fill elsewhere on the property as directed by the owner.

KEYED NOTES:

- 1. 5'-0" x 5'-0" x 1'-0" reinforced concrete footing and concrete pier (typical of 12) - Re: manufacturer's pavilion drawings.
- 2. Typical reinforced concrete spread footing - re: 1&2/A1.2.
- 3. Typical foundation wall - re: 1&2/A1.2.
- 4. Step foundation wall down 6" below top of slab where door occurs. Pour slab over.
- 5. Edge of roof.
- 6. 4" concrete slab with 6"x 6" #10 welded wire mesh reinforcing over 4" gravel base and engineered granular fill to prepared subgrade. Thicken slab edges to 8" and reinforce - Re: manufacturer's pavilion drawings.
- 7. 6" colored CMU with #4 bar vertical reinforcing at 32" o.c. and #5 bar horizontal reinforcing at 24" o.c. - Re: structural elevations, sheet A1.2.
- 8. Expansion joint with sealant.
- 9. Control joint (typical).
- 10. Electrical panel - Re: electrical.
- 11. Electric water heater - Re: plumbing.
- 12. Hollow metal door and frame, paint.
- 13. Stainless steel 2-compartment sink - re: plumbing.
- 14. Stainless steel countertop - Re: 8/A1.2.
- 15. Metal threshold - re: 7/A1.2.
- 16. Floor drain - re: plumbing. Concrete floor slab in this room slopes to drain at 1/8" foot.
- 17. Two 4" diameter empty conduits for future use, cap conduits 6" above floor and at edge of concrete slab.
- 18. Top of slab elevation at edge=100.00. See civil drawings for actual elevation.
- 19. Steel coiling counter door, powder-coat finish.
- 20. HSS column on concrete pier and footing - re: 3/A1.2 (typ.)
- 21. Provide 1/2" expansion joint (with sealant) at perimeter walls in this room.

PAVILION KIT NOTES

- 1. Pavilion shall be constructed/erected using the pavilion manufacturer's approved project-specific construction drawings.
- 2. Metal components of the pavilion are factory finished however some touch-up may be necessary.
- 3. Summary of owner-furnished items:

The pavilion kit is to be furnished by the owner from Smith Steel Works. This includes, but is not limited to, the following:

Item	Furnished by	Erected/installed by
Structural steel columns	Owner	Contractor
Steel roof beams	Owner	Contractor
Mega-Rib metal roofing	Owner	Contractor
Anchor bolts	Owner	Contractor

Other materials are to be furnished by the contractor. These items include but are not limited to, the following:

Item	Furnished by	Erected/installed by
Concrete work	Contractor	Contractor
Steel reinforcing (rebar & WWM)	Contractor	Contractor

NO.	DATE	DESCRIPTION

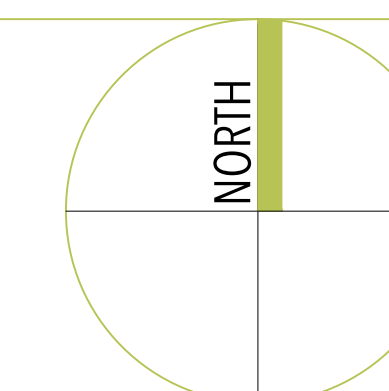

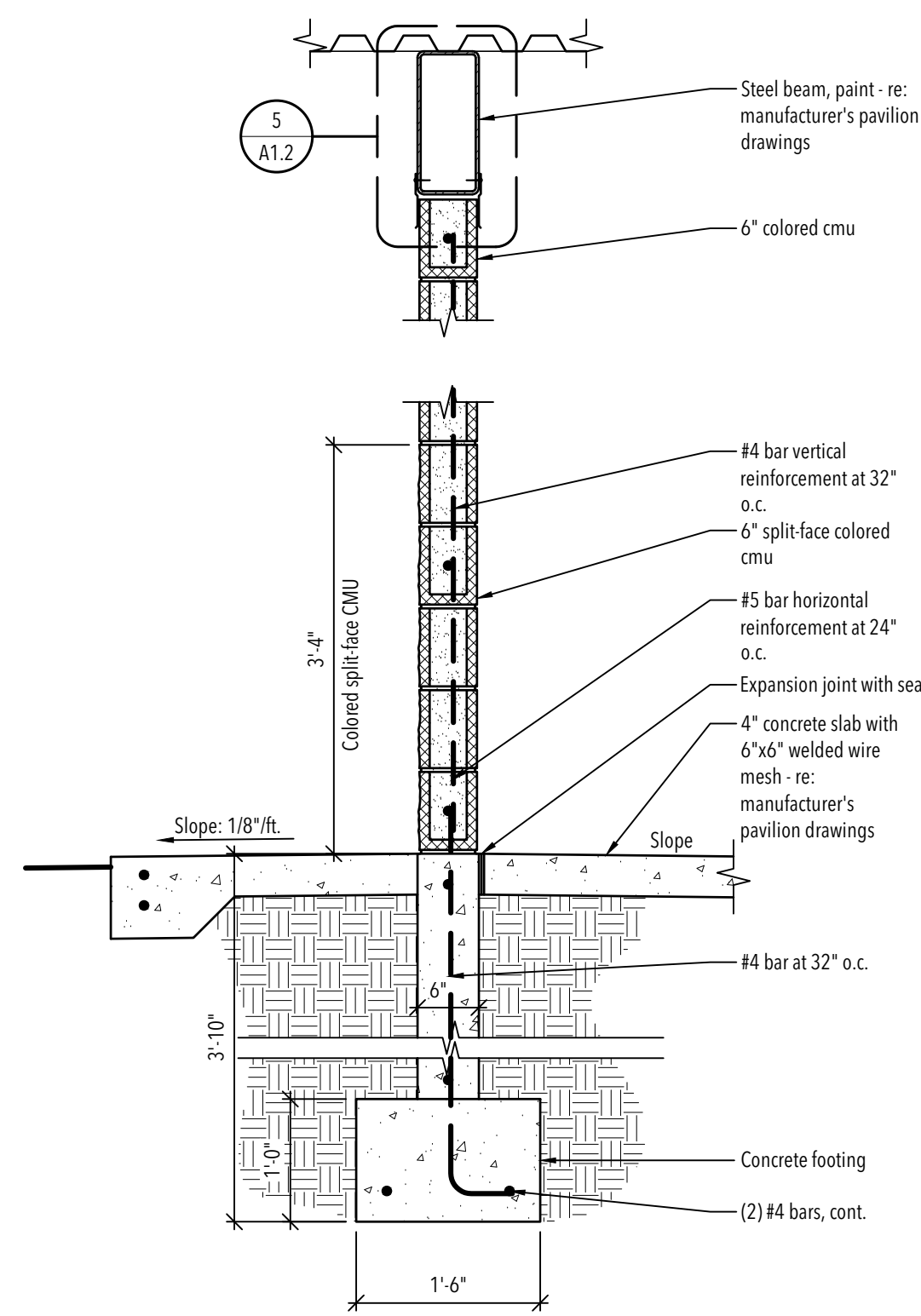

WALL SECTION

1 Scale: 3/4" = 1'-0"

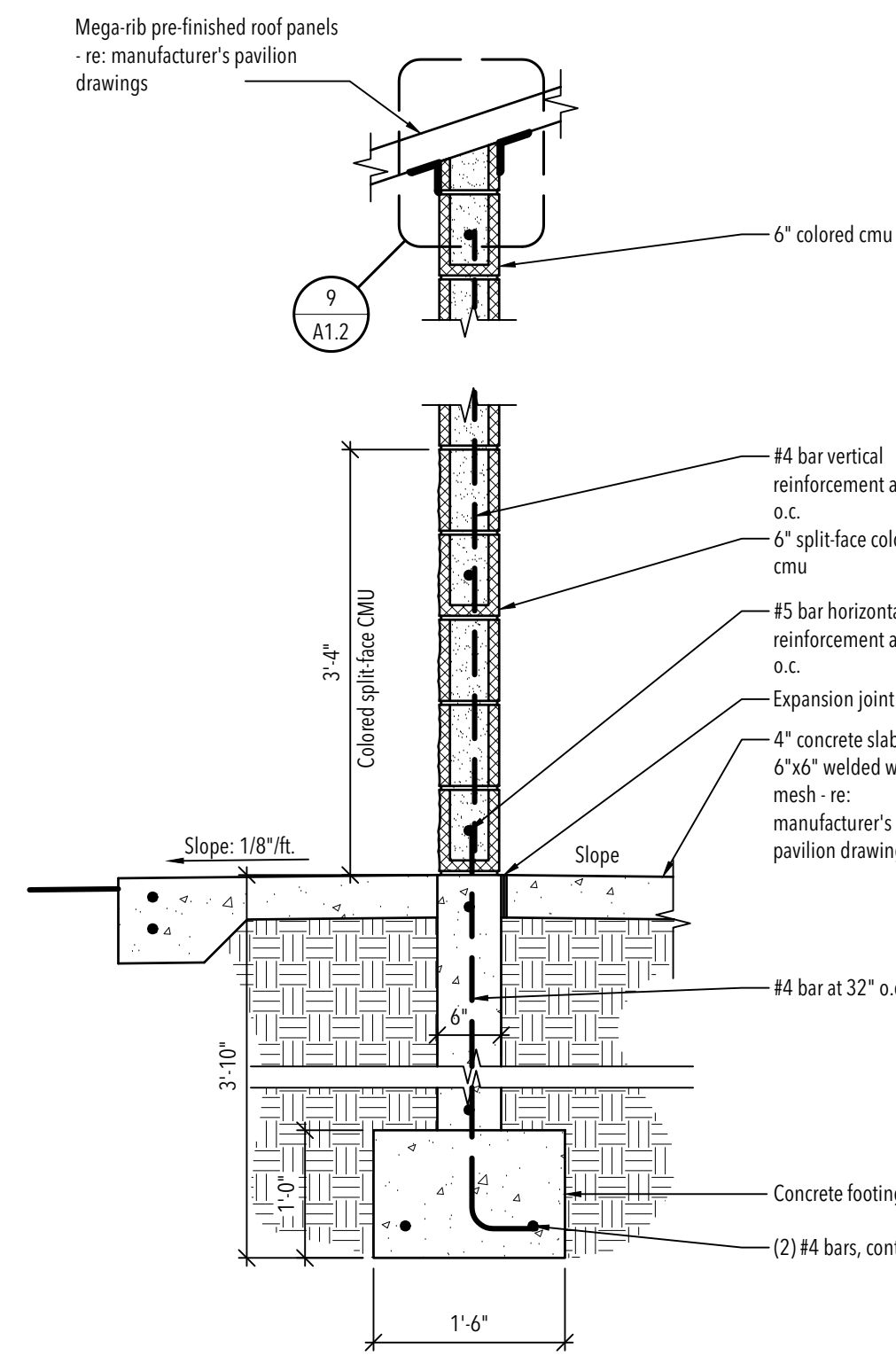

WALL SECTION

2 Scale: 3/4" = 1'-0"

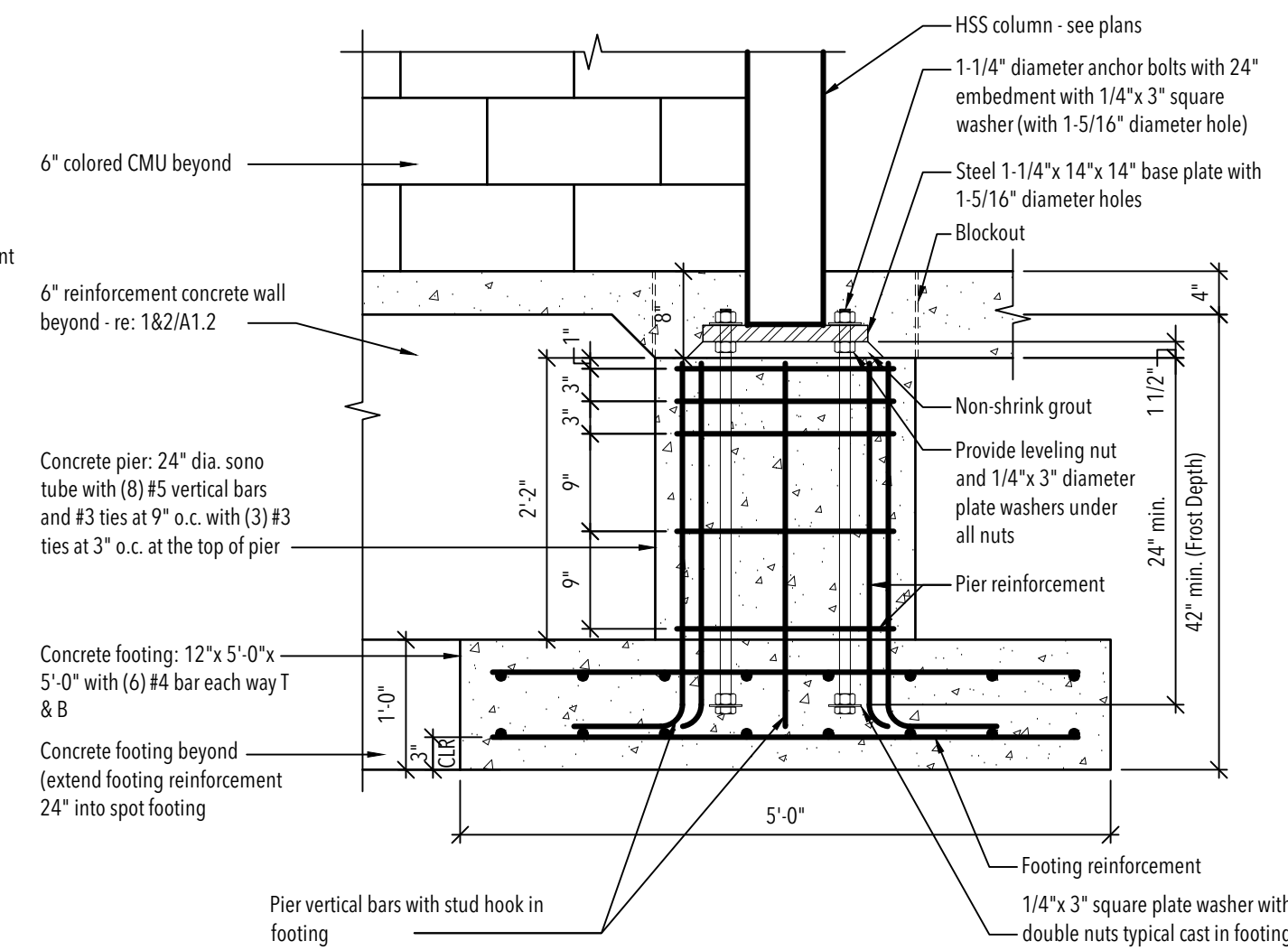

PIER AND FOOTING DETAIL

3 Scale: 3/4" = 1'-0"

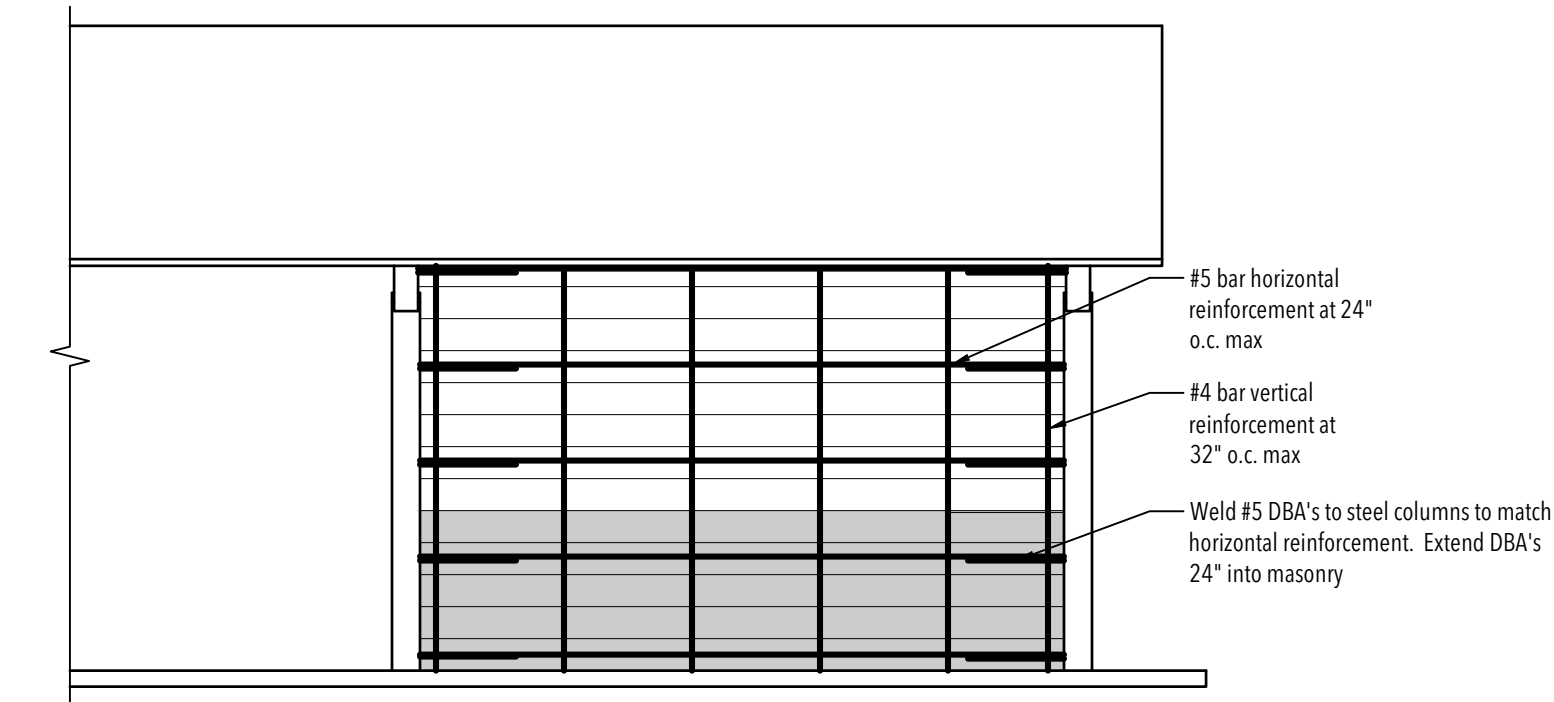

STRUCTURAL REINFORCEMENT ELEVATION (TYPICAL SIDEWALL)

A Scale: 1/4" = 1'-0"

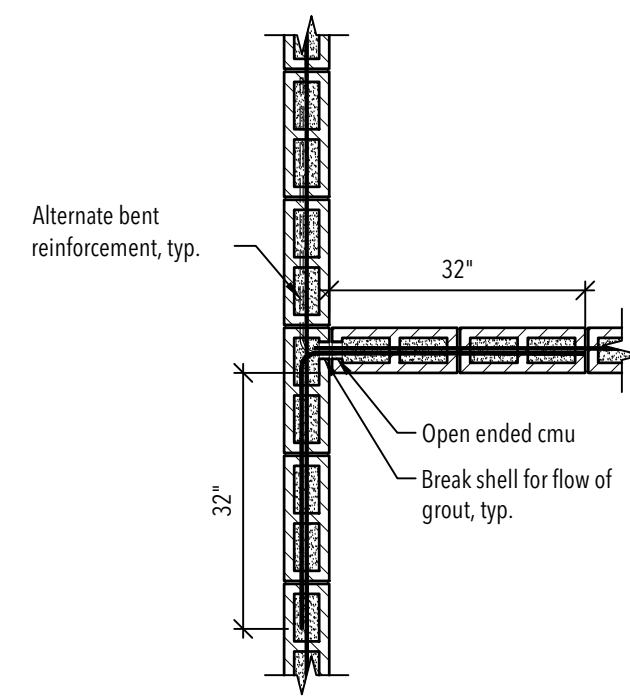

TYPICAL REINFORCEMENT AT INTERSECTIONS IN MASONRY DETAIL

4 Scale: 1/2" = 1'-0"

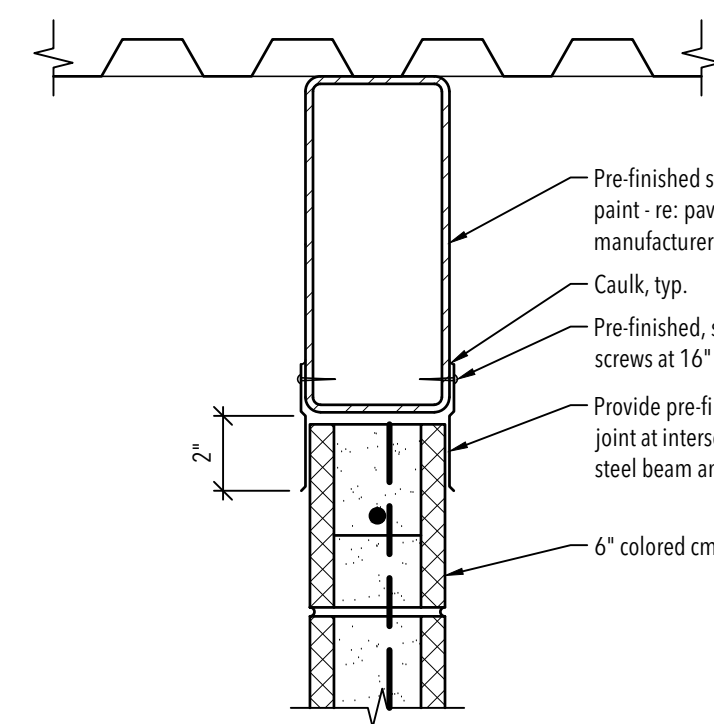

SLIP JOINT DETAIL

5 Scale: 1 1/2" = 1'-0"

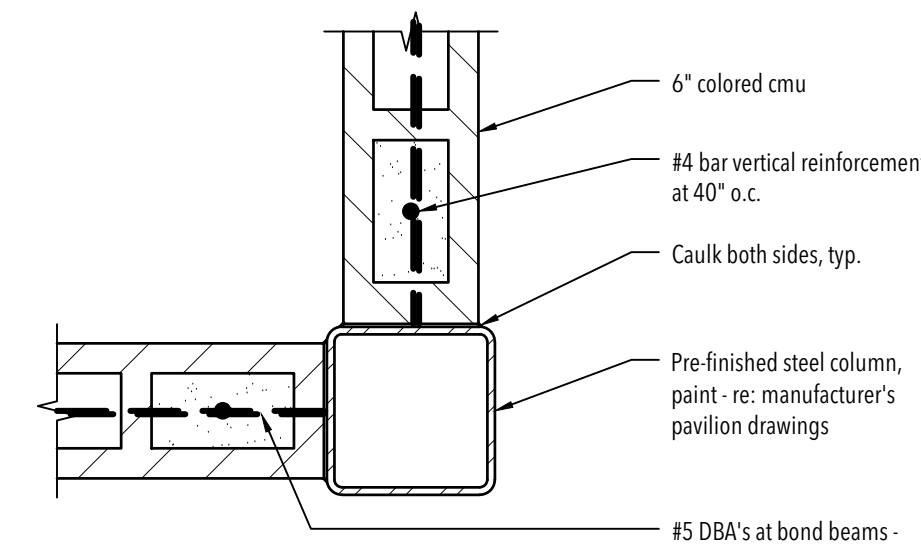

CORNER DETAIL

6 Scale: 1 1/2" = 1'-0"

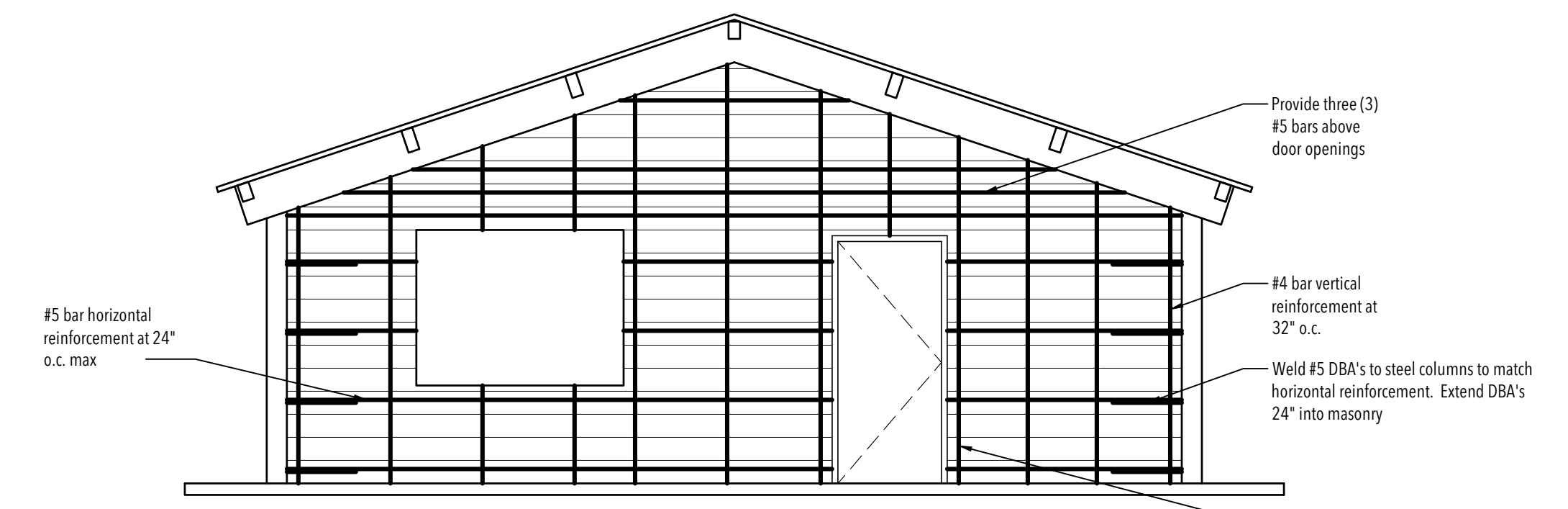

STRUCTURAL REINFORCEMENT ELEVATION (TYPICAL GABLE WALL)

B Scale: 1/4" = 1'-0"

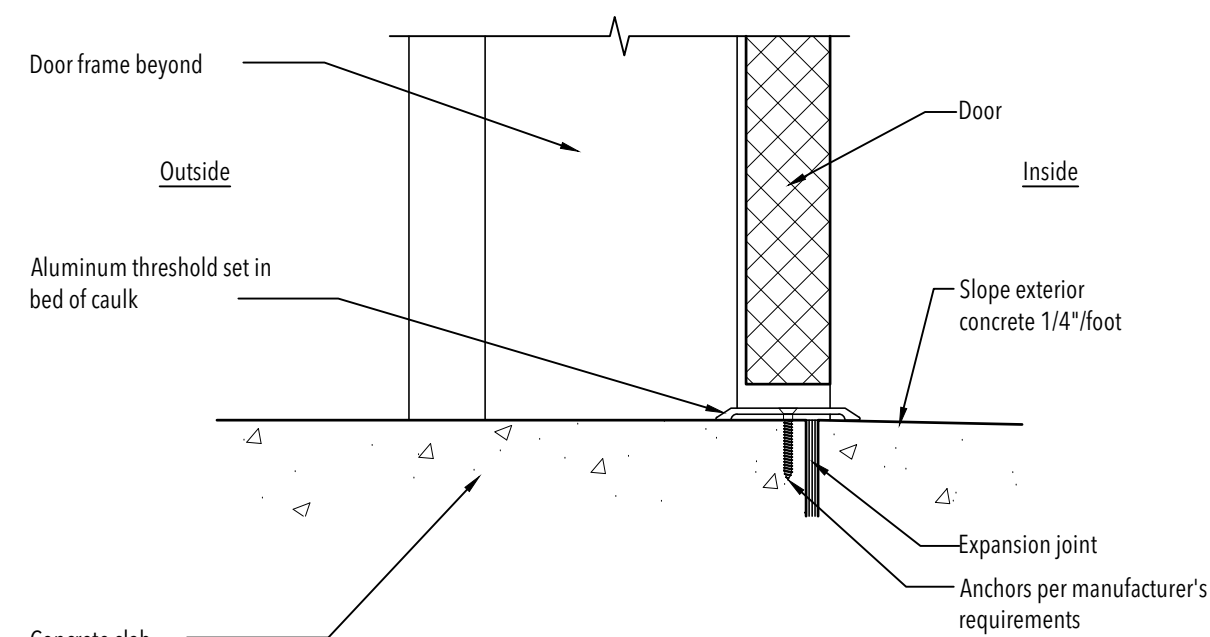

THRESHOLD DETAIL

7 Scale: 3" = 1'-0"

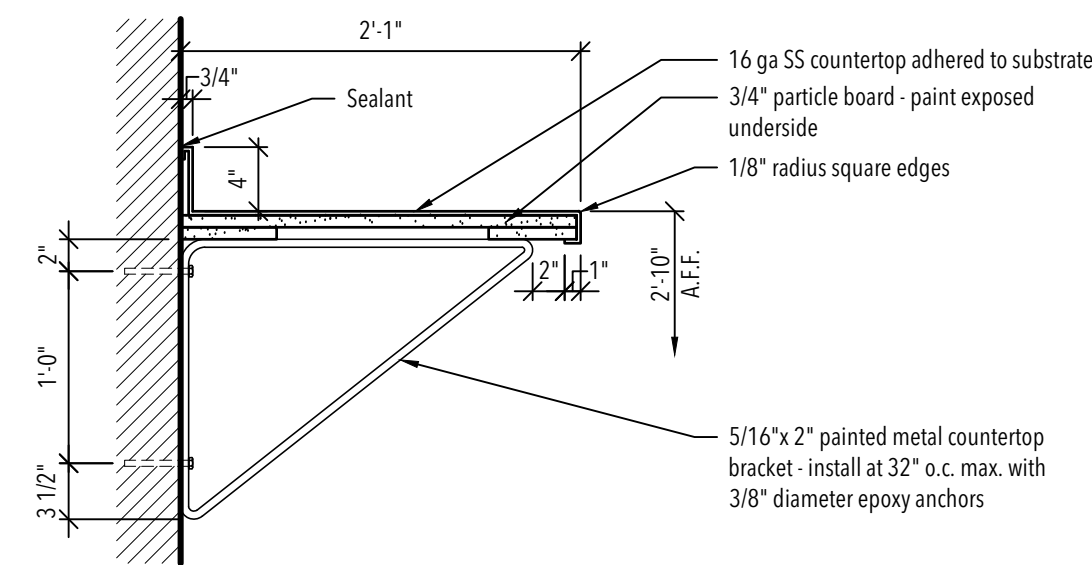

COUNTERTOP SECTION

8 Scale: 1" = 1'-0"

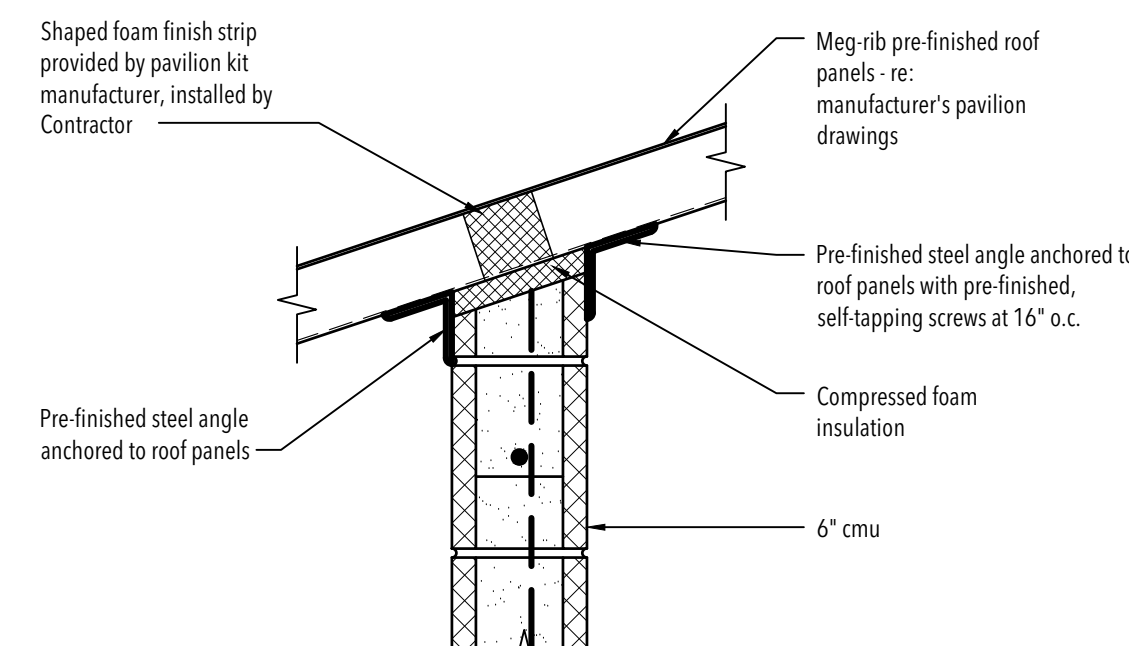

WALL DETAIL

9 Scale: 1 1/2" = 1'-0"

NO.	DATE	DESCRIPTION

ROOM FINISH SCHEDULE									
ROOM NO.	ROOM DESIGNATION	FLOOR	BASE	WALLS	CEILING	CLG. HT.	SPECIALTIES	REMARKS	ROOM NO.
101	Serving room	F1	B1	W1	C1	Varies	S2	--	101
102	Equipment	F1	B1	W1	C1	Varies	S1, S2	--	102

ROOM FINISH KEY									
FLOOR		BASE		WALLS		CEILING		SPECIALTIES	
F1	Concrete floor, epoxy paint	B1	3/4" epoxy grout cove	W1	CMU walls, block filler and epoxy paint	C1	Exposed structure	S1	Electric water heater
								S2	HM door & frame, paint

DOOR SCHEDULE																				
NO.	ROOM NAME	DOOR							FIRE RATING (MIN)	FRAME					DETAILS			HDWR. GROUP	REMARKS	NO.
		WIDTH	HEIGHT	THICK.	TYPE	CONST.	FINISH	GLASS		WIDTH	TYPE	CONST.	SIDELITE	TRANSOM	HEAD	JAMB	THRESH.			
101A	SERVING RM 101	3'-0"	7'-0"	1-3/4"	A	metal	paint	--	6-3/4"	1	h.m.	--	--	1/A1.3	2/A1.3	7/A1.2	P1	--	101A	
101B	SERVING RM 101	6'-0"	4'-6"	--	B	metal	powder coat	--	n/a	2	metal	--	--	3/A1.3	4/A1.3	5/A1.3 (Sill)	*	Locking cylinder keyed to match door 101A	101B	
102A	EQUIP. 102	3'-0"	7'-0"	1-3/4"	A	metal	paint	--	6-3/4"	1	h.m.	--	--	1/A1.3	2/A1.3	--	P22	--	102A	

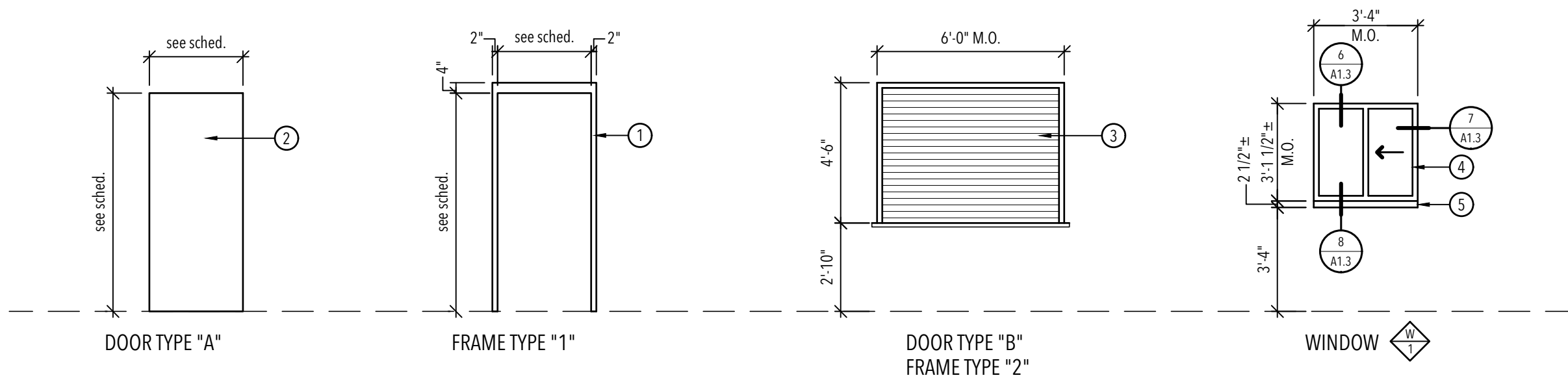

- KEYED NOTES:**
- Hollow metal frame, paint.
 - Metal door, paint.
 - Steel coiling door, powder coat paint.
 - Aluminum window (slider) with tempered insulated glass.
 - Pre-cast window sill.

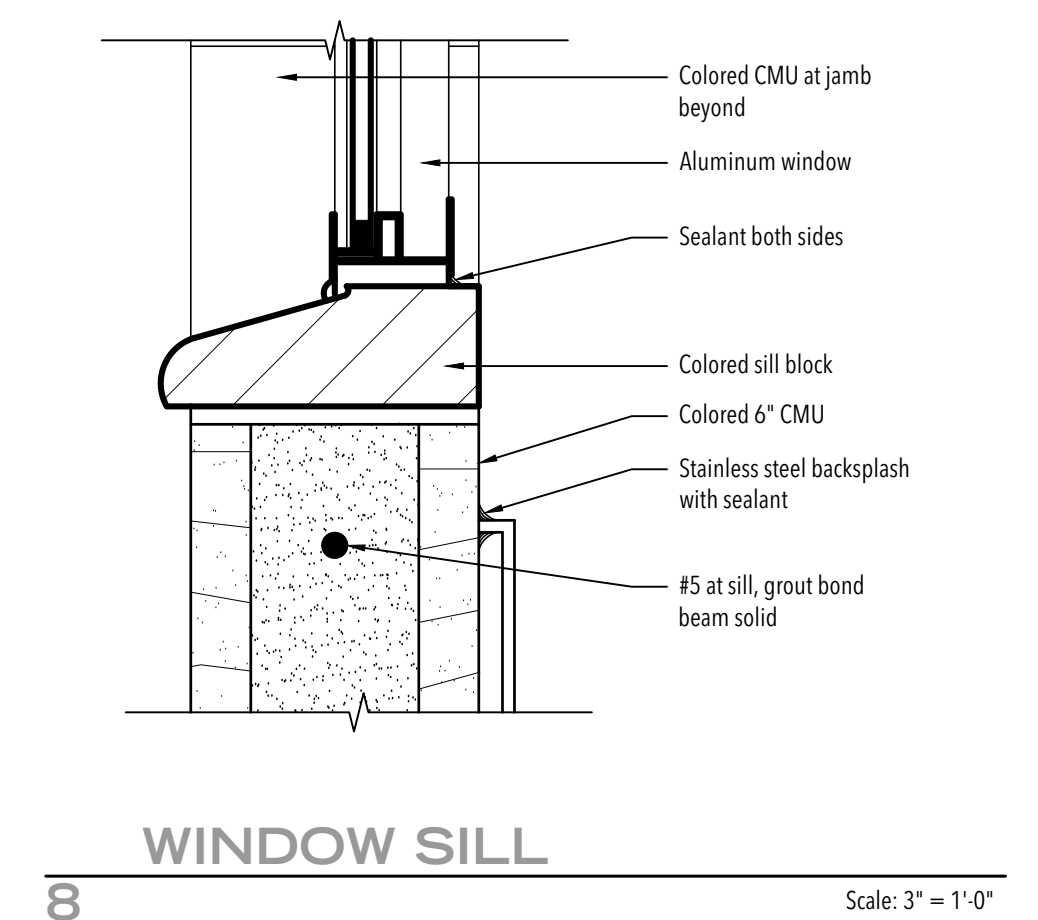
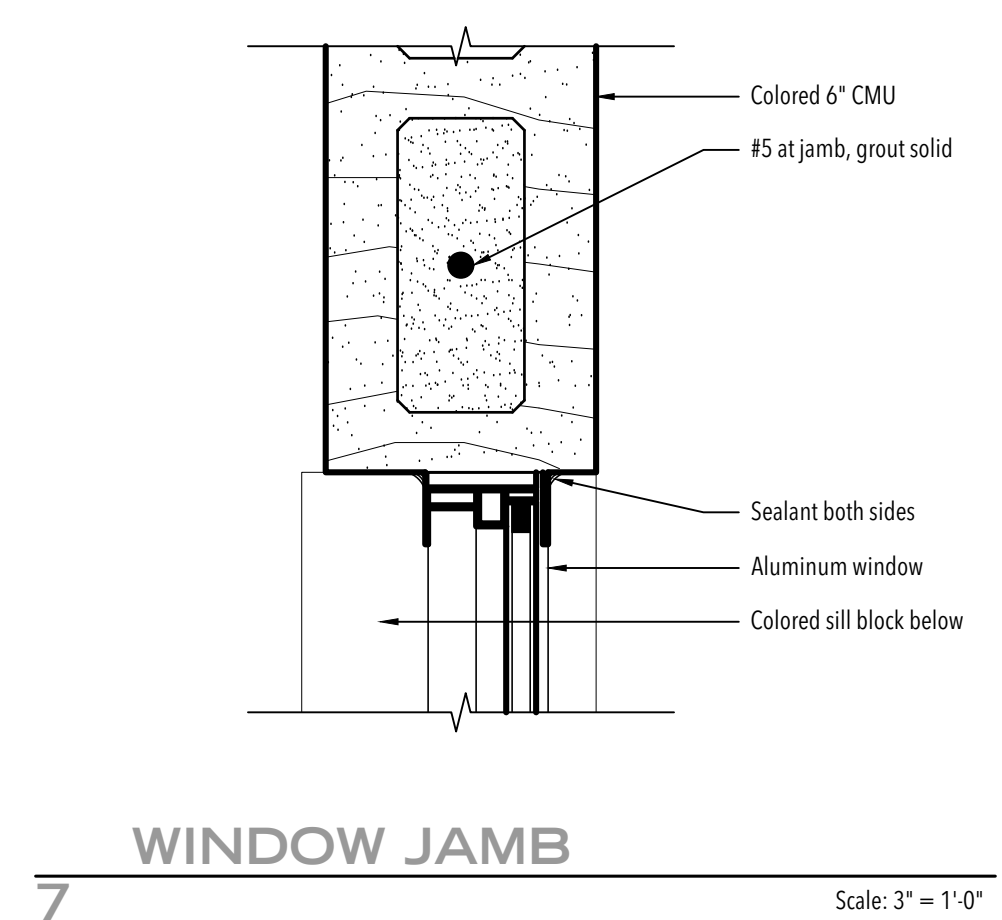
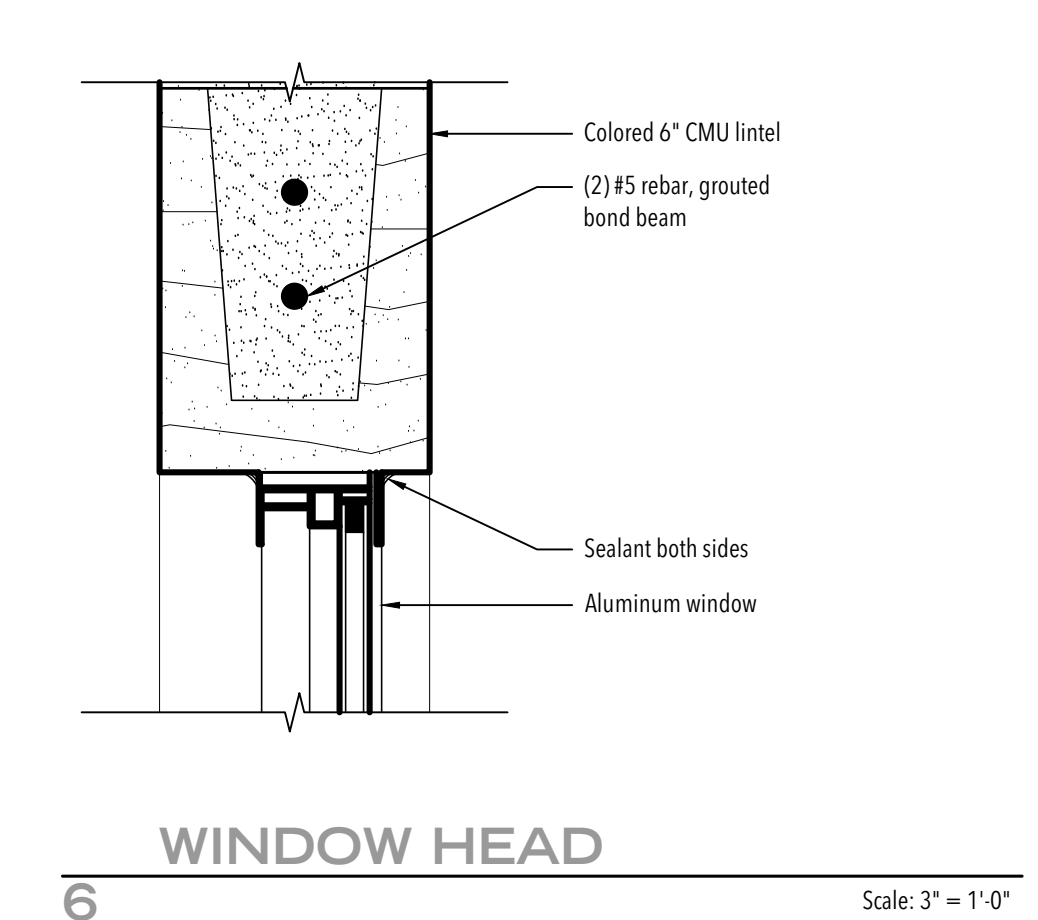
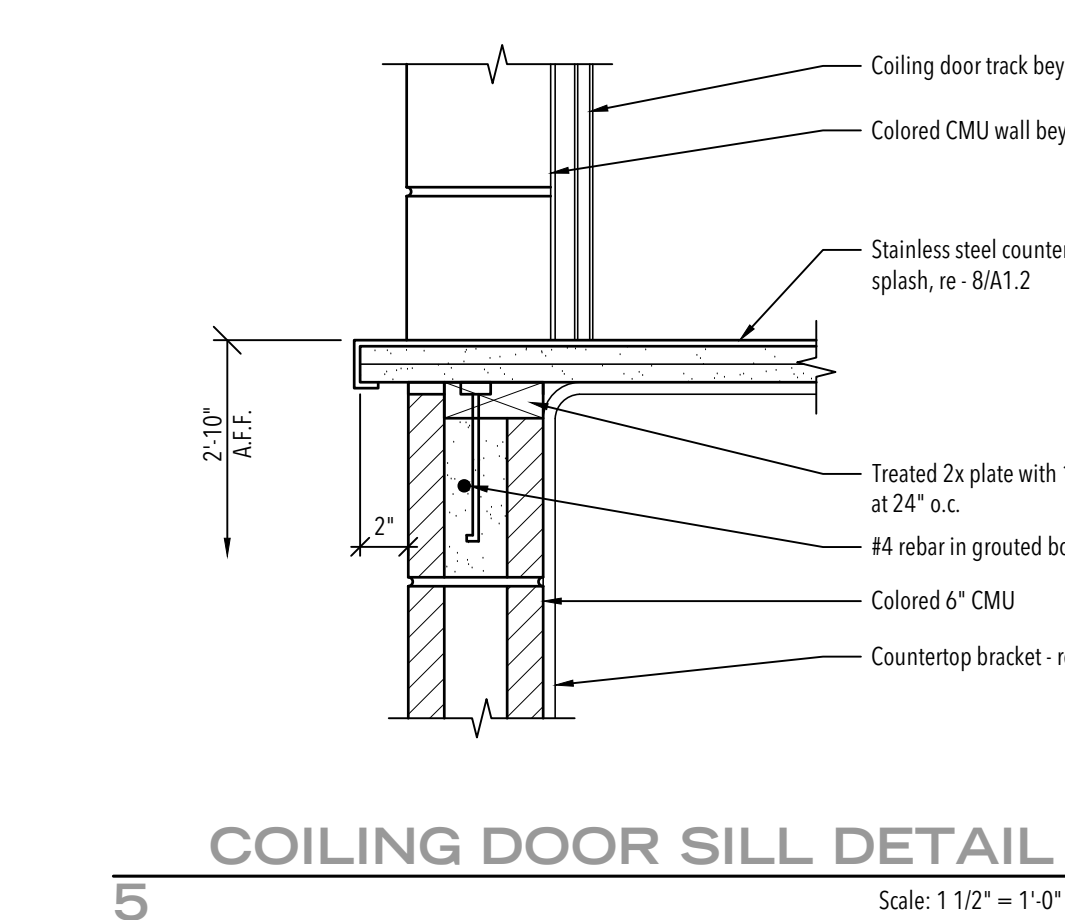
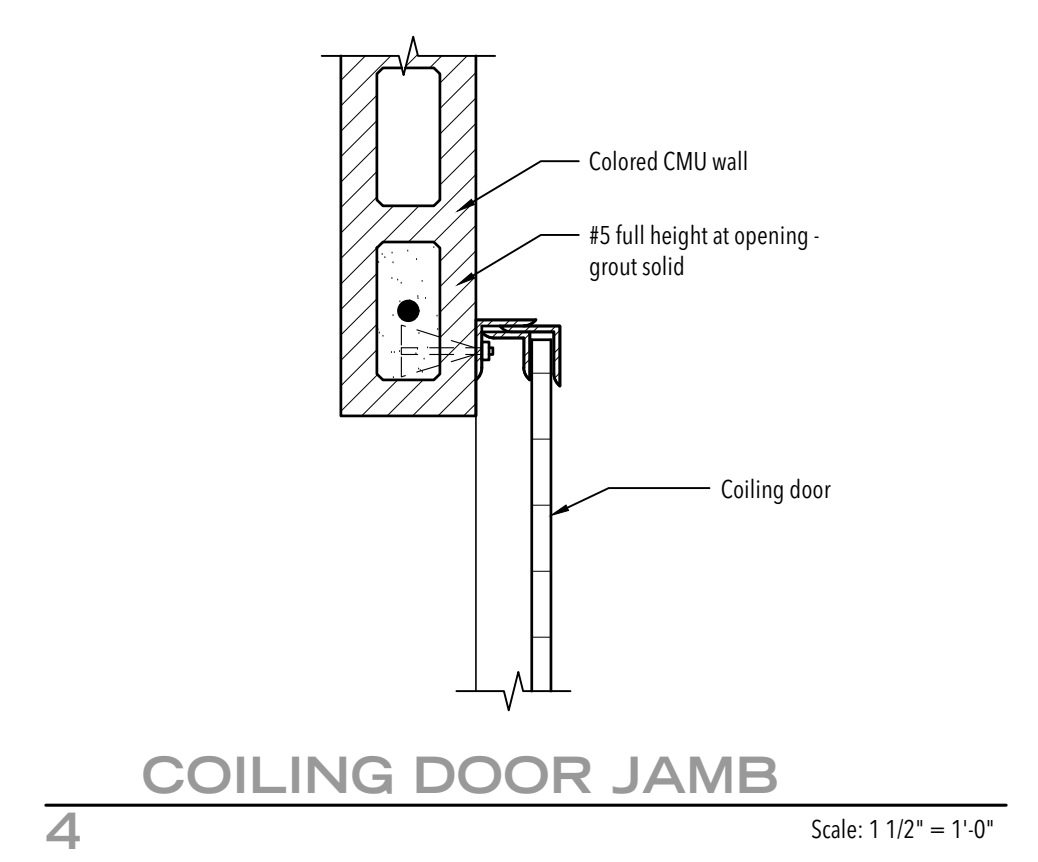
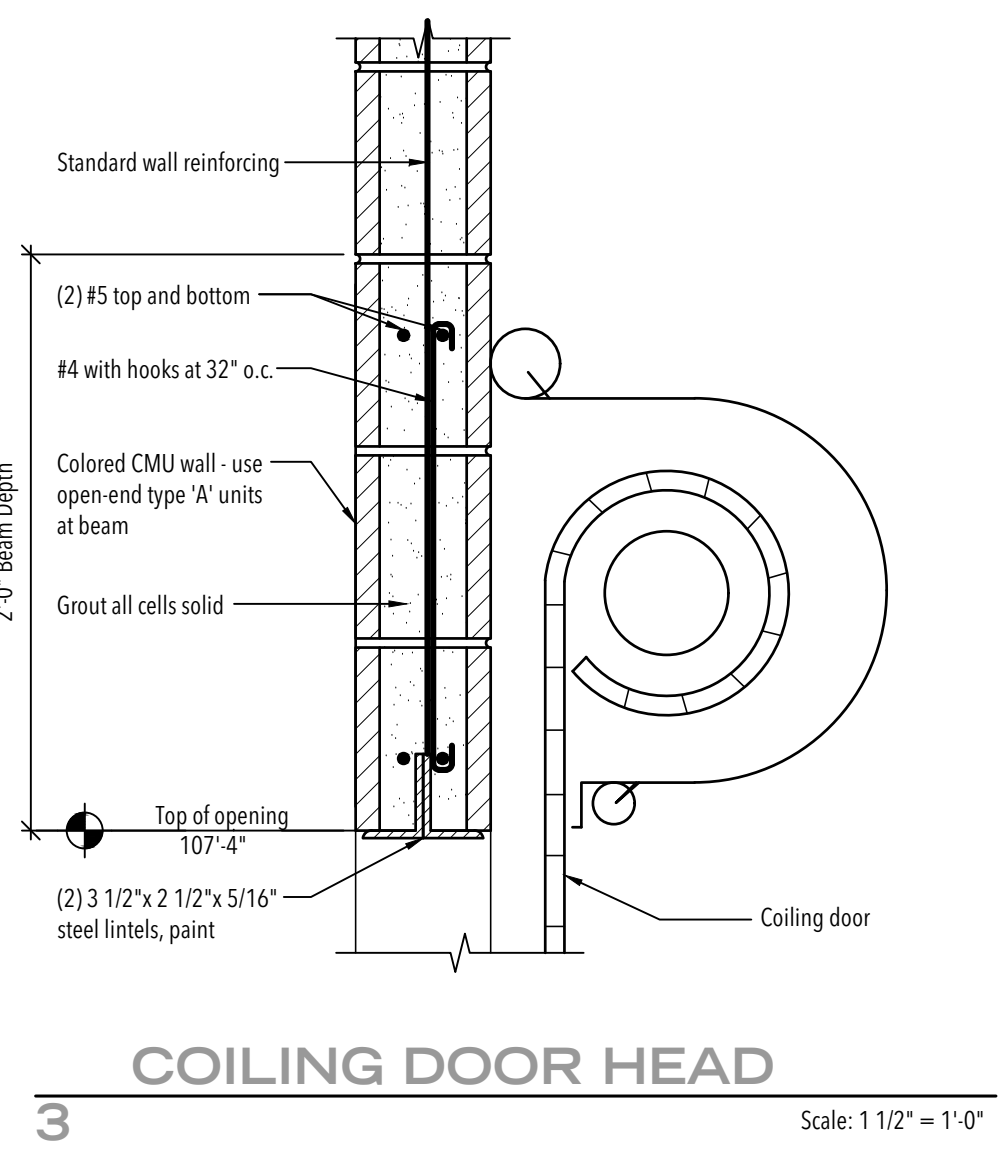
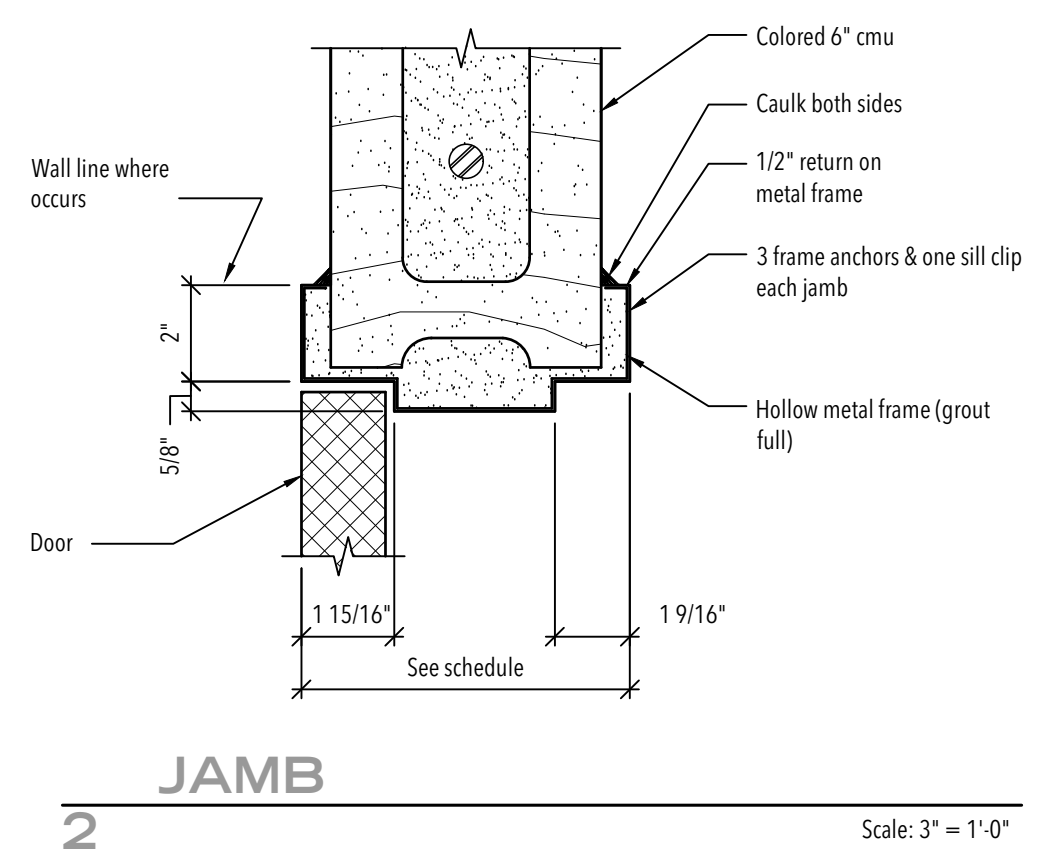
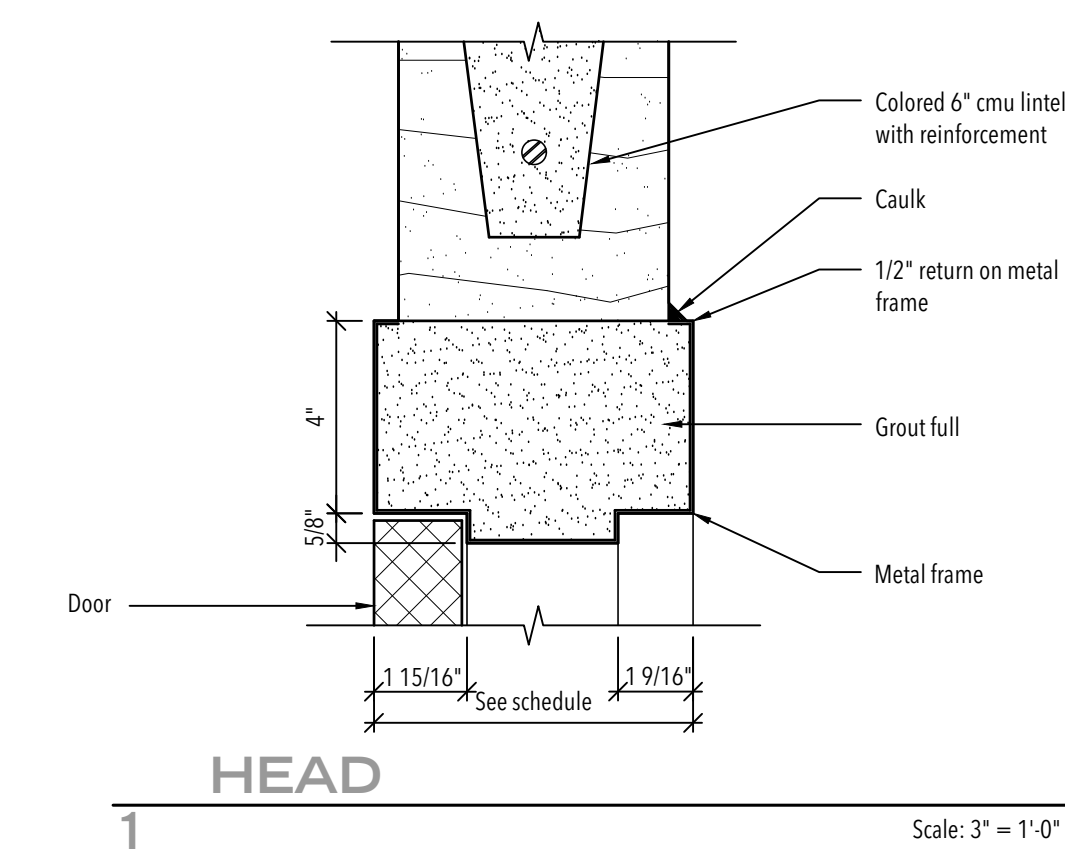

STUDIO 333 ARCHITECTS
333 24TH STREET
OGDEN, UT 84401
801.394.3033

LICENSED ARCHITECT
NO. AR 984269

Tony K. Pantone
TONY K. PANTONE
STATE OF IDAHO

CAMP HULL VALLEY IMPROVEMENTS
10100 EAST CUB RIVER RD.
PRESTON, IDAHO

NO.	DATE	DESCRIPTION

DATE: 03.15.23
PROJECT NUMBER: 2223
PROPERTY NUMBER: 501-737121050101
SCALE: VARIES

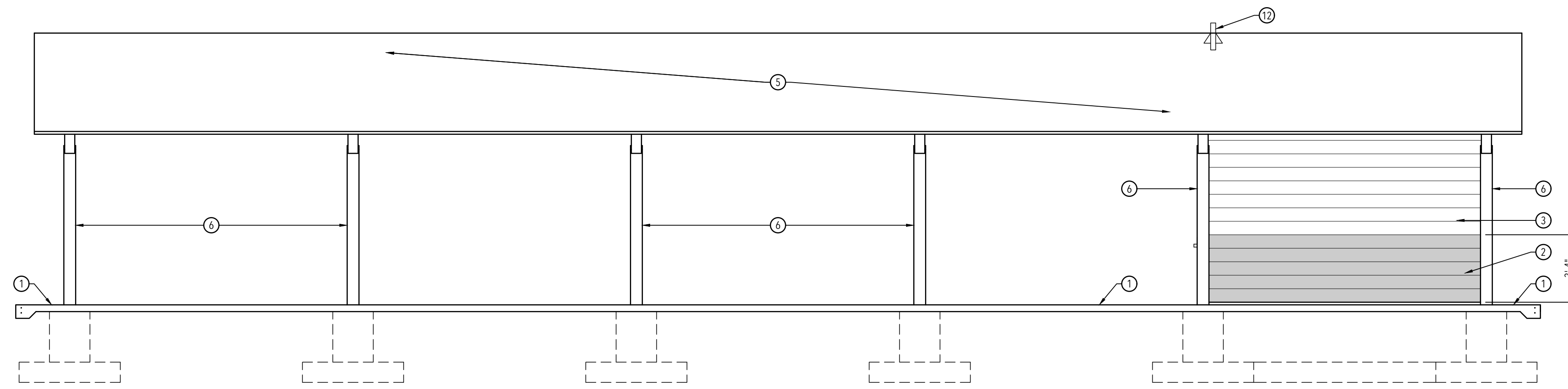

ELEVATION A
Scale: 1/4" = 1'-0"

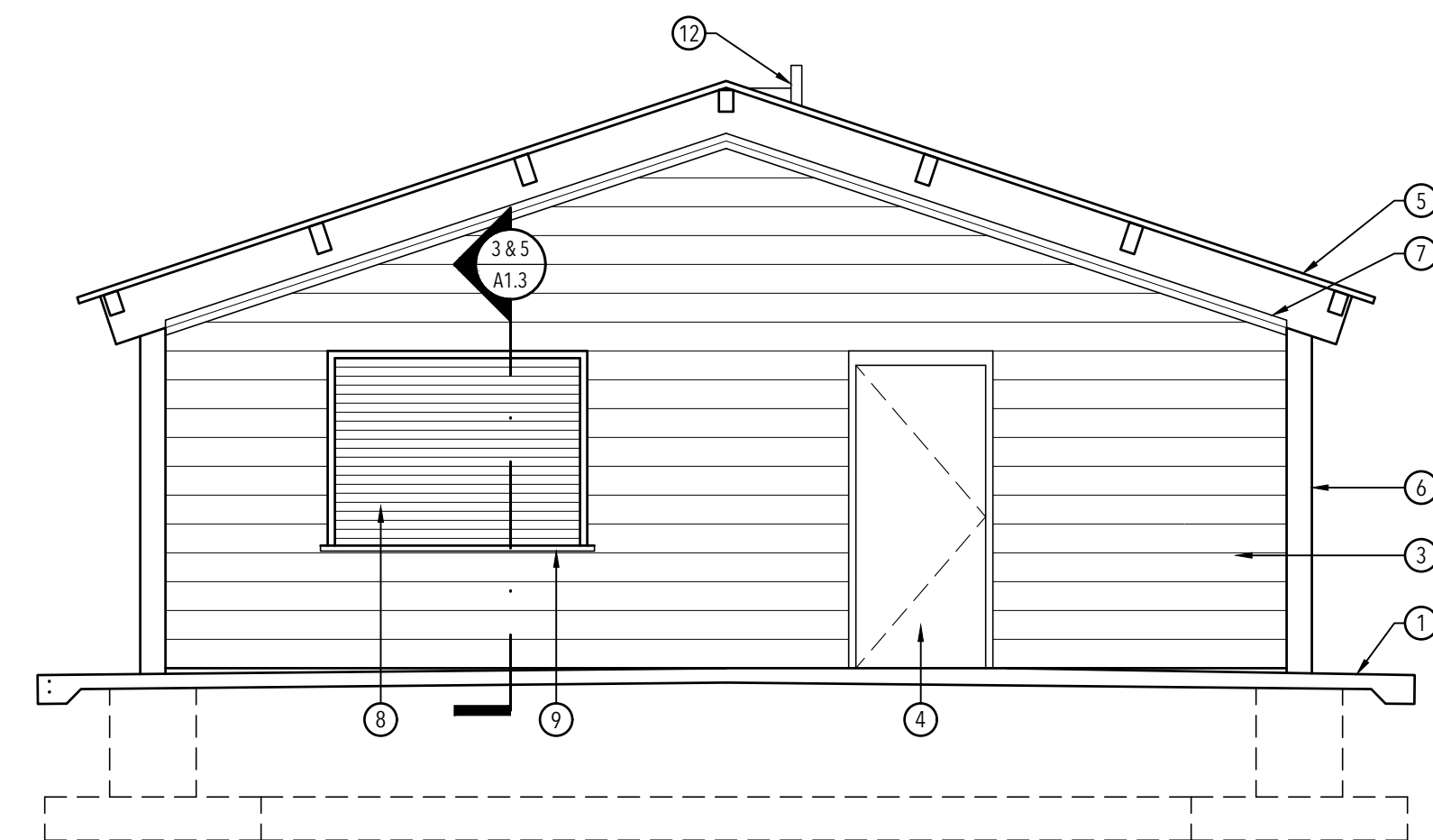

ELEVATION B
Scale: 1/4" = 1'-0"

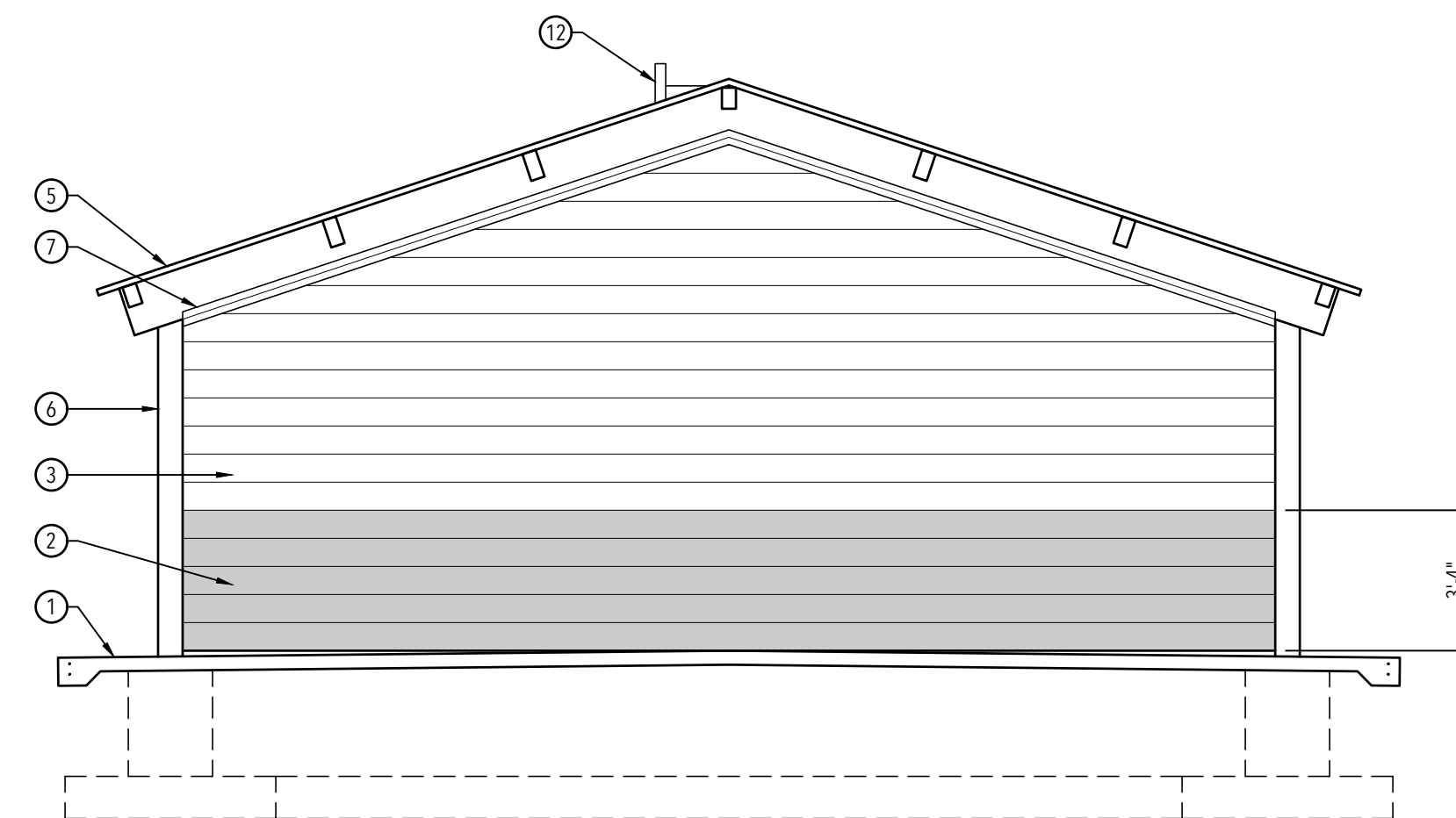

ELEVATION C
Scale: 1/4" = 1'-0"

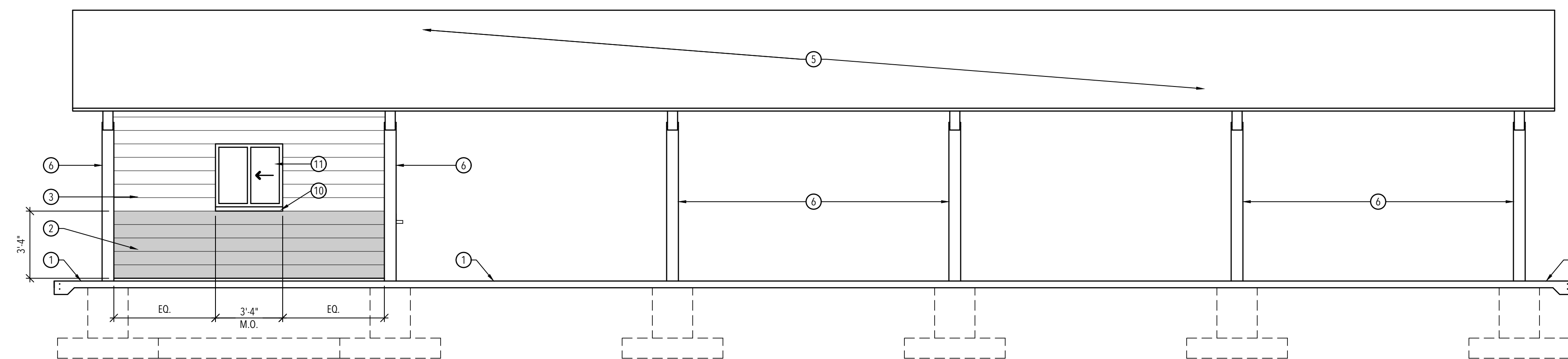

ELEVATION D
Scale: 1/4" = 1'-0"

- GENERAL NOTES:**
- Field verify all dimensions and conditions.
 - The pavilion kit shall be furnished by the Owner and installed by Contractor - re: manufacturer's pavilion drawings.
 - Fill beneath pavilion shall be compacted granular imported engineered fill per specification.
 - Flash plumbing vent through the roof using 24 ga. galvanized steel base with non-fading, sealing, elastomer collar.
 - Before installing deck edge metal caps on eaves of pavilion roof, obtain Architect's approval to do so (this item might be omitted).

- KEYED NOTES:**
- 4" concrete slab with 6"x6" welded wire mesh. Reinforce and thicken slab edges to 8" - re: manufacturer's pavilion drawings.
 - 6" colored CMU (shaded), color #2.
 - 6" colored CMU, color #1.
 - Hollow metal door and frame, paint.
 - 1-1/2"x 24 ga. mega-rib pre-finished roof panels - re: manufacturer's pavilion drawings.
 - Pre-finished steel column - re: manufacturer's pavilion drawings.
 - Metal slip joint - re: 5/A1.2.
 - Pre-finished metal ceiling door.
 - Stainless steel countertop from serving room continue through opening.
 - Precast window sill.
 - Aluminum slider window with tempered insulated glass.
 - Vent pipe through roof with metal snow cricket.

NO.	DATE	DESCRIPTION

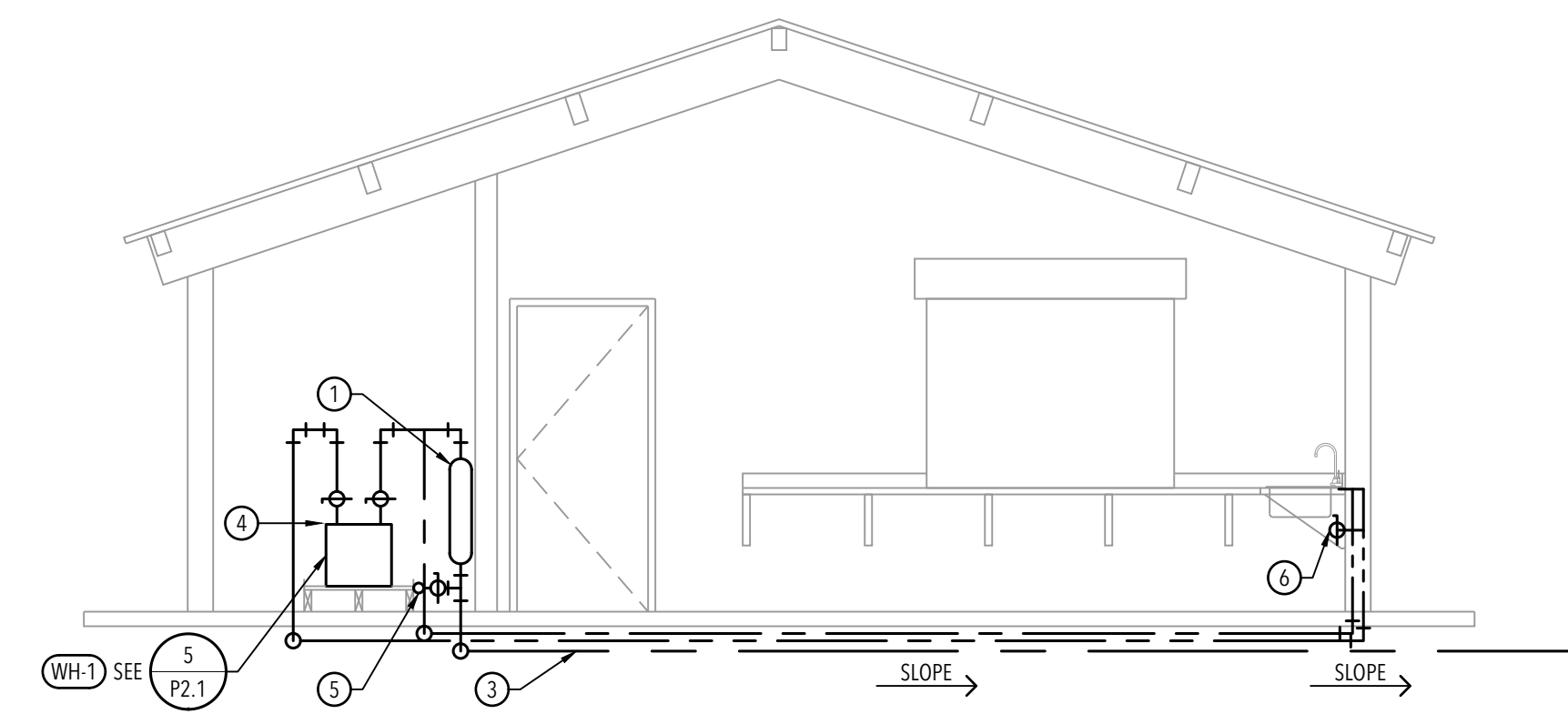

SECTION B
Scale: 1/4" = 1'-0"

KEYED NOTES:

1. Backflow preventer - re: 6/P2.1.
2. Drain valve with ball valve and threaded connection.
3. Slope 1" C.W. line back to stop and waste valve.
4. Ball valve shut off.
5. Ball valve with threaded cap and chain stay - re: 9/P2.1.
6. Ball valve with threaded cap and chain stay below countertop for both cold and hot water - re: 9/P2.1.

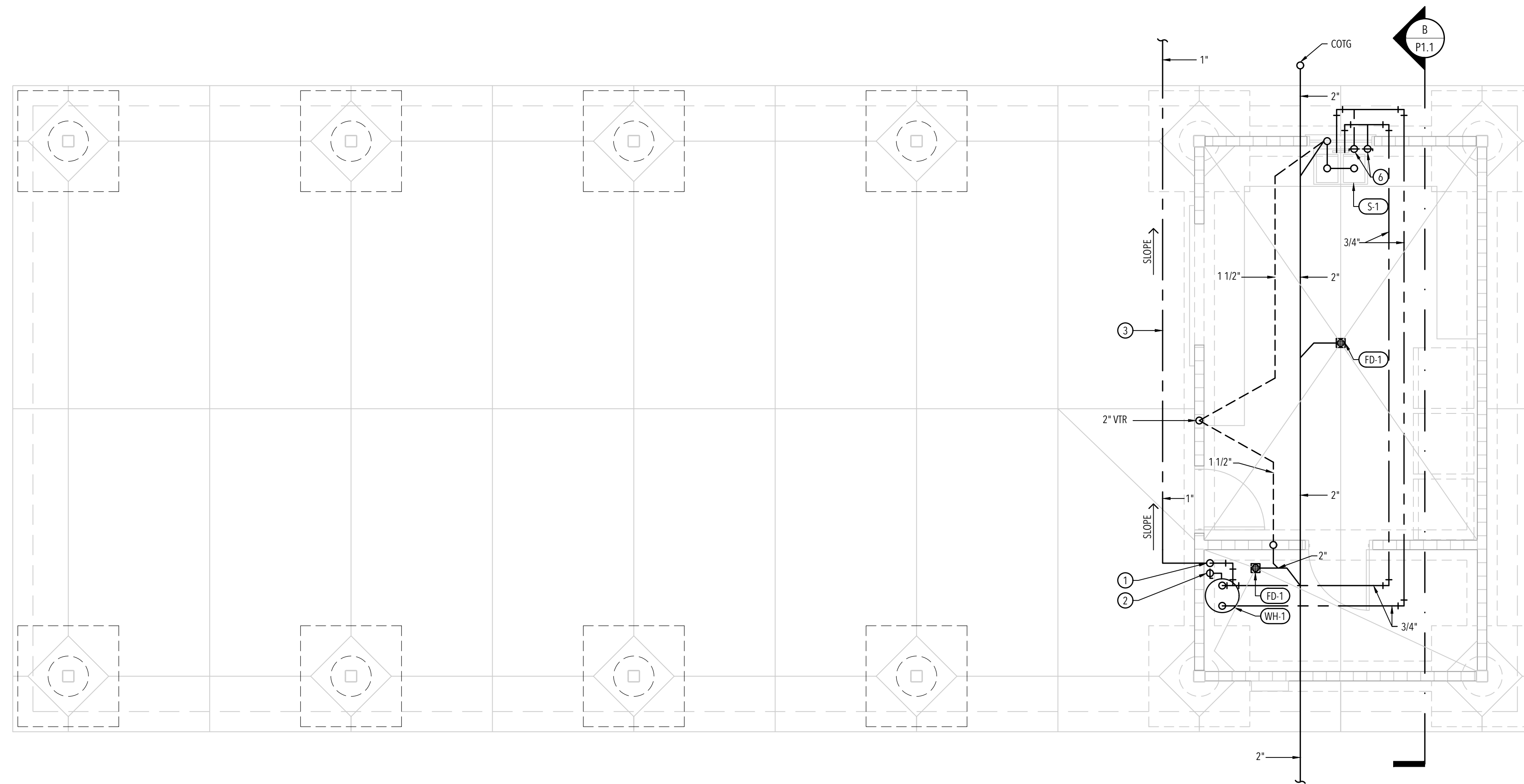

PLUMBING PLAN A
Scale: 1/4" = 1'-0"

MARK	FIXTURE	PIPE SIZE					REMARKS	A.D.A
		TRAP	WASTE	VENT	C.W.	H.W.		
S-1	Sink	1-1/2"	1-1/2"	1-1/4"	1/2"	1/2"	Double compartment	Ⓜ
FD-1	Floor drain	2"	2"	1-1/2"			With trap guard see detail 7/P2.1	
WH-1	Water heater				1"	1"	Electric, 1500 W, 120V, 1 phase 20 gallon capacity Manufacturer: Rheem Model: PROE20-1-RH-POU	

Ⓜ When mounted per architectural elevation A.D.A. requirements are met.
Ⓜ Denotes fixture for people with disabilities.

NO.	DATE	DESCRIPTION

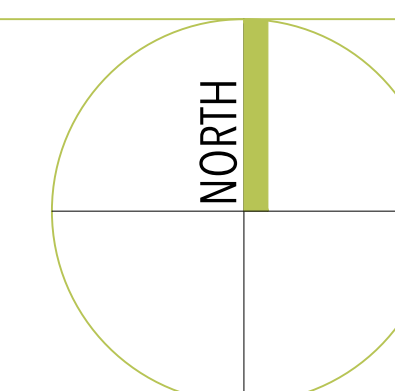

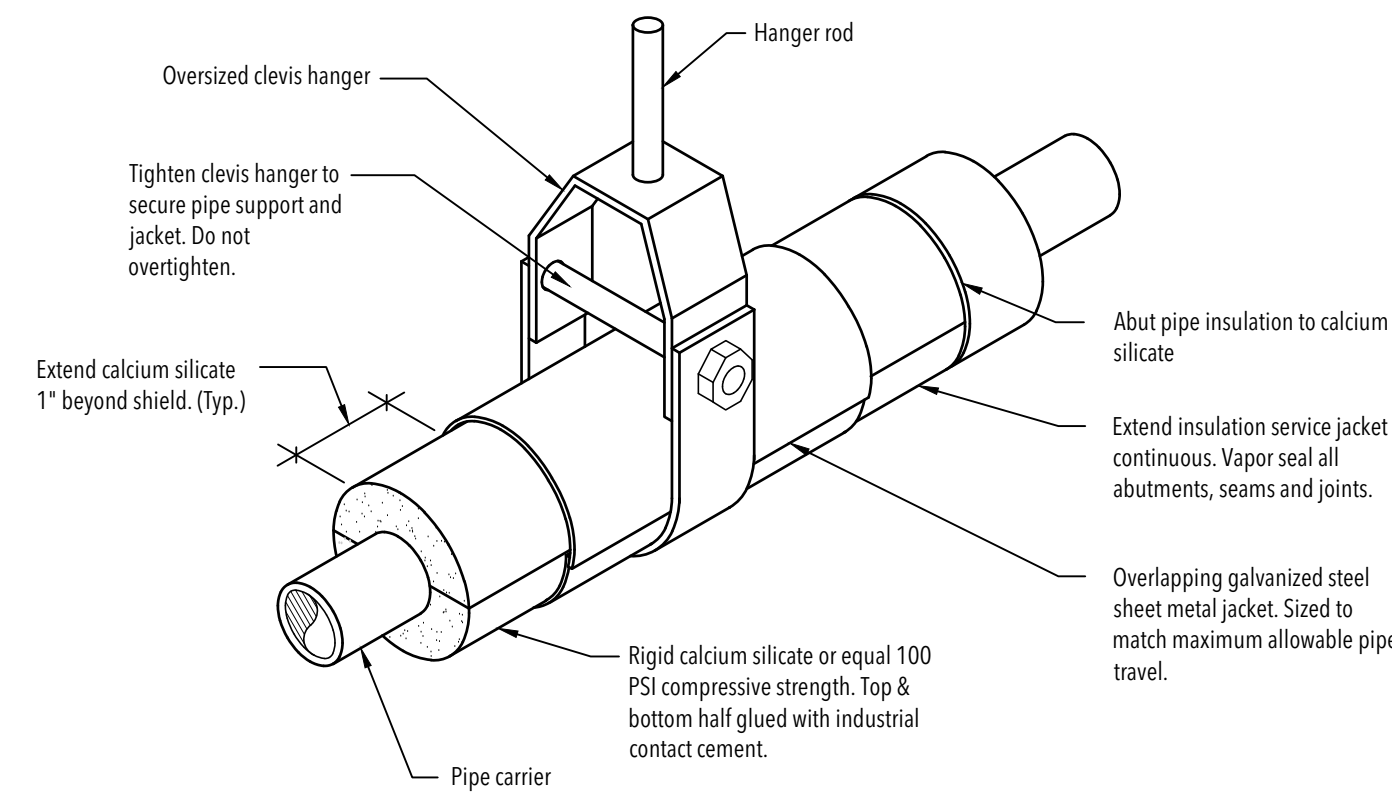

SUSPENDED COPPER DOMESTIC WATER PIPE SUPPORT DETAIL

1 Scale: none

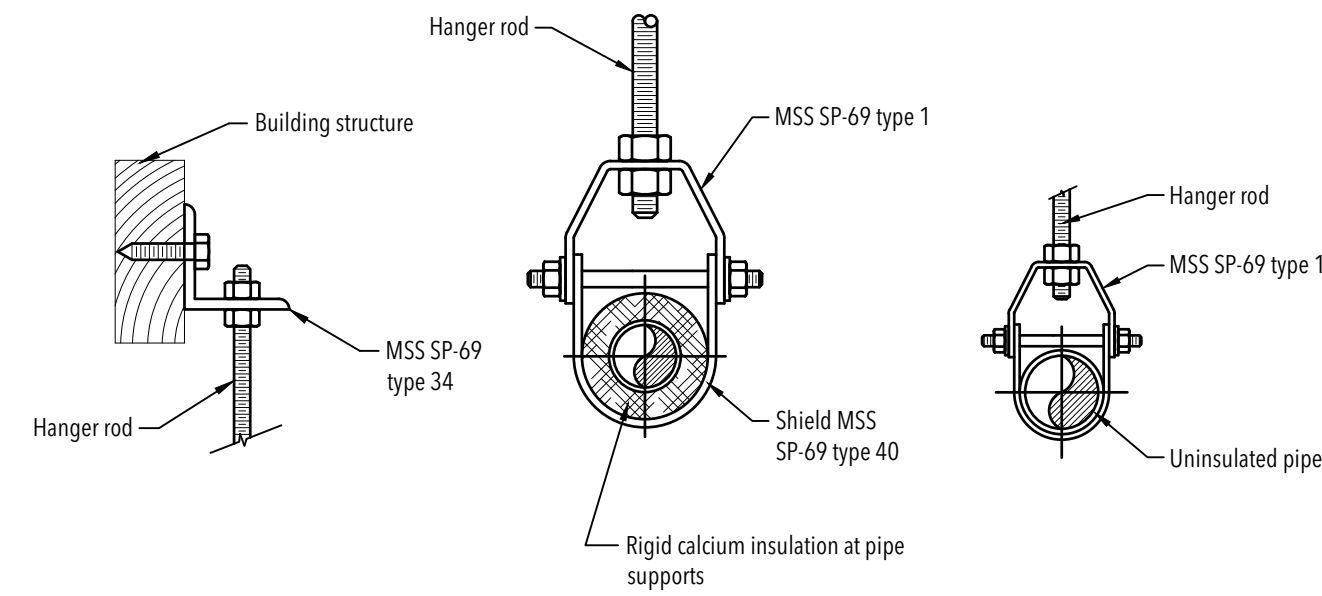

SUSPENDED PIPE SUPPORT DETAIL

2 Scale: none

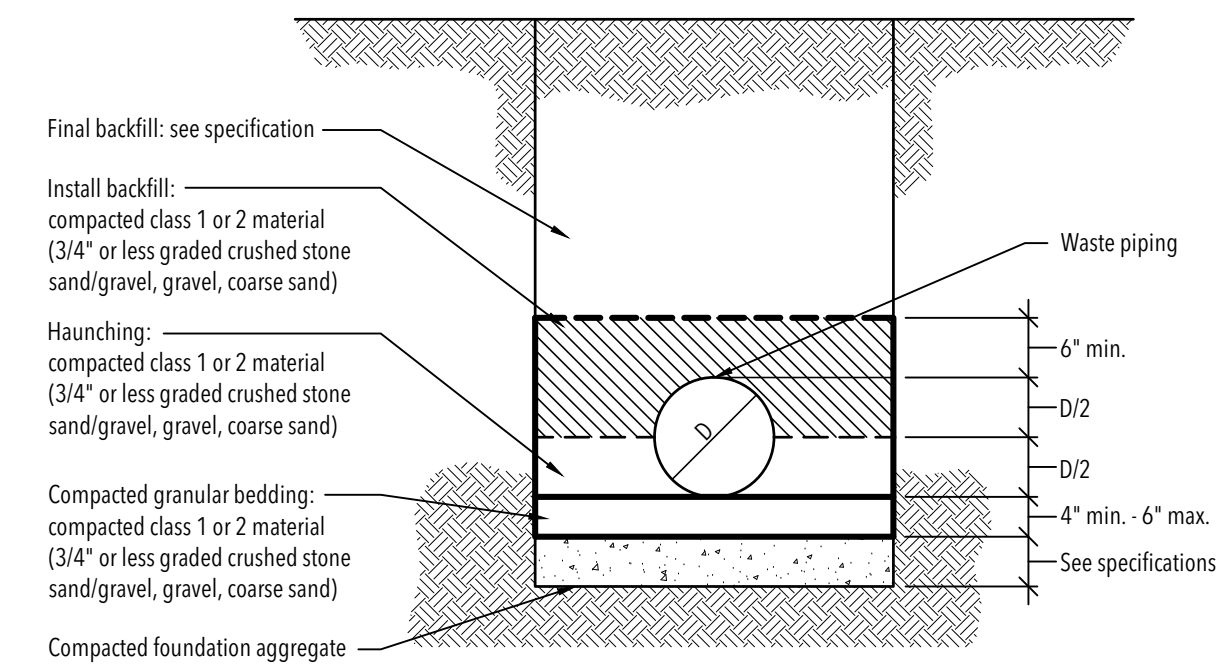

TYPICAL BACKFILL FOR WASTE PIPING

3 Scale: none

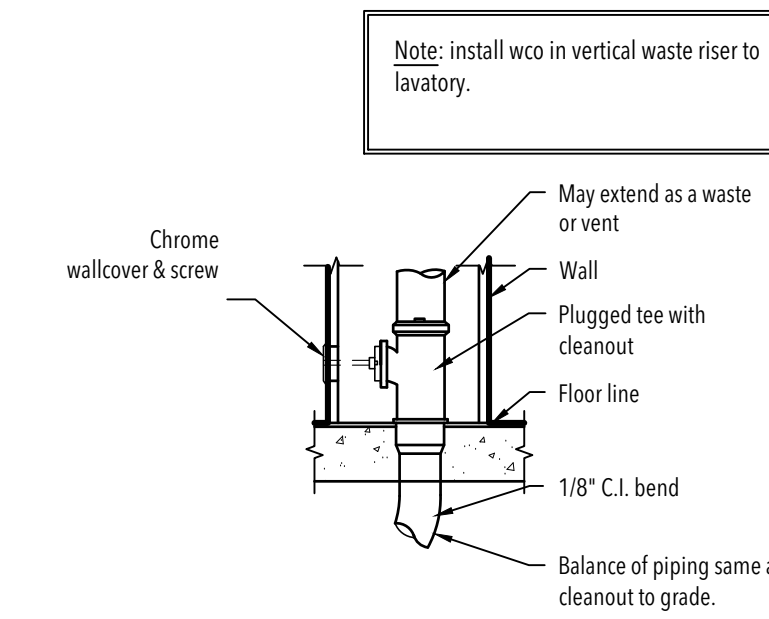

WALL CLEANOUT DETAIL

4 Scale: none

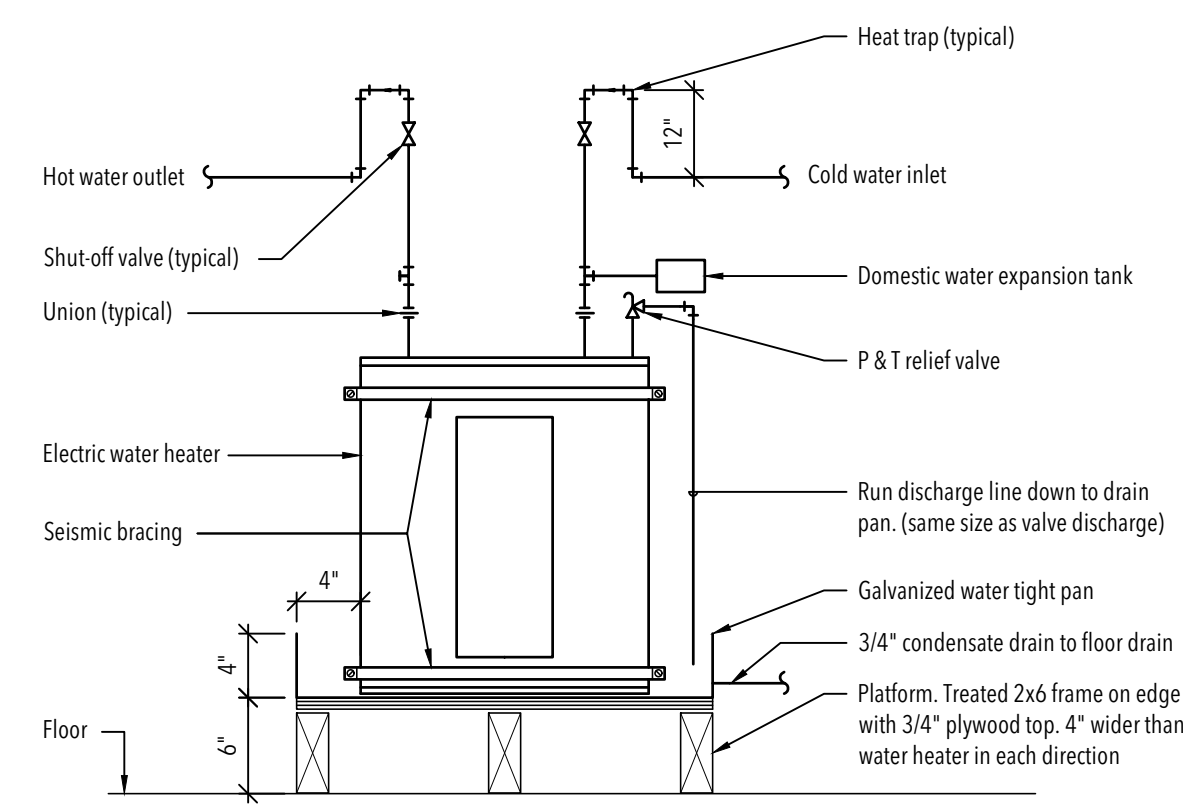

ELECTRIC HOT WATER HEATER DETAIL

5 Scale: none

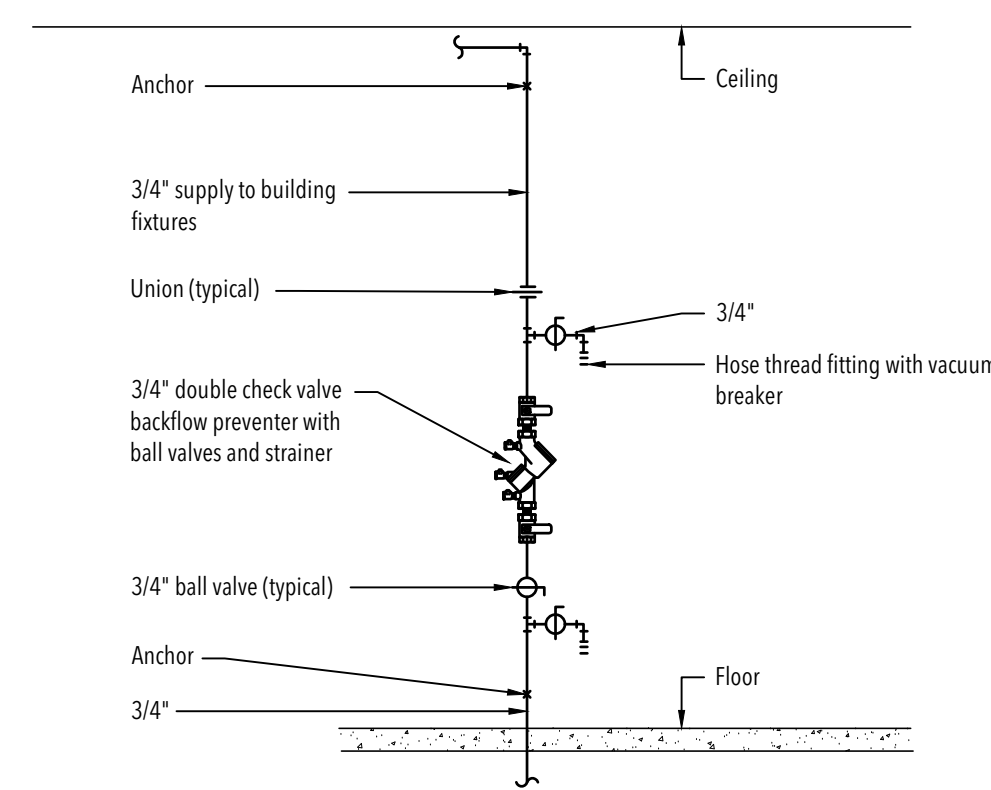

WATER SUPPLY RISER AND BACKFLOW PREVENTER DETAIL

6 Scale: none

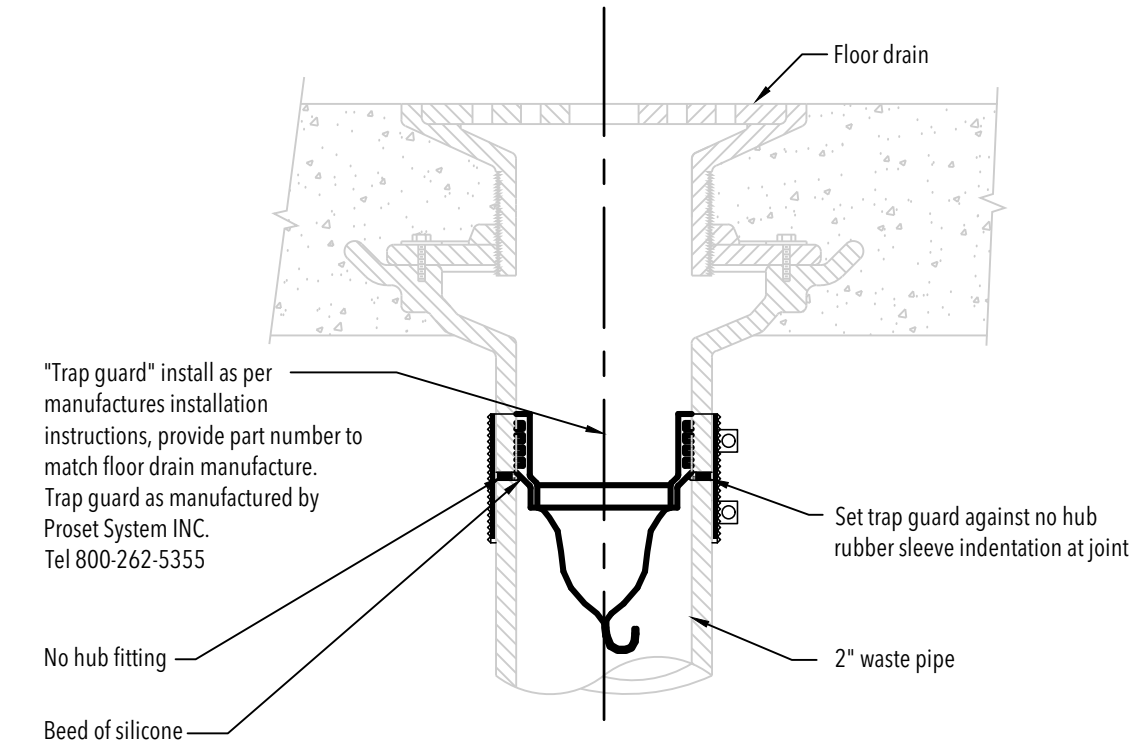

TRAP GUARD TRAP SEAL DETAIL

7 Scale: none

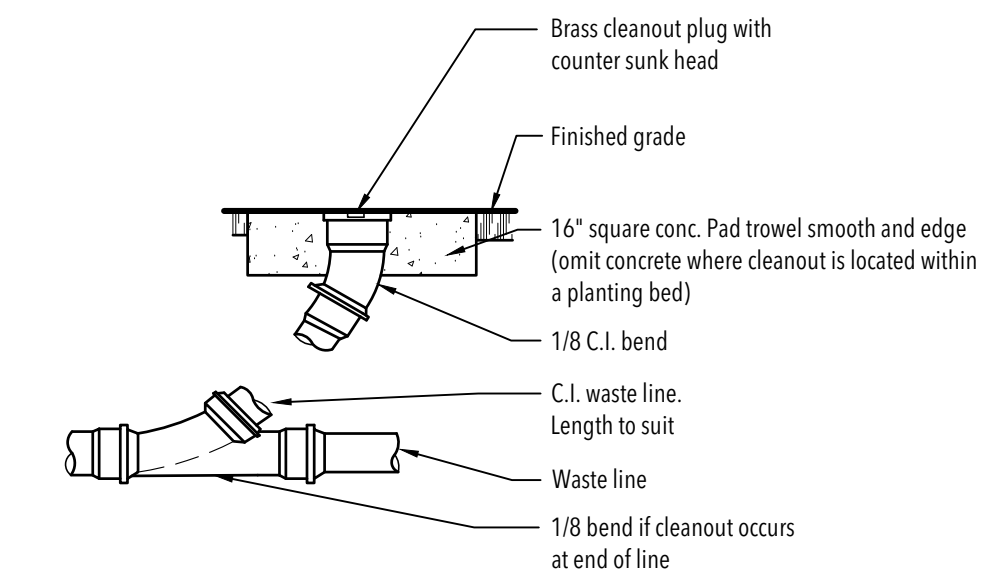

CLEANOUT TO GRADE DETAIL

8 Scale: none

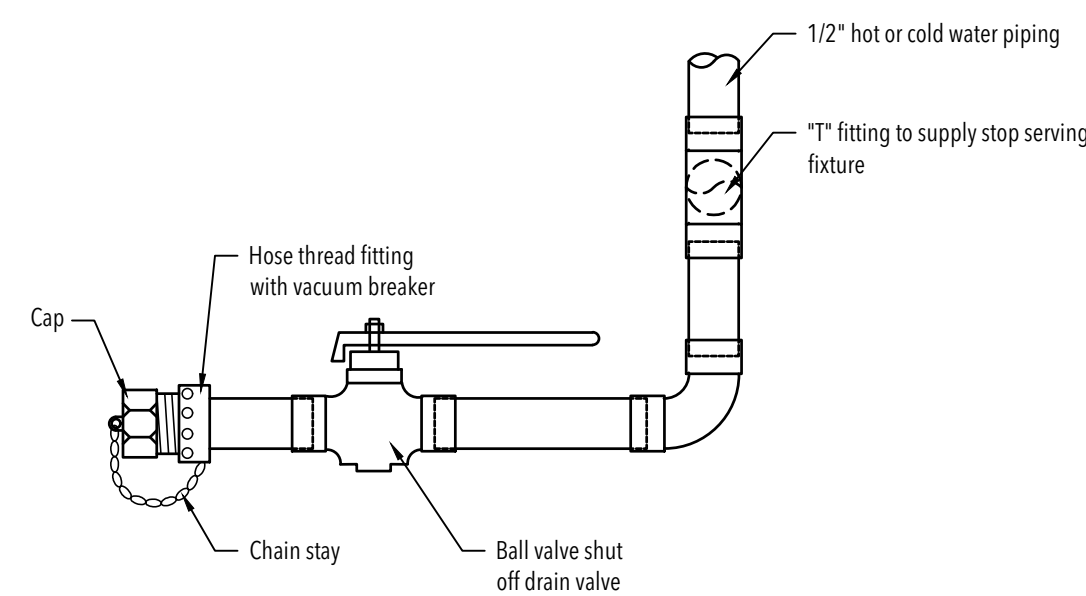

TYPICAL END OF LINE DRAIN VALVE DETAIL

9 Scale: none

NO.	DATE	DESCRIPTION

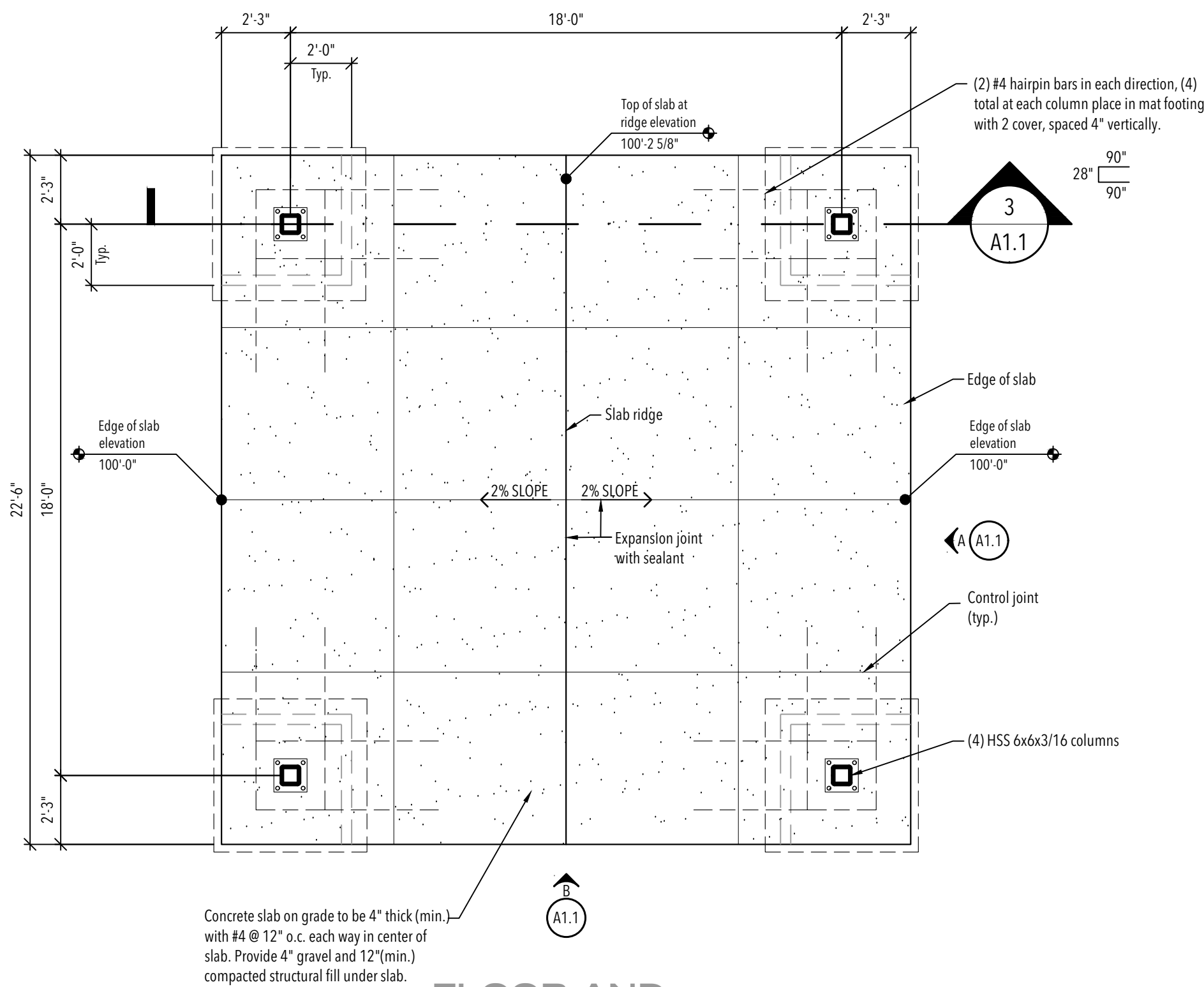

FLOOR AND FOUNDATION PLAN
Scale: 1/4" = 1'-0"

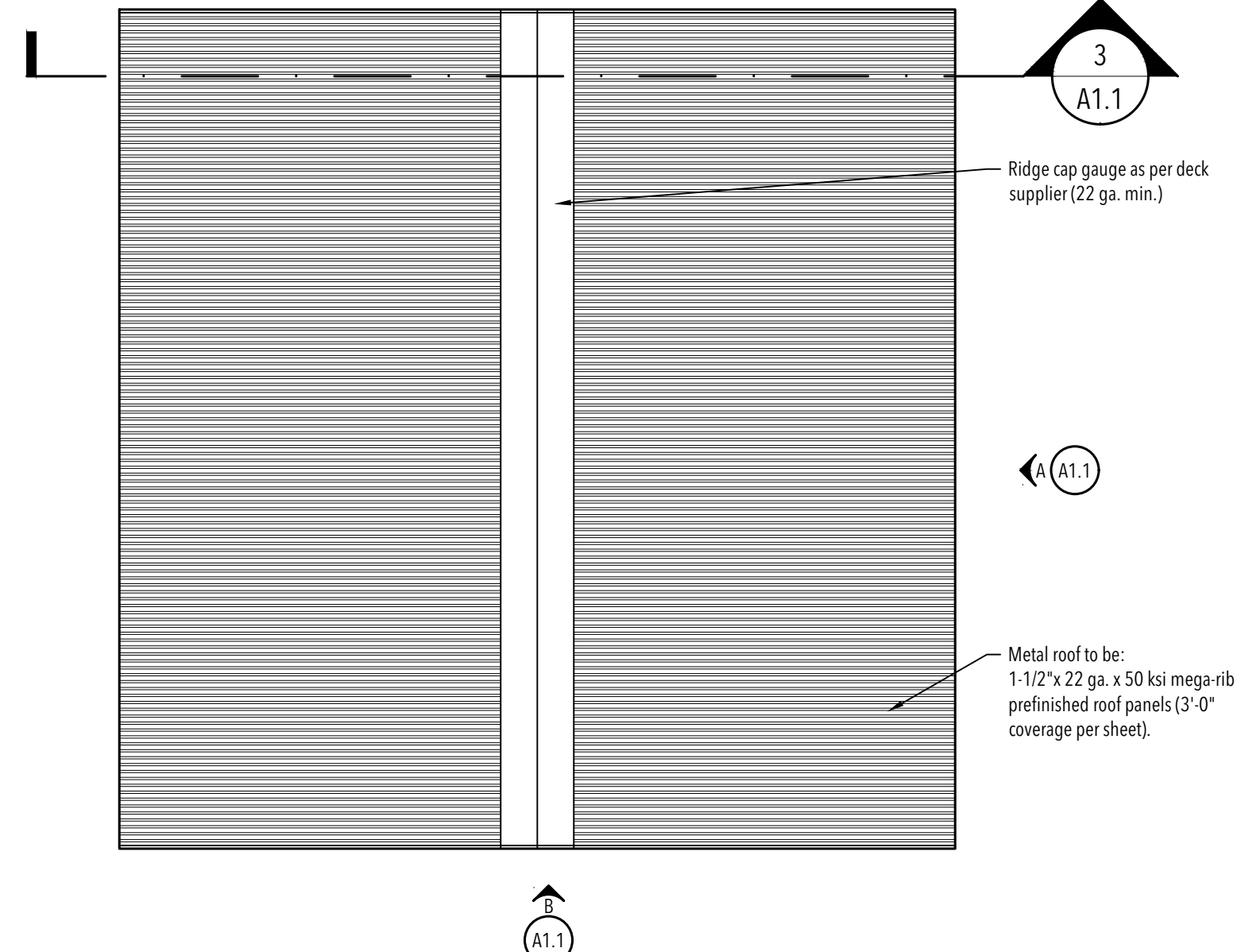

ROOF PLAN
Scale: 1/4" = 1'-0"

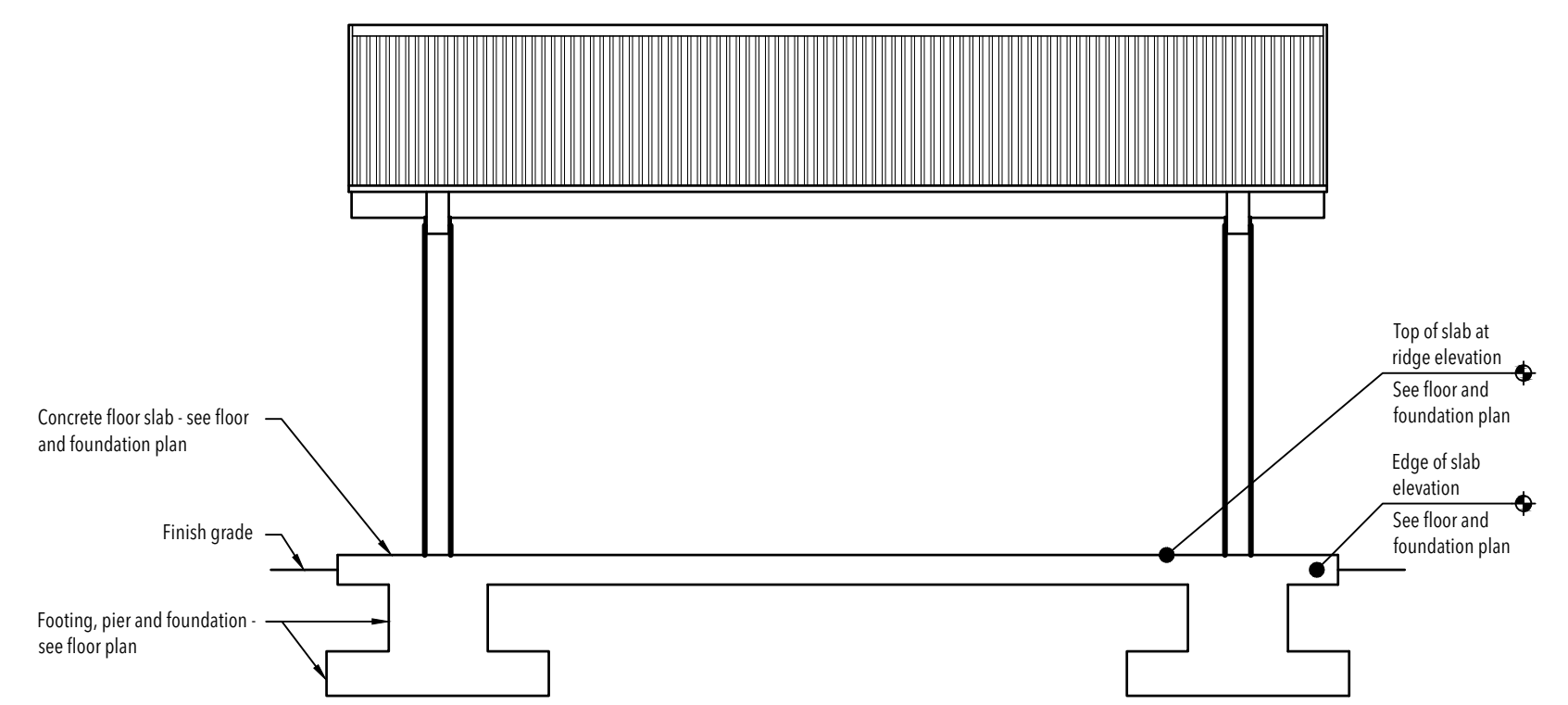

SIDE ELEVATION
Scale: 1/4" = 1'-0"

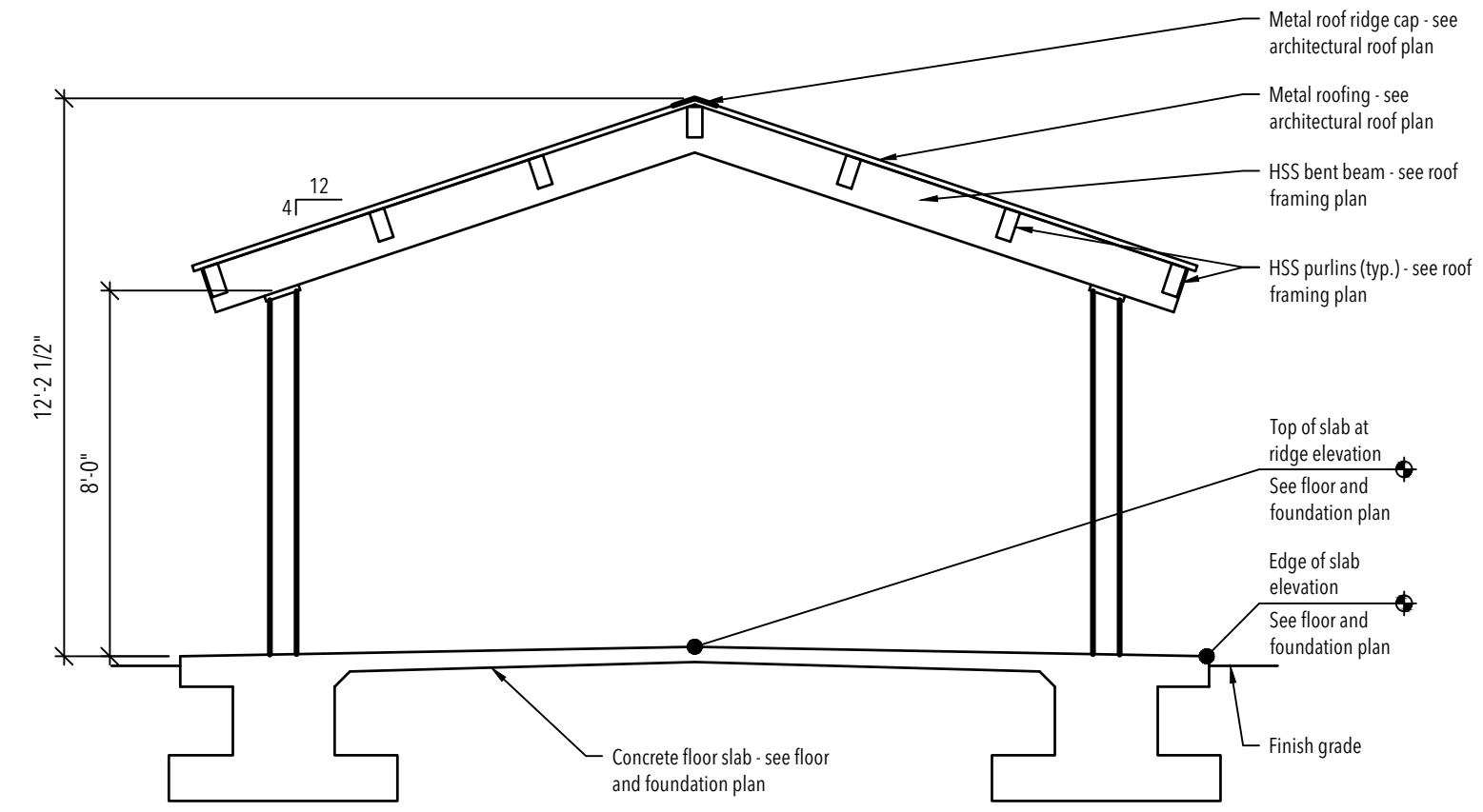

END ELEVATION
Scale: 1/4" = 1'-0"

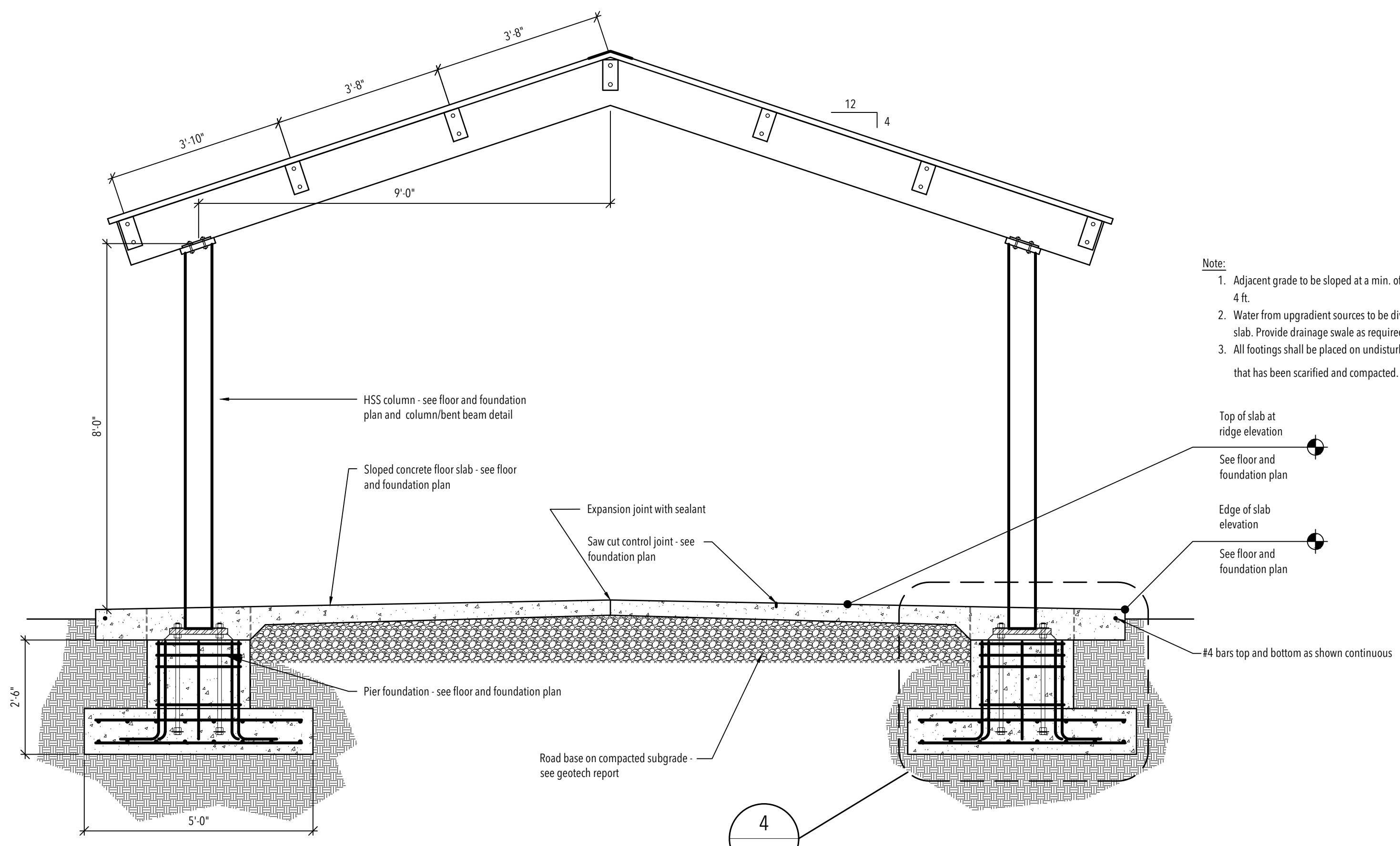

SECTION
Scale: 1/2" = 1'-0"

- Note:**
1. Adjacent grade to be sloped at a min. of 5% from slab for 4 ft.
 2. Water from upgradient sources to be diverted around slab. Provide drainage swale as required.
 3. All footings shall be placed on undisturbed native soil that has been scarified and compacted.

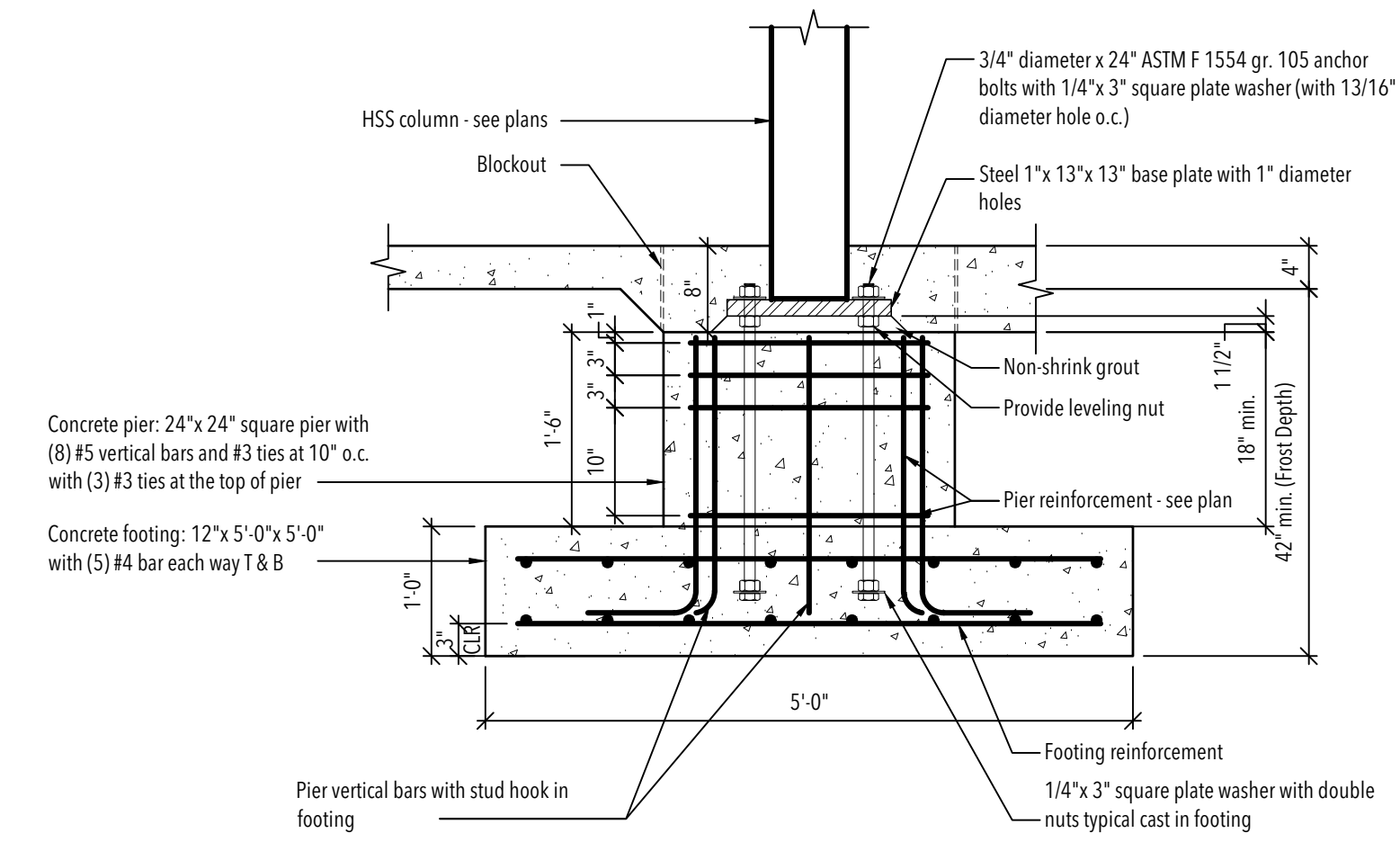

COLUMN, PIER AND FOOTING DETAIL
Scale: 3/4" = 1'-0"

- GENERAL NOTES:**
- Field verify all dimensions and conditions.
 - Twelve (12) dining shelter kits shall be furnished by the Owner and installed by Contractor - re: manufacturer's drawings.
 - Fill beneath pavilion shall be compacted granular imported engineered fill per specification.
 - Contractor is responsible for unloading the dining shelter kits at the site from the flat bed delivery truck. Unloading requires a fork lift.
 - Excess excavated native soil shall not be used beneath the dining shelter slabs but may be used as grading fill elsewhere on site. Slope grade away from the pavilion for 4 feet minimum on all sides and provide compacted granular road base for top 6 inches in this 4 foot perimeter. Any remaining excess native soil may be used as fill elsewhere on the property as directed by the owner.

DINING SHELTER KIT NOTES

- Dining shelters shall be constructed/erected using the dining shelter manufacturer's approved project-specific drawings.
 - Metal components of the dining shelter are factory finished however some touch-up may be necessary.
 - Summary of owner-furnished items:
- The dining shelter kits are to be furnished by the owner from Smith Steel Works. This includes, but is not limited to, the following:
- | Item | Furnished by | Erected/installed by |
|--------------------------|--------------|----------------------|
| Structural steel columns | Owner | Contractor |
| Steel roof beams | Owner | Contractor |
| Mega-Rib metal roofing | Owner | Contractor |
| Anchor bolts | Owner | Contractor |
- Other materials are to be furnished by the contractor. These items include but are not limited to, the following:
- | Item | Furnished by | Erected/installed by |
|---------------------------|--------------|----------------------|
| Concrete work | Contractor | Contractor |
| Steel reinforcing (rebar) | Contractor | Contractor |

NO.	DATE	DESCRIPTION

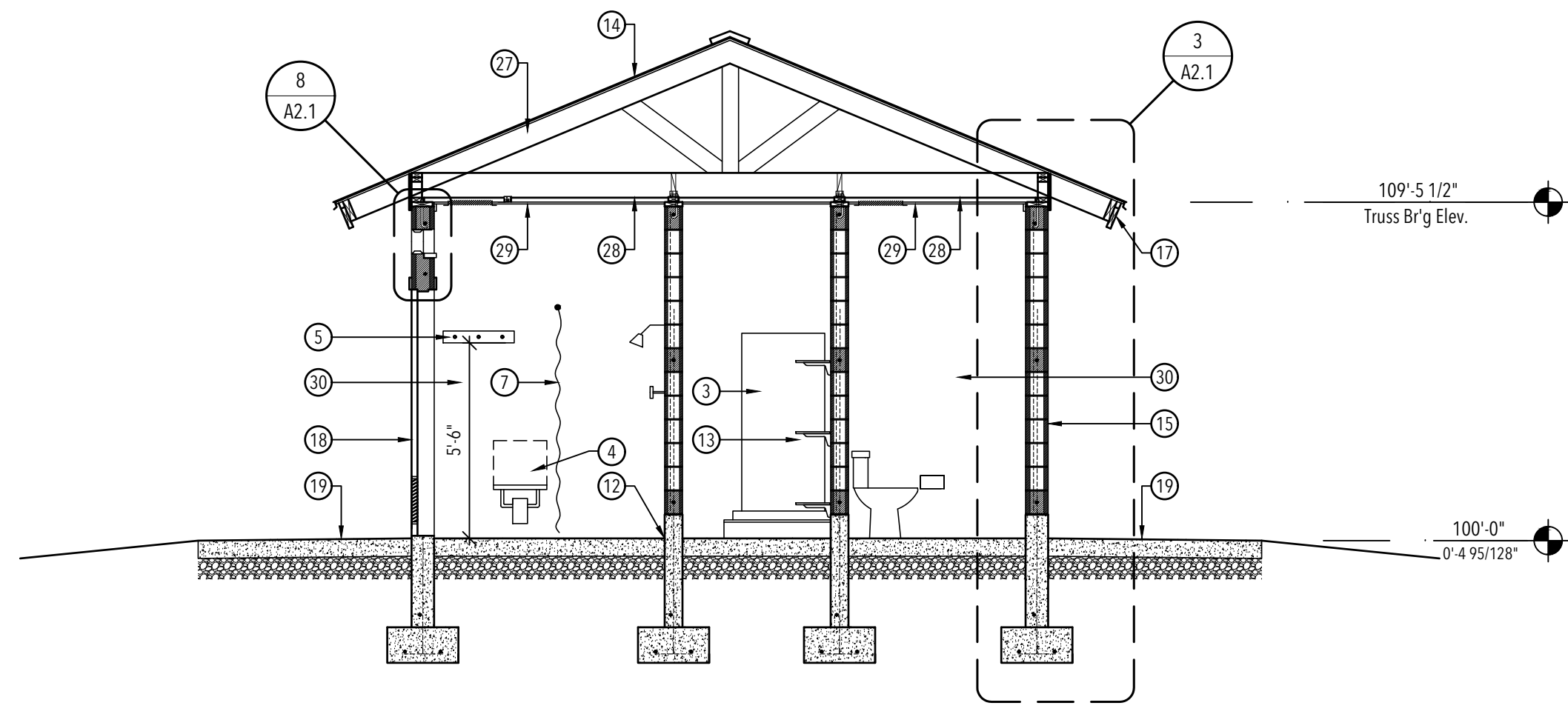

SECTION B
Scale: 1/4" = 1'-0"

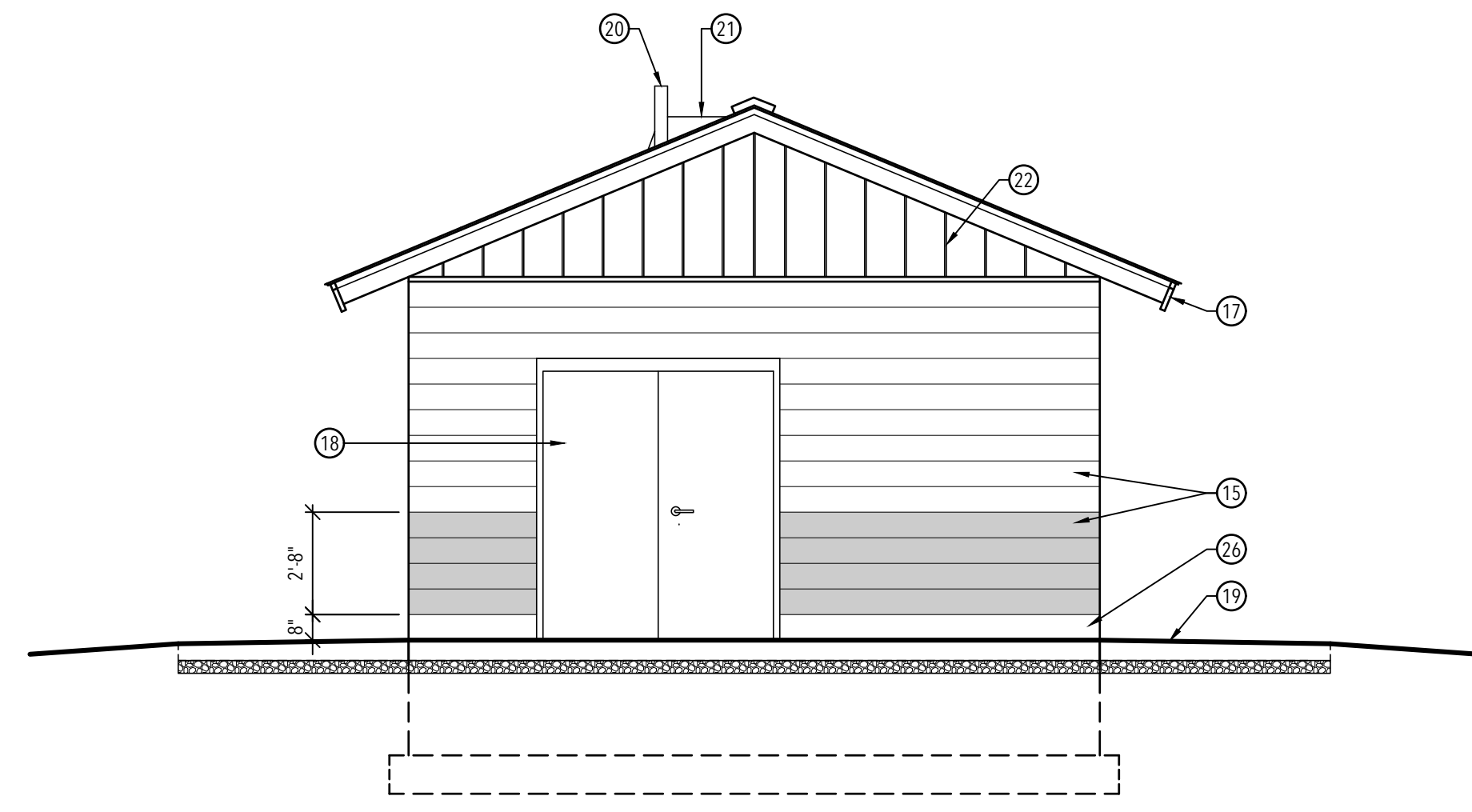

WASH ROOM SIDE ELEVATION C
Scale: 1/4" = 1'-0"

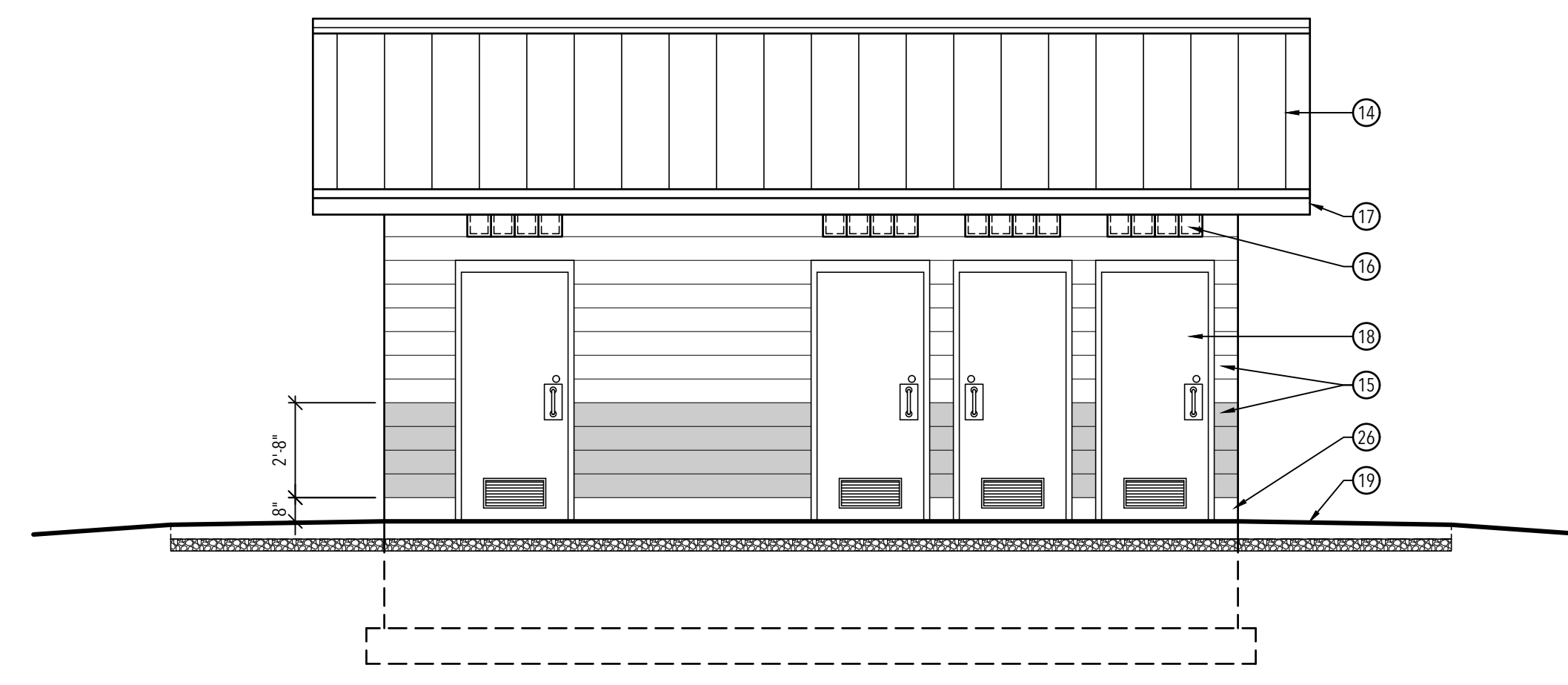

SHOWER SIDE ELEVATION D
Scale: 1/4" = 1'-0"

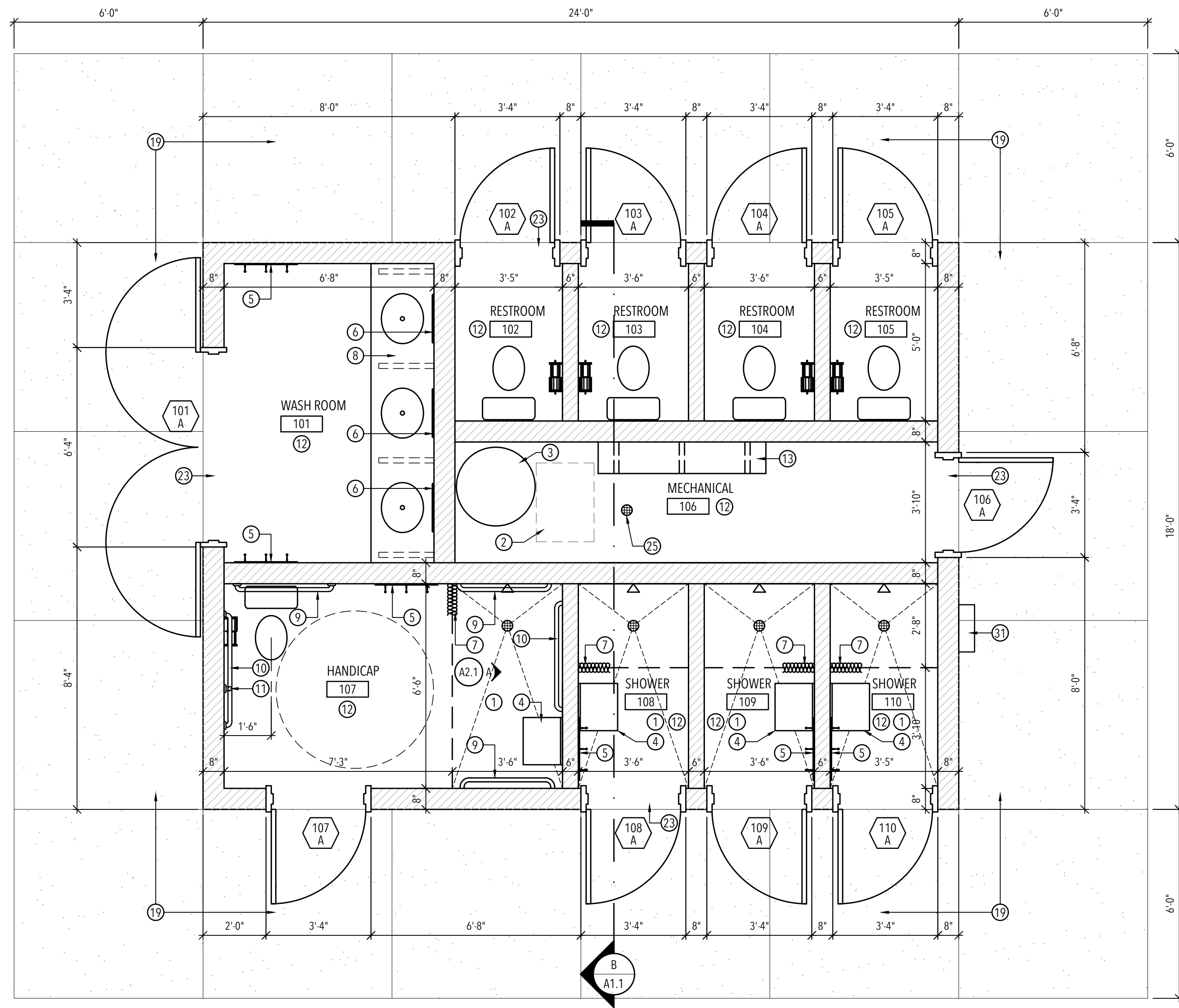

FLOOR PLAN A
Scale: 3/8" = 1'-0"

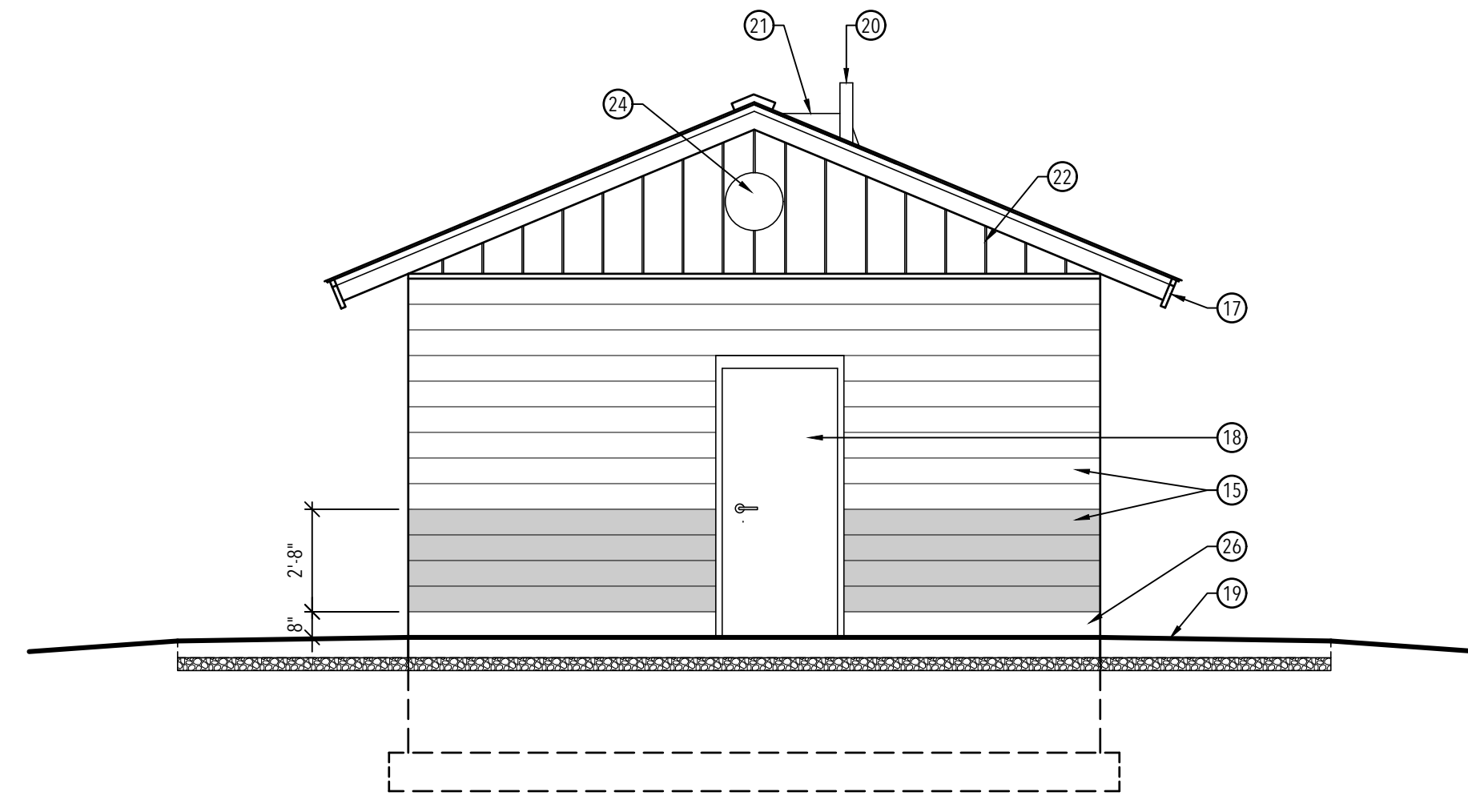

MECHANICAL SIDE ELEVATION E
Scale: 1/4" = 1'-0"

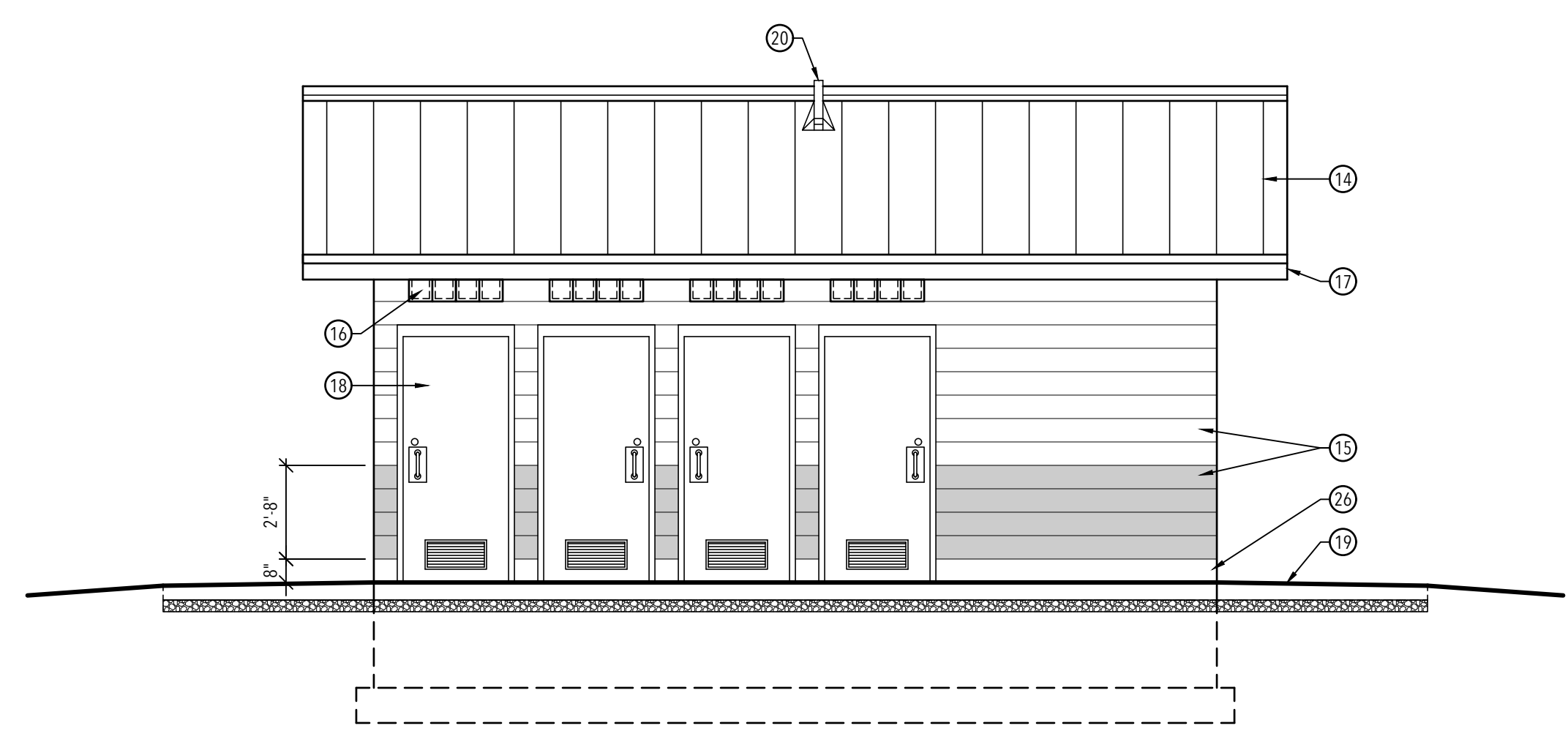

RESTROOM SIDE ELEVATION F
Scale: 1/4" = 1'-0"

- GENERAL NOTES:**
- A. Two restrooms/shower facilities are required for this project. See civil drawings for locations and coordinate with architect for orientation of each facility.
 - B. All interior walls, ceiling, and floors finished with epoxy paint. Exterior walls shall be colored CMU.
 - C. Grab bars to meet local accessibility codes.
 - D. All CMU walls are 8" masonry except where noted otherwise with (1) #4 vert. @32" o.c. (1) #4 horiz. @48" o.c. and ladder type reinforcing at 16" o.c.

- KEYED NOTES:**
1. Slope concrete floor slab to floor drain. Set floor drain 1" lower than perimeter floor elevation.
 2. 22"x30" metal attic access door between trusses. Paint to match ceiling.
 3. Electric water heater.
 4. Folding shower seat re: 5/A2.1.
 5. Stainless steel hookstrip with 3 hooks.
 6. 18"x36" mirror.
 7. Stainless steel shower rod and vinyl curtain.
 8. Stainless steel countertop on steel brackets, re: 7/A2.1.
 9. 36" stainless steel grab bar.
 10. 42" stainless steel grab bar.
 11. 18" stainless steel vertical grab bar.
 12. 3/4" epoxy grout cove at floor/wall in all rooms.
 13. Three 12"x5'-0" adjustable shelves, see 6/A2.1.
 14. 24 Galv. steel standing seam roof, Kynar 500 finish, with high temperature ice and water shield over entire roof.
 15. Colored CMU (2 colors as indicated).
 16. 8" x 8" x 4" glass blocks as shown centered above door re: 8/A2.1.
 17. Pre-finished aluminum fascia.
 18. Paint hollow metal doors and frames, both sides (typical).
 19. 6" thick concrete sidewalk on 4" gravel base. slope 1.5% away from building.
 20. Plumbing vent.
 21. Metal snow cricket.
 22. Pre-finished metal siding over wall sheathing on gable-end truss.
 23. Pour floor slab over foundation at door opening (typical).
 24. Exhaust fan-re: mechanical.
 25. Floor drain-re: plumbing.
 26. Exposed concrete foundation wall.
 27. Engineered roof trusses with 3/4" sheathing.
 28. 5/8" water-resistant gypsum board ceiling with epoxy paint, (typical all rooms).
 29. 1x3 wood ceiling trim with epoxy paint (typical all rooms).
 30. CMU with block filler and epoxy paint (typical at all interior rooms).
 31. Electrical panel-re: electrical.

STUDIO 333 ARCHITECTS
333 24TH STREET
OGDEN, UT 84401
801.394.3033

LICENSED ARCHITECT
NO. AR 984269
Tony K. Pantone
TONY K. PANTONE
STATE OF IDAHO

CAMP HULL VALLEY IMPROVEMENTS
10100 EAST CUB RIVER RD.
PRESTON, IDAHO

NO.	DATE	DESCRIPTION

DATE: 03.15.23
PROJECT NUMBER: 2223
PROPERTY NUMBER: 501-737121050101
SCALE: 1/8" = 1'-0"

FLOOR PLAN,
ELEVATIONS &
BUILDING SECTION
RR/SHOWER
A1.1

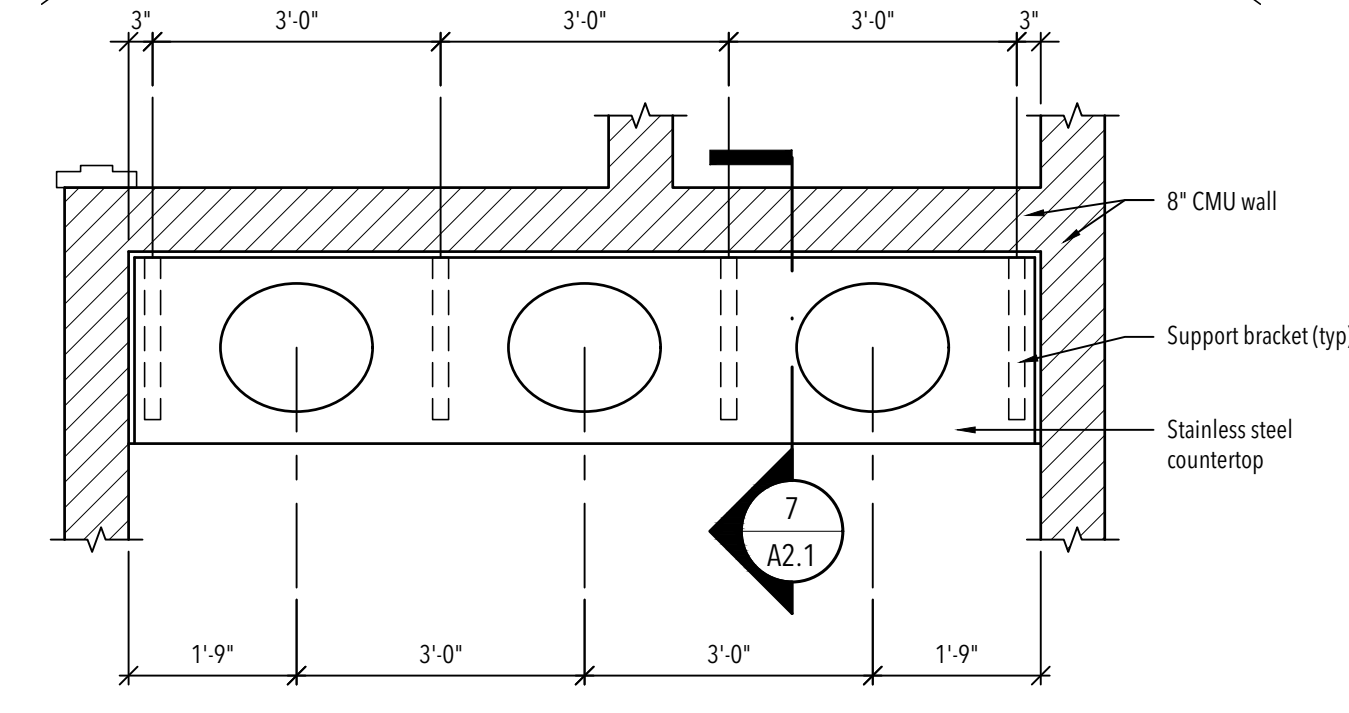
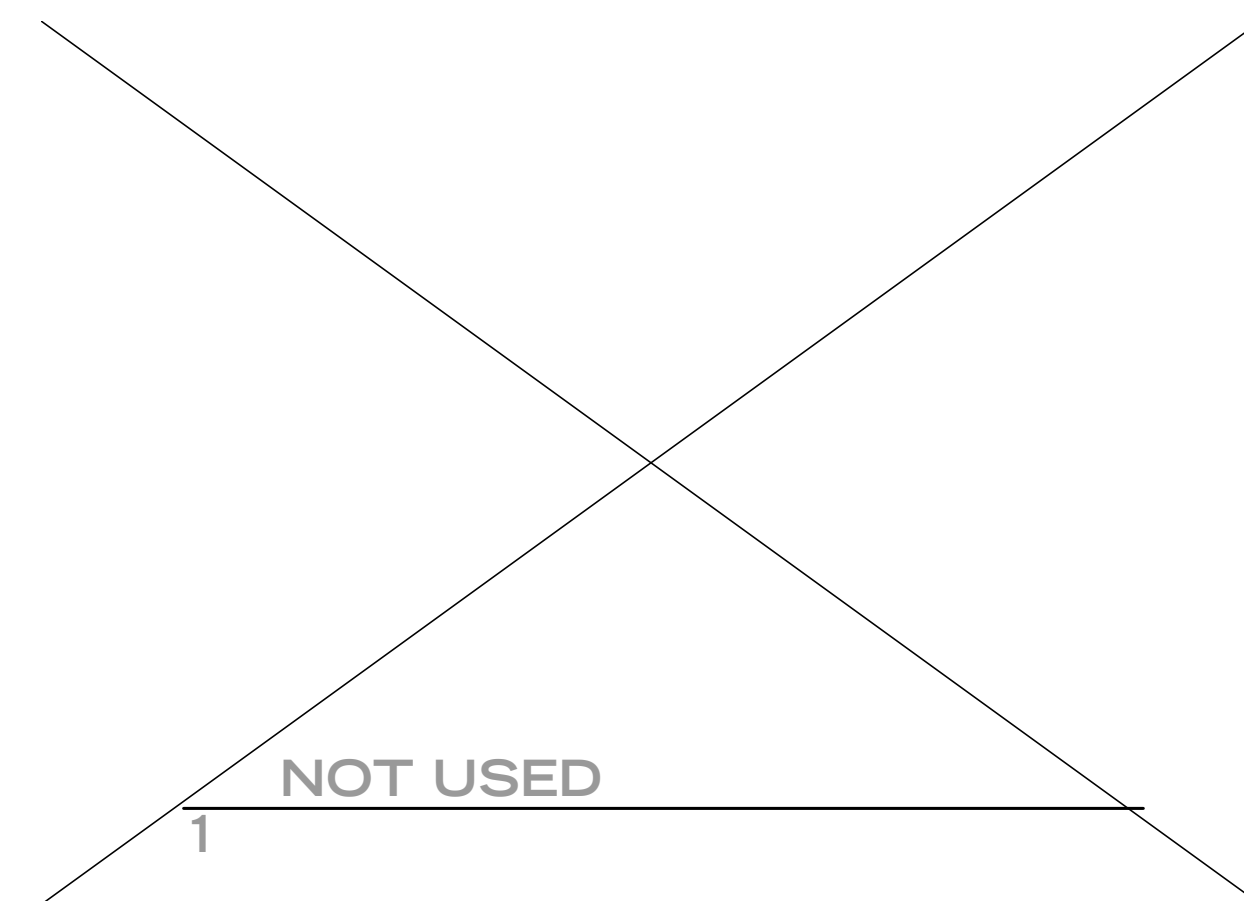

4 VANITY PLAN Scale: 1/2" = 1'-0"

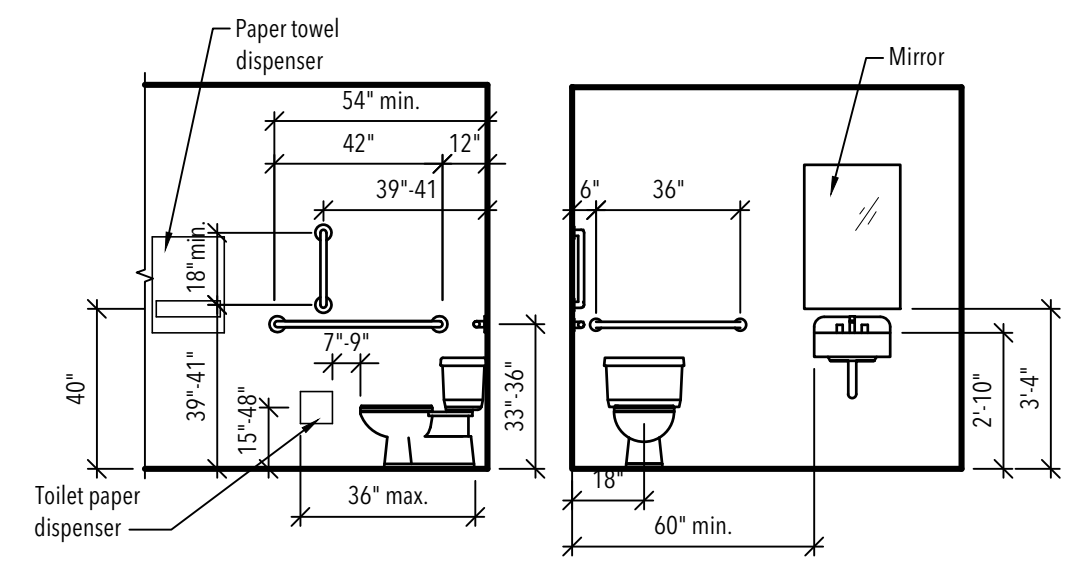

2 TYPICAL ACCESSORY MOUNTING LOCATION Scale: 1/4" = 1'-0"

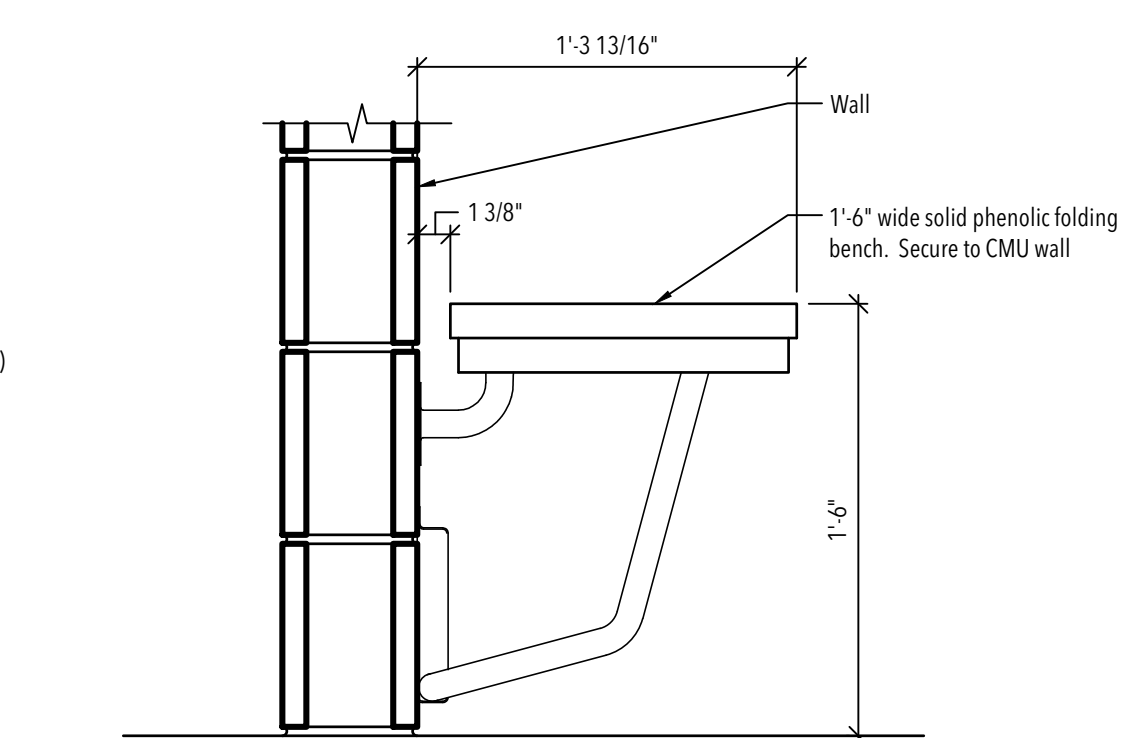

5 BENCH DETAIL Scale: 1 1/2" = 1'-0"

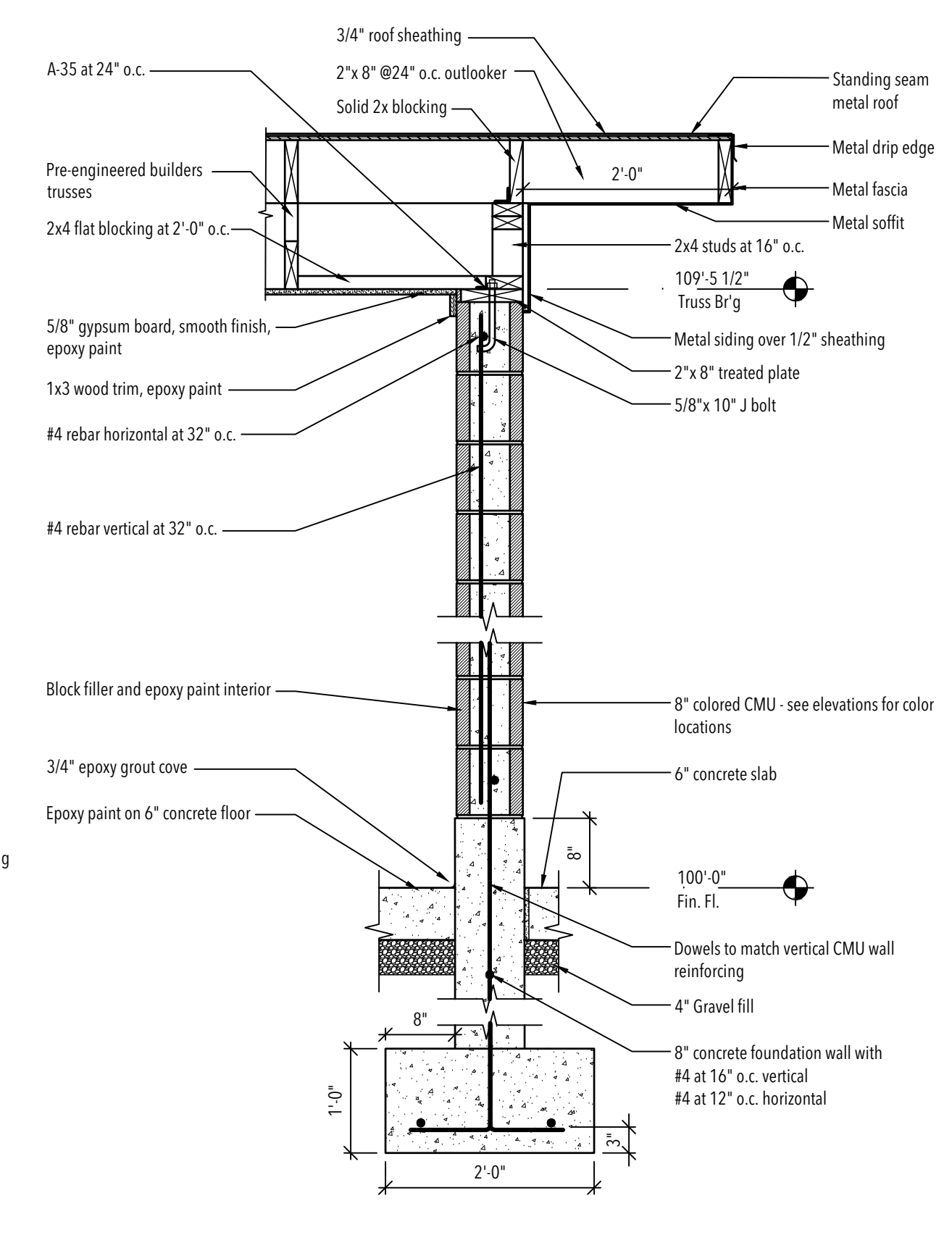

3 WALL SECTION Scale: 3/4" = 1'-0"

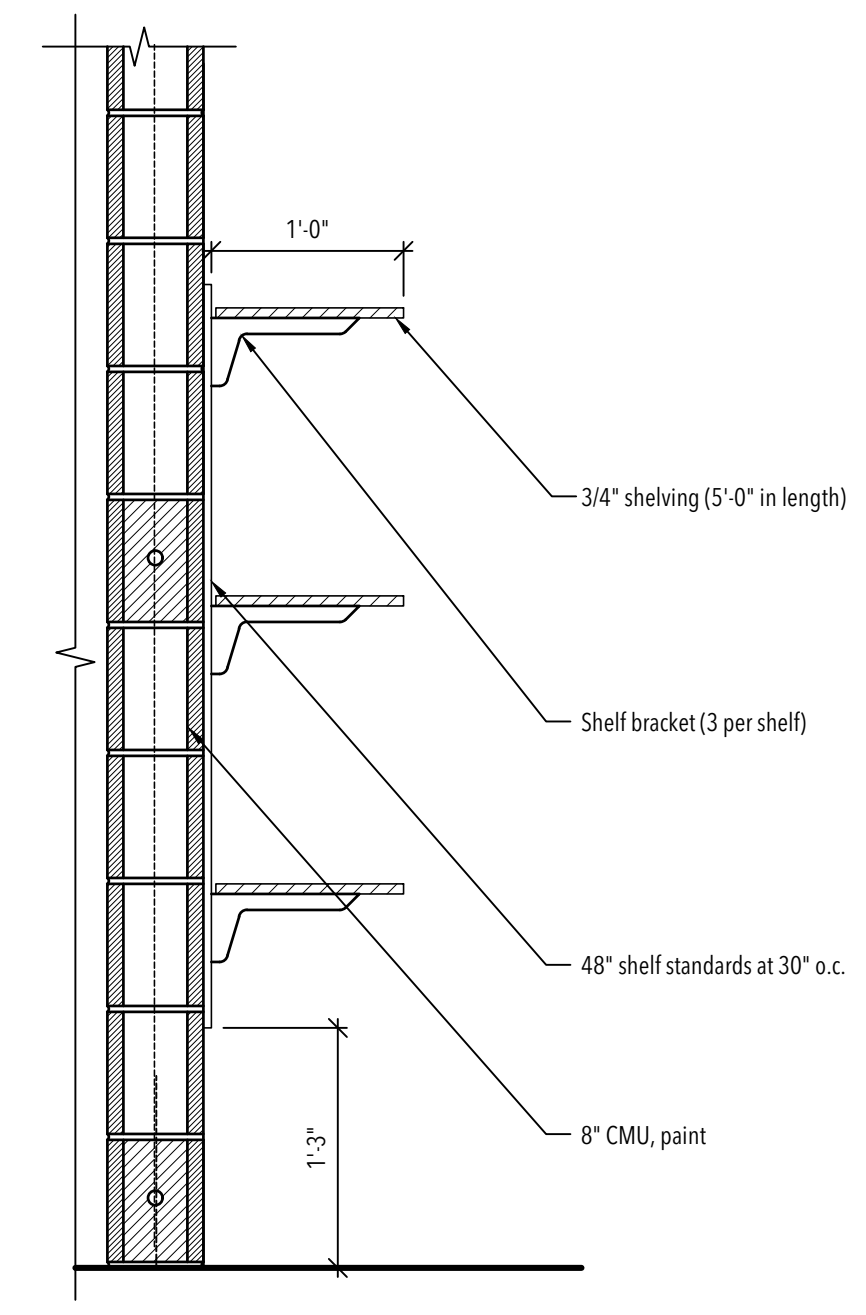

6 SHELF SECTION DETAIL Scale: 1" = 1'-0"

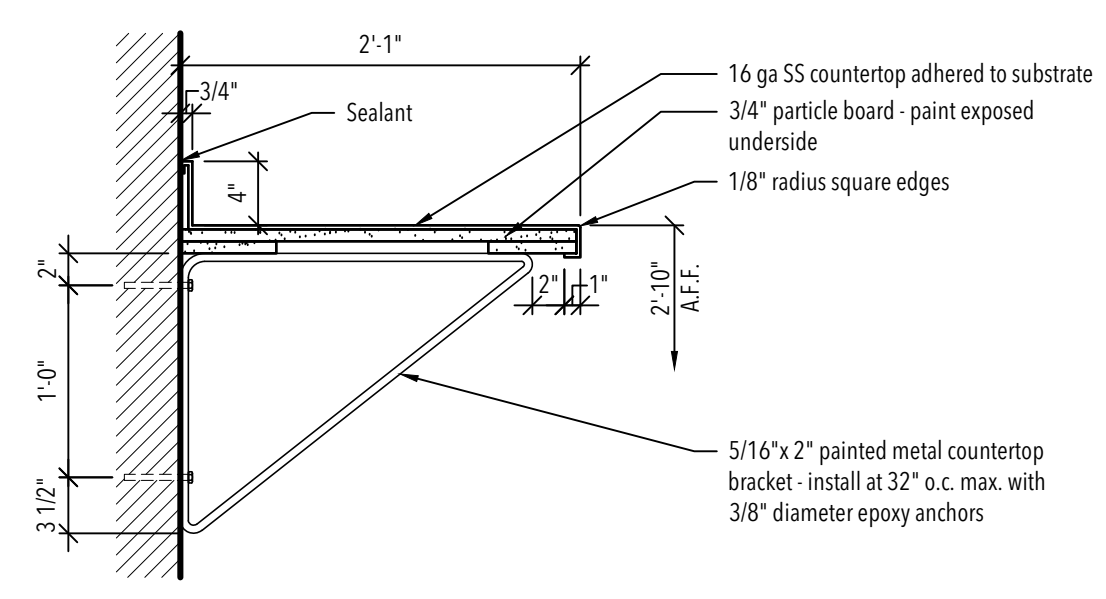

7 COUNTERTOP SECTION Scale: 1" = 1'-0"

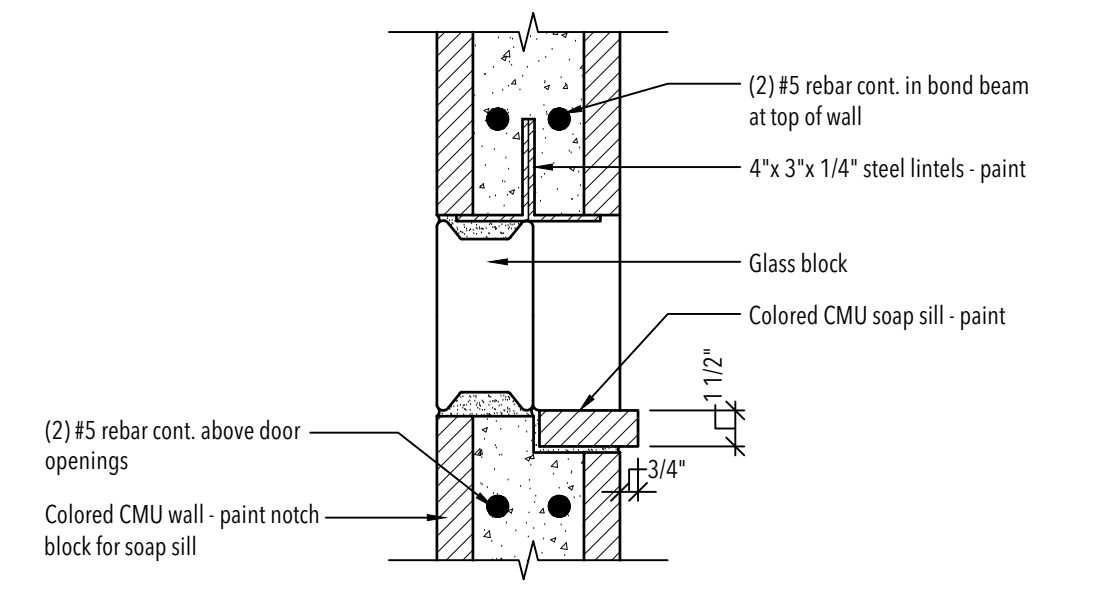

8 GLASS BLOCK DETAIL Scale: 1 1/2" = 1'-0"

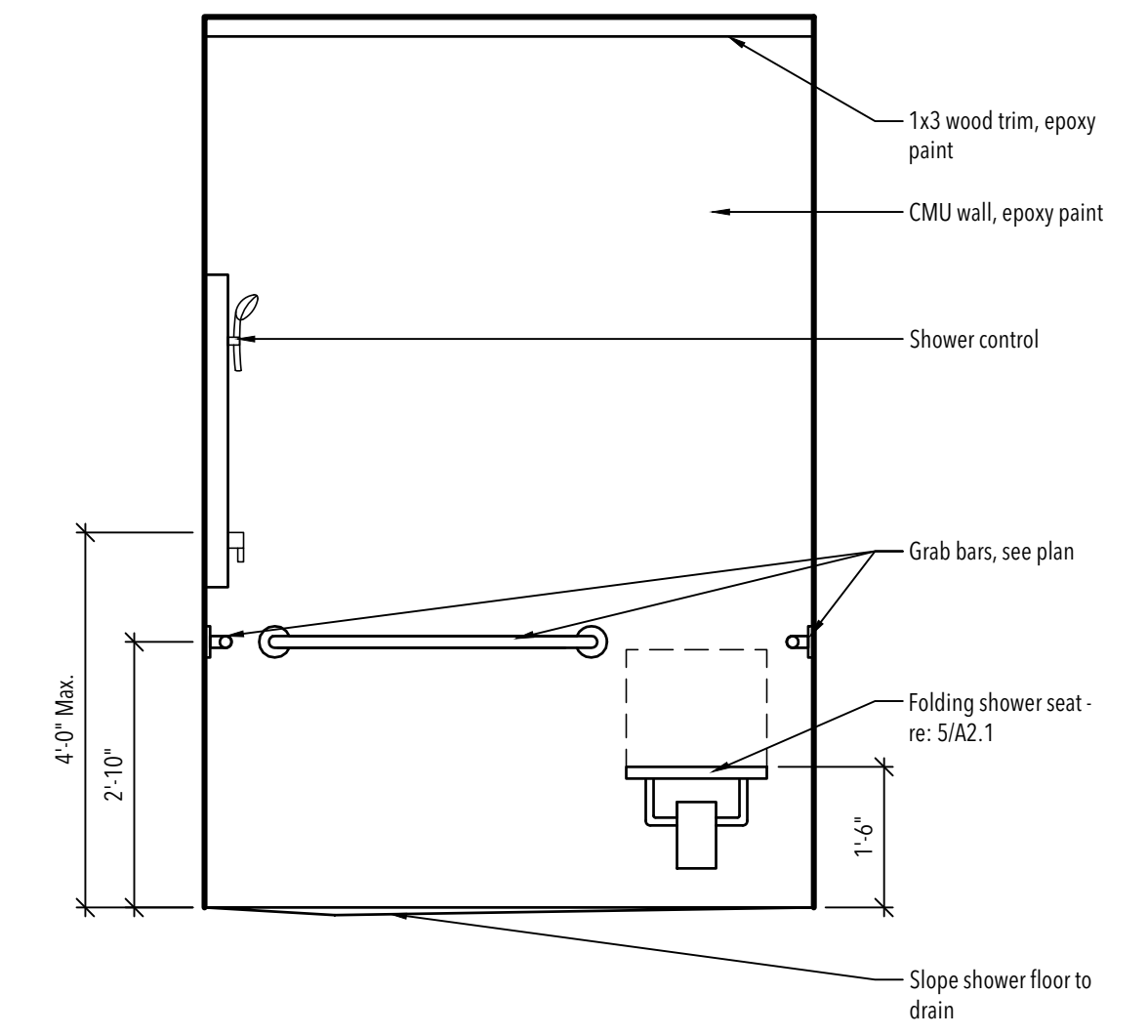

A ACCESSIBLE SHOWER ELEVATION Scale: 1/2" = 1'-0"

NO.	DATE	DESCRIPTION

ROOM FINISH SCHEDULE									
(Information applies to a single building, 2 restroom/shower buildings to be constructed.)									
ROOM NO.	ROOM DESIGNATION	FLOOR	BASE	WALLS	CEILING	CLG. HT.	SPECIALTIES	REMARKS	ROOM NO.
101	Wash room	F1	B1	W1	C1	9'-5"	S2, S3, S7 (2)	--	101
102	Restroom	F1	B1	W1	C1	9'-5"	S2, S3	--	102
103	Restroom	F1	B1	W1	C1	9'-5"	S2, S3	--	103
104	Restroom	F1	B1	W1	C1	9'-5"	S2, S3	--	104
105	Restroom	F1	B1	W1	C1	9'-5"	S2, S3	--	105
106	Mechanical	F1	B1	W1	C1	9'-5"	S1, S2, S6, S9	--	106
107	Handicap	F1	B1	W1	C1	9'-5"	S2, S3, S4, S5, S7, S8	--	107
108	Shower	F1	B1	W1	C1	9'-5"	S2, S3, S5, S7, S8	--	108
109	Shower	F1	B1	W1	C1	9'-5"	S2, S3, S5, S7, S8	--	109
110	Shower	F1	B1	W1	C1	9'-5"	S2, S3, S5, S7, S8	--	110

ROOM FINISH KEY									
(Information applies to a single building, 2 restroom/shower buildings to be constructed.)									
FLOOR		BASE		WALLS		CEILING		SPECIALTIES	
F1	Concrete floor, epoxy paint	B1	3/4" epoxy grout cove	W1	CMU walls, block filler and epoxy paint	C1	5/8" water-resistant gyp. board, smooth finish, epoxy paint	S1	Electric water heater
								S2	1x3 wood ceiling trim, epoxy paint.
								S3	Hollow metal door and frame, paint.
								S4	Grab bars, see plan.
								S5	Folding seat, see 5/A2.1
								S6	Attic access door
								S7	Stainless steel hook strip
								S8	Shower curtain and rod
								S9	Adjustable shelves, see 6/A2.1

DOOR SCHEDULE																				
(Information applies to a single building, 2 restroom/shower buildings to be constructed.)																				
NO.	ROOM NAME	DOOR							FIRE RATING (MIN)	FRAME				DETAILS			HDWR. GROUP	REMARKS	NO.	
		WIDTH	HEIGHT	THICK.	TYPE	CONST.	FINISH	GLASS		WIDTH	TYPE	CONST.	SIDELITE	TRANSOM	HEAD	JAMB				THRESH.
101A	WASH ROOM	3'-0" pr.	7'-0"	1-3/4"	A	metal	paint	--	--	8-3/4"	1	h.m.	--	--	1/A3.1	2/A3.1	--	RR/S10	Galv. door & frame	101A
102A	RESTROOM	3'-0"	7'-0"	1-3/4"	A	metal	paint	--	--	8-3/4"	1	h.m.	--	--	1/A3.1	2/A3.1	--	RR/S1	Galv. door & frame	102A
103A	RESTROOM	3'-0"	7'-0"	1-3/4"	A	metal	paint	--	--	8-3/4"	1	h.m.	--	--	1/A3.1	2/A3.1	--	RR/S1	Galv. door & frame	103A
104A	RESTROOM	3'-0"	7'-0"	1-3/4"	A	metal	paint	--	--	8-3/4"	1	h.m.	--	--	1/A3.1	2/A3.1	--	RR/S1	Galv. door & frame	104A
105A	RESTROOM	3'-0"	7'-0"	1-3/4"	A	metal	paint	--	--	8-3/4"	1	h.m.	--	--	1/A3.1	2/A3.1	--	RR/S1	Galv. door & frame	105A
106A	MECHANICAL	3'-0"	7'-0"	1-3/4"	A	metal	paint	--	--	8-3/4"	1	h.m.	--	--	1/A3.1	2/A3.1	--	RR/S2	Galv. door & frame	106A
107A	HANDICAP	3'-0"	7'-0"	1-3/4"	A	metal	paint	--	--	8-3/4"	1	h.m.	--	--	1/A3.1	2/A3.1	--	RR/S1	Galv. door & frame	107A
108A	SHOWER	3'-0"	7'-0"	1-3/4"	A	metal	paint	--	--	8-3/4"	1	h.m.	--	--	1/A3.1	2/A3.1	--	RR/S1	Galv. door & frame	108A
109A	SHOWER	3'-0"	7'-0"	1-3/4"	A	metal	paint	--	--	8-3/4"	1	h.m.	--	--	1/A3.1	2/A3.1	--	RR/S1	Galv. door & frame	109A
110A	SHOWER	3'-0"	7'-0"	1-3/4"	A	metal	paint	--	--	8-3/4"	1	h.m.	--	--	1/A3.1	2/A3.1	--	RR/S1	Galv. door & frame	110A

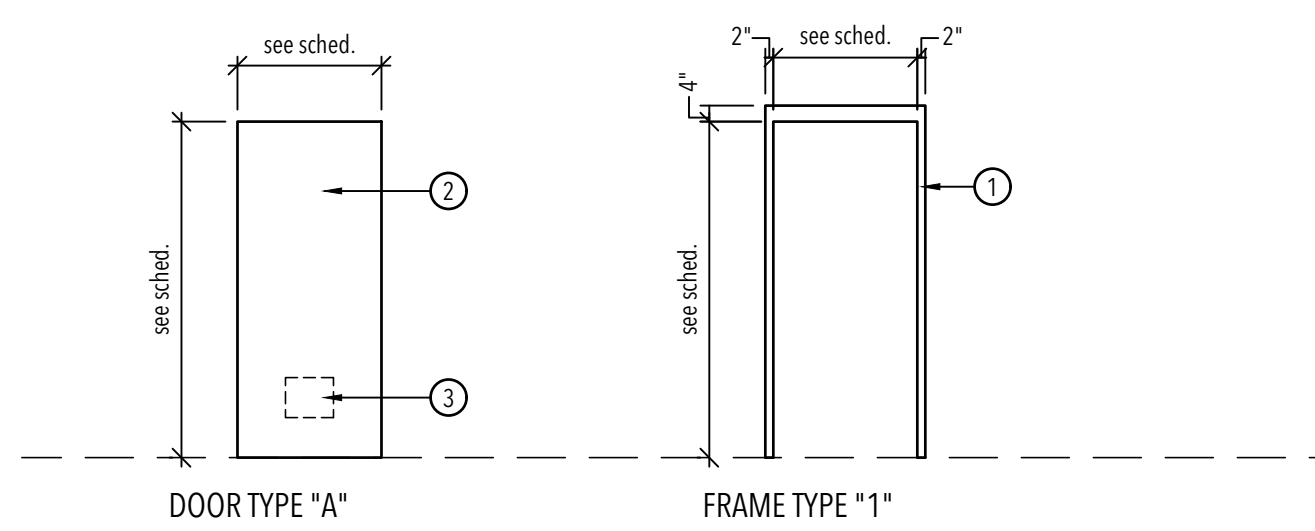

- KEYED NOTES:**
- Hollow metal frame, paint.
 - Metal door, paint.
 - Door grille where occurs, see door schedule and sheet M1.1

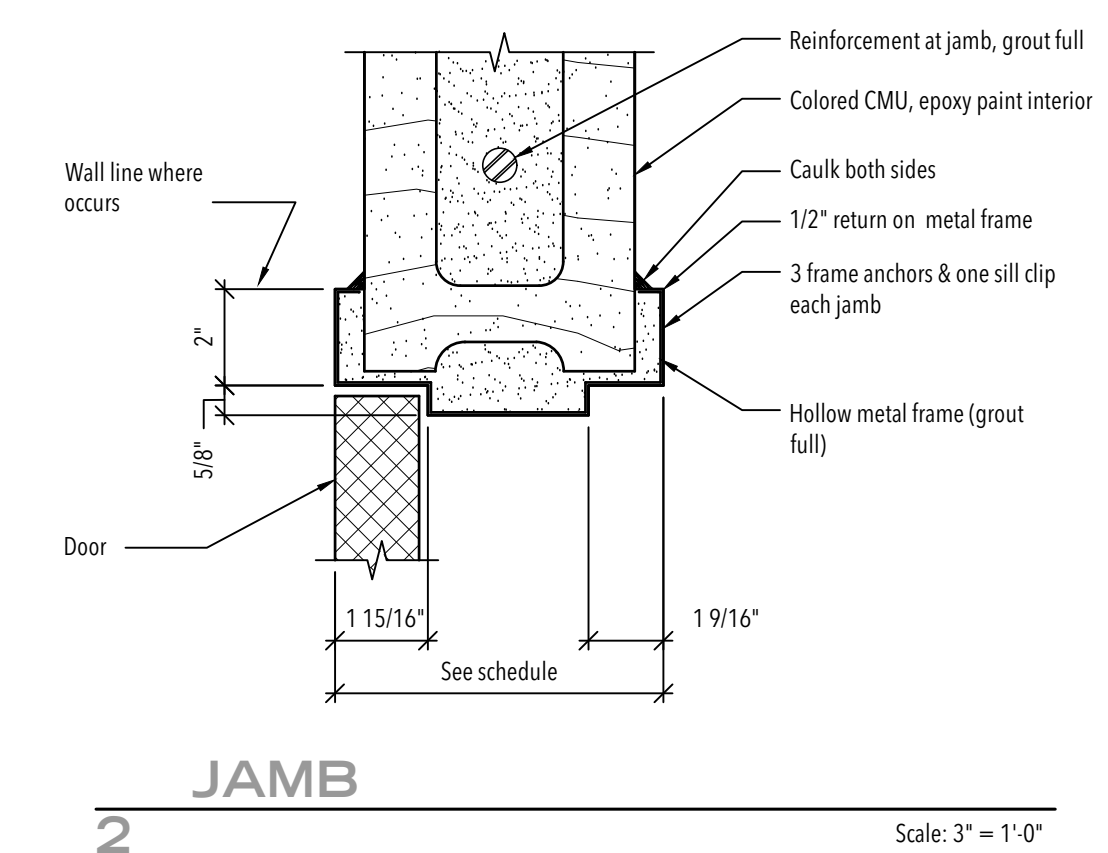
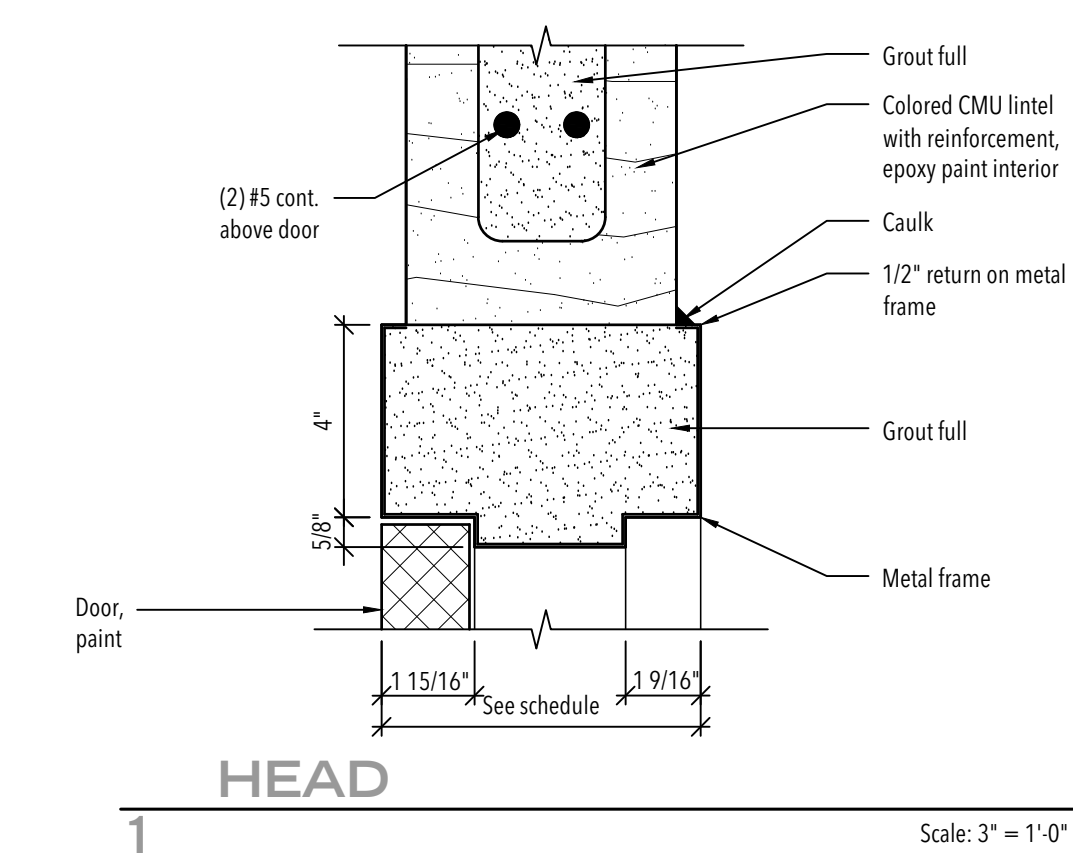

NO.	DATE	DESCRIPTION

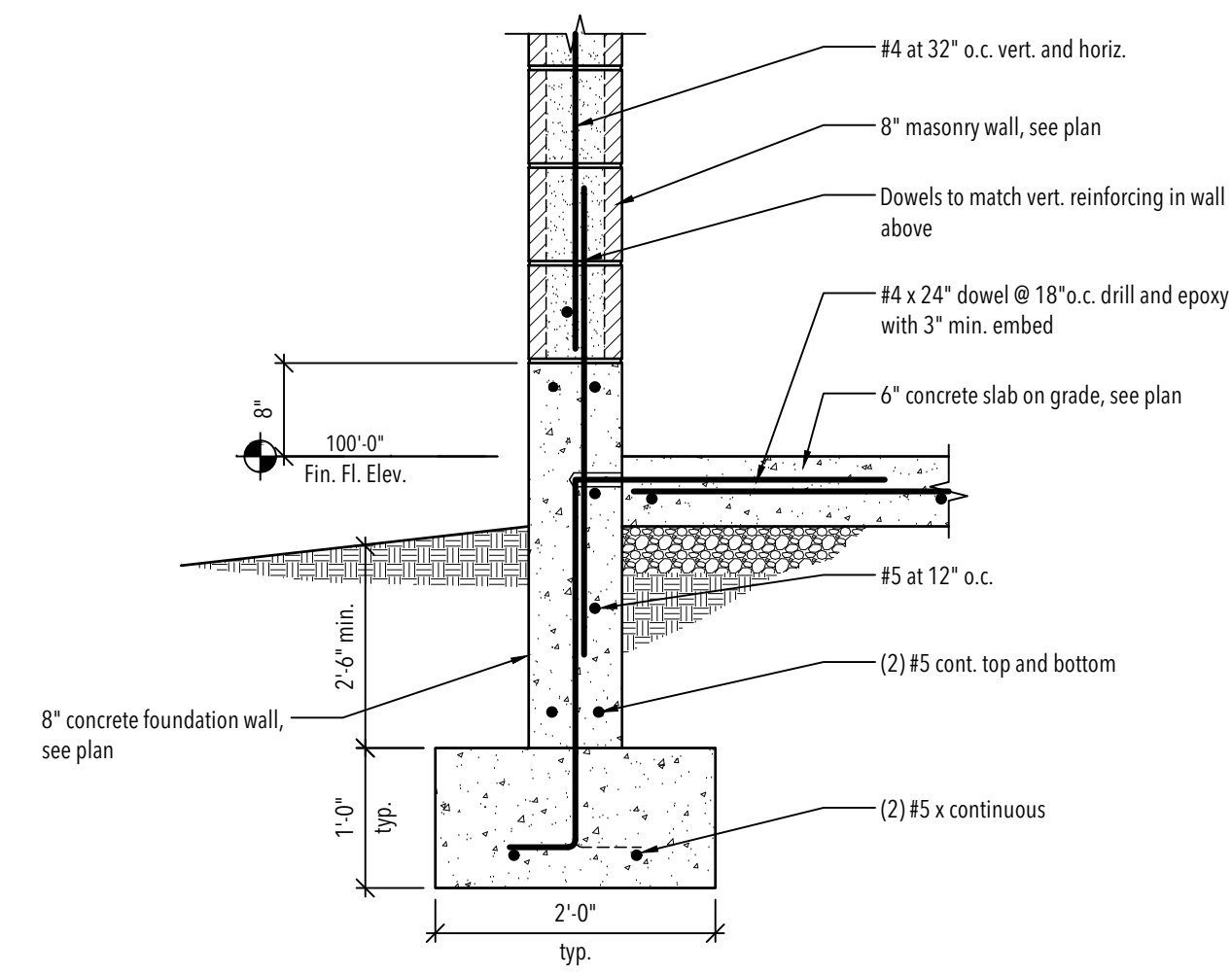

TYPICAL EXTERIOR FOOTING

1 Scale: 3/4" = 1'-0"

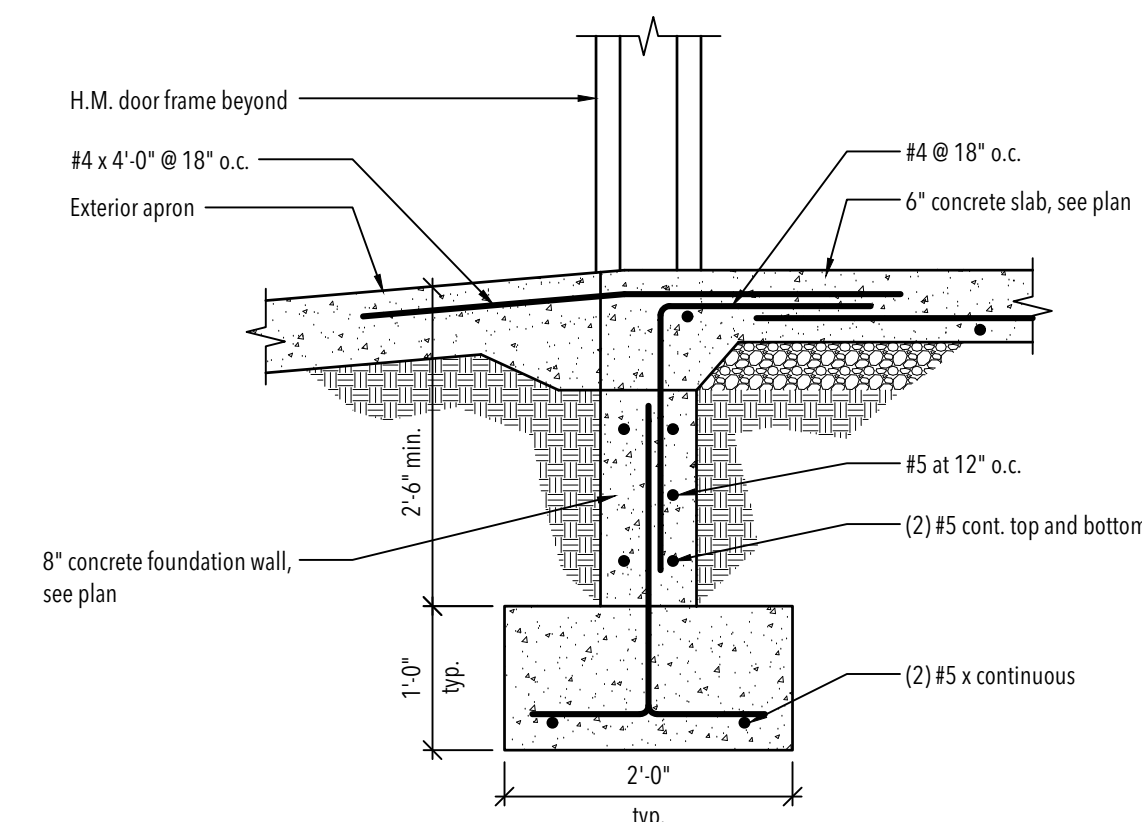

FLOOR SLAB AT DOOR OPENING

2 Scale: 3/4" = 1'-0"

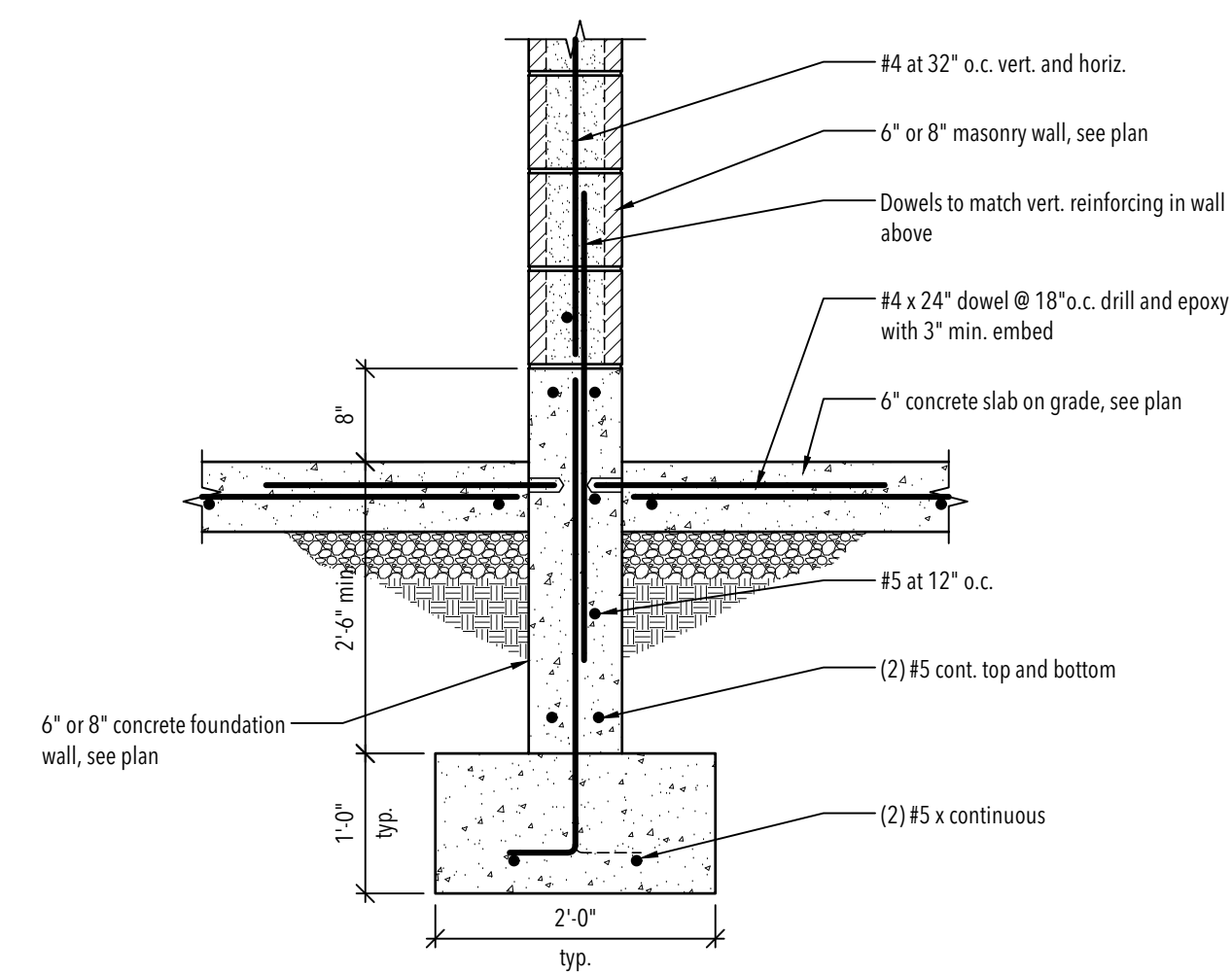

TYPICAL INTERIOR FOOTING

3 Scale: 3/4" = 1'-0"

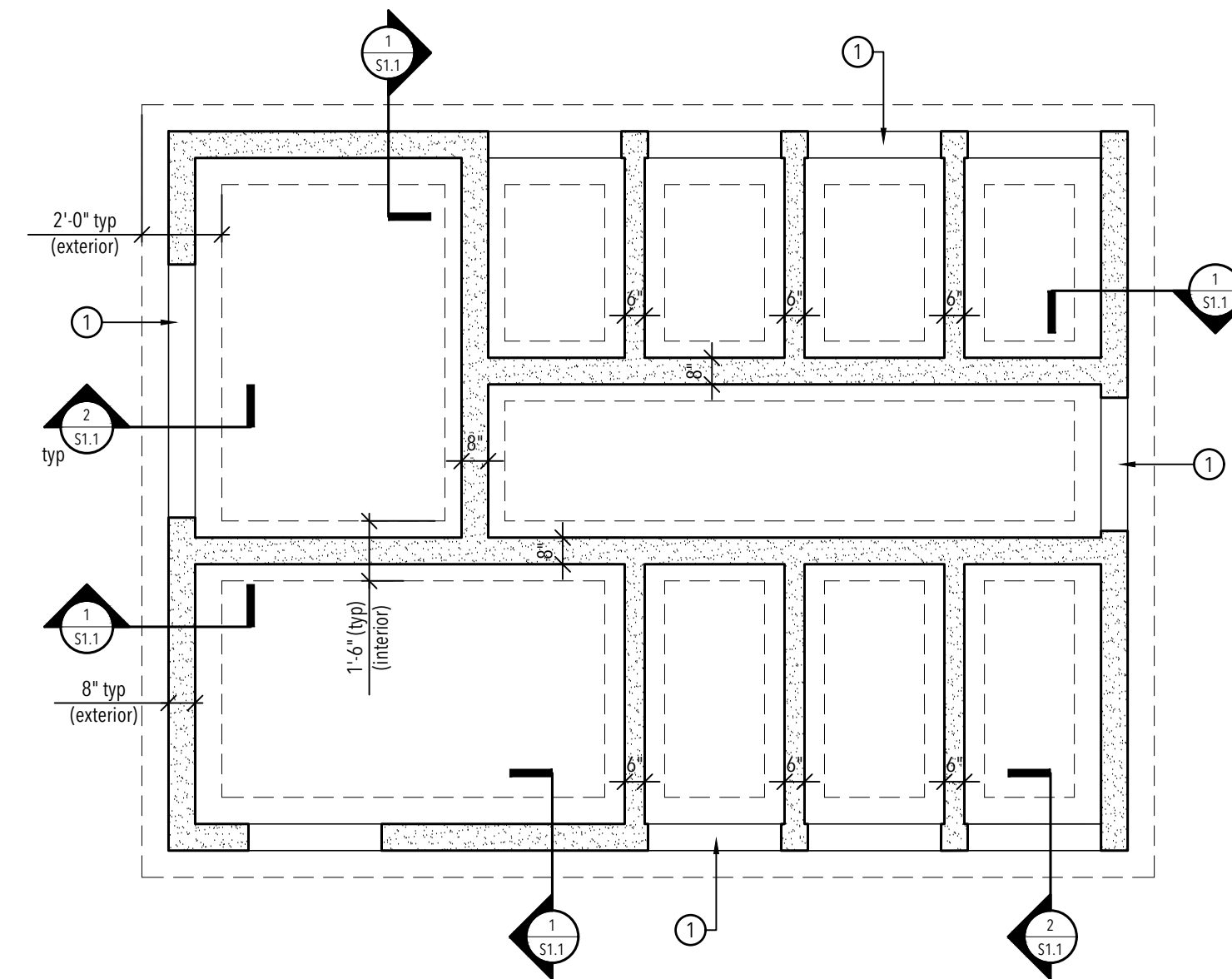

FOOTING AND FOUNDATION PLAN

A Scale: 1/4" = 1'-0"

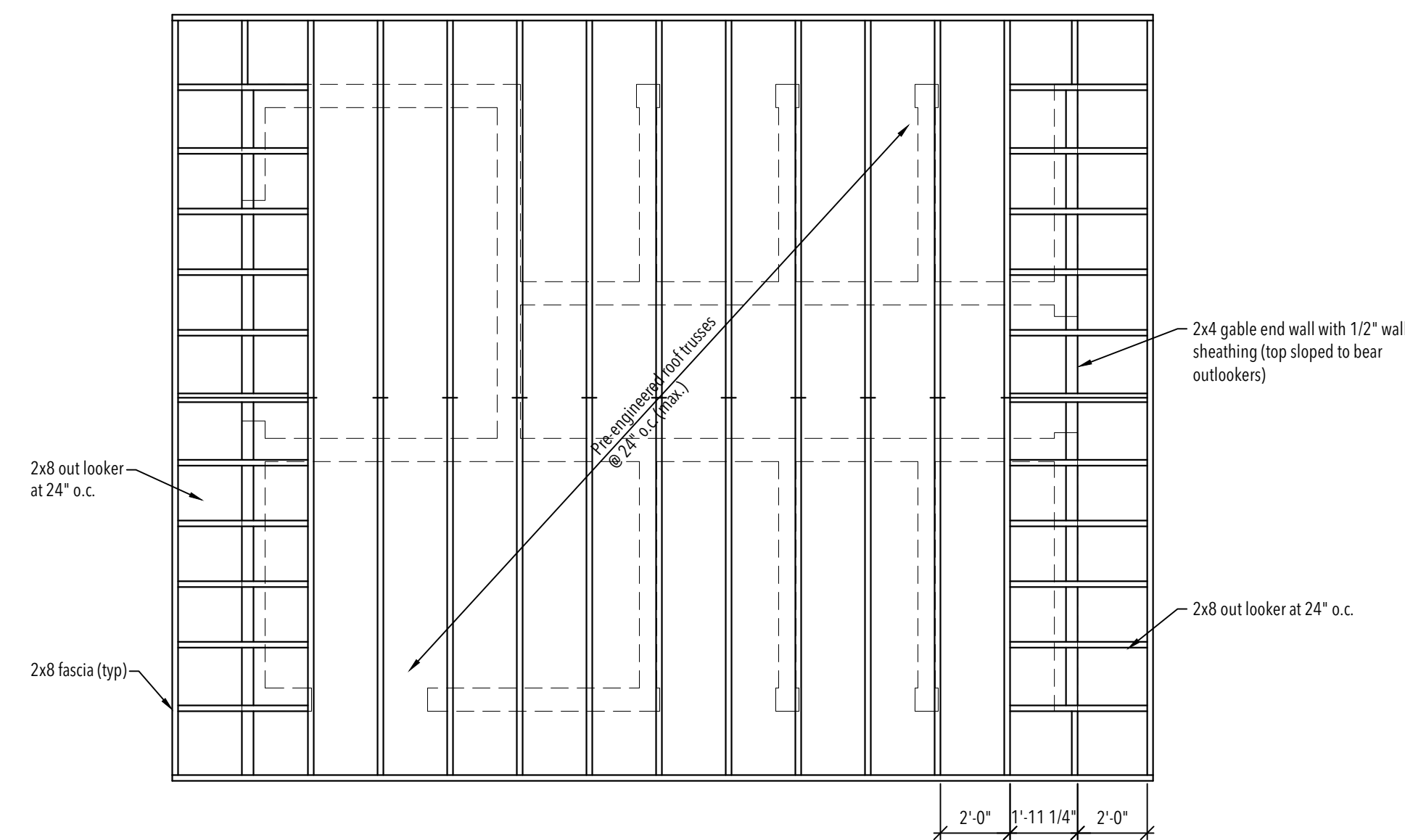

ROOF FRAMING PLAN

B Scale: 1/4" = 1'-0"

GENERAL NOTES:

- A. Footings shall be placed on firm undisturbed natural grade compacted to not less than 95% maximum density based on modified proctor ASTM-1557 or engineered fill compacted in lifts per specification. The bearing capacity of the soils is not at least 1500 psf contact the architect for recommendations.
- B. Concrete for inside floor slabs shall have minimum compressive strength of 4500 psi within 28 days after placement. concrete shall have an air content (do not air entrain) of 6% + or - 1 1/2% and a maximum of 4" slump.
- C. Concrete for exterior footings and foundation walls shall have a minimum compressive strength of 4,500 psi within 28 days after placement.
- D. Concrete for outside sidewalks on grade shall have a minimum compressive strength of 4500 psi within 28 days after placement. Concrete shall have an air entrainment content of 6% + or - 1 1/2% and a maximum of 4" slump.
- E. All metal reinforcement for concrete shall be deformed bars and shall conform to A.S.T.M. #615 grade 60 with a minimum yield strength of 60,000 psi.
- F. Slabs on grade shall be 6" thick or shall bear on a 4 inch layer of compacted granular fill.
- G. Roof trusses shall be designed by the fabricator for a total load of 140 psf (20 psf dead load and 120 psf live load - dead load shall be 10 psf to the top chord and 10 psf to the bottom chord). Do not fabricate trusses until architect has returned the approved shop drawings. Fabricator shall supply shop drawings of the final design to owner. Shop drawings shall be stamped by a certified structural engineer in state of construction.
- H. Anchor bolts or framing bolts shall comply with ASTM #307 and shall be the size and length called out on the drawings.
- I. Roof sheathing shall be 3/4" thick cdx plywood with span rating of 48/20 & blocked with flat 2x4 members at all unsupported edges. nail with 10d nails at 4" on center at the boundaries of structure, 6" on center at all edges of panels and at 12" on center at the intermediate framing members. It shall comply with standard ps-1 of the american plywood association (apa).
- J. Miscellaneous structural steel shall conform with astm #36 grade with a minimum strength of 36,000 psi.

KEYED NOTES:

1. Step down foundation at all door openings and pour slab over - re: 2/S1.1

NO.	DATE	DESCRIPTION

- PLUMBING GENERAL NOTES:**
1. All plumbing shall comply with the most stringent of applicable codes, ordinances, and the specifications.
 2. Entire system must drain due to freezing temperatures.
 3. Due to close proximity of water, vent and drain piping, all trades must coordinate work to facilitate system drainage and access to all valves and fixtures.
 4. All fittings and pipes exposed and mounted to walls, see plumbing details sheet P2.1.
 5. Two restroom/shower buildings are to be constructed as part of this project. See civil drawings for locations. Coordinate building orientation on-site with owner and architect. Flow of drain lines may be reversed from direction indicated if required by building's orientation and location of septic drain field.

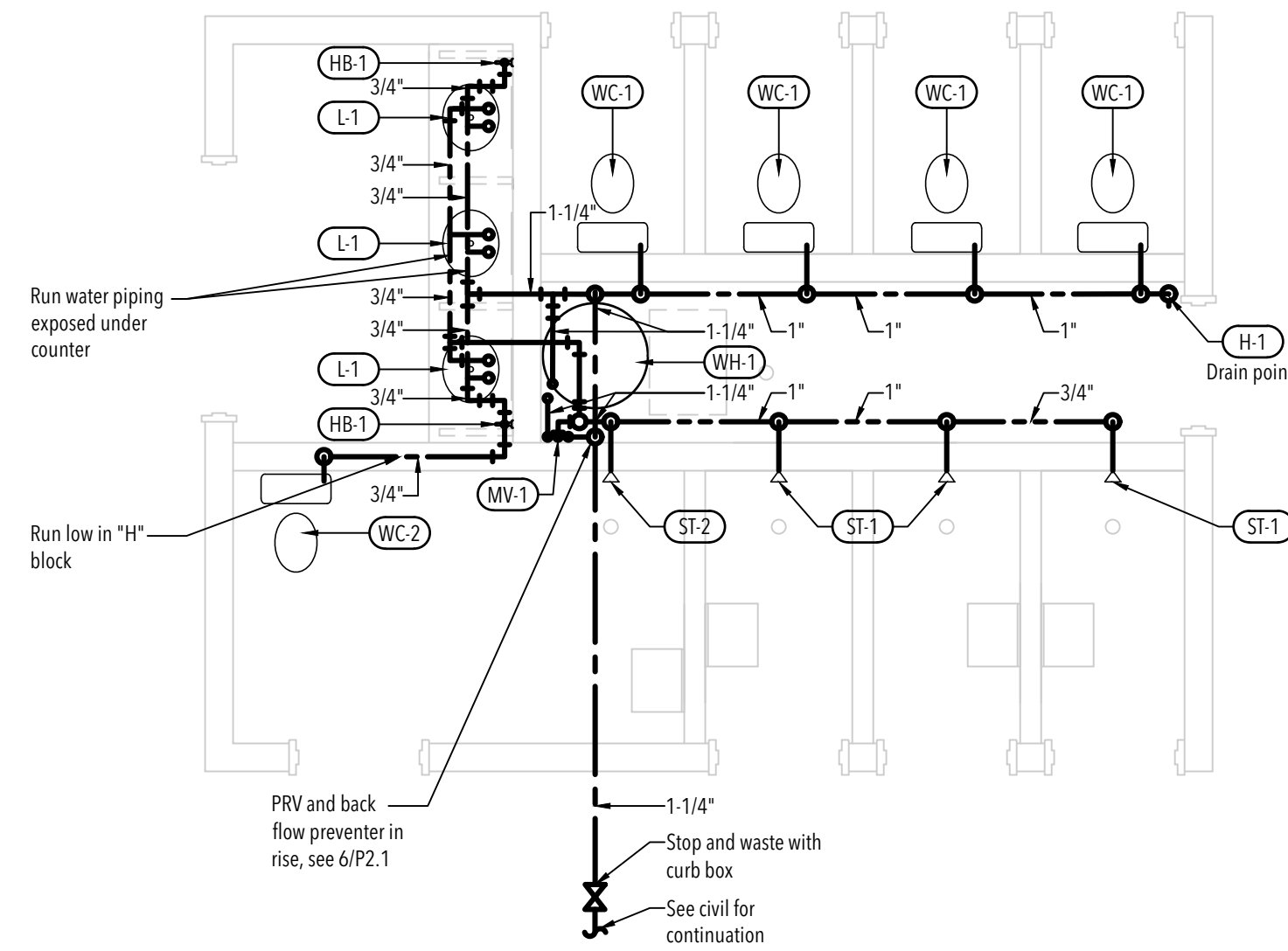

HOT AND COLD WATER PIPING PLAN

1 Scale: 1/4" = 1'-0"

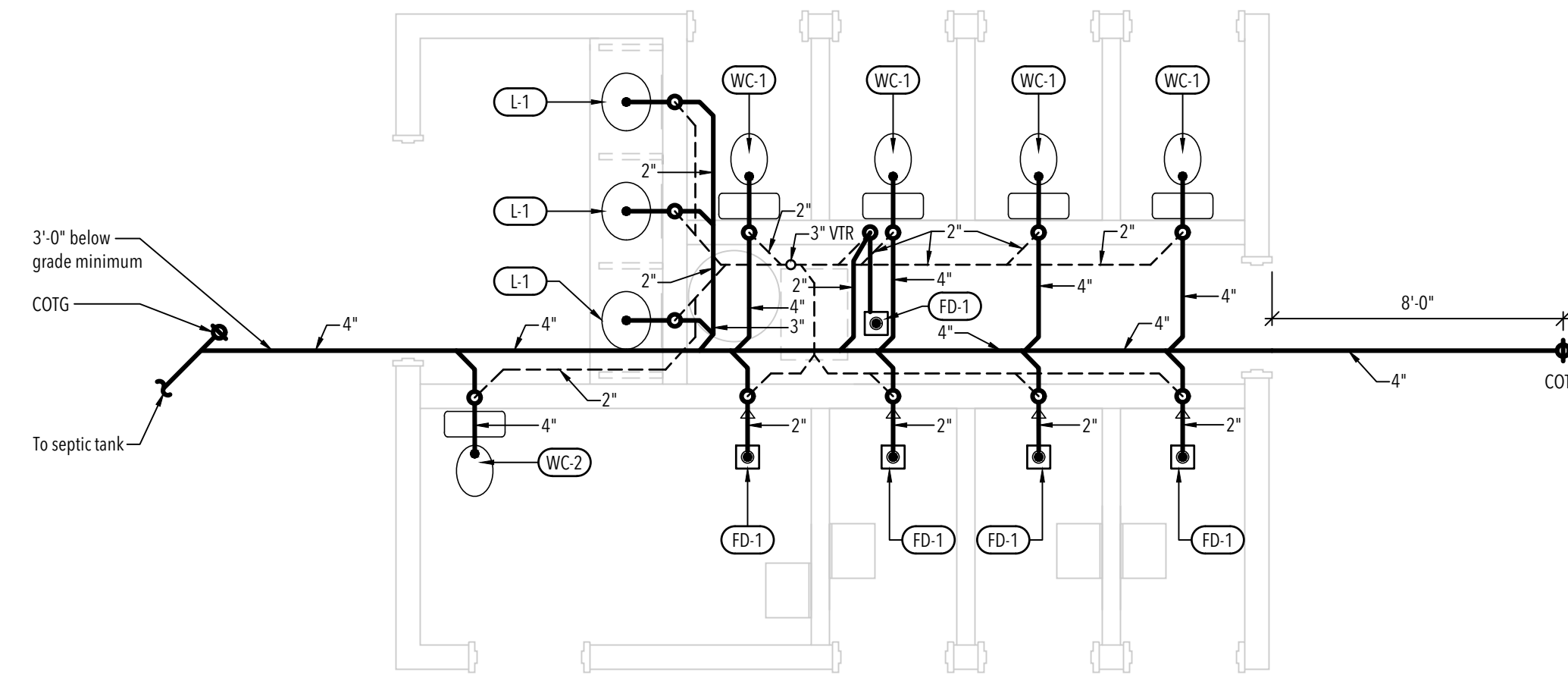

WASTE AND VENT PIPING PLAN

2 Scale: 1/4" = 1'-0"

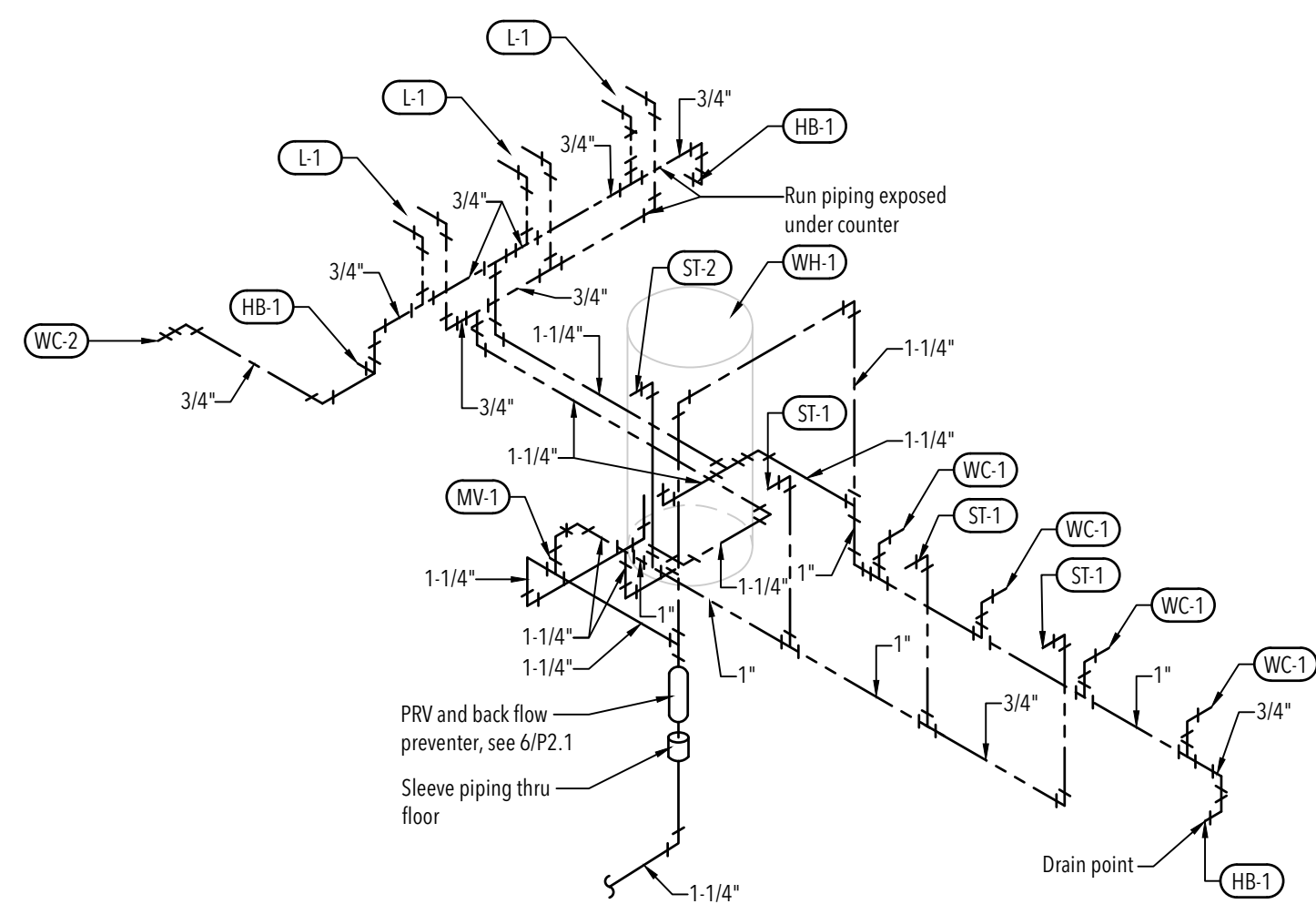

HOT AND COLD WATER PIPING ISOMETRIC

3 Scale: 1/4" = 1'-0"

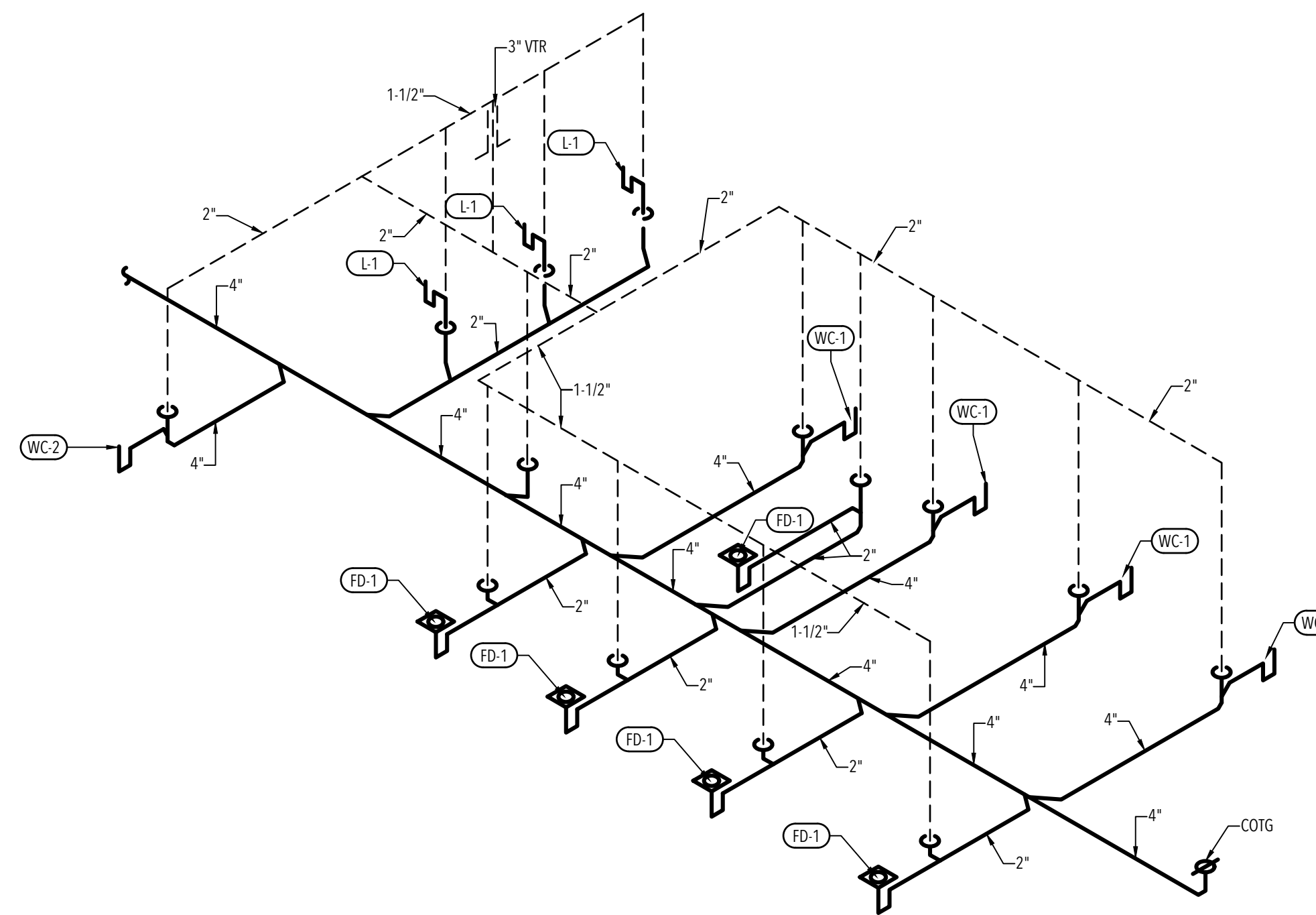

WASTE AND VENT PIPING ISOMETRIC

4 Scale: 1/4" = 1'-0"

NO.	DATE	DESCRIPTION

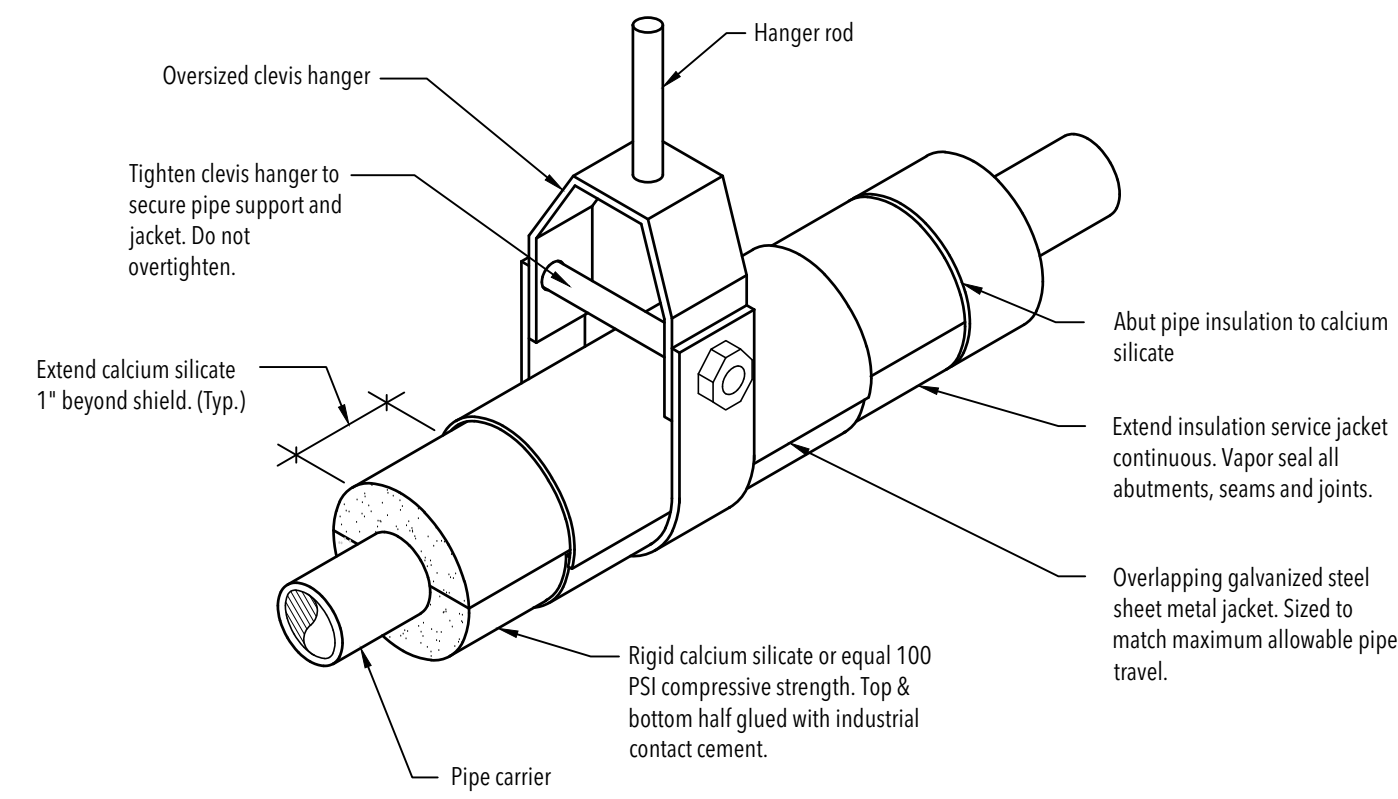

SUSPENDED COPPER DOMESTIC WATER PIPE SUPPORT DETAIL

1 Scale: none

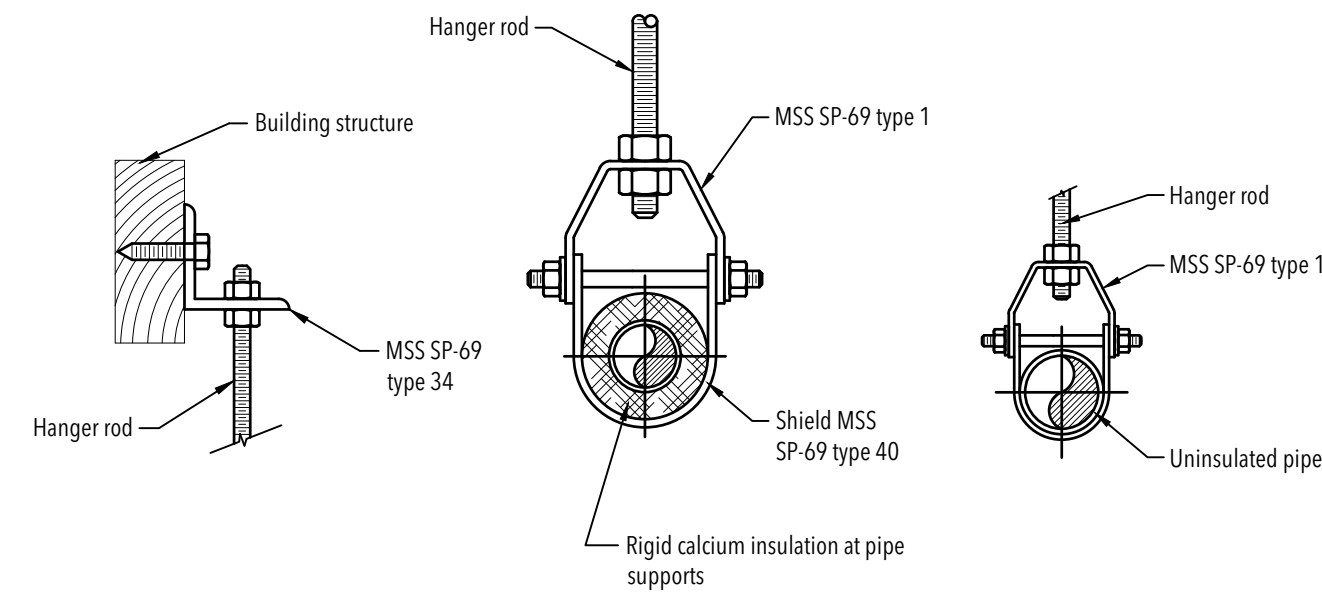

SUSPENDED PIPE SUPPORT DETAIL

2 Scale: none

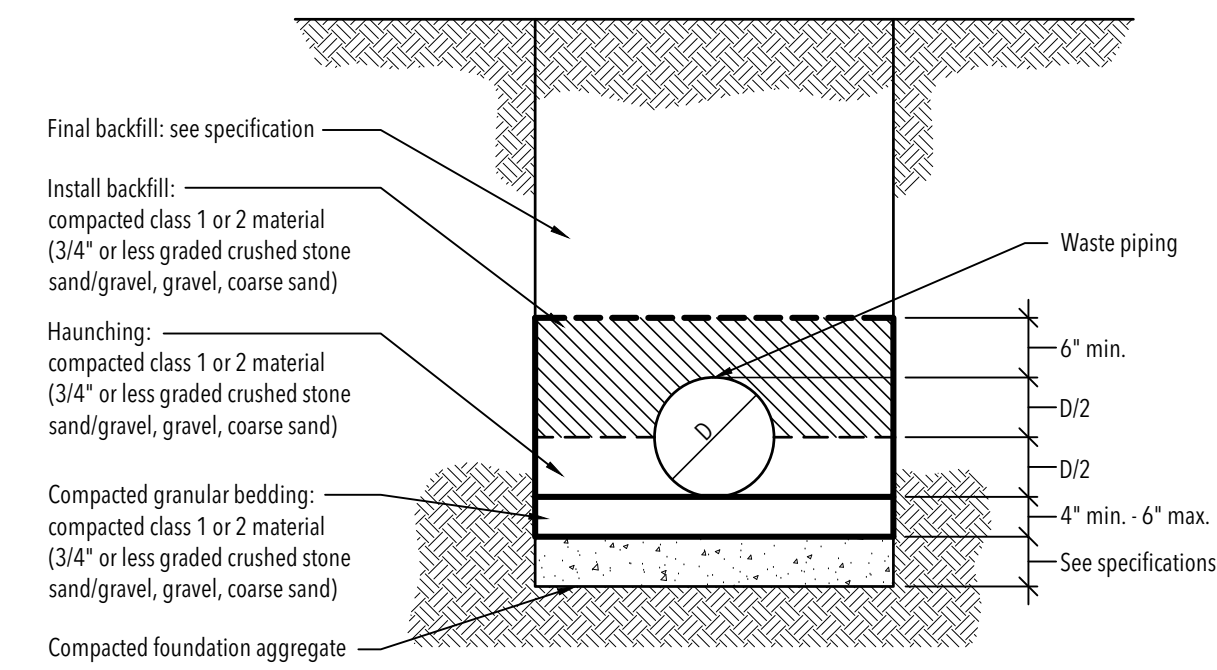

TYPICAL BACKFILL FOR WASTE PIPING

3 Scale: none

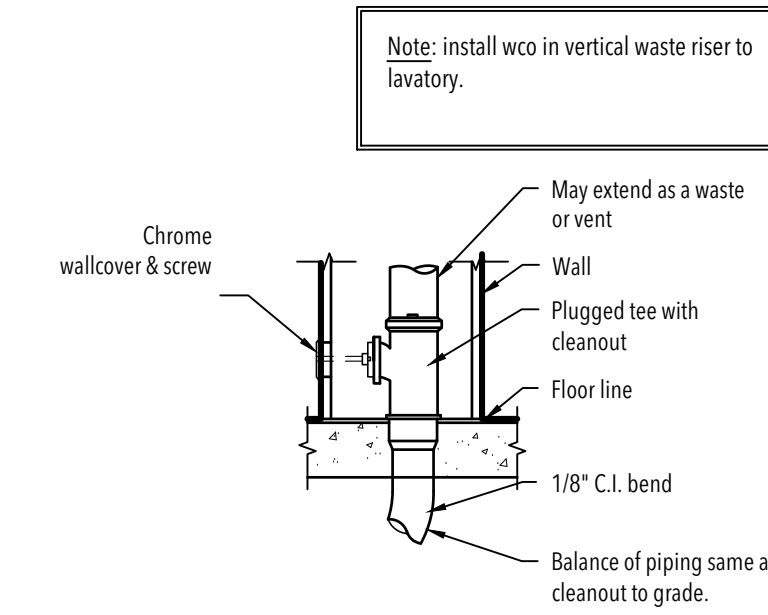

WALL CLEANOUT DETAIL

4 Scale: none

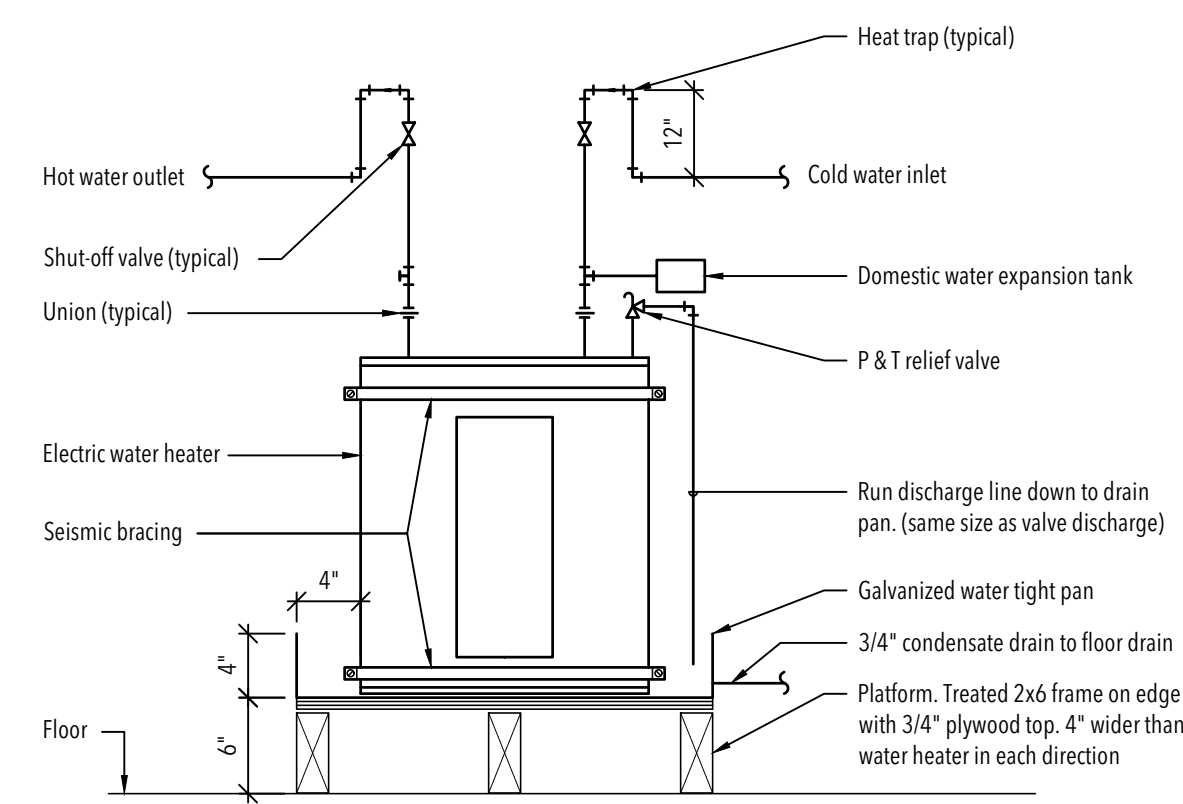

ELECTRIC HOT WATER HEATER DETAIL

5 Scale: none

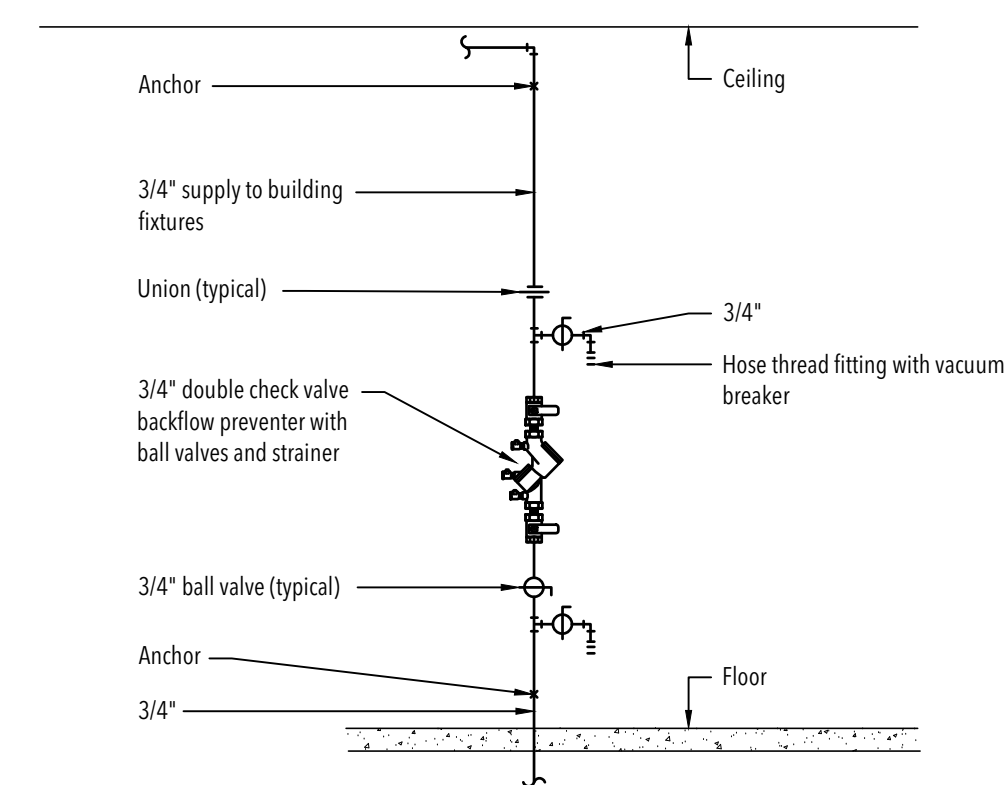

WATER SUPPLY RISER AND BACKFLOW PREVENTER DETAIL

6 Scale: none

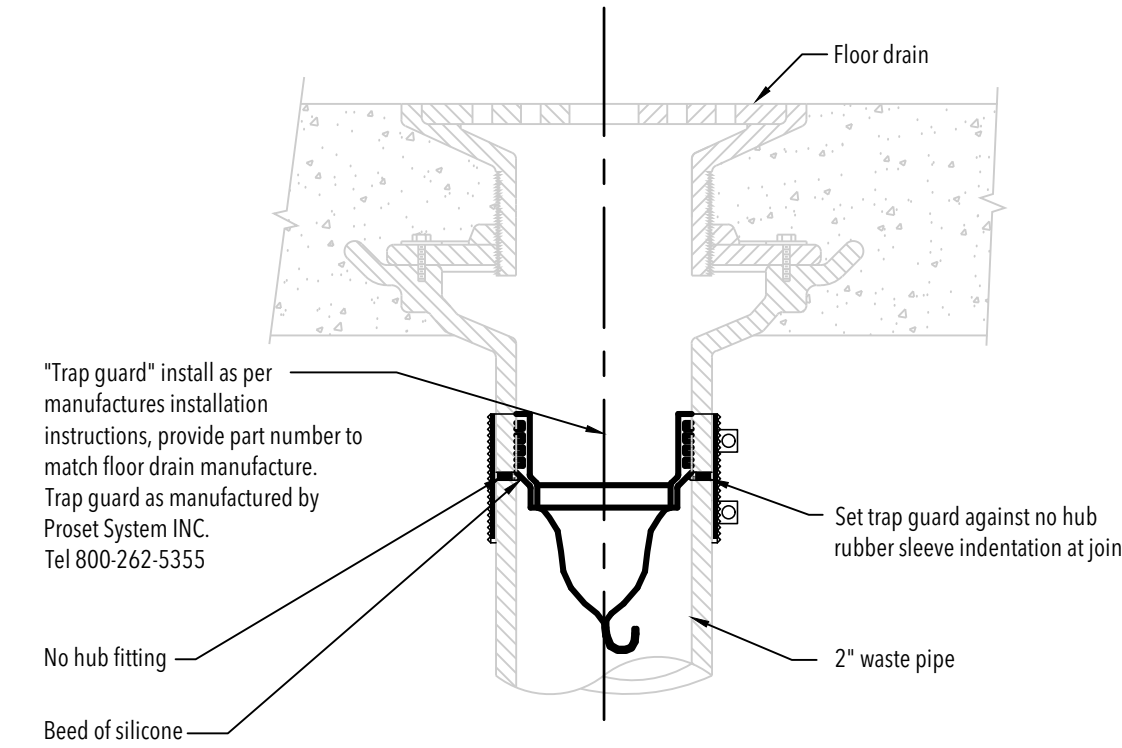

TRAP GUARD TRAP SEAL DETAIL

7 Scale: none

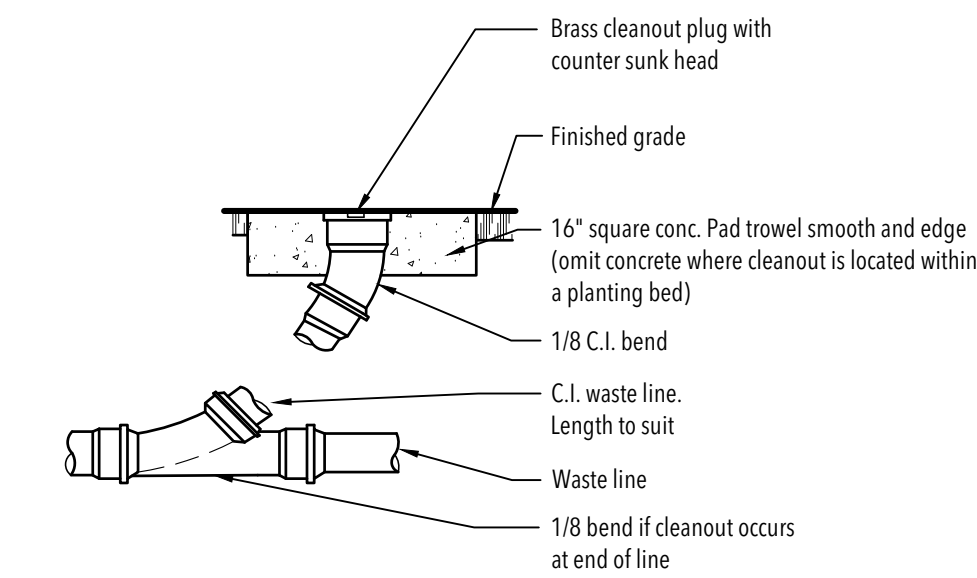

CLEANOUT TO GRADE DETAIL

8 Scale: none

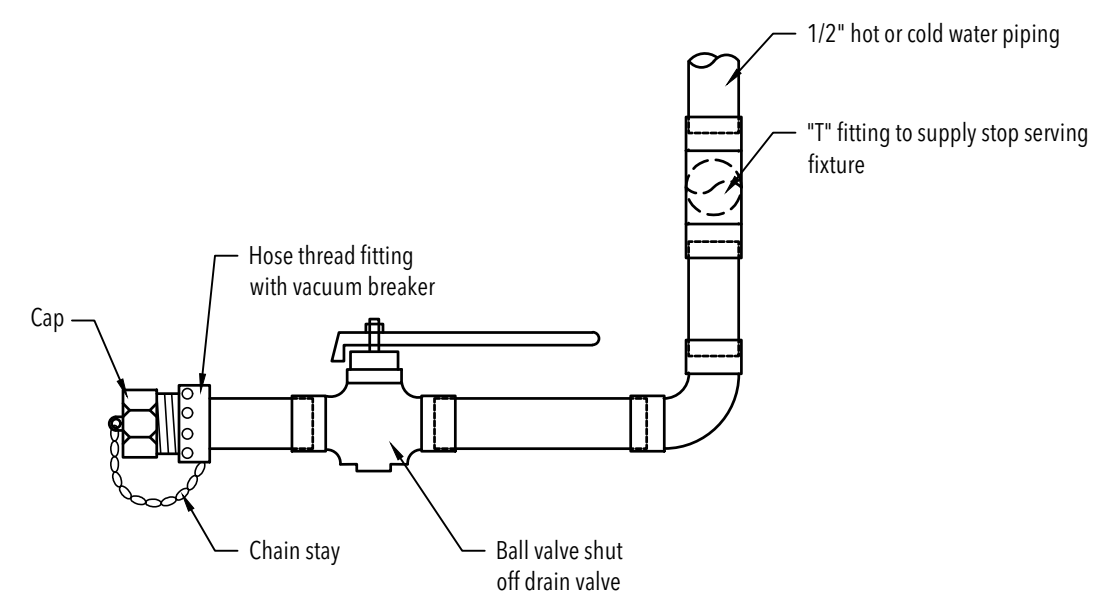

TYPICAL END OF LINE DRAIN VALVE DETAIL

9 Scale: none

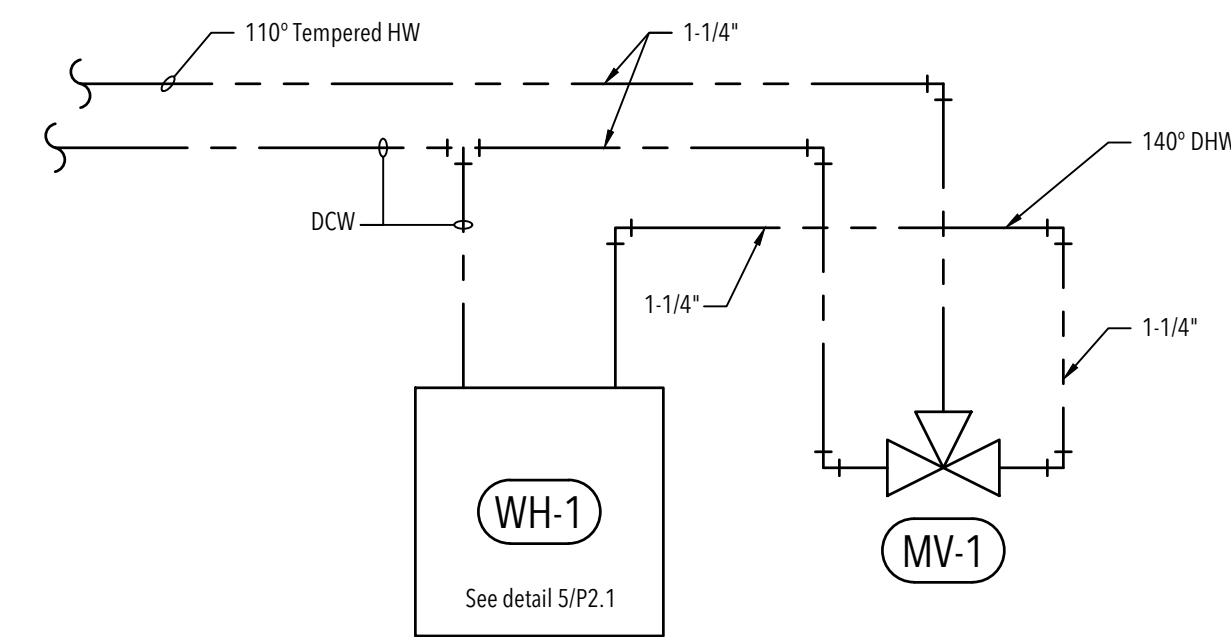

WATER HEATER SCHEMATIC

10 Scale: none

PLUMBING FIXTURE SCHEDULE							REMARKS	A.D.A
MARK	FIXTURE	PIPE SIZE						
		TRAP	WASTE	VENT	C.W.	H.W.		
WC-1	Water closet	Int.	4"	2"	1/2"		Tank type	
WC-2	Water closet	Int.	4"	2"	1/2"		Tank type	♿
L-1	Lavatory	1-1/2"	1-1/2"	1-1/4"	1/2"	1/2"	19" lavatory with 4" o.c. faucet holes	♿
FD-1	Floor drain	2"	2"	1-1/2"			With trap guard see 7/P2.1	
SF-1	Shower				1/2"	1/2"	Shower trim & fittings	
SF-2	Shower				1/2"	1/2"	Shower trim & fittings	♿
HB-1	Hose Bibb				3/4"		Hose Bibb service faucet Chicago faucet 952	
MV-1					1-1/4"	1-1/4"	Mounted adjacent to WH-1. Set discharge temperature at 110°F. Meets ASSE 1017	
WH-1	Water heater				1-1/4"	1-1/4"	Electric, 240V single phase with 24kW element, set discharge at 140°F. see detail 5 & 10/P2.1 A.O. Smith, 119 Gallon, model DRE-120. See detail 5/P2.1.	

♿ Denotes fixture for people with disabilities.

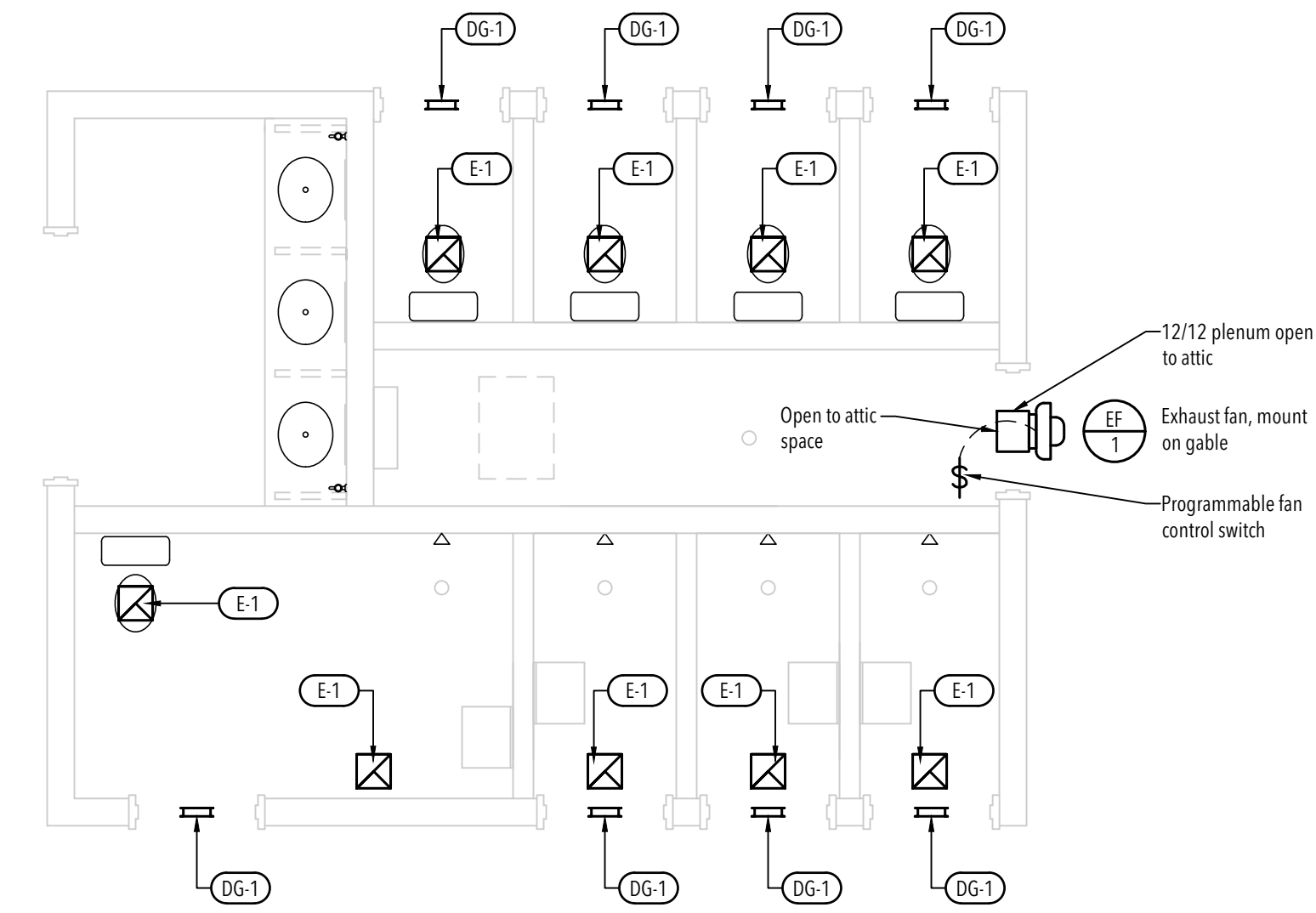

MECHANICAL EXHAUST AIR PLAN

Scale: 1/4" = 1'-0"

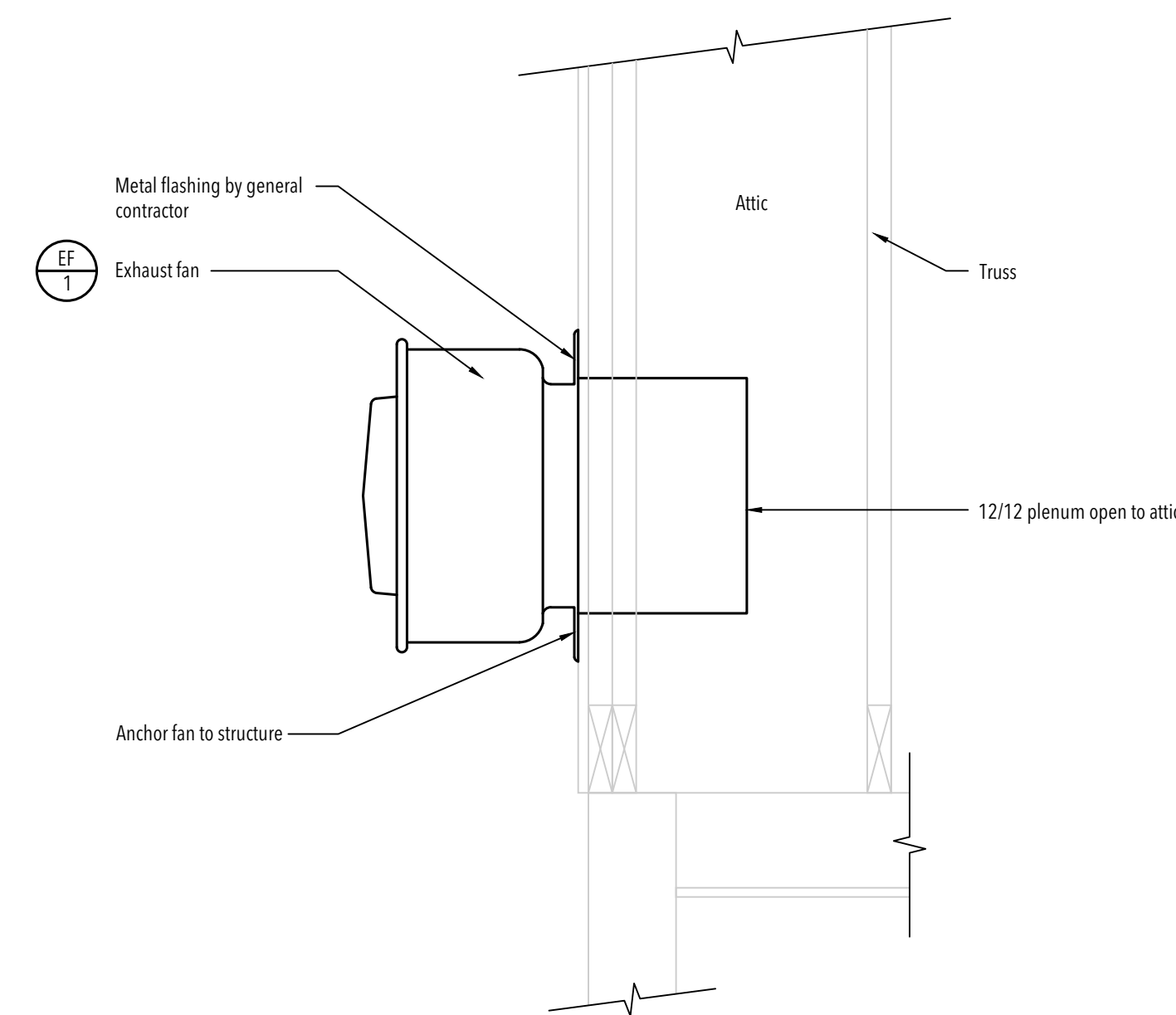

SIDE WALL EXHAUST FAN

Scale: none

EXHAUST FAN SCHEDULE

MARK	CFM	STATIC PRESS. IN. W.G.	MAX FAN RPM	MOTOR					CONTROL	TYPE	MANUFACTURER & MODEL
				HP	PH	HZ	VOLT	RPM			
EF-1	750	25	1550	1/8"	1	60	120	1550	PROGRAMMABLE TIMER	WALL	GREENHECK 6095D

- ① Furnish with bird screen.
- ② Furnish with back draft damper.
- ③ Furnish with programmable timer control. Intermatic ST01C, 24 hour 7 day digital timer with up to 40 on/off events per week. Shall have battery back up and manual override.

GRILLE SCHEDULE

MARK	TYPE	SERVICE	NECK SIZE	MANUFACTURERS CATALOG NUMBER
E-1	CEILING	EXHAUST AIR	8" x 8"	NAILOR 6145-HD
DG-1	DOOR	TRANSFER AIR	10" x 10"	NAILOR 61 DG

- ① Door grilles dimensions list the horizontal dimension first.

NO.	DATE	DESCRIPTION