

Intermountain Riverton Hospital – ASC Conversion

3741 W 12600 S | RIVERTON, UTAH

OWNER

Intermountain Healthcare
36 S State Street, 23rd Floor | Salt Lake City, Utah

DATE

01 September 2022

THIS PAGE LEFT BLANK INTENTIONALLY

TABLE OF CONTENTS

DIVISION AND SECTION	TITLE
DIVISION 00	PROCUREMENT AND CONTRACT REQUIREMENTS
Section 00 4000	Bid Form
Section 00 4373	Schedule of Values
Section 00 5200	Owner/Contractor Agreement
Section 00 6000	Bonds and Certificates
Section 00 6276.13	Exemption Certificate
Section 00 7000	General Conditions
Section 00 7301	Access and Confidentiality Agreement
Section 00 7302	Third Party Remote Access Form
	Pre-Construction Work Permit – Above Ceiling
	Pre-Construction Work Permit – Hot work
	Pre-Construction Work Permit – Infection Control Risk Assessment
	Pre-Construction Work Permit – Interim Life Safety Measures Work
Permit	
DIVISION 01	GENERAL REQUIREMENTS
Section 01 1100	Summary of Work
Section 01 1101	Preconstruction Responsibility Matrix
Section 01 1900	Definitions and Standards
Section 01 2600	Contract Modification Procedures
Section 01 2900	Payment Procedures
Section 01 3100	Project Management and Coordination
Section 01 3300	Submittal Procedures
Section 01 5000	Temporary Facilities and Controls
Section 01 6000	Product Requirements
Section 01 7300	Execution
Section 01 7301	Pre-Construction Safety Requirements
Section 01 7329	Cutting and Patching
Section 01 7700	Closeout Procedures
Section 01 7701	Record Drawing Requirements
DIVISION 02	EXISTING CONDITIONS
Section 02 4102	Selective Demolition
DIVISION 03	CONCRETE
Not Used	
DIVISION 04	MASONRY
Not Used	
DIVISION 05	METALS
Section 05 5000	Metal Fabrication

DIVISION 06**WOOD, PLASTICS, AND COMPOSITES**

Section 06 1053 Miscellaneous Rough Carpentry
Section 06 2000 Finish Carpentry
Section 06 4023 Interior Architectural Woodwork

DIVISION 07**THERMAL AND MOISTURE PROTECTION**

Section 07 2116 Blanket Insulation
Section 07 8400 Through-Penetration Firestop Systems
Section 07 8443 Fire-Resistant Firestops and Joint Systems
Section 07 9200 Joint Sealants

DIVISION 08**OPENINGS**

Section 08 1113 Hollow Metal Doors and Frames
Section 08 1416 Flush Wood Doors
Section 08 3100 Access Doors and Frames
Section 08 7100 Door Hardware
Section 08 8000 Glazing
Section 08 8816 Vision Control Glass

DIVISION 09**FINISHES**

Section 09 2216 Non-Structural Metal Framing
Section 09 2900 Gypsum Board
Section 09 3013 Ceramic Tile
Section 09 5100 Acoustical Ceilings
Section 09 6513 Resilient Wall Base and Accessories
Section 09 6516 Resilient Floor Coverings
Section 09 9100 Painting
Section 09 9124 Sherwin Williams Contractor Job Tracking From

DIVISION 10**SPECIALTIES**

Section 10 2123 Cubicle Tracks and Curtains
Section 10 2613 Corner Guards
Section 10 2623.13 Impact Resistant Wall Protection
Section 10 2800 Toilet and Bath Accessories
Section 10 4400 Fire-Protection Specialties

DIVISION 11**EQUIPMENT**

Section 11 7013 Medical Equipment
Section 11 7014 Equipment Schedule

DIVISION 12**FURNISHINGS**

Section 12 9000 Building Accessories

DIVISIONS 13 - 14

Not Used

DIVISION 21

FIRE SUPPRESSION

Section 21 1000

Water-Based Fire-Suppression Systems

DIVISION 22

PLUMBING

Section 22 0500

Common Work Results for Plumbing

Section 22 0513

Common Motor Requirements for Plumbing Equipment

Section 22 0517

Sleeves and Seals for Plumbing Piping

Section 22 0518

Escutcheons for Plumbing Piping

Section 22 0523

General Duty Valves for Plumbing Piping

Section 22 0529

Hangers and Supports for Plumbing Piping and Equipment

Section 22 0548

Vibration and Seismic Control for Plumbing Piping and Equipment

Section 22 0553

Identification for Plumbing Piping and Equipment

Section 22 0719

Plumbing Piping Insulation

Section 22 1116

Domestic Water Piping

Section 22 1119

Domestic Water Piping Specialties

Section 22 1316

Sanitary Waste and Vent Piping

Section 22 1319

Sanitary Waste Piping Specialties

Section 22 6113

Compressed-Air Piping for Laboratory and Healthcare Facilities

Section 22 6213

Vacuum Piping for Laboratory and Healthcare Facilities

Section 22 6314

Medical Gas Piping

DIVISION 23

HEATING, VENTILATION, AND AIR CONDITIONING

Section 23 0100

Mechanical Requirements

Section 23 0150

Temporary Use of Equipment and Systems

Section 23 0500

Common Work Result for HVAC

Section 23 0513

Common Motor Requirements for HVAC Equipment

Section 23 0517

Sleeves and Sleeve Seals for HVAC Piping

Section 23 0518

Escutcheons for HVAC Piping

Section 23 0519

Meters and Gages for HVAC

Section 23 0523

General-Duty Valves for HVAC Piping

Section 23 0529

Hangers and Supports for HVAC Piping and Equipment

Section 23 0548

Vibration and Seismic Controls for HVAC

Section 23 0550

Operation and Maintenance of HVAC Systems

Section 23 0553

Identification for HVAC Piping and Equipment

Section 23 0593

Testing, Adjusting, and Balancing for HVAC

Section 23 0713

Duct Insulation

Section 23 0719

HVAC Piping Insulation

Section 23 0900

Instrumentation and Control for HVAC

Section 23 2113

Hydronic Piping

Section 23 2116

Hydronic Piping Specialties

Section 23 3001

Common Duct Requirements

Section 23 3113

Metal Ducts

Section 23 3300

Air Duct Accessories

Section 23 3423

HVAC Power Ventilators

Section 23 3600

Air Terminal Units

Section 23 3713

Diffusers, Registers, and Grilles

DIVISION 26**ELECTRICAL**

Section 26 0519	Low-Voltage Electrical Power Conductors and Cables
Section 26 0526	Grounding and Bonding for Electrical Systems
Section 26 0529	Hangers and Supports for Electrical Systems
Section 26 0533	Raceways and Boxes for Electrical Systems
Section 26 0548	Vibration and Seismic Controls for Electrical Systems
Section 26 0553	Identification for Electrical Systems
Section 26 0923	Lighting Control Devices
Section 26 2726	Wiring Devices
Section 26 5119	LED Interior Lighting

DIVISION 27**COMMUNICATIONS**

Section 27 0000	General Common Conditions for All Communication Sections
Section 27 0100	Operation and Maintenance of Communications Systems
Section 27 0113	Warranty, Product and System
Section 27 0119	Field Testing and Reporting
Section 27 0133	Shop Drawings, Product Data, Samples Design Records and Existing Conditions
Section 27 0143	Qualifications and Required Training for Contractors and Installers
Section 27 0171	Responsibility and Workmanship of Contractor
Section 27 0500	Common Work Results for Communications
Section 27 0526	Grounding and Bonding for Communications Systems
Section 27 0528	Pathways for Communications Systems
Section 27 0529	Hangers and Supports for Communication Systems
Section 27 0533	Conduits and Back Boxes for Communications Systems
Section 27 0536	Cable Trays for Communications Systems
Section 27 0543	Campus Cable Routing
Section 27 0553	Identification for Low-Voltage Cables and Labeling
Section 27 1100	Equipment Room Fittings
Section 27 1116	Cabinets, Racks, Frames, and Enclosures
Section 27 1119	Termination Blocks and Patch Panels
Section 27 1300	Backbone Cabling
Section 27 1500	Horizontal Cabling
Section 27 1513	Copper Cable
Section 27 1543	Faceplates and Connectors
Section 27 1619	Patch Cables
Section 27 5223	Nurse Call/Code Blue Systems
Section 27 5319	Internal Cellular, Paging and Antenna Systems
Section 27 6001	Appendix 01 – Deviation Request Process
Section 27 6002	Appendix 02 – Document Refresh Process
Section 27 6003	Appendix 03 – Data Center, Tec, TDR Part Numbers
Section 27 6004	Appendix 04 – Reference Standards
Section 27 6005	Appendix 05 – Definitions and Abbreviations
Section 27 6006	Appendix 06 – Material Suppliers
Section 27 6007	Appendix 07 – Siemon Certified Installation Firms
Section 27 6008	Appendix 08 – Lead Wall Penetrations

DIVISION 28**ELECTRONIC SAFETY AND SECURITY**

Section 28 1300	Access Control Section 28 2300 Video Surveillance
Section 28 2300	Video Surveillance
Section 28 3111	Digital, Addressable Fire-Alarm System

DIVISIONS 31 thru 48

Not Used

END OF TABLE OF CONTENTS

THIS PAGE LEFT BLANK INTENTIONALLY

SECTION 00 4000

BID FORM

TO: **IHC Health Services, Inc.** (Intermountain Healthcare)
Facility Design and Construction (FD&C)
36 South State Street, 16th Floor
Salt Lake City, Utah 84111-1486

Attention: Stephanie Joyner
Email: Stephanie.Joyner@imail.org

PROJECT: **Intermountain Healthcare Riverton Hospital
Ambulatory Surgery Center Conversion**
3741 W 12600 S
Riverton, UT 84065

NAME OF BIDDER: _____

BIDDER ADDRESS: _____

DATE: _____

The undersigned, in compliance with your Invitation To Bid, having examined the Drawings and Specifications (Contract Documents) and related documents and the site of the proposed work and being familiar with all of the conditions surrounding the construction of the proposed project, including the availability of labor, hereby propose to furnish all labor, materials, services, equipment and appliances required in connection with or incidental to the construction of the above named project in strict conformance with the following specification and drawings:

Instructions to Bidders, General Conditions, Supplemental General Conditions, and Specification Divisions as shown and all applicable addenda and Drawings as listed on the drawing cover sheets as prepared by VCB O Architecture.

I/We certify, by signing this BID FORM that I/We have a working relationship with the proposed subcontractors and that Bids were not solicited from; and/or the received Contract Documents were not listed in any Plan Rooms for distribution to subcontractors broadly.

BASE BID – for the Riverton Hospital ASC Conversion for Intermountain Healthcare:

For Work of the contract listed above and shown on the Drawings and described in the Project Manual, I/We agree to perform for the sum of:

_____ Dollars (\$ _____)

(In the case of discrepancy, written amount shall govern)

CONTRACTOR’S PROPOSED CONSTRUCTION TIME PERIOD:

This Bid requires a construction time in **calendar days** from the date of authorization of _____ calendar days. The anticipated date of Substantial Completion is thus _____, 20____.

ADDENDA:

I/We acknowledge receipt of the following addenda for the above noted Project: ___/___/___/___/___

SCHEDULE OF VALUES:

I/We have attached with this Bid Form our Schedule of Values (Section 00 4373) which reflects the above Base Bid. We submit this for Owner review of subcontractors that are being proposed for this Project.

TYPE OF ORGANIZATION:

(Corporation, Partnership, Individual, etc.) _____

SEAL (If a Corporation)

Respectfully Submitted,

Name of Bidder

Authorized Signature

SECTION 00 4373

SCHEDULE OF VALUES

NAME OF BIDDER: _____

DATE: _____

DIV	TITLE	AMOUNT	\$/SQ. FT	COMMENTS
01	General Conditions	\$ _____	\$ _____	
02	Demolition	\$ _____	\$ _____	
06	Woods and Plastics	\$ _____	\$ _____	
07	Thermal and Moisture Protection	\$ _____	\$ _____	
08	Openings	\$ _____	\$ _____	
09	Finishes	\$ _____	\$ _____	
10	Specialties	\$ _____	\$ _____	
12	Furnishings	\$ _____	\$ _____	
21	Fire Suppression	\$ _____	\$ _____	
22	Plumbing	\$ _____	\$ _____	
23	HVAC	\$ _____	\$ _____	
26	Electrical	\$ _____	\$ _____	
	SUBTOTAL	\$ _____	\$ _____	
	OVERHEAD AND PROFIT	\$ _____	\$ _____	
	TOTAL COST	\$ _____	\$ _____	

END OF SECTION

THIS PAGE LEFT BLANK INTENTIONALLY

SECTION 00 5200

OWNER/CONTRACTOR AGREEMENT

PART 1 - GENERAL

1.1 SUMMARY

- A. Intermountain Healthcare's '**CONTRACTOR AGREEMENT**' (**Stipulated Sum**) for Construction between the Owner and General Contractor' where the basis of payment is a STIPULATED SUM, will *presumably* be used on this project. A draft version of the Contract form follows this cover.

THIS PAGE LEFT BLANK INTENTIONALLY

**GENERAL CONTRACTOR AGREEMENT
FOR STIPULATED SUM**

IHC HEALTH SERVICES, INC., a Utah non-profit corporation (“Intermountain”), located at 36 S. State Street, Salt Lake City, Utah 84111, and _____, a _____ (“Contractor”), located at _____, enter this GENERAL CONTRACTOR AGREEMENT FOR STIPULATED SUM (this “Agreement”) on _____, 20_____, in connection with the following “Project”:

Project Name/Number: _____

Project Description: _____

1. SCOPE OF THE WORK.

- A.** Contractor will furnish all labor, materials, equipment, construction, and services necessary to complete the work in accordance with the Contract Documents (the “Work”).
- B. In addition, Contractor accepts the relationship of trust and confidence established by this Agreement and covenants** with Intermountain as follows:
- 1) Cooperation.** Contractor will cooperate with Intermountain and with the A/E Intermountain selects.
 - 2) Best Skills, Efforts and Judgments.** Contractor will use Contractor’s best skills, efforts and judgments in furthering Intermountain’s interest.
 - 3) Efficient Business Administration and Supervision.** Contractor will furnish efficient business administration and supervision.
 - 4) Perform the Services and Work.** Contractor will furnish at all times an adequate supply of workers, the appropriate materials and equipment, and perform all services and Work in the best and most expeditious manner in accordance with the Contract Documents.
 - 5) Inspection and Approval.** The Work will be subject to inspection and approval of Intermountain or its authorized representative.
- C. Bonds.** Contractor will supply performance and payment Bonds, if required, as set forth in the General Conditions:
- WILL be required WILL NOT be required
- D. Contractor’s Insurance.** Contractor will procure insurance as specified in the General Conditions. The Project is a:
- Small Project (under \$2M) Medium Project (\$2M – \$10M) Large Project (over \$10M)

- 2. CONTRACT DOCUMENTS.** The Contract Documents consist of the following: (A) this Agreement and all attachments; (B) the Intermountain General Conditions; (C) Supplementary Conditions; (D) Intermountain’s Construction Safety Requirements, Weapon Policy, and Supplier Access Program; (E) the project manual titled _____ prepared by _____ (“A/E”) (including without limitation the drawings and specifications identified within the project manual); (F) addenda dated and numbered _____; and (G) all Modifications to the Contract Documents.

The General Conditions and all Supplementary Conditions may be accessed online via Intermountain’s Digital Information System, the following links: General Conditions-<https://intermountainhealthcare.org/-/media/files/file-hosting/2019-general-Conditions.pdf>, Supplementary Conditions-<https://intermountainhealthcare.org/-/media/files/file-hosting/2019-Supplementary-Conditions-Idaho-and-Nevada.pdf>, or by request. Capitalized terms used in this Agreement without definition have the meanings set forth in the General Conditions.

3. TIME.

- A. Time of Essence.** Time is of the essence for Contractor’s performance required by this Agreement.
- B. Commencement Date:** Contractor will commence the Work on the date for commencement set forth in the Written Notice to proceed from Intermountain to Contractor.

C. Completion Date. Contractor will achieve Substantial Completion and have the Work ready for Intermountain's inspection no later than ____ (____) Days from the date of commencement set forth in the Written Notice to proceed from Intermountain to Contractor, as adjusted in accordance with the Contract Documents.

D. Liquidated Damages. As provided in the General Conditions, liquidated damages for delay in the completion date:

WILL be assessed WILL NOT be assessed

Should liquidated damages not be provided under this Agreement, Intermountain by that choice is not waiving any claims against Contractor for actual damages that may be incurred by Intermountain arising out of Contractor's delay in completion.

If liquidated damages are assessed, liquidated damages will be as follows:

1. The amount of liquidated damages to be paid to the Owner for delays in Substantial Completion under General Conditions Section 4.7.15 a is \$0.00 per Day.
2. The amount of liquidated damages to be paid to the Owner for delays in completing work itemized on the Substantial Completion Certificate under General Conditions Section 4.7.15.b is \$0.00 per Day.

E. Delay/Hindrance Claim Limitation. No Claim or action will be maintained by Contractor, Subcontractors, or suppliers at any tier, against Intermountain for damages or other claims due to losses attributable to hindrances or delays from any cause whatsoever, including acts and omissions of Intermountain or its officers, employees or agents, except as expressly provided in the General Conditions. Contractor, and all Subcontractors and suppliers, hereby release and waive all such claims against Intermountain, and Contractor will contractually obligate all Subcontractor or suppliers of any tier to release and waive all such claims against Intermountain.

4. COMPENSATION AND FEES.

A. Contract Sum. Intermountain will pay Contractor for performance of Contractor's obligations under the Contract Documents the amount of ____ Dollars (____) ("Contract Sum"), as adjusted in accordance with the Contract Documents.

B. Reimbursement of Building Permit Fee. Contractor will pay the Building Permit fee for this Project, and Intermountain will reimburse Contractor for the Building Permit fee upon receiving a separate invoice (with satisfactory evidence of Contractor's actual payment) from Contractor. Contractor will not be entitled to any additional fee or markup on the Building Permit fee.

5. ALLOWANCES.

A. The Contract Sum includes all allowances stated in the Contract Documents. Allowances will be supplied by and in such amounts as may be directed by Owner. Allowance amounts include both labor and material costs.

B. If the actual cost of performing an allowance item is less than the allowance amount for that item, the Contract Sum will be reduced by Modification in the amount of such savings. If the actual cost of performing an allowance item is greater than the allowance amount for that item, the Contract Sum will be increased by Modification in the amount of the increased cost of performing such allowance item. Allowance items are to be specifically identified as such in the Schedule of Values. Specific allowance line item amounts in the Schedule of Values will not be transferred from one line item to another without Owner's consent. Specific allowance line item amounts will not be billed or applied by Contractor without Owner's consent.

C. Intermountain owns all allowances and has the right in its sole discretion to identify, consent to, hold and maintain all allowances as it deems necessary or appropriate.

6. **BASIC SERVICES.** Contractor's Basic Services include the following and any other services set forth in the Contract Documents.
- A. **Construction Phase.**
 1. **Written Authorization to Commence Construction.** Contractor will complete construction in accordance with the Contract Documents prepared by A/E and approved by Intermountain.
 2. **Administrative and Management Services.** Contractor will provide administrative and management services as required to coordinate the Subcontractors' Work with each other and with Contractor, Intermountain and A/E.
 3. **Team Members.** Contractor's team must be consistent with the team members designated in Contractor's proposal and such team must contain an adequate number of members and have the qualifications necessary to complete the project in accordance with this Agreement. No member of Contractor's team submitted in Contractor's selection process will be removed from the Project unless this team member leaves Contractor's employ or unless Intermountain requests or approves the change. Any request to replace a team member will be submitted in writing and subject to approval of Intermountain upon a showing that such replacement is consistent with the qualifications provided in the selection process of Contractor. Contractor will use Intermountain's personnel change request form.
 4. **Supervision.** Contractor will provide competent supervision of the Work and will cause the Work to be performed in accordance with the Contract Documents.
 5. **Meetings.** Contractor will schedule and conduct pre-construction, construction and progress meetings. Contractor will prepare and promptly distribute minutes of all such meetings. These minutes will not be considered official minutes until approved by Intermountain. At the beginning of each meeting, the minutes of the prior meeting will be the first item on the agenda and the minutes will be reviewed for editing or approval at that time.
 6. **Critical Path Scheduling.** Contractor will provide an updated critical path schedule before the commencement of the Work as the baseline schedule. This critical path schedule will be further updated in a prompt manner to reflect any Modification changes as the Work progresses. Contractor will comply with all scheduling requirements in the Contract Documents and the General Conditions.
 7. **Safety.** Contractor will be responsible for the overall safety of and on the Project and will review the safety programs developed by each of the Subcontractors and Intermountain as required by the Contract Documents. Contractor will fulfill the safety responsibilities provided for in the General Conditions and all other safety responsibilities. Contractor will not perform any Work that is unsafe.
 8. **Manage Subcontractors and the Work.** Contractor will determine that each Subcontractor's Work is being performed in accordance with the Contract Documents. Contractor will promptly remediate any defects or deficiencies in the Work. Contractor is solely responsible for all Subcontractors' performance at any tier. Subject to review by A/E and Intermountain, Contractor will reject Work that does not conform to the requirements of the Contract Documents.
 9. **Inspections.** Contractor will timely arrange for all code inspections, special inspections, testing, and all other requirements of authorities having jurisdiction, and as needed to assure compliance with the Contract Documents.
 10. **Requests for Interpretations.** Contractor will promptly submit to A/E and Intermountain any Subcontractor requests for interpretations of the drawings and specifications, and promptly assist in resolving such requests.
 11. **Forward Insurance Certificates.** Contractor will receive documentation and Certificates of Insurance from the Subcontractors, and upon specific request by the Intermountain Representative, forward such to Intermountain.
 12. **Review of Submittals.** Contractor will establish and implement procedures for expediting the processing and approval of shop drawings, product data, samples and other submittals. Contractor will receive from the Subcontractors all shop drawings, product data, samples and other submittals, and review such for

conformance with the Contract Documents. After Contractor's review, Contractor will deliver the submittals to A/E for review.

13. **Logs; Records.** Contractor will keep a daily log containing a record of weather conditions, Subcontractors' Work on the site, number of workers, Work accomplished, all necessary data for verification of Subcontractor performance (including, but not limited to, unit quantities), problems encountered, and other data as Intermountain may require. Contractor will make the log available to Intermountain and A/E promptly upon request.

Contractor will maintain at the Project site, on a current basis: a record copy (each of which will be marked to record all changes made during construction) of all contracts, drawings, specifications, addenda, change orders and other Modifications; all shop drawings; product data; samples; submittals; purchases; materials; equipment; maintenance and operating manuals and instructions; and other related documents and revisions related to the Project. Contractor will make all records promptly available to Intermountain upon request.

14. **Operation and Maintenance (O&M) Records; Record Drawings.** At the Project completion, Contractor will promptly submit to A/E, all O & M manuals and as-built (record drawings). A/E will review these submittals for accuracy and then promptly forward the submittals to Intermountain.
15. **Manage Intermountain-Purchased Items.** Contractor will arrange for delivery, storage, protection, and security for Intermountain-purchased items delivered to Contractor.
16. **Assist with Commissioning.** With Intermountain's designated commissioning agent, A/E, and Intermountain's maintenance personnel, Contractor will observe the Subcontractors' testing and operation of utilities, control systems, and equipment.
17. **Substantial Completion.** Contractor will notify A/E when the Project, or a portion thereof, is ready for a Substantial Completion inspection. Upon Substantial Completion, Contractor will promptly complete the punch list items as provided for in the General Conditions.
18. **Markup Limits for Additional Services or other Modifications.** Markups for additional work, changes, or other Modification will in no event exceed the following limits:
- a. 10% for the Subcontractor or Sub-subcontractor on additional Modification work performed by such Subcontractor or Sub-subcontractor;
 - b. 5% for Subcontractors (of any tier) on the additional Modification work they managed of other Subcontractors;
 - c. 5% for Contractor on all Modification work Contractor managed of Subcontractors (but not chargeable on self-performed work by Contractor);
 - d. 5% for Contractor on additional Modification work self-performed by Contractor.
19. **Contractor to Coordinate with Other Vendors.** Contractor will coordinate and integrate Contractor's Work and services with the schedules, work, and services of other Intermountain vendors.

7. INTERMOUNTAIN'S RESPONSIBILITIES AND ADDITIONAL RIGHTS.

- A. Intermountain-Provided Requirements.** Intermountain has provided the requirements for the Project in the Request for Proposals, which is part of the Contract Documents.
- B. Intermountain Representative.** Intermountain Executive Director of Design & Construction, or designee, will be the designated representative authorized to act upon behalf of Intermountain with respect to the Project. Intermountain Facility Design & Construction Project Manager will examine documents submitted by Contractor and will render decisions pertaining thereto in a timely manner to avoid unreasonable delay in the progress of Contractor's Work as indicated by the Intermountain-approved critical path schedule.
- C. Intermountain-Provided Information and Services.** Intermountain will furnish the information or services specified in Section 2.1 of the General Conditions as necessary or appropriate for the performance of the Work; provided that Intermountain may direct Contractor to obtain any such information or services on

Intermountain's behalf, at Intermountain's cost. Contractor will cooperate with any such tests, inspections, or requests.

8. MISCELLANEOUS.

- A. Independent Contractor.** Contractor is an independent contractor and not an Intermountain employee. Contractor has no authorization, express or implied, to bind Intermountain to any agreement, settlement, liability or understanding whatsoever, nor to perform any acts as agent for Intermountain.
- B. Counterparts; Electronic Signature.** The parties may sign this Agreement in any number of counterparts, each of which when signed and delivered will be deemed an original, and all of which together will constitute one and the same instrument. The parties may sign and deliver this Agreement by facsimile or other electronic means, such as e-mail.
- C. Authority to Execute.** Contractor and Intermountain each represent that the execution of this Agreement and the performance thereunder is within their respective duly authorized powers.

IN WITNESS WHEREOF, the parties hereto have executed this Agreement on the day and year first above written.

INTERMOUNTAIN

IHC HEALTH SERVICES INC.,
a Utah nonprofit corporation

By: _____
Print Name: Clay L. Ashdown
Title: Vice President, Financial Strategy,
Growth and Development

CONTRACTOR

a _____

By: _____
Print Name: _____
Title: _____

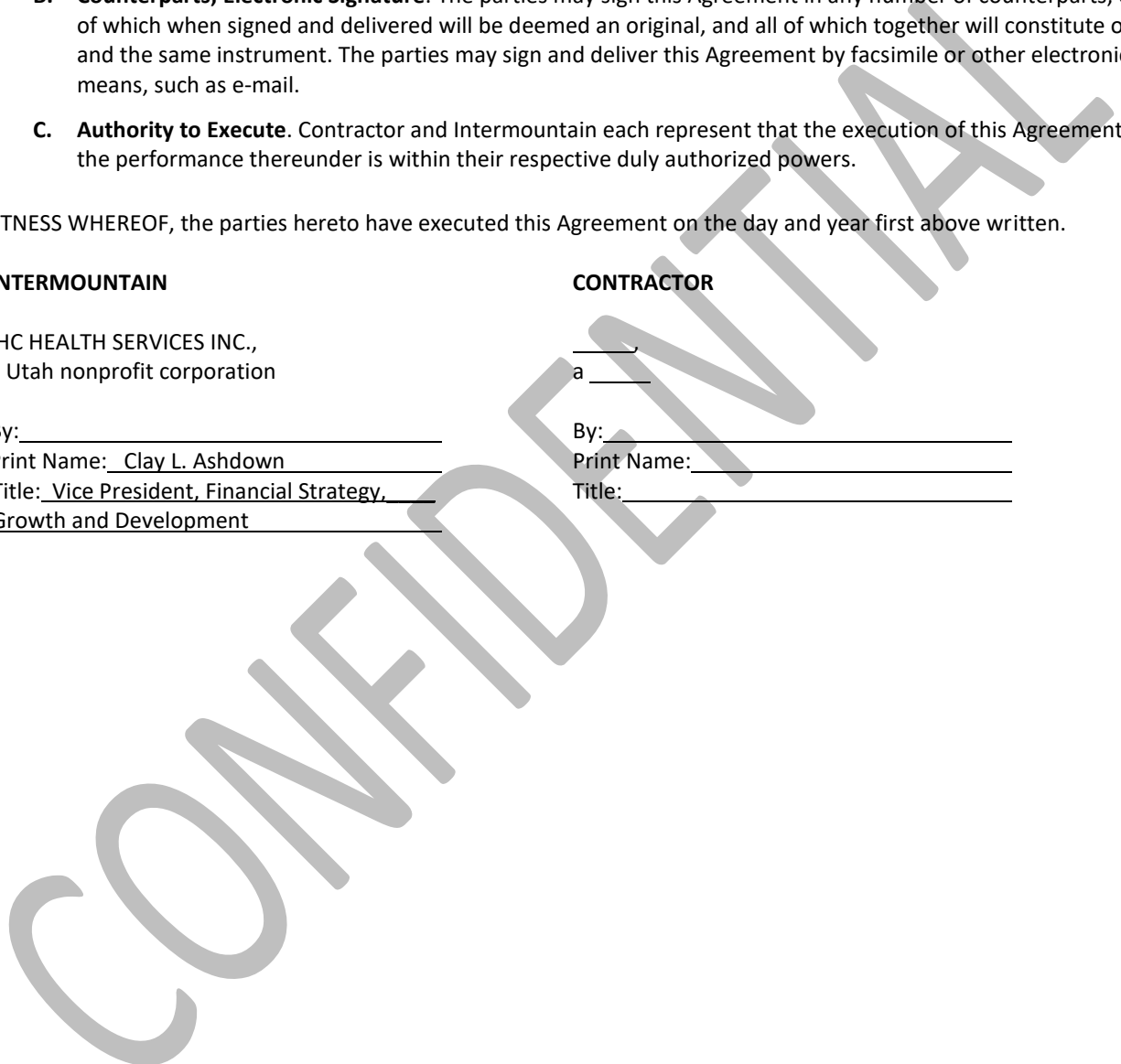

ATTACHMENT A

INDEX TO SPECIFICATIONS AND INDEX TO DRAWINGS

[see attached]

CONFIDENTIAL

ATTACHMENT B

INTERMOUNTAIN'S INVITATION TO BID AND CLARIFICATIONS

[see attached]

CONFIDENTIAL

ATTACHMENT C

CONTRACTOR'S BID FORM, BID CLARIFICATIONS, LIST OF SUBCONTRACTORS AND SCHEDULE

[see attached]

CONFIDENTIAL

ATTACHMENT D

LIEN WAIVER FORMS

[see attached]

CONFIDENTIAL

CONDITIONAL WAIVER AND RELEASE UPON PROGRESS PAYMENT

TO:	IHC HEALTH SERVICES, INC.	("Owner")
FROM:	_____	("Contractor")
PROPERTY NAME:	_____	("Property")
PROPERTY LOCATION:	_____	
CONTRACT DATE:	_____	
INVOICE DATE/NUMBER:		("Invoice")
PAYMENT PERIOD:		
PAYMENT AMOUNT:	\$ _____	("Payment Amount")

Under this Conditional Waiver and Release, Contractor releases Owner and the Property from, and waives, any notice of lien or right under Utah law (see Utah Code Ann., Title 38, Chapter 1a, Pre-construction and Construction Liens, and Utah Code Ann., Title 14, Contractors' Bonds, or Section 63G-6a-1103) related to payment rights the Contractor has on the Property once:

1. Contractor endorses a check in the Payment Amount payable to Contractor or provides valid wire transfer or direct deposit instructions; and
2. The check is paid by the depository institution on which it is drawn or the wired or direct-deposited funds in the Payment Amount are deposited into Contractor's designated account.

This Conditional Waiver and Release applies to the progress payment for the work, materials, equipment, or combination of work, materials, and equipment furnished by Contractor to the Property or to Owner covered by the Invoice. This Conditional Waiver and Release does not apply to any retention withheld; any items, modifications, or changes pending approval; disputed items and claims; or items furnished or invoiced after the Invoice Period.

Contractor warrants that it either has already paid, or will promptly use the Payment Amount received to pay in full all of Contractor's laborers, subcontractors, materialmen, and suppliers for all work, materials, equipment, or combination of work, materials, and equipment under the Invoice. Contractor has not assigned any lien or right to perfect a lien against the Property and has the right, power, and authority to execute this Conditional Waiver and Release.

_____, a _____

By: _____

Print Name: _____

Title: _____

WAIVER AND RELEASE UPON FINAL PAYMENT

TO:	IHC HEALTH SERVICES, INC.	("Owner")
FROM:	_____	("Contractor")
PROPERTY NAME:	_____	("Property")
PROPERTY LOCATION:	_____	
CONTRACT DATE:	_____	
INVOICE DATE/NUMBER:		("Invoice")
PAYMENT PERIOD:		
TOTAL PAYMENT AMOUNT:	\$ _____	("Payment Amount")

Under this Waiver and Release, Contractor releases Owner and the Property from, and waives, any notice of lien or right under Utah law (see Utah Code Ann., Title 38, Chapter 1a, Pre-construction and Construction Liens, and Utah Code Ann., Title 14, Contractors' Bonds, or Section 63G-6a-1103) related to payment rights the Contractor has on the Property once:

1. Contractor endorses a check in the Payment Amount payable to Contractor or provides valid wire transfer or direct deposit instructions; and
2. The check is paid by the depository institution on which it is drawn or the wired or direct-deposited funds in the Payment Amount are deposited into Contractor's designated account.

This Waiver and Release applies to the final payment for the work, materials, equipment, or combination of work, materials, and equipment furnished by Contractor to the Property or to Owner.

Contractor warrants that it either has already paid, or will promptly use the Payment Amount received to pay in full all of Contractor's laborers, subcontractors, materialmen, and suppliers for all work, materials, equipment, or combination of work, materials, and equipment under the Invoice. Contractor has not assigned any lien or right to perfect a lien against the Property and has the right, power, and authority to execute this Waiver and Release.

_____, a _____

By: _____

Print Name: _____

Title: _____

ATTACHMENT E

CONTRACTOR'S INSURANCE CERTIFICATES

[see attached]

CONFIDENTIAL

SECTION 00 6000

BONDS, CERTIFICATES AND OWNER DOCUMENTS

PART 1 - GENERAL

1.1 SUMMARY

- A. The following documents are incorporated by reference; copies may be obtained from Intermountain Healthcare or the Architect for the cost of reproduction, if necessary. Electronic copies of the Intermountain Healthcare Documents can be obtained by contacting the Intermountain Healthcare Project Manager.
1. Intermountain Healthcare Document – **'Application and Certificate for Payment'**
 2. Intermountain Healthcare Document – **'Application and Certificate for Payment – Continuation Sheet'**
 3. Intermountain Healthcare Document – **'Change Order' (CO)**
 4. Intermountain Healthcare Document – **'Proposed Change Order' (PCO)**
 5. Intermountain Healthcare Document – **'A/E Supplement Instructions' (ASI)**
 6. Intermountain Healthcare Document – **'Proposal Request' (PR)**
 7. Intermountain Healthcare Document – **'Construction Change Directive' (CCD)**
 8. Intermountain Healthcare Document – **'Request for Information' (RFI)**
 9. AIA Document G704 – **'Certificate of Substantial Completion'**
 10. AIA Document G707 – **'Consent of Surety to Final Payment'** (if required)
 11. AIA Document G707A – **'Consent of Surety to Reduction in or Partial Release of Retainage'** (if required)
 12. AIA Document A312 – **'Payment Bond'** (if required)
 13. AIA Document A312 – **'Performance Bond'** (if required)

THIS PAGE LEFT BLANK INTENTIONALLY

SECTION 00 6276.13
EXEMPTION CERTIFICATE

PART 1 - GENERAL

1.1 SUMMARY

- A. Construction materials purchased by or on behalf of **Intermountain Healthcare** *may be* exempt from Utah sales and use taxes. Tax Exempt **Form TC-721** must be used by vendors when purchasing construction materials for **Intermountain Healthcare** projects. A copy of Form TC-721, with the Owner's pertinent tax information, follows this cover page.

THIS PAGE LEFT BLANK INTENTIONALLY



Utah State Tax Commission • 210 N 1950 W • Salt Lake City, UT 84137

Exemption Certificate
(Sales, Use, Tourism and Motor Vehicle Rental Tax)

TC-721
Rev. 11/18

Name of business or institution claiming exemption (purchaser) IHC Health Services, Inc.		Telephone number 801.442.2000	
Street address 36 South State Street, Suite 2200	City Salt Lake City	State UT	ZIP Code 84111
Authorized signature 	Name (please print) Brian Deppe	Title Corporate Tax Director	
Name of Seller or Supplier:		Date	
Sales Tax License Number: 11990296-013-STC		Required for all exemptions marked with an asterisk (*)	

The signer of this certificate MUST check the box showing the basis for which the exemption is being claimed.

DO NOT SEND THIS CERTIFICATE TO THE TAX COMMISSION
Keep it with your records in case of an audit.

For purchases by government, Native American tribes and public schools, use form TC-721G.

Resale or Re-lease

I certify I am a dealer in tangible personal property or services that are for resale or re-lease. If I use or consume any tangible personal property or services I purchase tax free for resale, or if my sales are of food, beverages, dairy products and similar confections dispensed from vending machines (see Rule R865-19S-74), I will report and pay sales tax directly to the Tax Commission on my next sales and use tax return.

Religious or Charitable Institution

I certify the tangible personal property or services purchased will be used or consumed for essential religious or charitable purposes. **This exemption can only be used on purchases totaling \$1,000 or more, unless the sale is pursuant to a contract between the seller and purchaser.**

Construction Materials Purchased for Religious and Charitable Organizations

I certify the construction materials are purchased on behalf of a religious or charitable organization and that they will be installed or converted into real property owned by the religious or charitable organization.

Name of religious or charitable organization: _____

Name of project: _____

Fuels, Gas, Electricity

I certify all natural gas, electricity, coal, coke, and other fuel purchased will be used for industrial use only and not for residential or commercial purposes.

Machinery and Equipment and Normal Operating Repair or Replacement Parts Used in a Manufacturing Facility, Mining Activity, Web Search Portal or Medical Laboratory

I certify the machinery and equipment, normal operating repair or replacement parts, or materials (except office equipment or office supplies) are for use in a Utah manufacturing facility described in SIC Codes 2000-3999 or a NAICS code within NAICS Sector 31-33; in a qualifying scrap recycling operation; in a co-generation facility placed in service on or after May 1, 2006; in the operation of a Web search portal by a new or expanding business described in NAICS Code 518112; in a medical laboratory described in NAICS Code 621511; or in a business described in NAICS 212, Mining (except Oil and Gas), or NAICS 213113, Support Activities for Coal Mining, NAICS 213114, Support Activities for Metal Mining, or NAICS 213115, Support Activities for Nonmetallic Minerals (except Fuels) Mining. For a definition of exempt mining equipment, see Utah Code §59-12-104(14).

Machinery and Equipment and Normal Operating Repair or Replacement Parts Used in an Electronic Payment Service

I certify the machinery and equipment and normal operating repair or replacement parts have an economic life of three years or more and are for use in the operation of an electronic payment service described in NAICS Code 522320.

Machinery or Equipment Used by Payers of Admissions or User Fees

I certify that: (1) the machinery or equipment has an economic life of three or more years and will be used by payers of admissions or user fees (Utah Code §59-12-103(1)(f)); (2) the buyer is in the amusement, gambling or recreation industry (NAICS Subsector 713); and (3) at least 51 percent of the buyer's sales revenue for the previous calendar quarter came from admissions or user fees.

Refinery Machinery, Equipment and Normal Repair or Replacement Parts

I certify the machinery, equipment, normal operating repair parts, catalysts, chemicals, reagents, solutions or supplies are for the use of a refiner who owns, leases, controls or supervises a refinery (see Utah Code §63M-4-701) located in Utah.

Pollution Control Facility

I certify our company has been granted a "Certification of Pollution Control Facilities" as provided for by Utah Code §§19-12-101 - 19-12-305 by either the Air Quality Board or the Water Quality Board. I further certify each item of tangible personal property purchased under this exemption is qualifying.

Municipal Energy

I certify the natural gas or electricity purchased: is for resale; is prohibited from taxation by federal law, the U.S. Constitution, or the Utah Constitution; is for use in compounding or producing taxable energy; is subject to tax under the Motor and Special Fuel Tax Act; is used for a purpose other than as a fuel; is used by an entity exempted by municipal ordinance; or is for use outside a municipality imposing a municipal energy sales and use tax. The normal sales tax exemptions under Utah Code §59-12-104 do not apply to the Municipal Energy Sales and Use Tax.

Short-term Lodging Consumables

I certify the tangible personal property is consumable items purchased by a lodging provider as described in Utah Code §59-12-103(1)(i).

Direct Mail

I certify I will report and pay the sales tax for direct mail purchases on my next Utah *Sales and Use Tax Return*.

Commercial Airlines

I certify the food and beverages purchased are by a commercial airline for in-flight consumption; or, any parts or equipment purchased are for use in aircraft operated by common carriers in interstate or foreign commerce.

Commercials, Films, Audio and Video Tapes

I certify that purchases of commercials, films, prerecorded video tapes, prerecorded audio program tapes or records are for sale or distribution to motion picture exhibitors, or commercial television or radio broadcasters. If I subsequently resell items to any other customer, or use or consume any of these items, I will report any tax liability directly to the Tax Commission.

Alternative Energy

I certify the tangible personal property meets the requirements of Utah Code §59-12-104 and is leased or purchased by or for an alternative energy electricity production facility, a waste energy production facility, or a facility that produces fuel from alternative energy.

Locomotive Fuel

I certify this fuel will be used by a railroad in a locomotive engine.

Research and Development of Alternative Energy Technology

I certify the tangible personal property purchased will be used in research and development of alternative energy technology.

Life Science Research and Development Facility

I certify that: (1) the machinery, equipment and normal operating repair or replacement parts purchased have an economic life of three or more years for use in performing qualified research in Utah; or (2) construction materials purchased are for use in the construction of a new or expanding life science research and development facility in Utah.

Mailing Lists

I certify the printed mailing lists or electronic databases are used to send printed material that is delivered by U.S. mail or other delivery service to a mass audience where the cost of the printed material is not billed directly to the recipients.

Semiconductor Fabricating, Processing or Research and Development Material

I certify the fabricating, processing, or research and development materials purchased are for use in research or development, manufacturing, or fabricating of semiconductors.

Telecommunications Equipment, Machinery or Software

I certify these purchases or leases of equipment, machinery, or software, by or on behalf of a telephone service provider, have a useful economic life of one or more years and will be used to enable or facilitate telecommunications; to provide 911 service; to maintain or repair telecommunications equipment; to switch or route telecommunications service; or for sending, receiving, or transporting telecommunications service.

Ski Resort

I certify the snow-making equipment, ski slope grooming equipment or passenger rope-ways purchased are to be paid directly with funds from the ski resort noted on the front of this form.

Aircraft Maintenance, Repair and Overhaul Provider

I certify these sales are to or by an aircraft maintenance, repair and overhaul provider for the use in the maintenance, repair, overhaul or refurbishment in Utah of a fixed-wing, turbine-powered aircraft that is registered or licensed in a state or country outside Utah.

Leasebacks

I certify the tangible personal property leased satisfies the following conditions: (1) the property is part of a sale-leaseback transaction; (2) sales or use tax was paid on the initial purchase of the property; and, (3) the leased property will be capitalized and the lease payments will be accounted for as payments made under a financing arrangement.

Film, Television, Radio

I certify that purchases, leases or rentals of machinery or equipment will be used by a motion picture or video production company for the production of media for commercial distribution.

Prosthetic Devices

I certify the prosthetic device(s) is prescribed by a licensed physician for human use to replace a missing body part, to prevent or correct a physical deformity, or support a weak body part. This is also exempt if purchased by a hospital or medical facility. (Sales of corrective eyeglasses and contact lenses are taxable.)

Out-of-State Construction Materials

I certify this tangible personal property, of which I am taking possession in Utah, will be taken out-of-state and will become part of real property located in a state that does not have sales tax, is taxed at a lower rate, or does not allow credit for tax paid to Utah. I will report the tax on my next Utah return at the lower of the Utah rate where the tangible personal property was purchased or the rate of the location where the tangible personal property is converted to real property in the other state if the other state allows a credit for tax paid to Utah.

Agricultural Producer

I certify the items purchased will be used primarily and directly in a commercial farming operation and qualify for the Utah sales and use tax exemption. **This exemption does not apply to vehicles required to be registered.**

Tourism/Motor Vehicle Rental

I certify the motor vehicle being leased or rented will be temporarily used to replace a motor vehicle that is being repaired pursuant to a repair or an insurance agreement; the lease will exceed 30 days; the motor vehicle being leased or rented is registered for a gross laden weight of 12,001 pounds or more; or, the motor vehicle is being rented or leased as a personal household goods moving van. This exemption applies only to the tourism tax (up to 7 percent) and the short-term motor vehicle rental tax (Transportation Corridor Funding – 2.5 percent) – not to the state, local, transit, zoo, hospital, highways, county option or resort sales tax.

Textbooks for Higher Education

I certify that textbooks purchased are required for a higher education course, for which I am enrolled at an institution of higher education, and qualify for this exemption. An institution of higher education means: the University of Utah, Utah State University, Utah State University Eastern, Weber State University, Southern Utah University, Snow College, Dixie State University, Utah Valley University, Salt Lake Community College, or the Utah System of Technical Colleges.

* Purchaser must provide sales tax license number in the header on page 1.

NOTE TO PURCHASER: You must notify the seller of cancellation, modification, or limitation of the exemption you have claimed.

Questions? Email taxmaster@utah.gov, or call 801-297-2200 or 1-800-662-4335.

SECTION 00 7000
GENERAL CONDITIONS

PART 1 - GENERAL

1.1 SUMMARY

- A. **INTERMOUNTAIN HEALTHCARE GENERAL CONDITIONS of the Contract for Construction** follows this page. Where any part of the General Conditions is modified, the unaltered provisions shall remain in effect. An electronic copy may be obtained from Intermountain Healthcare's Project Manager.

THIS PAGE LEFT BLANK INTENTIONALLY

GENERAL CONDITIONS

1. General Provisions
2. Intermountain
3. A/E
4. Contractor
5. Subcontractors
6. Protection of Persons and Property
7. Modifications, Request for Information, Proposed Change Orders, and Claims Process
8. Payments and Completion
9. Tests and Inspections, Substantial and Final Completion, Uncovering, Correction of Work, and Guaranty Period
10. Insurance and Bonds
11. Miscellaneous Provisions
12. Termination or Suspension of the Contract

1. GENERAL PROVISIONS.

1.1 Basic Definitions.

“Adverse Weather”: Weather conditions that are seasonably abnormal and could not reasonably have been anticipated.

“A/E”: Generally, the licensed architect (or architecture firm) or engineer (or engineering firm) for the Project. For Contracts where the design professional is an interior designer, landscape subconsultant or other design professional, “A/E” will be deemed to refer to that design professional. If the type of design professional is not subject to professional licensure requirements, the professional must meet the prevailing standards in the State in which the Project is located for the applicable practice. When Intermountain elects not to engage an A/E for a Project, Intermountain will be considered the A/E for the Project.

“A/E’s Agreement”: Unless the context requires otherwise, the agreement executed by A/E and Intermountain for the Project.

“Addenda”: Written or graphic instruments issued before the opening of Bids, which clarify, correct or change the bidding documents or the Contract Documents.

“ASI”: A Supplemental Instruction issued by A/E to Contractor, which may result in clarifications or minor changes in the Work, but which does not affect the Contract Time or the Contract Sum.

“Bid”: The offer of the bidder submitted on the prescribed form setting forth the proposed stipulated sum for the Work to be performed.

“Bonds”: The bid bond, payment and performance bonds, and other instruments of security.

“Change Order”: A written instrument signed by Intermountain and Contractor, stating their agreement for changes to the Contract as specified on the required Intermountain change order form.

“Claim”: A dispute, demand, assertion or other matter arising in connection with the Contract or the Project submitted by Contractor or a Subcontractor at any tier in accordance with these General Conditions. A requested amendment, requested Change Order, or a Construction Change Directive (CCD) is not a Claim unless agreement cannot be reached in accordance with the procedures in these General Conditions.

“Construction Change Directive” or **“CCD”**: A written order signed by Intermountain, directing a change in the Work, and stating a proposed basis for adjustment, if any, in the Contract Sum or Contract Time, or both. Intermountain may by Construction Change Directive, without invalidating the Contract, order changes in the Work within the general scope of the Contract consisting of additions, deletions or other revisions; even if it may impact the Contract Sum and Contract Time.

“Contract”: The Contract Documents form the Contract for Construction.

“Contract Documents”: The documents identified as such in the Contractor’s Agreement.

“Contract Sum”: The amount stated in the Contractor’s Agreement payable by Intermountain to Contractor for performance of the Work under the Contract Documents.

“Contract Time”: The Contract Time means the period of time for Contractor’s Substantial Completion of the Work to be established as set forth in the Contractor’s Agreement.

“Contractor”: The person or entity identified as the “Contractor” in the Contractor’s Agreement.

“Contractor’s Agreement”: The “Contractor’s Agreement” means the Construction Manager/General Contractor Agreement or the General Contractor Agreement for a Stipulated Sum, as applicable, executed by Contractor and Intermountain for the Project.

“Contractor’s Direct Costs”: Actual costs incurred by the Contractor for labor, materials, equipment, insurance, bonds, Subcontractors and on-site supervision. They do not include labor costs for project managers or other off-site administration.

“Day” or “Days”: Calendar day unless otherwise specified.

“Defective”: Work that does not conform to the Contract Documents or does not meet the requirements of any inspection, referenced standard, code, test or approval referred to in the Contract Documents or by applicable law, or has been damaged.

“Director”: Intermountain’s Executive Director of Design & Construction unless the context requires otherwise. Director may include a designee selected by the Director for a specific function.

“Drawings”: The construction drawings identified in the Contractor’s Agreement.

“Intermountain”: IHC Health Services, Inc., operating through its Department of Facility Design and Construction. Unless the context requires otherwise, Intermountain is the “Owner” as that term is commonly referred to in the construction industry.

“Intermountain Representative” or “Owner’s Representative”: The person identified as such in the Contract Documents.

“Inspection” (or any derivative): A review of the Project, including but not limited to a visual review of the Work to ascertain if the Work is in accordance with the Contract Documents, including all applicable building codes and construction standards.

“Invitation to Bid”: Intermountain’s solicitation or request to a contractor to provide a Bid.

“Modification”: (1) Change Order, (2) Construction Change Directive, or (3) ASI.

“Notice to Proceed”: A document prepared by Intermountain authorizing Contractor to commence Work on the Project. It is deemed issued upon delivery to Contractor or upon being sent by Intermountain to the address for Contractor’s specified in the Bid or Proposal.

“Partial Use”: Placing a portion of the Work in service for the purpose for which it is intended (or a related purpose) before reaching Substantial Completion for all the Work. Partial Use does not constitute “substantial completion.”

“Product Data”: Illustrations, standard schedules, performance charts, instructions, brochures, diagrams and other information furnished by Contractor to illustrate materials or equipment for some portion of the Work.

“Project”: Generally identified and defined in the Contractor’s Agreement and Contract Documents. It includes all of the Work to be performed under the Contract Documents.

“Project Manual” (for construction): The volume of assembled Specifications for the Work, which may include the bidding/proposal requirements, sample forms, and General or Supplementary Conditions of the Contract.

“Proposal”: A/E’s or Contractor’s response to Intermountain’s Request for Proposal.

“Proposal Request” or **“PR”**: A written request submitted to Contractor for a proposal to resolve an issue as part of the Change Order or Contract Modification process.

“Proposed Change Order” or **“PCO”**: An informal request by Contractor to Intermountain Representative to commence the Contract Modification Process. It will not be considered a “Claim.” The PCO may be related to any potential or actual delay, disruption, unforeseen condition or materials or any other matter for which Contractor intends to seek additional monies or time.

“Request for Information” or **“RFI”**: A request by Contractor to A/E for information, direction or clarification regarding the Contract Documents, plans or specifications.

“Request for Proposal” or **“RFP”**: Intermountain’s solicitation for Contractor Proposals.

“Sales Tax” and/or **“Use Tax”**: Unless the context requires otherwise, the sales tax or use tax collected or to be collected by any Federal or State Tax Commission as well as by any special district, local government or political subdivision.

“Samples”: Physical examples, which illustrate materials, equipment or workmanship and establish standards by which the Work will be judged.

“Shop Drawings”: Drawings, diagrams, schedules and other data specially prepared for the Work by Contractor or a Subcontractor, Sub-subcontractor, manufacturer, supplier or distributor to illustrate some portion of the Work.

“Specifications”: The portion of the Contract Documents consisting of the written requirements for materials, equipment, construction systems, standards, installation and workmanship for the Work, and for performance of related systems and services.

“Subcontractor”: Any person or entity that has a direct contract with Contractor, including any trade contractor or specialty contractor, and/or with any other Subcontractor at any tier to provide labor or materials for the Work.

“Subcontractor’s Direct Costs”: Actual costs incurred by a Subcontractor for labor, materials, equipment, insurance, bonds, lower-tier Subcontractors and supervision.

“Substantial Completion”: Completion of the Work or designated portion thereof in accordance with the Contract Documents to a point sufficient to allow Intermountain to occupy and use the Work for its intended purposes, including without limitation all systems shall be fully functional and operate as designed, and the A/E’s certification that Contractor has achieved Substantial Completion of the Work. The date of Substantial Completion is the date certified as such by the A/E in accordance with the Contract Documents.

“Work”: All labor, materials, tools, equipment, construction and services required by the Contract Documents.

1.2 Correlation and Intent of Contract Documents.

- 1.2.1 The intent of the Contract Documents is to require Contractor to provide all labor, materials, equipment, construction, and services necessary for the proper execution and completion of the Work. The Contract Documents are complementary and what is required by any one will be as binding as if required by all. Contractor will perform the Work in accordance with the requirements expressly set forth in or reasonably inferable from the Contract Documents.
- 1.2.2 The organization of the Contract Documents is not intended to control Contractor in dividing the Work among Subcontractors or to establish the extent of the Work to be performed by any trade.
- 1.2.3 Words used in the Contract Documents that have well known technical or trade meanings are used therein in accordance with such recognized meanings.

1.2.4 In the interest of brevity, the Contract Documents may omit modifying words such as "all" and "any" and articles such as "the" and "an," but the fact that a modifier or an article is absent from one statement and appears in another is not intended to affect the interpretation of either statement.

1.3 Ownership and Use of Contract Documents. The Drawings, the Project Manual, and copies thereof are the property of Intermountain. Contractor will not use these documents on any other project. Contractor may retain one copy of the Drawings and the Project Manual as a contract record set and will return or destroy all remaining copies following final completion of the Work.

1.4 Public Statements Regarding Project. Contractor will not make any statements or provide any information to the media about the Project without the prior written consent of Intermountain. If Contractor receives any requests for information from media, Contractor will refer such requests to Intermountain.

1.5 Ownership and Use of Renderings and Photographs. Renderings representing the Work are the property of Intermountain. All photographs of the Work, whether taken during performance of the Work or at completion, are the property of Intermountain. Intermountain reserves all rights including copyrights to renderings and photographs of the Work. No renderings or photographs will be used or distributed without written consent of Intermountain.

1.6 Confidentiality / Property Rights.

1.6.1 All Drawings, Specifications and other documents prepared by A/E are and will remain the property of Intermountain, and Intermountain will retain all common law, statutory and other reserved rights with respect thereto. These documents were prepared and are intended for use as an integrated set for the Project which is the subject of the Contractor's Agreement and constitute works made for hire. Contractor will not modify or use Contract Documents on any other project without the prior written consent of Intermountain. Intermountain may withhold its consent in its absolute discretion. Any non-permissive use or modification, by Contractor, Contractor's Subcontractors at any tier or anyone for whose acts Contractor is liable, will be at Contractor's sole risk. Contractor will hold harmless and indemnify Intermountain from and against any and all claims, actions, suits, costs, damages, loss, expenses and attorney fees arising out of such non-permissive use or modification by Contractor. Contractor and Subcontractors are granted a limited license to use and reproduce applicable portions of the Drawings, Specifications and other documents prepared by A/E or Intermountain appropriate to and for use in the execution of their Work under the Contract Documents. All copies made under this license will bear the statutory copyright notice, if any, shown on the Drawings, Specifications and other documents prepared by A/E or Intermountain. Submittals or distributions necessary to meet official regulatory requirements or for other purposes relating to completion of the Project are not to be construed as a publication in derogation of Intermountain's copyright or other reserved rights.

1.6.2 In addition, Contractor will ensure that Contractor, Subcontractors, and the employees, agents and representatives of Contractor and its Subcontractors maintain in strict confidence, and will use and disclose only as authorized by Intermountain all Confidential Information of Intermountain that Contractor receives in connection with the performance of the Contract. Notwithstanding the foregoing, Contractor may use and disclose any information to the extent required by an order of any court or authority having jurisdiction, but only after it has notified Intermountain and Intermountain has had an opportunity to obtain reasonable protection for such information in connection with such disclosure. For purposes of the Contract, "Confidential Information" means:

1.6.3 The name or address of any affiliate, customer or contractor of Intermountain or any information concerning the transactions of any such person with Intermountain;

1.6.4 Any information relating to contracts, agreements, business plans, budgets or other financial information of Intermountain to the extent such information has not been made available to the public by Intermountain; and

- 1.6.5 Any other information that is marked or noted as confidential by Intermountain at the time of its disclosure.

1.7 Comply with Intellectual Property Rights of Others. Contractor represents and warrants that no Work (with its means, methods, goods, and services attendant thereto), provided to Intermountain will infringe or violate any right of any third party and that Intermountain may use and exploit such Work, means, methods, goods, and services without liability or obligation to any person or entity (specifically and without limitation, such Work, means, methods, goods, and services will not violate rights under any patent, copyright, trademark, or other intellectual property right or application for the same).

2. INTERMOUNTAIN.

2.1 Information and Services Required of Intermountain.

- 2.1.1 Intermountain Representative. Intermountain will designate an Intermountain Representative authorized to act in Intermountain's behalf with respect to the Project. Intermountain or such authorized representative will furnish to Contractor information or services Intermountain is required to furnish under the Contract Documents within a reasonable time in order to avoid a delay in the orderly and sequential progress of the Work.
- 2.1.2 Specialists and Inspectors. Intermountain reserves the right (but without obligation to provide building inspection services. This may include 'routine' and 'special' inspections. Intermountain may assign an inspector or specialist to note deviations from, or necessary adjustments to, the Contract Documents or to report deficiencies or defects in the Work. The inspector or specialist's activities in no way relieve Contractor of the responsibilities set forth in the Contract Documents.
- 2.1.3 Inspections. Intermountain and its representatives will have the right to inspect any portion of the Work wherever located at any time.
- 2.1.4 Surveys and Legal Description. Intermountain will furnish surveys describing the property lines and benchmarks for grading. Contractor will review this information, including the surveys and any provided geotechnical studies, and compare such information with observable physical conditions and the Contract Documents.
- 2.1.5 Prompt Information and Services. Upon receipt of a written request from Contractor, Intermountain will furnish information or services under Intermountain's control with reasonable promptness to avoid delay in the orderly progress of the Work.
- 2.1.6 Copies of Drawings and Project Manuals (for Construction). Unless otherwise provided in the Contract Documents, Contractor will be furnished electronic copies of Drawings and Project Manuals for Contractor's use in connection with the execution of the Work for the Project. Contractor will be responsible for making any further needed copies of the Construction Documents, subject to the copyright requirements.

2.2 Construction by Intermountain or By Separate Contractors.

- 2.2.1 Intermountain's Right to Perform Construction and to Award Separate Contracts.
- a. *In General.* Intermountain reserves the right to perform construction or operations related to the Project with Intermountain's own forces, and to award separate contracts related to the Project or other construction or operations on the site.
 - b. *Coordination and Revisions.* Intermountain will provide for coordination of the activities of Intermountain's own forces and of each separate contractor with the Work of Contractor, who will cooperate with them. Contractor will promptly notify in writing if any such independent action will in any way compromise Contractor's ability to meet Contractor's responsibilities under the Contract. Contractor will participate with other separate contractors and Intermountain in reviewing their construction schedules when directed to do so. Contractor will make any revisions to the construction schedule and Contract Sum deemed necessary after a

joint review and agreement by Intermountain. The construction schedules will then constitute the schedules to be used by Contractor, separate contractors and Intermountain until subsequently revised.

2.2.2 Mutual Responsibility.

- a. *Contractor Coordination.* Contractor will afford Intermountain and separate contractor(s) a reasonable opportunity for delivery and storage of their materials and equipment and performance of their activities and will connect and coordinate Contractor's construction and operations with theirs where applicable.
- b. *Reporting Problems to Intermountain.* If part of Contractor's Work depends on work by Intermountain or a separate contractor, Contractor will, before proceeding with that portion of the Work, inspect and promptly report in writing to Intermountain apparent discrepancies or defects in workmanship that would render it unsuitable for proper execution, performance, or results. Failure of Contractor to so inspect and make this report will constitute an acceptance and acknowledgment that Intermountain's or separate contractors completed or partially completed construction is fit and proper to receive Contractor's Work, except as to defects in workmanship not then reasonably discoverable.
- c. *Costs.* Costs caused by delays or by improperly timed activities or Defective construction will be borne by the responsible party in accordance with the procedures and provisions of the Contract Documents.
- d. *Contractor Remedial Work.* Contractor will promptly remedy damage caused by Contractor or any Subcontractor to completed or partially completed work of Intermountain or of separate contractors or to the property of Intermountain or separate contractors and subcontractors.
- e. *Intermountain's Right to Clean Up.* If a dispute arises among Contractor and separate contractors as to the responsibility under their separate contracts for maintaining the Project free from waste materials and rubbish, Intermountain may clean the Project, allocate the cost among those responsible as Intermountain and A/E determine to be just, and withhold such cost from any amounts due or to become due to Contractor.

3. A/E.

3.1 A/E's Administration of the Contract.

- 3.1.1 In General. A/E assists Intermountain with the administration of the Contract as described in the Contract Documents.
- 3.1.2 Site Visits. Site visits or inspections by A/E, Intermountain or any Intermountain representative will in no way limit or affect Contractor's responsibility to comply with all the requirements and the overall design concept of the Contract Documents as well as all applicable laws, statutes, ordinances, resolutions, codes, rules, regulations, orders and decrees. A/E will promptly submit to Intermountain a written report subsequent to each site visit.
- 3.1.3 Communications Facilitating Contract Administration. Except as authorized by Intermountain or as otherwise provided in the Contract Documents, including these General Conditions, A/E and Contractor will communicate through the Intermountain Representative on issues regarding the timing of the Work, cost of the Work, and scope of the Work. Contractor will comply with communication policies agreed upon at any pre-construction meeting with Intermountain. Communications by and with A/E sub-consultants will be through A/E. Communications by and with Subcontractors will be through Contractor. Communications by and with separate contractors will be through Intermountain.
- 3.1.4 A/E May Reject Work, Order Inspection, Tests. A/E will have the authority to reject Work which, based upon A/E's knowledge or what may be reasonably inferred from A/E's site observations and review of data, does not conform to the Contract Documents or is damaged or rendered unsuitable.

Whenever A/E considers it necessary or advisable for implementation of the intent of the Contract Documents, A/E will have the authority to require additional inspections or testing of the Work in accordance with the provisions of the Contract Documents, whether or not such Work is fabricated, installed or completed. However, neither this authority of A/E nor a decision made in good faith either to exercise or not to exercise such authority will give rise to a duty or responsibility of A/E to Contractor, Subcontractors, their agents or employees or other persons performing portions of the Work, including separate contractors.

3.1.5 A/E Review Contractor's Submittals.

- a. Contractor will submit shop drawings, product data, and samples and other submittals required by the Contract Documents to A/E as required by the approved submittal schedule.
- b. A/E will review and approve or take other appropriate action upon Contractor's submittals such as Shop Drawings, Product Data and Samples, but only for the purpose of checking for conformance with the information and design concepts expressed in the Contract Documents. A/E action taken on a submittal will not constitute a Modification of the Contract.
- c. A/E's action will be taken no later than fifteen (15) Days following A/E's receipt of the submittal, unless agreed to otherwise by Contractor and Intermountain.
- d. Review of such submittals is not conducted for the purpose of determining the accuracy and completeness of other details such as dimensions and quantities or for substantiating instructions for installation or performance of equipment or systems, all of which remain the responsibility of Contractor as required by the Contract Documents.
- e. A/E's review of Contractor's submittals will not relieve Contractor of the obligations under the Contract Documents.
- f. A/E's review will not constitute approval of safety precautions or, unless otherwise specifically stated by A/E, of any construction means, methods, techniques, sequences or procedures.
- g. A/E's approval of a specific item will not indicate approval of an assembly of which the item is a component.
- h. When professional certification of performance characteristics of materials, systems or equipment is required by the Contract Documents, A/E will be entitled to rely upon such certifications to establish that the materials systems or equipment will meet the performance criteria required by the Contract Documents.

3.2 Ownership and Use of A/E's Drawings, Specifications and Other Documents. All Drawings, Specifications and other documents prepared by A/E are and will remain the property of Intermountain, and Intermountain will retain all common law, statutory and other reserved rights with respect thereto. These documents were prepared and are intended for use as an integrated set for the Project which is the subject of the Contractor's Agreement and constitute works made for hire. Contractor will not modify or use Contract Documents on any other project without the prior written consent of Intermountain. Intermountain may withhold its consent in its absolute discretion. Any non-permissive use or modification, by Contractor, Contractor's Subcontractors at any tier or anyone for whose acts Contractor is liable, will be at Contractor's sole risk. Contractor will hold harmless and indemnify Intermountain from and against any and all claims, actions, suits, costs, damages, loss, expenses and attorney fees arising out of such non-permissive use or modification by Contractor. Contractor and Subcontractors are granted a limited license to use and reproduce applicable portions of the Drawings, Specifications and other documents prepared by A/E or Intermountain appropriate to and for use in the execution of their Work under the Contract Documents. All copies made under this license will bear the statutory copyright notice, if any, shown on the Drawings, Specifications and other documents prepared by A/E or Intermountain. Submittals or distributions necessary to meet official regulatory requirements or for other purposes relating to completion of the Project are not to be construed as a publication in derogation of Intermountain's copyright or other reserved rights.

4. CONTRACTOR. Contractor's duties include the professional services of a business, administrative and management consultant to Intermountain; including all budget, scheduling, quality, safety and all other services related to assuring compliance with the Contract Documents.

4.1 Review of Contract Documents and Field Conditions by Contractor. By executing the Contractor's Agreement, Contractor represents that it has visited the Project site, familiarized itself with the local conditions under which the Work is to be performed, and correlated its own observations with the requirements of the Contract Documents.

4.1.1 Reviewing Contract Documents, Information, Reporting Errors, Inconsistencies or Omissions.

- a. Contractor will carefully study and compare the Contract Documents with each other and with information available relating to the Project or furnished by Intermountain before commencing and during performance of each portion of the Work and will at once report to Intermountain and A/E any errors, inconsistencies or omissions it discovers. If Contractor performs any construction activity without such notice to Intermountain and A/E and before the resolution of the error, inconsistency or omission, Contractor will assume responsibility for such performance and will bear the attributable costs for correction.
- b. Contractor will give Intermountain and/or A/E notice of any additional drawings, specifications, or instructions required to define the Work in greater detail, or to permit the proper progress of the Work, sufficiently in advance of the need for information so as not to delay the Work.
- c. It is not Contractor's responsibility to ascertain that the Contract Documents are in accordance with requirements of applicable laws, statutes, ordinances, building codes, rules and regulations. However, if Contractor observes that portions of the Contract Documents are at variance with those requirements, Contractor will immediately notify Intermountain and/or A/E in writing. Contractor will not proceed unless Intermountain and/or A/E effects Modifications to the Contract Documents required for compliance with such requirements. Contractor will be fully responsible for any work knowingly performed contrary to such requirements and will fully indemnify Intermountain against loss and bear all costs and penalties arising therefrom.

4.1.2 Field Conditions.

- a. Contractor will take field measurements and verify field conditions and will carefully compare such field measurements and conditions and other information known to Contractor, or information which a Contractor of ordinary skill and expertise for the type of Work involved would have known, before commencing activities. Errors, inconsistencies or omissions discovered will be reported to Intermountain and A/E at once. If Contractor performs any construction activity without such notice to Intermountain and A/E and before the resolution of the error, inconsistency or omission, Contractor will not be entitled to any compensation for additional costs attributable to correction or otherwise to Contractor resulting from field measurements or conditions different from those anticipated by Contractor which would have been avoided had Contractor taken field measurements and verified field conditions before ordering the materials or commencing construction activities.
- b. If site conditions indicated in the Contract Documents or other information provided by Intermountain or A/E to Contractor differ materially from those Contractor encounters in performance of the Work, Contractor will immediately notify Intermountain and/or A/E in writing of such differing site conditions.

4.1.3 Perform in Accordance with Contract Documents and Submittals. Contractor will perform the Work in accordance with the Contract Documents and submittals approved in accordance with the Contract Documents. Should Contractor or any of its Subcontractors become aware of any question regarding the meaning or intent of any part of the Contract Documents before commencing that portion of the Work about which there is a question, Contractor will request an interpretation or clarification from Intermountain and/or A/E before proceeding. Contractor proceeds at its own risk if it proceeds with

the Work without first making such a request and receiving an interpretation or clarification from Intermountain and/or A/E.

- 4.1.4 Performance to Produce the Complete System and Intended Results. Performance by Contractor will be required to the extent consistent with the Contract Documents and reasonably inferable from the Contract Documents as being necessary to allow the system to function within its intended use.
- 4.1.5 Intent and Hierarchy. The Contract Documents should be read as a whole and wherever possible, the provisions should be construed in order that all provisions are operable. The intent of the Contract Documents is to include all items necessary for the proper execution and completion of the Work by Contractor. The Contract Documents are complimentary, and what is required by one Document or provisions thereof will be as binding as if required by all the Documents or provisions thereof. In case of an irreconcilable conflict between provisions within a Contract Document or between Contract Documents, the following priorities will govern as listed below:
- a. A particular Modification will govern over all Contract Document provisions or Modifications issued before this particular Modification.
 - b. A particular Addendum will govern over all other Contract Document provisions issued before this particular Addendum. Subsequent Addenda will govern over all prior Addenda.
 - c. The Supplementary Conditions will govern over the General Conditions.
 - d. The Agreement and these General Conditions will govern over all other Contract Documents except for the Supplementary Conditions, Addenda, Modifications.
 - e. The drawings and specifications will not govern over any of the documents listed above. The specifications take precedence over the drawings.
 - f. Within the Drawings, larger scale drawings take precedence over smaller scale drawings, figured dimensions over scaled dimensions, and noted materials over graphic indications.
 - g. In case of a conflict or ambiguity within the same level of hierarchy of described documents, Intermountain reserves the right to select the most stringent requirement unless the preponderance of the contract indicates the less stringent requirement.
- 4.1.6 Dividing Work and Contractor Representation. Organization of the specifications into divisions, sections and articles, and arrangement of Drawings, will not control Contractor in dividing the Work among Subcontractors or in establishing the extent of Work to be performed by any trade. Contractor represents that the Subcontractors, Sub-subcontractors, manufacturers and suppliers engaged or to be engaged by it are and will be familiar with the requirements for performance by them of their obligations. Where the Contract Documents require Contractor to provide professional services for architecture or engineering, Contractor will cause such services to be performed by appropriately licensed professionals.
- 4.1.7 Planning and Priority. Contractor will plan and schedule its work to facilitate the Project and will maintain a work schedule to place proper priority to sequence work to complete the project timely.
- 4.1.8 Prior to Contractor taking control over any area in any existing facility or on any project site, Contractor will provide prior written notice to Intermountain with sufficient time (no less than 30 Days) to allow Intermountain's Asset Recovery Team to remove, secure, and otherwise address existing materials, furniture, fixtures, equipment, and other assets located thereon.

4.2 Supervision and Construction Procedures.

- 4.2.1 Supervision and Control.
- a. Contractor will utilize its best skill, efforts, and judgment to provide efficient business administration and supervision, to furnish at all times an adequate supply of workers and materials, and to perform the Work in an expeditious and economical manner consistent with

the interests of Intermountain.

- b. Contractor will supervise and direct the Work. Contractor will be solely responsible for all construction means, methods, techniques, sequences and procedures and for coordinating all portions of the Work.
 - c. All loss, damage, liability, or cost of correcting Defective work arising from the use of any construction means, methods, techniques, sequences or procedures will be borne by Contractor, notwithstanding that such construction means, methods, techniques, sequences or procedures are referred to, indicated or implied by the Contract Documents, unless Contractor has given timely notice to Intermountain and A/E in writing that such means, methods, techniques, sequences or procedures are not safe or suitable, and Intermountain has then instructed Contractor in writing to proceed at Intermountain's risk.
- 4.2.2 Responsibility. Contractor will be responsible to Intermountain for acts and omissions of Contractor's employees, Subcontractors, and their agents and employees, and other persons performing portions of the Work under a contract with Contractor or on behalf of Contractor.
- 4.2.3 Not Relieved of Obligations. Contractor will not be relieved of obligations to perform the Work in accordance with the Contract Documents either by activities or duties of Intermountain or its agents in Intermountain's administration of the Contract, or by tests, inspections or approvals by Intermountain, A/E, or their consultants, or as required or performed by persons other than Contractor or for those that Contractor is liable.
- 4.2.4 Inspections and Approvals.
- a. Contractor is responsible for requesting inspections for various stages and portions of the Work required under the Contract Documents in a timely manner.
 - b. Contractor will be responsible for inspection of portions of the Work already completed to determine that such portions are in proper condition to receive subsequent portions of the Work.
 - c. If any of the Work is required to be inspected or approved by the terms of the Contract Documents by any public authority, Contractor will timely request such inspection or approval to be performed in accordance with Article 9. Except as provided in Article 9, work will not proceed without any required inspection and the associated authorization to proceed. Contractor will promptly notify Intermountain if the inspector fails to appear at the site.
- 4.3 Labor and Materials.**
- 4.3.1 Payment by Contractor. Except to the extent it is otherwise stated in the Contract Documents, Contractor will provide and pay for labor, materials, equipment, tools, construction equipment and machinery, water, heat, utilities, transportation, and other facilities, supplies, consumables and services necessary for the proper execution and completion of the Work, whether temporary or permanent and whether or not incorporated or to be incorporated in the Work.
- 4.3.2 Discipline and Competence. Contractor will enforce strict discipline and good order among Contractor's employees, Subcontractors, agents, representatives and other persons performing under the Contract Documents. Contractor will not permit employment of unfit persons or persons not skilled in tasks assigned to them.
- 4.3.3 Phased Construction / Accommodations for Facilities to Stay Operational. Contractor and all Subcontractors will direct and perform the Work, phase and coordinate all construction and related activities and timing, in a manner to preserve ongoing patient care and safety to all and to accommodate in every instance Intermountain's ongoing business operations such that facilities stay fully functioning and operational at all times.
- 4.4 Taxes and Other Payments to Government.** Intermountain will pay all taxes and assessments on the real property comprising the Project site. Contractor will pay all applicable sales, consumer, use, payroll, workers

compensation, unemployment, old age pension, surtax, and employment-related and similar taxes related to performance of the Work or portions thereof provided by Contractor which are legally enacted when bids are received or negotiations concluded, whether or not yet effective or merely scheduled to go into effect, and will comply with the laws and regulations regarding the payment of Sales and/or Use Tax and any applicable exemptions.

4.5 Permits, Fees, Notices, Labor and Materials.

4.5.1 Permits and Fees.

- a. Intermountain will obtain and pay for all zoning and use permits and permanent easements necessary for completion of the Work.
- b. Contractor will obtain and pay for the building permit, and all other permits, governmental fees, licenses and inspections necessary for the proper execution and completion of the Work.
- c. Contractor will secure any certificates of inspection and of occupancy required by authorities having jurisdiction over the Work. Contractor will deliver these certificates to A/E before issuance of the Certificate of Substantial Completion by A/E.

4.5.2 Compliance with Law, Public Authorities, Notices. Contractor will comply with all applicable federal, state and local laws, statutes, ordinances, resolutions, rules, regulations, codes, and lawful orders of public authorities.

4.5.3 Correlation of Contract Documents and Enactments.

- a. It is not Contractor's responsibility to ascertain that the Contract Documents are in accordance with applicable laws, statutes, ordinances, resolutions, building codes, and rules and regulations. Notwithstanding this, if Contractor observes, or if such is readily observable to a Contractor of ordinary skill and expertise for the type of Work involved, that a portion of the Contract Documents is at variance therewith, Contractor will promptly notify A/E and Intermountain in writing, and necessary changes will be accomplished by appropriate Modification.
- b. Contractor will coordinate and supervise the work performed by Subcontractors so that the Work is carried out without conflict between trades and so that no trade, at any time, causes delay to the general progress of the Work. Contractor and all Subcontractors will at all times afford each trade, any separate contractor, or Intermountain, reasonable opportunity for the installation of Work and the storage of materials.
- c. Contractor is fully responsible for the Project and all materials and work connected therewith until Intermountain has accepted the Work in writing. Contractor will replace or repair at its own expense any materials or work damaged or stolen, regardless of whether it has received payment for such work or materials from Intermountain.
- d. Contractor will remedy all damage or loss to any property caused in whole or in part by Contractor, any Subcontractor, or by anyone for whose acts any of them may be liable.
- e. Intermountain may elect to purchase materials required for the Work. In that event, Contractor will comply with the procedures set forth in the Contract Documents relating to such materials.

4.5.4 Failure to Give Notice. If Contractor, or any Subcontractor thereof performs Work without complying with the requirements of this Article 4.5 hereinabove, Contractor will assume appropriate responsibility for such Work and will bear the appropriate amount of the attributable costs.

4.5.5 Intermountain-Purchased Materials and Equipment.

- a. In addition to Contractor's other obligations with respect to separate Intermountain provided work or materials, Contractor's obligations and duties with respect to Intermountain-purchased materials, equipment, and work include:

- (i) Scheduling: The Contractor shall furnish Intermountain with a schedule of dates on which the Contractor requires delivery of Intermountain-purchased materials. Intermountain will arrange for the materials to be delivered to the construction site or picked up by Contractor on or before the specified dates. If delivery or pick up dates are changed, rescheduled, or otherwise varied from the original schedule, the Contractor shall notify Intermountain in writing of delivery or pick up date rescheduling and the Contractor shall coordinate the delivery or pick up of the Intermountain-purchased materials or equipment directly with the supplier.
- (ii) Equipment / Vehicles: If Intermountain buys equipment or vehicles for Contractor's use on the Project, Contractor will (in addition to all other obligations herein relative to such equipment or vehicles) be fully and solely responsible for such equipment and vehicles as well as the use and use consequences thereof for any and all purposes (including without limitation to protect, secure, inspect, upkeep and make repairs, and insure such equipment and vehicles as well as to monitor, guide, direct, oversee, protect, and control the use and use consequences of such equipment and vehicles) until completion of the Project and Contractor's return of such equipment and/or vehicles to Intermountain.
- (iii) Pre-Installation Inspection: The Contractor shall be responsible for receiving, inspecting and storing all Intermountain- purchased materials and equipment until the materials or equipment are needed for installation or use by the Contractor. Regardless of any inspection performed by Intermountain of the Intermountain-purchased materials or equipment, the Contractor shall be responsible for inspecting the Intermountain-purchased materials and equipment to determine suitability, quality and conformance with specifications before installation or use or at such other times as the Contractor may desire in order to avoid interruptions and delays in the progress of the Project. The Contractor shall reject any material which does not meet specifications or which appears to have any defect which may make the material unsuitable for use in the Project. The Contractor shall notify Intermountain and the manufacturer or supplier of all defects and assist Intermountain in arranging for the repair, replacement or correction of the defective condition. The Contractor shall not be entitled to an extension of any deadline or completion date which results from failure to discover defects which the Contractor should have discovered through an inspection.
- (iv) Defective Materials: The Contractor acknowledges that use of improper or defective material may result in costs and damages to Intermountain in excess of the value of the materials; that after use in the Project it may be difficult or impossible to inspect the material to determine the cause of any failure; and that in the event of the failure of material there may be a question as to the cause of the failure. Because the Contractor's employees will be the last to handle and inspect material prior to incorporation into the Project, the Contractor will be liable to Intermountain for damages resulting from failure of Intermountain- purchased materials during the Contractor's warranty period specified herein from any cause whatsoever unless the Contractor provides clear and convincing proof that (1) the entire loss from a failure is covered by a valid manufacturer's or supplier's warranty, or (2) the Contractor could not have prevented the failure by complying with the requirements of this Section concerning Intermountain-purchased materials.
- (v) Claims: The Contractor agrees to assist Intermountain to present claims to manufacturers and suppliers for defects in Intermountain-purchased materials. Where there is any question as to the division of liability between the Contractor and a manufacturer or vendor, the Contractor shall provide all relevant information in the Contractor's possession which may aid Intermountain in determining the division of responsibility. Intermountain shall have final approval of any proposed adjustment or settlement of warranty claims.

- (vi) Implied Warranties: The benefit of contractual and implied warranties with respect to Intermountain-purchased materials and equipment shall run to Intermountain and not to the Contractor.
 - (vii) Unloading: Except as otherwise provided herein, the Contractor shall be responsible for unloading all Intermountain-purchased materials and equipment and for verifying delivery amounts to Intermountain.
 - (viii) Custody and Security: The Contractor shall secure and protect Intermountain-purchased materials and equipment from loss, deterioration, damage, theft, vandalism or destruction. If any Intermountain-purchased materials or equipment are damaged, stolen, or lost, Contractor will timely replace such at Contractor's sole cost and expense. In such event, Contractor will not be entitled to any modification in Contract Time or Contract Sum.
 - (ix) Reports: At Intermountain's request, the Contractor shall furnish reports to the Intermountain Representative demonstrating the Contractor's compliance with this Section.
 - (x) Retained Ownership: All materials and equipment purchased by Intermountain which remain after completion of the Project shall be the property of Intermountain. If Intermountain does not wish to retain or dispose of surplus Intermountain-purchased materials or equipment, the Contractor shall remove and dispose of them.
- b. None of the foregoing duties of the Contractor with respect to Intermountain-purchased materials shall prevent Intermountain from exercising any prerogative of ownership of the materials or equipment.

4.6 Superintendent. Contractor will employ a competent superintendent and necessary assistants who will be in attendance at the Project site at all times during performance of the Work. The superintendent will represent Contractor, and communications given to the superintendent will be as binding as if given to Contractor. Important communications will be confirmed in writing. Other communications will be similarly confirmed on written request in each case.

4.7 Time and Contractor's Construction Schedules.

4.7.1 Progress and Completion.

- a. *Time Is of The Essence; Complete Within Contract Time.* Time is of the essence. By executing the Contractor's Agreement, Contractor confirms that the Contract Time is adequate to perform the Work. Contractor will proceed expeditiously with adequate forces to achieve Substantial Completion within the Contract Time.
- b. *Notice to Proceed and Insurance.* Contractor will not prematurely commence operations on the site or elsewhere before the issuance of a Notice to Proceed by Intermountain and in no event before the effective date of insurance required by Article 10 to be furnished by Contractor. In addition and without limitation of the foregoing, Contractor will not proceed with further Work or services after performing preconstruction services until Contractor receives a subsequent Notice to Proceed.

4.7.2 Schedule Preparation. Contractor, promptly after being awarded the Contract, will prepare and submit for Intermountain's and A/E's review a reasonably detailed CPM schedule for the Work. The schedule will indicate the order, sequence, and interdependence of all items known to be necessary to complete the Work including construction, procurement, fabrication, and delivery of materials and equipment, submittals and approvals of samples, shop drawings, procedures, or other documents. Work items of Intermountain, other Contractors, utilities and other third parties that may affect or be affected by Contractor will be included. If Intermountain is required, by the Contract Documents, to furnish any materials, equipment, or the like, to be incorporated into the Work by Contractor, Contractor will submit, with the first schedule submittal, a letter clearly indicating the dates that such

items are required at the Project site. The critical path should be identified, including the critical paths for interim completion dates and milestones. The CPM schedule will be developed using Primavera, MS Project, or Suretrack unless otherwise authorized by Intermountain Representative. Contractor's schedule will be updated at least once per month and submitted with each pay request. Contractor will maintain an original baseline schedule and will provide Intermountain monthly written reports indicating Contractor's compliance or noncompliance with the original schedule.

- 4.7.3 Initial Contract Time. Unless otherwise specified in the bidding documents, the initial Contract Time is the time identified in the Contractor's Agreement.
- 4.7.4 Interim Completion Dates and Milestones. The schedule must include contractually specified interim completion dates and milestones. The milestone completion dates indicated are considered essential to the satisfactory performance of this Contract and to the coordination of all Work on the Project. The milestone dates listed are not intended to be a complete listing of all Work under this Contract or of interfaces with other Project contractors.
- 4.7.5 Schedule Content Requirements. The schedule will indicate an early completion date for the Project that is no later than the Project's required completion date. The schedule, including all activity duration's will be given in calendar days. The Schedule will also indicate all of the following:
- a. Interfaces with the work of outside contractors (e.g., utilities, power and with any separate Contractor);
 - b. Description of activity including activity number/numbers;
 - c. Estimated duration time for each activity;
 - d. Early start, late start, early finish, late finish date, and predecessor/successors including stop-start relationships with lead and lag time for each activity;
 - e. Float time available to each path of activities;
 - f. Actual start date for each activity begun;
 - g. Actual finish date for each activity completed;
 - h. The percentage complete of each activity in progress or completed;
 - i. Identification of all critical path activities;
 - j. The critical path for the Project, with this path of activities being clearly and easily recognizable on the time-scaled network diagram. The path(s) with the least amount of float time must be identified. Unless otherwise authorized by Intermountain Representative, no more than 40% of all activities may be identified as critical path items. The relationship between non-critical activities and activities on the critical path will be clearly shown on the network diagram;
 - k. Unless otherwise authorized by Intermountain Representative, all activities on the schedule representing construction on the site may not have duration longer than fourteen (14) Days. Construction items that require more than fourteen (14) Days to complete must be broken into identifiable activities on the schedule with durations less than fourteen (14) Days. The sum of these activities represents the total length required to complete that construction item; and
 - l. Additional requirements as specified in the Supplemental General Conditions.
- 4.7.6 Intermountain's Right to Take Exceptions. Intermountain reserves the right to take reasonable exception to activity duration, activity placement, construction logic or time frame for any element of the Work to be scheduled.

- 4.7.7 Float Time. Float time is defined as the amount of time between the earliest start date and the latest start date or between the earliest finish date and the latest finish date of a chain of activities on the Schedule. By a proposal request or modification delivered to Contractor, Intermountain has the right to use the float time for non-critical path activities until Contractor has reallocated such time on a newly submitted schedule.
- 4.7.8 Initial Schedule Submission. No progress payments will be approved until Contractor has submitted a Project detailed CPM schedule for the entire project.
- 4.7.9 Updates. Before any approval of a pay request, Intermountain, A/E and Contractor will review Contractor's schedule compared to the Work completed. Intermountain approves the amount of Work completed as supported by the schedule of values and as verified by the determination of Work completed. If necessary, Contractor will then update and submit to Intermountain the schedule with the pay request; all of which in accordance with Intermountain's approval. All updates will be provided in electronic and hard copy formats. At each scheduled meeting with Intermountain Representative, Contractor will provide at minimum a "three week look ahead" with long lead items identified.
- 4.7.10 Schedule of Submittals. Contractor will prepare and keep current, for A/E's and Intermountain's review, a schedule of submittals required under the Contract Documents which is coordinated with Contractor's construction schedule and allows A/E a reasonable time to review the submittals. This submittal schedule is to be included as part of the construction schedule. Submittals requiring expedited review must be clearly identified as such in the schedule of submittals.
- 4.7.11 Schedule Recovery. If the Work represented by the critical path falls behind by more than seven (7) Days, the project schedule will be redone within fourteen (14) Days showing how Contractor will recover the time. A narrative that addresses the changes in the schedule from the previously submitted schedule will be submitted along with the schedule in both hard copy (appropriate report formats to be determined by Intermountain Representative) and electronic copy. Contractor will comply with the most recent schedules.
- 4.7.12 Schedule Changes and Modifications.
- a. *Contract Time Change Requires Modification*. The Contract Time may only be shortened or extended by a Modification fully executed by Intermountain.
 - b. *Contractor Changing Activity Durations*. Should Contractor, after approval of the complete detailed construction schedule, desire to change his plan of construction, he will submit his requested revisions to Intermountain and A/E along with a written statement of the revisions including a description of the sequence and duration changes for rescheduling the work, methods of maintaining adherence to intermediate milestones and the contract completion date and the reasons for the revisions. If the requested changes are acceptable to Intermountain, which acceptance will not be unreasonably withheld, they will be incorporated into the Schedule in the next reporting period. If after submitting a request for change in the Contract Schedule, Intermountain does not agree with the request, Intermountain will schedule a meeting with Contractor to discuss the differences.
 - c. *Changes in Contract Time*. The critical path schedule as the term is used in the provisions herein will be based on the current version of Contractor's schedule for the Project and accepted by Intermountain just before the commencement of the modification, asserted delay, suspension or interruption. If Contractor believes it is entitled to an extension of Contract Time under the Contract Documents, Contractor will submit a PCO in accordance with Article 7.2 to A/E and Intermountain Representative accompanied by an analysis of the requested time adjustment.

4.7.13 Extensions of Time.

- a. If Substantial Completion of the Project is delayed because of any of the following causes, then the Contract Time will be extended by Modification for a period of time equal to such delay:
 - (i) Labor strikes or lock-outs;
 - (ii) Unusual delay in transportation;
 - (iii) Unforeseen governmental requests or requirements;
 - (iv) A Change in the Work resulting from an instruction by Intermountain or A/E to Contractor subject to the conditions set forth in Section 7.1.5;
 - (v) Unforeseen Subsurface Condition subject to the conditions set forth in Section 7.1.6; or
 - (vi) Any other event or circumstance caused by the willful or negligent act or omission of Intermountain or A/E subject to the conditions set forth in Section 7.1.6.
- b. Contractor will not be entitled to any compensation for delay described in Section 4.7.13, Paragraph a, subparagraphs (i), (ii), and (iii).
- c. In no event will any time extension or cost adjustment be given on account of delay which reasonably should have been anticipated by the Contractor or in circumstances where performance of the Work is, was, or would have been, delayed by any other cause for which the Contractor is not entitled to an extension.
- d. Adverse Weather delays. Completion time will not be extended for normal bad weather or any weather that is reasonably foreseeable at the time of entering into the contract. The time for completion as stated in the contract documents includes due allowance for calendar days on which Work cannot be performed due to weather conditions. The Contractor acknowledges that it may lose days due to weather conditions. Notwithstanding, the Contract Time may be extended (but at no cost to Intermountain) if all of the following are established by the Contractor:
 - (i) That the weather prevented Work from occurring that is on the critical path for the project based upon a critical path schedule previously submitted to Intermountain and to the extent accepted by Intermountain;
 - (ii) There are no concurrent delays attributed to the Contractor;
 - (iii) The Contractor took all reasonable steps to alleviate the impact of the weather and took reasonable attempts to prevent the delay and despite such reasonable actions of Contractor, the weather impacted the critical path as described above; and
 - (iv) One of the following occurred:
 1. The weather was catastrophic, such as a tornado, hurricane, severe wind storm, severe hail storm; or
 2. Based on the full history of information published from the closest station as indicated from the Western Regional Climate Center (Desert Research Institute 2215 Raggio Parkway Reno, Nevada 89512, and as may be described on the website at <http://www.wrcc.dri.edu/summary/>), one or more of the following occurred:
 - a. For any day between November 1 and March 31, the minimum temperature fell below the average minimum temperature plus the extreme low temperature recorded for the month divided by 2.
 - b. For any day between November 1 and March 31, the maximum temperature fell below the monthly average for the minimum temperature.
 - c. The daily precipitation exceeded 75% of the historical one day maximum for the month.

d. The snowfall for the month exceeded 175% of the historical average snow fall for the month.

Contractor will not be entitled to any compensation for Adverse Weather.

4.7.14 Time Extension Request. Unless a shorter time period is set forth herein or in other Contract Documents, any time extension will be requested by Contractor within twenty-one (21) Days after Contractor knew or should have known about the delay and will be supported by the critical path schedule analysis.

4.7.15 Delay in Completion of the Work.

- a. *Prior to Substantial Completion.* For each Day after the expiration of the Contract Time that Contractor has not achieved Substantial Completion, Contractor will pay Intermountain the amount set forth in the Agreement as liquidated damages for Intermountain's loss of use of the Project and the added administrative expense to Intermountain to administer the Project during the period of delay. In addition, Contractor will reimburse Intermountain for any additional Consultant's fees, attorney fees, expert fees, consultant fees, copy costs, and other expenses incurred by Intermountain as a result of the delay. The parties have agreed on this liquidated damages provision because actual damages which will result from a delay in Substantial Completion cannot readily be ascertained at the time of execution of the Agreement and the parties wish to fix such damages as a their reasonable estimate of such actual damages, and not as a penalty. Intermountain may deduct any liquidated damages or reimbursable expenses from any money due or to become due to Contractor. If the amount of liquidated damages and reimbursable expenses exceeds any amounts due to Contractor, Contractor will pay the difference to Intermountain within ten (10) Days after receipt of a written request from Intermountain for payment
- b. *After Substantial Completion.* For each Day that Contractor exceeds the time allowed for completion of the remaining items set forth in the Certificate of Substantial Completion, Contractor will pay to Intermountain as liquidated damages for additional administrative expenses the amount set forth in the Agreement. In addition, Contractor will reimburse Intermountain for any additional Consultant's fees, attorney fees, expert fees, consultant fees, copy costs, and other expenses incurred by Intermountain as a result of the delay in completing such items.
- c. *No Waiver of Intermountain's Rights.* Permitting Contractor to continue any part of the Work after the time fixed for completion or beyond any authorized extension thereof, will in no way operate as a waiver or estoppel on the part of Intermountain of any of its rights under the Contract Documents, including the right to liquidated damages or any other remedies or compensation.

4.8 Documents and Samples at the Site; Certifying "As-Builts". Contractor will maintain at the site for Intermountain, one record copy of the Drawings, Specifications, Addenda, Change Orders and other Modifications, in good order and marked weekly to record changes and selections made during construction, as well as approved Shop Drawings, Product Data, Samples and similar submittals. These items will be available to A/E and will be delivered to A/E for submittal to Intermountain upon completion of the Work, signed by Contractor, certifying that they show complete and exact "as-built" conditions and location, stating sizes, kind of materials, vital piping, conduit locations and similar matters. All notes of encountered or changed conditions will be included.

4.9 Shop Drawings, Product Data and Samples.

- 4.9.1 Not Contract Documents. Shop Drawings, Product Data, Samples and similar submittals are not Contract Documents. The submittal will demonstrate, for those portions of the Work for which the submittal is required, the way Contractor proposes to conform to the information given and the design concept expressed in the Contract Documents.
- 4.9.2 Promptness. Contractor will review, approve and submit to A/E, Shop Drawings, Product Data, Samples and similar submittals required by the Contract Documents with reasonable promptness and in such sequence as to cause no delay in the Work, or the activities of Intermountain or separate contractors.
- 4.9.3 Not Perform Until A/E Approves. Contractor will perform no portion of the Work requiring submittal and review of Shop Drawings, Product Data, Samples or similar submittals until the respective submittal has been approved in writing by A/E. Such Work will be in accordance with the approved submittals.
- 4.9.4 Representations by Contractor. By approving and submitting Shop Drawings, Product Data, Samples and similar submittals, Contractor represents that Contractor has determined and verified materials, field measurements and field construction criteria related thereto, and has checked and coordinated the information contained within such submittals with the requirements of the Work and of the Contract Documents.
- 4.9.5 Contractor's Liability. Contractor will not be relieved of responsibility for deviations from the requirements of the Contract Documents by A/E's approval of Shop Drawings, Product Data, Samples or similar submittals unless Contractor has specifically informed A/E in writing of such deviation at the time of the submittal and A/E has given written approval to the specific deviation. Contractor will not be relieved of responsibility for errors or omissions in Shop Drawings, Product Data, Samples or similar submittals by A/E's review and comment.
- 4.9.6 Direct Specific Attention to Revisions. Contractor will direct specific attention in writing to all revisions on resubmitted Shop Drawings, Product Data, Samples or similar submittals, except those requested by A/E and indicated on previous submittals.
- 4.9.7 Informational Submittals. Informational submittals upon which A/E is not expected to take responsive action may be so identified in the Contract Documents.
- 4.9.8 Reliance on Professional Certification. When professional certification of performance criteria of materials, systems or equipment is required by the Contract Documents, Intermountain and A/E will be entitled to rely upon the accuracy and completeness of such calculations and certifications. If a professional stamp is required, the professional will be licensed in the State in which the Project is located unless otherwise approved by Intermountain in writing. Likewise, Contractor is entitled to rely upon the accuracy and completeness of the calculations made by A/E in developing the Contract Documents, unless a Contractor of ordinary skill and expertise for the type of Work involved would know that such is inaccurate or incomplete and therefore must immediately notify Intermountain in writing.

4.10 Use of Site.

- 4.10.1 In General.
- a. Contractor will confine operations at the site to areas permitted by the Contract Documents, law, ordinances, resolutions, rules and regulations, and permits and will not unreasonably encumber the site with materials or equipment. Contractor will take all reasonable means to secure the site, protect the site and protect the Work from any damage. The site will be left free and clear of refuse, equipment, materials, etc. and the site will not be subject to spilled liquids and chemicals, toxic or otherwise. Should such an incident occur while Contractor has control of the site, Contractor will be responsible to clean the site and pay all associated costs, fines and penalties.

Notwithstanding this, Contractor is not responsible for any damage to the site or the Work to the extent caused by Intermountain or Intermountain's agents.

- b. Contractor recognizes that the Project site and the surrounding area is frequently visited by the public and is important to Intermountain's image and function and will maintain the premises free from debris and waste materials resulting from Construction. At the completion of Construction, Contractor will promptly remove construction equipment, tools, surplus materials, waste materials and debris.

4.10.2 Access to Neighboring Properties. Contractor will not, except as provided in the Contract Documents or with Intermountain's advance written consent when necessary to perform the Work, interfere with access to properties neighboring the Project site by the owners of such properties and their respective tenants, agents, invitees and guests.

4.11 Access to Work. Contractor will provide Intermountain and A/E access to the Work in preparation and progress, wherever located.

4.12 Royalties and Patents. Contractor will pay all royalties and license fees. Contractor will defend suits or claims for infringement of patent rights and will hold Intermountain and A/E harmless from loss on account thereof, but will not be responsible for such defense or loss when a particular design, process or product of a particular manufacturer or manufacturers is required by the Contract Documents. However, if Contractor has reason to believe that the required design, process or product is an infringement of a patent, Contractor will be responsible for such loss unless such information is promptly furnished to Intermountain in writing.

4.13 Indemnification.

4.13.1 To the fullest extent permitted by law, Contractor will indemnify and hold harmless Intermountain and its affiliates, subsidiaries, officers, employees, agents, authorized volunteers (hereinafter the above listing of entities and persons is referred to as "indemnitees") from and against every kind and character of claims, liabilities, damages, losses, settlements, and expenses, including but not limited to attorneys' fees, consultant fees, expert fees, and other costs and expenses, and including without limitation those events covered under the blanket Contractual Liability Coverage required under the Contract Documents, arising out of or resulting from performance of the Work, including without limitation the work of all the Subcontractors and their employees, except to the extent that such liability arises out of the negligence of Intermountain, its representatives, agents, and employees. This indemnity includes, without limitation, indemnification of Intermountain from all losses or injury to Intermountain's property, except to the extent that such loss or injury arises out of the negligence of Intermountain, its representatives, agents, and employees. This indemnity applies, without limitation, to include Claims occurring both during performance of the Work and/or subsequent to completion of the Work. In the event that any Claim is caused in part by a party indemnified hereunder, that party will bear the cost of such Claim to the extent it was the cause thereof. In the event that a claimant asserts a Claim for recovery against any party indemnified hereunder, the party indemnified hereunder may tender the defense of such Claim to Contractor. If Contractor rejects such tender of defense and it is later determined that the negligence of the party indemnified hereunder did not cause all of the Claim, Contractor will reimburse the party indemnified hereunder for all costs and expenses incurred by that party in defending against the Claim. Contractor will not be liable hereunder to indemnify any party for damages resulting from the sole negligence of that party. Notwithstanding, Intermountain will have the right, at its option, to participate in the defense of any such action without relieving Contractor of any obligation hereunder.

4.13.2 In addition to the foregoing, Contractor will be liable to defend Intermountain in any lawsuit filed by any Subcontractor relating to the Project. Where liens have been filed against Intermountain's property, Contractor (and/or its bonding company which has issued bonds for the Project) will obtain lien releases and record them in the appropriate county and/or local jurisdiction and provide

Intermountain with a title free and clear from any liens of Subcontractors. In the event that Contractor and/or its bonding company are unable to obtain a lien release, Intermountain in its absolute discretion may require Contractor to provide a bond around the lien or a bond to discharge the lien, at Contractor's sole expense.

- 4.13.3 In addition to the foregoing, Contractor will indemnify and hold Intermountain harmless from any claim of any other contractor resulting from the performance, nonperformance or delay in performance of the Work by Contractor.
- 4.13.4 The indemnification obligation under this Article 4.13 will not be limited by a limitation on amount or type of damages, compensation or benefits payable by or for Contractor or Subcontractor under workers' or workmen's compensation acts, disability benefits acts or other employee benefit acts.
- 4.13.5 Intermountain and Contractor waive all rights against each other for damages to the Work during construction to the extent covered by the applicable Builder's Risk Policy, except such rights as they may have to the proceeds of such insurance as set forth in the Contract. Contractor will require similar waivers from its Subcontractors, subconsultants, and agents, at any tier.

4.14 Additional Services/Work. It is understood and agreed by the parties hereto that no money will be paid to Contractor for additional labor or materials furnished unless a new contract in writing or a Modification hereof in accordance with the General Conditions and the Contract Documents for such additional labor or materials has been executed. Intermountain specifically reserves the right to modify or amend the Contract and the total sum due hereunder, either by enlarging or restricting the scope of the Work.

4.15 Building Information Modeling. Contractor will perform, throughout the Project, as requested by Intermountain and/or as otherwise required to execute the Project, building information modeling ("BIM") services and coordination among trades. Such BIM services are included in Contractor's Work and services and shall be provided by Contractor and Subcontractors without additional fee or charge to Intermountain. Contractor will provide BIM services using software acceptable to Intermountain.

5. SUBCONTRACTORS.

5.1 Award of Subcontracts and Other Contracts for Portions of the Work.

5.1.1 Approval Required.

- a. Listing of Subcontractors will be as stated in the Contract Documents, including but not limited to the "Intermountain Subcontractors List Form".
- b. Contractor will not contract with a proposed person or entity to whom Intermountain has made a reasonable and timely objection. Contractor will not be required to contract with anyone to whom Contractor has made reasonable objection.

5.1.2 Business and Licensing Requirements. All Subcontractors used by Contractor will comply with all applicable business and licensing requirements.

5.1.3 Subsequent Changes. After the bid opening, Contractor may change its listed Subcontractors only in accordance with the Contract Documents and with written approval of the Director.

- a. Intermountain will pay the additional costs for an Intermountain requested change in Subcontractor if all of the following are met:
 - (i) If Intermountain in writing requests the change of a Subcontractor;
 - (ii) The original Subcontractor is a responsible Subcontractor that meets the requirements of the Contract Documents; and
 - (iii) The original Subcontractor did not withdraw as a Subcontractor on the project.
- b. In all other circumstances, Contractor will pay the additional cost for a change in a Subcontractor.

- 5.1.4 Bonding of Subcontractors. Subcontractors as identified by Intermountain in the procurement documents, may be required to submit performance and payment bonds to cover the full extent of their portion of the Work. This provision does not in any way limit the right of Contractor to have Subcontractors at any tier be required to have a performance and/or payment bond.
- 5.1.5 Unrelated Subcontractors / Contractor Self-Performed Work.
- a. Contractor will procure bids for subcontract work from at least three (3) qualified bidders unless Intermountain waives such requirement in writing. Except as provided in the following section, Contractor will enter into contracts with Subcontractors not owned, related to or controlled by Contractor to perform all portions of the Work. Subcontracts will contain payment provisions consistent with the Contract Documents and will not be awarded on the basis of cost plus a fee without the prior written consent of Intermountain.
 - b. If Contractor wishes to self-perform any portion of the Work or subcontract such portion of the Work to an entity owned or controlled by or related to Contractor, Contractor will:
 - 1) Advise Intermountain at least thirty (30) Days in advance of bid opening that Contractor wishes to self-perform such Work or subcontract it to an entity owned, controlled by or related to Contractor and request Intermountain's written approval thereof;
 - 2) Submit to Intermountain Contractor's or such related entity's bid at least seventy-two (72) hours prior to bid opening;
 - 3) Procure bids for such subcontract Work from at least three qualified bidders unless Intermountain waives such requirement in writing; and
 - 4) Abide by Intermountain's determination as to whether Contractor or another subcontractor will be used to perform such Work.
 - c. If Intermountain both approves Contractor to self-perform Work and approves Contractor proceeding without obtaining bids from other Contractors, then Contractor's overhead and profit on Work performed by Contractor's crews will not be more than the percentage fee, if any, stated in the Contractor's Agreement or such fee as agreed by Intermountain and Contractor by a written Modification executed prior to Contractor's commencing the applicable self-performed Work.

5.2 Subcontractual Relations.

- 5.2.1 Comply with Contract Documents. By appropriate enforceable agreement, and to the extent it can be practically applied, Contractor will require each Subcontractor to be bound to Contractor by the terms of the Contract Documents, and to assume toward Contractor all the obligations and responsibilities which Contractor, by these Documents, assumes towards Intermountain and A/E.
- 5.2.2 Rights. Each Subcontractor agreement will preserve and protect the rights of Intermountain and A/E under the Contract Documents with respect to the Work to be performed by the Subcontractor so that subcontracting thereof will not prejudice such rights, and will allow to the Subcontractor, unless specifically provided otherwise in the Subcontractor agreement, the benefit of all rights and remedies against Contractor that Contractor, by the Contract Documents, has against Intermountain.
- 5.2.3 Sub-Subcontractors. Contractor will require each Subcontractor to enter into similar agreements with its Subcontractors which complies with the requirements of Paragraphs 5.2.1 and 5.2.2 hereinabove.
- 5.2.4 Document Copies. Contractor will make available to each proposed Subcontractor, before execution of the subcontract agreement, copies of the Contract Documents to which the Subcontractor will be

bound. Subcontractors will similarly make copies of applicable portions of the Contract Documents available to their respective proposed Subcontractors.

5.3 Contingent Assignment of Subcontracts. Each subcontract agreement for a Subcontractor, at any tier for a portion of the Work, is hereby assigned by Contractor to Intermountain provided that the assignment is effective only after termination of the Contract by Intermountain for cause pursuant to Article 12.2 or stoppage of the Work by Intermountain pursuant to Article 12.5, and only for those subcontract agreements which Intermountain accepts by notifying the Subcontractor in writing. The subcontract will be equitably adjusted to meet the new conditions of the work.

6. PROTECTION OF PERSONS AND PROPERTY.

6.1 Safety of Persons and Property.

- 6.1.1 Contractor Responsibility. Contractor will be solely responsible for initiating, maintaining and supervising all safety precautions and programs in connection with the performance of the Contract. Contractor will take all reasonable precautions for the safety of, and will provide reasonable protection to prevent damage, injury or loss to:
- a. Employees on the Work and other persons who may be affected thereby;
 - b. The Work and materials and equipment to be incorporated therein, whether in storage on or off the site, under care, custody or control of Contractor or a Subcontractor; and
 - c. Other property at the site or adjacent thereto, such as trees, shrubs, lawns, walks, pavements, roadways, structures and utilities not designated for removal, relocation or replacement in the course of construction.
- 6.1.2 Safety Program, Precautions. Contractor will institute a safety program at the start of construction to minimize accidents. This program will continue to the final completion of the Project and conform to applicable laws and regulations including the Utah Occupational Safety and Health Rules and Regulations as published by the Utah Industrial Commission - UOSH Division. Contractor will post signs, erect barriers, and provide those items necessary to implement the safety program. As soon as Contractor proceeds with the Work, Contractor will have all workers and all visitors on the site wear safety hard hats, as well as all other appropriate safety apparel such as safety glasses and shoes, and obey all safety rules and regulations and statutes. Contractor will post a sign in a conspicuous location indicating the necessity of wearing hard hats and Contractor will loan such hats to visitors.
- 6.1.3 Compliance with Safety Laws. Contractor will give notices and comply with applicable laws, ordinances, rules, codes, regulations and lawful orders of public authorities bearing on safety of persons or property or their protection from damage, injury or loss.
- 6.1.4 Erect and Maintain Safeguards. Contractor will erect and maintain, as required by existing conditions and performance of the Contract, reasonable safeguards for safety and protection, including effective fences, posting danger signs and other warnings against hazards, promulgating safety regulations and notifying owners and users of adjacent sites and utilities.
- 6.1.5 Utmost Care. When use or storage of explosives or other hazardous materials or equipment or unusual methods are necessary for execution of the Work, Contractor will exercise utmost care and carry on such activities under supervision of properly qualified personnel.
- 6.1.6 Prompt Remedy. Contractor will promptly remedy damage and loss (other than damage or loss insured under property insurance required by the Contract Documents) to property referred to in Paragraph 6.1.1 of these General Conditions caused in whole or in part by Contractor, a Subcontractor, or anyone directly or indirectly employed by any of them, or by anyone for whose acts they may be liable and for which Contractor is responsible under this Paragraph 6.1.1, except to the extent such damage or loss is directly due to errors in the Contract Documents or caused by agents or

employees of A/E or Intermountain. The foregoing obligations of Contractor are in addition to Contractor's obligations under the Contract Documents.

- 6.1.7 Safety Designee. Contractor will designate a responsible member of Contractor's organization at the site whose duty will be the prevention of accidents, damage, injury or loss. This person will be Contractor's superintendent unless otherwise designated by Contractor in writing to Intermountain and A/E.
- 6.1.8 Load Safety. Contractor will not load or permit any part of the construction or site to be loaded so as to endanger its safety.
- 6.1.9 Off-Site Responsibility. In addition to its other obligations under this Article 6, Contractor will, at its sole cost and expense, promptly repair any damage or disturbance to walls, utilities, streets, ways, sidewalks, curbs and the property of Intermountain and third parties (including municipalities and other governmental agencies) resulting from the performance of the Work, whether by it or by its Subcontractors at any tier. Contractor will not cause materials, including soil and debris, to be placed or left on streets or ways.
- 6.1.10 Emergencies. In an emergency affecting safety of persons or property, Contractor will act, at Contractor's discretion, to prevent threatened damage, injury or loss. Contractor will promptly notify Intermountain Representative of the action taken.

6.2 Hazardous Materials. In the event Contractor encounters on the site material reasonably believed to be asbestos or polychlorinated biphenyl (PCB) or any other hazardous waste or substance which may endanger the health of those persons performing the Work or being on the site, Contractor will immediately stop Work in the area affected and immediately report the condition to Intermountain Representative and A/E by phone with a follow-up document in writing. The Work in the affected area will be resumed when written direction is provided by Intermountain Representative. Except to the extent provided otherwise in the Contract Documents or if the presence of hazardous materials is due to the fault of Contractor, Contractor will not be required to perform without Contractor's consent, any Work relating to asbestos, polychlorinated biphenyl (PCB) or any other hazardous waste or substance. Intermountain will procure a licensed abatement contractor qualified to remove the hazardous material. The abatement contractor will submit notification of demolition to the Utah Division of Air Quality. Abatement contractor will pay the notification fee. A copy of the hazardous material survey report will be available to all persons who have access to the construction site.

6.3 Historical and Archeological Considerations. In the event Contractor knows or should have known of any cultural, historical or archeological material that is either recognized as an item to be protected under Federal, State, or local law or regulation, or is an item of obvious value to Intermountain, Contractor will cease any work that would interfere with such discovery and immediately report the condition to Intermountain Representative and A/E by phone with a follow-up document in writing. Work will resume based upon the direction of Intermountain Representative. Contractor cooperation with any Intermountain recognized archaeologist or other cultural/historical expert is required.

6.4 Contractor Liability. If Contractor fails in any of its obligations in Articles 6.1 through 6.3 above, Contractor will be liable to any damages to Intermountain or any third party resulting from such noncompliance. Contractor will also be liable for any mitigation or restoration effort resulting from such noncompliance. To the extent all the following is met, Contractor may treat the discovery of such material similarly to an unforeseen condition:

- 6.4.1 The discovery of such material is reasonably unforeseeable given the site conditions that Contractor should have been aware;
- 6.4.2 The presence of such material was not identified in any part of the Contract Documents;

- 6.4.3 Contractor has undertaken all proper action to mitigate any impact of such discovery on the critical path or monies related to the Project;
- 6.4.4 The discovery affects the critical path or contract price from that which was contemplated by the Contract Documents; and
- 6.4.5 The requirements of 7.1.5 and the Contract documents are met.

7. MODIFICATIONS, REQUEST FOR INFORMATION, PROPOSED CHANGE ORDER, AND CLAIMS PROCESS.

7.1 Modifications: In General.

- 7.1.1 Types of Modifications and Limitations. Changes in the Work may be accomplished after execution of the Contract, and without invalidating the Contract, by Change Order, Construction Change Directive or ASI, subject to the limitations stated in this Article 7 and elsewhere in the Contract Documents. Contractor must have a written Modification executed by Intermountain under this Article 7 before proceeding with any Work sought to be an extra.
- 7.1.2 By Whom Issued. A Change Order or Construction Change Directive will be issued by Intermountain Representative. An ASI is issued by A/E. A/E will prepare Change Orders and Construction Change Directives with specific documentation and data for Intermountain's approval and execution in accordance with the Contract Documents, and may issue ASIs not involving an adjustment in the Contract Sum or an extension of the Contract Time which are not inconsistent with the intent of the Contract Documents.
- 7.1.3 Contractor to Proceed Unless Otherwise Stated. Changes in the Work will be performed under applicable provisions of the Contract Documents, and Contractor will proceed promptly, unless otherwise provided in the Change Order, Construction Change Directive or ASI.
- 7.1.4 Adjusting Unit Prices. If unit prices are stated in the Contract Documents or subsequently agreed upon, and if quantities originally contemplated are so changed in a PCO or Construction Change Directive that application of such unit prices to quantities of Work proposed will cause a substantial inequity to Intermountain or Contractor, the applicable unit prices may be equitably adjusted.
- 7.1.5 Changes in the Work Resulting From An Instruction by Intermountain or A/E to Contractor.
 - a. If Intermountain or A/E gives Contractor an instruction that modifies the requirements of the Contract Documents or delays Substantial Completion, Contractor may be entitled to an adjustment in the Contract Sum and/or the Contract Time. If compliance with the instruction affects the cost to Contractor to perform the Work, the Contract Sum will be adjusted to reflect the reasonable increase or decrease in cost subject to the conditions set forth in Section 7.1.5, subparagraphs b through g. If compliance with the instruction delays Substantial Completion, the Contract Time will be extended for a period of time commensurate with such delay subject to the conditions set forth in Section 7.1.5, subparagraphs b through g and Section 4.7.13.
 - b. If Contractor receives an instruction from Intermountain or A/E that Contractor considers to be a Change in the Work, Contractor, before complying with the instruction, will notify A/E in writing that Contractor considers such instruction to constitute a Change in the Work. If A/E agrees that compliance with the instruction will constitute a Change in the Work, Contractor will furnish a proposal for a Modification in accordance with Section 7.1.5 subparagraphs c and d. within ten (10) Days.
 - c. If Contractor claims that it is entitled to an adjustment in the Contract Sum (including without limitation costs related to a time extension) as a result of an instruction by Intermountain or A/E, Contractor will furnish a proposal for a Change Order containing a price breakdown itemized as required by Intermountain. The breakdown will provide sufficient detail to allow Intermountain to determine any increase or decrease in Direct Costs as a result of compliance with the

instruction. Any amount claimed for subcontracts will be supported by a similar price breakdown and will itemize the Subcontractor's profit and overhead charges. Profit and overhead will be subject to the markup limits for additional work, changes, or other Modification set forth in the Contractor's Agreement. Amounts due Intermountain as a result of a credit change will be the actual net decrease in the Contractor's Direct Costs to perform the Work as a result of the Change in the Work. Overhead and profit for the Modification will be calculated based on the net increase or decrease in Contractor's Direct Costs resulting from the Change in the Work

- d. If Contractor claims that it is entitled to an adjustment in the Contract Time as a result of an instruction from Intermountain or A/E, Contractor will include in its proposal justification to support Contractor's claim that compliance with the instruction will delay Substantial Completion.
- e. Upon receipt of Contractor's proposal for Modification, A/E and Intermountain will determine whether to proceed with the Change in the Work. If A/E and Intermountain determine to proceed with the Change in the Work, they will execute a Change Order, a Construction Change Directive or a Field Change as appropriate.
- f. Contractor agrees that if it complies with an instruction from Intermountain or A/E without first giving written notice to A/E as provided in Section 7.15, subparagraph b, and receiving a Change Order, Construction Change Directive or Field Change, Contractor will not be entitled to any adjustment in the Contract Sum or the Contract Time as a result of the instruction and waives any claim therefor.
- g. If Contractor is instructed to perform work which it claims constitutes a Change in the Work but which Intermountain and A/E do not agree constitutes a Change in the Work, Contractor will comply with the instruction. Contractor may submit its claim for adjustment to the Contract Sum, the Contract Time, or both as a dispute pursuant to Section 7.7 within twenty-one (21) Days after compliance with the instruction. Contractor agrees that if it fails to submit its claim for resolution pursuant to Section 7.7 within twenty-one (21) Days after compliance with the instruction, then Contractor will not be entitled to any adjustment in the Contract Sum or the Contract Time as a result of the instruction and waives any claim therefor.
- h. Contractor agrees that it is responsible for submitting accurate cost and pricing data to support its Change Order Proposals. Intermountain will have the right to examine the Contractor's records to verify the accuracy and appropriateness of the pricing data used to price change order proposals.

7.1.6 Change in the Work Resulting From An Event or Circumstance.

- a. If an event or circumstance other than an instruction from Intermountain or A/E affects the cost to Contractor of performing the Work or delays Substantial Completion, Contractor may be entitled to an adjustment in the Contract Sum and/or the Contract Time. If the circumstance or event affects the cost to Contractor to perform the Work and is caused by a willful or negligent act or omission of Intermountain or A/E or an Unforeseen Subsurface Condition, the Contract Sum will be adjusted to reflect the reasonable increase or decrease in Contractor's cost to perform the Work resulting from the event or circumstance, subject to the conditions set forth in Section 7.1.6, subparagraphs b through f. If the event or circumstance delays Substantial Completion and is described in Section 4.7.13, the Contract Time will be extended for a period of time commensurate with such delay subject to the conditions set forth in such section. If the circumstance or event delays Substantial Completion and is caused by a willful or negligent act or omission of Intermountain or A/E or an Unforeseen Subsurface Condition, then Contractor will

be compensated for costs incident to the delay in accordance with Section 7.1.6, subparagraphs b through g and Section 4.7.13.

- b. Contractor will not be entitled to any adjustment to the Contract Sum or other damages from Intermountain as a result of any event or circumstance unless the event or circumstance results from a willful or negligent act or omission of Intermountain or A/E.
- c. If a Change in the Work results from any event or circumstance caused by the willful or negligent act or omission of Intermountain or A/E or an Unforeseen Subsurface Condition, Contractor will give Intermountain Written Notice of such event or circumstance within twenty-four (24) hours after commencement of the event or circumstance so that Intermountain can take such action as is necessary to mitigate the effect of the event or circumstance. Contractor will not be entitled to any adjustment in either the Contract Time or the Contract Sum based on any damages or delays resulting from such event or circumstance during a period more than twenty-four (24) hours prior to Contractor giving such Written Notice to Intermountain.
- d. Contractor will submit in writing any claims for an adjustment in the Contract Time and/or the Contract Sum resulting from an event or circumstance within the time limits set forth below. In the event that Contractor fails to submit its claim in writing within the time limits set forth below, then Contractor agrees it will not be entitled to any adjustment in the Contract Time or the Contract Sum or to any other damages from Intermountain due to the circumstance or event and waives any claim therefor.
 - (i) Claims for an adjustment in the Contract Time due to Adverse Weather will be made within twenty-one (21) Days of the first Day of the occurrence of the Adverse Weather event in which the delay occurred.
 - (ii) Claims for an adjustment in the Contract Time and/or the Contract Sum due to any other circumstance or event will be submitted within seven (7) Days after the occurrence of the circumstance or event.
- e. If Contractor claims that it is entitled to an adjustment in the Contract Sum (including without limitation costs related to a time extension) because of an event or circumstance resulting from the willful or negligent act or omission of Intermountain or A/E or an Unforeseen Subsurface Condition, Contractor will furnish a proposal for a Change Order containing a price breakdown as described in Section 7.1.5, subparagraph c. Any amount claimed for increased labor costs as a result of the event or circumstance must be supported by a certified payroll. Any claim for rented equipment or additional material costs must be supported by invoices.
- f. If Contractor claims that it is entitled to an adjustment in the Contract Time as a result of an event or circumstance, Contractor will include with its claim copies of daily logs, letters, shipping orders, delivery tickets, Project schedules, and other supporting information necessary to justify Contractor's claim that the event or circumstance delayed Substantial Completion.
- g. Within thirty (30) Days after receipt of Contractor's claim, A/E will either deny the claim or recommend approval to Intermountain. If Intermountain approves the claim, the adjustment in the Contract Time and/or Contract Sum will be reflected in a Change Order pursuant to Section 7.4 or a Construction Change Directive pursuant to Section 7.5. If Intermountain or A/E denies Contractor's claim, Contractor may submit its claim as a dispute pursuant to Section 7.7 within twenty-one (21) Days of receipt of the denial of the claim. If Contractor fails to submit its claim for resolution pursuant to Section 7.7 within the twenty-one (21) Day time period, then Contractor agrees it is not entitled to any adjustment in the Contract Time and/or Contract Sum or any other damages as a result of the event or circumstance and waives any claim therefor.

7.2 Contractor Initiated Requests.

- 7.2.1 The Request for Information, RFI, Process and Time to File. Contractor may file an RFI with A/E regarding any concern which will assist Contractor in the proper completion of the Work including, but not limited to issues related to the Contract Documents, plans and specifications. The RFI will be filed with A/E in a timely manner so as not to prejudice Intermountain as to the quality, time or money related to the Work.
- 7.2.2 Proposed Change Order. Unless a shorter time period is set forth herein or in other Contract Documents, within twenty-one (21) Days after Contractor knows or should have known of a situation or concern where Contractor is going to request additional monies or time, Contractor must file a PCO with Intermountain Representative, or Contractor will be deemed to waive any right to claim additional monies or time related to such situation or concern. The PCO will include all available documentation supporting the PCO available to Contractor at the time of filing and Contractor will thereafter diligently pursue the supplementation(s) of such documentation and promptly deliver such supplementation(s) to Intermountain Representative.
- a. *Intermountain Representative Response.* One of the following may occur after a PCO is filed with Intermountain Representative:
- (i) Intermountain Representative, after considering any input by A/E, may reach an agreement with Contractor and issue a Change Order.
 - (ii) Intermountain, after considering any input by A/E, may issue a Construction Change Directive.
 - (iii) If Intermountain Representative, after considering any input by A/E, disagrees with Contractor's PCO, Intermountain representative may seek additional information or verification from Contractor, A/E or other sources, may negotiate with Contractor, may issue a Change Order upon such later agreement, may retract the PR, or may issue a Construction Change Directive. A/E must continually work with Intermountain in providing data, documentation and efforts to resolve the issues related to the PR.

7.3 Proposal Request Initiated by Intermountain. Intermountain may file a Proposal Request with Contractor seeking information, data and/or pricing relating to a change in the Contract Time and or monies owing for particular scope changes or other modifications to the Contract Documents. The PR will provide a time limit for Contractor to file a response with A/E and Intermountain Representative. If a proposal is not timely provided by Contractor, Intermountain may calculate the Change Order under Article 7.4.2 below. Upon such timely receipt of the proposal, one of the following will occur:

- 7.3.1 If Agreement, Change Order Issued. Intermountain Representative, after considering any input by A/E, may reach an agreement with Contractor and issue a Change Order.
- 7.3.2 If Disagreement. If Intermountain Representative disagrees with Contractor's proposal, after considering any input from A/E, Intermountain representative may seek additional information or verification from Contractor or other sources, may negotiate with Contractor, may issue a Change Order upon such later agreement, may retract the PR, or may issue a Construction Change Directive. If a Construction Change Directive is issued which identifies Intermountain representative's position in regard to the subject contract sum and/or time adjustment, Contractor must initiate the Claim resolution process provided for herein within twenty-one (21) Days of Contractor's receipt of the Construction Change Directive, or Contractor will be deemed to waive any such request for additional time or money as a result of the issuance of the Construction Change Directive. Such waiver will entitle Intermountain to convert the Construction Change Directive into a Change Order, whether or not executed by Contractor. If the Construction Change Directive leaves open the determination of additional time or money related to the directed change, then the time period for initiating the Claim resolution process will not accrue until such time as Intermountain has conveyed to Contractor a position as to the time and money owing as a result of the directed change.

7.4 Evaluation of Proposal for Issuing Change Orders.

- 7.4.1 Adjusting Sum Based Upon Agreement. If the Change Order provides for an adjustment to the Contract Sum, the adjustment will be based on the mutual agreement of Contractor and Intermountain, including any terms mandated by unit price agreements or other terms of the Contract Documents.
- 7.4.2 Intermountain Resolution of Sum and Standards in the Absence of an Agreement Under Paragraph 7.4.1. In the absence of an agreement under Paragraph 7.4.1 above, the adjustment will be based on an itemized accounting of costs and savings supported by appropriate data. Unless otherwise provided in the Contract Documents, costs for the purposes of this Paragraph will be limited to the following:
- a. All direct and indirect costs of labor; including workers compensation insurance, social security and other federal and state payroll based taxes, and payroll based fringe benefits paid by Contractor so long as they are reasonable and no higher than that charged to other clients;
 - b. Costs of materials, on-site temporary facilities, supplies and equipment (except hand tools) required for or incorporated into the work;
 - c. Rental costs of machinery, equipment, tools (except hand tools), and on-site temporary facilities, whether rented from Contractor or others;
 - d. Costs of permits and other fees, sales, use or similar taxes related to the Work (with no markup);
 - e. Additional costs of field supervision and field office personnel directly attributable to the change; and
 - f. Overhead and profit by the markup limits in the Agreement for additional services or modifications which is not a penalty but a reasonable calculation agreed upon at the time of execution of the Agreement, and provided therein due to the fact that the actual amount due for this overhead and profit cannot easily be ascertained at the time of such execution. The markups set forth in the Agreement are to cover additional payment and performance bond premiums, insurance premiums, home office and on-site overhead and profit. Overhead and profit includes, but is not limited to Contractor's Project Manager and Cost Estimator. Each request for pricing will stand on its own and not be combined with other requests for pricing in determining the allowed markup. A particular request for pricing will include all items reasonably related together and determinable at the time of the request. If several unrelated requests for pricing are grouped together in a single Change Order, each request for pricing will be considered separately for purposes of calculating the markup.
- 7.4.3 Credits. The amount of credit to be allowed by Contractor to Intermountain for a deletion or change which results in a net decrease in the Contract Sum will be actual net cost as confirmed to Intermountain based upon corroboration by an appropriate source.

7.5 Construction Change Directives.

- 7.5.1 When Used and Contractor's Right to Challenge. A Construction Change Directive may be issued by Intermountain Representative in the case of a need for the Work to commence. If the Construction Change Directive leaves open the determination of additional time or money related to the directed change, then the Construction Change Directive will indicate the timeframe(s) in which further information is to be provided to resolve the matter. At any time that Intermountain and Contractor agree upon the time and money related to a Construction Change Directive, a Change Order will be executed by the parties. Additionally, the Construction Change Directive may be converted to a Change Order under Paragraph 7.2.2 or Article 7.3 above.
- 7.5.2 Proceed with Work and Notify Intermountain about Adjustment Method. Upon receipt of a Construction Change Directive, Contractor will promptly proceed with the change in the Work involved.

7.5.3 Interim Payments by Intermountain. Pending the final determination of the total cost of the Construction Change Directive, Intermountain will pay any undisputed amount to Contractor.

7.6 A/E's Supplemental Instruction (Commonly referred to as an "ASI"). A/E may at any time that is consistent with maintaining the quality, safety, time, budget and function of the Work, issue to Contractor a supplemental instruction ("ASI") after approval from Intermountain Representative is obtained. Contractor must file with Intermountain Representative a PCO under Paragraph 7.2.2 above, within twenty-one (21) Days of Contractor's receipt of the ASI, or the Contractor will be deemed to have waived any right to additional time or monies as a result of such ASI.

7.7 Resolution of Disputes. If a dispute arises between the Parties regarding the Contract Documents which is not resolved by agreement between the parties, before a party may proceed with judicial action, the dispute must be submitted in writing to Intermountain's Vice President of Financial Strategy, Growth and Development, at 36 South State Street, Salt Lake City, Utah 84111. Upon receipt of such written submission, Intermountain will schedule within seven (7) Days an initial conference or meeting, and if necessary within an additional ten (10) Days thereafter a further conference or meeting, as set forth in the escalation process herein below.

7.7.1 Escalation Process. The Parties will arrange in-person meetings or telephone conferences at mutually convenient times and places, according to the levels and time schedules set forth below. The Parties will use reasonable and good faith efforts in this escalation process to respond promptly and to resolve the dispute. Such meetings or conferences will constitute settlement negotiations and any settlement proposal made pursuant to such meetings or conferences will not be admissible as evidence of liability.

<u>Levels and Representatives</u>	<u>Allotted Time Period from Notice or from Previous Level</u>
<u>Level 1</u> Contractor's Director level employee, and Intermountain's Director	7 Days
<u>Level 2</u> Vice President or higher level executive	10 Days

7.7.2 Judicial Action. In the event that the parties do not resolve their dispute pursuant to the escalation process, either party may commence legal action to resolve the dispute. Any such action must be commenced within six (6) months from the first day of the initial Level 1 conference/meeting or be time barred. Submission of the dispute under the escalation process as outlined above is a condition precedent to the right to commence legal action to resolve any dispute. In the event that either party commences legal action to adjudicate any dispute without first submitting the dispute under the escalation process, the other party will be entitled to obtain an order dismissing the litigation without prejudice and awarding such other party any costs and attorney fees incurred by that party in obtaining the dismissal, including without limitation copy costs, and expert and consultant fees and expenses. Any such legal action must be brought exclusively in the state courts of the State of Utah or in the federal courts of the United States which are located in Salt Lake County, Utah. The Parties hereto hereby agree to submit to the exclusive jurisdiction and venue of such courts for the purposes hereof.

7.7.3 Continuation of Performance During Proceedings. Pending final resolution of a dispute hereunder, Contractor will proceed diligently with the performance of its obligations under the Contract Documents.

7.8 Payment of Claim.

- 7.8.1 When a standalone component of a Claim has received a final determination, and is no longer subject to review or appeal, that amount will be paid in accordance with the payment provisions of the Contract Documents or judicial order.
- 7.8.2 When the entire Claim has received a final determination, and is no longer subject to review or appeal, the full amount will be paid within thirty-one (31) Days of the date of the final determination unless the work or services has not been completed, in which case the amount will be paid in accordance with the payment provisions of the Contract Documents to the point that the work or services is completed.
- 7.8.3 The final determination date is the earlier of the date upon which the claimant accepted the settlement in writing with an executed customary release document and waived its rights of appeal, or the expiration of the appeal period, with no appeal filed, or the determination made resulting from the final appeal.
- 7.8.4 Any final determination where Intermountain is to pay additional monies to Contractor will not be delayed by any appeal or request for judicial review by another party brought into the process by Intermountain as being liable to Intermountain.
- 7.8.5 Notwithstanding any other provision of the Contract Documents, payment of all or part of a Claim is subject to any set-off, claims or counterclaims of Intermountain.
- 7.8.6 Payment to Contractor for a Subcontractor issue (Claim) deemed filed by Contractor, will be paid by Contractor to the Subcontractor in accordance with the contract between Contractor and the Subcontractor.
- 7.8.7 The execution of a customary release document related to any payment may be required as a condition of making the payment.

7.9 Allocation of Costs of Claim Resolution Process.

- 7.9.1 Except for attorneys' fees and expert fees, and unless otherwise agreed to by the parties to the Claim, the costs of resolving the Claim will be allocated among the parties on the same proportionate basis as the determination of financial responsibility for the Claim. The costs of resolving the Claim that are subject to allocation include the claimant's filing fee, the costs of any person(s) evaluating the Claim, the costs of making any required record of the process, and any additional testing or inspection procured to investigate and/or evaluate the Claim.
- 7.9.2 The prevailing party in any Claim, judicial action or other proceeding is entitled to recover its reasonable attorneys' fees, expert and other fees, and costs incurred in the proceeding, in addition to any other relief to which that party may be entitled.

7.10 Alternative Procedures. To the extent otherwise permitted by law, if all parties to a Claim agree in writing, a protocol for resolving a Claim may be used that differs from the process described in this Article 7.

8. PAYMENTS AND COMPLETION.

8.1 Schedule of Values. With the first Application for Payment, Contractor will submit to A/E and Intermountain Representative a schedule of values allocated to all the various portions of the Work. The Schedule of Values will be submitted on the form approved and provided by Intermountain. A/E will make recommendations to Intermountain Representative regarding the Schedule of Values including any suggested modifications. When approved, including any approved modifications, by Intermountain Representative, it will be the basis for future Contractor Applications for Payments. Contractor will not be entitled to payment until receipt and acceptance of the Schedule of Values.

8.2 Applications for Payment.

8.2.1 In General. The following general requirements will be met:

- a. Not more than once a month, Contractor will submit to A/E an itemized Application for Payment for Work completed in accordance with the schedule of values and that reflects retainage as provided for in the Contractor's Agreement. Contractor's Applications for Payment will include conditional or final lien waivers (as applicable), in the forms attached to Contractor's Agreement for itself and from each Subcontractor requesting payment, covering all payments requested in the Application for Payment. The Application for Payment will be on a form provided by Intermountain.
- b. Such application will be supported by such data substantiating Contractor's right to payment as Intermountain or A/E may require. This data may include, but is not limited to, copies of requisitions from Subcontractors.
- c. Such applications may include requests for payment pursuant to approved Change Orders or Construction Change Directives.
- d. Such applications may not include requests for payment for portions of the Work performed by a Subcontractor when Contractor does not intend to pay to a Subcontractor because of a dispute or other reason.
- e. In executing the Application for Payment, Contractor will attest that Subcontractors involved with prior applications for payment have been paid, unless Contractor provides a detailed explanation why such payment may not have occurred. Intermountain reserves the right to require Contractor to submit a payment waiver from one or more Subcontractors.

8.2.2 Payment for Material and Equipment. Unless otherwise provided in the Contract Documents, payments will be made on account of materials and equipment delivered and suitably stored at the site for subsequent incorporation in the Work. If approved in advance by Intermountain and A/E, payment may similarly be made for materials and equipment suitably stored off the site at a location agreed upon in writing. Payment for materials and equipment stored on or off the site will be conditioned upon compliance by Contractor with procedures satisfactory to Intermountain to establish Intermountain's title to such materials and equipment or otherwise protect Intermountain's interest, and will include applicable insurance, storage and transportation to the site for such materials and equipment stored off the site. Intermountain may require copies of invoices or other suitable documentation.

8.2.3 Warranty of Title. Contractor warrants that title to all Work covered by an Application for Payment will pass to Intermountain no later than the time for payment. Contractor further warrants that upon submittal of an Application for Payment, all Work for which Certificates for Payment have been previously issued and payments received from Intermountain will, to the best of Contractor's knowledge, information and belief, be free and clear of liens, claims, security interests or encumbrances in favor of Contractor, Subcontractors, or other persons or entities making a claim by reason of having provided labor, materials and/or equipment relating to the Work.

8.2.4 Retainage and Holdback by Intermountain.

- a. *Holdback by Intermountain*. Notwithstanding anything to the contrary contained in the Contract Documents, Intermountain may, as a result of the Claim resolution process, withhold any payment to Contractor hereunder if and for so long as Contractor fails to perform any of its obligations hereunder or otherwise is in default under any of the Contract Documents.
- b. *Intermountain's Right to Withhold and Use Funds*. Intermountain may withhold from payment to Contractor such amount as, in Intermountain's judgment, may be necessary to pay just claims against Contractor or Subcontractors at any tier for labor and services rendered and materials furnished in and about the Work. Intermountain may apply such withheld amounts for the

payment of such claims in Intermountain's discretion. In so doing, Intermountain will be deemed the agent of Contractor and payment so made by Intermountain will be considered as payment made under the Contract by Intermountain to Contractor. Intermountain will not be liable to Contractor for any such payment properly made. Such withholdings and payments may be made without prior approval of Contractor and may also be made before any determination as a result of any dispute, Claim or litigation. However, Contractor will be notified before any such withholding and will be given an opportunity to inform Intermountain as to any reason why the withholding will not occur.

- c. *Statutory Retainage.* Notwithstanding and in addition, retainage in the amount of 5% will be withheld from each payment to Contractor for any Work under the Contract. The retainage, including any additional retainage imposed and the release of any retainage, will be in accordance with Intermountain policies, including restrictions of retainage regarding Subcontractors and the distribution of interest earned on the retention proceeds. After Contractor achieves Substantial Completion and submits its payment request for retained funds and provides statutory Conditional Waiver and Release documents executed by all subcontractors and suppliers having claim against the retained funds, Intermountain will pay any unpaid statutory retention, less any offsets or withholdings for specific deficiencies or disputes, within forty-five (45) Days. Notwithstanding the foregoing, Intermountain may (but is not obligated to), in its sole discretion, release from time to time any portion of retention funds for early completing subcontractors and/or otherwise reduce the overall retention funds withheld.
- d. *Intermountain Not Responsible for Contractor's Retention Requirements.* Intermountain will not be responsible for enforcing Contractor's obligations under Utah law in fulfilling the retention law requirements with Subcontractors at any tier.

8.2.5 Reimbursement to Intermountain. Notwithstanding any other provision of the Contract, Contractor will reimburse Intermountain for the portion of any expenses paid by Intermountain to Contractor, which is attributable to Contractor's breach of its duties under the Contract, including the breach of any duty by any Subcontractor or supplier at any tier or anyone for whom Contractor may be liable.

8.3 Certificates for Payment.

8.3.1 Issued by A/E. A/E will within ten (10) Days after receipt of Contractor's Application for Payment, either issue to Intermountain a Certificate for Payment, with a copy to Contractor, for such amount as A/E determines due, or notify Contractor and Intermountain in writing of A/E's reasons for withholding certification in whole or in part as provided in Paragraph 8.4.1. If A/E fails to act within this ten (10) Day period, Contractor may file the Application for Payment directly with Intermountain Representative and Intermountain will thereafter have thirty-one (31) Days from the date of Intermountain's receipt to resolve the amount to be paid and to pay the undisputed amount. The accuracy of Contractor's Applications for Payment will be Contractor's responsibility, not A/E's.

8.3.2 A/E's Representations. A/E's issuance of a Certificate for Payment will constitute a representation to Intermountain that to the best of A/E's knowledge, information and belief, based upon A/E's observations at the site, the data comprising the Application for Payment, and what is reasonably inferable from the observations and data, that the Work has progressed to the point indicated in the Application for Payment and that the quality of the work is in accordance with the Contract Documents. The foregoing representations are subject to minor deviations from the Contract Documents correctable before completion and to specific qualifications expressed by A/E. The issuance of a Certificate for Payment will further constitute a representation that Contractor is entitled to payment in the amount certified. However, the issuance of a Certificate for Payment will not be a representation that A/E has (a) made exhaustive or continuous on-site inspections to check the quality or quantity of the Work, (b) reviewed construction means, methods, techniques, sequences or procedures, (c) reviewed copies of requisitions received from Subcontractors and material suppliers and other data requested by Intermountain to substantiate Contractor's right to

payment, (d) ascertained how or for what purpose Contractor used money previously paid on account of Contract Sum, or (e) any duty to make such inquiries.

- 8.3.3 Contractor Respond to Financial Responsibility and Related Requests, Waivers, Releases, Bonds. Contractor will respond immediately to any inquiry in writing by Intermountain as to any concern of financial responsibility and Intermountain reserves the right to request any waivers, releases or bonds from Contractor in regard to any rights of Subcontractors (including suppliers) at any tier or any third-party before any payment by Intermountain to Contractor.

8.4 Decisions to Withhold Certification.

8.4.1 When Withheld. A/E may decide not to certify payment and may withhold a Certificate for Payment in whole or in part, to the extent reasonably necessary to protect Intermountain, if in A/E's judgment the representations to Intermountain required in Paragraph 8.3.2 above cannot be made. If A/E is unable to certify payment in the amount of the Application, A/E will notify Contractor and Intermountain as provided in Paragraph above. If Contractor and A/E cannot agree on a revised amount, A/E will promptly issue a Certificate for Payment for the amount to which A/E makes such representations to Intermountain. A/E may also decide not to certify payment or, because of subsequently discovered evidence or observations, may nullify the whole or part of a Certificate for Payment previously issued, to such extent as may be necessary in A/E's opinion to protect Intermountain from loss because of:

- a. Defective Work not remedied;
- b. Third party claims filed or reasonable evidence indicating probable filing of such claims;
- c. Failure of Contractor to make payments properly to Subcontractors or for labor, materials or equipment;
- d. Reasonable evidence that the Work cannot be completed for the unpaid balance of the Contract Sum;
- e. Damage to Intermountain or another contractor;
- f. Reasonable evidence that the Work will not be completed within the Contract Time, and that the unpaid balance would not be adequate to cover actual or liquidated damages for the anticipated delay; or
- g. Failure to carry out the Work in accordance with the Contract Documents.

8.4.2 Certification Issued When Reasons for Withholding Removed. When the reasons stated in Paragraph 8.4.1 for withholding certification are removed, certification will be made for such related amounts.

8.4.3 Continue Work Even If Contractor Disputes A/E's Determination. If Contractor disputes any determination by A/E or the result of the Claim resolution process with regard to any Certification of Payment, Contractor nevertheless will expeditiously continue to prosecute the Work.

8.4.4 Intermountain Not in Breach. Intermountain will not be deemed to be in breach of this Contract by reason of the withholding of any payment pursuant to any provision of the Contract Documents provided Intermountain's action or such withholding is consistent with the results of the dispute resolution process.

8.5 Progress Payments.

8.5.1 In General, Interest on Late Payments.

- a. Except as provided in Paragraph 8.3.1, Intermountain will pay any undisputed amount within thirty-one (31) Days of satisfaction of the following requirements: (i) Contractor has submitted the application for payment; (ii) A/E has issued to Intermountain a Certificate recommending payment; and (iii) Contractor has obtained conditional or unconditional waiver and release

documents executed by all of Subcontractors performing work and/or providing materials covered by the Contractor's payment request. In no event will Intermountain be required to pay any disputed amount.

- b. Except as otherwise provided by law, if any payment is made more than sixty (60) Days after receipt by Intermountain of the applicable invoice (with any required supporting documentation), the late payment will bear interest from the due date until payment is made at the rate of five percent (5%) per annum.

8.5.2 Contractor and Subcontractor Responsibility. Contractor will promptly pay each Subcontractor, upon receipt of payment from Intermountain, out of the amount paid to Contractor on account of such Subcontractor's portion of the Work, the amount to which this Subcontractor is entitled. Contractor will, by appropriate agreement with each Subcontractor, require each Subcontractor to make payment to its Subcontractors in a similar manner.

8.5.3 Information Furnished by A/E Or Intermountain to Subcontractor. A/E or Intermountain will, on request, furnish to the Subcontractor, if practicable, information regarding percentages of completion or amounts applied for by Contractor and action taken thereon by A/E and Intermountain on account of portions of the Work done by such Subcontractor.

8.5.4 Intermountain and A/E Not Liable. Neither Intermountain nor A/E will have an obligation to pay, monitor or enforce the payment of money to a Subcontractor, except to the extent as may otherwise be required by law.

8.5.5 Certificate, Payment or Use Not Acceptance of Improper Work. A Certificate for Payment, a progress payment, or partial or entire use or occupancy of the Project by Intermountain will not constitute acceptance of Work that is not in accordance with the Contract Documents.

8.6 Payment upon Substantial Completion. Upon Substantial Completion of the Work or designated portion thereof and upon application by Contractor and certification by A/E, Intermountain will make payment, reflecting adjustment in retainage, if any, for such Work or portion thereof as provided in the Contract Documents. To the extent allowed by law, Intermountain may retain up to 200% of the fair market value of the work that has not been completed in accordance with the Contract Documents.

8.7 Partial Occupancy or Use.

8.7.1 In General. Intermountain may occupy or use any completed or partially completed portion of the Work at any stage when such portion is designated by separate agreement with Contractor, and authorized by public authorities having jurisdiction over the Work. Such partial occupancy or use may commence whether or not the portion is Substantially Complete, provided Intermountain and Contractor have accepted in writing the responsibilities assigned to each of them for payments, retainage if any, security, maintenance, heat, utilities, damage to the Work and insurance, and have agreed in writing concerning the period for correction of the Work and commencement of the warranties required by the Contract Documents. When Contractor considers a portion to be substantially complete, Contractor will prepare and submit a list to A/E as previously provided for herein. Consent of Contractor to partial occupancy or use will not be unreasonably withheld. Contractor will have continuing responsibility to protect the unoccupied portions of the site and the Work during such partial occupancy and will be responsible for damage except to the extent caused solely by Intermountain during such partial occupancy or use.

The stage of progress of the Work will be determined by written agreement between Intermountain and Contractor.

8.7.2 Inspection. Immediately before such partial occupancy or use, Intermountain, Contractor and A/E will jointly inspect the area to be occupied or portion of the Work to be used in order to determine and record the condition of the Work.

- 8.7.3 Not Constitute Acceptance. Except to the extent it is agreed upon in writing by Intermountain, partial occupancy or use of a portion or portion of the Work will not constitute acceptance of Work not complying with the requirement of the Contract Documents.

8.8 Final Payment.

- 8.8.1 Certificate for Payment. A/E's final Certificate for Payment will constitute a further representation that the conditions listed in Paragraph 8.8.2 as precedent to Contractor's being entitled to final payment have been fulfilled.
- 8.8.2 Conditions for Final Payment. Neither final payment nor any remaining retained percentage will become due until Contractor submits to A/E the following to the extent required by Intermountain Representative:
- a. A final payment request;
 - b. Waiver and release upon final payment documents executed by all of the Subcontractors performing work and/or providing materials covered by the Contractor's final payment request;
 - c. All manufacturers' and other guaranties and warranties, properly signed and endorsed to Intermountain, that are required by the Contract Documents that extend for a period beyond one year after substantial completion. (Delivery of such guaranties and warranties will not relieve Contractor for any obligation assumed under any other provision of the Contract Documents.);
 - d. An affidavit that payrolls, bills for material and equipment, and other indebtedness connected with the Work for which Intermountain's property might be responsible or encumbered (less amounts withheld by Intermountain) have been paid or otherwise satisfied;
 - e. A current or additional certificate evidencing that insurance required by the Contract Documents to remain in force after final payment is currently in effect and will not be canceled or allowed to expire until at least thirty (30) Days prior written notice, by certified mail, return receipt requested, has been given to Intermountain;
 - f. A written statement that Contractor knows of no substantial reason that the insurance will not be renewable to cover the period required by the Contract Documents;
 - g. If requested by surety in a timely manner or by Intermountain, consent of surety, to final payment;
 - h. Up to date as built Drawings certified by Contractor as accurate and complete, Specifications, Addenda, Change Orders and other Modifications maintained at the site; the warranties, instructions, operation and maintenance manuals, and training videos required to be furnished by the Contract Documents;
 - i. Other data establishing payment or satisfaction of obligations, such as receipts, releases and waivers of liens, claims, security interests or encumbrances arising out of the Contract, to the extent and in such form as may be designated by Intermountain. If a Subcontractor refuses to furnish a release or waiver required by Intermountain, Intermountain may require consent of surety to the final payment. If such liens, claims, security interests or encumbrances remain unsatisfied after payments are made, Contractor will refund to Intermountain all money that Intermountain may be compelled to pay in discharging such lien, including all costs and reasonable attorneys' fees; and
 - j. A written statement demonstrating how Contractor will distribute interest earned on retention to Subcontractors as required by Section 13.8.5, U.C.A.

In addition, A/E must declare to Intermountain in writing that the Work is complete. If the aggregate of previous payments made by Intermountain exceeds the amount due Contractor, Contractor will reimburse the difference to Intermountain within ten (10) Days of Intermountain's request.

- 8.8.3 Waiver of Claims: Final Payment. The making of final payment will not constitute a waiver of Claims or other rights by Intermountain.
- 8.8.4 Waiver by Accepting Final Payment. Acceptance of final payment by Contractor or a Subcontractor will constitute a waiver of Claims by that payee except those Claims previously made in writing and identified by that payee as unsettled at the time of final Application for Payment.
- 8.8.5 Time of Repose and Waiver. In addition and notwithstanding, claims and invoices for work, equipment, services, or materials that are not submitted to Intermountain within one (1) year of Substantial Completion of the Project are completely void and unenforceable as against Intermountain. Contractor and all Subcontractors hereby waive all rights and claims against Intermountain attendant such claims and invoices, and Contractor will contractually obligate each Subcontractor to waive all rights and claims against Intermountain attendant such claims and invoices. This provision imposes an absolute cut off on the timing for submitting such claims and invoices; this provision does not lengthen any timing requirements in the Contract Documents.

9. TESTS AND INSPECTIONS, SUBSTANTIAL AND FINAL COMPLETION, UNCOVERING, CORRECTION OF WORK, AND GUARANTY PERIOD.

9.1 Tests and Inspections.

- 9.1.1 In General. Tests, inspections and approvals of portions of the Work required by the Contract Documents or by laws, ordinances, rules, regulations, resolutions or orders of public authorities having jurisdiction will be made at an appropriate time. Unless otherwise specifically set forth in the Contract Documents or agreed to by Intermountain in writing, Intermountain will contract for such tests, inspections and approvals with an independent entity, or with the appropriate public authority, and Intermountain will bear all related costs of tests, inspections and approvals except as provided below. If any of the Work is required to be inspected or approved by the terms of the Contract Documents or by any public authority, Contractor will, at least two working days before the time of the desired inspection, and following the procedures established by Intermountain, request such inspection or approval to be performed. Contractor will give A/E timely notice of when and where tests and inspections are to be made so that A/E may observe such procedures.
- 9.1.2 Failure of An Inspector to Appear. Work will not proceed without any required inspection and the associated authorization by Intermountain to proceed unless the following procedures and requirements have been met:
- a. The inspection or approval was requested in a timely manner as provided in Paragraph 9.1.1;
 - b. Contractor received written confirmation from the inspection entity that the inspection was scheduled;
 - c. Contractor has contacted or attempted to contact the inspector to confirm that the inspector is unable to perform the inspection as scheduled;
 - d. If the inspector has confirmed that it is unable to perform the inspection as scheduled or if Contractor is unable to contact the inspector, Contractor will attempt to contact Intermountain Representative for instruction; and Contractor has documented the condition of the work before being covered through photos or other means.
- 9.1.3 Nonconforming Work. If such procedures for testing, inspection or approval under Paragraph 9.1.1 reveal failure of portions of the Work to comply with the requirements established by the Contract Documents, Contractor will bear all costs made necessary by such failure including those of repeated procedures and compensation for Intermountain's expenses, including the cost of retesting for verification of compliance if necessary, until Intermountain accepts the Work in question as complying with the requirements of the Contract Documents.
- 9.1.4 Certificates. Required certificates of testing, inspection or approval will, unless otherwise required by the Contract Documents, be secured by Contractor and promptly delivered to A/E.

- 9.1.5 A/E Observing. If A/E is to observe tests, inspections or approvals required by the Contract Documents, A/E will do so with reasonable promptness and, where practicable, at the normal place of testing.
- 9.1.6 Promptness. Tests, inspections and arrangements for approvals conducted pursuant to the Contract Documents will be made promptly to avoid unreasonable delay in the Work.

9.2 Inspections: Substantial and Final.

- 9.2.1 Substantial Completion Inspection. Before requesting a substantial completion inspection, Contractor will prepare a comprehensive initial punchlist, including unresolved items from prior inspections, for review by Intermountain and A/E to determine if the Project is ready for a substantial completion inspection. If Intermountain determines that the initial punchlist indicates that the Project is not substantially complete, the initial punchlist will be returned to Contractor with written comments. If Intermountain determines that the initial punchlist indicates that the Project may be substantially complete, A/E will promptly organize and perform a Substantial Completion inspection in the presence of Intermountain and all appropriate authorities.
- a. If A/E reasonably determines that the initial punchlist prepared by Contractor substantially understates the amount of the Work remaining to be completed and the Project is not substantially complete, A/E will report this promptly to Intermountain, and upon concurrence of Intermountain, Contractor will be assessed the costs of the inspection and punchlist preparation incurred by A/E and Intermountain.
 - b. When the Work or designated portion thereof is Substantially Complete, A/E will prepare a Certificate of Substantial Completion which will establish the date of Substantial Completion; will establish responsibilities of Intermountain and Contractor for security, maintenance, heat, utilities, damage to the work and insurance; and will fix the time within which Contractor will finish all items on the punchlist accompanying the Certificate. The Certificate of Substantial Completion will require approval by Intermountain Representative. If there is a punchlist, Contractor will proceed promptly to complete and correct items on the list. Failure to include an item on the punchlist does not alter the responsibility of Contractor to complete all Work in accordance with the Contract Documents.
 - c. Warranties required by the Contract Documents will commence on the date of Substantial Completion of the Work or designated portion thereof except to the extent as provided otherwise in the Contract Documents or if such warranty is related to an item where the work is not complete. Such warranty documents will state the length of the warranty, which must comply with the Contract Documents.
 - d. The Certificate of Substantial Completion will be submitted by A/E to Intermountain and Contractor for their written acceptance of responsibilities assigned to them in such Certificate.
 - e. Except to the extent Intermountain Representative otherwise approves in advance and in writing, Contractor will submit the following documents in order to achieve Substantial Completion: written warranties, guarantees, operation and maintenance manuals, and all complete as-built drawings. Contractor must also provide or obtain any required approvals for occupancy. Contractor is responsible for the guaranty of all Work, whether performed by it or by its Subcontractors at any tier.
- 9.2.2 Final Completion Inspection. Before requesting a final inspection, Contractor will verify all punchlist items are corrected/completed. Once all punchlist items are corrected/completed Contractor will notify Intermountain and request a final inspection. Intermountain will notify A/E and perform a final inspection. Two final inspections may be allowed due to required weather changes required to complete some items. When all punchlist items are completed a final pay request will be provided by Contractor, authorized by A/E and processed by Intermountain.

9.3 Uncovering of Work.

- 9.3.1 Uncover Uninspected Work. Except as provided in Paragraph 9.3.3, if a portion of the Work is covered before an Inspector's approval to proceed, it must, be uncovered for the Inspector's inspection and be replaced at Contractor's expense without change in the Contract Time.
- 9.3.2 Observation before Covering. Except as provided in Paragraph 9.3.3, if Intermountain or A/E has requested in writing to observe conditions before any Work being covered or if such observation is specified in the Contract Documents, and the Work is covered without such observation, Contractor will be required to uncover and appropriately replace the Work at Contractor's expense without change in the Contract Time. If Contractor requests an inspection and Intermountain or A/E, including any inspector of each, does not appear, Contractor will immediately notify Intermountain of such lack of appearance, but will not cover the Work without such inspection.
- 9.3.3 When an Inspector Fails to Appear Or A/E Or Intermountain Did Not Make Prior Request. If Work is performed by Contractor without an inspection as provided in Paragraph 9.1.2 or if a portion of the Work has been covered which A/E or Intermountain has not specifically requested to observe before its being covered or such observation is not specified by the Contract Documents, A/E or Intermountain may request to see such Work and it will be uncovered by Contractor. If such Work is in accordance with the Contract Documents, costs of uncovering and replacement, will, by appropriate Change Order, be charged to Intermountain. If such Work is not in accordance with the Contract Documents, Contractor will pay such costs unless the condition was caused by Intermountain or a separate contractor in which event Intermountain will be responsible for payment of such costs.

9.4 Correction of Work and Guaranty Period.

- 9.4.1 Contractor Correct the Work. Contractor will correct Work rejected by A/E, Inspector or Intermountain, or failing to conform to the requirements of the Contract Documents, whether observed before or after Substantial Completion and whether or not fabricated, installed or completed. Contractor will bear the costs of correcting such rejected Work, including additional testing and inspections and compensation for A/E's and Inspector's services and expenses made necessary thereby.
- 9.4.2 Guaranty and Correction after Substantial Completion. If within one year after the date of Substantial Completion of the Work or designated portion thereof, or after the date for commencement of warranties established under Paragraph 9.2.1 or by terms of an applicable special warranty or guaranty required by the Contract Documents, any of the Work is found to be not in accordance with the requirements of the Contract Documents, including failure to perform for its intended purpose, Contractor will correct it promptly after receipt of written notice from Intermountain to do so unless Intermountain has previously given Contractor a written acceptance of such condition. The period of one year will be extended with respect to portions of the Work first performed after Substantial Completion by the period of time between Substantial Completion and the actual performance of the Work. This obligation of Contractor under this Paragraph 9.4.2 will be operative notwithstanding the acceptance of the Work under the Contract, the final certificate of payment, partial or total occupancy and/or termination of the Contract. Intermountain will give notice of observed defects with reasonable promptness, however, failure to give such notice will not relieve Contractor of its obligation to correct the Work at the cost that Contractor would have incurred if Intermountain did so report with reasonable promptness. All corrected Work will be subject to a one-year guaranty period the same in all respects as the original Work, except that such guaranty period will commence from the time of Substantial Completion of the corrected Work. This guaranty period does not affect Intermountain's right to pursue any available remedies against Contractor.

9.4.3 Removal of Work.

- a. Contractor will promptly remove from the premises all Work that Intermountain and/or A/E determines as being in nonconformance with the Contract Documents, whether incorporated or not.
- b. Contractor will promptly replace and re-execute the Work in accordance with the Contract Documents and without expense to Intermountain.
- c. Contractor will bear the expense of correcting destroyed or damaged construction, whether completed or partially completed, of Intermountain or of other contractors destroyed or damaged by such removal or replacement.
- d. If Contractor does not remove such rejected Work within a reasonable time, fixed by written notice, Intermountain may have the materials removed and stored at the expense of Contractor.
- e. If Contractor does not correct the nonconforming Work within a reasonable time, fixed by written notice, Intermountain may correct it in accordance with Paragraph 12.2.2 of these General Conditions.

9.4.4 Not Limit Other Obligations. Nothing contained in this Article 9.4 will be construed to establish a period of limitation with respect to other obligations which Contractor may have under the Contract Documents. Establishment of the time period of one year as described in Paragraph 9.4.2 relates only to the specific obligation of Contractor to correct the Work, and has no relationship to the time within which the obligation to comply with the Contract Documents may be sought to be enforced, nor to the time within which proceedings may be commenced to establish Contractor's liability with respect to Contractor's obligations other than specifically to correct the Work.

9.5 Additional Warranties.

9.5.1 In General. In addition to any other provisions of this Article 9, the following warranties will apply:

- a. Contractor warrants to Intermountain that materials and equipment furnished under the Contract will be of good quality and new, except to the extent otherwise required or expressly permitted by the Contract Documents.
- b. Contractor also warrants to Intermountain that the Work will be free from defects not inherent in the quality required or permitted and that the Work will conform to the requirements of the Contract Documents. Work not conforming to these requirements, including substitutions not properly approved and authorized, may be considered Defective at Intermountain's option.

9.5.2 Correction of Work.

- a. Contractor will promptly correct any portion of the Work which is rejected by A/E, the inspector, or Intermountain, or which fails to conform to the requirements of the Contract Documents, whether observed before or after Substantial Completion and whether or not fabricated, installed, or completed. Contractor will bear the cost of correcting such rejected Work, including additional testing and inspection costs, compensation for A/E's services, and any other expenses made necessary thereby. Such costs will in no way be payable by Intermountain and will not increase the Contract Sum.
- b. Contractor will remedy any Defects due to faulty materials, equipment, or workmanship which appear within a period of one (1) year from the date of Substantial Completion or within such longer period of time as may be prescribed by law or by the terms of any applicable special warranty required by the Contract Documents. Contractor will pay all costs of correcting faulty work, including additional A/E fees, attorney fees, expert fees, consultant fees, copy costs, and other expenses when incurred. Such costs will in no way be payable by Intermountain and will not increase the Contract Sum.

- c. Nothing in the Contract Documents will be construed to establish a period of limitation within which Intermountain may enforce the obligation of Contractor to comply with the Contract Documents. The one (1) year period specified in paragraph 9.5.2(2) has no relationship to the time within which Intermountain may enforce compliance with the Contract Documents, nor to the time within which proceedings may be commenced to establish Contractor's liability with respect to Contractor's obligations.

9.5.3 Exclusion. Unless due to the negligent or intentional act or omission of Contractor or those under Contractor's control, or as otherwise stated in the Contract Documents, Contractor's guaranty excludes remedy for damage or defect caused by abuse, modifications not executed by Contractor, improper or insufficient maintenance, improper operation, or normal wear and tear under normal usage.

9.5.4 Furnish Evidence on Request. If requested by A/E or Intermountain, Contractor will furnish satisfactory evidence as to the type and quality of materials and equipment.

9.6 Acceptance of Nonconforming Work. If Intermountain prefers to accept Work which is not in accordance with the requirements of the Contract Documents, Intermountain may do so in writing instead of requiring its removal and correction, in which case the Contract Sum will be reduced as appropriate and equitable. Such adjustment will be effected whether or not final payment has been made. Without limitation, usage by Intermountain or A/E of mechanical devices, machinery, apparatus, equipment, or other work or materials supplied under the Contract Documents before written acceptance by Intermountain, will not constitute Intermountain's acceptance.

10. INSURANCE AND BONDS.

10.1 Insurance. To protect against liability, loss and/or expense arising in connection with the performance of services described under the Contract Documents, Contractor will obtain and maintain in force as set forth below in section 10.1.9 without interruption, the following stated insurance, in a form and content satisfactory to Intermountain, from insurance companies authorized to do business in the State in which the Project is located with an A.M. Best's Rating of A- or better and Class VII or better. Contractor will require all Subcontractors to have and maintain similarly required policies. All of the following listed insurance coverages will be provided by Contractor.

10.1.1 Contractor's Commercial General Liability Insurance. Contractor will maintain coverage, with ISO Form CG 00 01 or other policy form satisfactory to Intermountain, on an occurrence basis, including coverage for Premises-Operations, Independent Contractors' Protective, Products-Completed Operations, Contractual Liability, Personal Injury, and Broad-Formed Property Damage (including coverage for Explosion, Collapse, and Underground hazards), which will provide primary coverage to the additional insureds (Intermountain and the A/E) in the event of any occurrence, claim, or suit, with per occurrence and annual aggregate policy limits of at least as follows:

\$2,000,000	General Aggregate;
\$2,000,000	Products-Completed Operations Aggregate;
\$1,000,000	Personal and Advertising Injury;
\$1,000,000	Each Occurrence.

Intermountain reserves the right to require additional coverage limits of liability from that stated above. Intermountain also reserves the right to require project specific insurance, and if such right has been exercised it will be indicated in the Contract Documents.

10.1.2 Excess and Umbrella Liability Insurance. Contractor will maintain excess and liability insurance with coverage at least as broad as the underlying liability insurance described in this section, written on an occurrence basis with per occurrence and annual aggregate policy limits based on the following chart, unless modified by mutual agreement of the parties,

Small Project (\$2,000,000 or less)
Minimum Commercial General Liability Coverage
\$1,000,000 each occurrence,
\$3,000,000 general aggregate

Medium Project (\$2,000,001 to \$10,000,000)
Minimum Commercial General Liability Coverage
\$5,000,000 each occurrence,
\$10,000,000 general aggregate

Large Project (Greater than \$10,000,000)
Minimum Commercial General Liability Coverage
\$10,000,000 each occurrence,
\$20,000,000 general aggregate

For insurance purposes, the size of the Project will be specified in the Contractor's Agreement. Such excess or umbrella liability policy will follow form with the primary liability policies, and contain a drop-down provision in case of impairment of underlying limits.

- 10.1.3 Workers' Compensation Insurance and Employers' Liability Insurance. Worker's Compensation Insurance will cover full liability under the Worker's Compensation Laws of the jurisdiction in which the Project is located at the statutory limits required by this jurisdiction's laws. Contractor will also maintain Employer's Liability Insurance with limits of at least \$1,000,000 each accident, \$1,000,000 for bodily injury by accident, and \$1,000,000 each employee for injury by disease. Contractor will collect and keep on-file evidence that Contractor and all tiers of Subcontractors have current certificates of this Workers Compensation Insurance (as required by State statute) as well as Employer's Liability Insurance, and will produce them upon request by Intermountain.
- 10.1.4 Automobile. Automobile liability insurance for claims arising from the ownership, maintenance, or use of a motor vehicle. The insurance will be written on an "occurrence" form and will apply to "any auto" and will cover all owned, non-owned, and hired automobiles used in connection with the work, with the following minimum limits of liability: \$1,000,000 – Combined Single Limit Bodily Injury and Property Damage per Occurrence.
- 10.1.5 Pollution Liability Insurance. Pollution Liability Insurance covering Contractor's or appropriate Subcontractor's liability for bodily injury, property damage and environmental damage resulting from sudden, accidental, and gradual pollution and related cleanup costs incurred by Contractor, all arising out of the goods delivered or Work and services performed (including transportation risk) under this Contract, is required with limits of at least \$1,000,000 per claim and \$1,000,000 annual aggregate.
- 10.1.6 Aircraft Use. Contractor using its own manned or unmanned aircraft, or employing manned or unmanned aircraft in connection with the work performed under the Contract Documents will maintain Aircraft Liability Insurance with a combined single limit of not less than \$1,000,000 per occurrence. This certificate will state that the policy required by this paragraph has been endorsed to name Intermountain as an Additional Insured.
- 10.1.7 Policy Aggregate(s). Unless project specific insurance is required by Intermountain, the above insurance coverages will be written or endorsed under a policy to have general, per occurrence, and aggregate limits of liability applicable to this project only.
- 10.1.8 Certificates. Before the Contract Documents are executed, Contractor will submit certificates in form and substance satisfactory to Intermountain as evidence of the insurance requirements of this Article 10. Contractor will obtain copies of Additional Insured (Ongoing and Completed Operations), Waiver of Subrogation, and Primary and Non-Contributory Endorsements and/or policy clauses. The certificates will contain provisions that no cancellation, or non-renewal will become effective except upon thirty (30) Days prior written notice by US Mail to Intermountain as evidenced by return receipt, certified mail sent to Intermountain. Contractor will notify Intermountain within thirty (30) Days of

any claim(s) against Contractor which singly or in the aggregate exceed 20% of the applicable required insured limits and Contractor will, if requested by Intermountain, use its best efforts to reinstate the policy within the original limits and at a reasonable cost. Intermountain will be named as an additional insured party, as primary coverage and not contributing, on all the insurance policies required by this Article, except the professional liability and workers' compensation policies, by endorsements satisfactory to Intermountain -- using a combination of ISO forms CG 20 10 (07/04), Additional Insured – Owners, Lessees or Contractors – Scheduled Person or Organization and CG 20 37 (07.04) Additional Insured – Owners, Lessees or Contractors – Completed Operations, or other forms acceptable to Intermountain, naming Intermountain and A/E as additional insureds. Intermountain reserves the right to request Contractor to provide a loss report from its insurance carrier. Contractor will collect and keep on-file evidence that Contractor and each Subcontractor has current certificates of Commercial General Liability Insurance, Excess /Umbrella Liability Insurance, and other insurance required herein, and will produce them upon request by Intermountain.

- 10.1.9 Maintain throughout Contract Documents Term. Contractor will maintain, from commencement of the Work, insurance coverage required in Articles 10.1 and 10.2 as follows:
- a. Commercial General Liability Insurance through expiration of the statute of limitations/repose for completed operations, but in no event less than ten (10) years from completion of the Project; and
 - b. All other insurance through final payment.
- 10.1.10 Waivers of Subrogation. Contractor waives all rights against Intermountain and other additional insureds for recovery of damages to the extent the losses and damages are covered by existing insurance, including without limitation commercial general liability, commercial excess/umbrella liability, business auto liability, workers compensation or employer's liability insurance, and pollution liability insurance. Contractor will ensure that all insurance policies required herein will be endorsed to include waivers of subrogation in favor of Intermountain. Contractor hereby waives all rights of subrogation against Intermountain.
- 10.1.11 Excess Coverages. Any type of insurance or any increase of limits of liability not described in the Contract Documents which Contractor requires for its own protection or on account of any statute, rule or regulation, will be its own responsibility and at its own expense.
- 10.1.12 Not Relieve Contractor of Liability. The carrying of any insurance required by the Contract Documents will in no way be interpreted as relieving Contractor of any other responsibility or liability under the Contract Documents or any applicable law, statute, rule, regulation, or order.
- 10.1.13 Contractor Compliance with Policies. Contractor will not violate or permit to be violated any of the provisions of the insurance policies required under the Contract.
- 10.1.14 Deductible Liability. Any and all deductibles in the above described policies will be assumed by, for the account of, and at the sole risk of Contractor. The allowable deductible for any of the Contractor insurance policies required by these General Conditions shall be no less than \$1,000 or 0.1 percent of the Contract Amount, whichever is greater.

10.2 "Builder's Risk" Property Insurance.

- 10.2.1 In General. Intermountain will provide through Substantial Completion "Builder's Risk" property insurance for the cost of the Project. The policy will be written on an all risk basis, with exclusions standard for the insurance industry, on policy forms currently and commercially available, with insurance carriers selected by Intermountain.
- 10.2.2 Deductible. The above described "Builder's Risk" policies shall be subject to a total deductible of \$5,000 per loss occurrence, which deductible shall be assumed by Contractor or Subcontractors, in proportion to their share of the total amount of an insured loss occurrence.

- 10.2.3 Waiver. To the extent damages are covered by the above described “Builder’s Risk” policies, Contractor, including all Subcontractors and Material Suppliers, and Intermountain hereby waive all rights against each other for damages caused by perils insured against under the “Builder’s Risk” insurance provided. Contractor will require similar waivers from each of their contractors, subcontractors, material suppliers, sub-consultants and agents, at any tier.
- 10.2.4 Policy Terms. Intermountain will provide a copy of the terms and conditions of the builders risk policy to Contractor upon Contractor’s request. Contractor will comply with terms, conditions, and deadlines of the builders risk policy. The terms, conditions, and deadlines of the builders risk policy shall govern coverage. Contractor will cooperate with Intermountain and the builders risk commercial insurer in the investigation, documentation, and settlement of loss claims, including without limitation promptly responding to all requests for information and documentation from the builders risk commercial insurer and/or Intermountain.
- 10.2.5 Special Hazards. Intermountain will bear the risk of loss, delay and/or damage due to earthquake and/or flood and may either insure or self-insure that risk.

10.3 Performance Bond and Payment Bond. If required by the Contract Documents, Contractor will before commencement of the Work or within ten (10) Days after signing the Agreement, whichever is earlier, submit and maintain in full force and effect as required by law and the Contract Documents, as part of the Construction Costs for the Project, written on Form AIA Document A312 (1984) or on other forms provided by Intermountain, and include as part of the quoted total all costs involved in securing and furnishing, a performance bond and a labor and material payment bond the bonds listed below, based on the completed cost of the Contract and effective upon execution of the Contract. These bonds will be from a surety company or companies licensed in the state in which the Project is located and holding valid certificates of authority under Sections 9304 to 9308, Title 31, of the United States Code as acceptable sureties or reinsurance companies on federal bonds, have a penal sum obligation not exceeding the authorization shown in the current revision of Circular #570 as issued by the United States Treasury Department, i.e. “Treasury List”, and be accompanied by a certified copy of the power of attorney stating the authority of the attorney-in-fact executing the bonds on behalf of the surety.

- a. A full 100 percent performance bond covering the faithful execution of the Contract in accordance with the Contract Documents; and
- b. A full 100 percent payment bond covering payment of all obligations arising under the Contract Documents, for the protection of each person supplying labor, service, equipment, or material for the performance of the Work.

All Subcontractor performance and payment bonds will name Contractor and Intermountain as Obligee. Intermountain reserves the right to reject any surety company, performance bond, or labor and material payment bond with or without cause.

10.4 Intermountain Self-Insurance. Intermountain may, at its option, satisfy any insurance requirements applicable to Intermountain through its self-insurance and risk management program.

11. MISCELLANEOUS PROVISIONS.

11.1 A/E’s Responsibilities. These General Conditions are not intended to provide an exhaustive or complete list of A/E’s responsibilities. A separate agreement between Intermountain and A/E incorporates these General Conditions by reference and includes additional design responsibilities.

11.2 Successors and Assigns. Intermountain and Contractor respectively bind themselves, to the other party in respect to covenants, agreements and obligations contained in the Contract Documents. Contractor will not assign the Contract, or any of its rights or obligations under the Contract, without the prior written consent of Intermountain, nor will Contractor assign any amount due or to become due as well as any rights under the Contract, without prior written consent of Intermountain. Intermountain may assign the

Contract to an institutional lender providing financing for the Project. In such event, the lender will assume Intermountain's rights and obligations under the Contract. Contractor will execute all consents reasonably required to facilitate such assignment.

11.3 Written Notice. Written notice will be deemed to have been duly served if (a) delivered in person to the individual or a member of the firm or entity or to an officer of the corporation for which it was intended, or (b) delivered at or sent by registered or certified mail, return receipt requested, or (c) deposited for delivery with a nationally recognized overnight courier service, to the last business address known to the party giving notice.

11.4 Rights and Remedies.

11.4.1 **Not Limit.** Duties and obligations imposed by the Contract Documents and rights and remedies available thereunder will be in addition to and not a limitation of duties, obligations, rights and remedies otherwise imposed or available by law.

11.4.2 **Not Waiver.** Except as expressly provided elsewhere in the Contract Documents, no action or failure to act by Intermountain, A/E or Contractor will constitute a waiver of a right or duty afforded them under the Contract Documents, nor will such action or failure to act constitute approval or acquiescence in a breach thereunder, except as any of the above may be specifically agreed to in writing. In no case will Contractor or any Subcontractors be entitled to rely upon any waiver of any of these General Conditions unless agreed to in writing by Intermountain.

11.5 Use of Intermountain Forms. Unless otherwise specifically identified in the Contract, all references or requirements for use or submission of documents to Intermountain, to A/E, or to others must be on Intermountain's approved forms. These forms include, without limitation, pay application, requests for payment, proposed change orders, change orders, modifications, requests for information, continuation sheets, waiver and lien releases, verifications, and other project related documents. Notwithstanding, Intermountain may in its sole discretion accept alternate forms. However, Intermountain's acceptance of an alternate form in one instance does not waive or modify the requirements herein for subsequent submissions.

11.6 Governing Law, Jurisdiction and Venue. To the maximum extent permitted by law, Utah laws, excluding its conflict-of-law provisions, govern the Contract and both Intermountain and Contractor submit to the exclusive jurisdiction and venue of state and federal courts located in Salt Lake County, Utah.

11.7 Interpretation. In the interest of brevity, the Contract Documents frequently omit modifying words such as "all" and "any" and articles such as "the" and "an", but the fact that a modification or an article is absent from the statement and appears in another is not intended to affect the interpretation of either statement.

11.8 Severability. The invalidity of any part, paragraph, subparagraph, phase, provision or aspect of the Contract documents will not impair or affect in any manner the validity, enforceability or effect of the remainder of the Contract Documents.

11.9 Construction of Words. Unless otherwise stated in the Contract Documents, words, which have well-known technical or construction industry meanings, will be construed as having such recognized meanings. Unless the context requires otherwise, all other technical words will be construed in accordance with the meaning normally established by the particular, applicable profession or industry. All other words, unless the context requires otherwise, will be construed with an ordinary, plain meaning.

11.10 No Third-Party Rights. The Contract Documents will not be construed to create a contractual relationship of any kind (1) between A/E and Contractor, (2) between Intermountain and a Subcontractor or (3) between any persons or entities other than Intermountain and Contractor. Nothing contained herein will be deemed as creating third party beneficiary contract rights or other actionable rights or duties as

between Contractor and A/E, or as between Intermountain, Contractor, or A/E on the one hand, and any other person or entity.

- 11.11 Change of Control.** If a third party acquires a controlling interest (i.e., 50% ownership or more) of Contractor, then (a) Contractor will notify Intermountain within fifteen (15) Days of that acquisition, and (b) upon that acquisition, Intermountain may terminate for cause the Contract immediately upon written notice to Contractor.
- 11.12 Entire Agreement and Amendment Limitation.** The Contract represents the entire and integrated agreement between Intermountain and Contractor and supersedes all prior negotiations, representations or agreements, either written or oral. The Contract may be amended or modified only by (1) a written amendment executed by both Intermountain and Contractor, or (2) by a Modification.
- 11.13 Notices.** Any notice required by the Contract will be served upon the recipient's designated representative by hand delivery at the last known business address, or by mail or nationally recognized overnight courier service with "delivery confirmation" to the last known address.
- 11.14 No Publicity.** Without receiving prior written approval from an Intermountain vice president, Contractor will not distribute any publicity regarding the Contract.
- 11.15 Waivers.** No waiver by Intermountain or Contractor of any default will constitute a waiver of the same default at a later time or of a different default.
- 11.16 Waiver of Consequential Damages.** Intermountain and Contractor waive all claims against each other for any consequential damages that may arise out of or relate to the Contract. Intermountain waives damages including but not limited to is loss of use of the Project, any rental expenses incurred, loss of income, profit, or financing related to the Project, loss of business, the services of employees, or loss of reputation. Contractor waives damages including but not limited to the loss of business, loss of financing, principal office overhead and expenses, loss of profits not related to this Project, loss of bonding capacity or loss of reputation. This section may not be construed to preclude recovery of consequential damages when such damages are actually recovered from insurance policies required by the Contract Documents. The provisions of this section also apply to the termination of the Contract and survive such termination.
- 11.17 Compliance.**
- 11.17.1 Remuneration. Remuneration flowing between the parties is at fair market value for actual and necessary items furnished or services rendered, is based upon an arm's-length transaction, and does not take into account, directly or indirectly, the value or volume of any past or future referral or other business generated between the parties (or of any referral or business of any principal, affiliate, or immediate family member - as those terms may be defined by applicable laws - of either party).
- 11.17.2 Financial Relationships. To its knowledge, Contractor (a) is not a physician-owned entity and (b) has no prohibited financial relationship with any physician who is in a position to generate business for Intermountain, or with an immediate family member of that physician. Intermountain defines a "physician-owned entity" as any entity in which a physician, or immediate family member of a physician, holds an ownership, investment, or royalty interest (if royalties are paid on any purchase resulting from the royalty holder's order). The Code of Federal Regulations (CFR) defines "financial relationship" (in 42 CFR 411.354) and "immediate family member" (in 42 CFR 411.351).
- [Note: Physicians and their immediate family members may own investment securities of Contractor if that investment complies with 42 CFR 411.356(a) or (b), and may have a compensation arrangement that both complies with 42 CFR 411.357(p) and does not take into account the volume or value of referrals or other business generated for Intermountain by a physician or a physician's immediate family members.]

- 11.17.3 Exclusion or Sanction. Contractor warrants that neither it, or any of its affiliates or employees, excluded from participation in, or sanctioned under, any state or federal healthcare program, including those set forth in 42 U.S.C. §1320a 7b(f). Contractor will notify Intermountain immediately in writing if the warranty in the preceding sentence is, or becomes, inaccurate during the Term.
- 11.17.4 Access to Books and Records. Intermountain is a provider under Federal Medicare programs and is subject to Section 952 of the Omnibus Reconciliation Act of 1980. That law requires Intermountain, as a provider, to include the following provision in its agreements with suppliers who receive \$10,000 or more under an agreement with Intermountain. If requested by the Secretary of HHS, by the U.S. Comptroller, or by an authorized representative of either of them, Contractor will make available to the requestor the Contract and Contractor's books, documents, and records to allow the requestor to certify the nature and extent of the charges for services provided under the Contract and charged to Medicare. Contractor will continue to make those items available for four years after Contractor furnishes the final products (or services) under the Contract. If Contractor contracts with another to carry out any of Contractor's duties under the Contract and the Subcontractor is to receive \$10,000 or more in value under that subcontract, then Contractor will obtain a written contractual commitment from the Subcontractor to comply with the obligations of this section of the Agreement. The obligations of this Section survive the expiration or other termination of the Contract.
- 11.17.5 Code of Ethics. In its dealings with Intermountain, Contractor has and will comply with all codes of ethics applicable to suppliers and their interactions with purchasers like Intermountain, including, without limitation, the AdvaMed Code of Ethics on Interactions with Health Care Professionals.
- 11.17.6 Facility Access Policy. All of Contractor's representative(s) entering any Intermountain facility must comply with Intermountain's Facility Access Policy. This policy requires each of these Contractor representatives to check in with Intermountain on each visit to an Intermountain facility to receive an identification badge; and as applicable, log onto: <https://intermountainhealthcare.org/supply-chain-organization/for-suppliers/for-current-suppliers/access-to-intermountain-facilities/> and complete the registration requirements. Please contact Intermountain representative with any questions.
- 11.17.7 Equal Opportunity. Affirmative Action. Intermountain is an equal opportunity employer and federal contractor. Consequently, the parties agree that, to the extent applicable, they will comply with the following, which are incorporated herein by reference: 41 CFR 60 1.4(a), 41 CFR 60 300.5(a), 41 CFR 60 741.5(a), and Executive Order 13496 (29 CFR Part 471, Appendix A to Subpart A), relating to the notice of employee rights under federal labor laws, specifically:
- a. Intermountain and Contractor will abide by the requirements of 41 CFR 60 300.5(a), as applicable. This regulation prohibits discrimination against qualified protected veterans, and requires affirmative action by covered prime contractors and Subcontractors to employ and advance in employment qualified protected veterans.
 - b. Intermountain and Contractor will abide by the requirements of 41 CFR 60 741.5(a), as applicable. This regulation prohibits discrimination against qualified individuals on the basis of disability, and requires affirmative action by covered prime contractors and Subcontractors to employ and advance in employment qualified individuals with disabilities.
- 11.17.8 Remedies. If Contractor breaches any obligation of this section, Intermountain may immediately terminate for cause the Contract upon written notice to Contractor.

11.18 Work Restrictions / Drug Testing. Contractor will ensure that Contractor, its agents, employees, and all Subcontractors do not use or consume alcohol or cannabis, or illegally use drugs, upon Intermountain's property or enter upon or perform any work on Intermountain's property while under their influence. Contractor will obtain necessary consents and will conduct periodic inspections and drug testing to monitor and ensure compliance with these requirements. Contractor will bear the expenses of such inspections and drug testing and will hold Intermountain harmless from all claims arising out of or relative thereto. In addition, Contractor will ensure that Contractor and all Subcontractors do not smoke or vape

anything upon Intermountain's property except and only within designated smoking areas approved by Intermountain.

11.19 Utah State Sales Tax. Contractors should be exempt on purchases of material installed or converted into real property to be used by Intermountain. The Contractor will furnish each vendor with Intermountain's Tax exemption number.

11.20 Notice of Intent to Obtain Final Completion. Contractor shall file with the Utah State Construction Registry, on its own behalf and/or on behalf of Intermountain, a notice of intent to obtain final completion at least forty-five (45) Days before the day on which Intermountain or Contractor files or could file a notice of completion under Utah statutes if: (1) the completion of performance time under the original contract for construction work is greater than one hundred twenty (120) Days; (2) the total original construction contract price exceeds \$500,000; and (3) neither Contractor nor Intermountain has obtained a payment bond in accordance with Utah Code Ann. Section 14-2-1.

11.21 Notice of Completion. Within five (5) Days of final completion of the Project and in compliance with Section 38-1a-507 Utah Code Annotated, Contractor shall file with the Utah State Construction Registry, and copy to Intermountain, a notice of completion which shall include, without limitation, the following:

- a. The name, address, telephone number, and email address of the person filing the notice of completion;
- b. The name of the county in which the Project and/or Project site is located;
- c. The date on which final completion is alleged to have occurred;
- d. The method used to determine final completion; and
- e. One of the following:
 1. The tax parcel identification number of each parcel included in the Project and/or Project site;
 2. The entry number of a preliminary notice on the same project that includes the tax parcel identification number of each parcel included in the Project and/or Project site; or
 3. The entry number of the building permit issued for the Project.

Notwithstanding any other provision of the Contract Documents to the contrary, Contractor and Intermountain agree that any breach or failure to comply with this requirement by Contractor will constitute a breach of contract and the Contractor will be liable for any direct, indirect, or consequential damages to Intermountain flowing from this breach.

11.22 Audit Rights. Contractor will keep, maintain and preserve complete, current and accurate books, records, and accounts of the transactions contemplated by this Agreement and such additional books, records and accounts as are necessary to establish and verify Contractor's compliance with the Contract. All these books, records and accounts will be available for inspection and audit by Intermountain and/or an independent third party designated by Intermountain and approved by Contractor at any time during the Term and for two (2) years thereafter, but only during reasonable business hours and upon reasonable notice. In addition:

- a. Intermountain agrees that its routine audits will not be conducted more frequently than once in any consecutive twelve (12) month period.
- b. If, after any audit of Contractor, Intermountain requires additional information regarding the transactions contemplated by the Contract, Contractor will furnish to Intermountain or to the third-party audit firm any additional information Intermountain specifies that relates to the audit period to establish and verify Contractor's compliance with the Contract Documents.

- c. Intermountain's right to inspect and audit is without prejudice to any other or additional rights or remedies of either party.
- d. Contractor agrees to not unreasonably withhold approval of any independent third-party audit firm.
- e. If an audit reveals an overcharge incurred by Intermountain on this Project, Contractor will provide a written response explanation, correct any error and remit any monies due within ten (10) Days after receiving notice of the error or overcharge.

Intermountain may audit applications for payments or any other aspect of the Services and Work of Contractor and of the Subcontractor or suppliers at any tier. Contractor will cooperate with Intermountain in providing all necessary information for any Intermountain audit.

12. TERMINATION OR SUSPENSION OF THE CONTRACT.

12.1 Termination by Contractor.

12.1.1 In General. If the Work is stopped for a period of ninety (90) Days through no act or fault of Contractor or a Subcontractor, or their agents or employees or any other persons performing portions of the Work under contract with any of the above, Contractor, may terminate the Contract in accordance with 12.1.2 herein below for any of the following reasons:

- a. Because Intermountain has persistently failed to fulfill fundamental Intermountain's obligations under the Contract Documents with respect to matters important to the progress of the Work;
- b. Issuance of an order of a court or other public authority having jurisdiction which necessitates such termination, except that where Contractor has standing, Contractor must cooperate in efforts to stay and/or appeal such order;
- c. A governmental declaration of national emergency, making material unavailable; or
- d. Unavoidable casualties or other similar causes as listed in Paragraph 12.2.2(2) herein below.

12.1.2 Notice. If one of the reasons for termination in Paragraph 12.1.1 hereinabove exist, Contractor may, upon ten (10) additional Days' written notice to Intermountain and A/E, and such condition giving cause for termination still not cured, terminate the Contract and recover from Intermountain payment for Work executed and for proven loss with respect to materials, equipment, tools, and construction equipment and machinery, including reasonable overhead, profit and damages associated only with work completed before the notice of termination.

12.2 Termination by Intermountain for Cause.

12.2.1 In General. Intermountain may terminate the Contract if Contractor fails to cure any of the following within a period of ten (10) Days (or longer if Intermountain so approves in writing) after receipt of notice from Intermountain specifying the cause for termination:

- a. Contractor refuses or fails to supply enough properly skilled workers or proper materials;
- b. Contractor fails to make payment to Subcontractors for materials or labor in accordance with the respective agreements between Contractor and the Subcontractors;
- c. Contractor disregards laws, ordinances, or rules, regulations, resolutions or orders of a public authority having jurisdiction; or
- d. Contractor fails to perform the Work within the time specified in the Contract Documents or any authorized extension thereof or Contractor fails to make progress with the Work as to endanger such compliance;
- e. Contractor fails to perform the Work or is otherwise in breach of a provision of the Contract Documents;

- f. Contractor fails to respond promptly to the financial responsibility inquiry herein;
 - g. As permissible by law for a reason to terminate, Contractor is adjudged bankrupt;
 - h. As permissible by law for a reason to terminate, Contractor should make a general assignment for the benefit to creditors;
 - i. As permissible by law for a reason to terminate, Contractor has or should have a receiver appointed on account of Contractor's insolvency; or
 - j. Contractor fails to follow the material safety requirements and precautions either as expressly provided in the Contract Documents or as consistent with the customary practices in the industry.
- 12.2.2 Intermountain's Right to Carry Out the Work. If Contractor defaults or neglects to carry out the Work in accordance with the Contract Documents and fails within a ten (10) Day period (or longer if approved by Intermountain in writing) after receipt of written notice from Intermountain to cure such default or neglect, Intermountain may without prejudice to other remedies Intermountain may have, correct such deficiencies, including taking over the Work and prosecuting the same to completion, by contract or otherwise, and may take possession of, and utilize in completing the Work, such materials, appliances, and facilities as may be on the site of the Work as well as the site as necessary for its proper completion. In such case, Intermountain will offset from payments then or thereafter due Contractor the cost of correcting such deficiencies, including compensation for A/E, Intermountain's staff and legal counsel's additional services and expenses made necessary by such default, neglect or failure. If payments then or thereafter due Contractor are not sufficient to cover such amounts, Contractor will pay the difference to Intermountain. Contractor will continue performance of the Contract to the extent not terminated.
- 12.2.3 Items Required to Be Transferred or Delivered. Intermountain may require Contractor to transfer title and deliver to Intermountain, in the manner and to the extent directed by Intermountain:
- a. Any completed portion of the Work; and
 - b. Any partially completed portion of the Work and any parts, tools, dies, jigs, fixtures, drawings, information, and contract rights (hereinafter called "construction materials") as Contractor has specifically produced or specifically acquired for the performance of such part of this Contract as has been terminated; and Contractor will, upon direction of Intermountain, protect and preserve property in the possession of Contractor in which Intermountain has an interest.
- 12.2.4 Payment. When Intermountain terminates the Contract for one or more of the reasons stated in Paragraph 12.2.1, Intermountain may withhold payment and/or pursue all available remedies.
- 12.2.5 Intermountain Protection If Lienable. When the subject property is lienable, Intermountain may withhold from amounts otherwise due Contractor for such completed Work or construction materials such sum as Intermountain determines to be necessary to protect Intermountain against loss because of outstanding liens or claims for former lien holders.
- 12.2.6 Credits and Deficits. If the unpaid balance of the Contract Sum exceeds the full cost of finishing the Work, including compensation for A/E's services and expenses made necessary thereby, such excess will be paid to Contractor. If such cost exceeds the unpaid balance, Contractor will pay the difference to Intermountain this obligation for payment will survive the termination of the Contract.
- 12.2.7 If Contractor Found Not in Default or Excusable. If, after notice of termination of the Contract under the provisions of this Article, it is determined for any reason that Contractor was not in default under the provisions of this Article, or that the default was excusable under the provisions of this Article, the rights and obligations of the parties will be the same as if the notice of termination had been issued pursuant to the termination for convenience provisions.

- 12.2.8 Rights and Remedies Not Exclusive. The rights and remedies of Intermountain provided in this Article 12.2 will not be exclusive and are in addition to any other rights and remedies provided by law or under this Contract.

12.3 Suspension, Delay or Interruption of Work by Intermountain for Convenience.

- 12.3.1 By Intermountain in Writing. Intermountain may in writing and without cause, order Contractor to suspend, delay or interrupt the Work in whole or in part for such period of time as Intermountain may determine to be appropriate for the convenience of Intermountain.
- 12.3.2 Adjustments. Any adjustment in Contract Sum and Contract Time will be in accordance with Articles 3, 4, and 7.

12.4 Termination for Convenience of Intermountain.

- 12.4.1 In General. The performance of Work under this Contract may be terminated by Intermountain in accordance with this Article 12.4 in whole, or from time to time, in part, whenever Intermountain will determine that such termination is in the best interest of Intermountain or any person for whom Intermountain is acting under this Contract. Any such termination will be effected by delivery to Contractor of a notice of termination specifying the extent to which performance of Work under the Contract is terminated, and the date upon which such termination becomes effective.
- 12.4.2 Contractor Obligations. After receipt of a notice of termination, and except as otherwise directed by Intermountain in writing, Contractor will:
- a. Stop work under the Contract on the date and to the extent specified in the notice of termination;
 - b. Place no further orders or subcontracts for materials, services or facilities, except as may be necessary for completion of such portion of the Work under the Contract as is not terminated;
 - c. Terminate all orders and subcontracts to the extent that they relate to performance of Work terminated by the notice of termination;
 - d. Assign to Intermountain in the manner, at the times, and to the extent directed by Intermountain, all of the right, title and interest of Contractor under the orders and subcontracts so terminated, in which case Intermountain will have the right, in its discretion, to settle or pay any or all claims arising out of the termination of such orders and subcontracts;
 - e. Settle all outstanding liabilities and all claims arising out of such termination of orders and subcontracts, with the approval or ratification of Intermountain, which approval or ratification will be final for all the purposes of this Article 12.4;
 - f. Transfer title and deliver to Intermountain in the manner, at the times, and to the extent, if any, directed by Intermountain:
 - (i) The fabricated or unfabricated parts, work in process, completed work, supplies, and other material produced as a part of, or acquired in connection with the performance of the Work terminated by the notice of termination; and
 - (ii) The completed or partially completed drawings, information, and other property which, if the Contract had been completed, would have been required to be furnished to Intermountain;
 - g. Use best efforts to sell, in the manner, at the times, to the extent, and at the price or prices directed or authorized by Intermountain, any property of the types referred to in Paragraph 12.4.2.f above; provided, however, that Contractor:
 - (i) Will not be required to extend credit to any purchaser; and

- (ii) May acquire any such property under the conditions prescribed by and at a price or prices approved by Intermountain; and provided further that the proceeds of any such transfer of or disposition will be applied in reduction of any payments to be made by Intermountain to Contractor under this Contract or will otherwise be credited to the Contract Sum or paid in such other manner as Intermountain may direct;
 - h. Complete performance of such part of the Work as will not have been terminated by the notice of termination; and
 - i. Take such action as may be necessary, or as Intermountain may direct, for the protection and preservation of the property related to this Contract which is in the possession of Contractor in which Intermountain has or may acquire an interest.
- 12.4.3 Agreed Upon Payment. Subject to the provisions of Paragraph 12.4.2 above, Contractor and Intermountain may agree upon the amount to be paid to Contractor by reason of the total or partial termination of Work pursuant to this Article 12.4.
- 12.4.4 Payment Not Agreed Upon. In the event of the failure of Contractor and Intermountain to agree, as provided in Paragraph 12.4.3, upon the whole amount to be paid to Contractor by reason of the termination of Work pursuant to this Article 12.4, Intermountain will pay to Contractor the portion of the Contract Sum requisite with the portion of the Work completed as determined by Intermountain as of the date of termination, subject to offsets if any.
- 12.4.5 Deductions. In arriving at the amount due Contractor under this Article 12.4, there will be deducted:
- a. All unliquidated advance or other payments on account theretofore made to Contractor, applicable to the terminated portion of this Contract;
 - b. Any Claim which Intermountain may have against Contractor in connection with this Contract; and
 - c. The agreed price for, or the proceeds of sale of, any materials, supplies, or other things acquired by Contractor or sold, pursuant to the provisions of this Article 12.4, and not otherwise recovered by or credited to Intermountain.
- 12.4.6 Partial Payments. Intermountain may, from time to time, under such terms and conditions as it may prescribe, make partial payments and payments on account against cost incurred by Contractor in connection with the terminated portion of this Contract whenever, in the opinion of Intermountain the aggregate of such payments will be within the amount to which Contractor will be entitled hereunder. If the total of such payments is in excess of the amount finally agreed or determined to be due under this Article 12.4, such excess will be payable by Contractor to Intermountain upon demand, together with interest at a rate of five percent (5%) per annum for the period until the date such excess is repaid to Intermountain; provided, however, that no interest will be charged with respect to any such excess payment attributable to a reduction in Contractor's claim by reason of retention or other disposition of termination inventory until ten (10) Days after the date of such retention or disposition, or such later date as determined by Intermountain by reason of the circumstances.
- 12.4.7 Preserve and Make Available Records. Unless otherwise provided for in this Contract, or by applicable law, Contractor will, from the effective date of termination until the expiration of three years after final settlement under this Contract, preserve and make available to Intermountain at all reasonable times at the office of Contractor, but without direct charge to Intermountain, all books, records, documents and other evidence bearing on the costs and expenses of Contractor under this Contract and relating to the Work terminated hereunder, or, to the extent approved by Intermountain Representative, photographs, micrographs, or other authentic reproductions thereof.
- 12.4.8 Intermountain's Right to Stop the Work. If Contractor fails to correct Work or fails to carry out Work, as required by the Contract Documents or fails to comply with all required and customary safety

precautions; Intermountain, by written order signed personally or by an agent specifically so empowered by Intermountain in writing, may order Contractor to stop the Work, or any portion thereof, until the cause for such order has been eliminated; however, the right of Intermountain to stop the Work will not give rise to a duty on the part of Intermountain to exercise this right for the benefit of Contractor or any other person or entity.

END OF DOCUMENT

CONFIDENTIAL

**INTERMOUNTAIN HEALTHCARE
ACCESS AND CONFIDENTIALITY AGREEMENT**

SECTION 1.0 PURPOSE AND DEFINITION

- 1.1 **Purpose of this Agreement.** Federal and state laws, as well as Intermountain’s policies, protect Confidential Information, assure that it remains confidential, and permit it to be used for appropriate purposes. Those laws and policies assure that Confidential Information, which is sensitive and valuable, remains confidential. They also permit you to use Confidential Information only as necessary to accomplish legitimate and approved purposes. You need access to Confidential Information because you have one of the following roles:
- A. An Intermountain Workforce member, which includes volunteers (a “Workforce Member”);
 - B. An Intermountain-affiliated or Intermountain-credentialed Provider (a “Provider”); or
 - C. A vendor or agent of IHC Health Services, Inc. (a “Vendor” or “Agent”).
- 1.2 **Definition.** “Confidential Information” means data proprietary to Intermountain, other companies, or other persons, plus any other information that is private and sensitive and which Intermountain has a duty to protect. You may learn or access Confidential Information through oral communications, paper documents, computer systems, or through your activities at or with Intermountain. Examples of Confidential Information include the following information that is maintained by, or obtained from, Intermountain:
- A. An individual’s demographic, employment, or health information;
 - B. Peer-review information;
 - C. Intermountain’s business information, (e.g., financial and statistical records, strategic plans, internal reports, memos, contracts, peer review information, communications, proprietary computer programs, source code, proprietary technology, etc.); and
 - D. Intermountain’s or a Third-party’s information (e.g., computer programs, client and vendor proprietary information, source code, proprietary technology, etc.).

SECTION 2.0 YOUR DUTIES UNDER THIS AGREEMENT

- 2.1 **Principal Duties.** To qualify to access or use Confidential Information, you will comply with the laws and Intermountain policies governing Confidential Information. Your principal duties regarding Confidential Information include, but are not limited to, the following:
- A. Safeguard the privacy and security of Confidential Information;
 - B. Use Confidential Information only as needed to perform your legitimate and Intermountain-approved responsibilities. This means, among other things, that you will not:
 - (1) Access Confidential Information for which you have no legitimate need to know;
 - (2) Divulge, copy, release, sell, loan, revise, alter, or destroy any Confidential Information except as properly authorized within the scope of your legitimate and Intermountain-approved responsibilities; or
 - (3) Misuse Confidential Information;
 - C. Safeguard, and not disclose, your access code or any other authorization that allows you to access Confidential Information. This means, among other things, that you will:
 - (1) Accept responsibility for all activities undertaken using your access code and other authorization; and
 - (2) Report any suspicion or knowledge that you have that your access code, authorization, or any Confidential Information has been misused or disclosed without Intermountain’s permission (Report this suspicion or knowledge to the Intermountain Compliance Hotline at 1-800-442-4845, or, if you are a member of Intermountain’s Workforce, to your supervisor or facility compliance coordinator.);
 - D. Not remove Confidential Information from an Intermountain facility unless necessary for your legitimate and Intermountain-approved responsibilities (If removal of Confidential Information from an Intermountain facility is necessary, you will use reasonable and appropriate physical and technical safeguards—such as encrypting electronic Confidential Information.);
 - E. Report activities by any individual or entity that you suspect may compromise the confidentiality of Confidential Information (To the extent permitted by law, Intermountain will hold in confidence reports that are made in good faith about suspect activities, as well as the names of the individuals reporting the activities.);
 - F. Not use or share Confidential Information after termination of your role triggering the requirement to sign this Agreement (For example, if you are a Workforce Member, when you leave Intermountain’s employment; if you are a Provider, when you lose your privileges at an Intermountain facility or your privileges to access Confidential Information; and if you are a Vendor or Agent, when you finish your assignment or project with Intermountain or when your company stops doing business with Intermountain, whichever is first.); and
 - G. Claim no right or ownership interest in any Confidential Information referred to in this Agreement.

SECTION 3.0 VIOLATION OF DUTY – CHANGE OF STATUS

- 3.1 **Responsibility.** You are responsible for your noncompliance with this Agreement.
- 3.2 **Discipline.** If you violate any provision of this Agreement, you will be subject to discipline, including but not limited to, the following:
- A. If you are a Workforce Member, to dismissal as a member of Intermountain’s Workforce, loss of employment with Intermountain, termination of your ability to access Confidential Information, and legal liability;
 - B. If you are a Provider, a Vendor, or an Agent, to discipline, including revocation of your ability to access or use Confidential Information, and legal liability.
- 3.3 **Relief.** Any violation by you of any provision of this Agreement will cause irreparable injury to Intermountain that would not be adequately compensable in monetary damages alone or through other legal remedies, and will entitle Intermountain to the following:
- A. If you are a Workforce Member, or an Vendor or Agent, to preliminary and permanent injunctive relief, a temporary restraining order, and other equitable relief in addition to damages and other legal remedies; or
 - B. If you are a Provider, to a court order prohibiting your use of Confidential Information except as permitted by this Agreement, and Intermountain may also seek other remedies; and
- 3.4 **Authority.** Intermountain may terminate your access to Confidential Information if your status as a Workforce Member, Provider, Vendor, or Agent changes, if Intermountain determines that to be in the best interests of Intermountain’s mission, or if you violate any provision of this Agreement.

SECTION 4.0 Continuing Obligations. Your obligations under this Agreement continue after termination of your status as a Workforce Member, Provider, Vendor, or Agent.

Printed Name: _____

Signature: _____ Date: _____

THIS PAGE LEFT BLANK INTENTIONALLY



THIRD PARTY ACCESS REQUEST FORM

This form should be used to request third party access to approved Intermountain Healthcare Information Systems. Type the requested information in each section and obtain the required signatures. All request forms must be submitted to Cybersecurity at ISSA@imail.org. Failure to properly fill out this form completely and accurately may result in a delay in processing your request.

	Date
Company Name	Contact Name
Address (Street, City and State)	Zip Code
Primary phone number Other phone number	Email address

NOTE: The above stated company will notify Intermountain Healthcare and change any passwords or access codes into Intermountain's corporate computer systems upon the termination of the CONTACT NAME or other employees associated with the remote access process.

REQUESTOR INFORMATION

Name (Last, First, MI)	Date of Birth	Position Title
Preferred Name	Intermountain User ID	Intermountain Email Address
Primary Facility	US Based/Off Shore Facility	Office Phone Number
Department/Business Unit	Department Manager	Department Manager Email
Job Duties		
Justification for Access to Intermountain Systems		

ACCESS REQUEST:

***For Bulk Access Request, please see page 3

Required Access Period (check one) <input type="checkbox"/> Continuous <input type="checkbox"/> Limited period from dates _____ to _____	
Method of Access: <input type="checkbox"/> Secure Access – VPN Secure Access Group Name: _____ <input type="checkbox"/> Direct Access VDI VDI Pool: _____	
<input type="checkbox"/> Digipass Mobile Number (____)____-____ <input type="checkbox"/> Active Directory	
TYPE of access required (i.e., authority needed):	
SYSTEMS to be accessed (including Host IP Address, protocols and ports used, etc):	
NOTE: Before granting a User access to any system, the administrator is required to ensure the User exists in the Master User Directory, confirm the username, and if applicable, confirm the User's department.	
Does Intermountain have a signed Business Associated Agreement (BAA) with the 3rd Party? <div style="text-align: right;"> <input type="checkbox"/> Yes <input type="checkbox"/> No </div>	

Does Intermountain already have a support agreement with the appropriate confidentiality agreement signed and submitted?

Yes

No

INTERMOUNTAIN CONTACT:

Intermountain Healthcare Steward	John Ellis
Department	Facility Management
Facility	Central Office
Contact Phone(s)	(801) 442-3874

NOTE: The Intermountain steward is personally responsible for the access of the individual(s) on Intermountain systems. The Intermountain Steward will be listed as the manager for the individual(s) in the master directory.

ACKNOWLEDGEMENT and AGREEMENT:

Access to Intermountain Healthcare's computer systems is monitored and reviewed on a regular basis. Intermountain reserves the right to cancel access without notification to all entities at any time if it feels there's a possible security breach or risk that requires immediate disconnection. Further, all access to Intermountain's computer systems is bound to the current confidentiality and appropriate usage policies in effect.

As the Intermountain steward you are responsible for the access of the individual's listed on this form. The Intermountain steward is required to perform an annual review of all 3rd party access and attest that it is correct. As the Intermountain steward you are responsible for the removal of the user's access in when the 3rd party no longer requires access.

By signing this request, approvers affirm that the applicant's job duties meet the requirement for granting access to Intermountain Healthcare Information Systems and Data and agrees to immediately contact Cybersecurity if a) the applicant separates from the organization, b) the applicant's job duties no longer require access to specified systems, or c) there is any reason to revoke or modify the access granted through this request.

Vendor Contract Name

Vendor Contract Signature

John Ellis

Intermountain Healthcare Steward Name

Intermountain Healthcare Steward Signature

Date of Approval

FOR CYBERSECURITY USE ONLY:

Access approved?

YES

NO

If no, state reason for denial:

Security/Access Concerns:

Date Processed:

Processed By:



THIRD PARTY ACCESS REQUEST FORM

This form should be used to request third party access to approved Intermountain Healthcare Information Systems. Type the requested information in each section and obtain the required signatures. All request forms must be submitted to Cybersecurity at ISSA@imail.org. Failure to properly fill out this form completely and accurately may result in a delay in processing your request.

	Date
Company Name	Contact Name
Address (Street, City and State)	Zip Code
Primary phone number Other phone number	Email address

NOTE: The above stated company will notify Intermountain Healthcare and change any passwords or access codes into Intermountain's corporate computer systems upon the termination of the CONTACT NAME or other employees associated with the remote access process.

REQUESTOR INFORMATION

Name (Last, First, MI)	Date of Birth	Position Title
Preferred Name	Intermountain User ID	Intermountain Email Address
Primary Facility	US Based/Off Shore Facility	Office Phone Number
Department/Business Unit	Department Manager	Department Manager Email
Job Duties		
Justification for Access to Intermountain Systems		

ACCESS REQUEST:

***For Bulk Access Request, please see page 3

Required Access Period (check one) <input type="checkbox"/> Continuous <input type="checkbox"/> Limited period from dates _____ to _____
Method of Access: <input type="checkbox"/> Secure Access – VPN Secure Access Group Name: _____ <input type="checkbox"/> Digipass Mobile Number (____)____-____ <input type="checkbox"/> Direct Access VDI VDI Pool: _____ <input type="checkbox"/> Active Directory
TYPE of access required (i.e., authority needed):
SYSTEMS to be accessed (including Host IP Address, protocols and ports used, etc):
NOTE: Before granting a User access to any system, the administrator is required to ensure the User exists in the Master User Directory, confirm the username, and if applicable, confirm the User's department.
Does Intermountain have a signed Business Associated Agreement (BAA) with the 3rd Party? <div style="text-align: right;"> <input type="checkbox"/> Yes <input type="checkbox"/> No </div>

Does Intermountain already have a support agreement with the appropriate confidentiality agreement signed and submitted?

Yes

No

INTERMOUNTAIN CONTACT:

Intermountain Healthcare Steward	John Ellis
Department	Facility Management
Facility	Central Office
Contact Phone(s)	(801) 442-3874

NOTE: The Intermountain steward is personally responsible for the access of the individual(s) on Intermountain systems. The Intermountain Steward will be listed as the manager for the individual(s) in the master directory.

ACKNOWLEDGEMENT and AGREEMENT:

Access to Intermountain Healthcare's computer systems is monitored and reviewed on a regular basis. Intermountain reserves the right to cancel access without notification to all entities at any time if it feels there's a possible security breach or risk that requires immediate disconnection. Further, all access to Intermountain's computer systems is bound to the current confidentiality and appropriate usage policies in effect.

As the Intermountain steward you are responsible for the access of the individual's listed on this form. The Intermountain steward is required to perform an annual review of all 3rd party access and attest that it is correct. As the Intermountain steward you are responsible for the removal of the user's access in when the 3rd party no longer requires access.

By signing this request, approvers affirm that the applicant's job duties meet the requirement for granting access to Intermountain Healthcare Information Systems and Data and agrees to immediately contact Cybersecurity if a) the applicant separates from the organization, b) the applicant's job duties no longer require access to specified systems, or c) there is any reason to revoke or modify the access granted through this request.

Vendor Contract Name

Vendor Contract Signature

John Ellis

Intermountain Healthcare Steward Name

Intermountain Healthcare Steward Signature

Date of Approval

FOR CYBERSECURITY USE ONLY:

Access approved?

YES

NO

If no, state reason for denial:

Security/Access Concerns:

Date Processed:

Processed By:

3rd PARTY BULK ACCESS REQUEST FORM:

INTERMOUNTAIN CONTACT:

Intermountain Healthcare Steward	John Ellis
Department	Facility Management
Facility	Central Office
Contact Phone(s)	(801) 442-3874
NOTE: The Intermountain steward is personally responsible for the access of the individual(s) on Intermountain systems. The Intermountain Steward will be listed as the manager for the individual(s) in the master directory.	

REQUESTOR INFORMATION

Name (Last, First, MI)	Date of Birth	Position Title
Preferred Name	Intermountain User ID	Intermountain Email Address
Primary Facility	US Based/Off Shore Facility	Office Phone Number
Department/Business Unit	Department Manager	Department Manager Email

Job Duties

Justification for Access to Intermountain Systems

Name (Last, First, MI)	Date of Birth	Position Title
Preferred Name	Intermountain User ID	Intermountain Email Address
Primary Facility	US Based/Off Shore Facility	Office Phone Number
Department/Business Unit	Department Manager	Department Manager Email

Job Duties

Justification for Access to Intermountain Systems

Name (Last, First, MI)	Date of Birth	Position Title
Preferred Name	Intermountain User ID	Intermountain Email Address
Primary Facility	US Based/Off Shore Facility	Office Phone Number
Department/Business Unit	Department Manager	Department Manager Email

Job Duties

Justification for Access to Intermountain Systems

--

Name (Last, First, MI)	Date of Birth	Position Title
Preferred Name	Intermountain User ID	Intermountain Email Address
Primary Facility	US Based/Off Shore Facility	Office Phone Number
Department/Business Unit	Department Manager	Department Manager Email

Job Duties

Justification for Access to Intermountain Systems

Name (Last, First, MI)	Date of Birth	Position Title
Preferred Name	Intermountain User ID	Intermountain Email Address
Primary Facility	US Based/Off Shore Facility	Office Phone Number
Department/Business Unit	Department Manager	Department Manager Email

Job Duties

Justification for Access to Intermountain Systems

Name (Last, First, MI)	Date of Birth	Position Title
Preferred Name	Intermountain User ID	Intermountain Email Address
Primary Facility	US Based/Off Shore Facility	Office Phone Number
Department/Business Unit	Department Manager	Department Manager Email

Job Duties

Justification for Access to Intermountain Systems

Name (Last, First, MI)	Date of Birth	Position Title
Preferred Name	Intermountain User ID	Intermountain Email Address
Primary Facility	US Based/Off Shore Facility	Office Phone Number
Department/Business Unit	Department Manager	Department Manager Email

Job Duties

Justification for Access to Intermountain Systems

Name (Last, First, MI)	Date of Birth	Position Title
Preferred Name	Intermountain User ID	Intermountain Email Address
Primary Facility	US Based/Off Shore Facility	Office Phone Number
Department/Business Unit	Department Manager	Department Manager Email

Job Duties

Justification for Access to Intermountain Systems

Name (Last, First, MI)	Date of Birth	Position Title
Preferred Name	Intermountain User ID	Intermountain Email Address
Primary Facility	US Based/Off Shore Facility	Office Phone Number
Department/Business Unit	Department Manager	Department Manager Email

Job Duties

Justification for Access to Intermountain Systems

Name (Last, First, MI)	Date of Birth	Position Title
Preferred Name	Intermountain User ID	Intermountain Email Address
Primary Facility	US Based/Off Shore Facility	Office Phone Number
Department/Business Unit	Department Manager	Department Manager Email

Job Duties

Justification for Access to Intermountain Systems

Name (Last, First, MI)	Date of Birth	Position Title
Preferred Name	Intermountain User ID	Intermountain Email Address
Primary Facility	US Based/Off Shore Facility	Office Phone Number
Department/Business Unit	Department Manager	Department Manager Email

Job Duties

Justification for Access to Intermountain Systems

Name (Last, First, MI)	Date of Birth	Position Title
Preferred Name	Intermountain User ID	Intermountain Email Address
Primary Facility	US Based/Off Shore Facility	Office Phone Number
Department/Business Unit	Department Manager	Department Manager Email

Job Duties

Justification for Access to Intermountain Systems

Name (Last, First, MI)	Date of Birth	Position Title
Preferred Name	Intermountain User ID	Intermountain Email Address
Primary Facility	US Based/Off Shore Facility	Office Phone Number
Department/Business Unit	Department Manager	Department Manager Email

Job Duties

Justification for Access to Intermountain Systems

Name (Last, First, MI)	Date of Birth	Position Title
Preferred Name	Intermountain User ID	Intermountain Email Address
Primary Facility	US Based/Off Shore Facility	Office Phone Number
Department/Business Unit	Department Manager	Department Manager Email

Job Duties

Justification for Access to Intermountain Systems

Name (Last, First, MI)	Date of Birth	Position Title
Preferred Name	Intermountain User ID	Intermountain Email Address
Primary Facility	US Based/Off Shore Facility	Office Phone Number
Department/Business Unit	Department Manager	Department Manager Email

Job Duties

Justification for Access to Intermountain Systems

Name (Last, First, MI)	Date of Birth	Position Title
Preferred Name	Intermountain User ID	Intermountain Email Address
Primary Facility	US Based/Off Shore Facility	Office Phone Number
Department/Business Unit	Department Manager	Department Manager Email

Job Duties

Justification for Access to Intermountain Systems

Name (Last, First, MI)	Date of Birth	Position Title
Preferred Name	Intermountain User ID	Intermountain Email Address
Primary Facility	US Based/Off Shore Facility	Office Phone Number
Department/Business Unit	Department Manager	Department Manager Email

Job Duties

Justification for Access to Intermountain Systems

Name (Last, First, MI)	Date of Birth	Position Title
Preferred Name	Intermountain User ID	Intermountain Email Address
Primary Facility	US Based/Off Shore Facility	Office Phone Number
Department/Business Unit	Department Manager	Department Manager Email

Job Duties

Justification for Access to Intermountain Systems

Name (Last, First, MI)	Date of Birth	Position Title
Preferred Name	Intermountain User ID	Intermountain Email Address
Primary Facility	US Based/Off Shore Facility	Office Phone Number
Department/Business Unit	Department Manager	Department Manager Email

Job Duties

Justification for Access to Intermountain Systems

Name (Last, First, MI)	Date of Birth	Position Title
Preferred Name	Intermountain User ID	Intermountain Email Address
Primary Facility	US Based/Off Shore Facility	Office Phone Number
Department/Business Unit	Department Manager	Department Manager Email

Job Duties

Justification for Access to Intermountain Systems

Name (Last, First, MI)	Date of Birth	Position Title
Preferred Name	Intermountain User ID	Intermountain Email Address
Primary Facility	US Based/Off Shore Facility	Office Phone Number
Department/Business Unit	Department Manager	Department Manager Email

Job Duties

Justification for Access to Intermountain Systems

Name (Last, First, MI)	Date of Birth	Position Title
Preferred Name	Intermountain User ID	Intermountain Email Address
Primary Facility	US Based/Off Shore Facility	Office Phone Number
Department/Business Unit	Department Manager	Department Manager Email

Job Duties

Justification for Access to Intermountain Systems

Name (Last, First, MI)	Date of Birth	Position Title
Preferred Name	Intermountain User ID	Intermountain Email Address
Primary Facility	US Based/Off Shore Facility	Office Phone Number
Department/Business Unit	Department Manager	Department Manager Email

Job Duties

Justification for Access to Intermountain Systems

Name (Last, First, MI)	Date of Birth	Position Title
Preferred Name	Intermountain User ID	Intermountain Email Address
Primary Facility	US Based/Off Shore Facility	Office Phone Number
Department/Business Unit	Department Manager	Department Manager Email

Job Duties

Justification for Access to Intermountain Systems

Name (Last, First, MI)	Date of Birth	Position Title
Preferred Name	Intermountain User ID	Intermountain Email Address
Primary Facility	US Based/Off Shore Facility	Office Phone Number
Department/Business Unit	Department Manager	Department Manager Email

Job Duties

Justification for Access to Intermountain Systems

Name (Last, First, MI)	Date of Birth	Position Title
Preferred Name	Intermountain User ID	Intermountain Email Address
Primary Facility	US Based/Off Shore Facility	Office Phone Number
Department/Business Unit	Department Manager	Department Manager Email

Job Duties

Justification for Access to Intermountain Systems

Name (Last, First, MI)	Date of Birth	Position Title
Preferred Name	Intermountain User ID	Intermountain Email Address
Primary Facility	US Based/Off Shore Facility	Office Phone Number
Department/Business Unit	Department Manager	Department Manager Email

Job Duties

Justification for Access to Intermountain Systems

Name (Last, First, MI)	Date of Birth	Position Title
Preferred Name	Intermountain User ID	Intermountain Email Address
Primary Facility	US Based/Off Shore Facility	Office Phone Number
Department/Business Unit	Department Manager	Department Manager Email

Job Duties

Justification for Access to Intermountain Systems

Name (Last, First, MI)	Date of Birth	Position Title
Preferred Name	Intermountain User ID	Intermountain Email Address
Primary Facility	US Based/Off Shore Facility	Office Phone Number
Department/Business Unit	Department Manager	Department Manager Email

Job Duties

Justification for Access to Intermountain Systems

Name (Last, First, MI)	Date of Birth	Position Title
Preferred Name	Intermountain User ID	Intermountain Email Address
Primary Facility	US Based/Off Shore Facility	Office Phone Number
Department/Business Unit	Department Manager	Department Manager Email

Job Duties

Justification for Access to Intermountain Systems

Name (Last, First, MI)	Date of Birth	Position Title
Preferred Name	Intermountain User ID	Intermountain Email Address
Primary Facility	US Based/Off Shore Facility	Office Phone Number
Department/Business Unit	Department Manager	Department Manager Email

Job Duties

Justification for Access to Intermountain Systems

Name (Last, First, MI)	Date of Birth	Position Title
Preferred Name	Intermountain User ID	Intermountain Email Address
Primary Facility	US Based/Off Shore Facility	Office Phone Number
Department/Business Unit	Department Manager	Department Manager Email

Job Duties

Justification for Access to Intermountain Systems

Name (Last, First, MI)	Date of Birth	Position Title
Preferred Name	Intermountain User ID	Intermountain Email Address
Primary Facility	US Based/Off Shore Facility	Office Phone Number
Department/Business Unit	Department Manager	Department Manager Email

Job Duties

Justification for Access to Intermountain Systems

Name (Last, First, MI)	Date of Birth	Position Title
Preferred Name	Intermountain User ID	Intermountain Email Address
Primary Facility	US Based/Off Shore Facility	Office Phone Number
Department/Business Unit	Department Manager	Department Manager Email

Job Duties

Justification for Access to Intermountain Systems

Name (Last, First, MI)	Date of Birth	Position Title
Preferred Name	Intermountain User ID	Intermountain Email Address
Primary Facility	US Based/Off Shore Facility	Office Phone Number
Department/Business Unit	Department Manager	Department Manager Email

Job Duties

Justification for Access to Intermountain Systems

Name (Last, First, MI)	Date of Birth	Position Title
Preferred Name	Intermountain User ID	Intermountain Email Address
Primary Facility	US Based/Off Shore Facility	Office Phone Number
Department/Business Unit	Department Manager	Department Manager Email
Job Duties		
Justification for Access to Intermountain Systems		
Name (Last, First, MI)	Date of Birth	Position Title
Preferred Name	Intermountain User ID	Intermountain Email Address
Primary Facility	US Based/Off Shore Facility	Office Phone Number
Department/Business Unit	Department Manager	Department Manager Email
Job Duties		
Justification for Access to Intermountain Systems		
Name (Last, First, MI)	Date of Birth	Position Title
Preferred Name	Intermountain User ID	Intermountain Email Address
Primary Facility	US Based/Off Shore Facility	Office Phone Number
Department/Business Unit	Department Manager	Department Manager Email
Job Duties		
Justification for Access to Intermountain Systems		
Name (Last, First, MI)	Date of Birth	Position Title
Preferred Name	Intermountain User ID	Intermountain Email Address
Primary Facility	US Based/Off Shore Facility	Office Phone Number
Department/Business Unit	Department Manager	Department Manager Email
Job Duties		
Justification for Access to Intermountain Systems		

Name (Last, First, MI)	Date of Birth	Position Title
Preferred Name	Intermountain User ID	Intermountain Email Address
Primary Facility	US Based/Off Shore Facility	Office Phone Number
Department/Business Unit	Department Manager	Department Manager Email

Job Duties

Justification for Access to Intermountain Systems

Name (Last, First, MI)	Date of Birth	Position Title
Preferred Name	Intermountain User ID	Intermountain Email Address
Primary Facility	US Based/Off Shore Facility	Office Phone Number
Department/Business Unit	Department Manager	Department Manager Email

Job Duties

Justification for Access to Intermountain Systems

Name (Last, First, MI)	Date of Birth	Position Title
Preferred Name	Intermountain User ID	Intermountain Email Address
Primary Facility	US Based/Off Shore Facility	Office Phone Number
Department/Business Unit	Department Manager	Department Manager Email

Job Duties

Justification for Access to Intermountain Systems

Name (Last, First, MI)	Date of Birth	Position Title
Preferred Name	Intermountain User ID	Intermountain Email Address
Primary Facility	US Based/Off Shore Facility	Office Phone Number
Department/Business Unit	Department Manager	Department Manager Email

Job Duties

Justification for Access to Intermountain Systems

Name (Last, First, MI)	Date of Birth	Position Title
Preferred Name	Intermountain User ID	Intermountain Email Address
Primary Facility	US Based/Off Shore Facility	Office Phone Number
Department/Business Unit	Department Manager	Department Manager Email
Job Duties		
Justification for Access to Intermountain Systems		
Name (Last, First, MI)	Date of Birth	Position Title
Preferred Name	Intermountain User ID	Intermountain Email Address
Primary Facility	US Based/Off Shore Facility	Office Phone Number
Department/Business Unit	Department Manager	Department Manager Email
Job Duties		
Justification for Access to Intermountain Systems		
Name (Last, First, MI)	Date of Birth	Position Title
Preferred Name	Intermountain User ID	Intermountain Email Address
Primary Facility	US Based/Off Shore Facility	Office Phone Number
Department/Business Unit	Department Manager	Department Manager Email
Job Duties		
Justification for Access to Intermountain Systems		
Name (Last, First, MI)	Date of Birth	Position Title
Preferred Name	Intermountain User ID	Intermountain Email Address
Primary Facility	US Based/Off Shore Facility	Office Phone Number
Department/Business Unit	Department Manager	Department Manager Email
Job Duties		
Justification for Access to Intermountain Systems		

Above Ceiling Work Permit

**Standards Referenced: NFPA 101 2012; NFPA 30 2012; NFPA 45 2011; NFPA 99 2012

Facility Name:
Requestor Name:
Company/Dept:
Contact Phone:

Permit No.:
Project No.:
Work/PO No.:

Start Date: Start Time:
End Date: End Time:

Exact Location of Work:

Description of Work:

Will ANY penetrations be made in walls, roof, floor or ceilings? Yes No

Will wiring or data cabling be installed or modified? Yes No

Type of Wiring

Communication
 Door Control
 Low or High Voltage Electrical
 Fiber Optic
 Fire Alarm

HVAC
 Security
 Telephone
 Television
 Other -

Will fixtures, appliances, duct work or equipment be installed? Yes No

How will the work be supported?

Fastened to deck or structure
 Fastened to wall
 Existing cable tray
 Existing pipe rack or conduit rack

New cable tray
 New pipe rack or conduit rack
 Other -

Intermountain Point of Contact: POC Phone:
Print Name Clearly

Site Pre-Inspection

Intermountain Representative: Requestor:
Print Name Clearly Print Name Clearly

Notes or Observations (if any):

Site Post-Inspection

Intermountain Representative: Requestor:
Print Name Clearly Print Name Clearly

No unsealed penetrations observed All installations properly supported

Notes or Observations (if any):

Intermountain Review and Approval of Work

Intermountain Representative: Date:
Signature

Why do we have to do this?

Because more people die of smoke inhalation in fires than die of fires in fires.
Because 6% of all TJC findings at Intermountain are penetrations in smoke or fire barriers.

THIS PAGE LEFT BLANK INTENTIONALLY

Hot Work Permit



Facility Name:

Requestor Name:

Company/Dept:

Contact Phone:

Permit No.:

Project No.:

Start Date:

End Date:

Work / PO No.:

Start Time:

End Time:

Exact Location of Work:

Description of Work:

Heat Sources

- Gas Torch Grinder Arc Welder Drill Chemical
 Other -

Will work require disabling fire detection or suppression systems? Yes No

Will systems be disabled longer than 4 hours in any 24 hours? Yes No

Will work generate smoke, odors or fumes? Yes No

Establishing The Work Area

- | | |
|--|--|
| <input type="checkbox"/> 35' space clear of combustibles | <input type="checkbox"/> Appropriate fire extinguishers on hand |
| <input type="checkbox"/> Fire blankets or protective mats in place | <input type="checkbox"/> Confined space permit on hand or not needed |
| <input type="checkbox"/> Space is well-ventilated | <input type="checkbox"/> Atmosphere tested non-explosive |
| <input type="checkbox"/> Signage and barricades in place | <input type="checkbox"/> Welding shields are in place as needed |
| <input type="checkbox"/> Safety observer on hand | <input type="checkbox"/> Fire watch arranged for |
| <input type="checkbox"/> Other precautions: <input type="text"/> | |

Intermountain Point of Contact: POC Phone:

Emergency Phone Number:

Upon Conclusion of Work

Name of Fire Watch Personnel: Supervisor:

- Fire watch was kept for 60 minutes after hot work was complete
 No sign of smoke or fire was detected during fire watch

Notes or Observations (if any):

Intermountain Review and Approval of Work

Intermountain Point of Contact: Date:

Why do we have to do this?

- Because more people die of smoke inhalation in fires than die of fires in fires.
- Because 6% of all TJC findings at Intermountain are penetrations in smoke or fire barriers.

THIS PAGE LEFT BLANK INTENTIONALLY

PeopleSoft Project # or Job Name:	
-----------------------------------	--

Infection Control Risk Assessment (ICRA)



Work Permit

20190416

Facility or Location

Project Start Date:

Contractor Project Manager:

Estimated Completion Date:

Contractor Performing Work:

Need to Relocate Patients?
<input type="radio"/> Yes <input type="radio"/> No

Affected Department Supervisor Signature:	
	Name: <input type="text"/>
	Date: <input type="text"/>

Environmental Service Supervisor Signature:	
	Name: <input type="text"/>
	Date: <input type="text"/>

Intermnt Hlthcare Project Manager Signature:	
	Name: <input type="text"/>
	Date: <input type="text"/>

Construction Activity Class (Determine Class by using the Classification Table on pages 2 & 3):			
Higher levels must include all lower levels. Example: a level III must also check I and II.			
<input type="checkbox"/> Class I	<input type="checkbox"/> Class II	<input type="checkbox"/> Class III	<input type="checkbox"/> Class IV

Specific Areas to be Affected by This Work:	
Initials: <input type="text"/>	Date: <input type="text"/>

Exceptions or Additions to This Permit:	
Initials: <input type="text"/>	Date: <input type="text"/>

Signature of Permit Requested by:	
	Name: <input type="text"/>
	Date: <input type="text"/>

Infection Prevention Approval Signature:	
	Name: <input type="text"/>
	Date: <input type="text"/>

PeopleSoft Project # or Job Name:

Construction Activity Class Worksheet

Complete Steps 1 through 3, then see Step 4.

STEP 1. Determine Construction Activity Type:

- Type A: **Inspection and non-invasive activities**
Includes, but not limited to:
- window replacement.
 - ceiling tile replacement limited to 1 tile per 50 sf.
 - painting or wall covering, without sanding
 - finish electrical and minor plumbing work
- Type B: **Small scale, short duration activities that create minimal dust and disruption to patient population via noise, vibration, odors or ventilation systems**
Includes, but not limited to:
- installing telephone or computer cabling or access to chase or mechanical spaces
 - patch or replace vinyl and/or carpet floors
 - cutting walls or ceilings where dust migration can be controlled
- Type C: **Generates moderate or high levels of dust. Demolition or removal of ANY fixed building components or assemblies. Disruption to patients with noise, vibration, HVAC systems etc.**
Includes, but not limited to:
- sanding walls to remove paint or wall coverings
 - removal of floor coverings, ceiling tiles or casework
 - new wall construction, major cabling activities, or adding new floor
- Type D: **Major demolition or construction that creates major disruption, i.e. noise, dust, vibration, odor, or mechanical systems**
Includes, but not limited to:
- new construction or buildout of shelled space
 - heavy demolition. Removal of a complete cabling system, floor, wall or ceiling

STEP 2. Determine Infection Control Risk Group:

- Lowest
- Office areas
 - Admitting
 - Meeting rooms
 - Education centers
 - Copy centers
 - Fitness centers
 - Gift shops
 - Mail rooms
 - Plant engineering
 - EVS
 - Non-patient areas
 - Low risk areas not listed elsewhere
- Medium
- Cardiology
 - Resp. Therapy
 - Echocardiography
 - Radiology/MRI
 - Endoscopy
 - Physical therapy
 - Nuclear medicine
 - Wound Clinics
 - Outpatient Clinics
 - Laundry
 - Cafeteria/Foods
 - PT/OT/Speech
 - Materials Mgmt.
- High
- Acute Care Floors
 - Surgical Units
 - Emergency Dept.
 - Post Anesthesia CU
 - L&D
 - Pharmacy
 - Lab and specimens
 - Pediatrics
 - Medical Units
 - Outpatient Surg.
 - Newborn Nursery
 - Infusion Clinic
 - Dialysis
- Highest
- Burn Unit
 - Oncology or any immunocomp pts.
 - Catheter Labs
 - Cent Sterile Supply
 - Intensive Care Unit
 - Pos. Pressure Rm.
 - Angiography Rm.
 - Pharm compound areas
 - Level 3 Lab area
 - Micro Lab
 - Invasive proceed
 - OR & C-Section Rm

PeopleSoft Project # or Job Name:

STEP 3. Use the classifications from STEP 1 and 2 to determine the Construction Class below:

Higher classes include lower classes as well. Example, III includes I, II, & III.

Construction Activity Type*





Patient Risk	Type A	Type B	Type C	Type D
Lowest	Class I	Class I	Class I	Class III
Medium	Class II	Class II	Class III	Class IV
High	Class II	Class III	Class IV	Class IV
Highest	Class III	Class III	Class IV	Class IV





*Infection Control Approval is needed for all projects

4. Follow all the appropriate Infection Control Protocols below: (Hand hygiene stations must be available)

During Construction

Upon Completion

 Class I	<ul style="list-style-type: none"> - Perform work using methods to minimize raising dust or tracking dust into other areas. - Immediately replace ceiling tile upon completion of inspection. 	<ul style="list-style-type: none"> - Clean work area.
 Class II	<ul style="list-style-type: none"> - All measures for Class I work. - Use active dust control measures. - Use water mist to control dust while cutting. - Seal doors, ducts, vents and HVAC units. - Place dust control mats at entries to work area; keep them clean and effective. - Remove debris only in tightly covered containers. 	<ul style="list-style-type: none"> - All measures for Class I work. - Wipe all horizontal surfaces with disinfectant. - Remove debris only in tightly covered containers. - Vacuum using HEPA filtered vacuum; mop with disinfectant as appropriate. - Remove all seals from doors, ducts, vents and HVAC units.
 Class III	<ul style="list-style-type: none"> - All measures for Class II work. - Construct barriers to prevent dust and other contaminant migration prior to beginning work. - Maintain negative air pressure in work space using HEPA filtration units. 	<ul style="list-style-type: none"> - All measures for Class II work. - Remove construction barriers only after all needed inspections are complete and passed. - Remove construction barriers in a manner that minimizes the spread of dust and debris. - Use HEPA Filter vacuum on clothes.
 Class IV	<ul style="list-style-type: none"> - All measures for Class III work. - Seal all pipes, conduits and penetrations. 	<ul style="list-style-type: none"> - All measures for Class III work.

-  **Non-construction visitors wear shoe covers when VISITING construction area**
-  **Construction workers wear shoe covers when Leaving the construction area**
-  **Provide Neg Pressure Air Monitoring Log During Construction**
-  **Construct anteroom outside area of construction**
-  **Workers to wear clean paper overalls and shoe covers when entering/exiting site**

PeopleSoft Project # or Job Name: _____

Additional Requirements For This Area:

Initials: _____ Date: _____

Other Considerations for Work Impact

1. Identify the risk levels of areas that are adjacent to the project:

Above				Below				Lateral				Lateral				Front				Other							
<input type="checkbox"/>	<input type="checkbox"/>	<input type="checkbox"/>	<input type="checkbox"/>	<input type="checkbox"/>	<input type="checkbox"/>	<input type="checkbox"/>	<input type="checkbox"/>	<input type="checkbox"/>	<input type="checkbox"/>	<input type="checkbox"/>	<input type="checkbox"/>	<input type="checkbox"/>	<input type="checkbox"/>	<input type="checkbox"/>	<input type="checkbox"/>	<input type="checkbox"/>	<input type="checkbox"/>	<input type="checkbox"/>	<input type="checkbox"/>	<input type="checkbox"/>	<input type="checkbox"/>	<input type="checkbox"/>	<input type="checkbox"/>	<input type="checkbox"/>	<input type="checkbox"/>	<input type="checkbox"/>	<input type="checkbox"/>
Lowest	Medium	High	Highest	Lowest	Medium	High	Highest	Lowest	Medium	High	Highest	Lowest	Medium	High	Highest	Lowest	Medium	High	Highest	Lowest	Medium	High	Highest	Lowest	Medium	High	Highest

2. Identify likely outages and their effects: plumbing, medical gas, ventilation, electrical, etc.:

3. Describe specific containment measures to be used:

4. Describe specific risks associated with water damage:

5. Describe noise and vibrations that will impact patient care areas and how you will mitigate that:

6. Identify the project work hours - avoiding patient care impact when possible:

- 7. Do plans allow for sufficient isolation/negative airflow rooms? Yes No N/A
- 8. Do plans allow for sufficient hand washing sinks per AIA guidelines? Yes No N/A
- 9. Do plans allow for sufficient access to clean and soiled utility rooms? Yes No N/A

PeopleSoft Project # or Job Name:

10. Describe the Project Communication Plan for traffic patterns, EVS, etc.:

--

11. Describe the Project Monitoring Plan for infection control, safety, etc.:

--

12. Project Closeout (See last page for on-going review form)

Signature for project closure, final review and approval for using the area:

(Facility Maintenance for Class I & II, Infection Prevention for Class III & IV)

--

Name:

--

Date:

--

PeopleSoft Project # or Job Name:

File Upload - A PDF image or PDF form can be uploaded. Only the most recent upload will show.

A large, empty yellow rectangular area with a black border, intended for file upload. It occupies the majority of the page's vertical space below the header and instructions.

THIS PAGE LEFT BLANK INTENTIONALLY



Intermountain Healthcare

Facilities Management

Interim Life Safety Measures Work Permit

PeopleSoft Project # or Job Name:

Project Start Date:

Project Manager:

Estimated Completion Date:

Contractor Performing Work:

Need to Relocate Patients?

Yes No

Affected Department Supervisor Signature:

Date Signed:

Environmental Services Supervisor Signature:

Date Signed:

Environment of Care Manager Signature:

Date Signed:

Affected Life Safety Systems

Fire Detection
 Fire Suppression
 Fire or Smoke Barriers
 Egress

Specific Areas to be Affected by This Work:

Initials:

Date:

Exceptions or Additions to This Permit:

Initials:

Date:

Request and Approval:

Permit Request By:

Printed Name:

Permit Approved By:

Printed Name:

Signature:

Signature:

Date:

Date:

Fire Detection, Suppression and Barrier Systems

Yes No

- Will individual smoke or heat detectors be out of service longer than 4 hours?
- Will fire alarm panel be out of service or in "test" mode longer than 4 hours?
- Will fire alarm circuits be out of service longer than 4 hours?
- Will fire alarm communication lines be out of service longer than 4 hours?

If "yes" to any of the above, detail the interim life safety measures to be taken below:

Yes No

- Will covers be placed on any smoke or heat detectors?

If "yes" list the devices to be covered and when the covers will be removed:

On conclusion of work, check box to indicate that all covers have been removed.

Yes No

- Will any component of the suppression system be out of service longer than 4 hours?

If "yes," detail the interim life safety measures to be taken below:

Yes No NA

- Will any floor, wall or ceiling be penetrated?
- If "yes" above, is the floor, wall or ceiling a rated assembly?

If "yes," detail the interim life safety measures to be taken below:

Egress Integrity

Yes No

- Will any portion of the work obstruct a means of egress?
- Will any portion of the work alter a means of egress?
- Will any portion of the work obstruct, impair or remove egress signage?
- Will any portion of the work obstruct, impair or remove egress lighting?

If "yes," detail the interim life safety measures to be taken below:

Maintaining a Safe Work Environment

Yes

No

Will a Hot Work Permit be needed?

Will a Confined Space Entry Permit be needed?

Will an Above Ceiling Work Permit be needed?

Will air quality monitoring be required on site?

Workplace Safety Guidelines

Access to the work site is restricted to authorized personnel only.

All personnel wear appropriate PPE while on site.

All personnel have had a site safety briefing and know where emergency services are located.

Tobacco use is strictly prohibited on the work site.

Chemical safety data sheets and safety stations are available to all personnel on site.

The work site is maintained in a clean and orderly state at all times.

All tools are unplugged and power turned off at the end of each work day.

All tools, including extension cords and ladders are in safe operating condition.

Any temporary structures or partitions are built smoke tight and of non-combustible materials.

Intermountain Healthcare is notified of any fire system shut down before work begins.

Workplace Safety Guidelines for Long-Duration Projects

Fire alarm and temporary suppression systems will be tested monthly.

At least 1 fire drill will be conducted per shift per month.

Describe the Project Communication Plan for traffic patterns, EVS, etc.:

Describe the Project Monitoring Plan for life safety measures:

THIS PAGE LEFT BLANK INTENTIONALLY

DIVISION 01 – GENERAL REQUIREMENTS

Section 01 1100	Summary of Work
Section 01 1101	Preconstruction Responsibility Matrix
Section 01 1900	Definitions and Standards
Section 01 2600	Contract Modification Procedures
Section 01 2900	Payment Procedures
Section 01 3100	Project Management and Coordination
Section 01 3300	Submittal Procedures
Section 01 5000	Temporary Facilities and Controls
Section 01 6000	Product Requirements
Section 01 7300	Execution
Section 01 7301	Pre-Construction Safety Requirements
Section 01 7329	Cutting and Patching
Section 01 7700	Closeout Procedures
Section 01 7701	Record Drawing Requirements

THIS PAGE LEFT BLANK INTENTIONALLY

SECTION 01 1100

SUMMARY OF WORK

PART 1 - GENERAL

1.1 SUMMARY

- A. Requirements of Division 00 "Procurement and Contracting Requirements" and Division 01 "General Requirements" apply to every section contained in the Project Manual, and shall govern the execution of Work required by the Contract Documents.
- B. Provide everything necessary for and incidental to proper and satisfactory completion of all Work specified and indicated or shown in the Contract Documents.
- C. The Project consists of **renovations** to Intermountain Healthcare Riverton Hospital Ambulatory Surgery Center.

1.2 PROJECT LOCATION

- A. **Project Site:** Intermountain Riverton Hospital, 3741 W 12600 S, Riverton, Utah 84065.

1.3 SEPARATE CONTRACTS

- A. **Owner may enter into multiple contracts for construction.** Each subcontractor shall be responsible to coordinate efforts with other trade contractors to ensure timely completion of the Work.
- B. **Coordinate the Work** of this Contract with the work of separate contractors to ensure timely completion of the work.

1.4 CODES

- A. **Law of place of building governs.** Conform to applicable requirements of the latest editions, including but not limited to the International Building Code, International Building Code Standards, International Mechanical Code, International Plumbing Code, National Electrical Code, National Fire Protection Association requirements, local ordinances, OSHA, and all other applicable code requirements, unless a higher standard is called for, without additional cost to the Owner.
- B. **Comply with CABO/ANSI A117.1**, American National Standard, "Accessible and Usable Buildings and Facilities" latest edition, which is in force for the project location, for handicapped accessibility.

1.5 CONTRACTOR USE OF PREMISES

- A. **General:** During the construction period, the Contractor shall have limited use of the premises for construction operations, including:
1. The Contractor's use of the premises is limited by the Owner's right to conduct business as usual in occupied portions of the building, perform work or to retain other contractors on portions of the Project.
- B. **Use of the Site:** Limit use of the premises to work in areas indicated. Confine operations to areas within contract limits indicated. Do not disturb portions of the site beyond the areas in which the Work is indicated.
1. **Driveways and Entrances:** Keep driveways and entrances serving the premises clear and available to the Owner and Owner's employees and emergency vehicles at all times. Do not use these areas for parking or storage of materials. Schedule deliveries to minimize space and time requirements for storage of materials and equipment on-site.
 2. Do not unreasonably encumber the site with materials or equipment. Confine stockpiling of materials and location of storage sheds to the areas indicated. If additional storage is necessary obtain and pay for such storage off-site.
 3. Lock automotive type vehicles such as passenger cars and trucks and other types of mechanized and motorized construction equipment, when parked and unattended, so as to prevent unauthorized use. Do not leave such vehicles or equipment unattended with the motor running or the ignition key in place.

1.6 OWNER'S OCCUPANCY REQUIREMENTS

- A. **Partial Owner Occupancy:** Owner will occupy the premises during entire construction period, with the exception of areas under construction. Cooperate with Owner during construction operations to minimize conflicts and facilitate Owner usage. Perform the Work so as not to interfere with Owner's operations. Maintain existing exits, unless otherwise indicated.
1. Maintain access to existing walkways, corridors, and other adjacent occupied or used facilities. Do not close or obstruct walkways, corridors, or other occupied or used facilities without written permission from Owner and authorities having jurisdiction.
 2. Provide not less than 72 hours' notice to Owner of activities that will affect Owner's operations.
- B. **Owner Access to Completed Areas of Construction:** Owner reserves the right to place and install equipment in completed areas of building, before Substantial Completion, provided such placement does not interfere with completion of the Work. Such placement of equipment shall not constitute acceptance of the total Work.
1. On occupancy, Owner will assume responsibility for maintenance and custodial service for occupied portions of building.

1.7 WORK RESTRICTIONS

- A. **On-Site Work Hours:** Work shall be generally performed inside the existing building during normal business working hours of 7:30 a.m. to 7:00 p.m., Monday through Friday, and 9:00 a.m. to 6:00 p.m. Saturday, except otherwise indicated.
1. **Weekend Hours:** Contractor shall not work on Sundays.
 2. **Hours for Utility Shutdowns:** Shall not occur during Owner's business hours.
 3. **Hours for Core Drilling and Slab Removal:** Consult with Owner as to best times. Work shall be scheduled with Owner not less than 24 hours in advance of proposed noisy activity.

- B. **Existing Utility Interruptions:** Do not interrupt utilities serving facilities occupied by Owner or others unless permitted under the following conditions and then only after arranging to provide temporary utility services according to requirements indicated:
1. Notify Architect and Owner not less than two days in advance of proposed utility interruptions.
 2. Do not proceed with utility interruptions without Architect's written permission.

1.8 INCIDENTAL WORK

- A. **Any work**, materials or equipment that may reasonably be inferred from the Contract Documents as being required to produce the intended result shall be supplied by the Contractor at no additional cost to the owner whether or not specifically called for in the Contract Documents.

PART 2 - PRODUCTS - NOT USED

PART 3 - EXECUTION - NOT USED

END OF SECTION

THIS PAGE LEFT BLANK INTENTIONALLY

RESPONSIBILITY MATRIX

Updated June 7, 2019

The following list identifies the majority of the items that are to be included in the capital project build-out. All Owner items need to be coordinated with A/E (Design Team), Contractor and Owner (Facility Design & Construction and Supply Chain Equipment Planners). For OFOI or OFCI items, Contractor is required to track equipment on construction schedule and to notify Owner of required delivery times taking into account for equipment lead times.

ITEM	OWNER/VENDOR	NOTES	ADDITIONAL NOTES		
			Data	Power	Backlog
OFOI - (Owner Furnished / Owner Installed)					
(Coordinate location of items with Owner and track within construction schedule)					
Art	Owner / Owner (Alpine Art)	All artwork to be coordinated with Dan Kohler. Provide power to required artwork.			
Brochure Racks	Owner / Owner	Contractor to provide proper backing.			
Chart Racks	Owner / Owner (Midwest)	Contractor to provide proper backing.			
Copiers, fax	Owner / Owner	A/E to locate where copy/fax/printer is not visual clutter.	Yes	Yes	
Cup Dispensers	Owner / Owner				
Exam Tables	Owner / Owner			Yes	
Systems Furniture (including demountable partitions)	Owner / Owner (Midwest & Steelcase)	Coordinate modesty panels with elec. outlets. Sit/Stand desks to have modesty panel on front. Attention to be given to cord management. A/E to coordinate data and power with Midwest.	Yes	Yes	
Receptionist Desk	Owner / Owner (Midwest & Steelcase)				
Moveable Metal Shelving	Owner / Owner				
Recliners / Draw Chairs	Owner / Owner				
Signage - Exterior	Owner / Owner (IG Group, YESCO)	Provide power and data to required exterior signage. Provide circuits for above ceiling signs. Coordinate thru-wall conduit sleeves with weather barrier. A/E to coordinate traffic signage and Contractor to install. Intermountain Logo Signs - (2) 20A Circuits - May vary. InstaCare and other Signs - (1) 20 A Circuits - May vary.	Yes	Yes	Yes
Signage - Interior (including Code Signage)	Owner / Owner (Scribbley, Hightech)	Provide power to required signage. Contractor to track in schedule and notify Owner for when Code Required signage is required to be installed.			
Radiology Equipment	Owner / Owner (See subject matter expert list)	A/E responsible to coordinate final site equipment drawings into Construction Documents from Owner's Vendor.	Yes	Yes	
Clinical Garbage Cans (Clinical, Office, PT, Etc.)	Owner / Owner				
Computers, Printers, Scanners, Keyboards, Mice, etc.	Owner / Owner	In-ceiling & wall mounts, conduits and boxes mounted by Contractor. Computers to be All-in-One, typ. in IMG exam rooms.	Yes	Yes	Yes
Televisions, Digital Projectors, similar devices, etc.	Owner / Owner	These items to be provided by Owner, but A/E to coordinate locations and infrastructure. Contractor to refer to OFCI section.	Yes	Yes	Yes
Keyboard Trays	Owner / Owner				
PACS	Owner / Owner				
Magnetic Marker Boards, Cork Boards, Huddle Boards, Idea Tracking Boards, etc.	Owner / Owner (Midwest)	A/E to coordinate location with Owner.			Yes
Emergency Evacuation Medical Sled (Med Sled)	Owner / Owner	A/E to coordinate location with Owner.			
Supply Area Panels	Owner / Owner	Contractor to provide proper backing, coordinate with Owner.			Yes
Audio/Video (A/V)	Owner / Owner	Intermountain SCO will source & supply the A/V system including specialized cabling (e.g. HDMI, etc). Refer to CFCL section for Contractor requirements. A/E to identify locations on drawings, coordinate with Owner. Contractor to provide infrastructure, back boxes, conduits, pathways and cabling (from wall side back).	Yes	Yes	
Nurse Notification Call (NNC) System & Devices (Hospital Campus)	Owner / Owner (Hill-Rom)	Hospital local facility team to work with Supply Chain Facility Equipment Planning team to contract directly with Nurse Notification Call (NNC) system vendor (Hill-Rom) for devices, equipment, monitors, etc. A/E to identify NNC locations on drawings, coordinate with Owner. Contractor to provide all infrastructure including conduits, back boxes, etc. for all NNC devices (e.g. RCB, GSR-10, etc.). The NNC system cabling will be by Hill-Rom including home-run cabling (Hill-Rom to coordinate, where required, with an Intermountain Siemon certified installer low voltage subcontractor to install home-run network connected cabling). The NNC system cabling device to device cabling is by Hill-Rom.	Yes	Yes	
Staff Assist Notification Call System & Devices (Medical Group Clinics on hospital campuses to match NNC system)	Owner / Owner (Hill-Rom)	Hospital local facility/IMG Ops team to work with Supply Chain Facility Equipment Planning team to contract directly with Staff Assist Notification Call system vendor (Hill-Rom) for devices, equipment, monitors, etc. (from wall side out). Staff Assist Notification system to be coordinated with Hospital Campus NNC system, as applicable, Medical Group Strategic Planner, and IMG Operations Officer. A/E to identify locations on drawings, coordinate with Owner. Contractor to provide all infrastructure including conduits, back boxes, etc. for all NNC and Staff Assist Notification Call devices (e.g. RCB, GSR-10, etc.). The NNC and Staff Assist Notification Call system cabling will be by Hill-Rom including home-run cabling (Hill-Rom to coordinate, where required, with an Intermountain Siemon certified installer low voltage subcontractor to install home-run network connected cabling). The NNC and Staff Assist Notification Call system device to device cabling is by Hill-Rom.	Yes	Yes	

Staff Assist Notification Call System & Devices (Stand-alone Medical Group Clinics)	Owner / Owner (Hill-Rom)	IMG Ops team to work with Supply Chain Facility Equipment Planning team to contract directly with Staff Assist Notification Call system vendor (Hill-Rom) for devices, equipment, monitors, etc. (from wall side out). Staff Assist Notification system to be coordinated with Medical Group Strategic Planner and Operations Officer. A/E to identify locations on drawings, coordinate with Owner. Contractor to provide all infrastructure including conduits, back boxes, etc. for all Staff Assist Notification Call devices (e.g. RCB, GSR-10, etc.). The Staff Assist Notification Call system cabling will be by Hill-Rom including home-run cabling (Hill-Rom to coordinate, where required, with an Intermountain Siemon certified installer low voltage subcontractor to install home-run network connected cabling). The Staff Assist Notification Call system device to device cabling is by Hill-Rom.	Yes	Yes	
Patient Monitoring System & Devices (Hospital Campus)	Owner / Owner	Hospital local facilities to work with Supply Chain Facility Equipment Planning team to contract directly with Patient Monitoring vendors for devices, equipment, monitors, etc. (from wall side out). A/E to identify locations on drawings, coordinate with Owner. Contractor to provide all infrastructure including conduits, back boxes, and home-run cabling from Patient Monitoring devices to TEC/TDR rooms that connect to Intermountain's network (Intermountain Siemon certified installer low voltage subcontractor to install). The Patient Monitoring system device to device cabling is by Vendor.	Yes	Yes	
IV Hangar	Owner / Owner	A/E to identify locations on drawings, coordinate with Owner. Backing to be coordinated, if required.			
Sharps Disposal Container	Owner / Owner (Stericycle)	A/E to identify locations on drawings, coordinate with Owner. Backing to be coordinated, if required.			
Infant/Pediatric Security System	Owner / Owner (Totguard)	A/E to identify locations on drawings. This system is to be coordinated with Owner, Women's and Children's Operations, Clinical Programs and Security.	Yes	Yes	
OFCI - (Owner Furnished / Contractor Installed) (Coordinate location of items with Owner and track within construction schedule)			Data	Power	Backing
Automated External Defibrillator (AED)	Owner / Contractor	A/E to identify locations on drawings, coordinate with Owner, A/E to coordinate recess, semi-recessed, or surface mount options with Owner.			Yes
Time Clocks	Owner / Contractor	Conduit and boxes by Contractor, Coordinate location with Owner.	Yes	Yes	
Paper Towel Dispensers	Owner / Contractor	A/E to identify locations on drawings, coordinate with Owner.			
Soap Dispensers	Owner / Contractor	A/E to identify locations on drawings, coordinate with Owner.			
Toilet Paper Dispensers	Owner / Contractor	A/E to identify locations on drawings, coordinate with Owner.			
Sanitary Napkin Dispensers/Receptacles	Owner / Contractor	A/E to identify locations on drawings, coordinate with Owner.			
Diaper Changing Station	Owner / Contractor	A/E to identify locations on drawings, coordinate with Owner.			Yes
Hand Sanitizer Dispensers (Avagard)	Owner / Contractor	A/E to identify locations on drawings, coordinate with Owner.			
Diagnostic Board (Otoscope / Ophthalmoscope)	Owner / Contractor	A/E to identify locations on drawings, coordinate with Owner.		Yes	
Stadiometers, Recessed Scales	Owner / Contractor	A/E to identify locations on drawings, coordinate with Owner; coordinate power.		Yes	
Procedure Lights	Owner / Contractor	A/E to coordinate with Owner and Owner's selected equipment Vendor; A/E to identify locations on drawings, coordinate with Owner; A/E to coordinate the design of the procedure light support structure into drawings. Contractor to provide and install procedure light support structure.		Yes	Yes
Scrub Sinks & Carriers	Owner / Contractor	A/E to identify locations on drawings, coordinate with Owner. Contractor to coordinate with Owner for ordering and for install coordination.			Yes
IV Track	Owner / Contractor	A/E to identify locations on drawings, coordinate with Owner. Backing to be coordinated, if required.			Yes
Boom Mounting Plates (Equipment, Lighting, Anesthesia)	Owner / Contractor	A/E to coordinate with Owner and Owner's selected equipment Vendor; A/E to identify boom locations on drawings, coordinate with Owner; A/E to coordinate the design of the boom support structure into drawings. Final site specific equipment drawings from Vendor to be coordinated with Construction Documents. Contractor to coordinate with Owner and install boom support structure and boom mounting plates. Contractor to coordinate with Owner for ordering and install of boom mounting plates.	Yes	Yes	Yes
OR Clocks	Owner / Contractor	A/E to identify locations on drawings, coordinate with Owner. Contractor to coordinate with Owner for ordering and install coordination.	Yes	Yes	Yes
Clinical Clocks	Owner / Contractor	A/E to identify locations on drawings, coordinate with Owner. Contractor to coordinate with Owner for ordering and install coordination.		Yes	Yes
Shower Curtains & Rods	Owner (Medline) / Contractor	A/E to identify locations on drawings, coordinate with Owner. Contractor to coordinate with Owner for ordering and install coordination.			
Cubicle Curtains & Tracks	Owner (Medline) / Contractor	A/E to identify locations on drawings, coordinate with Owner. Contractor to coordinate with Owner for ordering and install coordination.			
Digital Projector Mounts, TV Mounts, & Computer Mounts (Ergotron Brackets/Mounts, etc.)	Owner / Contractor	A/E to identify locations on drawings, coordinate with Owner. Contractor to coordinate with Owner for ordering and install coordination. In-ceiling & wall mounts, conduits and boxes provide and installed by Contractor A/E to coordinate A/V requirements. Contractor to pull required A/V cabling.	Yes	Yes	Yes
Radiation Protection Calculations and Certification	Owner / Contractor	A/E to coordinate with Owner in the design phase for coordinating with Medical Physicists Consultants or others, when required. Contractor to coordinate prior to Gyp. Bd. install.			Yes
Patient Lifts	Owner (Liko, subsidiary of Hill-Rom) / Contractor	A/E to identify locations on drawings, coordinate with Owner. A/E to design required support structure for Contractor to install for necessary Liko patient lift connections (e.g. pendant / rails / etc). Contractor to coordinate shop drawings and installation requirements prior with Liko. Connect to equipment branch if provided.		Yes	
Building Alarms / Medication Refrigerator Alarm / Pharmacy Alarm System	Owner / Contractor	A/E to identify locations and infrastructure on drawings, coordinate with Owner. Contractor to provide conduit and infrastructure into accessible ceiling for access from equipment and/or devices. Local Facility to contract with alarm company for alarm, wire, and monitoring.		Yes	

UPS (MRI, Data Room, CPU, or other similar equipment)	Owner / Contractor	A/E to identify equipment locations on drawings, coordinate with Owner.	Yes	Yes	Yes
iCentra Tracking Boards	Owner / Contractor	A/E to identify locations on drawings, coordinate with Owner.	Yes	Yes	Yes
Distributed Antenna System (DAS)	Owner (Hunt Electric) / Contractor	A/E to locate infrastructure on drawings to simplify the DAS install. Contractor to track on construction schedule and coordinate DAS install with Owner's Vendor.			
Alertus - Mass Notification System (Public Areas)	Owner (Alertus) / Contractor	A/E to identify locations on drawings, coordinate with Owner.	Yes	Yes	
CFCI - (Contractor Furnished / Contractor Installed)			Data	Power	Backing
Blinds/Shades (manual and powered)	Contractor / Contractor	A/E to identify locations on drawings, coordinate with Owner.		Yes	
Apron Hooks/Rack (Heavy Duty in Radiology)	Contractor / Contractor	A/E to identify locations on drawings, coordinate with Owner.			Yes
Communication Boards (e.g. Patient Rooms)	Contractor / Contractor	A/E to identify locations on drawings, coordinate with Owner.			Yes
Emergency Phones, Kiosks - Exterior	Contractor / Contractor	A/E to identify locations on drawings, coordinate with Owner. Conduit and boxes by Contractor.	Yes	Yes	Yes
Med Gas Certification	Contractor / Contractor	Contractor to coordinate Vendor with Owner			
Emergency Shower Station / Eye Wash Station	Contractor / Contractor	A/E to identify locations on drawings, coordinate with Owner. These shall meet ANSI and Owner requirements.			
Fire Extinguishers	Contractor / Contractor	A/E to identify types and locations on drawings, coordinate with Owner. 10 lbs. minimum - refer to Intermountain Design Guidelines & Construction Standards.			Yes
Grab Bars (Rest rooms, Radiology, Exam rooms, etc.)	Contractor / Contractor	A/E to identify locations on drawings.			Yes
Coat Hooks (Rest rooms/Showers, Exam rooms, Offices/Workstations only)	Contractor / Contractor	A/E to identify locations on drawings.			
Mirrors (Rest rooms, Exams, Radiology, Rehab, etc.)	Contractor / Contractor	A/E to identify locations on drawings, coordinate with Owner.			Yes
Pneumatic Tube Systems	Contractor / Contractor (SwissLog, Atreo Group, or other approved)	A/E to identify locations on drawings, coordinate with Owner. If SwissLog, verify pricing is per Intalere (Amerinet) Contract Agreement. Design assistance fees are included in this agreement.	Yes	Yes	
Plumbing Shrouds	Contractor / Contractor				
Security Cameras, Video Surveillance	Contractor / Contractor (AlphaCorp/Convergint)	A/E to identify locations on drawings, coordinate with Owner.	Yes		
Voice/Data Cabling (all horizontal cabling)	Contractor / Contractor (Cache Valley Elec., IES Commercial, Data Tech Professionals, Hunt Electric, and others listed in Intermountain Div. 27)	Refer to Division 27 in the Intermountain Design Guidelines and Construction Standards. Coordinate with Owner/User on connections, pairs of fiber/copper, conduits, inner-ducts, etc.	Yes		
Support Bracing/Structure for Radiology and similar equipment	Contractor / Contractor	A/E to coordinate with Owner and Owner's selected Radiology equipment Vendor; A/E to coordinate the design of the support bracing/structure into drawings. Final site specific equipment drawings from Vendor to be coordinated with Construction Documents. Contractor to coordinate with Owner for install of support structure.	Yes	Yes	Yes
Wall Protection (Incl. Bumper and Corner Guards)	Contractor / Contractor	A/E to identify locations on drawings, coordinate with Owner.			
Intrusion Detection	Contractor / Contractor	A/E to identify locations on drawings, coordinate with Owner.			
Access Control, Card Readers (Lenel)	Contractor / Contractor (AlphaCorp/Convergint)	A/E to identify locations on drawings, coordinate with Owner.			
Communication Cabling	Contractor / Contractor	A/E to identify locations on drawings, coordinate with Owner.			
TV System Distribution	Contractor / Contractor	A/E to identify locations on drawings, coordinate with Owner.			
Audio/Video (A/V)	Contractor / Contractor	Intermountain SCO will source & supply the A/V system including specialized cabling (e.g. HDMI, etc). A/E to identify locations on drawings, coordinate with Owner. Contractor to provide infrastructure, back boxes, conduits, pathways and misc. cabling (from wall side back).	Yes	Yes	
Nurse Notification Call (NNC) System - Low Voltage Cabling (Hospital Campus)	Contractor / Contractor (Hill-Rom)	A/E to identify NNC locations on drawings, coordinate with Owner. Contractor to provide all infrastructure including conduits, back boxes, etc. for all NNC devices (e.g. RCB, GSR-10, etc.). The NNC system cabling will be by Hill-Rom including home-run cabling (Hill-Rom to coordinate, where required, with an Intermountain Siemon certified installer low voltage subcontractor to install home-run network connected cabling). The NNC system cabling device to device cabling is by Hill-Rom.	Yes	Yes	
Staff Assist Notification Call System - Low Voltage Cabling (Medical Group Clinics on hospital campuses to match NNC system)	Contractor / Contractor (Hill-Rom)	A/E to identify locations on drawings, coordinate with Owner. Contractor to provide all infrastructure including conduits, back boxes, etc. for all NNC and Staff Assist Notification Call devices (e.g. RCB, GSR-10, etc.). The NNC and Staff Assist Notification Call system cabling will be by Hill-Rom including home-run cabling (Hill-Rom to coordinate, where required, with an Intermountain Siemon certified installer low voltage subcontractor to install home-run network connected cabling). The NNC and Staff Assist Notification Call system device to device cabling is by Hill-Rom.	Yes	Yes	
Staff Assist Notification Call System - Low Voltage Cabling (Stand-alone Medical Group Clinics)	Contractor / Contractor (Hill-Rom)	A/E to identify locations on drawings, coordinate with Owner. Contractor to provide all infrastructure including conduits, back boxes, etc. for all Staff Assist Notification Call devices (e.g. RCB, GSR-10, etc.). The Staff Assist Notification Call system cabling will be by Hill-Rom including home-run cabling (Hill-Rom to coordinate, where required, with an Intermountain Siemon certified installer low voltage subcontractor to install home-run network connected cabling). The Staff Assist Notification Call system device to device cabling is by Hill-Rom.	Yes	Yes	
Patient Monitoring System & Devices (Hospital Campus)	Contractor / Contractor	A/E to identify locations on drawings, coordinate with Owner. Contractor to provide all infrastructure including conduits, back boxes, and home-run cabling from Patient Monitoring devices to TEC/TDR rooms that connect to Intermountain's network (Intermountain Siemon certified installer low voltage subcontractor to install). The Patient Monitoring system device to device cabling is by Vendor.	Yes	Yes	

THIS PAGE LEFT BLANK INTENTIONALLY

SECTION 01 1900

DEFINITIONS AND STANDARDS

PART 1 - GENERAL

1.1 SUMMARY

- A. **Definitions:** Basic Contract definitions are included in the General Conditions.
1. **Directed:** Terms such as "directed", "requested", "authorized", "selected", "approved", "required", and "permitted" mean "directed by the Architect", "requested by the Architect", and similar phrases. However, no implied meaning shall be interpreted to extend the Architect's responsibility into the Contractor's area of construction supervision.
 2. **Approve:** The term "approved," where used in conjunction with the Architect's action on the Contractor's submittals, applications, and requests, is limited to the duties and responsibilities of the Architect as stated in General and Supplementary Conditions. Such approval shall not release the Contractor from responsibility to fulfill Contract requirements unless otherwise provided in the Contract Documents.
 3. **Furnish:** The term "furnish" is used to mean "supply and deliver to the Project site, ready for unloading, unpacking, assembly, installation, and similar operations."
 4. **Install:** The term "install" is used to describe operations at project site including the actual "unloading, unpacking, assembly, erection, placing, anchoring, applying, working to dimension, finishing, curing, protecting, cleaning, and similar operations."
 5. **Provide:** The term "provide" means "to furnish and install, complete and ready for the intended use."
 6. **Protect:** Except as otherwise defined in greater detail, the term "protect" is used to describe the process of shielding from harm existing fixtures, elements or materials.
 7. **Stabilize:** To apply measures designed to reestablish a weather-resistant enclosure and the structural reinforcement of an item or portion of the building while maintaining the essential form as it exists at present.
 8. **Protect and Maintain:** To remove deteriorating corrosion, reapply protective coatings, and install protective measures such as temporary guards; to provide the least degree of intervention.
 9. **Remove:** To detach items from existing construction and legally dispose of them off-site unless indicated to be removed and salvaged or removed and reinstalled.
 10. **Remove and Salvage:** To detach items from existing construction and deliver them to Owner ready for reuse.
 11. **Remove and Reinstall:** To detach items from existing construction, repair and clean them for reuse, and reinstall them where indicated.
 12. **Existing to Remain or Retain:** Existing items of construction that are not to be removed and that are not otherwise indicated to be removed and salvaged, or removed and reinstalled.
 13. **Existing to Remain:** Existing items of construction that are not to be removed and that are not otherwise indicated to be removed, removed and salvaged, or removed and reinstalled.

B. Specification Format and Conventions:

1. Specification Format: The Specifications are organized into Divisions and Sections using the 50-division format and CSI/CSC's "MasterFormat" numbering system.
 - a. Section Identification: The Specifications use section numbers and titles to help cross-referencing in the Contract Documents. Sections in the Project Manual are in numeric sequence; however, the sequence is incomplete. Consult the table of contents at the beginning of the Project Manual to determine numbers and names of sections in the Contract Documents.
2. Specification Content: The Specifications use certain conventions for style of language and the intended meaning of terms, words, and phrases when used in particular situations. These conventions are as follows.
 - a. Abbreviated Language: Language used in the Specifications and other Contract Documents is abbreviated. Words and meanings shall be interpreted as appropriate. Words implied, but not stated shall be inferred as the sense requires. Singular words shall be interpreted as plural, and plural words shall be interpreted as singular where applicable as the context of the Contract Documents indicates.
 - b. Imperative mood and streamlined language are generally used in the Specifications. Requirements expressed in the imperative mood are to be performed by Contractor. Occasionally, the indicative or subjunctive mood may be used in the Section Text for clarity to describe responsibilities that must be fulfilled indirectly by Contractor or by others when so noted.
 - 1) The words "shall", "shall be", or "shall comply with", depending on the context, are implied where a colon (:) is used within a sentence or phrase.

C. Drawing Symbols:

1. Graphic symbols: Where not otherwise noted, symbols are defined by "Architectural Graphic Standards", published by John Wiley & Sons, Inc., latest edition.
 - a. Mechanical/Electrical Drawings: Graphic symbols used on mechanical and electrical Drawings are generally aligned with symbols recommended by ASHRAE. Where appropriate, they are supplemented by more specific symbols recommended by technical associations including ASME, ASPE, IEEE, and similar organizations. Refer instances of uncertainty to the Architect for clarification before proceeding.

D. Industry Standards:

1. Applicability of Standards: Except where the Contract Documents include more stringent requirements, applicable construction industry standards have the same force and effect as if bound or copied directly into the Contract Documents. Such standards are made a part of the Contract Documents by reference. Individual Sections indicate which codes and standards the Contractor must keep available at the Project Site for reference.
2. Publication Dates: Where the date of issue of a referenced standard is not specified, comply with the standard in effect as of date of Contract Documents.

3. **Conflicting Requirements:** Where compliance with two or more standards is specified, and they establish different or conflicting requirements for minimum quantities or quality levels, the most stringent requirement will be enforced, unless the Contract Documents indicate otherwise. Refer requirements that are different, but apparently equal, and uncertainties as to which quality level is more stringent to the Architect for a decision before proceeding.
 4. **Copies of Standards:** Each entity engaged in construction on the Project is required to be familiar with industry standards applicable to that entity's construction activity. Copies of applicable standards are not bound with the Contract Documents.
 - a. Where copies of standards are needed for performance of a required construction activity, the Contractor shall obtain copies directly from the publication source.
 - b. Although copies of standards needed for enforcement of requirements also may, be included as part of required submittals, the Architect reserves the right to require the Contractor to submit additional copies as necessary for enforcement of requirements.
- E. **Abbreviations and Names:** Trade association names and titles of general standards are frequently abbreviated. Where such acronyms or abbreviations are used in the Specifications or other Contract Documents, they mean the recognized name of the trade association, standards generating organization, authority having jurisdiction, or other entity applicable to the context of the text provision.

END OF SECTION

THIS PAGE LEFT BLANK INTENTIONALLY

SECTION 01 2600

CONTRACT MODIFICATION PROCEDURES

PART 1 - GENERAL

1.1 RELATED DOCUMENTS

- A. Drawings and general provisions of the Contract, including General and Supplementary Conditions and other Division 1 Specification Sections, apply to this Section.

1.2 SUMMARY

- A. This Section specifies administrative and procedural requirements for handling and processing Contract modifications.
- B. **Related Sections include the following:**
 - 1. Section 01 6000 "**Product Requirements**" for administrative procedures for handling requests for substitutions made after Contract award.

1.3 MINOR CHANGES IN THE WORK

- A. **Architect will issue supplemental instructions** authorizing Minor Changes in the Work, not involving adjustment to the Contract Sum or the Contract Time, on forms issued by the Architect or the Owner.

1.4 PROPOSAL REQUESTS

- A. **Owner-Initiated Proposal Requests:** Architect will issue a detailed description of proposed changes in the Work that may require adjustment to the Contract Sum or the Contract Time. If necessary, the description will include supplemental or revised Drawings and Specifications.
 - 1. Proposal Requests issued by Architect are for information only. Do not consider them instructions either to stop work in progress or to execute the proposed change.
 - 2. Within time specified in Proposal Request after receipt of Proposal Request, submit a quotation estimating cost adjustments to the Contract Sum and the Contract Time necessary to execute the change.
 - a. Include a list of quantities of products required or eliminated and unit costs, with total amount of purchases and credits to be made. If requested, furnish survey data to substantiate quantities.
 - b. Indicate delivery charges, equipment rental, and amounts of trade discounts.
 - c. Include an updated Contractor's Construction Schedule that indicates the effect of the change, including, but not limited to, changes in activity duration, start and finish times, and activity relationship. Use available total float before requesting an extension of the Contract Time.

- B. **Contractor-Initiated Proposals:** If latent or unforeseen conditions require modifications to the Contract, Contractor may propose changes by submitting a request for a change to the Architect.
1. Include a statement outlining reasons for the change and the effect of the change on the Work. Provide a complete description of the proposed change. Indicate the effect of the proposed change on the Contract Sum and the Contract Time.
 2. Include a list of quantities of products required or eliminated and unit costs, with total amount of purchases and credits to be made. If requested, furnish survey data to substantiate quantities.
 3. Indicate applicable taxes, delivery charges, equipment rental, and amounts of trade discounts.
 4. Include an updated Contractor's Construction Schedule that indicates the effect of the change, including, but not limited to, changes in activity duration, start and finish times, and activity relationship. Use available total float before requesting an extension of the Contract Time.
 5. Comply with requirements in Division 1 Section "Product Requirements" if the proposed change requires substitution of one product or system for product or system specified.
- C. **Proposal Request Form:** Use forms issued by the Architect or the Owner.

1.5 CHANGE ORDER PROCEDURES

- A. **On Owner's approval of a Proposal Request,** Contractor shall generate Change Orders on a monthly basis.

1.6 CONSTRUCTION CHANGE DIRECTIVE

- A. **Construction Change Directive:** Architect may issue a Construction Change Directive on AIA Document G714. Construction Change Directive instructs Contractor to proceed with a change in the Work, for subsequent inclusion in a Change Order.
1. Construction Change Directive contains a complete description of change in the Work. It also designates method to be followed to determine change in the Contract Sum or the Contract Time.
- B. **Documentation:** Maintain detailed records on a time and material basis of work required by the Construction Change Directive.
1. After completion of change, submit an itemized account and supporting data necessary to substantiate cost and time adjustments to the Contract.

PART 2 – PRODUCTS - NOT USED

PART 3 – EXECUTION - NOT USED

END OF SECTION

SECTION 01 2900

PAYMENT PROCEDURES

PART 1 - GENERAL

1.1 RELATED DOCUMENTS

- A. Drawings and general provisions of the Contract, including General and Supplementary Conditions and other Division 1 Specification Sections, apply to this Section.

1.2 SUMMARY

- A. This **Section specifies** administrative and procedural requirements necessary to prepare and process Applications for Payment.
- B. **Related Sections** include the following:
 - 1. Section 01 2600 "**Contract Modification Procedures**" for administrative procedures for handling changes to the Contract.

1.3 DEFINITIONS

- A. **Schedule of Values:** A statement furnished by Contractor allocating portions of the Contract Sum to various portions of the Work and used as the basis for reviewing Contractor's Applications for Payment.

1.4 SCHEDULE OF VALUES

- A. **Coordination:** Coordinate preparation of the Schedule of Values with preparation of Contractor's Construction Schedule.
 - 1. Correlate line items in the Schedule of Values with other required administrative forms and schedules, including the following:
 - 2. Application for Payment forms with Continuation Sheets.
 - 3. Submittals Schedule.
 - 4. Submit the Schedule of Values to Architect at earliest possible date but no later than seven days before the date scheduled for submittal of initial Applications for Payment.
 - 5. Sub-schedules: Where the Work is separated into phases requiring separately phased payments, provide sub-schedules showing values correlated with each phase of payment.
- B. **Format and Content:** Use the Project Manual table of contents as a guide to establish line items for the Schedule of Values. Provide at least one line item for each Specification Section.
 - 1. Identification: Include the following Project identification on the Schedule of Values:
 - a. Project name and location.
 - b. Name of Architect.
 - c. Architect's project number.
 - d. Contractor's name and address.
 - e. Date of submittal.
 - 2. Arrange the Schedule of Values in tabular form with separate columns to indicate the following for each item listed:
 - a. Related Specification Section or Division.
 - b. Description of the Work.
 - c. Name of subcontractor.

- d. Name of manufacturer or fabricator.
 - e. Name of supplier.
 - f. Change Orders (numbers) that affect value.
 - g. Dollar value.
 - 1) Percentage of the Contract Sum to nearest one-hundredth percent, adjusted to total 100 percent.
3. Provide a breakdown of the Contract Sum in enough detail to facilitate continued evaluation of Applications for Payment and progress reports. Coordinate with the Project Manual table of contents. Provide several line items for principal subcontract amounts, where appropriate.
 - a. Include line items for Commissioning under principal subcontract amounts, where appropriate.
 4. Round amounts to nearest whole dollar; total shall equal the Contract Sum.
 5. Provide a separate line item in the Schedule of Values for each part of the Work where Applications for Payment may include materials or equipment purchased or fabricated and stored, but not yet installed.
 - a. Differentiate between items stored on-site and items stored off-site. Include evidence of insurance or bonded warehousing if required.
 6. Provide separate line items in the Schedule of Values for initial cost of materials, for each subsequent stage of completion, and for total installed value of that part of the Work.
 7. Each item in the Schedule of Values and Applications for Payment shall be complete. Include total cost and proportionate share of general overhead and profit for each item.
 - a. Temporary facilities and other major cost items that are not direct cost of actual work-in-place may be shown either as separate line items in the Schedule of Values or distributed as general overhead expense, at Contractor's option.
 8. Schedule Updating: Update and resubmit the Schedule of Values before the next Applications for Payment when Change Orders or Construction Change Directives result in a change in the Contract Sum.

1.5 APPLICATIONS FOR PAYMENT

- A. **General:** Each Application for Payment shall be consistent with previous applications and payments as certified by Architect and paid for by Owner.
 1. Initial Application for Payment, Application for Payment at time of Substantial Completion, and final Application for Payment involve additional requirements.
- B. **Payment Application Times:** The date for each progress payment is indicated in the Agreement between Owner and Contractor. The period of construction Work covered by each Application for Payment is the period indicated in the Agreement.
- C. **Payment Application Forms:** Use AIA Document G702 and AIA Document G703 Continuation Sheets as form for Applications for Payment.
- D. **Application Preparation:** Complete every entry on form. Notarize and execute by a person authorized to sign legal documents on behalf of Contractor. Architect will return incomplete applications without action.
 1. Entries shall match data on the Schedule of Values and Contractor's Construction Schedule. Use updated schedules if revisions were made.
 2. Include amounts of Change Orders and Construction Change Directives issued before last day of construction period covered by application.

- E. **Transmittal:** Submit **one signed and notarized original copy** of each Application for Payment to Architect by a method ensuring receipt within 24 hours. One copy shall include waivers of lien and similar attachments if required.
1. Transmit each copy with a transmittal form listing attachments and recording appropriate information about application.
- F. **Application for Payment at Substantial Completion:** After issuing the Certificate of Substantial Completion, submit an Application for Payment showing 100 percent completion for portion of the Work claimed as substantially complete.
1. Include documentation supporting claim that the Work is substantially complete, including commissioning and a statement showing an accounting of changes to the Contract Sum.
 2. This application shall reflect Certificates of Partial Substantial Completion issued previously for Owner occupancy of designated portions of the Work.

PART 2 – PRODUCTS - NOT USED

PART 3 – EXECUTION - NOT USED

END OF SECTION

THIS PAGE LEFT BLANK INTENTIONALLY

SECTION 01 3100

PROJECT MANAGEMENT AND COORDINATION

PART 1 - GENERAL

1.1 RELATED DOCUMENTS

- A. Drawings and general provisions of the Contract, including General and Supplementary Conditions and other Division 1 Specification Sections, apply to this Section.

1.2 SUMMARY

- A. **This Section includes** administrative provisions for coordinating construction operations on Project including, but not limited to, the following:
 - 1. General project coordination procedures.
 - 2. Conservation.
 - 3. Coordination Drawings.
 - 4. File Transfer.
 - 5. Administrative and supervisory personnel.
 - 6. Project meetings.
- B. **The Contractor shall participate in coordination requirements.**
- C. **Related Sections:** The following Sections contain requirements that relate to this Section:
 - 1. Section 01 7300 "**Execution Requirements**" for procedures for coordinating general installation and field-engineering services, including establishment of benchmarks and control points.
 - 2. Section 01 7700 "**Closeout Procedures**" for coordinating Contract closeout.

1.3 COORDINATION

- A. **Coordination:** Coordinate construction operations included in various Sections of the Specifications to ensure efficient and orderly installation of each part of the Work. Coordinate construction operations, included in different Sections, that depend on each other for proper installation, connection, and operation.
 - 1. Schedule construction operations in sequence required to obtain the best results where installation of one part of the Work depends on installation of other components, before or after its own installation.
 - 2. Coordinate installation of different components with other contractors to ensure maximum accessibility for required maintenance, service, and repair.
 - 3. Make adequate provisions to accommodate items scheduled for later installation.
- B. **Memoranda:** If necessary, prepare memoranda for distribution to each party involved, outlining special procedures required for coordination. Include such items as required notices, reports, and list of attendees at meetings.
 - 1. Prepare similar memoranda for Owner and separate contractors if coordination of their Work is required.

- C. **Administrative Procedures:** Coordinate scheduling and timing of required administrative procedures with other construction activities and activities of other contractors to avoid conflicts and to ensure orderly progress of the Work. Such administrative activities include, but are not limited to, the following:
1. Preparation of Contractor's Construction Schedule.
 2. Preparation of the Schedule of Values.
 3. Installation and removal of temporary facilities and controls.
 4. Delivery and processing of submittals.
 5. Progress meetings.
 6. Preinstallation conferences.
 7. Project closeout activities.
- D. **Administrative Requirements:** Contractor shall submit all project related information (i.e. submittals, RFI's, ASI's, addenda, construction documents, project logs, field reports, and meeting minutes) using the Owner's Submittal Exchange. Architect will provide access information to the Contractor at the pre-construction meeting or as appropriate to the schedule of the project.
1. Contractor shall employ a PDF review software system such as Blue Beam (www.bluebeam.com) or another similar system for producing, formatting, and marking-up project related documents. Contractor shall review all the documents and add their stamp and comments directly to the PDF prior to posting for the Architect to review.
 2. Contractor shall provide to the Architect and Owner an electronic archive of all data at the end of the project via DVD(s) for final project records.
- E. **Contractor is to keep a printed record** of all Construction Documents including all clarifications, RFI's and approved changes to the Contract **on site**.
- F. **Conservation:** Coordinate construction activities to ensure that operations are carried out with consideration given to conservation of energy, water, and materials.
1. Salvage materials and equipment involved in performance of, but not actually incorporated into, the Work.

1.4 SUBMITTALS

- A. **Staff Names:** Within 5 business days of starting construction operations, submit a list of principal staff assignments, including superintendent and other personnel in attendance at Project site. Identify individuals and their duties and responsibilities; list addresses and telephone numbers, including home and office telephone numbers. Provide names, addresses, and telephone numbers of individuals assigned as standbys in the absence of individuals assigned to Project.
1. Post copies of list in Project meeting room, in temporary field office, and by each temporary telephone.
- B. **Submittal Log:** See section 'Submittals' for electronic delivery and record keeping.
- C. **Coordination Drawings:** Provide complete coordination drawings as specified in "Coordination Meetings and Submittals".

1.5 ADMINISTRATIVE AND SUPERVISORY PERSONNEL

- A. **General:** In addition to Project superintendent, provide other administrative and supervisory personnel as required for proper performance of the Work.

- B. **Perform project quality control** in accordance with requirements specified in Related Sections, including:
1. Division 1 Section "Quality Control Services".
 2. Division 1 Section "Construction Waste Management and Disposal".
- C. **Contractor's Environmental Training Program:** Provide environmental training for workers performing work on the project site. Training shall include the following:
1. Overview of environmental issues related to the building industry.
 2. Overview of environmental issues related to the Project.
 3. Review of site specific procedures and management plans:
 - a. Section 01 7419 - Construction Waste Management
 - b. Pollution Prevention (P2) practices: Submit evidence of P2 training, participation in P2 programs and familiarity with P2 practices.
 - c. Green Building Rating Programs: Submit evidence of familiarity with USGBC-LEED.
 - d. Compliance with environmental regulations: Submit Contractor 40 CFR employee training records upon request of Owner.

1.6 CONSTRUCTION PROGRESS DOCUMENTATION

- A. **Progress Photographs:**
1. Photographically document site conditions prior to start of construction operations.
 2. Take weekly photographs throughout the entire project. Photographs shall be provided for unrestricted use by Owner.
 - a. Indicate photographs demonstrating environmental procedures.
- B. **Green Building Rating Program Documentation:**
1. Prepare and submit package of documentation required in accordance with USGBC-LEED. Respond to requests for answers to questions and other information from USGBC and the Architect to complete the LEED application process.
 2. Evaluate progress toward goals set in Section 01 1000 - Summary of Work, including green building rating Section 01 8113.14 Sustainable Design Requirements – LEED v4 BD+C and other goals. Coordinate work as necessary to meet the goals.
- C. **Provide documentation for environmental procedures** as specified herein and in accordance with approved Solid Waste Management Plan, IAQ Management Plan, and Environmental Protection Plan.

1.7 PROJECT MEETINGS

- A. **General:** Schedule and conduct meetings and conferences at Project site, unless otherwise indicated.
1. Attendees: Inform participants and others involved, and individuals whose presence is required, of date and time of each meeting. Notify Owner and Architect of scheduled meeting dates and times.
 2. Agenda: Prepare the meeting agenda. Distribute the agenda to all invited attendees.
 3. Minutes: Record significant discussions and agreements achieved. Distribute the meeting minutes to everyone concerned, including Owner and Architect, within 3 days of the meeting.

- B. **Preconstruction Conference:** Schedule a preconstruction conference before starting construction, at a time convenient to Owner and Architect, but no later than 15 days after execution of the Agreement. Hold the conference at Project site or another convenient location. Conduct the meeting to review responsibilities and personnel assignments.
1. Attendees: Authorized representatives of Owner, Architect, and their consultants; Contractor and its superintendent; major subcontractors; manufacturers; suppliers; and other concerned parties shall attend the conference. All participants at the conference shall be familiar with Project and authorized to conclude matters relating to the Work.
 2. Agenda: Discuss items of significance that could affect progress, including the following:
 - a. Tentative construction schedule.
 - b. Phasing.
 - c. Critical work sequencing.
 - d. Designation of responsible personnel.
 - e. Procedures for processing field decisions and Change Orders.
 - f. Procedures for processing Applications for Payment.
 - g. Distribution of the Contract Documents.
 - h. Submittal procedures.
 - i. Preparation of Record Documents.
 - j. Use of the premises.
 - k. Responsibility for temporary facilities and controls.
 - l. Parking availability.
 - m. Office, work, and storage areas.
 - n. Equipment deliveries and priorities.
 - o. First aid.
 - p. Security.
 - q. Progress cleaning.
 - r. Working hours.
 - s. LEED certification requirements and related site and documentation procedures.
 3. Documentation: Furnish Architect certificate of insurance naming VCBO as an additional insured.
- C. **Progress Meetings:** Conduct progress meetings at intervals as agreed by Owner, Contractor and Design Professionals. Coordinate dates of meetings with preparation of payment requests.
1. Reporting: Distribute minutes of the meeting to each party present and to parties who should have been present. Include a brief summary, in narrative form, of progress since the previous meeting and report.
 - a. Schedule Updating: Revise Contractor's Construction Schedule after each progress meeting where revisions to the schedule have been made or recognized. Issue revised schedule concurrently with the report of each meeting.

1.8 REQUESTS FOR INFORMATION (RFI)

- A. **Procedure:** Immediately on discovery of the need for interpretation of Contract Document, and if not possible to request interpretation at Project meeting, prepare and submit an RFI in the form specified.
1. RFIs shall be submitted by the Contractor. RFIs submitted by entities other than Contractor will be returned with no response.
 2. Coordinate and submit RFIs in a prompt manner so as to avoid delays in Contractor's work or work of subcontractors.
 3. Contractor is to keep a printed record of all RFI's and post them on the 'Record Drawings' kept on site.

- B. **Content of the RFI:** Include a detailed, legible description of item needing interpretation and the following:
1. Project name.
 2. Date.
 3. Name of Contractor.
 4. Name of Architect and Owner.
 5. RFI number, numbered sequentially.
 6. Specification Section number and title and related paragraphs, as appropriate.
 7. Drawing number and detail references, as appropriate.
 8. Field dimensions and conditions, as appropriate.
 9. Contractor's suggested solution(s). If Contractor's solution(s) impact the Contractor Time or the Contract Sum, Contractor shall state impact in the RFI.
 10. Contractor's signature.
 11. Attachments: Include drawings, descriptions, measurements, photos, Product Data, Shop Drawings, and other information necessary to fully describe items needing interpretation.
 - a. Supplementary drawings prepared by Contractor shall include dimensions, thickness, structural grid references, and details of affected materials, assemblies, and attachments.
- C. **Electronic RFI's:**
1. RFI's shall be processed and delivered electronically through web-based RFI processing software (via Owner's Submittal Exchange).
 2. Identify each page of attachments with the General Contractors RFI number and sequential page number.
 3. Attachments shall be electronic files in PDF format.
- D. **Architect's Action:** Architect will review each RFI, determine action required, and return it. Allow seven working days for Architect's response for each RFI. RFI's received after 1:00 p.m. will be considered as received the following working day.
1. The following RFIs will be returned without action:
 - a. Requests for approval of submittals.
 - b. Request for approval of substitutions.
 - c. Requests for coordination information already indicated in the Contract Documents.
 - d. Request for adjustments in the Contract Time or Contract Sum.
 - e. Requests for interpretation of Architect's actions on submittals.
 - f. Incomplete RFIs or RFI with numerous errors.
 2. Architect's action may include a request for additional information, in which case Architect's Time for response will start again.
 3. Architect's action on RFI that may result a change to the Contract Time or the Contract Sum may be eligible for Contractor to submit Change Proposal according to Division 01 Section "Contract Modification Procedures."
 - a. If Contractor believes the RFI response warrants change in the Contract Time or the Contract Sum, notify Architect and Owner in writing within 10 calendar days of receipt of the RFI response.
- E. **On receipt of Architect's Owner's action,** update the RFI log and immediately distribute the RFI response to the affected parties. Review response and notify Architect and Owner within seven calendar days if Contractor disagrees with response.
- F. **RFI Log:** Prepare, maintain, and submit a tabular log of RFIs organized by RFI number. Submit log monthly.
1. Project name.
 2. Name and address of Contractor.
 3. Name and address of Architect and Owner.
 4. RFI number including RFIs that were dropped and not submitted.
 5. RFI description.

6. Date the RFI was submitted.
7. Date Architect's and Owner's response was received.
8. Identification of related Minor Change in the Work, Construction Change Directive, and Proposal Request, as appropriate.
9. Identification of related Field Order, Work Change Directive, and Proposal Request, as appropriate.

PART 2 – PRODUCTS - NOT USED

PART 3 - EXECUTION - NOT USED

END OF SECTION

SECTION 01 3300

SUBMITTAL PROCEDURES

PART 1 - GENERAL

1.1 RELATED DOCUMENTS

- A. Drawings and general provisions of the Contract, including General and Supplementary Conditions and Division 1 Specification Sections, apply to this Section

1.2 SUMMARY

- A. This Section specifies **administrative and procedural requirements for submittals** required for performance of the Work, including:
 - 1. Contractor's construction schedule.
 - 2. Daily construction reports.
 - 3. Shop Drawings.
 - 4. Product Data.
 - 5. Samples.
 - 6. Delegated Design/Deferred Submittals for review by the Building Code Official.
- B. **Administrative Submittals:** Refer to other Division-1 Sections and other Contract Documents for requirements for administrative submittals. Such submittals include, but are not limited to:
 - 1. Applications for payment.
 - 2. Performance and payment bonds.
 - 3. Insurance certificates.
 - 4. List of Subcontractors.
- C. **Related Sections:**
 - 1. Section 01 3100 "**Project Management and Coordination**" for electronic web-based construction administration software (using Owner's Submittal Exchange).
 - 2. Section 01 4000 "**Quality Control Services**" for inspection and test reports.

1.3 ELECTRONIC SUBMITTAL DELIVERY

- A. **To minimize printing reimbursables**, shipping reimbursables and the impact on the environment, process and deliver submittals electronically through Submittal Exchange.
 - 1. One complete hard copy of each submittal shall also be furnished for verification of the completeness of electronic submission, if requested by Architect.
- B. **Construction Manager or General Contractor** must first review and approve submittals sent by Subcontractors prior to sending to Architect. Include Contractor's certification that information complies with Contract Document requirements; record deviations from Contract Document requirements, including minor variations and limitations.
 - 1. Contractor shall coordinate numbering system and nomenclature with Architect prior to first submissions.
 - 2. Email notifications of items delivered to Submittal Exchange shall be sent to both the project manager and the appropriate administrative assistant in the Architect's office simultaneously with posting to Submittal Exchange.
- C. **Submittals must follow the requirements outlined** in this specification and as required in individual specification sections.

- D. **Deliver the following** to the Architect electronically in pdf format:
1. Product Data
 2. Shop Drawings
 3. Certifications
 4. Test Data
 5. Schedules
 6. Calculations
 7. Mix Designs
 8. Warranty Information
 9. LEED Information
- E. **Samples and Color Selection**
1. Log physical samples via Submittal Exchange, but deliver by mail or courier to the Architect for review.
 2. Samples and color selection will not be reviewed electronically.
 3. See separate specification sections for quantities and sample selection process. The Architect shall return review comments via the Architect's File Transfer Site.
- F. **Submittal Stamps**
1. Contractor or Construction Manager shall affix an electronic stamp to PDF submittals.
- G. **Submittal Logs**
1. Architect shall maintain a submittal log through Submittal Exchange, however, General Contractor or Construction Manager shall be responsible for maintaining the official submittal log.

1.4 SUBMITTAL PROCEDURES

- A. **No submittal will be accepted** by the Architect **without the General Contractor's action stamp**, clearly visible, indicating that the submittal has been fully reviewed by the General Contractor for compliance to the Construction Documents.
- B. **Submittals with the General Contractor's stamp but not in compliance** with the Construction Documents will be deemed incomplete and returned without review. These will not be shown as received.
- C. **Coordination:** Coordinate preparation and processing of submittals with performance of construction activities. Transmit each submittal sufficiently in advance of performance of related construction activities to avoid delay.
1. Coordinate transmittal of different types of submittals for related elements of the Work so processing will not be delayed by the need to review submittals concurrently for coordination.
 - a. The Architect reserves the right to withhold action on a submittal requiring coordination with other submittals until related submittals are received.
- D. **Processing Time:** Allow enough time for submittal review, including time for resubmittals, as follows. Time for review shall commence on Architect's receipt of submittal.
1. **Initial Review:** Allow 14 calendar days for initial review of each submittal. Allow additional time if processing must be delayed to permit coordination with subsequent submittals. Architect will advise Contractor when a submittal being processed must be delayed for coordination.
 2. **Concurrent Review:** Where concurrent review of submittals by Architect's consultants, Owner, or other parties is required, allow 21 calendar days for initial review of each submittal.

3. Deferred Submittal Review: Where deferred submittals are required by the Building Code Official allow review time as dictated by the Official.
 4. If intermediate submittal is necessary, process it in same manner as initial submittal.
 5. Allow 14 calendar days for processing each resubmittal.
 6. No extension of the Contract Time will be authorized because of failure to transmit submittals enough in advance of the Work to permit processing.
- E. **Submittal Preparation:** Place a permanent label or title block on each submittal for identification. Indicate the name of the entity that prepared each submittal on the label or title block.
1. Include the following information on the label for processing and recording action taken.
 - a. Project name.
 - b. Date.
 - c. Name and address of Architect.
 - d. Name and address of Contractor.
 - e. Name and address of Subcontractor.
 - f. Name and address of Supplier.
 - g. Name of Manufacturer.
- F. **Submittal Transmittal:** Package each submittal appropriately for transmittal and handling. Transmit each submittal from Contractor to Architect using a transmittal form. Submittals received from sources other than the Contractor will be returned without action.
1. On the form, or separate sheet, record deviations from Contract Document requirements, including minor variations and limitations. Include Contractor's certification that information complies with Contract Document requirements.
- G. **Submittal requirements** for electronic PDF submittals:
1. Create submittals with native PDF files whenever possible. Do not print a PDF file, and scan in as an image file, as this will delete all file search functions typically embedded within a native PDF file.
 2. Break down PDF submittals by individual specification section. Do not collate multiple specification sections together into one non-separated submittal package (i.e. carpet, VCT, rubber base, and entry mats; though frequently provided by one installer, shall not be submitted as one non-separated package unless formatted as described below.)
 3. All PDF submittals that cover multiple items within one specification section, or PDF submittals that include multiple related specification sections shall have an index and be formatted with electronic book marks to distinguish various components from one another, and make each item easily retrievable without navigating through each page of an entire submittal.

1.5 CONTRACTOR'S CONSTRUCTION SCHEDULE

- A. **Bar-Chart Schedule:** Prepare a fully developed, horizontal bar-chart type Contractor's construction schedule.
1. Provide a separate time bar for each significant construction activity. Provide a continuous vertical line to identify the first working day of each week. Use the same breakdown of units of the Work as indicated in the "Schedule of Values".
 2. Within each time bar indicate estimated completion percentage in 10 percent increments. As Work progresses, place a contrasting mark in each bar to indicate Actual Completion.
 3. Prepare the schedule on a sheet of sufficient width to show data for the entire construction period.

4. Secure time commitments for performing critical elements of the Work from parties involved. Coordinate each element on the schedule with other construction activities; include minor elements involved in the sequence of the Work. Show each activity in proper sequence. Indicate graphically sequences necessary for completion of related portions of the Work.
 5. Coordinate the Contractor's construction schedule with the schedule of values, list of subcontracts, submittal schedule, progress reports, payment requests and other schedules.
 6. Indicate completion in advance of the date established for Substantial Completion. Indicate Substantial Completion on the schedule to allow time for the Architect's procedures necessary for certification of Substantial Completion.
- B. **Distribution:** Following response to the initial submittal, print and distribute copies to the Architect, Owner, subcontractors, and other parties required to comply with scheduled dates. Post copies in the Project meeting room and temporary field office.
1. When revisions are made, distribute to the same parties and post in the same locations. Delete parties from distribution when they have completed their assigned portion of the Work and are no longer involved in construction activities.
- C. **Schedule Updating:** Revise the schedule after each meeting or activity, where revisions have been recognized or made. Issue the updated schedule concurrently with report of each meeting.

1.6 DAILY CONSTRUCTION REPORTS

- A. **Daily Construction Report:** Prepare a daily construction report, recording the following information concerning events at the site; and submit duplicate copies to the Architect at weekly intervals:
1. List of subcontractors at the site.
 2. Approximate count of personnel at the site.
 3. High and low temperatures, general weather conditions.
 4. Accidents and unusual events.
 5. Meetings and significant decisions.
 6. Stoppages, delays, shortages, losses.
 7. Meter readings and similar recordings.
 8. Orders and requests of governing authorities.
 9. Change Orders received, implemented.
 10. Services connected, disconnected.
- B. **Material Location Reports:** At monthly intervals, prepare a comprehensive list of materials delivered to and stored at Project site. List shall be cumulative, showing materials previously reported plus items recently delivered. Include with list a statement of progress on and delivery dates for materials or items of equipment fabricated or stored away from Project site.
- C. **Field Condition Reports:** Immediately on discovery of a difference between field conditions and the Contract Documents, prepare a detailed report. Submit with a request for information on CSI Form 13.2A. Include a detailed description of the differing conditions, together with recommendations for changing the Contract Documents.

1.7 SPECIAL REPORTS

- A. **General:** Submit special reports directly to Owner within one day of an occurrence. Distribute copies of report to parties affected by the occurrence.

- B. **Reporting Unusual Events:** When an event of an unusual and significant nature occurs at Project site, whether or not related directly to the Work, prepare and submit a special report. List chain of events, persons participating, response by Contractor's personnel, evaluation of results or effects, and similar pertinent information. Advise Owner in advance when these events are known or predictable.

1.8 SHOP DRAWINGS

- A. **Submit newly prepared information,** drawn to accurate scale. Highlight, encircle, or otherwise indicate deviations from the Contract Documents. Do not reproduce Contract Documents or copy standard information as the basis of Shop Drawings.
- B. **Shop Drawings include** fabrication and installation drawings, setting diagrams, schedules, patterns, templates and similar drawings. Include the following information:
1. Dimensions.
 2. Identification of products and materials included.
 3. Compliance with specified standards.
 4. Notation of coordination requirements.
 5. Notation of dimensions established by field measurement.
- C. **Sheet Size:** Submit Shop Drawings, layout drawings and other Revit or CADD style sheets formatted for 24 x 36 inch or 30 x 42 inch sheets. Details and drawings are to match or exceed construction bid document scales. All drawings are to be submitted to scale. All other product brochures and cut sheets can be provided in an 8-1/2 x 11 format.
- D. **Final Electronic Submittal:** Submit 2 prints, one for the Architect and one for the Owner at the end of the project or as requested by the parties during construction.
1. If submittal was reviewed by members of the design team other than the Architect, provide an additional copy of the submittal for each design firm.
 2. The prints shall be marked-up and maintained as a "Record Document".

1.9 DELEGATED DESIGN/DEFERRED SUBMITTALS

- A. **Performance and Design Criteria:** Where professional design services or certifications by a design professional are specifically required of Contractor by the Contract Documents, provide products and systems complying with specific performance and design criteria indicated.
1. If criteria indicated are not sufficient to perform services or certification required, submit a written request for additional information to Architect.
- B. **Delegated-Design Services Certification:** In addition to Shop Drawings, Product Data, and other required submittals, submit digitally signed PDF electronic file and three paper copies of certificate, signed and sealed by the responsible design professional, for each product and system specifically assigned to Contractor to be designed or certified by a design professional.
1. Indicate that products and systems comply with performance and design criteria in the Contract Documents. Include list of codes, loads, and other factors used in performing these services.
- C. **Refer to the General Information sheet** on the Drawings for a list of required delegated design/deferred submittals.
- D. **Submit deferred submittals** on same size sheet as original drawings (30 x 42 or 8 1/2 x

11). Drawings and calculations shall be on the Design Professional's title block stating the project name and all other items specified under 'Submittal Preparation' above.

- E. **Furnish deferred submittals to the Architect** who will electronically submit to the Building Code Official for review as required by the IBC.
- F. Contractor shall include these submittal sheets in the Record Documents.

1.10 PRODUCT DATA

- A. **Submit in timely manner** to complete project, but **no later than 90 days** after Notice of Award.
- B. **Collect Product Data into a single submittal** for each element of construction or system. Product Data includes printed information such as manufacturer's installation instructions, catalog cuts, standard color charts, roughing-in diagrams and templates, standard wiring diagrams and performance curves. Where Product Data must be specially prepared because standard printed data is not suitable for use, submit as "Shop Drawings."
 - 1. Mark each copy to show applicable choices and options. Where printed Product Data includes information on several products, some of which are not required, mark copies to indicate the applicable information. Include the following information:
 - a. Manufacturer's printed recommendations.
 - b. Compliance with recognized trade association standards.
 - c. Compliance with recognized testing agency standards.
 - d. Application of testing agency labels and seals.
 - e. Notation of dimensions verified by field measurement.
- C. **Do not submit Product Data until** compliance with requirements of the Contract Documents has been confirmed.
- D. **Submittals:** Submit 4 copies of each required submittal; submit 6 copies where required for maintenance manuals. The Architect will retain one, and will return the other marked with action taken and corrections or modifications required.
- E. **Electronic Submittals:** Submit a pdf copy of each required submittal; include copies where required for maintenance manuals. See electronic submittal delivery and submittal procedures for further requirements

1.11 SAMPLES

- A. **Submit in timely manner** to complete project, but **no later than 90 days** after Notice of Award.
- B. **Samples:** Submit full-size, fully fabricated samples cured and finished as specified and physically identical with the material or product proposed. Samples include partial sections of manufactured or fabricated components, cuts or containers of materials, color range sets, and swatches showing color, texture and pattern.
- C. **Submittals:** Except for Samples illustrating assembly details, workmanship, fabrication techniques, connections, operation and similar characteristics, submit 3 sets; one will be returned marked with the action taken.
 - 1. Maintain sets of samples and a file of product submittals, as returned, at the Project site, for quality comparisons and product verification throughout the course of construction.

1.12 CONTRACTOR'S REVIEW

- A. **Contractor's Review:** Review each submittal and check for compliance with the Contract Documents. Note corrections and field dimensions. Mark with approval stamp before submitting to Architect.
- B. **Approval Stamp:** Stamp each submittal with a uniform, approval stamp. Include Project name and location, submittal number, Specification Section title and number, name of reviewer, date of Contractor's approval, and statement certifying that submittal has been reviewed, checked, and approved for compliance with the Contract Documents.
- C. **Submittals not marked** with an approval stamp and those not in compliance with the Construction Documents shall be returned without further review. It is the Contractor's responsibility to review submittals for compliance prior to forwarding the submittal to the Design Team for review.

1.13 ARCHITECT'S ACTION

- A. **Architect's Action:** Except for submittals for record, information or similar purposes, where action and return is required or requested, the Architect will review each submittal, mark to indicate action taken, and return promptly.
 - 1. Compliance with specified characteristics is the Contractor's responsibility.
- B. **Action Stamp:** The Architect will stamp each submittal with a uniform, self-explanatory action stamp. The stamp will be appropriately marked to indicate the action taken.
 - 1. Corrections or comments made on the shop drawings during this review do not relieve the Contractor from compliance with requirements of the drawings and specifications. This check is only for review of general conformance with the design concept of the project and general compliance with the information given in the contract documents. The Contractor is responsible for; confirming and correlating all quantities and dimensions; selecting fabrication processes and techniques of construction; coordinating his work with that of all other trades; and performing his work in a safe and satisfactory manner.

PART 2 - PRODUCTS - NOT USED

PART 3 - EXECUTION - NOT USED

END OF SECTION

THIS PAGE LEFT BLANK INTENTIONALLY

SECTION 01 5000

TEMPORARY FACILITIES AND CONTROLS

PART 1 - GENERAL

1.1 RELATED DOCUMENTS

- A. Drawings and general provisions of the Contract, including General and Supplementary Conditions and other Division 1 Specification Sections, apply to this Section.

1.2 SUMMARY

- A. This section specifies administrative and procedural requirements for temporary services and facilities, including such items as temporary utility services, temporary construction and support facilities, and project security and protection.
- B. **Temporary construction and support facilities** required for the project include but are not limited to the following:
 - 1. Sanitary facilities, including drinking water.
 - 2. Hoists.
 - 3. First aid station.
 - 4. Waste disposal services.
 - 5. Construction aids and miscellaneous general services and facilities.
- C. **Security and protection facilities and services** required for the project include but are not limited to the following:
 - 1. Temporary fire protection.
 - 2. Barricades, warning signs, lights.
 - 3. Enclosure fence for stored material.
 - 4. Environmental protection.
- D. **Temporary utilities include, but are not limited to**, the following:
 - 1. Sewers and drainage.
 - 2. Water service and distribution.
 - 3. Electric power service and lighting.
 - 4. Heating and ventilation facilities.

1.3 QUALITY ASSURANCE

- A. **Regulations:** Comply with requirements of local laws and regulations governing construction and local industry standards, in the installation and maintenance of temporary services and facilities, including but not limited to the following:
 - 1. Building codes, including requirements for permits, testing and inspection.
 - 2. Health and safety regulations.
 - 3. Utility company regulations and recommendations governing temporary utility services.
 - 4. Environmental protection regulations governing use of water and energy, and the control of dust, noise and other nuisances.
- B. **Standards:** Comply with the requirements of NFPA Code 241, "Building Construction and Demolition Operations", and ANSI A-10 Series standards for "Safety Requirements for Construction and Demolition", and the NECA National Joint Guideline NJG-6 "Temporary Job Utilities and Services."

- C. Refer to the most current "**Guidelines for Bid Conditions for Temporary Job Utilities and Services**", as prepared jointly by AGC and ASC industry recommendations.

1.4 JOB CONDITIONS

- A. **General:** Provide each temporary service and facility ready for use at each location when the service or facility is first needed to avoid delay in the performance of the work. Maintain, expand as required and modify temporary services and facilities as needed throughout the progress of the Work. Do not remove until services or facilities are no longer needed, or are replaced by the authorized use of completed permanent facilities.
- B. **Conditions of Use:** Operate temporary services and facilities in a safe and efficient manner. Do not overload temporary services or facilities, and do not permit them to interfere with the progress of the work. Do not allow unsanitary conditions, public nuisances or hazardous conditions to develop or persist on the site.
 - 1. **Temporary Construction and Support Facilities:** Maintain temporary facilities in such a manner as to prevent discomfort to users. Take necessary fire prevention measures. Maintain temporary support facilities in a sanitary manner so as to avoid health problems and other deleterious effects.
 - 2. **Security and Protection:** Maintain site security and protection facilities in a safe, lawful and publicly acceptable manner. Take necessary measures to prevent erosion of the site.

PART 2 - PRODUCTS

2.1 MATERIALS AND EQUIPMENT

- A. **General:** Provide new materials and equipment for temporary services and facilities, used materials and equipment that are undamaged and in serviceable condition may be used, if acceptable to the Architect.
- B. **Temporary Support Facilities:** Provide facilities that can be maintained properly throughout their use at the project site. Provide either standard prefabricated or mobile units.
 - 1. **Self-contained Toilet Units:** Provide single-occupant self-contained toilet units of the chemical, aerated recirculation, or combustion type, properly vented and fully enclosed with a glass fiber reinforced polyester shell or similar non-absorbent material.
 - 2. **Tarpaulins:** Provide waterproof, fire-resistant, UL labeled tarpaulins with a flame-spread rating of 15 or less.
 - 3. **First Aid Supplies:** Comply with governing regulations and recognized recommendations within the construction industry.
 - 4. **Drinking Water:** Provide potable water approved by local health authorities.
 - 5. **Sign Materials:** For signs and directory boards, provide exterior type, Grade B-B High Density Concrete Form Overlay Plywood conforming to PS-1, of sizes and thicknesses indicated. Provide exterior grade acrylic-latex-base enamel for painting panels and applying graphics.
- C. **Fire Extinguishers:** Provide type "A" fire extinguishers **for temporary offices and similar spaces** where there is a minimal danger of electrical or grease-oil-flammable liquid fires. In other locations provide type "ABC" dry chemical extinguishers, or a combination of several extinguishers of NFPA recommended types for the exposures in each case.

PART 3 - EXECUTION

3.1 INSTALLATION, GENERAL

- A. **General:** Use qualified tradesmen for installation of temporary services and facilities. Locate temporary services and facilities where they will serve the entire project adequately and result in minimum interference with the performance of the Work.
1. Relocate, modify and extend services and facilities as required during the course of work so as to accommodate the entire work of the project.

3.2 TEMPORARY UTILITY INSTALLATION

- A. **General:** Engage appropriate local utility company to install temporary service or connect to existing service. Where utility company provides only part of the service, provide the remainder with matching, compatible materials and equipment. Comply with utility company recommendations.
1. Arrange with utility company, Owner, and existing users for time when service can be interrupted, if necessary, to make connections for temporary services.
 2. Provide adequate capacity at each stage of construction. Before temporary utility is available, provide trucked-in services.
- B. **Heating and Cooling:** Provide temporary heating and cooling required by construction activities for curing or drying of completed installations or for protecting installed construction from adverse effects of low temperatures or high humidity. Select equipment from that specified that will not have a harmful effect on completed installations or elements being installed.
1. Maintain a minimum temperature of 50 degrees F in permanently enclosed portions of building for normal construction activities, and 65 degrees F for finishing activities and areas where finished Work has been installed.
- C. **Ventilation and Humidity Control:** Provide temporary ventilation required by construction activities for curing or drying of completed installations or for protecting installed construction from adverse effects of high humidity. Select equipment from that specified that will not have a harmful effect on completed installations or elements being installed. Coordinate ventilation requirements to produce ambient condition required and minimize energy consumption.
- D. **Electric Power Service:** Provide weatherproof, grounded electric power service and distribution system of sufficient size, capacity, and power characteristics during construction period. Include meters, transformers, overload-protected disconnecting means, automatic ground-fault interrupters, and main distribution switchgear.
- E. **Electric Distribution:** Provide receptacle outlets adequate for connection of power tools and equipment.
- F. **Lighting:** Provide temporary lighting with local switching that provides adequate illumination for construction operations and traffic conditions.

3.3 TEMPORARY CONSTRUCTION AND SUPPORT FACILITIES INSTALLATION

- A. **General:** Provide a reasonably neat and uniform appearance in temporary construction and support facilities acceptable to the Architect/Engineer and the Owner.
1. Locate support facilities for easy access to the Work. Position offices so that windows give the best possible view of construction activities.
 2. Maintain temporary sanitary facilities, waste collection and disposal systems, and project identification and temporary signs until near substantial completion. Immediately prior to substantial completion remove these facilities.
- B. **Sanitary Facilities:** Sanitary facilities include temporary toilets, wash facilities and drinking water fixtures. Comply with governing regulations including safety and health codes for the type, number, location, operation and maintenance of fixtures and facilities; provide not less than specified requirements. Install in locations that will best serve the project's needs.
1. Sanitary facilities located within the existing facility shall **not** be used by the Contractor.
- C. **Hoists:** Provide adequate facilities for hoisting materials and employees. Do not permit employees to ride hoists which comply only with requirements for hoisting materials. The Contractor is responsible for selection of type, size, and number of facilities. Truck cranes and similar devices used for hoisting are considered as being "tools and equipment" and not temporary facilities.
- D. **Collection and Disposal of Wastes:**
1. Establish a system for daily collection and disposal of waste or extraneous materials from all construction areas on site that may present a hazard to the project, its craftsmen and the expeditious construction of the work. The Contractor shall provide to the Owner a satisfactory method to assure clean-up is performed in a timely and expeditious fashion. Enforce requirements strictly. Do not hold collected materials at the site longer than 1 day. Handle waste materials that are hazardous, dangerous, or unsanitary separately from other inert waste by containerizing appropriately. Dispose of waste material in a lawful manner.
 - a. Burying or burning of waste materials on the site will not be permitted.
 - b. Washing waste materials down sewers or into waterways will not be permitted.
 - c. Provide rodent proof containers located on each floor level of construction work, to encourage depositing of lunch garbage and similar wastes by construction personnel.
 2. The Owner reserves the right to withhold payments and perform the clean-up, if necessary, at the expense of the Contractor, if unsatisfactory clean-up efforts are not performed in a timely fashion.
- E. **Construction Aids and Miscellaneous Services and Facilities:**
1. Design, construct, and maintain construction aids and miscellaneous general services and facilities as needed to accommodate performance of the work. Construction aids and miscellaneous general services and facilities include, but or not limited to the following:
 - a. Temporary stairs and ladders.
 - b. Guardrails and barriers.
 2. Stairs: Provide temporary stairs where ladders are not adequate for performance of work.
 3. Guardrails and Barriers: Provide guardrails at all unprotected edges of floor and roof openings, and at perimeter of roof and unenclosed floors.

3.4 SECURITY AND PROTECTION FACILITIES INSTALLATION

- A. **General:** Provide a reasonably neat and uniform appearance to security and protection facilities acceptable to the Architect/Engineer and the Owner.
- B. **Temporary Fire Protection:**
1. Install and maintain temporary fire protection facilities of the types needed to adequately protect against reasonably predictable and controllable fire losses. Comply with applicable recommendations of the NFPA Standard 10 "Standard for Portable Fire Extinguishers". Locate fire extinguishers where they are most convenient and effective for their intended purpose. Store combustible materials in containers in recognized fire-safe locations.
 2. Develop and supervise an overall fire prevention and first-aid fire protection program for personnel at the project site. Review needs with the local fire department officials and establish procedures to be followed. Instruct personnel in methods and procedures to be followed. Post warnings and information and enforce strict discipline. Maintain unobstructed access to fire extinguishers, fire hydrants, temporary fire protection facilities, stairways and other access routes for fighting fires. Prohibit smoking of any kind on Owner's property. Provide supervision of welding operations, and similar sources of ignition for possible fires.
- C. **Security Enclosure and Lockups:**
1. Install general temporary enclosure of partially completed areas of construction. Provide locking entrances adequate to deter unauthorized entrance, vandalism, theft and similar deleterious effects of violations of project security.
 2. Storage: Where materials and equipment must be temporarily stored, prior to and during construction, and are of substantial value or are attractive for possible theft, provide a secure lockup and enforce strict discipline in connection with the timing of installation and release of materials, so that the opportunity for theft and vandalism is minimized.
- D. **General Environmental Protection:** Provide general protection facilities, operate temporary facilities, conduct construction activities, and enforce strict discipline for personnel on the site in ways and by methods that comply with environmental regulations, and that minimize the possibility that air, waterways and subsoil might be contaminated or polluted, or that other undesirable effects might result from the performance of work at the site. Avoid the use of tools and equipment which produce harmful noise. Restrict the use of noise making tools and equipment to hours of use that will minimize noise complaints from persons and firms within the building or near the project site.

3.5 OPERATION, TERMINATION AND REMOVAL

- A. **Supervision:** Enforce strict discipline in use of temporary services and facilities at the site. Limit availability of temporary services and facilities to essential and intended uses to minimize waste and abuse. Do not permit temporary installations to be abused or endangered. Do not allow hazardous, dangerous or unsanitary conditions to develop or persist on the project site.
- B. **Maintenance:** Operate and maintain temporary services and facilities in good operating condition throughout the time of use and until removal is authorized. Protect from damage by freezing temperatures and similar elements.

- C. **Termination and Removal:** Unless the Architect requests that it be maintained for a longer period of time, remove each temporary service and facility promptly when the need for it or a substantial portion of it has ended, or when it has been replaced by the authorized use of a permanent facility, or no later than substantial completion. Complete, or, if necessary, restore permanent work which may have been delayed because of interference with the temporary service or facility. Repair damaged work, clean exposed surfaces and replace work which cannot be satisfactorily repaired.
1. Materials and facilities that constitute temporary services and facilities and remain the property of the Contractor.

END OF SECTION

SECTION 01 6000

PRODUCT REQUIREMENTS

PART 1 - GENERAL

1.1 RELATED DOCUMENTS

- A. Drawings and general provisions of the Contract, including General and Supplementary Conditions and other Division 1 Specification Sections, apply to this Section.

1.2 SUMMARY

- A. **This Section includes** the following administrative and procedural requirements: selection of products for use in Project; product delivery, storage, and handling; manufacturers' standard warranties on products; special warranties; product substitutions; and comparable products.
- B. **Related Sections** include the following:
 - 1. Section 01 1900 "**Definitions and Standards**" for applicable industry standards for products specified.
 - 2. Section 01 7700 "**Closeout Procedures**" for submitting warranties for contract closeout.
 - 4. **Divisions 2 through 48 Sections** for specific requirements for warranties on products and installations specified to be warranted.

1.3 DEFINITIONS

- A. **Products:** Items purchased for incorporating into the Work, whether purchased for Project or taken from previously purchased stock. The term "product" includes the terms "material," "equipment," "system," and terms of similar intent.
 - 1. **Named Products:** Items identified by manufacturer's product name, including make or model number or other designation, shown or listed in manufacturer's published product literature that is current as of date of the Contract Documents.
 - 2. **New Products:** Items that have not previously been incorporated into another project or facility. Products salvaged or recycled from other projects are not considered new products. Only new products are allowed to be used unless directed by the Architect in writing.
 - 3. **Comparable Product:** Product that is demonstrated and approved through submittal process, or where indicated as a product substitution, to have the indicated qualities related to type, function, dimension, in-service performance, physical properties, appearance, and other characteristics that equal or exceed those of specified product.
- B. **Substitutions:** Changes in products, materials, equipment, and methods of construction from those required by the Contract Documents and proposed by Contractor.
- C. **Basis-of-Design Product Specification:** Where a specific manufacturer's product is named and accompanied by the words "basis of design," including make or model number or other designation, to establish the significant qualities related to type, function, dimension, in-service performance, physical properties, appearance, and other characteristics for purposes of evaluating comparable products of other named manufacturers.

- D. **Manufacturer's Warranty:** Preprinted written warranty published by individual manufacturer for a particular product and specifically endorsed by manufacturer to Owner.
- E. **Special Warranty:** Written warranty required by or incorporated into the Contract Documents, either to extend time limit provided by manufacturer's warranty or to provide more rights for Owner.

1.4 SUBMITTALS

- A. **Product List:** Submit a list, in tabular form, showing specified products. Include generic names of products required. Include manufacturer's name and proprietary product names for each product.
 - 1. Coordination: Coordinate product list with Contractor's Construction Schedule and the Submittals Schedule.
 - 2. Form: Tabulate information for each product under the following column headings:
 - a. Specification Section number and title.
 - b. Generic name used in the Contract Documents.
 - c. Proprietary name, model number, and similar designations.
 - d. Manufacturer's name and address.
 - e. Supplier's name and address.
 - f. Installer's name and address.
 - g. Projected delivery date or time span of delivery period.
 - h. Identification of items that require early submittal approval for scheduled delivery date.
 - 3. Initial Submittal: Within 30 days after date of commencement of the Work, submit 3 copies of initial product list. Include a written explanation for omissions of data and for variations from Contract requirements.
 - a. At Contractor's option, initial submittal may be limited to product selections and designations that must be established early in Contract period.
 - 4. Completed List: Within 60 days after date of commencement of the Work, submit 3 copies of completed product list. Include a written explanation for omissions of data and for variations from Contract requirements.
 - 5. Architect's Action: Architect will respond in writing to Contractor within 15 days of receipt of completed product list. Architect's response will include a list of unacceptable product selections and a brief explanation of reasons for this action. Architect's response, or lack of response, does not constitute a waiver of requirement that products comply with the Contract Documents.
- B. **Substitution Requests:** Submit three copies of each request for consideration. Identify product or fabrication or installation method to be replaced. Include Specification Section number and title and Drawing numbers and titles.
 - 1. Substitution Request Form: Use CSI Form 13.1A.
 - 2. Documentation: Show compliance with requirements for substitutions and the following, as applicable:
 - a. Statement indicating why specified material or product cannot be provided.
 - b. Coordination information, including a list of changes or modifications needed to other parts of the Work and to construction performed by Owner and separate contractors, that will be necessary to accommodate proposed substitution.
 - c. Detailed comparison of significant qualities of proposed substitution with those of the Work specified. Significant qualities may include attributes such as performance, weight, size, durability, visual effect, and specific features and requirements indicated.

- d. Product Data, including drawings and descriptions of products and fabrication and installation procedures.
 - e. Samples, where applicable or requested.
 - f. List of similar installations for completed projects with project names and addresses and names and addresses of architects and owners.
 - g. Material test reports from a qualified testing agency indicating and interpreting test results for compliance with requirements indicated.
 - h. Research/evaluation reports evidencing compliance with building code in effect for Project, from a model code organization acceptable to authorities having jurisdiction.
 - i. Detailed comparison of Contractor's Construction Schedule using proposed substitution with products specified for the Work, including effect on the overall Contract Time. If specified product or method of construction cannot be provided within the Contract Time, include letter from manufacturer, on manufacturer's letterhead, stating lack of availability or delays in delivery.
 - j. Cost information, including a proposal of change, if any, in the Contract Sum.
 - k. Contractor's certification that proposed substitution complies with requirements in the Contract Documents and is appropriate for applications indicated.
 - l. Contractor's waiver of rights to additional payment or time that may subsequently become necessary because of failure of proposed substitution to produce indicated results.
3. Architect's Action: If necessary, Architect will request additional information or documentation for evaluation within one week of receipt of a request for substitution. Architect will notify Contractor of acceptance or rejection of proposed substitution within 15 business days of receipt of request, or 7 business days of receipt of additional information or documentation, whichever is later.
- a. Form of Acceptance: Change Order.
 - b. Use product specified if Architect cannot make a decision on use of a proposed substitution within time allocated.

- C. **Basis-of-Design Product Specification Submittal:** Comply with requirements in Division 1 Section "Submittals." Show compliance with requirements.

1.5 QUALITY ASSURANCE

- A. **Compatibility of Options:** If Contractor is given option of selecting between two or more products for use on Project, product selected shall be compatible with products previously selected, even if previously selected products were also options.
- 1. Each contractor is responsible for providing products and construction methods compatible with products and construction methods of other contractors.
 - 2. If a dispute arises between contractors over concurrently selectable but incompatible products, Architect will determine which products shall be used.

1.6 PRODUCT DELIVERY, STORAGE, AND HANDLING

- A. **Deliver, store, and handle products** using means and methods that will prevent damage, deterioration, and loss, including theft. Comply with manufacturer's written instructions.
- 1. Schedule delivery to minimize long-term storage at Project site and to prevent overcrowding of construction spaces.
 - 2. Coordinate delivery with installation time to ensure minimum holding time for items that are flammable, hazardous, easily damaged, or sensitive to deterioration, theft, and other losses.

3. Deliver products to Project site in an undamaged condition in manufacturer's original sealed container or other packaging system, complete with labels and instructions for handling, storing, unpacking, protecting, and installing.
4. Inspect products on delivery to ensure compliance with the Contract Documents and to ensure that products are undamaged and properly protected.
5. Store products to allow for inspection and measurement of quantity or counting of units.
6. Store materials in a manner that will not endanger Project structure.
7. Store products that are subject to damage by the elements, under cover in a weathertight enclosure above ground, with ventilation adequate to prevent condensation.
8. Comply with product manufacturer's written instructions for temperature, humidity, ventilation, and weather-protection requirements for storage.
9. Protect stored products from damage.
10. Store products to meet LEED indoor air quality plan requirements.

1.7 PRODUCT WARRANTIES

- A. **General:** Warranties specified in other Sections shall be in addition to, and run concurrent with, other warranties required by the Contract Documents. Manufacturer's disclaimers and limitations on product warranties do not relieve Contractor of obligations under requirements of the Contract Documents.
- B. **Special Warranties:** Prepare a written document that contains appropriate terms and identification, ready for execution. Submit a draft for approval before final execution.
 1. Manufacturer's Standard Form: Modified to include Project-specific information and properly executed.
 2. Refer to Divisions 2 through 48 Sections for specific content requirements and particular requirements for submitting special warranties.
- C. **Submittal Time:** Comply with requirements in Division 1 Section "Closeout Procedures."

PART 2 - PRODUCTS

2.1 PRODUCT OPTIONS

- A. **General Product Requirements:** Provide products that comply with the Contract Documents, that are undamaged, and unless otherwise indicated, that are new at time of installation.
 1. Provide products complete with accessories, trim, finish, fasteners, and other items needed for a complete installation and indicated use and effect.
 2. Standard Products: If available, and unless custom products or nonstandard options are specified, provide standard products of types that have been produced and used successfully in similar situations on other projects.
 3. Owner reserves the right to limit selection to products with warranties not in conflict with requirements of the Contract Documents.
 4. Where products are accompanied by the term "as selected," Architect will make selection.
 5. Where products are accompanied by the term "match sample," sample to be matched is Architect's.
 6. Descriptive, performance, and reference standard requirements in the Specifications establish "salient characteristics" of products.
 7. Or Equal: Where products are specified by name and accompanied by the term "or equal" or "or approved equal" or "or approved," comply with provisions in "Comparable Products" Article to obtain approval for use of an unnamed product.

- B. Product Selection Procedures:** Procedures for product selection include the following:
1. **Product:** Where Specification paragraphs or subparagraphs titled "Product" name a single product and manufacturer, provide the product named.
 - a. Substitutions may be considered, unless otherwise indicated.
 2. **Manufacturer/Source:** Where Specification paragraphs or subparagraphs titled "Manufacturer" or "Source" name single manufacturers or sources, provide a product by the manufacturer or from the source named that complies with requirements.
 - a. Substitutions may be considered, unless otherwise indicated.
 3. **Products:** Where Specification paragraphs or subparagraphs titled "Products" introduce a list of names of both products and manufacturers, provide one of the products listed that complies with requirements.
 - a. Substitutions may be considered, unless otherwise indicated.
 4. **Manufacturers:** Where Specification paragraphs or subparagraphs titled "Manufacturers" introduce a list of manufacturers' names, provide a product by one of the manufacturers listed that complies with requirements.
 - a. Substitutions may be considered, unless otherwise indicated.
 5. **Available Products:** Where Specification paragraphs or subparagraphs titled "Available Products" introduce a list of names of both products and manufacturers, provide one of the products listed or another product that complies with requirements. Comply with provisions in "Comparable Products" Article to obtain approval for use of an unnamed product.
 6. **Available Manufacturers:** Where Specification paragraphs or subparagraphs titled "Available Manufacturers" introduce a list of manufacturers' names, provide a product by one of the manufacturers listed or another manufacturer that complies with requirements. Comply with provisions in "Comparable Products" Article to obtain approval for use of an unnamed product.
 7. **Product Options:** Where Specification paragraphs titled "Product Options" indicate that size, profiles, and dimensional requirements on Drawings are based on a specific product or system, provide either the specific product or system indicated or a comparable product or system by another manufacturer. Comply with provisions in "Product Substitutions" Article.
 8. **Basis-of-Design Products:** Where Specification paragraphs or subparagraphs titled "Basis-of-Design Products" are included and also introduce or refer to a list of manufacturers' names, provide either the specified product or a comparable product by one of the other named manufacturers. Drawings and Specifications indicate sizes, profiles, dimensions, and other characteristics that are based on the product named. Comply with provisions in "Comparable Products" Article to obtain approval for use of an unnamed product.
 - a. Substitutions may be considered, unless otherwise indicated.
 9. **Visual Matching Specification:** Where Specifications require matching an established Sample, select a product (and manufacturer) that complies with requirements and matches Architect's sample. Architect's decision will be final on whether a proposed product matches satisfactorily.
 - a. If no product available within specified category matches satisfactorily and complies with other specified requirements, comply with provisions of the Contract Documents on "substitutions" for selection of a matching product.
 10. **Visual Selection Specification:** Where Specifications include the phrase "as selected from manufacturer's colors, patterns, textures" or a similar phrase, select a product (and manufacturer) that complies with other specified requirements.
 - a. **Standard Range:** Where Specifications include the phrase "standard range of colors, patterns, textures" or similar phrase, Architect will select color, pattern, or texture from manufacturer's product line that does not include premium items.

- b. **Full Range:** Where Specifications include the phrase "full range of colors, patterns, textures" or similar phrase, Architect will select color, pattern, or texture from manufacturer's product line that includes both standard and premium items.

2.2 PRODUCT SUBSTITUTIONS

- A. **Timing:** Architect will consider requests for substitution if received within 60 days after the Notice to Proceed. Requests received after that time may be considered or rejected at discretion of Architect.

- B. **Conditions:** Architect will consider Contractor's request for substitution when the following conditions are satisfied. If the following conditions are not satisfied, Architect will return requests without action, except to record noncompliance with these requirements:
 - 1. Requested substitution offers Owner a substantial advantage in cost, time, energy conservation, or other considerations, after deducting additional responsibilities Owner must assume. Owner's additional responsibilities may include compensation to Architect for redesign and evaluation services, increased cost of other construction by Owner, and similar considerations.
 - 2. Requested substitution does not require extensive revisions to the Contract Documents.
 - 3. Requested substitution is consistent with the Contract Documents and will produce indicated results.
 - 4. Substitution request is fully documented and properly submitted.
 - 5. Requested substitution will not adversely affect Contractor's Construction Schedule.
 - 6. Requested substitution has received necessary approvals of authorities having jurisdiction.
 - 7. Requested substitution is compatible with other portions of the Work.
 - 8. Requested substitution has been coordinated with other portions of the Work.
 - 9. Requested substitution provides specified warranty.
 - 10. If requested substitution involves more than one contractor, requested substitution has been coordinated with other portions of the Work, is uniform and consistent, is compatible with other products, and is acceptable to all contractors involved.

2.3 COMPARABLE PRODUCTS

- A. **Where products** or manufacturers are specified by name, submit the following, in addition to other required submittals, to obtain approval of an unnamed product:
 - 1. Evidence that the proposed product does not require extensive revisions to the Contract Documents, that it is consistent with the Contract Documents and will produce the indicated results, and that it is compatible with other portions of the Work.
 - 2. Detailed comparison of significant qualities of proposed product with those named in the Specifications. Significant qualities include attributes such as performance, weight, size, durability, visual effect, and specific features and requirements indicated.
 - 3. Evidence that proposed product provides specified warranty.
 - 4. List of similar installations for completed projects with project names and addresses and names and addresses of architects and owners, if requested.
 - 5. Samples, if requested.

PART 3 - EXECUTION - NOT USED

END OF SECTION

SECTION 01 7300

EXECUTION

PART 1 - GENERAL

1.1 RELATED DOCUMENTS

- A. Drawings and general provisions of the Contract, including General and Supplementary Conditions and other Division 1 Specification Sections, apply to this Section.

1.2 SUMMARY

- A. **This Section includes** general procedural requirements governing **execution of the Work** including, but not limited to, the following:
 1. Construction layout.
 2. Field engineering and surveying.
 3. General installation of products.
 4. Progress cleaning.
 5. Starting and adjusting.
 6. Protection of installed construction.
 7. Correction of the Work.
- B. **Related Sections** include the following:
 1. Section 01 3100 "**Project Management and Coordination**" for procedures for coordinating field engineering with other construction activities.
 2. Section 01 3300 "**Submittal Procedures**" for administrative submittals and also product and procedural submittals.
 3. Section 01 7700 "**Closeout Procedures**" for submitting final property survey with Project Record Documents, recording of Owner-accepted deviations from indicated lines and levels, and final cleaning.

1.3 SUBMITTALS

- A. **Landfill Receipts:** Submit copy of receipts issued by a landfill facility, licensed to accept hazardous materials, for hazardous waste disposal.

PART 2 - PRODUCTS - NOT USED

PART 3 - EXECUTION

3.1 EXAMINATION

- A. **Existing Conditions:** The existence and location of site improvements, utilities, and other construction indicated as existing are not guaranteed. Before beginning work, investigate and verify the existence and location of mechanical and electrical systems and other construction affecting the Work.
 1. Before construction, verify the location and points of connection of utility services.

- B. **Existing Utilities:** The existence and location of underground and other utilities and construction indicated as existing are not guaranteed. Before beginning sitework, investigate and verify the existence and location of underground utilities and other construction affecting the Work.
1. Before construction, verify the location and invert elevation at points of connection of sanitary sewer, storm sewer, and water-service piping; and underground electrical services.
 2. Furnish location data for work related to Project that must be performed by public utilities serving Project site.
- C. **Acceptance of Conditions:** Examine substrates, areas, and conditions, with Installer or Applicator present where indicated, for compliance with requirements for installation tolerances and other conditions affecting performance. Record observations.
1. Written Report: Where a written report listing conditions detrimental to performance of the Work is required by other Sections, include the following:
 - a. Description of the Work.
 - b. List of detrimental conditions, including substrates.
 - c. List of unacceptable installation tolerances.
 - d. Recommended corrections.
 2. Verify compatibility with and suitability of substrates, including compatibility with existing finishes or primers.
 3. Examine roughing-in for mechanical and electrical systems to verify actual locations of connections before equipment and fixture installation.
 4. Examine walls, floors, and roofs for suitable conditions where products and systems are to be installed.
 5. Proceed with installation only after unsatisfactory conditions have been corrected. Proceeding with the Work indicates acceptance of surfaces and conditions.

3.2 PREPARATION

- A. **Existing Utility Interruptions:** Do not interrupt utilities serving facilities occupied unless permitted under the following conditions and then only after arranging to provide temporary utility services according to requirements indicated:
1. Notify Architect and Owner not less than two business days in advance of proposed utility interruptions.
 2. Do not proceed with utility interruptions without Architect's and Owner's written permission.
- B. **Field Measurements:** Take field measurements as required to fit the Work properly. Recheck measurements before installing each product. Where portions of the Work are indicated to fit to other construction, verify dimensions of other construction by field measurements before fabrication. Coordinate fabrication schedule with construction progress to avoid delaying the Work.
- C. **Space Requirements:** Verify space requirements and dimensions of items shown diagrammatically on Drawings.
- D. **Review of Contract Documents and Field Conditions:** Immediately on discovery of the need for clarification of the Contract Documents, submit a request for information to Architect. Include a detailed description of problem encountered, together with recommendations for changing the Contract Documents.

3.3 CONSTRUCTION LAYOUT

- A. **Verification:** Before proceeding to lay out the Work, verify layout information shown on Drawings, in relation to the property survey and existing benchmarks. If discrepancies are discovered, notify Architect promptly.

3.4 FIELD ENGINEERING

- A. **Identification:** Owner will identify existing benchmarks, control points, and property corners.
- B. **Reference Points:** Locate existing permanent benchmarks, control points, and similar reference points before beginning the Work. Preserve and protect permanent benchmarks and control points during construction operations.
 - 1. Do not change or relocate existing benchmarks or control points without prior written approval of Architect. Report lost or destroyed permanent benchmarks or control points promptly. Report the need to relocate permanent benchmarks or control points to Architect before proceeding.
 - 2. Replace lost or destroyed permanent benchmarks and control points promptly. Base replacements on the original survey control points.

3.5 INSTALLATION

- A. **General:** Locate the Work and components of the Work accurately, in correct alignment and elevation, as indicated.
 - 1. Make vertical work plumb and make horizontal work level.
 - 2. Where space is limited, install components to maximize space available for maintenance and ease of removal for replacement.
 - 3. Conceal pipes, ducts, and wiring in finished areas, unless otherwise indicated.
 - 4. Maintain minimum headroom clearance as indicated in spaces without a suspended ceiling.
- B. **Comply with manufacturer's written instructions** and recommendations for installing products in applications indicated.
- C. **Install products** at the time and under conditions that will ensure the best possible results. Maintain conditions required for product performance until Substantial Completion.
- D. **Conduct construction operations** so no part of the Work is subjected to damaging operations or loading in excess of that expected during normal conditions of occupancy.
- E. **Tools and Equipment:** Do not use tools or equipment that produce harmful noise levels.
- F. **Anchors and Fasteners:** Provide anchors and fasteners as required to anchor each component securely in place, accurately located and aligned with other portions of the Work.
 - 1. **Mounting Heights:** Where mounting heights are not indicated, mount components at heights directed by Architect.
 - 2. Allow for building movement, including thermal expansion and contraction.
- G. **Joints:** Make joints of uniform width. Where joint locations in exposed work are not indicated, arrange joints for the best visual effect. Fit exposed connections together to form hairline joints.

- H. **Hazardous Materials:** Use products, cleaners, and installation materials that are not considered hazardous.

3.6 PROGRESS CLEANING

- A. **General:** Clean Project site and work areas daily, including common areas. Coordinate progress cleaning for joint-use areas where more than one installer has worked. Enforce requirements strictly. Dispose of materials lawfully.
1. Comply with requirements in NFPA 241 for removal of combustible waste materials and debris.
 2. Do not hold materials more than 7 days during normal weather or 3 days if the temperature is expected to rise above 80 degrees F.
 3. Containerize hazardous and unsanitary waste materials separately from other waste. Mark containers appropriately and dispose of legally, according to regulations.
- B. **Site:** Maintain Project site free of waste materials and debris.
- C. **Work Areas:** Clean areas where work is in progress to the level of cleanliness necessary for proper execution of the Work.
1. Remove liquid spills promptly.
 2. Where dust would impair proper execution of the Work, broom-clean or vacuum the entire work area, as appropriate.
- D. **Installed Work:** Keep installed work clean. Clean installed surfaces according to written instructions of manufacturer or fabricator of product installed, using only cleaning materials specifically recommended. If specific cleaning materials are not recommended, use cleaning materials that are not hazardous to health or property and that will not damage exposed surfaces.
- E. **Concealed Spaces:** Remove debris from concealed spaces before enclosing the space.
- F. **Exposed Surfaces:** Clean exposed surfaces and protect as necessary to ensure freedom from damage and deterioration at time of Substantial Completion.
- G. **Cutting and Patching:** Clean areas and spaces where cutting and patching are performed. Completely remove paint, mortar, oils, putty, and similar materials.
1. Thoroughly clean piping, conduit, and similar features before applying paint or other finishing materials. Restore damaged pipe covering to its original condition.
- H. **Waste Disposal:** Burying or burning waste materials on-site will not be permitted. Washing waste materials down sewers or into waterways will not be permitted.
- I. **Protection:** During handling and installation, clean and protect construction in progress and adjoining materials already in place. Apply protective covering where required to ensure protection from damage or deterioration at Substantial Completion.
- J. **Maintenance:** Clean and provide maintenance on completed construction as frequently as necessary through the remainder of the construction period. Adjust and lubricate operable components to ensure smooth operation without damaging effects.
- K. **Limiting Exposures:** Supervise construction operations to assure that no part of the construction, completed or in progress, is subject to harmful, dangerous, damaging, or otherwise deleterious exposure during the construction period.

3.7 DUST CONTROL

- A. **Provide continuous (7 days per week, 24 hours per day) fugitive dust control measures** within the limits of the construction site, related sites and adjacent streets and roads. Dust control shall be provided for, but not be specifically limited to, the stabilization of unpaved roads, haul roads, access roads, spoil sites, borrow and material sources, excavations, embankments, stockpiles, and all other areas which become potential sources of dust as a result of construction activities.
- B. **Maintain compliance with the General Utah Air Pollution Regulations**, R446 - Utah Air Conservation Regulations, Section 4.5, Fugitive Emissions, applicable County Air Pollution Control Ordinances, and as directed by the Architect. Dust control measures shall include but not be limited to the following:
 - 1. Wetting of surfaces with water as appropriate.
 - 2. Minimizing surface disturbances.
- C. **In order to control fugitive dust emissions**, apply the following procedures and techniques:
 - 1. Cover loads of materials, debris and waste materials taken from construction sites as needed to suppress dust during transit.
 - 2. Water down or apply other approved dust control measures to the construction site, haul roads and public access roads as needed to suppress dust.
 - 3. Remove mud and dirt from vehicles prior to entering a paved or graveled area or road. Any mud or dirt that is carried out onto paved or graveled surfaces shall be removed from surfaces immediately and no less than daily.

3.8 STARTING AND ADJUSTING

- A. **Start equipment** and operating components to confirm proper operation. Remove malfunctioning units, replace with new units, and retest.
- B. **Adjust operating components** for proper operation without binding. Adjust equipment for proper operation.
- C. **Test each piece** of equipment to verify proper operation. Test and adjust controls and safeties. Replace damaged and malfunctioning controls and equipment.
- D. **Manufacturer's Field Service:** If a factory-authorized service representative is required to inspect field-assembled components and equipment installation, comply with qualification requirements in Division 1 Section "Quality Requirements."

3.9 PROTECTION OF INSTALLED CONSTRUCTION

- A. **Provide final protection** and maintain conditions that ensure installed Work is without damage or deterioration at time of Substantial Completion.
- B. **Comply with manufacturer's written instructions** for temperature and relative humidity.

3.10 CORRECTION OF THE WORK

- A. **Repair or remove** and replace defective construction. Restore damaged substrates and finishes. Comply with requirements in Division 2 Section "Cutting and Patching."
 - 1. Repairing includes replacing defective parts, refinishing damaged surfaces, touching up with matching materials, and properly adjusting operating equipment.

- B. **Restore permanent facilities** used during construction to their specified condition.
- C. **Remove and replace damaged surfaces** that are exposed to view if surfaces cannot be repaired without visible evidence of repair.
- D. **Repair components** that do not operate properly. Remove and replace operating components that cannot be repaired.
- E. **Remove and replace** chipped, scratched, and broken glass or reflective surfaces.

END OF SECTION



CONSTRUCTION SAFETY REQUIREMENTS

- I. Outside Contractors and Intermountain Construction Employees performing construction activities on occupied Intermountain Healthcare property shall meet the following requirements. Stand-alone, new construction sites are not covered by these requirements. Outside Contractors will meet additional qualifications through the Supply Chain Organization Supplier Credentialing Procedure.
 - a. No work will be performed in any Intermountain Facility without prior approval and coordination with the accountable Facility Engineering Manager or Director.
 - b. Each outside contractor will have a Safety Program that complies with 29 CFR 1926 Subpart C. The Safety Program will be in writing.
 - c. Any chemical brought onto Intermountain Property must meet the following requirements:
 - i. Approved by the facility's Chemical Safety Officer,
 - ii. Accompanied by a current material safety data sheet,
 - iii. Stored in accordance with the chemical manufacturer's safety requirements in the appropriate labeled container.
 - iv. Where the chemical quantity is restricted for Healthcare Occupancies by NFPA 30 or other standards, it is the contractor's responsibility to provide for off-site storage.
 - v. The Contractor is responsible to comply with Intermountain's Hazardous Materials policy.
 - vi. The Contractor is responsible for the removal of all chemicals from Intermountain Property and for proper disposal in accordance with applicable laws and regulations.
 - d. No work will be performed without the completion of an Interim Life Safety and Infection Control Risk Assessment. These risk assessments will cover each phase of the construction project.
 - e. In existing facilities, an Asbestos inspection and any necessary abatement will be conducted prior to any renovation or remodel per the Hazmat policy.
 - f. Where work will cause noise or vibration, an assessment will be made following facility procedures to mitigate potential hazards to patients.
 - g. Above the Ceiling Permits
 - i. The Contractor will follow each facility's procedure for obtaining an above the ceiling work permit.
 - ii. No work will be performed prior to obtaining this permit.
 - h. Hot Work Permits
 - i. The Contractor will obtain a Hot Work Permit from Facilities Engineering prior to performing any hot work.
 - ii. The Contractor will provide a continuous and qualified fire watch for the duration and location specified by the Facility Engineering Director.
 - i. Confined Space Permits
 - i. The contractor will coordinate with the Intermountain Facility Engineering Director to assure that all requirements are met and a permit is completed prior to entering a permit required confined space.

- j. Control of Airborne Contaminants
 - i. The contractor will control all airborne dusts, mists, fumes, and vapors such that there is no exposure to Intermountain employees, patients, or visitors. This includes the generation of contaminants outside the building.
 - ii. If necessary, work will be conducted after hours to minimize potential exposures to staff, patients, and members of the public.
- k. Personal Protective Equipment.
 - i. PPE for head, eye, face, hand, foot, and respiratory protection is the responsibility of the contractor, and will be provided and worn as necessary for the exposure, except as follows:
 - 1. Hard Hats and Safety Glasses are required to be worn at all times when in the construction area. Hard hats may be removed when working in areas where the suspended ceiling grid has been completely installed.
 - ii. Fall Protection is the responsibility of the contractors and shall meet all 29 CFR 1926 requirements of the applicable Subparts.

SECTION 01 7329

CUTTING AND PATCHING

PART 1 - GENERAL

1.1 RELATED DOCUMENTS

- A. Drawings and general provisions of the Contract, including General and Supplementary Conditions and other Division 1 Specification Sections, apply to this Section.

1.2 SUMMARY

- A. **This Section includes** procedural requirements for cutting and patching.
- B. **The General Contractor** is responsible to patch and repair any and all material disturbed during construction, this is to include but not limited to walls, floors, ceilings, asphalt, concrete, lawns and landscaping, roofs, etc.

1.3 DEFINITION

- A. **Cutting:** Removal of existing construction necessary to permit installation or performance of other Work.
- B. **Patching:** Fitting and repair work required to restore surfaces to original conditions after installation of other Work.

1.4 SUBMITTALS

- A. **Cutting and Patching Proposal:** Submit a proposal describing procedures at least 10 days before the time cutting and patching will be performed, requesting approval to proceed.
 - 1. **Architect's Approval:** Obtain approval of cutting and patching proposal before cutting and patching. Approval does not waive right to later require removal and replacement of unsatisfactory work.

1.5 QUALITY ASSURANCE

- A. **Structural Elements:** Do not cut and patch structural elements in a manner that could change their load-carrying capacity or load-deflection ratio.
- B. **Operational Elements:** Do not cut and patch operating elements and related components in a manner that results in reducing their capacity to perform as intended or that results in increased maintenance or decreased operational life or safety, including but not limited to the following:
 - 1. Primary operational systems and equipment.
 - 2. Fire-protection systems.
 - 3. Communication systems.
 - 4. Electrical wiring systems.
- C. **Miscellaneous Elements:** Do not cut and patch the following elements or related components in a manner that could change their load-carrying capacity, that results in reducing their capacity to perform as intended, or that results in increased maintenance or decreased operational life or safety.
 - 1. Piping, ductwork, vessels, and equipment.

- D. **Visual Requirements:** Do not cut and patch construction in a manner that results in visual evidence of cutting and patching. Do not cut and patch construction exposed on the exterior or in occupied spaces in a manner that would, in Architect's opinion, reduce the building's aesthetic qualities. Remove and replace construction that has been cut and patched in a visually unsatisfactory manner.
1. If possible, retain original Installer or fabricator to cut and patch exposed Work. If it is impossible to engage original Installer or fabricator, engage another recognized, experienced, and specialized firm.
- E. **Cutting and Patching Conference:** Before proceeding, meet at Project site with parties involved in cutting and patching, including mechanical and electrical trades. Review areas of potential interference and conflict. Coordinate procedures and resolve potential conflicts before proceeding.

1.6 WARRANTY

- A. **Existing Warranties:** Remove, replace, patch, and repair materials and surfaces cut or damaged during cutting and patching operations, by methods and with materials so as not to void existing warranties.

PART 2 - PRODUCTS

2.1 MATERIALS

- A. **General:** Comply with requirements specified in other Sections of these Specifications.
- B. **Existing Materials:** Use materials identical to existing materials. For exposed surfaces, use materials that visually match existing adjacent surfaces to the fullest extent possible.
1. If identical materials are unavailable or cannot be used, use materials that, when installed, will match the visual and functional performance of existing materials.

PART 3 - EXECUTION

3.1 EXAMINATION

- A. **Examine surfaces** to be cut and patched and conditions under which cutting and patching are to be performed.
1. **Compatibility:** Before patching, verify compatibility with and suitability of substrates, including compatibility with existing finishes or primers.
 2. Proceed with installation only after unsafe or unsatisfactory conditions have been corrected.

3.2 PREPARATION

- A. **Temporary Support:** Provide temporary support of Work to be cut.
- B. **Protection:** Protect existing construction during cutting and patching to prevent damage. Provide protection from adverse weather conditions for portions of Project that might be exposed during cutting and patching operations.
- C. **Adjoining Areas:** Avoid interference with use of adjoining areas or interruption of free passage to adjoining areas.

- D. **Existing Services:** Where existing services are required to be removed, relocated, or abandoned, bypass such services before cutting to minimize interruption of services to occupied areas.

3.3 PERFORMANCE

- A. **General:** Employ skilled workers to perform cutting and patching. Proceed with cutting and patching at the earliest feasible time, and complete without delay.
1. Cut existing construction to provide for installation of other components or performance of other construction, and subsequently patch as required to restore surfaces to their original condition.
- B. **Cutting:** Cut existing construction by sawing, drilling, breaking, chipping, grinding, and similar operations, including excavation, using methods least likely to damage elements retained or adjoining construction. If possible, review proposed procedures with original Installer; comply with original Installer's written recommendations.
1. **General:** use hand or small power tools designed for sawing and grinding, not hammering and chopping. Cut holes and slots as small as possible, neatly to size required, and with minimum disturbance of adjacent surfaces. Temporarily cover openings when not in use.
 2. **Existing Finished Surfaces:** Cut or drill from the exposed or finished side into concealed surfaces.
 3. **Concrete/Masonry:** Cut using a cutting machine, such as an abrasive saw or a diamond-core drill.
 4. **Mechanical and Electrical Services:** Cut off pipe or conduit to be removed. Cap, valve, or plug and seal remaining portion of pipe or conduit to prevent entrance of moisture or other foreign matter after cutting.
 5. **Patching:** Proceed with patching after construction operations requiring cutting are complete.
- C. **Patching:** Patch construction by filling, repairing, refinishing, closing up, and similar operations following performance of other Work. Patch with durable seams that are as invisible as possible. Patch masonry with masonry units and grout that match as closely as possible the original. Provide materials and comply with installation requirements specified in other Sections of these Specifications.
1. **Fireproofing:** Restore fireproofing coatings to original thickness and fire resistance.
 2. **Inspection:** Where feasible, test and inspect patched areas after completion to demonstrate integrity of installation.
 3. **Exposed Finishes:** Restore exposed finishes of patched areas and extend finish restoration into retained adjoining construction in a manner that will eliminate evidence of patching and refinishing.

END OF SECTION

THIS PAGE LEFT BLANK INTENTIONALLY

SECTION 01 7700

CLOSEOUT PROCEDURES

PART 1 - GENERAL

1.1 RELATED DOCUMENTS

- A. Drawings and general provisions of the Contract, including General and Supplementary Conditions and other Division 1 Specification Sections, apply to this Section.

1.2 SUMMARY

- A. **This Section includes** administrative and procedural requirements for contract closeout, including, but not limited to, the following:
1. Inspection procedures.
 2. Project Record Documents.
 3. Operation and maintenance manuals.
 4. Warranties.
 5. Instruction of Owner's personnel.
 6. Final cleaning.
- B. **Related Sections** include the following:
1. Section 01 2900 "**Payment Procedures**" for requirements for Applications for Payment for Substantial and Final Completion.
 2. Section 01 7300 "**Execution**" for progress cleaning of Project site.
 3. **Divisions 2 through 49** Sections for specific closeout and special cleaning requirements for products of those Sections.

1.3 SUBSTANTIAL COMPLETION

- A. **Preliminary Procedures:** Before requesting inspection for determining date of Substantial Completion, complete the following. List items below that are incomplete in request.
1. Prepare a list of items to be completed and corrected (punch list), the value of items on the list, and reasons why the Work is not complete.
 2. Advise Owner of pending insurance changeover requirements.
 3. Submit specific warranties, workmanship bonds, maintenance service agreements, final certifications, and similar documents.
 4. Obtain and submit releases permitting Owner unrestricted use of the Work and access to services and utilities. Include occupancy permits, operating certificates, and similar releases.
 5. Prepare and submit Project Record Documents, operation and maintenance manuals, Final Completion construction photographs, damage or settlement surveys, property surveys, and similar final record information.
 6. Deliver tools, spare parts, extra materials, and similar items to location designated by Owner. Label with manufacturer's name and model number where applicable.
 7. Make final changeover of permanent locks and deliver keys to Owner. Advise Owner's personnel of changeover in security provisions.
 8. Complete startup testing of systems.
 9. Submit test/adjust/balance records.
 10. Terminate and remove temporary facilities from Project site, along with mockups, construction tools, and similar elements.
 11. Advise Owner of changeover in heat and other utilities.
 12. Submit changeover information related to Owner's occupancy, use, operation, and maintenance.

13. Complete final cleaning requirements, including touchup painting.
 14. Touch up and otherwise repair and restore marred exposed finishes to eliminate visual defects.
- B. **Inspection:** Submit a written request for inspection for Substantial Completion. On receipt of request, Architect will either proceed with inspection or notify Contractor of unfulfilled requirements. Architect will prepare the Certificate of Substantial Completion after inspection or will notify Contractor of items, either on Contractor's list or additional items identified by Architect, that must be completed or corrected before certificate will be issued.
1. **Reinspection:** Request reinspection when the Work identified in previous inspections as incomplete is completed or corrected.
 2. Results of completed inspection will form the basis of requirements for Final Completion.

1.4 FINAL COMPLETION

- A. **Preliminary Procedures:** Before requesting final inspection for determining date of Final Completion, complete the following:
1. Submit a final Application for Payment according to Division 1 Section "Payment Procedures."
 2. Submit certified copy of Architect's Substantial Completion inspection list of items to be completed or corrected (punch list), endorsed and dated by Architect. The certified copy of the list shall state that each item has been completed or otherwise resolved for acceptance.
 3. Submit evidence of final, continuing insurance coverage complying with insurance requirements.
 4. Submit pest-control final inspection report and warranty.
 5. Instruct Owner's personnel in operation, adjustment, and maintenance of products, equipment, and systems.
- B. **Inspection:** Submit a written request for final inspection for acceptance. On receipt of request, Architect will either proceed with inspection or notify Contractor of unfulfilled requirements. Architect will prepare a final Certificate for Payment after inspection or will notify Contractor of construction that must be completed or corrected before certificate will be issued.
1. **Reinspection:** Request reinspection when the Work identified in previous inspections as incomplete is completed or corrected.
- C. **Additional Review Fees:** Should Architect perform more than one additional review, or extend its construction period services more than 15 business days beyond the scheduled completion date, due to the failure of the Contractor's work to comply with the claims of status or completion made by the Contractor, Owner will compensate Architect for such additional/ extended services at the rate of \$500.00 per day. The Owner shall then deduct the amount of such compensation from the final payment to the Contractor.

1.5 LIST OF INCOMPLETE ITEMS (PUNCH LIST)

- A. **Preparation:** Submit three copies of Contractors list. Include name and identification of each space and area affected by construction operations for incomplete items and items needing correction including, if necessary, areas disturbed by Contractor that are outside the limits of construction.
1. Organize list of spaces in sequential order, starting with exterior areas first and proceeding from lowest floor to highest floor.
 2. Organize items applying to each space by major element, including categories for ceiling, individual walls, floors, equipment, and building systems.

3. Include the following information at the top of each page:
 - a. Project name.
 - b. Date.
 - c. Name of Architect.
 - d. Name of Contractor.
 - e. Page number.

1.6 PROJECT RECORD DOCUMENTS

- A. **General:** Do not use Project Record Documents for construction purposes. Protect Project Record Documents from deterioration and loss. Provide access to Project Record Documents for Architect's reference during normal working hours.
- B. **Record Drawings:** Maintain and submit one set of blue- or black-line white prints of Contract Drawings and Shop Drawings.
 1. Mark Record Prints to show the actual installation where installation varies from that shown originally. Require individual or entity who obtained record data, whether individual or entity is Installer, subcontractor, or similar entity, to prepare the marked-up Record Prints.
 - a. Give particular attention to information on concealed elements that cannot be readily identified and recorded later.
 - b. Accurately record information in an understandable drawing technique.
 - c. Record data as soon as possible after obtaining it. Record and check the markup before enclosing concealed installations.
 - d. Mark Contract Drawings or Shop Drawings, whichever is most capable of showing actual physical conditions, completely and accurately. Where Shop Drawings are marked, show cross-reference on Contract Drawings.
 2. Mark record sets with erasable, red-colored pencil. Use other colors to distinguish between changes for different categories of the Work at the same location.
 3. Mark important additional information that was either shown schematically or omitted from original Drawings.
 4. Note Construction Change Directive numbers, Change Order numbers, alternate numbers, and similar identification where applicable.
 5. Identify and date each Record Drawing; include the designation "PROJECT RECORD DRAWING" in a prominent location. Organize into manageable sets; bind each set with durable paper cover sheets. Include identification on cover sheets.
- C. **Record Specifications:** Submit one copy of Project's Specifications, including addenda and contract modifications. Mark copy to indicate the actual product installation where installation varies from that indicated in Specifications, addenda, and contract modifications.
 1. Give particular attention to information on concealed products and installations that cannot be readily identified and recorded later.
 2. Mark copy with the proprietary name and model number of products, materials, and equipment furnished, including substitutions and product options selected.
 3. Note related Change Orders, Record Drawings, and Product Data, where applicable.

- D. **Record Product Data:** Submit one copy of each Product Data submittal. Mark one set to indicate the actual product installation where installation varies substantially from that indicated in Product Data.
1. Give particular attention to information on concealed products and installations that cannot be readily identified and recorded later.
 2. Include significant changes in the product delivered to Project site and changes in manufacturer's written instructions for installation.
 3. Note related Change Orders, Record Drawings, and Record Specifications, where applicable.
- E. **Miscellaneous Record Submittals:** Assemble miscellaneous records required by other Specification Sections for miscellaneous record keeping and submittal in connection with actual performance of the Work. Bind or file miscellaneous records and identify each, ready for continued use and reference.

1.7 OPERATION AND MAINTENANCE MANUALS

- A. **Assemble a complete set of operation and maintenance data** indicating the operation and maintenance of each system, subsystem, and piece of equipment not part of a system. Include operation and maintenance data required in individual Specification Sections and as follows:
1. Operation Data:
 - a. Emergency instructions and procedures.
 - b. System, subsystem, and equipment descriptions, including operating standards.
 - c. Operating procedures, including startup, shutdown, seasonal, and weekend operations.
 - d. Description of controls and sequence of operations.
 - e. Piping diagrams.
 2. Maintenance Data:
 - a. Manufacturer's information, including list of spare parts.
 - b. Name, address, and telephone number of Installer or supplier.
 - c. Maintenance procedures.
 - d. Maintenance and service schedules for preventive and routine maintenance.
 - e. Maintenance record forms.
 - f. Sources of spare parts and maintenance materials.
 - g. Copies of maintenance service agreements.
 - h. Copies of warranties and bonds.
- B. **Organize operation and maintenance manuals** into suitable sets of manageable size. Bind and index data in heavy-duty, 3-ring, vinyl-covered, loose-leaf binders, in thickness necessary to accommodate contents, with pocket inside the covers to receive folded oversized sheets. Identify each binder on front and spine with the printed title "OPERATION AND MAINTENANCE MANUAL," Project name, and subject matter of contents.

1.8 WARRANTIES

- A. **Submittal Time:** Submit written warranties on request of Architect for designated portions of the Work where commencement of warranties other than date of Substantial Completion is indicated.

- B. **Organize warranty documents** into an orderly sequence based on the table of contents of the Project Manual.
1. Bind warranties and bonds in heavy-duty, 3-ring, vinyl-covered, loose-leaf binders, thickness as necessary to accommodate contents, and sized to receive 8-1/2-by-11-inch paper.
 2. Provide heavy paper dividers with plastic-covered tabs for each separate warranty. Mark tab to identify the product or installation. Provide a typed description of the product or installation, including the name of the product and the name, address, and telephone number of Installer.
 3. Identify each binder on the front and spine with the typed or printed title "WARRANTIES," Project name, and name of Contractor.
- C. **Provide additional copies** of each warranty to include in operation and maintenance manuals.

PART 2 - PRODUCTS

2.1 MATERIALS

- A. **Cleaning Agents:** Use cleaning materials and agents recommended by manufacturer or fabricator of the surface to be cleaned. Do not use cleaning agents that are potentially hazardous to health or property or that might damage finished surfaces.

PART 3 - EXECUTION

3.1 DEMONSTRATION AND TRAINING

- A. **Instruction:** Instruct Owner's personnel to adjust, operate, and maintain systems, subsystems, and equipment not part of a system.
1. Provide instructors experienced in operation and maintenance procedures.
 2. Provide instruction at mutually agreed-on times. For equipment that requires seasonal operation, provide similar instruction at the start of each season.
 3. Schedule training with Owner, through Architect, with at least seven days' advance notice.
 4. Coordinate instructors, including providing notification of dates, times, length of instruction, and course content.
- B. **Program Structure:** Develop an instruction program that includes individual training modules for each system and equipment not part of a system, as required by individual Specification Sections. For each training module, develop a learning objective and teaching outline. Include instruction for the following:
1. System design and operational philosophy.
 2. Review of documentation.
 3. Operations.
 4. Adjustments.
 5. Troubleshooting.
 6. Maintenance.
 7. Repair.

3.2 FINAL CLEANING

- A. **General:** Provide final cleaning. Conduct cleaning and waste-removal operations to comply with local laws and ordinances and Federal and local environmental and antipollution regulations.

- B. Cleaning:** Employ experienced workers or professional cleaners for final cleaning. Clean each surface or unit to condition expected in an average commercial building cleaning and maintenance program. Comply with manufacturer's written instructions.
1. Complete the following cleaning operations before requesting inspection for certification of Substantial Completion for entire Project or for a portion of Project:
 - a. Clean Project site, yard, and grounds, in areas disturbed by construction activities, including landscape development areas, of rubbish, waste material, litter, and other foreign substances.
 - b. Sweep paved areas broom clean. Remove petrochemical spills, stains, and other foreign deposits.
 - c. Rake grounds that are neither planted nor paved to a smooth, even-textured surface.
 - d. Remove tools, construction equipment, machinery, and surplus material from Project site.
 - e. Remove snow and ice to provide safe access to building.
 - f. Clean exposed exterior and interior hard-surfaced finishes to a dirt-free condition, free of stains, films, and similar foreign substances. Avoid disturbing natural weathering of exterior surfaces. Restore reflective surfaces to their original condition.
 - 1) Use low VOC and low emitting cleaning products to the maximum extent feasible.
 - g. Remove debris and surface dust from limited access spaces, including roofs, plenums, shafts, trenches, equipment vaults, manholes, attics, and similar spaces.
 - h. Sweep concrete floors broom clean in unoccupied spaces.
 - i. Vacuum carpet and similar soft surfaces, removing debris and excess nap; shampoo if visible soil or stains remain.
 - j. Clean transparent materials, including mirrors and glass in doors and windows. Remove glazing compounds and other noticeable, vision-obscuring materials. Replace chipped or broken glass and other damaged transparent materials. Polish mirrors and glass, taking care not to scratch surfaces.
 - k. Remove labels that are not permanent.
 - l. Touch up and otherwise repair and restore marred, exposed finishes and surfaces. Replace finishes and surfaces that cannot be satisfactorily repaired or restored or that already show evidence of repair or restoration.
 - 1) Do not paint over "UL" and similar labels, including mechanical and electrical nameplates.
 - m. Wipe surfaces of mechanical and electrical equipment, elevator equipment, and similar equipment. Remove excess lubrication, paint and mortar droppings, and other foreign substances.
 - n. Replace parts subject to unusual operating conditions.
 - o. Clean plumbing fixtures to a sanitary condition, free of stains, including stains resulting from water exposure.
 - p. Replace disposable air filters and clean permanent air filters. Clean exposed surfaces of diffusers, registers, and grills.
 - q. Clean ducts, blowers, and coils if units were operated without filters during construction.
 - r. Clean light fixtures, lamps, globes, and reflectors to function with full efficiency. Replace burned-out bulbs, and those noticeably dimmed by hours of use, and defective and noisy starters in fluorescent and mercury vapor fixtures to comply with requirements for new fixtures.
 - s. Leave Project clean and ready for occupancy.

- C. **Cleaning Standards:** Comply with safety standards for cleaning. Do not burn waste materials. Do not bury debris or excess materials on Owner's property. Do not discharge volatile, harmful, or dangerous materials into drainage systems. Remove waste materials from Project site and dispose of lawfully.

END OF SECTION

THIS PAGE LEFT BLANK INTENTIONALLY

INTERMOUNTAIN HEALTHCARE

RECORD DRAWING REQUIREMENTS

PROJECT CONTRACT NAME: Project Contract Name

ARCHITECTURAL FIRM: Architect Firm ARCH. PROJECT NO: ##

CONTRACTOR: Contractor

*Record Drawings are required per the Owner / Architect contract agreement and shall consist of AutoCAD files (.dwg), BIM files (i.e. REVIT [.rvt], etc.), PDF (.pdf) files, Sheet Index (.xls), Renderings/Photos and Specifications as outlined below. Drawing files shall be separated into individual files with all external references (xrefs) and attached files (i.e. images, special fonts, pen settings, etc.) bound to each separate drawing. The AutoCAD, BIM and PDF files can be included under each discipline below in separate folders. Naming of these files shall be sequential and as outlined on the Architects Drawing Index. The file names shall not include any special characters and/or symbols (i.e. \, /, :, *, ?, ", <, >, |, #, {, }, %, ~, &, etc.). **By submitting Record Drawings to the Owner, Architect has verified that all content is functional and readable.***

RECORD DRAWING SHEET INDEX Provide an Excel File (.xls) of complete drawing index.

RECORD DRAWING DISCIPLINES	AUTOCAD (.dwg)	REVIT (.rvt)	PDF (.pdf)
ARCHITECTURAL.....	<input checked="" type="checkbox"/>	<input checked="" type="checkbox"/>	<input checked="" type="checkbox"/>
CIVIL.....	<input checked="" type="checkbox"/>	<input checked="" type="checkbox"/>	<input checked="" type="checkbox"/>
LANDSCAPE.....	<input checked="" type="checkbox"/>	<input checked="" type="checkbox"/>	<input checked="" type="checkbox"/>
STRUCTURAL.....	<input checked="" type="checkbox"/>	<input checked="" type="checkbox"/>	<input checked="" type="checkbox"/>
PLUMBING.....	<input checked="" type="checkbox"/>	<input checked="" type="checkbox"/>	<input checked="" type="checkbox"/>
MECHANICAL.....	<input checked="" type="checkbox"/>	<input checked="" type="checkbox"/>	<input checked="" type="checkbox"/>
ELECTRICAL.....	<input checked="" type="checkbox"/>	<input checked="" type="checkbox"/>	<input checked="" type="checkbox"/>
_____.....	<input checked="" type="checkbox"/>	<input checked="" type="checkbox"/>	<input checked="" type="checkbox"/>
_____.....	<input checked="" type="checkbox"/>	<input checked="" type="checkbox"/>	<input checked="" type="checkbox"/>
_____.....	<input checked="" type="checkbox"/>	<input checked="" type="checkbox"/>	<input checked="" type="checkbox"/>
_____.....	<input checked="" type="checkbox"/>	<input checked="" type="checkbox"/>	<input checked="" type="checkbox"/>

RECORD SPECIFICATIONS Separate into Divisions / Sections with T.O.C. (.pdf)

RENDERINGS | PHOTOS

REVIEWED BY: Architect DATE REVIEWED: 10/10/2012

SIGNATURE: _____

*This document is to be included in Division I specifications and kept with the Record Drawing file.

THIS PAGE LEFT BLANK INTENTIONALLY

DIVISION 02 – EXISTING CONDITIONS

Section 02 4102

Selective Demolition

THIS PAGE LEFT BLANK INTENTIONALLY

SECTION 02 4102

SELECTIVE DEMOLITION

PART 1 - GENERAL

1.1 RELATED DOCUMENTS

- A. Drawings and general provisions of the Contract, including General and Supplementary Conditions and other Division 1 Specification Sections, apply to this Section.

1.2 SUMMARY

- A. **This Section includes** the following:
 - 1. Demolition and removal of selected portions of a building or structure.
 - 2. Repair procedures for selective demolition operations.
- B. **Related Sections** include the following:
 - 1. Section 01 7329 "**Cutting and Patching**" for cutting and patching procedures for selective demolition operations.

1.3 DEFINITIONS

- A. **Deconstruction:** Disassembly of buildings for the purpose of recovering materials
- B. **Demolish:** Completely remove and legally dispose of off-site.
- C. **Existing to Remain or Retain:** Existing items of construction that are not to be removed and that are not otherwise indicated to be removed and salvaged, or removed and reinstalled
- D. **Protect:** Except as otherwise defined in greater detail, the term "protect" is used to describe the process of shielding from harm existing fixtures, elements or materials.
- E. **Protect and Maintain:** To remove deteriorating corrosion, reapply protective coatings, and install protective measures such as temporary guards; to provide the least degree of intervention.
- F. **Recycle:** Recovery of demolition waste for subsequent processing in preparation for reuse.
- G. **Remove:** To detach items from existing construction and legally dispose of them off-site unless indicated to be removed and salvaged or removed and reinstalled.
- H. **Remove and Salvage:** To detach items from existing construction and deliver them to Owner ready for reuse.
- I. **Remove and Reinstall:** To detach items from existing construction, repair and clean them for reuse, and reinstall them where indicated.
- J. **Salvage:** Carefully detach from existing construction, in a manner to prevent damage, and deliver to Owner. Include fasteners or brackets needed for reattachment elsewhere.

- K. **Stabilize:** To apply measures designed to reestablish a weather-resistant enclosure and the structural reinforcement of an item or portion of the building while maintaining the essential form as it exists at present.

1.4 MATERIALS OWNERSHIP

- A. **Historic items, relics, and similar objects** including, but not limited to, cornerstones and their contents, commemorative plaques and tablets, antiques, and other items of interest or value to Owner that may be encountered during selective demolition remain Owner's property. Carefully remove and salvage each item or object in a manner to prevent damage and deliver promptly to Owner.

1.5 SUBMITTALS

- A. **Qualification Data:** For firms and persons specified in "Quality Assurance" Article to demonstrate their capabilities and experience. Include lists of completed projects with project names and addresses, names and addresses of architects and owners, and other information specified.
- B. **Proposed Dust-Control and Noise-Control Measures:** Submit statement or drawing that indicates the measures proposed for use, proposed locations, and proposed time frame for their operation. Identify options if proposed measures are later determined to be inadequate.
- C. **Schedule of items and materials to be salvaged:** Identify procedures for disassembly.
1. Identify materials to be recycled. Identify materials to be salvaged for reuse on site and off site.
- D. **Schedule of Selective Demolition Activities:** Indicate the following:
1. Detailed sequence of selective demolition and removal work, with starting and ending dates for each activity. Ensure Owner's on-site operations are uninterrupted.
 2. Interruption of utility services.
 3. Coordination for shutoff, capping, and continuation of utility services.
 4. Locations of temporary partitions and means of egress.
 5. Coordination of Owner's continuing occupancy of portions of existing building and of Owner's partial occupancy of completed Work.
- E. **Inventory:** After selective demolition is complete, submit a list of items that have been removed and salvaged.
- F. **Pre-demolition Photographs or Videotape:** Show existing conditions of adjoining construction and site improvements, including finish surfaces, which might be misconstrued as damage caused by selective demolition operations. Submit before Work begins.
- G. **Landfill Records:** Indicate receipt and acceptance of hazardous wastes by a landfill facility licensed to accept hazardous wastes.

1.6 QUALITY ASSURANCE

- A. **Demolition Firm Qualifications:** An experienced firm that has specialized in demolition work similar in material and extent to that indicated for this Project.

- B. **Regulatory Requirements:** Comply with governing EPA notification regulations before beginning selective demolition. Comply with hauling and disposal regulations of authorities having jurisdiction.
- C. **Standards:** Comply with ANSI A10.6 and NFPA 241.
- D. **Pre-demolition Conference:** Conduct conference at Project site to comply with requirements in Division 1 Section "Project Management and Coordination." Review methods and procedures related to selective demolition including, but not limited to, the following:
 - 1. Inspect and discuss condition of construction to be selectively demolished.
 - 2. Review structural load limitations of existing structure.
 - 3. Review and finalize selective demolition schedule and verify availability of materials, demolition personnel, equipment, and facilities needed to make progress and avoid delays.
 - 4. Review requirements of work performed by other trades that rely on substrates exposed by selective demolition operations.

1.7 PROJECT CONDITIONS

- A. **Owner will occupy portions of building** immediately adjacent to selective demolition area. Conduct selective demolition so Owner's operations will not be disrupted. Provide not less than 72 hours' notice to Owner of activities that will affect Owner's operations.
- B. **Maintain access to existing walkways**, corridors, and other adjacent occupied or used facilities.
 - 1. Do not close or obstruct walkways, corridors, or other occupied or used facilities without written permission from authorities having jurisdiction.
- C. **Owner assumes no responsibility for condition of areas** to be selectively demolished.
 - 1. Conditions existing at time of inspection for bidding purpose will be maintained by Owner as far as practical.
- D. **Hazardous Materials:** It is not expected that hazardous materials will be encountered in the Work.
 - 1. Hazardous materials will be removed by Owner before start of the Work.
 - 2. If materials suspected of containing hazardous materials are encountered, do not disturb; immediately notify Architect and Owner. Hazardous materials will be removed by Owner under a separate contract.
- E. **Storage or sale of removed items** or materials on-site will not be permitted.
- F. **Utility Service:** Maintain existing utilities indicated to remain in service and protect them against damage during selective demolition operations.
 - 1. Maintain fire-protection facilities in service during selective demolition operations.

PART 2 - PRODUCTS

2.1 REPAIR MATERIALS

- A. **Use repair materials** identical to existing materials.
 - 1. If identical materials are unavailable or cannot be used for exposed surfaces, use materials that visually match existing adjacent surfaces to the fullest extent possible.
 - 2. Use materials whose installed performance equals or surpasses that of existing materials.
- B. **Comply with material and installation requirements** specified in individual Specification Sections.

PART 3 - EXECUTION

3.1 EXAMINATION

- A. **Verify** that utilities have been disconnected and capped.
- B. **Survey existing conditions** and correlate with requirements indicated to determine extent of selective demolition required.
- C. **Inventory and record** the condition of items to be removed and reinstalled and items to be removed and salvaged.
- D. **When unanticipated mechanical, electrical, or structural elements** that conflict with intended function or design are encountered, investigate and measure the nature and extent of conflict. Promptly submit a written report to Architect.
- E. **Engage a professional engineer** to survey condition of building to determine whether removing any element might result in structural deficiency or unplanned collapse of any portion of structure or adjacent structures during selective demolition operations.
- F. **Perform surveys** as the Work progresses to detect hazards resulting from selective demolition activities.

3.2 UTILITY SERVICES

- A. **Existing Utilities:** Maintain services indicated to remain and protect them against damage during selective demolition operations.
- B. **Utility Interruption:** Do not interrupt existing utilities serving occupied or operating facilities unless authorized in writing by Owner and authorities having jurisdiction. Provide temporary services during interruptions to existing utilities, as acceptable to Owner and to authorities having jurisdiction.
- C. **Provide at least 72 hours'** notice to Owner if shutdown of service is required during changeover.
- D. **Utility Requirements:** Locate, identify, disconnect, and seal or cap off indicated utilities serving areas to be selectively demolished.

- E. **Owner will arrange to shut off indicated utilities** when requested by Contractor.
- F. **If utility services are required to be removed**, relocated, or abandoned, before proceeding with selective demolition provide temporary utilities that bypass area of selective demolition and that maintain continuity of service to other parts of building.
- G. **Cut off pipe or conduit in walls** or partitions to be removed. Cap, valve, or plug and seal remaining portion of pipe or conduit after bypassing.
- H. **Utility Requirements:** Refer to Mechanical and Electrical Sections for shutting off, disconnecting, removing, and sealing or capping utilities. Do not start selective demolition work until utility disconnecting and sealing have been completed and verified in writing.

3.3 PREPARATION

- A. **Dangerous Materials:** Drain, purge, or otherwise remove, collect, and dispose of chemicals, gases, explosives, acids, flammables, or other dangerous materials before proceeding with selective demolition operations.
- B. **Site Access and Temporary Controls:** Conduct selective demolition and debris-removal operations to ensure minimum interference with roads, streets, walks, walkways, and other adjacent occupied and used facilities.
 - 1. Do not close or obstruct streets, walks, walkways, or other adjacent occupied or used facilities without permission from Owner and authorities having jurisdiction. Provide alternate routes around closed or obstructed traffic ways if required by governing regulations.
 - 2. Erect temporary protection, such as walks, fences, railings, canopies, and covered passageways, where required by authorities having jurisdiction.
 - 3. Protect existing site improvements, appurtenances, and landscaping to remain.
- C. **Temporary Facilities:** Provide temporary barricades and other protection required to prevent injury to people and damage to adjacent buildings and facilities to remain.
 - 1. Provide protection to ensure safe passage of people around selective demolition area and to and from occupied portions of building.
 - 2. Protect walls, ceilings, floors, and other existing finish work that are to remain or that are exposed during selective demolition operations.
 - 3. Cover and protect furniture, furnishings, and equipment that have not been removed.
- D. **Temporary Enclosures:** Provide temporary enclosures for protection of existing building and construction, in progress and completed, from exposure, foul weather, other construction operations, and similar activities. Provide temporary weathertight enclosure for building exterior.
 - 1. Where heating or cooling is needed and permanent enclosure is not complete, provide insulated temporary enclosures. Coordinate enclosure with ventilating and material drying or curing requirements to avoid dangerous conditions and effects.
- E. **Temporary Partitions:** Erect and maintain dustproof partitions and temporary enclosures to limit dust and dirt migration and to separate areas from fumes and noise.
- F. **Temporary Shoring:** Provide and maintain shoring, bracing, or structural support to preserve stability and prevent movement, settlement, or collapse of construction to remain, and to prevent unexpected or uncontrolled movement or collapse of construction being demolished.

1. Strengthen or add new supports when required during progress of selective demolition.

3.4 POLLUTION CONTROLS

- A. **Temporary ventilation:** Provide temporary ventilation as follows:
 1. Vacuum old carpets prior to removal using a certified Carpet and Rug Institute (CRI) Green Label vacuum cleaner. Vacuum floor immediately after old carpet is removed.
- B. **Dust Control:** Use water mist, temporary enclosures, and other suitable methods to limit spread of dust and dirt. Comply with governing environmental-protection regulations.
 1. Do not use water when it may damage existing construction or create hazardous or objectionable conditions, such as ice, flooding, and pollution.
 2. Wet mop floors to eliminate trackable dirt and wipe down walls and doors of demolition enclosure. Vacuum carpeted areas.
- C. **Disposal:** Remove and transport debris in a manner that will prevent spillage on adjacent surfaces and areas.
 1. Remove debris from elevated portions of building by chute, hoist, or other device that will convey debris to grade level in a controlled descent.
- D. **Cleaning:** Clean adjacent structures and improvements of dust, dirt, and debris caused by selective demolition operations. Return adjacent areas to condition existing before selective demolition operations began.

3.5 SELECTIVE DEMOLITION

- A. **General:** Demolish and remove existing construction only to the extent required by new construction and as indicated. Use methods required to complete the Work within limitations of governing regulations and as follows:
 1. Proceed with selective demolition systematically, from higher to lower level. Complete selective demolition operations above each floor or tier before disturbing supporting members on the next lower level.
 2. Neatly cut openings and holes plumb, square, and true to dimensions required. Use cutting methods least likely to damage construction to remain or adjoining construction. Use hand tools or small power tools designed for sawing or grinding, not hammering and chopping, to minimize disturbance of adjacent surfaces. Temporarily cover openings to remain.
 3. Cut or drill from the exposed or finished side into concealed surfaces to avoid marring existing finished surfaces.
 4. Do not use cutting torches until work area is cleared of flammable materials. At concealed spaces, such as duct and pipe interiors, verify condition and contents of hidden space before starting flame-cutting operations. Maintain portable fire-suppression devices during flame-cutting operations.
 5. Maintain adequate ventilation when using cutting torches.
 6. Remove decayed, vermin-infested, or otherwise dangerous or unsuitable materials and promptly dispose of off-site.
 7. Remove structural framing members and lower to ground by method suitable to avoid free fall and to prevent ground impact or dust generation.
 8. Locate selective demolition equipment and remove debris and materials so as not to impose excessive loads on supporting walls, floors, or framing.
 9. Dispose of demolished items and materials promptly.
 10. Return elements of construction and surfaces that are to remain to condition existing before selective demolition operations began.

- B. **Existing Facilities:** Comply with Owner's requirements for using and protecting walkways, building entries, and other building facilities during selective demolition operations.
- C. **Removed and Salvaged Items:** Comply with the following:
1. Clean salvaged items.
 2. Pack or crate items after cleaning. Identify contents of containers.
 3. Store items in a secure area until delivery to Owner.
 4. Transport items to Owner's storage area designated by Owner.
 5. Protect items from damage during transport and storage.
- D. **Removed and Reinstalled Items:** Comply with the following:
1. Clean and repair items to functional condition adequate for intended reuse. Paint equipment to match new equipment.
 2. Pack or crate items after cleaning and repairing. Identify contents of containers.
 3. Protect items from damage during transport and storage.
 4. Reinstall items in locations indicated. Comply with installation requirements for new materials and equipment. Provide connections, supports, and miscellaneous materials necessary to make item functional for use indicated.
- E. **Existing Items to Remain:** Protect construction indicated to remain against damage and soiling during selective demolition. When permitted by Architect, items may be removed to a suitable, protected storage location during selective demolition and cleaned and reinstalled in their original locations after selective demolition operations are complete.
- F. **Concrete:** Neatly core drill openings in existing floor - verify locations of services in suspended slab and below before any cutting.

3.6 PATCHING AND REPAIRS

- A. **General:** Promptly repair damage to adjacent construction caused by selective demolition operations.
- B. **Repairs:** Where repairs to existing surfaces are required, patch to produce surfaces suitable for new materials.
1. Completely fill holes and depressions in existing masonry walls that are to remain with an approved masonry patching material applied according to manufacturer's written recommendations.
- C. **Finishes:** Restore exposed finishes of patched areas and extend restoration into adjoining construction in a manner that eliminates evidence of patching and refinishing.
- D. **Floors and Walls:** Where walls or partitions that are demolished extend one finished area into another, patch and repair floor and wall surfaces in the new space. Provide an even surface of uniform finish color, texture, and appearance. Remove existing floor and wall coverings and replace with new materials, as noted on Drawings, to achieve uniform color and appearance.
1. Patch with durable seams that are as invisible as possible. Provide materials and comply with installation requirements specified in other Sections of these Specifications.
 2. Skim coat entire wall surface with drywall compound to provide smooth, unblemished substrate for new paint finish.
 3. Where patching occurs in a painted surface, apply primer and intermediate paint coats over patch and apply final paint coat over entire unbroken surface containing patch. Provide additional coats until patch blends with adjacent

- surfaces.
- 4. Test and inspect patched areas after completion to demonstrate integrity of installation.

- E. **Ceilings:** Patch, repair, or rehang existing ceilings as necessary to provide an even-plane surface of uniform appearance. Replace damaged ceiling panels with new panels, matching existing.

3.7 DISPOSAL OF DEMOLISHED MATERIALS

- A. **General:** Promptly dispose of demolished materials. Do not allow demolished materials to accumulate on-site.
- B. **Burning:** Do not burn demolished materials.
- C. **Disposal:** Transport demolished materials off Owner's property and legally dispose of them.

END OF SECTION

DIVISION 03 – CONCRETE

Not Used

THIS PAGE LEFT BLANK INTENTIONALLY

DIVISION 04 – MASONRY

Not Used

THIS PAGE LEFT BLANK INTENTIONALLY

DIVISION 05 – METALS

Section 05 5000

Metal Fabrication

THIS PAGE LEFT BLANK INTENTIONALLY

SECTION 05 5000

METAL FABRICATIONS

PART 1 - GENERAL

1.1 RELATED DOCUMENTS

- A. Drawings and general provisions of the Contract, including General and Supplementary Conditions and Division 1 Specification Sections, apply to this Section.

1.2 SUMMARY

- A. This **Section includes** the following:
 - 1. Steel framing and supports for countertops.
 - 2. Steel framing and supports for applications where framing and supports are not specified in other Sections.
- B. **Related Sections** include the following:
 - 1. Section 06 1053 "**Miscellaneous Rough Carpentry**" for metal framing anchors and other rough hardware.

1.3 SUBMITTALS

- A. **Product Data:** For the following:
 - 1. Paint products.
 - 2. Grout.
- B. **Shop Drawings General:** Detail fabrication and erection of each metal fabrication indicated. Include plans, elevations, sections, and details of metal fabrications and their connections. Show anchorage and accessory items.
 - 1. Provide templates for anchors and bolts specified for installation under other Sections.
- C. **Welding Certificates:** Copies of certificates for welding procedures and personnel.
- D. **Qualification Data:** For firms and persons specified in "Quality Assurance" Article to demonstrate their capabilities and experience. Include lists of completed projects with project names and addresses, names and addresses of architects and owners, and other information specified.

1.4 QUALITY ASSURANCE

- A. **Fabricator Qualifications:** A firm experienced in producing metal fabrications similar to those indicated for this Project and with a record of successful in-service performance, as well as sufficient production capacity to produce required units.
- B. **Welding:** Qualify procedures and personnel according to the following:
 - 1. AWS D1.1, "Structural Welding Code--Steel."
 - 2. AWS D1.2, "Structural Welding Code--Aluminum."
 - 3. AWS D1.3, "Structural Welding Code--Sheet Steel."
 - 4. Certify that each welder has satisfactorily passed AWS qualification tests for welding processes involved and, if pertinent, has undergone recertification.

- C. **Architectural Exposed Steel:** All exposed steel members shall be detailed, fabricated and erected as Architecturally Exposed Structural Steel (AESS) as defined in the AISC Code of Standard Practice.

1.5 PROJECT CONDITIONS

- A. **Field Measurements General:** Where metal fabrications are indicated to fit walls and other construction, verify dimensions by field measurements before fabrication and indicate measurements on Shop Drawings. Coordinate fabrication schedule with construction progress to avoid delaying the Work.
1. **Established Dimensions:** Where field measurements cannot be made without delaying the Work, establish dimensions and proceed with fabricating metal fabrications without field measurements. Coordinate construction to ensure that actual dimensions correspond to established dimensions. Allow for trimming and fitting.

1.6 COORDINATION

- A. **Coordinate installation of anchorages for metal fabrications.** Furnish setting drawings, templates, and directions for installing anchorages, including sleeves, concrete inserts, anchor bolts, and items with integral anchors, that are to be embedded in concrete or masonry. Deliver such items to Project site in time for installation.

PART 2 - PRODUCTS

2.1 METALS, GENERAL

- A. **Metal Surfaces, General:** For metal fabrications exposed to view in the completed Work, provide materials with smooth, flat surfaces without blemishes. Do not use materials with exposed pitting, seam marks, roller marks, rolled trade names, or roughness. Do not use steel sheet with variations in flatness exceeding those permitted by referenced standards for stretcher-leveled sheet.

2.2 FERROUS METALS

- A. **Steel Plates, Shapes, and Bars:** ASTM A 36/A 36M and ASTM 570 Grade 50 where indicated.
- B. **Uncoated Hot-Rolled Steel Sheet:** Commercial quality, complying with ASTM A 569/A569M or structural quality, complying with ASTM A 570/A 570M, Grade 30, unless another grade is required by design loads.
- C. **Brackets, Flanges, and Anchors:** Cast or formed metal of same type of material and finish as supported rails, unless otherwise indicated.
- D. **Slotted Channel Framing:** Cold-formed metal channels with flange edges returned toward web and with 9/16-inch- wide slotted holes in webs at 2 inches o.c.
1. Width of Channels: 1-5/8 inches.
 2. Depth of Channels: 1-5/8 inches.
 3. Metal and Thickness: Uncoated steel complying with ASTM A 570, Grade 33; 14 gauge (1.7-mm) minimum thickness.
 4. Finish: Rust-inhibitive, baked-on, acrylic enamel.
- E. **Welding Rods and Bare Electrodes:** Select according to AWS specifications for metal alloy welded.

2.3 ALUMINUM

- A. **Aluminum Extrusions:** ASTM B 221 (ASTM B 221M), alloy 6063-T6.
- B. **Glazing Channels:** Provide aluminum architectural shapes and extrusions, ASTM alloy 6063-T52, for glazing channels and pockets.

2.4 PAINT

- A. **Shop Primer for Ferrous Metal:** Fast-curing, lead- and chromate-free, universal modified-alkyd primer complying with performance requirements in FS TT-P-664; selected for good resistance to normal atmospheric corrosion, compatibility with finish paint systems indicated, and capability to provide a sound foundation for field-applied topcoats despite prolonged exposure.
 - 1. Refer to Section 09 9100 - Painting for specific primer required on identified steel items.
- B. **Bituminous Paint:** Cold-applied asphalt mastic complying with SSPC-Paint 12, except containing no asbestos fibers, or cold-applied asphalt emulsion complying with ASTM D 1187.

2.5 FASTENERS

- A. **General:** Provide Type 304 or 316 stainless-steel fasteners for exterior use and zinc-plated fasteners with coating complying with ASTM B 633, Class Fe/Zn 5, where built into exterior walls. Select fasteners for type, grade, and class required.
- B. **Bolts and Nuts:** Regular hexagon-head bolts, ASTM A 307, Grade A; with hex nuts, ASTM A 563; and, where indicated, flat washers.
- C. **Anchor Bolts:** ASTM F 1554, Grade 36.
- D. **Machine Screws:** ASME B18.6.3.
- E. **Lag Bolts:** ASME B18.2.1.
- F. **Wood Screws:** Flat head, carbon steel, ASME B18.6.1.
- G. **Plain Washers:** Round, carbon steel, ASME B18.22.1.
- H. **Lock Washers:** Helical, spring type, carbon steel, ASME B18.21.1.
- I. **Expansion Anchors:** Anchor bolt and sleeve assembly of material indicated below with capability to sustain, without failure, a load equal to six times the load imposed when installed in unit masonry and equal to four times the load imposed when installed in concrete, as determined by testing per ASTM E 488, conducted by a qualified independent testing agency.
 - 1. Material: Carbon-steel components zinc-plated to comply with ASTM B 633, Class Fe/Zn 5.
- J. **Toggle Bolts:** FS FF-B-588, tumble-wing type, class and style as needed.

2.6 GROUT

- A. **Nonshrink, Nonmetallic Grout:** Factory-packaged, nonstaining, noncorrosive, nongaseous grout complying with ASTM C 1107. Provide grout specifically recommended by manufacturer for interior and exterior applications.

2.7 FABRICATION, GENERAL

- A. **Shop Assembly:** Preassemble items in shop to greatest extent possible to minimize field splicing and assembly. Disassemble units only as necessary for shipping and handling limitations. Use connections that maintain structural value of joined pieces. Clearly mark units for reassembly and coordinated installation.
- B. **Shear and punch** metals cleanly and accurately. Remove burrs.
- C. **Ease exposed edges** to a radius of approximately 1/32 inch, unless otherwise indicated. Form bent-metal corners to smallest radius possible without causing grain separation or otherwise impairing work.
- D. **Weld corners** and seams continuously to comply with the following:
 - 1. Use materials and methods that minimize distortion and develop strength and corrosion resistance of base metals.
 - 2. Obtain fusion without undercut or overlap.
 - 3. Remove welding flux immediately.
 - 4. At exposed connections, finish exposed welds and surfaces smooth and blended so no roughness shows after finishing and contour of welded surface matches that of adjacent surface.
- E. **Provide for anchorage** of type indicated; coordinate with supporting structure. Fabricate and space anchoring devices to secure metal fabrications rigidly in place and to support indicated loads.
- F. **Cut, reinforce, drill, and tap metal fabrications** as indicated to receive finish hardware, screws, and similar items.
- G. **Fabricate joints** that will be exposed to weather in a manner to exclude water, or provide weep holes where water may accumulate.
- H. **Allow for thermal movement** resulting from the following maximum change (range) in ambient and surface temperatures by preventing buckling, opening up of joints, overstressing of components, failure of connections, and other detrimental effects. Base engineering calculation on surface temperatures of materials due to both solar heat gain and nighttime-sky heat loss.
 - 1. **Temperature Change** (Range): 120 degrees F, ambient; 180 degrees F, material surfaces.
- I. **Form exposed work true to line** and level with accurate angles and surfaces and straight sharp edges.
- J. **Remove sharp or rough areas** on exposed traffic surfaces.
- K. **Form exposed connections with hairline joints**, flush and smooth, using concealed fasteners where possible. Use exposed fasteners of type indicated or, if not indicated, Phillips flat-head (countersunk) screws or bolts. Locate joints where least conspicuous.

2.8 MISCELLANEOUS FRAMING AND SUPPORTS

- A. **General:** Provide steel framing and supports that are not a part of structural-steel framework as necessary to complete the Work.
- B. **Fabricate units** from structural-steel shapes, plates, and bars of welded construction, unless otherwise indicated. Fabricate to sizes, shapes, and profiles indicated and as necessary to receive adjacent construction retained by framing and supports. Cut, drill, and tap units to receive hardware, hangers, and similar items.
 - 1. Fabricate units from slotted channel framing where required for deflection.
 - 2. Where units are indicated to be cast into concrete or built into masonry, equip with integrally welded steel strap anchors 1-1/4 inches wide by 1/4 inch thick by 8 inches long at 24 inches o.c., unless otherwise indicated.
 - 3. Furnish inserts if units must be installed after concrete is placed.
- C. **Framing at New Exhaust Fans:** Provide angle framing to accommodate opening and to support new curbs and frames. Weld to existing structure; coordinate opening with exhaust dimensions and weight.

2.9 FINISHES, GENERAL

- A. **Comply with NAAMM's** "Metal Finishes Manual for Architectural and Metal Products" for recommendations for applying and designating finishes.
- B. Finish metal fabrications after assembly.

2.10 STEEL AND IRON FINISHES

- A. **Preparation for Shop Priming:** Prepare uncoated ferrous-metal surfaces to comply with minimum requirements indicated below for SSPC surface-preparation specifications and environmental exposure conditions of installed metal fabrications:
 - 1. Interiors (SSPC Zone 1A): SSPC-SP 3, "Power Tool Cleaning."
- B. **Application:** Apply shop primer to uncoated surfaces of metal fabrications, except those with galvanized finishes and those to be embedded in concrete, sprayed-on fireproofing, or masonry, unless otherwise indicated. Comply with SSPC-PA 1, "Paint Application Specification No. 1," for shop painting.
 - 1. Stripe paint corners, crevices, bolts, welds, and sharp edges.

PART 3 - EXECUTION

3.1 INSTALLATION, GENERAL

- A. **Fastening to In-Place Construction:** Provide anchorage devices and fasteners where necessary for securing metal fabrications to in-place construction. Include threaded fasteners for concrete and masonry inserts, toggle bolts, through-bolts, lag bolts, wood screws, and other connectors.
- B. **Cutting, Fitting, and Placement:** Perform cutting, drilling, and fitting required for installing metal fabrications. Set metal fabrications accurately in location, alignment, and elevation; with edges and surfaces level, plumb, true, and free of rack; and measured from established lines and levels.
- C. **Provide temporary bracing** or anchors in formwork for items that are to be built into concrete, masonry, or similar construction.

- D. **Fit exposed connections accurately together to form hairline joints.** Weld connections that are not to be left as exposed joints but cannot be shop welded because of shipping size limitations. Do not weld, cut, or abrade surfaces of exterior units that have been hot-dip galvanized after fabrication and are for bolted or screwed field connections.
- E. **Field Welding:** Comply with the following requirements:
1. Use materials and methods that minimize distortion and develop strength and corrosion resistance of base metals.
 2. Obtain fusion without undercut or overlap.
 3. Remove welding flux immediately.
 4. At exposed connections, finish exposed welds and surfaces smooth and blended so no roughness shows after finishing and contour of welded surface matches that of adjacent surface.
- F. **Corrosion Protection:** Coat concealed surfaces of aluminum that will come into contact with grout, concrete, masonry, wood, or dissimilar metals with a heavy coat of bituminous paint.

3.2 INSTALLING MISCELLANEOUS FRAMING AND SUPPORTS

- A. **General:** Install framing and supports to comply with requirements of items being supported, including manufacturers' written instructions and requirements indicated on Shop Drawings, if any.
- B. **Support steel girders on solid grouted masonry,** concrete, or steel pipe columns. Secure girders with anchor bolts embedded in grouted masonry or concrete or with bolts through top plates of pipe columns.
1. Where grout space under bearing plates is indicated at girders supported on concrete or masonry, install as specified above for setting and grouting bearing and leveling plates.

3.3 ADJUSTING AND CLEANING

- A. **Touchup Painting:** Immediately after erection, clean field welds, bolted connections, and abraded areas of shop paint, and paint exposed areas with the same material as used for shop painting to comply with SSPC-PA 1 for touching up shop-painted surfaces.
1. Apply by brush or spray to provide a minimum 2.0-mil dry film thickness.

END OF SECTION

DIVISION 06 – WOOD, PLASTICS, AND COMPOSITES

Section 06 1053
Section 06 2000
Section 06 4023

Miscellaneous Rough Carpentry
Finish Carpentry
Interior Architectural Woodwork

THIS PAGE LEFT BLANK INTENTIONALLY

SECTION 06 1053

MISCELLANEOUS ROUGH CARPENTRY

PART 1 - GENERAL

1.1 RELATED DOCUMENTS

- A. Drawings and general provisions of the Contract, including General and Supplementary Conditions and Division 1 Specification Sections, apply to this Section.

1.2 SUMMARY

- A. This Section includes the following:
 - 1. Rooftop equipment bases and support curbs.
 - 2. Wood furring, grounds, nailers, and blocking.
 - 3. Plywood backing panels.
 - 4. Framing with dimension lumber.
- B. **Related Sections:**
 - 1. Section 09 2216 "**Non-Structural Metal Framing**" for metal strap blocking.

1.3 SUBMITTALS

- A. **Wood treatment data as follows**, including chemical treatment manufacturer's instructions for handling, storing, installing, and finishing treated materials:
 - 1. For each type of preservative-treated wood product, include certification by treating plant stating type of preservative solution and pressure process used, net amount of preservative retained, and compliance with applicable standards.
 - 2. For waterborne-treated products, include statement that moisture content of treated materials was reduced to levels indicated before shipment to Project site.
 - 3. Include data for fire-retardant treatment from chemical treatment manufacturer and certification by treating plant that treated materials comply with requirements. Include physical properties of treated materials based on testing by a qualified independent testing agency.
- B. **Material test reports** from a qualified independent testing agency indicating and interpreting test results relative to compliance of fire-retardant-treated wood products with performance requirements indicated.
- C. **Warranty of chemical treatment** manufacturer for each type of treatment.
- D. **Informational Submittals**
 - A. **Material Certificates:** For dimension lumber specified to comply with minimum allowable unit stresses. Indicate species and grade selected for each use and design values approved by the ALSC Board of Review.
 - B. **Evaluation Reports:** For the following, from ICC-ES:
 - 1. Wood-preservative-treated wood.
 - 2. Fire-retardant-treated wood.
 - 3. Expansion and post-installed anchors.
 - 4. Metal framing anchors.

1.4 DELIVERY, STORAGE, AND HANDLING

- A. **Keep materials under cover and dry.** Protect from weather and contact with damp or wet surfaces. Stack lumber, plywood, and other panels. Provide for air circulation via spacers within and around stacks and under temporary coverings.
1. For lumber and plywood pressure treated with waterborne chemicals, place spacers between each bundle to provide air circulation.

1.5 QUALITY ASSURANCE

- A. **Adhesives and Sealants:** For products applied on site and located inside the weatherproofing system, comply with the VOC content limits of the State of Utah.
- B. **Paints and Coatings:** For products applied on site and located inside the weatherproofing system, comply with the VOC content limits of the State of Utah.
- C. **Composite wood, agrifiber products, and adhesives** shall not contain urea-formaldehyde resin.

PART 2 - PRODUCTS

2.1 LUMBER, GENERAL

- A. **Lumber Standards:** Comply with DOC PS 20, "American Softwood Lumber Standard," and with applicable grading rules of inspection agencies certified by American Lumber Standards Committee's (ALSC) Board of Review. Provide lumber graded by an agency certified by the ALSC Board of Review to inspect and grade lumber under the rules indicated.
1. Factory mark each piece of lumber with grade stamp of grading agency.
 2. For exposed lumber indicated to receive a stained or natural finish, mark grade stamp on end or back of each piece or omit grade stamp and provide certificates of grade compliance issued by grading agency.
 3. Where nominal sizes are indicated, provide actual sizes required by DOC PS 20 for moisture content specified. Where actual sizes are indicated, they are minimum dressed sizes for dry lumber.
 4. Provide dressed lumber, S4S, unless otherwise indicated.
- B. **Inspection Agencies:** Inspection agencies, and the abbreviations used to reference them, include the following:
1. NELMA - Northeastern Lumber Manufacturers Association.
 2. RIS - Redwood Inspection Service.
 3. SPIB - Southern Pine Inspection Bureau.
 4. WCLIB - West Coast Lumber Inspection Bureau.
 5. WWPA - Western Wood Products Association.
- C. **Grade Stamps:** Provide lumber with each piece factory marked with grade stamp of inspection agency evidencing compliance with grading rule requirements and identifying grading agency, grade, species, moisture content at time of surfacing, and mill.
1. For exposed lumber, furnish pieces with grade stamps applied to ends or back of each piece.
- D. **Nominal Sizes:** Where nominal sizes are indicated, provide actual sizes required by DOC PS 20 for moisture content specified. Where actual sizes are indicated, they are minimum dressed sizes for dry lumber.
1. Provide dressed lumber, S4S, unless otherwise indicated.
 2. Provide dry lumber with 19 percent maximum moisture content at time of dressing for 2-inch nominal thickness or less, unless otherwise indicated.

2.2 WOOD-PRESERVATIVE-TREATED MATERIALS

- A. **General:** Where lumber or plywood is indicated as preservative treated or is specified to be treated, comply with applicable requirements of AWPA C2 (lumber) and AWPA C9 (plywood). Mark each treated item with the Quality Mark Requirements of an inspection agency approved by ALSC's Board of Review.
1. Do not use chemicals containing chromium or arsenic.
 2. For exposed items indicated to receive stained finish, use chemical formulations that do not bleed through, contain colorants, or otherwise adversely affect finishes.
- B. **Pressure treat aboveground items** with waterborne preservatives to a minimum retention of 0.25 lb/cu. ft. After treatment, kiln-dry lumber and plywood to a maximum moisture content of 19 and 15 percent, respectively. Treat indicated items and the following:
1. Wood cants, nailers, curbs, equipment support bases, blocking, stripping, and similar members in connection with roofing, flashing, vapor barriers, and waterproofing.
 2. Wood sills, sleepers, blocking, furring, stripping, and similar concealed members in contact with masonry or concrete.
 3. Wood framing and furring attached directly to the interior of below-grade exterior concrete walls.
 4. Wood floor plates that are installed over concrete slabs-on-grade
- C. **Pressure treat wood members in contact with ground** or freshwater with waterborne preservatives to a minimum retention of 0.40 lb/cu. ft.

2.3 FIRE-RETARDANT TREATMENT BY PRESSURE PROCESS

- A. **General:** Where fire-retardant-treated wood is indicated, pressure impregnate lumber and plywood with fire-retardant chemicals to comply with AWPA C20 and C27, respectively, for treatment type indicated; identify "fire-retardant-treated wood" with appropriate classification marking of Underwriters Laboratories, Inc., U.S. Testing, Timber Products Inspection, Inc. or other testing and inspecting agency acceptable to authorities having jurisdiction.
1. Current Evaluation/Research Reports: Provide fire-retardant- treated wood for which a current model code evaluation/research report exists that is acceptable to authorities having jurisdiction and that evidences compliance of fire-retardant-treated wood for application indicated.
- B. **Interior Type A:** For interior locations use fire-retardant chemical formulation that produces treated lumber and plywood with the following properties under conditions present after installation:
1. No reduction takes place in bending strength, stiffness, and fastener holding capacities below values published by manufacturer of chemical formulation that are based on tests by a qualified independent testing laboratory of treated wood products identical to those indicated for this Project under elevated temperature and humidity conditions simulating installed conditions.
 2. No other form of degradation occurs due to acid hydrolysis or other causes related to manufacture and treatment.
 3. No corrosion of metal fasteners results from their contact with treated wood.
- C. **Inspection:** Inspect each piece of treated lumber or plywood after drying and discard damaged or defective pieces.

- D. **Products:** Subject to compliance with requirements, provide one of the following:
1. Interior Type A Fire-Retardant-Treated Wood:
 - a. "Dricon" Hickson Corporation.
 - b. "Pyro-Guard" Hoover Treated Wood Products.
 - c. "Flameproof LHC-HTT" Osmose Wood Preserving Co, Inc.

2.4 DIMENSION LUMBER

- A. **General:** Provide dimension lumber of grades indicated according to the ALSC National Grading Rule (NGR) provisions of the inspection agency indicated.
- B. **Maximum Moisture Content:** 19 percent.
- C. **Framing:** As indicated on the Structural Drawings. Where not indicated: No. 2 grade and any of the following species:
1. Hem-fir (north); NLGA.
 2. Southern pine; SPIB.
 3. Douglas fir-larch; WCLIB or WWPA.
 4. Mixed southern pine; SPIB.
 5. Spruce-pine-fir; NLGA.
 6. Douglas fir-south; WWPA.
 7. Hem-fir; WCLIB or WWPA.
 8. Douglas fir-larch (north); NLGA.
 9. Spruce-pine-fir (south); NeLMA, WCLIB, or WWPA.

2.5 MISCELLANEOUS LUMBER

- A. **General:** Provide lumber for support or attachment of other construction, including rooftop equipment curbs and support bases, cant strips, bucks, nailers, blocking, furring, grounds, stripping, and similar members.
- B. **Fabricate miscellaneous lumber** from dimension lumber of sizes indicated and into shapes shown.
- C. **Moisture Content:** 19 percent maximum for lumber items are not specified to receive wood preservative treatment.
- D. **Grade:** For dimension lumber sizes, provide Construction or No. 2 grade lumber of any species.

2.6 PLYWOOD BACKING PANELS

- A. **For mounting electrical or telephone** equipment, provide fire-retardant-treated plywood panels with grade, C-D Plugged Exposure 1, in thickness indicated or, if not otherwise indicated, not less than 15/32 inch thick.

2.7 FASTENERS

- A. **General:** Provide fasteners of size and type indicated that comply with requirements specified in this Article for material and manufacture.
1. Where miscellaneous carpentry is exposed to weather, in ground contact, or in area of high relative humidity, provide fasteners with a hot-dip zinc coating per ASTM A 153 or of Type 304 stainless steel.

- B. **Nails, Wire, Brads, and Staples:** ASTM F 1667.
- C. **Power-Driven Fasteners:** CABO NER-272.
- D. **Bolts:** Steel bolts complying with ASTM A 307, Grade A; with ASTM A 563 hex nuts and, where indicated, flat washers.
- E. **Wood Screws:** ASME B18.6.1.
- F. **Lag Bolts:** ASME B18.2.1.
- G. **Post-installed Anchors:** Anchors with current ICC or IAPMO testing, tested to perform in cracked concrete under seismic loading.
 - 1. **Material:** Carbon-steel components, zinc plated to comply with ASTM B 633, Class Fe/Zn 5.

2.8 METAL FRAMING ANCHORS

- A. **General:** Provide galvanized steel framing anchors of structural capacity, type, and size indicated and as follows:
 - 1. **Research or Evaluation Reports:** Provide products for which model code research or evaluation reports exist that are acceptable to authorities having jurisdiction and that evidence compliance of metal framing anchors for application indicated with building code in effect for Project.
 - 2. **Allowable Design Loads:** Provide products with allowable design loads, as published by manufacturer, which meet or exceed those indicated. Manufacturer's published values shall be determined from empirical data or by rational engineering analysis, and demonstrated by comprehensive testing performed by a qualified independent testing agency.
- B. **Galvanized Steel Sheet:** Hot-dip, zinc-coated steel sheet complying with ASTM A 653, G60 coating designation; structural, commercial, or lock-forming quality, as standard with manufacturer for type of anchor indicated.

PART 3 - EXECUTION

3.1 INSTALLATION, GENERAL

- A. **Discard units of material with defects** that impair quality of carpentry and that are too small to use with minimum number of joints or optimum joint arrangement.
- B. **Set carpentry to required levels** and lines, with members plumb, true to line, cut, and fitted.
- C. **Fit carpentry to other construction;** scribe and cope as required for accurate fit. Correlate location of furring, nailers, blocking, grounds, and similar supports to allow attachment of other construction.
- D. **Apply field treatment** complying with AWWPA M4 to cut surfaces of preservative-treated lumber and plywood.
- E. **Securely attach carpentry work** as indicated and according to applicable codes and recognized standards.
- F. **Countersink nail heads** on exposed carpentry work and fill holes with wood filler.

- G. **Use fasteners of appropriate type and length.** Predrill members when necessary to avoid splitting wood.
- H. **Framing Standard:** Comply with AF&PA's "Details for Conventional Wood Frame Construction," unless otherwise indicated.
- I. **Metal Framing Anchors:** Install metal framing to comply with manufacturer's written instructions.
- J. **Do not splice structural members between supports,** unless otherwise indicated.
- K. **Provide blocking and framing as indicated and as required to support facing materials,** fixtures, specialty items, and trim.
 - 1. Provide metal clips for fastening gypsum board at corners and intersections where framing or blocking does not provide a surface for fastening edges of panels. Space clips not more than 16 inches o.c.
- L. **Provide fire blocking** in furred spaces, stud spaces, and other concealed cavities as indicated and as follows:
 - 1. Fire block furred spaces of walls, at each floor level, at ceiling, and at not more than 96 inches o.c. with solid wood blocking or noncombustible materials accurately fitted to close furred spaces.
 - 2. Fire block concealed spaces of wood-framed walls and partitions at each floor level, at ceiling line of top story, and at not more than 96 inches o.c. Where fire blocking is not inherent in framing system used, provide closely fitted solid wood blocks of same width as framing members and 2-inch nominal- thickness.
 - 3. Fire block concealed spaces behind combustible cornices and exterior trim at not more than 20 feet o.c.
- M. **Sort and select lumber so that natural characteristics will not interfere with installation** or with fastening other materials to lumber. Do not use materials with defects that interfere with function of member or pieces that are too small to use with minimum number of joints or optimum joint arrangement.
- N. **Comply with AWWA M4** for applying field treatment to cut surfaces of preservative-treated lumber.
 - 1. Use inorganic boron for items that are continuously protected from liquid water.
 - 2. Use copper naphthenate for items not continuously protected from liquid water.
- O. **Securely attach rough carpentry work to substrate** by anchoring and fastening as indicated, complying with the following:
 - 1. Table 2304.9.1, "Fastening Schedule," in ICC's International Building Code.
- Q. **Use common wire nails, unless otherwise indicated.** Select fasteners of size that will not fully penetrate members where opposite side will be exposed to view or will receive finish materials. Make tight connections between members. Install fasteners without splitting wood; do not countersink nail heads, unless otherwise indicated.
 - 1. Comply with approved fastener patterns where applicable.

3.2 WOOD GROUNDS, NAILERS, BLOCKING, AND SLEEPERS

- A. **Install where shown** and where required for screeding or attaching other work. Cut and shape to required size. Coordinate locations with other work involved.
- B. **Attach to substrates** to support applied loading. Recess bolts and nuts flush with surfaces, unless otherwise indicated.

- C. **Where wood-preservative-treated lumber** is installed adjacent to metal decking, install continuous flexible flashing separator between wood and metal decking.

3.3 WOOD FURRING

- A. **Install plumb and level** with closure strips at edges and openings. Shim with wood as required for tolerance of finish work.

3.4 WALL AND PARTITION FRAMING INSTALLATION

- A. **General:** Provide single bottom plate and double top plates using members of 2-inch nominal thickness whose widths equal that of studs, except single top plate may be used for non-load-bearing partitions. Fasten plates to supporting construction, unless otherwise indicated.
 - 1. For interior partitions and walls, provide 2-by-4-inch nominal- size wood studs spaced 16 inches o.c., unless otherwise indicated.
 - 2. Provide continuous horizontal blocking at midheight of partitions more than 96 inches high, using members of 2-inch nominal thickness and of same width as wall or partitions.
- B. **Construct corners and intersections** with three or more studs.
- C. **Frame openings with multiple studs and headers.** Provide nailed header members of thickness equal to width of studs. Support headers on jamb studs.
 - 1. For non-load-bearing partitions, provide double-jamb studs and headers not less than 4-inch nominal depth for openings 48 inches and less in width, 6-inch nominal depth for openings 48 to 72 inches in width, 8-inch nominal depth for openings 72 to 120 inches in width, and not less than 10-inch nominal depth for openings 10 to 12 feet in width.
 - 2. For load-bearing walls, provide jamb studs as indicated. Provide headers of depth indicated.

END OF SECTION

THIS PAGE LEFT BLANK INTENTIONALLY

SECTION 06 2000
FINISH CARPENTRY

PART 1 - GENERAL

1.1 RELATED DOCUMENTS

- A. Drawings and general provisions of the Contract, including General and Supplementary Conditions and Division 1 Specification Sections, apply to this Section.

1.2 SUMMARY

- A. **This Section includes** the following:
1. Solid surfacing material for window sills.
 2. Miscellaneous wood trim.
- B. **Related Sections:** The following Sections contain requirements that relate to this Section:
1. Section 06 1053 "**Miscellaneous Rough Carpentry**" for furring, blocking, and other carpentry work not exposed to view.
 2. Section 06 4023 "**Interior Architectural Woodwork**" for general millwork
 3. Section 09 2216 "**Non-Structural Metal Framing**" for installation of sheet metal strips coordinated with spacing of finish plywood panel fasteners.

1.3 SUBMITTALS

- A. **Product Data:** Provide product data for each type of factory-fabricated product and process specified, including details of construction relative to materials, dimensions of individual components, profiles, textures, and colors.

1.4 QUALITY ASSURANCE

- A. **AWS Quality Standard:** Comply with applicable requirements of AWI/WI/AWMAC Architectural Woodwork Standards (AWS) - 2nd Edition, October 1, 2014, except as otherwise indicated.
- B. **Installer Qualifications:** Engage an experienced Installer who has completed finish carpentry similar in material, design, and extent to that indicated for this Project and with a record of successful in-service performance.

1.5 DELIVERY, STORAGE, AND HANDLING

- A. **Delivery and Storage:** Keep materials under cover and dry. Protect against exposure to weather and contact with damp or wet surfaces. Stack lumber, plywood, and other panels. Provide for air circulation within and around stacks and under temporary coverings.
- B. **Environmental Conditions:** Do not deliver interior finish carpentry until environmental conditions meet requirements specified for installation areas. If finish carpentry must be stored in other than installation areas, store only where environmental conditions meet requirements specified for installation areas.

1.6 PROJECT CONDITIONS

- A. **Environmental Limitations:** Do not deliver or install interior finish carpentry until building is enclosed and weatherproof, wet-work in space is completed and nominally dry, and HVAC system is operating and will maintain temperature and relative humidity at occupancy levels through the remainder of construction period.

PART 2 - PRODUCTS

2.1 MATERIALS, GENERAL

- A. **Lumber Standards:** Comply with DOC PS 20, "American Softwood Lumber Standard," for lumber and with applicable grading rules of inspection agencies certified by American Lumber Standards Committee Board of Review.
- B. **Inspection Agencies:** Inspection agencies, and the abbreviations used to reference them, include the following:
1. NHLA - National Hardwood Lumber Association.
 2. RIS - Redwood Inspection Service.
 3. SPIB - Southern Pine Inspection Bureau.
 4. WCLIB - West Coast Lumber Inspection Bureau.
 5. WWPA - Western Wood Products Association.
- C. **Grade Stamps:** Provide lumber with each piece factory marked with grade stamp of inspection agency evidencing compliance with grading rule requirements and identifying grading agency, grade, species, moisture content at time of surfacing, and mill.
1. For exposed lumber, furnish pieces with grade stamps applied to ends or back of each piece, or omit grade stamps entirely and provide certificates of grade compliance issued by inspection agency.

2.2 INTERIOR STANDING AND RUNNING TRIM

- A. **Softwood Trim:** Provide finished lumber and moldings complying with the following requirements including those of the grading agency listed with species:
1. Species: Poplar; NLGA, WCLIB, or WWPA.
 2. Grade: B & Better. Select or Supreme.
 3. Texture: Surfaced (smooth).
 4. Lumber for Transparent Finish (Stained or Clear): Solid lumber stock.
 5. Lumber for Painted Finish: Glued-up lumber or solid lumber stock.
- B. **Hardwood Trim:** Provide finished hardwood lumber and moldings complying with the following requirements:
1. Species: Clear, kiln-dried white maple.
 2. Texture: Surfaced (smooth).
 3. Lumber for Transparent Finish (Stained or Clear): Solid lumber stock.
 4. Lumber for Painted Finish: Glued-up lumber or solid lumber stock.

2.3 SOLID-SURFACING-MATERIAL FOR WINDOW SILLS

- A. **Solid-Surfacing Material:** Homogeneous solid sheets of filled plastic resin complying with material and performance requirements in ANSI Z124.3, for Type 5 or Type 6, without a pre-coated finish.
1. Acceptable Product: Subject to compliance with requirements of Contract Documents, provide the following:
 - a. HI-MACS; LG Hausys.

- B. **Properties:**
1. Quality Standard: Comply with AWS Section 11 requirements for countertops.
 2. Grade: Custom.
 3. Solid-Surfacing-Material Thickness: 1/2 inch.
 4. Colors, Patterns, and Finishes: Provide materials and products that result in colors of solid-surfacing material complying with the following requirements:
 1. Provide Architect's selections from manufacturer's full range of colors and finishes.
- C. **Fabricate window sills** and wall caps in one piece with shop-applied edges, unless otherwise indicated. Comply with solid-surfacing-material manufacturer's written recommendations for adhesives, sealers, fabrication, and finishing.
1. Fabricate window sills and wall caps with dropped edge to cover raw edge of gypsum board.

2.4 MISCELLANEOUS MATERIALS

- A. **Fasteners for Interior Finish Carpentry:** Nails, screws, and other anchoring devices of type, size, material, and finish required for application indicated to provide secure attachment, concealed where possible.
1. Where finish carpentry materials are exposed in areas of high humidity, provide fasteners and anchorages with hot-dip galvanized coating complying with ASTM A 153.
- B. **Glue:** Aliphatic- or phenolic-resin wood glue recommended by manufacturer for general carpentry use.

2.5 FABRICATION

- A. **Wood Moisture Content:** Comply with requirements of specified inspection agencies and manufacturer's recommendations for moisture content of finish carpentry on relative humidity conditions existing during time of fabrication and in installation areas.
- B. **Fabricate finish carpentry to dimensions,** profiles, and details indicated.
1. Back out or kerf backs of the following members, except members with ends exposed in finished work:
 - a. Interior standing and running trim.
 2. Ease edges of lumber less than 1 inch in nominal thickness to 1/16-inch radius.
 3. Ease edges of lumber 1 inch or more in nominal thickness to 1/8-inch radius.

PART 3 - EXECUTION

3.1 EXAMINATION

- A. **Examine substrates,** with Installer present, for compliance with requirements for installation tolerances and other conditions affecting installation and performance of finish carpentry. Do not proceed with installation until unsatisfactory conditions have been corrected.

3.2 PREPARATION

- A. **Clean substrates** of projections and substances detrimental to application.
- B. **Condition finish carpentry** to average prevailing humidity conditions in installation areas before installation, for a minimum of 24 hours unless longer conditioning is recommended by manufacturer.

- C. **Prime and backprime** lumber for painted finish. Comply with requirements for surface preparation and application in Division 9 Section "Painting."

3.3 INSTALLATION, GENERAL

- A. **Do not use finish carpentry materials that are unsound**, warped, improperly treated or finished, inadequately seasoned, or too small to fabricate with proper jointing arrangements.
 - 1. Do not use manufactured units with defective surfaces, sizes, or patterns.
- B. **Install finish carpentry plumb**, level, true, and aligned with adjacent materials. Use concealed shims where required for alignment.
 - 1. Scribe and cut finish carpentry to fit adjoining work. Refinish and seal cuts as recommended by manufacturer.
 - 2. Countersink nails, fill surface flush, and sand where face nailing is unavoidable.
 - 3. Install to tolerance of 1/8 inch in 96 inches for plumb and level. Install adjoining finish carpentry with 1/32-inch maximum offset for flush installation and 1/16-inch maximum offset for reveal installation.
 - 4. Coordinate finish carpentry with materials and systems in or adjacent to standing and running trim and rails. Provide cutouts for mechanical and electrical items that penetrate exposed surfaces of trim and rails.
- C. **Window Sills:** Anchor securely by screwing through corner blocks or other supports into underside of window sills.
 - 1. Align adjacent solid-surfacing-material window sills and form seams to comply with manufacturer's written recommendations using adhesive in color to match countertop. Carefully dress joints smooth, remove surface scratches, and clean entire surface.
 - 2. Where windows are interior, provide solid-surfacing on both sides of the window unless a ceramic tile or wood window sill is indicated on the drawings.

3.4 STANDING AND RUNNING TRIM INSTALLATION

- A. **Install with minimum number of joints practical**, using full-length pieces from maximum lengths of lumber available. Do not use pieces less than 24 inches (610 mm) long, except where necessary. Stagger joints in adjacent and related standing and running trim. Cope at returns and miter at corners to produce tight-fitting joints with full-surface contact throughout length of joint. Use scarf joints for end-to-end joints. Plane backs of casings to provide uniform thickness across joints, if required.
 - 1. Match color and grain pattern across joints.
 - 2. Install trim after gypsum board joint finishing operations are completed.
 - 3. Drill pilot holes in hardwood before fastening to prevent splitting. Fasten to prevent movement or warping. Countersink fastener heads on exposed carpentry work and fill holes.

3.5 ADJUSTING

- A. **Repair damaged or defective finish carpentry** where possible to eliminate functional or visual defects. Where not possible to repair, replace finish carpentry. Adjust joinery for uniform appearance.

3.6 CLEANING

- A. **Clean finish carpentry** on exposed and semi-exposed surfaces. Touch up factory-applied finishes to restore damaged or soiled areas.

3.7 PROTECTION

- A. **Provide final protection** and maintain conditions that ensure finish carpentry is without damage or deterioration at the time of Substantial Completion.

END OF SECTION

THIS PAGE LEFT BLANK INTENTIONALLY

SECTION 06 4023

INTERIOR ARCHITECTURAL WOODWORK

PART 1 - GENERAL

1.1 RELATED DOCUMENTS

- A. Drawings and general provisions of the Contract, including General and Supplementary Conditions and Division 1 Specification Sections, apply to this Section.

1.2 SUMMARY

- A. This **Section includes** the following but is not limited to the following:
 - 1. Custom millwork.
 - 2. Laminate-clad cabinets.
 - 3. Plastic-laminate countertops.
 - 4. Solid-surface material countertops
- B. **Related Sections:**
 - 1. Section 06 2000 **"Finish Carpentry"** for solid surface material window sills.

1.3 DEFINITIONS

- A. **Interior architectural woodwork includes** wood furring, blocking, shims, and hanging strips for installing woodwork items unless concealed within other construction prior to woodwork installation.

1.4 SUBMITTALS

- A. **Product Data:** Product data for each type of product and process specified and incorporated into items of architectural woodwork during fabrication, finishing, and installation.
- B. **Shop Drawings:** Provide shop drawings showing location of each item, dimensioned plans and elevations, large-scale details, attachment devices, and other components.
 - 1. Show details full size.
 - 2. Show locations and sizes of furring, blocking, and hanging strips, including concealed blocking and reinforcing specified in other Sections.
- C. **Samples for verification of the following:**
 - 1. Plastic-laminate-clad panel products, 8 by 10 inches, for each type, color, pattern, and surface finish.
 - 2. Thermoset decorative-overlay surfaced panel products, 8 by 10, for each type, color, pattern, and surface finish.
 - 3. Exposed cabinet hardware, one unit for each type and finish.

1.5 QUALITY ASSURANCE

- A. **AWS Quality Standard:** Comply with applicable requirements of Architectural Woodwork Standards (AWS) - 2nd Edition, except as otherwise indicated.
- B. **Installer Qualifications:** Arrange for installation of architectural woodwork by a firm which can demonstrate successful experience in installing architectural woodwork items similar in type and quality to those required for this project.

- C. **Measurements:** Before proceeding with fabrication of woodwork required to be fitted to other construction, obtain field measurements and verify dimensions and shop drawing details as required for accurate fit.
- D. **Casework Integrity**
 - 1. Cabinets shall satisfy the AWS Appendix A testing standards: Structural Integrity Test, Concentrated Load Test, Torsion Test, Door Durability Test, Door Impact Test, Door Hinge Test, Drawer Bottom Impact Test, Drawer Support Test, Drawer And Door Pull Test, Drawer Rolling Load Test and Shelf Load Test.
- E. **Testing**
 - 1. The Owner reserves the right to take random sampling of casework components to verify that the materials and construction are as specified. In the event that one such sampling proves to be inferior to the requirements of the Contract Documents, it will be assumed the entire installation does not conform to the requirements. The supplier shall, at its own expense, replace components not conforming to the Contract Documents; the supplier shall provide the quality of casework required by the Contract Documents to the satisfaction of the Architect and Owner.

1.6 DELIVERY, STORAGE, AND HANDLING

- A. **Protect woodwork during transit,** delivery, storage, and handling to prevent damage, soilage, and deterioration.
- B. **Do not deliver woodwork** until painting and similar operations that could damage, soil, or deteriorate woodwork have been completed in installation areas. If woodwork must be stored in other than installation areas, store only in areas whose environmental conditions meet requirements specified in "Project Conditions."

1.7 PROJECT CONDITIONS

- A. **Environmental Limitations:** Do not deliver or install woodwork until building is enclosed, wet-work is completed, and HVAC system is operating and will maintain temperature and relative humidity at occupancy levels during the remainder of the construction period.
- B. **Field Measurements:** Where woodwork is indicated to be fitted to other construction, check actual dimensions of other construction by accurate field measurements before fabrication, and show recorded measurements on final shop drawings. Coordinate fabrication schedule with construction progress to avoid delaying the Work.
 - 1. Verify locations of concealed framing, blocking, reinforcements, and furring that support woodwork by accurate field measurements before being enclosed. Record measurements on final shop drawings.
 - 2. Where field measurements cannot be made without delaying the Work, guarantee dimensions and proceed with fabricating woodwork without field measurements. Provide allowance for trimming at site and coordinate construction to ensure that actual dimensions correspond to guaranteed dimensions.

1.8 COORDINATION

- A. **Coordinate sizes and locations of framing,** blocking, furring, reinforcements, and other related units of Work specified in other Sections to ensure that interior architectural woodwork can be supported and installed as indicated.

PART 2 - PRODUCTS

2.1 WOODWORK FABRICATORS

- A. **Fabricators:** Subject to compliance with requirements of Contract Documents, provide interior architectural woodwork by one of the following:
1. Huetter Mill and Cabinet Company.
 2. Granite Mill and Fixture Company.
 3. Swainston Mill.
 4. Johnson Brothers.
 5. Pacific Cabinets, Inc. of Ferdinand, ID.
 6. Fondell Woodwork.
 7. Artistic Mill
 8. Masterpiece Commercial Millwork
 9. Other mills may submit for approval no later than 10 days before the date for receipt of bids. Mills need not be members of AWI or WI to receive consideration, however, quality shall conform to levels outlined in these specifications.
- B. **Acceptable Laminate Manufacturers:** Subject to compliance with requirements of Contract Documents, provide products listed below. If not listed, submit as a substitution according to Conditions of the Contract and the requirements of Division 1 Sections.
1. WilsonArt.
 2. Pionite.
- C. **Acceptable Solid Surface Manufacturers:** Subject to compliance with requirements of Contract Documents, provide products listed below. If not listed, submit as a substitution according to Conditions of the Contract and the requirements of Division 1 Sections.
1. HI-MACS; LG Hausys.

2.2 MATERIALS

- A. **General:** Provide materials that comply with requirements of the AWI quality standard for each type of woodwork and quality grade indicated and, where the following products are part of interior woodwork, with requirements of the referenced product standards that apply to product characteristics indicated:
1. Hardboard: AHA A135.4.
 2. Particleboard: ANSI A208.1, Grade M-2, made with phenol-formaldehyde resins (no urea formaldehyde).
 3. Softwood Plywood: PS 1.
 4. Hardwood Plywood and Face Veneers: HPVA HP-1.
 - a. Match existing.
- B. **High-Pressure Decorative Laminate:** NEMA LD 3, grades as indicated, or if not indicated, as required by woodwork quality standard.
- C. **Adhesive for Bonding Plastic Laminate:** Contact cement.
- D. **Thermoset Decorative Overlay:** Decorative surface of thermally fused polyester or melamine-impregnated web, bonded to specified substrate and complying with ALA 1992.
1. Substrate: Medium-density particleboard.

E. Solid Surfacing:

1. Cast, nonporous, filled polymer, not coated, laminated or of composite construction with through body colors meeting ANSI Z124.3 or ANSI Z124.6, having minimum physical and performance properties specified.
2. Superficial damage to a depth of 0.010 inch shall be repairable by sanding and/or polishing.
3. Thickness: 1/2 inch (or maximum thickness available in selected color/texture).
4. Adhesives: As recommended by surfacing manufacturer for specific application.

2.3 MANUFACTURED UNITS

A. Cabinets:

1. Quality Standard: Comply with AWS Section 10, Custom grade, flush overlay design and the following:
2. Vertical Surface High Pressure Plastic Laminate:
 - a. High pressure plastic laminate for exterior surfaces shall be NEMA vertical grade 0.028-inch thickness, satin finish. Colors are to be selected from manufacturer's full color selection, including polished mirror types. Cabinet fronts for each individual cabinet shall be one color only.
 - b. Balancing sheet on inside of doors, drawer fronts and finished ends shall be high-pressure plastic laminate cabinet liner matching cabinet interior.
3. Horizontal Surface High Pressure Plastic Laminate: High-pressure plastic laminate for countertops and other horizontal surfaces shall be post-forming grade 0.039-inch thickness, satin finish. Colors to be selected from manufacturer's full color selection.
4. Thermo-Fused Melamine to Particle Board:
 - a. Melamine thermo-fused to a 45-pound density, or better particleboard substrate. Color: As selected by Architect from manufacturer's full range.
 - b. Melamine shall be standard for all cabinet interiors whether exposed or semi-exposed.
5. Hardboard:
 - a. Hardboard for dividers shall be 1/4 inch tempered hardboard smooth both sides. Color shall be dark brown.
 - b. Hardboard exposed one side for cabinet backs and drawer bottoms shall be 1/4 inch thick and pre-finished one side to match cabinet interiors.
6. Laminate Grade for Exposed Surfaces: Provide laminate cladding complying with the following requirements for type of surface and grade.
 - a. Horizontal Surfaces Other Than Tops: GP-50 (0.050-inch nominal thickness).
 - b. Postformed Surfaces: PF-42 (0.039-inch nominal thickness).
 - c. Colors: As indicated on Finish Schedule, Sheet A501.
7. Edge-banding:
 - a. Edge-banding for cabinet body parts shall be purified 0.020-inch PVC, applied with hot melt glue by automatic edge-banding equipment. Color shall be as selected by Architect from manufacturers full color range.
 - b. Edge-banding for door and drawer fronts shall be purified 3 mm PVC applied with hot melt glue by automatic edge-banding equipment. Edges and corners shall be rounded with a 3 mm radius and scraped free from machining or chatter marks. Color shall be as selected by Architect from manufacturers full color range.

2.4 MISCELLANEOUS MATERIALS

- A. Adhesives, General:** Adhesives shall not contain urea formaldehyde.

- B. **VOC Limits for Installation Adhesives:** Installation adhesives shall comply with the following limits for VOC content when calculated according to 40 CFR 59, Subpart D (EPA Method 24):
- a. Wood Glues: Not more than 30 g/L.
 - b. Multipurpose Construction Adhesives: 70 g/L.
 - c. Contact Adhesive: Not more than 250 g/L.

2.5 CABINET HARDWARE AND ACCESSORY MATERIALS

- A. **General:** Provide cabinet hardware and accessory materials associated with architectural cabinets, except for items specified in Division 8 Section "Door Hardware."
- B. **Finish Hardware:**
1. Hinges: Blum Self-Closing Inserta, #BH71T6540B, European style, clip-top 170-degree full overlay/self-closing type, steel with nickel-plated finish.
 2. Drawer Slides: Drawer slides for standard drawers shall be Blum BS230E or equal with 100-pound rating and baked enamel corrosion resistant finish. Drawer slides at drawers used to accommodate baby scale (top drawer in exam rooms and as indicated on Drawings), file drawers and paper drawer slides shall be KV 8500 or equal full extension with 100 pound rating.
 3. Pulls: Hafele, semi-circular tapered zinc pull with satin nickel finish, 128 mm C-to-C, model no. 104.35.600.
 4. Catches: Friction roller catch; Hafele 241.01.719 or Amerock 9823-2G.
 5. Adjustable Shelf Supports:
 - a. Adjustable shelves shall be supported on adjustable shelf supports inserted in shelf holes drilled into the case ends or partitions and adjustable on 1-1/2 inch centers. Supports to be KV 346 clips.
 6. Locks:
 - a. Locks for 3/4 inch hinged doors and where indicated on Drawings: National Lock #8053 disc tumbler. Locks to have a two level keying system, coordinate with Owner for master locks and keying system.
 - b. Locks for drawers in Exam rooms and where designated on Drawings: Safety 1st Magnetic Locking System Model HS132. Provide with magnetic keys.
 7. Coat Hooks: Wall mounted stained and lacquered hardwood multi-hook with brushed nickel-plated hooks that flip down.
 - a. Color: Natural
 - b. Size: 20 inches x 2 3/4 inches x 1 inch
 - c. Manufacturer: Umbra
 8. Shelf Standards and Brackets: Standards - KV 85 double slot heavy duty and brackets - KV 185 heavy duty double bracket. Standards to be 16 gauge steel. Brackets 12 inches or less: 16 gauge, 14 inches or greater: 14 gauge steel.
 9. File drawer slides: KV 8500 full extension.
 10. Screws: Reed and Prince square drive screws. Standard wood screws and sheet metal screws are not acceptable.
 11. Fully Articulated Keyboard Arm: Hafele, 639.96.305, Black Plastic, Black Steel.
 12. Keyboard Tray: Hafele, 639-96-396, Black Polymer Finish.
 13. Cable Grommets: HAFELE, 429.94.310, zinc die-cast, black finish.

2.6 INSTALLATION MATERIALS

- A. **Furring, Blocking, Shims, and Hanging Strips:** Softwood or hardwood lumber, kiln dried to less than 15 percent moisture content.
- B. **Screws:** Select material, type, size, and finish required for each use. Comply with ASME B18.6.1 for applicable requirements.
1. For metal framing supports, provide screws as recommended by metal-framing manufacturer.

- B. **Nails:** Select material, type, size, and finish required for each use. Comply with FS FF-N-105 for applicable requirements.
- D. **Anchors:** Select material, type, size, and finish required for each substrate for secure anchorage. Provide nonferrous metal or hot-dip galvanized anchors and inserts on inside face of exterior walls and elsewhere as required for corrosion resistance. Provide toothed steel or lead expansion bolt devices for drilled-in-place anchors.

2.7 FABRICATION

- A. **General:**
 - 1. **Wood Moisture Content:** Comply with requirements of referenced quality standard for moisture content of lumber at time of fabrication and for relative humidity conditions in the installation areas.
 - 2. **Dimensions and profiles:** Fabricate woodwork to dimensions, profiles, and details indicated with openings and mortises precut, where possible, to receive hardware and other items and work.
 - 3. **Edges:** Ease edges to a 1/16 inch radius, for corners of cabinets and edges of solid wood (lumber) members less than 1 inch in nominal thickness, 1/8 inch radius for edges of rails and similar members over 1 inch in nominal thickness.
 - 4. **Pre-assembly:** Complete fabrication, assembly, finishing, hardware application, and other work before shipment to project site to maximum extent possible. Disassemble components only as necessary for shipment and installation. Where necessary for fitting at site, provide ample allowance for scribing, trimming, and fitting.
 - 5. **Pre-Cut Openings:** Fabricate architectural woodwork with pre-cut openings, where possible, to receive hardware, appliances, plumbing fixtures, electrical work and similar items. Locate openings accurately and use templates or roughing-in diagrams for proper size and shape. Smooth edges of cutoffs and, where located in countertops and similar exposures seal edges of cutouts with a water-resistant coating.
 - 6. **Door and drawer fronts:** Doors, drawer fronts, and false fronts shall be flush overlay. They shall align vertically and horizontally and be on the same plane as one another. Shall be installed free of: warp, twisting, cupping, and/or bowing that cannot be held true; open joints, visible machine marks, cross-sanding, tear-outs, nicks, chips, and/or scratches

2.8 COMPONENT CONSTRUCTION

- A. **Toe Kicks:** Fixed cabinet bases shall be constructed of 3/4 inch exterior grade oriented strand board with 2x fir stringers height as shown on the drawings. Bases shall be leveled and anchored to the floor in continuing lengths to ensure straight and true lines of casework. Rubber, vinyl, or other finished base shall be furnished and installed by others.
- B. **Core Material:**
 - 1. **Particleboard:** Premium grade board of balanced construction with a density of 45 lbs. per cubic foot and moisture content of 8 percent or less. Face screw holding shall be a minimum of 320 lbs. withdrawal.
- C. **Case Body:**
 - 1. **Ends:** Case ends shall be 3/4 inch fused melamine laminated to thermo-fused melamine to core material with phenolic backer on concealed side. Exposed exterior cabinet ends shall be laminated with vertical grade high pressure plastic laminate. Exposed edges shall be edges with 0.020 inch PVC edge-banding. Holes shall be drilled for adjustable shelf supports at 1-1/4 inch centers.

2. Cabinet Top and Bottom:
 - a. Base and tall cabinet top and bottom shall be 3/4 inch thick with melamine thermo-fused to core material and phenolic backer sheets on concealed sides when semi-exposed. Provide plastic laminate if exposed to view.
 - b. Wall cabinet top and bottom shall be 3/4 inch thick except as noted below. Melamine thermo-fused to core material when semi-exposed. Provide plastic laminate if exposed to view.
 - 1) Provide bottoms of upper cabinets with a 50 lb per sq ft/ sq cm load capacity.
 - 2) Provide with thickness of 1 inch minimum when made with particleboard core and are 42 inch and over in length.
 - c. All exposed edges shall be banded with 0.020 inch PVC edge-banding.
 3. Adjustable Shelves:
 - a. Load is the total applied weight, uniformly dispersed on an individual shelf, not to exceed 200 lbs on any one shelf. Provide, per the AWS standards, the following load capacities:
 - 1) 50 lbs per sq ft for school, hospital, and library or book shelving.
 - 2) 40 lbs per sq ft for all other shelving
 - b. Deflection is the measured distance from a straight line that a shelf will deflect under load.
 - 1) L/144 (the length of the shelf divided by 144) is the industry standard for the maximum acceptable deflection of a shelf, which permits 1/4 inch deflection in a 36 inch shelf.
 - c. Adjustable shelves shall be 3/4 inch thick with melamine thermo-fused to core material on both sides for shelves up to 30 inch in width, and 1 inch thick for shelves over 30 inch in width.
 - d. Adjustable shelves in exposed or semi-exposed millwork shall be 3/4 inch thick with high-pressure plastic laminate on exterior surface on both sides for shelves up to 30 inch in width, and 1 inch thick for shelves over 30 inch in width.
 - e. Band exposed edges with 0.020 inch thick PVC.
 - f. All shelves to be adjustable on 32mm, 1 1/4 inch centers.
 4. Cabinet Backs:
 - a. Semi-exposed Cabinets: 1/4 inch thick pre-finished hardboard backed up with 4 inch x 3/4 inch hanging cleats on the back side.
 - b. Exposed Back shall be 1/2 inch thick with melamine thermo-fused to core material on interior, and high-pressure plastic laminate on exterior surface. The 1/2 inch is backed up with 4 inch x 1/2 inch hanging cleats on the back side.
 - c. Dado or plow cabinet backs into top, bottom and sides, with a minimum shoulder of 3/8 inch, securely nail or staple to the case body at a maximum of 4 inch on center.
 - d. Mount hanging cleats on backs for installation purposes, one top and one bottom in wall and base cabinets. Use three rails for all tall cabinets.
- D. **Doors and Drawer Fronts:**
1. Plastic Laminate Doors and Drawer Fronts: 3/4 inch thick for all hinged and sliding doors with vertical grade high pressure plastic laminate exterior face and color cabinet liner on interior face white.
 - a. Core material: 11/16 inch thick.
- E. **Drawers:**
1. Drawer Box Sides, Backs, and Sub-Fronts: 5/8 inch thick with melamine thermo-fused to 45 lb density particleboard. Exposed edges of box shall be banded with 0.020 inch thick PVC.

2. Drawer Bottoms: 1/4 inch thick pre-finished hardboard dadoed or plowed in into the sides, back and sub-front.
3. Fit file and paper storage drawers with a hood at back for paper retainage, and a 1/2 inch thick reinforced bottom dadoed or plowed in into the sides, back and sub-front.
4. Mount drawer fronts with an adjusting mechanism to allow full adjustability and alignment in field.
5. Vertical and Horizontal Dividers:
 - a. 1/4 inch tempered hardboard smooth both sides or 3/4 inch thermo-fused melamine mounted to 45 lb density particle board as required by cabinet construction requirements

F. Joinery:

1. All parts shall be accurately machined and fit for square and true, within a tolerance not to exceed 1/32 inch difference in measurement at top versus bottom, and 1/16 inch diagonally.
2. Dowel cabinet components into ends using 10mm hardwood dowels 4 inch on center maximum, securely glued. Space first dowel a maximum of 1-15/16 inch from each edge or end.
3. Drawer bodies shall be box type construction with detachable drawer fronts. Joints shall be securely fastened with hardwood dowels and glue.

2.9 LAMINATE PLASTIC COUNTERTOPS

A. Quality Standard: Comply with AWS Section 11 requirements for countertops.

1. Grade: Premium.

B. Type of Top: High-pressure decorative laminate complying with the following:

1. Grade: GP-50, 0.050-inch nominal thickness.
2. Colors, Patterns, and Finishes: Provide materials and products that result in colors and textures of exposed laminate surfaces complying with the following requirements:
 - a. Match color, pattern, and finish indicated by reference to manufacturer's standard designations for these characteristics.
 - b. Colors: As indicated on Legend-Finish Schedule or, if not indicated, as selected by Architect from manufacturer's full range including colors and patterns from all price ranges.
3. Edge Treatment: Same as laminate cladding on horizontal surfaces.
4. Core Material: Medium-density particleboard.

2.10 SOLID-SURFACING-MATERIAL COUNTERTOPS

A. Quality Standard: Comply with AWS Section 11 requirements for countertops.

1. Grade: Premium.

B. Solid-Surfacing-Material Thickness: 1/2 inch.

C. Colors, Patterns, and Finishes: Provide materials and products that result in colors of solid-surfacing material complying with the following requirements:

1. As indicated on Legend-Finish Schedule or, if not indicated, as selected by Architect from manufacturer's full range including colors and patterns from all price ranges.

D. Fabricate tops in one piece, unless otherwise indicated. Comply with solid-surfacing-material manufacturer's written recommendations for adhesives, sealers, fabrication, and finishing.

1. Fabricate tops with shop-applied edges of materials and configuration indicated.
2. Fabricate tops with shop-applied backsplashes.

PART 3 - EXECUTION

3.1 PREPARATION

- A. **Condition woodwork** to average prevailing humidity conditions in installation areas before installing.
- B. **Before installing architectural woodwork**, examine shop-fabricated work for completion and complete work as required, including back priming and removal of packing.

3.2 INSTALLATION

- A. **Install woodwork plumb**, level, true, and straight with no distortions. Shim as required with concealed shims. Install to a tolerance of 1/8 inch in 96 inches for plumb and level (including tops).
- B. **Scribe and cut woodwork** to fit adjoining work and refinish cut surfaces or repair damaged finish at cuts.
- C. **Anchor woodwork to anchors** or blocking built in or directly attached to substrates. Secure to grounds, stripping and blocking with countersunk, concealed fasteners and blind nailing as required for complete installation. Use fine finishing nails for exposed nailing, countersunk and filled flush with woodwork and matching final finish where transparent finish is indicated.
- D. **Cabinets:** Install without distortion so that doors and drawers fit openings properly and are accurately aligned. Adjust hardware to center doors and drawers in openings and to provide unencumbered operation. Complete the installation of hardware and accessory items as indicated.
 - 1. Install cabinets with no more than 1/8 inch in 96-inch sag, bow, or other variation from a straight line.
- E. **Tops:** Anchor securely to base units and other support systems as indicated. Calk space between backsplash and wall with specified sealant.
 - 1. Install countertops with no more than 1/8 inch in 96-inch sag, bow, or other variation from a straight line.
 - 2. Secure backsplashes to tops with concealed metal brackets at 16 inches o.c.
- F. **Complete the finishing** work specified in this Section to the extent not completed at shop or before installation of woodwork.

3.3 ADJUSTING AND CLEANING

- A. **Repair damaged and defective woodwork** where possible to eliminate functional and visual defects; where not possible to repair, replace woodwork. Adjust joinery for uniform appearance.
- B. **Clean, lubricate, and adjust** hardware.
- C. **Clean woodwork** on exposed and semi-exposed surfaces. Touch up shop-applied finishes to restore damaged or soiled areas.

3.4 PROTECTION

- A. **Provide final protection** and maintain conditions in a manner acceptable to fabricator and Installer that ensures that woodwork is without damage or deterioration at the time of Substantial Completion.

END OF SECTION

DIVISION 07 – THERMAL AND MOISTURE PROTECTION

Section 07 2116
Section 07 8400
Section 07 8443
Section 07 9200

Blanket Insulation
Through-Penetration Firestop Systems
Fire-Resistant Firestops and Joint Systems
Joint Sealants

THIS PAGE LEFT BLANK INTENTIONALLY

SECTION 07 2116

BLANKET INSULATION

PART 1 - GENERAL

1.1 RELATED DOCUMENTS

- A. Drawings and general provisions of the Contract, including General and Supplementary Conditions and Division 1 Specification Sections, apply to this Section.

1.2 SUMMARY

- A. **This Section includes** the following:
 - 1. Sound attenuation blankets.

1.3 SUBMITTALS

- A. **Product Data:** Provide product data for each type of insulation product specified.
- B. **Product Test Reports:** Provide product test reports from and based on tests performed by a qualified independent testing agency evidencing compliance of insulation products with specified requirements including those for thermal resistance, fire-test-response characteristics, water-vapor transmission, water absorption, and other properties, based on comprehensive testing of current products.

1.4 QUALITY ASSURANCE

- A. **Single-Source Responsibility for Insulation Products:** Obtain each type of building insulation from a single source with resources to provide products complying with requirements indicated without delaying the Work.
- B. **Fire-Test-Response Characteristics:** Provide insulation and related materials with the fire-test-response characteristics indicated on Drawings or specified elsewhere in this Section as determined by testing identical products per test method indicated below by UL or another testing and inspecting agency acceptable to authorities having jurisdiction. Identify materials with appropriate markings of applicable testing and inspecting agency.
 - 1. Surface-Burning Characteristics: ASTM E 84.
 - 2. Fire-Resistance Ratings: ASTM E 119.
 - 3. Combustion Characteristics: ASTM E 136.
- C. **Mock-Ups:** Before installing building insulation, build a mockup in an area or room as directed by the Architect, for each insulation condition to be a standard for insulation installation.
 - 1. Interior mock-up to include batt insulation, conditions where insulation is covered with gypsum board and where insulation is to be left exposed such as above ceilings.
 - 4. Approved mock-up may remain a part of the permanent construction, if undamaged prior to enclosure.

1.5 DELIVERY, STORAGE, AND HANDLING

- A. **Protection:** Protect insulation materials from physical damage and from deterioration by moisture, soiling, and other sources. Store inside and in a dry location. Comply with manufacturer's written instructions for handling, storing, and protecting during

installation.

PART 2 - PRODUCTS

2.1 MANUFACTURERS

- A. **Available Manufacturers:** Subject to compliance with requirements of Contract Documents, manufacturers offering insulation products that may be incorporated in the work include, but are not limited to, the following:
1. Glass-Fiber Insulation:
 - a. CertainTeed Corporation.
 - b. Knauf Fiber Glass GmbH.
 - c. Owens-Corning Fiberglas Corporation.
 - d. Johns Manville Corporation.

2.2 INSULATING MATERIALS

- A. **General:** Provide insulating materials that comply with requirements and with referenced standards.
- B. **Sound Attenuation Blankets:**
1. ASTM C 665, Type I; semi rigid mineral fiber blanket without membrane, Class 25 flame spread.
 2. Mineral-Fiber Type: Fibers manufactured from glass.
 3. Thickness: Furnish in 2-3/4 inch, 4 inch and 6 inch thicknesses or as required to achieve a minimum 50 STC in all walls.

PART 3 - EXECUTION

3.1 EXAMINATION

- A. **Examine substrates** and conditions, with Installer present, for compliance with requirements of Sections in which substrates and related work are specified and to determine if other conditions affecting performance of insulation are satisfactory. Do not proceed with installation until unsatisfactory conditions have been corrected. The Architect shall examine the installation of the insulation prior to insulation being covered by other work. If insulation is covered prior to Architects examination, Contractor shall remove other work, at Contractor's expense, to allow for Architect's examination.

3.2 PREPARATION

- A. **Clean substrates** of substances harmful to insulations or vapor retarders, including removing projections capable of puncturing vapor retarders or that interfere with insulation attachment.

3.3 INSTALLATION, GENERAL

- A. **Comply with insulation manufacturer's written instructions** applicable to products and application indicated.
- B. **Install insulation** that is undamaged, dry, unsoiled, and has not been exposed at any time to ice and snow.
- C. **Extend insulation** in thickness indicated to envelop entire area to be insulated. Cut and fit tightly around obstructions and fill voids with insulation. Remove projections that

interfere with placement.

- D. **Apply single layer of insulation** to produce thickness indicated, unless multiple layers are otherwise shown or required to make up total thickness.

3.4 INSTALLATION OF GENERAL BUILDING INSULATION (ABOVE GRADE)

- A. **Install mineral-fiber blankets** in cavities formed by framing members according to the following requirements:
 - 1. Use blanket widths and lengths that fill cavities formed by framing members. Where more than one length is required to fill cavity, provide lengths that will produce a snug fit between ends.
 - 2. Place blankets in cavities formed by framing members to produce a friction fit between edges of insulation and adjoining framing members.
 - 3. Insulation is to extend from floor to deck, typical.
- B. **Stuff glass-fiber loose-fill insulation** into miscellaneous voids and cavity spaces. Compact to approximately 40 percent of normal maximum volume equaling a density of approximately 2.5 lb/cu. ft.
- C. **Install acoustic blankets** above wood slat ceilings; butt edges tight together, hold ends back from exposed edges of ceiling system as needed for concealment, secure in place as recommended by manufacturer.

3.5 PROTECTION

- A. **General:** Protect installed insulation and vapor retarders from damage due to harmful weather exposures, physical abuse, and other causes. Provide temporary coverings or enclosures where insulation is subject to abuse and cannot be concealed and protected by permanent construction immediately after installation.

END OF SECTION

THIS PAGE LEFT BLANK INTENTIONALLY

SECTION 07 8400

THROUGH-PENETRATION FIRESTOP SYSTEMS

PART 1 - GENERAL

1.1 RELATED DOCUMENTS

- A. Drawings and general provisions of the Contract, including General and Supplementary Conditions and Division 1 Specification Sections, apply to this Section.

1.2 SUMMARY

- A. This **Section includes through-penetration firestop systems** for penetrations through the following fire-resistance-rated constructions, including both empty openings and openings containing penetrating items.
1. Floors.
 2. Roofs.
 3. Walls and partitions.
 4. Smoke barriers.
 5. Clips and other restraining devices necessary for holding fire protection material in place.
 6. Other items necessary for a complete and integral installation throughout the entire perimeter and other penetrations.
- B. **Related Sections** include the following:
1. Section 07 8443 "**Fire-Resistive Firestops and Joint Systems.**"
 2. Divisions 21 thru 23 Sections specifying **duct** and **pipng penetrations**.
 3. Divisions 26 thru 28 Sections specifying **cable** and **conduit penetrations**.

1.3 PERFORMANCE REQUIREMENTS

- A. **General:** For penetrations through the following fire-resistance-rated constructions, including both empty openings and openings containing penetrating items, provide through-penetration firestop systems that are produced and installed to resist spread of fire according to requirements indicated, resist passage of smoke and other gases, and maintain original fire-resistance rating of construction penetrated.
1. Fire-resistance-rated walls including fire walls, fire partitions, fire barriers, and smoke barriers.
 2. Fire-resistance-rated horizontal assemblies including floor/ceiling assemblies and ceiling membranes of roof/ceiling assemblies.
- B. **Rated Systems:** Provide through-penetration firestop systems with the following ratings determined per ASTM E 814 or UL 1479:
1. **F-Rated Systems:** Provide through-penetration firestop systems with F-ratings indicated, but not less than that equaling or exceeding fire-resistance rating of constructions penetrated.
 2. **T-Rated Systems:** For the following conditions, provide through-penetration firestop systems with T-ratings indicated, as well as F-ratings, where systems protect penetrating items exposed to potential contact with adjacent materials in occupiable floor areas:
 - a. Penetrations located outside wall cavities.
 - b. Penetrations located outside fire-resistance-rated shaft enclosures.
 3. **L-Rated Systems:** Where through-penetration firestop systems are indicated in smoke barriers, provide through-penetration firestop systems with L-ratings of not more than 3.0 cfm/sq. ft at both ambient temperatures and 400 degrees F.

- C. **For through-penetration firestop systems exposed to view**, traffic, moisture, and physical damage, provide products that, after curing, do not deteriorate when exposed to these conditions both during and after construction.
 - 1. For piping penetrations for plumbing and wet-pipe sprinkler systems, provide moisture-resistant through-penetration firestop systems.
 - 2. For floor penetrations with annular spaces exceeding 4 inches in width and exposed to possible loading and traffic, provide firestop systems capable of supporting floor loads involved, either by installing floor plates or by other means.
 - 3. For penetrations involving insulated piping, provide through-penetration firestop systems not requiring removal of insulation.
- D. **For through-penetration firestop systems exposed to view**, provide products with flame-spread and smoke-developed indexes of less than 25 and 450, respectively, as determined per ASTM E 84.

1.4 SUBMITTALS

- A. **Product Data:** For each type of product indicated.
- B. **LEED Submittals:**
 - 1. **Product Data for Credit IEQ 4.1:** For penetration firestopping sealants and sealant primers, documentation including printed statement of VOC content.
- C. **Shop Drawings:** For each through-penetration firestop system, show each type of construction condition penetrated, relationships to adjoining construction, and type of penetrating item. Include firestop design designation of qualified testing and inspecting agency that evidences compliance with requirements for each condition indicated.
 - 1. Submit documentation, including illustrations, from a qualified testing and inspecting agency that is applicable to each through-penetration firestop system configuration for construction and penetrating items.
- D. **Through-Penetration Firestop System Schedule:** Indicate locations of each through-penetration firestop system, along with the following information:
 - 1. Types of penetrating items.
 - 2. Types of constructions penetrated, including fire-resistance ratings and, where applicable, thicknesses of construction penetrated.
 - 3. Through-penetration firestop systems for each location identified by firestop design designation of qualified testing and inspecting agency.
 - 4. Where Project conditions require modification to a qualified testing and inspecting agency's illustration for a particular penetration firestopping condition, submit illustration, with modifications marked, approved by penetration firestopping manufacturer's fire-protection engineer as an engineering judgment or equivalent fire-resistance-rated assembly.
- E. **Qualification Data:** For Installer.
- F. **Product Test Reports:** From a qualified testing agency indicating through-penetration firestop system complies with requirements, based on comprehensive testing of current products.
- G. **Delegated Design/Deferred Submittal:** Supply documentation for each single application addressed. Documentation is to identify each penetration and joint location on the entire project. Submit to Architect and DFCM code official for review.

1.5 QUALITY ASSURANCE

- A. **Installer Qualifications:** A firm that has been approved by FMG according to FMG 4991, "Approval of Firestop Contractors."
- B. **Installation Responsibility:** Assign installation of through-penetration firestop systems and fire-resistive joint systems in Project to a single qualified installer.
- C. **Source Limitations:** Obtain through-penetration firestop systems, for each kind of penetration and construction condition indicated, through one source from a single manufacturer.
- D. **Fire-Test-Response Characteristics:** Provide through-penetration firestop systems that comply with the following requirements and those specified in Part 1 "Performance Requirements" Article:
 - 1. Firestopping tests are performed by a qualified testing and inspecting agency. A qualified testing and inspecting agency is UL or another agency performing testing and follow-up inspection services for firestop systems acceptable to authorities having jurisdiction.
 - 2. Through-penetration firestop systems are identical to those tested per testing standard referenced in "Part 1 Performance Requirements" Article. Provide rated systems complying with the following requirements:
 - a. Through-penetration firestop system products bear classification marking of qualified testing and inspecting agency.
 - b. Through-penetration firestop systems correspond to those indicated by reference to through-penetration firestop system designations listed by the following:
 - 1) UL in its "Fire Resistance Directory."
- E. **Pre-installation Conference:** Conduct conference at Project site to comply with requirements in Division 1 Section "Project Management and Coordination."

1.6 DELIVERY, STORAGE, AND HANDLING

- A. Deliver through-penetration firestop system products to Project site in original, unopened containers or packages with intact and legible manufacturers' labels identifying product and manufacturer, date of manufacture, lot number, shelf life if applicable, qualified testing and inspecting agency's classification marking applicable to Project, curing time, and mixing instructions for multicomponent materials.
- B. Store and handle materials for through-penetration firestop systems to prevent their deterioration or damage due to moisture, temperature changes, contaminants, or other causes.

1.7 PROJECT CONDITIONS

- A. **Environmental Limitations:** Do not install through-penetration firestop systems when ambient or substrate temperatures are outside limits permitted by through-penetration firestop system manufacturers or when substrates are wet due to rain, frost, condensation, or other causes.
- B. **Ventilate through-penetration firestop systems** per manufacturer's written instructions by natural means or, where this is inadequate, forced-air circulation.

1.8 COORDINATION

- A. Coordinate construction of openings and penetrating items to ensure that through-penetration firestop systems are installed according to specified requirements.
- B. Coordinate sizing of sleeves, openings, core-drilled holes, or cut openings to accommodate through-penetration firestop systems.
- C. Notify Owner's inspecting agency at least seven days in advance of through-penetration firestop system installations; confirm dates and times on days preceding each series of installations.
- D. Do not cover up through-penetration firestop system installations that will become concealed behind other construction until each installation has been examined by Owner's inspecting agency and building inspector, if required by authorities having jurisdiction.

PART 2 - PRODUCTS

2.1 MANUFACTURERS

- A. **Available Products:** Subject to compliance with requirements of Contract Documents, through-penetration firestop systems that may be incorporated into the Work include, but are not limited to, those systems indicated that are produced by one of the following manufacturers:
 - 1. GCP Applied Technologies.
 - 2. Hilti, Inc.
 - 3. Nelson Firestop Products.
 - 4. 3M; Fire Protection Products Division.
 - 5. Tremco; Sealant/Weatherproofing Division.

2.2 FIRESTOPPING, GENERAL

- A. **Compatibility:** Provide through-penetration firestop systems that are compatible with one another; with the substrates forming openings; and with the items, if any, penetrating through-penetration firestop systems, under conditions of service and application, as demonstrated by through-penetration firestop system manufacturer based on testing and field experience.
- B. **Accessories:** Provide components for each through-penetration firestop system that are needed to install fill materials and to comply with Part 1 "Performance Requirements" Article. Use only components specified by through-penetration firestop system manufacturer and approved by qualified testing and inspecting agency for firestop systems indicated.
- C. **Accessories include**, but are not limited to, the following items:
 - 1. Permanent forming/damming/backing materials, including the following:
 - a. Slag-/rock-wool-fiber insulation.
 - b. Sealants used in combination with other forming/damming/backing materials to prevent leakage of fill materials in liquid state.
 - c. Fire-rated form board.
 - d. Fillers for sealants.
 - 2. Temporary forming materials.
 - 3. Substrate primers.
 - 4. Collars.
 - 5. Steel sleeves.

2.3 FILL MATERIALS

- A. **General:** Provide through-penetration firestop systems containing the types of fill materials indicated. Fill materials are those referred to in directories of referenced testing and inspecting agencies as "fill," "void," or "cavity" materials.
- B. **Cast-in-Place Firestop Devices:** Factory-assembled devices for use in cast-in-place concrete floors and consisting of an outer metallic sleeve lined with an intumescent strip, a radial extended flange attached to one end of the sleeve for fastening to concrete formwork, and a neoprene gasket.
- C. **Latex Sealants:** Single-component latex formulations that after cure do not re-emulsify during exposure to moisture.
- D. **Firestop Devices:** Factory-assembled collars formed from galvanized steel and lined with intumescent material sized to fit specific diameter of penetrant.
- E. **Mortars:** Prepackaged dry mixes consisting of a blend of inorganic binders, hydraulic cement, fillers, and lightweight aggregate formulated for mixing with water at Project site to form a nonshrinking, homogeneous mortar.
- F. **Pillows/Bags:** Reusable heat-expanding pillows/bags consisting of glass-fiber cloth cases filled with a combination of mineral-fiber, water-insoluble expansion agents, and fire-retardant additives.
- G. **Silicone Foams:** Multicomponent, silicone-based liquid elastomers that, when mixed, expand and cure in place to produce a flexible, nonshrinking foam.
- H. **Silicone Sealants:** Single-component, silicone-based, neutral-curing elastomeric sealants of grade indicated below:
 - 1. **Grade:** Pourable (self-leveling) formulation for openings in floors and other horizontal surfaces, and nonsag formulation for openings in vertical and other surfaces requiring a nonslumping, gunnable sealant, unless indicated firestop system limits use to nonsag grade for both opening conditions.

2.4 MIXING

- A. **For those products requiring mixing before application,** comply with through-penetration firestop system manufacturer's written instructions for accurate proportioning of materials, water (if required), type of mixing equipment, selection of mixer speeds, mixing containers, mixing time, and other items or procedures needed to produce products of uniform quality with optimum performance characteristics for application indicated.

PART 3 - EXECUTION

3.1 EXAMINATION

- A. **Examine substrates and conditions,** with Installer present, for compliance with requirements for opening configurations, penetrating items, substrates, and other conditions affecting performance of work.
 - 1. Proceed with installation only after unsatisfactory conditions have been corrected.

3.2 PREPARATION

- A. **Surface Cleaning:** Clean out openings immediately before installing through-penetration firestop systems to comply with firestop system manufacturer's written instructions and with the following requirements:
 - 1. Remove from surfaces of opening substrates and from penetrating items foreign materials that could interfere with adhesion of through-penetration firestop systems.
 - 2. Clean opening substrates and penetrating items to produce clean, sound surfaces capable of developing optimum bond with through-penetration firestop systems. Remove loose particles remaining from cleaning operation.
 - 3. Remove laitance and form-release agents from concrete.

- B. **Priming:** Prime substrates where recommended in writing by through-penetration firestop system manufacturer using that manufacturer's recommended products and methods. Confine primers to areas of bond; do not allow spillage and migration onto exposed surfaces.

- C. **Masking Tape:** Use masking tape to prevent through-penetration firestop systems from contacting adjoining surfaces that will remain exposed on completion of Work and that would otherwise be permanently stained or damaged by such contact or by cleaning methods used to remove smears from firestop system materials. Remove tape as soon as possible without disturbing firestop system's seal with substrates.

3.3 THROUGH-PENETRATION FIRESTOP SYSTEM INSTALLATION

- A. **General:** Install through-penetration firestop systems to comply with Part 1 "Performance Requirements" Article and with firestop system manufacturer's written installation instructions and published drawings for products and applications indicated.

- B. **Install forming/damming/backing materials** and other accessories of types required to support fill materials during their application and in the position needed to produce cross-sectional shapes and depths required to achieve fire ratings indicated.
 - 1. After installing fill materials and allowing them to fully cure, remove combustible forming materials and other accessories not indicated as permanent components of firestop systems.

- C. **Install fill materials** for firestop systems by proven techniques to produce the following results:
 - 1. Fill voids and cavities formed by openings, forming materials, accessories, and penetrating items as required to achieve fire-resistance ratings indicated.
 - 2. Apply materials so they contact and adhere to substrates formed by openings and penetrating items.
 - 3. For fill materials that will remain exposed after completing Work, finish to produce smooth, uniform surfaces that are flush with adjoining finishes.

3.4 IDENTIFICATION

- A. **Identify through-penetration firestop systems** with preprinted metal or plastic labels. Attach labels permanently to surfaces adjacent to and within 6 inches (150 mm) of edge of the firestop systems so that labels will be visible to anyone seeking to remove penetrating items or firestop systems. Use mechanical fasteners for metal labels. For plastic labels, use self-adhering type with adhesives capable of permanently bonding labels to surfaces on which labels are placed and, in combination with label material, will result in partial destruction of label if removal is attempted. Include the following information on labels:
1. The words "Warning - Through-Penetration Firestop System - Do Not Disturb. Notify Building Management of Any Damage."
 2. Contractor's name, address, and phone number.
 3. Through-penetration firestop system designation of applicable testing and inspecting agency.
 4. Date of installation.
 5. Through-penetration firestop system manufacturer's name.
 6. Installer's name.

3.5 FIELD QUALITY CONTROL

- A. **Inspecting Agency:** Owner will engage a qualified, independent inspecting agency to inspect through-penetration firestops. Independent inspecting agency shall comply with ASTM E 2174 requirements including those related to qualifications, conducting inspections, and preparing test reports.
- B. **Where deficiencies are found**, repair or replace through-penetration firestop systems so they comply with requirements.
- C. **Proceed** with enclosing through-penetration firestop systems with other construction only after inspection reports are issued and firestop installations comply with requirements.

3.6 CLEANING AND PROTECTING

- A. **Clean off excess fill materials** adjacent to openings as Work progresses by methods and with cleaning materials that are approved in writing by through-penetration firestop system manufacturers and that do not damage materials in which openings occur.
- B. **Provide final protection** and maintain conditions during and after installation that ensure that through-penetration firestop systems are without damage or deterioration at time of Substantial Completion. If, despite such protection, damage or deterioration occurs, cut out and remove damaged or deteriorated through-penetration firestop systems immediately and install new materials to produce systems complying with specified requirements.

END OF SECTION

THIS PAGE LEFT BLANK INTENTIONALLY

SECTION 07 8443

FIRE-RESISTANT FIRESTOPS AND JOINT SYSTEMS

PART 1 - GENERAL

1.1 RELATED DOCUMENTS

- A. Drawings and general provisions of Contract, including General and Supplementary Conditions and Division-1 Specification Section, apply to work specified in this section.

1.2 SUMMARY

- A. **Section Includes:**
 - 1. Joints in or between fire-resistance-rated constructions.
 - 2. Joints at exterior curtain-wall/floor intersections.
 - 3. Joints in smoke barriers
 - 4. Anywhere indicated on Drawings.
- B. **Related Sections**
 - 1. Section 07 8400 "**Through-Penetration Firestop Systems**" for penetrations in fire-resistance-rated walls, horizontal assemblies, and smoke barriers.
 - 2. Section 07 9200 "**Joint Sealants**" for sealants applied to adjoining components.

1.3 DEFINITIONS

- A. **Firestopping:** Material or combination of materials used to retain integrity of fire-rated construction by maintaining an effective barrier against the spread of flame, smoke, and hot gases through penetrations in fire rated wall and floor assemblies.

1.4 REFERENCES

- A. **Underwriters Laboratories, Inc. (UL)** Fire Resistance Directory, Volume II, updated annually:
 - 1. Joint Systems (XHBN)
 - 2. Perimeter Fire Containment Systems (XHDG)
 - 3. Fire Resistance Ratings (BXRH)
 - 4. Fill, Voids, or Cavity Material (XHHW)
 - 5. Forming Materials (XHKU)
- B. **Omega Point Laboratories** (Intertek ITL Semko):
 - 1. Fire Resistant Joint Systems
- C. **ASTM International**
 - 1. ASTM E 1966, "Standard Test Method for Fire-Resistive Joint Systems"
 - 2. ASTM E 1399, "Test Method for Cyclic Movement and Measuring the Minimum and Maximum Joint Width of Architectural Joint Systems"
 - 3. ASTM E 84, "Standard Test Method for Surface Burning Characteristics of Building Materials"
 - 4. ASTM E 2174, "Standard Practice for On-Site Inspection of Installed Fire Stops"
 - 5. ASTM E 2307, "Standard Test Method for Determining the Fire Endurance of Perimeter Fire Barrier Systems Using Intermediate-Scale, Multi-story Test Apparatus"
- D. **ANSI/UL 2079**, "Tests for Fire Resistance of Building Joint Systems"

- E. **International Firestop Council (IFC)** "Recommended (IFC) Guidelines for Evaluating Firestop Systems Engineering Judgments".
- F. **IBC 2018**, as enforced by the State of Utah.
- G. **NFPA 101 - Life Safety Code**

1.5 QUALITY ASSURANCE

- A. **Installer Qualifications:** Experienced Installer who is certified, licensed, or otherwise qualified by the firestopping manufacturer as having been provided the necessary training to install manufacturer's products per specified requirements. A manufacturer's willingness to sell its firestopping products to the Contractor or to an Installer engaged by the Contractor does not in itself confer qualification on the buyer.
- B. **Manufacturer's direct representative** (not distributor or agent) to be on-site during initial installation of firestop systems to train appropriate contractor personnel in proper selection and installation procedures. This will be done per manufacturer's written recommendations published in their literature and drawing details.
- C. **Firestop System installation shall meet requirements of ASTM E 1966 or ANSI/UL 2079 tested and listed assemblies** that provide fire-resistance ratings not less than that of the construction in which the joint occurs.
- D. **Proposed firestop materials and methods** shall conform to applicable governing codes having local jurisdiction.
- E. **Firestop Systems do not reestablish the structural integrity** of load bearing partitions/assemblies, or support live loads and traffic. Installer shall consult the Structural Engineer prior to penetrating any load bearing assembly.
- F. **For those firestop applications that exist for which no tested and listed system is available through a manufacturer**, an engineering judgment derived from similar tested and listed system designs or other tests will be submitted to local authorities having jurisdiction for their review and approval prior to installation. Engineering judgment drawings shall follow requirements set forth by the International Firestop Council.

1.6 SUBMITTALS

- A. **Product Data:** Manufacturer's specifications and technical data for each material including the composition and limitations, documentation of tested and listed firestop systems to be used and manufacturer's installation instructions.
- B. **Sustainability Submittals:**
 - 1. For fire-resistive joint system sealants, documentation including printed statement of VOC content.
- C. **Manufacturer's engineering judgment identification number and drawing details** when no tested and listed system is available for an application. Engineering judgment shall include both project name and contractor's name who will install firestop system as described in drawing.
- D. **Deferred Submittal:** To be submitted to the Building Code Official for review.

1.7 DELIVERY, STORAGE, AND HANDLING

- A. **Deliver materials undamaged** in manufacturer's clearly labeled, unopened containers, identified with brand, type, and UL or OPL label, where applicable.
- B. **Coordinate delivery of materials** with scheduled installation date to allow minimum storage time at job-site.
- C. **Store materials under cover** and protect from weather and damage in compliance with manufacturer's requirements, including temperature restrictions.
- D. **Comply with recommended procedures**, precautions or remedies described in material safety data sheets as applicable.
- E. Do not use damaged or expired materials.

1.8 PROJECT CONDITIONS

- A. **Do not use** materials that contain **flammable solvents**.
- B. **Schedule installation** of firestopping after completion of penetrating item installation but prior to covering or concealing of openings.
- C. **Verify existing conditions** and substrates before starting work. Correct unsatisfactory conditions before proceeding.
- D. **Weather conditions:** Do not proceed with installation of firestop materials when temperatures exceed the manufacturer's recommended limitations for installation printed on product label and product data sheet.
- E. During installation, **provide masking and drop cloths** to prevent firestopping materials from contaminating any adjacent surfaces.

PART 2 - PRODUCTS

2.1 FIRESTOPPING, GENERAL

- A. **Provide firestopping** composed of components that are **compatible** with each other and substrates forming joints under conditions of service and application, as demonstrated by the firestopping manufacturer based on testing and field experience.
- B. **Provide components for each fire-resistive joint system** that are needed to install fill material. Use only components specified by the firestopping manufacturer and approved by the qualified testing agency for the designated fire-resistance-rated systems.

2.2 MANUFACTURERS

- A. **Acceptable Manufacturer:** Subject to compliance with requirements of Contract Documents, provide systems by the following manufacturer. Substitutions will not be considered.
 - 1. Manufacturer: Hilti, Inc.

2.3 MATERIALS

- A. Sealants for use with **fire-resistance-rated construction joints**:
 - 1. Hilti CP 672 Speed Spray
 - 2. Hilti CP 601s Elastomeric Firestop Sealant
 - 3. Hilti CP 606 Flexible Firestop Sealant
 - 4. Hilti CP 604 Self-leveling Firestop Sealant

- B. Sealants for use as part of a **Perimeter Fire Barrier System** between fire-resistance-rated floors and exterior wall assemblies:
 - 1. Hilti CFS SP WB Firestop Joint Spray
 - 2. Hilti CP 604 Self-leveling Firestop Sealant

- C. **Pre-formed mineral wool** designed to fit flutes of metal profile deck and gap between top of wall and metal deck profile; use as a backer for spray material.
 - 1. Hilti CP 777 Speed Plugs
 - 2. Hilti CP 767 Speed Strips

PART 3 - EXECUTION

3.1 PREPARATION

- A. **Verification of Conditions:** Examine areas and conditions under which work is to be performed and identify conditions detrimental to proper or timely completion.
 - 1. Surfaces to which firestop materials will be applied shall be free of dirt, grease, oil, rust, laitance, release agents, water repellents, and any other substances that may affect proper adhesion.
 - 2. Provide masking and temporary covering to prevent soiling of adjacent surfaces by firestopping materials.
 - 3. Comply with manufacturer's recommendations for temperature and humidity conditions before, during and after installation of firestopping.
 - 4. Do not proceed until unsatisfactory conditions have been corrected.

3.2 INSTALLATION

- A. **Regulatory Requirements:** Install firestop materials in accordance with UL Fire Resistance Directory or Omega Point Laboratories Listed Products Directory.

- B. **Manufacturer's Instructions:** Comply with manufacturer's instructions for installation of construction joint materials.
 - 1. Protect materials from damage on surfaces subjected to traffic.

3.3 FIELD QUALITY CONTROL

- A. **Examine sealed joints** to ensure proper installation before concealing or enclosing areas.

- B. **Keep areas of work accessible** until inspection by applicable code authorities and/or independent inspection agency.

- C. **Patch and repair damage** to firestopping caused by cutting or penetrating of existing firestop systems already installed by other trades.

3.4 ADJUSTING AND CLEANING

- A. **Remove equipment**, materials and debris, leaving area in undamaged, clean condition.
- B. **Clean surfaces** adjacent to sealed holes and joints to be free of excess firestop materials and soiling as work progresses.

END OF SECTION

THIS PAGE LEFT BLANK INTENTIONALLY

SECTION 07 9200

JOINT SEALANTS

PART 1 - GENERAL

1.1 RELATED DOCUMENTS

- A. Drawings and general provisions of the Contract, including General and Supplementary Conditions and Division 1 Specification Sections, apply to this Section.

1.2 SUMMARY

- A. **This Section includes** sealants for the following applications, including those specified by reference to this Section:
 - 1. Exterior joints in the following vertical surfaces and non-traffic horizontal surfaces:
 - a. Control and expansion joints in cast-in-place concrete.
 - b. Control and expansion joints in unit masonry.
 - c. Joints between different materials listed above.
 - d. Perimeter joints between materials listed above and frames of doors and windows.
 - e. Control and expansion joints in ceiling and overhead surfaces.
 - f. Other joints as indicated.
 - 2. Exterior joints in the following horizontal traffic surfaces:
 - a. Control, expansion, and isolation joints in cast-in-place concrete slabs.
 - b. Tile control and expansion joints.
 - c. Joints between different materials listed above.
 - 3. Interior joints in the following vertical surfaces and horizontal nontraffic surfaces:
 - a. Control and expansion joints on exposed interior surfaces of exterior walls
 - b. Perimeter joints of exterior openings where indicated.
 - c. Tile control and expansion joints.
 - d. Vertical control joints on exposed surfaces of interior unit masonry and concrete walls and partitions.
 - e. Perimeter joints between interior wall surfaces and frames of interior doors, windows, and elevator entrances.
 - f. Joints between plumbing fixtures and adjoining walls, floors, and counters.
 - g. Joints between interior partitions and concrete floors.
 - h. Other joints as indicated.
 - 4. Interior joints in the following horizontal traffic surfaces:
 - a. Control and expansion joints in cast-in-place concrete slabs.
 - b. Control and expansion joints in tile flooring.
 - c. Other joints as indicated.
 - 5. All joints between dissimilar materials.
- B. **Related Sections** include the following:
 - 1. Section 09 2900 "**Gypsum Board**" for sealing perimeter joints of gypsum board partitions to reduce sound transmission.
 - 2. Section 09 5100 "**Acoustical Panel Ceilings**" for sealing edge moldings at perimeters of acoustical ceilings.

1.3 PERFORMANCE REQUIREMENTS

- A. **Provide elastomeric joint sealants** that establish and maintain watertight and airtight continuous joint seals without staining or deteriorating joint substrates.

1.4 SUBMITTALS

- A. **Product Data:** For each joint-sealant product indicated.
- B. **Samples for Selection:** Manufacturer's color charts consisting of strips of cured sealants showing the full range of colors available for each product exposed to view.
- C. **Product Certificates:** Signed by manufacturers of joint sealants certifying that products furnished comply with requirements and are suitable for the use indicated.

1.5 QUALITY ASSURANCE

- A. **Installer Qualifications:** An experienced installer who has specialized in installing joint sealants similar in material, design, and extent to those indicated for this Project and whose work has resulted in joint-sealant installations with a record of successful in-service performance.
- B. **Source Limitations:** Obtain each type of joint sealant through one source from a single manufacturer.
- C. **Preconstruction Compatibility and Adhesion Testing:** Submit to joint sealant manufacturers, for testing indicated below, samples of materials that will contact or affect joint sealants.
 - 1. Use manufacturers standard test methods to determine whether priming and other specific joint preparation techniques are required to obtain rapid, optimum adhesion of joint sealants to joint substrates.
 - a. Perform tests under environmental conditions replicating those that will exist during installation.
 - 2. Submit not fewer than nine pieces of each type of material, including joint substrates, shims, joint-sealant backings, secondary seals, and miscellaneous materials.
 - 3. Schedule sufficient time for testing and analyzing results to prevent delaying the Work.
 - 4. For materials failing tests, obtain joint sealant manufacturer's written instructions for corrective measures, including the use of specially formulated primers.
 - 5. Testing will not be required if joint sealant manufacturers submit joint preparation data that are based on previous testing of current sealant products for adhesion to, and compatibility with, joint substrates and other materials matching those submitted.
- D. **Mockups:** Before installing joint sealants, apply elastomeric sealants as follows to verify color selections and to demonstrate aesthetic effects and qualities of materials and execution:
 - 1. Joints in mockups of assemblies specified in other Sections that are indicated to receive elastomeric joint sealants, which are specified by reference to this Section.
 - 2. Provide mockup samples of sealants and caulks for Owner and Architect review. Provide mockups of each type of sealant and caulk, in 3 colors, minimum. Mockup samples shall be at least 12 inches long and the width and depth of the joint. Samples shall be installed at floors, walls, ceiling and other locations selected by Architect on the Project site.

1.6 DELIVERY, STORAGE, AND HANDLING

- A. **Deliver materials** to Project site in original unopened containers or bundles with labels indicating manufacturer, product name and designation, color, expiration date, pot life, curing time, and mixing instructions for multicomponent materials.
- B. **Store and handle materials** in compliance with manufacturer's written instructions to prevent their deterioration or damage due to moisture, high or low temperatures, contaminants, or other causes.

1.7 PROJECT CONDITIONS

- A. **Environmental Limitations:** Do not proceed with installation of joint sealants under the following conditions:
 - 1. When ambient and substrate temperature conditions are outside limits permitted by joint sealant manufacturer.
 - 2. When joint substrates are wet.
- B. **Joint-Width Conditions:** Do not proceed with installation of joint sealants where joint widths are less than those allowed by joint sealant manufacturer for applications indicated.
- C. **Joint-Substrate Conditions:** Do not proceed with installation of joint sealants until contaminants capable of interfering with adhesion are removed from joint substrates.

1.8 WARRANTY

- A. **Special Installer's Warranty:** Installer's standard form in which Installer agrees to repair or replace elastomeric joint sealants that do not comply with performance and other requirements specified in this Section within specified warranty period.
 - 1. Warranty Period: Three years from date of Substantial Completion.
- B. **Special Manufacturer's Warranty:** Manufacturer's standard form in which joint sealant manufacturer agrees to repair or replace sealants that do not comply with performance and other requirements specified in this Section.
 - 1. Warranty Period: Twenty years from date of Substantial Completion.
- C. **Special warranties** specified in this Article **exclude** deterioration or failure of elastomeric joint sealants from the following:
 - 1. Movement of the structure resulting in stresses on the sealant exceeding sealant manufacturer's written specifications for sealant elongation and compression caused by structural settlement or errors attributable to design or construction.
 - 2. Disintegration of joint substrates from natural causes exceeding design specifications.
 - 3. Mechanical damage caused by individuals, tools, or other outside agents.
 - 4. Changes in sealant appearance caused by accumulation of dirt or other atmospheric contaminants.

PART 2 - PRODUCTS

2.1 MATERIALS, GENERAL

- A. **Compatibility:** Provide joint sealants, backings, and other related materials that are compatible with one another and with joint substrates under conditions of service and application, as demonstrated by sealant manufacturer based on testing and field experience.

- B. **Colors of Exposed Joint Sealants:** As selected by Architect from manufacturer's full range for this characteristic.

2.2 ELASTOMERIC JOINT SEALANTS

- A. **Elastomeric Sealant Standard:** Comply with ASTM C 920 and other requirements indicated for each liquid-applied chemically curing sealant in the Elastomeric Joint-Sealant Schedule at the end of Part 3, including those referencing ASTM C 920 classifications for type, grade, class, and uses.
- B. **Additional Movement Capability:** Where additional movement capability is specified in the Elastomeric Joint-Sealant Schedule, provide products with the capability, when tested for adhesion and cohesion under maximum cyclic movement per ASTM C 719, to withstand the specified percentage change in the joint width existing at the time of installation and remain in compliance with other requirements of ASTM C 920 for uses indicated.
- C. **Suitability for Contact with Food:** Where elastomeric sealants are indicated for joints that will come in repeated contact with food, provide products that comply with 21 CFR 177.2600.

2.3 SOLVENT-RELEASE JOINT SEALANTS

- A. **Acrylic-Based Solvent-Release Joint-Sealant Standard:** Comply with ASTM C 1311 for each product of this description indicated in the Solvent-Release Joint-Sealant Schedule at the end of Part 3.
- B. **Butyl-Rubber-Based Solvent-Release Joint-Sealant Standard:** Comply with ASTM C 1085 for each product of this description indicated in the Solvent-Release Joint-Sealant Schedule at the end of Part 3.

2.4 LATEX JOINT SEALANTS

- A. **Latex Sealant Standard:** Comply with ASTM C 834 for each product of this description indicated in the Latex Joint-Sealant Schedule at the end of Part 3.

2.5 ACOUSTICAL JOINT SEALANTS

- A. **Acoustical Sealant for Exposed and Concealed Joints:** For each product of this description indicated in the Acoustical Joint-Sealant Schedule at the end of Part 3, provide manufacturer's standard non-sag, paintable, non-staining latex sealant complying with ASTM C 834 and the following:
 1. Product effectively reduces airborne sound transmission through perimeter joints and openings in building construction as demonstrated by testing representative assemblies according to ASTM E 90.

2.6 JOINT-SEALANT BACKING

- A. **General:** Provide sealant backings of material and type that are non-staining; are compatible with joint substrates, sealants, primers, and other joint fillers; and are approved for applications indicated by sealant manufacturer based on field experience and laboratory testing.

- B. **Cylindrical Sealant Backings:** ASTM C 1330, of type indicated below and of size and density to control sealant depth and otherwise contribute to producing optimum sealant performance:
 - 1. Type C: Closed-cell material with a surface skin.
- C. **Elastomeric Tubing Sealant Backings:** Neoprene, butyl, EPDM, or silicone tubing complying with ASTM D 1056, nonabsorbent to water and gas, and capable of remaining resilient at temperatures down to minus 26 degrees F. Provide products with low compression set and of size and shape to provide a secondary seal, to control sealant depth, and otherwise contribute to optimum sealant performance.
- D. **Bond-Breaker Tape:** Polyethylene tape or other plastic tape recommended by sealant manufacturer for preventing sealant from adhering to rigid, inflexible joint-filler materials or joint surfaces at back of joint where such adhesion would result in sealant failure. Provide self-adhesive tape where applicable.

2.7 MISCELLANEOUS MATERIALS

- A. **Primer:** Material recommended by joint sealant manufacturer where required for adhesion of sealant to joint substrates indicated, as determined from preconstruction joint-sealant-substrate tests and field tests.
- B. **Cleaners for Nonporous Surfaces:** Chemical cleaners acceptable to manufacturers of sealants and sealant backing materials, free of oily residues or other substances capable of staining or harming joint substrates and adjacent nonporous surfaces in any way, and formulated to promote optimum adhesion of sealants with joint substrates.
- C. **Masking Tape:** Nonstaining, nonabsorbent material compatible with joint sealants and surfaces adjacent to joints.

PART 3 - EXECUTION

3.1 EXAMINATION

- A. All joints of **dissimilar materials** to receive joint sealant.
- B. **Examine joints** to receive joint sealants, with Installer present, for compliance with requirements for joint configuration, installation tolerances, and other conditions affecting joint-sealant performance.
- C. **Proceed with installation** only after unsatisfactory conditions have been corrected.

3.2 PREPARATION

- A. **Surface Cleaning of Joints:** Clean out joints immediately before installing joint sealants to comply with joint sealant manufacturer's written instructions and the following requirements:
 - 1. Remove all foreign material from joint substrates that could interfere with adhesion of joint sealant, including dust, paints (except for permanent, protective coatings tested and approved for sealant adhesion and compatibility by sealant manufacturer), old joint sealants, oil, grease, waterproofing, water repellents, water, surface dirt, and frost.

2. Clean porous joint substrate surfaces by brushing, grinding, blast cleaning, mechanical abrading, or a combination of these methods to produce a clean, sound substrate capable of developing optimum bond with joint sealants. Remove loose particles remaining from above cleaning operations by vacuuming or blowing out joints with oil-free compressed air. Porous joint surfaces include concrete, masonry or unglazed surfaces of ceramic tile.
 3. Remove laitance and form-release agents from concrete.
 4. Clean nonporous surfaces with chemical cleaners or other means that do not stain, harm substrates, or leave residues capable of interfering with adhesion of joint sealants to metal, glass, porcelain enamel or glazed surfaces of ceramic tile.
- B. **Joint Priming:** Prime joint substrates where recommended in writing by joint sealant manufacturer, based on preconstruction joint-sealant-substrate tests or prior experience. Apply primer to comply with joint sealant manufacturer's written instructions. Confine primers to areas of joint-sealant bond; do not allow spillage or migration onto adjoining surfaces.
- C. **Masking Tape:** Use masking tape where required to prevent contact of sealant with adjoining surfaces that otherwise would be permanently stained or damaged by such contact or by cleaning methods required to remove sealant smears. Remove tape immediately after tooling without disturbing joint seal.

3.3 INSTALLATION OF JOINT SEALANTS

- A. **General:** Comply with joint sealant manufacturer's written installation instructions for products and applications indicated, unless more stringent requirements apply.
- B. **Sealant Installation Standard:** Comply with recommendations of ASTM C 1193 for use of joint sealants as applicable to materials, applications, and conditions indicated.
- C. **Acoustical Sealant Application Standard:** Comply with recommendations of ASTM C 919 for use of joint sealants in acoustical applications as applicable to materials, applications, and conditions indicated.
- D. **Install sealant backings** of type indicated to support sealants during application and at position required to produce cross-sectional shapes and depths of installed sealants relative to joint widths that allow optimum sealant movement capability.
1. Do not leave gaps between ends of sealant backings.
 2. Do not stretch, twist, puncture, or tear sealant backings.
 3. Remove absorbent sealant backings that have become wet before sealant application and replace them with dry materials.
- E. **Install bond-breaker tape** behind sealants where sealant backings are not used between sealants and back of joints.
- F. **Install sealants** by proven techniques to comply with the following and at the same time backings are installed:
1. Place sealants so they directly contact and fully wet joint substrates.
 2. Completely fill recesses provided for each joint configuration.
 3. Produce uniform, cross-sectional shapes and depths relative to joint widths that allow optimum sealant movement capability.
 4. Seal abutting joint at all dissimilar materials.

- G. **Tooling of Nonsag Sealants:** Immediately after sealant application and before skinning or curing begins, tool sealants according to requirements specified below to form smooth, uniform beads of configuration indicated; to eliminate air pockets; and to ensure contact and adhesion of sealant with sides of joint.
1. Remove excess sealants from surfaces adjacent to joint.
 2. Use tooling agents that are approved in writing by sealant manufacturer and that do not discolor sealants or adjacent surfaces.
 3. Provide concave joint configuration per Figure 5A in ASTM C 1193, unless otherwise indicated.
 4. Provide flush joint configuration, per Figure 5B in ASTM C 1193, where indicated.
 5. Provide recessed joint configuration, per Figure 5C in ASTM C 1193, of recess depth and at locations indicated.
 - a. Use masking tape to protect adjacent surfaces of recessed tooled joints.

3.4 CLEANING

- A. **Clean off excess sealants** or sealant smears adjacent to joints as the Work progresses by methods and with cleaning materials approved in writing by manufacturers of joint sealants and of products in which joints occur.

3.5 PROTECTION

- A. **Protect joint sealants** during and after curing period from contact with contaminating substances and from damage resulting from construction operations or other causes so sealants are without deterioration or damage at time of Substantial Completion. If, despite such protection, damage or deterioration occurs, cut out and remove damaged or deteriorated joint sealants immediately so installations with repaired areas are indistinguishable from the original work.

3.6 ELASTOMERIC JOINT-SEALANT SCHEDULE

- A. **Medium-Modulus Neutral-Curing Silicone Sealant:**
1. Available Products: Subject to compliance with requirements of Contract Documents, products which may be incorporated into the Work include, but are not limited to, the following:
 - a. 791; Dow Corning.
 - b. PSI-631; Polymeric Systems, Inc.
 - c. MasterSeal NP 150, BASF.
 - d. Spectrem 2; Tremco.
 2. Type and Grade: S (single component) and NS (nonsag).
 3. Class: 25.
 4. Use Related to Exposure: NT (nontraffic).
 5. Uses Related to Joint Substrates: M (masonry), G (glass), A (aluminum), and, as applicable to joint substrates indicated, O (other).
 - a. Use O Joint Substrates: Coated glass, color anodic aluminum, aluminum coated with a high-performance coating, galvanized steel, brick and masonry, ceramic tile, and wood.
 6. Stain-Test-Response Characteristics: Nonstaining to porous substrates per ASTM C 1248.
 7. Applications: Exterior and interior joints in vertical surfaces of concrete; between metal and concrete and mortar; perimeter of metal frames in exterior walls; overhead or ceiling joints.

B. Mildew-Resistant Silicone Sealant:

1. Available Products: Subject to compliance with requirements of Contract Documents, products which may be incorporated into the Work include, but are not limited to, the following:
 - a. 786 Mildew Resistant; Dow Corning.
 - b. Sanitary 1700; GE Silicones.
 - c. Tremsil 600 White; Tremco.
 - d. MasterSeal NP 150, BASF.
2. Type and Grade: S (single component) and NS (nonsag); formulated with fungicide.
3. Class: 25.
4. Use Related to Exposure: NT (nontraffic); intended for sealing interior ceramic tile joints and other nonporous substrates that are subject to in-service exposures of high humidity and temperature extremes.
5. Uses Related to Joint Substrates: G, A, and, as applicable to joint substrates indicated, O.
 - a. Use O Joint Substrates: Coated glass, color anodic aluminum, aluminum coated with a high-performance coating, galvanized steel, and ceramic tile.
6. Applications: Interior joints in vertical surfaces of ceramic tile in toilet rooms, and showers.

C. Multicomponent Pourable Urethane Sealant:

1. Available Products: Subject to compliance with requirements of Contract Documents, products which may be incorporated into the Work include, but are not limited to, the following:
 - a. Vulkem 245; Mameco International.
 - b. Elasto-Thane 920 Pourable; Pacific Polymers, Inc.
 - c. Sikaflex - 2c SL; Sika Corporation.
 - d. MasterSeal SL 2; BASF.
2. Type and Grade: M (multicomponent) and P (pourable).
3. Class: 25.
4. Uses Related to Exposure: T (traffic) and NT (nontraffic).
5. Uses Related to Joint Substrates: M, A, and, as applicable to joint substrates indicated, O.
 - a. Use O Joint Substrates: Coated glass, color anodic aluminum, aluminum coated with a high-performance coating, galvanized steel, brick and masonry, ceramic tile, and wood.
6. Applications: Traffic joints.

D. Single-Component Nonsag Urethane Sealant:

1. Available Products: Subject to compliance with requirements of Contract Documents, products which may be incorporated into the Work include, but are not limited to, the following:
 - a. Vulkem 921; Mameco International.
 - b. Dynatrol I; Pecora Corporation.
 - c. DyMonic; Tremco.
 - d. MasterSeal NP1, BASF.
2. Type and Grade: S (single component) and NS (nonsag).
3. Class: 25
4. Use Related to Exposure: NT (nontraffic).
5. Uses Related to Joint Substrates: M, A, and, as applicable to joint substrates indicated, O.
 - a. Use O Joint Substrates: Coated glass, color anodic aluminum, aluminum coated with a high-performance coating, galvanized steel, brick and masonry, ceramic tile, and wood.
6. Applications: Joints in concrete.

3.7 LATEX JOINT-SEALANT SCHEDULE

A. Latex Sealant:

1. Available Products: Subject to compliance with requirements of Contract Documents, products which may be incorporated into the Work include, but are not limited to, the following:
 - a. AC-20; Pecora Corporation.
 - b. Tremflex 834; Tremco.
2. Applications: Interior joints in field-painted vertical and overhead surfaces at hollow metal door frames, gypsum drywall, and concrete; and all other interior locations not indicated otherwise.

3.8 ACOUSTICAL JOINT-SEALANT SCHEDULE

A. Acoustical Sealant for Exposed and Concealed Joints:

1. Available Products: Subject to compliance with requirements of Contract Documents, products which may be incorporated into the Work include, but are not limited to, the following:
 - a. AC-20 FTR Acoustical and Insulation Sealant; Pecora Corporation.
 - b. SHEETROCK Acoustical Sealant; USG Corp., United States Gypsum Co.
 - c. SpecSeal® Smoke 'N' Sound Acoustical Sealant; STI.
2. Applications: Use in locations of sound walls and in locations indicated.

END OF SECTION

THIS PAGE LEFT BLANK INTENTIONALLY

DIVISION 08 – OPENINGS

Section 08 1113	Hollow Metal Doors and Frames
Section 08 1416	Flush Wood Doors
Section 08 3100	Access Doors and Frames
Section 08 7100	Door Hardware
Section 08 8000	Glazing
Section 08 8816	Vision Control Glass

THIS PAGE LEFT BLANK INTENTIONALLY

SECTION 08 1113

HOLLOW METAL DOORS AND FRAMES

PART 1 - GENERAL

1.1 RELATED DOCUMENTS

- A. Drawings and general provisions of the Contract, including General and Supplementary Conditions and Division 1 Specification Sections, apply to this Section.

1.2 SUMMARY

- A. **Section Includes:**
 - 1. Hollow metal doors and frames.
- B. **Related Sections**
 - 1. Section 08 1416 "**Flush Wood Doors**" for wood doors installed in steel frames.
 - 2. Section 08 7100 "**Door Hardware**" for door hardware for hollow metal doors.
 - 3. Section 08 8000 "**Glazing**" for glass in glazed openings.
 - 4. Section 09 2900 "**Gypsum Board**" for spot grouting frames installed in steel framed gypsum board partitions
 - 5. Sections 09 9100 "**Painting**" for field painting hollow metal doors and frames.

1.3 DEFINITIONS

- A. **Minimum Thickness:** Minimum thickness of base metal without coatings.
- B. **Standard Hollow Metal Work:** Hollow metal work fabricated according to ANSI/SDI A250.8.

1.4 SUBMITTALS

- A. **Product Data:** For each type of product indicated. Include construction details, material descriptions, core descriptions, fire-resistance rating, temperature-rise ratings, and finishes.
- B. **Shop Drawings:** Include the following:
 - 1. Elevations of each door and window frame design.
 - 2. Details of doors, including vertical and horizontal edge details and metal thicknesses.
 - 3. Frame details for each frame type, including dimensioned profiles and metal thicknesses.
 - 4. Locations of reinforcement and preparations for hardware.
 - 5. Details of each different wall opening condition.
 - 6. Details of anchorages, joints, field splices, and connections.
 - 7. Details of accessories.
 - 8. Details of moldings, removable stops, and glazing.
- C. **Other Action Submittals:**
 - 1. **Schedule:** Provide a schedule of hollow metal work prepared by or under the supervision of supplier, using same reference numbers for details and openings as those on Drawings. Coordinate with door hardware schedule.

- D. **Product Test Reports:** Based on evaluation of comprehensive tests performed by a qualified testing agency, for each type of hollow metal door and frame assembly.

1.5 QUALITY ASSURANCE

- A. **Source Limitations:** Obtain hollow metal work from single source from single manufacturer.

1.6 DELIVERY, STORAGE, AND HANDLING

- A. **Deliver** hollow metal work palletized, wrapped, or crated to provide protection during transit and Project-site storage. Do not use nonvented plastic.
 - 1. Provide additional protection to prevent damage to finish of factory-finished units.
- B. **Deliver welded frames** with two removable spreader bars across bottom of frames, tack welded to jambs and mullions.
- C. **Store hollow metal work under cover at Project site.** Place in stacks of five units maximum in a vertical position with heads up, spaced by blocking, on minimum 4-inch-high wood blocking. Do not store in a manner that traps excess humidity.
 - 1. Provide minimum 1/4-inch space between each stacked door to permit air circulation.

1.7 PROJECT CONDITIONS

- A. **Field Measurements:** Verify actual dimensions of openings by field measurements before fabrication.

1.8 COORDINATION

- A. **Coordinate installation** of anchorages for hollow metal frames. Furnish setting drawings, templates, and directions for installing anchorages, including sleeves, concrete inserts, anchor bolts, and items with integral anchors. Deliver such items to Project site in time for installation.

PART 2 - PRODUCTS

2.1 MANUFACTURERS

- A. **Available Manufacturers:** Subject to compliance with requirements of Contract Documents, available manufacturers offering products that may be incorporated into the Work include, but are not limited to, the following:
 - 1. Amweld Building Products, LLC.
 - 2. Ceco Door Products; an Assa Abloy Group company.
 - 3. Curries Company; an Assa Abloy Group company.
 - 4. Pioneer Industries, Inc.
 - 5. Steelcraft; an Allegion company.
 - 6. Republic Doors.
 - 7. Security Metal Products Corp.

2.2 MATERIALS

- A. **Cold-Rolled Steel Sheet:** ASTM A 1008/A 1008M, Commercial Steel (CS), Type B; suitable for exposed applications.

- B. **Hot-Rolled Steel Sheet:** ASTM A 1011/A 1011M, Commercial Steel (CS), Type B; free of scale, pitting, or surface defects; pickled and oiled.
- C. **Metallic-Coated Steel Sheet:** ASTM A 653/A 653M, Commercial Steel (CS), Type B; with minimum A40 (ZF120) metallic coating.
- D. **Frame Anchors:** ASTM A 591/A 591M, Commercial Steel (CS), 40Z (12G) coating designation; mill phosphatized.
 - 1. For anchors built into exterior walls, steel sheet complying with ASTM A 1008/A 1008M or ASTM A 1011/A 1011M, hot-dip galvanized according to ASTM A 153/A 153M, Class B.
- E. **Inserts, Bolts, and Fasteners:** Hot-dip galvanized according to ASTM A 153/A 153M.
- F. **Powder-Actuated Fasteners in Concrete:** Fastener system of type suitable for application indicated, fabricated from corrosion-resistant materials, with clips or other accessory devices for attaching hollow metal frames of type indicated.
- G. **Grout:** ASTM C 476, except with a maximum slump of 4 inches, as measured according to ASTM C 143/C 143M.
- H. **Mineral-Fiber Insulation:** ASTM C 665, Type I (blankets without membrane facing); consisting of fibers manufactured from slag or rock wool with 6- to 12-lb/cu. ft. density; with maximum flame-spread and smoke-development indexes of 25 and 50, respectively; passing ASTM E 136 for combustion characteristics.
- I. **Glazing:** Comply with requirements in Division 8 Section "Glazing."
- J. **Bituminous Coating:** Cold-applied asphalt mastic, SSPC-Paint 12, compounded for 15-mil dry film thickness per coat. Provide inert-type noncorrosive compound free of asbestos fibers, sulfur components, and other deleterious impurities.

2.3 STANDARD HOLLOW METAL DOORS

- A. **General:** Provide doors of design indicated, not less than thickness indicated; fabricated with smooth surfaces, without visible joints or seams on exposed faces unless otherwise indicated. Comply with ANSI/SDI A250.8.
 - 1. Design: Flush panel.
 - 2. Core Construction: Manufacturer's standard kraft-paper honeycomb, polystyrene, polyurethane, polyisocyanurate, mineral-board, or vertical steel-stiffener core.
 - a. Thermal-Rated (Insulated) Doors: Where indicated, provide doors fabricated with thermal-resistance value (R-value) of not less than 12.3 degrees F x h x sq. ft./Btu when tested according to ASTM C 1363.
 - 1) Locations: Exterior doors and interior doors where indicated.
 - 3. Vertical Edges for Single-Acting Doors: Beveled edge.
 - a. Beveled Edge: 1/8 inch in 2 inches.
 - 4. Top and Bottom Edges: Closed with flush or inverted 0.042-inch- thick, end closures or channels of same material as face sheets.
 - 5. Tolerances: Comply with SDI 117, "Manufacturing Tolerances for Standard Steel Doors and Frames."

- B. **Exterior Doors:** Face sheets fabricated from metallic-coated steel sheet. Provide doors complying with requirements indicated below by referencing ANSI/SDI A250.8 for level and model and ANSI/SDI A250.4 for physical performance level:
 - 1. Level 4 and Physical Performance Level A (Maximum Duty), Model 2 (Seamless) (14 gauge face).
- C. **Hardware Reinforcement:** Fabricate according to ANSI/SDI A250.6 with reinforcing plates from same material as door face sheets.
- D. **Fabricate concealed stiffeners** and hardware reinforcement from either cold- or hot-rolled steel sheet.

2.4 STANDARD HOLLOW METAL FRAMES

- A. **General:** Comply with ANSI/SDI A250.8 and with details indicated for type and profile.
- B. **Interior Frames:** Fabricated from cold-rolled steel sheet unless metallic-coated sheet is indicated.
 - 1. Fabricate frames with mitered or coped corners.
 - 2. Fabricate frames as face welded unless otherwise indicated.
 - 3. Frames for Level 2 Steel Doors: 16 gauge (0.053-inch-) thick steel sheet.
 - 4. Frames for Wood Doors: 16 gauge (0.053-inch-) thick steel sheet.
 - 5. Frames for Borrowed Lights: 16 gauge (0.053-inch-) thick steel sheet.
- C. **Hardware Reinforcement:** Fabricate according to ANSI/SDI A250.6 with reinforcement plates from same material as frames.

2.5 FRAME ANCHORS

- A. **Jamb Anchors:**
 - 1. Masonry Type: Adjustable strap-and-stirrup or T-shaped anchors to suit frame size, not less than 19 gauge (0.042 inch) thick, with corrugated or perforated straps not less than 2 inches wide by 10 inches long; or wire anchors not less than 26 gauge (0.177 inch) thick.
 - 2. Stud-Wall Type: Designed to engage stud, welded to back of frames; not less than 19 gauge 0.042 inch thick.
 - 3. Postinstalled Expansion Type for In-Place Concrete or Masonry: Minimum 3/8-inch- diameter bolts with expansion shields or inserts. Provide pipe spacer from frame to wall, with throat reinforcement plate, welded to frame at each anchor location.
- B. **Floor Anchors:** Formed from same material as frames, not less than 19 gauge (0.042 inch) thick, and as follows:
 - 1. Monolithic Concrete Slabs: Clip-type anchors, with two holes to receive fasteners.

2.6 STOPS AND MOLDINGS

- A. **Moldings for Glazed Lites in Doors:** Minimum 21 gauge (0.032 inch) thick, fabricated from same material as door face sheet in which they are installed.
- B. **Fixed Frame Moldings:** Formed integral with hollow metal frames, a minimum of 5/8 inch high unless otherwise indicated.
- C. **Loose Stops for Glazed Lites in Frames:** Minimum 21 gauge (0.032 inch) thick, fabricated from same material as frames in which they are installed.

2.7 ACCESSORIES

- A. **Mullions and Transom Bars:** Join to adjacent members by welding or rigid mechanical anchors.
- B. **Ceiling Struts:** Minimum 1/4-inch-thick by 1-inch- wide steel.
- C. **Grout Guards:** Formed from same material as frames, not less than 0.016 inch thick.

2.8 FABRICATION

- A. **Fabricate hollow metal work** to be rigid and free of defects, warp, or buckle. Accurately form metal to required sizes and profiles, with minimum radius for thickness of metal. Where practical, fit and assemble units in manufacturer's plant. To ensure proper assembly at Project site, clearly identify work that cannot be permanently factory assembled before shipment.
- B. **Tolerances:** Fabricate hollow metal work to tolerances indicated in SDI 117.
- C. **Hollow Metal Doors:**
 - 1. **Exterior Doors:** Provide weep-hole openings in bottom of exterior doors to permit moisture to escape. Seal joints in top edges of doors against water penetration.
 - 2. **Glazed Lites:** Factory cut openings in doors.
- D. **Hollow Metal Frames:** Where frames are fabricated in sections due to shipping or handling limitations, provide alignment plates or angles at each joint, fabricated of same thickness metal as frames.
 - 1. **Welded Frames:** Weld flush face joints continuously; grind, fill, dress, and make smooth, flush, and invisible.
 - 2. **Sidelight Frames:** Provide closed tubular members with no visible face seams or joints, fabricated from same material as door frame. Fasten members at crossings and to jambs by butt welding.
 - 3. Provide countersunk, flat- or oval-head exposed screws and bolts for exposed fasteners unless otherwise indicated.
 - 4. **Grout Guards:** Weld guards to frame at back of hardware mortises in frames to be grouted.
 - 5. **Floor Anchors:** Weld anchors to bottom of jambs and mullions with at least four spot welds per anchor.
 - 6. **Jamb Anchors:** Provide number and spacing of anchors as follows:
 - a. **Stud-Wall Type:** Locate anchors not more than 18 inches from top and bottom of frame. Space anchors not more than 32 inches o.c. and as follows:
 - 1) Three anchors per jamb up to 60 inches high.
 - 2) Four anchors per jamb from 60 to 90 inches high.
 - 3) Five anchors per jamb from 90 to 96 inches high.
 - 4) Five anchors per jamb plus 1 additional anchor per jamb for each 24 inches or fraction thereof above 96 inches high.
 - 5) Two anchors per head for frames above 42 inches wide and mounted in metal-stud partitions.
 - b. **Compression Type:** Not less than two anchors in each jamb.
 - c. **Postinstalled Expansion Type:** Locate anchors not more than 6 inches from top and bottom of frame. Space anchors not more than 26 inches o.c.

7. Door Silencers: Except on weather-stripped doors, drill stops to receive door silencers as follows. Keep holes clear during construction.
 - a. Single-Door Frames: Drill stop in strike jamb to receive three door silencers.
 - b. Double-Door Frames: Drill stop in head jamb to receive two door silencers.
- E. **Fabricate concealed stiffeners**, edge channels, and hardware reinforcement from either cold- or hot-rolled steel sheet.
- F. **Hardware Preparation:** Factory prepare hollow metal work to receive templated mortised hardware; include cutouts, reinforcement, mortising, drilling, and tapping according to the Door Hardware Schedule and templates furnished as specified in Division 8 Section "Door Hardware."
 1. Locate hardware as indicated, or if not indicated, according to ANSI/SDI A250.8.
 2. Reinforce doors and frames to receive nontemplated, mortised and surface-mounted door hardware.
 3. Comply with applicable requirements in ANSI/SDI A250.6 and ANSI/DHI A115 Series specifications for preparation of hollow metal work for hardware.
 4. Coordinate locations of conduit and wiring boxes for electrical connections with Division 26 Sections.
 5. Provide auxiliary hinge reinforcement at all hinge locations on every frame.
- G. **Stops and Moldings:** Provide stops and moldings around glazed lites where indicated. Form corners of stops and moldings with butted or mitered hairline joints.
 1. Single Glazed Lites: Provide fixed stops and moldings welded on secure side of hollow metal work.
 2. Multiple Glazed Lites: Provide fixed and removable stops and moldings so that each glazed lite is capable of being removed independently.
 3. Provide fixed frame moldings on outside of exterior and on secure side of interior doors and frames.
 4. Provide loose stops and moldings on inside of hollow metal work.
 5. Coordinate rabbet width between fixed and removable stops with type of glazing and type of installation indicated.

2.9 STEEL FINISHES

- A. **Prime Finish:** Apply manufacturer's standard primer immediately after cleaning and pretreating.
 1. Shop Primer: Manufacturer's standard, fast-curing, lead- and chromate-free primer complying with ANSI/SDI A250.10 acceptance criteria; recommended by primer manufacturer for substrate; compatible with substrate and field-applied coatings despite prolonged exposure.

PART 3 - EXECUTION

3.1 EXAMINATION

- A. **Examine substrates**, areas, and conditions, with Installer present, for compliance with requirements for installation tolerances and other conditions affecting performance of the Work.
- B. **Examine roughing-in** for embedded and built-in anchors to verify actual locations before frame installation.

- C. **For the record, prepare written report**, endorsed by Installer, listing conditions detrimental to performance of the Work.
- D. **Proceed with installation** only after unsatisfactory conditions have been corrected.

3.2 PREPARATION

- A. **Remove welded-in shipping spreaders** installed at factory. Restore exposed finish by grinding, filling, and dressing, as required to make repaired area smooth, flush, and invisible on exposed faces.
- B. **Prior to installation**, adjust and securely brace welded hollow metal frames for squareness, alignment, twist, and plumbness to the following tolerances:
 - 1. Squareness: Plus or minus 1/16 inch, measured at door rabbet on a line 90 degrees from jamb perpendicular to frame head.
 - 2. Alignment: Plus or minus 1/16 inch, measured at jambs on a horizontal line parallel to plane of wall.
 - 3. Twist: Plus or minus 1/16 inch, measured at opposite face corners of jambs on parallel lines, and perpendicular to plane of wall.
 - 4. Plumbness: Plus or minus 1/16 inch, measured at jambs on a perpendicular line from head to floor.
- C. **Drill and tap doors and frames** to receive nontemplated, mortised, and surface-mounted door hardware.

3.3 INSTALLATION

- A. **General:** Install hollow metal work plumb, rigid, properly aligned, and securely fastened in place; comply with Drawings and manufacturer's written instructions.
- B. **Hollow Metal Frames:** Install hollow metal frames of size and profile indicated. Comply with ANSI/SDI A250.11.
 - 1. Set frames accurately in position, plumbed, aligned, and braced securely until permanent anchors are set. After wall construction is complete, remove temporary braces, leaving surfaces smooth and undamaged.
 - a. At fire-protection-rated openings, install frames according to NFPA 80.
 - b. Where frames are fabricated in sections because of shipping or handling limitations, field splice at approved locations by welding face joint continuously; grind, fill, dress, and make splice smooth, flush, and invisible on exposed faces.
 - c. Install frames with removable glazing stops located on secure side of opening.
 - d. Install door silencers in frames before grouting.
 - e. Remove temporary braces necessary for installation only after frames have been properly set and secured.
 - f. Check plumbness, squareness, and twist of frames as walls are constructed. Shim as necessary to comply with installation tolerances.
 - g. Field apply bituminous coating to backs of frames that are filled with grout containing antifreezing agents.
 - 2. Floor Anchors: Provide floor anchors for each jamb and mullion that extends to floor, and secure with postinstalled expansion anchors.
 - a. Floor anchors may be set with powder-actuated fasteners instead of postinstalled expansion anchors if so indicated and approved on Shop Drawings.
 - 3. Metal-Stud Partitions: Solidly pack mineral-fiber insulation behind frames.
 - 4. Masonry Walls: Coordinate installation of frames to allow for solidly filling space between frames and masonry with grout.

5. **Concrete Walls:** Solidly fill space between frames and concrete with grout. Take precautions, including bracing frames, to ensure that frames are not deformed or damaged by grout forces.
 6. **In-Place Concrete or Masonry Construction:** Secure frames in place with postinstalled expansion anchors. Countersink anchors, and fill and make smooth, flush, and invisible on exposed faces.
 7. **In-Place Gypsum Board Partitions:** Secure frames in place with postinstalled expansion anchors through floor anchors at each jamb. Countersink anchors, and fill and make smooth, flush, and invisible on exposed faces.
 8. **Ceiling Struts:** Extend struts vertically from top of frame at each jamb to overhead structural supports or substrates above frame unless frame is anchored to masonry or to other structural support at each jamb. Bend top of struts to provide flush contact for securing to supporting construction. Provide adjustable wedged or bolted anchorage to frame jamb members.
 9. **Installation Tolerances:** Adjust hollow metal door frames for squareness, alignment, twist, and plumb to the following tolerances:
 - a. **Squareness:** Plus or minus 1/16 inch, measured at door rabbet on a line 90 degrees from jamb perpendicular to frame head.
 - b. **Alignment:** Plus or minus 1/16 inch, measured at jambs on a horizontal line parallel to plane of wall.
 - c. **Twist:** Plus or minus 1/16 inch, measured at opposite face corners of jambs on parallel lines, and perpendicular to plane of wall.
 - d. **Plumbness:** Plus or minus 1/16 inch, measured at jambs at floor.
- C. **Hollow Metal Doors:** Fit hollow metal doors accurately in frames, within clearances specified below. Shim as necessary.
1. **Non-Fire-Rated Standard Steel Doors:**
 - a. **Jambs and Head:** 1/8 inch plus or minus 1/16 inch.
 - b. **Between Edges of Pairs of Doors:** 1/8 inch plus or minus 1/16 inch.
 - c. **Between Bottom of Door and Top of Threshold:** Maximum 3/8 inch.
 - d. **Between Bottom of Door and Top of Finish Floor (No Threshold):** Maximum 3/4 inch.
- D. **Glazing:** Comply with installation requirements in Division 8 Section "Glazing" and with hollow metal manufacturer's written instructions.
1. Secure stops with countersunk flat- or oval-head machine screws spaced uniformly not more than 9 inches o.c. and not more than 2 inches o.c. from each corner.

3.4 ADJUSTING AND CLEANING

- A. **Final Adjustments:** Check and readjust operating hardware items immediately before final inspection. Leave work in complete and proper operating condition. Remove and replace defective work, including hollow metal work that is warped, bowed, or otherwise unacceptable.
- B. **Remove grout** and other bonding material from hollow metal work immediately after installation.
- C. **Prime-Coat Touchup:** Immediately after erection, sand smooth rusted or damaged areas of prime coat and apply touchup of compatible air-drying, rust-inhibitive primer.
- D. **Metallic-Coated Surfaces:** Clean abraded areas and repair with galvanizing repair paint according to manufacturer's written instructions.

END OF SECTION

SECTION 08 1416
FLUSH WOOD DOORS

PART 1 - GENERAL

1.1 RELATED DOCUMENTS

- A. Drawings and general provisions of the Contract, including General and Supplementary Conditions and Division 1 Specification Sections, apply to this Section.

1.2 SUMMARY

- A. This **Section includes** the following:
1. Solid-core doors with wood-veneer faces.
 2. Factory finishing flush wood doors.
- B. **Related Sections** include the following:
1. Section 08 1113 "**Hollow Metal Doors and Frames**" for conventional and lead lined frames.
 2. Section 08 7100 "**Door Hardware**" for hardware on standard swing doors.
 3. Section 08 8000 "**Glazing**" for glass view panels in flush wood doors.

1.3 SUBMITTALS

- A. **Product Data:** For each type of door. Include details of core and edge construction, louvers, and trim for openings. Include factory-finishing specifications.
- B. **Shop Drawings:** Indicate location, size, and hand of each door; elevation of each kind of door; construction details not covered in Product Data; location and extent of hardware blocking; and other pertinent data.
1. Dimensions and locations of mortises and holes for hardware.
 2. Dimensions and locations of cutouts.
 3. Undercuts.
 4. Requirements for veneer matching.
 5. Doors to be factory finished and finish requirements.
 6. Fire ratings for fire doors.
- C. **Samples for Selection:** Color charts consisting of actual materials in small sections for the following:
1. Faces of Factory-Finished Doors: Show the full range of colors available for stained finishes.

1.4 QUALITY ASSURANCE

- A. **Source Limitations:** Obtain flush wood doors through one source from a single manufacturer.
- B. **Manufacturer Qualifications:** A qualified manufacturer that is a certified participant in AWI's Quality Certification Program.
- C. **Quality Standard:** Comply with AWI/AWMAC/WI "Architectural Woodwork Standards, Edition 2."
1. Provide AWI Quality Certification Labels or an AWI letter of licensing for Project indicating that doors comply with requirements of grades specified.

- D. **Fire-Rated Wood Doors:** Doors complying with NFPA 80 that are listed and labeled by a testing and inspecting agency acceptable to authorities having jurisdiction, for fire ratings indicated, based on testing according to NFPA 252.
1. Test Pressure: Test at atmospheric pressure.
 2. Temperature-Rise Rating: At exit enclosures, provide doors that have a temperature-rise rating of 450 degrees F maximum in 30 minutes of fire exposure.

1.5 DELIVERY, STORAGE, AND HANDLING

- A. **Comply** with requirements of referenced standard and manufacturer's written instructions.
- B. **Package doors individually** in plastic bags or cardboard cartons.
- C. **Mark each door on top and bottom rail** with opening number used on Shop Drawings. Do not mark tops of doors where visible from above.

1.6 PROJECT CONDITIONS

- A. **Environmental Limitations:** Do not deliver or install doors until building is enclosed, wet work is complete, and HVAC system is operating and will maintain temperature and relative humidity at occupancy levels during the remainder of the construction period.

1.7 WARRANTY

- A. **Special Warranty:** Manufacturer's standard form, signed by manufacturer, Installer, and Contractor, in which manufacturer agrees to repair or replace doors that are defective in materials or workmanship, have warped (bow, cup, or twist) more than 1/4 inch in a 42-by-84-inch section, or show telegraphing of core construction in face veneers exceeding 0.01 inch in a 3-inch span.
1. Warranty shall be in effect during the following period of time from date of Substantial Completion:
 - a. Solid-Core Interior Doors: Life of installation.

PART 2 - PRODUCTS

2.1 MANUFACTURERS

- A. **Basis of Design:** Contract Documents are based on products specified below to establish a standard of quality. Other available manufacturers may be considered, provided deviations are minor and design concept as expressed in the Contract Documents is not changed, as judged by the Architect.
1. Manufacturer: VT Industries, Inc.
 2. Product: Artistry.
- B. **Available Manufacturers:** Subject to compliance with requirements, manufacturers offering products that may be incorporated into the Work include, but are not limited to, the following:
1. Eggers Industries; Architectural Door Division.
 2. Assa Abloy; Graham/Maiman.
 3. Oshkosh Door Company.
 4. VT Industries Inc.
 5. Masonite Architectural; Marshfield-Algoma.

2.2 DOOR CONSTRUCTION, GENERAL

- A. **Low-Emitting Materials:** Fabricate doors with adhesives and composite wood products that do not contain urea formaldehyde.
- C. **Doors for Transparent Finish:**
1. Grade: Premium, with Grade AA faces.
 2. Species and Cut: Match existing species and cut (plain-sliced white birch).
 3. Match between Veneer Leaves: Book match.
 4. Assembly of Veneer Leaves on Door Faces: Running match.
 5. Pair and Set Match: Provide for doors hung in same opening or separated only by mullions.
 6. Room Match: Provide door faces of compatible color and grain within each separate room or area of building.
 7. Stiles: Same species as faces.

2.3 SOLID-CORE DOORS

- A. **Particleboard Cores:** Comply with the following requirements:
1. Particleboard: ANSI A208.1, Grade LD-2.
- B. **Interior Veneer-Faced Doors:**
1. Core: Particleboard.
 2. Construction: Five plies with stiles and rails bonded to core; entire unit abrasive planed before veneering.
- C. **Fire-Rated Doors:**
1. Construction: Construction and core specified above for type of face indicated or manufacturer's standard mineral-core construction as needed to provide fire rating indicated. Comply with NFPA 80 for fire-rated doors
 2. Blocking: For mineral-core doors, provide composite blocking with improved screw-holding capability approved for use in doors of fire ratings indicated as follows:
 - a. 5-inch top-rail blocking.
 - b. 5-inch bottom-rail blocking, in doors indicated to have protection plates.
 - c. 5-inch midrail blocking, in doors indicated to have armor plates.
 - d. 5-inch midrail blocking, in doors indicated to have exit devices.
 3. Edge Construction: At hinge stiles, provide manufacturer's standard laminated-edge construction with improved screw-holding capability and split resistance and with outer stile matching face veneer.
 4. Pairs: Provide fire-rated pairs with fire-retardant stiles matching face veneer that are labeled and listed for kinds of applications indicated without formed-steel edges and astragals. Provide stiles with concealed intumescent seals.

2.4 LIGHT FRAMES

- A. **Wood Beads for Light Openings in Wood Doors:** Provide manufacturer's standard wood beads unless otherwise indicated.
1. Wood Species: Same species as door faces.
 2. Profile: Flush rectangular beads.
 3. At wood-core doors with 20-minute fire-protection ratings, provide wood beads and metal glazing clips approved for such use.
- B. **Metal Frames for Light Openings in Fire Rated Doors (Greater than 20 Minutes):** Manufacturer's standard frame formed of 18 gauge, cold-rolled steel sheet, factory primed; match fire rating indicated for doors.

2.5 FABRICATION

- A. **Fabricate doors** in sizes indicated for Project-site fitting.
 - 1. Comply with clearance requirements of referenced quality standard for fitting.
- B. **Openings:** Cut and trim openings through doors to comply with applicable requirements of referenced standards for kind(s) of door(s) required.
 - 1. Light Openings: Trim openings with moldings of material and profile indicated.

2.6 FACTORY FINISHING

- A. **General:** Comply with AWI's "Architectural Woodwork Quality Standards Illustrated" for factory finishing.
- B. **Finish doors at factory.**
- C. **Transparent Finish:**
 - 1. Grade: Premium.
 - 2. Finish: AWS System 11 - catalyzed polyurethane.
 - 3. Staining: Match existing (VT Clear Maple CL07 or as approved by Architect).
 - 4. Effect: Open-grain finish.
 - 5. Sheen: Semigloss.

PART 3 - EXECUTION

3.1 EXAMINATION

- A. **Examine doors** and installed doorframes before hanging doors.
 - 1. Verify that frames comply with indicated requirements for type, size, location, and swing characteristics and have been installed with level heads and plumb jambs.
 - 2. Reject doors with defects.
- B. **Proceed with installation** only after unsatisfactory conditions have been corrected.

3.2 INSTALLATION

- A. **Hardware:** For installation, see Division 8 Section "Door Hardware."
- B. **Manufacturer's Written Instructions:** Install doors to comply with manufacturer's written instructions, referenced quality standard, and as indicated.
- C. **Job-Fitted Doors:** Align and fit doors in frames with uniform clearances and bevels as indicated below; do not trim stiles and rails in excess of limits set by manufacturer or permitted for fire-rated doors. Machine doors for hardware. Seal cut surfaces after fitting and machining.
 - 1. Clearances: Provide 1/8 inch at heads, jambs, and between pairs of doors. Provide 1/8 inch from bottom of door to top of decorative floor finish or covering. Where threshold is shown or scheduled, provide 1/4 inch from bottom of door to top of threshold.
 - a. Comply with NFPA 80 for fire-rated doors.
 - 2. Bevel non-fire-rated doors 1/8 inch in 2 inches (3-1/2 degrees) at lock and hinge edges.
 - 3. Bevel fire-rated doors 1/8 inch in 2 inches (3-1/2 degrees) at lock edge; trim stiles and rails only to extent permitted by labeling agency.

- D. **Factory-Finished Doors:** Restore finish before installation if fitting or machining is required at Project site.

3.3 ADJUSTING

- A. **Operation:** Rehang or replace doors that do not swing or operate freely.
- B. **Finished Doors:** Replace doors that are damaged or do not comply with requirements. Doors may be repaired or refinished if work complies with requirements and shows no evidence of repair or refinishing.

END OF SECTION

THIS PAGE LEFT BLANK INTENTIONALLY

SECTION 08 3100

ACCESS DOORS AND FRAMES

PART 1 - GENERAL

1.1 RELATED DOCUMENTS

- A. Drawing and general provisions of the Contract, including General and Supplementary Conditions and Division 1 Specification Sections, apply to this Section.

1.2 SUMMARY

- A. This **Section includes** the following:
 - 1. Wall access doors and frames.
 - 2. Ceiling access doors and frames.
- B. **Related Sections** include the following:
 - 1. Section 08 7100 "**Door Hardware**" for mortise or rim cylinder locks and master keying.
 - 2. Section 23 3300 "**Duct Accessories**" for heating and air-conditioning duct access doors.

1.3 SUBMITTALS

- A. **Product Data:** For each type of door and frame indicated. Include construction details relative to materials, individual components and profiles, finishes, and fire ratings (if required) for access doors and frames.
- B. **Shop Drawings:** Show fabrication and installation details of customized doors and frames. Include plans, elevations, sections, details, and attachments to other Work.
- C. **Schedule:** Provide complete door and frame schedule, including types, general locations, sizes, construction details, latching or locking provisions, and other data pertinent to installation.
- D. **Coordination Drawings:** Reflected ceiling plans drawn to scale and coordinating penetrations and ceiling-mounted items with concealed framing, suspension systems, piping, ductwork, and other construction. Show the following:
 - 1. Method of attaching door frames to surrounding construction.
 - 2. Ceiling-mounted items including access doors and frames, lighting fixtures, diffusers, grilles, speakers, sprinklers, and special trim.

1.4 QUALITY ASSURANCE

- A. **Source Limitations:** Obtain doors and frames through one source from a single manufacturer.
- B. **Size Variations:** Obtain Architect's acceptance of manufacturer's standard-size units, which may vary slightly from sizes indicated.

1.5 COORDINATION

- A. **Verification:** Determine specific locations and sizes for access doors needed to gain access to concealed equipment, and indicate on schedule specified in "Submittals" Article.

1.6 ALLOWANCES

- A. **Beyond the access doors indicated on the Drawings** that are called out with sizes and locations, include five (5) 24 x 24 inches flush panel access doors (gypsum wall and ceiling) and five (5) 24 x 24 inches flush two hour fire rated panel access doors (gypsum wall and ceiling) to be located as directed by the Architect. Cost to include installation and General Contractor's mark up. Provide credit to Owner for unused doors.

PART 2 - PRODUCTS

2.1 MANUFACTURERS

- A. **Available Manufacturers:** Subject to compliance with requirements of Contract Documents, manufacturers offering products that may be incorporated into the Work include, but are not limited to, the following:
 1. Babcock-Davis.
 2. Bilco.
 3. J. L. Industries, Inc, a part of the Activar Construction Products Group.
 4. Larsen's Manufacturing Company, a member of Morris Group International.
 5. Milcor/Hart & Cooley Inc, a trademark of Johnson Controls, Inc.
 6. Nystrom.

2.2 MATERIALS

- A. **Steel Plates, Shapes, and Bars:** ASTM A 36/A 36M.
- B. **Electrolytic Zinc-Coated Steel Sheet:** ASTM A 591/A 591M, Commercial Steel (CS), with Class C coating and phosphate treatment to prepare surface for painting; with minimum thickness indicated representing specified nominal thickness according to ASTM A 568/A 568M for uncoated base metal.
- C. **Drywall Beads:** Edge trim formed from 22 gauge zinc-coated steel sheet formed to receive joint compound and in size to suit thickness of gypsum board.

2.3 PAINT

- A. **Shop Primer for Ferrous Metal:** Fast-curing, lead- and chromate-free, universal modified-alkyd primer complying with performance requirements in FS TT-P-664; selected for good resistance to normal atmospheric corrosion, compatibility with finish paint systems indicated, and capability to provide a sound foundation for field-applied topcoats despite prolonged exposure.

2.4 ACCESS DOORS AND FRAMES

- A. **Flush, Insulated, Fire-Rated Access Doors and Trimless Frames:** Fabricated from steel sheet.
1. Locations: Gypsum board wall and ceiling surfaces. Fire resistance rating to be 1 hour minimum rating or as scheduled on the drawings.
 2. Door: Flush panel with a core of mineral-fiber insulation enclosed in sheet metal with a minimum thickness of 20 gauge.
 3. Frame: Minimum 16 gauge sheet metal with 1 inch wide, surface-mounted trim.
 4. Hinges: Continuous piano hinge.
 5. Automatic Closer: Spring type.
 6. Latch: Self-latching bolt operated by knurled knob with interior release.
 7. Lock: Key-operated cylinder lock with interior release.
 8. Size: As indicated on the Drawings, or for determining the allowance provide a 24 x 24 inches.
- B. **Flush Access Doors and Frames with Exposed Trim:** Fabricated from steel sheet.
1. Locations: Masonry, concrete and ceramic-tile wall surfaces.
 2. Door: Minimum 16 gauge sheet metal, set flush with exposed face flange of frame.
 3. Frame: Minimum 16 gauge sheet metal with 1 inch wide, surface-mounted trim.
 4. Hinges: Continuous piano hinge.
 5. Latch: Screwdriver-operated cam latch.
 6. Lock: Key-operated cylinder lock.
 7. Size: As indicated on the Drawings, or for determining the allowance provide a 24 x 24 inches.
- C. **Flush Access Doors and Trimless Frames:** Fabricated from steel sheet.
1. Locations: Gypsum board wall and ceiling surfaces.
 2. Door: Minimum 16 gauge sheet metal, set flush with surrounding finish surfaces.
 3. Frame: Minimum 16 gauge sheet metal with drywall bead.
 4. Hinges: Continuous piano hinge.
 5. Latch: Screwdriver-operated cam latch.
 6. Lock: Key-operated cylinder lock.
 7. Size: As indicated on the Drawings, or for determining the allowance provide a 24 x 24 inches.
- D. **Weather Resistant Exterior Flush Access Doors and Frames with Exposed Trim:** Fabricated from steel sheet and extruded aluminum.
1. Locations: Roof parapet and where shown on Drawings.
 2. Door: Minimum 22 gauge galvanized sheet steel, set flush with exposed face flange of frame, insulated with R13 value foam.
 3. Frame: Minimum .080 inch 6063-T5 extruded aluminum. Furnish with drip cap.
 4. Gasketing: Extruded santoprene.
 5. Hinge: Continuous stainless steel piano hinge.
 6. Latch: Screwdriver-operated cam latch.
 7. Lock: Key-operated cylinder lock.
 8. Size: 12 inches square or as indicated on Drawings.

2.5 FABRICATION

- A. **General:** Provide access door assemblies manufactured as integral units ready for installation.

- B. **Metal Surfaces:** For metal surfaces exposed to view in the completed Work, provide materials with smooth, flat surfaces without blemishes. Do not use materials with exposed pitting, seam marks, roller marks, rolled trade names, or roughness.
- C. **Steel Doors and Frames:** Grind exposed welds smooth and flush with adjacent surfaces. Furnish attachment devices and fasteners of type required to secure access panels to types of supports indicated.
 - 1. Exposed Flanges: Nominal 1 to 1-1/2 inches wide around perimeter of frame.
 - 2. For trimless frames with drywall bead for installation in gypsum board assembly, provide edge trim for gypsum board securely attached to perimeter of frames.
 - 3. Provide mounting holes in frames to attach frames to framing in drywall construction and to attach masonry anchors in masonry construction. Furnish adjustable metal masonry anchors.
- D. **Latching Mechanisms:** Furnish number required to hold doors in flush, smooth plane when closed.
 - 1. For cylinder lock, furnish two keys per lock and key all locks alike.

2.6 FINISHES, GENERAL

- A. **Comply with NAAMM's "Metal Finishes Manual for Architectural and Metal Products"** for recommendations for applying and designating finishes.
- B. **Finish metal fabrications** after assembly.

2.7 METALLIC-COATED STEEL FINISHES

- A. **Galvanizing of Steel Shapes and Plates:** Hot-dip galvanize items indicated to comply with applicable standard listed below:
 - 1. ASTM A 153/A 153M, for galvanizing steel and iron hardware.
- B. **Surface Preparation:** Clean surfaces with nonpetroleum solvent so surfaces are free of oil and other contaminants. For galvanized surfaces, apply, after cleaning, a conversion coating suited to the organic coating to be applied over it. For metallic-coated surfaces, clean welds, mechanical connections, and abraded areas, and apply galvanizing repair paint specified below to comply with ASTM A 780.
 - 1. Galvanizing Repair Paint: High-zinc-dust-content paint for regalvanizing welds in steel, complying with SSPC-Paint 20.
- C. **Factory Priming for Field-Painted Finish:** Apply shop primer immediately after cleaning and pretreating.

2.8 STEEL FINISHES

- A. **Surface Preparation:** Prepare uncoated ferrous-metal surfaces to comply with minimum requirements indicated below for SSPC surface-preparation specifications and environmental exposure conditions of installed metal fabrications:
 - 1. Exteriors (SSPC Zone 1B): SSPC-SP 6/NACE No. 3, "Commercial Blast Cleaning."
 - 2. Interiors (SSPC Zone 1A): SSPC-SP 3, "Power Tool Cleaning."
- B. **Apply shop primer** to uncoated surfaces of metal fabrications. Comply with SSPC-PA 1, "Paint Application Specification No. 1," for shop painting.

PART 3 - EXECUTION

3.1 PREPARATION

- A. **Advise installers** of other work about specific requirements relating to access door and floor door installation, including sizes of openings to receive access door and frame, as well as locations of supports, inserts, and anchoring devices.

3.2 INSTALLATION

- A. **Comply with manufacturer's written instructions** for installing access doors and frames and floor doors and frames.
- B. **Set frames accurately** in position and attach securely to supports with plane of face panels aligned with adjacent finish surfaces.
- C. **Install access doors** with trimless frames and floor doors flush with adjacent finish surfaces or recessed to receive finish material.

3.3 ADJUSTING AND CLEANING

- A. **Adjust doors and hardware** after installation for proper operation.
- B. **Remove and replace doors and frames** that are warped, bowed, or otherwise damaged.

END OF SECTION

THIS PAGE LEFT BLANK INTENTIONALLY

SECTION 08 7100

DOOR HARDWARE

PART 1 - GENERAL

1.1 RELATED DOCUMENTS

- A. Drawings and general provisions of the Contract, including General and Supplementary Conditions and Division 1 Specification Sections, apply to this Section.

1.2 SUMMARY

- A. This Section includes commercial door hardware for the following:
 - 1. Swinging doors.
 - 2. Other doors to the extent indicated.
- B. Door hardware includes, but is not necessarily limited to, the following:
 - 1. Mechanical door hardware.
 - 2. Electromechanical door hardware.
 - 3. Automatic operators.
 - 4. Cylinders specified for doors in other sections.
- C. Related Sections:
 - 1. Division 08 Section "Hollow Metal Doors and Frames".
 - 2. Division 08 Section "Flush Wood Doors".
 - 3. Division 08 Section "Automatic Door Operators".
- D. Codes and References: Comply with the version year adopted by the Authority Having Jurisdiction.
 - 1. ANSI A117.1 - Accessible and Usable Buildings and Facilities.
 - 2. ICC/IBC - International Building Code.
 - 3. NFPA 70 - National Electrical Code.
 - 4. NFPA 80 - Fire Doors and Windows.
 - 5. NFPA 101 - Life Safety Code.
 - 6. NFPA 105 - Installation of Smoke Door Assemblies.
 - 7. UL/ULC and CSA C22.2 - Standards for Automatic Door Operators Used on Fire and Smoke Barrier Doors and Systems of Doors.
 - 8. State Building Codes, Local Amendments.
- E. Standards: All hardware specified herein shall comply with the following industry standards as applicable. Any undated reference to a standard shall be interpreted as referring to the latest edition of that standard:
 - 1. ANSI/BHMA Certified Product Standards - A156 Series.

2. UL10C - Positive Pressure Fire Tests of Door Assemblies.
3. ANSI/UL 294 - Access Control System Units.
4. UL 305 - Panic Hardware.
5. ANSI/UL 437- Key Locks.

1.3 SUBMITTALS

- A. Product Data: Manufacturer's product data sheets including installation details, material descriptions, dimensions of individual components and profiles, operational descriptions and finishes.
- B. Door Hardware Schedule: Prepared by or under the supervision of supplier, detailing fabrication and assembly of door hardware, as well as procedures and diagrams. Coordinate the final Door Hardware Schedule with doors, frames, and related work to ensure proper size, thickness, hand, function, and finish of door hardware.
 1. Format: Comply with scheduling sequence and vertical format in DHI's "Sequence and Format for the Hardware Schedule."
 2. Organization: Organize the Door Hardware Schedule into door hardware sets indicating complete designations of every item required for each door or opening. Organize door hardware sets in same order as in the Door Hardware Sets at the end of Part 3. Submittals that do not follow the same format and order as the Door Hardware Sets will be rejected and subject to resubmission.
 3. Content: Include the following information:
 - a. Type, style, function, size, label, hand, and finish of each door hardware item.
 - b. Manufacturer of each item.
 - c. Fastenings and other pertinent information.
 - d. Location of door hardware set, cross-referenced to Drawings, both on floor plans and in door and frame schedule.
 - e. Explanation of abbreviations, symbols, and codes contained in schedule.
 - f. Mounting locations for door hardware.
 - g. Door and frame sizes and materials.
 - h. Warranty information for each product.
 4. Submittal Sequence: Submit the final Door Hardware Schedule at earliest possible date, particularly where approval of the Door Hardware Schedule must precede fabrication of other work that is critical in the Project construction schedule. Include Product Data, Samples, Shop Drawings of other work affected by door hardware, and other information essential to the coordinated review of the Door Hardware Schedule.
- C. Shop Drawings: Details of electrified access control hardware indicating the following:
 1. Wiring Diagrams: Upon receipt of approved schedules, submit detailed system wiring diagrams for power, signaling, monitoring, communication, and control of the access control system electrified hardware. Differentiate between manufacturer-installed and field-installed wiring. Include the following:

- a. Elevation diagram of each unique access controlled opening showing location and interconnection of major system components with respect to their placement in the respective door openings.
 - b. Complete (risers, point-to-point) access control system block wiring diagrams.
 - c. Wiring instructions for each electronic component scheduled herein.
- 2. Electrical Coordination: Coordinate with related sections the voltages and wiring details required at electrically controlled and operated hardware openings.
- D. Keying Schedule: After a keying meeting with the owner has taken place prepare a separate keying schedule detailing final instructions. Submit the keying schedule in electronic format. Include keying system explanation, door numbers, key set symbols, hardware set numbers and special instructions. Owner must approve submitted keying schedule prior to the ordering of permanent cylinders/cores.
- E. Informational Submittals:
 - 1. Product Test Reports: Indicating compliance with cycle testing requirements, based on evaluation of comprehensive tests performed by manufacturer and witnessed by a qualified independent testing agency.
- F. Operating and Maintenance Manuals: Provide manufacturers operating and maintenance manuals for each item comprising the complete door hardware installation in quantity as required in Division 01, Closeout Procedures.

1.4 QUALITY ASSURANCE

- A. Manufacturers Qualifications: Engage qualified manufacturers with a minimum 5 years of documented experience in producing hardware and equipment similar to that indicated for this Project and that have a proven record of successful in-service performance.
- B. Certified Products: Where specified, products must maintain a current listing in the Builders Hardware Manufacturers Association (BHMA) Certified Products Directory (CPD).
- C. Installer Qualifications: A minimum 3 years documented experience installing both standard and electrified door hardware similar in material, design, and extent to that indicated for this Project and whose work has resulted in construction with a record of successful in-service performance.
- D. Door Hardware Supplier Qualifications: Experienced commercial door hardware distributors with a minimum 5 years documented experience supplying both mechanical and electromechanical hardware installations comparable in material, design, and extent to that indicated for this Project. Supplier recognized as a factory direct distributor by the manufacturers of the primary materials with a warehousing facility in Project's vicinity. Supplier to have on staff a certified Architectural Hardware Consultant (AHC) available during the course of the Work to consult with Contractor, Architect, and Owner concerning both standard and electromechanical door hardware and keying.
- E. Automatic Operator Supplier Qualifications: Power operator products and accessories are required to be supplied and installed through the Norton Preferred Installer (NPI) program. Suppliers are to be factory trained, certified, and a direct purchaser of the specified power operators and be responsible for the installation and maintenance of the units and accessories indicated for the Project.

- F. Source Limitations: Obtain each type and variety of door hardware specified in this section from a single source unless otherwise indicated.
 - 1. Electrified modifications or enhancements made to a source manufacturer's product line by a secondary or third party source will not be accepted.
 - 2. Provide electromechanical door hardware from the same manufacturer as mechanical door hardware, unless otherwise indicated.
- G. Each unit to bear third party permanent label demonstrating compliance with the referenced standards.
- H. Keying Conference: Conduct conference to comply with requirements in Division 01 Section "Project Meetings." Keying conference to incorporate the following criteria into the final keying schedule document:
 - 1. Function of building, purpose of each area and degree of security required.
 - 2. Plans for existing and future key system expansion.
 - 3. Requirements for key control storage and software.
 - 4. Installation of permanent keys, cylinder cores and software.
 - 5. Address and requirements for delivery of keys.
- I. Pre-Submittal Conference: Conduct coordination conference in compliance with requirements in Division 01 Section "Project Meetings" with attendance by representatives of Supplier(s), Installer(s), and Contractor(s) to review proper methods and the procedures for receiving, handling, and installing door hardware.
 - 1. Prior to installation of door hardware, conduct a project specific training meeting to instruct the installing contractors' personnel on the proper installation and adjustment of their respective products. Product training to be attended by installers of door hardware (including electromechanical hardware) for aluminum, hollow metal and wood doors. Training will include the use of installation manuals, hardware schedules, templates and physical product samples as required.
 - 2. Inspect and discuss electrical roughing-in, power supply connections, and other preparatory work performed by other trades.
 - 3. Review sequence of operation narratives for each unique access controlled opening.
 - 4. Review and finalize construction schedule and verify availability of materials.
 - 5. Review the required inspecting, testing, commissioning, and demonstration procedures
- J. At completion of installation, provide written documentation that components were applied to manufacturer's instructions and recommendations and according to approved schedule.

1.5 DELIVERY, STORAGE, AND HANDLING

- A. Inventory door hardware on receipt and provide secure lock-up and shelving for door hardware delivered to Project site. Do not store electronic access control hardware, software or accessories at Project site without prior authorization.
- B. Tag each item or package separately with identification related to the final Door Hardware Schedule, and include basic installation instructions with each item or package.

- C. Deliver, as applicable, permanent keys, cylinders, cores, access control credentials, software and related accessories directly to Owner via registered mail or overnight package service. Instructions for delivery to the Owner shall be established at the "Keying Conference".

1.6 COORDINATION

- A. Templates: Obtain and distribute to the parties involved templates for doors, frames, and other work specified to be factory prepared for installing standard and electrified hardware. Check Shop Drawings of other work to confirm that adequate provisions are made for locating and installing hardware to comply with indicated requirements.
- B. Door and Frame Preparation: Doors and corresponding frames are to be prepared, reinforced and pre-wired (if applicable) to receive the installation of the specified electrified, monitoring, signaling and access control system hardware without additional in-field modifications.

1.7 WARRANTY

- A. General Warranty: Reference Division 01, General Requirements. Special warranties specified in this Article shall not deprive Owner of other rights Owner may have under other provisions of the Contract Documents and shall be in addition to, and run concurrent with, other warranties made by Contractor under requirements of the Contract Documents.
- B. Warranty Period: Written warranty, executed by manufacturer(s), agreeing to repair or replace components of standard and electrified door hardware that fails in materials or workmanship within specified warranty period after final acceptance by the Owner. Failures include, but are not limited to, the following:
 - 1. Structural failures including excessive deflection, cracking, or breakage.
 - 2. Faulty operation of the hardware.
 - 3. Deterioration of metals, metal finishes, and other materials beyond normal weathering.
 - 4. Electrical component defects and failures within the systems operation.
- C. Standard Warranty Period: One year from date of Substantial Completion, unless otherwise indicated.
- D. Special Warranty Periods:
 - 1. Ten years for mortise locks and latches.
 - 2. Twenty five years for manual overhead door closer bodies.
 - 3. Two years for electromechanical door hardware, unless noted otherwise.

1.8 MAINTENANCE SERVICE

- A. Maintenance Tools and Instructions: Furnish a complete set of specialized tools and maintenance instructions as needed for Owner's continued adjustment, maintenance, and removal and replacement of door hardware.

PART 2 - PRODUCTS

2.1 SCHEDULED DOOR HARDWARE

- A. General: Provide door hardware for each door to comply with requirements in Door Hardware Sets and each referenced section that products are to be supplied under.
- B. Designations: Requirements for quantity, item, size, finish or color, grade, function, and other distinctive qualities of each type of door hardware are indicated in the Door Hardware Sets at the end of Part 3. Products are identified by using door hardware designations, as follows:
 - 1. Named Manufacturer's Products: Product designation and manufacturer are listed for each door hardware type required for the purpose of establishing requirements. Manufacturers' names are abbreviated in the Door Hardware Schedule.
- C. Substitutions: Requests for substitution and product approval for inclusive mechanical and electromechanical door hardware in compliance with the specifications must be submitted in writing and in accordance with the procedures and time frames outlined in Division 01, Substitution Procedures. Approval of requests is at the discretion of the architect, owner, and their designated consultants.

2.2 HANGING DEVICES

- A. Hinges: ANSI/BHMA A156.1 certified butt hinges with number of hinge knuckles and other options as specified in the Door Hardware Sets.
 - 1. Quantity: Provide the following hinge quantity:
 - a. Two Hinges: For doors with heights up to 60 inches.
 - b. Three Hinges: For doors with heights 61 to 90 inches.
 - c. Four Hinges: For doors with heights 91 to 120 inches.
 - d. For doors with heights more than 120 inches, provide 4 hinges, plus 1 hinge for every 30 inches of door height greater than 120 inches.
 - 2. Hinge Size: Provide the following, unless otherwise indicated, with hinge widths sized for door thickness and clearances required:
 - a. Widths up to 3'0": 4-1/2" standard or heavy weight as specified.
 - b. Sizes from 3'1" to 4'0": 5" standard or heavy weight as specified.
 - 3. Hinge Weight and Base Material: Unless otherwise indicated, provide the following:
 - a. Exterior Doors: Heavy weight, non-ferrous, ball bearing or oil impregnated bearing hinges unless Hardware Sets indicate standard weight.
 - b. Interior Doors: Standard weight, steel, ball bearing or oil impregnated bearing hinges unless Hardware Sets indicate heavy weight.
 - 4. Hinge Options: Comply with the following:

- a. Non-removable Pins: With the exception of electric through wire hinges, provide set screw in hinge barrel that, when tightened into a groove in hinge pin, prevents removal of pin while door is closed; for the all out-swinging lockable doors.

5. Manufacturers:

- a. Hager Companies (HA).
- b. McKinney (MK).

2.3 POWER TRANSFER DEVICES

- A. Concealed Quick Connect Electric Power Transfers: Provide concealed wiring pathway housing mortised into the door and frame for low voltage electrified door hardware. Furnish with Molex™ standardized plug connectors and sufficient number of concealed wires (up to 12) to accommodate the electrified functions specified in the Door Hardware Sets. Connectors plug directly to through-door wiring harnesses for connection to electric locking devices and power supplies. Wire nut connections are not acceptable.

1. Manufacturers:

- a. Pemko (PE) - EL-CEPT Series.
- b. Securitron (SU) - EL-CEPT Series.

- B. Electric Door Wire Harnesses: Provide electric/data transfer wiring harnesses with standardized plug connectors to accommodate up to twelve (12) wires. Connectors plug directly to through-door wiring harnesses for connection to electric locking devices and power supplies. Provide sufficient number and type of concealed wires to accommodate electric function of specified hardware. Provide a connector for through-door electronic locking devices and from hinge to junction box above the opening. Wire nut connections are not acceptable. Determine the length required for each electrified hardware component for the door type, size and construction, minimum of two per electrified opening.

1. Provide one each of the following tools as part of the base bid contract:

- a. McKinney (MK) - Electrical Connecting Kit: QC-R001.
- b. McKinney (MK) - Connector Hand Tool: QC-R003.

2. Manufacturers:

- a. Hager Companies (HA) - Quick Connect.
- b. McKinney (MK) - QC-C Series.

2.4 DOOR OPERATING TRIM

- A. Flush Bolts and Surface Bolts: ANSI/BHMA A156.3 and A156.16, Grade 1, certified.

1. Flush bolts to be furnished with top rod of sufficient length to allow bolt retraction device location approximately six feet from the floor.
2. Furnish dust proof strikes for bottom bolts.
3. Surface bolts to be minimum 8" in length and U.L. listed for labeled fire doors and U.L. listed for windstorm components where applicable.

4. Provide related accessories (mounting brackets, strikes, coordinators, etc.) as required for appropriate installation and operation.
 5. Manufacturers:
 - a. Door Controls International (DC).
 - b. Rockwood (RO).
 - c. Trimco (TC).
- B. Coordinators: ANSI/BHMA A156.3 certified door coordinators consisting of active-leaf, hold-open lever and inactive-leaf release trigger. Model as indicated in hardware sets.
1. Manufacturers:
 - a. Door Controls International (DC).
 - b. Rockwood (RO).
 - c. Trimco (TC).
- C. Door Push Plates and Pulls: ANSI/BHMA A156.6 certified door pushes and pulls of type and design specified in the Hardware Sets. Coordinate and provide proper width and height as required where conflicting hardware dictates.
1. Push/Pull Plates: Minimum .050 inch thick, size as indicated in hardware sets, with beveled edges, secured with exposed screws unless otherwise indicated.
 2. Door Pull and Push Bar Design: Size, shape, and material as indicated in the hardware sets. Minimum clearance of 2 1/2-inches from face of door unless otherwise indicated.
 3. Offset Pull Design: Size, shape, and material as indicated in the hardware sets. Minimum clearance of 2 1/2-inches from face of door and offset of 90 degrees unless otherwise indicated.
 4. Fasteners: Provide manufacturer's designated fastener type as indicated in Hardware Sets.
 5. Manufacturers:
 - a. Hiawatha, Inc. (HI).
 - b. Rockwood (RO).
 - c. Trimco (TC).

2.5 CYLINDERS AND KEYING

- A. General: Cylinder manufacturer to have minimum (10) years experience designing secured master key systems and have on record a published security keying system policy.
- B. Source Limitations: Obtain each type of keyed cylinder and keys from the same source manufacturer as locksets and exit devices, unless otherwise indicated.
- C. Cylinder Types: Original manufacturer cylinders able to supply the following cylinder formats and types:
 1. Threaded mortise cylinders with rings and cams to suit hardware application.
 2. Rim cylinders with back plate, flat-type vertical or horizontal tailpiece, and raised trim ring.
 3. Bored or cylindrical lock cylinders with tailpieces as required to suit locks.

4. Tubular deadlocks and other auxiliary locks.
 5. Mortise and rim cylinder collars to be solid and recessed to allow the cylinder face to be flush and be free spinning with matching finishes.
 6. Keyway: Match Facility Standard.
- D. Keying System: Each type of lock and cylinders to be factory keyed.
1. Supplier shall conduct a "Keying Conference" to define and document keying system instructions and requirements.
 2. Furnish factory cut, nickel-silver large bow permanently inscribed with a visual key control number as directed by Owner.
 3. Existing System: Field verify and key cylinders to match Owner's existing system.
- E. Key Quantity: Provide the following minimum number of keys:
1. Change Keys per Cylinder: Two (2)
 2. Master Keys (per Master Key Level/Group): Five (5).
 3. Construction Keys (where required): Ten (10).
- F. Construction Keying: Provide construction master keyed cylinders.
- G. Key Registration List (Bitting List):
1. Provide keying transcript list to Owner's representative in the proper format for importing into key control software.
 2. Provide transcript list in writing or electronic file as directed by the Owner.

2.6 KEY CONTROL

- A. Key Control Cabinet: Provide a key control system including envelopes, labels, and tags with self-locking key clips, receipt forms, 3-way visible card index, temporary markers, permanent markers, and standard metal cabinet. Key control cabinet shall have expansion capacity of 150% of the number of locks required for the project.
1. Manufacturers:
 - a. Lund Equipment (LU).
 - b. MMF Industries (MM).
 - c. Telkee (TK).

2.7 MECHANICAL LOCKS AND LATCHING DEVICES

- A. Mortise Locksets, Grade 1 (Heavy Duty): ANSI/BHMA A156.13, Series 1000, Operational Grade 1 Certified Products Directory (CPD) listed. Locksets are to be manufactured with a corrosion resistant steel case and be field-reversible for handing without disassembly of the lock body.
1. Manufacturers:
 - a. Corbin Russwin Hardware (RU) - ML2000 Series.
 - b. Sargent Manufacturing (SA) - 8200 Series.

- c. Yale Commercial(YA) - 8800FL Series.

2.8 AUXILIARY LOCKS

- A. Push-Pull Latches, Paddle Type, Mortise: ANSI/BHMA A156.13, Series 1000, Operational and Security Grade 1 Certified Products Directory (CPD) listed mortise type push-pull locks and latches with ligature-resistant paddle trim capable of being mounted in vertical (up or down) and horizontal (sideways) positions. Locksets to be manufactured with a corrosion resistant, formed steel case and be non-handed, field-reversible for re-handing without disassembly of the lock body. Paddles and covers are manufactured from cast stainless steel or brass material. Provide optional lead-lining (lock body) and Torx® fasteners as specified in Hardware Sets.
 - 1. Manufacturers:
 - a. Corbin Russwin Hardware (RU) - ML2000 HPSK Series.
 - b. Sargent Manufacturing (SA) - 8200 ALP Series.

2.9 LOCK AND LATCH STRIKES

- A. Strikes: Provide manufacturer's standard strike with strike box for each latch or lock bolt, with curved lip extended to protect frame, finished to match door hardware set, unless otherwise indicated, and as follows:
 - 1. Flat-Lip Strikes: For locks with three-piece antifriction latchbolts, as recommended by manufacturer.
 - 2. Extra-Long-Lip Strikes: For locks used on frames with applied wood casing trim.
 - 3. Aluminum-Frame Strike Box: Provide manufacturer's special strike box fabricated for aluminum framing.
 - 4. Double-lipped strikes: For locks at double acting doors. Furnish with retractable stop for rescue hardware applications.
- B. Standards: Comply with the following:
 - 1. Strikes for Mortise Locks and Latches: BHMA A156.13.
 - 2. Strikes for Bored Locks and Latches: BHMA A156.2.
 - 3. Strikes for Auxiliary Deadlocks: BHMA A156.36.
 - 4. Dustproof Strikes: BHMA A156.16.

2.10 ELECTRIC STRIKES

- A. Standard Electric Strikes: Electric strikes tested to ANSI/BHMA A156.31, Grade 1, for use on non-rated or fire rated openings. Strikes shall be of stainless steel construction tested to a minimum of 1500 pounds of static strength and 70 foot-pounds of dynamic strength with a minimum endurance of 1 million operating cycles. Provide strikes with 12 or 24 VDC capability, fail-secure unless otherwise specified. Where specified provide latchbolt and latchbolt strike monitoring indicating both the position of the latchbolt and locked condition of the strike.
 - 1. Manufacturers:
 - a. HES (HS) - 1500/1600 Series.

- B. Provide electric strikes with in-line power controller and surge suppressor by the same manufacturer as the strike with the combined products having a five year warranty.

2.11 DOOR CLOSERS

- A. All door closers specified herein shall meet or exceed the following criteria:
 - 1. General: Door closers to be from one manufacturer, matching in design and style, with the same type door preparations and templates regardless of application or spring size. Closers to be non-handed with full sized covers.
 - 2. Standards: Closers to comply with UL-10C for Positive Pressure Fire Test and be U.L. listed for use of fire rated doors.
 - 3. Size of Units: Comply with manufacturer's written recommendations for sizing of door closers depending on size of door, exposure to weather, and anticipated frequency of use. Where closers are indicated for doors required to be accessible to the Americans with Disabilities Act, provide units complying with ANSI ICC/A117.1.
 - 4. Closer Arms: Provide heavy duty, forged steel closer arms unless otherwise indicated in Hardware Sets.
 - 5. Closers shall not be installed on exterior or corridor side of doors; where possible install closers on door for optimum aesthetics.
 - 6. Closer Accessories: Provide door closer accessories including custom templates, special mounting brackets, spacers and drop plates as required for proper installation. Provide through-bolt and security type fasteners as specified in the hardware sets.
- B. Door Closers, Surface Mounted (Heavy Duty): ANSI/BHMA A156.4, Grade 1 Certified Products Directory (CPD) listed surface mounted, heavy duty door closers with complete spring power adjustment, sizes 1 thru 6; and fully operational adjustable according to door size, frequency of use, and opening force. Closers to be rack and pinion type, one piece cast iron or aluminum alloy body construction, with adjustable backcheck and separate non-critical valves for closing sweep and latch speed control. Provide non-handed units standard.
 - 1. Manufacturers:
 - a. Norton Rixson (NO) - 7500 Series.
 - b. Sargent Manufacturing (SA) - 351 Series.

2.12 ARCHITECTURAL TRIM

- A. Door Protective Trim
 - 1. General: Door protective trim units to be of type and design as specified below or in the Hardware Sets.
 - 2. Size: Fabricate protection plates (kick, armor, or mop) not more than 2" less than door width (LDW) on stop side of single doors and 1" LDW on stop side of pairs of doors, and not more than 1" less than door width on pull side. Coordinate and provide proper width

and height as required where conflicting hardware dictates. Height to be as specified in the Hardware Sets.

3. Where plates are applied to fire rated doors with the top of the plate more than 16" above the bottom of the door, provide plates complying with NFPA 80. Consult manufacturer's catalog and template book for specific requirements for size and applications.
4. Protection Plates: ANSI/BHMA A156.6 certified protection plates (kick, armor, or mop), fabricated from the following:
 - a. Stainless Steel: 300 grade, 050-inch thick.
5. Options and fasteners: Provide manufacturer's designated fastener type as specified in the Hardware Sets. Provide countersunk screw holes.
6. Manufacturers:
 - a. Hiawatha, Inc. (HI).
 - b. Rockwood (RO).
 - c. Trimco (TC).

2.13 DOOR STOPS AND HOLDERS

- A. General: Door stops and holders to be of type and design as specified below or in the Hardware Sets.
- B. Door Stops and Bumpers: ANSI/BHMA A156.16, Grade 1 certified door stops and wall bumpers. Provide wall bumpers, either convex or concave types with anchorage as indicated, unless floor or other types of door stops are specified in Hardware Sets. Do not mount floor stops where they will impede traffic. Where floor or wall bumpers are not appropriate, provide overhead type stops and holders.
 1. Manufacturers:
 - a. Hiawatha, Inc. (HI).
 - b. Rockwood (RO).
 - c. Trimco (TC).

2.14 ARCHITECTURAL SEALS

- A. General: Thresholds, weatherstripping, and gasket seals to be of type and design as specified below or in the Hardware Sets. Provide continuous weatherstrip gasketing on exterior doors and provide smoke, light, or sound gasketing on interior doors where indicated. At exterior applications provide non-corrosive fasteners and elsewhere where indicated.
- B. Smoke Labeled Gasketing: Assemblies complying with NFPA 105 that are listed and labeled by a testing and inspecting agency acceptable to authorities having jurisdiction, for smoke control ratings indicated, based on testing according to UL 1784.
 1. Provide smoke labeled perimeter gasketing at all smoke labeled openings.

- C. Fire Labeled Gasketing: Assemblies complying with NFPA 80 that are listed and labeled by a testing and inspecting agency acceptable to authorities having jurisdiction, for fire ratings indicated, based on testing according to UL-10C.
 - 1. Provide intumescent seals as indicated to meet UL10C Standard for Positive Pressure Fire Tests of Door Assemblies, and NPFA 252, Standard Methods of Fire Tests of Door Assemblies.
- D. Sound-Rated Gasketing: Assemblies that are listed and labeled by a testing and inspecting agency, for sound ratings indicated.
- E. Replaceable Seal Strips: Provide only those units where resilient or flexible seal strips are easily replaceable and readily available from stocks maintained by manufacturer.
- F. Manufacturers:
 - 1. Pemko (PE).

2.15 FABRICATION

- A. Fasteners: Provide door hardware manufactured to comply with published templates generally prepared for machine, wood, and sheet metal screws. Provide screws according to manufacturers recognized installation standards for application intended.

2.16 FINISHES

- A. Standard: Designations used in the Hardware Sets and elsewhere indicate hardware finishes complying with ANSI/BHMA A156.18, including coordination with traditional U.S. finishes indicated by certain manufacturers for their products.
- B. Provide quality of finish, including thickness of plating or coating (if any), composition, hardness, and other qualities complying with manufacturer's standards, but in no case less than specified by referenced standards for the applicable units of hardware
- C. Protect mechanical finishes on exposed surfaces from damage by applying a strippable, temporary protective covering before shipping.

PART 3 - EXECUTION

3.1 EXAMINATION

- A. Examine scheduled openings, with Installer present, for compliance with requirements for installation tolerances, labeled fire door assembly construction, wall and floor construction, and other conditions affecting performance.
- B. Notify architect of any discrepancies or conflicts between the door schedule, door types, drawings and scheduled hardware. Proceed only after such discrepancies or conflicts have been resolved in writing.

3.2 PREPARATION

- A. Hollow Metal Doors and Frames: Comply with ANSI/DHI A115 series.
- B. Wood Doors: Comply with ANSI/DHI A115-W series.

3.3 INSTALLATION

- A. Install each item of mechanical and electromechanical hardware and access control equipment to comply with manufacturer's written instructions and according to specifications.
 - 1. Installers are to be trained and certified by the manufacturer on the proper installation and adjustment of fire, life safety, and security products including: hanging devices; locking devices; closing devices; and seals.
- B. Mounting Heights: Mount door hardware units at heights indicated in following applicable publications, unless specifically indicated or required to comply with governing regulations:
 - 1. Standard Steel Doors and Frames: DHI's "Recommended Locations for Architectural Hardware for Standard Steel Doors and Frames."
 - 2. DHI TDH-007-20: Installation Guide for Doors and Hardware.
 - 3. Where indicated to comply with accessibility requirements, comply with ANSI A117.1 "Accessibility Guidelines for Buildings and Facilities."
 - 4. Provide blocking in drywall partitions where wall stops or other wall mounted hardware is located.
- C. Retrofitting: Install door hardware to comply with manufacturer's published templates and written instructions. Where cutting and fitting are required to install door hardware onto or into surfaces that are later to be painted or finished in another way, coordinate removal, storage, and reinstallation of surface protective trim units with finishing work specified in Division 9 Sections. Do not install surface-mounted items until finishes have been completed on substrates involved.
- D. Thresholds: Set thresholds for exterior and acoustical doors in full bed of sealant complying with requirements specified in Division 7 Section "Joint Sealants."
- E. Storage: Provide a secure lock up for hardware delivered to the project but not yet installed. Control the handling and installation of hardware items so that the completion of the work will not be delayed by hardware losses before and after installation.

3.4 FIELD QUALITY CONTROL

- A. Field Inspection (Punch Report): Reference Division 01 Sections "Closeout Procedures". Produce project punch report for each installed door opening indicating compliance with approved submittals and verification hardware is properly installed, operating and adjusted. Include list of items to be completed and corrected, indicating the reasons or deficiencies causing the Work to be incomplete or rejected.
 - 1. Organization of List: Include separate Door Opening and Deficiencies and Corrective Action Lists organized by Mark, Opening Remarks and Comments, and related Opening Images and Video Recordings.

3.5 ADJUSTING

- A. Initial Adjustment: Adjust and check each operating item of door hardware and each door to ensure proper operation or function of every unit. Replace units that cannot be adjusted to operate as intended. Adjust door control devices to compensate for final operation of heating and ventilating equipment and to comply with referenced accessibility requirements.

3.6 CLEANING AND PROTECTION

- A. Protect all hardware stored on construction site in a covered and dry place. Protect exposed hardware installed on doors during the construction phase. Install any and all hardware at the latest possible time frame.
- B. Clean adjacent surfaces soiled by door hardware installation.
- C. Clean operating items as necessary to restore proper finish. Provide final protection and maintain conditions that ensure door hardware is without damage or deterioration at time of owner occupancy.

3.7 DEMONSTRATION

- A. Instruct Owner's maintenance personnel to adjust, operate, and maintain mechanical and electromechanical door hardware.

3.8 DOOR HARDWARE SETS

- A. The hardware sets represent the design intent and direction of the owner and architect. They are a guideline only and should not be considered a detailed hardware schedule. Discrepancies, conflicting hardware and missing items should be brought to the attention of the architect with corrections made prior to the bidding process. Omitted items not included in a hardware set should be scheduled with the appropriate additional hardware required for proper application and functionality.
 - 1. Quantities listed are for each pair of doors, or for each single door.
 - 2. The supplier is responsible for handing and sizing all products.
 - 3. Where multiple options for a piece of hardware are given in a single line item, the supplier shall provide the appropriate application for the opening.
 - 4. At existing openings with new hardware the supplier shall field inspect existing conditions prior to the submittal stage to verify the specified hardware will work as required. Provide alternate solutions and proposals as needed.
- B. Manufacturer's Abbreviations:

C. Refer to Section 080671, Door Hardware Sets, for hardware sets.

1. MK - McKinney
2. BO - Bommer Industries
3. RO - Rockwood
4. YA - Yale
5. SA - SARGENT
6. OT - Other
7. HS - HES
8. FO - Folger Adam
9. NO - Norton
10. BM - Besam
11. PE - Pemko
12. SU - Securitron

Hardware Sets

Set: 1.0

Doors: 1D42, 2C31

1 Hinge, Full Mortise	TA2714	US26D	MK
1 Storeroom or Closet Lock	PBR 8805FL	626	YA
1 Cylinder & Core	to match facility standard		OT
1 Surface Closer	7500 tri pack mounting as req'd	689	NO
1 Kick Plate	K1050 10" high CSK BEV	US32D	RO
1 Stop	406 / 409 / 441CU as req'd	US26D	RO
1 Gasketing	S88BL		PE

Set: 2.0

Doors: 1D41

6 Hinge, Full Mortise	TA2714	US26D	MK
1 Flush Bolt	2842 / 2942 as req'd	US26D	RO
1 Entry Lock	PBR 8807FL	626	YA
1 Cylinder & Core	to match facility standard		OT
1 Coordinator	2660	US28	RO
2 Surface Closer	7500 tri pack mounting as req'd	689	NO
2 Kick Plate	K1050 10" high CSK BEV	US32D	RO
2 Stop	406 / 409 / 441CU as req'd	US26D	RO
1 Gasketing	S88BL		PE

Set: 3.0

Doors: 2C27, 2C29, 2D01, 2D02, 2D03

1 Hinge, Full Mortise	TA2714	US26D	MK
1 Passage Latch	PBR 8801FL	626	YA
1 Stop	406 / 409 / 441CU as req'd	US26D	RO
1 Gasketing	S88BL		PE

Set: 4.0

Doors: 2D27A

1 Hinge, Full Mortise	TA2314	US32D	MK
1 Passage Latch (Paddle Trim)	8215 ALP	US32D	SA
1 Surface Closer	7500 tri pack mounting as req'd	689	NO
1 Kick Plate	K1050 10" high CSK BEV	US32D	RO
1 Stop	406 / 409 / 441CU as req'd	US26D	RO
1 Gasketing	S88BL		PE

Set: 5.0

Doors: 2D27B

6 Hinge, Full Mortise	TA2314	US32D	MK
1 Flush Bolt	2842 / 2942 as req'd	US26D	RO
1 Passage Latch (Paddle Trim)	8215 ALP	US32D	SA
1 Electric Strike	310-2 series as req'd	630	FO ✕
1 Automatic Operator (Surface Pair)	SW200i surface pair		BM
2 Kick Plate	K1050 10" high CSK BEV	US32D	RO
2 Stop	406 / 409 / 441CU as req'd	US26D	RO
1 Gasketing	S88BL		PE
1 Frame Harness	QC-C1500P		MK ✕
1 Door Harness	QC-Cxx		MK ✕
2 Wave to Open Switch	700		NO ✕
1 Electric Power Transfer	EL-CEPT	630	SU ✕

Set: 6.0

Doors: 2D27C

1 All Hardware	Hardware by door manufacturer		OT
----------------	-------------------------------	--	----

END OF SECTION

THIS PAGE LEFT BLANK INTENTIONALLY

SECTION 08 8000

GLAZING

PART 1 - GENERAL

1.1 RELATED DOCUMENTS

- A. Drawings and general provisions of the Contract, including General and Supplementary Conditions and Division 1 Specification Sections, apply to this Section.

1.2 SUMMARY

- A. **This Section includes** glazing for the following products and applications, including those specified in other Sections where glazing requirements are specified by reference to this Section:
 - 1. Windows.
 - 2. Doors.
 - 3. Glazed entrances.
 - 4. Pressure-sensitive window film.
- B. **Related Sections:**
 - 1. Section 05 5000 "**Metal Fabrications**" for **aluminum glazing channels** at interior locations.

1.3 DEFINITIONS

- A. **Manufacturer:** A firm that produces primary glass or fabricated glass as defined in referenced glazing publications.
- B. **Interspace:** Space between lites of an insulating-glass unit that contains dehydrated air or a specified gas.
- C. **Deterioration of Coated Glass:** Defects developed from normal use that are attributed to the manufacturing process and not to causes other than glass breakage and practices for maintaining and cleaning coated glass contrary to manufacturer's written instructions. Defects include peeling, cracking, and other indications of deterioration in metallic coating.
- D. **Deterioration of Insulating Glass:** Failure of the hermetic seal under normal use that is attributed to the manufacturing process and not to causes other than glass breakage and practices for maintaining and cleaning insulating glass contrary to manufacturer's written instructions. Evidence of failure is the obstruction of vision by dust, moisture, or film on interior surfaces of glass.

1.4 PERFORMANCE REQUIREMENTS

- A. **General:** Provide glazing systems capable of withstanding normal thermal movement and wind and impact loads (where applicable) without failure, including loss or glass breakage attributable to the following: defective manufacture, fabrication, and installation; failure of sealants or gaskets to remain watertight and airtight; deterioration of glazing materials; or other defects in construction.

- B. **Glass Design:** Glass thicknesses indicated are minimums and are for detailing only. Confirm glass thicknesses by analyzing Project loads and in-service conditions. Provide glass lites for various size openings in nominal thicknesses indicated, but not less than thicknesses and in strengths (annealed or heat treated) required.
- C. **Thermal Movements:** Provide glazing that allows for thermal movements resulting from the following maximum change (range) in ambient and surface temperatures acting on glass framing members and glazing components. Base engineering calculation on surface temperatures of materials due to both solar heat gain and nighttime-sky heat loss.
 - 1. Temperature Change (Range): 120 degrees F, ambient; 180 degrees F, material surfaces.

1.5 SUBMITTALS

- A. **Product Data:** For each glass product and glazing material indicated.
- B. **Samples:** 12-inch- square Samples for film and of 12-inch- long Samples for sealants.
- C. **Glazing Schedule:** Use same designations indicated on Drawings for glazed openings in preparing a schedule listing glass types and thicknesses for each size opening and location.
- D. **Product Certificates:** Signed by manufacturers of glass and glazing products certifying that products furnished comply with requirements.
- E. **Warranties:** Special warranties specified in this Section.

1.6 QUALITY ASSURANCE

- A. **Installer Qualifications:** : An experienced installer who has completed glazing similar in material, design and extent to that indicated for this project; whose work has resulted in glass installations with a record of successful in-service performance.
- B. **Source Limitations for Clear Glass:** Obtain clear float glass from one primary-glass manufacturer.
- C. **Source Limitations for Glazing Accessories:** Obtain glazing accessories from one source for each product and installation method indicated.
- D. **Safety Glass:** Category II materials complying with testing requirements in 16 CFR 1201 and ANSI Z97.1.
 - 1. Subject to compliance with requirements, permanently mark safety glass with certification label of Safety Glazing Certification Council or another certification agency acceptable to authorities having jurisdiction.
- M. **Glazing Publications:** Comply with published recommendations of glass product manufacturers and organizations below, unless more stringent requirements are indicated. Refer to these publications for glazing terms not otherwise defined in this Section or in referenced standards.
 - 1. GANA Publications: GANA'S "Glazing Manual" and "Laminated Glass Design Guide."

1.7 DELIVERY, STORAGE, AND HANDLING

- A. **Protect glazing materials** according to manufacturer's written instructions and as needed to prevent damage to glass and glazing materials from condensation, temperature changes, direct exposure to sun, or other causes.

1.8 PROJECT CONDITIONS

- A. **Environmental Limitations:** Do not proceed with glazing when ambient and substrate temperature conditions are outside limits permitted by glazing material manufacturers and when glazing channel substrates are wet from rain, frost, condensation, or other causes.
 - 1. Do not install liquid glazing sealants when ambient and substrate temperature conditions are outside limits permitted by glazing sealant manufacturer or below 40 degrees F.

1.9 WARRANTY

- A. **General Warranty:** Special warranties specified in this Article shall not deprive Owner of other rights Owner may have under other provisions of the Contract Documents and shall be in addition to, and run concurrent with, other warranties made by Contractor under requirements of the Contract Documents.

PART 2 - PRODUCTS

2.1 PRIMARY FLOAT GLASS

- A. **Float Glass:** ASTM C 1036, Type I (transparent glass, flat), Quality q3 (glazing select); class as indicated in schedules at the end of Part 3.

2.2 HEAT-TREATED FLOAT GLASS

- A. **Fabrication Process:** By horizontal (roller-hearth) process with roll-wave distortion parallel to bottom edge of glass as installed, unless otherwise indicated.
- B. **Heat-Treated Float Glass:** ASTM C 1048; Type I (transparent glass, flat); Quality q3 (glazing select); class, kind, and condition as indicated in schedules at the end of Part 3.

2.3 PRESSURE SENSITIVE WINDOW FILM

- A. **Provide pressure-sensitive vinyl film** where indicated on Drawings.
 - 1. **Basis of Design:** Contract Documents are based on product specified below to establish a standard of quality. Other manufacturers offering products with equivalent characteristics maybe considered, provided deviations are minor and design concept is not changed, as judged by the Architect.
 - 1. Manufacturer: 3M
 - 2. Product: 'Scotchcal' ElectroCut™ Graphic Film 7725SE-324; "Frosted Crystal".
 - 2. **Description:** 3.25 mil, permanent, pressure sensitive film with solvent-based acrylic adhesive.

2.4 ELASTOMERIC GLAZING SEALANTS

- A. **General:** Provide products of type indicated, complying with the following requirements:
1. **Compatibility:** Select glazing sealants that are compatible with one another and with other materials they will contact, including glass products, seals of insulating-glass units, and glazing channel substrates, under conditions of service and application, as demonstrated by sealant manufacturer based on testing and field experience.
 2. **Suitability:** Comply with sealant and glass manufacturers' written instructions for selecting glazing sealants suitable for applications indicated and for conditions existing at time of installation.
 3. **Colors of Exposed Glazing Sealants:** As selected by Architect from manufacturer's full range for this characteristic.
- B. **Elastomeric Glazing Sealant Standard:** Comply with ASTM C 920 and other requirements indicated for each liquid-applied, chemically curing sealant in the Glazing Sealant Schedule at the end of Part 3, including those referencing ASTM C 920 classifications for type, grade, class, and uses.
1. **Additional Movement Capability:** Where additional movement capability is specified in the Glazing Sealant Schedule, provide products with the capability, when tested for adhesion and cohesion under maximum cyclic movement per ASTM C 719, to withstand the specified percentage change in the joint width existing at time of installation and remain in compliance with other requirements in ASTM C 920 for uses indicated.
- C. **Glazing Sealant for Fire-Resistive Glazing Products:** Identical to product used in test assembly to obtain fire-protection rating.

2.5 GLAZING TAPES

- A. **Back-Bedding Mastic Glazing Tape:** Preformed, butyl-based elastomeric tape with a solids content of 100 percent; non-staining and non-migrating in contact with nonporous surfaces; with or without spacer rod as recommended in writing by tape and glass manufacturers for application indicated; packaged on rolls with a release paper backing; and complying with ASTM C 1281 and AAMA 800 for products indicated below:
1. AAMA 806.3 tape, for glazing applications in which tape is subject to continuous pressure.
- B. **Expanded Cellular Glazing Tape:** Closed-cell, PVC foam tape; factory coated with adhesive on both surfaces; packaged on rolls with release liner protecting adhesive; and complying with AAMA 800 for the following types:
1. Type 1, for glazing applications in which tape acts as the primary sealant.
 2. Type 2, for glazing applications in which tape is used in combination with a full bead of liquid sealant.

2.6 GLAZING GASKETS

- A. **Soft Compression Gaskets:** Extruded or molded, closed-cell, integral-skinned gaskets of material indicated below; complying with ASTM C 509, Type II, black; and of profile and hardness required to maintain watertight seal:
1. Neoprene.
 2. EPDM.
 3. Silicone.
 4. Thermoplastic polyolefin rubber.
 5. Any material indicated above.

2.7 MISCELLANEOUS GLAZING MATERIALS

- A. **General:** Provide products of material, size, and shape complying with referenced glazing standard, requirements of manufacturers of glass and other glazing materials for application indicated, and with a proven record of compatibility with surfaces contacted in installation.
- B. **Cleaners, Primers, and Sealers:** Types recommended by sealant or gasket manufacturer.
- C. **Setting Blocks:** Elastomeric material with a Shore A durometer hardness of 85, plus or minus 5.
- D. **Spacers:** Elastomeric blocks or continuous extrusions with a Shore A durometer hardness required by glass manufacturer to maintain glass lites in place for installation indicated.
- E. **Edge Blocks:** Elastomeric material of hardness needed to limit glass lateral movement (side walking).
- F. **Cylindrical Glazing Sealant Backing:** ASTM C 1330, Type O (open-cell material), of size and density to control glazing sealant depth and otherwise produce optimum glazing sealant performance.

2.8 FABRICATION OF GLASS AND OTHER GLAZING PRODUCTS

- A. **Fabricate glass** and other glazing products in sizes required to glaze openings indicated for Project, with edge and face clearances, edge and surface conditions, and bite complying with written instructions of product manufacturer and referenced glazing standard, to comply with system performance requirements.
- B. **Clean-cut or flat-grind vertical edges** of butt-glazed monolithic lites in a manner that produces square edges with slight kerfs at junctions with indoor and outdoor faces.
- C. **Grind smooth** and polish exposed glass edges.

PART 3 - EXECUTION

3.1 EXAMINATION

- A. **Examine framing glazing**, with Installer present, for compliance with the following:
 - 1. Manufacturing and installation tolerances, including those for size, squareness, and offsets at corners.
 - 2. Presence and functioning of weep system.
 - 3. Minimum required face or edge clearances.
 - 4. Effective sealing between joints of glass-framing members.
- B. Proceed with installation only after unsatisfactory conditions have been corrected.

3.2 PREPARATION

- A. **Clean glazing channels** and other framing members receiving glass immediately before glazing. Remove coatings not firmly bonded to substrates.

3.3 GLAZING, GENERAL

- A. **Comply with combined written instructions** of manufacturers of glass, sealants, gaskets, and other glazing materials, unless more stringent requirements are indicated, including those in referenced glazing publications.
- B. **Glazing channel dimensions**, as indicated on Drawings, provide necessary bite on glass, minimum edge and face clearances, and adequate sealant thicknesses, with reasonable tolerances. Adjust as required by Project conditions during installation.
- C. **Protect glass edges** from damage during handling and installation. Remove damaged glass from Project site and legally dispose of off Project site. Damaged glass is glass with edge damage or other imperfections that, when installed, could weaken glass and impair performance and appearance.
- D. **Apply primers** to joint surfaces where required for adhesion of sealants, as determined by preconstruction sealant-substrate testing.
- E. **Install setting blocks** in sill rabbets, sized and located to comply with referenced glazing publications, unless otherwise required by glass manufacturer. Set blocks in thin course of compatible sealant suitable for heel bead.
- F. **Do not exceed edge pressures** stipulated by glass manufacturers for installing glass lites.
- G. **Provide spacers** for glass lites where the length plus width is larger than 50 inches as follows:
 - 1. Locate spacers directly opposite each other on both inside and outside faces of glass. Install correct size and spacing to preserve required face clearances, unless gaskets and glazing tapes are used that have demonstrated ability to maintain required face clearances and to comply with system performance requirements.
 - 2. Provide 1/8-inch minimum bite of spacers on glass and use thickness equal to sealant width. With glazing tape, use thickness slightly less than final compressed thickness of tape.
- H. **Provide edge blocking** where indicated or needed to prevent glass lites from moving sideways in glazing channel, as recommended in writing by glass manufacturer and according to requirements in referenced glazing publications.
- I. **Set glass lites** in each series with uniform pattern, draw, bow, and similar characteristics.
- J. **Where wedge-shaped gaskets are driven into one side of channel** to pressurize sealant or gasket on opposite side, provide adequate anchorage so gasket cannot walk out when installation is subjected to movement.
- K. **Square cut wedge-shaped gaskets** at corners and install gaskets in a manner recommended by gasket manufacturer to prevent corners from pulling away; seal corner joints and butt joints with sealant recommended by gasket manufacturer.

3.4 TAPE GLAZING

- A. **Position tapes** on fixed stops so that, when compressed by glass, their exposed edges are flush with or protrude slightly above sightline of stops.

- B. **Install tapes continuously**, but not necessarily in one continuous length. Do not stretch tapes to make them fit opening.
- C. **Where framing joints are vertical**, cover these joints by applying tapes to heads and sills first and then to jambs. Where framing joints are horizontal, cover these joints by applying tapes to jambs and then to heads and sills.
- D. **Place joints in tapes** at corners of opening with adjoining lengths butted together, not lapped. Seal joints in tapes with compatible sealant approved by tape manufacturer.
- E. **Do not remove release paper** from tape until just before each glazing unit is installed.
- F. **Apply heel bead** of elastomeric sealant.
- G. **Center glass lites in openings** on setting blocks and press firmly against tape by inserting dense compression gaskets formed and installed to lock in place against faces of removable stops. Start gasket applications at corners and work toward centers of openings.
- H. **Apply cap bead** of elastomeric sealant over exposed edge of tape.

3.5 GASKET GLAZING (DRY)

- A. **Fabricate compression gaskets** in lengths recommended by gasket manufacturer to fit openings exactly, with stretch allowance during installation.
- B. **Insert soft compression gasket** between glass and frame or fixed stop so it is securely in place with joints miter cut and bonded together at corners.
- C. **Center glass lites in openings** on setting blocks and press firmly against soft compression gasket by inserting dense compression gaskets formed and installed to lock in place against faces of removable stops. Start gasket applications at corners and work toward centers of openings. Compress gaskets to produce a weathertight seal without developing bending stresses in glass. Seal gasket joints with sealant recommended by gasket manufacturer.
- D. **Install gaskets** so they protrude past face of glazing stops.

3.6 SEALANT GLAZING (WET)

- A. **Install continuous spacers**, or spacers combined with cylindrical sealant backing, between glass lites and glazing stops to maintain glass face clearances and to prevent sealant from extruding into glass channel and blocking weep systems until sealants cure. Secure spacers or spacers and backings in place and in position to control depth of installed sealant relative to edge clearance for optimum sealant performance.
- B. **Force sealants** into glazing channels to eliminate voids and to ensure complete wetting or bond of sealant to glass and channel surfaces.
- C. **Tool exposed surfaces** of sealants to provide a substantial wash away from glass.

3.7 PROTECTION AND CLEANING

- A. **Protect exterior glass** from damage immediately after installation by attaching crossed streamers to framing held away from glass. Do not apply markers to glass surface. Remove nonpermanent labels, and clean surfaces.
- B. **Protect glass from contact with contaminating substances** resulting from construction operations, including weld splatter. If, despite such protection, contaminating substances do come into contact with glass, remove them immediately as recommended by glass manufacturer.
- C. **Examine glass surfaces** adjacent to or below exterior concrete and other masonry surfaces at frequent intervals during construction, but not less than once a month, for build-up of dirt, scum, alkaline deposits, or stains; remove as recommended by glass manufacturer.
- D. **Remove and replace** glass that is broken, chipped, cracked, abraded, or damaged in any way, including natural causes, accidents, and vandalism, during construction period.
- E. **Wash glass on both exposed surfaces** in each area of Project not more than four days before date scheduled for inspections that establish date of Substantial Completion. Wash glass as recommended by glass manufacturer.

3.8 MONOLITHIC FLOAT-GLASS SCHEDULE

- A. **Type 1:** 1/4 inch clear float; fully tempered where noted on Drawings or required by governing code.
- B. **Type 2:** 1/2 inch clear float; fully tempered where noted on Drawings or required by governing code.
- C. **Uncoated Clear Float Glass:** Where glass as designated below is indicated, provide Type I (transparent glass, flat), Class 1 (clear) glass lites complying with the following:
 - 1. Uncoated Clear Annealed Float Glass: Annealed or Kind HS (heat strengthened), Condition A (uncoated surfaces) where heat strengthening is required to resist thermal stresses induced by differential shading of individual glass lites and to comply with performance requirements.
 - 2. Uncoated Clear Heat-Strengthened Float Glass: Kind HS (heat strengthened).
 - 3. Uncoated Clear Fully Tempered Float Glass: Kind FT (fully tempered).
Provide as required and as indicated.

3.9 GLAZING SEALANT SCHEDULE

- A. **Low-Modulus Nonacid-Curing Silicone Glazing Sealant:** Where glazing sealants of this designation are indicated, provide products complying with the following:
1. Products: Available products include the following:
 - a. 790; Dow Corning.
 - b. UltraPruf SCS2300; GE Silicones.
 - c. Spectrem 1; Tremco.
 2. Type and Grade: S (single component) and NS (nonsag).
 3. Class: 25.
 4. Additional Movement Capability: 50 percent movement in extension and 50 percent movement in compression for a total of 100 percent movement.
 5. Use Related to Exposure: NT (nontraffic).
 6. Uses Related to Glazing Substrates: M, G, A, and, as applicable to glazing substrates indicated, O.
 - a. Use O Glazing Substrates: Coated glass, color anodic aluminum, aluminum coated with a high-performance coating, galvanized steel, and wood.

END OF SECTION

THIS PAGE LEFT BLANK INTENTIONALLY

SECTION 08 8816

VISION CONTROL GLASS

- GENERAL

1.1 RELATED DOCUMENTS

- A. Drawings and general provisions of the Contract, including General and Supplementary Conditions and Division 1 Specification Sections, apply to this Section.

1.2 SUMMARY

- A. **Section Includes:**
 - 1. Vision control glass with adjustable cordless louvers.
 - 2. Manual operators.
- B. **Related Sections:**
 - 1. Section 08 1113 "**Hollow Metal Doors and Frames**" for frames to receive vision control glass system

1.3 REFERENCES

- A. **American National Standards Institute (ANSI)** Z97.1 - Safety Performance Specifications and Methods of Test for Safety Glazing Material Used in Buildings.
- B. **ASTM International (ASTM):**
 - 1. C864 - Standard Specification for Dense Elastomeric Compression Seal Gaskets, Setting Blocks, and Spacers.
 - 2. C920 - Standard Specification for Elastomeric Joint Sealants.
 - 3. C1048 - Standard Specification for Heat-Treated Flat Glass-Kind HS, Kind FT, Coated and Uncoated Glass.
 - 4. C1115 - Standard Specification for Dense Elastomeric Silicone Rubber Gaskets and Accessories.
 - 5. C1294 - Standard Test Method for Compatibility of Insulating Glass Edge Sealants with Liquid-Applied Glazing Materials.
 - 6. C1330 - Standard Specification for Cylindrical Sealant Backing for Use with Cold Liquid Applied Sealants.
 - 7. E2190 - Standard Specification for Insulating Glass Units Performance and Evaluation.
- C. **Consumer Product Safety Commission (CPSC)** 16 CFR 1201 - Safety Standard for Architectural Glazing Materials.
- D. **Glass Association of North America (GANA)** - Engineering Standards Manual.

1.4 SUBMITTALS

- A. **Submittals for Review:**
 - 1. Product Data: Descriptive data and performance attributes for vision control glass.
 - 2. Samples: 8-1/2 x 13-1/2 inch vision control glass samples.

- B. **Closeout Submittals:**
 - 1. Maintenance Instructions: Manufacturer's printed instructions for cleaning and maintenance of glazed units, including operators.

1.5 SYSTEM DESCRIPTION

- A. **Vision Control Glass:** Control vision through insulated glass unit assemblies by means of rotating, cordless, interlocking, horizontal, extruded aluminum louvers with rotation controlled manually. Rotation of louvers results in reduction in or elimination of vision through glazed assemblies.

1.6 QUALITY ASSURANCE

- A. **Regulatory Requirements:**
 - 1. Provide tempered safety glass for locations subject to human impact as required by authority having jurisdiction.
 - 2. Safety glass: Tested and labeled to CPSC 16 CFR 1201.
- B. **Perform Work** in accordance with GANA Glazing Manual.
- C. **Mockup:**
 - 1. Provide mockup of vision control glass unit.
 - 2. Locate where directed.
 - 3. Approved mockup may not remain as part of the Work.

1.7 DELIVERY, STORAGE AND HANDLING

- A. **Deliver and store glass units** in upright position, on blocks, in dry and safe location.
- B. **Do not place units** in direct sunlight.
- C. **Handle units** using corner protectors.

1.8 WARRANTIES

- A. **Vision Control Glass in Interior Locations:** Furnish manufacturer's 20-year warranty providing coverage against malfunction, mechanism failure and premature wear of internal parts, and material obstruction of glass units by dust or film formation due to failure of hermetic seal.

PART 2 - PRODUCTS

2.1 MANUFACTURERS

- A. **Acceptable Manufacturer:** Subject to compliance with requirements of the Contract Documents, provide product by the following manufacturer:
 - 1. Manufacturer: Unicel Architectura; www.unicelarchitectural.com.
 - 2. Product: Vision Control Insulating Glass with Integrated Cord-Free Louvers.
- B. **Substitutions:** Not permitted.

2.2 MATERIALS - GLASS

- A. **Clear Tempered Glass:** ASTM C1048, Type 1 transparent flat, Class 1 clear, Quality q3 glazing select, Kind FT fully tempered.

2.3 MATERIALS - LOUVERS, FRAMES, AND OPERATORS

- A. **Louvers:** Hollow extruded aluminum, interlocking profile, 3/16 inch-thick x 7/8 inch deep; finish as selected by Architect from manufacturer's full range.
- B. **Manual Operators:** Anti-ligature knob type.
- C. **Glass Framing System:** Extruded aluminum, sized to accept Vision Control glass, for insertion into hollow metal in interior wall partitions:
 - 1. **Glass stops:** Aluminum stops (base + snap-on on both sides, screws excluded) 1 inch deep x 1-3/4 inch high pre-cut and drilled or notched to accept Vision Control or Vision Control Mini operating mechanisms, ready for installation into frames; finish as selected by Architect from manufacturer's full range..

2.4 ACCESSORIES

- A. **Setting Blocks:** ASTM C864, neoprene or EPDM, or ASTM C1115, silicone; 70 to 90 Shore A durometer hardness.
- B. **Spacers:** ASTM C864, neoprene or EPDM, or ASTM C1115, silicone; 50 to 60 Shore A durometer hardness.
- C. **Glazing Gaskets:** ASTM C864, neoprene or EPDM, or ASTM C1115, silicone or thermoplastic polyolefin rubber, molded or extruded shape to fit glazing channel retaining slot.
- D. **Glazing Sealant:**
 - 1. ASTM C920, Type M, Grade NS, Class 25; two component silicone type, low modulus, non-sag.
 - 2. Sealant backing: ASTM C1330, Type O, size and density to control glazing sealant depth and produce optimum glazing sealant performance.
 - 3. Compatible with glass unit edge seals; tested to ASTM C1294.

2.5 FABRICATION

- A. **Sealed Insulating Glass Units:**
 - 1. Comply with ASTM E2190.
 - 2. Fabricate spacer bar frame of tubular aluminum filled with desiccant.
 - 3. Bond spacer bar frame to glass panes.
 - 4. Fill space outside frame to glass edge with elastomeric sealant.

PART 3 - EXECUTION

3.1 PREPARATION

- A. **Clean glazing rabbets;** remove loose and foreign matter.
- B. **Remove protective coatings** on metal surfaces.

- C. **Clean glass** just prior to installation.

3.2 INSTALLATION - GENERAL

- A. **Install glass** in accordance with glass manufacturer's instructions.
- B. **Maintain manufacturer's recommended edge and face clearances** between glass and frame members.

3.3 INSTALLATION - GASKET GLAZING METHOD

- A. **Fabricate gaskets** to fit openings; allow for stretching of gaskets during installation.
- B. **Set soft compression gasket** against fixed stop or frame with bonded miter cut joints at corners.
- C. **Set glass centered** in openings on setting blocks.
- D. **Install removable stops** and insert dense compression gaskets at corners, working toward centers of glass, compressing glass against soft compression gaskets to produce weathertight seal.
- E. **Seal joints** in gaskets.

3.4 INSTALLATION - SEALANT GLAZING METHOD

- A. **Apply sealant** to full depth of permanent stops.
- B. **Press glass** into sealant with slight lateral movement to ensure adhesion.
- C. **Apply sealant** to full depth of removable stops. Secure stops in position, forcing contact with sealant bead and completely filling joint.

3.5 PROTECTION

- A. **After installation**, mark glass with an 'X' using removable plastic tape.

3.6 SCHEDULE

- A. **Unit Configurations :**
 1. Outer lite: Nominally 1/4 inch-thick clear tempered glass.
 2. Airspace: 1 inch.
 3. Inner lite: Nominally 1/4 inch-thick clear tempered glass.

END OF SECTION

DIVISION 09 – FINISHES

Section 09 2216	Non-Structural Metal Framing
Section 09 2900	Gypsum Board
Section 09 3013	Ceramic Tile
Section 09 5100	Acoustical Ceilings
Section 09 6513	Resilient Wall Base and Accessories
Section 09 6516	Resilient Floor Coverings
Section 09 9100	Painting

THIS PAGE LEFT BLANK INTENTIONALLY

SECTION 09 2216

NON-STRUCTURAL METAL FRAMING

PART 1 - GENERAL

1.1 RELATED DOCUMENTS

- A. Drawings and general provisions of the Contract, including General and Supplementary Conditions and Division 1 Specification Sections, apply to this Section.

1.2 SUMMARY

- A. This **Section includes non-load-bearing steel framing** members for the following applications:
 - 1. Interior framing systems (e.g., supports for partition walls, framed soffits, furring, etc.).
 - 2. Interior suspension systems (e.g., supports for ceilings, suspended soffits, etc.).
- B. **Related Sections** include the following:
 - 1. Section 07 2116 "**Blanket Insulation**" for insulation installed in between framing members.

1.3 SUBMITTALS

- A. **Product Data:** For each type of product indicated.

1.4 QUALITY ASSURANCE

- A. **Fire-Test-Response Characteristics:** For fire-resistance-rated assemblies that incorporate non-load-bearing steel framing, provide materials and construction identical to those tested in assembly indicated according to ASTM E 119 by an independent testing agency.
- B. **STC-Rated Assemblies:** For STC-rated assemblies, provide materials and construction identical to those tested in assembly indicated according to ASTM E 90 and classified according to ASTM E 413 by an independent testing agency.
- C. **Design framing systems** in accordance with American Iron and Steel Institute Publication "S220 - North American Specification for the Design of Cold-Formed Steel Framing - Nonstructural Members", except as otherwise shown or specified.
- D. **Code-Compliance Certification of Studs and Tracks:** Provide documentation that framing members are certified according to the product-certification program of the Steel Framing Industry Association (SFIA) or be a part of a similar organization that provides verifiable code compliance program.

1.5 DELIVERY, STORAGE, AND HANDLING

- A. Protect cold-formed metal framing from corrosion, deformation, and other damage during delivery, storage, and handling as required by AISI's "Code of Standard Practice".

PART 2 - PRODUCTS

2.1 NON-LOAD-BEARING STEEL FRAMING, GENERAL

- A. **Framing Members, General:** Comply with ASTM C 645 for conditions indicated.
1. Steel Sheet Components: Comply with ASTM C 645 requirements for metal, unless otherwise indicated.
 2. Protective Coating: ASTM A 653, G40, Coating with equivalent corrosion resistance of ASTM A 653, G40 or [DiamondPlus®](#) coating; roll-formed from steel meeting mechanical and chemical requirements of ASTM A 1003 with a zinc-based coating. [G60]. Galvannealed products are not acceptable.
 - a. Coatings shall demonstrate equivalent corrosion resistance with an evaluation report acceptable to the authorities having jurisdiction.
- B. **Embossed Steel Studs and Tracks:** Studs which have been roll-formed and embossed with surface deformations to stiffen the framing members ("Viper" studs, etc.) shall **not** be used on this Project.

2.2 SUSPENSION SYSTEM COMPONENTS

- A. **Tie Wire:** ASTM A 641/A 641M, Class 1 zinc coating, soft temper, 16 gauge (0.0625-inch-) diameter wire, or double strand of 18 gauge (0.0475-inch) diameter wire.
- B. **Hanger Attachments to Concrete:**
1. Powder-Actuated Fasteners: Suitable for application indicated, fabricated from corrosion-resistant materials with clips or other devices for attaching hangers of type indicated, and capable of sustaining, without failure, a load equal to 10 times that imposed by construction as determined by testing according to ASTM E 1190 by an independent testing agency.
- C. **Wire Hangers:** ASTM A 641/A 641M, Class 1 zinc coating, soft temper, 0.162-inch diameter.
- D. **Flat Hangers:** Steel sheet, minimum 1 by 3/16 inch by length indicated.
- E. **Carrying Channels:** Cold-rolled, commercial-steel sheet with a base-steel thickness of 16 gauge (0.0538 inch) and minimum 1/2-inch- wide flanges.
1. Depth: Minimum 1-1/2 inches.
- F. **Furring Channels (Furring Members):**
1. Hat-Shaped, Rigid Furring Channels: ASTM C 645, 7/8 inch deep.
 - a. Minimum Base Steel Thickness: Minimum 20 gauge (0.0296 inch).
 2. Resilient Furring Channels: 1/2-inch- deep members designed to reduce sound transmission.
 - a. Equal to: [RC Deluxe \(RCSD\) Resilient Channel](#) by ClarkDietrich Building Systems or RSIC-1 as manufactured by PAC International, Inc.
- G. **Grid Suspension System for Ceilings:** ASTM C 645, direct-hung system composed of main beams and cross-furring members that interlock.
1. Available Products: Subject to compliance with requirements, products that may be incorporated into the Work include, but are not limited to, the following:
 - a. Armstrong World Industries, Inc.; Drywall Grid Systems.
 - b. Chicago Metallic Corporation.
 - c. USG Corporation; Drywall Suspension System.

2.3 STEEL FRAMING FOR FRAMED ASSEMBLIES

- A. **Steel Studs and Runners:** ASTM C 645.
1. Minimum Base-Steel Thickness: Minimum 20 gauge (30 mil or 0.0296 inch).
- B. **Slip-Type Head Joints:**
1. Deflection Track: Steel sheet top runner manufactured to prevent cracking of finishes applied to interior partition framing resulting from deflection of structure above; in thickness not less than indicated for studs and in width to accommodate depth of studs.
 - a. Available Products: Subject to compliance with requirements of Contract Documents, products that may be incorporated into the Work include, but are not limited to, the following:
 - 1) Steel Network Inc. (The); VertiClip SLD/VertiTrack VTD Series.
 - 2) ClarkDietrich Building Systems; [BlazeFrame DSL](#) [MaxTrak](#) Slotted Track.
- C. **Backing Plate: Proprietary fire-retardant-treated wood blocking and bracing in width indicated.**
1. Product: ClarkDietrich Building Systems; [Danback Fire-Retardant Treated Wood Backing Plate](#) [D16F] [D24F], or a comparable product.
- D. **Flat Strap Backing Plate:** Steel sheet for blocking and bracing in length and width indicated.
1. Minimum Base-Steel Thickness: Minimum 16 gauge.
- E. **Cold-Rolled Channel Bridging: 16 gauge** base-steel thickness, with minimum 1/2-inch wide flanges.
1. Product: ClarkDietrich Building Systems; [Cold-Formed U-Channel](#) and [EasyClip U-Series Angle](#) [U543] [U545] [U547], or a comparable product.
 2. Depth: Minimum 1-1/2 inches.
 3. Clip Angle: Not less than 1-1/2 by 1-1/2 inches, 16 gauge (0.0538 inch) thick, galvanized steel.
- F. **Hat-Shaped, Rigid Furring Channels:** ASTM C 645.
1. Minimum Base Steel Thickness: Minimum 20 Gauge (0.0296 inch).
 2. Depth: 7/8 inch.
- G. **Resilient Furring Channels:** 1/2-inch- deep, steel sheet members designed to reduce sound transmission.
1. Equal to: [RC Deluxe \(RCSD\) Resilient Channel](#) by ClarkDietrich Building Systems, or RSIC-1 as manufactured by PAC International, Inc.
- H. **Cold-Rolled Furring Channels:** 16 gauge (0.0538 inch) base-steel thickness, with minimum 1/2-inch- wide flanges.
1. Depth: Minimum 3/4 inch.
 2. Furring Brackets: Adjustable, corrugated-edge type of steel sheet with minimum base-steel thickness of 20 gauge (0.0296 inch).
 3. Tie Wire: ASTM A 641/A 641M, Class 1 zinc coating, soft temper, 0.062 inch diameter wire, or double strand of 0.0475-inch- diameter wire.
- I. **Z-Shaped Furring:** With slotted or nonslotted web, face flange of 1-1/4 inches wall attachment flange of 3/4 inch, minimum base-steel thickness of 25 gauge (0.0179 inch), and depth required to fit insulation thickness indicated.

2.4 AUXILIARY MATERIALS

- A. **General:** Provide auxiliary materials that comply with referenced installation standards.
 - 1. **Fasteners for Metal Framing:** Of type, material, size, corrosion resistance, holding power, and other properties required to fasten steel members to substrates.

- B. **Sill Sealer for Exterior Steel Stud Walls:** Provide a sill sealer equal to 'Triple Guard Energy Sill Sealer' as manufactured by 'Protecto Wrap'. Seal to have 3/8 inch thick rubberized adhesive membrane that forms an air/vapor moisture barrier system. The seal shall adhere to the face of the foundation, the top of the foundation wall and the face of the sill plate/skirt board.

PART 3 - EXECUTION

3.1 EXAMINATION

- A. **Examine areas and substrates,** with Installer present, and including welded hollow-metal frames, cast-in anchors, and structural framing, for compliance with requirements and other conditions affecting performance.
 - 1. Proceed with installation only after unsatisfactory conditions have been corrected.

3.2 INSTALLATION, GENERAL

- A. **Installation Standard:** ASTM C 754.
 - 1. **Gypsum Board Assemblies:** Also comply with requirements in ASTM C 840 that apply to framing installation.

- B. **Blocking:** Install supplementary framing, and blocking to support fixtures, equipment services, heavy trim, grab bars, toilet accessories, furnishings, cabinets and casework, or similar construction.

- C. **Bracing:** Install bracing at terminations in assemblies.

- D. **Expansion Joints:** Do not bridge building control and expansion joints with non-load-bearing steel framing members. Frame both sides of joints independently.

3.3 INSTALLING SUSPENSION SYSTEMS

- A. **Install suspension system** components in sizes and spacings indicated on Drawings, but not less than those required by referenced installation standards for assembly types and other assembly components indicated.

- B. **Isolate suspension systems** from building structure where they abut or are penetrated by building structure to prevent transfer of loading imposed by structural movement.

- C. **Suspend hangers from building structure as follows:**
 - 1. Install hangers plumb and free from contact with insulation or other objects within ceiling plenum that are not part of supporting structural or suspension system.
 - a. Splay hangers only where required to miss obstructions and offset resulting horizontal forces by bracing, countersplaying, or other equally effective means.

2. Where width of ducts and other construction within ceiling plenum produces hanger spacings that interfere with locations of hangers required to support standard suspension system members, install supplemental suspension members and hangers in the form of trapezes or equivalent devices.
 - a. Size supplemental suspension members and hangers to support ceiling loads within performance limits established by referenced installation standards.
 3. Wire Hangers: Secure by looping and wire tying, either directly to structures or to inserts, eye screws, or other devices and fasteners that are secure and appropriate for substrate, and in a manner that will not cause hangers to deteriorate or otherwise fail.
 4. Flat Hangers: Secure to structure, including intermediate framing members, by attaching to inserts, eye screws, or other devices and fasteners that are secure and appropriate for structure and hanger, and in a manner that will not cause hangers to deteriorate or otherwise fail.
 5. Do not attach hangers to steel roof deck.
 6. Do not attach hangers to permanent metal forms. Furnish cast-in-place hanger inserts that extend through forms.
 7. Do not attach hangers to rolled-in hanger tabs of composite steel floor deck.
 8. Do not connect or suspend steel framing from ducts, pipes, or conduit.
- D. **Fire-Resistance-Rated Assemblies:** Wire tie furring channels to supports.
- E. **Seismic Bracing:** Sway-brace suspension systems with hangers used for support.
- F. **Grid Suspension Systems:** Attach perimeter wall track or angle where grid suspension systems meet vertical surfaces. Mechanically join main beam and cross-furring members to each other and butt-cut to fit into wall track.
- G. **Installation Tolerances:** Install suspension systems that are level to within 1/8 inch in 12 feet measured lengthwise on each member that will receive finishes and transversely between parallel members that will receive finishes.

3.4 INSTALLING FRAMED ASSEMBLIES

- A. **Where studs are installed directly against exterior masonry walls** or dissimilar metals at exterior walls, install isolation strip between studs and exterior wall.
- B. **Install studs** so flanges within framing system point in same direction.
- C. **Install tracks** (runners) at floors and overhead supports. Extend framing full height to structural supports or substrates above suspended ceilings, except where partitions are indicated to terminate at suspended ceilings. Continue framing around ducts penetrating partitions above ceiling.
 1. Slip-Type Head Joints: Where framing extends to overhead structural supports, install to produce joints at tops of framing systems that prevent axial loading of finished assemblies.
 2. Door Openings: Screw vertical studs at jambs to jamb anchor clips on door frames; install runner track section (for cripple studs) at head and secure to jamb studs.
 - a. Install two studs at each jamb or provide 16 gauge studs at door openings, unless otherwise indicated.
 - b. Install cripple studs at head adjacent to each jamb stud, with a minimum 1/2-inch clearance from jamb stud to allow for installation of control joint in finished assembly.
 - c. Extend jamb studs through suspended ceilings and attach to underside of overhead structure.

3. Other Framed Openings: Frame openings other than door openings the same as required for door openings, unless otherwise indicated. Install framing below sills of openings to match framing required above door heads.
 4. Fire-Resistance-Rated Partitions: Install framing to comply with fire-resistance-rated assembly indicated and support closures and to make partitions continuous from floor to underside of solid structure.
 5. Sound-Rated Partitions: Install framing to comply with sound-rated assembly indicated.
 6. Curved Partitions:
 - a. Bend track to uniform curve and locate straight lengths so they are tangent to arcs.
 - b. Begin and end each arc with a stud, and space intermediate studs equally along arcs. On straight lengths of not less than 2 studs at ends of arcs, place studs 6 inches o.c.
- D. **Direct Furring:**
1. Attach to concrete or masonry with stub nails, screws designed for masonry attachment, or powder-driven fasteners spaced 24 inches on center
- E. **Z-Furring Members:**
1. Erect insulation (specified in Division 7 Section "Building Insulation") vertically and hold in place with Z-furring members spaced 24 inches on center
 2. Except at exterior corners, securely attach narrow flanges of furring members to wall with concrete stub nails, screws designed for masonry attachment, or powder-driven fasteners spaced 24 inches on center
 3. At exterior corners, attach wide flange of furring members to wall with short flange extending beyond corner; on adjacent wall surface, screw-attach short flange of furring channel to web of attached channel. At interior corners, space second member no more than 12 inches from corner and cut insulation to fit.
- F. **Tackable Surface:** Provide back to back pairs of studs at 48 inches on center, spaced symmetrically from the centerline of the wall. Stud pairs when not coincident with wall framing studs may be terminated and headered 6 inches above the ceiling.

END OF SECTION

THIS PAGE LEFT BLANK INTENTIONALLY

SECTION 09 2900

GYPSUM BOARD

PART 1 - GENERAL

1.1 RELATED DOCUMENTS

- A. Drawings and general provisions of the Contract, including General and Supplementary Conditions and Division 1 Specification Sections, apply to this Section.

1.2 SUMMARY

- A. **This Section includes** the following:
 - 1. Interior gypsum board.
 - 2. Glass mat tile backing panels - interior.
 - 3. Aluminum trim.
- B. **Related Sections** include the following:
 - 1. Section 05 5000 "**Metal Fabrications**" for metal mesh to be incorporated in walls for security.
 - 2. Section 07 9200 "**Joint Sealants**" for acoustical sealants installed in assemblies that incorporate gypsum board.
 - 3. Section 09 2216 "**Non-Load-Bearing Steel Framing**" for non-structural framing and suspension systems that support gypsum board.
 - 4. Section 09 9100 "**Painting**" for **primers** applied to gypsum board surfaces.

1.3 SUBMITTALS

- A. **Product Data:** For each type of product indicated.
- B. **Samples:** For the following products:
 - 1. Trim Accessories: Full-size sample in 12-inch- long length for each trim accessory indicated.

1.4 QUALITY ASSURANCE

- A. **Fire-Resistance-Rated Assemblies:** For fire-resistance-rated assemblies, provide materials and construction identical to those tested in assembly indicated according to ASTM E 119 by an independent testing agency.
- B. **STC-Rated Assemblies:** For STC-rated assemblies, provide materials and construction identical to those tested in assembly indicated according to ASTM E 90 and classified according to ASTM E 413 by an independent testing agency.

1.5 STORAGE AND HANDLING

- A. **Store materials** inside under cover and keep them dry and protected against damage from weather, condensation, direct sunlight, construction traffic, and other causes. Stack panels flat to prevent sagging.

1.6 PROJECT CONDITIONS

- A. **Environmental Limitations:** Comply with ASTM C 840 requirements or gypsum board manufacturer's written recommendations, whichever are more stringent.

- B. **Do not install interior products** until installation areas are enclosed and conditioned.
- C. **Do not install panels** that are wet, those that are moisture damaged, and those that are mold damaged.
 - 1. Indications that panels are wet or moisture damaged include, but are not limited to, discoloration, sagging, or irregular shape.
 - 2. Indications that panels are mold damaged include, but are not limited to, fuzzy or splotchy surface contamination and discoloration.

PART 2 - PRODUCTS

2.1 PANELS, GENERAL

- A. **Size:** Provide in maximum lengths and widths available that will minimize joints in each area and that correspond with support system indicated.

2.2 INTERIOR GYPSUM BOARD

- A. **General:** Complying with ASTM C 36/C 36M or ASTM C 1396/C 1396M, as applicable to type of gypsum board indicated and whichever is more stringent.
- B. **Available Manufacturers:** Subject to compliance with requirements of Contract Documents, manufacturers offering products that may be incorporated into the Work include, but are not limited to, the following:
 - 1. American Gypsum Co.
 - 2. CertainTeed America Inc.
 - 3. Georgia-Pacific Gypsum.
 - 4. National Gypsum Company.
 - 5. PABCO Gypsum.
 - 6. USG Corporation.
- C. **Type X:**
 - 1. Thickness: 5/8 inch.
 - 2. Long Edges: Tapered.

2.3 TILE BACKING PANELS

- A. **Available Manufacturers:** Subject to compliance with requirements of Contract Documents, available manufacturers include, but are not limited to, the following:
 - 1. "DensShield Tile Guard" by G-P Gypsum.
 - 2. "Fiberock Aqua-Tough Interior Panel" by USG Corporation.
- B. **Properties:** Glass-mat, water-resistant backer units.
 - 1. Comply with ASTM C 1178/C 1178M.
 - 2. Core: 5/8 inch, Type X.
 - 3. Provide glass-mat, water-resistant backing board wherever tile is applied to a stud wall.

2.4 TRIM ACCESSORIES

- A. **Interior Trim:** ASTM C 1047.
 - 1. Material: Galvanized or aluminum-coated steel sheet or rolled zinc.
 - a. Shapes:
 - 1) Cornerbead.
 - 2) Bullnose bead.

- 3) LC-Bead: J-shaped; exposed long flange receives joint compound.
 - 4) L-Bead: L-shaped; exposed long flange receives joint compound.
 - 5) U-Bead: J-shaped; exposed short flange does not receive joint compound.
 - 6) Expansion (control) joint.
 - 7) Curved-Edge Cornerbead: With notched or flexible flanges.
3. Material: Vinyl conforming to ASTM D-1784.
- a. Available Manufacturers include but are not limited to:
AMICO (Alabama Metal Industries Corporation); www.amico-lath.com
 - b. Shape: Zip Strip Bead.

2.5 JOINT TREATMENT MATERIALS

- A. **General:** Comply with ASTM C 475/C 475M.
- B. **Joint Tape:**
1. Interior Gypsum Wallboard: Paper.
 2. Glass-Mat Gypsum Sheathing Board: 10-by-10 glass mesh.
 3. Tile Backing Panels: As recommended by panel manufacturer.
- C. **Joint Compound for Interior Gypsum Wallboard:** For each coat use formulation that is compatible with other compounds applied on previous or for successive coats.
1. Prefilling: At open joints, rounded or beveled panel edges, and damaged surface areas, use setting-type taping compound.
 2. Embedding and First Coat: For embedding tape and first coat on joints, fasteners, and trim flanges, use setting-type taping compound.
 3. Fill Coat: For second coat, use drying-type, all-purpose compound.
 4. Finish Coat: For third coat, use drying-type, all-purpose compound.
- D. **Joint Compound for Tile Backing Panels:**
1. Glass-Mat, Water-Resistant Backing Panel: As recommended by backing panel manufacturer.

2.6 AUXILIARY MATERIALS

- A. **General:** Provide auxiliary materials that comply with referenced installation standards and manufacturer's written recommendations.
- B. **Laminating Adhesive:** Adhesive or joint compound recommended for directly adhering gypsum panels to continuous substrate.
1. Use adhesives that have a VOC content of 50 g/L or less when calculated according to 40 CFR 59, Subpart D (EPA Method 24).
- C. **Steel Drill Screws:** ASTM C 1002, unless otherwise indicated.
1. Use screws complying with ASTM C 954 for fastening panels to steel members from 0.033 to 0.112 inch thick.
 2. For fastening cementitious backer units, use screws of type and size recommended by panel manufacturer.
- D. **Acoustical Sealant:** As specified in **Division 7** Section "**Joint Sealants.**"
- E. **Thermal Insulation:** As specified in **Division 7** Section "**Building Insulation.**"

PART 3 - EXECUTION

3.1 EXAMINATION

- A. **Examine areas and substrates**, with Installer present, and including welded hollow-metal frames and framing, for compliance with requirements and other conditions affecting performance.
- B. **Examine panels before installation.** Reject panels that are wet, moisture damaged, and mold damaged.
- C. **Proceed with installation** only after unsatisfactory conditions have been corrected.

3.2 APPLYING AND FINISHING PANELS, GENERAL

- A. **Comply with ASTM C 840.**
- B. **Install ceiling panels** across framing to minimize the number of abutting end joints and to avoid abutting end joints in central area of each ceiling. Stagger abutting end joints of adjacent panels not less than one framing member.
- C. **Install panels with face side out.** Butt panels together for a light contact at edges and ends with not more than 1/16 inch of open space between panels. Do not force into place.
- D. **Locate edge** and end joints over supports, except in ceiling applications where intermediate supports or gypsum board back-blocking is provided behind end joints. Do not place tapered edges against cut edges or ends. Stagger vertical joints on opposite sides of partitions. Do not make joints other than control joints at corners of framed openings.
- E. **Form control and expansion joints** with space between edges of adjoining gypsum panels.
- F. **Cover both faces** of support framing with gypsum panels in concealed spaces (above ceilings, etc.), except in chases braced internally.
 - 1. Unless concealed application is indicated or required for sound, fire, air, or smoke ratings, coverage may be accomplished with scraps of not less than 8 sq. ft. in area.
 - 2. Fit gypsum panels around ducts, pipes, and conduits.
 - 3. Where partitions intersect structural members projecting below underside of floor/roof slabs and decks, cut gypsum panels to fit profile formed by structural members; allow 1/4- to 3/8-inch- wide joints to install sealant.
- G. **Isolate perimeter** of gypsum board applied to non-load-bearing partitions at structural abutments, except floors. Provide 1/4- to 1/2-inch- wide spaces at these locations, and trim edges with edge trim where edges of panels are exposed. Seal joints between edges and abutting structural surfaces with acoustical sealant.
- H. **Attachment to Steel Framing:** Attach panels so leading edge or end of each panel is attached to open (unsupported) edges of stud flanges first.

3.3 APPLYING INTERIOR GYPSUM BOARD

- A. **Install interior gypsum board** in the following locations:
1. Type X: Vertical surfaces, unless otherwise indicated.
- B. **Single-Layer Application:**
1. On ceilings, apply gypsum panels before wall/partition board application to greatest extent possible and at right angles to framing, unless otherwise indicated.
 2. On partitions/walls, apply gypsum panels horizontally (perpendicular to framing), unless otherwise indicated or required by fire-resistance-rated assembly, and minimize end joints.
 - a. Stagger abutting end joints not less than one framing member in alternate courses of panels.
 - b. At stairwells and other high walls, install panels horizontally, unless otherwise indicated or required by fire-resistance-rated assembly.
 3. On Z-furring members, apply gypsum panels vertically (parallel to framing) with no end joints. Locate edge joints over furring members.
 4. Fastening Methods: Apply gypsum panels to supports with steel drill screws.
- C. **Multilayer Application:**
1. On ceilings, apply gypsum board indicated for base layers before applying base layers on walls/partitions; apply face layers in same sequence. Apply base layers at right angles to framing members and offset face-layer joints 1 framing member, 16 inches minimum, from parallel base-layer joints, unless otherwise indicated or required by fire-resistance-rated assembly.
 2. On partitions/walls, apply gypsum board indicated for base layers and face layers vertically (parallel to framing) with joints of base layers located over stud or furring member and face-layer joints offset at least one stud or furring member with base-layer joints, unless otherwise indicated or required by fire-resistance-rated assembly. Stagger joints on opposite sides of partitions.
 3. On Z-furring members, apply base layer vertically (parallel to framing) and face layer either vertically (parallel to framing) or horizontally (perpendicular to framing) with vertical joints offset at least one furring member. Locate edge joints of base layer over furring members.
 4. Fastening Methods: Fasten base layers with screws; fasten face layers with adhesive and supplementary fasteners.
- D. **Laminating to Substrate:** Where gypsum panels are indicated as directly adhered to a substrate (other than studs, joists, furring members, or base layer of gypsum board), comply with gypsum board manufacturer's written recommendations and temporarily brace or fasten gypsum panels until fastening adhesive has set.

3.4 APPLYING TILE BACKING PANELS

- A. **Glass-Mat, Water-Resistant Backing Panel:** Comply with manufacturer's written installation instructions and install at locations indicated to receive tile. Install with 1/4-inch gap where panels abut other construction or penetrations.
- B. **Where tile backing panels abut other types of panels** in same plane, shim surfaces to produce a uniform plane across panel surfaces.

3.5 INSTALLING TRIM ACCESSORIES

- A. **General:** For trim with back flanges intended for fasteners, attach to framing with same fasteners used for panels. Otherwise, attach trim according to manufacturer's written instructions.
- B. **Control Joints:** Install control joints according to ASTM C 840 and in specific locations approved by Architect for visual effect.
- C. **Interior Trim:** Install in the following locations:
 - 1. Cornerbead: Use at outside corners, unless otherwise indicated.
 - 2. Bullnose Bead: Use where indicated.
 - 3. LC-Bead: Use at exposed panel edges.
 - 4. L-Bead: Use where indicated.
 - 5. U-Bead: Use at exposed panel edges.
- D. **Install corner beads** at external corners. Provide metal trim to protect edge of gypsum board wherever gypsum board intersects a dissimilar material. Hold channel and L trim back from metal window and door frames 1/8 inch to allow for caulking.

3.6 FINISHING GYPSUM BOARD

- A. **General:** Treat gypsum board joints, interior angles, edge trim, control joints, penetrations, fastener heads, surface defects, and elsewhere as required to prepare gypsum board surfaces for decoration. Promptly remove residual joint compound from adjacent surfaces.
- B. **Prefill open joints**, rounded or beveled edges, and damaged surface areas.
- C. **Apply joint tape** over gypsum board joints, except those with trim having flanges not intended for tape.
- D. **Gypsum Board Finish Levels:** Finish panels to levels indicated below:
 - 1. Level 1: Ceiling plenum areas, concealed areas, and where indicated.
 - 2. Level 2: Panels that are substrate for tile.
 - 3. Level 5: At all wall surfaces, except where noted otherwise above.
 - a. Primer and its application to surfaces are specified in other Division 9 Sections.
- E. **Glass-Mat, Water-Resistant Backing Panels:** Finish according to manufacturer's written instructions.

3.7 PROTECTION

- A. **Protect installed products** from damage from weather, condensation, direct sunlight, construction, and other causes during remainder of the construction period.
- B. **Remove and replace** panels that are wet, moisture damaged, and mold damaged.
 - 1. Indications that panels are wet or moisture damaged include, but are not limited to, discoloration, sagging, or irregular shape.
 - 2. Indications that panels are mold damaged include, but are not limited to, fuzzy or splotchy surface contamination and discoloration.

3.8 FIELD QUALITY CONTROL

- A. **Above-Ceiling Observation:** Architect will conduct an above-ceiling observation before installing gypsum board ceilings and report deficiencies in the Work observed. Do not proceed with installation of gypsum board to ceiling support framing until deficiencies have been corrected.
1. Notify Architect seven days in advance of date and time when Project, or part of Project, will be ready for above-ceiling observation.
 2. Before notifying Architect, complete the following in areas to receive gypsum board ceilings:
 - a. Installation of 80 percent of lighting fixtures, powered for operation.
 - b. Installation, insulation, and leak and pressure testing of water piping systems.
 - c. Installation of air-duct systems.
 - d. Installation of air devices.
 - e. Installation of mechanical system control-air tubing.
 - f. Installation of ceiling support framing.

END OF SECTION

THIS PAGE LEFT BLANK INTENTIONALLY

SECTION 09 3013

CERAMIC TILING

PART 1 - GENERAL

1.1 RELATED DOCUMENTS

- A. Drawings and general provisions of the Contract, including General and Supplementary Conditions and Division 1 Specification Sections, apply to this Section.

1.2 SUMMARY

- A. This **Section includes** the following:
 - 1. Porcelain mosaic floor tile.
 - 2. Porcelain floor and wall tile.
 - 3. Waterproofing for tile installations
 - 4. Thresholds installed as part of tile installations.
- B. **Related Sections** include the following:
 - 1. Section 07 9200 "**Joint Sealants**" for sealing of expansion, contraction, control, and isolation joints in tile surfaces.
 - 2. Section 09 2900 "**Gypsum Board**" for gypsum backer at ceramic tile installations.
 - 3. **Key-Finish on Drawings** listing styles, sizes, colors, and installation patterns.

1.3 DEFINITIONS

- A. **Module Size:** Actual tile size (minor facial dimension as measured per ASTM C 499) plus joint width indicated.
- B. **Facial Dimension:** Nominal tile size as defined in ANSI A137.1.

1.4 PERFORMANCE REQUIREMENTS

- A. **Static Coefficient of Friction:** For tile installed on walkway surfaces, provide products with the following values as determined by testing identical products per ASTM C 1028:
 - 1. Level Surfaces: Minimum 0.6.
- B. **Load-Bearing Performance:** For ceramic tile installed on walkway surfaces, provide installations rated for the following load-bearing performance level based on testing assemblies according to ASTM C 627 that are representative of those indicated for this Project:
 - 1. Heavy: Passes cycles 1 through 12.

1.5 SUBMITTALS

- A. **Product Data:** For each type of tile, mortar, grout, and other products specified.
- B. **Tile Samples for Selection:** Manufacturer's color charts consisting of actual tiles or sections of tiles showing the full range of colors, textures, and patterns available for each type and composition of tile indicated. Include Samples of accessories involving color selection.

- C. **Grout Samples for Selection:** Manufacturer's color charts consisting of actual sections of grout showing the full range of colors available for each type of grout indicated.

1.6 QUALITY ASSURANCE

- A. **Installer Qualifications:** Engage an experienced installer who has completed tile installations similar in material, design, and extent to that indicated for this Project and with a record of successful in-service performance.
- B. **Source Limitations for Tile:** Obtain each color, grade, finish, type, composition, and variety of tile from one source with resources to provide products from the same production run for each contiguous area of consistent quality in appearance and physical properties without delaying the Work.
- C. **Source Limitations for Setting and Grouting Materials:** Obtain ingredients of a uniform quality for each mortar, adhesive, and grout component from a single manufacturer and each aggregate from one source or producer.
- D. **Source Limitations for Other Products:** Obtain each of the following products specified in this Section from one source and by a single manufacturer for each product:
 - 1. Solid surface material thresholds.
 - 2. Waterproofing.

1.7 DELIVERY, STORAGE, AND HANDLING

- A. **Deliver and store** packaged materials in original containers with seals unbroken and labels intact until time of use. Comply with requirement of ANSI A137.1 for labeling sealed tile packages.
- B. **Prevent damage** or contamination to materials by water, freezing, foreign matter, and other causes.
- C. **Handle tile** with temporary protective coating on exposed surfaces to prevent coated surfaces from contacting backs or edges of other units. If coating does contact bonding surfaces of tile, remove coating from bonding surfaces before setting tile.

1.8 PROJECT CONDITIONS

- A. **Environmental Limitations:** Do not install tile until construction in spaces is completed and ambient temperature and humidity conditions comply with referenced standards and manufacturer's written instructions.

1.9 EXTRA MATERIALS

- A. **Deliver extra materials to Owner.** Furnish extra materials described below that match products installed, are packaged with protective covering for storage, and are identified with labels describing contents.
 - 1. **Tile and Trim Units:** Furnish quantity of full-size units equal to 3 percent of amount installed, for each type, composition, color, pattern, and size indicated.

PART 2 - PRODUCTS

2.1 MANUFACTURERS

- A. **Manufacturers:** Subject to compliance with requirements of Contract Documents, provide products by manufacturers listed below and as indicated in Key-Finish on Drawings. Substitutions will not be considered.
1. Tile Products:
 - a. Daltile Tile Company.
 - B Interstyle.
 2. Tile-Setting and -Grouting Materials:
 - a. Mapei

2.2 PRODUCTS, GENERAL

- A. **ANSI Ceramic Tile Standard:** Provide tile that complies with ANSI A137.1, "Specifications for Ceramic Tile," for types, compositions, and other characteristics indicated.
1. Provide tile complying with Standard Grade requirements, unless otherwise indicated.
 2. For facial dimensions of tile, comply with requirements relating to tile sizes specified in Part 1 "Definitions" Article.
- B. **ANSI Standards for Tile Installation Materials:** Provide materials complying with ANSI standards referenced in "Setting Materials" and "Grouting Materials" articles.
- C. **Colors, Textures, and Patterns:** Where manufacturer's standard products are indicated for tile, grout, and other products requiring selection of colors, surface textures, patterns, and other appearance characteristics, provide specific products or materials complying with the following requirements:
1. Provide Architect's selections from manufacturer's full range of colors, textures, and patterns for products of type indicated. Refer to the Key-Finish Schedule.
 2. Provide tile trim and accessories that match color and finish of adjoining flat tile.
- D. **Factory Blending:** For tile exhibiting color variations within the ranges selected during Sample submittals, blend tile in the factory and package so tile units taken from one package show the same range in colors as those taken from other packages and match approved Samples.
- E. **Mounting:** Where factory-mounted tile is required, provide back- or edge-mounted tile assemblies as standard with manufacturer, unless another mounting method is indicated.
1. Where tile is indicated for installation in wet areas, do not use back- or edge-mounted tile assemblies unless tile manufacturer specifies in writing that this type of mounting is suitable for these kinds of installations and has a record of successful in-service performance.
- F. **Factory-Applied Temporary Protective Coating:** Where indicated under tile type, protect exposed surfaces of tile against adherence of mortar and grout by precoating them with a continuous film of petroleum paraffin wax, applied hot. Do not coat unexposed tile surfaces.

2.3 TILE PRODUCTS

- A. **Mosaic Porcelain Tile (F9):** Provide factory mounted colorbody flat tile complying with the following requirements:
1. Module Sizes: As indicated on Key-Finish.
 2. Nominal Thickness: 1/4 inch.
 3. Face: Unpolished, with square edges.
 4. Colors: As listed in the Key-Finish.
- B. **Glazed Ceramic Wall Tile (T1):** Provide flat tile complying with the following requirements:
1. Module Size: 3 x 6 inches.
 2. Nominal Thickness: 5/16 inches.
 3. Face: Plain with cushion edges.
 4. Colors: As listed in the Key-Finish.
- D. **Glass Wall Tile (T2):** Provide flat tile complying with the following requirements:
1. Module Size: 1 x 6 inches.
 2. Nominal Thickness: 5/16 inches.
 3. Face: Plain with cushion edges.
 4. Colors: As listed in the Key-Finish.
- D/ **Trim Units:** Provide tile trim units to match characteristics of adjoining flat tile and to comply with the following requirements:
1. Size: As indicated, coordinated with sizes and coursing of adjoining flat tile where applicable.
 2. Shapes: As follows, selected from manufacturer's standard shapes:
 - a. Base for Portland Cement Mortar Installations: Coved, flush.
 - b. Base for Thin-Set Mortar Installations: As shown on Drawings.
 - c. Wainscot Cap for Thin-Set Mortar Installations: Surface bullnose.
 - d. External Corners for Thin-Set Mortar Installations: Surface bullnose.
 - e. Internal Corners: Field-buttet square corners, except with coved base and cap angle pieces designed to member with stretcher shapes.

2.4 METAL TRIMS

- A. **Basis of Design:** Contract Documents are based on products specified below to establish a standard of quality. Other manufacturers offering products with equivalent characteristics may be considered, provided deviations are minor and design concept as expressed in the Contract Documents is not changed, as judged by the Architect.
1. Manufacturer: Schluter Systems LP
 2. Products: As listed in the Key-Finish Schedule on Drawings or, if not listed, as selected by Architect from manufacturer's full range
- B. **Finish:** Clear anodized aluminum.

2.5 WATERPROOFING AND CRACK ISOLATION MEMBRANE

- A. **Membrane:** Apply in areas which may have water on floor, including, but not limited to, restrooms, breakrooms, lab spaces, clean and soiled utility, janitor's closets, etc. and where designated on Drawings.

- B. **Available Manufacturers:** Subject to compliance with requirements, manufacturers offering products that may be incorporated into the Work include but are not limited to the following:
1. Manufacturer: Mapei.
 2. Product: Mapeguard UM.
- C. **Industry Standards and Approvals:**
1. ASTM C627 (Robinson): Extra Heavy Rating.
 2. ANSI: Exceeds A118.10 (Waterproofing Membrane for Thin-Set Ceramic Tile)
 3. ANSI: A118.12, Section 5.1.3 – Achieves bond strength of 50 psi or greater in 7 days per test method.
 4. ANSI: A118.12, Section 5.2.3 – Passes. Point load resistance after 28-day cure.
- D. **Properties:**
1. Compressive Strength: 0.37 N/mm².
 2. Permeance: <0.07.
 3. Material Thickness: 1/64 inch, nominal.
 4. Membrane Height: 1/8 inch, nominal.
 5. Waterproofing Tape: Mapeguard ST, applied in accordance with manufacturer's written instructions; flood test before applying tile.

2.6 THRESHOLDS

- A. **General:** Provide thresholds that are uniform in color and finish, fabricated to sizes and profiles indicated to provide transition between tile surfaces and adjoining finished floor surfaces.
1. **Bevel edges** at 1:2 slope, with lower edge of bevel aligned with or up to 1/16 inch above adjacent floor surface. Finish bevel to match top surface of threshold. Limit height of threshold to 1/2 inch or less above adjacent floor surface.
- B. **Molded Thresholds:**
1. Available Products: Subject to compliance with requirements of Contract Documents, products that may be incorporated in the Work include, but are not limited to, the following:
 - a. Corian; DuPont Polymers.
 - b. Solid Surfacing; Formica Corporation.
 - c. Staron; Lotte Advanced Materials.
 2. Solid Surfacing Material: Homogeneous solid sheets of filled plastic resin complying with the material and performance requirements of ANSI Z124.3, Type 5 or Type 6, without a pre-coated finish.
 - a. Thresholds shall be minimum 1/2 inch thick.
 - b. Provide tapered front edge.
 - c. Thresholds shall be continuous between door jambs.
 - d. Provide colors as selected by Architect from manufacturer's full selection of colors

2.7 SETTING MATERIALS

- A. **Polymer-Modified Thinset Mortar:** Meet or exceed ANSI A118.4, A118.11, A118.15E and ISO C2ES1P1.
1. Basis of Design: Contract Documents are based on product specified below to establish a standard of quality. Other manufacturers with products having equivalent characteristics may be considered, provided deviations are minor and design concept as expressed in the Contract Documents is not changed, as judged by the Architect.
 - a. Manufacturer: Mapei; www.mapei.com
 - b. Product: "UltraFlex 3".
 2. Protection:
 - a. Install only at temperatures between 40 degrees F and 95 degrees F.
 - b. Protect from traffic for 24 hours. Protect from heavy traffic for 7 days.
 - c. Protect from frost and rain for 21 days.
 - d. Protect from water immersion for 21 days.
- B. **Polymer-Enriched Large and Heavy Tile Mortar:** A118.4HTE, A118.11 and A118.15HTE.
1. Basis of Design: Contract Documents are based on product specified below to establish a standard of quality. Other manufacturers with products having equivalent characteristics may be considered, provided deviations are minor and design concept as expressed in the Contract Documents is not changed, as judged by the Architect.
 - a. Manufacturer: Mapei; www.mapei.com
 - b. Product: "Large Tile and Stone Mortar".
 2. Protection:
 - a. Do not disturb the installation, allow light traffic or grout the tiles for at least 24 to 48 hours.
 - b. Protect the installation from general traffic for at least 72 hours and from heavy traffic for at least 7 days.
 - c. Protect the installation from rain for 72 hours and from freezing for 21 days.
- C. **Thick-Set Mortar:** ANSI A108.1A; p
1. Basis of Design: Contract Documents are based on product specified below to establish a standard of quality. Other manufacturers with products having equivalent characteristics may be considered, provided deviations are minor and design concept as expressed in the Contract Documents is not changed, as judged by the Architect.
 - a. Manufacturer: Mapei; www.mapei.com
 - b. Product: "Modified Mortar Bed".
 2. Properties: Pre-blended cement-based, polymer-modified thick bed mortar.
 3. Protection:
 - a. Provide for dry, heated storage on site and deliver materials at least 24 hours before work begins.
 - b. Protect the installation from rain, snow, freezing and direct solar heat, which may affect curing and performance properties.
 - c. Maintain a temperature between 45 degrees F and 95 degrees F for at least 72 hours after the installation.
 - d. Because temperature and humidity (during and after installation of tile) affect the final curing time, allow for extended periods of protection when jobsite temperatures drop below 60 degrees F and/or when relative humidity is higher than 70 percent.
 - e. If Modified Mortar Bed is being used to install tile, allow it to cure for 24 hours per 1/2 inch of thickness. Curing time depends upon thickness applied and jobsite conditions.

- f. When installing per ANSI A108.1B, cover the mortar bed for an initial 24 hours.

2.8 GROUTING MATERIALS

- A. **Latex-Portland Cement Grout:** Meets or exceeds ANSI A118.3 and A118.6.
 - 1. **Basis of Design:** Basis of Design: Contract Documents are based on product specified below to establish a standard of quality. Other manufacturers with products having equivalent characteristics may be considered, provided deviations are minor and design concept as expressed in the Contract Documents is not changed, as judged by the Architect.
 - a. **Manufacturer:** Mapei; www.mapei.com
 - b. **Product:** Mapei Flexcolor CQ.
 - 2. **Protection:**
 - a. Use only at temperatures between 50 degrees F and 95 degrees F.
 - b. Provide for dry, heated storage on site and deliver materials at least 24 hours before tilework begins.
 - c. For at least 72 hours after completion, protect from rain and freezing, and do not immerse the installation in water.
 - d. **Floors:** Keep the installation free from foot traffic for at least 24 hours after grouting.
 - e. **Walls:** Protect the installation from impact, vibration and hammering on adjacent and opposite walls for 14 days after tile installation (see the TDS of the adhesive or setting system for details).
 - f. Because temperature and humidity (during and after installation of tile) affect the final curing time of all cement-based materials, allow for extended periods of curing and protection when temperatures drop below 60 degrees F or when the relative humidity is higher than 70 percent.
 - 3. **Colors:** As indicated on Finish Legend or, if not indicated, as selected by Architect from manufacturer's full range of colors.

2.9 ELASTOMERIC SEALANTS

- A. **General:** Provide manufacturer's standard chemically curing, elastomeric sealants of base polymer and characteristics indicated that comply with applicable requirements of Division 7 Section "Joint Sealants."
- B. **Colors:** Provide colors of exposed sealants to match colors of grout in tile adjoining sealed joints, unless otherwise indicated.
- C. **One-Part, Mildew-Resistant Silicone Sealant:** ASTM C 920; Type S; Grade NS; Class 25; Uses NT, G, A, and, as applicable to nonporous joint substrates indicated, O; formulated with fungicide, intended for sealing interior ceramic tile joints and other nonporous substrates that are subject to in-service exposures of high humidity and temperature extremes.
- D. **Multipart, Pourable Urethane Sealant for Use T:** ASTM C 920; Type M; Grade P; Class 25; Uses T, M, A, and, as applicable to joint substrates indicated, O.

- E. **Available Products:** Subject to compliance with requirements of Contract Documents, products which may be incorporated into the Work include, but are not limited to, the following:
1. **One-Part, Mildew-Resistant Silicone Sealants:**
 - a. Dow Corning 786; Dow Corning Corporation.
 - b. Sanitary 1700; GE Silicones.
 - c. Pecora 898 Sanitary Silicone Sealant; Pecora Corp.
 - d. Tremsil 600 White; Tremco, Inc.
 2. **Multipart, Pourable Urethane Sealants:**
 - a. Chem-Calk 550; Bostik.
 - b. Vulkem 245; Mameco International, Inc.
 - c. NR-200 Urexpan; Pecora Corp.
 - d. THC-900; Tremco, Inc.

2.10 MISCELLANEOUS MATERIALS

- A. **Trowelable Underlayments and Patching Compounds:** Latex-modified, Portland-cement-based formulation provided or approved by manufacturer of tile-setting materials for installations indicated.
- B. **Temporary Protective Coating:** Provide product indicated below that is formulated to protect exposed surfaces of tile against adherence of mortar and grout; is compatible with tile, mortar, and grout products; and is easily removable after grouting is completed without damaging grout or tile.
1. Petroleum paraffin wax, fully refined and odorless, containing at least 0.5 percent oil with a melting point of 120 to 140 degrees F per ASTM D 87.
- C. **Tile Cleaner:** A neutral cleaner capable of removing soil and residue without harming tile and grout surfaces, specifically approved for materials and installations indicated by tile and grout manufacturers.
- D. **Grout Sealer:** Solvent-based, no-sheen, natural-look penetrating sealer for all sanded and non-sanded grout joints.

2.11 MIXING MORTARS AND GROUT

- A. **Mix mortars** and grouts to comply with referenced standards and mortar and grout manufacturers' written instructions.
- B. **Add materials and additives in accurate proportions.** Do not use or add any water to mortar or grout when mixing, use only latex additive.
- C. **Obtain and use type of mixing equipment,** mixer speeds, mixing containers, mixing time, and other procedures to produce mortars and grouts of uniform quality with optimum performance characteristics for installations indicated.

PART 3 - EXECUTION

3.1 EXAMINATION

- A. **Examine substrates**, areas, and conditions where tile will be installed, with Installer present, for compliance with requirements for installation tolerances and other conditions affecting performance of installed tile.
 - 1. Verify that substrates for setting tile are firm; dry; clean; free from oil, waxy films, and curing compounds; and within flatness tolerances required by referenced ANSI A108 series of tile installation standards for installations indicated.
 - 2. Verify that installation of grounds, anchors, recessed frames, electrical and mechanical units of work, and similar items located in or behind tile has been completed before installing tile.
 - 3. Verify that joints and cracks in tile substrates are coordinated with tile joint locations; if not coordinated, adjust latter in consultation with Architect.
- B. **Do not proceed** with installation until unsatisfactory conditions have been corrected.

3.2 PREPARATION

- A. **Remove coatings**, including curing compounds, and other substances that contain soap, wax, oil, or silicone and are incompatible with tile-setting materials by using a terrazzo or concrete grinder, a drum sander, or a polishing machine equipped with a heavy-duty wire brush.
- B. **Provide concrete substrates** for tile floors installed with dry-set or latex-Portland cement mortars that comply with flatness tolerances specified in referenced ANSI A108 series of tile installation standards for installations indicated.
 - 1. Use trowelable leveling and patching compounds per tile-setting material manufacturer's written instructions to fill cracks, holes, and depressions.
 - 2. Remove protrusions, bumps, and ridges by sanding or grinding.
- C. **Blending:** For tile exhibiting color variations within the ranges selected during Sample submittals, verify that tile has been blended in the factory and packaged so tile units taken from one package show the same range in colors as those taken from other packages and match approved Samples. If not factory blended, either return to manufacturer or blend tiles at Project site before installing.
- D. **Field-Applied Temporary Protective Coating:** Where indicated under tile type or needed to prevent adhesion or staining of exposed tile surfaces by grout, protect exposed surfaces of tile against adherence of mortar and grout by pre-coating them with a continuous film of temporary protective coating indicated below, taking care not to coat unexposed tile surfaces:
 - 1. Petroleum paraffin wax, applied hot.

3.3 INSTALLATION, GENERAL

- A. **ANSI Tile Installation Standards:** Comply with parts of ANSI A108 series of tile installation standards in "Specifications for Installation of Ceramic Tile" that apply to types of setting and grouting materials and to methods indicated in ceramic tile installation schedules.
- B. **TCNA Installation Guidelines:** TCNA's "Handbook for Ceramic Tile Installation." Comply with TCNA installation methods indicated in ceramic tile installation schedules.

- C. **Extend tile work into recesses** and under or behind equipment and fixtures to form a complete covering without interruptions, unless otherwise indicated. Terminate work neatly at obstructions, edges, and corners without disrupting pattern or joint alignments.
- D. **Accurately form intersections and returns.** Perform cutting and drilling of tile without marring visible surfaces. Carefully grind cut edges of tile abutting trim, finish, or built-in items for straight aligned joints. Fit tile closely to electrical outlets, piping, fixtures, and other penetrations so plates, collars, or covers overlap tile.
- E. **Jointing Pattern:** Lay tile in grid pattern, unless otherwise indicated. Align joints when adjoining tiles on floor, base, walls, and trim are the same size. Lay out tile work and center tile fields in both directions in each space or on each wall area. Adjust to minimize tile cutting. Provide uniform joint widths, unless otherwise indicated.
 - 1. For tile mounted in sheets, make joints between tile sheets the same width as joints within tile sheets so joints between sheets are not apparent in finished work.
- F. **Lay out tile wainscots** to next full tile beyond dimensions indicated.
- G. **Expansion Joints:** Locate expansion joints and other sealant-filled joints, including control, contraction, and isolation joints, where indicated or if not indicated as recommended by TCNA guidelines, during installation of setting materials, mortar beds, and tile. Do not saw-cut joints after installing tiles.
 - 1. Locate joints in tile surfaces directly above joints in concrete substrates.
 - 2. Prepare joints and apply sealants to comply with requirements of Division 7 Section "Joint Sealants."
- H. **Grout tile to comply** with the requirements of the following tile installation standards:
 - 1. For ceramic tile grouts (sand-Portland cement, dry-set, commercial Portland cement, and latex-Portland cement grouts), comply with ANSI A108.10.

3.4 FLOOR TILE INSTALLATION

- A. **General:** Install tile to comply with requirements in the Ceramic Tile Floor Installation Schedule, including those referencing TCNA installation methods and ANSI A108 series of tile installation standards.
 - 1. **Movement Joints:** Provide movement joints as recommended by TCNA EJ171-09 "Movement Joint Design Essentials". Space joints as indicated on the drawings, if not shown on the drawings space joints as recommended by TCNA guidelines. Coordinate with the Architect for precise location of joints, locate joints as follows:
 - a. Interior: Space joints not greater than 20 feet in each direction interior spaces.
 - b. Exterior or interior exposed to direct sunlight: Space joints not greater than 8 feet in each direction.
 - c. Provide joints where tilework abuts restraining surfaces such as perimeter walls, dissimilar floors, curbs, columns, pipes, ceilings and where changes occur in backing materials. Not at drain strainers.
 - d. Provide joints where the following conditions exist: at all expansion, control, construction, cold and seismic joints, including such conditions at vertical surfaces.
 - 2. **Installation Methods:**
 - a. Tile over Concrete Surfaces: TCNA F125-FULL.

- B. **Joint Widths:** Install tile on floors with the following joint widths:
 - 1. Porcelain Mosaic Tile: 1/8 inch or as recommended by tile manufacturer.
 - 2. Ceramic Mosaic Tile: 1/16 inch or as recommended by tile manufacturer.
 - 3. Ceramic Tile: 1/16 inch or as recommended by tile manufacturer.

- C. **Back Buttering:** For installations indicated, obtain 100 percent mortar coverage by complying with applicable special requirements for back buttering of tile in referenced ANSI A108 series of tile installation standards:
 - 1. Tile floors composed of tiles 8 by 8 inches or larger.
 - 2. Tile floors installed with chemical-resistant grouts.

- D. **Thresholds:** Install thresholds at locations indicated; set in same type of setting bed as abutting field tile, unless otherwise indicated.
 - 1. Set thresholds in latex-Portland cement mortar for locations where mortar bed would otherwise be exposed above adjacent non-tile floor finish.

- E. **Apply two (2) coats of grout sealer** in accordance with manufacturer's printed instructions and recommendations. Remove sealer remaining on the tile within 3 to 5 minutes of application.

3.5 WALL TILE INSTALLATION

- A. **Install** types of tile designated for wall installations to comply with requirements in the Ceramic Tile Wall Installation Schedule, including those referencing TCNA installation methods and ANSI setting-bed standards.
 - 1. Installation Methods:
 - a. Tile over glass mat tile backer panels - Interior Surfaces: TCNA W244C.

- B. **Joint Widths:** Install tile on walls with the following joint widths:
 - 1. Ceramic Tile: 1/16 inch or as recommended by tile manufacturer.
 - 2. Wall Tile: 1/16 inch or as recommended by tile manufacturer.

- C. **Back Buttering:** For installations indicated, obtain 100 percent mortar coverage by complying with applicable special requirements for back buttering of tile in referenced ANSI A108 series of tile installation standards:
 - 1. Tile wall installations in wet areas, including showers.
 - 2. Tile wall installations composed of tiles 8 by 8 inches or larger.

- D. **Apply two (2) coats of grout sealer** in accordance with manufacturer's printed instructions and recommendations. Remove sealer remaining on the tile within 3 to 5 minutes of application.

3.6 CLEANING AND PROTECTING

- A. **Cleaning:** On completion of placement and grouting, clean all ceramic tile surfaces so they are free of foreign matter.
 - 1. Remove latex-Portland cement grout residue from tile as soon as possible.
 - 2. Unglazed tile may be cleaned with acid solutions only when permitted by tile and grout manufacturer's written instructions, but no sooner than 10 days after installation. Protect metal surfaces, cast iron, and vitreous plumbing fixtures from effects of acid cleaning. Flush surface with clean water before and after cleaning.
 - 3. Remove temporary protective coating by method recommended by coating manufacturer that is acceptable to brick and grout manufacturer. Trap and remove coating to prevent it from clogging drains.

- B. **Finished Tile Work:** Leave finished installation clean and free of cracked, chipped, broken, unbonded, and otherwise defective tile work.
- C. **Provide final protection** and maintain conditions, in a manner acceptable to manufacturer and Installer, which ensure tile is without damage or deterioration at the time of Substantial Completion.
- D. **When recommended by tile manufacturer,** apply a protective coat of neutral protective cleaner to completed tile walls and floors. Protect installed tile work with kraft paper or other heavy covering during construction period to prevent staining, damage, and wear.
- E. **Prohibit foot and wheel traffic** from tiled floors for at least 7 days after grouting is completed.
- F. **Before final inspection,** remove protective coverings and rinse neutral cleaner from tile surfaces.

END OF SECTION

SECTION 09 5100

ACOUSTICAL CEILINGS

PART 1 - GENERAL

1.1 RELATED DOCUMENTS

- A. Drawings and general provisions of Contract, including General and Supplementary Conditions and Division-1 Specification sections, apply to work of this section.

1.2 SUMMARY

- A. **Section includes** acoustical ceiling tile, suspension system and accessories.

1.3 SUBMITTALS

- A. **Product Data:** Manufacturer's product specifications and installation instructions for each acoustical ceiling material required, and for each suspension system, including certified laboratory test reports and other data as required to show compliance with these specifications.
 - 1. Include manufacturer's recommendations for cleaning and refinishing acoustical units, including precautions against materials and methods which may be detrimental to finishes and acoustical performances.
- B. **Samples:** Set of 6 inch x 4 inch square samples for each acoustical unit required, showing full range of exposed color and texture to be expected in completed work.
 - 1. Set of 12 inch long samples of each exposed runner and molding.

1.4 QUALITY ASSURANCE

- A. **Source Limitations:**
 - 1. Acoustical Ceiling Panel: Obtain each type through one source from a single manufacturer.
 - 2. Suspension System: Obtain each type through one source from a single manufacturer.
- B. **Fire Performance Characteristics:** Provide acoustical ceiling components that are identical to those tested for the following fire performance characteristics, according to ASTM test method indicated, by UL or other testing and inspecting agency acceptable to authorities having jurisdiction. Identify acoustical ceiling components with appropriate marking of applicable testing and inspecting agency.
 - 1. Surface Burning Characteristics: As follows, tested per ASTM E 84.
 - a. Flame Spread: 25 or less.
 - b. Smoke Developed: 50 or less.
 - 2. Fire Resistance Ratings: As indicated by reference to design designation in UL "Fire Resistance Directory" or "FM Approval Guide", for floor, roof or beam assemblies in which acoustical ceilings function as a fire protective membrane; tested per ASTM E 119. Provide protection materials for lighting fixtures and air ducts to comply with requirements indicated for rated assembly.
- C. **Seismic Standard:** Provide acoustical panel ceilings designed and installed to withstand the effects of earthquake motions according to the following:
 - 1. CISCA's Guidelines for Systems Requiring Seismic Restraint: Comply with CISCA's "Guidelines for Seismic Restraint of Direct-Hung Suspended Ceiling Assemblies--Seismic Zones 3 & 4."

- D. **Coordination of Work:** Coordinate layout and installation of acoustical ceiling units and suspension system components with other work supported by or penetrating through, ceilings, including light fixtures, HVAC equipment, fire-suppression system components (if any), and partition system (if any).

1.5 DELIVERY, STORAGE, AND HANDLING

- A. **Deliver acoustical ceiling units** to Project site in original, unopened packages and store them in a fully enclosed space where they will be protected against damage from moisture, direct sunlight, surface contamination or other causes.
- B. **Before installing acoustical ceiling units**, permit them to reach room temperature and a stabilized moisture content.
- C. **Handle acoustical ceiling units carefully** to avoid chipping edges or damaging units in any way.

1.6 PROJECT CONDITIONS

- A. **Space Enclosure:** Do not install interior acoustical ceilings until space is enclosed and weatherproof, wet-work in space is completed and nominally dry, work above ceilings completed, and ambient conditions of temperature and humidity will be continuously maintained at values near those indicated for final occupancy

1.7 COORDINATION

- A. **Coordinate layout and installation** of acoustical panels and suspension system with other construction that penetrates ceilings or is supported by them, including light fixtures, HVAC equipment, fire suppression system, and partition assemblies

1.8 EXTRA MATERIALS

- A. Furnish extra materials described below that match products installed and that are packaged with protective covering for storage and identified with labels describing contents.
 - 1. Acoustical Ceiling Panels: Full-size equal to 2.0 percent of quantity installed.
 - 2. Suspension System Components: Quantity of each exposed component equal to 2.0 percent of quantity installed.
 - 3. Hold-Down Clips: Equal to 2.0 percent of amount installed.

PART 2 - PRODUCTS

2.1 MANUFACTURER

- A. **Available Manufacturers:** Subject to compliance with requirements of Contract Documents, provide products listed below and as indicated in Key-Finish on Drawings. Substitutions will not be considered.
 - 1. Suspension System: Armstrong; Prelude XL 15/16 inch Exposed Tee.
 - 2. Acoustical Tile: Armstrong; Ultima 1910 and 1913
 - 3. Wood Plank: Armstrong Woodworks Linear Veneered Planks 6660W1
 - 4. Acoustical Sealant:
 - a. Tremco Acoustical Sealant; Tremco.
 - b. USG Acoustical Sealant; United States Gypsum Co.
 - c. Chem-Calk 600; Woodmont Products, Inc.
 - d. Pecora Corp; AC 20 FTR Acoustical and Insulation Sealant

2.2 MATERIALS

A. Acoustical Ceiling Units:

1. General: Provide manufacturer's standard units of configuration indicated which are prepared for mounting method designated and which comply with FS SS-S-118 requirements, including those indicated by reference to type, form, pattern, grade (NRC or NIC's as applicable), light reflectance coefficient (LR), edge detail, and joint detail (if any).
2. Mounting Method for Measuring NRC: No. 7 (mechanically mounted on special metal support), FS SS-S-118; or Type E-400 mounting as per ASTM E 795.
3. Sound Attenuation Performance: Provide acoustical ceiling units with ratings for ceiling sound transmission class (STC) of range indicated as determined according to AMA 1-II "Ceiling Sound Transmission Test by Two-Room Method" with ceilings continuous at partitions and supported by a metal suspension system of type appropriate for ceiling unit of configuration indicated (concealed for tile, exposed for panels).

B. Ceiling Types:

1. Type A: Armstrong: Ultima (1910)
 - a. Size: 24 inches x 24 inches x 3/4 inch
 - b. Edge: Square lay-In
 - c. CAC: 35
 - d. LR: 0.88
 - e. NRC: 0.75
 - f. ASTM E1264 Classification: Type IV, Form 2, Pattern E
 - g. Surface Finish: Scrim with factory-applied latex paint
2. Type B: Armstrong: Ultima (1913)
 - a. Size: 24 inches x 48 inches x 3/4 inch
 - b. Edge: Square lay-In
 - c. CAC: 35
 - d. LR: 0.88
 - e. NRC: 0.75
 - f. ASTM E1264 Classification: Type IV, Form 2, Pattern E
 - g. Surface Finish: Factory-applied vinyl latex paint
3. Type C: Suspended gypsum system; refer to Division 9 Section "Gypsum Board".
4. Type D: Painted, exposed structure.

C. Metal Suspension System: Provide metal suspension systems of type, structural classification and finish indicated which comply with applicable ASTM C 635 requirements.

1. Finishes and Colors: Provide manufacturer's standard finish for type of system indicated, unless otherwise required. For exposed suspension members and accessories with painted finish, provide color indicated or, if not otherwise indicated, as selected by Architect from manufacturer's full range of standard colors.
2. Attachment Devices: Size for 5 times design load indicated in ASTM C 635, Table 1, Direct Hung.
3. Hanger Wire: Galvanized carbon steel wire, ASTM A 641, soft temper, pre-stretched, Class 1 coating, sized so that stress at 3- times hanger design load (ASTM C 635, Table 1, Direct Hung), will be less than yield stress of wire, but provide not less than 12 gage.

4. Sheet-Metal Edge Moldings and Trim: Type and profile indicated or, if not indicated, manufacturer's standard moldings for edges and penetrations that fit acoustical panel edge details and suspension systems indicated; formed from sheet metal of same material and finish as that used for exposed flanges of suspension system runners.
 - a. For circular penetrations of ceiling, provide edge moldings fabricated to diameter required to fit penetration exactly.
 5. Hold-Down Clips: Minimum 24-gauge spring steel, 1-7/16 inches deep x 7/8 inches wide, designed to fit over cross tees. Provide clips spaced symmetrically 2 ft. o.c.
 6. Seismic Struts: Manufacturer's standard compression struts designed to accommodate seismic forces; locate at 12 feet on center both ways for suspended ceilings according to UBC Standard 25-2 other standard required by authority having jurisdiction.
 - a. In lieu of compression struts, provide a seismic clip with an ES Report number from ICC demonstrating that the compression struts and the 2-inch perimeter wall mold are not required.
 1. BERC seismic clips; Armstrong.
 2. 1496 Perimeter Clip; Chicago Metallic Corp.
 3. ACM-7 clip; USG.
 7. Wide-Face, Capped, Double-Web, Steel Suspension System: Main and cross runners roll formed from cold-rolled steel sheet, pre-painted, electrolytically zinc coated, or hot-dip galvanized according to ASTM A 653/A 653M, not less than G30 coating designation, with pre-finished 15/16-inch- wide metal caps on flanges.
 - a. Structural Classification: Heavy-duty system.
 - b. End Condition of Cross Runners: Butt-edge type.
 - c. Face Design: Flat, flush.
 - d. Cap Material: Steel or aluminum cold-rolled sheet.
 - e. Cap Finish: Painted in color as selected from manufacturer's full range.
- D. **Miscellaneous Materials:**
1. Acoustical Sealant: Resilient, non-staining, non-shrinking, non-hardening, non-skinning, non-drying, non-sag sealant intended for interior sealing of concealed construction joints.

PART 3 - EXECUTION

3.1 PREPARATION

- A. **Coordination:** Furnish layouts for inserts, clips, or other supports required to be installed by other trades for support of acoustical ceilings.
 1. Furnish concrete inserts, steel deck hanger clips and similar devices to other trades for installation well in advance of time needed for coordination of other work.
- B. **Layout:** Measure each ceiling area and establish layout of acoustical units to balance border widths at opposite edges of each ceiling. Avoid use of less-than-half width units at borders, and comply with reflected ceiling plans wherever possible.

3.2 INSTALLATION

- A. **General:** Install materials in accordance with manufacturer's printed instructions, and to comply with governing regulations, fire resistance rating requirements as indicated, and industry standards applicable to work.

- B. **Arrange acoustical units** and orient directionally-patterned units (if any) in manner shown by reflected ceiling plans.
 - 1. Install tile with pattern running in one direction.
- C. **Install suspension systems** to comply with ASTM C 636, with hangers supported only from building structural members. Locate hangers not less than 6 inches from each end and spaced 4 feet along each carrying channel or direct-hung runner, unless otherwise indicated, leveling to tolerance of 1/8 inch in 12 feet. Comply with detail on drawings for seismic bracing.
- D. **Secure wire hangers** by looping and wire-tying, either directly to structures or to inserts, eye-screws, or other devices which are secure and appropriate for substrate, and which will not deteriorate or fail with age or elevated temperatures.
 - 1. Install hangers plumb and free from contact with insulation or other objects within ceiling plenum which are not part of supporting structural or ceiling suspension system. Splay hangers only where required to miss obstructions and offset resulting horizontal force by bracing, countersplaying or other equally effective means.
- E. **Install edge moldings** of type indicated at perimeter of acoustical ceiling area and at locations where necessary to conceal edges of acoustical units.
 - 1. Screw-attach moldings to substrate at intervals not over 16 inches on center and not more than 3 inches from ends, leveling with ceiling suspension system to tolerance of 1/8 inch in 12 feet. Miter corners accurately and connect securely.
- F. **Install** acoustical panels in coordination with suspension system, with edges concealed by support of suspension members. Scribe and cut panels to fit accurately at borders and at penetrations.
 - 1. Paint cut and exposed edges of acoustical tile.
 - 2. Install hold-down clips in areas indicated, and in areas where required by governing regulations or for fire-resistance ratings; space as recommended by panel manufacturer, unless otherwise indicated or required.

3.3 ADJUST AND CLEAN

- A. **Clean exposed surfaces** of acoustical ceilings, including trim, edge moldings, and suspension members; comply with manufacturer's instructions for cleaning and touch-up of minor finish damage. Remove and replace work which cannot be successfully cleaned and repaired to permanently eliminate evidence of damage.

END OF SECTION

THIS PAGE LEFT BLANK INTENTIONALLY

SECTION 09 6513

RESILIENT BASE AND ACCESSORIES

PART 1 - GENERAL

1.1 RELATED DOCUMENTS

1. Drawings and general provisions of the Contract, including General and Supplementary Conditions and Division 01 Specification Sections, apply to this Section.

1.2 SUMMARY

1. **Section Includes:**
 1. Resilient base.
 2. Resilient molding accessories.
- B. **Related Sections:**
 1. **Key-Finish Legend** on Drawings for patterns and colors.
 2. Section 09 6513 "**Resilient Floor Coverings**" for base formed from vinyl floor covering.
 3. Section 09 3013 "**Ceramic Tile**" for tile cove base.

1.3 DELIVERY, STORAGE, AND HANDLING

1. **Store resilient products and installation materials in dry spaces** protected from the weather, with ambient temperatures maintained within range recommended by manufacturer, but not less than 50 degrees F or more than 90 degrees F.

1.4 FIELD CONDITIONS

1. **Maintain ambient temperatures** within range recommended by manufacturer, but not less than 70 degrees F or more than 95 degrees F, in spaces to receive resilient products during the following time periods:
 1. 48 hours before installation.
 2. During installation.
 3. 48 hours after installation.
2. **After installation and until Substantial Completion**, maintain ambient temperatures within range recommended by manufacturer, but not less than 55 degrees F or more than 95 degrees F.
3. **Install resilient products after** other finishing operations, including painting, have been completed.

PART 2 - PRODUCTS

2.1 STANDARD THERMOSET RUBBER BASE (B2)

1. **Acceptable Manufacturers:** Subject to compliance with requirements of Contract Documents, provide products by manufacturers listed below and as indicated in Key-Finish on Drawings. Substitutions will not be considered.
 1. Manufacturer: Tarkett.
 2. Product: Johnsonite Baseworks
2. **Product Standard:** ASTM F 1861, Type TS (rubber, thermoset), Group I (solid, homogeneous).
 1. Style and Location: Style B, Cove: Provide in areas with resilient flooring and where indicated on Drawings.
3. **Characteristics:**
 1. Thickness: 0.125 inch.
 2. Height: 4 inches, per schedule.
 3. Lengths: Coils in manufacturer's standard length.
 4. Outside Corners: Preformed, if available in selected colors; job-formed otherwise.
 5. Inside Corners: Job-formed.
4. **Colors:** As selected by Architect from full range of colors – refer to Key-Finish.

2.2 RUBBER MOLDING ACCESSORY

- A. **Acceptable Manufacturers:** Subject to compliance with requirements of Contract Documents, provide products by manufacturers listed below and as indicated in Key-Finish on Drawings. Substitutions will not be considered.
 1. Tarkett.
- B. **Description:** Vinyl edge products for glue-down applications for tile and carpet transitions.
 1. Profile and Dimensions: As indicated on Drawings.
 2. Locations: Provide molding accessories in areas indicated.
 3. Colors and Patterns: As indicated on Key-Finish Schedule or if not indicated, as selected by Architect from manufacturer's full range.

2.3 INSTALLATION MATERIALS

1. **Trowelable Leveling and Patching Compounds:** Latex-modified, Portland cement based or blended hydraulic-cement-based formulation provided or approved by resilient-product manufacturer for applications indicated.
2. **Adhesives:** Water-resistant type recommended by resilient-product manufacturer for resilient products and substrate conditions indicated.

PART 3 - EXECUTION

3.1 EXAMINATION

1. **Examine substrates**, with Installer present, for compliance with requirements for maximum moisture content and other conditions affecting performance of the Work.
 1. Verify that finishes of substrates comply with tolerances and other requirements specified in other Sections and that substrates are free of cracks, ridges, depressions, scale, and foreign deposits that might interfere with adhesion of resilient products.
2. **Proceed with installation only after** unsatisfactory conditions have been corrected.
 1. Installation of resilient products indicates acceptance of surfaces and conditions.

3.2 PREPARATION

1. **Prepare substrates** according to manufacturer's written instructions to ensure adhesion of resilient products.
2. **Fill cracks, holes, and depressions** in substrates with trowelable leveling and patching compound; remove bumps and ridges to produce a uniform and smooth substrate.
3. **Do not install resilient products** until they are the same temperature as the space where they are to be installed.
 1. At least 48 hours in advance of installation, move resilient products and installation materials into spaces where they will be installed.
4. **Immediately before installation**, sweep and vacuum clean substrates to be covered by resilient products.

3.3 RESILIENT BASE INSTALLATION

1. **Comply with manufacturer's written instructions** for installing resilient base.
2. **Apply resilient base** to walls, columns, pilasters, casework and cabinets in toe spaces, and other permanent fixtures in rooms and areas where base is required.
3. **Install resilient base in lengths as long as practical** without gaps at seams and with tops of adjacent pieces aligned.
4. **Tightly adhere resilient base** to substrate throughout length of each piece, with base in continuous contact with horizontal and vertical substrates.
5. **Do not stretch resilient base** during installation.
6. **On masonry surfaces** or other similar irregular substrates, fill voids along top edge of resilient base with manufacturer's recommended adhesive filler material.
7. **Preformed Corners:** Install preformed corners before installing straight pieces.

8. **Job-Formed Corners:**
 1. **Inside Corners:** Use straight pieces of maximum lengths possible and form with returns not less than 3 inches in length.
 - a. Miter or cope corners to minimize open joints.

3.4 RESILIENT ACCESSORY INSTALLATION

1. **Comply with manufacturer's written instructions** for installing resilient accessories.
2. **Resilient Molding Accessories:** Butt to adjacent materials and tightly adhere to substrates throughout length of each piece. Install reducer strips at edges of floor covering that would otherwise be exposed.

3.5 CLEANING AND PROTECTION

1. **Comply with manufacturer's written instructions** for cleaning and protecting resilient products.
2. **Perform the following operations** immediately after completing resilient-product installation:
 1. Remove adhesive and other blemishes from exposed surfaces.
3. **Protect resilient products** from mars, marks, indentations, and other damage from construction operations and placement of equipment and fixtures during remainder of construction period.
4. **Cover resilient products** subject to wear and foot traffic until Substantial Completion.

END OF SECTION

SECTION 09 6516

RESILIENT FLOOR COVERINGS

PART 1 - GENERAL

1.1 RELATED DOCUMENTS

- A. Drawings and general provisions of the Contract, including General and Supplementary Conditions and Division 1 Specification Sections, apply to this Section.

1.2 SUMMARY

- A. This **Section includes**:
 1. Vinyl sheet floor coverings (with covered base, as indicated).
 2. Vinyl composition tile (VCT).
 3. Sheet rubber flooring.
- B. **Related Sections**:
 1. Section 09 6513 "**Resilient Wall Base and Accessories**" for resilient wall base, stair treads, reducer strips, and other accessories installed with vinyl and rubber tile floor coverings.

1.3 SUBMITTALS

- A. **Product Data**: For each type of product indicated.
- B. **Shop Drawings**:
 1. Show locations of seams, edges, columns, doorways, enclosing partitions, built-in furniture, cabinets, and cutouts.
 2. Show details of special patterns.
- C. **Samples for Selection**: For each type floor covering indicated.
 1. Include similar samples of installation accessories involving color selection.
 2. Heat-Welding Bead: Include manufacturer's standard-size Samples, but not less than 9 inches long, of each color required.
 3. Components for flash cove base, including cove strip and cap.
- D. **Heat-Welded Seam Samples**: For each flooring product and welding bead color and pattern combination required; with seam running lengthwise and in center of 6-by-9-inch Sample applied to rigid backing and prepared by Installer for this Project.
- E. **Maintenance Data**: For floor coverings to include in maintenance manuals.

1.4 QUALITY ASSURANCE

- A. **Installer Qualifications**: A qualified installer who employs workers for this Project that are competent in techniques required by manufacturer for floor covering installation indicated.
- B. **Fire-Test-Response Characteristics**: Provide products identical to those tested for fire-exposure behavior per test method indicated by a testing and inspecting agency acceptable to authorities having jurisdiction.

1.5 DELIVERY, STORAGE, AND HANDLING

- A. **Store floor coverings and installation materials** in dry spaces protected from the weather, with ambient temperatures maintained within range recommended by manufacturer, but not less than 50 degrees F or more than 90 degrees F.

1.6 PROJECT CONDITIONS

- A. **Maintain temperatures within range recommended** by manufacturer, but not less than 70 degrees F or more than 95 degrees F, in spaces to receive floor tile during the following time periods:
 - 1. 72 hours before installation.
 - 2. During installation.
 - 3. 72 hours after installation.
- B. **After post-installation period**, maintain temperatures within range recommended by manufacturer, but not less than 55 degrees F or more than 95 degrees F.
- C. **Close spaces to traffic during** floor covering installation.
- D. **Close spaces to traffic for 72 hours after** floor covering installation.
- E. **Install floor coverings after** other finishing operations, including painting, have been completed.

1.7 EXTRA MATERIALS

- A. Furnish extra materials described below that match products installed and that are packaged with protective covering for storage and identified with labels describing contents.
 - 1. Sheet Goods: Furnish not less than 10 linear feet in full roll width for every 500 linear feet or fraction thereof, in roll form and in full roll width, of each different type, color, and pattern of sheet floor covering installed.

PART 2 - PRODUCTS

2.1 SHEET VINYL FLOOR COVERING

- A. **Type F1 - Acceptable Manufacturer:** Subject to compliance with requirements of Contract Documents, provide products by the following manufacturer. Substitutions will not be considered.
 - 1. Manufacturer: AHF Contract.
 - 2. Products: "Composed" Inlaid Heterogeneous Vinyl Sheet Flooring.
 - 3. Properties:
 - a. Color and Pattern: As indicated on Key-Finish Schedule on Drawings.
 - b. Sheet Floor Covering: Commercial flooring (non-phthalate construction) exceeding ASTM F-1913 requirements with a urethane wear layer. Patterns and colors shall extend through entire color-layer thickness.
 - 1) Roll Size: In manufacturer's standard length by not less than 72 inches wide.
 - 2) Seaming Method: Heat welded.
 - 3) Static Load Limit: 175 psi; residual indent \leq 0.005 inch.
 - 4) Overall Thickness: 2.0mm.
 - 5) Fire-Test-Response Characteristics: Class I, not less than 0.45 W/square centimeter per ASTM E 648.

- B. **Types F2 thru F5: Acceptable Manufacturer:** Subject to compliance with requirements of Contract Documents, provide products by the following manufacturer. Substitutions will not be considered.
1. Manufacturer: Mannington Commercial.
 2. Products: Biospec® MD.
 3. Properties:
 - a. Color and Pattern: As indicated on Key-Finish Schedule on Drawings.
 - b. Sheet Floor Covering: Commercial sheet (non-phthalate construction) exceeding ASTM F-1913 requirements with a urethane wear layer with aluminum oxide, cured by ultraviolet process. Patterns and colors shall extend through entire wear-layer thickness.
 - 1) Roll Size: In manufacturer's standard length by not less than 78 inches wide.
 - 2) Seaming Method: Heat welded.
 - 3) Static Load Limit: 2000 psi; residual indent \leq 0.005 inch.
 - 4) Overall Thickness: 0.080 inch.
 - 5) Fire-Test-Response Characteristics: Class I, not less than 0.45 W/square centimeter per ASTM E 648.

2.2 RUBBER SHEET FLOORING

Types F6 and F7: Acceptable Manufacturer: Subject to compliance with requirements of Contract Documents, provide products by the following manufacturer. Substitutions will not be considered.

1. Manufacturer: Nora Systems.
2. Products: Noraplan Sentica.
3. Properties:
 - a. Color and Pattern: As indicated on Key-Finish Schedule on Drawings.
 - b. Sheet Rubber Floor Covering: Commercial sheet meeting ASTM F1859 "Standard Specification for Rubber Sheet Floor Covering without Backing", Type I; homogeneous rubber compound with random scattered design. Patterns and colors shall extend through entire wear-layer thickness.
 - 1) Roll Size: In manufacturer's standard length by not less than 48 inches wide.
 - 2) Surface: Smooth.
 - 3) Hardness: Shore "A", 92.
 - 4) Seaming Method: Heat welded.
 - 5) Static Load Limit: 250 psi; residual indent \leq 0.005 inch.
 - 6) Overall Thickness: 2.0mm.
 - 7) Fire-Test-Response Characteristics: Class I, not less than 0.45 W/square centimeter per ASTM E 648.

2.3 VINYL COMPOSITION TILES

- A. **Type F8: Acceptable Manufacturer:** Subject to compliance with requirements of Contract Documents, provide products by the following manufacturer. Substitutions will not be considered.
1. Manufacturer: Armstrong Flooring.
 2. Products: Standard Excelon.
 3. Properties:
 - a. Colors and Patterns: As indicated on Key-Finish Schedule and Finish sheets on Drawings.

- b. Description: Tile composed of polyvinyl chloride resin, plasticizers, fillers, stabilizers and pigments with colors and texture dispersed uniformly throughout its entire thickness.
 - 1) Vinyl composition tile shall conform to the requirements of ASTM F 1066, "Standard Specification Vinyl Composition Floor Tile", Class 2, through-pattern
 - 2) Size: 12 in. x 12 in.
 - 3) Thickness: 1/8 inch/0.125 inch.

2.4 INSTALLATION MATERIALS

- A. **Trowelable Leveling and Patching Compounds:** Latex-modified, Portland cement based or blended hydraulic cement based formulation provided or approved by floor covering manufacturer for applications indicated.
- B. **Adhesives:** Water-resistant type recommended by floor covering manufacturer for products and substrate conditions indicated.
- C. **Heat-Welding Bead:** Solid-strand product of floor covering manufacturer.
 - 1. Color: Match floor covering, as selected by Architect.

PART 3 - EXECUTION

3.1 EXAMINATION

- A. **Examine substrates**, with Installer present, for compliance with requirements for installation tolerances, moisture content, and other conditions affecting performance.
 - 1. Verify that finishes of substrates comply with tolerances and other requirements specified in other Sections and that substrates are free of cracks, ridges, depressions, scale, and foreign deposits that might interfere with adhesion of floor coverings.
 - 2. Proceed with installation only after unsatisfactory conditions have been corrected.

3.2 PREPARATION

- A. **Prepare substrates** according to manufacturer's written recommendations to ensure adhesion of floor coverings.
- B. **Concrete Substrates:** Prepare according to ASTM F 710.
 - 1. Verify that substrates are dry and free of curing compounds, sealers, and hardeners.
 - 2. Alkalinity and Adhesion Testing: Perform tests recommended by manufacturer. Proceed with installation only after substrates pass testing.
 - 3. Moisture Testing:
 - a. Perform anhydrous calcium chloride test, ASTM F 1869. Proceed with installation only after substrates have maximum moisture-vapor-emission rate of 3 lb. of water/1000 sq. ft. in 24 hours.
 - b. Perform tests recommended by manufacturer. Proceed with installation only after substrates pass testing.
- C. **Remove substrate coatings and other substances** that are incompatible with floor covering adhesives and that contain soap, wax, oil, or silicone, using mechanical methods recommended by manufacturer. Do not use solvents.

- D. **Use trowelable leveling and patching compound** to fill cracks, holes, and depressions in substrates.
- E. **Move floor coverings and installation materials** into spaces where they will be installed at least 72 hours in advance of installation.
 - 1. Do not install floor coverings until they are same temperature as space where they are to be installed.
- F. **Sweep and vacuum clean substrates** to be covered by floor coverings immediately before installation. After cleaning, examine substrates for moisture, alkaline salts, carbonation, and dust. Proceed with installation only after unsatisfactory conditions have been corrected.

3.3 INSTALLATION, GENERAL

- A. **Scribe and cut floor coverings** to butt neatly and tightly to vertical surfaces, permanent fixtures, and built-in furniture including cabinets, pipes, outlets, edgings, thresholds, and nosings.
- B. **Extend floor coverings** into toe spaces, door reveals, closets, and similar openings.
- C. **Maintain reference markers**, holes, or openings that are in place or marked for future cutting by repeating on floor coverings as marked on subfloor. Use chalk or other nonpermanent marking device.
- D. **Install floor coverings** on covers for telephone and electrical ducts and similar items in finished floor areas. Maintain overall continuity of color and pattern with pieces of floor coverings installed on covers. Tightly adhere floor covering edges to substrates that abut covers and to cover perimeters.
- E. **Adhere floor coverings to substrates** using a full spread of adhesive applied to substrate to produce a completed installation without open cracks, voids, raising and puckering at joints, telegraphing of adhesive spreader marks, and other surface imperfections.
- F. **Heat-Welded Seams:** Comply with ASTM F 1516. Rout joints and use welding bead to permanently fuse sections into a seamless floor covering. Prepare, weld, and finish seams to produce surfaces flush with adjoining floor covering surfaces.
- G. **Cove Base:** Flash cove sheet flooring as indicated on Drawings and Key-Finish; use manufacturer's cove filler strips and cove caps as shown on Drawings and as directed by Architect.

3.4 SHEET FLOOR COVERING INSTALLATION

- A. **Unroll sheet floor coverings** and allow them to stabilize before cutting and fitting.
- B. **Lay out sheet floor coverings** as follows:
 - 1. Maintain uniformity of floor covering direction.
 - 2. Minimize number of seams; place seams in inconspicuous and low-traffic areas, at least 6 inches away from parallel joints in floor covering substrates.
 - 3. Match edges of floor coverings for color shading at seams.
 - 4. Avoid cross seams.

3.5 TILE INSTALLATION

- A. **Lay out tiles** from center marks established with principal walls, discounting minor offsets, so tiles at opposite edges of room are of equal width. Adjust as necessary to avoid using cut widths that equal less than one-half tile at perimeter.
 - 1. Lay tiles square with room axis.
- B. **Match tiles** for color and pattern by selecting tiles from cartons in the same sequence as manufactured and packaged, if so numbered. Discard broken, cracked, chipped, or deformed tiles.
- C. **Scribe, cut, and fit tiles** to butt neatly and tightly to vertical surfaces and permanent fixtures including built-in furniture, cabinets, pipes, outlets, edgings, door frames, thresholds, and nosings.

3.6 CLEANING AND PROTECTION

- A. Perform the following operations immediately after installing floor coverings:
 - 1. Remove adhesive and other surface blemishes from floor covering surfaces.
 - 2. Sweep and vacuum floor coverings thoroughly.
 - 3. Damp-mop floor coverings to remove marks and soil.
 - a. Do not wash floor coverings until after time period recommended by manufacturer.
- B. **Protect floor coverings** against mars, marks, indentations, and other damage from construction operations and placement of equipment and fixtures during remainder of construction period. Use protection methods indicated or recommended in writing by manufacturer.
 - 1. Apply protective floor polish when recommended by flooring manufacturer or as directed by Architect to surfaces that are free of soil, visible adhesive, and surface blemishes.
 - a. Seal as recommended by manufacturer but with not less than three coats of floor polish.
 - b. Use commercially available product acceptable to manufacturer.
 - c. Coordinate selection of floor polish with Owner's maintenance service.
 - 2. Cover vinyl floor coverings with undyed, untreated building paper until inspection for Substantial Completion.
 - 3. Do not move heavy and sharp objects directly over floor covering surfaces. Place plywood or hardboard panels over floor coverings and under objects while they are being moved. Slide or roll objects over panels without moving panels.

END OF SECTION

SECTION 09 9123

PAINTING

PART 1 - GENERAL

1.1 RELATED DOCUMENTS

- A. Drawings and general provisions of Contract, including General and Supplementary Conditions and Division-1 Specification sections, apply to work of this section.

1.2 SUMMARY

- A. **Section includes** painting work, **interior and exterior**. Work includes, but is not limited to painting the following:
1. Metal doors, metal door frames, and grilles.
 2. Interior gypsum walls and ceilings.
 3. Interior steel rails and miscellaneous metal.
 4. Concrete floors.
 5. Interior wood including but not limited to trim and moldings.
 6. Work includes field painting of exposed bare and covered pipes and ducts (including color coding), and of hangers, exposed steel and iron work, plug mold, electric panels, and primed metal surfaces of equipment installed under mechanical and electrical work, except as otherwise indicated.
- B. **Related Sections:**
1. **Shop Primers:** Unless otherwise specified, shop priming of ferrous metal items is included under various sections for structural steel, metal fabrications, hollow metal work and similar items.
 - a. Unless otherwise specified, shop priming of fabricated components such as architectural woodwork, wood casework and shop-fabricated or factory-built mechanical and electrical equipment or accessories is included under other sections of these specifications.
 - b. Comply with PDCA Standard P15 "Painting of Shop Primed Substrates"
- C. **"Paint"** as used herein means all coating systems materials, including primers, emulsions, enamels, stains, sealers and fillers, and other applied materials whether used as prime, intermediate or finish coats.
- D. **Gloss and Sheen Definitions** shall determine the equivalency of the desired finish luster when described in the construction documents by a traditional name instead of gloss units due to the wide variance of sheen descriptions available from manufacturer to manufacturer. Gloss shall be determined by ASTM D523 - 08 Standard Test Method for Specular Gloss.
1. Flat: Refers to a lusterless or matte finish with a gloss range below 5 units when measured with a 60 degree meter and no more than 10 units measured at an 85 degree meter.
 2. Low-Sheen: Refers to a velvet-like finish with a gloss range below 10 units when measured with a 60 degree meter and between 10-35 units measured at an 85 degree meter.
 4. Satin: Refers to low-to-medium range finish with a gloss range between 20-35 units when measured with a 60 degree meter and at least 35 units measured at an 85 degree meter.
 5. Semi-Gloss: Refers to a medium sheen finish with a gloss range between 35-70 units when measured with a 60 degree meter.

6. Gloss: Refers to a high sheen finish with a gloss range between 70-85 units when measured with a 60 degree meter.
 7. High-Gloss: Refers to a very high sheen finish with a gloss range more than 85 units when measured with a 60 degree meter.
- E. **Drywall Finishing Levels:** Except where otherwise specified, a Drywall Finishing Level 5 is required on gypsum board substrates scheduled to receive an eggshell or higher sheen. Drywall Finishing Level 4 is acceptable with the use of flat and low-sheen paints, except where critical lighting conditions are determined to be an issue by the Architect.
- F. **Surfaces to be Painted:** Except where natural finish of material is specifically noted as a surface not to be painted, paint all exposed surfaces whether or not colors are designated in "schedules". Where items or surfaces are not specifically mentioned, paint the same as similar adjacent materials or areas. If color or finish is not designated, Architect will select these from manufacturer's full range of colors and finishes. Multiple colors will be selected by the Architect for any type of paint system. If colors are not indicated on the Drawings or Finish Schedule, **provide for a minimum of 20 percent of the walls to be an accent color.**
1. **Surface preparation,** priming and coats of paint specified are in addition to shop-priming and surface treatment specified under other sections of work.
 2. Walls behind scheduled coverings shall receive prime coat.
 3. **If it can be seen, paint it.**
- G. **Following categories of work are not included** as part of field-applied finish work:
1. Pre-Finished Items: Unless otherwise indicated, do not include painting when factory-finishing or installer-finishing is specified for such items as (but not limited to) metal toilet enclosures, pre-finished partition systems, architectural woodwork and casework, elevator entrance doors and frames, elevator equipment, and finished mechanical and electrical equipment, including light fixtures, switchgear and distribution cabinets.
 2. Concealed Surfaces: Unless otherwise indicated, painting is not required on surfaces such as walls or ceilings in concealed areas and generally inaccessible areas, foundation spaces, furred areas, utility tunnels, pipe spaces and duct shafts.
 3. Finished Metal Surfaces: Unless otherwise indicated, metal surfaces of anodized aluminum, stainless steel, chromium plate, copper, bronze and similar finished materials will not require finish painting.
 4. Operating Parts: Unless otherwise indicated, moving parts of operating units, mechanical and electrical parts, such as valve and damper operators, linkages, sensing devices, motor and fan shafts will not require finish painting.
 5. Labels: Do not paint over any code-required labels, such as Underwriters' Laboratories and Factory Mutual, or any equipment identification, performance rating, name, or nomenclature plates.

1.3 SUBMITTALS

- A. **Product Data:** Submit manufacturer's technical information including Paint label analysis and application instructions for each material proposed for use.
- B. **Samples:** Prior to beginning work, review Finish Schedule for colors to be painted. Use representative colors when preparing samples for review. Submit samples for Architect's review of color and texture only. Provide a listing of material and application for each coat of each finish sample.
1. On 12 x 12 inch hardboard, provide two samples of each color and material, with texture to simulate actual conditions. Resubmit samples as requested by Architect until acceptable sheen, color, and texture is achieved.

2. On actual wall surfaces and other exterior and interior building components, duplicate painted finishes of prepared samples. Provide full-coat finish samples on at least 100 sq. ft. of surface, or as directed, until required sheen, color and texture is obtained; simulate finished lighting conditions for review of in-place work.
 - a. Demonstrate touch-up and repair technique on wall surface mock-ups.
 - b. Final acceptance of colors will be from samples applied on the job.

1.4 QUALITY ASSURANCE

- A. **Single Source Responsibility:** Provide primers and other undercoat paint produced by same manufacturer as finish coats. Use only thinners approved by paint manufacturer, and use only within recommended limits.
- B. **Coordination of Work:** Review other sections of these specifications in which prime paints are to be provided to ensure compatibility of total coatings system for various substrates. Upon request from other trades, furnish information or characteristics of finish materials provided for use, to ensure compatible prime coats are used.

1.5 DELIVERY AND STORAGE

- A. **Deliver materials** to job site in original, new and unopened packages and containers bearing manufacturer's name and label, and following information:
 1. Name or title of material.
 2. Federal Specification number, if applicable.
 3. Manufacturer's batch number and date of manufacture.
 4. Manufacturer's name.
 5. Contents by volume, for major pigment and vehicle constituents.
 6. Thinning instructions.
 7. Application instructions.
 8. Color name and number.
- B. **Store materials** not in actual use in tightly covered containers. Maintain containers used in storage of paint in a clean condition, free of foreign materials and residue.
 1. Protect from freezing where necessary. Keep storage area neat and orderly. Remove oily rags and waste daily. Take all precautions to ensure that workmen and work areas are adequately protected from fire hazards and health hazards resulting from handling, mixing and application of paints.

1.6 PROJECT CONDITIONS

- A. **Apply water-based paints** only when temperature of surfaces to be painted and surrounding air temperatures are between 50 degrees F and 90 degrees F, unless otherwise permitted by paint manufacturer's printed instructions.
- B. **Apply solvent-thinned paints** only when temperature of surfaces to be painted and surrounding air temperatures are between 45 degrees F and 95 degrees F, unless otherwise permitted by paint manufacturer's printed instructions.

- C. **Do not paint in snow, rain, fog or mist**, or when relative humidity exceeds 85 percent, or to damp or wet surfaces, unless otherwise permitted by paint manufacturer's printed instructions.
 - 1. Painting may be continued during inclement weather if areas and surfaces to be painted are enclosed and heated within temperature limits specified by paint manufacturer during application and drying periods.
- D. **Determine moisture content of surfaces** to be painted by performing appropriate tests using a commercially available moisture meter. Apply paint only when surfaces are within limits specified by the paint manufacturer's printed instructions.

1.7 MAINTENANCE MATERIALS

- A. **Furnish extra materials** that match products installed and that are packaged with protective covering for storage and identified with labels describing contents.
 - 1. Paint: 5 percent, but not less than 1 gallon of each material and color applied.

PART 2 - PRODUCTS

2.1 MANUFACTURERS

- A. **Acceptable Manufacturers:** Subject to compliance with requirements of Contract Documents, provide products by the manufacturer listed below. Substitutions will not be considered.
 - 1. Sherwin-Williams Company.
- B. **Painting Contractor** shall complete "Sherwin Williams Contractor Job Tracking Form" which follows this section and forward to Sherwin Williams as directed.

2.2 MATERIALS

- A. **Material Quality:** Provide best quality grade of various types of coatings as regularly manufactured by acceptable paint materials manufacturers. Materials not displaying manufacturer's identification as a standard, best-grade product will not be acceptable.
- B. **Proprietary names** used to designate color or materials are not intended to imply that products of named manufacturers are required to exclusion of equivalent products of other manufacturers.
- C. **Federal Specifications** establish minimum acceptable quality for paint materials. Provide written certification from paint manufacturer that materials provided meet or exceed these minimums.
- D. **Manufacturer's products** which comply with coating qualitative requirements of applicable Federal Specifications, yet differ in quantitative requirements, may be considered for use when acceptable to Architect. Furnish material data and manufacturer's certificate of performance to Architect for any proposed substitutions.
- E. **Color Pigments:** Pure, non-fading, applicable types to suit substrates and service indicated. Notify the Contractor in writing situations where the pigments of a chosen color are known to react with high alkalinity substrates (chemical burn), especially where the color is scheduled to be applied to a highly alkaline substrate. Notify Architect if color pigments will cause product to exceed allowable VOC limits.

- F. **Chemical Components of Interior Paints and Coatings:** Provide products that comply with the following limits for VOC content when calculated according to 40 CFR 59, Subpart D (EPA Method 24) and the following chemical restrictions:
1. Flat Paints and Coatings: VOC content of not more than 50 g/L.
 2. Non-Flat Paints and Coatings: VOC content of not more than 150 g/L.
 3. Anticorrosive Coatings: VOC content of not more than 250 g/L.
 4. Varnishes and Sanding Sealers: VOC content of not more than 350 g/L.
 5. Stains: VOC content of not more than 250 g/L.
 6. Aromatic Compounds: Paints and coatings shall not contain more than 1.0 percent by weight of total aromatic compounds (hydrocarbon compounds containing one or more benzene rings).
 7. Furnish products which have zero VOC content wherever possible.
- G. **Lead content in pigment,** if any, is limited to contain not more than 0.06 percent lead, as lead metal based on the total non-volatile (dry-film) of paint by weight.
1. This limitation is extended to interior surfaces and those exterior surfaces, such as stairs, decks, porches, railings, windows, and doors which are readily accessible to children under seven years of age.

PART 3 - EXECUTION

3.1 EXAMINATION

- A. **Applicator must examine areas and conditions** under which painting work is to be applied and notify Contractor in writing of conditions detrimental to proper and timely completion of work. Do not proceed with work until unsatisfactory conditions have been corrected in a manner acceptable to Applicator.
1. Comply with PDCA Standard P4 "Responsibility for Inspection and Acceptance of Surfaces prior to Painting and Decorating".
- B. **Starting of painting work will be construed** as Applicator's acceptance of surfaces and conditions within any particular area.
- C. **Do not paint over** dirt, rust, scale, grease, moisture, scuffed surfaces, or **conditions otherwise detrimental** to formation of a durable paint film.

3.2 PREPARATION

- A. **General:** Perform preparation and cleaning procedures in accordance with paint manufacturer's instructions and as herein specified, for each particular substrate condition.
- B. **Barrier Coats:** Provide barrier coats over incompatible primers or remove and re-prime as required. Notify Architect in writing of any anticipated problems in using the specified coating systems with substrates primed by others.
- C. **Accessories Removal:** Remove hardware, hardware accessories, machined surfaces, plates, lighting fixtures, and similar items in place and not to be finish-painted, or provide surface-applied protection prior to surface preparation and painting operations. Remove, if necessary, for complete painting of items and adjacent surfaces. Following completion of painting of each space or area, reinstall removed items.

- D. **Surface Preparation:** Clean surfaces to be painted before applying paint or surface treatments. Remove oil and grease prior to mechanical cleaning. Program cleaning and painting so that contaminants from cleaning process will not fall onto wet, newly-painted surfaces.
- E. **Cementitious Materials:** Prepare cementitious surfaces to be painted by removing efflorescence, chalk, dust, dirt, grease, oils, and by roughening as required to remove glaze.
1. Determine alkalinity and moisture content of surfaces to be painted by performing appropriate tests. If surfaces are found to be sufficiently alkaline to cause blistering and burning of finish paint, correct this condition before application of paint. Do not paint over surfaces where moisture content exceeds that permitted in manufacturer's printed directions.
 2. Clean concrete floor surfaces scheduled to be painted with a commercial solution or muriatic acid, or other etching cleaner. Flush floor with clean water to neutralize acid, and allow to dry before painting.
- F. **Ferrous Metals:** Clean ferrous surfaces, which are not galvanized or shop-coated, of oil, grease, dirt, loose mill scale and other foreign substances by solvent or mechanical cleaning.
1. Caulk fabrication joints in hollow metal door frames which paint application cannot bridge.
 2. Follow manufacturer's surface preparation recommendations for ferrous metal substrates, ranging from one of the following procedures:
 - a. SSPC-SP 1 - Solvent Cleaning (Nov-04)
 - b. SSPC-SP 2 - Hand Tool Cleaning (Nov-04)
 - c. SSPC-SP 3 - Power Tool Cleaning (Nov-04)
 - d. SSPC-SP 5/NACE No. 1 - White Metal Blast Cleaning (Jan-07)
 - e. SSPC-SP 6/NACE No. 3 - Commercial Blast Cleaning (Jan-07)
 - f. SSPC-SP 7/NACE No. 4 - Brush-Off Blast Cleaning (Jan-07)
 - g. SSPC-SP 8 - Pickling (Nov-04)
 - h. SSPC-SP 10/NACE No. 2 - Near-White Metal Blast Cleaning (Jan-07)
 - i. SSPC-SP 11 - Power Tool Cleaning to Bare Metal (July-12)
 - j. SSPC-SP 14/NACE No. 8 - Industrial Blast Cleaning (Jan-07)
 - k. SSPC-SP 15 - Commercial Grade Power-Tool Cleaning (July-12)
SSPC-SP 16 - Brush-Off Blast Cleaning of Coated and Uncoated Galvanized Steel, Stainless Steels, and Non-Ferrous Metals (Apr-10)
- G. **Touch-up:** Touch-up shop-applied prime coats wherever damaged or bare, where required by other sections of these specifications. Clean and touch-up with same type shop primer.
- H. **Galvanized Surfaces:** Clean free of oil and surface contaminants with non-petroleum based solvent. Comply with best practices specified in ASTM D6386 - 10 "Standard Practice for Preparation of Zinc (Hot-Dip Galvanized) Coated Iron and Steel Product and Hardware Surfaces for Painting."
- I. **Wood:** Clean wood surfaces to be painted of dirt, oil, or other foreign substances with scrapers, mineral spirits, and sandpaper, as required. Sandpaper smooth those finished surfaces exposed to view, and dust off. Scrape and clean small, dry, seasoned knots and apply a thin coat of white shellac or other recommended knot sealer, before application of priming coat. After priming, fill holes and imperfections in finish surfaces with putty or plastic wood-filler. Sandpaper smooth when dried.
1. Prime, stain, or seal wood required to be job-painted immediately upon delivery to job. Prime edges, ends, faces, undersides, and backsides of such wood, including cabinets, counters, cases, paneling.

2. When transparent finish is required, use spar varnish for backpriming.
3. Exterior Wood Substrates:
 - a. Scrape and clean knots, and apply coat of knot sealer before applying primer.
 - b. Prime edges, ends, faces, undersides, and backsides of wood.
 - 1) For solid hide stained wood, stain edges and ends after priming.
 - 2) For varnish-coated stained wood, stain edges and ends and prime with varnish. Prime undersides and backsides with varnish.
 - c. Countersink steel nails, if used, and fill with putty or plastic wood filler tinted to final color. Sand smooth when dried.
4. Interior Wood Substrates:
 - a. Scrape and clean knots, and apply coat of knot sealer before applying primer.
 - b. Apply wood filler paste to open-grain woods, as defined in "MPI Architectural Painting Specification Manual," to produce smooth, glasslike finish.
 - c. Sand surfaces exposed to view and dust off.
 - d. After priming, fill holes and imperfections in the finish surfaces with putty or plastic wood filler. Sand smooth when dry.

J. Materials Preparation:

1. Mix and prepare painting materials in accordance with manufacturer's directions.
2. Maintain containers used in mixing and application of paint in a clean condition, free of foreign materials and residue.
3. Stir materials before application to produce a mixture of uniform density, and stir as required during application. Do not stir surface film into material. Remove film and, if necessary, strain material before using.

3.3 APPLICATION

- A. General:** Apply paint in accordance with manufacturer's directions. Use applicators and techniques best suited for substrate and type of material being applied.
1. Paint colors, surface treatments, and finishes, are indicated in "schedules" of the Contract Documents.
 2. Provide finish coats which are compatible with prime paints used.
 3. Apply additional coats when undercoats, stains or other conditions show through final coat of paint, until paint film is of uniform finish, color and appearance. Give special attention to insure that surfaces, including edges, corners, crevices, welds, and exposed fasteners receive a dry film thickness equivalent to that of flat surfaces.
 4. Paint surfaces behind movable equipment and furniture same as similar exposed surfaces. Paint surfaces behind permanently-fixed equipment or furniture with prime coat only before final installation of equipment.
 5. Paint interior surfaces of ducts, where visible through registers or grilles, with a flat, non-specular black paint.
 6. Paint back sides of access panels, and removable or hinged covers to match exposed surfaces.
 7. Finish doors on tops, bottoms and side edges same as faces, unless otherwise indicated.
 8. Sand lightly between each succeeding enamel or varnish coat.
 9. Omit first coat (exterior faces) of surfaces which have been shop-primed and touch-up painted, unless otherwise indicated.

- B. **Scheduling Painting:** Apply first-coat material to surfaces that have been cleaned, pretreated or otherwise prepared for painting as soon as practicable after preparation and before subsequent surface deterioration.
1. Re-coat Time: Allow sufficient time between successive coatings to permit proper drying. Do not recoat until paint has dried to where it feels firm, does not deform or feel sticky under moderate thumb pressure, and application of another coat of paint does not cause lifting or loss of adhesion of the undercoat.
 2. Minimum Coating Thickness: Apply materials at not less than manufacturer's recommended spreading rate, to establish a total dry film thickness as indicated or, if not indicated, as recommended by coating manufacturer.
- C. **Mechanical and Electrical Work:** Painting of mechanical and electrical work is limited to those items exposed to mechanical equipment rooms and in occupied spaces.
1. Mechanical items to be painted include, but are not limited to, the following:
 - a. Piping, pipe hangers, and supports.
 - b. Roof mounted mechanical units.
 - c. Ductwork, where exposed in occupied spaces.
 - d. Motor, mechanical equipment, and supports.
 - e. Accessory items.
 2. Electrical items to be painted include, but are not limited to, the following:
 - a. Conduit and fittings.
- D. **Prime Coats:** Apply prime coat of material which is required to be painted or finished, and which has not been prime coated by others.
1. Recoat primed and sealed surfaces where there is evidence of suction spots or unsealed areas in first coat, to assure a finish coat with no burn-through or other defects due to insufficient sealing.
- E. **Pigmented (Opaque) Finishes:** Completely cover to provide an opaque, smooth surface of uniform finish, color, appearance and coverage. Cloudiness, spotting, holidays, laps, brush marks, runs, sags, ropiness or other surface imperfections will not be acceptable.
- F. **Completed Work:** Match approved samples for color, texture and coverage. Remove, refinish or repaint work not in compliance with specified requirements.

3.4 FIELD QUALITY CONTROL

- A. **Owner will engage services of an independent testing laboratory** to sample paint being used. Samples of materials delivered to project site will be taken, identified and sealed, and certified in presence of Contractor.
1. Testing laboratory will perform appropriate tests for any or all of following characteristics: Abrasion resistance, apparent reflectivity, flexibility, washability, absorption, accelerated weathering, dry opacity, accelerated yellowness, recoating, skinning, color retention, alkali resistance and quantitative materials analysis.
- B. **If test results show** that material being used does not comply with specified requirements, Contractor may be directed to stop painting work, and remove non-complying paint; pay for testing; repaint surfaces coated with rejected paint; remove rejected paint from previously painted surfaces if, upon repainting with specified paint, the two coatings are non-compatible.

3.5 CLEAN-UP AND PROTECTION

- A. **Clean-Up:** During progress of work, remove from site discarded paint materials, rubbish, cans and rags at end of each work day.
1. Upon completion of painting work, clean window glass and other paint spattered surfaces. Remove spattered paint by proper methods of washing and scraping, using care not to scratch or otherwise damage finished surfaces.
- B. **Protection:** Protect work of other trades, whether to be painted or not, against damage by painting and finishing work. Correct any damage by cleaning, repairing or replacing, and repainting, as acceptable to Architect.
1. Provide "Wet Paint" signs as required to protect newly-painted finishes. Remove temporary protective wrappings provided by others for protection of their work, after completion of painting operations.
 2. At completion of work of other trades, touch-up and restore all damaged or defaced painted surfaces.

3.6 INTERIOR PAINT SCHEDULE

- A. **General:** Provide the following paint systems for the various substrates as indicated below or equivalent system from approved manufacturers listed above.

B. **Metal - Interior Galvanized**

Preparation: Remove all oil and grease from surface per SSPC-SP1. Protect adjacent surfaces from damage. Prepare surface in accordance with commercial blast cleaning SSPC-SP6 with median surface profile of 1.5 to 2.0 mils.

Sherwin-Williams - Latex (100% Acrylic) Systems

1st Coat: S-W Pro Industrial Pro-Cryl Universal Primer B66-310 Series

Finish: Low sheen.

Thickness (Mils per coat): 5 - 10 wet; 2 - 4 dry.

2nd Coat: S-W Pro Industrial Zero VOC Acrylic Semi-Gloss, B66-650 Series

3rd Coat: S-W Pro Industrial Zero VOC Acrylic Semi-Gloss, B66-650 Series

Finish: Semi-Gloss

Thickness (Mils per coat): 6 - 12 wet; 2.5 - 4 dry.

C. Metal - Interior Structural Steel - Columns, Joists, Trusses, Beams - Misc. & Ornamental Iron, Doors, Door Frames, Non-Galvanized Metal

Preparation: Remove all oil and grease from surface per SSPC-SP1. Protect adjacent surfaces from damage. Prepare surface in accordance with commercial blast cleaning SSPC-SP6 with median surface profile of 1.5 to 2.0 mils.

Sherwin-Williams - Latex (100% Acrylic) Systems

1st Coat: S-W Pro Industrial Pro-Cryl Universal Primer B66-310 Series

Finish: Low sheen.

Thickness (Mils per coat): 5 - 10 wet; 2 - 4 dry.

2nd Coat: S-W Pro Industrial Zero VOC Acrylic Gloss, B66-600 Series

3rd Coat: S-W Pro Industrial Zero VOC Acrylic Gloss, B66-600 Series

Finish: Gloss

Thickness (Mils per coat): 6 - 12 wet; 2.5 - 4 dry.

D. Drywall - Walls, Ceilings, Gypsum Board, Etc.

Preparation: Fill cracks and holes with patching paste/spackle and sand smooth. Joint compounds must be cured and sanded smooth. Remove all sanding dust. Finish exposed gypsum surfaces to Level 5 finish.

Sherwin-Williams - Vinyl Acrylic Systems

1st Coat: S-W ProMar 200 Zero VOC Interior Latex Primer, B28W02600 Series – use “P”-shade primer.

Finish: Flat

Sheen (at 85 degrees): 0 - 5 units.

Thickness: (Mils per coat) 4 wet; 1.5 dry.

2nd Coat: S-W ProMar 200 Zero VOC Latex Semi-Gloss, B31-2600 Series

3rd Coat: S-W ProMar 200 Zero VOC Latex Semi-Gloss, B31-2600 Series

Finish: Semi-Gloss

Sheen (at 60 degrees): 25 - 35 units

Thickness (Mils per coat): 4 wet; 1.6 dry.

E. Drywall - Interior Epoxy System - Walls, Ceilings, Gypsum Board, Etc.

Preparation: Fill cracks and holes with patching paste/spackle and sand smooth. Joint compounds must be cured and sanded smooth. Remove all sanding dust. Finish exposed gypsum surfaces to Level 5 finish.

Sherwin-Williams - Epoxy System (Water Base) with Vinyl Acrylic Primer

1st Coat: S-W ProMar 200 Zero VOC Interior Latex Primer, B28W02600 Series – use “P”-shade primer.

Finish: Flat

Sheen (at 85 degrees): 0 - 5 units

Thickness (Mils per coat): 4 wet; 1.5 dry.

2nd Coat: S-W Pro Industrial Zero VOC Water-Based Epoxy Gloss, B73-300 series

3rd Coat: S-W Pro Industrial Zero VOC Water-Based Epoxy Gloss, B73-300 series

Finish: Gloss (Verify with Architect and Owner)

Sheen (at 60 degrees): 90+ units.

Thickness (Mils per coat): 5 - 10 wet; 2 - 4 dry.

F. Drywall - Interior Graphics, Deep Tone Accents, Special Features, Etc.

Preparation: Fill cracks and holes with patching paste/spackle and sand smooth. Joint compounds must be cured and sanded smooth. Remove all sanding dust. Finish exposed gypsum surfaces to Level 5 finish.

Sherwin-Williams - Vinyl Acrylic

1st Coat: S-W ProMar 200 Zero VOC Interior Latex Primer, B28W2600 Series – use “P”-shade primer.

Finish: Flat

Sheen (at 85 deg): 0 - 5 units

Thickness (Mils per coat): 4 wet; 1.5 dry.

2nd Coat: S-W ProMar 200 Zero VOC Semi-Gloss B31-2600 series

3rd Coat: S-W ProMar 200 Zero VOC Semi-Gloss B31-2600 series

Sheen (at 60 degrees): 25 - 35 units.

Thickness (Mils per coat): 4 wet; 1.6 dry.

G. Drywall - Interior behind Wall Panels, Casework etc.

Preparation: Fill cracks and holes with patching paste/spackle and sand smooth. Joint compounds must be cured and sanded smooth. Remove all sanding dust. Finish exposed gypsum surfaces to Level 5 finish.

Sherwin-Williams - Vinyl Acrylic

1st Coat: S-W ProMar 200 Zero VOC Interior Latex Wall Primer, B28W2600 Series.

Finish: Flat

Sheen (at 85 degrees): 0 - 5 units

Thickness (Mils per coat): 4 wet; 1.5 dry.

H. Concrete Slabs - Epoxy Coating

Preparation: Cure concrete floors for a minimum of 28 days. Test floor for vapor drive in accordance with ASTM D4263. Use a commercial degreaser to clean floors of oil, grease, and other bond-inhibiting materials. Remove curing and parting compounds and other surface hardeners and floor coatings in accordance with the manufacturer's instructions. Mechanically profile floor to CSP 3 (approximating medium-grit sandpaper) as described by the International Concrete Repair Institute - verify profile with flooring manufacturer and adjust as appropriate. Do not use acid etching for surface preparation. Do not use any method that will fracture the concrete. Patch/repair any cracks in accordance with manufacturer's recommendations.

Epoxy-Coat 100 percent Solids Cycloaliphatic Epoxy

1st coat: 'Epoxy-Coat® - apply at a rate recommended by manufacturer to a minimum dry thickness of 9.7 mils.

Color: Applied color flakes as selected by the Architect from the manufacturer's standard colors.

Non-Skid Surface: At mechanical rooms, and where indicated on Drawings, apply aluminum oxide at manufacturer's recommended rate.

Where indicated on Drawings, seal wall/floor joint and extend epoxy polymer up wall 4 inches to termination bar.

I. Woodwork - Stained & Varnished - Clear Finish

Preparation: Wood must be dry and cleaned of dirt, grease, wax, polish, marks, and old finishes. Sand wood to a smooth surface using 100-120 grit paper. Remove sanding dust with a vacuum or tack cloth. New wood must be stored inside for a minimum of 24 hours prior to staining.

Open Grained Wood

1st Coat: S-W WoodClassics 250 g/L Stain, A49W800 Series
2nd Coat: S-W SHERWOOD Natural Filler, D70T1
3rd Coat: S-W Minwax WB Polyurethane, <275 g/L VOC
4th Coat: S-W Minwax WB Polyurethane, <275 g/L VOC
Finish: Satin or gloss, as selected by Architect.

Closed Grain Wood

1st Coat: S-W WoodClassics 250g/L Stain, A49W800 Series
2nd Coat: S-W Minwax WB Polyurethane, <275 g/L VOC
3rd Coat: S-W Minwax WB Polyurethane, <275 g/L VOC
Finish: Satin or gloss, as selected by Architect.

J. Woodwork - Natural - Clear Finish

Preparation: Wood must be dry and cleaned of dirt, grease, wax, polish, marks, and old finishes. Sand wood to a smooth surface using 100-120 grit paper. Remove sanding dust with a vacuum or tack cloth. New wood must be stored inside for a minimum of 24 hours prior to staining.

Open Grained Wood

1st Coat: S-W SHERWOOD Natural Filler, D70T1
2nd Coat: S-W Minwax WB Polyurethane, <275 g/L VOC
3rd Coat: S-W Minwax WB Polyurethane, <275 g/L VOC
Finish: Satin or gloss, as selected by Architect.

Closed Grain Wood

1st Coat: S-W Minwax WB Polyurethane, <275 g/L VOC
2nd Coat: S-W Minwax WB Polyurethane, <275 g/L VOC
Finish: Satin or gloss, as selected by Architect.

K. Woodwork - Painted

Preparation: Wood must be dry and cleaned of dirt, grease, wax, polish, marks, and old finishes. Sand wood to a smooth surface using 100-120 grit paper. Remove sanding dust with a vacuum or tack cloth. New wood must be stored inside for a minimum of 24 hours prior to staining.

Sherwin-Williams Latex Systems - Semi-Gloss

1st Coat: S-W ProMar 200 Zero VOC Interior Latex Primer, B28W2600 Series.
2nd Coat: S-W ProMar 200 Zero VOC Semi-Gloss B31-2600 series
3rd Coat: S-W ProMar 200 Zero VOC Semi-Gloss B31-2600 series
Thickness (Mils per coat): 4 wet; 1.6 dry

END OF SECTION

THIS PAGE LEFT BLANK INTENTIONALLY

Sherwin Williams Contractor Job Tracking Form

To be included in Contractor Bid Package

Instructions for Contractor:

- Please complete this form with as much information as available
- If you have an assigned Sherwin Williams Sales Representative or a Home store that services, your account please contact them directly with this form
- If you do not have a Sherwin Williams assigned account manager, please email this form to Michael.J.Koncilja@Sherwin.com
- This form must be forwarded to Sherwin Williams prior to the start of any Capital Expenditure Project
- A job account must be assigned for every project

Instructions for Sherwin Williams Employees:

- Upon receiving this form please open a job account for the paint contractor
- The job account must read as follows: Intermountain Healthcare/Name of City/ Project Name
- A job account is strictly required for all IHC related projects
- Upon opening an IHC job account, an email containing the 9 digit job account number is to be sent to Michael.J.Koncilja@Sherwin.com for tracking purposes
- A request for this project to be linked to Parent #5540 will be communicated
- All Purchases associated with said project are to be made on this job account only

Project Tracking Form

Name of Contractor: _____

Sherwin Williams Account number (Existing): _____

IHC Job Account number (To be assigned): _____

Name and Address of IHC related

Project: _____

Name/Store of Sherwin Williams

Contact: _____

Estimated Materials Needed: _____

Estimated Project Start Date: _____

Additional Comments/Needs of Contractor: (I.E renderings needed,
drawdowns required, Special environmental
restrictions.) _____

DIVISION 10 – SPECIALTIES

Section 10 2123	Cubicle Tracks and Curtains
Section 10 2613	Corner Guards
Section 10 2623.13	Impact Resistant Wall Protection
Section 10 2800	Toilet and Bath Accessories
Section 10 4400	Fire-Protection Specialties

THIS PAGE LEFT BLANK INTENTIONALLY

SECTION 10 2123

CUBICLE TRACKS AND CURTAINS

PART 1 - GENERAL

1.1 RELATED DOCUMENTS

- A. Drawings and general provisions of the Contract, including General and Supplementary Conditions and Division 1 Specification Sections, apply to this Section.

1.2 SUMMARY

- A. **Section Includes:**
 - 1. Suspended overhead metal curtain track and guides.
 - 2. Curtains.
- B. **Related Requirements**
 - 1. Section 05 5000 "**Metal Fabrication**" for track supports above ceiling.
 - 2. Section 06 1053 "**Miscellaneous Carpentry**" for blocking and supports for track.
 - 3. Section 09 5100 "**Acoustical Ceilings**" for suspended ceiling system to support track.

1.3 SUBMITTALS

- A. **Product Data:** Provide data for curtain fabric characteristics.
- B. **Shop Drawings:** Indicate a reflected ceiling plan view of curtain track, hangers and suspension points, attachment details, schedule of curtain sizes.
- C. **Samples for Selection (Fabric):** Submit two 6 x 6 inch (or larger as required to adequately demonstrate pattern and range of color) fabric samples illustrating each fabric color and pattern for entire product line.
- D. **Samples for Verification (Fabric):** Submit 12 x 12 inch sample patch of curtain cloth with representative hem stitch detail, heading with reinforcement, and carrier attachment to curtain header.
- E. **Samples for Verification (Track):** Submit 12 inch sample length of curtain track including typical splice and wall and ceiling hanger and escutcheon.
- F. **Manufacturer's Installation Instructions:** Indicate special procedures, perimeter conditions requiring special attention.

1.4 DELIVERY, STORAGE, AND HANDLING

- A. **Accept curtain materials** on site and inspect for damage.
- B. **Store curtain materials** on site and deliver to Owner for installation when requested.

PART 2 - PRODUCTS

2.1 ACCEPTABLE MANUFACTURERS

- A. **Cubicle Track and Curtains:** Subject to compliance with requirements of Contract Documents, provide products by the manufacturer listed below. No substitutions will be considered.
1. Manufacturer: Construction Specialties, Inc.
 2. System: C/S Cubicle Curtains; "On the Right Track" curtain and track system.

2.2 TRACKS AND TRACK COMPONENTS

- A. **Track:** Extruded aluminum sections; one piece per cubicle track run; I-beam profile.
1. Structural Performance: Capable of supporting vertical test load of 50 lbs without visible deflection of track or damage to supports, safely supporting moving loads, and sufficiently rigid to resist visible deflection and without permanent set.
 2. Track End Stop: To fit track section.
 3. Track Bends: Minimum 12 inch radius; fabricated without deformation of track section or impeding movement of carriers.
 4. Suspension Rods: Tubular Aluminum sections, sized to support design loads and designed to receive attachment from track and ceiling support.
 5. Escutcheons to Suspension Rods: Aluminum.
 6. Finish on Exposed Surfaces: Clear anodized finish.
- B. **Wand:** Aluminum hollow section, attached to lead carrier, for pull-to-close action.

2.2 CURTAINS

- A. **All Curtain Materials:**
1. Flame spread index of 25, maximum; smoke developed index of 450, maximum; when tested in accordance with ASTM E84.
- B. **Curtain:** Close weave 100 percent polyester; anti-bacterial, self-deodorizing, sanitized, and preshrunk.
1. Pattern: C/S "New Shadow Cube".
 2. Color: "Cookie" or as selected by Architect.
 3. Integral rings designed to mount directly to track.
- C. **Open Mesh Cloth:** Open weave to permit air circulation; flameproof material, color as selected by Architect.
- D. **Curtain Fabrication:**
1. Manufacture curtains of one piece, sized 10 percent wider than track length. Terminate curtain 15 inches from floor. Verify orientation of fabric pattern with Architect prior to fabrication.
 2. Include open mesh cloth at top 18 inches of curtain for room air circulation.
 3. Curtain Heading: Hookless split rings integrated in curtain, double fold bottom hem 2 inches wide with lead weights included. Lock stitch seams in two rows. Turn seam edges and lock stitch.

PART 3 - EXECUTION

3.1 EXAMINATION

- A. **Verify surfaces and supports** above ceiling are ready to receive work of this Section.
- B. **Verify field measurements** are as indicated on shop drawings.

3.2 INSTALLATION

- A. **Install curtain track** to be secure, rigid, and true to ceiling line.
- B. **Install end cap** and stop device.
- C. **Install curtains** on carriers ensuring smooth operation.

END OF SECTION

THIS PAGE LEFT BLANK INTENTIONALLY

SECTION 10 2613

CORNER GUARDS

PART 1 - GENERAL

1.1 RELATED DOCUMENTS

- A. Drawings and general provisions of the Contract, including General and Supplementary Conditions and Division 1 Specification Sections, apply to this Section.

1.2 SUMMARY

- A. **This Section includes** the following types of protection guards:
 - 1. Corner guards

1.3 SUBMITTALS

- A. **Product Data:** Product data for each type of wall guard specified, including details of construction relative to materials, dimensions of individual components, profiles, and finishes.
- B. **Drawings:** Shop drawings detailing fabrication and installation of wall guards. Include plans, elevations, and large-scale details showing layout and types required. Show anchorages and accessory items.
- C. **Samples:** For verification of colors, patterns, and surface texture.
 - 1. 12 inch long samples of each type of wall guard required. Include examples of joinery, corners, and field splices.

1.4 QUALITY ASSURANCE

- A. **Manufacturer Qualifications:** A firm experienced in manufacturing wall and corner guards similar to that indicated for this Project and that has a record of successful in-service performance.
- B. **Design Criteria:** Drawings indicate sizes, profiles, and dimensional requirements of the various items of wall and corner guards and are based on the specific types and models indicated. Similar equipment by other manufacturers may be considered, provided deviations in dimensions and profiles are minor and do not change the design concept as judged by the Architect. The burden of proof of equality is on the proposer.

PART 2 - PRODUCTS

2.1 PVC WALL PROTECTION

- A. **Basis of Design:** Contract Documents are based on products specified below to establish a standard of quality. Other available manufacturers offering products with equivalent characteristics may be considered, provided deviations are minor and design concept as expressed in the Contract Documents is not changed, as judged by the Architect.
 - 1. Manufacturer: Inpro Corporation.
 - 2. Products: As indicated on Key-Finish Legend.

- B. **Available Manufacturers:** Subject to compliance with requirements, manufacturers offering products that may be incorporated in the Work include, but are not limited to, the following:
1. Inpro Corporation.
 2. Construction Specialties.
 3. Koroseal Interior Products, LLC.
 4. Pawling Corporation; Standard Products Division.
- C. **Rigid Plastic Material:** Extruded, textured, chemical- and stain-resistant, high-impact, engineered non-PVC PETG with biopolymer, thickness as indicated. Comply with specified requirements of ASTM D 256 for impact resistance and ASTM E 84 for flame spread and smoke developed characteristics.
1. Colors and Textures of Plastic Material: Provide extruded plastic material that matches selections made by the Architect from the manufacturer's full range of standard colors and textures.
 2. Thickness: 0.080 inch
 3. Furnish complete with top caps, inside corners, and outside corners.
- D. **Corner Guards:** 2 x 2 inch wings with snap-on covers of 0.080-inch thickness form PETG with biopolymer blend on continuous aluminum retainer of 0.070-inch thickness fabricated from 6063-T5 aluminum with mill finish. Include matching injection-molded top caps.

2.3 COMPONENTS

- A. **End Caps, Inside Corners and Outside Corners:** Injection molded thermoplastics.
- B. **Molded Reveals:** Smooth finish; black.
- C. **Fasteners:** Provide mounting system accessories appropriate for substrates indicated on Drawings or as directed by Architect.

2.4 FINISHES

- A. **Molded Components:** End Caps, inside corners and outside corners shall be of a color matching the wall guards. Surface shall have a pebble texture.
- B. **Adhesive:** Heavy duty adhesive, as approved by manufacturer; nonflammable, high strength, water-dispersed contact adhesive, with very little odor.

PART 3 - EXECUTION

3.1 PREPARATION

- A. **General:** Coordinate installation of corner guards indicated to be attached to concrete or masonry, and furnish anchoring devices with templates, diagrams, and instructions for their installation.
1. Coordinate delivery of anchoring devices to Project site to avoid delaying progress.

3.2 INSTALLATION

- A. **General:** Comply with manufacturer's detailed instructions for installing corner guards.
- B. **Corner Guards:** Install wall surface protection units plumb, level, and true to line

without distortions.

1. Do not use materials with chips, cracks, voids, stains, or other defects that might be visible in the finished work.
2. Install guards as indicated on Drawings.

3.3 ADJUST AND CLEAN

- A. **After installation**, restore marred, abraded surfaces to the original condition. Replace any component that cannot be repaired to the satisfaction of the Architect.

END OF SECTION

THIS PAGE LEFT BLANK INTENTIONALLY

SECTION 10 2623.13

IMPACT RESISTANT WALL PROTECTION

PART 1 - GENERAL

1.1 RELATED DOCUMENTS

- A. Drawings and general provisions of the Contract, including General and Supplementary Conditions and Division 1 Specification Sections, apply to this Section.

1.2 SUMMARY

- A. **This Section includes** the following types of protection guards:
 - 1. PETG wall protection.

1.3 SUBMITTALS

- A. **Product Data:** Product data for each type of wall and corner guard specified, including details of construction relative to materials, dimensions of individual components, profiles, and finishes.
- B. **Drawings:** Shop drawings detailing fabrication and installation of wall guards. Include plans, elevations, and large-scale details showing layout and types required. Show anchorages and accessory items.
- C. **Samples:** For verification of colors, patterns, and surface texture.
 - 1. 7 x 9 inch samples of each rigid sheet or panel type wall surface protection material required.

1.4 QUALITY ASSURANCE

- A. **Manufacturer Qualifications:** A firm experienced in manufacturing wall and corner guards similar to that indicated for this Project and that has a record of successful in-service performance.
- B. **Design Criteria:** Drawings indicate sizes, profiles, and dimensional requirements of the various items of wall and corner guards and are based on the specific types and models indicated. Similar equipment by other manufacturers may be considered, provided deviations in dimensions and profiles are minor and do not change the design concept as judged by the Architect. The burden of proof of equality is on the proposer.

PART 2 - PRODUCTS

2.1 WALL PROTECTION

- A. **Acceptable Manufacturers:** Subject to compliance with requirements of Contract Documents, provide products from manufacturer listed below. Substitutions will not be considered.
 - 1. Inpro Corporation.

- B. **Rigid Plastic Material:** Extruded, textured, chemical- and stain-resistant, high-impact, PETG (PVC-free), thickness as indicated. Comply with specified requirements of ASTM D 256 for impact resistance and ASTM E 84 for flame spread and smoke developed characteristics.
 - 1. Colors and Textures of Plastic Material: Provide extruded plastic material that matches selections made by the Architect from the manufacturer's full range of standard colors and textures.
 - 2. Thickness: 0.040 inch
 - 3. Texture: Suede

- C. **Top Caps, Vertical Divider Bars and Inside Corners:** Extruded from chemical and stain resistant non-PVC thermoplastic; color to match wall protection sheets.

PART 3 - EXECUTION

3.1 PREPARATION

- A. **General:** Prior to installation, clean substrate to remove dust, debris and loose particles. Paint substrate with a paint or primer that does not contain polyvinyl acetate (PVA).

3.2 INSTALLATION

- A. **General:** Comply with manufacturer's detailed instructions for installing wall and corner guards.

- B. **Wall Guards:** Install wall surface protection units plumb, level, and true to line without distortions.
 - 1. Do not use materials with chips, cracks, voids, stains, or other defects that might be visible in the finished work.
 - 2. Install guards above wall base; guards shall extend from top of base to height shown on Drawings.

3.3 ADJUST AND CLEAN

- A. **After installation,** restore marred, abraded surfaces to the original condition.

END OF SECTION

SECTION 10 2800

TOILET AND BATH ACCESSORIES

PART 1 - GENERAL

1.1 RELATED DOCUMENTS

- A. Drawings and general provisions of the Contract, including General and Supplementary Conditions and Division 1 Specification Sections, apply to this Section.

1.2 SUMMARY

- A. This **Section includes** but is not limited to the following:
 1. Toilet tissue dispenser (furnished by Owner/installed by Contractor).
 2. Soap dispenser (furnished by Owner/installed by Contractor).
 3. Paper towel dispensers (furnished by Owner/installed by Contractor).
 4. Toilet seat cover dispensers (furnished by Owner/installed by Contractor).
 5. Grab bars.
 6. Sanitary napkin disposal unit.
 7. Shelf unit.
 8. Mirror unit.
 9. Underlavatory guards.
 10. Specimen pass-thru.
- B. **Related Sections** include the following:
 1. Section 06 1053 "**Miscellaneous Rough Carpentry**" for wood blocking in walls.
 2. Section 09 2216 "**Non-Structural Metal Framing**" for metal strap blocking in walls.
 3. Section 12 9000 "**Building Accessories**" for coat hooks for spaces other than restrooms.

1.3 SUBMITTALS

- A. **Product Data:** Include construction details, material descriptions and thicknesses, dimensions, profiles, fastening and mounting methods, specified options, and finishes for each type of accessory specified.
- B. **Samples:** For each accessory item to verify design, operation, and finish requirements.
 1. Approved full-size Samples will be returned and may be used in the Work.
- C. **Setting Drawings:** For cutouts required in other work; include templates, substrate preparation instructions, and directions for preparing cutouts and installing anchoring devices.
- D. **Product Schedule:** Indicating types, quantities, sizes, and installation locations by room of each accessory required. Use designations indicated in the Toilet and Bath Accessory Schedule and room designations indicated on Drawings in product schedule.
- E. **Maintenance Data:** For accessories to include in maintenance manuals specified in Division 1. Provide lists of replacement parts and service recommendations.

1.4 QUALITY ASSURANCE

- A. **Source Limitations:** Provide products of same manufacturer for each type of accessory unit and for units exposed to view in same areas, unless otherwise approved by Architect.
- B. **Product Options:** Accessory requirements, including those for materials, finishes, dimensions, capacities, and performance, are established by specific products indicated in the Toilet and Bath Accessory Schedule.
 - 1. Products of other manufacturers listed in Part 2 with equal characteristics, as judged solely by Architect, may be provided.
 - 2. Do not modify aesthetic effects, as judged solely by Architect, except with Architect's approval. Where modifications are proposed, submit comprehensive explanatory data to Architect for review.

1.5 COORDINATION

- A. **Coordinate accessory locations** with other work to prevent interference with clearances required for access by disabled persons, proper installation, adjustment, operation, cleaning, and servicing of accessories.
- B. **Deliver inserts** and anchoring devices set into concrete or masonry as required to prevent delaying the Work.

1.6 WARRANTY

- A. **General Warranty:** Special warranty specified in this Article shall not deprive Owner of other rights Owner may have under other provisions of the Contract Documents and shall be in addition to, and run concurrent with, other warranties made by Contractor under requirements of the Contract Documents.
- B. **Manufacturer's Mirror Warranty:** Written warranty, executed by mirror manufacturer agreeing to replace mirrors that develop visible silver spoilage defects within minimum warranty period indicated.
 - 1. Minimum Warranty Period: 15 years from date of Substantial Completion.

PART 2 - PRODUCTS

2.1 MANUFACTURERS

- A. **Available Manufacturers:** Subject to compliance with requirements of Contract Documents, manufacturers offering products that may be incorporated into the Work include, but are not limited to, the following:
 - 1. Toilet and Bath Accessories:
 - a. A & J Washroom Accessories, Inc.
 - b. American Specialties, Inc.
 - c. Bobrick Washroom Equipment, Inc.
 - d. Bradley Corporation.
 - 2. Underlavatory Guards:
 - a. IPS Corporation/Truebro.
 - b. Plumberex Specialty Products, Inc.

2.2 MATERIALS

- A. **Stainless Steel:** ASTM A 666, Type 304, with No. 4 finish (satin), in 0.0312-inch minimum nominal thickness, unless otherwise indicated.

- B. **Brass:** ASTM B 19, leaded and unleaded flat products; ASTM B 16, rods, shapes, forgings, and flat products with finished edges; ASTM B 30, castings.
- C. **Sheet Steel:** ASTM A 366/A 366M, cold rolled, commercial quality, 0.0359-inch minimum nominal thickness; surface preparation and metal pretreatment as required for applied finish.
- D. **Galvanized Steel Sheet:** ASTM A 653/A 653M, G60.
- E. **Chromium Plating:** ASTM B 456, Service Condition Number SC 2 (moderate service), nickel plus chromium electrodeposited on base metal.
- F. **Baked-Enamel Finish:** Factory-applied, gloss-white, baked-acrylic-enamel coating.
- G. **Mirror Glass:** ASTM C 1036, Type I, Class 1, Quality q2, nominal 6.0 mm thick, with silvering, electroplated copper coating, and protective organic coating complying with FS DD-M-411.
- H. **Galvanized Steel Mounting Devices:** ASTM A 153/A 153M, hot-dip galvanized after fabrication.
- I. **Fasteners:** Screws, bolts, and other devices of same material as accessory unit, tamper and theft resistant when exposed, and of galvanized steel when concealed.

2.3 FABRICATION

- A. **General:** Names or labels are not permitted on exposed faces of accessories. On interior surface not exposed to view or on back surface of each accessory, provide printed, waterproof label or stamped nameplate indicating manufacturer's name and product model number.
- B. **Surface-Mounted Toilet Accessories:** Unless otherwise indicated, fabricate units with tight seams and joints, and exposed edges rolled. Hang doors and access panels with continuous stainless-steel hinge. Provide concealed anchorage where possible.
- C. **Recessed Toilet Accessories:** Unless otherwise indicated, fabricate units of all-welded construction, without mitered corners. Hang doors and access panels with full-length, stainless-steel hinge. Provide anchorage that is fully concealed when unit is closed.
- D. **Framed Glass-Mirror Units:** Fabricate frames for glass-mirror units to accommodate glass edge protection material. Provide mirror backing and support system that permits rigid, tamper-resistant glass installation and prevents moisture accumulation.
 - 1. Provide galvanized steel backing sheet, not less than 0.034 inch and full mirror size, with non-absorptive filler material. Corrugated cardboard is not an acceptable filler material.
- E. **Mirror-Unit Hangers:** Provide mirror-unit mounting system that permits rigid, tamper- and theft-resistant installation, as follows:
 - 1. Heavy-duty wall brackets of galvanized steel, equipped with concealed locking devices requiring a special tool to remove.
- F. **Keys:** Provide universal keys for internal access to accessories for servicing and resupplying. Provide minimum of six keys to Owner's representative.

PART 3 - EXECUTION

3.1 INSTALLATION

- A. **Install accessories according to manufacturers' written instructions**, using fasteners appropriate to substrate indicated and recommended by unit manufacturer. Install units level, plumb, and firmly anchored in locations and at heights indicated.
- B. **Secure mirrors** to walls in concealed, tamper-resistant manner with special hangers, toggle bolts, or screws. Set units level, plumb, and square at locations indicated, according to manufacturer's written instructions for substrate indicated.
- C. **Install grab bars** to withstand a downward load of at least 250 lbf, when tested according to method in ASTM F 446.
- D. **Provide blocking and wall supports for all toilet accessories**, whether provided by Contractor or Owner. Verify locations and requirements of Owner-furnished equipment and provide necessary blocking.

3.2 ADJUSTING AND CLEANING

- A. **Adjust accessories** for unencumbered, smooth operation and verify that mechanisms function properly. Replace damaged or defective items.
- B. **Remove temporary labels** and protective coatings.
- C. **Clean and polish** exposed surfaces according to manufacturer's written recommendations.

3.3 TOILET AND BATH ACCESSORY SCHEDULE

- A. **Toilet Tissue Dispenser:**
 - 1. Furnished by Owner and installed by Contractor.
 - 2. Dispensers are Georgia Pacific "Compact" coreless double roll type - verify blocking and attachment requirements with Owner.
- B. **Toilet Seat Cover Dispenser:**
 - 1. Furnished by Owner and installed by Contractor - verify blocking and attachment requirements with Owner.
- C. **Towel Dispenser (Single Towel):**
 - 1. Furnished by Owner and installed by Contractor - verify blocking and attachment requirements with Owner.
- D. **Towel Dispenser (Motorized Roll):**
 - 1. Furnished by Owner and installed by Contractor.
 - 2. Roll type dispensers are Georgia Pacific "enMotion" automated type - verify blocking and attachment requirements with Owner.
- E. **Soap Dispenser:**
 - 1. Furnished by Owner and installed by Contractor.
 - 2. Soap dispensers are Dial Model 22 800ml capacity - verify blocking and attachment requirements with Owner.

- F. **Grab Bar:**
1. Basis of Design: Bobrick, B-6806 Series; lengths as indicated on the Drawings.
 2. Stainless-Steel Nominal Thickness: Minimum 0.05 inch.
 3. Mounting: Concealed with manufacturer's standard flanges and anchors.
 4. Gripping Surfaces: Manufacturer's standard slip-resistant texture.
 5. Outside Diameter: 1-1/2 inches for heavy-duty applications.
- G. **Sanitary Napkin Disposal Unit:**
1. Basis of Design: Bobrick, B-270.
 2. Surface-mounted, seamless exposed walls; self-closing top cover; locking bottom panel with stainless-steel, continuous hinge; and removable, reusable receptacle.
- H. **Shelf Unit:**
1. Basis of Design: Bobrick, B-298.
 2. Utility Shelf: 24-inch- long by 8-inch- deep shelf fabricated of minimum nominal 0.05-inch- thick stainless steel, with exposed edges turned down not less than 3/4 inch and supported by two triangular brackets welded to underside.
- I. **Under-Lavatory Guard**
1. Insulating Piping Coverings: White, antimicrobial, molded-vinyl covering for supply and drain piping assemblies intended for use at accessible lavatories to prevent direct contact with and burns from piping. Provide components as required for applications indicated with flip tops at valves that allow service access without removing coverings.
- J. **Mirror Unit:**
1. Basis of Design: Bobrick, B-290 Series, custom sized.
 2. One-piece, type 304 stainless steel angle frame, 3/4 inch x 3/4 inch with continuous integral stiffener on all sides and beveled front to hold frame tightly against mirror; corners shall be heliarc welded, ground, and polished smooth; all exposed surfaces shall have satin finish with vertical grain. Reflective surfaces shall be guaranteed for 15 years against silver spoilage. All edges shall be protected by plastic filler strips and the back shall be protected by full-size, shock-absorbing, water-resistant, nonabrasive, 3/16 inch thick polyethylene padding. Galvanized steel back shall have integral horizontal hanging brackets located at top and bottom for mounting on concealed rectangular wall hanger and to prevent the mirror from pulling away from the wall. Locking devices secure mirror to concealed wall hanger. Mirror shall be removable from wall hanger for reglazing.
 3. Sizes: As indicated on Drawings but not less than 24 inches x 44 inches.
- K. **Clothes Hook:**
1. Basis of Design: Bobrick, B- 76727.
 2. Surface-Mounted Double Robe Hook
 - a. Flange & Support Arm: 18-8 S, type 304 22 gauge stainless steel. Concealed, 18 gauge stainless steel mounting bracket. All welded construction. Secured to wall plate with a stainless steel setscrew.
 - b. Concealed Wall Plate: 18-8 S, type 304 19 gauge stainless steel.
 - c. Cap: 18-8 S, type 304 14 gauge stainless steel. Welded to the support arm.

L. **Specimen Pass-thru**

1. Basis of Design: Bobrick, B-50517
2. Recessed, with 2 interlocking doors to prevent opening of both doors at same time; Type 304 stainless steel with satin-finish, welded and polished. Unit shall comply with ADA-ABA, ICC/ANSI A117.1 for operation with one hand with less than 5 pounds of force without tight grasping, pinching or twisting of the wrist. Provide spillage tray and adjustable wall flange. Door secured to cabinet with a full-length stainless steel piano-hinge.

END OF SECTION

SECTION 10 4400

FIRE PROTECTION SPECIALTIES

PART 1 - GENERAL

1.1 RELATED DOCUMENTS

- A. Drawings and general provisions of the Contract, including General and Supplementary Conditions and Division 1 Specification Sections, apply to this Section.

1.2 SUMMARY

- A. **This Section includes:**
 - 1. Portable fire extinguishers:
 - a. Multipurpose dry chemical type.
 - 2. Fire protection cabinets for Portable fire extinguishers:
 - 3. Fire protection accessories.

1.3 SUBMITTALS

- A. **Product Data:** Include construction details, material descriptions, dimensions of individual components and profiles, and finishes for fire protection specialties.
 - 1. Fire Extinguishers: Include rating and classification.
 - 2. Cabinets: Include roughing-in dimensions, details showing mounting methods, relationships of box and trim to surrounding construction, door hardware, cabinet type, trim style, and panel style.
- B. **Samples for Selection:** Manufacturer's color charts consisting of units or sections of units showing the full range of colors, textures, and patterns available for each type of cabinet finish indicated.

1.4 QUALITY ASSURANCE

- A. **Source Limitations:** Obtain fire extinguishers and cabinets through one source from a single manufacturer.
- B. **NFPA Compliance:** Fabricate and label fire extinguishers to comply with NFPA 10, "Standard for Portable Fire Extinguishers."
- C. **Fire Extinguishers:** Listed and labeled for type, rating, and classification by an independent testing agency acceptable to authorities having jurisdiction.

1.5 COORDINATION

- A. Coordinate size of cabinets to ensure that type and capacity of fire extinguishers indicated are accommodated.

PART 2 - PRODUCTS

2.1 MANUFACTURERS

- A. **Basis of Design:** Contract Documents are based on products specified below to establish a standard of quality. Other available manufacturers with products having equivalent characteristics may be considered, provided deviations are minor and design concept as expressed in the Contract Documents is not changed, as judged by the Architect.
1. Manufacturer: J.L. Industries, Inc., a division of Activar Construction Products Group.
 2. Product: Cosmopolitan, 1037W10
- B. **Available Manufacturers:** Subject to compliance with requirements of Contract Documents, manufacturers offering products that may be incorporated into the Work include, but are not limited to, the following:
1. Portable Fire Extinguishers:
 - a. Badger; Div. of Figgie Fire Protection Systems.
 - b. Buckeye Fire Equipment Company.
 2. Fire Protection Cabinets:
 - a. J.L. Industries, Inc., a division of Activar Construction Products Group.
 - b. Larsen's Manufacturing Company; A member of Morris Group International.
 - c. Potter-Roemer; A member of Morris Group International.

2.2 MATERIALS

- A. **Cold-Rolled Steel Sheet:** Carbon steel, complying with ASTM A 366/A 366M, commercial quality, stretcher leveled, temper rolled.

2.3 PORTABLE FIRE EXTINGUISHERS

- A. **General:** Provide fire extinguishers as indicated in the Summary above.
- B. **Multipurpose Dry-Chemical Type:** UL-rated 4-A:60-B:C, 10-lb nominal capacity, in enameled-steel container.
- C. **Wet-Chemical Type:** UL-rated 2-A:1-B:C:K, 1.6-gal. nominal capacity, with potassium acetate-based chemical in stainless-steel container; with pressure-indicating gage.

2.4 FIRE PROTECTION CABINETS

- A. **Cabinet Construction:** Provide manufacturer's standard box (tub), with trim, frame, door, and hardware to suit cabinet type, trim style, and door style indicated. Weld joints and grind smooth. Miter and weld perimeter door frames.
1. Cabinet Metal: Enameled steel sheet.
- B. **Cabinet Type:** Suitable for fire extinguisher.
- C. **Cabinet Mounting:** Suitable for the following mounting conditions:
1. Semi-Recessed: Cabinet box recessed in walls of sufficient depth to suit style of trim indicated.

- D. **Cabinet Trim Style:** Fabricate cabinet trim in one piece with corners mitered, welded, and ground smooth.
 - 1. Exposed Trim: One-piece combination trim and perimeter door frame overlapping surrounding wall surface with exposed trim face and wall return at outer edge (backbend)
- E. **Cabinet Trim Material:** Stainless steel; finish US4.
- F. **Door Material:** Stainless steel.
- G. **Door Glazing:** Clear, smooth acrylic; 4 mm thick.
- H. **Door Style:** Vertical acrylic panel with frame.
- I. **Door Construction:** Fabricate doors according to manufacturer's standards, of materials indicated, and coordinated with cabinet types and trim styles selected.
 - 1. Provide minimum 1/2-inch- thick door frames, fabricated with tubular stiles and rails, and hollow-metal design.
- J. **Door Hardware:** Provide manufacturer's standard door-operating hardware of proper type for cabinet type, trim style, and door material and style indicated.
 - 1. Pull handle: Manufacturer's standard loop handle; zinc.
 - 2. Lock: Theft-deterrent system; break-away replaceable plastic cam on keyed cylinder lock; coordinate keying with Owner; furnish 2 extra cams per cabinet with installation; JL Industries "Saf-T-Lok" or equivalent as judged by the Architect.
 - 3. Hinge: Continuous-type hinge permitting door to open 180 degrees.

2.5 ACCESSORIES

- A. **Mounting Brackets:** Manufacturer's standard steel, designed to secure extinguisher, of sizes required for types and capacities of extinguishers indicated, with plated or baked-enamel finish.
 - 1. Provide brackets for extinguishers not located in cabinets.
 - 2. Provide brackets for extinguishers located in cabinets.
- B. **Door Locks:** Provide cylinder lock, with all cabinets keyed alike.
- C. **Identification:** Provide lettering to comply with authorities having jurisdiction for letter style, color, size, spacing, and location. Locate as indicated by Architect.
 - 1. Identify bracket-mounted extinguishers with the words "FIRE EXTINGUISHER" in red letter decals applied to wall surface.
 - 2. Identify fire extinguisher in cabinet with the words "FIRE EXTINGUISHER" applied to door.
 - a. Application Process: Silk-screened.
 - b. Lettering Color: Red.
 - c. Orientation: Vertical.

2.6 COLORS AND TEXTURES

- A. **Colors and Textures:** As selected by Architect from manufacturer's full range for these characteristics.

2.7 FINISHES, GENERAL

- A. **Comply with NAAMM's** "Metal Finishes Manual for Architectural and Metal Products" for recommendations for applying and designating finishes.
- B. **Protect mechanical finishes** on exposed surfaces from damage by applying a strippable, temporary protective covering before shipping.
- C. **Appearance of Finished Work:** Variations in appearance of abutting or adjacent pieces are acceptable if they are within one-half of the range of approved Samples. Noticeable variations in the same piece are not acceptable. Variations in appearance of other components are acceptable if they are within the range of approved Samples and are assembled or installed to minimize contrast.
- D. **Cabinet and Door Finishes:** Provide manufacturer's standard baked-enamel paint for the interior of cabinets.
 - 1. Exterior of cabinets and doors to be stainless steel.

2.8 STEEL FINISHES

- A. **Surface Preparation:** Clean surfaces of dirt, oil, grease, mill scale, rust, and other contaminants that could impair paint bond using manufacturer's standard methods.
- B. Provide a **stainless steel** finish; US 4 on exposed exterior surfaces.

PART 3 - EXECUTION

3.1 EXAMINATION

- A. **Examine walls** and partitions for suitable framing depth and blocking where fully-recessed cabinets are to be installed.
- B. **Examine fire extinguishers** for proper charging and tagging.
 - 1. Remove and replace damaged, defective, or undercharged units.
- C. **Proceed** with installation only after unsatisfactory conditions have been corrected.

3.2 INSTALLATION

- A. **Comply** with manufacturer's written instructions for installing fire protection specialties.
- B. **Install in locations** and at mounting heights indicated or, if not indicated, at heights acceptable to authorities having jurisdiction.
 - 1. Prepare recesses for cabinets as required by type and size of cabinet and trim style.
 - 2. Fasten mounting brackets to structure and cabinets, square and plumb.
 - 3. Fasten cabinets to structure, square and plumb.

3.3 ADJUSTING, CLEANING, AND PROTECTION

- A. **Adjust** cabinet doors that do not swing or operate freely.
- B. **Refinish or replace** cabinets and doors damaged during installation.

- C. **Provide final protection** and maintain conditions that ensure that cabinets and doors are without damage or deterioration at the time of Substantial Completion.

END OF SECTION

THIS PAGE LEFT BLANK INTENTIONALLY

DIVISION 11 – EQUIPMENT

Section 11 7013
Section 11 7014

Medical Equipment
Equipment Schedule

THIS PAGE LEFT BLANK INTENTIONALLY

SECTION 11 7013
MEDICAL EQUIPMENT

PART 1 - GENERAL

1.1 RELATED DOCUMENTS

- A. Drawings and general provisions of the Contract, including General and Supplementary Conditions and Division 01 Specification Sections, apply to this Section.

1.2 SUMMARY

- A. **Section Includes:**
1. Medical equipment, furnished by Owner and installed by Contractor, as outlined in Schedules and on Drawings.
 2. Toilet accessories, furnished by Owner and installed by Contractor, as outlined in Schedules and on Drawings.
 3. Medical equipment, furnished and installed by Owner, as outline in Schedules and on Drawings. Contractor shall coordinate power receptacles and other services for Owner-furnished and installed equipment.
- B. **Owner-Furnished Equipment:** Where indicated, Owner will furnish equipment for installation by Contractor.
- C. **Related Sections:**
1. Section 06 4023 **"Interior Architectural Woodwork"** for requirements for tackboards and other items noted in Medical Equipment Schedules to be provided by Contractor to accommodate medical equipment.
 2. Section 10 2800 **"Toilet and Bath Accessories"** for toilet accessories provided by Contractor.

1.3 PROJECT CONDITIONS

- A. **Field Measurements:** Verify actual dimensions of construction by field measurements before fabrication or installation.

1.4 COORDINATION

- A. **Coordinate equipment layout and installation** with other work, including layout and installation of lighting fixtures, HVAC equipment, and fire-suppression system components.
- B. **Coordinate** locations and requirements of utility **service connections**.

PART 2 - PRODUCTS

2.1 MEDICAL EQUIPMENT

- A. See Drawings and technical specification sections for scope of items to be provided by Contractor as well as items to be furnished by Owner and installed by Contractor.

PART 3 - EXECUTION

3.1 PREPARATION

- A. **Obtain manufacturer's written installation instructions** for all Owner-furnished/Contractor-installed equipment prior to hanging gypsum board.
- B. **Provide blocking** in walls where required by manufacturer's installation instructions and as required to assure equipment can be permanently secured where indicated on Drawings.

3.2 INSTALLATION

- A. **Install equipment level and plumb**, according to manufacturer's written instructions.
 - 1. Connect equipment to utilities.
 - 2. Provide cutouts in equipment, neatly formed, where required to run service lines through equipment to make final connections.
- B. **Complete equipment assembly** where field assembly is required.
- C. **Install equipment with access and maintenance clearances** that comply with manufacturer's written installation instructions and with requirements of authorities having jurisdiction.
- D. **Install closure-trim strips** and similar items requiring fasteners in a bed of sealant.
- E. **Install joint sealant in joints** between equipment and abutting surfaces with continuous joint backing unless otherwise indicated.

3.3 CLEANING AND PROTECTING

- A. After completing installation of equipment, repair damaged finishes.
- B. Clean and adjust equipment as required to produce ready-for-use condition.
- C. Protect equipment from damage during remainder of the construction period.

END OF SECTION

**RIVERTON HOSPITAL - DUAL AMBULATORY SURGICAL CENTER
HOSPITAL**

EQUIPMENT & FURNITURE SCHEDULE



LEVEL 2 - SURGICAL SERVICES																			
QUANTITY - TOTAL	(ATA 3 ID)	EQUIPMENT CODE	DESCRIPTION	MODEL NAME / NUMBER	MANUFACTURER	SIZE			FLOOR (F) / BASE CABINET (B) / WALL (W) / CEILING (C) / MOBILE (M)	MECHANICAL / PLUMBING			ELECTRICAL			CONTRACTOR (C) OWNER (O) VENDOR (V)			
						WIDTH	DEPTH	HEIGHT		OTHER	DRAIN	COLD WATER	HOT WATER	VOLTS	AMPS (A) / WATTS (W)	ALARM	EMERGENCY	DATA	NEW
1 CORRIDOR E2C26 (HEIGHT & WEIGHT ALCOVE)																			
1	SCL-543FF	SC8	INFANT SCALE W. CART	4802D	HILL-ROM / SCALETRONIX	28"	16"	7"		M	-	-	-	-	-	-	X	-	O
1	SCL-94061	SC10	WHEELCHAIR / BARIATRIC / STAND-ON SCALE - MOBILE	6002	SCALE-TRONIX (WELCH ALLYN)	35"	30"	34"		M	-	-	-	-	-	X	X	-	O
1	SDM-31A3E	SC15.1	INFANT STADIOMETER (w. MOBILE STAND)	SECA 417	SECA	47"	12"	48"		B	-	-	-	-	-	-	X	-	O/C
1	SDM-9800E	SC17	STADIOMETER (HEIGHT ROD - WALL)	MODEL S100	AYRTON	6"	9"	70"		W	-	-	-	-	-	-	X	-	O
1	DSPF282A	D14	ANTIMICROBIAL WALL BRACKET	AVAGARD	3M	4"	4"	9"		W	-	-	-	-	-	-	X	-	O
1	GLV-80326	D17	GLOVE BOX DISPENSER - TRIPLE	36728 SEMI-TRANSPARENT	HALYARD	12"	4"	15"		W	-	-	-	-	-	-	X	-	O
1	DSP-FAEFO	D17	DISINFECTANT WIPES DISPENSER - WALL MOUNTED	P010901 SANI BRACKET	PDI	6"	6"	9"		W	-	-	-	-	-	-	X	-	O
1	WST-F5ED9	WH11	WASTE RECEPTACLE - 18 GAL.	1883604	RUBBERMAID	11"	15"	15"		M	-	-	-	-	-	-	X	-	O
1	CLK-86C9A	CK1	CLOCK - WALL MOUNTED	B1004Z155	PRIMEX	17"		6"		W	-	-	-	-	-	-	X	-	O
1 NURSE STATION 2C30																			
4	-	CO2.1	COMPUTER WORKSTATION - SINGLE MONITOR (DESKTOP)	ALL-IN-ONE (22")	DELL	21"	3"	15"	22"Dm.	B	-	-	-	-	-	-	X	-	O
4	-	TE2	TELEPHONE							B	-	-	-	-	-	-	X	-	O
1	-	MU1.1	MULTIFUNCTION (PRINTER / SCANNER / FAX) - FLOOR	MX-B402	SHARP	23"	20"	29"		B	-	-	-	-	-	-	X	-	O
1	-	DS3	MEDICATION DISPENSING SYSTEM - QUARTER HEIGHT CABINET (COUNTER)	OMNICELL XT	OMNICELL	27"	27"	26"		M	-	-	-	-	-	-	X	-	O
1	DSP-UC366	1006.1	SOAP DISPENSER	7251	COLOPLAST	6"	5"	11"		W	-	-	-	-	-	-	X	-	O
1	DSP-Z76E6	1006.2	PAPER TOWEL DISPENSER	56650 C-FOLD	GEORGIA PACIFIC	11"	6"	16"		W	-	-	-	-	-	-	X	-	O
1	DSP-F282A	D14	ANTIMICROBIAL WALL BRACKET	AVAGARD	3M	4"	4"	9"		W	-	-	-	-	-	-	X	-	O
1	GLV-80326	D17	GLOVE BOX DISPENSER - TRIPLE	GP-330	BOWMAN	12"	4"	15"		W	-	-	-	-	-	-	X	-	O
4	WST-7A241	WH11	WASTE RECEPTACLE - 7 GAL.	2956	RUBBERMAID	11"	15"	15"		M	-	-	-	-	-	-	X	-	O
1	WST-822B6	WH8	RECYCLING RECEPTACLE - 10.3 GAL.	FG354007GR	RUBBERMAID	11"	16"	20"		M	-	-	-	-	-	-	X	-	O
1	CLK-86C9A	CK1	CLOCK - WALL MOUNTED	B1004Z155	PRIMEX	17"		6"		W	-	-	-	-	-	-	X	-	O
4	-	-	CHAIRS (OFFICE)							M	-	-	-	-	-	-	X	-	O
1 CLEAN SUPPLY 2C31																			
3	CA10.1	CA10.1	SUPPLY CART-WIRE SHELVING (24X48)	A2448NC - SUPER ADJUSTABLE-SUPER ERECTA	METRO CARTS	48"	24"	68"		M	-	-	-	-	-	-	X	-	O
4 PRE-OP #5 2C27, PRE-OP #6 2C29, PRE-OP #7 2D01 & PRE-OP #8 2D02 [TOTAL = 4 ROOMS]																			
4	STR-RDE17	GU7	UNIVERSAL STRETCHER	7500-N-SPEC	PEDIGO	83"	34"	33"		M	-	-	-	-	-	-	X	-	O
4	LIG-3F84B	LI3	PATIENT MONITORING SYSTEM W. MOBILE STAND	INTELLIVUE MX450 - MOBILE	PHILIPS	13"	7"	42"		M	-	-	-	-	-	-	X	-	O
4	TOB-36615	TA14	EXAM / PROCEDURE LIGHT (LED) - SINGLE ARM - WALL MOUNTED	HEXALUX	STERS					C	-	-	-	-	-	-	X	-	O
4	TOB-36615	TA14	OVERBED TABLE	OB1635	HILL-ROM	38"	20"	47"		M	-	-	-	-	-	-	X	-	O
4	-	CO1	WALL MOUNTED COMPUTER - ALL-IN-ONE	ALL-IN-ONE (22")	DELL	21"	3"	15"	22"D	W	-	-	-	-	-	-	X	-	O

4	1	-	WALL BRACKET - COMPUTER	LX WALL MOUNT SYSTEM	ERGOTRON	19"	4"	34"		W	-	-	-	-	-	-	-	-	-	-	X		PROVIDE WALL BACKING	X	-	0	C	
4	1	-	TELEPHONE (WALL)																			X	PROVIDE WALL BACKING	X	-	0	O	
4	1	-	SCANNER - BARCODE (HANDHELD)							B	-	-	-	120V	-	-	-	-	-	-	X				-	0	O	
4	1	IDS-ETEB9	DIAGNOSTIC BOARD + BLOOD PRESSURE + THERMOMETER	777 W. SURETEMP	WELCH ALLYN	40"	12"			W	-	-	-	120V	-	-	-	-	-	-	-		PROVIDE WALL BACKING	X	-	0	C	
4	1	FLW-F8154	OXYGEN FLOWMETER							W	-	-	-	-	-	-	-	-	-	-	-				-	0	C	
4	1	FLW-24889	MEDICAL AIR FLOWMETER							W	-	-	-	-	-	-	-	-	-	-	-				-	0	C	
4	1	REG-F15DC	MEDICAL VACUUM FLOWMETER							W	-	-	-	-	-	-	-	-	-	-	-				-	0	C	
4	1	BRK-389CE	SUCTION CANISTER							W	-	-	-	-	-	-	-	-	-	-	-				-	0	C	
4	1	PRC-FD9E9	EXAM / PROCEDURE CART (6 DRAWERS)	SXRS2220L	INTERMETRO	35"	26"	39"		M	-	-	-	-	-	-	-	-	-	-	-				-	0	O	
4	1	STL-CD120	PHYSICIAN STOOL	BITTER 272	MIDMARK			18"	16"D	M	-	-	-	-	-	-	-	-	-	-	-				-	0	O	
4	1	IVS-088AE	IV POLE	HITCH N PAL 811	PRYOR			72"	22"Dm.	M	-	-	-	-	-	-	-	-	-	-	-				-	0	O	
4	1	DSP-0C366	SOAP DISPENSER	7251	COLOPLAST	6"	5"	11"		W	-	-	-	-	-	-	-	-	-	-	-		(AT HANDWASH STATIONS)	X	-	0	O	
4	1	DSP-276E6	PAPER TOWEL DISPENSER	56650 C-FOLD	GEORGIA PACIFIC	11"	6"	16"		W	-	-	-	-	-	-	-	-	-	-	-		(AT HANDWASH STATIONS)	X	-	0	O	
4	1	DSP-F282A	ANTIMICROBIAL WALL BRACKET	AVAGARD	3M	4"	4"	9"		W	-	-	-	-	-	-	-	-	-	-	-				-	0	C	
4	1	GLV-80326	GLOVE BOX DISPENSER - TRIPLE	GP-330	BOWMAN	12"	4"	15"		W	-	-	-	-	-	-	-	-	-	-	-				-	0	C	
4	1	DSP-A26A8	EMESIS BAG DISPENSER - WALL	MEB393D	MEDLINE	7"	7"	8"		W	-	-	-	-	-	-	-	-	-	-	-				-	0	C	
4	1	DSP-FAEF0	DISINFECTANT WIPES DISPENSER - WALL MOUNTED	P010901 SANI BRACKET	PDI	6"	6"	9"		W	-	-	-	-	-	-	-	-	-	-	-				-	0	C	
4	1	-	COAT / HAT RACK	B-7672	BOBRICK	4"	2"	2"		W	-	-	-	-	-	-	-	-	-	-	-				-	0	C	
4	1	WST-B1945	BIOHAZARD WASTE - SQUARE STEEL CAN (8 GAL.)	35267	BREWER	13"	12"	19"		M	-	-	-	-	-	-	-	-	-	-	-				-	0	O	
4	1	HAM-09F0	LINEN HAMPER	CX102 LARGE	CENTURION	24"	24"	32"	19"D	M	-	-	-	-	-	-	-	-	-	-	-				-	0	O	
4	1	DIS-8947C	SHARPS RECEPTACLE w. LOCKING CABINET (4 GAL.)	C-04RES-04-0C	STEROCYCLE	15"	6"	14"		W	-	-	-	-	-	-	-	-	-	-	-		(INSIDE CABINET)	X	-	0	O	
4	1	WST-HE00D	WASTE RECEPTACLE - 23 GAL. (SLIM JIM)	3540 (SLIM JIM)	RUBBERMAID	11"	16"	20"		M	-	-	-	-	-	-	-	-	-	-	-				-	0	O	
4	1	CLK-46C9A	CLOCK - WALL MOUNTED	B1004Z165	PRIMEX	17"		6"		W	-	-	-	-	-	-	-	-	-	-	-				-	0	O	
8	2	-	CHAIRS (GUEST)							M	-	-	-	-	-	-	-	-	-	-	-				-	0	O	
1 PACU 2D03																												
	1	STR-8DE17	UNIVERSAL STRETCHER	7500-N-SPEC	PEDIGO	83"	34"	33"		M	-	-	-	-	-	-	-	-	-	-	-				X	-	0	O
	1	MON-6A8F7	PATIENT MONITOR (WALL)	INTELLIVUE MX450 W. X3	PHILIPS	13"	7"	12"		W	-	-	-	120V	-	-	-	-	-	-	-				X	-	0	O
	1	-	WALL BRACKET - PATIENT MONITOR	MX450 WH WALL	GCX					W	-	-	-	-	-	-	-	-	-	-	-		PROVIDE WALL BACKING	X	-	0	C	
	1	-	WALL MOUNTED COMPUTER - ALL-IN-ONE	ALL-IN-ONE (27)	DELL	21"	3"	15"	22" D	W	-	-	-	120V	-	-	-	-	-	-	X				X	-	0	O
	1	-	WALL BRACKET - COMPUTER	LX WALL MOUNT SYSTEM	ERGOTRON	19"	4"	34"		W	-	-	-	120V	-	-	-	-	-	-	X		PROVIDE WALL BACKING	X	-	0	C	
	1	-	TELEPHONE (WALL)											-	-	-	-	-	-	-	-				X	-	0	O
	1	-	SCANNER - BARCODE (HANDHELD)							B	-	-	-	120V	-	-	-	-	-	-	X				X	-	0	O
	1	IDS-ETEB9	DIAGNOSTIC BOARD + BLOOD PRESSURE + THERMOMETER	777 W. SURETEMP	WELCH ALLYN	40"	12"			W	-	-	-	120V	-	-	-	-	-	-	-		PROVIDE WALL BACKING	X	-	0	C	
	1	FLW-F8154	OXYGEN FLOWMETER							W	-	-	-	-	-	-	-	-	-	-	-				X	-	0	C
	1	FLW-24889	MEDICAL AIR FLOWMETER							W	-	-	-	-	-	-	-	-	-	-	-				X	-	0	C
	1	REG-F15DC	MEDICAL VACUUM FLOWMETER							W	-	-	-	-	-	-	-	-	-	-	-				X	-	0	C
	1	BRK-389CE	SUCTION CANISTER							W	-	-	-	-	-	-	-	-	-	-	-				X	-	0	C
	1	BSK-347C5	WIRE BASKET-WALL MOUNTED							W	-	-	-	-	-	-	-	-	-	-	-				X	-	0	O
	1	PRC-FD9E9	EXAM / PROCEDURE CART (6 DRAWERS)	SXRS2220L	INTERMETRO	35"	26"	39"		M	-	-	-	-	-	-	-	-	-	-	-				X	-	0	O
	1	STL-CD120	PHYSICIAN STOOL	BITTER 272	MIDMARK			18"	16"D	M	-	-	-	-	-	-	-	-	-	-	-				X	-	0	O
	1	IVS-088AE	IV POLE	HITCH N PAL 811	PRYOR			72"	22"Dm.	M	-	-	-	-	-	-	-	-	-	-	-				X	-	0	O
	1	DSP-0C366	SOAP DISPENSER	7251	COLOPLAST	6"	5"	11"		W	-	-	-	-	-	-	-	-	-	-	-		(AT HANDWASH STATIONS)	X	-	0	O	
	1	DSP-276E6	PAPER TOWEL DISPENSER	56650 C-FOLD	GEORGIA PACIFIC	11"	6"	16"		W	-	-	-	-	-	-	-	-	-	-	-		(AT HANDWASH STATIONS)	X	-	0	O	
	1	DSP-F282A	ANTIMICROBIAL WALL BRACKET	AVAGARD	3M	4"	4"	9"		W	-	-	-	-	-	-	-	-	-	-	-				X	-	0	C
	1	GLV-80326	GLOVE BOX DISPENSER - TRIPLE	GP-330	BOWMAN	12"	4"	15"		W	-	-	-	-	-	-	-	-	-	-	-				X	-	0	C
	1	DSP-A26A8	EMESIS BAG DISPENSER - WALL	MEB393D	MEDLINE	7"	7"	8"		W	-	-	-	-	-	-	-	-	-	-	-				X	-	0	C
	1	DSP-FAEF0	DISINFECTANT WIPES DISPENSER - WALL MOUNTED	P010901 SANI BRACKET	PDI	6"	6"	9"		W	-	-	-	-	-	-	-	-	-	-	-				X	-	0	C
	1	-	COAT / HAT RACK	B-7672	BOBRICK	4"	2"	2"		W	-	-	-	-	-	-	-	-	-	-	-				X	-	0	C

1	WST-B1945	WH332	BIOHAZARD WASTE - SQUARE STEEL CAN (8 GAL.)	35267	BREWER	13"	12"	19"		M	-	-	-	-	-	-	-	-	-	X	-	0	0
1	HAM-09F0	WH2	LINEN HAMPER	CX102 LARG	CENTURION	24"	24"	32"	19" D	M	-	-	-	-	-	-	-	-	-	X	-	0	0
1	DIS-8947C	WH3	SHARPS RECEPTACLE w. LOCKING CABINET (4 GAL.)	C-04RES-04-0C	STERICYCLE	15"	6"	14"		W	-	-	-	-	-	-	-	-	-	X	-	0	0
1	WST-4E00D	WH2	WASTE RECEPTACLE - 23 GAL. (SLIM JIM)	3540 (SLIM JIM)	RUBBERMAID	11"	16"	20"		M	-	-	-	-	-	-	-	-	-	X	-	0	0
1	CLK-A6C9A	CK1	CLOCK - WALL MOUNTED	B1004Z155	PRIMEX	17"		6"		W	-	-	-	-	-	-	-	-	-	X	-	0	0
1	-		CHAIRS (GUEST)							M	-	-	-	-	-	-	-	-	-	X	-	0	0
1 GENERAL OPERATING ROOM #2 E2D27																							
1	TBS-5DF0	TA12	SURGICAL TABLE	AMSCO 3085 SP	STERIS	25"	76"	44"		M	-	-	-	-	-	-	-	-	-	X	-	0	0
2	B08.1	B08.1	BOOM-TANDEM-EQUIPMENT + MONITOR (OR)	HARMONY AIR	STERIS					C	-	-	-	120V	-	-	-	-	-	X	-	0	0
1	BOM-32ZEB	B04	SURGICAL BOOM - ANESTHESIA	HARMONY AIR	STERIS					C	-	-	-	120V	-	-	-	-	-	X	-	0	0
1	ANE-0770D	AT2	ANESTHESIA DELIVERY MACHINE	AISYS CS2	GE	27"	33"	75"		M	-	-	-	120V	-	-	-	-	-	X	-	0	0
1	ANC-81E94	CA20	ANESTHESIA CART - UNIVERSAL	6351	HARLOFF	26"	33"	47"		M	-	-	-	120V	-	-	-	-	-	X	-	0	0
1	EOC-C5148	WA10	HYPERHERMIA UNIT - MOBILE	BAIR HUGGER 505	3M	16"	16"	17"		B	-	-	-	120V	-	-	-	-	-	X	-	0	0
1	-	CO2.1	COMPUTER WORKSTATION - SINGLE MONITOR (DESKTOP)	ALL-IN-ONE (27")	DELL	21"	3"	15"	22" Dm.	B	-	-	-	120V	-	-	-	-	-	X	-	0	0
1	-	CO2.2	COMPUTER WORKSTATION - DUAL MONITOR (DESKTOP)	ALL-IN-ONE (27")	DELL	42"	3"	15"	22" Dm.	B	-	-	-	120V	-	-	-	-	-	X	-	0	0
2	-	TE1	TELEPHONE (WALL)								-	-	-	-	-	-	-	-	-		-	-	-
1	-	PR1	DESKTOP PRINTER	LASERJET ENTERPRISE M605n	HEWLETT PACKARD	17"	18"	16"		B	-	-	-	120V	-	-	-	-	-	X	-	0	0
2	-	PR4	PRINTER - LABEL	GX420	ZEBRA	7"	9"	6"		B	-	-	-	120V	-	-	-	-	-	X	-	0	0
1	-	SN4	SCANNER - BARCODE (HANDHELD)							B	-	-	-	120V	-	-	-	-	-	X	-	0	0
1	-		SCANNER - SURGICOUNT (HANDHELD)							B	-	-	-	120V	-	-	-	-	-	X	-	0	0
2	FLW-F8154	O	OXYGEN FLOWMETER							W	-	-	-	-	-	-	-	-	-	X	-	0	0
1	FLW-24899	A	MEDICAL AIR FLOWMETER							W	-	-	-	-	-	-	-	-	-	X	-	0	0
3	REG-F15DC	V	MEDICAL VACUUM FLOWMETER							W	-	-	-	-	-	-	-	-	-	X	-	0	0
3	BRK-389CE	SC	SUCTION CANISTER							W	-	-	-	-	-	-	-	-	-	X	-	0	0
1	-	N2O	NITROUS OXIDE							W	-	-	-	-	-	-	-	-	-	X	-	0	0
1	-	WAGD	WASTE ANESTHESIA GAS DISPOSAL							W	-	-	-	-	-	-	-	-	-	X	-	0	0
1	-	WT14	WORKTABLE-FLAT TOP w. UNDERSHELF (S.S.) 24" X 60"	T2460SEB	EAGLE GROUP	24"	60"	36"		M	-	-	-	-	-	-	-	-	-	X	-	0	0
2	-	SL1	PHYSICIAN STOOL	RITTER 272	MIDMARK			18"	16" D	M	-	-	-	-	-	-	-	-	-	X	-	0	0
2	-	SL3	AIR LIFT PHYSICIAN STOOL (WITH BACK, 6" LAB EXTENSION & FOOT RING)	RITTER 277	MIDMARK			19"	19" Dm.	M	-	-	-	-	-	-	-	-	-	X	-	0	0
1	-		ANESTHESIA CHAIR w. ARMS		ARMSTRONG					M	-	-	-	-	-	-	-	-	-	X	-	0	0
1	STL-2C1F7	SL4	STEP STOOL	11220	BREWER	12"	15"	9"	19" Dm.	M	-	-	-	-	-	-	-	-	-	X	-	0	0
1	INF-39A21	SS2	INFUSION PUMP w. STAND	CAREFUSION ALARIS	BD					M	-	-	-	-	-	-	-	-	-	X	-	0	0
1	MAY-1882A	ST3	MAYO STAND-STAINLESS STEEL	P-66	PEDIGO	20"	13"	53"		M	-	-	-	-	-	-	-	-	-	X	-	0	0
1	-	ST8	STAINLESS STEEL STAND BASIN-SINGLE							M	-	-	-	-	-	-	-	-	-	X	-	0	0
1	IVS-088AE	ST9	HIGH FLOW IV POLE	HITCH N PAL 811	PRYOR			116"	22" Dm.	M	-	-	-	-	-	-	-	-	-	X	-	0	0
1	BRO-1B1FC	B04	PATIENT SLIDER-TRANSFER BOARD	HIGHTECH ROLLBOARD	SAMARIT MEDICAL	70"	20"	2"		W	-	-	-	-	-	-	-	-	-	X	-	0	0
1	DSP-F282A	D14	ANTIMICROBIAL WALL BRACKET	AVAGARD	3M	4"	4"	9"		W	-	-	-	-	-	-	-	-	-	X	-	0	0
1	GLV-60326	D17	GLOVE BOX DISPENSER - TRIPLE	GP-330	BOWMAN	12"	4"	15"		W	-	-	-	-	-	-	-	-	-	X	-	0	0
1	-	D16	EMESIS BAG DISPENSER - WALL	MEB883D	MEDLINE	7"	7"	8"		W	-	-	-	-	-	-	-	-	-	X	-	0	0
1	DSP-FAEFO	D27	DISINFECTANT WIPES DISPENSER - WALL MOUNTED	P010901 SANI BRACKET	PDI	6"	6"	9"		W	-	-	-	-	-	-	-	-	-	X	-	0	0
1	-	WH1	BIOHAZARD WASTE (13 GAL.)	1883566 SLIM JIM	RUBBERMAID	18"	12"	29"		M	-	-	-	-	-	-	-	-	-	X	-	0	0
2	HAM-9A75F	WH2	LINEN HAMPER	P-1120-L-SS	PEDIGO	24"	24"	32"	19" D	M	-	-	-	-	-	-	-	-	-	X	-	0	0
1	DIS-4CC7C	WH24	SHARP RECEPTACLE - FLOOR							W	-	-	-	-	-	-	-	-	-	X	-	0	0
1	BUK-F46EA	WH9	KICK BUCKET	P-1020-SS	PEDIGO	14"	14"	14"		M	-	-	-	-	-	-	-	-	-	X	-	0	0
1	WST-7A241	WH11	WASTE RECEPTACLE - 7 GAL.	2956	RUBBERMAID	11"	15"	15"		M	-	-	-	-	-	-	-	-	-	X	-	0	0
1	CLK-A6C9A	CK1	CLOCK - WALL MOUNTED	B1004Z155	PRIMEX	17"		6"		W	-	-	-	-	-	-	-	-	-	X	-	0	0
	HYP-ACE23		HYP-HYPERHERMIA UNIT (WHOLE BODY)	233 BLANKETROL III	GENTHERM-CSZ						-	-	-	-	-	-	-	-	-		-	-	-
	STL-16AC		EXAM STOOL (CUSHIONED)	P-528-GS-BLK	PEDIGO						-	-	-	-	-	-	-	-	-		-	-	-

THIS PAGE LEFT BLANK INTENTIONALLY

DIVISION 12 – FURNISHINGS

Section 12 9000

Building Accessories

THIS PAGE LEFT BLANK INTENTIONALLY

SECTION 12 9000
BUILDING ACCESSORIES

PART 1 - GENERAL

1.1 RELATED DOCUMENTS

- A. Drawings and general provisions of Contract, including General and Supplementary Conditions and Division 1 Specification Sections, apply to this Section.

1.2 SUMMARY

- A. This **section includes** the following:
 - 1. Coat hooks

1.3 SUBMITTALS

- A. **Product data** for each type of accessory specified, with installation instructions for each unit built-in or connected to other construction. Include methods of installation for each type of substrate.
- B. **Shop drawings** showing installation details of accessories permanently affixed to construction, including full scale installation details of special conditions.
- C. **Samples for initial selection** purposes consisting of manufacturer's standard size samples showing full range of colors, textures, and patterns available for each type of accessory required.

1.4 QUALITY ASSURANCE

- A. **Manufacturer Qualifications:** Firm (material producer) with not less than 3 years of production experience, whose published literature clearly indicates general compliance of products with requirements of this section.
- B. **Single Source Responsibility:** Provide material produced by a single manufacturer for each accessory type.

1.5 DELIVERY, STORAGE, AND HANDLING

- A. **Deliver materials to Project site** in original factory wrappings and containers, clearly labeled with identification of manufacturer, brand name, and lot number. Store materials in original undamaged packages and containers, inside well-ventilated area protected from weather, moisture, soiling, extreme temperatures, humidity; laid flat, blocked off ground to prevent sagging and warping.
- B. **Comply with instructions and recommendations** of manufacturer for special delivery, storage, and handling requirements.

1.6 SEQUENCE AND SCHEDULING

- A. **Sequence accessory installation** with other work to minimize possibility of damage and soiling during remainder of construction period.

1.7 MAINTENANCE

- A. **Maintenance Instructions:** Submit manufacturer's printed instructions for maintenance of installed work, including methods and frequency recommended for maintaining optimum condition under anticipated use conditions. Include precautions against materials and method which may be detrimental to finishes and performance.

PART 2 - PRODUCTS

2.1 MATERIALS

- A. **Fasteners:** Screws, bolts or other exposed devices of same material as accessory unit, or of galvanized steel where concealed. Equip items with theft-proof fasteners where accessible to tampering.

2.2 FABRICATION, GENERAL

- A. **Provide accessory items,** permanently installed, equipped with functions as specified. Fabricate units with tight seams and joints, exposed metal edges rolled. Manufacturer or product identification on exposed surfaces is unacceptable. Provide products with smooth welds, consistent finish with no evidence of wrinkling, chipping, uneven coloration, dents, or other imperfections.

2.3 COAT HOOKS

- A. **Manufacturer:** Subject to compliance with requirements of Contract Documents, provide product by the following manufacturer:
 - 1. Manufacturer: Umbra; www.umbra.com.
 - 2. Product: "flip hook".
- B. **Properties:**
 - 1. Wall mounted hardwood with five flip-down hooks, overall weight limit: 60 lb.
 - 2. Wood Finish: As selected by Architect from manufacturer's full range.
 - 3. Metal Finish: Brushed nickel-plate.

PART 3 - EXECUTION

3.1 INSTALLATION

- A. **Verify** that materials are those specified before installing.
- B. **Install accessories** after other finishing operations, including painting, have been completed.
- C. **Permanently Placed Equipment and Components:** Rigid, level, plumb, square, and true; anchored securely to supporting structure; positioned at locations and elevations indicated on Shop Drawings; in proper relation to adjacent construction; and aligned with room layout.
- D. **Anchoring to In-Place Construction:** Use anchors and fasteners where necessary for securing built-in and permanently placed equipment and components to structural support and for properly transferring load to in-place construction.
- E. **Adjust accessory items** for proper operation. Clean and polish exposed surfaces, using materials and methods recommended by the manufacturer.

3.2 PROTECTION

- A. **Protect accessories** against damage during remainder of construction period, complying with manufacturer's directions.

END OF SECTION

THIS PAGE LEFT BLANK INTENTIONALLY

DIVISIONS 13 thru 14 – NOT USED

THIS PAGE LEFT BLANK INTENTIONALLY

Intermountain Riverton Hospital – ASC Conversion

3741 W 12600 S | RIVERTON, UTAH

OWNER

Intermountain Healthcare
36 S State Street, 23rd Floor | Salt Lake City, Utah

DATE

01 September 2022

THIS PAGE LEFT BLANK INTENTIONALLY

TABLE OF CONTENTS

DIVISION AND SECTION	TITLE
DIVISION 00	PROCUREMENT AND CONTRACT REQUIREMENTS
Section 00 4000	Bid Form
Section 00 4373	Schedule of Values
Section 00 5200	Owner/Contractor Agreement
Section 00 6000	Bonds and Certificates
Section 00 6276.13	Exemption Certificate
Section 00 7000	General Conditions
Section 00 7301	Access and Confidentiality Agreement
Section 00 7302	Third Party Remote Access Form
	Pre-Construction Work Permit – Above Ceiling
	Pre-Construction Work Permit – Hot work
	Pre-Construction Work Permit – Infection Control Risk Assessment
	Pre-Construction Work Permit – Interim Life Safety Measures Work
Permit	
DIVISION 01	GENERAL REQUIREMENTS
Section 01 1100	Summary of Work
Section 01 1101	Preconstruction Responsibility Matrix
Section 01 1900	Definitions and Standards
Section 01 2600	Contract Modification Procedures
Section 01 2900	Payment Procedures
Section 01 3100	Project Management and Coordination
Section 01 3300	Submittal Procedures
Section 01 5000	Temporary Facilities and Controls
Section 01 6000	Product Requirements
Section 01 7300	Execution
Section 01 7301	Pre-Construction Safety Requirements
Section 01 7329	Cutting and Patching
Section 01 7700	Closeout Procedures
Section 01 7701	Record Drawing Requirements
DIVISION 02	EXISTING CONDITIONS
Section 02 4102	Selective Demolition
DIVISION 03	CONCRETE
Not Used	
DIVISION 04	MASONRY
Not Used	
DIVISION 05	METALS
Section 05 5000	Metal Fabrication

DIVISION 06**WOOD, PLASTICS, AND COMPOSITES**

Section 06 1053 Miscellaneous Rough Carpentry
Section 06 2000 Finish Carpentry
Section 06 4023 Interior Architectural Woodwork

DIVISION 07**THERMAL AND MOISTURE PROTECTION**

Section 07 2116 Blanket Insulation
Section 07 8400 Through-Penetration Firestop Systems
Section 07 8443 Fire-Resistant Firestops and Joint Systems
Section 07 9200 Joint Sealants

DIVISION 08**OPENINGS**

Section 08 1113 Hollow Metal Doors and Frames
Section 08 1416 Flush Wood Doors
Section 08 3100 Access Doors and Frames
Section 08 7100 Door Hardware
Section 08 8000 Glazing
Section 08 8816 Vision Control Glass

DIVISION 09**FINISHES**

Section 09 2216 Non-Structural Metal Framing
Section 09 2900 Gypsum Board
Section 09 3013 Ceramic Tile
Section 09 5100 Acoustical Ceilings
Section 09 6513 Resilient Wall Base and Accessories
Section 09 6516 Resilient Floor Coverings
Section 09 9100 Painting
Section 09 9124 Sherwin Williams Contractor Job Tracking From

DIVISION 10**SPECIALTIES**

Section 10 2123 Cubicle Tracks and Curtains
Section 10 2613 Corner Guards
Section 10 2623.13 Impact Resistant Wall Protection
Section 10 2800 Toilet and Bath Accessories
Section 10 4400 Fire-Protection Specialties

DIVISION 11**EQUIPMENT**

Section 11 7013 Medical Equipment
Section 11 7014 Equipment Schedule

DIVISION 12**FURNISHINGS**

Section 12 9000 Building Accessories

DIVISIONS 13 - 14

Not Used

DIVISION 21

FIRE SUPPRESSION

Section 21 1000

Water-Based Fire-Suppression Systems

DIVISION 22

PLUMBING

Section 22 0500

Common Work Results for Plumbing

Section 22 0513

Common Motor Requirements for Plumbing Equipment

Section 22 0517

Sleeves and Seals for Plumbing Piping

Section 22 0518

Escutcheons for Plumbing Piping

Section 22 0523

General Duty Valves for Plumbing Piping

Section 22 0529

Hangers and Supports for Plumbing Piping and Equipment

Section 22 0548

Vibration and Seismic Control for Plumbing Piping and Equipment

Section 22 0553

Identification for Plumbing Piping and Equipment

Section 22 0719

Plumbing Piping Insulation

Section 22 1116

Domestic Water Piping

Section 22 1119

Domestic Water Piping Specialties

Section 22 1316

Sanitary Waste and Vent Piping

Section 22 1319

Sanitary Waste Piping Specialties

Section 22 6113

Compressed-Air Piping for Laboratory and Healthcare Facilities

Section 22 6213

Vacuum Piping for Laboratory and Healthcare Facilities

Section 22 6314

Medical Gas Piping

DIVISION 23

HEATING, VENTILATION, AND AIR CONDITIONING

Section 23 0100

Mechanical Requirements

Section 23 0150

Temporary Use of Equipment and Systems

Section 23 0500

Common Work Result for HVAC

Section 23 0513

Common Motor Requirements for HVAC Equipment

Section 23 0517

Sleeves and Sleeve Seals for HVAC Piping

Section 23 0518

Escutcheons for HVAC Piping

Section 23 0519

Meters and Gages for HVAC

Section 23 0523

General-Duty Valves for HVAC Piping

Section 23 0529

Hangers and Supports for HVAC Piping and Equipment

Section 23 0548

Vibration and Seismic Controls for HVAC

Section 23 0550

Operation and Maintenance of HVAC Systems

Section 23 0553

Identification for HVAC Piping and Equipment

Section 23 0593

Testing, Adjusting, and Balancing for HVAC

Section 23 0713

Duct Insulation

Section 23 0719

HVAC Piping Insulation

Section 23 0900

Instrumentation and Control for HVAC

Section 23 2113

Hydronic Piping

Section 23 2116

Hydronic Piping Specialties

Section 23 3001

Common Duct Requirements

Section 23 3113

Metal Ducts

Section 23 3300

Air Duct Accessories

Section 23 3423

HVAC Power Ventilators

Section 23 3600

Air Terminal Units

Section 23 3713

Diffusers, Registers, and Grilles

DIVISION 26**ELECTRICAL**

Section 26 0519	Low-Voltage Electrical Power Conductors and Cables
Section 26 0526	Grounding and Bonding for Electrical Systems
Section 26 0529	Hangers and Supports for Electrical Systems
Section 26 0533	Raceways and Boxes for Electrical Systems
Section 26 0548	Vibration and Seismic Controls for Electrical Systems
Section 26 0553	Identification for Electrical Systems
Section 26 0923	Lighting Control Devices
Section 26 2726	Wiring Devices
Section 26 5119	LED Interior Lighting

DIVISION 27**COMMUNICATIONS**

Section 27 0000	General Common Conditions for All Communication Sections
Section 27 0100	Operation and Maintenance of Communications Systems
Section 27 0113	Warranty, Product and System
Section 27 0119	Field Testing and Reporting
Section 27 0133	Shop Drawings, Product Data, Samples Design Records and Existing Conditions
Section 27 0143	Qualifications and Required Training for Contractors and Installers
Section 27 0171	Responsibility and Workmanship of Contractor
Section 27 0500	Common Work Results for Communications
Section 27 0526	Grounding and Bonding for Communications Systems
Section 27 0528	Pathways for Communications Systems
Section 27 0529	Hangers and Supports for Communication Systems
Section 27 0533	Conduits and Back Boxes for Communications Systems
Section 27 0536	Cable Trays for Communications Systems
Section 27 0543	Campus Cable Routing
Section 27 0553	Identification for Low-Voltage Cables and Labeling
Section 27 1100	Equipment Room Fittings
Section 27 1116	Cabinets, Racks, Frames, and Enclosures
Section 27 1119	Termination Blocks and Patch Panels
Section 27 1300	Backbone Cabling
Section 27 1500	Horizontal Cabling
Section 27 1513	Copper Cable
Section 27 1543	Faceplates and Connectors
Section 27 1619	Patch Cables
Section 27 5223	Nurse Call/Code Blue Systems
Section 27 5319	Internal Cellular, Paging and Antenna Systems
Section 27 6001	Appendix 01 – Deviation Request Process
Section 27 6002	Appendix 02 – Document Refresh Process
Section 27 6003	Appendix 03 – Data Center, Tec, TDR Part Numbers
Section 27 6004	Appendix 04 – Reference Standards
Section 27 6005	Appendix 05 – Definitions and Abbreviations
Section 27 6006	Appendix 06 – Material Suppliers
Section 27 6007	Appendix 07 – Siemon Certified Installation Firms
Section 27 6008	Appendix 08 – Lead Wall Penetrations

DIVISION 28**ELECTRONIC SAFETY AND SECURITY**

Section 28 1300	Access Control Section 28 2300 Video Surveillance
Section 28 2300	Video Surveillance
Section 28 3111	Digital, Addressable Fire-Alarm System

DIVISIONS 31 thru 48

Not Used

END OF TABLE OF CONTENTS

THIS PAGE LEFT BLANK INTENTIONALLY

DIVISION 21 – FIRE SUPPRESSION

Section 21 1000

Water-Based Fire-Suppression Systems

THIS PAGE LEFT BLANK INTENTIONALLY

SECTION 21 1000

WATER-BASED FIRE-SUPPRESSION SYSTEMS

PART 1 - GENERAL

1.1 RELATED DOCUMENTS

- A. Drawings and general provisions of the contract, including General and Supplementary Conditions and Division 01 Specification Sections, apply to this Section.

1.2 SUMMARY

- A. This Section includes the following fire-suppression piping inside the building:

1. Wet-pipe sprinkler systems.
2. Description:

- B. Related Sections include the following:

1. Division 10 Section "Fire Extinguisher Cabinets" and "Fire Extinguishers" for cabinets and fire extinguishers.
2. Division 22 Section "Facility Water Distribution Piping" for piping outside the building.
3. Division 28 Section "Fire Detection and Alarm" for alarm devices not specified in this Section.

- C. All black steel sprinkler pipe shall have a wall thickness less than or equal to schedule 40 and greater than schedule 10.

1. Exception: Pipe with a nominal pipe size of 6 inches and greater may be schedule 10.

- D. Summary Table:

Item	Summary
Underground service entrance piping	Existing to remain.
Interior pipe type	Mains: Schedule 40 Branchlines: Threadable thinwall or schedule 40
Sprinkler Finish	Flat Plate Concealed, except uprights and storage
Extended Coverage	Not Allowed
Center of Tile	Required, Center thirds are acceptable for rectangular tiles
Flexible Sprinkler Drops	Match existing.
FM Global	No
Calculations	Not required if the existing hydraulic demand is maintained.
Alarm Device	Horn/Strobe
FDC	Existing remain.
Special Items	
Seismic	

1.3 DEFINITIONS

- A. CPVC: Chlorinated polyvinyl chloride plastic.
- B. CR: Chlorosulfonated polyethylene synthetic rubber.
- C. High-Pressure Piping System: Fire-suppression piping system designed to operate at working pressure higher than standard 175 psig.
- D. PE: Polyethylene plastic.
- E. Underground Service-Entrance Piping: Underground service piping below the building.

1.4 SYSTEM DESCRIPTIONS

- A. Wet-Pipe Sprinkler System: Automatic sprinklers are attached to piping containing water and that is connected to water supply. Water discharges immediately from sprinklers when they are opened. Sprinklers open when heat melts fusible link or destroys frangible device. Hose connections are included if indicated.

1.5 PERFORMANCE REQUIREMENTS

- A. Standard Piping System Component Working Pressure: Listed for at least 175 psig.
- B. High-Pressure Piping System Component Working Pressure: Listed for 250 psig minimum 300 psig.
- C. Fire-suppression standpipe system design shall be approved by authorities having jurisdiction.
 - 1. Minimum residual pressure at each hose-connection outlet is the following:
 - a. NPS 1-1/2 Hose Connections: 65 psig.
 - b. NPS 2-1/2 Hose Connections: 100 psig.
 - 2. Unless otherwise indicated, the following is maximum residual pressure at required flow at each hose-connection outlet:
 - a. NPS 1-1/2 Hose Connections: 100 psig.
 - b. NPS 2-1/2 Hose Connections: 175 psig.
- D. Contractor is responsible for obtaining flow information for hydraulic calculations if the existing hydraulic demand is increased. Design sprinkler piping according to 10% reduced flow data and obtain approval from engineer, prior to submitting to other authorities having jurisdiction:
 - 1. Margin of Safety for Available Water Flow and Pressure: 10 percent, including losses through water-service piping, valves, and backflow preventers.
 - 2. Sprinkler Occupancy Hazard Classifications:
 - a. Automobile Parking Areas: Ordinary Hazard, Group 1.
 - b. Building Service Areas: Ordinary Hazard, Group 1.

- c. Electrical Equipment Rooms: Ordinary Hazard, Group 1.
 - d. General Storage Areas: Ordinary Hazard, Group 1.
 - e. Laundries: Ordinary Hazard, Group 1.
 - f. Libraries, Except Stack Areas: Light Hazard.
 - g. Library Stack Areas: Ordinary Hazard, Group 2.
 - h. Mechanical Equipment Rooms: Ordinary Hazard, Group 1.
 - i. Office and Public Areas: Light Hazard.
 - j. Residential Living Areas: Light Hazard.
 - k. Restaurant Service Areas: Ordinary Hazard, Group 1.
3. Minimum Density for Automatic-Sprinkler Piping Design:
- a. Light-Hazard Occupancy: 0.10 gpm over 1500-sq. ft. area.
 - b. Ordinary-Hazard, Group 1 Occupancy: 0.15 gpm over 1500-sq. ft. area.
 - c. Ordinary-Hazard, Group 2 Occupancy: 0.20 gpm over 1500-sq. ft. area.
 - d. Special Occupancy Hazard: As determined by authorities having jurisdiction.
4. Maximum Protection Area per Sprinkler: Per UL listing.
5. Maximum Protection Area per Sprinkler:
- a. Office Spaces: 225 sq. ft..
 - b. Storage Areas: 130 sq. ft..
 - c. Mechanical Equipment Rooms: 130 sq. ft..
 - d. Electrical Equipment Rooms: 130 sq. ft..
 - e. Other Areas: According to NFPA 13 recommendations, unless otherwise indicated.
6. Total Combined Hose-Stream Demand Requirement: According to NFPA 13, unless otherwise indicated:
- a. Light-Hazard Occupancies: 100 gpm for 30 minutes.
 - b. Ordinary-Hazard Occupancies: 250 gpm for 60 to 90 minutes.
7. Sprinklers are to be installed throughout the premises, as required by NFPA 13.
- E. Seismic Performance: Fire-suppression piping shall be capable of withstanding the effects of earthquake motions determined according to NFPA 13.

1.6 SUBMITTALS

- A. Product Data: For the following:
- 1. Piping materials, including dielectric fittings, flexible connections, and sprinkler specialty fittings.
 - 2. Pipe hangers and supports, including seismic restraints.
 - 3. Valves, including listed fire-protection valves, unlisted general-duty valves, and specialty valves and trim.
 - 4. Air compressors, including electrical data.
 - 5. Sprinklers, escutcheons, and guards. Include sprinkler flow characteristics, mounting, finish, and other pertinent data.
 - 6. Hose connections, including size, type, and finish.
 - 7. Fire department connections, including type; number, size, and arrangement of inlets; caps and chains; size and direction of outlet; escutcheon and marking; and finish.
 - 8. Alarm devices, including electrical data.
- B. Shop Drawings: Diagram power, signal, and control wiring.

- C. Fire-hydrant flow test report.
- D. Seismic Calculations.
- E. Approved Sprinkler Piping Drawings: Working plans, prepared according to NFPA 13, that have been approved by authorities having jurisdiction, including hydraulic calculations, if applicable. Drawings are to be approved by Engineer prior to submission to State Fire Marshal.
- F. Field Test Reports and Certificates: Indicate and interpret test results for compliance with performance requirements and as described in NFPA 13 and NFPA 14. Include "Contractor's Material and Test Certificate for Aboveground Piping" and "Contractor's Material and Test Certificate for Underground Piping."
- G. Welding certificates.
- H. Field quality-control test reports.
- I. Operation and Maintenance Data: For standpipe and sprinkler specialties to include in emergency, operation, and maintenance manuals.

1.7 QUALITY ASSURANCE

A. Installer Qualifications:

1. An experienced installer who has designed and installed fire-suppression piping similar to that indicated for this Project and obtained design approval and inspection approval from authorities having jurisdiction. The Engineer requires evidence to support the ability of the contractor to perform work in the scope and volume as specified. A contractor, who cannot show such experience, may be found not suitable to perform the work. The following are the approved contractors for this project:

a. PRE-APPROVED CONTRACTORS LIST

- 1) A&D Fire
- 2) Alta Fire
- 3) Certified Fire
- 4) Chaparral Fire (A-1 National)
- 5) Delta Fire
- 6) Kimco Fire
- 7) Preferred Fire Protection
- 8) Quality Fire Protection
- 9) FireTrol
- 10) FireFly Fire Protection
- 11) Simplex-Grinnell
- 12) State Fire DC Specialties
- 13) The Safety Team
- 14) Western Automatic
- 15) Or prior approved equal

- b. A contractor not listed in the "PRE-APPROVED CONTRACTORS LIST" must receive prior approval from the engineer to bid this project.

- B. Installer's responsibilities include designing, fabricating, and installing fire-suppression systems and providing professional engineering services needed to assume engineering responsibility. Base calculations on results of fire-hydrant flow test.

1. Engineering Responsibility: Preparation of working plans, calculations, and field test reports by a qualified professional engineer or NICET Level III technician.
- C. Welding: Qualify processes and operators according to ASME Boiler and Pressure Vessel Code: Section IX.
- D. NFPA Standards: Fire-suppression-system equipment, specialties, accessories, installation, and testing shall comply with the following:
 1. NFPA 13, "Installation of Sprinkler Systems."
 2. NFPA 13R, "Installation of Sprinkler Systems in Residential Occupancies up to and Including Four Stories in Height."
 3. NFPA 14, "Installation of Standpipe, Private Hydrant, and Hose Systems."
 4. NFPA 24, "Installation of Private Fire Service Mains and Their Appurtenances."
- E. International Conference of Building Code Officials codes and standards complying with the following:
 1. IBC-2018, "International Building Code."
 2. IFC-2018, "International Fire Code."
- F. Utah Amendments
 1. Title 15A

1.8 COORDINATION

- A. Coordinate layout and installation of sprinklers with other construction that penetrates ceilings, including light fixtures, HVAC equipment, and partition assemblies.

1.9 EXTRA MATERIALS

- A. Furnish extra materials described below that match products installed and that are packaged with protective covering for storage and identified with labels describing contents.
 1. Sprinkler Cabinets: Finished, wall-mounting, steel cabinet with hinged cover, with space for minimum of six spare sprinklers plus sprinkler wrench. Include number of sprinklers required by NFPA 13 and sprinkler wrench. Include a minimum of six spare sprinklers for each type and rating of sprinkler head in the project per CMS and CDC requirement. The minimum number of sprinklers per NFPA 13 shall be required regardless of how many head types there are. There is no upper limit of spare sprinklers. Include separate cabinet with sprinklers and wrench for each type of sprinkler on Project.

1.10 General Engineering Quality

- A. Unless noted otherwise the following applies:
 1. The maximum water velocity shall not exceed 32-fps.
 2. Submit the calculations using the reduced flow data.
 3. When calculating flexible drops, the contractor shall use the maximum number of bends for the associated length. The value is to be taken from the UL tests (unless the material is only FM approved).

4. In the event of multiple (3) submittal rejections (including revise and resubmit) a meeting shall be held at the engineer's office at the engineer time of choosing and the designer, fire sprinkler contractor, and general contractor shall be physically in attendance to discuss the required modifications to the design.

1.11 Contract Completion

- A. Incomplete and Unacceptable work:
 1. If additional site visits or design work is required by the Engineer or Architect because of the use of incomplete or unacceptable work by the Contractor, then the Contractor shall reimburse the Engineer and Architect for all additional time and expenses involved.

PART 2 - PRODUCTS

2.1 MANUFACTURERS

- A. In other Part 2 articles where titles below introduce lists, the following requirements apply to product selection:
 1. Manufacturers: Subject to compliance with requirements, provide products by one of the manufacturers specified.

2.2 DUCTILE-IRON PIPE AND FITTINGS

- A. Mechanical-Joint, Ductile-Iron Pipe: AWWA C151, with mechanical-joint bell end and plain end.
 1. Mechanical-Joint, Ductile-Iron Fittings: AWWA C110, Class 53, ductile- or gray-iron standard pattern or AWWA C153, ductile-iron compact pattern.
 2. Glands, Gaskets, and Bolts: AWWA C111, ductile- or gray-iron gland, rubber gasket, and steel bolts and nuts.
- B. Push-on-Joint, Ductile-Iron Pipe: AWWA C151, with push-on-joint bell end and plain end.
 1. Push-on-Joint, Ductile-Iron Fittings: AWWA C110, ductile- or gray-iron standard pattern or AWWA C153, ductile-iron compact pattern.
 2. Gaskets: AWWA C111, rubber.

2.3 C-900 TUBE AND FITTINGS

- A. PVC, AWWA Pipe: AWWA C900, Class 150, with bell end with gasket and spigot end.
 1. Comply with UL 1285 for fire-service mains if indicated.
 2. PVC Fabricated Fittings: AWWA C900, Class 150, with bell-and-spigot or double-bell ends. Include elastomeric gasket in each bell.
 3. PVC Molded Fittings: AWWA C907, Class 150, with bell-and-spigot or double-bell ends. Include elastomeric gasket in each bell.
 4. Push-on-Joint, Ductile-Iron Fittings: AWWA C110, ductile- or gray-iron standard pattern or AWWA C153, ductile-iron compact pattern.

- a. Gaskets: AWWA C111, rubber.
- 5. Mechanical-Joint, Ductile-Iron Fittings: AWWA C110, ductile- or gray-iron standard pattern or AWWA C153, ductile-iron compact pattern.
 - a. Glands, Gaskets, and Bolts: AWWA C111, ductile- or gray-iron glands, rubber gaskets, and steel bolts.

2.4 STAINLESS STEEL IN BUILDING RISER

- A. Continuous from the factory, no field formed fittings in the stainless steel riser. Field modifications are not allowed. Restrain with thrust block, per NFPA 24, rods as required by manufacture.
 - 1. Inlet: AWWA C900/DIP
 - 2. Outlet: AWWA 606

2.5 STEEL PIPE AND FITTINGS

- A. Threaded-End, Standard-Weight Steel Pipe: ASTM A 53/A 53M, ASTM A 135, or ASTM A 795, hot-dip galvanized where indicated and with factory- or field-formed threaded ends.
 - 1. Cast-Iron Threaded Flanges: ASME B16.1.
 - 2. Malleable-Iron Threaded Fittings: ASME B16.3.
 - 3. Gray-Iron Threaded Fittings: ASME B16.4.
 - 4. Steel Threaded Pipe Nipples: ASTM A 733, made of ASTM A 53/A 53M or ASTM A 106, Schedule 40, seamless steel pipe hot-dip galvanized where indicated. Include ends matching joining method.
 - 5. Steel Threaded Couplings: ASTM A 865 hot-dip galvanized-steel pipe where indicated.
- B. Plain-End, Standard-Weight Steel Pipe: ASTM A 53/A 53M, ASTM A 135, or ASTM A 795 hot-dip galvanized-steel pipe where indicated.
 - 1. Locking-Lug Fittings: UL 213, ductile-iron body with retainer lugs that require one-quarter turn to secure pipe in fitting not allowed.
- C. Plain-End, Standard-Weight Steel Pipe: ASTM A 53/A 53M, ASTM A 135, or ASTM A 795 hot-dip galvanized-steel pipe where indicated.
 - 1. Steel Welding Fittings: ASTM A 234/A 234M, and ASME B16.9 or ASME B16.11.
 - 2. Steel Flanges and Flanged Fittings: ASME B16.5.
- D. Grooved-End, Standard-Weight Steel Pipe: ASTM A 53/A 53M, ASTM A 135, or ASTM A 795, hot-dip galvanized where indicated and with factory- or field-formed, roll-grooved ends.
 - 1. Grooved-Joint Piping Systems:
 - a. Manufacturers:
 - 1) Anvil International, Inc.
 - 2) Bull Moose Tube, Inc

- 3) Central Sprinkler Corp.
 - 4) Victaulic Co. of America.
 - 5) Ward Manufacturing.
 - 6) Wheatland Tube
- b. Grooved-End Fittings: UL-listed, ASTM A 536, ductile-iron casting with OD matching steel-pipe OD.
 - c. Grooved-End-Pipe Couplings: UL 213 and AWWA C606, rigid pattern, unless otherwise indicated; gasketed fitting matching steel-pipe OD. Include ductile-iron housing with keys matching steel-pipe and fitting grooves, prelubricated rubber gasket listed for use with housing, and steel bolts and nuts.
- E. Threaded-End, Threadable, Thinwall Steel Pipe: ASTM A 135 or ASTM A 795, with wall thickness less than Schedule 40 and greater than Schedule 10, and with factory- or field-formed threaded ends.
1. Cast-Iron Threaded Flanges: ASME B16.1.
 2. Malleable-Iron Threaded Fittings: ASME B16.3.
 3. Gray-Iron Threaded Fittings: ASME B16.4.
 4. Steel Threaded Pipe Nipples: ASTM A 733, made of ASTM A 53/A 53M or ASTM A 106, Schedule 40, seamless steel pipe.
 5. Steel Threaded Couplings: ASTM A 865.
- F. Plain-End, Threadable, Thinwall Steel Pipe: ASTM A 135 or ASTM A 795, with wall thickness less than Schedule 40 and greater than Schedule 10.
1. Locking-Lug Fittings: UL 213, ductile-iron body with retainer lugs that require one-quarter turn to secure pipe in fitting not allowed.
- G. Plain-End, Threadable, Thinwall Steel Pipe: ASTM A 135 or ASTM A 795, with wall thickness less than Schedule 40 and greater than Schedule 10.
1. Steel Welding Fittings: ASTM A 234/A 234M, and ASME B16.9 or ASME B16.11.
 2. Steel Flanges and Flanged Fittings: ASME B16.5.
- H. Grooved-End, Threadable, Thinwall Steel Pipe: ASTM A 135 or ASTM A 795, with wall thickness less than Schedule 40 and greater than Schedule 10, and with factory- or field-formed, roll-grooved ends.
1. Grooved-Joint Piping Systems:
 - a. Manufacturers:
 - 1) Anvil International, Inc.
 - 2) Bull Moose Tube, Inc
 - 3) Central Sprinkler Corp.
 - 4) Victaulic Co. of America.
 - 5) Ward Manufacturing.
 - 6) Wheatland Tube
 - b. Grooved-End Fittings: UL-listed, ASTM A 536, ductile-iron casting with OD matching steel-pipe OD.
 - c. Grooved-End-Pipe Couplings: UL 213 and AWWA C606, rigid pattern, unless otherwise indicated; gasketed fitting matching steel-pipe OD. Include ductile-iron

housing with keys matching steel-pipe and fitting grooves, prelubricated rubber gasket listed for use with housing, and steel bolts and nuts.

- I. Plain-End, Schedule 10 Steel Pipe: ASTM A 135 or ASTM A 795, Schedule 10 is not allowed.
- J. Plain-End, Nonstandard OD, Thinwall Steel Pipe: ASTM A 135 or ASTM A 795, with wall thickness less than Schedule 10 is not allowed.
- K. Plain-End, Hybrid Steel Pipe: ASTM A 135 or ASTM A 795, lightwall, with wall thickness less than Schedule 10 and greater than Schedule 5 is not allowed.
- L. Grooved-End, Hybrid Steel Pipe: ASTM A 135 or ASTM A 795, lightwall, with wall thickness less than Schedule 10 and greater than Schedule 5; with factory- or field-formed, roll-grooved ends are not allowed.
- M. Schedule 5 Steel Pipe: ASTM A 135 or ASTM A 795, lightwall, with plain ends is not allowed.

2.6 CPVC TUBE AND FITTINGS

- A. CPVC is not allowed on this project.

2.7 FLEXIBLE SPRINKLER DROPS

- A. Flexible connectors shall be FM approved with exterior wire braid and have materials suitable for system fluid. Include 175-psig minimum working-pressure rating and ends according to the following:
 - 1. NPS 1: Threaded.
- B. Manufacturers:
 - 1. Flex-Head
 - 2. Victaulic
- C. Stainless-Steel-Hose/Steel Pipe, Flexible Connectors: Corrugated, stainless-steel, inner tubing covered with stainless-steel wire braid. Include steel nipples or flanges, welded to hose.
- D. Stainless-Steel-Hose/Stainless-Steel Pipe, Flexible Connectors: Corrugated, stainless-steel, inner tubing covered with stainless-steel wire braid. Include stainless-steel nipples or flanges, welded to hose.

2.8 FLEXIBLE PIPE CONNECTORS (SEISMIC)

- A. Flexible connectors shall be FM approved with exterior wire braid and have materials suitable for system fluid. Include 175-psig minimum working-pressure rating and ends according to the following:
 - 1. NPS 2 and Smaller: Threaded.
 - 2. NPS 2-1/2 and Larger: Flanged.
 - 3. Option for NPS 2-1/2 and Larger: Grooved for use with grooved-end-pipe couplings.

B. Manufacturers:

1. Flexicraft Industries.
2. Flex-Pression, Ltd.
3. Metraflex, Inc.

C. Bronze-Hose, Flexible Connectors: Corrugated, bronze, inner tubing covered with bronze wire braid. Include copper-tube ends or bronze flanged ends, braze welded to hose.

D. Stainless-Steel-Hose/Steel Pipe, Flexible Connectors: Corrugated, stainless-steel, inner tubing covered with stainless-steel wire braid. Include steel nipples or flanges, welded to hose.

E. Stainless-Steel-Hose/Stainless-Steel Pipe, Flexible Connectors: Corrugated, stainless-steel, inner tubing covered with stainless-steel wire braid. Include stainless-steel nipples or flanges, welded to hose.

2.9 CORROSION-PROTECTIVE ENCASEMENT FOR PIPING

- A. Encasement for Underground Metal Piping: ASTM A 674 or AWWA C105, PE film, 0.008-inch minimum thickness, tube or sheet.

2.10 SPRINKLER SPECIALTY FITTINGS

A. Sprinkler specialty fittings shall be FMG approved with 175-psig minimum working-pressure rating, and made of materials compatible with piping. Sprinkler specialty fittings shall have 250-psig minimum working-pressure rating if fittings are components of high-pressure piping systems.

B. Sprinkler Drain and Alarm Test Fittings: Cast- or ductile-iron body, with threaded or locking-lug inlet and outlet, test valve, and orifice and sight glass.

1. Manufactures:

- a. Central Sprinkler Corp.
- b. Fire-End and Croker Corp.
- c. Viking Corp.
- d. Victaulic Co. of America.

C. Sprinkler Branch-Line Test Fittings: Brass body with threaded inlet, capped drain outlet, and threaded outlet for sprinkler.

D. Sprinkler Inspector's Test Fitting: Cast- or ductile-iron housing with threaded inlet and drain outlet and sight glass.

E. Drop-Nipple Fittings: UL 1474, adjustable with threaded inlet and outlet, and seals.

F. Dry-Pipe-System Fittings: UL listed for dry-pipe service.

2.11 LISTED FIRE-PROTECTION VALVES

- A. Valves shall be FMG approved, with 175-psig minimum pressure rating. Valves shall have 250-psig minimum pressure rating if valves are components of high-pressure piping system.
- B. Gate Valves with Wall Indicator Posts:
1. Gate Valves: UL 262, cast-iron body, bronze mounted, with solid disc, nonrising stem, operating nut, and flanged ends.
 2. Indicator Posts: UL 789, horizontal-wall type, cast-iron body, with hand wheel, extension rod, locking device, and cast-iron barrel.
 3. Manufacturers:
 - a. Grinnell Fire Protection.
 - b. McWane, Inc.; Kennedy Valve Div.
 - c. NIBCO.
 - d. Stockham.
- C. Ball Valves: Comply with UL 1091, except with ball instead of disc.
1. NPS 1-1/2 and Smaller: Bronze body with threaded ends.
 2. NPS 2 and NPS 2-1/2: Bronze body with threaded ends or ductile-iron body with grooved ends.
 3. NPS 3: Ductile-iron body with grooved ends.
 4. Manufacturers:
 - a. NIBCO.
 - b. Victaulic Co. of America.
- D. Butterfly Valves: UL 1091.
1. NPS 2 and Smaller: Bronze body with threaded ends.
 - a. Manufacturers:
 - 1) Global Safety Products, Inc.
 - 2) Milwaukee Valve Company.
 2. NPS 2-1/2 and Larger: Bronze, cast-iron, or ductile-iron body; wafer type or with flanged or grooved ends.
 - a. Manufacturers:
 - 1) Central Sprinkler Corp.
 - 2) McWane, Inc.; Kennedy Valve Div.
 - 3) Mueller Company.
 - 4) NIBCO.
 - 5) Victaulic Co. of America.
- E. Check Valves NPS 2 and Larger: UL 312, swing type, cast-iron body with flanged or grooved ends.
1. Manufacturers:
 - a. American Cast Iron Pipe Co.; Waterous Co.

- b. Central Sprinkler Corp.
- c. Clow Valve Co.
- d. Crane Co.; Crane Valve Group; Crane Valves.
- e. Crane Co.; Crane Valve Group; Jenkins Valves.
- f. Fivalco
- g. Globe Fire Sprinkler Corporation.
- h. Grinnell Fire Protection.
- i. Hammond Valve.
- j. McWane, Inc.; Kennedy Valve Div.
- k. Mueller Company.
- l. NIBCO.
- m. Potter-Roemer; Fire Protection Div.
- n. Reliable Automatic Sprinkler Co., Inc.
- o. Star Sprinkler Inc.
- p. Stockham.
- q. United Brass Works, Inc.
- r. Victaulic Co. of America.
- s. Watts Industries, Inc.; Water Products Div.

F. Gate Valves: UL 262, OS&Y type.

- 1. NPS 2 and Smaller: Bronze body with threaded ends.

- a. Manufacturers:

- 1) Crane Co.; Crane Valve Group; Crane Valves.
- 2) Fivalco.
- 3) Hammond Valve.
- 4) NIBCO.
- 5) United Brass Works, Inc.

- 2. NPS 2-1/2 and Larger: Cast-iron body with flanged ends.

- a. Manufacturers:

- 1) Clow Valve Co.
- 2) Crane Co.; Crane Valve Group; Crane Valves.
- 3) Crane Co.; Crane Valve Group; Jenkins Valves.
- 4) Fivalco
- 5) Hammond Valve.
- 6) Milwaukee Valve Company.
- 7) Mueller Company.
- 8) NIBCO.
- 9) United Brass Works, Inc.

G. Indicating Valves: UL 1091, with integral indicating device and ends matching connecting piping.

- 1. Indicator: Electrical, 115-V ac, prewired, single-circuit, supervisory switch and Visual.
- 2. NPS 2 and Smaller: Ball or butterfly valve with bronze body and threaded ends.

- a. Manufacturers:

- 1) Milwaukee Valve Company.
- 2) NIBCO.

- 3) Victaulic Co. of America.
3. NPS 2-1/2 and Larger: Butterfly valve with cast- or ductile-iron body; wafer type or with flanged or grooved ends.
 - a. Manufacturers:
 - 1) Central Sprinkler Corp.
 - 2) Grinnell Fire Protection.
 - 3) McWane, Inc.; Kennedy Valve Div.
 - 4) Milwaukee Valve Company.
 - 5) NIBCO.
 - 6) Victaulic Co. of America.

H. Supervised Normally Closed Valve

1. Indicator: Electrical, 115-V ac, prewired, single-circuit, supervisory switch and visual to send signal on partial close.
 - a. Manufactures:
 - 1) NIBCO.
 - 2) Victaulic Co. of America.

2.12 UNLISTED GENERAL-DUTY VALVES

- A. Ball Valves NPS 2 and Smaller: MSS SP-110, 2-piece copper-alloy body with chrome-plated brass ball, 600-psig minimum CWP rating, blowout-proof stem, and threaded ends.
- B. Check Valves NPS 2 and Smaller: MSS SP-80, Type 4, Class 125 minimum, swing type with bronze body, nonmetallic disc, and threaded ends.
- C. Gate Valves NPS 2 and Smaller: MSS SP-80, Type 2, Class 125 minimum, with bronze body, solid wedge, and threaded ends.
- D. Globe Valves NPS 2 and Smaller: MSS SP-80, Type 2, Class 125 minimum, with bronze body, nonmetallic disc, and threaded ends.

2.13 SPECIALTY VALVES

- A. Sprinkler System Control Valves: FMG approved, cast- or ductile-iron body with flanged or grooved ends, and 175-psig minimum pressure rating. Control valves shall have 250-psig minimum pressure rating if valves are components of high-pressure piping system.
 1. Manufacturers:
 - a. Globe Fire Sprinkler Corporation.
 - b. Reliable Automatic Sprinkler Co., Inc.
 - c. Victaulic Co. of America.
 - d. Viking Corp.
- B. Automatic Drain Valves: UL 1726, NPS 3/4, ball-check device with threaded ends.

1. Manufacturers:
 - a. Grinnell Fire Protection.

2.14 SPRINKLERS

- A. Sprinklers shall be UL listed or FMG approved, with 175-psig minimum pressure rating. Sprinklers shall have 250-psig minimum 300-psig pressure rating if sprinklers are components of high-pressure piping system.
- B. Sprinklers shall have 250-psig minimum 300-psig pressure rating if sprinklers are components of high-pressure piping system.
- C. Manufacturers:
 1. Globe Fire Sprinkler Corporation.
 2. Reliable Automatic Sprinkler Co., Inc.
 3. Victaulic Co. of America.
 4. Viking Corp.
 5. Tyco Fire
- D. Automatic Sprinklers: With heat-responsive element complying with the following:
 1. UL 199, for nonresidential applications.
 2. UL 1626, for residential applications.
- E. Sprinkler Types and Categories: Nominal 1/2-inch orifice for "Ordinary" temperature classification rating, unless otherwise indicated or required by application.
 1. Open Sprinklers: UL 199, without heat-responsive element.
 - a. Orifice: 1/2 inch, with discharge coefficient K between 5.3 and 5.8.
 - b. Orifice: 17/32 inch, with discharge coefficient K between 7.4 and 8.2.
- F. Sprinkler types, features, and options as follows:
 1. Concealed ceiling sprinklers, including cover plate.
 2. Extended-coverage sprinklers, not allowed unless approved in writing prior to bidding.
 3. Flow-control sprinklers, with automatic open and shutoff feature.
 4. Flush ceiling sprinklers, including escutcheon, not allowed.
 5. Institution sprinklers, made with a small, breakaway projection.
 6. Pendent sprinklers.
 7. Pendent, dry-type sprinklers.
 8. Quick-response sprinklers.
 9. Sidewall sprinklers.
 10. Sidewall, dry-type sprinklers.
 11. Upright sprinklers.
- G. Sprinkler Finishes: Chrome plated, bronze, and painted. Finishes as approved by FM Global.
- H. Special Coatings: Wax, lead, and corrosion-resistant paint.

- I. Sprinkler Escutcheons: Materials, types, and finishes for the following sprinkler mounting applications. Escutcheons for concealed, flush, and recessed-type sprinklers are specified with sprinklers.
 - 1. Ceiling Mounting: Flat plate concealed, white.
 - 2. Sidewall Mounting: Flat plate concealed, white.
- J. Sprinkler Guards: Wire-cage type, including fastening device for attaching to sprinkler.

2.15 HOSE CONNECTIONS

A. Manufacturers:

- 1. Central Sprinkler Corp.
- 2. Elkhart Brass Mfg. Co., Inc.
- 3. Fire-End and Croker Corp.
- 4. Fivalco
- 5. Grinnell Fire Protection.
- 6. Guardian Fire Equipment Incorporated.
- 7. McWane, Inc.; Kennedy Valve Div.
- 8. Mueller Company.
- 9. Potter-Roemer; Fire-Protection Div.
- 10. United Brass Works, Inc.

- B. Description: UL 668, brass or bronze, 300-psig minimum pressure rating, hose valve for connecting fire hose. Include angle or gate pattern design; female NPS inlet and male hose outlet; and lugged cap, gasket, and chain. Include NPS 1-1/2 or NPS 2-1/2, and hose valve threads according to NFPA 1963 and matching local fire department threads.

- 1. Valve Operation: Nonadjustable type, unless pressure-regulating type is indicated.
- 2. Finish: Rough metal.

2.16 FIRE DEPARTMENT CONNECTIONS

- A. Existing to remain.

2.17 ALARM DEVICES

- A. Alarm-device types shall match piping and equipment connections.

- B. Electrically Operated Alarm: UL 464, with 8-inch- minimum- diameter, vibrating-type, metal alarm bell with red-enamel factory finish and suitable for outdoor use.

- 1. Manufacturers:

- a. Potter Electric Signal Company.
- b. System Sensor.

- C. Electrically Operated Alarm: Horn/Strobe, NEMA 3R minimum suitable for outdoor use.

- 1. Manufacturers:

- a. Potter Electric Signal Company.
 - b. System Sensor.
- D. Water-Flow Indicator: UL 346, electrical-supervision, paddle-operated-type, water-flow detector with 250-psig pressure rating and designed for horizontal or vertical installation. Include two single-pole, double-throw circuit switches for isolated alarm and auxiliary contacts, 7 A, 125-V ac and 0.25 A, 24-V dc; complete with factory-set, field-adjustable retard element to prevent false signals and tamperproof cover that sends signal if removed.
- 1. Manufacturers:
 - a. ADT Security Services, Inc.
 - b. Grinnell Fire Protection.
 - c. ITT McDonnell & Miller.
 - d. Potter Electric Signal Company.
 - e. System Sensor.
 - f. Viking Corp.
 - g. Watts Industries, Inc.; Water Products Div.
- E. Pressure Switch: UL 753, electrical-supervision-type, water-flow switch with retard feature. Include single-pole, double-throw, normally closed contacts and design that operates on rising pressure and signals water flow.
- 1. Manufacturers:
 - a. Grinnell Fire Protection.
 - b. Potter Electric Signal Company.
 - c. System Sensor.
 - d. Viking Corp.
- F. Valve Supervisory Switch: UL 753, electrical, single-pole, double-throw switch with normally closed contacts. Include design that signals controlled valve is in other than fully open position.
- 1. Manufacturers:
 - a. McWane, Inc.; Kennedy Valve Div.
 - b. Potter Electric Signal Company.
 - c. System Sensor.
- G. Indicator-Post Supervisory Switch: UL 753, electrical, single-pole, double-throw switch with normally closed contacts. Include design that signals controlled indicator-post valve is in other than fully open position.
- 1. Manufacturers:
 - a. Potter Electric Signal Company.
 - b. System Sensor.

2.18 PRESSURE GAGES

A. Manufacturers:

- 1. Brecco Corporation.

2. Dresser Equipment Group; Instrument Div.
 3. Marsh Bellofram.
 4. WIKA Instrument Corporation.
- B. Description: UL 393, 3-1/2- to 4-1/2-inch- diameter, dial pressure gage with range of 0 to 250 psig minimum.
1. Water System Piping: Include caption "WATER" or "AIR/WATER" on dial face.
 2. Air System Piping: Include retard feature and caption "AIR" or "AIR/WATER" on dial face.

2.19 DOUBLE CHECK VALVE ASSEMBLIES

A. Manufacturers

1. Ames
2. Backflow Direct
3. Febco
4. Wilkins
5. Watts

- B. Description; Resilient seated, spring loaded with testable outlets provided, as required by Authorities Having Jurisdiction.

PART 3 - EXECUTION

3.1 PREPARATION

- A. Contractor is responsible for obtaining flow data for hydraulic calculations if the existing hydraulic demand is increased.

3.2 EARTHWORK

- A. Refer to Division 31 Section "Earth Moving" for excavating, trenching, and backfilling.

3.3 EXAMINATION

- A. Examine roughing-in for hose connections and stations to verify actual locations of piping connections before installation.
- B. Examine walls and partitions for suitable thicknesses, fire- and smoke-rated construction, framing for hose-station cabinets, and other conditions where hose connections and stations are to be installed.
- C. Proceed with installation only after unsatisfactory conditions have been corrected.

3.4 PIPING APPLICATIONS

- A. Shop weld pipe joints where welded piping is indicated.

- B. Do not use welded joints for galvanized-steel pipe.
- C. Flanges, flanged fittings, unions, nipples, and transition and special fittings with finish and pressure ratings same as or higher than system's pressure rating may be used in aboveground applications, unless otherwise indicated.
- D. Piping between Fire Department Connections and Check Valves: Galvanized, standard-weight steel pipe with grooved ends; grooved-end fittings; grooved-end-pipe couplings; and grooved joints.
- E. Underground Service-Entrance Piping: Ductile-iron, push-on or mechanical-joint pipe and fittings and restrained joints. Include corrosion-protective encasement.
- F. Sprinkler Main Piping: Use the following:
 - 1. NPS 6 and Smaller: Standard-weight steel pipe with threaded ends, or grooved ends. No plain ends allowed.
 - 2. Outlets shall be welded.
 - a. Victaulic Brand Mechanical tee fittings may be used in lieu of welded outlets.
- G. Branch line piping: Use the following:
 - 1. NPS 1-1/4 and Smaller: Threadable steel pipe with threaded ends; cast- or malleable-iron threaded fittings; and threaded joints.
 - a. Victaulic Brand Mechanical tee fittings may be used
- H. Standpipes and mains: Use the following:
 - 1. NPS 4 to NPS 6: Schedule 40 steel pipe with grooved ends & Welded outlets.
 - 2. NPS 3 and Smaller: Schedule 40 steel pipe with threaded ends, or grooved ends. No plain ends allowed.

3.5 VALVE APPLICATIONS

- A. Drawings indicate valve types to be used. Where specific valve types are not indicated, the following requirements apply:
 - 1. Fire-Protection-Service Valves: UL listed and FM approved for applications where required by NFPA 13 and NFPA 14.
 - 2. General-Duty Valves: For applications where UL-listed and FM-approved valves are not required by NFPA 13 and NFPA 14.
 - a. Shutoff Duty: Use gate, ball, or butterfly valves.
 - b. Throttling Duty: Use globe, ball, or butterfly valves.

3.6 JOINT CONSTRUCTION

- A. Refer to Division 23 Section "Common Work Result for HVAC" for basic piping joint construction.

- B. Ductile-Iron-Piping, Grooved Joints: Use ductile-iron pipe with radius-cut-grooved ends; ductile-iron, grooved-end fittings; and ductile-iron, keyed couplings. Assemble joints with couplings, gaskets, lubricant, and bolts according to coupling manufacturer's written instructions.
- C. Steel-Piping, Grooved Joints: Use Schedule 40 steel pipe with cut or roll-grooved ends and Schedule 30 or thinner steel pipe with roll-grooved ends; steel, grooved-end fittings; and steel, keyed couplings. Assemble joints with couplings, gaskets, lubricant, and bolts according to coupling manufacturer's written instructions. Use gaskets listed for dry-pipe service for dry piping.

3.7 WATER-SUPPLY CONNECTION

- A. Install shutoff Backflow preventions assemblies, valve, pressure gage's, drain, and other accessories at connection to water service.

3.8 PIPING INSTALLATION

- A. Refer to Division 23 Section "Common Work Result for HVAC" for basic piping installation.
- B. Locations and Arrangements: Drawing plans, schematics, and diagrams indicate general location and arrangement of piping. Install piping as indicated, as far as practical.
 - 1. Deviations from approved working plans for piping require written approval from authorities having jurisdiction. File written approval with Architect before deviating from approved working plans.
- C. Install underground service-entrance piping according to NFPA 24 and with restrained joints.
- D. Make connections between underground and above-ground piping using bolted flange.
- E. Install mechanical sleeve seal at pipe penetrations in basement and foundation walls. Refer to Division 23 Section "Common Work Result for HVAC."
- F. Use approved fittings to make changes in direction, branch takeoffs from mains, and reductions in pipe sizes.
- G. Install unions adjacent to each valve in pipes NPS 2 and smaller. Unions are not required on flanged devices or in piping installations using grooved joints.
- H. Install flanges or flange adapters on valves, apparatus, and equipment having NPS 2-1/2 and larger connections.
- I. Install "Inspector's Test Connections" in sprinkler piping, complete with shutoff valve, sized and located according to NFPA 13.
- J. Install sprinkler piping with drains for complete system drainage.
- K. Install sprinkler zone control valves, check valves, test assemblies, and drain risers adjacent to standpipes when sprinkler piping is connected to standpipes.
- L. Install drain valves on standpipes.

- M. Install ball drip valves to drain piping between fire department connections and check valves. Drain to floor drain or outside building.
- N. Install alarm devices in piping systems.
- O. Hangers and Supports: Comply with NFPA 13 for hanger materials. Install according to NFPA 13 for sprinkler piping and to NFPA 14 for standpipes.
 - 1. No powder driven studs allowed.
 - 2. Wrap-around braces are to be provided at end of branch lines.
- P. Earthquake Protection: Install piping according to NFPA 13-9.3 requirements, to protect from earthquake damage. Seismic Bracing shall be designed to withstand vertical forces and movement.
- Q. Install piping with grooved joints according to manufacturer's written instructions. Construct rigid piping joints, unless otherwise indicated, or required by NFPA 13 for flexibility in seismic zones.
- R. Install pressure gages on riser or feed main, at each sprinkler test connection, and at top of each standpipe. Include pressure gages with connection not less than NPS 1/4 and with soft metal seated globe valve, arranged for draining pipe between gage and valve. Install gages to permit removal, and install where they will not be subject to freezing.
- S. When a fire pipe crosses a seismic expansion joint it shall have a Metraflex fire loop installed at the joint in accordance with NFPA 13 chapter 9.

3.9 SPECIALTY SPRINKLER FITTING INSTALLATION

- A. Install specialty sprinkler fittings according to manufacturer's written instructions.

3.10 VALVE INSTALLATION

- A. Refer to Division 23 Section "Valves" for installing general-duty valves. Install fire-protection specialty valves, trim, fittings, controls, and specialties according to NFPA 13 and NFPA 14, manufacturer's written instructions, and authorities having jurisdiction.
- B. Valves: Install fire-protection-service valves supervised-open, located to control sources of water supply except from fire department connections. Provide permanent identification signs indicating portion of system controlled by each valve.
- C. Double Check Valve Assemblies: Install valves in vertical up or horizontal position, per listings and for proper direction of flow.
- D. Deluge Valves: Install in vertical position, in proper direction flow, in main supply to deluge system.

3.11 SPRINKLER APPLICATIONS

- A. General: All sprinklers are to be quick response type. Sprinkler heads shall be of the latest design closed spray type for 155°F unless specified otherwise or required by code. Extended

coverage heads shall not be used. Orifices larger than 1/2" may be used as required by density and spacing demands. Use sprinklers according to the following applications:

1. Rooms without Ceilings: Upright and/or pendent sprinklers. Provide mechanical guards on all heads at or below 7'-0" height above the floor or where damage from room occupant use may occur.
2. Rooms with Ceilings: Concealed sprinklers unless indicated otherwise.
3. Wall Mounting: Concealed sidewall sprinklers unless indicated otherwise.
4. Institutional sprinklers shall be installed in areas of detention, correctional or mental health care facilities.
5. Spaces Subject to Freezing: Upright; pendent, dry-type; and sidewall, dry-type sprinklers.
6. Provide freeze proof type automatic sprinkler heads serving unconditioned spaces, areas subject to freezing and in other areas requiring their use.
7. Heads located within the air streams of unit heaters or other heat-emitting equipment shall be selected for proper temperature rating.
8. Sprinkler Finishes: Use sprinklers with the following finishes:
 - a. Upright, Pendent, and Sidewall Sprinklers: Chrome in finished spaces exposed to view; rough bronze in unfinished spaces not exposed to view.
 - b. Concealed Sprinklers: Rough brass, with White cover plate to match ceiling color.
 - c. Semi-Recessed Sprinklers: White, with FMG approved white escutcheon.

B. Sprinklers: Use the following:

1. All sprinklers shall be listed, quick response type.
2. Sprinkler in future finish spaces (shelled) 10' x 10' spacing shall be pendants/uprights installed with 1 x 1/2" bushing, to accommodate future finishes.
3. Finish ceiling spaces shall have flat-plate concealed sprinklers.

3.12 SPRINKLER INSTALLATION

- A. Every effort shall be required to ensure that the heads form a symmetrical pattern in the ceiling with the ceiling grid if included, as well as lights, diffusers and grilles. Offsets shall be made in piping to accommodate ductwork in the ceiling. Heads shall be symmetrical in all ceilings and all piping run parallel or perpendicular to building lines. Heads shall be linearly aligned in corridors.
1. In no case shall sprinkler heads be installed closer than approved distances from ceiling obstructions and HVAC ductwork.
 2. Sprinkler heads shall not conflict with tile grids.
 3. Sprinkler heads shall be located near center of corridors.
- B. Where layout of sprinkler heads is shown on reflected ceiling plans the locations shall be followed unless approval is obtained from the Architect or such locations shown do not meet the requirements of NFPA-13. In either case, approval of the Architect shall be obtained in writing before sprinkler head locations are changed. If the installation of additional heads is needed to conform to NFPA 13 requirements in areas where heads are shown on reflected ceiling plans, they shall be included in the contract price.
- C. Install sprinklers in patterns indicated.
- D. Do not install pendent or sidewall, wet-type sprinklers in areas subject to freezing. Use dry-type sprinklers with water supply from heated space.

- E. Future finish shelled and tenant finish; Shell spaces shall be piped to accommodate future. Install sprinklers with 1" x ½" bushings, and space heads at a maximum spacing of 100 sq. ft. per head. Occupancy shall be Ordinary-Hazard Group 1 Design.
- F. Concealed type sprinkler shall be installed in the following areas:
 - 1. All areas.

3.13 HOSE-CONNECTION INSTALLATION

- A. Install hose connections adjacent to standpipes, unless otherwise indicated.
- B. Install freestanding hose connections for access and minimum passage restriction.
- C. Install NPS 2-1/2 hose connections with quick-disconnect NPS 2-1/2 by NPS 1-1/2 reducer adapter, cap and chain.

3.14 FIRE DEPARTMENT CONNECTION INSTALLATION

- A. When installing the Fire Department Connection, the contractor is to ensure that there are no permanent obstruction(s) as to the fire department access. If an obstruction is present immediately notify the designer and the design team before proceeding with the installation.
- B. Coordinate the exact location with the Architect and the Authority Having Jurisdiction.
- C. Install ball drip valves at each check valve for fire department connection. Drain to floor drain or outside building.

3.15 CONNECTIONS

- A. Connect water-supply piping and standpipes and sprinklers where indicated.
- B. Connect piping to specialty valves, hose valves, specialties, fire department connections, and accessories.
- C. Electrical Connections: Power wiring is specified in Division 28.
- D. Connect alarm devices to fire alarm.

3.16 LABELING AND IDENTIFICATION

- A. Install labeling and pipe markers on equipment and piping according to requirements in NFPA 13 and NFPA 14 and in Division 23 Section "Common Work Result for HVAC."

3.17 FIELD QUALITY CONTROL

- A. Flush, test, and inspect sprinkler piping according to NFPA 13, "System Acceptance" Chapter.
- B. Flush, test, and inspect standpipes according to NFPA 14, "Tests and Inspection" Chapter.

- C. Replace piping system components that do not pass test procedures and retest to demonstrate compliance. Repeat procedure until satisfactory results are obtained.
- D. When making a mechanical tee connection the coupon shall be attached at the mechanical tee.
- E. Report test results promptly and in writing to Architect and authorities having jurisdiction.
- F. Whether the underground serving the sprinkler system is done by this contractor or another, this contractor will be responsible to assure and have in his possession a certificate that the underground has been flushed and tested by the contractor who installed it in accordance with NFPA-24 prior to connection of the underground piping to the overhead sprinkler system.

3.18 CLEANING

- A. Clean dirt and debris from sprinklers.
- B. Remove and replace sprinklers having paint other than factory finish.

3.19 PROTECTION

- A. Protect sprinklers from damage until Substantial Completion.

3.20 COMMISSIONING

- A. Verify that specialty valves, trim, fittings, controls, and accessories are installed and operate correctly.
- B. Verify that specified tests of piping are complete and that "Material Test Certificates" are complete.
- C. Verify that damaged sprinklers and sprinklers with paint or coating not specified are replaced with new, correct type.
- D. Verify that sprinklers are correct types, have correct finishes and temperature ratings, and have guards as required for each application.
- E. Verify that hose connections and fire department connections have threads compatible with local fire department equipment.
- F. Fill wet-pipe sprinkler piping with water.
- G. Fill standpipes with water.
- H. Verify that hose connections are correct type and size.
- I. Coordinate with fire alarm tests. Operate as required.

3.21 DEMONSTRATION & TESTS

- A. Demonstrate equipment, specialties, and accessories. Review operating and maintenance information.
- B. All tests will be conducted as required by the local authority having jurisdiction, and in no case less than those required by NFPA standards. As a minimum, piping in the sprinkler system shall be tested at a water pressure at 200 psi for a period of not less two hours, or at 50 psi in excess of the normal pressure when the normal pressure is above 150 psi. Bracing shall be in place, and air shall be removed from the system through the hydrants and drain valves before the test pressure is applied. No apparent leaks will be permitted on interior or underground piping.
- C. The local jurisdiction having authority and the Utah State Fire Marshal's office (where required) shall be notified at least three working days in advance of all tests and flushing. This includes any flushing of underground, hydrostatic testing, or flow testing that may be required.
- D. This contractor shall make all the required tests to the sprinkler system as required by code. He shall be responsible to assure that the Contractor Test Certificates for the overhead, backflow and underground work are completed and delivered to the owner's insurance underwriter to assure proper insurance credit.
- E. All tests requiring the witnessing by local authorities will be the responsibility of this contractor. If tests are not run or do not have the proper witness, then they will be run later and all damage caused by the system, or caused in uncovering the system for such test, will be borne by this contractor.

3.22 WARRANTY

- A. This contractor shall warranty the sprinkler system and all its components for one year from the date of acceptance by the owner. Any costs incurred to extend any warranties of materials to assure this time frame shall be borne by this contractor.
- B. Provide Operation and Maintenance Manuals with correct as-builts test certificates and warranties included. A minimum 6 sets to be provided in red 3-ring binders. Include a current adopted version of NFPA 25 softbound copy left with owner.
- C. Electronic copy of AutoCAD as-built drawings shall also be provided on CD, with each O&M Manual.

3.23 FIELD QUALITY CONTROL

- A. Flush, test and inspect sprinkler piping according to NFPA 13, "System Acceptance" Chapter.
- B. Replace piping system components that do not pass test procedures and retest to demonstrate compliance. Repeat procedure until satisfactory results are obtained.
- C. Report test results promptly and in writing to Architect and authorities having jurisdiction.

END OF SECTION 21 1000

DIVISION 22 – PLUMBING

Section 22 0500	Common Work Results for Plumbing
Section 22 0513	Common Motor Requirements for Plumbing Equipment
Section 22 0517	Sleeves and Seals for Plumbing Piping
Section 22 0518	Escutcheons for Plumbing Piping
Section 22 0523	General Duty Valves for Plumbing Piping
Section 22 0529	Hangers and Supports for Plumbing Piping and Equipment
Section 22 0548	Vibration and Seismic Control for Plumbing Piping and Equipment
Section 22 0553	Identification for Plumbing Piping and Equipment
Section 22 0719	Plumbing Piping Insulation
Section 22 1116	Domestic Water Piping
Section 22 1119	Domestic Water Piping Specialties
Section 22 1316	Sanitary Waste and Vent Piping
Section 22 1319	Sanitary Waste Piping Specialties
Section 22 6113	Compressed-Air Piping for Laboratory and Healthcare Facilities
Section 22 6213	Vacuum Piping for Laboratory and Healthcare Facilities
Section 22 6314	Medical Gas Piping

THIS PAGE LEFT BLANK INTENTIONALLY

SECTION 22 0500

COMMON WORK RESULTS FOR PLUMBING

PART 1 - GENERAL

1.1 RELATED DOCUMENTS

- A. Drawings and general provisions of the Contract, including General and Supplementary Conditions and Division 01 Specification Sections, apply to this Section.

1.2 SUMMARY

- A. This Section includes the following:
 1. Piping materials and installation instructions common to most piping systems.
 2. Equipment installation requirements common to equipment sections.
 3. Painting and finishing.
 4. Supports and anchorages.

1.3 SEISMIC REQUIREMENTS

- A. Seismic Performance: Equipment, pipe hangers and supports shall withstand the effects of earthquake motions determined according to SEI/ASCE 7 and with the requirements specified in Section 220548 "Vibration and Seismic Controls for Plumbing Piping and Equipment."
 1. For components with a seismic importance factor of 1.0 the term "withstand" means "the system will remain in place without separation of any parts when subjected to the seismic forces specified."
 2. For components with a seismic importance factor of 1.5 the term "withstand" means "the system will remain in place without separation of any parts when subjected to the seismic forces specified and the system will be fully operational after the seismic event."

1.4 DEFINITIONS

- A. Finished Spaces: Spaces other than mechanical and electrical equipment rooms, furred spaces, pipe chases, unheated spaces immediately below roof, spaces above ceilings, unexcavated spaces, and crawlspaces.
- B. Exposed, Interior Installations: Exposed to view indoors. Examples include finished occupied spaces and mechanical equipment rooms, accessible pipe shafts, accessible plumbing chases and accessible tunnels.
- C. Exposed, Exterior Installations: Exposed to view outdoors or subject to outdoor ambient temperatures and weather conditions. Examples include rooftop locations.
- D. Concealed, Interior Installations: Concealed from view and protected from physical contact by building occupants. Examples include above ceilings and in chases.
- E. Concealed, Exterior Installations: Concealed from view and protected from weather conditions and physical contact by building occupants but subject to outdoor ambient temperatures. Examples include installations within unheated shelters.

- F. The following are industry abbreviations for rubber materials:
 - 1. EPDM: Ethylene-propylene-diene terpolymer rubber.
 - 2. NBR: Acrylonitrile-butadiene rubber.

1.5 SUBMITTALS

- A. Product Data: For the following:
 - 1. Transition fittings.
- B. Welding certificates.

1.6 QUALITY ASSURANCE

- A. Steel Support Welding: Qualify processes and operators according to AWS D1.1, "Structural Welding Code--Steel."
- B. Electrical Characteristics for Plumbing Equipment: Equipment of higher electrical characteristics may be furnished provided such proposed equipment is approved in writing and connecting electrical services, circuit breakers, and conduit sizes are appropriately modified. If minimum energy ratings or efficiencies are specified, equipment shall comply with requirements.

1.7 DELIVERY, STORAGE, AND HANDLING

- A. Deliver pipes and tubes with factory-applied end caps. Maintain end caps through shipping, storage, and handling to prevent pipe end damage and to prevent entrance of dirt, debris, and moisture. Store piping off of the ground and floors.
- B. Store plastic pipes protected from direct sunlight. Support to prevent sagging and bending.

1.8 COORDINATION

- A. Arrange for pipe spaces, chases, slots, and openings in building structure during progress of construction, to allow for plumbing installations.
- B. Coordinate installation of required supporting devices and set sleeves in poured-in-place concrete and other structural components as they are constructed.
- C. Coordinate requirements for access panels and doors for plumbing items requiring access that are concealed behind finished surfaces. Access panels and doors are specified in Division 08 Section "Access Doors and Frames."

PART 2 - PRODUCTS

2.1 MANUFACTURERS

- A. In other Part 2 articles where subparagraph titles below introduce lists, the following requirements apply for product selection:
 - 1. Manufacturers: Subject to compliance with requirements, provide products by the manufacturers specified.

2.2 PIPE, TUBE, AND FITTINGS

- A. Refer to individual Division 22 piping Sections for pipe, tube, and fitting materials and joining methods.
- B. Pipe Threads: ASME B1.20.1 for factory-threaded pipe and pipe fittings.

2.3 JOINING MATERIALS

- A. Refer to individual Division 22 piping Sections for special joining materials not listed below.
- B. Pipe-Flange Gasket Materials: Suitable for chemical and thermal conditions of piping system contents.
 - 1. ASME B16.21, nonmetallic, flat, asbestos-free, 1/8-inch maximum thickness unless thickness or specific material is indicated.
 - a. Full-Face Type: For flat-face, Class 125, cast-iron and cast-bronze flanges.
 - b. Narrow-Face Type: For raised-face, Class 250, cast-iron and steel flanges.
 - 2. AWWA C110, rubber, flat face, 1/8 inch thick, unless otherwise indicated; and full-face or ring type, unless otherwise indicated.
- C. Flange Bolts and Nuts: ASME B18.2.1, carbon steel, unless otherwise indicated.
- D. Solder Filler Metals: ASTM B 32, lead-free alloys. Include water-flushable flux according to ASTM B 813.
- E. Brazing Filler Metals: AWS A5.8, BCuP Series, copper-phosphorus alloys for general-duty brazing, unless otherwise indicated; and AWS A5.8, BAg1, silver alloy for refrigerant piping, unless otherwise indicated.

PART 3 - EXECUTION

3.1 SEISMIC REQUIREMENTS

- A. Comply with SEI/ASCE 7 and with requirements for seismic seismic-restraint devices in Section 220548 "Vibration and Seismic Controls for Plumbing Piping and Equipment."

3.2 PIPING SYSTEMS - COMMON REQUIREMENTS

- A. Install piping according to the following requirements and Division 22 Sections specifying piping systems.
- B. Drawing plans, schematics, and diagrams indicate general location and arrangement of piping systems. Indicated locations and arrangements were used to size pipe and calculate friction loss, expansion, pump sizing, and other design considerations. Install piping as indicated unless deviations to layout are approved on Coordination Drawings.
- C. Install piping in concealed locations, unless otherwise indicated and except in equipment rooms and service areas.
- D. Install piping indicated to be exposed and piping in equipment rooms and service areas at right angles or parallel to building walls. Diagonal runs are prohibited unless specifically indicated otherwise.

- E. Install piping above accessible ceilings to allow sufficient space for ceiling panel removal.
- F. Install piping to permit valve servicing.
- G. Install piping at indicated slopes.
- H. Install piping free of sags and bends.
- I. Install fittings for changes in direction and branch connections.
- J. Install piping to allow application of insulation.
- K. Select system components with pressure rating equal to or greater than system operating pressure.
- L. Fire-Barrier Penetrations: Maintain indicated fire rating of walls, partitions, ceilings, and floors at pipe penetrations. Seal pipe penetrations with firestop materials. Refer to Division 07 Section "Penetration Firestopping" for materials.
- M. Verify final equipment locations for roughing-in.
- N. Refer to equipment specifications in other Sections of these Specifications for roughing-in requirements.

3.3 PIPING JOINT CONSTRUCTION

- A. Join pipe and fittings according to the following requirements and Division 22 Sections specifying piping systems.
- B. Ream ends of pipes and tubes and remove burrs. Bevel plain ends of steel pipe.
- C. Remove scale, slag, dirt, and debris from inside and outside of pipe and fittings before assembly.
- D. Soldered Joints: Apply ASTM B 813, water-flushable flux, unless otherwise indicated, to tube end. Construct joints according to ASTM B 828 or CDA's "Copper Tube Handbook," using lead-free solder alloy complying with ASTM B 32.
- E. Brazed Joints: Construct joints according to AWS's "Brazing Handbook," "Pipe and Tube" Chapter, using copper-phosphorus brazing filler metal complying with AWS A5.8.
- F. Threaded Joints: Thread pipe with tapered pipe threads according to ASME B1.20.1. Cut threads full and clean using sharp dies. Ream threaded pipe ends to remove burrs and restore full ID. Join pipe fittings and valves as follows:
 - 1. Apply appropriate tape or thread compound to external pipe threads unless dry seal threading is specified.
 - 2. Damaged Threads: Do not use pipe or pipe fittings with threads that are corroded or damaged. Do not use pipe sections that have cracked or open welds.
- G. Welded Joints: Construct joints according to AWS D10.12, using qualified processes and welding operators according to Part 1 "Quality Assurance" Article.
- H. Flanged Joints: Select appropriate gasket material, size, type, and thickness for service application. Install gasket concentrically positioned. Use suitable lubricants on bolt threads.

3.4 PIPING CONNECTIONS

- A. Make connections according to the following, unless otherwise indicated:
 - 1. Install unions, in piping NPS 2 and smaller, adjacent to each valve and at final connection to each piece of equipment.
 - 2. Install flanges, in piping NPS 2-1/2 and larger, adjacent to flanged valves and at final connection to each piece of equipment.
 - 3. Dry Piping Systems: Install dielectric unions and flanges to connect piping materials of dissimilar metals.
 - 4. Wet Piping Systems: Install dielectric coupling and nipple fittings to connect piping materials of dissimilar metals.

3.5 EQUIPMENT INSTALLATION - COMMON REQUIREMENTS

- A. Install equipment to allow maximum possible headroom unless specific mounting heights are not indicated.
- B. Install equipment level and plumb, parallel and perpendicular to other building systems and components in exposed interior spaces, unless otherwise indicated.
- C. Install plumbing equipment to facilitate service, maintenance, and repair or replacement of components. Connect equipment for ease of disconnecting, with minimum interference to other installations. Extend grease fittings to accessible locations.
- D. Install equipment to allow right of way for piping installed at required slope.

3.6 PAINTING

- A. Painting of plumbing systems, equipment, and components is specified in Division 09 Sections "Interior Painting" and "Exterior Painting."
- B. Damage and Touchup: Repair marred and damaged factory-painted finishes with materials and procedures to match original factory finish.

3.7 ERECTION OF METAL SUPPORTS AND ANCHORAGES

- A. Refer to Division 05 Section "Metal Fabrications" for structural steel.
- B. Cut, fit, and place miscellaneous metal supports accurately in location, alignment, and elevation to support and anchor plumbing materials and equipment.
- C. Field Welding: Comply with AWS D1.1.

3.8 ERECTION OF WOOD SUPPORTS AND ANCHORAGES

- A. Cut, fit, and place wood grounds, nailers, blocking, and anchorages to support, and anchor plumbing materials and equipment.
- B. Select fastener sizes that will not penetrate members if opposite side will be exposed to view or will receive finish materials. Tighten connections between members. Install fasteners without splitting wood members.
- C. Attach to substrates as required to support applied loads.

END OF SECTION 22 0500

SECTION 22 0513

COMMON MOTOR REQUIREMENTS FOR PLUMBING EQUIPMENT

PART 1 - GENERAL

1.1 RELATED DOCUMENTS

- A. Drawings and general provisions of the Contract, including General and Supplementary Conditions and Division 01 Specification Sections, apply to this Section.

1.2 SUMMARY

- A. Section includes general requirements for single-phase and polyphase, general-purpose, horizontal, small and medium, squirrel-cage induction motors for use on ac power systems up to 600 V and installed at equipment manufacturer's factory or shipped separately by equipment manufacturer for field installation.

1.3 COORDINATION

- A. Coordinate features of motors, installed units, and accessory devices to be compatible with the following:
 - 1. Motor controllers.
 - 2. Torque, speed, and horsepower requirements of the load.
 - 3. Ratings and characteristics of supply circuit and required control sequence.
 - 4. Ambient and environmental conditions of installation location.

PART 2 - PRODUCTS

2.1 GENERAL MOTOR REQUIREMENTS

- A. Comply with requirements in this Section except when the requirements in plumbing equipment schedules, other specification sections, drawing notes or in other contract documents are more stringent.
- B. Comply with NEMA MG 1 unless otherwise indicated.
- C. Comply with IEEE 841 for severe-duty motors.

2.2 MOTOR CHARACTERISTICS

- A. Duty: Continuous duty at ambient temperature of and at altitude of 3300 feet above sea level.
- B. Capacity and Torque Characteristics: Sufficient to start, accelerate, and operate connected loads at designated speeds, at installed altitude and environment, with indicated operating sequence, and without exceeding nameplate ratings or considering service factor.

2.3 POLYPHASE MOTORS

- A. Description: NEMA MG 1, Design B, medium induction motor.
- B. Efficiency: Energy efficient, as defined in NEMA MG 1.
- C. Service Factor: 1.15.
- D. Rotor: Random-wound, squirrel cage.
- E. Bearings: Regreasable, shielded, antifriction ball bearings suitable for radial and thrust loading.
- F. Temperature Rise: Match insulation rating.
- G. Insulation: Class F. Code Letter Designation:
 - 1. Motors 15 HP and Larger: NEMA starting Code F or Code G.
 - 2. Motors smaller than 15 HP: Manufacturer's standard starting characteristic.
- H. Enclosure Material: Cast iron for motor frame sizes 324T and larger; rolled steel for motor frame sizes smaller than 324T.

2.4 POLYPHASE MOTORS WITH ADDITIONAL REQUIREMENTS

- A. Motors Used with Reduced-Voltage and Multispeed Controllers: Match wiring connection requirements for controller with required motor leads. Provide terminals in motor terminal box, suited to control method.
- B. Motors Used with Variable Frequency Controllers: Ratings, characteristics, and features coordinated with and approved by controller manufacturer.
 - 1. Windings: Copper magnet wire with moisture-resistant insulation varnish, designed and tested to resist transient spikes, high frequencies, and short time rise pulses produced by pulse-width modulated inverters.
 - 2. Energy- and Premium-Efficient Motors: Class B temperature rise; Class F insulation.
 - 3. Inverter-Duty Motors: Class F temperature rise; Class H insulation.
 - 4. Thermal Protection: Comply with NEMA MG 1 requirements for thermally protected motors.
 - 5. Shaft Grounding Ring: Microfiber type.
 - a. Provide grounded discharge path for VFD induced voltage in the shaft to prevent arching in the motor bearings.

2.5 ELECTRICALLY COMMUTATED MOTOR (ECM)

1. Motor enclosures: Open type
2. Motor to be a DC electronic commutation type motor (ECM).
 - a. AC induction type motors are not acceptable.
3. Permanently lubricated motor with heavy duty ball bearing
4. Internal motor circuitry to convert AC power supplied to the fan to DC power to operate the motor.
5. Speed controllable to 20% of full speed (80% turndown).
 - a. Potentiometer dial mounted at the motor speed controller
 - b. 0-10 VDC signal.
6. 85% efficient at all speeds minimum.
7. Motors smaller than 2.0 hp.

2.6 SINGLE-PHASE MOTORS

- A. Motors larger than 1/20 hp shall be one of the following, to suit starting torque and requirements of specific motor application:
 1. Permanent-split capacitor.
 2. Split phase.
 3. Capacitor start, inductor run.
 4. Capacitor start, capacitor run.
- B. Multispeed Motors: Variable-torque, permanent-split-capacitor type.
- C. Bearings: Prelubricated, antifriction ball bearings or sleeve bearings suitable for radial and thrust loading.
- D. Motors 1/20 HP and Smaller: Shaded-pole type.
- E. Thermal Protection: Internal protection to automatically open power supply circuit to motor when winding temperature exceeds a safe value calibrated to temperature rating of motor insulation. Thermal-protection device shall automatically reset when motor temperature returns to normal range.

PART 3 - EXECUTION (Not Applicable)

END OF SECTION 22 0513

THIS PAGE LEFT BLANK INTENTIONALLY

SECTION 22 0517

SLEEVES AND SLEEVE SEALS FOR PLUMBING PIPING

PART 1 - GENERAL

1.1 RELATED DOCUMENTS

- A. Drawings and general provisions of the Contract, including General and Supplementary Conditions and Division 01 Specification Sections, apply to this Section.

1.2 SUMMARY

- A. Section Includes:
 - 1. Sleeves.
 - 2. Sleeve-seal systems.
 - 3. Grout.

1.3 ACTION SUBMITTALS

- A. Product Data: For each type of product indicated.

PART 2 - PRODUCTS

2.1 SLEEVES

- A. Cast-Iron Wall Pipes: Cast or fabricated of cast or ductile iron and equivalent to ductile-iron pressure pipe, with plain ends and integral waterstop unless otherwise indicated.
- B. Galvanized-Steel Wall Pipes: ASTM A 53, Schedule 40, with plain ends and welded steel collar; zinc coated.
- C. Galvanized-Steel-Pipe Sleeves: ASTM A 53, Type E, Grade B, Schedule 40, zinc coated, with plain ends.
- D. PVC-Pipe Sleeves: ASTM D 1785, Schedule 40.
- E. Galvanized-Steel-Sheet Sleeves: 0.0239-inch minimum thickness; round tube closed with welded longitudinal joint.

2.2 SLEEVE-SEAL SYSTEMS

- A. Manufacturers: Subject to compliance with requirements, provide products by one of the following:
 - 1. Advance Products & Systems, Inc.
 - 2. CALPICO, Inc.
 - 3. Link-Seal
 - 4. Metraflex Company (The).
 - 5. Pipeline Seal and Insulator, Inc.

6. Proco Products, Inc.
 7. Hilti, cast in place system
- B. Description: Modular sealing-element unit, designed for field assembly, for filling annular space between piping and sleeve.
1. Sealing Elements: EPDM-rubber interlocking links shaped to fit surface of pipe. Include type and number required for pipe material and size of pipe.
 2. Pressure Plates: Carbon steel.
 3. Connecting Bolts and Nuts: Carbon steel, with corrosion-resistant coating, of length required to secure pressure plates to sealing elements.

2.3 GROUT

- A. Standard: ASTM C 1107, Grade B, post-hardening and volume-adjusting, dry, hydraulic-cement grout.
- B. Characteristics: Nonshrink; recommended for interior and exterior applications.
- C. Design Mix: 5000-psi, 28-day compressive strength.
- D. Packaging: Premixed and factory packaged.

PART 3 - EXECUTION

3.1 SLEEVE INSTALLATION

- A. Install sleeves for piping passing through penetrations in floors, partitions, roofs, and walls.
- B. For sleeves that will have sleeve-seal system installed, select sleeves of size large enough to provide 1-inch annular clear space between piping and concrete slabs and walls.
1. Sleeves are not required for core-drilled holes.
- C. Install sleeves in concrete floors, concrete roof slabs, and concrete walls as new slabs and walls are constructed.
1. Permanent sleeves are not required for holes in slabs formed by molded-PE or -PP sleeves.
 2. Cut sleeves to length for mounting flush with both surfaces.
 - a. Exception: Extend sleeves installed in floors of mechanical equipment areas or other wet areas 2 inches above finished floor level.
 3. Using grout, seal the space outside of sleeves in slabs and walls without sleeve-seal system.
- D. Install sleeves for pipes passing through interior partitions.
1. Cut sleeves to length for mounting flush with both surfaces.
 2. Install sleeves that are large enough to provide 1/4-inch annular clear space between sleeve and pipe or pipe insulation.
 3. Seal annular space between sleeve and piping or piping insulation; use joint sealants appropriate for size, depth, and location of joint. Comply with requirements for sealants specified in Division 07 Section "Joint Sealants."

4. For sound-rated partitions, fill the opening between sleeve and piping with insulation prior to sealing.
- E. Fire-Barrier Penetrations: Maintain indicated fire rating of walls, partitions, ceilings, and floors at pipe penetrations. Seal pipe penetrations with firestop materials. Comply with requirements for firestopping specified in Division 07 Section "Penetration Firestopping."

3.2 SLEEVE-SEAL-SYSTEM INSTALLATION

- A. Install sleeve-seal systems in sleeves in exterior concrete walls and slabs-on-grade at service piping entries into building.
- B. Select type, size, and number of sealing elements required for piping material and size and for sleeve ID or hole size. Position piping in center of sleeve. Center piping in penetration, assemble sleeve-seal system components, and install in annular space between piping and sleeve. Tighten bolts against pressure plates that cause sealing elements to expand and make a watertight seal.

3.3 SLEEVE AND SLEEVE-SEAL SCHEDULE

- A. Use sleeves and sleeve seals for the following piping-penetration applications:
 1. Exterior Concrete Walls above Grade:
 - a. Piping Smaller Than NPS 6: Cast-iron wall sleeves.
 - b. Piping NPS 6 and Larger: Cast-iron wall sleeves.
 2. Exterior Concrete Walls below Grade:
 - a. Piping Smaller Than NPS 6: Cast-iron wall sleeves with sleeve-seal system.
 - 1) Select sleeve size to allow for 1-inch annular clear space between piping and sleeve for installing sleeve-seal system.
 - b. Piping NPS 6 and Larger: Cast-iron wall sleeves with sleeve-seal system.
 - 1) Select sleeve size to allow for 1-inch annular clear space between piping and sleeve for installing sleeve-seal system.
 3. Concrete Slabs-on-Grade:
 - a. Piping Smaller Than NPS 6: Cast-iron wall sleeves with sleeve-seal system.
 - 1) Select sleeve size to allow for 1-inch annular clear space between piping and sleeve for installing sleeve-seal system.
 - b. Piping NPS 6 and Larger: Cast-iron wall sleeves with sleeve-seal system.
 - 1) Select sleeve size to allow for 1-inch annular clear space between piping and sleeve for installing sleeve-seal system.
 4. Concrete Slabs above Grade:
 - a. Piping Smaller Than NPS 6: Galvanized-steel-pipe sleeves.
 - b. Piping NPS 6 and Larger: Galvanized-steel-pipe sleeves.
 5. Interior Partitions:

- a. Piping Smaller Than NPS 6: Galvanized-steel-pipe sleeves.
- b. Piping NPS 6 and Larger: Galvanized-steel-sheet sleeves.

END OF SECTION 22 0517

SECTION 22 0518

ESCUTCHEONS FOR PLUMBING PIPING

PART 1 - GENERAL

1.1 RELATED DOCUMENTS

- A. Drawings and general provisions of the Contract, including General and Supplementary Conditions and Division 01 Specification Sections, apply to this Section.

1.2 SUMMARY

- A. Section Includes:
 - 1. Escutcheons.

1.3 ACTION SUBMITTALS

- A. Product Data: For each type of product indicated.

PART 2 - PRODUCTS

2.1 ESCUTCHEONS

- A. One-Piece, Cast-Brass Type: With polished, chrome-plated finish and setscrew fastener.
- B. One-Piece, Deep-Pattern Type: Deep-drawn, box-shaped brass with chrome-plated finish and spring-clip fasteners.
- C. One-Piece, Stamped-Steel Type: With chrome-plated finish and spring-clip fasteners.

PART 3 - EXECUTION

3.1 INSTALLATION

- A. Install escutcheons for piping penetrations of walls, ceilings, and finished floors.
- B. Install escutcheons with ID to 2 inch (50mm), tube, and insulation of insulated piping and with OD that completely covers opening.
 - 1. Escutcheons for New Piping:
 - a. Piping with Fitting or Sleeve Protruding from Wall: One-piece, deep-pattern type with polished, chrome-plated finish.
 - b. Chrome-Plated Piping: One-piece, cast-brass type with polished, chrome-plated finish.
 - c. Insulated Piping: One-piece, stamped-steel type with chrome-plated finish.

- d. Bare Piping 2 inch and Smaller at Wall and Floor Penetrations in Finished Spaces: One-piece, cast-brass type with polished, chrome-plated finish.
 - e. Bare Piping Larger than 2 inch at Wall and Floor Penetrations in Finished Spaces: One-piece, stamped-steel type with polished, chrome-plated finish.
 - f. Bare Piping 2 inch and Smaller at Ceiling Penetrations in Finished Spaces: One-piece, cast-brass type with polished, chrome-plated finish.
 - g. Bare Piping Larger than 2 inch at Ceiling Penetrations in Finished Spaces: One-piece, stamped-steel type with polished, chrome-plated finish.
 - h. Bare Piping 2 inch and Smaller in Unfinished Service Spaces: One-piece, cast-brass type with polished, chrome-plated or rough-brass finish.
 - i. Bare Piping Larger than 2 inch in Unfinished Service Spaces: One-piece, stamped-steel type with polished, chrome-plated finish.
 - j. Bare Piping 2 inch and Smaller in Equipment Rooms: One-piece, cast-brass type with polished, chrome-plated or rough-brass finish.
 - k. Bare Piping in Equipment Rooms Larger than 2 inch: One-piece, stamped-steel type with chrome- or cadmium-plated finish.
3. Escutcheons for Existing Piping to Remain:
- a. Chrome-Plated Piping: Split-casting, stamped steel with concealed or exposed-rivet hinge with polished, chrome-plated finish.
 - b. Insulated Piping: Split-plate, stamped steel with concealed or exposed-rivet hinge with polished, chrome-plated finish
 - c. Bare Piping at Wall and Floor Penetrations in Finished Spaces: Split-plate, stamped steel with concealed or exposed-rivet hinge with polished, chrome-plated finish.
 - d. Bare Piping at Ceiling Penetrations in Finished Spaces: Split-plate, stamped steel with concealed or exposed-rivet hinge with polished, chrome-plated finish.
 - e. Bare Piping in Unfinished Service Spaces: Split-plate, stamped steel with concealed or exposed-rivet hinge with polished, chrome-plated finish.
 - f. Bare Piping in Equipment Rooms: Split-plate, stamped steel with concealed or exposed-rivet hinge with polished, chrome-plated finish.

3.2 FIELD QUALITY CONTROL

- A. Replace broken and damaged escutcheons and floor plates using new materials.

END OF SECTION 22 0518

SECTION 22 0523

GENERAL-DUTY VALVES FOR PLUMBING PIPING

PART 1 - GENERAL

1.1 RELATED DOCUMENTS

- A. Drawings and general provisions of the Contract, including General and Supplementary Conditions and Division 01 Specification Sections, apply to this Section.

1.2 SUMMARY

A. Section Includes:

1. Bronze angle valves.
2. Bronze ball valves.
3. Bronze lift check valves.
4. Bronze swing check valves.
5. Bronze gate valves.
6. Bronze globe valves.

B. Related Sections:

1. Division 22 plumbing piping Sections for specialty valves applicable to those Sections only.
2. Division 22 Section "Identification for Plumbing Piping and Equipment" for valve tags and schedules.

1.3 DEFINITIONS

- A. CWP: Cold working pressure.
- B. EPDM: Ethylene propylene copolymer rubber.
- C. NBR: Acrylonitrile-butadiene, Buna-N, or nitrile rubber.
- D. NRS: Nonrising stem.
- E. OS&Y: Outside screw and yoke.
- F. RS: Rising stem.
- G. SWP: Steam working pressure.

1.4 SUBMITTALS

- A. Product Data: For each type of valve indicated.

1.5 QUALITY ASSURANCE

- A. Source Limitations for Valves: Obtain each type of valve from single manufacturer.

- B. ASME Compliance:
 - 1. ASME B16.10 and ASME B16.34 for ferrous valve dimensions and design criteria.
 - 2. ASME B31.1 for power piping valves.
 - 3. ASME B31.9 for building services piping valves.
- C. NSF Compliance: NSF 61 for valve materials for potable-water service.

1.6 DELIVERY, STORAGE, AND HANDLING

- A. Prepare valves for shipping as follows:
 - 1. Protect internal parts against rust and corrosion.
 - 2. Protect threads, flange faces, grooves, and weld ends.
 - 3. Set angle, gate, and globe valves closed to prevent rattling.
 - 4. Set ball and plug valves open to minimize exposure of functional surfaces.
 - 5. Block check valves in either closed or open position.
- B. Use the following precautions during storage:
 - 1. Maintain valve end protection.
 - 2. Store valves indoors and maintain at higher than ambient dew point temperature. If outdoor storage is necessary, store valves off the ground in watertight enclosures.
- C. Use sling to handle large valves; rig sling to avoid damage to exposed parts. Do not use handwheels or stems as lifting or rigging points.

PART 2 - PRODUCTS

2.1 GENERAL REQUIREMENTS FOR VALVES

- A. Refer to valve schedule articles for applications of valves.
- B. Valve Pressure and Temperature Ratings: Not less than indicated and as required for system pressures and temperatures.
- C. Valve Sizes: Same as upstream piping unless otherwise indicated.
- D. Valve Actuator Types:
 - 1. Gear Actuator: For quarter-turn valves NPS 8 and larger.
 - 2. Handwheel: For valves other than quarter-turn types.
 - 3. Handlever: For quarter-turn valves NPS 6 and smaller except plug valves.
 - 4. Wrench: For plug valves with square heads. Furnish Owner with 1 wrench for every 5 plug valves, for each size square plug-valve head.
- E. Valves in Insulated Piping: With 2-inch stem extensions and the following features:
 - 1. Gate Valves: With rising stem.
 - 2. Ball Valves: With extended operating handle of non-thermal-conductive material, and protective sleeve that allows operation of valve without breaking the vapor seal or disturbing insulation.
- F. Valve-End Connections:

1. Flanged: With flanges according to ASME B16.1 for iron valves.
2. Grooved: With grooves according to AWWA C606.
3. Solder Joint: With sockets according to ASME B16.18.
4. Threaded: With threads according to ASME B1.20.1.

G. Valve Bypass and Drain Connections: MSS SP-45.

2.2 BRONZE ANGLE VALVES

A. Class 125, Bronze Angle Valves with Bronze Disc:

1. Manufacturers: Subject to compliance with requirements, provide products by one of the following:
 - a. Hammond Valve.
 - b. Milwaukee Valve Company.
2. Description:
 - a. Standard: MSS SP-80, Type 1.
 - b. CWP Rating: 200 psig.
 - c. Body Material: ASTM B 62, bronze with integral seat and screw-in bonnet.
 - d. Ends: Threaded.
 - e. Stem and Disc: Bronze.
 - f. Packing: Asbestos free.
 - g. Handwheel: Malleable iron, bronze, or aluminum.

2.3 BRONZE BALL VALVES

A. Two-Piece, Full-Port, Bronze Ball Valves with Bronze Trim:

1. Manufacturers: Subject to compliance with requirements, provide products by one of the following:
 - a. American Valve, Inc.
 - b. Conbraco Industries, Inc.; Apollo Valves.
 - c. Crane Co.; Crane Valve Group; Crane Valves.
 - d. Hammond Valve.
 - e. Lance Valves; a division of Advanced Thermal Systems, Inc.
 - f. Milwaukee Valve Company.
 - g. NIBCO INC.
 - h. Red-White Valve Corporation.
 - i. Watts Regulator Co.; a division of Watts Water Technologies, Inc.
2. Description:
 - a. Standard: MSS SP-110.
 - b. SWP Rating: 150 psig.
 - c. CWP Rating: 600 psig.
 - d. Body Design: Two piece.
 - e. Body Material: Bronze.
 - f. Ends: Threaded.
 - g. Seats: PTFE.
 - h. Stem: Bronze.
 - i. Ball: Chrome-plated brass.
 - j. Port: Full.

k. Class: 250

B. Two-Piece, Full-Port, Bronze Ball Valves with Stainless-Steel Trim:

1. Manufacturers: Subject to compliance with requirements, provide products by one of the following:
 - a. Conbraco Industries, Inc.; Apollo Valves.
 - b. Crane Co.; Crane Valve Group; Crane Valves.
 - c. Hammond Valve.
 - d. Lance Valves; a division of Advanced Thermal Systems, Inc.
 - e. Milwaukee Valve Company.
 - f. NIBCO INC.
 - g. Watts Regulator Co.; a division of Watts Water Technologies, Inc.
2. Description:
 - a. Standard: MSS SP-110.
 - b. SWP Rating: 150 psig.
 - c. CWP Rating: 600 psig.
 - d. Body Design: Two piece.
 - e. Body Material: Bronze.
 - f. Ends: Threaded.
 - g. Seats: PTFE.
 - h. Stem: Stainless steel.
 - i. Ball: Stainless steel, vented.
 - j. Port: Full.
 - k. Class: 250

C. Three-Piece, Full-Port, Bronze Ball Valves with Bronze Trim:

1. Manufacturers: Subject to compliance with requirements, provide products by one of the following:
 - a. Conbraco Industries, Inc.; Apollo Valves.
 - b. DynaQuip Controls.
 - c. Hammond Valve.
 - d. Milwaukee Valve Company.
 - e. NIBCO INC.
 - f. Red-White Valve Corporation.
2. Description:
 - a. Standard: MSS SP-110.
 - b. SWP Rating: 150 psig.
 - c. CWP Rating: 600 psig.
 - d. Body Design: Three piece.
 - e. Body Material: Bronze.
 - f. Ends: Threaded.
 - g. Seats: PTFE.
 - h. Stem: Bronze.
 - i. Ball: Chrome-plated brass.
 - j. Port: Full.
 - k. Class: 250

D. Three-Piece, Full-Port, Bronze Ball Valves with Stainless-Steel Trim:

1. Manufacturers: Subject to compliance with requirements, provide products by one of the following:
 - a. Conbraco Industries, Inc.; Apollo Valves.
 - b. Hammond Valve.
 - c. Milwaukee Valve Company.
 - d. NIBCO INC.

2. Description:
 - a. Standard: MSS SP-110.
 - b. SWP Rating: 150 psig.
 - c. CWP Rating: 600 psig.
 - d. Body Design: Three piece.
 - e. Body Material: Bronze.
 - f. Ends: Threaded.
 - g. Seats: PTFE.
 - h. Stem: Stainless steel.
 - i. Ball: Stainless steel, vented.
 - j. Port: Full.
 - k. Class: 250

2.4 BRONZE LIFT CHECK VALVES

A. Class 125, Lift Check Valves with Bronze Disc:

1. Manufacturers: Subject to compliance with requirements, provide products by one of the following:
 - a. Crane Co.; Crane Valve Group; Crane Valves.
 - b. Crane Co.; Crane Valve Group; Jenkins Valves.
 - c. Crane Co.; Crane Valve Group; Stockham Division.

2. Description:
 - a. Standard: MSS SP-80, Type 1.
 - b. CWP Rating: 200 psig.
 - c. Body Design: Vertical flow.
 - d. Body Material: ASTM B 61 or ASTM B 62, bronze.
 - e. Ends: Threaded.
 - f. Disc: Bronze.

2.5 BRONZE SWING CHECK VALVES

A. Class 125, Bronze Swing Check Valves with Bronze Disc:

1. Manufacturers: Subject to compliance with requirements, provide products by one of the following:
 - a. American Valve, Inc.
 - b. Crane Co.; Crane Valve Group; Crane Valves.
 - c. Crane Co.; Crane Valve Group; Jenkins Valves.
 - d. Crane Co.; Crane Valve Group; Stockham Division.
 - e. Hammond Valve.
 - f. Kitz Corporation.
 - g. Milwaukee Valve Company.

- h. NIBCO INC.
- i. Powell Valves.
- j. Red-White Valve Corporation.
- k. Watts Regulator Co.; a division of Watts Water Technologies, Inc.
- l. Zy-Tech Global Industries, Inc.

2. Description:

- a. Standard: MSS SP-80, Type 3.
- b. CWP Rating: 200 psig.
- c. Body Design: Horizontal flow, Y pattern.
- d. Body Material: ASTM B 62, bronze.
- e. Ends: Threaded.
- f. Disc: Bronze.

B. Class 150, Bronze Swing Check Valves with Bronze Disc:

1. Manufacturers: Subject to compliance with requirements, provide products by one of the following:

- a. American Valve, Inc.
- b. Crane Co.; Crane Valve Group; Crane Valves.
- c. Crane Co.; Crane Valve Group; Jenkins Valves.
- d. Crane Co.; Crane Valve Group; Stockham Division.
- e. Kitz Corporation.
- f. Milwaukee Valve Company.
- g. NIBCO INC.
- h. Red-White Valve Corporation.
- i. Zy-Tech Global Industries, Inc.

2. Description:

- a. Standard: MSS SP-80, Type 3.
- b. CWP Rating: 300 psig.
- c. Body Design: Horizontal flow.
- d. Body Material: ASTM B 62, bronze.
- e. Ends: Threaded.
- f. Disc: Bronze.

2.6 BRONZE GLOBE VALVES

A. Class 125, Bronze Globe Valves with Bronze Disc:

1. Manufacturers: Subject to compliance with requirements, provide products by one of the following:

- a. Crane Co.; Crane Valve Group; Crane Valves.
- b. Crane Co.; Crane Valve Group; Stockham Division.
- c. Hammond Valve.
- d. Kitz Corporation.
- e. Milwaukee Valve Company.
- f. NIBCO INC.
- g. Powell Valves.
- h. Red-White Valve Corporation.
- i. Watts Regulator Co.; a division of Watts Water Technologies, Inc.
- j. Zy-Tech Global Industries, Inc.
- k. Conbraco

- I. Apollo
2. Description:
 - a. Standard: MSS SP-80, Type 1.
 - b. CWP Rating: 200 psig.
 - c. Body Material: ASTM B 62, bronze with integral seat and screw-in bonnet.
 - d. Ends: Threaded or solder joint.
 - e. Stem and Disc: Bronze.
 - f. Packing: Asbestos free.
 - g. Handwheel: Malleable iron, bronze, or aluminum.

PART 3 - EXECUTION

3.1 EXAMINATION

- A. Examine valve interior for cleanliness, freedom from foreign matter, and corrosion. Remove special packing materials, such as blocks, used to prevent disc movement during shipping and handling.
- B. Operate valves in positions from fully open to fully closed. Examine guides and seats made accessible by such operations.
- C. Examine threads on valve and mating pipe for form and cleanliness.
- D. Examine mating flange faces for conditions that might cause leakage. Check bolting for proper size, length, and material. Verify that gasket is of proper size, that its material composition is suitable for service, and that it is free from defects and damage.
- E. Do not attempt to repair defective valves; replace with new valves.

3.2 VALVE INSTALLATION

- A. Install valves with unions or flanges at each piece of equipment arranged to allow service, maintenance, and equipment removal without system shutdown.
- B. Locate valves for easy access and provide separate support where necessary.
- C. Install valves in horizontal piping with stem at or above center of pipe.
- D. Install valves in position to allow full stem movement.
- E. Install check valves for proper direction of flow and as follows:
 1. Swing Check Valves: In horizontal position with hinge pin level.
 2. Center-Guided and Plate-Type Check Valves: In horizontal or vertical position, between flanges.
 3. Lift Check Valves: With stem upright and plumb.

3.3 ADJUSTING

- A. Adjust or replace valve packing after piping systems have been tested and put into service but before final adjusting and balancing. Replace valves if persistent leaking occurs.

3.4 GENERAL REQUIREMENTS FOR VALVE APPLICATIONS

- A. If valve applications are not indicated, use the following:
 - 1. Shutoff Service: Ball or butterfly valves.
 - 2. Throttling Service Globe, angle, ball or butterfly valves.
- B. If valves with specified SWP classes or CWP ratings are not available, the same types of valves with higher SWP classes or CWP ratings may be substituted.
- C. Select valves, except wafer types, with the following end connections:
 - 1. For Copper Tubing, NPS 2 and Smaller: Threaded ends except where solder-joint valve-end option is indicated in valve schedules below.

3.5 LOW-PRESSURE, COMPRESSED-AIR VALVE SCHEDULE (150 PSIG OR LESS)

- A. Pipe NPS 2 and Smaller:
 - 1. Bronze Valves: May be provided with solder-joint ends instead of threaded ends.
 - 2. Ball Valves: One, Two, or Three piece, full, regular or reduced port, with brass, bronze or stainless-steel trim.
 - 3. Bronze Lift Check Valves: Class 125, bronze disc.
 - 4. Bronze Swing Check Valves: Class 125, bronze disc.

3.6 DOMESTIC, HOT- AND COLD-WATER VALVE SCHEDULE

- A. Pipe NPS 2 and Smaller:
 - 1. Bronze Valves: May be provided with solder-joint ends instead of threaded ends.
 - 2. Bronze Angle Valves: Class 125 or Class 150, bronze disc.
 - 3. Ball Valves: One, Two or Three piece, full, bronze with bronze or stainless-steel trim.
 - 4. Bronze Swing Check Valves: Class 125 or Class 150, bronze disc.
 - 5. Bronze Globe Valves: Class 125 or Class 150, bronze disc.

END OF SECTION 22 0523

SECTION 22 0529

HANGERS AND SUPPORTS FOR PLUMBING PIPING AND EQUIPMENT

PART 1 - GENERAL

1.1 RELATED DOCUMENTS

- A. Drawings and general provisions of the Contract, including General and Supplementary Conditions and Division 01 Specification Sections, apply to this Section.

1.2 SUMMARY

- A. This Section includes the following hangers and supports for plumbing system piping and equipment:
 - 1. Steel pipe hangers and supports.
 - 2. Trapeze pipe hangers.
 - 3. Metal framing systems.
 - 4. Thermal-hanger shield inserts.
 - 5. Fastener systems.
 - 6. Pipe positioning systems.
 - 7. Equipment supports.
- B. Related Sections include the following:
 - 1. Division 05 Section "Metal Fabrications" for structural-steel shapes and plates for trapeze hangers for pipe and equipment supports.
 - 2. Division 21 Section "Water-Based Fire-Suppression Systems" for pipe hangers for fire-suppression piping.
 - 3. Division 22 Section "Expansion Fittings and Loops for Plumbing Piping" for pipe guides and anchors.
 - 4. Division 22 Section "Vibration and Seismic Controls for Plumbing Piping and Equipment" for vibration isolation devices.

1.3 DEFINITIONS

- A. MSS: Manufacturers Standardization Society for The Valve and Fittings Industry Inc.
- B. Terminology: As defined in MSS SP-90, "Guidelines on Terminology for Pipe Hangers and Supports."

1.4 PERFORMANCE REQUIREMENTS

- A. Design supports for multiple pipes, including pipe stands, capable of supporting combined weight of supported systems, system contents, and test water.
- B. Design equipment supports capable of supporting combined operating weight of supported equipment and connected systems and components.
- C. Seismic Performance: Plumbing equipment, hangers and supports shall withstand the effects of earthquake motions determined according to SEI/ASCE 7 and with the requirements

specified in Section 220548 "Vibration and Seismic Controls for Plumbing Piping and Equipment.

1. For components with a seismic importance factor of 1.0 the term "withstand" means "the system will remain in place without separation of any parts when subjected to the seismic forces specified."
2. For components with a seismic importance factor of 1.5 the term "withstand" means "the system will remain in place without separation of any parts when subjected to the seismic forces specified and the system will be fully operational after the seismic event."

1.5 SUBMITTALS

A. Product Data: For the following:

1. Steel pipe hangers and supports.
2. Thermal-hanger shield inserts.
3. Powder-actuated fastener systems.
4. Pipe positioning systems.
5. Mechanical Anchors: ICC-ES Evaluation Reports validating 'Cracked Concrete' testing per A.C. 193 must be provided for anchors resisting seismic loads and/or supporting life-safety systems including fire sprinkler systems.

B. Shop Drawings: Signed and sealed by a qualified professional engineer. Show fabrication and installation details and include calculations for the following:

1. Trapeze pipe hangers. Include Product Data for components.
2. Metal framing systems. Include Product Data for components.
3. Equipment supports.

C. Welding certificates.

D. Delegated-Design Submittal:

1. Design calculations and detailed fabrication and assembly of pipe anchors and alignment guides, hangers and supports for multiple pipes, expansion joints and loops, and attachments of the same to the building structure.
2. Locations of pipe anchors and alignment guides and expansion joints and loops.
3. Locations of and details for penetrations, including sleeves and sleeve seals for exterior walls, floors, basement, and foundation walls.
4. Seismic calculations and detailed analysis: Indicate fabrication and arrangement. Detail attachments of restraints to the restrained items and to the structure. Show attachment locations, methods, and spacings. Identify components, list their strengths, and indicate directions and values of forces transmitted to the structure during seismic events. Indicate association with vibration isolation devices. Project specific design documentation and calculations shall be prepared and stamped by a registered professional engineer who is responsible for the seismic restraint design and who is licensed in the state where the project is being constructed (ASCE 7, 13.2.1.1).

1.6 QUALITY ASSURANCE

A. Welding: Qualify procedures and personnel according to AWS D1.1, "Structural Welding Code--Steel.", AWS D1.4, "Structural Welding Code--Reinforcing Steel." and ASME Boiler and Pressure Vessel Code: Section IX.

B. Welding: Qualify procedures and personnel according to the following:

1. AWS D1.1, "Structural Welding Code--Steel."
2. AWS D1.2, "Structural Welding Code--Aluminum."
3. AWS D1.4, "Structural Welding Code--Reinforcing Steel."
4. ASME Boiler and Pressure Vessel Code: Section IX.

PART 2 - PRODUCTS

2.1 MANUFACTURERS

- A. In other Part 2 articles where titles below introduce lists, the following requirements apply to product selection:
1. Manufacturers: Subject to compliance with requirements, provide products by one of the manufacturers specified.

2.2 STEEL PIPE HANGERS AND SUPPORTS

- A. Description: MSS SP-58, Types 1 through 58, factory-fabricated components. Refer to Part 3 "Hanger and Support Applications" Article for where to use specific hanger and support types.
- B. Manufacturers:
1. Anvil International.
 2. AAA Technology & Specialties Co., Inc.
 3. Bergen-Power Pipe Supports.
 4. B-Line Systems, Inc.; a division of Cooper Industries.
 5. Carpenter & Paterson, Inc.
 6. Empire Industries, Inc.
 7. ERICO/Michigan Hanger Co.
 8. Globe Pipe Hanger Products, Inc.
 9. Grinnell Corp.
 10. GS Metals Corp.
 11. National Pipe Hanger Corporation.
 12. PHD Manufacturing, Inc.
 13. PHS Industries, Inc.
 14. Piping Technology & Products, Inc.
 15. Tolco Inc.
 16. Simpson Strong-Tie Co.
- C. Galvanized, Metallic Coatings: Pregalvanized or hot dipped.
- D. Nonmetallic Coatings: Plastic coating, jacket, or liner.
- E. Padded Hangers: Hanger with fiberglass or other pipe insulation pad or cushion for support of bearing surface of piping.

2.3 TRAPEZE PIPE HANGERS

- A. Description: MSS SP-69, Type 59, shop- or field-fabricated pipe-support assembly made from structural-steel shapes with MSS SP-58 hanger rods, nuts, saddles, and U-bolts.

2.4 METAL FRAMING SYSTEMS

- A. Description: MFMA-3, shop- or field-fabricated pipe-support assembly made of steel channels and other components.
- B. Manufacturers:
 - 1. Anvil International.
 - 2. B-Line Systems, Inc.; a division of Cooper Industries.
 - 3. ERICO/Michigan Hanger Co.; ERISTRUT Div.
 - 4. GS Metals Corp.
 - 5. Hilti, Inc.
 - 6. Power-Strut Div.; Tyco International, Ltd.
 - 7. Thomas & Betts Corporation.
 - 8. Tolco Inc.
 - 9. Unistrut Corp.; Tyco International, Ltd.
- C. Coatings: Manufacturer's standard finish unless bare metal surfaces are indicated.
- D. Nonmetallic Coatings: Plastic coating, jacket, or liner.

2.5 THERMAL-HANGER SHIELD INSERTS

- A. Description: 100-psig- minimum, compressive-strength insulation insert encased in sheet metal shield.
- B. Manufacturers:
 - 1. Carpenter & Paterson, Inc.
 - 2. ERICO/Michigan Hanger Co.
 - 3. PHS Industries, Inc.
 - 4. Pipe Shields, Inc.
 - 5. Rilco Manufacturing Company, Inc.
 - 6. Value Engineered Products, Inc.
- C. Insulation-Insert Material for Cold Piping: Water-repellent treated, ASTM C 533, Type I calcium silicate with vapor barrier.
- D. Insulation-Insert Material for Hot Piping: Water-repellent treated, ASTM C 533, Type I calcium silicate.
- E. For Trapeze or Clamped Systems: Insert and shield shall cover entire circumference of pipe.
- F. For Clevis or Band Hangers: Insert and shield shall cover lower 180 degrees of pipe.
- G. Insert Length: Extend 2 inches beyond sheet metal shield for piping operating below ambient air temperature.

2.6 FASTENER SYSTEMS

- A. Powder-Actuated Fasteners: Threaded-steel stud, for use in hardened portland cement concrete with pull-out, tension, and shear capacities appropriate for supported loads and building materials where used.
 - 1. Manufacturers:

- a. Hilti, Inc.
 - b. MKT Fastening, LLC.
 - c. Powers Fasteners.
 - d. Simpson Strong-Tie Co.
- B. Mechanical-Expansion Anchors and Concrete Screws: Insert-wedge-type stainless steel, for use in hardened portland cement concrete with pull-out, tension, and shear capacities appropriate for supported loads and building materials where used. For anchors resisting seismic loads and/or supporting life- safety systems including fire sprinkler systems, Anchors shall have been tested for 'Cracked Concrete' per A.C. 193 per a valid ICC-ES Evaluation Report. Manufacturers with these anchors have been designated below with: '**'
1. Manufacturers:
 - a. B-Line Systems, Inc.; a division of Cooper Industries.
 - b. Empire Industries, Inc.
 - c. Hilti, Inc.
 - d. ITW Ramset/Red Head.
 - e. MKT Fastening, LLC.
 - f. Powers Fasteners.
 - g. Simpson Strong-Tie Co. *

2.7 PIPE POSITIONING SYSTEMS

- A. Description: IAPMO PS 42, system of metal brackets, clips, and straps for positioning piping in pipe spaces for plumbing fixtures for commercial applications.
- B. Manufacturers:
1. C & S Mfg. Corp.
 2. HOLDRITE Corp.; Hubbard Enterprises.
 3. Samco Stamping, Inc.

2.8 EQUIPMENT SUPPORTS

- A. Description: Welded, shop- or field-fabricated equipment support made from structural-steel shapes.

2.9 MISCELLANEOUS MATERIALS

- A. Structural Steel: ASTM A 36/A 36M, steel plates, shapes, and bars; black and galvanized.
- B. Grout: ASTM C 1107, factory-mixed and -packaged, dry, hydraulic-cement, nonshrink and nonmetallic grout; suitable for interior and exterior applications.
1. Properties: Nonstaining, noncorrosive, and nongaseous.
 2. Design Mix: 5000-psi, 28-day compressive strength.

PART 3 - EXECUTION

3.1 HANGER AND SUPPORT APPLICATIONS

- A. Specific hanger and support requirements are specified in Sections specifying piping systems and equipment.
- B. Comply with MSS SP-69 for pipe hanger selections and applications that are not specified in piping system Sections.
- C. Use hangers and supports with galvanized, metallic coatings for piping and equipment that will not have field-applied finish.
- D. Use nonmetallic coatings on attachments for electrolytic protection where attachments are in direct contact with copper tubing.
- E. Use padded hangers for piping that is subject to scratching.
- F. Horizontal-Piping Hangers and Supports: Unless otherwise indicated and except as specified in piping system Sections, install the following types:
 - 1. Adjustable, Steel Clevis Hangers (MSS Type 1): For suspension of noninsulated or insulated stationary pipes, NPS 1/2 to NPS 30.
 - 2. Yoke-Type Pipe Clamps (MSS Type 2): For suspension of 120 to 450 deg F pipes, NPS 4 to NPS 16, requiring up to 4 inches of insulation.
 - 3. Carbon- or Alloy-Steel, Double-Bolt Pipe Clamps (MSS Type 3): For suspension of pipes, NPS 3/4 to NPS 24, requiring clamp flexibility and up to 4 inches of insulation.
 - 4. Steel Pipe Clamps (MSS Type 4): For suspension of cold and hot pipes, NPS 1/2 to NPS 24, if little or no insulation is required.
 - 5. Pipe Hangers (MSS Type 5): For suspension of pipes, NPS 1/2 to NPS 4, to allow off-center closure for hanger installation before pipe erection.
 - 6. Adjustable, Swivel Split- or Solid-Ring Hangers (MSS Type 6): For suspension of noninsulated stationary pipes, NPS 3/4 to NPS 8.
 - 7. Adjustable, Steel Band Hangers (MSS Type 7): For suspension of noninsulated stationary pipes, NPS 1/2 to NPS 8.
 - 8. Adjustable Band Hangers (MSS Type 9): For suspension of noninsulated stationary pipes, NPS 1/2 to NPS 8.
 - 9. Adjustable, Swivel-Ring Band Hangers (MSS Type 10): For suspension of noninsulated stationary pipes, NPS 1/2 to NPS 2.
 - 10. Split Pipe-Ring with or without Turnbuckle-Adjustment Hangers (MSS Type 11): For suspension of noninsulated stationary pipes, NPS 3/8 to NPS 8.
 - 11. Extension Hinged or 2-Bolt Split Pipe Clamps (MSS Type 12): For suspension of noninsulated stationary pipes, NPS 3/8 to NPS 3.
 - 12. U-Bolts (MSS Type 24): For support of heavy pipes, NPS 1/2 to NPS 30.
 - 13. Clips (MSS Type 26): For support of insulated pipes not subject to expansion or contraction.
 - 14. Pipe Saddle Supports (MSS Type 36): For support of pipes, NPS 4 to NPS 36, with steel pipe base stanchion support and cast-iron floor flange.
 - 15. Pipe Stanchion Saddles (MSS Type 37): For support of pipes, NPS 4 to NPS 36, with steel pipe base stanchion support and cast-iron floor flange and with U-bolt to retain pipe.
 - 16. Adjustable, Pipe Saddle Supports (MSS Type 38): For stanchion-type support for pipes, NPS 2-1/2 to NPS 36, if vertical adjustment is required, with steel pipe base stanchion support and cast-iron floor flange.
 - 17. Single Pipe Rolls (MSS Type 41): For suspension of pipes, NPS 1 to NPS 30, from 2 rods if longitudinal movement caused by expansion and contraction might occur.

18. Adjustable Roller Hangers (MSS Type 43): For suspension of pipes, NPS 2-1/2 to NPS 20, from single rod if horizontal movement caused by expansion and contraction might occur.
 19. Complete Pipe Rolls (MSS Type 44): For support of pipes, NPS 2 to NPS 42, if longitudinal movement caused by expansion and contraction might occur but vertical adjustment is not necessary.
 20. Pipe Roll and Plate Units (MSS Type 45): For support of pipes, NPS 2 to NPS 24, if small horizontal movement caused by expansion and contraction might occur and vertical adjustment is not necessary.
 21. Adjustable Pipe Roll and Base Units (MSS Type 46): For support of pipes, NPS 2 to NPS 30, if vertical and lateral adjustment during installation might be required in addition to expansion and contraction.
- G. Vertical-Piping Clamps: Unless otherwise indicated and except as specified in piping system Sections, install the following types:
1. Extension Pipe or Riser Clamps (MSS Type 8): For support of pipe risers, NPS 3/4 to NPS 20.
 2. Carbon- or Alloy-Steel Riser Clamps (MSS Type 42): For support of pipe risers, NPS 3/4 to NPS 20, if longer ends are required for riser clamps.
- H. Hanger-Rod Attachments: Unless otherwise indicated and except as specified in piping system Sections, install the following types:
1. Steel Turnbuckles (MSS Type 13): For adjustment up to 6 inches for heavy loads.
 2. Steel Clevises (MSS Type 14): For 120 to 450 deg F piping installations.
 3. Swivel Turnbuckles (MSS Type 15): For use with MSS Type 11, split pipe rings.
 4. Malleable-Iron Sockets (MSS Type 16): For attaching hanger rods to various types of building attachments.
 5. Steel Weldless Eye Nuts (MSS Type 17): For 120 to 450 deg F piping installations.
- I. Building Attachments: Unless otherwise indicated and except as specified in piping system Sections, install the following types:
1. Steel or Malleable Concrete Inserts (MSS Type 18 or Simpson Blue Banger Concrete insert with UL & FM approvals): For upper attachment to suspend pipe hangers from concrete ceiling.
 2. Top-Beam C-Clamps (MSS Type 19): For use under roof installations with bar-joint construction to attach to top flange of structural shape.
 3. Side-Beam or Channel Clamps (MSS Type 20): For attaching to bottom flange of beams, channels, or angles.
 4. Center-Beam Clamps (MSS Type 21): For attaching to center of bottom flange of beams.
 5. Welded Beam Attachments (MSS Type 22): For attaching to bottom of beams if loads are considerable and rod sizes are large.
 6. C-Clamps (MSS Type 23): For structural shapes.
 7. Top-Beam Clamps (MSS Type 25): For top of beams if hanger rod is required tangent to flange edge.
 8. Side-Beam Clamps (MSS Type 27): For bottom of steel I-beams.
 9. Steel-Beam Clamps with Eye Nuts (MSS Type 28): For attaching to bottom of steel I-beams for heavy loads.
 10. Linked-Steel Clamps with Eye Nuts (MSS Type 29): For attaching to bottom of steel I-beams for heavy loads, with link extensions.
 11. Malleable Beam Clamps with Extension Pieces (MSS Type 30): For attaching to structural steel.
 12. Welded-Steel Brackets: For support of pipes from below, or for suspending from above by using clip and rod. Use one of the following for indicated loads:
 - a. Light (MSS Type 31): 750 lb.

- b. Medium (MSS Type 32): 1500 lb.
 - c. Heavy (MSS Type 33): 3000 lb.
13. Side-Beam Brackets (MSS Type 34): For sides of steel or wooden beams.
14. Plate Lugs (MSS Type 57): For attaching to steel beams if flexibility at beam is required.
15. Horizontal Travelers (MSS Type 58): For supporting piping systems subject to linear horizontal movement where headroom is limited.
- J. Saddles and Shields: Unless otherwise indicated and except as specified in piping system Sections, install the following types:
- 1. Steel Pipe-Covering Protection Saddles (MSS Type 39): To fill interior voids with insulation that matches adjoining insulation.
 - 2. Protection Shields (MSS Type 40): Of length recommended in writing by manufacturer to prevent crushing insulation.
 - 3. Thermal-Hanger Shield Inserts: For supporting insulated pipe.
- K. Spring Hangers and Supports: Unless otherwise indicated and except as specified in piping system Sections, install the following types:
- 1. Restraint-Control Devices (MSS Type 47): Where indicated to control piping movement.
 - 2. Spring Cushions (MSS Type 48): For light loads if vertical movement does not exceed 1-1/4 inches.
 - 3. Spring-Cushion Roll Hangers (MSS Type 49): For equipping Type 41 roll hanger with springs.
 - 4. Spring Sway Braces (MSS Type 50): To retard sway, shock, vibration, or thermal expansion in piping systems.
 - 5. Variable-Spring Hangers (MSS Type 51): Preset to indicated load and limit variability factor to 25 percent to absorb expansion and contraction of piping system from hanger.
 - 6. Variable-Spring Base Supports (MSS Type 52): Preset to indicated load and limit variability factor to 25 percent to absorb expansion and contraction of piping system from base support.
 - 7. Variable-Spring Trapeze Hangers (MSS Type 53): Preset to indicated load and limit variability factor to 25 percent to absorb expansion and contraction of piping system from trapeze support.
 - 8. Constant Supports: For critical piping stress and if necessary to avoid transfer of stress from one support to another support, critical terminal, or connected equipment. Include auxiliary stops for erection, hydrostatic test, and load-adjustment capability. These supports include the following types:
 - a. Horizontal (MSS Type 54): Mounted horizontally.
 - b. Vertical (MSS Type 55): Mounted vertically.
 - c. Trapeze (MSS Type 56): Two vertical-type supports and one trapeze member.
- L. Comply with MSS SP-69 for trapeze pipe hanger selections and applications that are not specified in piping system Sections.
- M. Comply with MFMA-102 for metal framing system selections and applications that are not specified in piping system Sections.
- N. Use powder-actuated fasteners or mechanical-expansion anchors instead of building attachments where required in concrete construction.
- O. Use pipe positioning systems in pipe spaces behind plumbing fixtures to support supply and waste piping for plumbing fixtures.

3.2 HANGER AND SUPPORT INSTALLATION

- A. Comply with SEI/ASCE 7 and with requirements for seismic-restraint devices in Section 220548 "Vibration and Seismic Controls for Plumbing Piping and Equipment."
- B. Steel Pipe Hanger Installation: Comply with MSS SP-69 and MSS SP-89. Install hangers, supports, clamps, and attachments as required to properly support piping from building structure.
- C. Trapeze Pipe Hanger Installation: Comply with MSS SP-69 and MSS SP-89. Arrange for grouping of parallel runs of horizontal piping and support together on field-fabricated trapeze pipe hangers.
 - 1. Pipes of Various Sizes: Support together and space trapezes for smallest pipe size or install intermediate supports for smaller diameter pipes as specified above for individual pipe hangers.
 - 2. Field fabricate from ASTM A 36/A 36M, steel shapes selected for loads being supported. Weld steel according to AWS D1.1.
- D. Metal Framing System Installation: Arrange for grouping of parallel runs of piping and support together on field-assembled metal framing systems.
- E. Thermal-Hanger Shield Installation: Install in pipe hanger or shield for insulated piping.
- F. Fastener System Installation:
 - 1. Install powder-actuated fasteners for use in lightweight concrete or concrete slabs less than 4 inches thick in concrete after concrete is placed and completely cured. Use operators that are licensed by powder-actuated tool manufacturer. Install fasteners according to powder-actuated tool manufacturer's operating manual. Powder actuated fasteners shall not be used for seismic bracing attachments.
 - 2. Install mechanical-expansion anchors in concrete after concrete is placed and completely cured. Install fasteners according to manufacturer's written instructions. For anchors resisting seismic loads and/or supporting life-safety systems including fire sprinkler systems, anchors shall have been tested for 'Cracked Concrete' per A.C. 193 and shall have a valid ICC-ES Evaluation Report
- G. Pipe Positioning System Installation: Install support devices to make rigid supply and waste piping connections to each plumbing fixture. Refer to Division 22 Section "Plumbing Fixtures" for plumbing fixtures.
- H. Install hangers and supports complete with necessary inserts, bolts, rods, nuts, washers, and other accessories.
- I. Equipment Support Installation: Fabricate from welded-structural-steel shapes.
- J. Install hangers and supports to allow controlled thermal and seismic movement of piping systems, to permit freedom of movement between pipe anchors, and to facilitate action of expansion joints, expansion loops, expansion bends, and similar units.
- K. Install lateral bracing with pipe hangers and supports to prevent swaying.
- L. Install building attachments within concrete slabs or attach to structural steel. Install additional attachments at concentrated loads, including valves, flanges, and strainers, NPS 2-1/2 and larger and at changes in direction of piping. Install concrete inserts before concrete is placed; fasten inserts to forms and install reinforcing bars through openings at top of inserts.

- M. Load Distribution: Install hangers and supports so piping live and dead loads and stresses from movement will not be transmitted to connected equipment.
- N. Pipe Slopes: Install hangers and supports to provide indicated pipe slopes and so maximum pipe deflections allowed by ASME B31.9 (for building services piping) are not exceeded.
- O. Insulated Piping: Comply with the following:
 - 1. Attach clamps and spacers to piping.
 - a. Piping Operating above Ambient Air Temperature: Clamp may project through insulation.
 - b. Piping Operating below Ambient Air Temperature: Use thermal-hanger shield insert with clamp sized to match OD of insert.
 - c. Do not exceed pipe stress limits according to ASME B31.9 for building services piping.
 - 2. Install MSS SP-58, Type 39, protection saddles if insulation without vapor barrier is indicated. Fill interior voids with insulation that matches adjoining insulation.
 - a. Option: Thermal-hanger shield inserts may be used. Include steel weight-distribution plate for pipe NPS 4 and larger if pipe is installed on rollers.
 - 3. Install MSS SP-58, Type 40, protective shields on cold piping with vapor barrier. Shields shall span an arc of 180 degrees.
 - a. Option: Thermal-hanger shield inserts may be used. Include steel weight-distribution plate for pipe NPS 4 and larger if pipe is installed on rollers.
 - 4. Shield Dimensions for Pipe: Not less than the following:
 - a. NPS 1/4 to NPS 3-1/2: 12 inches long and 0.048 inch thick.
 - b. NPS 4: 12 inches long and 0.06 inch thick.
 - c. NPS 5 and NPS 6: 18 inches long and 0.06 inch thick.
 - d. NPS 8 to NPS 14: 24 inches long and 0.075 inch thick.
 - e. NPS 16 to NPS 24: 24 inches long and 0.105 inch thick.
 - 5. Pipes NPS 8 and Larger: Include wood inserts.
 - 6. Insert Material: Length at least as long as protective shield.
 - 7. Thermal-Hanger Shields: Install with insulation same thickness as piping insulation.

3.3 EQUIPMENT SUPPORTS

- A. Fabricate structural-steel stands to suspend equipment from structure overhead or to support equipment above floor.
- B. Grouting: Place grout under supports for equipment and make smooth bearing surface.
- C. Provide lateral bracing, to prevent swaying, for equipment supports. For applications where seismic bracing is required, 'Cracked Concrete' expansion anchors or concrete screws tested per A.C. 193 must be provided for seismic bracing anchorage where post-installed anchors are required.

3.4 METAL FABRICATIONS

- A. Cut, drill, and fit miscellaneous metal fabrications for trapeze pipe hangers and equipment supports.
- B. Fit exposed connections together to form hairline joints. Field weld connections that cannot be shop welded because of shipping size limitations.
- C. Field Welding: Comply with AWS D1.1 procedures for shielded metal arc welding, appearance and quality of welds, and methods used in correcting welding work, and with the following:
 - 1. Use materials and methods that minimize distortion and develop strength and corrosion resistance of base metals.
 - 2. Obtain fusion without undercut or overlap.
 - 3. Remove welding flux immediately.
 - 4. Finish welds at exposed connections so no roughness shows after finishing and contours of welded surfaces match adjacent contours.

3.5 ADJUSTING

- A. Hanger Adjustments: Adjust hangers to distribute loads equally on attachments and to achieve indicated slope of pipe.
- B. Trim excess length of continuous-thread hanger and support rods to 1-1/2 inches .

3.6 PAINTING

- A. Touch Up: Clean field welds and abraded areas of shop paint. Paint exposed areas immediately after erecting hangers and supports. Use same materials as used for shop painting. Comply with SSPC-PA 1 requirements for touching up field-painted surfaces.
 - 1. Apply paint by brush or spray to provide minimum dry film thickness of 2.0 mils.
- B. Touch Up: Cleaning and touchup painting of field welds, bolted connections, and abraded areas of shop paint on miscellaneous metal are specified in Division 09 painting Sections.
- C. Galvanized Surfaces: Clean welds, bolted connections, and abraded areas and apply galvanizing-repair paint to comply with ASTM A 780.

END OF SECTION 22 0529

THIS PAGE LEFT BLANK INTENTIONALLY

SECTION 22 0548

VIBRATION AND SEISMIC CONTROLS FOR PLUMBING PIPING AND EQUIPMENT

PART 1 - GENERAL

1.1 RELATED DOCUMENTS

- A. Drawings and general provisions of the Contract, including General and Supplementary Conditions and Division 01 Specification Sections, apply to this Section.

1.2 SUMMARY

- A. This Section includes the following restraints and vibration isolation as defined in Section 230548 "Vibration Isolation and Seismic Controls for HVAC" for the following:
 - 1. Plumbing Piping.
 - 2. Plumbing Equipment.

PART 2 - PRODUCTS

2.1 (NOT USED)

PART 3 - EXECUTION

3.1 (NOT USED)

END OF SECTION 22 0548

THIS PAGE LEFT BLANK INTENTIONALLY

SECTION 22 0553

IDENTIFICATION FOR PLUMBING PIPING AND EQUIPMENT

PART 1 - GENERAL

1.1 RELATED DOCUMENTS

- A. Drawings and general provisions of the Contract, including General and Supplementary Conditions and Division 01 Specification Sections, apply to this Section.

1.2 SUMMARY

- A. Section Includes:
 - 1. Equipment labels.
 - 2. Warning signs and labels.
 - 3. Pipe labels.
 - 4. Stencils.
 - 5. Valve tags.
 - 6. Warning tags.
 - 7. Ceiling grid

1.3 SUBMITTALS

- A. Product Data: For each type of product indicated.
- B. Samples: For color, letter style, and graphic representation required for each identification material and device.
- C. Equipment Label Schedule: Include a listing of all equipment to be labeled with the proposed content for each label.
- D. Valve numbering scheme.
- E. Valve Schedules: For each piping system to include in maintenance manuals.

1.4 COORDINATION

- A. Coordinate installation of identifying devices with completion of covering and painting of surfaces where devices are to be applied.
- B. Coordinate installation of identifying devices with locations of access panels and doors.
- C. Install identifying devices before installing acoustical ceilings and similar concealment.

PART 2 - PRODUCTS

2.1 EQUIPMENT LABELS

- A. Plastic Labels for Equipment:

1. Material and Thickness: Multilayer, multicolor, plastic labels for mechanical engraving, 1/16 inch thick, and having predrilled holes for attachment hardware.
 2. Letter Color: White.
 3. Background Color: Blue.
 4. Maximum Temperature: Able to withstand temperatures up to 160 deg F.
 5. Minimum Label Size: Length and width vary for required label content, but not less than 2-1/2 by 3/4 inch.
 6. Minimum Letter Size: 1/4 inch for name of units if viewing distance is less than 24 inches, 1/2 inch for viewing distances up to 72 inches, and proportionately larger lettering for greater viewing distances. Include secondary lettering two-thirds to three-fourths the size of principal lettering.
 7. Fasteners: Stainless-steel rivets or self-tapping screws.
 8. Adhesive: Contact-type permanent adhesive, compatible with label and with substrate.
- B. Label Content: Include equipment's Drawing designation or unique equipment number, Drawing numbers where equipment is indicated (plans, details, and schedules), plus the Specification Section number and title where equipment is specified.
- C. Equipment Label Schedule: For each item of equipment to be labeled, on 8-1/2-by-11-inch bond paper. Tabulate equipment identification number and identify Drawing numbers where equipment is indicated (plans, details, and schedules), plus the Specification Section number and title where equipment is specified. Equipment schedule shall be included in operation and maintenance data.

2.2 WARNING SIGNS AND LABELS

- A. Material and Thickness: Multilayer, multicolor, plastic labels for mechanical engraving, 1/16 inch thick, and having predrilled holes for attachment hardware.
- B. Letter Color: Black.
- C. Background Color: Yellow.
- D. Maximum Temperature: Able to withstand temperatures up to 160 deg F.
- E. Minimum Label Size: Length and width vary for required label content, but not less than 2-1/2 by 3/4 inch.
- F. Minimum Letter Size: 1/4 inch for name of units if viewing distance is less than 24 inches, 1/2 inch for viewing distances up to 72 inches, and proportionately larger lettering for greater viewing distances. Include secondary lettering two-thirds to three-fourths the size of principal lettering.
- G. Fasteners: Stainless-steel rivets or self-tapping screws.
- H. Adhesive: Contact-type permanent adhesive, compatible with label and with substrate.
- I. Label Content: Include caution and warning information, plus emergency notification instructions.

2.3 PIPE LABELS

- A. General Requirements for Manufactured Pipe Labels: Preprinted, color-coded, with lettering indicating service, and showing flow direction.

- B. Pretensioned Pipe Labels: Precoiled, semirigid plastic formed to cover full circumference of pipe and to attach to pipe without fasteners or adhesive.
- C. Self-Adhesive Pipe Labels: Printed plastic with contact-type, permanent-adhesive backing.
- D. Pipe Label Contents: Include identification of piping service using same designations or abbreviations as used on Drawings, pipe size, and an arrow indicating flow direction.
 - 1. Flow-Direction Arrows: Integral with piping system service lettering to accommodate both directions, or as separate unit on each pipe label to indicate flow direction.
 - 2. Lettering Size: At least 1-1/2 inches high.

2.4 STENCILS

- A. Stencils: Prepared with letter sizes according to ASME A13.1 for piping; and minimum letter height of 3/4 inch for access panel and door labels, equipment labels, and similar operational instructions.
 - 1. Stencil Material: Fiberboard or metal.
 - 2. Stencil Paint: Exterior, gloss, alkyd enamel black unless otherwise indicated. Paint may be in pressurized spray-can form.
 - 3. Identification Paint: Exterior, alkyd enamel in colors according to ASME A13.1 unless otherwise indicated.

2.5 VALVE TAGS

- A. Valve Tags: Stamped or engraved with 1/4-inch letters for piping system abbreviation and 1/2-inch numbers.
 - 1. Tag Material: Brass, 0.032-inch minimum thickness, and having predrilled or stamped holes for attachment hardware.
 - 2. Fasteners: Brass wire-link or beaded chain; or S-hook.
- B. Valve Schedules: For each piping system, on 8-1/2-by-11-inch bond paper. Tabulate valve number, piping system, system abbreviation (as shown on valve tag), location of valve (room or space), normal-operating position (open, closed, or modulating), and variations for identification. Mark valves for emergency shutoff and similar special uses.
 - 1. Valve-tag schedule shall be included in operation and maintenance data.

2.6 WARNING TAGS

- A. Warning Tags: Preprinted or partially preprinted, accident-prevention tags, of plasticized card stock with matte finish suitable for writing.
 - 1. Size: 3 by 5-1/4 inches minimum.
 - 2. Fasteners: Brass grommet and wire.
 - 3. Nomenclature: Large-size primary caption such as "DANGER," "CAUTION," or "DO NOT OPERATE."
 - 4. Color: Yellow background with black lettering.

2.7 CEILING GRID

- A. Provide valve identification for all plumbing and med gas valves located above the ceiling on the ceiling grid below the valve.

PART 3 - EXECUTION

3.1 PREPARATION

- A. Clean piping and equipment surfaces of substances that could impair bond of identification devices, including dirt, oil, grease, release agents, and incompatible primers, paints, and encapsulants.

3.2 EQUIPMENT LABEL INSTALLATION

- A. Install or permanently fasten labels on each major item of mechanical equipment.
- B. Locate equipment labels where accessible and visible.

3.3 PIPE LABEL INSTALLATION

- A. Piping Color-Coding: Painting of piping is specified in Division 09.
- B. Stenciled Pipe Label Option: Stenciled labels may be provided instead of manufactured pipe labels, at Installer's option. Install stenciled pipe labels, complying with ASME A13.1, on each piping system.
 - 1. Identification Paint: Use for contrasting background.
 - 2. Stencil Paint: Use for pipe marking.
- C. Locate pipe labels where piping is exposed or above accessible ceilings in finished spaces; machine rooms; accessible maintenance spaces such as shafts, tunnels, and plenums; and exterior exposed locations as follows:
 - 1. Near each valve and control device.
 - 2. Near each branch connection, excluding short takeoffs for fixtures and terminal units. Where flow pattern is not obvious, mark each pipe at branch.
 - 3. Near penetrations through walls, floors, ceilings, and inaccessible enclosures.
 - 4. At access doors, manholes, and similar access points that permit view of concealed piping.
 - 5. Near major equipment items and other points of origination and termination.
 - 6. Spaced at maximum intervals of 25 feet along each main run. Branch piping & piping in congested areas are to have labels spaced at maximum intervals of 6 feet.
 - 7. On piping above removable acoustical ceilings. Omit intermediately spaced labels.
 - 8. On hard lid ceilings where piping enters and exits the room.
- D. Pipe Label Color Schedule:
 - 1. Low-Pressure, Compressed-Air Piping:
 - a. Background Color: Comply with ASME A13.1.
 - b. Letter Color: Comply with ASME A13.1.
 - 2. Medium-Pressure, Compressed-Air Piping:

- a. Background Color: Comply with ASME A13.1.
 - b. Letter Color: Comply with ASME A13.1.
3. Domestic Water Piping:
- a. Background Color: Comply with ASME A13.1.
 - b. Letter Color: Comply with ASME A13.1.
4. Sanitary Waste and Storm Drainage Piping:
- a. Background Color: Comply with ASME A13.1.
 - b. Letter Color: Comply with ASME A13.1.

3.4 VALVE-TAG INSTALLATION

- A. Install tags on valves and control devices in piping systems, except check valves; valves within factory-fabricated equipment units; shutoff valves; faucets; convenience and lawn-watering hose connections; and similar roughing-in connections of end-use fixtures and units. List tagged valves in a valve schedule.
- B. Valve-Tag Application Schedule: Tag valves according to size, shape, and color scheme and with captions similar to those indicated in the following subparagraphs:
- 1. Valve-Tag Size and Shape:
 - a. Cold Water: 1-1/2 inches, round.
 - b. Hot Water: 1-1/2 inches, round.
 - c. Low-Pressure Compressed Air: 1-1/2 inches, round.
 - d. High-Pressure Compressed Air: 1-1/2 inches, round.
 - 2. Valve-Tag Color:
 - a. Cold Water: Comply with ASME A13.1.
 - b. Hot Water: Comply with ASME A13.1.
 - c. Low-Pressure Compressed Air: Comply with ASME A13.1.
 - d. High-Pressure Compressed Air: Comply with ASME A13.1.
 - 3. Letter Color:
 - a. Cold Water: Comply with ASME A13.1.
 - b. Hot Water: Comply with ASME A13.1.
 - c. Low-Pressure Compressed Air: Comply with ASME A13.1.
 - d. High-Pressure Compressed Air: Comply with ASME A13.1.

3.5 WARNING-TAG INSTALLATION

- A. Write required message on, and attach warning tags to, equipment and other items where required.

END OF SECTION 22 0553

THIS PAGE LEFT BLANK INTENTIONALLY

SECTION 22 0719

PLUMBING PIPING INSULATION

PART 1 - GENERAL

1.1 RELATED DOCUMENTS

- A. Drawings and general provisions of the Contract, including General and Supplementary Conditions and Division 01 Specification Sections, apply to this Section.

1.2 SUMMARY

- A. Section includes insulating the following plumbing piping services:
 - 1. Domestic cold-water piping.
 - 2. Domestic hot-water piping.
 - 3. Domestic recirculating hot-water piping.
 - 4. Roof drains and rainwater leaders.
 - 5. Supplies and drains for handicap-accessible lavatories and sinks 3.1

1.3 DEFINITIONS:

- A. Refer to Section 220500 "Common Work Results for Plumbing".

1.4 ACTION SUBMITTALS

- A. Product Data: For each type of product indicated. Include thermal conductivity, water-vapor permeance thickness, and jackets (both factory- and field-applied, if any).
- B. LEED Submittals:
 - 1. Product Data for Credit IEQ 4.1: For adhesives and sealants, documentation including printed statement of VOC content and chemical components.
 - 2. Laboratory Test Reports for Credit IEQ 4: For adhesives and sealants, documentation indicating that product complies with the testing and product requirements of the California Department of Health Services' "Standard Practice for the Testing of Volatile Organic Emissions from Various Sources Using Small-Scale Environmental Chambers."
- C. Shop Drawings: Include plans, elevations, sections, details, and attachments to other work.
 - 1. Detail application of protective shields, saddles, and inserts at hangers for each type of insulation and hanger.
 - 2. Detail attachment and covering of heat tracing inside insulation.
 - 3. Detail insulation application at pipe expansion joints for each type of insulation.
 - 4. Detail insulation application at elbows, fittings, flanges, valves, and specialties for each type of insulation.
 - 5. Detail removable insulation at piping specialties, equipment connections, and access panels.
 - 6. Detail application of field-applied jackets.
 - 7. Detail application at linkages of control devices.

1.5 INFORMATIONAL SUBMITTALS

- A. Qualification Data: For qualified Installer.
- B. Material Test Reports: From a qualified testing agency acceptable to authorities having jurisdiction indicating, interpreting, and certifying test results for compliance of insulation materials, sealers, attachments, cements, and jackets, with requirements indicated. Include dates of tests and test methods employed.

1.6 QUALITY ASSURANCE

- A. Installer Qualifications: Skilled mechanics who have successfully completed an apprenticeship program or another craft training program certified by the Department of Labor, Bureau of Apprenticeship and Training.
- B. Surface-Burning Characteristics: For insulation and related materials, as determined by testing identical products according to ASTM E 84 by a testing agency acceptable to authorities having jurisdiction. Factory label insulation and jacket materials and adhesive, mastic, tapes, and cement material containers, with appropriate markings of applicable testing agency.
 - 1. Insulation Installed Indoors: Flame-spread index of 25 or less, and smoke-developed index of 50 or less.
 - 2. Insulation Installed Outdoors: Flame-spread index of 75 or less, and smoke-developed index of 150 or less.

1.7 DELIVERY, STORAGE, AND HANDLING

- A. Packaging: Insulation material containers shall be marked by manufacturer with appropriate ASTM standard designation, type and grade, and maximum use temperature.

1.8 COORDINATION

- A. Coordinate sizes and locations of supports, hangers, and insulation shields specified in Section 220529 "Hangers and Supports for Plumbing Piping and Equipment."
- B. Coordinate clearance requirements with piping Installer for piping insulation application. Before preparing piping Shop Drawings establish and maintain clearance requirements for installation of insulation and field-applied jackets and finishes and for space required for maintenance.
- C. Coordinate installation and testing of heat tracing.

1.9 SCHEDULING

- A. Schedule insulation application after pressure testing systems and, where required, after installing and testing heat tracing. Insulation application may begin on segments that have satisfactory test results.
- B. Complete installation and concealment of plastic materials as rapidly as possible in each area of construction.

PART 2 - PRODUCTS

2.1 INSULATION MATERIALS

- A. Comply with requirements in "Piping Insulation Schedule, General," "Indoor Piping Insulation Schedule," "Outdoor, Aboveground Piping Insulation Schedule," and "Outdoor, Underground Piping Insulation Schedule" articles for where insulating materials shall be applied.
- B. Insulation for below-ambient service requires a vapor-barrier.
- C. Products shall not contain asbestos, lead, mercury, or mercury compounds.
- D. Products that come in contact with stainless steel shall have a leachable chloride content of less than 50 ppm when tested according to ASTM C 871.
- E. Insulation materials for use on austenitic stainless steel shall be qualified as acceptable according to ASTM C 795.
- F. Foam insulation materials shall not use CFC or HCFC blowing agents in the manufacturing process.
- G. Flexible Elastomeric Insulation: Closed-cell, sponge- or expanded-rubber materials. Comply with ASTM C 534, Type I for tubular materials.
 - 1. Products: Subject to compliance with requirements, provide one of the following:
 - a. Aeroflex USA, Inc.; Aerocel.
 - b. Armacell LLC; AP Armaflex.
 - c. K-Flex USA; Insul-Lock, Insul-Tube, and K-FLEX LS.
- H. Mineral-Fiber Blanket Insulation: Mineral or glass fibers bonded with a thermosetting resin. Comply with ASTM C 553:
 - 1. Type II and ASTM C 1290, Factory-applied jacket requirements are specified in "Factory-Applied Jackets" Article.
 - 2. Products: Subject to compliance with requirements, provide one of the following:
 - a. CertainTeed Corp.; SoftTouch Duct Wrap.
 - b. Johns Manville; Microlite.
 - c. Knauf Insulation; Friendly Feel Duct Wrap.
 - d. Manson Insulation Inc.; Alley Wrap.
 - e. Owens Corning; SOFTR All-Service Duct Wrap.
- I. Mineral-Fiber, Preformed Pipe Insulation:
 - 1. Products: Subject to compliance with requirements, provide one of the following:
 - a. Fibrex Insulations Inc.; Coreplus 1200.
 - b. Johns Manville; Micro-Lok.
 - c. Knauf Insulation; 1000-Degree Pipe Insulation.
 - d. Manson Insulation Inc.; Alley-K.
 - e. Owens Corning; Fiberglas Pipe Insulation.
 - 2. Type I, 850 Deg F Materials: Mineral or glass fibers bonded with a thermosetting resin. Comply with ASTM C 547, Type I, Grade A,
 - a. Without factory-applied jacket with factory-applied ASJ-SSL. Factory-applied jacket requirements are specified in "Factory-Applied Jackets" Article.

- J. Prefabricated Thermal Insulating Fitting Covers: Comply with ASTM C 450 for dimensions used in preforming insulation to cover valves, elbows, tees, and flanges.

2.2 INSULATING CEMENTS

- A. Mineral-Fiber Insulating Cement: Comply with ASTM C 195.
 - 1. Products: Subject to compliance with requirements, provide the following:
 - a. Ramco Insulation, Inc.; Super-Stik.
- B. Mineral-Fiber, Hydraulic-Setting Insulating and Finishing Cement: Comply with ASTM C 449.
 - 1. Products: Subject to compliance with requirements, provide the following:
 - a. Ramco Insulation, Inc.; Ramcote 1200 and Quik-Cote.

2.3 ADHESIVES

- A. Materials shall be compatible with insulation materials, jackets, and substrates and for bonding insulation to itself and to surfaces to be insulated, unless otherwise indicated.
- B. Flexible Elastomeric Adhesive: Comply with MIL-A-24179A, Type II, Class I.
 - 1. Products: Subject to compliance with requirements, provide one of the following:
 - a. Aeroflex USA, Inc.; Aero seal.
 - b. Armacell LLC; Armaflex 520 Adhesive.
 - c. Foster Brand, Specialty Construction Brands, Inc., a business of H. B. Fuller Company; 85-75.
 - d. K-Flex USA; R-373 Contact Adhesive.
 - 2. For indoor applications, adhesive shall have a VOC content of 50 g/L or less when calculated according to 40 CFR 59, Subpart D (EPA Method 24).
- C. Mineral-Fiber Adhesive: Comply with MIL-A-3316C, Class 2, Grade A.
 - 1. Products: Subject to compliance with requirements, provide one of the following:
 - a. Childers Brand, Specialty Construction Brands, Inc., a business of H. B. Fuller Company; CP-127.
 - b. Eagle Bridges - Marathon Industries; 225.
 - c. Foster Brand, Specialty Construction Brands, Inc., a business of H. B. Fuller Company; 85-60/85-70.
 - d. Mon-Eco Industries, Inc.; 22-25.
 - 2. For indoor applications, adhesive shall have a VOC content of 80 g/L or less when calculated according to 40 CFR 59, Subpart D (EPA Method 24).
- D. ASJ Adhesive, and FSK Jacket Adhesive: Comply with MIL-A-3316C, Class 2, Grade A for bonding insulation jacket lap seams and joints.
 - 1. Products: Subject to compliance with requirements, provide one of the following:
 - a. Childers Brand, Specialty Construction Brands, Inc., a business of H. B. Fuller Company; CP-82.
 - b. Eagle Bridges - Marathon Industries; 225.

- c. Foster Brand, Specialty Construction Brands, Inc., a business of H. B. Fuller Company; 85-20.
 - d. Mon-Eco Industries, Inc.; 22-25.
 - 2. For indoor applications, adhesive shall have a VOC content of 50 g/L or less when calculated according to 40 CFR 59, Subpart D (EPA Method 24).
- E. PVC Jacket Adhesive: Compatible with PVC jacket.
- 1. Products: Subject to compliance with requirements, provide one of the following:
 - a. Dow Corning Corporation; 739, Dow Silicone.
 - b. Johns Manville; Zeston Perma-Weld, CEEL-TITE Solvent Welding Adhesive.
 - c. P.I.C. Plastics, Inc.; Welding Adhesive.
 - d. Speedline Corporation; Polyco VP Adhesive.
 - 2. For indoor applications, adhesive shall have a VOC content of 50 g/L or less when calculated according to 40 CFR 59, Subpart D (EPA Method 24).

2.4 MASTICS

- A. Materials shall be compatible with insulation materials, jackets, and substrates; comply with MIL-PRF-19565C, Type II.
- 1. For indoor applications, use mastics that have a VOC content of 50 g/L or less when calculated according to 40 CFR 59, Subpart D (EPA Method 24).
- B. Vapor-Barrier Mastic: Water based; suitable for indoor use on below-ambient services.
- 1. Products: Subject to compliance with requirements, provide one of the following:
 - a. Foster Brand, Specialty Construction Brands, Inc., a business of H. B. Fuller Company; 30-80/30-90.
 - b. Vimasco Corporation; 749.
 - 2. Water-Vapor Permeance: ASTM E 96/E 96M, Procedure B, 0.013 perm at 43-mil dry film thickness.
 - 3. Service Temperature Range: Minus 20 to plus 180 deg F .
 - 4. Solids Content: ASTM D 1644, 58 percent by volume and 70 percent by weight.
 - 5. Color: White.
- C. Vapor-Barrier Mastic: Solvent based; suitable for indoor use on below-ambient services.
- 1. Products: Subject to compliance with requirements, provide one of the following:
 - a. Childers Brand, Specialty Construction Brands, Inc., a business of H. B. Fuller Company; CP-30.
 - b. Eagle Bridges - Marathon Industries; 501.
 - c. Foster Brand, Specialty Construction Brands, Inc., a business of H. B. Fuller Company; 30-35.
 - d. Mon-Eco Industries, Inc.; 55-10.
 - 2. Water-Vapor Permeance: ASTM F 1249, 0.05 perm at 35-mil dry film thickness.
 - 3. Service Temperature Range: 0 to 180 deg F.
 - 4. Solids Content: ASTM D 1644, 44 percent by volume and 62 percent by weight.
 - 5. Color: White.
- D. Vapor-Barrier Mastic: Solvent based; suitable for outdoor use on below-ambient services.

1. Products: Subject to compliance with requirements, provide one of the following:
 - a. Childers Brand, Specialty Construction Brands, Inc., a business of H. B. Fuller Company; Encacel.
 - b. Eagle Bridges - Marathon Industries; 570.
 - c. Foster Brand, Specialty Construction Brands, Inc., a business of H. B. Fuller Company; 60-95/60-96.
 2. Water-Vapor Permeance: ASTM F 1249, 0.05 perm at 30-mil dry film thickness.
 3. Service Temperature Range: Minus 50 to plus 220 deg F .
 4. Solids Content: ASTM D 1644, 33 percent by volume and 46 percent by weight.
 5. Color: White.
- E. Breather Mastic: Water based; suitable for indoor and outdoor use on above-ambient services.
1. Products: Subject to compliance with requirements, provide one of the following:
 - a. Childers Brand, Specialty Construction Brands, Inc., a business of H. B. Fuller Company; CP-10.
 - b. Eagle Bridges - Marathon Industries; 550.
 - c. Foster Brand, Specialty Construction Brands, Inc., a business of H. B. Fuller Company; 46-50.
 - d. Mon-Eco Industries, Inc.; 55-50.
 - e. Vimasco Corporation; WC-1/WC-5.
 2. Water-Vapor Permeance: ASTM F 1249, 1.8 perms at 0.0625-inch dry film thickness.
 3. Service Temperature Range: Minus 20 to plus 180 deg F .
 4. Solids Content: 60 percent by volume and 66 percent by weight.
 5. Color: White.

2.5 SEALANTS

- A. ASJ Flashing Sealants and PVC Jacket Flashing Sealants:
1. Products: Subject to compliance with requirements, provide the following:
 - a. Childers Brand, Specialty Construction Brands, Inc., a business of H. B. Fuller Company; CP-76.
 2. Materials shall be compatible with insulation materials, jackets, and substrates.
 3. Fire- and water-resistant, flexible, elastomeric sealant.
 4. Service Temperature Range: Minus 40 to plus 250 deg F .
 5. Color: White.
 6. For indoor applications, sealants shall have a VOC content of 420 g/L or less when calculated according to 40 CFR 59, Subpart D (EPA Method 24).

2.6 FACTORY-APPLIED JACKETS

- A. Insulation system schedules indicate factory-applied jackets on various applications. When factory-applied jackets are indicated, comply with the following:
1. ASJ-SSL: ASJ with self-sealing, pressure-sensitive, acrylic-based adhesive covered by a removable protective strip; complying with ASTM C 1136, Type I.

2.7 FIELD-APPLIED JACKETS

- A. Field-applied jackets shall comply with ASTM C 921, Type I, unless otherwise indicated.

- B. PVC Jacket: High-impact-resistant, UV-resistant PVC complying with ASTM D 1784, Class 16354-C; thickness as scheduled; roll stock ready for shop or field cutting and forming. Thickness is indicated in field-applied jacket schedules.
1. Products: Subject to compliance with requirements, provide one of the following:
 - a. Johns Manville; Zeston.
 - b. P.I.C. Plastics, Inc.; FG Series.
 - c. Proto Corporation; LoSmoke.
 - d. Speedline Corporation; SmokeSafe.
 2. Adhesive: As recommended by jacket material manufacturer.
 3. Color: PVC, white; 30 mils thick..
 4. Factory-fabricated fitting covers to match jacket if available; otherwise, field fabricate.
 - a. Shapes: 45- and 90-degree, short- and long-radius elbows, tees, valves, flanges, unions, reducers, end caps, soil-pipe hubs, traps, mechanical joints, and P-trap and supply covers for lavatories.

C. Metal Jacket:

1. Products: Subject to compliance with requirements, provide one of the following:
 - a. Childers Brand, Specialty Construction Brands, Inc., a business of H. B. Fuller Company; Metal Jacketing Systems.
 - b. ITW Insulation Systems; Aluminum and Stainless Steel Jacketing.
 - c. RPR Products, Inc.; Insul-Mate.
2. Aluminum Jacket: Comply with ASTM B 209 (ASTM B 209M), Alloy 3003, 3005, 3105, or 5005, Temper H-14.
 - a. Sheet and roll stock ready for shop or field sizing or factory cut and rolled to size.
 - b. Finish and thickness are indicated in field-applied jacket schedules.
 - c. Moisture Barrier for Indoor Applications: 1-mil- thick, heat-bonded polyethylene and kraft paper. 3-mil- thick, heat-bonded polyethylene and kraft paper.
 - d. Moisture Barrier for Outdoor Applications: 3-mil- thick, heat-bonded polyethylene and kraft paper.
 - e. Factory-Fabricated Fitting Covers:
 - 1) Same material, finish, and thickness as jacket.
 - 2) Preformed 2-piece or gore, 45- and 90-degree, short- and long-radius elbows.
 - 3) Tee covers.
 - 4) Flange and union covers.
 - 5) End caps.
 - 6) Beveled collars.
 - 7) Valve covers.
 - 8) Field fabricate fitting covers only if factory-fabricated fitting covers are not available.

2.8 TAPES

- A. ASJ Tape: White vapor-retarder tape matching factory-applied jacket with acrylic adhesive, complying with ASTM C 1136.
1. Products: Subject to compliance with requirements, provide one of the following:
 - a. ABI, Ideal Tape Division; 428 AWF ASJ.

- b. Avery Dennison Corporation, Specialty Tapes Division; Fasson 0836.
 - c. Compac Corporation; 104 and 105.
 - d. Venture Tape; 1540 CW Plus, 1542 CW Plus, and 1542 CW Plus/SQ.
 - 2. Width: 3 inches.
 - 3. Thickness: 11.5 mils.
 - 4. Adhesion: 90 ounces force/inch in width.
 - 5. Elongation: 2 percent.
 - 6. Tensile Strength: 40 lbf/inch in width.
 - 7. ASJ Tape Disks and Squares: Precut disks or squares of ASJ tape.
- B. PVC Tape: White vapor-retarder tape matching field-applied PVC jacket with acrylic adhesive; suitable for indoor and outdoor applications.
- 1. Products: Subject to compliance with requirements, provide one of the following:
 - a. ABI, Ideal Tape Division; 370 White PVC tape.
 - b. Compac Corporation; 130.
 - c. Venture Tape; 1506 CW NS.
 - 2. Width: 2 inches.
 - 3. Thickness: 6 mils.
 - 4. Adhesion: 64 ounces force/inch in width.
 - 5. Elongation: 500 percent.
 - 6. Tensile Strength: 18 lbf/inch in width.
- C. Aluminum-Foil Tape: Vapor-retarder tape with acrylic adhesive.
- 1. Products: Subject to compliance with requirements, provide one of the following:
 - a. ABI, Ideal Tape Division; 488 AWF.
 - b. Avery Dennison Corporation, Specialty Tapes Division; Fasson 0800.
 - c. Compac Corporation; 120.
 - d. Venture Tape; 3520 CW.
 - 2. Width: 2 inches.
 - 3. Thickness: 3.7 mils.
 - 4. Adhesion: 100 ounces force/inch in width.
 - 5. Elongation: 5 percent.
 - 6. Tensile Strength: 34 lbf/inch in width.

2.9 SECUREMENTS

- A. Staples: Outward-clinching insulation staples, nominal 3/4-inch- wide, stainless steel or Monel.

2.10 PROTECTIVE SHIELDING GUARDS

- A. Protective Shielding Pipe Covers:

- 1. Manufacturers: Subject to compliance with requirements provide products by one of the following:
 - a. Engineered Brass Company.
 - b. Insul-Tect Products Co.; a subsidiary of MVG Molded Products.
 - c. McGuire Manufacturing.
 - d. Plumberex.
 - e. Truebro; a brand of IPS Corporation.
 - f. Zurn Industries, LLC; Tubular Brass Plumbing Products Operation.

2. Description: Manufactured plastic wraps for covering plumbing fixture hot- and cold-water supplies and trap and drain piping. Comply with Americans with Disabilities Act (ADA) requirements.
- B. Protective Shielding Piping Enclosures:
1. Manufacturers: Subject to compliance with requirements provide products by one of the following:
 - a. Truebro; a brand of IPS Corporation.
 - b. Zurn Industries, LLC; Tubular Brass Plumbing Products Operation.
 2. Description: Manufactured plastic enclosure for covering plumbing fixture hot- and cold-water supplies and trap and drain piping. Comply with ADA requirements.

PART 3 - EXECUTION

3.1 EXAMINATION

- A. Examine substrates and conditions for compliance with requirements for installation tolerances and other conditions affecting performance of insulation application.
 1. Verify that systems to be insulated have been tested and are free of defects.
 2. Verify that surfaces to be insulated are clean and dry.
- B. Proceed with installation only after unsatisfactory conditions have been corrected.

3.2 PREPARATION

- A. Surface Preparation: Clean and dry surfaces to receive insulation. Remove materials that will adversely affect insulation application.
- B. Coordinate insulation installation with the trade installing heat tracing. Comply with requirements for heat tracing that apply to insulation.
- C. Mix insulating cements with clean potable water; if insulating cements are to be in contact with stainless-steel surfaces, use demineralized water.

3.3 GENERAL INSTALLATION REQUIREMENTS

- A. Install insulation materials, accessories, and finishes with smooth, straight, and even surfaces; free of voids throughout the length of piping including fittings, valves, and specialties.
- B. Install insulation materials, forms, vapor barriers or retarders, jackets, and thicknesses required for each item of pipe system as specified in insulation system schedules.
- C. Install accessories compatible with insulation materials and suitable for the service. Install accessories that do not corrode, soften, or otherwise attack insulation or jacket in either wet or dry state.
- D. Install insulation with longitudinal seams at top and bottom of horizontal runs.
- E. Install multiple layers of insulation with longitudinal and end seams staggered.
- F. Do not weld brackets, clips, or other attachment devices to piping, fittings, and specialties.

- G. Keep insulation materials dry during application and finishing.
- H. Install insulation with tight longitudinal seams and end joints. Bond seams and joints with adhesive recommended by insulation material manufacturer.
- I. Install insulation with least number of joints practical.
- J. Where vapor barrier is indicated, seal joints, seams, and penetrations in insulation at hangers, supports, anchors, and other projections with vapor-barrier mastic.
 - 1. Install insulation continuously through hangers and around anchor attachments.
 - 2. For insulation application where vapor barriers are indicated, extend insulation on anchor legs from point of attachment to supported item to point of attachment to structure. Taper and seal ends at attachment to structure with vapor-barrier mastic.
 - 3. Install insert materials and install insulation to tightly join the insert. Seal insulation to insulation inserts with adhesive or sealing compound recommended by insulation material manufacturer.
 - 4. Cover inserts with jacket material matching adjacent pipe insulation. Install shields over jacket, arranged to protect jacket from tear or puncture by hanger, support, and shield.
- K. Apply adhesives, mastics, and sealants at manufacturer's recommended coverage rate and wet and dry film thicknesses.
- L. Install insulation with factory-applied jackets as follows:
 - 1. Draw jacket tight and smooth.
 - 2. Cover circumferential joints with 3-inch wide strips, of same material as insulation jacket. Secure strips with adhesive and outward clinching staples along both edges of strip, spaced 4 inches o.c.
 - 3. Overlap jacket longitudinal seams at least 1-1/2 inches. Install insulation with longitudinal seams at bottom of pipe. Clean and dry surface to receive self-sealing lap. Staple laps with outward clinching staples along edge at:
 - a. 2 inches o.c.
 - b. For below-ambient services, apply vapor-barrier mastic over staples.
 - 4. Cover joints and seams with tape, according to insulation material manufacturer's written instructions, to maintain vapor seal.
 - 5. Where vapor barriers are indicated, apply vapor-barrier mastic on seams and joints and at ends adjacent to pipe flanges and fittings.
- M. Cut insulation in a manner to avoid compressing insulation more than 75 percent of its nominal thickness.
- N. Finish installation with systems at operating conditions. Repair joint separations and cracking due to thermal movement.
- O. Repair damaged insulation facings by applying same facing material over damaged areas. Extend patches at least 4 inches beyond damaged areas. Adhere, staple, and seal patches similar to butt joints.
- P. For above-ambient services, do not install insulation to the following:
 - 1. Vibration-control devices.
 - 2. Testing agency labels and stamps.
 - 3. Nameplates and data plates.
 - 4. Cleanouts.

3.4 PENETRATIONS

- A. Insulation Installation at Roof Penetrations: Install insulation continuously through roof penetrations.
 - 1. Seal penetrations with flashing sealant.
 - 2. For applications requiring only indoor insulation, terminate insulation above roof surface and seal with joint sealant. For applications requiring indoor and outdoor insulation, install insulation for outdoor applications tightly joined to indoor insulation ends. Seal joint with joint sealant.
 - 3. Extend jacket of outdoor insulation outside roof flashing at least 2 inches below top of roof flashing.
 - 4. Seal jacket to roof flashing with flashing sealant.
- B. Insulation Installation at Underground Exterior Wall Penetrations: Terminate insulation flush with sleeve seal. Seal terminations with flashing sealant.
- C. Insulation Installation at Aboveground Exterior Wall Penetrations: Install insulation continuously through wall penetrations.
 - 1. Seal penetrations with flashing sealant.
 - 2. For applications requiring only indoor insulation, terminate insulation inside wall surface and seal with joint sealant. For applications requiring indoor and outdoor insulation, install insulation for outdoor applications tightly joined to indoor insulation ends. Seal joint with joint sealant.
 - 3. Extend jacket of outdoor insulation outside wall flashing and overlap wall flashing at least 2 inches.
 - 4. Seal jacket to wall flashing with flashing sealant.
- D. Insulation Installation at Interior Wall and Partition Penetrations (That Are Not Fire Rated): Install insulation continuously through walls and partitions.
- E. Insulation Installation at Fire-Rated Wall and Partition Penetrations: Install insulation continuously through penetrations of fire-rated walls and partitions.
 - 1. Comply with requirements in Section 078413 "Penetration Firestopping" for firestopping and fire-resistive joint sealers.
- F. Insulation Installation at Floor Penetrations:
 - 1. Pipe: Install insulation continuously through floor penetrations.
 - 2. Seal penetrations through fire-rated assemblies. Comply with requirements in Section 078413 "Penetration Firestopping."

3.5 GENERAL PIPE INSULATION INSTALLATION

- A. Requirements in this article generally apply to all insulation materials except where more specific requirements are specified in various pipe insulation material installation articles.
- B. Insulation Installation on Fittings, Valves, Strainers, Flanges, and Unions:
 - 1. Install insulation over fittings, valves, strainers, flanges, unions, and other specialties with continuous thermal and vapor-retarder integrity unless otherwise indicated.
 - 2. Insulate pipe elbows using preformed fitting insulation or mitered fittings made from same material and density as adjacent pipe insulation. Each piece shall be butted tightly against adjoining piece and bonded with adhesive. Fill joints, seams, voids, and irregular surfaces with insulating cement finished to a smooth, hard, and uniform contour that is uniform with adjoining pipe insulation.

3. Insulate tee fittings with preformed fitting insulation or sectional pipe insulation of same material and thickness as used for adjacent pipe. Cut sectional pipe insulation to fit. Butt each section closely to the next and hold in place with tie wire. Bond pieces with adhesive.
 4. Insulate valves using preformed fitting insulation or sectional pipe insulation of same material, density, and thickness as used for adjacent pipe. Overlap adjoining pipe insulation by not less than two times the thickness of pipe insulation, or one pipe diameter, whichever is thicker. For valves, insulate up to and including the bonnets, valve stuffing-box studs, bolts, and nuts. Fill joints, seams, and irregular surfaces with insulating cement.
 5. Insulate strainers using preformed fitting insulation or sectional pipe insulation of same material, density, and thickness as used for adjacent pipe. Overlap adjoining pipe insulation by not less than two times the thickness of pipe insulation, or one pipe diameter, whichever is thicker. Fill joints, seams, and irregular surfaces with insulating cement. Insulate strainers so strainer basket flange or plug can be easily removed and replaced without damaging the insulation and jacket. Provide a removable reusable insulation cover. For below-ambient services, provide a design that maintains vapor barrier.
 6. Insulate flanges and unions using a section of oversized preformed pipe insulation. Overlap adjoining pipe insulation by not less than two times the thickness of pipe insulation, or one pipe diameter, whichever is thicker.
 7. Cover segmented insulated surfaces with a layer of finishing cement and coat with a mastic. Install vapor-barrier mastic for below-ambient services and a breather mastic for above-ambient services. Reinforce the mastic with fabric-reinforcing mesh. Trowel the mastic to a smooth and well-shaped contour.
 8. For services not specified to receive a field-applied jacket except for flexible install fitted PVC cover over elbows, tees, strainers, valves, flanges, and unions. Terminate ends with PVC end caps. Tape PVC covers to adjoining insulation facing using PVC tape.
 9. Stencil or label the outside insulation jacket of each union with the word "union." Match size and color of pipe labels.
- C. Insulate instrument connections for thermometers, pressure gages, pressure temperature taps, test connections, flow meters, sensors, switches, and transmitters on insulated pipes. Shape insulation at these connections by tapering it to and around the connection with insulating cement and finish with finishing cement, mastic, and flashing sealant.
- D. Install removable insulation covers at locations indicated. Installation shall conform to the following:
1. Make removable flange and union insulation from sectional pipe insulation of same thickness as that on adjoining pipe. Install same insulation jacket as adjoining pipe insulation.
 2. When flange and union covers are made from sectional pipe insulation, extend insulation from flanges or union long at least two times the insulation thickness over adjacent pipe insulation on each side of flange or union. Secure flange cover in place with stainless-steel or aluminum bands. Select band material compatible with insulation and jacket.
 3. Construct removable valve insulation covers in same manner as for flanges, except divide the two-part section on the vertical center line of valve body.
 4. When covers are made from block insulation, make two halves, each consisting of mitered blocks wired to stainless-steel fabric. Secure this wire frame, with its attached insulation, to flanges with tie wire. Extend insulation at least 2 inches over adjacent pipe insulation on each side of valve. Fill space between flange or union cover and pipe insulation with insulating cement. Finish cover assembly with insulating cement applied in two coats. After first coat is dry, apply and trowel second coat to a smooth finish.
 5. Unless a PVC jacket is indicated in field-applied jacket schedules, finish exposed surfaces with a metal jacket.

3.6 INSTALLATION OF FLEXIBLE ELASTOMERIC INSULATION

- A. Seal longitudinal seams and end joints with manufacturer's recommended adhesive to eliminate openings in insulation that allow passage of air to surface being insulated.
- B. Insulation Installation on Pipe Flanges:
 - 1. Install pipe insulation to outer diameter of pipe flange.
 - 2. Make width of insulation section same as overall width of flange and bolts, plus twice the thickness of pipe insulation.
 - 3. Fill voids between inner circumference of flange insulation and outer circumference of adjacent straight pipe segments with cut sections of sheet insulation of same thickness as pipe insulation.
 - 4. Secure insulation to flanges and seal seams with manufacturer's recommended adhesive to eliminate openings in insulation that allow passage of air to surface being insulated.
- C. Insulation Installation on Pipe Fittings and Elbows:
 - 1. Install mitered sections of pipe insulation.
 - 2. Secure insulation materials and seal seams with manufacturer's recommended adhesive to eliminate openings in insulation that allow passage of air to surface being insulated.
- D. Insulation Installation on Valves and Pipe Specialties:
 - 1. Install preformed valve covers manufactured of same material as pipe insulation when available.
 - 2. When preformed valve covers are not available, install cut sections of pipe and sheet insulation to valve body. Arrange insulation to permit access to packing and to allow valve operation without disturbing insulation.
 - 3. Install insulation to flanges as specified for flange insulation application.
 - 4. Secure insulation to valves and specialties and seal seams with manufacturer's recommended adhesive to eliminate openings in insulation that allow passage of air to surface being insulated.

3.7 INSTALLATION OF MINERAL-FIBER INSULATION

- A. Insulation Installation on Straight Pipes and Tubes:
 - 1. Secure each layer of preformed pipe insulation to pipe with wire or bands and tighten bands without deforming insulation materials.
 - 2. Where vapor barriers are indicated, seal longitudinal seams, end joints, and protrusions with vapor-barrier mastic and joint sealant.
 - 3. For insulation with factory-applied jackets on above-ambient surfaces, secure laps with outward clinched staples at 6 inches o.c.
 - 4. For insulation with factory-applied jackets on below-ambient surfaces, do not staple longitudinal tabs. Instead, secure tabs with additional adhesive as recommended by insulation material manufacturer and seal with vapor-barrier mastic and flashing sealant.
- B. Insulation Installation on Pipe Flanges:
 - 1. Install preformed pipe insulation to outer diameter of pipe flange.
 - 2. Make width of insulation section same as overall width of flange and bolts, plus twice the thickness of pipe insulation.
 - 3. Fill voids between inner circumference of flange insulation and outer circumference of adjacent straight pipe segments with mineral-fiber blanket insulation.
 - 4. Install jacket material with manufacturer's recommended adhesive, overlap seams at least 1 inch , and seal joints with flashing sealant.
- C. Insulation Installation on Pipe Fittings and Elbows:

1. Install preformed sections of same material as straight segments of pipe insulation when available.
2. When preformed insulation elbows and fittings are not available, install mitered sections of pipe insulation, to a thickness equal to adjoining pipe insulation. Secure insulation materials with wire or bands.

D. Insulation Installation on Valves and Pipe Specialties:

1. Install preformed sections of same material as straight segments of pipe insulation when available.
2. When preformed sections are not available, install mitered sections of pipe insulation to valve body.
3. Arrange insulation to permit access to packing and to allow valve operation without disturbing insulation.
4. Install insulation to flanges as specified for flange insulation application.

3.8 FIELD-APPLIED JACKET INSTALLATION

- A. Where PVC jackets are indicated, install with 1-inch overlap at longitudinal seams and end joints. Seal with manufacturer's recommended adhesive.
1. Apply two continuous beads of adhesive to seams and joints, one bead under lap and the finish bead along seam and joint edge.
- B. Where metal jackets are indicated, install with 2-inch overlap at longitudinal seams and end joints. Overlap longitudinal seams arranged to shed water. Seal end joints with weatherproof sealant recommended by insulation manufacturer. Secure jacket with stainless-steel bands 12 inches o.c. and at end joints.

3.9 PIPING INSULATION SCHEDULE, GENERAL

- A. Acceptable preformed pipe and tubular insulation materials and thicknesses are identified for each piping system and pipe size range. If more than one material is listed for a piping system, selection from materials listed is Contractor's option.
- B. Insulation shall have a k value that meets the minimum requirements of the latest International Energy Conservation Code (IECC).
- C. Items Not Insulated: Unless otherwise indicated, do not install insulation on the following:
1. Drainage piping located in crawl spaces.
 2. Underground piping.
 3. Chrome-plated pipes and fittings unless there is a potential for personnel injury.

3.10 INDOOR PIPING INSULATION SCHEDULE

A. Domestic Cold Water:

1. NPS 1-1/2 and Smaller: Insulation shall be one of the following:
 - a. Flexible Elastomeric:
 - 1) 1/2 inch thick
 - b. Mineral-Fiber, Preformed Pipe Insulation, Type I:
 - 1) 1/2 inch thick
2. NPS 2 and Larger: Insulation shall be one of the following:

- a. Flexible Elastomeric:
 - 1) 1/2 inches thick.
 - b. Mineral-Fiber, Preformed Pipe Insulation:
 - 1) 1/2 inches thick.
- B. Domestic Hot and Recirculated Hot Water:
- 1. NPS 1-1/2 and Smaller: Insulation shall be the following:
 - a. Mineral-Fiber, Preformed Pipe Insulation, Type I:
 - 1) 1 inch thick.
 - 2. NPS 2 and Larger: Insulation shall be the following:
 - a. Mineral-Fiber, Preformed Pipe Insulation, Type I:
 - 1) 1-1/2 inches thick
- C. Domestic Chilled Water (Potable):
- 1. All Pipe Sizes: Insulation shall be one of the following:
 - a. Flexible Elastomeric: 1 inch thick.
 - b. Mineral-Fiber, Preformed Pipe Insulation, Type I: 1 inch thick.
- D. Storm water and Overflow:
- 1. All Pipe Sizes: Insulation shall be one of the following:
 - a. Flexible Elastomeric: 1/2 inch thick.
 - b. Mineral-Fiber, Preformed Pipe Insulation, Type I: 1/2 inch thick.
- E. Roof Drain and Overflow Drain Bodies:
- 1. All Pipe Sizes: Insulation shall be one of the following:
 - a. Flexible Elastomeric: 1/2 inch thick.
 - b. Mineral-Fiber, Blanket Insulation, Type I: 1/2 inch thick.
 - c. Drain Manufacturer's Pre-formed bowl Insulation: 1/2 inch thick.
- F. Sanitary Waste Piping Where Heat Tracing Is Installed:
- 1. All Pipe Sizes: Insulation shall be the following:
 - a. Mineral-Fiber, Preformed Pipe Insulation, Type I: 1-1/2 inches thick.
- G. Floor Drains, Traps, and Sanitary Drain Piping within 10 Feet of Drain Receiving Condensate and Equipment Drain Water below 60 Deg F :
- 1. All Pipe Sizes: Insulation shall be one of the following:
 - a. Flexible Elastomeric:
 - 1) 3/4 inch thick.
 - b. Mineral-Fiber, Preformed Pipe Insulation, Type I:
 - 1) 3/4 inch thick.
- H. Hot Service Drains:
- 1. All Pipe Sizes: Insulation shall be the following:

- a. Mineral-Fiber, Preformed Pipe, Type I or II: 1 inch thick.
- I. Hot Service Vents:
 - 1. All Pipe Sizes: Insulation shall be the following:
 - a. Mineral-Fiber, Preformed Pipe, Type I or II: 1 inch thick.

3.11 OUTDOOR, ABOVEGROUND PIPING INSULATION SCHEDULE

- A. Domestic Water Piping:
 - 1. All Pipe Sizes: Insulation shall be one of the following:
 - a. Flexible Elastomeric: 2 inches thick.
 - b. Mineral-Fiber, Preformed Pipe Insulation, Type I: 2 inches thick.
- B. Domestic Hot and Recirculated Hot Water:
 - 1. All Pipe Sizes: Insulation shall be the following:
 - a. Mineral-Fiber, Preformed Pipe Insulation, Type I: 2 inches thick.
- C. Sanitary Waste Piping Where Heat Tracing Is Installed:
 - 1. All Pipe Sizes: Insulation shall be the following:
 - a. Mineral-Fiber, Preformed Pipe Insulation, Type I: 2 inches thick.
- D. Hot Service Drains:
 - 1. All Pipe Sizes: Insulation shall be the following:
 - a. Mineral-Fiber, Preformed Pipe Insulation, Type I: 1 inch thick.
- E. Hot Service Vents:
 - 1. All Pipe Sizes: Insulation shall be the following:
 - a. Mineral-Fiber, Preformed Pipe Insulation, Type II: 1 inch thick.

3.12 INDOOR, FIELD-APPLIED JACKET SCHEDULE

- A. Install jacket over insulation material. For insulation with factory-applied jacket, install the field-applied jacket over the factory-applied jacket.
- B. If more than one material is listed, selection from materials listed is Contractor's option.
- C. Piping, Concealed:
 - 1. None.
- D. Piping, Exposed:
 - 1. PVC:
 - a. PVC, white: 30 mils thick.

3.13 OUTDOOR, FIELD-APPLIED JACKET SCHEDULE

- A. Install jacket over insulation material. For insulation with factory-applied jacket, install the field-applied jacket over the factory-applied jacket.
- B. If more than one material is listed, selection from materials listed is Contractor's option.
- C. Piping, Concealed:
 - 1. None.
- D. Piping, Exposed:
 - 1. Aluminum, Stucco Embossed: 0.016 inch thick.

3.14 UNDERGROUND, FIELD-INSTALLED INSULATION JACKET

- A. For underground direct-buried piping applications, install underground direct-buried jacket over insulation material.

END OF SECTION 22 0719

THIS PAGE LEFT BLANK INTENTIONALLY

SECTION 22 1116

DOMESTIC WATER PIPING

PART 1 - GENERAL

1.1 RELATED DOCUMENTS

- A. Drawings and general provisions of the Contract, including General and Supplementary Conditions and Division 01 Specification Sections, apply to this Section.

1.2 SUMMARY

- A. Section Includes:

- 1. Aboveground domestic water pipes, tubes, and fittings inside buildings.

- B. Related Requirements:

- 1. Division 22 Section "Facility Water Distribution Piping" for water-service piping outside the building from source to the point where water-service piping enters the building.

1.3 SEISMIC REQUIREMENTS

- A. Seismic Performance: Pipe hangers and supports shall withstand the effects of earthquake motions determined according to SEI/ASCE 7 and with the requirements specified in Section 230548 "Vibration and Seismic Controls for HVAC."

- 1. For piping with a seismic importance factor of 1.0 the term "withstand" means "the system will remain in place without separation of any parts when subjected to the seismic forces specified."
- 2. For piping with a seismic importance factor of 1.5 the term "withstand" means "the system will remain in place without separation of any parts when subjected to the seismic forces specified and the system will be fully operational after the seismic event."

1.4 ACTION SUBMITTALS

- A. Product Data: For transition fittings and dielectric fittings.

- B. Delegated-Design Submittal:

- 1. Design calculations and detailed fabrication and assembly of pipe anchors and alignment guides, hangers and supports for multiple pipes, expansion joints and loops, and attachments of the same to the building structure.
- 2. Locations of pipe anchors and alignment guides and expansion joints and loops.
- 3. Locations of and details for penetrations, including sleeves and sleeve seals for exterior walls, floors, basement, and foundation walls.

1.5 INFORMATIONAL SUBMITTALS

- A. System purging and disinfecting activities report.
- B. Field quality-control reports.

1.6 FIELD CONDITIONS

- A. Interruption of Existing Water Service: Do not interrupt water service to facilities occupied by Owner or others unless permitted under the following conditions and then only after arranging to provide temporary water service according to requirements indicated:
 - 1. Notify Construction Manager or owner no fewer than two days in advance of proposed interruption of water service.

PART 2 - PRODUCTS

2.1 PIPING MATERIALS

- A. Comply with requirements in "Piping Schedule" Article for applications of pipe, tube, fitting materials, and joining methods for specific services, service locations, and pipe sizes.
- B. Potable-water piping and components shall comply with NSF 14 and NSF 61. Plastic piping components shall be marked with "NSF-pw."
- C. All piping shall be American made and tested; no import pipe will be permitted.
- D. All exposed water supply piping in toilet rooms, custodial rooms and kitchens shall be chromium plated.
- E. All piping installed in or passing through a plenum must be plenum rated, fire wrapped, or installed in a metal conduit.

2.2 COPPER TUBE AND FITTINGS

- A. Hard Copper Tube: ASTM B 88, Type K and ASTM B 88, Type L water tube, drawn temper.
- B. Soft Copper Tube: ASTM B 88, Type K and ASTM B 88, Type L water tube, annealed temper.
- C. Cast-Copper, Solder-Joint Fittings: ASME B16.18, pressure fittings.
- D. Wrought-Copper, Solder-Joint Fittings: ASME B16.22, wrought-copper pressure fittings.
- E. Bronze Flanges: ASME B16.24, Class 150, with solder-joint ends.
- F. Copper Unions:
 - 1. MSS SP-123.
 - 2. Cast-copper-alloy, hexagonal-stock body.
 - 3. Ball-and-socket, metal-to-metal seating surfaces.
 - 4. Solder-joint or threaded ends.
- G. Appurtenances for Grooved-End Copper Tubing:

1. Manufacturers: Subject to compliance with requirements, provide products by one of the following:
 - a. Victaulic Company.

2.3 PIPING JOINING MATERIALS

- A. Pipe-Flange Gasket Materials:
 1. AWWA C110/A21.10, rubber, flat face, 1/8 inch thick or ASME B16.21, nonmetallic and asbestos free unless otherwise indicated.
 2. Full-face or ring type unless otherwise indicated.
- B. Metal, Pipe-Flange Bolts and Nuts: ASME B18.2.1, carbon steel unless otherwise indicated.
- C. Solder Filler Metals: ASTM B 32, lead-free alloys.
- D. Flux: ASTM B 813, water flushable.
- E. Brazing Filler Metals: AWS A5.8/A5.8M, BCuP Series, copper-phosphorus alloys for general-duty brazing unless otherwise indicated.

PART 3 - EXECUTION

3.1 EARTHWORK

- A. Comply with requirements in Division 31 Section "Earth Moving" for excavating, trenching, and backfilling.

3.2 PIPING INSTALLATION

- A. Drawing plans, schematics, and diagrams indicate general location and arrangement of domestic water piping. Indicated locations and arrangements are used to size pipe and calculate friction loss, expansion, and other design considerations. Install piping as indicated unless deviations to layout are approved on coordination drawings.
- B. Install shutoff valve immediately upstream of each dielectric fitting.
- C. Install domestic water piping with 0.25 percent slope downward toward drain and plumb.
- D. Install seismic restraints on piping. Comply with SEI/ASCE 7 and with requirements for seismic-restraint devices in Division 22 Section "Vibration and Seismic Controls for Plumbing Piping and Equipment."
- E. Install piping concealed from view and protected from physical contact by building occupants unless otherwise indicated and except in equipment rooms and service areas.
- F. Install piping indicated to be exposed and piping in equipment rooms and service areas at right angles or parallel to building walls. Diagonal runs are prohibited unless specifically indicated otherwise.
- G. Install piping above accessible ceilings to allow sufficient space for ceiling panel removal, and coordinate with other services occupying that space.

- H. Install piping to permit valve servicing.
- I. Install nipples, unions, special fittings, and valves with pressure ratings the same as or higher than the system pressure rating used in applications below unless otherwise indicated.
- J. Install piping free of sags and bends.
- K. Install fittings for changes in direction and branch connections.
- L. Install unions in copper tubing at final connection to each piece of equipment, machine, and specialty.
- M. Install pressure gages on suction and discharge piping for each plumbing pump and packaged booster pump. Comply with requirements for pressure gages in Division 22 Section "Meters and Gages for Plumbing Piping."
- N. Install sleeves for piping penetrations of walls, ceilings, and floors. Comply with requirements for sleeves specified in Division 22 Section "Sleeves and Sleeve Seals for Plumbing Piping."
- O. Install escutcheons for piping penetrations of walls, ceilings, and floors. Comply with requirements for escutcheons specified in Division 22 Section "Escutcheons for Plumbing Piping."

3.3 JOINT CONSTRUCTION

- A. Ream ends of pipes and tubes and remove burrs. Bevel plain ends of steel pipe.
- B. Remove scale, slag, dirt, and debris from inside and outside of pipes, tubes, and fittings before assembly.
- C. Threaded Joints: Thread pipe with tapered pipe threads according to ASME B1.20.1. Cut threads full and clean using sharp dies. Ream threaded pipe ends to remove burrs and restore full ID. Join pipe fittings and valves as follows:
 - 1. Apply appropriate tape or thread compound to external pipe threads.
 - 2. Damaged Threads: Do not use pipe or pipe fittings with threads that are corroded or damaged.
- D. Brazed Joints for Copper Tubing: Comply with CDA's "Copper Tube Handbook," "Braze Joints" chapter.
- E. Soldered Joints for Copper Tubing: Apply ASTM B 813, water-flushable flux to end of tube. Join copper tube and fittings according to ASTM B 828 or CDA's "Copper Tube Handbook."
- F. Flanged Joints: Select appropriate asbestos-free, nonmetallic gasket material in size, type, and thickness suitable for domestic water service. Join flanges with gasket and bolts according to ASME B31.9.
- G. Joints for Dissimilar-Material Piping: Make joints using adapters compatible with materials of both piping systems.

3.4 HANGER AND SUPPORT INSTALLATION

- A. Comply with requirements for seismic-restraint devices in Division 22 Section "Vibration and Seismic Controls for Plumbing Piping and Equipment."

- B. Comply with requirements for pipe hanger, support products, and installation in Division 22 Section "Hangers and Supports for Plumbing Piping and Equipment."
 - 1. Vertical Piping: MSS Type 8 or 42, clamps.
 - 2. Individual, Straight, Horizontal Piping Runs:
 - a. 100 Feet and Less: MSS Type 1, adjustable, steel clevis hangers.
 - b. Longer Than 100 Feet: MSS Type 43, adjustable roller hangers.
 - c. Longer Than 100 Feet if Indicated: MSS Type 49, spring cushion rolls.
 - 3. Multiple, Straight, Horizontal Piping Runs 100 Feet or Longer: MSS Type 44, pipe rolls. Support pipe rolls on trapeze.
 - 4. Base of Vertical Piping: MSS Type 52, spring hangers.
- C. Support vertical piping and tubing at base and at each floor.
- D. Rod diameter may be reduced one size for double-rod hangers, to a minimum of 3/8 inch.
- E. Install hangers for copper tubing with the following maximum horizontal spacing and minimum rod diameters:
 - 1. NPS 3/4 and Smaller: 60 inches with 3/8-inch rod.
 - 2. NPS 1 and NPS 1-1/4: 72 inches with 3/8-inch rod.
 - 3. NPS 1-1/2 and NPS 2: 96 inches with 3/8-inch rod.
 - 4. NPS 2-1/2: 108 inches with 1/2-inch rod.
 - 5. NPS 3 to NPS 5: 10 feet with 1/2-inch rod.
 - 6. NPS 6: 10 feet with 5/8-inch rod.
 - 7. NPS 8: 10 feet with 3/4-inch rod.
- F. Install supports for vertical copper tubing every 10 feet.
- G. Support piping and tubing not listed in this article according to MSS SP-69 and manufacturer's written instructions.

3.5 CONNECTIONS

- A. Drawings indicate general arrangement of piping, fittings, and specialties.
- B. When installing piping adjacent to equipment and machines, allow space for service and maintenance.
- C. Connect domestic water piping to water-service piping with shutoff valve; extend and connect to the following:
 - 1. Plumbing Fixtures: Cold- and hot-water-supply piping in sizes indicated, but not smaller than that required by plumbing code. Comply with requirements for connection sizes in Division 22 plumbing fixture Sections.
 - 2. Equipment: Cold- and hot-water-supply piping as indicated, but not smaller than equipment connections. Provide shutoff valve and union for each connection. Use flanges instead of unions for NPS 2-1/2 and larger.

3.6 IDENTIFICATION

- A. Identify system components. Comply with requirements for identification materials and installation in Division 22 Section "Identification for Plumbing Piping and Equipment."
- B. Label pressure piping with system operating pressure.

3.7 FIELD QUALITY CONTROL

A. Perform the following tests and inspections:

1. Piping Inspections:

- a. Do not enclose, cover, or put piping into operation until it has been inspected and approved by authorities having jurisdiction.
- b. During installation, notify authorities having jurisdiction at least one day before inspection must be made. Perform tests specified below in presence of authorities having jurisdiction:
 - 1) Roughing-in Inspection: Arrange for inspection of piping before concealing or closing in after roughing in and before setting fixtures.
 - 2) Final Inspection: Arrange for authorities having jurisdiction to observe tests specified in "Piping Tests" Subparagraph below and to ensure compliance with requirements.
- c. Reinspection: If authorities having jurisdiction find that piping will not pass tests or inspections, make required corrections and arrange for reinspection.
- d. Reports: Prepare inspection reports and have them signed by authorities having jurisdiction.

2. Piping Tests:

- a. Fill domestic water piping. Check components to determine that they are not air bound and that piping is full of water.
- b. Test for leaks and defects in new piping and parts of existing piping that have been altered, extended, or repaired. If testing is performed in segments, submit a separate report for each test, complete with diagram of portion of piping tested.
- c. Leave new, altered, extended, or replaced domestic water piping uncovered and unconcealed until it has been tested and approved. Expose work that was covered or concealed before it was tested.
- d. Cap and subject piping to static water pressure of 50 psig above operating pressure, without exceeding pressure rating of piping system materials. Isolate test source and allow it to stand for four hours. Leaks and loss in test pressure constitute defects that must be repaired.
- e. Repair leaks and defects with new materials, and retest piping or portion thereof until satisfactory results are obtained.
- f. Prepare reports for tests and for corrective action required.

B. Domestic water piping will be considered defective if it does not pass tests and inspections.

C. Prepare test and inspection reports.

3.8 ADJUSTING

A. Perform the following adjustments before operation:

1. Close drain valves, hydrants, and hose bibbs.
2. Open shutoff valves to fully open position.
3. Open throttling valves to proper setting.
4. Adjust balancing valves in hot-water-circulation return piping to provide adequate flow.
 - a. Manually adjust ball-type balancing valves in hot-water-circulation return piping to provide hot-water flow in each branch.
 - b. Adjust calibrated balancing valves to flows indicated.

5. Remove plugs used during testing of piping and for temporary sealing of piping during installation.
6. Remove and clean strainer screens. Close drain valves and replace drain plugs.
7. Remove filter cartridges from housings and verify that cartridges are as specified for application where used and are clean and ready for use.
8. Check plumbing specialties and verify proper settings, adjustments, and operation.

3.9 CLEANING

A. Clean and disinfect potable domestic water piping as follows:

1. Purge new piping and parts of existing piping that have been altered, extended, or repaired before using.
2. Use purging and disinfecting procedures prescribed by authorities having jurisdiction; if methods are not prescribed, use procedures described in either AWWA C651 or AWWA C652 or follow procedures described below:
 - a. Flush piping system with clean, potable water until dirty water does not appear at outlets.
 - b. Fill and isolate system according to either of the following:
 - 1) Fill system or part thereof with water/chlorine solution with at least 50 ppm of chlorine. Isolate with valves and allow to stand for 24 hours.
 - 2) Fill system or part thereof with water/chlorine solution with at least 200 ppm of chlorine. Isolate and allow to stand for three hours.
 - c. Flush system with clean, potable water until no chlorine is in water coming from system after the standing time.
 - d. Repeat procedures if biological examination shows contamination.
 - e. Submit water samples in sterile bottles to authorities having jurisdiction.

B. Clean non-potable domestic water piping as follows:

1. Purge new piping and parts of existing piping that have been altered, extended, or repaired before using.
2. Use purging procedures prescribed by authorities having jurisdiction or; if methods are not prescribed, follow procedures described below:
 - a. Flush piping system with clean, potable water until dirty water does not appear at outlets.
 - b. Submit water samples in sterile bottles to authorities having jurisdiction. Repeat procedures if biological examination shows contamination.

C. Prepare and submit reports of purging and disinfecting activities. Include copies of water-sample approvals from authorities having jurisdiction.

D. Clean interior of domestic water piping system. Remove dirt and debris as work progresses.

3.10 PIPING SCHEDULE

- A. Some piping types and sizes mentioned in this section may not be used on this project.
- B. Transition and special fittings with pressure ratings at least equal to piping rating may be used in applications below unless otherwise indicated.
- C. Flanges and unions may be used for aboveground piping joints unless otherwise indicated.

- D. All exposed water supply piping in toilet rooms, custodial rooms and kitchens shall be chromium plated.
- E. Aboveground domestic water piping, NPS 2 and smaller, shall be the following:
 - 1. Hard copper tube, ASTM B 88, Type L; cast- copper, solder-joint fittings; and soldered joints.
- F. Aboveground domestic water piping, NPS 2-1/2 to NPS 4, shall be the following:
 - 1. Hard copper tube, ASTM B 88, Type L; cast- copper, brazed-joint fittings; and brazed joints.

3.11 VALVE SCHEDULE

- A. Drawings indicate valve types to be used. Where specific valve types are not indicated, the following requirements apply:
 - 1. Shutoff Duty: Use ball for piping NPS 3 and smaller. Use butterfly or ball, with flanged ends for piping NPS 4 and larger.
 - 2. Throttling Duty: Use ball valves for piping NPS 2 and smaller. Use butterfly or ball valves with flanged ends for piping NPS 2-1/2 and larger.
 - 3. Hot-Water Circulation Piping, Balancing Duty: Calibrated balancing valves.
 - 4. Drain Duty: Hose-end drain valves.
- B. Use check valves to maintain correct direction of domestic water flow to and from equipment.

END OF SECTION 22 1116

SECTION 22 1119

DOMESTIC WATER PIPING SPECIALTIES

PART 1 - GENERAL

1.1 RELATED DOCUMENTS

- A. Drawings and general provisions of the Contract, including General and Supplementary Conditions and Division 01 Specification Sections, apply to this Section.

1.2 SUMMARY

- A. This Section includes the following domestic water piping specialties:
 - 1. Vacuum breakers.
 - 2. Backflow preventers.
 - 3. Water pressure-reducing valves.
 - 4. Balancing valves.
 - 5. Strainers.
 - 6. Outlet boxes.
 - 7. Hose bibbs.
 - 8. Drain valves.
 - 9. Water hammer arresters.
- B. Related Sections include the following:
 - 1. Division 22 Section "Meters and Gages for Plumbing Piping" for thermometers, pressure gages, and flow meters in domestic water piping.
 - 2. Division 22 Section "Emergency Plumbing Fixtures" for water tempering equipment.

1.3 PERFORMANCE REQUIREMENTS

- A. Minimum Working Pressure for Domestic Water Piping Specialties: 125 psig, unless otherwise indicated.

1.4 SUBMITTALS

- A. Product Data: For each type of product indicated.
- B. Shop Drawings: Diagram power, signal, and control wiring.
- C. Field quality-control test reports.
- D. Operation and Maintenance Data: For domestic water piping specialties to include in emergency, operation, and maintenance manuals.

1.5 QUALITY ASSURANCE

- A. Electrical Components, Devices, and Accessories: Listed and labeled as defined in NFPA 70, Article 100, by a testing agency acceptable to authorities having jurisdiction, and marked for intended use.

B. NSF Compliance:

1. Comply with NSF 14, "Plastics Piping Components and Related Materials," for plastic domestic water piping components.
2. Comply with NSF 61, "Drinking Water System Components - Health Effects; Sections 1 through 9."

PART 2 - PRODUCTS

2.1 VACUUM BREAKERS

A. Pipe-Applied, Atmospheric-Type Vacuum Breakers:

1. Manufacturers: Subject to compliance with requirements, provide products by one of the following:
 - a. Ames Co.
 - b. Cash Acme.
 - c. Conbraco Industries, Inc.
 - d. FEBCO; SPX Valves & Controls.
 - e. Rain Bird Corporation.
 - f. Toro Company (The); Irrigation Div.
 - g. Watts Industries, Inc.; Water Products Div.
 - h. Zurn Plumbing Products Group; Wilkins Div.
2. Standard: ASSE 1001.
3. Size: NPS 1/4 to NPS 3, as required to match connected piping.
4. Body: Bronze.
5. Inlet and Outlet Connections: Threaded.
6. Finish: Chrome plated.

B. Hose-Connection Vacuum Breakers:

1. Manufacturers: Subject to compliance with requirements, provide products by one of the following:
 - a. Arrowhead Brass Products, Inc.
 - b. Cash Acme.
 - c. Conbraco Industries, Inc.
 - d. MIFAB, Inc.
 - e. Prier Products, Inc.
 - f. Watts Industries, Inc.; Water Products Div.
 - g. Woodford Manufacturing Company.
 - h. Zurn Plumbing Products Group; Light Commercial Operation.
 - i. Zurn Plumbing Products Group; Wilkins Div.
2. Standard: ASSE 1011.
3. Body: Bronze, nonremovable, with manual drain.
4. Outlet Connection: Garden-hose threaded complying with ASME B1.20.7.
5. Finish: Chrome or nickel plated.

C. Pressure Vacuum Breakers:

1. Manufacturers: Subject to compliance with requirements, provide products by one of the following:
 - a. Ames Co.

- b. Conbraco Industries, Inc.
 - c. FEBCO; SPX Valves & Controls.
 - d. Flomatic Corporation.
 - e. Toro Company (The); Irrigation Div.
 - f. Watts Industries, Inc.; Water Products Div.
 - g. Zurn Plumbing Products Group; Wilkins Div.
- 2. Standard: ASSE 1020.
 - 3. Operation: Continuous-pressure applications.
 - 4. Pressure Loss: 5 psig maximum, through middle 1/3 of flow range.
 - 5. Accessories:
 - a. Valves: Ball type, on inlet and outlet.
- D. Spill-Resistant Vacuum Breakers:
- 1. Manufacturers: Subject to compliance with requirements, provide products by one of the following:
 - a. Conbraco Industries, Inc.
 - b. Watts Industries, Inc.; Water Products Div.
 - 2. Standard: ASSE 1056.
 - 3. Operation: Continuous-pressure applications.
 - 4. Accessories:
 - a. Valves: Ball type, on inlet and outlet.

2.2 BACKFLOW PREVENTERS

- A. Reduced-Pressure-Principle Backflow Preventers:
- 1. Manufacturers: Subject to compliance with requirements, provide products by one of the following:
 - a. Ames Co.
 - b. FEBCO; SPX Valves & Controls.
 - c. Flomatic Corporation.
 - d. Watts Industries, Inc.; Water Products Div.
 - e. Zurn Plumbing Products Group; Wilkins Div.
 - 2. Standard: ASSE 1013.
 - 3. Operation: Continuous-pressure applications.
 - 4. Pressure Loss: 12 psig maximum, through middle 1/3 of flow range.
 - 5. Body: Bronze for NPS 2 and smaller; cast iron with interior lining complying with AWWA C550 or that is FDA approved] for NPS 2-1/2 and larger.
 - 6. End Connections: Threaded for NPS 2 and smaller; flanged for NPS 2-1/2 and larger.
 - 7. Accessories:
 - a. Valves: Ball type with threaded ends on inlet and outlet of NPS 2 and smaller; outside screw and yoke gate-type with flanged ends on inlet and outlet of NPS 2-1/2 and larger.
 - b. Air-Gap Fitting: ASME A112.1.2, matching backflow-preventer connection.
- B. Double-Check Backflow-Prevention Assemblies:
- 1. Manufacturers: Subject to compliance with requirements, provide products by one of the following:

- a. Ames Co.
 - b. Conbraco Industries, Inc.
 - c. FEBCO; SPX Valves & Controls.
 - d. Flomatic Corporation.
 - e. Watts Industries, Inc.; Water Products Div.
 - f. Zurn Plumbing Products Group; Wilkins Div.
2. Standard: ASSE 1015.
 3. Operation: Continuous-pressure applications, unless otherwise indicated.
 4. Pressure Loss: 5 psig maximum, through middle 1/3 of flow range.
 5. Body: Bronze for NPS 2 and smaller; cast iron with interior lining complying with AWWA C550 or that is FDA approved for NPS 2-1/2 and larger.
 6. End Connections: Threaded for NPS 2 and smaller; [flanged] <Insert type> for NPS 2-1/2 and larger.
 7. Accessories:
 - a. Valves: Ball type with threaded ends on inlet and outlet of NPS 2 and smaller; outside screw and yoke gate-type with flanged ends on inlet and outlet of NPS 2-1/2 and larger.

C. Dual-Check-Valve Backflow Preventers:

1. Manufacturers: Subject to compliance with requirements, provide products by one of the following:
 - a. Cash Acme.
 - b. Conbraco Industries, Inc.
 - c. FEBCO; SPX Valves & Controls.
 - d. Flomatic Corporation.
 - e. Ford Meter Box Company, Inc. (The).
 - f. Honeywell Water Controls.
 - g. McDonald, A. Y. Mfg. Co.
 - h. Mueller Co.; Water Products Div.
 - i. Watts Industries, Inc.; Water Products Div.
 - j. Zurn Plumbing Products Group; Wilkins Div.
2. Standard: ASSE 1024.
3. Operation: Continuous-pressure applications.
4. Body: Bronze with union inlet.

2.3 WATER PRESSURE-REDUCING VALVES

A. Water Regulators: (Direct Type)

1. Manufacturers: Subject to compliance with requirements, provide products by one of the following:
 - a. Cash Acme.
 - b. Conbraco Industries, Inc.
 - c. Honeywell Water Controls.
 - d. Watts Industries, Inc.; Water Products Div.
 - e. Zurn Plumbing Products Group; Wilkins Div.
2. Standard: ASSE 1003.
3. Pressure Rating: Initial working pressure of 150 psig.
4. Body: Bronze, provide chrome-plated finish if connected to chrome plated or stainless steel piping for NPS 2 and smaller; cast iron with interior lining complying with AWWA C550 or that is FDA approved for NPS 2-1/2 and NPS 3.

5. Valves for Booster Heater Water Supply: Include integral bypass.
6. End Connections: Threaded for NPS 2 and smaller; flanged for NPS 2-1/2 and NPS 3.

2.4 BALANCING VALVES

A. Copper-Alloy Calibrated Balancing Valves:

1. Manufacturers: Subject to compliance with requirements, provide products by one of the following:
 - a. Armstrong International, Inc.
 - b. Flo Fab Inc.
 - c. ITT Industries; Bell & Gossett Div.
 - d. NIBCO INC.
 - e. TAC Americas.
 - f. Taco, Inc.
 - g. Victaulic
 - h. Watts Industries, Inc.; Water Products Div.
 - i. Nexus
 - j. Bell & Gossett
2. Type: Ball or Y-pattern globe valve with two readout ports and memory setting indicator.
3. Body: bronze,
4. Size: Same as connected piping, but not larger than NPS 2.
5. Accessories: Meter hoses, fittings, valves, differential pressure meter, and carrying case.

2.5 STRAINERS FOR DOMESTIC WATER PIPING

A. Y-Pattern Strainers:

1. Pressure Rating: Class 250
2. Body: Bronze for NPS 2 and smaller; cast iron with interior lining complying with AWWA C550 or FDA-approved, epoxy coating and for NPS 2-1/2 and larger.
3. End Connections: Threaded for NPS 2 and smaller; flanged for NPS 2-1/2 and larger.
4. Screen: Stainless steel with round perforations, unless otherwise indicated.
5. Perforation Size:
 - a. Strainers NPS 2 and Smaller: 0.020 inch.
6. Drain: Factory-installed, hose-end drain valve.
7. Manufacturers: Subject to compliance with requirements, provide products by one of the following:
 - a. Armstrong International, Inc.
 - b. Flo Fab Inc.
 - c. ITT Industries; Bell & Gossett Div.
 - d. NIBCO INC.
 - e. TAC Americas.
 - f. Taco, Inc.
 - g. Victaulic
 - h. Watts Industries, Inc.; Water Products Div.
 - i. Nexus
 - j. Bell & Gossett

2.6 OUTLET BOXES

A. Icemaker Outlet Boxes:

1. Manufacturers: Subject to compliance with requirements, provide products by one of the following:
 - a. Acorn Engineering Company.
 - b. Guy Gray Manufacturing Co., Inc.
 - c. IPS Corporation.
 - d. LSP Products Group, Inc.
 - e. Oatey.
 - f. Plastic Oddities; a division of Diverse Corporate Technologies.
 - g. Symmons Industries, Inc.
 - h. Watts Industries, Inc.; Water Products Div.
 - i. Whitehall Manufacturing; a div. of Acorn Engineering Company.
 - j. Zurn Plumbing Products Group; Light Commercial Operation.
2. Mounting: Recessed.
3. Material and Finish: Enameled-steel or epoxy-painted-steel or plastic box and faceplate.
4. Faucet: Combination, valved fitting or separate hot- and cold-water, valved fittings complying with ASME A112.18.1. Include garden-hose thread complying with ASME B1.20.7 on outlets.
5. Supply Shutoff Fittings: NPS 1/2 gate, globe, or ball valves and NPS 1/2 copper, water tubing.
6. Drain: NPS 2 standpipe and P-trap for direct waste connection to drainage piping.
7. Inlet Hoses: Two 60-inch- long, rubber household clothes washer inlet hoses with female, garden-hose-thread couplings. Include rubber washers.
8. Drain Hose: One 48-inch- long, rubber household clothes washer drain hose with hooked end.

B. Water Outlet Boxes:

1. Manufacturers: Subject to compliance with requirements, provide products by one of the following:
 - a. Acorn Engineering Company.
 - b. IPS Corporation.
 - c. LSP Products Group, Inc.
 - d. Oatey.
 - e. Plastic Oddities; a division of Diverse Corporate Technologies.
2. Mounting: Recessed.
3. Material and Finish: Enameled-steel or epoxy-painted-steel or plastic box and faceplate.
4. Faucet: Valved fitting complying with ASME A112.18.1. Include NPS 1/2 or smaller copper tube outlet.
5. Supply Shutoff Fitting: NPS 1/2 gate, globe, or ball valve and NPS 1/2 copper, water tubing.

2.7 HOSE BIBBS

A. Hose Bibbs:

1. Standard: ASME A112.18.1 for sediment faucets.
2. Body Material: Bronze.
3. Seat: Bronze, replaceable.
4. Supply Connections: NPS 1/2 or NPS 3/4 threaded or solder-joint inlet.
5. Outlet Connection: Garden-hose thread complying with ASME B1.20.7.
6. Pressure Rating: 125 psig.

7. Vacuum Breaker: Integral or field-installation, nonremovable, drainable, hose-connection vacuum breaker complying with ASSE 1011.
8. Finish for Equipment Rooms: Rough bronze, or chrome or nickel plated.
9. Finish for Service Areas: Chrome or nickel plated.
10. Finish for Finished Rooms: Chrome or nickel plated.
11. Operation for Equipment Rooms: Wheel handle or operating key.
12. Operation for Service Areas: Wheel handle.
13. Operation for Finished Rooms: Operating key.
14. Include operating key with each operating-key hose bibb.
15. Include integral wall flange with each chrome- or nickel-plated hose bibb.

2.8 DRAIN VALVES

A. Ball-Valve-Type, Hose-End Drain Valves:

1. Standard: MSS SP-110 for standard-port, two-piece ball valves.
2. Pressure Rating: 400-psig minimum CWP.
3. Size: NPS 3/4.
4. Body: Copper alloy.
5. Ball: Chrome-plated brass.
6. Seats and Seals: Replaceable.
7. Handle: Vinyl-covered steel.
8. Inlet: Threaded or solder joint.
9. Outlet: Threaded, short nipple with garden-hose thread complying with ASME B1.20.7 and cap with brass chain.

2.9 WATER HAMMER ARRESTERS

A. Water Hammer Arresters:

1. Manufacturers: Subject to compliance with requirements, provide products by one of the following:
 - a. AMTROL, Inc.
 - b. Josam Company.
 - c. MIFAB, Inc.
 - d. PPP Inc.
 - e. Sioux Chief Manufacturing Company, Inc.
 - f. Smith, Jay R. Mfg. Co.; Division of Smith Industries, Inc.
 - g. Tyler Pipe; Wade Div.
 - h. Watts Drainage Products Inc.
 - i. Zurn Plumbing Products Group; Specification Drainage Operation.
2. Standard: ASSE 1010 or PDI-WH 201.
3. Type: Metal bellows or Copper tube with piston.
4. Size: ASSE 1010, Sizes AA and A through F or PDI-WH 201, Sizes A through F.

PART 3 - EXECUTION

3.1 INSTALLATION

- A. Refer to Division 22 Section "Common Work Results for Plumbing" for piping joining materials, joint construction, and basic installation requirements.

- B. Install backflow preventers in each water supply to mechanical equipment and systems and to other equipment and water systems that may be sources of contamination. Comply with authorities having jurisdiction.
 - 1. Locate backflow preventers in same room as connected equipment or system.
 - 2. Install drain for backflow preventers with atmospheric-vent drain connection with air-gap fitting, fixed air-gap fitting, or equivalent positive pipe separation of at least two pipe diameters in drain piping and pipe to floor drain. Locate air-gap device attached to or under backflow preventer. Simple air breaks are not acceptable for this application.
 - 3. Do not install bypass piping around backflow preventers.
- C. Install water control valves with inlet and outlet shutoff valves. Install pressure gages on inlet and outlet.
- D. Install balancing valves in locations where they can easily be adjusted.
- E. Install Y-pattern strainers for water on supply side of each control valve, water pressure-reducing valve, solenoid valve, and pump.
- F. Install outlet boxes recessed in wall. Install 2-by-4-inch fire-retardant-treated-wood blocking wall reinforcement between studs. Fire-retardant-treated-wood blocking is specified in Division 06 Section "Rough Carpentry."
- G. Install water hammer arresters in water piping according to PDI-WH 201.
- H. Install all reducing valves in an accessible space 5 feet above finished floor.
- I. Install ball valve on strainer to allow for draining.

3.2 CONNECTIONS

- A. Piping installation requirements are specified in other Division 22 Sections. Drawings indicate general arrangement of piping and specialties.
- B. Ground equipment according to Division 26 Section "Grounding and Bonding for Electrical Systems."
- C. Connect wiring according to Division 26 Section "Low-Voltage Electrical Power Conductors and Cables."

3.3 LABELING AND IDENTIFYING

- A. Equipment Nameplates and Signs: Install engraved plastic-laminate equipment nameplate or sign on or near each of the following:
 - 1. Pressure vacuum breakers.
 - 2. Reduced-pressure-principle backflow preventers.
 - 3. Double-check backflow-prevention assemblies.
 - 4. Carbonated-beverage-machine backflow preventers.
 - 5. Dual-check-valve backflow preventers.
 - 6. Water pressure-reducing valves.
 - 7. Calibrated balancing valves.
 - 8. Outlet boxes.
- B. Distinguish among multiple units, inform operator of operational requirements, indicate safety and emergency precautions, and warn of hazards and improper operations, in addition to

identifying unit. Nameplates and signs are specified in Division 22 Section "Identification for Plumbing Piping and Equipment."

3.4 FIELD QUALITY CONTROL

- A. Perform the following tests and prepare test reports:
 - 1. Test each backflow preventer according to authorities having jurisdiction and the device's reference standard.
- B. Remove and replace malfunctioning domestic water piping specialties and retest as specified above.

3.5 ADJUSTING

- A. Set field-adjustable pressure set points of water pressure-reducing valves.

- B. Set field-adjustable flow set points of balancing valves.

END OF SECTION 22 1119

SECTION 22 1316

SANITARY WASTE AND VENT PIPING

PART 1 - GENERAL

1.1 RELATED DOCUMENTS

- A. Drawings and general provisions of the Contract, including General and Supplementary Conditions and Division 01 Specification Sections, apply to this Section.

1.2 SUMMARY

- A. Section Includes:
 - 1. Pipe, tube, and fittings.
 - 2. Specialty pipe fittings.

1.3 DEFINITIONS

- A. EPDM: Ethylene-propylene-diene terpolymer rubber.
- B. PVC: Polyvinyl chloride plastic.

1.4 PERFORMANCE REQUIREMENTS

- A. Components and installation shall be capable of withstanding the following minimum working pressure unless otherwise indicated:
 - 1. Soil, Waste, and Vent Piping: 10-foot head of water.
- B. Seismic Performance: Soil, waste, and vent piping and support and installation shall withstand the effects of earthquake motions determined according to SEI/ASCE 7 and with the requirements specified in Section 230548 "Vibration and Seismic Controls for HVAC."
 - 1. For piping with a seismic importance factor of 1.0 the term "withstand" means "the unit will remain in place without separation of any parts from the device when subjected to the seismic forces specified."
 - 2. For piping with a seismic importance factor of 1.5 the term "withstand" means "the unit will remain in place without separation of any parts from the device when subjected to the seismic forces specified and the unit will be fully operational after the seismic event."

1.5 ACTION SUBMITTALS

- A. Product Data: For each type of product indicated.

1.6 INFORMATIONAL SUBMITTALS

- A. Seismic Qualification Certificates: For waste and vent piping, accessories, and components, from manufacturer.
 - 1. Basis for Certification: Indicate whether withstand certification is based on actual test of assembled components or on calculation.
 - 2. Detailed description of piping anchorage devices on which the certification is based and their installation requirements.
- B. Field quality-control reports.

1.7 QUALITY ASSURANCE

- A. Piping materials shall bear label, stamp, or other markings of specified testing agency.
- B. Comply with NSF/ANSI 14, "Plastics Piping Systems Components and Related Materials," for plastic piping components. Include marking with "NSF-dwv" for plastic drain, waste, and vent piping; "NSF-sewer" for plastic sewer piping; "NSF-drain" for plastic drain piping, and "NSF-tubular" for plastic continuous waste piping.

1.8 PROJECT CONDITIONS

- A. Interruption of Existing Sanitary Waste Service: Do not interrupt service to facilities occupied by Owner or others unless permitted under the following conditions and then only after arranging to provide temporary service according to requirements indicated:
 - 1. Notify Construction Manager no fewer than two days in advance of proposed interruption of sanitary waste service.

PART 2 - PRODUCTS

2.1 PIPING MATERIALS

- A. Comply with requirements in "Piping Schedule" Article for applications of pipe, tube, fitting materials, and joining methods for specific services, service locations, and pipe sizes.

2.2 HUBLESS, CAST-IRON SOIL PIPE AND FITTINGS

- A. Pipe and Fittings: All cast-iron waste, vent and sewer pipe and fittings shall conform to the requirements of CISPI Standard 301 and ASTM A 888. All products shall be marked with the collective trademark of the Cast Soil Pipe Institute and shall be listed by NSF International or receive prior approval of the engineer. All cast-iron pipe and fittings shall be American made and tested. Non-compliant import cast-iron products will not be permitted. Any non-compliant cast-iron product installed by the contractor on this project will be replaced at the contractor's expense and shall include all repairs, patching, painting and other incidental work required to return the project to its pre-remediation state.
 - 1. Manufacturers: Subject to compliance with requirements, provide products by one of the following:

- a. AB&I Foundry
- b. Charlotte Pipe
- c. Tyler Pipe

B. CISPI, Hubless-Piping Couplings:

1. Manufacturers: Subject to compliance with requirements, provide products by one of the following:
 - a. ANACO.
 - b. Ideal
 - c. Mission Rubber Company; a division of MCP Industries, Inc.
 - d. Tyler Pipe.
2. Standards: ASTM C 1277 and CISPI 310.
3. Description: Stainless-steel corrugated shield with stainless-steel bands and tightening devices; and ASTM C 564, rubber sleeve with integral, center pipe stop.
4. Listing: Couplings shall be listed by NSF International. Each coupling shall be embossed with the NSF seal.

C. Heavy-Duty, Hubless-Piping Couplings:

1. Manufacturers: Subject to compliance with requirements, provide products by one of the following:
 - a. Husky SD 4000.
 - b. Clamp-All Corp HI-TORQ 125.
2. Standards: ASTM C 1277 and ASTM C 1540.
3. Description: Stainless-steel shield with stainless-steel bands and tightening devices; and ASTM C 564, rubber sleeve with integral, center pipe stop.

PART 3 - EXECUTION

3.1 PIPING INSTALLATION

- A. Drawing plans, schematics, and diagrams indicate general location and arrangement of piping systems. Indicated locations and arrangements were used to size pipe and calculate friction loss, expansion, pump sizing, and other design considerations. Install piping as indicated unless deviations to layout are approved on coordination drawings.
- B. Install piping in concealed locations unless otherwise indicated and except in equipment rooms and service areas.
- C. Install piping indicated to be exposed and piping in equipment rooms and service areas at right angles or parallel to building walls. Diagonal runs are prohibited unless specifically indicated otherwise.
- D. Install piping above accessible ceilings to allow sufficient space for ceiling panel removal.
- E. Install piping to permit valve servicing.
- F. Install piping at indicated slopes.

- G. Install piping free of sags and bends.
- H. Install fittings for changes in direction and branch connections.
- I. Install piping to allow application of insulation.
- J. Install seismic restraints on piping. Comply with SEI/ASCE 7 and with requirements for seismic-restraint devices specified in Division 22 Section "Vibration and Seismic Controls for Plumbing Piping and Equipment."
- K. Make changes in direction for soil and waste drainage and vent piping using appropriate branches, bends, and long-sweep bends. Sanitary tees and short-sweep 1/4 bends may be used on vertical stacks if change in direction of flow is from horizontal to vertical. Use long-turn, double Y-branch and 1/8-bend fittings if two fixtures are installed back to back or side by side with common drain pipe. Straight tees, elbows, and crosses may be used on vent lines. Do not change direction of flow more than 90 degrees. Use proper size of standard increasers and reducers if pipes of different sizes are connected. Reducing size of drainage piping in direction of flow is prohibited.
- L. Lay buried building drainage piping beginning at low point of each system. Install true to grades and alignment indicated, with unbroken continuity of invert.
- M. Install soil and waste drainage and vent piping at the following minimum slopes unless otherwise indicated:
 - 1. Building Sanitary Drain: 2 percent downward in direction of flow for piping.
 - 2. Horizontal Sanitary Drainage Piping: 2 percent downward in direction of flow.
 - 3. Vent Piping: 1 percent down toward vertical fixture vent or toward vent stack.
- N. Install cast-iron soil piping according to CISPI's "Cast Iron Soil Pipe and Fittings Handbook," Chapter IV, "Installation of Cast Iron Soil Pipe and Fittings."
 - 1. Install encasement on underground piping according to ASTM A 674 or AWWA C105/A 21.5.
- O. Install engineered soil and waste drainage and vent piping systems as follows:
 - 1. Combination Waste and Vent: Comply with standards of authorities having jurisdiction.
- P. Plumbing Specialties:
 - 1. Install cleanouts at grade and extend to where building sanitary drains connect to building sanitary sewers in sanitary drainage gravity-flow piping. Install cleanout fitting with closure plug inside the building in sanitary drainage force-main piping. Comply with requirements for cleanouts specified in Division 22 Section "Sanitary Waste Piping Specialties."
 - 2. Install drains in sanitary drainage gravity-flow piping. Comply with requirements for drains specified in Division 22 Section "Sanitary Waste Piping Specialties."
 - 3. Install cleanout fitting with closure plug inside the building in sanitary force-main piping.
- Q. Do not enclose, cover, or put piping into operation until it is inspected and approved by authorities having jurisdiction.
- R. Install sleeves for piping penetrations of walls, ceilings, and floors. Comply with requirements for sleeves specified in Division 22 Section "Sleeves and Sleeve Seals for Plumbing Piping."

- S. Install sleeve seals for piping penetrations of concrete walls and slabs. Comply with requirements for sleeve seals specified in Division 22 Section "Sleeves and Sleeve Seals for Plumbing Piping."
- T. Install escutcheons for piping penetrations of walls, ceilings, and floors. Comply with requirements for escutcheons specified in Division 22 Section "Escutcheons for Plumbing Piping."
- U. Vents shall extend full size through roof and shall project minimum 18-in above the roof.

3.2 JOINT CONSTRUCTION

- A. Join hubless, cast-iron soil piping according to CISPI 310 and CISPI's "Cast Iron Soil Pipe and Fittings Handbook" for hubless-piping coupling joints.
- B. Plastic, Nonpressure-Piping, Solvent-Cement Joints: Clean and dry joining surfaces. Join pipe and fittings according to the following:
 - 1. Comply with ASTM F 402 for safe-handling practice of cleaners, primers, and solvent cements.
 - 2. PVC Piping: Join according to ASTM D 2855 and ASTM D 2665 Appendixes.

3.3 HANGER AND SUPPORT INSTALLATION

- A. Comply with requirements for seismic-restraint devices specified in Division 22 Section "Vibration and Seismic Controls for Plumbing Piping and Equipment."
- B. Comply with requirements for pipe hanger and support devices and installation specified in Division 22 Section "Hangers and Supports for Plumbing Piping and Equipment."
 - 1. Install carbon-steel pipe hangers for horizontal piping in noncorrosive environments.
 - 2. Install stainless-steel pipe hangers for horizontal piping in corrosive environments.
 - 3. Install carbon-steel pipe support clamps for vertical piping in noncorrosive environments.
 - 4. Install stainless-steel pipe support clamps for vertical piping in corrosive environments.
 - 5. Vertical Piping: MSS Type 8 or Type 42, clamps.
 - 6. Install individual, straight, horizontal piping runs:
 - a. 100 Feet and Less: MSS Type 1, adjustable, steel clevis hangers.
 - b. Longer Than 100 Feet: MSS Type 43, adjustable roller hangers.
 - c. Longer Than 100 Feet if Indicated: MSS Type 49, spring cushion rolls.
 - 7. Multiple, Straight, Horizontal Piping Runs 100 Feet or Longer: MSS Type 44, pipe rolls. Support pipe rolls on trapeze.
 - 8. Base of Vertical Piping: MSS Type 52, spring hangers.
- C. Support horizontal piping and tubing within 12 inches of each fitting and coupling or valve and coupling.
- D. Support vertical piping and tubing at base and at each floor.
- E. Rod diameter may be reduced one size for double-rod hangers, with 3/8-inch minimum rods.

- F. Install hangers for cast-iron soil piping with the following maximum horizontal spacing and minimum rod diameters:
 - 1. NPS 1-1/2 and NPS 2: 60 inches with 3/8-inch rod.
 - 2. NPS 3: 60 inches with 1/2-inch rod.
 - 3. NPS 4 and NPS 5: 60 inches with 5/8-inch rod.
 - 4. NPS 6 and NPS 8: 60 inches with 3/4-inch rod.
 - 5. NPS 10 and NPS 12: 60 inches with 7/8-inch rod.
 - 6. Spacing for 10-foot lengths may be increased to 10 feet. Spacing for fittings is limited to 60 inches.
- G. Install supports for vertical cast-iron soil piping every 15 feet.
- H. Support piping and tubing not listed above according to MSS SP-69 and manufacturer's written instructions.

3.4 CONNECTIONS

- A. Drawings indicate general arrangement of piping, fittings, and specialties.
- B. Connect soil and waste piping to exterior sanitary sewerage piping. Use transition fitting to join dissimilar piping materials.
- C. Connect drainage and vent piping to the following:
 - 1. Plumbing Fixtures: Connect drainage piping in sizes indicated, but not smaller than required by plumbing code.
 - 2. Plumbing Fixtures and Equipment: Connect atmospheric vent piping in sizes indicated, but not smaller than required by authorities having jurisdiction.
 - 3. Plumbing Specialties: Connect drainage and vent piping in sizes indicated, but not smaller than required by plumbing code.
 - 4. Install test tees (wall cleanouts) in conductors near floor and floor cleanouts with cover flush with floor.
 - 5. Comply with requirements for cleanouts and drains specified in Division 22 Section "Sanitary Waste Piping Specialties."
 - 6. Equipment: Connect drainage piping as indicated. Provide shutoff valve if indicated and union for each connection. Use flanges instead of unions for connections NPS 2-1/2 and larger.
- D. Where installing piping adjacent to equipment, allow space for service and maintenance of equipment.
- E. Make fixture and equipment connections according to the following unless otherwise indicated:
 - 1. Install unions, in piping NPS 2 and smaller, adjacent to each valve and at final connection to each piece of equipment.
 - 2. Install flanges, in piping NPS 2-1/2 and larger, adjacent to flanged valves and at final connection to each piece of equipment.

3.5 IDENTIFICATION

- A. Identify exposed sanitary waste and vent piping. Comply with requirements for identification specified in Division 22 Section "Identification for Plumbing Piping and Equipment."

3.6 FIELD QUALITY CONTROL

- A. During installation, notify authorities having jurisdiction at least 24 hours before inspection must be made. Perform tests specified below in presence of authorities having jurisdiction.
 - 1. Roughing-in Inspection: Arrange for inspection of piping before concealing or closing-in after roughing-in and before setting fixtures.
 - 2. Final Inspection: Arrange for final inspection by authorities having jurisdiction to observe tests specified below and to ensure compliance with requirements.
- B. Reinspection: If authorities having jurisdiction find that piping will not pass test or inspection, make required corrections and arrange for reinspection.
- C. Reports: Prepare inspection reports and have them signed by authorities having jurisdiction.
- D. Test sanitary drainage and vent piping according to procedures of authorities having jurisdiction or, in absence of published procedures, as follows:
 - 1. Test for leaks and defects in new piping and parts of existing piping that have been altered, extended, or repaired. If testing is performed in segments, submit separate report for each test, complete with diagram of portion of piping tested.
 - 2. Leave uncovered and unconcealed new, altered, extended, or replaced drainage and vent piping until it has been tested and approved. Expose work that was covered or concealed before it was tested.
 - 3. Roughing-in Plumbing Test Procedure: Test drainage and vent piping except outside leaders on completion of roughing-in. Close openings in piping system and fill with water to point of overflow, but not less than 10-foot head of water. From 15 minutes before inspection starts to completion of inspection, water level must not drop. Inspect joints for leaks.
 - 4. Finished Plumbing Test Procedure: After plumbing fixtures have been set and traps filled with water, test connections and prove they are gastight and watertight. Plug vent-stack openings on roof and building drains where they leave building. Introduce air into piping system equal to pressure of 1-inch wg. Use U-tube or manometer inserted in trap of water closet to measure this pressure. Air pressure must remain constant without introducing additional air throughout period of inspection. Inspect plumbing fixture connections for gas and water leaks.
 - 5. Repair leaks and defects with new materials and retest piping, or portion thereof, until satisfactory results are obtained.
 - 6. Prepare reports for tests and required corrective action.

3.7 CLEANING AND PROTECTION

- A. Clean interior of piping. Remove dirt and debris as work progresses.
- B. Protect drains during remainder of construction period to avoid clogging with dirt and debris and to prevent damage from traffic and construction work.
- C. Place plugs in ends of uncompleted piping at end of day and when work stops.

3.8 PIPING SCHEDULE

- A. Flanges and unions may be used on aboveground pressure piping unless otherwise indicated.

- B. Aboveground, soil and waste piping NPS 3 and smaller shall be the following:
 - 1. Hubless, cast-iron soil pipe and fittings CISPI hubless-piping couplings; and coupled joints.
 - 2. Dissimilar Pipe-Material Couplings: Shielded, nonpressure transition couplings.
- C. Aboveground, soil and waste piping NPS 4 and larger shall be the following:
 - 1. Hubless, cast-iron soil pipe and fittings heavy-duty hubless-piping couplings; and coupled joints.
 - 2. Dissimilar Pipe-Material Couplings: Shielded, nonpressure transition couplings.
- D. Aboveground, vent piping NPS 3 and smaller shall be the following:
 - 1. Hubless, cast-iron soil pipe and fittings CISPI hubless-piping couplings; and coupled joints.
 - 2. Dissimilar Pipe-Material Couplings: Shielded, nonpressure transition couplings.
- E. Aboveground, vent piping NPS 4 and larger shall be the following:
 - 1. Hubless, cast-iron soil pipe and fittings CISPI hubless-piping couplings; and coupled joints.
 - 2. Dissimilar Pipe-Material Couplings: Unshielded, nonpressure transition couplings.
- F. Dissimilar Pipe-Material Couplings: Shielded, nonpressure transition couplings.

END OF SECTION 22 1316

SECTION 22 1319

SANITARY WASTE PIPING SPECIALTIES

PART 1 - GENERAL

1.1 RELATED DOCUMENTS

- A. Drawings and general provisions of the Contract, including General and Supplementary Conditions and Division 01 Specification Sections, apply to this Section.

1.2 SUMMARY

- A. This Section includes the following sanitary drainage piping specialties:
 - 1. Cleanouts.
 - 2. Floor drains.
 - 3. Roof flashing assemblies.
 - 4. Through-penetration firestop assemblies.
 - 5. Miscellaneous sanitary drainage piping specialties.
 - 6. Flashing materials.
- B. Related Sections include the following:
 - 1. Division 22 Section "Storm Drainage Piping Specialties" for trench drains for storm water, channel drainage systems for storm water, roof drains, and catch basins.

1.3 SEISMIC REQUIREMENTS

- A. Seismic Performance: Plumbing equipment, hangers and supports shall withstand the effects of earthquake motions determined according to SEI/ASCE 7 and with the requirements specified in Section 220548 "Vibration and Seismic Controls for Plumbing Piping and Equipment.

1.4 DEFINITIONS

- A. FOG: Fats, oils, and greases.
- B. FRP: Fiberglass-reinforced plastic.
- C. HDPE: High-density polyethylene plastic.
- D. PE: Polyethylene plastic.
- E. PP: Polypropylene plastic.
- F. PVC: Polyvinyl chloride plastic.

1.5 SUBMITTALS

- A. Product Data: For each type of product indicated.
- B. Field quality-control test reports.

- C. Operation and Maintenance Data: For drainage piping specialties to include in emergency, operation, and maintenance manuals.

1.6 QUALITY ASSURANCE

- A. Drainage piping specialties shall bear label, stamp, or other markings of specified testing agency.
- B. Comply with NSF 14, "Plastics Piping Components and Related Materials," for plastic sanitary piping specialty components.

1.7 COORDINATION

- A. Coordinate size and location of concrete bases. Cast anchor-bolt inserts into bases. Concrete, reinforcement, and formwork requirements are specified in Division 03.
- B. Coordinate size and location of roof penetrations.

PART 2 - PRODUCTS

2.1 CLEANOUTS

A. Exposed Metal Cleanouts:

1. Manufacturers: Subject to compliance with requirements, provide products by one of the following:
 - a. Josam Company; Josam Div.
 - b. MIFAB, Inc.
 - c. Smith, Jay R. Mfg. Co.; Division of Smith Industries, Inc.
 - d. Tyler Pipe; Wade Div.
 - e. Watts Drainage Products Inc.
 - f. Zurn Plumbing Products Group; Specification Drainage Operation.
2. Standard: ASME A112.36.2M for cast iron for cleanout test tee.
3. Size: Same as connected drainage piping
4. Body Material: Hubless, cast-iron soil pipe test tee as required to match connected piping.
5. Closure: Countersunk, brass plug.
6. Closure Plug Size: Same as or not more than one size smaller than cleanout size.
7. Closure: Stainless-steel plug with seal.

B. Metal Floor Cleanouts:

1. Manufacturers: Subject to compliance with requirements, provide products by one of the following:
 - a. Josam Company; Josam Div.
 - b. Oatey.
 - c. Smith, Jay R. Mfg. Co.; Division of Smith Industries, Inc.
 - d. Tyler Pipe; Wade Div.
 - e. Watts Drainage Products Inc.
 - f. Zurn Plumbing Products Group; Light Commercial Operation.
 - g. Zurn Plumbing Products Group; Specification Drainage Operation.

2. Standard: ASME A112.36.2M for adjustable housing cleanout.
3. Size: Same as connected branch.
4. Type: Adjustable housing.
5. Body or Ferrule: Cast iron.
6. Clamping Device: Required.
7. Outlet Connection: Inside call.
8. Closure: Brass plug with tapered threads.
9. Adjustable Housing Material: Cast iron with threads.
10. Frame and Cover Material and Finish: Nickel-bronze, copper alloy.
11. Frame and Cover Shape: Round.
12. Top Loading Classification: Heavy Duty.
13. Riser: ASTM A 74, Service class, cast-iron drainage pipe fitting and riser to cleanout.
14. Standard: ASME A112.3.1.
15. Size: Same as connected branch.
16. Housing: Stainless steel.
17. Closure: Stainless steel with seal.
18. Riser: Stainless-steel drainage pipe fitting to cleanout.

C. Cast-Iron Wall Cleanouts:

1. Manufacturers: Subject to compliance with requirements, provide products by one of the following:
 - a. Josam Company; Josam Div.
 - b. MIFAB, Inc.
 - c. Smith, Jay R. Mfg. Co.; Division of Smith Industries, Inc.
 - d. Tyler Pipe; Wade Div.
 - e. Watts Drainage Products Inc.
 - f. Zurn Plumbing Products Group; Specification Drainage Operation.
2. Standard: ASME A112.36.2M. Include wall access.
3. Size: Same as connected drainage piping.
4. Body: Hub-and-spigot, cast-iron soil pipe T-branch as required to match connected piping.
5. Closure: Countersunk, brass plug.
6. Closure Plug Size: Same as or not more than one size smaller than cleanout size.
7. Wall Access: Round, flat, chrome-plated brass or stainless-steel cover plate with screw.
8. Wall Access: Round, stainless-steel wall-installation frame and cover.

2.2 FLOOR DRAINS

A. Cast-Iron Floor Drains:

1. Manufacturers: Subject to compliance with requirements, provide products by one of the following:
 - a. Josam Company; Josam Div.
 - b. MIFAB, Inc.
 - c. Smith, Jay R. Mfg. Co.; Division of Smith Industries, Inc.
 - d. Tyler Pipe; Wade Div.
 - e. Watts Drainage Products Inc.
 - f. Zurn Plumbing Products Group; Specification Drainage Operation.
2. Standard: ASME A112.6.3.
3. Body Material: Gray iron.
4. Seepage Flange: Required.
5. Anchor Flange: Not required.
6. Outlet: Bottom.

7. Trap Material: Cast iron>.
8. Trap Pattern: Deep-seal P-trap>.
9. Trap Features: Trap-seal primer valve drain connection>.

2.3 THROUGH-PENETRATION FIRESTOP ASSEMBLIES

A. Through-Penetration Firestop Assemblies:

1. Available Manufacturers: Subject to compliance with requirements, manufacturers offering products that may be incorporated into the Work include, but are not limited to, the following:
2. Manufacturers: Subject to compliance with requirements, provide products by one of the following:
 - a. ProSet Systems Inc.
3. Standard: UL 1479 assembly of sleeve and stack fitting with firestopping plug.
4. Size: Same as connected soil, waste, or vent stack.
5. Sleeve: Molded PVC plastic, of length to match slab thickness and with integral nailing flange on one end for installation in cast-in-place concrete slabs.
6. Stack Fitting: ASTM A 48/A 48M, gray-iron, hubless-pattern, wye branch with neoprene O-ring at base and gray-iron plug in thermal-release harness. Include PVC protective cap for plug.
7. Special Coating: Corrosion resistant on interior of fittings.

2.4 MISCELLANEOUS SANITARY DRAINAGE PIPING SPECIALTIES

A. Deep-Seal Traps:

1. Description: Cast-iron or bronze casting, with inlet and outlet matching connected piping and cleanout trap-seal primer valve connection.
2. Size: Same as connected waste piping.
 - a. NPS 2: 4-inch- minimum water seal.
 - b. NPS 2-1/2 and Larger: 5-inch- minimum water seal.

B. Air-Gap Fittings:

1. Standard: ASME A112.1.2, for fitting designed to ensure fixed, positive air gap between installed inlet and outlet piping.
2. Body: Bronze or cast iron.
3. Inlet: Opening in top of body.
4. Outlet: Larger than inlet.
5. Size: Same as connected waste piping and with inlet large enough for associated indirect waste piping.

C. Sleeve Flashing Device:

1. Description: Manufactured, cast-iron fitting, with clamping device, that forms sleeve for pipe floor penetrations of floor membrane. Include galvanized-steel pipe extension in top of fitting that will extend 1 inch > above finished floor and galvanized-steel pipe extension in bottom of fitting that will extend through floor slab.
2. Size: As required for close fit to riser or stack piping.

D. Stack Flashing Fittings:

1. Description: Counterflashing-type, cast-iron fitting, with bottom recess for terminating roof membrane, and with threaded or hub top for extending vent pipe.
2. Size: Same as connected stack vent or vent stack.

2.5 FLASHING MATERIALS

- A. Lead Sheet: ASTM B 749, Type L51121, copper bearing, with the following minimum weights and thicknesses, unless otherwise indicated:
 1. General Use: 4.0-lb/sq. ft., 0.0625-inch thickness.
 2. Vent Pipe Flashing: 3.0-lb/sq. ft., 0.0469-inch thickness.
 3. Burning: 6-lb/sq. ft., 0.0938-inch thickness.
- B. Elastic Membrane Sheet: ASTM D 4068, flexible, chlorinated polyethylene, 40-mil minimum thickness.
- C. Fasteners: Metal compatible with material and substrate being fastened.
- D. Metal Accessories: Sheet metal strips, clamps, anchoring devices, and similar accessory units required for installation; matching or compatible with material being installed.
- E. Bituminous Coating: SSPC-Paint 12, solvent-type, bituminous mastic.

PART 3 - EXECUTION

3.1 INSTALLATION

- A. Comply with requirements for seismic-restraint devices in Section 220548 "Vibration and Seismic Controls for Plumbing Piping and Equipment."
- B. Refer to Division 22 Section "Common Work Results for Plumbing" for piping joining materials, joint construction, and basic installation requirements.
- C. Install cleanouts in aboveground piping and building drain piping according to the following, unless otherwise indicated:
 1. Size same as drainage piping up to NPS 4. Use NPS 4 for larger drainage piping unless larger cleanout is indicated.
 2. Locate at each change in direction of piping greater than 45 degrees.
 3. Locate at minimum intervals of 50 feet for piping NPS 4 and smaller and 100 feet for larger piping.
 4. Locate at base of each vertical soil and waste stack.
- D. For floor cleanouts for piping below floors, install cleanout deck plates with top flush with finished floor.
- E. For cleanouts located in concealed piping, install cleanout wall access covers, of types indicated, with frame and cover flush with finished wall.
- F. Install floor drains at low points of surface areas to be drained. Set grates of drains flush with finished floor, unless otherwise indicated.
 1. Position floor drains for easy access and maintenance.
 2. Set floor drains below elevation of surrounding finished floor to allow floor drainage. Set with grates depressed according to the following drainage area radii:

- a. Radius, 30 Inches or Less: Equivalent to 1 percent slope, but not less than 1/4-inch total depression.
 - b. Radius, 30 to 60 Inches: Equivalent to 1 percent slope.
 - c. Radius, 60 Inches or Larger: Equivalent to 1 percent slope, but not greater than 1-inch total depression.
- 3. Install floor-drain flashing collar or flange so no leakage occurs between drain and adjoining flooring. Maintain integrity of waterproof membranes where penetrated.
 - 4. Install individual traps for floor drains connected to sanitary building drain, unless otherwise indicated.
- G. Install deep-seal traps on all floor drains and other waste outlets, if indicated.
 - H. Install air-gap fittings on draining-type backflow preventers and on indirect-waste piping discharge into sanitary drainage system.
 - I. Install sleeve flashing device with each riser and stack passing through floors with waterproof membrane.
 - J. Install wood-blocking reinforcement for wall-mounting-type specialties.
 - K. Install traps on plumbing specialty drain outlets. Omit traps on indirect wastes unless trap is indicated.
 - L. Install escutcheons at wall, floor, and ceiling penetrations in exposed finished locations and within cabinets and millwork. Use deep-pattern escutcheons if required to conceal protruding pipe fittings.

3.2 CONNECTIONS

- A. Piping installation requirements are specified in other Division 22 Sections. Drawings indicate general arrangement of piping, fittings, and specialties.
- B. Install piping adjacent to equipment to allow service and maintenance.

3.3 FLASHING INSTALLATION

- A. Fabricate flashing from single piece unless large pans, sumps, or other drainage shapes are required. Join flashing according to the following if required:
 - 1. Lead Sheets: Burn joints of lead sheets 6.0-lb/sq. ft., 0.0938-inch thickness or thicker. Solder joints of lead sheets 4.0-lb/sq. ft., 0.0625-inch thickness or thinner.
- B. Install sheet flashing on pipes, sleeves, and specialties passing through or embedded in floors and roofs with waterproof membrane.
 - 1. Pipe Flashing: Sleeve type, matching pipe size, with minimum length of 10 inches, and skirt or flange extending at least 8 inches around pipe.
 - 2. Sleeve Flashing: Flat sheet, with skirt or flange extending at least 8 inches around sleeve.
 - 3. Embedded Specialty Flashing: Flat sheet, with skirt or flange extending at least 8 inches around specialty.
- C. Set flashing on floors and roofs in solid coating of bituminous cement.
- D. Secure flashing into sleeve and specialty clamping ring or device.

- E. Install flashing for piping passing through roofs with counterflashing or commercially made flashing fittings, according to Division 07 Section "Sheet Metal Flashing and Trim."
- F. Extend flashing up vent pipe passing through roofs and turn down into pipe, or secure flashing into cast-iron sleeve having calking recess.
- G. Fabricate and install flashing and pans, sumps, and other drainage shapes.

3.4 FIELD QUALITY CONTROL

- A. Perform tests and inspections and prepare test reports.
- B. Tests and Inspections:
 - 1. Leak Test: After installation, charge system and test for leaks. Repair leaks and retest until no leaks exist.
 - 2. Test and adjust controls and safeties. Replace damaged and malfunctioning controls and equipment.

3.5 PROTECTION

- A. Protect drains during remainder of construction period to avoid clogging with dirt or debris and to prevent damage from traffic or construction work.
- B. Place plugs in ends of uncompleted piping at end of each day or when work stops.

END OF SECTION 22 1319

THIS PAGE LEFT BLANK INTENTIONALLY

SECTION 22 6113

COMPRESSED-AIR PIPING FOR LABORATORY AND HEALTHCARE FACILITIES

PART 1 - GENERAL

1.1 RELATED DOCUMENTS

- A. Drawings and general provisions of the Contract, including General and Supplementary Conditions and Division 01 Specification Sections, apply to this Section.

1.2 SUMMARY

- A. Section Includes:
 - 1. Compressed-air piping, designated "compressed air."

1.3 DEFINITIONS

- A. Medical compressed-air piping systems include medical air, compressed air and, instrument air.

1.4 ACTION SUBMITTALS

- A. Product Data: For each type of product.

1.5 INFORMATIONAL SUBMITTALS

- A. Qualification Data: For Installer and testing agency.
- B. Brazing certificates.
- C. Field quality-control reports.

1.6 CLOSEOUT SUBMITTALS

- A. Operation and Maintenance Data: For compressed-air piping specialties to include in emergency, operation, and maintenance manuals.

1.7 QUALITY ASSURANCE

- A. Installer Qualifications:
 - 1. Medical Air Piping Systems for Healthcare Facilities: According to ASSE Standard #6010 for medical-gas-system installers.
 - 2. Shape-Memory-Metal Coupling Joints: An authorized representative who is trained and approved by manufacturer.
- B. Brazing: Qualify processes and operators according to ASME Boiler and Pressure Vessel Code, Section IX, "Welding and Brazing Qualifications"; or AWS B2.2, "Standard for Brazing Procedure and Performance Qualification."

PART 2 - PRODUCTS

2.1 SYSTEM DESCRIPTION

- A. Compressed air operating at 100 psig.

2.2 PIPES, TUBES, AND FITTINGS

- A. Comply with ASME B31.9, "Building Services Piping," for compressed air piping operating at 150 psig or less.
- B. Copper Medical Gas Tube: ASTM B 819, Type K and Type L, seamless, drawn temper, that has been manufacturer cleaned, purged, and sealed for medical gas service or according to CGA G-4.1 for oxygen service. Include standard color marking "OXY," "MED," "OXY/MED," "OXY/ACR," or "ACR/MED" in green for Type K tube and in blue for Type L tube.
- C. Wrought-Copper Fittings: ASME B16.22, solder-joint pressure type that has been manufacturer cleaned, purged, and bagged for oxygen service according to CGA G-4.1.
- D. Copper Unions: ASME B16.22 or MSS SP-123, wrought-copper or cast-copper alloy.
- E. Cast-Copper-Alloy Flanges: ASME B16.24, Class 150.
 - 1. Pipe-Flange Gasket Materials: ASME B16.21, nonmetallic, flat, asbestos free, 1/8-inch maximum thickness, full-face type.
 - 2. Flange Bolts and Nuts: ASME B18.2.1, carbon steel.
- F. Flexible Pipe Connectors:
 - 1. Manufacturers: Subject to compliance with requirements, provide products by one of the following:
 - 2. Basis-of-Design Product: Subject to compliance with requirements, provide product by one of the following:
 - a. Flex-Hose Co., Inc.
 - b. Flexicraft Industries.
 - c. Hyspan Precision Products, Inc.
 - d. Mercer Gasket & Shim, Inc.
 - e. Metraflex Company (The).
 - f. Proco Products, Inc.
 - g. Unaflex.
 - h. Universal Metal Hose; a Hyspan Co.
 - 3. Description: Corrugated-bronze tubing with bronze wire-braid covering and ends brazed to inner tubing.
 - a. Working-Pressure Rating: 200 psig minimum.
 - b. End Connections: Plain-end copper tube.

2.3 JOINING MATERIALS

- A. Brazing Filler Metals: AWS A5.8/A5.8M, BCuP Series, copper-phosphorus alloys.
- B. Threaded-Joint Tape: PTFE.

2.4 VALVES

- A. General Requirements for Valves: Manufacturer cleaned, purged, and bagged according to CGA G-4.1 for oxygen service.
- B. Ball Valves:
1. Manufacturers: Subject to compliance with requirements, provide products by one of the following:
 2. Basis-of-Design Product: Subject to compliance with requirements, provide product by one of the following:
 - a. Allied Healthcare Products Inc.; Chemetron Division.
 - b. Amico Corporation.
 - c. BeaconMedaes.
 - d. Conbraco Industries, Inc.
 - e. Marwin Valve; a division of Richards Industries.
 - f. NIBCO INC.
 - g. Ohio Medical Corporation.
 - h. Tri-Tech Medical Inc.
 - i. Patton's Medical
 3. Standard: MSS SP-110.
 4. Description: Three-piece body, brass or bronze.
 5. Pressure Rating: 300 psig minimum.
 6. Ball: Full-port, chrome-plated brass.
 7. Seats: PTFE or TFE.
 8. Handle: Lever type with locking device.
 9. Stem: Blowout proof with PTFE or TFE seal.
 10. Ends: Manufacturer-installed ASTM B 819, copper-tube extensions.
- C. Check Valves:
1. Manufacturers: Subject to compliance with requirements provide products by one of the following:
 2. Basis-of-Design Product: Subject to compliance with requirements, provide product by one of the following:
 - a. Allied Healthcare Products Inc.; Chemetron Division.
 - b. Amico Corporation.
 - c. BeaconMedaes.
 - d. Conbraco Industries, Inc.
 - e. Ohio Medical Corporation.
 - f. Patton's Medical
 - g. Tri-Tech Medical Inc.
 3. Description: In-line pattern, bronze.
 4. Pressure Rating: 300 psig minimum.
 5. Operation: Spring loaded.
 6. Ends: Manufacturer-installed ASTM B 819, copper-tube extensions.
- D. Pressure Regulators:
1. Bronze body and trim.
 2. Spring-loaded, diaphragm-operated, relieving type.
 3. Manual pressure-setting adjustment.
 4. Rated for 250-psig minimum inlet pressure.
 5. Capable of controlling delivered air pressure within 0.5 psig for each 10-psig inlet pressure.

2.5 NITROGEN

- A. Comply with USP 32 - NF 27 for oil-free dry nitrogen.

PART 3 - EXECUTION

3.1 PREPARATION

- A. Cleaning of Medical Gas Tubing: If manufacturer-cleaned and -capped fittings or tubing is not available or if precleaned fittings or tubing must be recleaned because of exposure, have supplier or separate agency acceptable to authorities having jurisdiction perform the following procedures:
 - 1. Clean medical gas tube and fittings, valves, gages, and other components of oil, grease, and other readily oxidizable materials as required for oxygen service according to CGA G-4.1.
 - 2. Wash medical gas tubing and components in hot, alkaline-cleaner-water solution of sodium carbonate or trisodium phosphate in proportion of 1 lb of chemical to 3 gal. of water.
 - a. Scrub to ensure complete cleaning.
 - b. Rinse with clean, hot water to remove cleaning solution.

3.2 PIPING INSTALLATION

- A. Drawing plans, schematics, and diagrams indicate general location and arrangement of compressed-air piping. Indicated locations and arrangements were used to size pipe and calculate friction loss, expansion, air-compressor sizing, and other design considerations. Install piping as indicated unless deviations to layout are approved on coordination drawings.
- B. Comply with NFPA 99 for installation of compressed-air piping.
- C. Install piping concealed from view and protected from physical contact by building occupants unless otherwise indicated and except in equipment rooms and service areas.
- D. Install piping indicated to be exposed and piping in equipment rooms and service areas at right angles or parallel to building walls. Diagonal runs are prohibited unless specifically indicated otherwise.
- E. Install piping above accessible ceilings to allow sufficient space for ceiling panel removal and coordinate with other services occupying that space.
- F. Install piping adjacent to equipment and specialties to allow service and maintenance.
- G. Install compressed-air piping with 1 percent slope downward in direction of flow.
- H. Install nipples, unions, special fittings, and valves with pressure ratings same as or higher than system pressure rating used in applications specified in "Piping Schedule" Article unless otherwise indicated.
- I. Install eccentric reducers, if available, where compressed-air piping is reduced in direction of flow, with bottoms of both pipes and reducer fitting flush.
- J. Install branch connections to compressed-air mains from top of main. Provide drain leg and drain trap at end of each main and branch and at low points.

- K. Install piping to permit valve servicing.
- L. Install piping free of sags and bends.
- M. Install fittings for changes in direction and for branch connections.
- N. Piping Restraint Installation: Install seismic restraints on compressed-air piping. Seismic-restraint devices are specified in Section 220548 "Vibration and Seismic Controls for Plumbing Piping and Equipment."
- O. Install unions in copper compressed-air tubing adjacent to each valve and at final connection to each machine, specialty, and piece of equipment.
- P. Install sleeves for piping penetrations of walls, ceilings, and floors. Comply with requirements for sleeves specified in Section 220517 "Sleeves and Sleeve Seals for Plumbing Piping."
- Q. Install escutcheons for piping penetrations of walls, ceilings, and floors. Comply with requirements for escutcheons specified in Section 220518 "Escutcheons for Plumbing Piping."

3.3 VALVE INSTALLATION

- A. Install shutoff valve at each connection to and from compressed-air equipment and specialties.
- B. Install check valves to maintain correct direction of compressed-air flow from compressed-air equipment.
- C. Install pressure regulators on compressed-air piping where reduced pressure is required.

3.4 JOINT CONSTRUCTION

- A. Remove scale, slag, dirt, and debris from outside of cleaned tubing and fittings before assembly.
- B. Threaded Joints: Apply appropriate tape to external pipe threads.
- C. Brazed Joints: Join copper tube and fittings according to CDA's "Copper Tube Handbook," "Brazed Joints" chapter. Continuously purge joint with oil-free dry nitrogen during brazing.
- D. Flanged Joints: Install flange on copper tubes. Use pipe-flange gasket between flanges. Join flanges with gasket and bolts according to ASME B31.9 for bolting procedure.

3.5 HANGER AND SUPPORT INSTALLATION

- A. Comply with requirements in Section 220548 "Vibration and Seismic Controls for Plumbing Piping and Equipment" for seismic-restraint devices.
- B. Comply with requirements in Section 220529 "Hangers and Supports for Plumbing Piping and Equipment" for pipe hanger and support devices.
- C. Vertical Piping: MSS Type 8 or Type 42, clamps.
- D. Individual, Straight, Horizontal Piping Runs:
 1. 100 Feet and Less: MSS Type 1, adjustable, steel, clevis hangers.
 2. Longer Than 100 Feet: MSS Type 43, adjustable, roller hangers.

- E. Multiple, Straight, Horizontal Piping Runs 100 Feet or Longer: MSS Type 44, pipe rolls. Support pipe rolls on trapeze. Comply with requirements in Section 220529 "Hangers and Supports for Plumbing Piping and Equipment" for trapeze hangers.
- F. Base of Vertical Piping: MSS Type 52, spring hangers.
- G. Support horizontal piping within 12 inches of each fitting and coupling.
- H. Rod diameter may be reduced one size for double-rod hangers, with 3/8-inch- minimum rods.
- I. Install hangers for copper tubing with the following maximum horizontal spacing and minimum rod diameters:
 - 1. NPS 1/4: 60 inches with 3/8-inch rod.
 - 2. NPS 3/8 and NPS 1/2: 72 inches with 3/8-inch rod.
 - 3. NPS 3/4: 84 inches with 3/8-inch rod.
 - 4. NPS 1: 96 inches with 3/8-inch rod.
 - 5. NPS 1-1/4: 108 inches with 3/8-inch rod.
 - 6. NPS 1-1/2: 10 feet with 3/8-inch rod.
 - 7. NPS 2: 11 feet with 3/8-inch rod.
 - 8. NPS 2-1/2: 13 feet with 1/2-inch rod.
 - 9. NPS 3: 14 feet with 1/2-inch rod.
 - 10. NPS 3-1/2: 15 feet with 1/2-inch rod.
 - 11. NPS 4: 16 feet with 1/2-inch rod.
- J. Install supports for vertical copper tubing every 10 feet.

3.6 IDENTIFICATION

- A. Install identifying labels and devices for medical compressed-air piping systems according to NFPA 99. Use the following or similar captions and color-coding for piping products where required by NFPA 99:
 - 1. Compressed Air: Black letters on yellow-and-white checkerboard background.

3.7 FIELD QUALITY CONTROL FOR MEDICAL COMPRESSED-AIR PIPING IN HEALTHCARE FACILITIES

- A. Tests and Inspections:
 - 1. Medical Compressed-Air Testing Coordination: Perform tests, inspections, verifications, and certification of medical compressed-air piping systems concurrently with tests, inspections, and certification of medical gas piping and medical vacuum piping systems.
 - 2. Preparation: Perform the following Installer tests according to requirements in NFPA 99 and ASSE Standard #6010:
 - a. Initial blowdown.
 - b. Initial pressure test.
 - c. Cross-connection test.
 - d. Piping purge test.
 - e. Standing pressure test for positive-pressure medical compressed-air piping.
 - f. Repair leaks and retest until no leaks exist.
 - 3. System Verification: Perform the following tests and inspections according to NFPA 99, ASSE Standard #6020, and ASSE Standard #6030:

- a. Standing pressure test.
 - b. Individual-pressurization or pressure-differential cross-connection test.
 - c. Valve test.
 - d. Master and area alarm tests.
 - e. Piping purge test.
 - f. Piping particulate test.
 - g. Piping purity test.
 - h. Final tie-in test.
 - i. Operational pressure test.
 - j. Medical air purity test.
 - k. Verify correct labeling of equipment and components.
4. Testing Certification: Certify that specified tests, inspections, and procedures have been performed and certify report results. Include the following:
- a. Inspections performed.
 - b. Procedures, materials, and gases used.
 - c. Test methods used.
 - d. Results of tests.
- B. Remove and replace components that do not pass tests and inspections and retest as specified above.

3.8 PROTECTION

- A. Protect tubing from damage.
- B. Retain sealing plugs in tubing, fittings, and specialties until installation.
- C. Clean tubing not properly sealed, and where sealing is damaged, according to "Preparation" Article.

3.9 PIPING SCHEDULE

- A. Flanges may be used where connection to flanged equipment is required.
- B. Compressed Air Piping: Type L, copper medical gas tube; wrought-copper fittings; and brazed joints.

3.10 VALVE SCHEDULE

- A. Shutoff Valves: Ball valve with manufacturer-installed ASTM B 819, copper-tube extensions.

END OF SECTION 22 6113

THIS PAGE LEFT BLANK INTENTIONALLY

SECTION 22 6213

VACUUM PIPING FOR LABORATORY AND HEALTHCARE FACILITIES

PART 1 - GENERAL

1.1 RELATED DOCUMENTS

- A. Drawings and general provisions of the Contract, including General and Supplementary Conditions and Division 01 Specification Sections, apply to this Section.

1.2 SUMMARY

- A. Section Includes:
 - 1. Medical-surgical vacuum piping, designated "medical vacuum."
 - 2. Waste anesthetic gas disposal piping, designated "WAGD."
- B. Related Requirements:
 - 1. Section 123570 "Healthcare Casework" for vacuum inlets in healthcare casework.
 - 2. Section 226400 "Medical Gas Alarms" for vacuum piping alarms.

1.3 DEFINITIONS

- A. WAGD: Waste anesthetic gas disposal.
- B. Medical vacuum piping systems include medical vacuum, WAGD, dental vacuum, HVE, and medical laboratory vacuum piping systems.

1.4 ACTION SUBMITTALS

- A. Product Data: For each type of product.

1.5 INFORMATIONAL SUBMITTALS

- A. Qualification Data: For Installer and testing agency.
- B. Material Certificates: Signed by Installer certifying that medical vacuum piping materials comply with requirements in NFPA 99.
- C. Brazing certificates.
- D. Field quality-control reports.

1.6 CLOSEOUT SUBMITTALS

- A. Operation and Maintenance Data: For vacuum piping specialties to include in emergency, operation, and maintenance manuals.

1.7 MAINTENANCE MATERIAL SUBMITTALS

- A. Furnish extra materials that match products installed and that are packaged with protective covering for storage and identified with labels describing contents.
 - 1. Quick-Coupler Service Connections: Furnish complete noninterchangeable medical vacuum suction inlets.
 - a. Medical Vacuum: Equal to 10 percent of amount installed, but no fewer than 10 units.
 - b. WAGD: Equal to 10 percent of amount installed, but no fewer than 10 units.
 - 2. D.I.S.S. Service Connections: Furnish complete medical vacuum suction inlets complying with CGA V-5.
 - a. Medical Vacuum D.I.S.S. No. 1220: Equal to 10 percent of amount installed, but no fewer than 10 units.
 - b. WAGD D.I.S.S. No. 2220: Equal to 10 percent of amount installed, but no fewer than 10 units.

1.8 QUALITY ASSURANCE

- A. Installer Qualifications:
 - 1. Medical Vacuum Piping Systems for Healthcare Facilities: According to ASSE Standard #6010 for medical-gas-system installers.
 - 2. Shape-Memory-Metal Coupling Joints: An authorized representative who is trained and approved by manufacturer.
- B. Testing Agency Qualifications: An independent testing agency, with the experience and capability to conduct the vacuum piping testing indicated, that is a member of the Medical Gas Professional Healthcare Organization or is an NRTL, and that is acceptable to authorities having jurisdiction.
 - 1. Qualify testing personnel according to ASSE Standard #6020 for medical-gas-system inspectors and ASSE Standard #6030 for medical-gas-system verifiers.
- C. Brazing: Qualify processes and operators according to ASME Boiler and Pressure Vessel Code, Section IX, "Welding and Brazing Qualifications"; or AWS B2.2, "Standard for Brazing Procedure and Performance Qualification."

PART 2 - PRODUCTS

2.1 SYSTEM DESCRIPTION

- A. Medical vacuum operating at 15 in. Hg.

- B. WAGD operating at 15 in. Hg.

2.2 PIPES, TUBES, AND FITTINGS

- A. Comply with NFPA 99 for medical vacuum piping materials.
- B. Copper Medical Gas Tube: ASTM B 819, Type L, seamless, drawn temper that has been manufacturer cleaned, purged, and sealed for medical gas service or according to CGA G-4.1 for oxygen service. Include standard color marking "OXY," "MED," "OXY/MED," "OXY/ACR," or "ACR/MED" in blue.
- C. Wrought-Copper Fittings: ASME B16.22, solder-joint pressure type that has been manufacturer cleaned, purged, and sealed for medical gas service or according to CGA G-4.1 for oxygen service.
- D. Copper Unions: ASME B16.22 or MSS SP-123, wrought-copper or cast-copper alloy.
- E. Cast-Copper-Alloy Flanges: ASME B16.24, Class 150.
 - 1. Pipe-Flange Gasket Materials: ASME B16.21, nonmetallic, flat, asbestos-free, 1/8-inch maximum thickness, full-face type.
 - 2. Flange Bolts and Nuts: ASME B18.2.1, carbon steel.
- F. Shape-Memory-Metal Couplings:
 - 1. Manufacturers: Subject to compliance with requirements, provide products by one of the following:
 - 2. Basis-of-Design Product: Subject to compliance with requirements, provide product by one of the following:
 - a. Aerofit, Inc.
 - b. Smart Tap, Inc.
 - 3. Description: Cryogenic compression fitting made of nickel-titanium, shape-memory alloy, and that has been manufacturer cleaned, purged, and sealed for oxygen service according to CGA G-4.1.
- G. Flexible Pipe Connectors:
 - 1. Manufacturers: Subject to compliance with requirements, provide products by one of the following:
 - 2. Basis-of-Design Product: Subject to compliance with requirements, product by one of the following:
 - a. Flex-Hose Co., Inc.
 - b. Flexicraft Industries.
 - c. Hyspan Precision Products, Inc.
 - d. Mercer Gasket & Shim, Inc.
 - e. Metraflex Company (The).
 - f. Proco Products, Inc.
 - g. Unaflex.
 - h. Universal Metal Hose; a Hyspan Co.

3. Description: Corrugated-bronze tubing with bronze wire-braid covering and ends brazed to inner tubing.
 - a. Working-Pressure Rating: 200 psig minimum.
 - b. End Connections: Plain-end copper tube.

2.3 JOINING MATERIALS

- A. Solder Filler Metals: ASTM B 32, lead-free alloys. Include water-flushable flux according to ASTM B 813.
- B. Brazing Filler Metals: AWS A5.8/A5.8M, BCuP Series, copper-phosphorus alloys.
- C. Threaded-Joint Tape: PTFE.

2.4 VALVES

- A. General Requirements for Valves: Manufacturer cleaned, purged, and bagged according to CGA G-4.1 for oxygen service.
 1. Exception: Factory cleaning and bagging are not required for valves for WAGD service.
- B. Zone-Valve Box Assemblies: Box with medical gas valves, tube extensions, and gages.
 1. Zone-Valve Boxes:
 - a. Steel Box with Aluminum Cover:
 - 1) Manufacturers: Subject to compliance with requirements, provide products by one of the following:
 - 2) Basis-of-Design Product: Subject to compliance with requirements, provide product by one of the following:
 - a) Allied Healthcare Products Inc.
 - b) Amico Corporation.
 - c) Ohio Medical Corporation.
 - d) BeaconMedaes
 - b. Description: Formed steel box with cover, anchors for recessed mounting, holes with grommets in box sides for tubing extension protection, and of size for single or multiple valves with pressure gages and in sizes required to permit manual operation of valves. Medical air and medical vacuum tubing, valves, and gages may be incorporated in zone valve boxes for medical gases.
 - 1) Interior Finish: Factory-applied white enamel.
 - 2) Cover Plate: Aluminum with frangible or removable windows.
 - 3) Valve-Box Windows: Clear or tinted transparent plastic with labeling that includes rooms served, according to NFPA 99.
- C. Copper-Alloy Ball Valves:
 1. Manufacturers: Subject to compliance with requirements, provide products by one of the following:

2. Basis-of-Design Product: Subject to compliance with requirements, provide product by one of the following:
 - a. Allied Healthcare Products Inc.; Chemetron Division.
 - b. Amico Corporation.
 - c. BeaconMedaes.
 - d. Conbraco Industries, Inc.
 - e. Marwin Valve; a division of Richards Industries.
 - f. NIBCO INC.
 - g. Ohio Medical Corporation.
 - h. Tri-Tech Medical Inc.
3. Standard: MSS SP-110.
4. Description: Three-piece body, brass or bronze.
5. Pressure Rating: 300 psig minimum.
6. Ball: Full-port, chrome-plated brass.
7. Seats: PTFE or TFE.
8. Handle: Lever type with locking device.
9. Stem: Blowout proof with PTFE or TFE seal.
10. Ends: manufacturer-installed ASTM B 819, copper-tube extensions with pressure gage on one copper-tube extension.

D. Check Valves:

1. Manufacturers: Subject to compliance with requirements, provide products by one of the following:
2. Basis-of-Design Product: Subject to compliance with requirements, provide product by one of the following:
 - a. Allied Healthcare Products Inc.; Chemetron Division.
 - b. Amico Corporation.
 - c. BeaconMedaes.
 - d. Conbraco Industries, Inc.
 - e. Ohio Medical Corporation.
 - f. Tri-Tech Medical Inc.
3. Description: In-line pattern, bronze.
4. Pressure Rating: 300 psig minimum.
5. Operation: Spring loaded.
6. Ends: Manufacturer-installed ASTM B 819, copper-tube extensions.

2.5 MEDICAL VACUUM SERVICE CONNECTIONS

- A. Manufacturers: Subject to compliance with requirements, provide products by one of the following:
- B. Basis-of-Design Product: Subject to compliance with requirements, provide Chemetron compatible product by one of the following:
 1. Allied Healthcare Products Inc.; Chemetron Division.
 2. Amico Corporation.
 3. BeaconMedaes.
 4. Ohio Medical Corporation.
 5. Oxequip Health Industries; a division of Allied Healthcare Products Inc.

6. Tri-Tech Medical Inc.

C. General Requirements for Medical Vacuum Service Connections:

1. Suitable for specific medical vacuum service listed.
2. Include roughing-in assemblies, finishing assemblies, and cover plates.
3. Individual cover plates are not required if service connection is in multiple unit or assembly with cover plate.
4. Recessed-type units made for concealed piping unless otherwise indicated.

D. Roughing-in Assembly:

1. Steel outlet box for recessed mounting and concealed piping.
2. Brass-body inlet block.
3. Seals that will prevent vacuum leakage.
4. ASTM B 819, NPS 3/8 copper outlet tube brazed to valve with service marking and tube-end dust cap.

E. Finishing Assembly:

1. Brass housing with primary check valve.
2. Seals that will prevent vacuum leakage.
3. Cover plate with gas-service label.

F. Quick-Coupler Suction Service Connections:

1. Inlets for medical vacuum and WAGD with noninterchangeable keyed indexing to prevent interchange between services.
2. Constructed to permit one-handed connection and removal of equipment.
3. With positive-locking ring that retains equipment stem in valve during use.

G. D.I.S.S. Suction Service Connections:

1. Inlets complying with CGA V-5.
2. Threaded indexing to prevent interchange between services.
3. Constructed to permit one-handed connection and removal of equipment.
4. Medical Vacuum: CGA V-5, D.I.S.S. No. 1220.
5. WAGD: CGA V-5, D.I.S.S. No. 2220.

H. Vacuum Bottle Brackets: One piece, with pattern and finish matching corresponding service cover plate.

I. Cover Plates:

1. One piece.
2. Aluminum or stainless steel.
3. Permanent, color-coded, identifying label matching corresponding service.

2.6 NITROGEN

A. Comply with USP 32 - NF 27 for oil-free dry nitrogen.

PART 3 - EXECUTION

3.1 PREPARATION

- A. Cleaning of Medical Gas Tubing: If manufacturer-cleaned and -capped fittings or tubing is not available or if precleaned fittings or tubing must be recleaned because of exposure, have supplier or separate agency acceptable to authorities having jurisdiction perform the following procedures:
1. Clean medical gas tube and fittings, valves, gages, and other components of oil, grease, and other readily oxidizable materials as required for oxygen service according to CGA G-4.1.
 2. Wash medical gas tubing and components in hot, alkaline-cleaner-water solution of sodium carbonate or trisodium phosphate in proportion of 1 lb of chemical to 3 gal. of water.
 - a. Scrub to ensure complete cleaning.
 - b. Rinse with clean, hot water to remove cleaning solution.

3.2 PIPING INSTALLATION

- A. Drawing plans, schematics, and diagrams indicate general location and arrangement of vacuum piping. Indicated locations and arrangements were used to size pipe and calculate friction loss, expansion, vacuum producer sizing, and other design considerations. Install piping as indicated unless deviations to layout are approved on coordination drawings.
- B. Comply with NFPA 99 for installation of vacuum piping.
- C. Install piping concealed from view and protected from physical contact by building occupants unless otherwise indicated and except in equipment rooms and service areas.
- D. Install piping indicated to be exposed and piping in equipment rooms and service areas at right angles or parallel to building walls. Diagonal runs are prohibited unless specifically indicated otherwise.
- E. Install piping above accessible ceilings to allow sufficient space for ceiling panel removal and coordinate with other services occupying that space.
- F. Install piping adjacent to equipment and specialties to allow service and maintenance.
- G. Install vacuum piping with 1 percent slope downward in direction of flow.
- H. Install nipples, unions, special fittings, and valves with pressure ratings same as or higher than piping pressure rating used in applications specified in "Piping Schedule" Article unless otherwise indicated.
- I. Install eccentric reducers, if available, where vacuum piping is reduced in direction of flow, with bottoms of both pipes and reducer fitting flush.
- J. Provide drain leg and drain trap at end of each main and branch and at low points.

- K. Install thermometer and vacuum gage on inlet piping to each vacuum producer and on each receiver and separator. Comply with requirements in Section 220519 "Meters and Gages for Plumbing Piping."
- L. Install piping to permit valve servicing.
- M. Install piping free of sags and bends.
- N. Install fittings for changes in direction and for branch connections. Extruded-tee branch outlets in copper tubing may be made where specified.
- O. Install medical vacuum piping from medical vacuum service connections specified in this Section, to equipment specified in Section 226219 "Vacuum Equipment for Laboratory and Healthcare Facilities," and to equipment specified in other Sections requiring medical vacuum service.
- P. Piping Restraint Installation: Install seismic restraints on vacuum piping. Seismic-restraint devices are specified in Section 220548 "Vibration and Seismic Controls for Plumbing Piping and Equipment."
- Q. Install medical vacuum service connections recessed in walls. Attach roughing-in assembly to substrate; attach finishing assembly to roughing-in assembly.
- R. Install medical vacuum bottle bracket adjacent to each wall-mounted medical vacuum service connection suction inlet.
- S. Connect vacuum piping to vacuum producers and to equipment requiring vacuum service.
- T. Install unions in copper vacuum tubing adjacent to each valve and at final connection to each machine, specialty, and piece of equipment.
- U. Install sleeves for piping penetrations of walls, ceilings, and floors. Comply with requirements for sleeves specified in Section 220517 "Sleeves and Sleeve Seals for Plumbing Piping."
- V. Install escutcheons for piping penetrations of walls, ceilings, and floors. Comply with requirements for escutcheons specified in Section 220518 "Escutcheons for Plumbing Piping."

3.3 VALVE INSTALLATION

- A. Install shutoff valve at each connection to and from vacuum equipment and specialties.
- B. Install check valves to maintain correct direction of vacuum flow to vacuum-producing equipment.
- C. Install valve boxes recessed in wall and anchored to substrate. Single boxes may be used for multiple valves that serve same area or function.
- D. Install zone valves and gages in valve boxes. Rotate valves to angle that prevents closure of cover when valve is in closed position.
- E. Install flexible pipe connectors in suction inlet piping to each vacuum producer.

3.4 JOINT CONSTRUCTION

- A. Ream ends of pipes and tubes and remove burrs.
- B. Remove scale, slag, dirt, and debris from outside of cleaned tubing and fittings before assembly.
- C. Remove scale, slag, dirt, and debris from inside and outside of pipe and fittings before assembly.
- D. Threaded Joints: Apply appropriate tape to external pipe threads.
- E. Brazed Joints: Join copper tube and fittings according to CDA's "Copper Tube Handbook," "Brazed Joints" chapter. Do not use flux. Continuously purge joint with oil-free dry nitrogen during brazing.
- F. Flanged Joints:
 - 1. Copper Tubing: Install flange on copper tubes. Use pipe-flange gasket between flanges. Join flanges with gasket and bolts according to ASME B31.9 for bolting procedure.
 - 2. PVC Piping: Install PVC flange on PVC pipes. Use pipe-flange gasket between flanges. Join flanges with gasket and bolts according to ASME B31.9 for bolting procedure.
- G. Shape-Memory-Metal Coupling Joints: Join new copper tube to existing tube according to procedures developed by fitting manufacturer for installation of shape-memory-metal coupling joints.

3.5 HANGER AND SUPPORT INSTALLATION

- A. Comply with requirements in Section 220548 "Vibration and Seismic Controls for Plumbing Piping and Equipment" for seismic-restraint devices.
- B. Comply with requirements in Section 220529 "Hangers and Supports for Plumbing Piping and Equipment" for pipe hanger and support devices.
- C. Vertical Piping: MSS Type 8 or Type 42, clamps.
- D. Individual, Straight, Horizontal Piping Runs:
 - 1. 100 Feet and Less: MSS Type 1, adjustable, steel, clevis hangers.
 - 2. Longer Than 100 Feet: MSS Type 43, adjustable, roller hangers.
- E. Multiple, Straight, Horizontal Piping Runs 100 Feet or Longer: MSS Type 44, pipe rolls. Support pipe rolls on trapeze. Comply with requirements in Section 220529 "Hangers and Supports for Plumbing Piping and Equipment" for trapeze hangers.
- F. Base of Vertical Piping: MSS Type 52, spring hangers.
- G. Support horizontal piping within 12 inches of each fitting and coupling.
- H. Rod diameter may be reduced one size for double-rod hangers, with 3/8-inch- minimum rods.
- I. Install hangers for copper tubing with the following maximum horizontal spacing and minimum rod diameters:

1. NPS 1/4: 60 inches with 3/8-inch rod.
2. NPS 3/8 and NPS 1/2: 72 inches with 3/8-inch rod.
3. NPS 3/4: 84 inches with 3/8-inch rod.
4. NPS 1: 96 inches with 3/8-inch rod.
5. NPS 1-1/4: 108 inches with 3/8-inch rod.
6. NPS 1-1/2: 10 feet with 3/8-inch rod.
7. NPS 2: 11 feet with 3/8-inch rod.
8. NPS 2-1/2: 13 feet with 1/2-inch rod.
9. NPS 3: 14 feet with 1/2-inch rod.
10. NPS 3-1/2: 15 feet with 1/2-inch rod.
11. NPS 4: 16 feet with 1/2-inch rod.
12. NPS 6: 20 feet with 5/8-inch rod.

J. Install supports for vertical copper tubing every 10 feet.

3.6 IDENTIFICATION

- A. Install identifying labels and devices for laboratory vacuum piping, valves, and specialties. Comply with requirements in Section 220553 "Identification for Plumbing Piping and Equipment."
- B. Install identifying labels and devices for medical vacuum piping systems according to NFPA 99. Use the following or similar captions and color-coding for piping products where required by NFPA 99:
 1. Medical Vacuum: Black letters on white background.
 2. WAGD: White letters on violet background.

3.7 FIELD QUALITY CONTROL FOR HEALTHCARE FACILITY MEDICAL VACUUM PIPING

- A. Testing Agency: Engage a qualified testing agency to perform tests and inspections of medical vacuum piping systems in healthcare facilities and to prepare test and inspection reports.
- B. Tests and Inspections:
 1. Medical Vacuum Testing Coordination: Perform tests, inspections, verifications, and certification of medical vacuum piping systems concurrently with tests, inspections, and certification of medical compressed-air piping and medical gas piping systems.
 2. Preparation: Perform the following Installer tests according to requirements in NFPA 99 and ASSE Standard #6010:
 - a. Initial blowdown.
 - b. Initial pressure test.
 - c. Cross-connection test.
 - d. Piping purge test.
 - e. Standing pressure test for vacuum systems.
 - f. Repair leaks and retest until no leaks exist.
 3. System Verification: Perform the following tests and inspections according to NFPA 99, ASSE Standard #6020, and ASSE Standard #6030:
 - a. Standing pressure test.
 - b. Individual-pressurization or pressure-differential cross-connection test.

- c. Valve test.
 - d. Master and area alarm tests.
 - e. Piping purge test.
 - f. Final tie-in test.
 - g. Operational vacuum test.
 - h. Verify correct labeling of equipment and components.
4. Testing Certification: Certify that specified tests, inspections, and procedures have been performed and certify report results. Include the following:
- a. Inspections performed.
 - b. Procedures, materials, and gases used.
 - c. Test methods used.
 - d. Results of tests.
- C. Remove and replace components that do not pass tests and inspections and retest as specified above.

3.8 FIELD QUALITY CONTROL FOR LABORATORY FACILITY NONMEDICAL VACUUM PIPING

- A. Testing Agency: Engage qualified testing agency to perform field tests and inspections of vacuum piping in nonmedical laboratory facilities and to prepare test and inspection reports.
- B. Tests and Inspections:
- 1. Piping Leak Tests for Vacuum Piping: Test new and modified parts of existing piping. Cap and fill vacuum piping with oil-free, dry nitrogen. Isolate test source and let stand for four hours to equalize temperature. Refill system, if required, to test pressure; hold for two hours with no drop in pressure.
 - a. Test Pressure for Copper Tubing: 100 psig.
 - 2. Repair leaks and retest until no leaks exist.
 - 3. Inspect filters for proper operation.
- C. Remove and replace components that do not pass tests and inspections and retest as specified above.

3.9 PROTECTION

- A. Protect tubing from damage.
- B. Retain sealing plugs in tubing, fittings, and specialties until installation.
- C. Clean tubing not properly sealed, and where sealing is damaged, according to "Preparation" Article.

3.10 PIPING SCHEDULE

- A. Connect new copper tubing to existing copper tubing with memory-metal couplings.
- B. Flanges may be used where connection to flanged equipment is required.

- C. Medical Vacuum Piping: Use copper medical gas tube, wrought-copper fittings, and brazed joints.
- D. WAGD Piping: Use copper medical gas tube, wrought-copper fittings, and brazed joints.

3.11 VALVE SCHEDULE

- A. Shutoff Valves:
 - 1. Copper Tubing: Copper-alloy ball valve with manufacturer-installed ASTM B 819, copper-tube extensions.
- B. Zone Valves: Copper-alloy ball valve with manufacturer-installed ASTM B 819, copper-tube extensions with pressure gage on one copper-tube extension.

END OF SECTION 22 6213

SECTION 22 6314

MEDICAL GAS PIPING

PART 1 - GENERAL

1.1 RELATED DOCUMENTS

- A. Drawings and general provisions of the Contract, including General and Supplementary Conditions and Division 1 Specification Sections, apply to this Section.

1.2 SUMMARY

- A. This Section includes piping and related specialties for the following medical gas systems:

1. Oxygen piping, designated "oxygen," OX,
- 2.. Medical compressed-air piping, designated "medical air, MA.
3. Medical-surgical vacuum piping, designated "medical vacuum," V or MV.
4. Nitrous-oxide piping, designated "nitrous oxide," NO or N2O.
5. Nitrogen piping, designated "nitrogen," N or N2
6. Waste anesthetic gas disposal piping, designated "evacuation," EV or EVAC.

- B. Contractor furnished products and services.

1. All materials – Medical gas equipment and specialties including, but not limited to, valves, valve boxes, pressure controllers, pressure sensors, alarm panels, wall outlets, piping, fittings, hangers, labeling, etc. that are not owner-furnished required by contract documents NFPA 99, for a complete system.
2. The entire medical gas system shall, upon successful completion of Installer Performed Tests, be verified by an independent verifier

Verifier shall perform all tests required by NFPA 99 and all federal, state and local requirements, and submit results to the mechanical contractor for distribution to the general contractor, mechanical/plumbing engineer/s, owner, and others as directed by the project engineer.

- C. Owner-Furnished Products & Services: For Installation Under this Section:

1. The following products will be furnished by the owner under a Hospital Equipment contract:
 - a. Medical gas equipment such as ceiling booms, ceiling columns, etc.

- D. Owner will furnish medical gases for Phase II testing specified in this Section.

1.3 SUBMITTALS

- A. Product Data: For the following:

1. Medical gas tubes & fittings
2. Medical gas valves & valve boxes.

3. Medical gas specialties.
 4. Medical gas service connection & pressure control panels
 5. Medical gas service units. Include integral service connections.
 6. Medical gas alarm system components.
-
- B. Wiring diagrams for medical gas alarm systems and tanks. Differentiate between manufacturer-installed and field-installed wiring.
 - C. Coordination Drawings: For medical gas systems, including relationship to other services that serve same work areas.
 - D. Brazing Certificates: As required by ASME Boiler and Pressure Vessel Code, Section 1X, or AWS B2.2
 - E. Product Certificates: Signed by manufacturer certifying that copper tubing complies with NFPA 99, Paragraph 4-3.1.2.7, "Piping Materials."
 - F. Certificates of Shop Inspection and Data Report: As required by ASME Boiler and Pressure Vessel Code.
 - G. Inspection and test reports specified in "Field Quality Control" Article in Part 3 of this Section.
 - H. Certificates of inspections and tests from an independent testing agency specified in "Field Quality Control" Article in Part 3 of this Section.
 - I. Operation & Maintenance Data: For specialties to include in the maintenance manuals specified in Division 1.

1.4 QUALITY ASSURANCE

- A. Testing Agency Services: This Division will provide an independent testing agency to inspect, test, and certify medical gas piping and components, except for inspections and tests specified in "Field Quality Control" Article in Part 3 of this Section.
- B. Testing Agency Qualifications: Demonstrate to Architect's satisfaction, based on Architect's evaluation of criteria conforming to ASTM E 699 that the independent testing agency has the experience and capability to satisfactorily conduct the testing indicated without delaying the Work.
- C. Listing and Labeling: Provide electrically operated specialties specified in this Section that are listed and labeled.
 1. Terms "Listed" and "Labeled": As defined in National Electrical Code, Article 100.
 2. Listing and Labeling Agency Qualifications: A "Nationally Recognized Testing Laboratory" as defined in OSHA Regulation 1910.7.
- D. Comply with NFPA 70, "National Electrical Code."
- E. Comply with NFPA 99, "Health Care Facilities."
- F. Comply with UL 544, "Medical and Dental Equipment."

1.5 DELIVERY, STORAGE, AND HANDLING

- A. Deliver and store large medical gas specialties on factory-installed shipping skids, small specialties in factory-fabricated fiberboard containers, and piping with sealing plugs in ends or with other end protection.
 - 1. Store pre-cleaned and sealed medical gas pipe, fittings, valves, and specialties with sealing plugs and sealing packaging intact.
 - 2. Label medical gas pipe, fittings, valves, and specialties that have not been pre-cleaned, or that have been pre-cleaned but have seal or packaging that is not intact, with temporary labels indicating that cleaning is required before installation.

PART 2 - PRODUCTS

2.1 MANUFACTURERS

- A. Manufacturers: Subject to compliance with requirements, provide products by one of the following:
 - 1. Medical Gas Piping Specialties:
 - a. Chemtron
 - 2. Medical Gas Alarm Systems:
 - a. Chemtron

2.2 PIPE AND TUBES

- A. Pre-cleaned, Hard Copper Tube: ASTM B 819, Type K or Type L, seamless, drawn temper, factory cleaned, purged, and sealed for medical gas service. Include marking or labeling "CLEANED FOR MEDICAL GAS SERVICE," "CLEAN FOR OXYGEN SERVICE," "NITROGENIZED."
- B. Soft Copper Tube: ASTM B 88, Type K water tube, seamless, annealed temper. Tube may be factory cleaned, purged, and sealed for medical gas service according to ASTM B 819 or field cleaned, purged, and sealed as specified in "Preparation" Article in Part 3. Include marking or labeling "CLEANED FOR MEDICAL GAS SERVICE," "CLEAN FOR OXYGEN SERVICE," "NITROGENIZED."

2.3 PIPE AND TUBE FITTINGS

- A. Wrought-Copper Fittings: ASME B16.22, solder-joint, pressure type. Fittings may be factory cleaned, purged, and sealed for medical gas service according to ASTM B 819 or field cleaned, purged, and sealed as specified in "Preparation" Article in Part 3. Include marking or labeling "CLEANED FOR MEDICAL GAS SERVICE," "CLEAN FOR OXYGEN SERVICE," "NITROGENIZED."
- B. Bronze-Tube Flanges: ASME B16.24, Class 300.
- C. Flexible Connectors: Bronze or stainless-steel flexible pipe connectors as specified in Division 22 Section "Vibration Control."

2.4 JOINING MATERIALS

- A. Refer to Division 23 Section "Basic Mechanical Materials and Methods" for joining materials not in this Section.
- B. Brazing Filler Metals: AWS A5.8, BCuP (copper-phosphorus) series alloys. Flux is prohibited, except when used with bronze fittings.
- C. Threaded-Joint Tape: PTFE plastic.
- D. Gasket Material: ASME B16.21, nonmetallic, flat, asbestos free, and suitable for oxygen use.

2.5 VALVES AND VALVE BOXES

- A. Ball Valves, 3-Inch NPS and Smaller: MSS SP-110, bronze-body, full-port valve rated for 300-psig working pressure, with chrome-plated brass ball, PTFE or TFE seals, blowout-proof stem, threaded or braze-joint ends. Provide locking type for valves not located in valve box and handle designed for quarter turn between open and closed positions.
 - 1. Include union-type body with bolted swing-away center section.
 - 2. Include factory-cleaned, factory-sealed for oxygen use, and factory-installed, ASTM B 88, Type K or L, copper-tube extensions with pressure gage installed downstream from valve in pressure systems and upstream from valve in vacuum systems.
- B. Ball Valves, 4-Inch NPS and Larger: MSS SP-72, bronze- or iron-alloy body, full-port valve rated for 300-psig working pressure, with chrome-plated brass ball valve, PTFE or TFE seals, blowout-proof stem, flanged ends, and provide locking type for valves not located in a valve box, and handle designed for quarter turn between open and closed positions.
- C. Check Valves, 3-Inch NPS and Smaller: Bronze-body, straight-through pattern, spring-loaded ball check valve, designed for 300-psig minimum working pressure.
- D. Check Valves, 4-Inch NPS and Larger: MSS SP-71, Class 250, iron-body, bronze-trim, swing check valve, with flanged ends.
- E. Safety Valves: Bronze body with settings to match system requirements.
 - 1. Pressure Safety Valves: ASME construction.
 - 2. Vacuum Relief Valves: Equipment manufacturer's option.
- F. Pressure Regulators: Brass or bronze body and trim; spring-loaded, diaphragm-operated, relieving type; manual pressure-setting adjustment; rated for 250-psig minimum inlet pressure; and capable of controlling delivered air pressure within 0.5 psig for each 10-psig inlet pressure.
- G. Automatic Drain Valves: Corrosion-resistant metal body and internal parts, 200-psig minimum working-pressure rating, capable of automatic discharge of collected condensate.
- H. Zone Valve Boxes: Minimum 0.048-inch- thick steel, valve boxes for recessed mounting, with holes for medical gas piping and anchors. Include for single- or multiple-valve (with pressure gage) installation and in sizes to permit manual operation of valves.

1. Interior Finish: Factory-applied white enamel.
2. Cover Plate: Minimum 0.08-inch- thick aluminum or extruded-anodized aluminum with frangible or removable windows.
3. Valve-Box Windows: Clear or tinted transparent plastic with labeling, including space for rooms served, according to NFPA 99.

2.6 MEDICAL GAS PIPING SPECIALTIES

- A. General: Provide the following medical gas piping specialties by same manufacturer:
- B. Service Outlets (wall type): Gas specific for services listed with roughing-in and finishing assemblies. Include the following:
1. Roughing-in Assembly: Include the following:
 - a. Steel outlet box or mounting plate.
 - b. Brass-body outlet block with secondary check valve that will prevent gas flow when primary valve is removed.
 - c. Double seals that will prevent gas leakage.
 - d. ASTM B 88, Type K, 3/8-inch NPS copper inlet or outlet tube brazed to valve with gas-service marking and tube-end dust cap.
 2. Finishing Assembly: Include the following:
 - a. Brass housing with primary check valve.
 - b. Double seals that will prevent gas leakage.
 - c. Cover plate with gas-service label.
 3. Quick-Connect Coupling: Indexing to prevent interchange between services, constructed to permit one-handed connection and removal of equipment, and with positive-locking that retains equipment stem in valve during use. Outlets to be Chemetron faceplate style. All new outlets to be Allied. Contractor to provide pricing for alternate manufactures. See mechanical bid form.
 4. DISS-Type Coupling: CGA V-5, DISS-threaded indexing to prevent interchange between services; constructed to permit one-handed connection and removal of equipment.
 - a. Oxygen Outlets: CGA V-5, DISS No. 1240.
 - b. Medical Air Outlets: CGA V-5, DISS No. 1160.
 - c. Medical Vacuum Inlets: CGA V-5, DISS No. 1220.
 - d. Nitrous-Oxide Outlets: CGA V-5, DISS No. 1040.
 - e. Nitrogen Outlets: CGA V-5, DISS No. 1120.
 - f. Evacuation Inlets: CGA V-5, DISS No. 2220.
 - g. Carbon-Dioxide Outlets: CGA V-5, DISS No. 1080.
 - h. High-Pressure Air Outlets: CGA V-5, DISS No. 1160.
 5. Wall Outlet Cover Plates: One-piece metal, with chrome-plated finish and permanent, color-coded, medical gas identifying label matching corresponding outlets.
 6. Vacuum Bottle-Slide Brackets: Bottle-slide and mounting assembly matching pattern of vacuum outlet. Include one slide bracket for each wall-mounted vacuum inlet, except where no slide bracket requirement is indicated or for ceiling outlets.
- C. Outlet Cover Plates: One-piece stainless steel, with NAAMM AMP 503, No. 4 finish and permanent identifying label.

- D. Outlet Cover Plates: One-piece metal, with chrome-plated finish and permanent identifying label.
- E. Outlet Cover Plates: One-piece anodized aluminum, with permanent identifying label.

2.7 MEDICAL GAS ALARM SYSTEMS

- A. Description: Compatible alarm panels, remote sensing devices, and other related components where indicated and where required by NFPA 99. Power wiring is specified in Division 16 Sections. Panel wiring is by Division 15, Automatic Temperature Controls.
- B. Components: Designed for continuous service and to operate on power supplied from 120-V, ac power source to alarm panels and with connections for 24- or 12-V, ac low-voltage wiring to remote sensing devices. Include step-down transformers if required.
- C. Pressure and Vacuum Switches or Pressure Transducer Sensors: Continuous line monitoring with electrical connections for alarm system.
 - 1. Low-Pressure Switches: 0- to 100-psig operating range.
 - 2. High-Pressure Switches: Up to 250-psig operating range.
 - 3. Vacuum Switches: 0- to 30-in. Hg range.
- D. Alarm Panels: Factory wired with audible and color-coded visible signals to indicate specified functions.
 - 1. Mounting: Recessed installation.
 - 2. Enclosures: Fabricated from minimum 0.047-inch- thick steel or minimum 0.05-inch-thick aluminum, and with knockouts for electrical and piping connections.
 - 3. Area Alarm Panels: Separate trouble alarm signals; pressure and vacuum gages; and indicators for gases served - oxygen, medical air, and medical vacuum.
 - 4. Signal alarms at area alarm panels and at anesthetizing-area alarm panels when the following conditions exist:
 - a. Oxygen: Pressure drops below 40 psig or rises above 60 psig.
 - b. Medical Air: Pressure drops below 40 psig or rises above 60 psig.
 - c. Medical Vacuum: Vacuum drops below 12 in. Hg
 - d. Nitrous Oxide: Pressure drops below 40 psig or rises above 60 psig.
 - e. Nitrogen: Pressure drops below 160 psig or rises above 200 psig.
 - f. Evacuation: Vacuum drops below 12 in. Hg.

2.8 IDENTIFICATION

- A. Refer to Division 23 Section "Mechanical Identification" for piping, valves, gages, alarms, accessories, and labels for bulk storage tanks.

PART 3 - EXECUTION

3.1 PREPARATION

- A. General: Where factory-precleaned and -capped piping is not available, or when precleaned piping must be recleaned because of exposure, perform the following procedures:

1. Clean medical gas pipe and pipe fittings, valves, gages, and other components of oil, grease, and other readily oxidizable materials as required for oxygen service, according to CGA G-4.1, "Cleaning Equipment for Oxygen Service."
2. Wash medical gas piping and components in hot, alkaline cleaner-water solution of sodium carbonate or trisodium phosphate in proportion of 1 lb of chemical to 3 gal. of water.
 - a. Scrub to ensure complete cleaning.
 - b. Rinse with clean, hot water after washing to remove cleaning solution.

3.2 PIPING APPLICATIONS

A. General: Refer to Part 2 of this Section for the following materials:

1. Interior and Medical Gas Piping: Use precleaned, hard copper tube with wrought-copper fittings and brazed joints.
2. Exterior, Buried Medical Gas Piping: Use soft copper tube with wrought-copper fittings and brazed joints.
3. Underground, Protective Conduit: Use Schedule 80 PVC plastic pipe, Schedule 80 PVC plastic threaded pipe fittings, and threaded joints; or Schedule 80 PVC plastic socket-type pipe fittings, and solvent cement joints.

3.3 SERVICE ENTRANCES

- A. Extend piping and connect to bulk storage tanks and exterior manifolds, of sizes and in locations indicated for service entrances to building.
- B. Install sleeve and mechanical sleeve seal at penetrations through foundation wall for watertight installation.

3.4 PIPING INSTALLATION, GENERAL

- A. Refer to Division 23 Section "Basic Mechanical Materials and Methods" for basic piping installation.
- B. Install supports and anchors according to Division 23 Section "Hangers and Supports."
 1. Spacing between Hangers: As described in NFPA 99 and NFPA 99C..
- C. Valve Applications: Use ball valves specified in this Section for main shutoff and zone valve duties.
- D. Comply with SEI/ASCE 7 and with requirements for seismic-restraint devices in Section 220548 "Vibration and Seismic Controls for Plumbing Piping and Equipment."
- E. Install zone valves in valve box anchored to structure. Install valves at angle that prevents closure of cover when valve is in closed position. Single boxes may be used for multiple valves that serve same area or function.
- F. Install thermometers and pressure gages according to Division 15 Section "Meters and Gages."

- G. Install exterior, buried medical gas piping in protective conduit fabricated with PVC pipe and fittings. Do not extend conduit through foundation wall. Provide sand bedding 6" all around and metallic warning tape 18" above pipe. Bury pipe at 36" depth.
- H. Purging: Purge medical gas piping using oil-free, dry nitrogen during brazing and after installing piping but before connecting to service-outlet valves, alarms, and gages.

3.5 JOINT CONSTRUCTION

- A. Refer to Division 23 Section "Basic Mechanical Materials and Methods" for basic piping joint construction.

3.6 SPECIALTIES INSTALLATION

- A. Install specialties according to NFPA 99 and manufacturer's written instructions.
- B. Install manifolds firmly anchored to substrate and with seismic controls as indicated.
- C. Connect to ceiling-mounting service units firmly anchored to substrate according to manufacturer's written instructions.

3.7 MEDICAL GAS ALARM SYSTEM INSTALLATION

- A. General: Install alarm system components according to NFPA 99 and manufacturer's written instructions.
- B. Install alarm panels in locations indicated.

3.8 CONNECTIONS

- A. Install piping next to equipment to allow service and maintenance.
- B. Connect medical gas piping to equipment, gas manifolds, and accessories with unions. Install with ball valves and strainers.
- C. Install medical gas piping and electrical connections to medical gas alarm system components.
- D. Arrange for electric-power connections to specialties and devices that require power. Electric power, wiring, and disconnect switches are specified in Division 26 Sections.

3.9 LABELING AND IDENTIFICATION

- A. Install labeling on valves, valve-box covers, and alarm panels according to requirements of NFPA 99.
- B. Refer to Division 23 Section "Mechanical Identification" for labeling and identification materials.
- C. Captions and Color Coding: Use the following or similar medical gas captions and color coding for specialties, when specified and where required by NFPA 99:

1. Oxygen: White letters on green background.
 2. Medical Air: Black or white letters on yellow background.
 3. Medical Vacuum: Black letters on white background.
 4. Nitrous Oxide: White letters on blue background.
 5. Nitrogen: White letters on black background.
- D. Label medical gas systems operating at other than standard pressure with system operating pressure.
- E. Install continuous metallic underground warning tape during backfilling of trench for underground medical gas piping.

3.10 FIELD QUALITY CONTROL

- A. Pressure Test: Subject each piping section of each system, except high-pressure air and nitrogen, to test pressure of from 150 to 200 psig and high-pressure air and nitrogen systems to test pressure of 250 psig with oil-free, dry nitrogen before attaching system components, after installing station outlets with test caps (when supplied) in place, and before concealing piping system. Maintain test until joints are examined for leaks by means of soapy water.
- B. Standing-Pressure Test: Install assembled system components after testing individual systems as specified above. Subject systems to 24-hour standing-pressure test at 20 percent above normal line pressure, but not less than 66 psig. Subject vacuum and evacuation systems to 12- to 18-in. Hg minimum vacuum instead of pressure test.
- C. Repair leaks, replace damaged components with new materials, and retest system until satisfactory results are obtained.
- D. Inspect, test, and certify complete medical gas systems according to requirements of NFPA 99, "Health Care Facilities." Inspect, test, and certify each medical gas system, including each piping system, outlets and inlets, accessories, alarm panels and devices, safety devices, medical gas sources, and equipment.
- E. Provide oil-free, dry nitrogen; materials; equipment; and labor required for testing.
- F. Provide medical gases required for testing systems.
- G. Prepare written reports of tests results, including corrective action.
- H. Certify that medical gas systems comply with requirements specified, that tests were properly performed, and that test results were satisfactory.
- I. Inspect outlets and inlets, gages, alarms, and zone valves for proper labeling for gas service and function.
- J. Inspect manifold supply systems for installation and operation as required by NFPA 99, Chapter 4, "Gas and Vacuum Systems."
- K. Phase I Tests: Perform the following tests using oil-free, dry nitrogen after installing gas systems but before connecting new systems to existing gas sources:

1. Outlet and Inlet Cross-Connection Test: Pressurize one medical gas system to 50 psig, with other systems at atmospheric pressure, and access each outlet with appropriate adapter and test gage. Repeat procedure for each system.
 2. Outlet and Inlet Cross-Connection Test: Pressurize each system in 10-psig increments and access each outlet with appropriate adapter and test gage.
 3. Alarm System Test: Test for operation of functions specified in "Medical Gas Alarm Systems" Article within limits required.
 4. Pressure Test: Test systems at operational pressure with system components installed. No leaks are allowed. Conduct tests by zone.
 5. Particulate Sampling: Test positive-pressure terminal outlets, using 0.45-micron filter, for evidence of solid particulate contamination. Allowable limit is 2 mg/cu. m.
 6. Moisture: Test positive-pressure terminal outlets for dew point to verify absence of moisture in piping. Dew point of gas dispensed from terminal outlets shall not exceed dew point of source test gas by more than 4 deg F.
 7. System Purity: Test terminal outlets and gas source for contaminant levels as defined below. Excessive contaminant levels will require additional purging to outlets within specific zone until levels are within the following limits:
 - a. Total Hydrocarbons as Methane: One ppm.
 - b. Halogenated Hydrocarbons: 2 ppm.
 - c. Carbon Monoxide: 2 ppm.
- L. Phase II Tests: After Phase I testing has been completed, test completed medical gas systems using applicable medical gas for each system. Completed systems have outlets and inlets, alarms, and gages installed; and gas supply systems are installed and ready for operation.
1. Final Purging: Introduce applicable medical gas for each system into respective piping systems. Purge installed outlet valves to remove nitrogen test gas present from Phase I testing. Test vacuum inlets for ability to flow.
 2. Outflow Analysis: Analyze medical gas at positive-pressure outlets to confirm delivery of proper medical gas at proper concentration level. Minimum allowable concentration levels are defined by U.S. Pharmacopeia's USP-NF and the following CGA Commodity Specifications:
 - a. CGA G-4.3, "Commodity Specification for Oxygen."
 - b. CGA G-6.2, "Commodity Specification for Carbon Dioxide."
 - c. CGA G-7.1, "Commodity Specification for Air."
 - d. CGA G-8.2, "Commodity Specification for Nitrous Oxide."
 - e. CGA G-10.1, "Commodity Specification for Nitrogen."
 3. System Delivery Pressures: Test pressure piping systems to confirm supply sources are set to deliver gas at the following nominal pressure levels:
 - a. All Systems, except Nitrogen and High-Pressure Air: 50 to 55 psig at maximum flow.
 - b. Nitrogen and High-Pressure Air: 180 psig minimum at maximum flow.
 4. System Suction Levels: Test vacuum and evacuation piping systems to confirm that vacuum producers are set to maintain suction of not less than 12 in. Hg at most distant inlets.
- M. Testing Agency Certification: Certify that specified inspection, tests, and procedures have been performed and report results. Include the following:
1. Inspections performed.
 2. Procedures, materials, and gases used.

3. Test methods used.
4. Results of tests.

3.11 COMMISSIONING

- A. Startup Services: Engage a factory-authorized service representative to inspect alarm system installation and to provide startup service.
 1. Test and adjust controls and safeties. Replace damaged and malfunctioning controls and equipment discovered by service representative.
- B. Perform the following final checks before startup:
 1. Verify that specified tests of piping are complete.
 2. Check safety valves for correct settings. Ensure settings are greater than air-compressor discharge pressure, but not greater than rating of system components.

3.12 DEMONSTRATION

- A. Startup Services: Engage a factory-authorized service representative to demonstrate procedures for alarm system startup and shutdown, preventive maintenance and servicing, and troubleshooting. Review operating and maintenance information.
- B. Provide written notice 7 days in advance of demonstration.

END OF SECTION 22 6314

THIS PAGE LEFT BLANK INTENTIONALLY

DIVISION 23 – HEATING, VENTILATING, AND AIR CONDITIONING

Section 23 0100	Mechanical Requirements
Section 23 0150	Temporary Use of Equipment and Systems
Section 23 0500	Common Work Result for HVAC
Section 23 0513	Common Motor Requirements for HVAC Equipment
Section 23 0517	Sleeves and Sleeve Seals for HVAC Piping
Section 23 0518	Escutcheons for HVAC Piping
Section 23 0519	Meters and Gages for HVAC
Section 23 0523	General-Duty Valves for HVAC Piping
Section 23 0529	Hangers and Supports for HVAC Piping and Equipment
Section 23 0548	Vibration and Seismic Controls for HVAC
Section 23 0550	Operation and Maintenance of HVAC Systems
Section 23 0553	Identification for HVAC Piping and Equipment
Section 23 0593	Testing, Adjusting, and Balancing for HVAC
Section 23 0713	Duct Insulation
Section 23 0719	HVAC Piping Insulation
Section 23 0900	Instrumentation and Control for HVAC
Section 23 2113	Hydronic Piping
Section 23 2116	Hydronic Piping Specialties
Section 23 3001	Common Duct Requirements
Section 23 3113	Metal Ducts
Section 23 3300	Air Duct Accessories
Section 23 3423	HVAC Power Ventilators
Section 23 3600	Air Terminal Units
Section 23 3713	Diffusers, Registers, and Grilles

THIS PAGE LEFT BLANK INTENTIONALLY

SECTION 23 0100

MECHANICAL REQUIREMENTS

PART 1 - GENERAL

1.1 GENERAL CONDITIONS

- A. The General Conditions of the Contract, with the amendments, supplements, forms and requirements in Division 01, and herewith made a part of this Division.
- B. All sections of Division 21, 22, & 23 shall comply with the Mechanical General Requirements. The standards established in this section as to quality of materials and equipment, the type and quality of workmanship, mode of operations, safety rules, code requirements, etc., shall apply to all sections of this Division as though they were repeated in each Division.
- C. Mechanical equipment that is pre-purchased if any will be assigned to the Mechanical Contractor. By assignment to the Mechanical Contractor, the Mechanical Contractor shall accept and installed the equipment and provide all warranties and guarantees as if the Mechanical Contractor had purchased the equipment.
- D. Construction Indoor-Air Quality Management
 - 1. Comply with SMACNA's "SMACNA IAQ Guideline for Occupied Buildings under Construction."
 - a. If Owner authorizes use of permanent heating, cooling, and ventilating systems during construction period as specified in Division 01 Section "Temporary Facilities and Controls," install filter media having a MERV 8 according to ASHRAE 52.2 at each return-air inlet for the air-handling system used during construction.
 - b. Replace all air filters immediately prior to occupancy.
 - 2. Comply with one of the following requirements:
 - a. After Construction ends, prior to occupancy and with all interior finishes installed, perform a building flush-out by supplying a total volume of 14000 cu. Ft. of outdoor air per sq. ft. of floor area while maintaining an internal temperature of at least 60 deg F and a relative humidity no higher than 60 percent.
 - b. If occupancy is desired prior to flush-out completion, the space may be occupied following delivery of a minimum of 3500 cu. ft. of outdoor air per sq. ft. of floor area to the space. Once a space is occupied, it shall be ventilated at a minimum rate of 0.30 cfm per sq. ft. of outside air or the design minimum outside air rate determined in EQ Prerequisite 1, whichever is greater. During each day of the flush-out period, ventilation shall begin a minimum of three hours prior to occupancy and continue during occupancy. These conditions shall be maintained until a total of 14000 cu. ft./sq. ft. of outside air has been delivered to the space.
- E. LEED REQUIREMENT
 - 1. The Contractor is to submit all LEED information needed by the Design Professional to demonstrate that particular credits have been achieved. In particular, credits that depend on knowing the cost and quantity of certain types of products cannot be achieved without obtaining that information from the Contractor. These include renewable content, locally sourced new products, and reused products. In addition, a form is provided for each installer to certify that they have not used adhesives, sealants, and for suppliers and installers to certify they have not used composite wood with prohibited VOC content.

1.2 SCOPE OF WORK

- A. The project described herein is the Primary Children's iMRI project. This work shall include all labor, materials, equipment, fixtures, and devices for the entire mechanical work and a complete operating and tested installation as required for this project.

1.3 CODES & ORDINANCES

- A. All work shall be executed in accordance with all underwriters, public utilities, local and state rules and regulations applicable to the trade affected. Should any change in the plans and Specifications be required to comply with these regulations, the Contractor shall notify the Architect before the time of submitting his bid. After entering into contract, the Contractor will be held to complete all work necessary to meet these requirements without extra expense to the Owner. Where work required by drawings or specifications is above the standard required, it shall be done as shown or specified.
- B. Applicable codes:
 - 1. Utah Boiler and Pressure Vessel Rules and Regulations- Latest Edition
 - 2. International Building Code- 2018 Edition
 - 3. International Mechanical Code- 2018 Edition
 - 4. International Plumbing Code- 2018 Edition
 - 5. International Fire Code- 2018 Edition
 - 6. ASHRAE Standard 90.1 - 2016 Edition
 - 7. International Fuel Gas Code- 2018 Edition
 - 8. National Electrical Code- 2016 Edition
 - 9. ASHRAE Standard 62.1 – 2016 Edition
 - 10. ASHRAE Standard 170 – 2017 Edition

1.4 INDUSTRY STANDARDS

- A. All work shall comply with the following standards.
 - 1. Associated Air Balance council (AABC)
 - 2. Air Conditioning and Refrigeration Institute (ARI)
 - 3. Air Diffusion council (ADC)
 - 4. Air Movement and Control Association (AMCA)
 - 5. American Gas Association (AGA)
 - 6. American National Standards Institute (ANSI)
 - 7. American Society of Heating, Refrigeration, and Air Conditioning Engineers (ASHRAE)
 - 8. American Society of Mechanical Engineers (ASME)
 - 9. American Society of Testing Materials (ASTM)
 - 10. American Water Works Association (AWWA)
 - 11. Cooling Tower Institute (CTI)
 - 12. ETL Testing Laboratories (ETL)
 - 13. Institute of Electrical and Electronic Engineers (IEEE)
 - 14. Hydraulics Institute (HI)
 - 15. Manufacturers Standardization Society of the Valve and Fitting Industry (MSS)
 - 16. National Fire Protection Association (NFPA)
 - 17. National Electrical Code (NEC)
 - 18. National Electrical Manufacturers Association (NEMA)
 - 19. National Electrical Safety code (NESC)
 - 20. Utah safety Standard (OSHA), Utah State Industrial Council.
 - 21. Sheet Metal and Air Conditioning Contractor's National Association (SMACNA)
 - 22. Underwriters Laboratories (UL)
 - 23. Tubular Exchanger Manufacturers Association, Inc. (TEMA)
 - 24. Heat Exchanger Institute (HEI)
 - 25. Hydraulic Institute (HI)
 - 26. Thermal Insulation Manufacturer's Association (TIMA)
 - 27. Scientific Apparatus Makers Association (SAMA)

- B. Compliance Verification:
1. All items required by code or specified to conform to the ASME code shall be stamped with the ASME seal.
 2. Form U-1, the manufacturer's data report for pressure vessels, is to be included in the Operation and Maintenance Manuals. National Board Register (NBR) numbers shall be provided where required by code.
 3. Manufactured equipment which is represented by a UL classification and/or listing, shall bear the UL or equivalent ETL label.

1.5 UTILITIES & FEES

- A. All fees for permits required by this work will be paid by this division with the understanding that any fees that are required to be paid will be reimbursed by the owner. The contractor shall obtain the necessary permits to perform this work. Unless noted otherwise, all systems furnished and or installed by this Contractor, shall be complete with all utilities, components, commodities and accessories required for a fully functioning system. This Contractor shall furnish smoke generators when required for testing, furnish glycol for glycol piping systems, full load of salt to fill brine tank for water softening system, furnish cleaners and water treatment additives.

1.6 SUBMITTALS AND SHOP DRAWINGS

- A. General: As soon as possible after the contract is awarded, but in no case more than 45 calendar days thereafter, the Contractor shall submit to the Architect manufacturer's data on products and materials to be used in the installation of mechanical systems for this project. The review of the submitted data will require a minimum of 14 days. The first day starts after the day they are received in the engineer's office to which the project is being constructed from. If the Contractors schedule requires return of submitted literature in less than the allotted time, the Contractor shall accelerate his submittal delivery date. The Contractor shall resubmit all items requiring re-review within 14 days of returned submittals. Refer to each specification section for items requiring submittal review. If the re-submittal is returned a 2nd time for correction the Contractor will provide the specific equipment that is specified on the drawings and/or the specifications. Written approval of the Owner's Representative shall be obtained before installing any such equipment or materials for the project.
- B. Review by the Owner's Representative is for general conformance of the submitted equipment to the project specification. In no way does such review relieve this Contractor of his obligation to furnish equipment and materials that comply in detail to the specification nor does it relieve the Contractor of his obligation to determine actual field dimensions and conditions that may affect his work. Regardless of any items overlooked by the submittal review, the requirements of the contract drawings and specifications must be followed and are not waived or superseded in any way by the review.
- C. By description, catalog number, and manufacturer's names, standards of quality have been established by the Architect and the Engineer for certain manufactured equipment items and specialties that are to be furnished by this Division. Alternate products and equipment may be proposed for use only if specifically named in the specifications or if given written prior approval in published addenda. Design equipment is the equipment listed on the drawings or if not listed on the drawings is the equipment first named in the specifications.
- D. Submittal Format: At the contractor's discretion, project submittals may be in either of the formats described in the following paragraphs, but mixing the two formats is not acceptable.
1. Electronic Submittal Format: Identify and incorporate information in each electronic submittal file as follows:
 - a. All items shall be submitted at one time except automatic temperature control drawings and seismic restraint drawings which may be submitted separately within

120 days of the contract award date. Partial submittals will not be reviewed until the complete submittal is received.

- b. Submitted electronic file shall bear the Contractor's stamp, indicating that he has checked all equipment being submitted; that each item will fit into the available space with the accesses shown on the drawings; and, further, that each item conforms to the capacity and quality standards given in the contract documents.
- c. Submitted electronic file shall clearly indicate performance, quality, and utility requirements; shall show dimension and size of connection points; and shall include derating factors that were applied for each item of equipment to provide capacity at job site elevation. Temperature control submittals shall include piping and wiring diagrams, sequence of operation and equipment. Equipment must fit into the available space with allowance for operation, maintenance, etc. Factory piped and wired equipment shall include shop drawings for all internal wiring and piping furnished with the unit.
- d. Submitted electronic file shall clearly show all required field install wiring, piping, and accessory installations required by the Contractor to provide a complete operating system.
- e. Assemble complete submittal package into a single indexed file incorporating submittal requirements of a single Specification Section and transmittal form with links enabling navigation to each item.
- f. Name file with submittal number or other unique identifier, including revision identifier.
- g. Electronic file shall be completely electronically searchable or it will be rejected.
- h. Provide means for insertion to permanently record Contractor's review and approval markings and action taken by:
 - 1) Architect.
- i. Transmittal Form for Electronic Submittals:
 - 1) Use one of the following options acceptable to the Owner;
 - a) Software-generated form from electronic project management software.
 - b) Electronic form.
 - 2) The Electronic Submittal shall contain the following information:
 - a) Project name.
 - b) Date.
 - c) Name and address of Architect.
 - d) Name of Construction Manager.
 - e) Name of Contractor.
 - f) Name of firm or entity that prepared submittal.
 - g) Names of subcontractor, manufacturer, and supplier.
 - h) Category and type of submittal.
 - i) Submittal purpose and description.
 - j) Specification Section number and title.
 - k) Specification paragraph number or drawing designation and generic name for each of multiple items.
 - l) Drawing number and detail references, as appropriate.
 - m) Location(s) where product is to be installed, as appropriate.
 - n) Related physical samples submitted directly.
 - o) Indication of full or partial submittal.
 - p) Transmittal number[, numbered consecutively].
 - q) Submittal and transmittal distribution record.
 - r) Other necessary identification.
 - s) Remarks.
- j. Metadata: Include the following information as keywords in the electronic submittal file metadata:
 - 1) Project name.
 - 2) Number and title of appropriate Specification Section.

- 3) Manufacturer name.
- 4) Product name.

- E. Submittal Requirements - Submittals MUST be compiled in PDF format, organized, properly labeled with specification sections, and book marked.
1. Mail physical samples to Archer Mechanical 2745 W. California Ave., Salt Lake City, UT 84104
 2. Submittal files larger than 25MB must be delivered to the Archer Mechanical office via thumb drive.
 3. Subcontractor/Vendor markups should be purple. GC markups will be blue, architect markups will be red, and consultant markups will be green. Any variations of sizing and/or performance shall be clearly indicated with an explanation of variation.
 4. Submittals must be submitted no later than two weeks from notice.
 5. Partial submittals will not be accepted. All required test data, certifications, qualification data, schedules, shop drawings, test reports, etc. must be included.
 6. Substitutions not previously accepted will not be allowed in submittals.
 7. All clarifications and questions about scope of work must be submitted in RFI(s) rather than in submittals
 8. Specific schedule of lead times for all items that are not 'off the shelf' must be submitted within 10 days of NTP. (See schedule requirements)

1.7 DRAWINGS AND MEASUREMENTS

- A. Construction Drawings: The contract document drawings show the general design, arrangements, and extent of the system. In certain cases, the drawings may include details that show more nearly exact locations and arrangements; however, the locations, as shown diagrammatically, are to be regarded as general.
- B. It shall be the work of this Section to make such slight alterations as may be necessary to make adjustable parts fit to fixed parts, leaving all complete and in proper shape when done. All dimensions given on the drawings shall be verified as related to this work and with the Architect's office before work is started.
- C. This Section shall carefully study building sections, space, clearances, etc., and then provide offsets in piping or ductwork as required to accommodate the building structure without additional cost to the Owner. In any case and at any time during the construction process, a change in location required by obstacles or the installation of other trades not shown on the mechanical plans shall be made without charge.
- D. The drawings shall not be scaled for roughing in measurements nor shall they be used as shop drawings. Where drawings are required for these purposes or where drawings must be made from field measurements, the Contractor shall take the necessary measurements and prepare the drawings. Shop drawings of the various subcontractors shall be coordinated to eliminate all interferences and to provide sufficient space for the installation of all equipment, piping, ductwork, etc.
- E. The drawings and specifications have been prepared to supplement each other and they shall be interpreted as an integral unit with items shown on one and not the other being furnished and installed as though shown and called out on both.
- F. Coordination Drawings: The contractor shall provide coordination drawings for mechanical rooms, fan rooms, equipment rooms, and congested areas to eliminate conflicts with equipment, piping, or work of other trades. The drawings shall be a minimum scale of 1/4 inch= 1 foot and of such detail as may be required by the Engineer to fully illustrate the work. These drawings shall include all piping, conduit, valves, equipment, and ductwork.
- G. Sheet-metal shop drawings will be required for all ductwork in the entire building. These drawings will show all ductwork in the entire building and shall be coordinated with architectural, structural and electrical portions of the project. The contractor shall specifically obtain copies of

the structural shop drawings and shall coordinate the ductwork shop drawings with approved structural members. These drawings shall be submitted to the engineer for review prior to any fabrication. The contractor is responsible for all modifications necessary to accommodate duct installation within the structural, architectural and electrical restrictions. These drawings, once reviewed by the engineer, will be made available to all mechanical, electrical, and fire sprinkler subcontractors to coordinate installation of their work.

1.8 CONTRACTOR'S USE OF BUILDING EQUIPMENT

- A. The Contractor may use equipment such as electric motors, fans, heat exchangers, filters, etc., with the written permission of the Owner. As each piece of equipment is used (such as electric motors and fans), maintenance procedures approved by the manufacturer are to be followed. A careful record is to be kept of the length of the time the equipment is used, maintenance procedures followed, and any difficulty encountered. The record is to be submitted to the Owner upon acceptance. All fan belts and filter media (such as bearings) shall be carefully inspected just prior to acceptance. Any excessive wear noted shall require replacement. New filter media shall be installed in air handlers at the time systems are turned over to the owner.

1.9 EXISTING CONDITIONS

- A. The Contractor shall carefully examine all existing conditions that might affect the mechanical system and shall compare these conditions with all drawings and specifications for work included under this contract. He shall, at such time, ascertain and check all conditions that may affect his work. No allowance shall subsequently be made in his behalf for an extra expense incurred as a result of his failure or neglect to make such examination. This Contractor shall include in his bid proposal all necessary allowances to repair or replace any item that will remain or will be removed, and any item that will be damaged or destroyed by new construction.
- B. The Contractor shall remove all abandoned piping, etc., required by new construction and cap or plug openings. No capping, etc., shall be exposed in occupied areas. All openings of items removed shall be sealed to match adjacent surfaces.
- C. The Contractor shall verify the exact location of all existing services, utilities, piping, etc., and make connections to existing systems as required or as shown on the drawings. The exact location of each utility line, together with size and elevation, shall be established before any on-site lines are installed. Should elevation or size of existing main utility lines make connections to them impossible as shown on drawings, then notification of such shall immediately be given to the Owners Representative for a decision.
- D. Any HVAC system that is modified shall be rebalanced and recommissioned additional requirements. If the unit modified serves more than the area under the current scope of work, the entire area served by that unit must be re-balanced and recommissioned.

1.10 EQUIPMENT CAPACITIES

- A. Capacities shown for equipment in the specifications and on the drawings are the minimum acceptable. No equipment shall be considered as an alternate that has capacities or performance less than that of design equipment.
- B. All equipment shall give the specified capacity and performance at the job-site elevation. Manufacturers' standard ratings shall be adjusted accordingly. All capacities and performances listed on drawings or in specifications are for job-site conditions.

1.11 SEISMIC REQUIREMENTS FOR EQUIPMENT

- A. All equipment shall be furnished structurally adequate to withstand seismic forces as outlined in the International Building Code. Refer to section Mechanical Vibration Controls and Seismic Restraints. Equipment bases shall be designed for direct attachment of seismic snubbers and/or seismic anchors.

1.12 COOPERATION WITH OTHER TRADES

- A. The Contractor shall refer to other drawings and parts of this specification that cover work of other trades that is carried on in conjunction with the mechanical work such that all work can proceed without interference resulting from lack of coordination.
- B. The Contractor shall properly size and locate all openings, chases, sleeves, equipment bases, and accesses. He shall provide accurate wiring diagrams to the Electrical Contractor for all equipment furnished under this Division.
- C. The ceiling cavity must be carefully reviewed and coordinated with all trades. In the event of conflict, the installation of the mechanical equipment and piping shall be in the following order: plumbing, waste, and soil lines; supply, return, and exhaust ductwork; water piping; medical gases; fire protection piping; and pneumatic control piping.
- D. The mechanical Contractor shall insure that the installation of all piping, ducts and equipment is in compliance with Articles 110-16 and 384-4 of the National Electrical Code relative to proper clearances in front of and over all electrical panels and equipment. No piping or ductwork will be allowed to run over electrical panel.

1.13 RESPONSIBILITY OF CONTRACTOR

- A. The Contractor is responsible for the installation of a satisfactory piece of work in accordance with the true intent of the drawings and specifications. He shall provide, as a part of his work and without expense, all incidental items required even though these items are not particularly specified or indicated. The installation shall be made so that its several component parts will function together as a workable system and shall be left with all equipment properly adjusted and in working order. The Contractor shall familiarize the Owner's Representative with maintenance and lubrication instructions as prepared by the Contractor and shall explain and fully instruct him relative to operating, servicing, and maintenance of them.
- B. If a conflict arises between the drawings and the specifications the most stringent procedure/action shall be followed. A clarification to the engineer will help to determine the course of action to be taken. If a conflict arises between specification sections the engineer will determine which course of action is to be followed.

1.14 PIPE AND DUCT OPENINGS AND EQUIPMENT RECESSES

- A. Pipe and duct chases, openings, and equipment recesses shall be provided by others only if shown on architectural or structural drawings. All openings for the mechanical work, except where plans and specifications indicate otherwise, shall be provided as work of this Division. Include openings information with coordination drawings.
- B. Whether chases, recesses, and openings are provided as work of this Division or by others, this Contractor shall supervise their construction and be responsible for the correct size and location even though detailed and dimensioned on the drawings. This Contractor shall pay for all necessary cutting, repairing, and finishing if any are left out or incorrectly made. All necessary openings thru existing walls, ceilings, floors, roofs, etc. shall be provided by this Contractor unless indicated otherwise by the drawing and/or specifications.

1.15 UNFIT OR DAMAGED WORK

- A. Any part of this installation that fails, is unfit, or becomes damaged during construction, shall be replaced or otherwise made good. The cost of such remedy shall be the responsibility of this Division.

1.16 WORKMANSHIP

- A. Workmanship shall be the best quality of its kind for the respective industries, trades, crafts, and practices, and shall be acceptable in every respect to the Owner's representative. Nothing contained herein shall relieve the Contractor from making good and perfect work in all details in construction.

1.17 SAFETY REGULATION

- A. The Contractor shall comply with all local, Federal, and OSHA safety requirements in performance with this work. (See General Conditions). This Contractor shall be required to provide equipment, supervision, construction, procedures, and all other necessary items to assure safety to life and property.

1.18 ELECTRICAL SERVICES

- A. All equipment control wiring and all automatic temperature control wiring including all necessary contacts, relays, and interlocks, whether low or line voltage, except power wiring, shall be furnished and installed as work of this Division unless shown to be furnished by Division 26. All such wiring shall be in conduit as required by electrical codes. Wiring in the mechanical rooms, fans rooms and inaccessible ceilings and walls shall be installed in conduit as well. Installation of any and all wiring done under Division 21, 22 and 23 shall be in accordance with the requirements of Division 26, Electrical.
- B. All equipment that requires an electrical connection shall be furnished so that it will operate properly and deliver full capacity on the electrical service available.
- C. Refer to the electrical control equipment and wiring shown on the diagrams. Any changes or additions required by specific equipment furnished shall be the complete responsibility of the Contractor furnishing the equipment.
- D. The Mechanical Contractor must coordinate with the Electrical Contractor to insure that all required components of control work are included and fully understood. No additional cost shall accrue to the Owner as a result of lack of such coordination.

1.19 WORK, MATERIALS, AND QUALITY OF EQUIPMENT

- A. Unless otherwise specified, all materials shall be new and of the best quality of their respective kinds and all labor shall be done in a most thorough and workmanlike manner.
- B. Products or equipment of any of the manufacturers cited herein or any of the products approved by the Addenda may be used. However, where lists of products are cited herein, the one first listed in the design equipment used in drawings and schedules to establish size, quality, function, and capacity standards. If other than design equipment is used, it shall be carefully checked for access to equipment, electrical and control requirements, valving, and piping. Should changes or additions occur in piping, valving, electrical work, etc., or if the work of other Contractors would be revised by the alternate equipment, the cost of all changes shall be borne as work of this Division.

- C. The Execution portions of the specifications specify what products and materials may be used. Any products listed in the Product section of the specification that are not listed in the Execution portion of the specification may not be used without written approval by the Engineer.
- D. The access to equipment shown on the drawings is the minimum acceptable space requirements. No equipment that reduces or restricts accessibility to this or any other equipment will be considered.
- E. All major items of equipment are specified in the equipment schedules on the drawings or in these specifications and shall be furnished complete with all accessories normally supplied with the catalog item listed and all other accessories necessary for a complete and satisfactory installation.
- F. All welders shall be certified in accordance with Section IX of the ASME Boiler and Pressure Vessel Code, latest Edition.

1.20 PROTECTION AGAINST WEATHER AND STORING OF MATERIALS

- A. All equipment and materials shall be properly stored and protected against moisture, dust, and wind. Coverings or other protection shall be used on all items that may be damaged or rusted or may have performance impaired by adverse weather or moisture conditions. Damage or defect developing before acceptance of the work shall be made good at the Contractor's expense.
- B. All open duct and pipe openings shall be adequately covered at all times.

1.21 INSTALLATION CHECK

- A. An experienced, competent, and authorized representative of the manufacturer or supplier of each item of equipment indicated in the equipment schedule and the seismic supplier shall visit the site of the work and inspect, check, adjust if necessary, and approve the equipment installation. In each case, the equipment supplier's representative shall be present when the equipment is placed in operation. The equipment supplier's representative shall revisit the job site as often as necessary until all trouble is corrected and the equipment installation and operation is satisfactory to the Engineer.
- B. Each equipment supplier's representative shall furnish to the Owner, through the Engineer, a written report certifying that the equipment (1) has been properly installed and lubricated; (2) is in accurate alignment; (3) is free from any undue stress imposed by connecting piping or anchor bolts; and, (4) has been operated under full load conditions and that it operated satisfactorily.
- C. All costs for this work shall be included in the prices quoted by equipment suppliers.

1.22 EQUIPMENT LUBRICATION

- A. The Contractor shall properly lubricate all pieces of equipment before turning the building over to the Owner. A linen tag shall be attached to each piece of equipment, showing the date of lubrication and the lubricant used. No equipment shall be started until it is properly lubricated.
- B. Necessary time shall be spent with the Owner's Representative to thoroughly familiarize him with all necessary lubrications and maintenance that will be required of him.
- C. Detergent oil as used for automotive purposes shall not be used for this work.

1.23 CUTTING AND PATCHING

- A. No cutting or drilling in structural members shall be done without written approval of the Architect. The work shall be carefully laid out in advance, and cutting, channeling, chasing, or drilling of floors, walls, partitions, ceilings, or other surfaces necessary for the mechanical work shall be carefully done. Any damage to building, piping, or equipment shall be repaired by professional plasterers, masons, concrete workers, etc., and all such work shall be paid for as work of this Division.
- B. When concrete, grading, etc., is disturbed, it shall be restored to original condition as described in the applicable Division of this Specification.

1.24 EXCAVATION AND BACKFILLING

- A. All necessary excavations and backfilling for the Mechanical phase of this project shall be provided as work of this Division. Trenches for all underground pipelines shall be excavated to the required depths. The bottom of trenches shall be compacted hard and graded to obtain required fall. Backfill shall be placed in horizontal layers, not exceeding 12 inches in thickness, and properly moistened. Each layer shall be compacted, by suitable equipment, to a density of not less than 95 percent as determined by ASTM D-1557. After pipelines have been tested, inspected, and approved, the trench shall be backfilled with selected material. Excess earth shall be hauled from the job site. Fill materials approved by the Architect shall be provided as work of this Division.
- B. No trenches shall be cut near or under any footings without consultation first with the Architect's office. Any trenches or excavations more than 30 inches deep shall be tapered, shored, covered, or otherwise made absolutely safe so that no vehicle or persons can be injured by falling into such excavations, or in any way be harmed by cave-ins, shifting earth, rolling rocks, or by drowning. This protection shall be extended to all persons approaching excavation related to this work whether or not such persons are authorized to be in the vicinity of the construction.

1.25 ACCESS

- A. Provide access doors in walls, ceilings and floors by this division unless otherwise noted. For access to mechanical equipment such as valves, dampers, VAV boxes, fans, controls, etc. Refer to Division 8 for door specifications. All access doors shall be 24" x 24" unless otherwise indicated or required. Coordinate location of doors with the Architect prior to installation. . If doors are not specified in Division 8, provide the following: Doors in ceilings and wall shall be equal to JR Smith No. 4760 bonderized and painted. Doors in tile walls shall be equal to JR Smith No. 4730 chrome plated. Doors in floors shall be equal to JR Smith No. 4910
- B. Valves: Valve must be installed in locations where access is readily available. If access is compromised, as judged by the Mechanical Engineer, these valves shall be relocated where directed at the Contractors expense.
- C. Equipment: Equipment must be installed in locations and orientations so that access to all components requiring service or maintenance will not be compromised. If access is compromised, as judged by the Mechanical Engineer, the contractor shall modify the installation as directed by the Engineer at the Contractors expense.
- D. It is the responsibility of this division to install terminal boxes, valves and all other equipment and devices so they can be accessed. If any equipment or devices are installed so they cannot be accessed on a ladder a catwalk and ladder system shall be installed above the ceiling to access and service this equipment.
- E. Fans with 3 HP and above, which are elevated such that the distance from floor to any maintenance point is 6-feet or higher, shall have an appropriate access platform with permanent ladders or steps designed and shown on the design drawings.

1.26 CONCRETE BASES AND INSERTS

- A. Bases: The concrete bases shall be provided and installed as work by this division. This Division shall be responsible for the proper size and location of bases and shall furnish all required anchor bolts and sleeves with templates to be installed as work of Division 03, Concrete.
- B. All floor-mounted mechanical equipment shall be set on 6-inch high concrete bases, unless otherwise noted or shown on drawings. Such bases shall extend 6 inches beyond equipment or mounting rails on all sides or as shown on the drawings and shall have a 1-inch beveled edge all around.
- C. Inserts: Where slotted or other types of inserts required for this work are to be cast into concrete, they shall be furnished as work of this Division
- D. Concrete inserts and pipe support systems shall be equal to Unistrut P3200 series for all piping where more than one pipe is suspended at a common location. Spacing of the inserts shall match the size and type of pipe and of ductwork being supported. The Unistrut insert and pipe support system shall include all inserts, vertical supports, horizontal support members, clamps, hangers, rollers, bolts, nuts, and any other accessory items for a complete pipe-supporting system.

1.27 CLEANING AND PAINTING

- A. Cleaning: After all tests and adjustments have been made and all systems pronounced satisfactory for permanent operation, this Contractor shall clean all exposed piping, ductwork, insulated members, fixture, and equipment installed under this Section and leave them ready for painting. He shall refinish any damaged finish and leave everything in proper working order. The Contractor shall remove all stains or grease marks on walls, floors, glass, hardware, fixtures, or elsewhere, caused by his workman or for which he is responsible. He shall remove all stickers on plumbing fixtures, do all required patching up and repair all work of others damaged by this division of the work, and leave the premises in a clean and orderly condition.
- B. Painting: Painting of exposed pipe, insulated pipe, ducts, or equipment is work of Division 09, Exterior and Interior Painting.
- C. Mechanical Contractor: All equipment which is to be furnished in factory prefinished conditions by the mechanical Contractor shall be left without mark, scratch, or impairment to finish upon completion of job. Any necessary refinishing to match original shall be done. Do not paint over nameplates, serial numbers, or other identifying marks.
- D. Removal of Debris, Etc: Upon completion of this division of the work, remove all surplus material and rubbish resulting from this work, and leave the premises in a clean and orderly condition.

1.28 CONTRACT COMPLETION

- A. Incomplete and Unacceptable Work: If additional site visits or design work is required by the Engineer or Architect because of the use of incomplete or unacceptable work by the Contractor, then the Contractor shall reimburse the Engineer and Architect for all additional time and expenses involved.
- B. Maintenance Instructions: The Contractor shall furnish the Owner complete printed and illustrated operating and maintenance instructions covering all units of mechanical equipment, together with parts lists.
- C. Instructions To Owner's Representatives: In addition to any detailed instructions called for, the mechanical Contractor must provide, without expense to the Owner, competent instructors to

train the Owner's representatives who will be in charge of the apparatus and equipment, in the care, adjustment, and operation of all parts on the heating, air conditioning, ventilating, plumbing, fire protection, and automatic temperature control equipment. Instruction dates shall be scheduled at time of final inspection. A written report specifying times, dates, and name of personnel instructed shall be forwarded to the Architect. A minimum of four 8-hour instruction periods shall be provided. The instruction periods will be broken down to shorter periods when requested by the Owner. The total instruction hours shall not reduced. The ATC Contractor shall provide 4 hours of instructions. The remaining hours shall be divided between the mechanical and sheet metal Contractor.

- D. Guarantee: By the acceptance of any contract award for the work herein described or shown on the drawings, the Contractor assumes the full responsibility imposed by the guarantee as set forth herein and in the General Conditions, and should protect himself through proper guarantees from equipment and special equipment Contractors and from subcontractors as their interests may appear.
- E. The guarantee so assumed by the Contractor and as work of this Section is as follows:
1. That the entire mechanical system, including plumbing, heating, and air-conditioning system shall be quiet in operation.
 2. That the circulation of water shall be complete and even.
 3. That all pipes, conduit, and connections shall be perfectly free from foreign matter and pockets and that all other obstructions to the free passage of air, water, liquid, sewage, and vent shall be removed.
 4. That he shall make promptly and free of charge, upon notice from the Owner, any necessary repairs due to defective workmanship or materials that may occur during a period of one year from date of Substantial Completion.
 5. That all specialties, mechanical, and patent devices incorporated in these systems shall be adjusted in a manner that each shall develop its maximum efficiency in the operation of the system; i.e., diffusers shall deliver the designed amount of air shown on drawings, thermostats shall operate to the specified limits, etc.
 6. All equipment and the complete mechanical, ductwork, piping and plumbing systems shall be guaranteed for a period of one year from the date of the Architect's Certificate of Substantial Completion, this includes all mechanical, ductwork, piping and plumbing equipment and products and is not limited to boiler, chillers, coils, fans, filters etc. Any equipment supplier not willing to comply with this guarantee period shall not submit a bid price for this project. The Contractor shall be responsible for a 100-percent guarantee for the system and all items of equipment for this period. If the contractor needs to provide temporary heating or cooling to the building and or needs to insure systems are installed properly and or to meet the project schedule the guaranteed of all systems and equipment shall be as indicated above, on year from the date of the Architect's Certificate of Substantial Completion.
 7. All filters used during construction shall be replaced just before equipment is turned over to the Owner, and all required equipment and parts shall be oiled. Any worn parts shall also be replaced.
 8. If any systems or equipment is used for temporary heating or cooling the systems shall be protected so they remain clean. I.e. if the ductwork systems are used temporary filters and a filter holder (not duct-taped to ducts or grilles) shall be installed to insure the systems and the equipment remain clean.

1.29 CURBS

- A. Unless otherwise noted in these specifications or on the documents all roof curbs for all equipment are to be provided by Division 22 and 23.

1.30 TEST RUN

- A. The Mechanical Contractor shall operate the mechanical system for a minimum of 30 days to prove the operation of the system.

1.31 EQUIPMENT STARTUP AND CHECKOUT:

- A. Each major piece of equipment shall be started and checked out by an authorized representative of the equipment manufacturer. A certificate indicating the equipment is operating to the satisfaction of the manufacturer shall be provided and shall be included in the commissioning report.
- B. This contractor shall coordinate commissioning procedures and activities with the commissioning agent.

1.32 DEMOLITION

- A. General: Demolish and remove existing construction only to the extent required by new construction and as indicated. Use methods required to complete the Work within limitations of governing regulations and as follows:
- B. Proceed with demolition systematically, from higher to lower level. Complete selective demolition operations above each floor or tier before disturbing supporting members on the next lower level.
- C. Neatly cut openings and holes plumb, square, and true to dimensions required. Use cutting methods least likely to damage construction to remain or adjoining construction. Use hand tools or small power tools designed for sawing or grinding, not hammering and chopping, to minimize disturbance of adjacent surfaces. Temporarily cover openings to remain.
- D. Cut or drill from the exposed or finished side into concealed surfaces to avoid marring existing finished surfaces.
- E. Do not use cutting torches until work area is cleared of flammable materials. At concealed spaces, such as duct and pipe interiors, verify condition and contents of hidden space before starting flame-cutting operations. Maintain portable fire-suppression devices during flame-cutting operations.
- F. Maintain adequate ventilation when using cutting torches.
- G. Remove decayed, vermin-infested, or otherwise dangerous or unsuitable materials and promptly dispose of off-site.
- H. Remove structural framing members and lower to ground by method suitable to avoid free fall and to prevent ground impact or dust generation.
- I. Locate selective demolition equipment and remove debris and materials so as not to impose excessive loads on supporting walls, floors, or framing.
- J. Dispose of demolished items and materials promptly.
- K. Return elements of construction and surfaces that are to remain to condition existing before selective demolition operations began.
- L. Existing Facilities: Comply with building manager's requirements for using and protecting elevators, stairs, walkways, loading docks, building entries, and other building facilities during selective demolition operations.
- M. Concrete: Demolish in sections. Cut concrete full depth at junctures with construction to remain and at regular intervals, using power-driven saw, then remove concrete between saw cuts.
- N. Masonry: Demolish in small sections. Cut masonry at junctures with construction to remain, using power-driven saw, and then remove masonry between saw cuts.

- O. Concrete Slabs-on-Grade: Saw-cut perimeter of area to be demolished, then break up and remove.
- P. Air-Conditioning Equipment: Remove equipment without releasing refrigerants.

END OF SECTION 23 0100

SECTION 23 0150

TEMPORARY USE OF EQUIPMENT AND SYSTEMS

PART 1 - GENERAL

1.1 SUMMARY

- A. This section includes requirements for temporary use of equipment and systems and any other items that are used during the construction of the project.

1.2 EQUIPMENT OR SYSTEMS NEEDED TO OPERATE BEFORE CONTRACT COMPLETION

- A. If the contractor needs to provide temporary heating or cooling to the building and or needs to ensure systems are installed properly for start up and or to meet the project schedule the guaranteed of all systems and equipment shall be for one year from the date of the Architect's Certificate of Substantial Completion.

All equipment and the complete mechanical, ductwork, piping and plumbing systems shall be guaranteed for a period of one year from the date of the Architect's Certificate of Substantial Completion, this includes all mechanical, ductwork, piping and plumbing equipment and products and is not limited to boiler, chillers, coils, fans, filters etc. Any contractor or equipment supplier who is not willing to comply with this guarantee period shall not submit a bid price for this project. The Contractor shall be responsible for a 100-percent guarantee for the systems and all items of equipment for this period.

All filters used during construction shall be replaced just before equipment is turned over to the Owner, and all required equipment and parts shall be oiled. Any worn parts shall also be replaced.

If any systems or equipment is used for temporary heating or cooling the systems shall be protected so they remain clean. I.e. if the ductwork systems are used temporary filters and a filter holder (not duct-taped to ducts or grilles) shall be installed to insure the systems and the equipment remain clean. All return air openings shall be protected with a metal filter frame and filters.

1.3 TEMPORARY EQUIPMENT OR SYSTEM SUBMITTALS

- A. If it is determined by the project or contractor that equipment or systems are needed to operate to provide heating, cooling or other needed services this division shall submit a document indicating what measures will be taken to insure the safe and proper operation of the equipment, systems and personal associated with the operation, this document shall be submitted to the engineer for approval. This plan shall show connections of equipment, utility hookups (if required) staging areas etc.

1.4 QUALITY ASSURANCE

- A. Electric Service: Comply with NECA, NEMA, and UL standards and regulations for temporary electric service. Install service to comply with NFPA 70.
- B. Tests and Inspections: Arrange for authorities having jurisdiction to test and inspect each temporary utility before use. Obtain required certifications and permits.

C. Accessible Temporary Egress: Comply with applicable provisions in the U.S. Architectural & Transportation Barriers Compliance Board's ADA-ABA Accessibility Guidelines.

D. SMACNA: The latest standard from SSMACNA shall apply.

1.5 PROJECT CONDITIONS

A. Temporary Use of equipment or systems: Engage installer of each permanent service to assume responsibility for operation, maintenance, and protection of each permanent service during its use until the facility has been accepted by the owner regardless of previously assigned responsibilities.

PART 2 - PRODUCTS

2.1 EQUIPMENT

A. Fire Extinguishers: Portable, UL rated; with class and extinguishing agent as required by locations and classes of fire exposures.

B. HVAC Equipment: Unless Owner authorizes use of permanent HVAC system, provide vented, self-contained, liquid-propane-gas or fuel-oil heaters and cooling units if required with individual space thermostatic control.

1. Use of gasoline-burning space heaters, open-flame heaters, or salamander-type heating units is prohibited.

2. Heating Units: Listed and labeled for type of fuel being consumed, by a testing agency acceptable to authorities having jurisdiction, and marked for intended use.

3. Permanent HVAC System: If Owner authorizes use of permanent HVAC system for temporary use during construction, provide filters with MERV of 8 at each return air opening in system and remove at end of construction. These filters are to be installed in a filter housing frame and are not to be duct taped. Clean HVAC system as required in Division 01 Section "Closeout Procedures."

Commented [BB1]: 017700 CLOSEOUT PROCEDURES

PART 3 - EXECUTION

3.1 INSTALLATION, GENERAL

A. Locate equipment where they will serve Project adequately and result in minimum interference with performance of the Work. Relocate and modify equipment and systems as required by progress of the Work.

1. Locate equipment to limit site disturbance as specified in Division 01 Section "Summary."

Commented [BB2]: 011000 SUMMARY

3.2 TEMPORARY UTILITY INSTALLATION

A. General: Install temporary service or connect to existing service.

1. Arrange with utility company, Owner, and existing users for time when service can be interrupted, if necessary, to make connections for temporary services.

B. Water Service: Install water service and distribution piping in sizes and pressures adequate for construction.

- C. Heating and Cooling: Provide temporary heating and cooling required by construction activities for curing or drying of completed installations or for protecting installed construction from adverse effects of low temperatures or high humidity. Select equipment that will not have a harmful effect on completed installations or elements being installed.
- D. Ventilation and Humidity Control: Provide temporary ventilation required by construction activities for curing or drying of completed installations or for protecting installed construction from adverse effects of high humidity. Select equipment that will not have a harmful effect on completed installations or elements being installed. Coordinate ventilation requirements to produce ambient condition required and minimize energy consumption.

3.3 OPERATION, TERMINATION, AND REMOVAL

- A. Maintenance: Maintain equipment and systems in good operating condition until removal.
 - 1. Maintain operation of temporary enclosures, heating, cooling, humidity control, ventilation, and similar equipment and systems on a 24-hour basis where required to achieve indicated results and to avoid possibility of damage.
- B. Termination and Removal: Remove each temporary facility or equipment when need for its service has ended, when it has been replaced by authorized use of a permanent facility, or no later than Substantial Completion. Complete or, if necessary, restore permanent construction that may have been delayed because of interference with temporary facility. Repair damaged Work, clean exposed surfaces, and replace construction that cannot be satisfactorily repaired.
 - 1. Materials equipment that constitute temporary equipment are property of Contractor.
 - 2. At Substantial Completion, repair, renovate, and clean permanent equipment and systems used during construction period. Comply with final cleaning requirements specified in Division 01 Section "Closeout Procedures."

Commented [BB3]: 017700 CLOSEOUT PROCEDURES

3.4 EQUIPMENT STARTUP AND CHECKOUT:

- A. Each major piece of equipment shall be started and checked out by an authorized representative of the equipment manufacturer at substantial completion. A certificate indicating the equipment is operating to the satisfaction of the manufacturer shall be provided and shall be included in the commissioning report.

END OF SECTION 23 0150

THIS PAGE LEFT BLANK INTENTIONALLY

SECTION 23 0500

COMMON WORK RESULTS FOR HVAC

PART 1 - GENERAL

1.1 RELATED DOCUMENTS

- A. Drawings and general provisions of the Contract, including General and Supplementary Conditions and Division 01 Specification Sections, apply to this Section.

1.2 SUMMARY

- A. This Section includes the following:
 - 1. Piping materials and installation instructions common to most piping systems.
 - 2. Transition fittings.
 - 3. Dielectric fittings.
 - 4. Mechanical sleeve seals.
 - 5. Sleeves.
 - 6. Escutcheons.
 - 7. Grout.
 - 8. Equipment installation requirements common to equipment sections.
 - 9. Painting and finishing.
 - 10. Concrete bases.
 - 11. Supports and anchorages.
 - 12. Link-Seal

1.3 DEFINITIONS

- A. Finished Spaces: Spaces other than mechanical and electrical equipment rooms, furred spaces, pipe and duct chases, unheated spaces immediately below roof, spaces above ceilings, unexcavated spaces, and crawlspaces.
- B. Exposed, Interior Installations: Exposed to view indoors. Examples include finished occupied spaces, mechanical equipment rooms, accessible pipe shafts, accessible plumbing chases, and accessible tunnels.
- C. Exposed, Exterior Installations: Exposed to view outdoors or subject to outdoor ambient temperatures and weather conditions. Examples include rooftop locations.
- D. Concealed, Interior Installations: Concealed from view and protected from physical contact by building occupants. Examples include above ceilings and chases.
- E. Concealed, Exterior Installations: Concealed from view and protected from weather conditions and physical contact by building occupants but subject to outdoor ambient temperatures. Examples include installations within unheated shelters.
- F. The following are industry abbreviations for plastic materials:
 - 1. CPVC: Chlorinated polyvinyl chloride plastic.
 - 2. PVC: Polyvinyl chloride plastic.
- G. The following are industry abbreviations for rubber materials:

1. EPDM: Ethylene-propylene-diene terpolymer rubber.
2. NBR: Acrylonitrile-butadiene rubber.

1.4 SUBMITTALS

- A. Product Data: For the following:
 1. Transition fittings.
 2. Dielectric fittings.
 3. Mechanical sleeve seals.
 4. Escutcheons.
- B. Welding certificates.

1.5 QUALITY ASSURANCE

- A. Steel Support Welding: Qualify processes and operators according to AWS D1.1, "Structural Welding Code--Steel."
- B. Steel Pipe Welding: Qualify processes and operators according to ASME Boiler and Pressure Vessel Code: Section IX, "Welding and Brazing Qualifications."
 1. Comply with provisions in ASME B31 Series, "Code for Pressure Piping."
 2. Certify that each welder has passed AWS qualification tests for welding processes involved and that certification is current.
- C. Electrical Characteristics for HVAC Equipment: Equipment of higher electrical characteristics may be furnished provided such proposed equipment is approved in writing and connecting electrical services, circuit breakers, and conduit sizes are appropriately modified. If minimum energy ratings or efficiencies are specified, equipment shall comply with requirements.

1.6 DELIVERY, STORAGE, AND HANDLING

- A. Deliver pipes and tubes with factory-applied end caps. Maintain end caps through shipping, storage, and handling to prevent pipe end damage and to prevent entrance of dirt, debris, and moisture.
- B. Store plastic pipes protected from direct sunlight. Support to prevent sagging and bending.

1.7 COORDINATION

- A. Arrange for pipe spaces, chases, slots, and openings in building structure during progress of construction, to allow for HVAC installations.
- B. Coordinate installation of required supporting devices and set sleeves in poured-in-place concrete and other structural components as they are constructed.
- C. Coordinate requirements for access panels and doors for HVAC items requiring access that are concealed behind finished surfaces. Access panels and doors are specified in Division 08 Section "Access Doors and Frames."

PART 2 - PRODUCTS

2.1 MANUFACTURERS

- A. In other Part 2 articles where subparagraph titles below introduce lists, the following requirements apply for product selection:
 - 1. Manufacturers: Subject to compliance with requirements, provide products by the manufacturers specified.

2.2 PIPE, TUBE, AND FITTINGS

- A. Refer to individual Division 23 piping Sections for pipe, tube, and fitting materials and joining methods.
- B. Pipe Threads: ASME B1.20.1 for factory-threaded pipe and pipe fittings.

2.3 JOINING MATERIALS

- A. Refer to individual Division 23 piping Sections for special joining materials not listed below.
- B. Pipe-Flange Gasket Materials: Suitable for chemical and thermal conditions of piping system contents.
 - 1. ASME B16.21, nonmetallic, flat, asbestos-free, 1/8-inch maximum thickness unless thickness or specific material is indicated.
 - a. Full-Face Type: For flat-face, Class 125, cast-iron and cast-bronze flanges.
 - b. Narrow-Face Type: For raised-face, Class 250, cast-iron and steel flanges.
 - 2. AWWA C110, rubber, flat face, 1/8 inch thick, unless otherwise indicated; and full-face or ring type, unless otherwise indicated.
- C. Flange Bolts and Nuts: ASME B18.2.1, carbon steel, unless otherwise indicated.
- D. Solder Filler Metals: ASTM B 32, lead-free alloys. Include water-flushable flux according to ASTM B 813.
- E. Brazing Filler Metals: AWS A5.8, BCuP Series, copper-phosphorus alloys for general-duty brazing, unless otherwise indicated; and AWS A5.8, BAg1, silver alloy for refrigerant piping, unless otherwise indicated.
 - 1. Use of flux is required in all brazing applications. The flux used is to be a black brazing flux that does not contain boric acid and conforms to AWS A5.31 class FB3-C.
- F. Welding Filler Metals: Comply with AWS D10.12 for welding materials appropriate for wall thickness and chemical analysis of steel pipe being welded.

2.4 TRANSITION FITTINGS

- A. Plastic-to-Metal Transition Fittings: CPVC and PVC one-piece fitting with manufacturer's Schedule 80 equivalent dimensions; one end with threaded brass insert, and one solvent-cement-joint end.

1. Manufacturers:
 - a. Eslon Thermoplastics.
- B. Plastic-to-Metal Transition Adaptors: One-piece fitting with manufacturer's SDR 11 equivalent dimensions; one end with threaded brass insert, and one solvent-cement-joint end.
 1. Manufacturers:
 - a. Thompson Plastics, Inc.

2.5 DIELECTRIC FITTINGS

- A. General: Assembly or fitting with insulating material isolating joined dissimilar metals, to prevent galvanic action and stop corrosion.
- B. Description: Combination of copper alloy and ferrous; threaded, solder, plain, and weld-neck end types and matching piping system materials.
- C. Insulating Material: Suitable for system fluid, pressure, and temperature.
- D. Dielectric Unions: Factory-fabricated, union assembly, for 250-psig minimum working pressure at 180 deg F.
- E. Dielectric Flanges: Factory-fabricated, companion-flange assembly, for 150- or 300-psig minimum working pressure as required to suit system pressures.
- F. Dielectric-Flange Insulation Kits: Field-assembled, companion-flange assembly, full-face or ring type. Components include neoprene or phenolic gasket, phenolic or polyethylene bolt sleeves, phenolic washers, and steel backing washers.
 1. Provide separate companion flanges and steel bolts and nuts for 150- or 300-psig minimum working pressure as required to suit system pressures.
- G. Dielectric Couplings: Galvanized-steel coupling with inert and noncorrosive, thermoplastic lining; threaded ends; and 300-psig minimum working pressure at 225 deg F.
- H. Dielectric Nipples: Electroplated steel nipple with inert and noncorrosive, thermoplastic lining; plain, threaded, or grooved ends; and 300-psig minimum working pressure at 225 deg F.
 1. Manufacturers:
 - a. Capitol Manufacturing Co.
 - b. Central Plastics Company.
 - c. Watts Industries, Inc.; Water Products Div

2.6 MECHANICAL SLEEVE SEALS

- A. Description: Modular sealing element unit, designed for field assembly, to fill annular space between pipe and sleeve.
 1. Manufacturers:
 - a. Advance Products & Systems, Inc.
 - b. Calpico, Inc.
 - c. Metraflex Co.
 - d. Pipeline Seal and Insulator, Inc.

2. Sealing Elements: EPDM interlocking links shaped to fit surface of pipe. Include type and number required for pipe material and size of pipe.
3. Pressure Plates: Stainless steel. Include two for each sealing element.
4. Connecting Bolts and Nuts: Stainless steel of length required to secure pressure plates to sealing elements. Include one for each sealing element.

2.7 SLEEVES

- A. Galvanized-Steel Sheet: 0.0239-inch minimum thickness; round tube closed with welded longitudinal joint.
- B. Steel Pipe: ASTM A 53, Type E, Grade B, Schedule 40, galvanized, plain ends.
- C. Cast Iron: Cast or fabricated "wall pipe" equivalent to ductile-iron pressure pipe, with plain ends and integral waterstop, unless otherwise indicated.
- D. Stack Sleeve Fittings: Manufactured, cast-iron sleeve with integral clamping flange. Include clamping ring and bolts and nuts for membrane flashing.
 1. Underdeck Clamp: Clamping ring with set screws.
- E. Molded PVC: Permanent, with nailing flange for attaching to wooden forms.
- F. PVC Pipe: ASTM D 1785, Schedule 40.

2.8 ESCUTCHEONS

- A. Description: Manufactured wall and ceiling escutcheons and floor plates, with an ID to closely fit around pipe, tube, and insulation of insulated piping and an OD that completely covers opening.
- B. One-Piece, Deep-Pattern Type: Deep-drawn, box-shaped brass with polished chrome-plated finish.
- C. One-Piece, Cast-Brass Type: With set screw.
 1. Finish: Polished chrome-plated and rough brass.
- D. One-Piece, Stamped-Steel Type: With set screw or spring clips and chrome-plated finish.
- E. Split-Plate, Stamped-Steel Type: With concealed hinge, set screw or spring clips, and chrome-plated finish.

2.9 GROUT

- A. Description: ASTM C 1107, Grade B, non-shrink and nonmetallic, dry hydraulic-cement grout.
 1. Characteristics: Post-hardening, volume-adjusting, non-staining, noncorrosive, nongaseous, and recommended for interior and exterior applications.
 2. Design Mix: 5000-psi, 28-day compressive strength.
 3. Packaging: Premixed and factory packaged.

2.10 LINK-SEAL MODULAR SEAL PRESSURE PLATES

- A. Link-Seal® modular seal pressure plates shall be molded of glass reinforced Nylon Polymer with the following properties:
 - 1. Izod Impact - Notched = 2.05ft-lb/in. per ASTM D-256
 - 2. Flexural Strength @ Yield = 30,750 psi per ASTM D-790
 - 3. Flexural Modulus = 1,124,000 psi per ASTM D-790
 - 4. Elongation Break = 11.07% per ASTM D-638
 - 5. Specific Gravity = 1.38 per ASTM D-792
- B. Models LS200-275-300-315 shall incorporate the most current Link-Seal® Modular Seal design modifications and shall include an integrally molded compression assist boss on the top (bolt entry side) of the pressure plate, which permits increased compressive loading of the rubber sealing element. Models 315-325-340-360-400-410-425-475-500-525-575-600 shall incorporate an integral recess known as a "Hex Nut Interlock" designed to accommodate commercially available fasteners to insure proper thread engagement for the class and service of metal hardware. All pressure plates shall have a permanent identification of the manufacturer's name molded into it.
- C. For fire service, pressure plates shall be steel with 2-part Zinc Dichromate Coating.
- D. Link-Seal® Modular Seal Hardware: All fasteners shall be sized according to latest Link-Seal® modular seal technical data. Bolts, flange hex nuts shall be:
 - 1. 316 Stainless Steel per ASTM F593-95, with a 85,000 psi average tensile strength.

PART 3 - EXECUTION

3.1 PIPING SYSTEMS - COMMON REQUIREMENTS

- A. Install piping according to the following requirements and Division 23 Sections specifying piping systems.
- B. Drawing plans, schematics, and diagrams indicate general location and arrangement of piping systems. Indicated locations and arrangements were used to size pipe and calculate friction loss, expansion, pump sizing, and other design considerations. Install piping as indicated unless deviations to layout are approved on Coordination Drawings.
- C. Install piping in concealed locations, unless otherwise indicated and except in equipment rooms and service areas.
- D. Install piping indicated to be exposed and piping in equipment rooms and service areas at right angles or parallel to building walls. Diagonal runs are prohibited unless specifically indicated otherwise.
- E. Install piping above accessible ceilings to allow sufficient space for ceiling panel removal.
- F. Install piping to permit valve servicing.
- G. Install piping at indicated slopes.
- H. Install piping free of sags and bends.
- I. Install fittings for changes in direction and branch connections.
- J. Install piping to allow application of insulation.

- K. Select system components with pressure rating equal to or greater than system operating pressure.
- L. Install escutcheons for penetrations of walls, ceilings, and floors according to the following:
 - 1. New Piping:
 - a. Piping with Fitting or Sleeve Protruding from Wall: One-piece, deep-pattern type.
 - b. Chrome-Plated Piping: One-piece, cast-brass type with polished chrome-plated finish.
 - c. Insulated Piping: One-piece, stamped-steel type with spring clips.
 - d. Bare Piping at Wall and Floor Penetrations in Finished Spaces: One-piece, cast-brass type with polished chrome-plated finish.
 - e. Bare Piping at Wall and Floor Penetrations in Finished Spaces: One-piece, stamped-steel type.
 - f. Bare Piping at Ceiling Penetrations in Finished Spaces: One-piece or split-casting, cast-brass type with polished chrome-plated finish.
 - g. Bare Piping at Ceiling Penetrations in Finished Spaces: One-piece, stamped-steel type or split-plate, stamped-steel type with concealed hinge and set screw.
- M. Install sleeves for pipes passing through concrete and masonry walls and concrete floor and roof slabs.
- N. Install sleeves for pipes passing through concrete and masonry walls, gypsum-board partitions, and concrete floor and roof slabs.
 - 1. Cut sleeves to length for mounting flush with both surfaces.
 - a. Exception: Extend sleeves installed in floors of mechanical equipment areas or other wet areas 2 inches above finished floor level. Extend cast-iron sleeve fittings below floor slab as required to secure clamping ring if ring is specified.
 - 2. Install sleeves in new walls and slabs as new walls and slabs are constructed.
 - 3. Install sleeves that are large enough to provide 1/4-inch annular clear space between sleeve and pipe or pipe insulation. Use the following sleeve materials:
 - a. PVC Steel Pipe Sleeves: For pipes smaller than NPS 6.
 - b. Steel Sheet Sleeves: For pipes NPS 6 and larger, penetrating gypsum-board partitions.
 - c. Stack Sleeve Fittings: For pipes penetrating floors with membrane waterproofing. Secure flashing between clamping flanges. Install section of cast-iron soil pipe to extend sleeve to 2 inches above finished floor level. Refer to Division 07 Section "Sheet Metal Flashing and Trim" for flashing.
 - 1) Seal space outside of sleeve fittings with grout.
 - 4. Except for underground wall penetrations, seal annular space between sleeve and pipe or pipe insulation, using joint sealants appropriate for size, depth, and location of joint. Refer to Division 07 Section "Joint Sealants" for materials and installation.
- O. Aboveground, Exterior-Wall Pipe Penetrations: Seal penetrations using sleeves and mechanical sleeve seals. Select sleeve size to allow for 1-inch annular clear space between pipe and sleeve for installing mechanical sleeve seals.
 - 1. Install steel pipe for sleeves smaller than 6 inches in diameter.
 - 2. Install cast-iron "wall pipes" for sleeves 6 inches and larger in diameter.

3. Mechanical Sleeve Seal Installation: Select type and number of sealing elements required for pipe material and size. Position pipe in center of sleeve. Assemble mechanical sleeve seals and install in annular space between pipe and sleeve. Tighten bolts against pressure plates that cause sealing elements to expand and make watertight seal.
- P. Underground, Exterior-Wall Pipe Penetrations: Install cast-iron "wall pipes" for sleeves. Seal pipe penetrations using mechanical sleeve seals. Select sleeve size to allow for 1-inch annular clear space between pipe and sleeve for installing mechanical sleeve seals.
1. Mechanical Sleeve Seal Installation: Select type and number of sealing elements required for pipe material and size. Position pipe in center of sleeve. Assemble mechanical sleeve seals and install in annular space between pipe and sleeve. Tighten bolts against pressure plates that cause sealing elements to expand and make watertight seal.
- Q. Fire-Barrier Penetrations: Maintain indicated fire rating of walls, partitions, ceilings, and floors at pipe penetrations. Seal pipe penetrations with firestop materials. Refer to Division 07 Section "Penetration Firestopping" for materials.
- R. Verify final equipment locations for roughing-in.
- S. Refer to equipment specifications in other Sections of these Specifications for roughing-in requirements.

3.2 PIPING JOINT CONSTRUCTION

- A. Join pipe and fittings according to the following requirements and Division 23 Sections specifying piping systems.
- B. Ream ends of pipes and tubes and remove burrs. Bevel plain ends of steel pipe.
- C. Remove scale, slag, dirt, and debris from inside and outside of pipe and fittings before assembly.
- D. Soldered Joints: Apply ASTM B 813, water-flushable flux, unless otherwise indicated, to tube end. Construct joints according to ASTM B 828 or CDA's "Copper Tube Handbook," using lead-free solder alloy complying with ASTM B 32.
- E. Brazed Joints: Construct joints according to AWS's "Brazing Handbook," "Pipe and Tube" Chapter, using copper-phosphorus brazing filler metal complying with AWS A5.8 & a black brazing flux that does not contain boric acid complying with AWS A5.31 class FB3-C.
- F. Threaded Joints: Thread pipe with tapered pipe threads according to ASME B1.20.1. Cut threads full and clean using sharp dies. Ream threaded pipe ends to remove burrs and restore full ID. Join pipe fittings and valves as follows:
1. Apply appropriate tape or thread compound to external pipe threads unless dry seal threading is specified.
 2. Damaged Threads: Do not use pipe or pipe fittings with threads that are corroded or damaged. Do not use pipe sections that have cracked or open welds.
- G. Welded Joints: Construct joints according to AWS D10.12, using qualified processes and welding operators according to Part 1 "Quality Assurance" Article.
- H. Flanged Joints: Select appropriate gasket material, size, type, and thickness for service application. Install gasket concentrically positioned. Use suitable lubricants on bolt threads.

3.3 PIPING CONNECTIONS

- A. Make connections according to the following, unless otherwise indicated:
 - 1. Install unions, in piping NPS 2 and smaller, adjacent to each valve and at final connection to each piece of equipment.
 - 2. Install flanges, in piping NPS 2-1/2 and larger, adjacent to flanged valves and at final connection to each piece of equipment.
 - 3. Dry Piping Systems: Install dielectric unions and flanges to connect piping materials of dissimilar metals.
 - 4. Wet Piping Systems: Install dielectric coupling and nipple fittings to connect piping materials of dissimilar metals.

3.4 EQUIPMENT INSTALLATION - COMMON REQUIREMENTS

- A. Install equipment to allow maximum possible headroom unless specific mounting heights are not indicated.
- B. Install equipment level and plumb, parallel and perpendicular to other building systems and components in exposed interior spaces, unless otherwise indicated.
- C. Install HVAC equipment to facilitate service, maintenance, and repair or replacement of components. Connect equipment for ease of disconnecting, with minimum interference to other installations. Extend grease fittings to accessible locations.
- D. Install equipment to allow right of way for piping installed at required slope.

3.5 PAINTING

- A. Painting of HVAC systems, equipment, and components is specified in Division 09 Sections "Interior Painting" and "Exterior Painting."
- B. Damage and Touchup: Repair marred and damaged factory-painted finishes with materials and procedures to match original factory finish.

3.6 CONCRETE BASES

- A. Concrete Bases: Anchor equipment to concrete base according to equipment manufacturer's written instructions and according to seismic codes at Project.
 - 1. Construct concrete bases of dimensions indicated, but not less than 4 inches larger in both directions than supported unit.
 - 2. Install dowel rods to connect concrete base to concrete floor. Unless otherwise indicated, install dowel rods on 18-inch centers around the full perimeter of the base.
 - 3. Install epoxy-coated anchor bolts for supported equipment that extend through concrete base, and anchor into structural concrete floor.
 - 4. Place and secure anchorage devices. Use supported equipment manufacturer's setting drawings, templates, diagrams, instructions, and directions furnished with items to be embedded.
 - 5. Install anchor bolts to elevations required for proper attachment to supported equipment.
 - 6. Install anchor bolts according to anchor-bolt manufacturer's written instructions.

7. Use 3000-psi, 28-day compressive-strength concrete and reinforcement as specified in Division 03 Section "Cast-in-Place Concrete."

3.7 ERECTION OF METAL SUPPORTS AND ANCHORAGES

- A. Refer to Division 05 Section "Metal Fabrications" for structural steel.
- B. Cut, fit, and place miscellaneous metal supports accurately in location, alignment, and elevation to support and anchor HVAC materials and equipment.
- C. Field Welding: Comply with AWS D1.1.

3.8 GROUTING

- A. Mix and install grout for HVAC equipment base bearing surfaces, pump and other equipment base plates, and anchors.
- B. Clean surfaces that will come into contact with grout.
- C. Provide forms as required for placement of grout.
- D. Avoid air entrapment during placement of grout.
- E. Place grout, completely filling equipment bases.
- F. Place grout on concrete bases and provide smooth bearing surface for equipment.
- G. Place grout around anchors.
- H. Cure placed grout.

3.9 LINK SEAL

- A. Provide Link Seal at all piping penetrations from the outside.

END OF SECTION 23 0500

SECTION 23 0513

COMMON MOTOR REQUIREMENTS FOR HVAC EQUIPMENT

PART 1 - GENERAL

1.1 RELATED DOCUMENTS

- A. Drawings and general provisions of the Contract, including General and Supplementary Conditions and Division 01 Specification Sections, apply to this Section.

1.2 SUMMARY

- A. Section includes general requirements for single-phase and polyphase, general-purpose, horizontal, small and medium, squirrel-cage induction motors for use on ac power systems up to 600 V and installed at equipment manufacturer's factory or shipped separately by equipment manufacturer for field installation.

1.3 COORDINATION

- A. Coordinate features of motors, installed units, and accessory devices to be compatible with the following:
 1. Motor controllers.
 2. Torque, speed, and horsepower requirements of the load.
 3. Ratings and characteristics of supply circuit and required control sequence.
 4. Ambient and environmental conditions of installation location.

PART 2 - PRODUCTS

2.1 GENERAL MOTOR REQUIREMENTS

- A. Comply with requirements in this Section except when the requirements in equipment schedules, other specification sections, drawing notes or in other contract documents are more stringent.
- B. Comply with NEMA MG 1 unless otherwise indicated.
- C. All submitted motors are to be premium efficient motors.

2.2 MOTOR CHARACTERISTICS

- A. Duty: Continuous duty at ambient temperature of 40 deg C and at altitude of 3300 feet above sea level.
- B. Capacity and Torque Characteristics: Sufficient to start, accelerate, and operate connected loads at designated speeds, at installed altitude and environment, with indicated operating sequence, and without exceeding nameplate ratings or considering service factor.
- C. Motors 3/4 HP and larger: Polyphase.

- D. Motors smaller than 3/4 HP: Single phase.
- E. All motors shall have ASTM Grade 5 hardware that is Yellow Zinc-dichromate plated.

2.3 POLYPHASE MOTORS

- A. Description: NEMA MG 1, Design B, medium induction motor.
- B. Efficiency: Premium energy efficient, as defined in NEMA MG 1.
- C. Service Factor: 1.15.
- D. Rotor: Random-wound, squirrel cage.
- E. Bearings: Regreasable, shielded, antifriction ball bearings suitable for radial and thrust loading.
- F. Temperature Rise: Match insulation rating.
- G. Insulation: Class F.
- H. Code Letter Designation:
 - 1. Motors 15 HP and Larger: NEMA starting Code F or Code G.
 - 2. Motors smaller than 15 HP: Manufacturer's standard starting characteristic.
- I. Enclosure Material: Cast iron for motor frame sizes 324T and larger; rolled steel for motor frame sizes smaller than 324T.

2.4 POLYPHASE MOTORS WITH ADDITIONAL REQUIREMENTS

- A. Motors Used with Reduced-Voltage and Multispeed Controllers: Match wiring connection requirements for controller with required motor leads. Provide terminals in motor terminal box, suited to control method.
- B. Motors Used with Variable Frequency Controllers: Ratings, characteristics, and features coordinated with and approved by controller manufacturer.
 - 1. Windings: Copper magnet wire with moisture-resistant insulation varnish, designed and tested to resist transient spikes, high frequencies, and short time rise pulses produced by pulse-width modulated inverters.
 - 2. Premium-Efficient Motors: Class B temperature rise; Class F insulation.
 - 3. Inverter-Duty Motors: Class F temperature rise; Class F insulation.
 - 4. Thermal Protection: Comply with NEMA MG 1 requirements for thermally protected motors.
 - 5. Shaft Grounding Ring: Microfiber type.
 - a. Provide grounded discharge path for VFD induced voltage in the shaft to prevent arching in the motor bearings.
- C. Severe-Duty Motors: Comply with IEEE 841, with 1.15 minimum service factor.

2.5 ELECTRONICALLY COMMUTATED MOTOR (ECM)

- A. Motor enclosures: Open type
- B. Motor to be a DC electronic commutation type motor (ECM).

1. AC induction type motors are not acceptable.
- C. Permanently lubricated motor with heavy duty ball bearing
- D. Internal motor circuitry to convert AC power supplied to the fan to DC power to operate the motor.
- E. Speed controllable to 20% of full speed (80% turndown).
 1. Potentiometer dial mounted at the motor speed controller
 2. 0-10 VDC signal.
- F. 85% efficient at all speeds minimum.
- G. Motors smaller than 2.0 hp.

2.6 SINGLE-PHASE MOTORS

- A. Motors larger than 1/20 hp shall be one of the following, to suit starting torque and requirements of specific motor application:
 1. Permanent-split capacitor.
 2. Split phase.
 3. Capacitor start, inductor run.
 4. Capacitor start, capacitor run.
- B. Bearings: Prelubricated, antifriction ball bearings or sleeve bearings suitable for radial and thrust loading.
- C. Motors 1/20 HP and Smaller: Shaded-pole type.
- D. Thermal Protection: Internal protection to automatically open power supply circuit to motor when winding temperature exceeds a safe value calibrated to temperature rating of motor insulation. Thermal-protection device shall automatically reset when motor temperature returns to normal range, unless otherwise indicated.

PART 3 - EXECUTION (Not Applicable)

END OF SECTION 23 0513

THIS PAGE LEFT BLANK INTENTIONALLY

SECTION 23 0517

SLEEVES AND SLEEVE SEALS FOR HVAC PIPING

PART 1 - GENERAL

1.1 RELATED DOCUMENTS

- A. Drawings and general provisions of the Contract, including General and Supplementary Conditions and Division 01 Specification Sections, apply to this Section.

1.2 SUMMARY

- A. Section Includes:
 1. Sleeves.
 2. Stack-sleeve fittings.
 3. Sleeve-seal systems.
 4. Sleeve-seal fittings.
 5. Grout.

1.3 ACTION SUBMITTALS

- A. Product Data: For each type of product indicated.

PART 2 - PRODUCTS

2.1 SLEEVES

- A. Cast-Iron Wall Pipes: Cast or fabricated of cast or ductile iron and equivalent to ductile-iron pressure pipe, with plain ends and integral waterstop unless otherwise indicated.
- B. Galvanized-Steel Wall Pipes: ASTM A 53, Schedule 40, with plain ends and welded steel collar; zinc coated.
- C. Galvanized-Steel-Pipe Sleeves: ASTM A 53, Type E, Grade B, Schedule 40, zinc coated, with plain ends.
- D. PVC-Pipe Sleeves: ASTM D 1785, Schedule 40.
- E. Galvanized-Steel-Sheet Sleeves: 0.0239-inch minimum thickness; round tube closed with welded longitudinal joint.
- F. Molded-PE or -PP Sleeves: Removable, tapered-cup shaped, and smooth outer surface with nailing flange for attaching to wooden forms.
- G. Molded-PVC Sleeves: With nailing flange for attaching to wooden forms.

2.2 STACK-SLEEVE FITTINGS

- A. Manufacturers: Subject to compliance with requirements, provide products by one of the following:

- B. Manufacturers: Subject to compliance with requirements, provide products by one of the following:
 - 1. Smith, Jay R. Mfg. Co.
 - 2. Zurn Industries, LLC.
- C. Description: Manufactured, cast-iron sleeve with integral clamping flange. Include clamping ring, bolts, and nuts for membrane flashing.
 - 1. Underdeck Clamp: Clamping ring with setscrews.

2.3 SLEEVE-SEAL SYSTEMS

- A. Manufacturers: Subject to compliance with requirements, provide products by one of the following:
 - 1. Advance Products & Systems, Inc.
 - 2. CALPICO, Inc.
 - 3. Metraflex Company (The).
 - 4. Pipeline Seal and Insulator, Inc.
 - 5. Proco Products, Inc.
 - 6. Hilti, cast in place system
- B. Description: Modular sealing-element unit, designed for field assembly, for filling annular space between piping and sleeve.
 - 1. Sealing Elements: EPDM-rubber interlocking links shaped to fit surface of pipe. Include type and number required for pipe material and size of pipe.
 - 2. Pressure Plates: Stainless steel.
 - 3. Connecting Bolts and Nuts: Stainless steel of length required to secure pressure plates to sealing elements.

2.4 SLEEVE-SEAL FITTINGS

- A. Manufacturers: Subject to compliance with requirements, provide products by one of the following:
- B. Manufacturers: Subject to compliance with requirements, provide products by one of the following:
 - 1. HOLDRITE.
- C. Description: Manufactured plastic, sleeve-type, waterstop assembly made for imbedding in concrete slab or wall. Unit has plastic or rubber waterstop collar with center opening to match piping OD.

2.5 GROUT

- A. Standard: ASTM C 1107/C 1107M, Grade B, post-hardening and volume-adjusting, dry, hydraulic-cement grout.
- B. Characteristics: Nonshrink; recommended for interior and exterior applications.
- C. Design Mix: 5000-psi, 28-day compressive strength.
- D. Packaging: Premixed and factory packaged.

PART 3 - EXECUTION

3.1 SLEEVE INSTALLATION

- A. Install sleeves for piping passing through penetrations in floors, partitions, roofs, and walls.
- B. For sleeves that will have sleeve-seal system installed, select sleeves of size large enough to provide Insert dimension annular clear space between piping and concrete slabs and walls.
 - 1. Sleeves are not required for core-drilled holes.
- C. Install sleeves in concrete floors, concrete roof slabs, and concrete walls as new slabs and walls are constructed.
 - 1. Permanent sleeves are not required for holes in slabs formed by molded-PE or -PP sleeves.
 - 2. Cut sleeves to length for mounting flush with both surfaces.
 - a. Exception: Extend sleeves installed in floors of mechanical equipment areas or other wet areas 2 inches above finished floor level.
 - 3. Using grout, seal the space outside of sleeves in slabs and walls without sleeve-seal system.
- D. Install sleeves for pipes passing through interior partitions.
 - 1. Cut sleeves to length for mounting flush with both surfaces.
 - 2. Install sleeves that are large enough to provide 1/4-inch annular clear space between sleeve and pipe or pipe insulation.
 - 3. Seal annular space between sleeve and piping or piping insulation; use joint sealants appropriate for size, depth, and location of joint. Comply with requirements for sealants specified in Division 07 Section "Joint Sealants."
 - 4. For sound-rated partitions, fill the opening between sleeve and piping with insulation prior to sealing.
- E. Fire-Barrier Penetrations: Maintain indicated fire rating of walls, partitions, ceilings, and floors at pipe penetrations. Seal pipe penetrations with firestop materials. Comply with requirements for firestopping specified in Division 07 Section "Penetration Firestopping."

3.2 STACK-SLEEVE-FITTING INSTALLATION

- A. Install stack-sleeve fittings in new slabs as slabs are constructed.
 - 1. Install fittings that are large enough to provide 1/4-inch annular clear space between sleeve and pipe or pipe insulation.
 - 2. Secure flashing between clamping flanges for pipes penetrating floors with membrane waterproofing. Comply with requirements for flashing specified in Division 07 Section "Sheet Metal Flashing and Trim."
 - 3. Install section of cast-iron soil pipe to extend sleeve to 2 inches above finished floor level.
 - 4. Extend cast-iron sleeve fittings below floor slab as required to secure clamping ring if ring is specified.
 - 5. Using grout, seal the space around outside of stack-sleeve fittings.
- B. Fire-Barrier Penetrations: Maintain indicated fire rating of floors at pipe penetrations. Seal pipe penetrations with firestop materials. Comply with requirements for firestopping specified in Division 07 Section "Penetration Firestopping."

3.3 SLEEVE-SEAL-SYSTEM INSTALLATION

- A. Install sleeve-seal systems in sleeves in exterior concrete walls and slabs-on-grade at service piping entries into building.

- B. Select type, size, and number of sealing elements required for piping material and size and for sleeve ID or hole size. Position piping in center of sleeve. Center piping in penetration, assemble sleeve-seal system components, and install in annular space between piping and sleeve. Tighten bolts against pressure plates that cause sealing elements to expand and make a watertight seal.

3.4 SLEEVE-SEAL-FITTING INSTALLATION

- A. Install sleeve-seal fittings in new walls and slabs as they are constructed.
- B. Assemble fitting components of length to be flush with both surfaces of concrete slabs and walls. Position waterstop flange to be centered in concrete slab or wall.
- C. Secure nailing flanges to concrete forms.
- D. Using grout, seal the space around outside of sleeve-seal fittings.

3.5 SLEEVE AND SLEEVE-SEAL SCHEDULE

- A. Use sleeves and sleeve seals for the following piping-penetration applications:
 - 1. Exterior Concrete Walls above Grade:
 - a. Piping Smaller Than NPS 6: Cast-iron wall sleeves.
 - b. Piping NPS 6 and Larger: Cast-iron wall sleeves.
 - 2. Exterior Concrete Walls below Grade:
 - a. Piping Smaller Than NPS 6: Cast-iron wall sleeves with sleeve-seal system.
 - 1) Select sleeve size to allow for 1-inch annular clear space between piping and sleeve for installing sleeve-seal system.
 - b. Piping NPS 6 and Larger: Cast-iron wall sleeves with sleeve-seal system.
 - 1) Select sleeve size to allow for 1-inch annular clear space between piping and sleeve for installing sleeve-seal system.
 - 3. Concrete Slabs-on-Grade:
 - a. Piping Smaller Than NPS 6: Cast-iron wall sleeves with sleeve-seal system.
 - 1) Select sleeve size to allow for 1-inch annular clear space between piping and sleeve for installing sleeve-seal system.
 - b. Piping NPS 6 and Larger: Cast-iron wall sleeves with sleeve-seal system.
 - 1) Select sleeve size to allow for 1-inch annular clear space between piping and sleeve for installing sleeve-seal system.
 - 4. Concrete Slabs above Grade:
 - a. Piping Smaller Than NPS 6: Galvanized-steel-pipe sleeves.
 - b. Piping NPS 6 and Larger: Galvanized-steel-pipe sleeves.

5. Interior Partitions:
 - a. Piping Smaller Than NPS 6: Galvanized-steel-pipe sleeves.
 - b. Piping NPS 6 and Larger: Galvanized-steel-sheet sleeves.

END OF SECTION 23 0517

THIS PAGE LEFT BLANK INTENTIONALLY

SECTION 23 0518

ESCUTCHEONS FOR HVAC PIPING

PART 1 - GENERAL

1.1 RELATED DOCUMENTS

- A. Drawings and general provisions of the Contract, including General and Supplementary Conditions and Division 01 Specification Sections, apply to this Section.

1.2 SUMMARY

- A. Section Includes:
 - 1. Escutcheons.

1.3 ACTION SUBMITTALS

- A. Product Data: For each type of product indicated.

PART 2 - PRODUCTS

2.1 ESCUTCHEONS

- A. One-Piece, Cast-Brass Type: With polished, chrome-plated or rough-brass finish and setscrew fastener.
- B. One-Piece, Deep-Pattern Type: Deep-drawn, box-shaped brass with chrome-plated finish and spring-clip fasteners.
- C. One-Piece, Stamped-Steel Type: With chrome-plated finish and spring-clip fasteners.

PART 3 - EXECUTION

3.1 INSTALLATION

- A. Install escutcheons for piping penetrations of walls, ceilings, and finished floors.
- B. Install escutcheons with ID to closely fit around pipe, tube, and insulation of insulated piping and with OD that completely covers opening.
 - 1. Escutcheons for New Piping:
 - a. Piping with Fitting or Sleeve Protruding from Wall: One-piece, deep-pattern type with polished, chrome-plated finish.
 - b. Chrome-Plated Piping: One-piece, cast-brass type with polished, chrome-plated finish.
 - c. Insulated Piping: One-piece, stamped-steel type with chrome-plated finish.

- d. Bare Piping 2 inch and Smaller at Wall and Floor Penetrations in Finished Spaces: One-piece, cast-brass type with polished, chrome-plated finish.
- e. Bare Piping Larger than 2 inch at Wall and Floor Penetrations in Finished Spaces: One-piece, stamped-steel type with polished, chrome-plated finish.
- f. Bare Piping 2 inch and Smaller at Ceiling Penetrations in Finished Spaces: One-piece, cast-brass type with polished, chrome-plated finish.
- g. Bare Piping Larger than 2 inch at Ceiling Penetrations in Finished Spaces: One-piece, stamped-steel type with polished, chrome-plated finish.
- h. Bare Piping 2 inch and Smaller in Unfinished Service Spaces: One-piece, cast-brass type with polished, chrome-plated.
- i. Bare Piping Larger than 2 inch in Unfinished Service Spaces: One-piece, stamped-steel type with polished, chrome-plated finish.
- j. Bare Piping 2 inch and Smaller in Equipment Rooms: One-piece, cast-brass type with polished, chrome-plated finish.
- k. Bare Piping in Equipment Rooms Larger than 2 inch: One-piece, stamped-steel type with chrome- or cadmium-plated finish.

3.2 FIELD QUALITY CONTROL

- A. Replace broken and damaged escutcheons and floor plates using new materials.

END OF SECTION 23 0518

SECTION 23 0519

METERS AND GAGES FOR HVAC

PART 1 - GENERAL

1.1 RELATED DOCUMENTS

- A. Drawings and general provisions of the Contract, including General and Supplementary Conditions and Division 01 Specification Sections, apply to this Section.

1.2 SUMMARY

- A. Section Includes:
 1. Liquid-in-glass thermometers.
 2. Thermowells.
 3. Pressure gages.
 4. Gage attachments.
 5. Test plugs.
 6. Test-plug kits.
 7. Flowmeters.
- B. Related Sections:
 1. Division 23 Section "Facility Natural-Gas Piping" for gas meters.
 2. Division 23 Section "Steam and Condensate Heating Piping" for steam and condensate meters.

1.3 ACTION SUBMITTALS

- A. Product Data: For each type of product indicated.
- B. Wiring Diagrams: For power, signal, and control wiring.

1.4 INFORMATIONAL SUBMITTALS

- A. Product Certificates: For each type of meter and gage, from manufacturer.

1.5 CLOSEOUT SUBMITTALS

- A. Operation and Maintenance Data: For meters and gages to include in operation and maintenance manuals.

PART 2 - PRODUCTS

2.1 LIQUID-IN-GLASS THERMOMETERS

- A. Metal-Case, Industrial-Style, Liquid-in-Glass Thermometers:

1. Manufacturers: Subject to compliance with requirements, provide products by one of the following:
 - a. Palmer Wahl Instrumentation Group.
 - b. Terice, H. O. Co.
 - c. Weiss Instruments, Inc.
 - d. Weksler.
2. Standard: ASME B40.200.
3. Case: Die Cast aluminum or brass; nominal size unless otherwise indicated.
4. Case Form: Adjustable angle type unless otherwise indicated, 180 degrees in vertical plane, 360 degrees in horizontal plane, with locking device.
5. Tube: Glass with magnifying lens and blue organic liquid.
6. Tube Background: Satin faced, nonreflective aluminum with permanently etched scale markings graduated in deg F.
7. Window: Glass.
8. Stem: Copper-plated steel, aluminum, stainless steel, or brass designed for thermowell installation. Stem shall be of length to match thermowell insertion length.
 - a. Design for Thermowell Installation: Bare stem.
9. Connector: 1-1/4 inches, with ASME B1.1 screw threads.
10. Accuracy: Plus or minus 1 percent of scale range or one scale division, to a maximum of 1.5 percent of scale range.

2.2 THERMOWELLS

A. Thermowells:

1. Manufacturers: Subject to compliance with requirements, provide products by one of the following:
 - a. AMETEK, Inc.; U.S. Gauge Div.
 - b. Ashcroft Commercial Instrument Operations; Dresser Industries; Instrument Div.
 - c. Ernst Gage Co.
 - d. Marsh Bellofram.
 - e. Miljoco Corp.
 - f. NANMAC Corporation.
 - g. Noshok, Inc.
 - h. Palmer - Wahl Instruments Inc.
 - i. REO TEMP Instrument Corporation.
 - j. Tel-Tru Manufacturing Company.
 - k. Terice, H. O. Co.
 - l. Weiss Instruments, Inc.
 - m. Weksler
 - n. WIKA Instrument Corporation.
 - o. Winters Instruments.
2. Manufacturers: Same as manufacturer of thermometer being used.
3. Standard: ASME B40.200.
4. Description: Pressure-tight, socket-type fitting made for insertion into piping tee fitting.
5. Material for Use with Copper Tubing: Brass.
6. Material for Use with Steel Piping: Brass.
7. Type: Stepped shank unless straight or tapered shank is indicated.
8. External Threads: NPS 1/2, NPS 3/4, NPS 1 or NPS 1-1/4 ASME B1.20.1 pipe threads.
9. Internal Threads: 1/2, 3/4, and 1 inch with ASME B1.1 screw threads.
10. Bore: Diameter required to match thermometer bulb or stem.
11. Insertion Length: Length required to match thermometer bulb or stem.
12. Lagging Extension: Include on thermowells for insulated piping and tubing.

13. Bushings: For converting size of thermowell's internal screw thread to size of thermometer connection.

B. Heat-Transfer Medium: Mixture of graphite and glycerin.

2.3 PRESSURE GAGES

A. Direct-Mounted, Metal-Case, Dial-Type Pressure Gages:

1. Manufacturers: Subject to compliance with requirements, provide products by one of the following:
 - a. AMETEK, Inc.; U.S. Gauge.
 - b. Ashcroft Inc.
 - c. Ernst Flow Industries.
 - d. KOBOLD Instruments, Inc.
 - e. Marsh Bellofram.
 - f. Miljoco Corporation.
 - g. Noshok.
 - h. Palmer Wahl Instrumentation Group.
 - i. REOTEMP Instrument Corporation.
 - j. Terice, H. O. Co.
 - k. Weiss Instruments, Inc.
 - l. Weksler
 - m. WIKA Instrument Corporation.
 - n. Winters Instruments - U.S.
2. Standard: ASME B40.100.
3. Case: Liquid-filled type; cast aluminum or drawn steel; 4-1/2-inch nominal diameter.
4. Pressure-Element Assembly: Bourdon tube unless otherwise indicated.
5. Pressure Connection: Brass, with ASME B1.20.1 pipe threads and bottom-outlet type unless back-outlet type is indicated. NPS 1/4 or NPS 1/2.
6. Movement: Mechanical, with link to pressure element and connection to pointer.
7. Dial: Satin faced, nonreflective aluminum with permanently etched scale markings graduated in psi .
8. Pointer: Dark-colored metal.
9. Window: Glass.
10. Ring: Stainless steel.
11. Accuracy: Grade A, plus or minus 1 percent of middle half of scale range.

B. Remote-Mounted, Metal-Case, Dial-Type Pressure Gages:

1. Manufacturers: Subject to compliance with requirements, provide products by one of the following:
 - a. AMETEK, Inc.; U.S. Gauge.
 - b. Ashcroft Inc.
 - c. Ernst Flow Industries.
 - d. KOBOLD Instruments, Inc.
 - e. Marsh Bellofram.
 - f. Miljoco Corporation.
 - g. Noshok.
 - h. Palmer Wahl Instrumentation Group.
 - i. REOTEMP Instrument Corporation.
 - j. Terice, H. O. Co.
 - k. Weiss Instruments, Inc.
 - l. Weksler
 - m. WIKA Instrument Corporation.
 - n. Winters Instruments - U.S.

2. Standard: ASME B40.100.
3. Case: Liquid-filled, cast aluminum or drawn steel; diameter with back flange for panel surface mounting or front flange for panel recessed mounting. Flanges to include pre-drilled screw holes.
4. Pressure-Element Assembly: Bourdon tube unless otherwise indicated.
5. Pressure Connection: Brass, with ASME B1.20.1 pipe threads and bottom-outlet type unless back-outlet type is indicated. NPS 1/4 or NPS 1/2.
6. Movement: Mechanical, with link to pressure element and connection to pointer.
7. Dial: Satin faced, nonreflective aluminum with permanently etched scale markings graduated in psi .
8. Pointer: Dark-colored metal.
9. Window: Glass.
10. Ring: Stainless steel.
11. Accuracy: Grade A, plus or minus 1 percent of middle half of scale range.

2.4 GAGE ATTACHMENTS

- A. Snubbers: ASME B40.100, brass; with ASME B1.20.1 pipe threads. Include extension for use on insulated piping. NPS 1/4 or NPS 1/2 .
 1. Surge-dampening device: porous-metal-type.
- B. Siphons:
 1. Loop-shaped section: Brass pipe with pipe threads. NPS 1/4 or NPS 1/2.
- C. Valves:
 1. Needle: Brass, with NPS 1/4 or NPS 1/2 ASME B1.20.1 pipe threads.

2.5 TEST PLUGS

- A. Manufacturers: Subject to compliance with requirements, provide products by one of the following:
 1. Flow Design, Inc.
 2. MG Piping Products Co.
 3. National Meter, Inc.
 4. Peterson Equipment Co., Inc.
 5. Sisco Manufacturing Company, Inc.
 6. Trerice, H. O. Co.
 7. Twin City Hose.
 8. Watts Regulator Co.; a div. of Watts Water Technologies, Inc.
 9. Welsler.
- B. Description: Test-station fitting made for insertion into piping tee fitting.
- C. Body: Brass or stainless steel with core inserts and gasketed and threaded cap. Include extended stem on units to be installed in insulated piping.
- D. Thread Size: or , ASME B1.20.1 pipe thread.
- E. Minimum Pressure and Temperature Rating:
- F. Core Inserts: Self-sealing synthetic rubber;
 1. EPDM (Nordel) for air, water or glycol operation between 30 and 275 deg F.
 2. CR (Neoprene) for air, water, glycol, oil, or gas operation between -30 to 200 deg F.

2.6 TEST-PLUG KITS

- A. Manufacturers: Subject to compliance with requirements, provide products by one of the following:
1. Flow Design, Inc.
 2. MG Piping Products Co.
 3. National Meter, Inc.
 4. Peterson Equipment Co., Inc.
 5. Sisco Manufacturing Company, Inc.
 6. Trerice, H. O. Co.
 7. Watts Regulator Co.; a div. of Watts Water Technologies, Inc.
 8. Weiss Instruments, Inc.
- B. Furnish the number of test-plug kits given below with the number of thermometers given below, with each kit having one pressure gage and adapter, and carrying case. Thermometer sensing elements, pressure gage, and adapter probes shall be of diameter to fit test plugs and of length to project into piping.
1. Low-Range Thermometer: Small, bimetallic insertion type with 2-inch diameter dial and tapered-end sensing element. Dial range shall be at least 25 to 125 deg F .
 2. High-Range Thermometer: Small, bimetallic insertion type with 2-inch diameter dial and tapered-end sensing element. Dial range shall be at least 0 to 220 deg F .
 3. Pressure Gage: Small, Bourdon-tube insertion type with 3-inch diameter dial and probe. Dial range shall be at least to 200 psig.
 4. Carrying Case: Metal or plastic, with formed instrument padding.
 5. One test-plug kit with:
 - a. Two thermometers.

2.7 FLOWMETERS

- A. Orifice Flowmeters:
1. Manufacturers: Subject to compliance with requirements, provide products by one of the following:
 - a. ABB; Instrumentation and Analytical.
 - b. Armstrong Pumps Inc.; S. A. Armstrong Limited.
 - c. Badger Meter, Inc.; Industrial Div.
 - d. Bell & Gossett; ITT Industries.
 - e. Meriam Process Technologies.
 2. Description: Flowmeter with sensor, hoses or tubing, quick connect hose fittings, valves, indicator, and conversion chart.
 3. Flow Range: Sensor and indicator shall cover operating range of equipment or system served.
 4. Sensor: Wafer-orifice-type, calibrated, flow-measuring element; for installation between pipe flanges.
 - a. Design: Differential-pressure-type measurement:
 - 1) For HVAC hot and chilled water.
 - b. Construction: Cast-iron body, brass valves with integral check valves and caps, and calibrated nameplate.
 - c. Minimum Pressure Rating: 300 psig.
 - d. Minimum Temperature Rating: 250 deg F .
 5. Portable Indicators: Hand-held, differential-pressure type, calibrated for connected sensor and having two 12-foot hoses, with carrying case.

- a. Scale: Gallons per minute.
- b. Accuracy: Plus or minus 2 percent between 20 and 80 percent of scale range.
- 6. Conversion Chart: Flow rate data compatible with sensor and indicator.
- 7. Operating Instructions: Include complete instructions with each flowmeter.

B. Venturi Flowmeters:

- 1. Manufacturers: Subject to compliance with requirements, provide products by one of the following:
 - a. Armstrong Pump
 - b. Badger Meter, Inc.; Industrial Division
 - c. Bailey-Fischer & Porter Co.
 - d. Flow Design, Inc.
 - e. Gerand Engineering Co.
 - f. Hyspan Precision Products, Inc.
 - g. Leeds & Northrup.
 - h. McCrometer, Inc.
 - i. Preso Meters; a division of Racine Federated Inc.
 - j. Victaulic Company.
- 2. Description: Flowmeter with calibrated flow-measuring element, hoses or tubing, quick connect hose fittings, valves, indicator, and conversion chart.
- 3. Flow Range: Sensor and indicator shall cover operating range of equipment or system served.
- 4. Sensor: Venturi-type, calibrated, flow-measuring element; for installation in piping.
 - a. Design: Differential-pressure-type measurement for water.
 - b. Construction: Bronze, brass, or factory-primed steel, with brass fittings and attached tag with flow conversion data.
 - c. Minimum Pressure Rating: 250 psig.
 - d. Minimum Temperature Rating: 250 deg F.
 - e. End Connections for NPS 2 and Smaller: Threaded.
 - f. End Connections for NPS 2-1/2 and Larger: Flanged or welded.
 - g. Flow Range: Flow-measuring element and flowmeter shall cover operating range of equipment or system served.

C. Vortex-Shedding Flowmeters: (Steam Service)

- 1. Manufacturers: Subject to compliance with requirements, provide products by one of the following:
 - a. ABB; Instrumentation and Analytical.
 - b. Eastech Flow Controls.
 - c. EMCO Flow Systems; a division of Spirax Sarco, Inc.
 - d. Emerson Process Management; Rosemount.
 - e. Endress+Hauser.
 - f. ISTECH Corporation.
 - g. ONICON Incorporated
- 2. Description: Flowmeter with sensor and indicator.
- 3. Flow Range: Sensor and indicator shall cover operating range of equipment or system served.
- 4. Sensor: Inline type; for installing between pipe flanges and measuring flow directly in .
 - a. Design: Flow obstruction device, vortex-measurement type for steam.
 - b. Construction: Stainless-steel body, with integral transmitter and direct-reading scale.
 - c. Minimum Pressure Rating: 100 psig.
 - d. Minimum Temperature Rating: 400° F.

- e. Integral Transformer: For low-voltage power operation.
- 5. Indicator: Hand-held meter; either an integral part of sensor or a separate meter.
- 6. Accuracy: Plus or minus 0.25 percent for liquids and 0.75 percent for gases.
- 7. Display: Shows rate of flow, with register to indicate total volume in lbs/hr.
- 8. Operating Instructions: Include complete instructions with each flowmeter.

D. Turbine Flowmeters:

- 1. Manufacturers: Subject to compliance with requirements, provide products by one of the following:
 - a. ABB; Instrumentation and Analytical.
 - b. Data Industrial Corp.
 - c. EMCO Flow Systems; a division of Spirax Sarco, Inc.
 - d. ERDCO Engineering Corp.
 - e. Hoffer Flow Controls, Inc.
 - f. Liquid Controls; a unit of IDEX Corporation.
 - g. McCrometer, Inc.
 - h. Midwest Instruments & Controls Corp.
 - i. ONICON Incorporated.
 - j. SeaMetrics, Inc.
 - k. Sponsler, Inc.; a unit of IDEX Corporation.
- 2. Description: Flowmeter with sensor and indicator.
- 3. Flow Range: Sensor and indicator shall cover operating range of equipment or system served.
- 4. Sensor: Impeller turbine; for inserting into pipe fitting or for installing in piping and measuring flow directly in gallons per minute.
 - a. Design: Device or pipe fitting with inline turbine and integral direct-reading scale for water.
 - b. Construction: Bronze or stainless-steel body, with plastic turbine or impeller.
 - c. Minimum Pressure Rating: 150 psig.
 - d. Minimum Temperature Rating: 180 deg F.
- 5. Indicator: Hand-held meter; either an integral part of sensor or a separate meter.
- 6. Accuracy: Plus or minus 1-1/2 percent.
- 7. Display: Shows rate of flow, with register to indicate total volume in gallons.
- 8. Operating Instructions: Include complete instructions with each flowmeter.

2.8 THERMAL-MASS FLOW METERS (Natural Gas Service)

A. Thermal-Mass Flow Meters:

- 1. Manufacturers: Subject to compliance with requirements, provide products by one of the following:
 - a. Data Industrial Corp.
 - b. Hoffer Flow Controls, Inc.
 - c. ISTECH Corporation.
 - d. ONICON Incorporated.
 - e. Nexus.
- 2. Description: System with flow sensor, transmitter, indicator, and connecting wiring.
- 3. Flow Sensor: Corrosion-resistant-metal body and transmitter; for installing in piping.
 - a. Design: Total flow measurement.
 - b. Operating Pressure Rating: 250 PSI Maximum

- c. Ambient Temperature Range: 0°F to 150° F
 - d. Fluid Temperature Range: -40°F to 150°F
4. Temperature Sensors: Insertion-type transducer.
 5. Indicator: Solid-state, integrating-type meter with pulse meter display with network connections for BACnet BMS system; for wall mounting.
 6. Accuracy: Plus or minus 2 percent.
 7. Display: Visually indicates total fluid volume in Cubic Feet/Hr.
 8. Operating Instructions: Include complete instructions with each meter system.

2.9 ELECTROMAGNETIC FLOW METERS (Water Service)

A. Electromagnetic Flow Meters:

1. Manufacturers: Subject to compliance with requirements, provide products by one of the following:
 - a. Data Industrial Corp.
 - b. Hoffer Flow Controls, Inc.
 - c. ISTECH Corporation.
 - d. ONICON Incorporated.
 - e. Nexus.
2. Description: System with electromagnetic sensing flow sensor, transmitter, indicator, and connecting wiring.
3. Flow Sensor: Corrosion-resistant-metal body and transmitter; for installing in piping.
 - a. Design: Total flow measurement.
 - b. Operating Pressure Rating: 400 PSI Maximum
 - c. Ambient Temperature Range: -20° F to 150° F
 - d. Fluid Temperature Range: 15° F to 250° F
4. Temperature Sensors: Insertion-type transducer.
5. Indicator: Solid-state, integrating-type meter with analog meter display with network connections for BACnet BMS system; for wall mounting.
6. Accuracy: Plus or minus 2 percent.
7. Display: Visually indicates total fluid volume in Cubic Feet/Hr.
8. Operating Instructions: Include complete instructions with each meter system.

PART 3 - EXECUTION

3.1 INSTALLATION

- A. Install thermowells: with socket extending one-third of pipe diameter and in vertical position in piping tees.
- B. Install thermowells of sizes required to match thermometer connectors. Include bushings if required to match sizes.
- C. Install thermowells with extension on insulated piping.
- D. Fill thermowells with heat-transfer medium.
- E. Install direct-mounted thermometers in thermowells and adjust vertical and tilted positions to most readable position.

- F. Install direct-mounted pressure gages in piping tees with pressure gage located on pipe at the most readable position.
- G. Install needle-valve and snubber in piping for each pressure gage for fluids. Exception: Steam.
- H. Install test plugs in piping tees.
- I. Install flow indicators in piping systems in accessible positions for easy viewing.
- J. Assemble and install connections, tubing, and accessories between flow-measuring elements and flowmeters according to manufacturer's written instructions.
- K. Install flowmeter elements in accessible positions in piping systems.
- L. Install wafer-orifice flowmeter elements between pipe flanges.
- M. Install differential-pressure-type flowmeter elements, with at least minimum straight lengths of pipe, upstream and downstream from element according to manufacturer's written instructions.
- N. Install permanent indicators on walls or brackets in accessible and readable positions.
- O. Install connection fittings in accessible locations for attachment to portable indicators.
- P. Mount meters on wall if accessible; if not, provide brackets to support meters.
- Q. Install thermometers in the following locations:
 - 1. Inlet and outlet of each hydronic boiler.
 - 2. Two inlets and two outlets of each chiller.
 - 3. Inlet and outlet of each hydronic coil in air-handling units.
 - 4. Two inlets and two outlets of each hydronic heat exchanger.
 - 5. Inlet and outlet of each thermal-storage tank.
 - 6. Inlet and outlet of each piece of steam equipment.
- R. Install pressure gages in the following locations:
 - 1. Inlet and discharge of each pressure-reducing valve.
 - 2. Inlet and outlet of each chiller chilled-water and condenser-water connection.
 - 3. Suction and discharge of each pump.

3.2 CONNECTIONS

- A. Install meters and gages adjacent to machines and equipment to allow service and maintenance of meters, gages, machines, and equipment.

3.3 ADJUSTING

- A. Adjust faces of meters and gages to proper angle for best visibility.

3.4 THERMOMETER SCHEDULE

- A. Thermometers at inlet and outlet of each hydronic zone shall be the following:
 - 1. Test plug: With EPDM self-sealing rubber inserts.
- B. Thermometers at inlet and outlet of each hydronic boiler shall be the following:

1. Industrial-style, liquid-in-glass type.
- C. Thermometers at inlets and outlets of each chiller shall be the following:
1. Industrial-style, liquid-in-glass type.
- D. Thermometers at inlet and outlet of each hydronic coil in air-handling units and built-up central systems shall be the following:
1. Industrial-style, liquid-in-glass type.
- E. Thermometers at inlet and outlet of each hydronic coil at fan coils, cabinet heaters, unit heaters and reheat coils and as shown on details shall be the following:
1. Industrial-style, liquid-in-glass type.
 2. Test plug with EPDM self-sealing rubber inserts.
- F. Thermometers at inlets and outlets of each hydronic heat exchanger shall be the following:
1. Industrial-style, liquid-in-glass type.
- G. Thermometers at inlet and outlet of each hydronic heat-recovery unit shall be the following:
1. Industrial-style, liquid-in-glass type.
- H. Thermometers at inlet and outlet of each thermal-storage tank shall be the following:
1. Industrial-style, liquid-in-glass type.
- I. Thermometer stems shall be of length to match thermowell insertion length.

3.5 THERMOMETER SCALE-RANGE SCHEDULE

- A. Scale Range for Chilled-Water Piping: 0 to 100 deg F.
- B. Scale Range for Condenser-Water Piping: 0 to 150 deg F.
- C. Scale Range for Heating, Hot-Water Piping: 30 to 240 deg F.
- D. Scale Range for Steam and Steam-Condensate Piping: 30 to 240 deg F.
- E. Scale Range for Air Ducts: Minus 40 to plus 110 deg F.

3.6 PRESSURE-GAGE SCHEDULE

- A. Pressure gages at inlet and discharge of each pressure-reducing valve shall be the following:
 1. Dry-case type, direct-mounted, metal case.
- B. Pressure gages at inlet and outlet of each chiller chilled-water and condenser-water connection shall be the following:
 1. Liquid-filled, direct-mounted, metal case.
- C. Pressure gages at suction and discharge of each pump shall be the following:
 1. Liquid-filled, direct-mounted, metal case.

3.7 PRESSURE-GAGE SCALE-RANGE SCHEDULE

- A. Scale Range for Chilled-Water, Condenser-Water, Heating, Hot-Water, Steam and Condensate Piping shall be twice the normal operating pressure of the measured system with gage ranges as follows:
1. 30 in. Hg to 15 psi.
 2. 0 to 30 psi.
 3. 0 to 100 psi.
 4. 0 to 160 psi.
 5. 0 to 200 psi.
 6. 0 to 300 psi.
 7. 0 to 600 psi.

3.8 FLOWMETER SCHEDULE. See flow meter schedule on drawings for flowmeter type.

END OF SECTION 23 0519

THIS PAGE LEFT BLANK INTENTIONALLY

SECTION 23 0523

GENERAL-DUTY VALVES FOR HVAC PIPING

PART 1 - GENERAL

1.1 RELATED DOCUMENTS

- A. Drawings and general provisions of the Contract, including General and Supplementary Conditions and Division 01 Specification Sections, apply to this Section.

1.2 SUMMARY

- A. Section Includes:

1. Bronze ball valves.
2. Iron, single-flange butterfly valves.
3. Bronze lift check valves.
4. Bronze swing check valves.
5. Iron swing check valves.
8. Bronze globe valves.
9. Iron globe valves.
10. Lubricated plug valves.
11. Chainwheels.
12. High-performance butterfly valves.

- B. Related Sections:

1. Division 23 Section "Identification for HVAC Piping and Equipment" for valve tags and schedules.

1.3 DEFINITIONS

- A. CWP: Cold working pressure.
- B. EPDM: Ethylene propylene copolymer rubber.
- C. NBR: Acrylonitrile-butadiene, Buna-N, or nitrile rubber.
- D. NRS: Nonrising stem.
- E. OS&Y: Outside screw and yoke.
- F. RS: Rising stem.
- G. SWP: Steam working pressure.

1.4 ACTION SUBMITTALS

- A. Product Data: For each type of valve indicated. Body material, valve design, pressure and temperature classification, end connection details, seating materials, trim material and

arrangement, dimensions and required clearances, and installation instructions. Include list indicating valve and its application.

- B. Maintenance data for valves to be included in the operation and maintenance data specified in Division 1. Include detailed manufacturer's instructions on adjusting, servicing, disassembling, and repairing.

1.5 QUALITY ASSURANCE

- A. Source Limitations for Valves: Obtain each type of valve as listed in SUMMARY from a single source and from a single manufacturer.
- B. Compliance:
 - 1. ASME B16.10 and ASME B16.34 for ferrous valve dimensions and design criteria.
 - 2. ASME B31.1 for power piping valves.
 - 3. ASME B31.9 for building services piping valves.
 - 4. MSS Compliance: Comply with the various MSS Standard Practice documents referenced.

1.6 DELIVERY, STORAGE, AND HANDLING

- A. Prepare valves for shipping as follows:
 - 1. Protect internal parts against rust and corrosion.
 - 2. Protect threads, flange faces, and weld ends.
 - 3. Set angle, and globe valves closed to prevent rattling.
 - 4. Set ball and plug valves open to minimize exposure of functional surfaces.
 - 5. Set butterfly valves closed or slightly open.
 - 6. Block check valves in either closed or open position.
- B. Use the following precautions during storage:
 - 1. Maintain valve end protection.
 - 2. Store valves indoors and maintain at higher than ambient dew point temperature. If outdoor storage is necessary, store valves off the ground in watertight enclosures.
- C. Use sling to handle large valves; rig sling to avoid damage to exposed parts. Do not use handwheels or stems as lifting or rigging points.

PART 2 - PRODUCTS

2.1 GENERAL REQUIREMENTS FOR VALVES

- A. Refer to HVAC valve schedule articles for applications of valves.
- B. Valve Pressure and Temperature Ratings: Not less than indicated and as required for system pressures and temperatures.
- C. Valve Sizes: Same as upstream piping unless otherwise indicated.
- D. Valve Actuator Types:
 - 1. Gear Actuator: For quarter-turn valves NPS 8 and larger.

2. Handwheel: For valves other than quarter-turn types.
 3. Handlever: For quarter-turn valves NPS 6 and smaller[except plug valves].
 4. Wrench: For plug valves with square heads. Furnish Owner with 1 wrench for every 10 plug valves, for each size square plug-valve head.
 5. Chainwheel: Device for attachment to valve handwheel, stem, or other actuator; of size and with chain for mounting height, as indicated in the "Valve Installation" Article.
- E. Valves in Insulated Piping: With 2-inch stem extensions and the following features:
2. Ball Valves: With extended operating handle of non-thermal-conductive material, and protective sleeve that allows operation of valve without breaking the vapor seal or disturbing insulation.
 3. Butterfly Valves: With extended neck.
- F. Valve-End Connections:
1. Flanged: With flanges according to ASME B16.1 for iron valves.
 2. Solder Joint: With sockets according to ASME B16.18.
 - a. Caution: Where soldered end connections are used, use solder having a melting point below 840 deg. For, globe, and check valves: below 421 deg. F for ball valves.
 3. Threaded: With threads according to ASME B1.20.1.
- G. Valve Bypass and Drain Connections: MSS SP-45.

2.2 MANUFACTURERS

- A. Subject to compliance with requirements, provide products by one of the following:
1. APCO Willamette Valve and Primer Corp.
 2. Babbitt Steam Specialty Company.
 3. Bray Controls.
 4. Center Line.
 5. Cla-Val Company.
 6. Conbraco Industries Inc.
 7. Crane Co.; Crane Valve Group.
 8. Fisher Valve by Emerson.
 9. Flo Fab Inc.
 10. Flow-Tek Inc.
 11. Grinnell Corporation.
 12. Hammond Valve.
 13. Jamesbury; a subsidiary of Metso Automation.
 14. Jomar International LTD.
 15. Keystone Valve USA, Inc.
 16. Kitz Corp.
 17. Metraflex Company.
 18. Milwaukee Valve Company.
 19. Mueller Steam Specialty.
 20. NIBCO Inc.
 21. Red-White Valve Corp.
 22. Spence Strainers International.
 23. Stockham Valves and Fittings, Inc.
 24. Tyco Fire/Shurjoint Piping Products.
 25. Tyco/Pentair LTD.
 26. Val-Matic Valve & Mfg. Corp.
 27. Victaulic Company.

28. Watts Regulator Company.

2.4 BRONZE BALL VALVES

C. Two-Piece, Full-Port, Bronze Ball Valves with Bronze Trim:

1. Description:
 - a. Standard: MSS SP-110.
 - b. SWP Rating: 150 psig.
 - c. CWP Rating: 600 psig.
 - d. Body Design: Two piece.
 - e. Body Material: Bronze.
 - f. Ends: Threaded.
 - g. Seats: PTFE or TFE.
 - h. Stem: Bronze.
 - i. Ball: Chrome-plated brass.
 - j. Port: Full.

2.5 IRON, SINGLE-FLANGE BUTTERFLY VALVES

A. 150 CWP, Iron, Single-Flange (Lug) Butterfly Valves:

1. Description:
 - a. Standard: MSS SP-67, Type I.
 - b. CWP Rating: 150 psig.
 - c. Body Design: Lug type; suitable for bidirectional dead-end service at rated pressure without use of downstream flange.
 - d. Body Material: ASTM A 126, cast iron or ASTM A 536, ductile iron.
 - e. Seat: EPDM.
 - f. Stem: One- or two-piece stainless steel.
 - g. Disc: Nylon 11 coated ductile iron.

B. 175 CWP, Iron, Single-Flange (Lug) Butterfly Valves:

1. Description:
 - a. Standard: MSS SP-67, Type I.
 - b. CWP Rating: 175 psig.
 - c. Body Design: Lug type; suitable for bidirectional dead-end service at rated pressure without use of downstream flange.
 - d. Body Material: ASTM A 126, cast iron or ASTM A 536, ductile iron.
 - e. Seat: EPDM.
 - f. Stem: One- or two-piece stainless steel.
 - g. Disc: Nylon 11 coated ductile iron.

C. 200 CWP, Iron, Single-Flange Butterfly Valves with EPDM Seat and Nylon 11 coated ductile Iron Disc:

1. Description:
 - a. Standard: MSS SP-67, Type I.
 - b. CWP Rating: 200 psig.
 - c. Body Design: Lug type; suitable for bidirectional dead-end service at rated pressure without use of downstream flange.
 - d. Body Material: ASTM A 126, cast iron or ASTM A 536, ductile iron.

- e. Seat: EPDM.
 - f. Stem: One- or two-piece stainless steel.
 - g. Disc: Nylon 11 coated ductile iron.
- D. 250 CWP, Iron, Single-Flange Butterfly Valves with EPDM Seat and Nylon 11 coated ductile Iron Disc:
- 1. Description:
 - a. Standard: MSS SP-67, Type I.
 - b. CWP Rating: 250 psig.
 - c. Body Design: Lug type; suitable for bidirectional dead-end service at rated pressure without use of downstream flange.
 - d. Body Material: ASTM A 126, cast iron or ASTM A 536, ductile iron.
 - e. Seat: EPDM.
 - f. Stem: One- or two-piece stainless steel.
 - g. Disc: Nylon 11 coated ductile iron.

2.6 BRONZE LIFT CHECK VALVES

- A. Class 125, Lift Check Valve:
- 1. Description:
 - a. Standard: MSS SP-80.
 - b. CWP Rating: 200 psig.
 - c. Body Design: Vertical flow.
 - d. Body Material: ASTM B 61, ASTM B 62, bronze.
 - e. Ends: Threaded.
 - f. Disc: Bronze, Type 1.

2.7 BRONZE SWING CHECK VALVES

- A. Class 150, Bronze Swing Check Valves with Bronze Disc:
- 1. Description:
 - a. Standard: MSS SP-80, Type 3.
 - b. CWP Rating: 300 psig.
 - c. Body Design: Horizontal flow.
 - d. Body Material: ASTM B 62, bronze.
 - e. Ends: Threaded.
 - f. Disc: Bronze.

2.8 IRON SWING CHECK VALVES

- A. Class 125, Iron Swing Check Valves with Metal Seats:
- 1. Description:
 - a. Standard: MSS SP-71, Type I.
 - b. NPS 2-1/2 to NPS 12, CWP Rating: 200 psig.
 - c. Body Design: Clear or full waterway.
 - d. Body Material: ASTM A 126, gray iron with bolted bonnet.
 - e. Ends: Flanged.

- f. Trim: Bronze.
- g. Gasket: Asbestos free.

2.9 BRONZE GLOBE VALVES

A. Class 150, Bronze Globe Valves with Nonmetallic Disc:

- 1. Description:
 - a. Standard: MSS SP-80, Type 2.
 - b. CWP Rating: 300 psig.
 - c. Body Material: ASTM B 62, bronze with integral seat and union-ring bonnet.
 - d. Ends: Threaded.
 - e. Stem: Bronze.
 - f. Disc: PTFE or TFE.
 - g. Packing: Teflon impregnated, asbestos free.
 - h. Handwheel: Malleable iron.

2.10 IRON GLOBE VALVES

A. Class 125, Iron Globe Valves:

- 1. Description:
 - a. Standard: MSS SP-85, Type I.
 - b. CWP Rating: 200 psig.
 - c. Body Material: ASTM A 126, gray iron with bolted bonnet.
 - d. Ends: Flanged.
 - e. Stem: Brass alloy. OS & Y.
 - f. Disc: Renewable bronze seat.
 - g. Trim: Bronze.
 - h. Packing and Gasket: Teflon impregnated, asbestos free.
 - i. Handwheel: Cast iron

2.11 LUBRICATED PLUG VALVES

A. Class 125, Regular-Gland, Lubricated Plug Valves with Threaded Ends:

- 1. Description:
 - a. Standard: MSS SP-78, Type II.
 - b. NPS 2-1/2 to NPS 12, CWP Rating: 200 psig.
 - c. Pattern: Regular or short.
 - d. Body Material: ASTM A 48 or ASTM A 126, cast iron with lubrication-sealing system.
 - e. Plug: Cast iron or bronze with sealant groove.

2.12 CHAINWHEELS

A. Description: Valve actuation assembly with sprocket rim, brackets, and chain.

- 1. Brackets: Type, number, size, and fasteners required to mount actuator on valve.
- 2. Attachment: For connection to [ball] [butterfly] [and] [plug] valve stems.

3. Sprocket Rim with Chain Guides: Ductile or cast iron, of type and size required for valve. Include zinc coating.
4. Chain: Hot-dip, galvanized steel, of size required to fit sprocket rim.

2.13 HIGH-PERFORMANCE BUTTERFLY VALVES

A. Class 300, Single-Flange, High-Performance Butterfly Valves:

1. Manufacturers: Subject to compliance with requirements, provide products by one of the following
 - a. ABZ Valve and Controls; a division of ABZ Manufacturing, Inc.
 - b. Bray Controls; a division of Bray International.
 - c. Cooper Cameron Valves; a division of Cooper Cameron Corp.
 - d. Crane Co.; Crane Valve Group; Flowseal.
 - e. Crane Co.; Crane Valve Group; Stockham Division.
 - f. DeZurik Water Controls.
 - g. Hammond Valve.
 - h. Jamesbury; a subsidiary of Metso Automation.
 - i. Milwaukee Valve Company.
 - j. NIBCO INC.
 - k. Process Development & Control, Inc.
 - l. Tyco Valves & Controls; a unit of Tyco Flow Control.
 - m. Xomox Corporation.
2. Description:
 - a. Standard: MSS SP-68.
 - b. CWP Rating: 720 psig at 100 deg F.
 - c. Body Design: Lug type; suitable for bidirectional dead-end service at rated pressure without use of downstream flange.
 - d. Body Material: Carbon steel, cast iron, or ductile iron.
 - e. Seat: Reinforced PTFE or metal.
 - f. Stem: Stainless steel; offset from seat plane.
 - g. Disc: Carbon steel.
 - h. Service: Bidirectional.

PART 3 - EXECUTION

3.1 EXAMINATION

- A. Examine piping system for compliance³ with requirements for installation tolerances and other conditions affecting performance of valves. Do not proceed with installation until unsatisfactory conditions have been corrected.
- B. Examine valve interior for cleanliness, freedom from foreign matter, and corrosion. Remove special packing materials, such as blocks, used to prevent disc movement during shipping and handling.
- C. Operate valves in positions from fully open to fully closed. Examine guides and seats made accessible by such operations.
- D. Examine threads on valve and mating pipe for form and cleanliness.

- E. Examine mating flange faces for conditions that might cause leakage. Check bolting for proper size, length, and material. Verify that gasket is of proper size, that its material composition is suitable for service, and that it is free from defects and damage.
- F. Do not attempt to repair defective valves; replace with new valves.

3.2 VALVE INSTALLATION

- A. Install valves as indicated, according to manufacturer's written instructions.
- B. Piping installation requirements are specified in other Division 23 Sections. Drawings indicate the general arrangement of piping, fittings, and specialties.
- C. Install valves with unions or flanges at each piece of equipment arranged to allow service, maintenance, and equipment removal without system shutdown.
- D. Locate valves for easy access and provide separate support where necessary.
- E. Install valves in horizontal piping with stem at or above center of pipe.
- F. Install valves in position to allow full stem movement.
- G. Install chainwheels on operators for ball, butterfly globe and plug valves NPS 4 and larger and more than 96 inches above floor.
- H. Extend the chainwheels for chains to 60 inches above finished floor.
- I. Install check valves for proper direction of flow and as follows:
 - 1. Swing Check Valves: In horizontal position with hinge pin level.
 - 2. Check Valves: In horizontal or vertical position, between flanges.
 - 3. Lift Check Valves: With stem upright and plumb.
 - 4. Install all check valves a minimum of five pipe diameters downstream of pump discharge or elbow to avoid flow turbulence. In extreme cases add flow straighteners as required to correct the turbulence.

3.3 ADJUSTING

- A. Adjust or replace valve packing after piping systems have been tested and put into service but before final adjusting and balancing. Replace valves if persistent leaking occurs.

3.4 GENERAL REQUIREMENTS FOR VALVE APPLICATIONS

- A. If valve applications are not indicated, use the following:
 - 1. Shutoff Service: Ball or butterfly valves.
 - 2. Butterfly Valve Dead-End Service: Single-flange (lug) type.
 - 3. Throttling Service except Steam: Globe valves.
 - 4. Throttling Service, Steam: Globe valves.
 - 5. Pump-Discharge Check Valves:
 - a. NPS 2 and Smaller: Bronze swing check valves with bronze disc.
 - b. NPS 2-1/2 and Larger: Iron swing check valves with lever and weight or with spring or iron, metal-seat check valves.

6. Drain Service (except Steam): Two-Piece, Full Port Bronze Ball Valves with Bronze Trim. To be installed with NPS $\frac{3}{4}$ hose thread outlet and hose cap with chain.
- B. If valves with specified SWP classes or CWP ratings are not available, the same types of valves with higher SWP classes or CWP ratings may be substituted.
- C. Select valves, except wafer types, with the following end connections:
1. For Copper Tubing, NPS 2 and Smaller: Threaded ends except where solder-joint valve-end option is indicated in valve schedules below.
 2. For Copper Tubing, NPS 2-1/2 to NPS 4: Flanged ends except where threaded valve-end option is indicated in valve schedules below.
 3. For Copper Tubing, NPS 5 and Larger: Flanged ends.
 4. For Steel Piping, NPS 2 and Smaller: Threaded ends.
 5. For Steel Piping, NPS 2-1/2 to NPS 4: Flanged ends except where threaded valve-end option is indicated in valve schedules below.
 6. For Steel Piping, NPS 5 and Larger: Flanged ends.

3.5 CHILLED-WATER VALVE SCHEDULE

- A. Pipe NPS 2 and Smaller:
1. Bronze Valves: May be provided with solder-joint ends instead of threaded ends.
 3. Ball Valves:
 - a. Piece: Two
 - b. Port: Full.
 - c. Material/Trim: Bronze with:
 - 1) Bronze trim.
 4. Bronze Swing Check Valves:
 - a. Class 150
 - b. Bronze disc.
 6. Bronze Globe Valves:
 - a. Class 125
 - b. Bronze disc.
- B. Pipe NPS 2-1/2 and Larger:
1. Iron Valves, NPS 2-1/2 to NPS 4: May be provided with threaded ends instead of flanged ends.
 2. Iron, Single-Flange Butterfly Valves, NPS 2-1/2 to NPS 12:
 - a. 200 CWP,
 - b. Seat: EPDM.
 - c. Disc: Ductile-iron.
 3. Iron Swing Check Valves: Class 125, metal seats.
 4. Iron Globe Valves: Class 125.
 5. Lubricated Plug Valves: Class 125, regular gland, flanged.

3.6 CONDENSER-WATER VALVE SCHEDULE

- A. Pipe NPS 2 and Smaller:
1. Bronze Valves: May be provided with solder-joint ends instead of threaded ends.
 3. Ball Valves:
 - a. Piece: Two
 - b. Port: Full.
 - c. Material/Trim: Bronze with:

- 1) Bronze trim.
- 4. Bronze Swing Check Valves:
 - a. Class 150
 - b. Bronze disc.
- 6. Bronze Globe Valves:
 - a. Class 125
 - b. Bronze disc.

B. Pipe NPS 2-1/2 and Larger:

- 1. Iron Valves, NPS 2-1/2 to NPS 4: May be provided with threaded ends instead of flanged ends.
- 2. Iron, Single-Flange Butterfly Valves, NPS 2-1/2 to NPS 12:
 - a. 200 CWP,
 - b. Seat: EPDM.
 - c. Disc: Ductile-iron.
- 3. Iron Swing Check Valves: Class 125, metal seats.
- 4. Iron Swing Check Valves with Closure Control, NPS 2-1/2 to NPS 12: Class 125, lever and spring.
- 6. Iron Globe Valves: Class 125.
- 7. Lubricated Plug Valves: Class 125, regular gland, flanged.

3.7 HEATING-WATER VALVE SCHEDULE

A. Pipe NPS 2 and Smaller:

- 1. Bronze Valves: May be provided with solder-joint ends instead of threaded ends.
- 3. Ball Valves:
 - a. Piece: Two
 - b. Port: Full.
 - c. Material/Trim: Bronze with:
 - 1) Bronze trim.
- 4. Bronze Swing Check Valves:
 - a. Class 150
 - b. Bronze disc.
- 6. Bronze Globe Valves:
 - a. Class 125
 - b. Bronze disc.

B. Pipe NPS 2-1/2 and Larger:

- 1. Iron Valves, NPS 2-1/2 to NPS 4: May be provided with threaded ends instead of flanged ends.
- 2. Iron, Single-Flange Butterfly Valves, NPS 2-1/2 to NPS 12:
 - a. 200 CWP,
 - b. Seat: EPDM.
 - c. Disc: Ductile-iron.
- 3. Iron Swing Check Valves: Class 125, metal seats.
- 4. Iron Globe Valves: Class 125.

3.8 LOW-PRESSURE STEAM VALVE SCHEDULE (15 PSIG OR LESS)

A. Pipe NPS 2 and Smaller:

- 1. Ball Valves:
 - a. Piece: Two

- b. Port: Full.
- c. Material/Trim: Bronze with:
 - 1) Bronze trim.
- 2. Bronze Swing Check Valves:
 - a. Class 150
 - b. Bronze disc.
- 4. Bronze Globe Valves:
 - a. Class 125
 - b. Bronze disc.

B. Pipe NPS 2-1/2 and Larger:

- 1. Iron Valves, NPS 2-1/2 to NPS 4: May be provided with threaded ends instead of flanged ends.
- 2. Iron Swing Check Valves: Class 125, metal seats.
- 3. Iron Globe Valves: NPS 2-1/2 to NPS 12: Class 125.
- 4. High-Performance Butterfly Valves: Class 300, single flange.

3.9 HIGH-PRESSURE STEAM VALVE SCHEDULE (MORE THAN 15 PSIG)

A. Pipe NPS 2 and Smaller:

- 1. Ball Valves:
 - a. Piece: Two
 - b. Port: Full.
 - c. Material/Trim: Bronze with:
 - 1) Bronze trim.
- 2. Bronze Swing Check Valves:
 - a. Class 150
 - b. Bronze disc.
- 4. Bronze Globe Valves:
 - a. Class 125
 - b. Bronze disc.

B. Pipe Sizes NPS 2-1/2 and Larger:

- 1. Iron Valves, NPS 2-1/2 to NPS 4: May be provided with threaded ends instead of flanged ends.
- 2. Iron Swing Check Valves: Class 125, metal seats.
- 3. Iron Globe Valves: NPS 2-1/2 to NPS 12: Class 125.
- 4. High-Performance Butterfly Valves: Class 300, single flange.

3.10 STEAM-CONDENSATE VALVE SCHEDULE

A. Pipe NPS 2 and Smaller:

- 1. Ball Valves:
 - a. Piece: Two
 - b. Port: Full.
 - c. Material/Trim: Bronze with:
 - 1) Bronze trim.
- 2. Bronze Swing Check Valves:
 - a. Class 150
 - b. Bronze disc.
- 4. Bronze Globe Valves:
 - a. Class 125
 - b. Bronze disc.

B. Pipe NPS 2-1/2 and Larger:

1. Iron Valves, NPS 2-1/2 to NPS 4: May be provided with threaded ends instead of flanged ends.
2. Iron Swing Check Valves: Class 125, metal seats.
3. Iron Globe Valves: NPS 2-1/2 to NPS 12: Class 125.
4. Lubricated Plug Valves: Class 125, regular gland, flanged.
5. High-Performance Butterfly Valves: Class 300, single flange.

END OF SECTION 23 0523

SECTION 23 0529

HANGERS AND SUPPORTS FOR HVAC PIPING AND EQUIPMENT

PART 1 - GENERAL

1.1 RELATED DOCUMENTS

- A. Drawings and general provisions of the Contract, including General and Supplementary Conditions and Division 01 Specification Sections, apply to this Section.

1.2 SUMMARY

- A. Section Includes:

1. Metal pipe hangers and supports.
2. Trapeze pipe hangers.
3. Metal framing systems.

- B. Related Sections:

1. Division 05 Section "Metal Fabrications" for structural-steel shapes and plates for trapeze hangers for pipe and equipment supports.
2. Division 23 Section "Vibration and Seismic Controls for HVAC" for vibration isolation devices.
3. Division 23 Section "Metal Ducts" for duct hangers and supports.

1.3 DEFINITIONS

- A. MSS: Manufacturers Standardization Society of The Valve and Fittings Industry Inc.

1.4 PERFORMANCE REQUIREMENTS

- A. Structural Performance: Hangers and supports for HVAC piping and equipment shall withstand the effects of gravity loads and stresses within limits and under conditions indicated according to ASCE/SEI 7.
 1. Design supports for multiple pipes, including pipe stands, capable of supporting combined weight of supported systems, system contents, and test water.
 2. Design equipment supports capable of supporting combined operating weight of supported equipment and connected systems and components.
 3. Design seismic-restraint hangers and supports for piping and equipment.

1.5 ACTION SUBMITTALS

- A. Product Data: For each type of product indicated.
- B. Shop Drawings: Signed and sealed by a qualified professional engineer. Show fabrication and installation details and include calculations for the following; include Product Data for components:
 1. Trapeze pipe hangers.

2. Metal framing systems.

1.6 INFORMATIONAL SUBMITTALS

- A. Welding certificates.

PART 2 - PRODUCTS

2.1 METAL PIPE HANGERS AND SUPPORTS

- A. Carbon-Steel Pipe Hangers and Supports:
 1. Description: MSS SP-58, Types 1 through 58, factory-fabricated components.
 2. Galvanized Metallic Coatings: Pre-galvanized or hot dipped.
 3. Nonmetallic Coatings: Plastic coating, jacket, or liner.
 4. Padded Hangers: Hanger with fiberglass or other pipe insulation pad or cushion to support bearing surface of piping.
 5. Hanger Rods: Continuous-thread rod, nuts, and washer made of carbon steel.

2.2 TRAPEZE PIPE HANGERS

- A. Description: MSS SP-69, Type 59, shop- or field-fabricated pipe-support assembly made from structural carbon-steel shapes with MSS SP-58 carbon-steel hanger rods, nuts, saddles, and U-bolts.

2.3 METAL FRAMING SYSTEMS

- A. MFMA Manufacturer Metal Framing Systems:
 1. Manufacturers: Subject to compliance with requirements, provide products by one of the following:
 - a. Anvil International.
 - b. Cooper B-Line, Inc.; a division of Cooper Industries.
 - c. ERICO/Michigan Hanger Co. ; ERISTRUT Div.
 - d. GS Metals Corp.
 - e. Hilti, Inc.
 - f. Power-Strut Div. Tyco International.
 - g. Thomas & Betts Corporation.
 - h. Tolco Inc.
 - i. Unistrut; an Atkore International company.
 2. Description: Shop- or field-fabricated pipe-support assembly for supporting multiple parallel pipes.
 3. Standard: MFMA-4.
 4. Channels: Continuous slotted steel channel with inturned lips.
 5. Channel Nuts: Formed or stamped steel nuts or other devices designed to fit into channel slot and, when tightened, prevent slipping along channel.
 6. Hanger Rods: Continuous-thread rod, nuts, and washer made of carbon steel.
 7. Metallic Coating:
 - a. Electroplated zinc.

- B. Non-MFMA Manufacturer Metal Framing Systems:

1. Manufacturers: Subject to compliance with requirements, provide products by one of the following:
 - a. Anvil International; a subsidiary of Mueller Water Products, Inc.
 - b. Empire Industries, Inc.
 - c. ERICO International Corporation.
 - d. Haydon Corporation.
 - e. NIBCO INC.
 - f. PHD Manufacturing, Inc.
 - g. PHS Industries, Inc.
2. Description: Shop- or field-fabricated pipe-support assembly made of steel channels, accessories, fittings, and other components for supporting multiple parallel pipes.
3. Standard: Comply with MFMA-4.
4. Channels: Continuous slotted steel channel with inturned lips.
5. Channel Nuts: Formed or stamped steel nuts or other devices designed to fit into channel slot and, when tightened, prevent slipping along channel.
6. Hanger Rods: Continuous-thread rod, nuts, and washer made of carbon steel.
7. Coating:
 - a. Zinc.

2.4 THERMAL-HANGER SHIELD INSERTS

- A. Manufacturers: Subject to compliance with requirements, provide products by one of the following:
 1. Carpenter & Paterson, Inc.
 2. Clement Support Services.
 3. ERICO International Corporation.
 4. National Pipe Hanger Corporation.
 5. PHS Industries, Inc.
 6. Pipe Shields Inc.
 7. Piping Technology & Products, Inc.
 8. Rilco Manufacturing Co., Inc.
 9. Value Engineered Products, Inc.
- B. Insulation-Insert Material for Cold Piping:
 1. Water-repellent treated, ASTM C 533, Type I calcium silicate with 100-psig minimum compressive strength.
- C. Insulation-Insert Material for Hot Piping:
 1. Water-repellent treated, ASTM C 533, Type I calcium silicate with 100-psig minimum compressive strength.
- D. For Trapeze or Clamped Systems: Insert and shield shall cover entire circumference of pipe.
- E. For Clevis or Band Hangers: Insert and shield shall cover lower 180 degrees of pipe.
- F. Insert Length: Extend 2 inches beyond sheet metal shield for piping operating below ambient air temperature.

2.5 FASTENER SYSTEMS

- A. Powder-Actuated Fasteners: Threaded-steel stud, for use in hardened portland cement concrete with pull-out, tension, and shear capacities appropriate for supported loads and building materials where used.

- B. Mechanical-Expansion Anchors: Insert-wedge-type, [zinc-coated] [stainless-] steel anchors, for use in hardened portland cement concrete; with pull-out, tension, and shear capacities appropriate for supported loads and building materials where used.

2.6 MISCELLANEOUS MATERIALS

- A. Structural Steel: ASTM A 36, carbon-steel plates, shapes, and bars; black and galvanized.
- B. Grout: ASTM C 1107, factory-mixed and -packaged, dry, hydraulic-cement, nonshrink and nonmetallic grout; suitable for interior and exterior applications.
 - 1. Properties: Nonstaining, noncorrosive, and nongaseous.
 - 2. Design Mix: 5000-psi, 28-day compressive strength.

PART 3 - EXECUTION

3.1 HANGER AND SUPPORT INSTALLATION

- A. Comply with SEI/ASCE 7 and with requirements for seismic-restraint devices in Section 230548 "Vibration and Seismic Controls for HVAC."
- B. Metal Pipe-Hanger Installation: Comply with MSS SP-69 and MSS SP-89. Install hangers, supports, clamps, and attachments as required to properly support piping from the building structure.
- C. Metal Trapeze Pipe-Hanger Installation: Comply with MSS SP-69 and MSS SP-89. Arrange for grouping of parallel runs of horizontal piping, and support together on field-fabricated trapeze pipe hangers.
 - 1. Pipes of Various Sizes: Support together and space trapezes for smallest pipe size or install intermediate supports for smaller diameter pipes as specified for individual pipe hangers.
 - 2. Field fabricate from ASTM A 36, carbon-steel shapes selected for loads being supported. Weld steel according to AWS D1.1.
- D. Metal Framing System Installation: Arrange for grouping of parallel runs of piping, and support together on field-assembled metal framing systems.
- E. Install hangers and supports complete with necessary attachments, inserts, bolts, rods, nuts, washers, and other accessories.
- F. Install hangers and supports to allow controlled thermal and seismic movement of piping systems, to permit freedom of movement between pipe anchors, and to facilitate action of expansion joints, expansion loops, expansion bends, and similar units.
- G. Install lateral bracing with pipe hangers and supports to prevent swaying.
- H. Install building attachments within concrete slabs or attach to structural steel. Install additional attachments at concentrated loads, including valves, flanges, and strainers, NPS 2-1/2 and larger and at changes in direction of piping. Install concrete inserts before concrete is placed; fasten inserts to forms and install reinforcing bars through openings at top of inserts.
- I. Load Distribution: Install hangers and supports so that piping live and dead loads and stresses from movement will not be transmitted to connected equipment.

- J. Pipe Slopes: Install hangers and supports to provide indicated pipe slopes and to not exceed maximum pipe deflections allowed by ASME B31.9 for building services piping.
- K. Insulated Piping:
 - 1. Attach clamps and spacers to piping.
 - a. Piping Operating above Ambient Air Temperature: Clamp may project through insulation.
 - b. Piping Operating below Ambient Air Temperature: Use thermal-hanger shield insert with clamp sized to match OD of insert.
 - c. Do not exceed pipe stress limits allowed by ASME B31.9 for building services piping.
 - 2. Install MSS SP-58, Type 39, protection saddles if insulation without vapor barrier is indicated. Fill interior voids with insulation that matches adjoining insulation.
 - a. Option: Thermal-hanger shield inserts may be used. Include steel weight-distribution plate for pipe NPS 4 and larger if pipe is installed on rollers.
 - 3. Install MSS SP-58, Type 40, protective shields on cold piping with vapor barrier. Shields shall span an arc of 180 degrees.
 - a. Option: Thermal-hanger shield inserts may be used. Include steel weight-distribution plate for pipe NPS 4 and larger if pipe is installed on rollers.
 - 4. Shield Dimensions for Pipe: Not less than the following:
 - a. NPS 1/4 to NPS 3-1/2: 12 inches long and 0.048 inch thick.
 - b. NPS 4: 12 inches long and 0.06 inch thick.
 - c. NPS 5 and NPS 6: 18 inches long and 0.06 inch thick.
 - d. NPS 8 to NPS 14: 24 inches long and 0.075 inch thick.
 - e. NPS 16 to NPS 24: 24 inches long and 0.105 inch thick.
 - 5. Pipes NPS 8 and Larger: Include wood or reinforced calcium-silicate-insulation inserts of length at least as long as protective shield.
 - 6. Thermal-Hanger Shields: Install with insulation same thickness as piping insulation.

3.2 METAL FABRICATIONS

- A. Cut, drill, and fit miscellaneous metal fabrications for trapeze pipe hangers.
- B. Fit exposed connections together to form hairline joints. Field weld connections that cannot be shop welded because of shipping size limitations.
- C. Field Welding: Comply with AWS D1.1/D1.1M procedures for shielded, metal arc welding; appearance and quality of welds; and methods used in correcting welding work; and with the following:
 - 1. Use materials and methods that minimize distortion and develop strength and corrosion resistance of base metals.
 - 2. Obtain fusion without undercut or overlap.
 - 3. Remove welding flux immediately.
 - 4. Finish welds at exposed connections so no roughness shows after finishing and so contours of welded surfaces match adjacent contours.

3.3 ADJUSTING

- A. Hanger Adjustments: Adjust hangers to distribute loads equally on attachments and to achieve indicated slope of pipe.
- B. Trim excess length of continuous-thread hanger and support rods to 1-1/2 inches.

3.4 PAINTING

- A. Touchup: Cleaning and touchup painting of field welds, bolted connections, and abraded areas of shop paint on miscellaneous metal are specified in Division 09.
- B. Galvanized Surfaces: Clean welds, bolted connections, and abraded areas and apply galvanizing-repair paint to comply with ASTM A 780.

3.5 HANGER AND SUPPORT SCHEDULE

- A. Specific hanger and support requirements are in Sections specifying piping systems and equipment.
- B. Comply with MSS SP-69 for pipe-hanger selections and applications that are not specified in piping system Sections.
- C. Use hangers and supports with galvanized metallic coatings for piping and equipment that will not have field-applied finish.
- D. Use nonmetallic coatings on attachments for electrolytic protection where attachments are in direct contact with copper tubing.
- E. Use carbon-steel pipe hangers and supports and attachments for general service applications.
- F. Use padded hangers for piping that is subject to scratching.
- G. Use thermal-hanger shield inserts for insulated piping and tubing.
- H. Horizontal-Piping Hangers and Supports: Unless otherwise indicated and except as specified in piping system Sections, install the following types:
 - 1. Adjustable, Steel Clevis Hangers (MSS Type 1): For suspension of noninsulated or insulated, stationary pipes NPS 1/2 to NPS 30.
 - 2. Yoke-Type Pipe Clamps (MSS Type 2): For suspension of up to 1050 deg F, pipes NPS 4 to NPS 24, requiring up to 4 inches of insulation.
 - 3. Carbon- or Alloy-Steel, Double-Bolt Pipe Clamps (MSS Type 3): For suspension of pipes NPS 3/4 to NPS 36, requiring clamp flexibility and up to 4 inches of insulation.
 - 4. Steel Pipe Clamps (MSS Type 4): For suspension of cold and hot pipes NPS 1/2 to NPS 24 if little or no insulation is required.
 - 5. Pipe Hangers (MSS Type 5): For suspension of pipes NPS 1/2 to NPS 4, to allow off-center closure for hanger installation before pipe erection.
 - 6. Adjustable, Swivel Split- or Solid-Ring Hangers (MSS Type 6): For suspension of noninsulated, stationary pipes NPS 3/4 to NPS 8.
 - 7. Adjustable, Steel Band Hangers (MSS Type 7): For suspension of noninsulated, stationary pipes NPS 1/2 to NPS 8.
 - 8. Adjustable Band Hangers (MSS Type 9): For suspension of noninsulated, stationary pipes NPS 1/2 to NPS 8.
 - 9. Adjustable, Swivel-Ring Band Hangers (MSS Type 10): For suspension of noninsulated, stationary pipes NPS 1/2 to NPS 8.

10. Split Pipe Ring with or without Turnbuckle Hangers (MSS Type 11): For suspension of noninsulated, stationary pipes NPS 3/8 to NPS 8.
 11. Extension Hinged or Two-Bolt Split Pipe Clamps (MSS Type 12): For suspension of noninsulated, stationary pipes NPS 3/8 to NPS 3.
 12. U-Bolts (MSS Type 24): For support of heavy pipes NPS 1/2 to NPS 30.
 13. Clips (MSS Type 26): For support of insulated pipes not subject to expansion or contraction.
 14. Pipe Saddle Supports (MSS Type 36): For support of pipes NPS 4 to NPS 36, with steel-pipe base stanchion support and cast-iron floor flange or carbon-steel plate.
 15. Pipe Stanchion Saddles (MSS Type 37): For support of pipes NPS 4 to NPS 36, with steel-pipe base stanchion support and cast-iron floor flange or carbon-steel plate, and with U-bolt to retain pipe.
 16. Adjustable Pipe Saddle Supports (MSS Type 38): For stanchion-type support for pipes NPS 2-1/2 to NPS 36 if vertical adjustment is required, with steel-pipe base stanchion support and cast-iron floor flange.
 17. Single-Pipe Rolls (MSS Type 41): For suspension of pipes NPS 1 to NPS 30, from two rods if longitudinal movement caused by expansion and contraction might occur.
 18. Adjustable Roller Hangers (MSS Type 43): For suspension of pipes NPS 2-1/2 to NPS 24, from single rod if horizontal movement caused by expansion and contraction might occur.
 19. Complete Pipe Rolls (MSS Type 44): For support of pipes NPS 2 to NPS 42 if longitudinal movement caused by expansion and contraction might occur but vertical adjustment is not necessary.
 20. Pipe Roll and Plate Units (MSS Type 45): For support of pipes NPS 2 to NPS 24 if small horizontal movement caused by expansion and contraction might occur and vertical adjustment is not necessary.
 21. Adjustable Pipe Roll and Base Units (MSS Type 46): For support of pipes NPS 2 to NPS 30 if vertical and lateral adjustment during installation might be required in addition to expansion and contraction.
- I. Vertical-Piping Clamps: Unless otherwise indicated and except as specified in piping system Sections, install the following types:
1. Extension Pipe or Riser Clamps (MSS Type 8): For support of pipe risers NPS 3/4 to NPS 24.
 2. Carbon- or Alloy-Steel Riser Clamps (MSS Type 42): For support of pipe risers NPS 3/4 to NPS 24 if longer ends are required for riser clamps.
- J. Hanger-Rod Attachments: Unless otherwise indicated and except as specified in piping system Sections, install the following types:
1. Steel Turnbuckles (MSS Type 13): For adjustment up to 6 inches for heavy loads.
 2. Steel Clevises (MSS Type 14): For 120 to 450 deg F piping installations.
 3. Swivel Turnbuckles (MSS Type 15): For use with MSS Type 11, split pipe rings.
 4. Malleable-Iron Sockets (MSS Type 16): For attaching hanger rods to various types of building attachments.
 5. Steel Weldless Eye Nuts (MSS Type 17): For 120 to 450 deg F piping installations.
- K. Building Attachments: Unless otherwise indicated and except as specified in piping system Sections, install the following types:
1. Steel or Malleable Concrete Inserts (MSS Type 18): For upper attachment to suspend pipe hangers from concrete ceiling.
 2. Top-Beam C-Clamps (MSS Type 19): For use under roof installations with bar-joint construction, to attach to top flange of structural shape.
 3. Side-Beam or Channel Clamps (MSS Type 20): For attaching to bottom flange of beams, channels, or angles.
 4. Center-Beam Clamps (MSS Type 21): For attaching to center of bottom flange of beams.

5. Welded Beam Attachments (MSS Type 22): For attaching to bottom of beams if loads are considerable and rod sizes are large.
 6. C-Clamps (MSS Type 23): For structural shapes.
 7. Top-Beam Clamps (MSS Type 25): For top of beams if hanger rod is required tangent to flange edge.
 8. Side-Beam Clamps (MSS Type 27): For bottom of steel I-beams.
 9. Steel-Beam Clamps with Eye Nuts (MSS Type 28): For attaching to bottom of steel I-beams for heavy loads.
 10. Linked-Steel Clamps with Eye Nuts (MSS Type 29): For attaching to bottom of steel I-beams for heavy loads, with link extensions.
 11. Malleable-Beam Clamps with Extension Pieces (MSS Type 30): For attaching to structural steel.
 12. Welded-Steel Brackets: For support of pipes from below or for suspending from above by using clip and rod. Use one of the following for indicated loads:
 - a. Light (MSS Type 31): 750 lb.
 - b. Medium (MSS Type 32): 1500 lb.
 - c. Heavy (MSS Type 33): 3000 lb.
 13. Side-Beam Brackets (MSS Type 34): For sides of steel or wooden beams.
 14. Plate Lugs (MSS Type 57): For attaching to steel beams if flexibility at beam is required.
 15. Horizontal Travelers (MSS Type 58): For supporting piping systems subject to linear horizontal movement where headroom is limited.
- L. Saddles and Shields: Unless otherwise indicated and except as specified in piping system Sections, install the following types:
1. Steel-Pipe-Covering Protection Saddles (MSS Type 39): To fill interior voids with insulation that matches adjoining insulation.
 2. Protection Shields (MSS Type 40): Of length recommended in writing by manufacturer to prevent crushing insulation.
 3. Thermal-Hanger Shield Inserts: For supporting insulated pipe.
- M. Spring Hangers and Supports: Unless otherwise indicated and except as specified in piping system Sections, install the following types:
1. Restraint-Control Devices (MSS Type 47): Where indicated to control piping movement.
 2. Spring Cushions (MSS Type 48): For light loads if vertical movement does not exceed 1-1/4 inches.
 3. Spring-Cushion Roll Hangers (MSS Type 49): For equipping Type 41, roll hanger with springs.
 4. Spring Sway Braces (MSS Type 50): To retard sway, shock, vibration, or thermal expansion in piping systems.
 5. Variable-Spring Hangers (MSS Type 51): Preset to indicated load and limit variability factor to 25 percent to allow expansion and contraction of piping system from hanger.
 6. Variable-Spring Base Supports (MSS Type 52): Preset to indicated load and limit variability factor to 25 percent to allow expansion and contraction of piping system from base support.
 7. Variable-Spring Trapeze Hangers (MSS Type 53): Preset to indicated load and limit variability factor to 25 percent to allow expansion and contraction of piping system from trapeze support.
 8. Constant Supports: For critical piping stress and if necessary to avoid transfer of stress from one support to another support, critical terminal, or connected equipment. Include auxiliary stops for erection, hydrostatic test, and load-adjustment capability. These supports include the following types:
 - a. Horizontal (MSS Type 54): Mounted horizontally.
 - b. Vertical (MSS Type 55): Mounted vertically.
 - c. Trapeze (MSS Type 56): Two vertical-type supports and one trapeze member.

- N. Comply with MSS SP-69 for trapeze pipe-hanger selections and applications that are not specified in piping system Sections.
- O. Comply with MFMA-103 for metal framing system selections and applications that are not specified in piping system Sections.
- P. Use powder-actuated fasteners or mechanical-expansion anchors instead of building attachments where required in concrete construction.

END OF SECTION 23 0529

THIS PAGE LEFT BLANK INTENTIONALLY

SECTION 23 0548

VIBRATION AND SEISMIC CONTROLS FOR HVAC

PART 1 - GENERAL

1.1 RELATED DOCUMENTS

- A. Drawings and general provisions of the Contract, including General and Supplementary Conditions and Division 01 Specification Sections, apply to this Section.

1.2 SCOPE

- A. Provide engineered vibration isolation and restraint systems in accordance with the requirements of this section including design, engineering, materials, testing, inspections and reports.
- B. Mechanical equipment with moving parts shall be mounted on or suspended from vibration isolators to reduce the transmission of vibration and mechanically transmitted sound to the building structure.
- C. All mechanical equipment, piping and ductwork shall be restrained as required by Federal, State and Local building codes to preserve the integrity of nonstructural building components during seismic events to minimize hazards to occupants and reduce property damage.

1.3 SUMMARY

- A. This Section includes the following:
 - 1. Elastomeric isolation pads.
 - 2. Elastomeric isolation mounts.
 - 3. Restrained elastomeric isolation mounts.
 - 4. Open-spring isolators.
 - 5. Housed-spring isolators.
 - 6. Restrained-spring isolators.
 - 7. Housed-restrained-spring isolators.
 - 8. Pipe-riser resilient supports.
 - 9. Resilient pipe guides.
 - 10. Air-spring isolators.
 - 11. Restrained-air-spring isolators.
 - 12. Elastomeric hangers.
 - 13. Spring hangers.
 - 14. Snubbers.
 - 15. Restraint channel bracings.
 - 16. Restraint cables.
 - 17. Seismic-restraint accessories.
 - 18. Mechanical anchor bolts.
 - 19. Adhesive anchor bolts.
 - 20. Vibration isolation equipment bases.
 - 21. Restrained isolation roof-curb rails.
 - 22. Certification of seismic restraint designs.
 - 23. Installation supervision.
 - 24. Design of attachment of housekeeping pads.
 - 25. All components requiring IBC compliance and certification.

26. All inspection and test procedures for components requiring IBC compliance.
27. Restraint of all mechanical equipment, pipe and ductwork, within, on, or outdoors of the building and entry of services to the building, up to but not including, the utility connection, is part of this Specification.
28. Seismic certification of equipment

B. Related Requirements:

1. Division 22 Section "Vibration and Seismic Controls for Plumbing Piping and Equipment" for devices for plumbing equipment and systems.
2. Division 03 Section "Cast-in-Place Concrete."
3. Division 07 Section "Roof Accessories"
4. Division 23 Section "Hydronic Piping"

1.4 DEFINITIONS

A. IBC: International Building Code.

B. ICC-ES: ICC-Evaluation Service.

C. ASCE: American Society of Civil Engineers

D. Ip: Importance Factor.

E. ESSENTIAL FACILITIES, (Occupancy Category IV, IBC-2018)

1. Buildings and other structures that are intended to remain operational in the event of extreme environmental loading from flood, wind, snow or earthquakes.

F. LIFE SAFETY

1. All systems involved with fire protection, including sprinkler piping, jockey pumps, fire pumps, control panels, service water supply piping, water tanks, fire dampers, smoke exhaust systems and fire alarm panels.
2. All mechanical, electrical, plumbing or fire protection systems that support the operation of, or are connected to, emergency power equipment, including all lighting, generators, transfer switches and transformers.
3. All medical and life support systems.
4. Hospital heating systems and air conditioning systems for maintaining normal ambient temperature.
5. Automated supply, exhaust, fresh air and relief air systems on emergency control sequence, including air handlers, duct, dampers, etc., or manually-operated systems used for smoke evacuation, purge or fresh air relief by the fire department.
6. Heating systems in any facility with Occupancy Category IV, IBC-2018 where the ambient temperature can fall below 32 degrees Fahrenheit.

G. HIGH HAZARD

1. All gases or fluids that must be contained in a closed system which are flammable or combustible. Any gas that poses a health hazard if released into the environment and vented Fuel Cells.

1.5 REFERENCE CODES AND STANDARDS

- A. Codes and Standards: The following shall apply and conform to good engineering practices unless otherwise directed by the Federal, State or Local authorities having jurisdiction.
1. IBC
 2. ASCE 7
 3. NFPA 13 (National Fire Protection Association)
 4. IBC 2018
- B. The following guides may be used for supplemental information on typical seismic installation practices. Where a conflict exists between the guides and these construction documents, the construction documents will preside.
1. FEMA (Federal Emergency Management Agency) manuals 412, Installing Seismic Restraints for Mechanical Equipment and 414, Installing Seismic Restraints for Ductwork and Pipe.
 2. SMACNA (Sheet Metal and Air-conditioning Contractors' National Association) Seismic Restraint Manual Guidelines for Mechanical Systems, 3rd ed.
 3. ASHRAE (American Society for Heating, Refrigerating and Air-conditioning Engineers) A Practical Guide to Seismic Restraint
 4. MSS (Manufacturers Standardization Society of the Valve and Fittings Industry) MSS SP-127, Bracing for Piping Systems, Seismic – Wind – Dynamic, Design, Selection, Application.

1.6 ISOLATOR AND RESTRAINT MANUFACTURER'S RESPONSIBILITIES:

- A. Provide project specific vibration isolation and seismic restraint design prepared by a registered design professional in the state where the project is being constructed, and manufacturer certifications that the components are seismically qualified.
1. Provide calculations to determine restraint loads resulting from seismic forces as required by IBC, Chapter 16 and ASCE 7, latest editions. Seismic calculations shall be certified by an engineer licensed in the state where the project is being constructed.
- B. Provide installation instructions and shop drawings for all materials supplied under this section of the specifications.
1. Provide seismic restraint details with specific information relating to the materials, type, size, and locations of anchorages; materials used for bracing; attachment requirements of bracing to structure and component; and locations of transverse and longitudinal sway bracing and rod stiffeners.
 2. Provide seismic bracing layout drawings indicating the location of all seismic restraints.
 - a. Each piece of rotating isolated equipment shall be tagged to clearly identify quantity and size of vibration isolators and seismic restraints.
- C. Provide, in writing, the special inspection requirements for all Designated Seismic Systems as indicated in Chapter 17 of the IBC.
- D. Provide training for installation, operation and maintenance of isolation and restraint systems.

1.7 PERFORMANCE REQUIREMENTS

- A. Wind-Restraint Loading: Per the structural drawings and specifications.
- B. Flood-Restraint Loading: Per the structural drawings and specifications.
- C. Seismic-Restraint Loading:
 - 1. Site Class as Defined in the IBC: Per the structural drawings and specifications. See structural general notes drawing S-001.
 - 2. Assigned Occupancy Category as Defined in the IBC: Per the structural drawings and specifications.
 - a. Component Importance Factor: 1.5.
 - 1) Life safety components required to function after an earthquake.
 - 2) Components containing hazardous or flammable materials in quantities that exceed the exempted amounts for an open system listed in Chapter 4.
 - 3) For structures with an Occupancy Category IV, components needed for continued operation of the facility or whose failure could impair the continued operation of the facility.
 - 4) Storage racks in occupancies open to the general public (e.g., warehouse retail stores).
 - b. Component Importance Factor: 1.0.
 - 1) All other components
 - c. Component Response Modification Factor: Per the structural drawings and specifications.
 - d. Component Amplification Factor: Per the structural drawings and specifications.
 - 3. Design Spectral Response Acceleration at Short Periods: Per the structural drawings and specifications.
 - 4. Design Spectral Response Acceleration at 1-Second Period: Per the structural drawings and specifications.

1.8 ACTION SUBMITTALS

- A. Product Data: For the following:
 - 1. Submittals shall include catalog cut sheets and installation instructions for each type of anchor and seismic restraint used on equipment or components being isolated and/or restrained.
 - 2. Submittals for mountings and hangers incorporating springs shall include spring diameter and free height, rated load, rated deflection, and overload capacity for each vibration isolation device.
 - 3. Illustrate and indicate style, material, strength, fastening provision, and finish for each type and size of seismic-restraint component used.
 - a. Tabulate types and sizes of seismic restraints, complete with report numbers and rated strength in tension and shear as evaluated by an evaluation service member of ICC-ES.
 - b. Annotate to indicate application of each product submitted and compliance with requirements.
 - 4. Interlocking Snubbers: Include ratings for horizontal, vertical, and combined loads.
- B. Shop Drawings:

1. Detail fabrication and assembly of equipment bases. Detail fabrication including anchorages and attachments to structure and to supported equipment. Include adjustable motor bases, rails, and frames for equipment mounting.
- C. Delegated-Design Submittal: For vibration isolation and seismic-restraint details indicated to comply with performance requirements and design criteria, including analysis data signed and sealed by the qualified professional engineer responsible for their preparation.
1. "Basis for Design" report: Statement from the registered design professional that the design complies with the requirements of the ASCE 7-05 Chapter 13, IBC 2052 chapter 1912 and ACI 318. In addition, the basis for compliance must also be noted, as listed below:
 - a. Project specific design documentation prepared and submitted by a registered design professional (ASCE 7, 13.2.1.1)
 - b. Submittal of the manufacturer's certification that the isolation equipment is seismically qualified by:
 - c. An engineered analysis conforming to the requirements of Chapter 13 of ASCE 7.
 - d. Testing by a nationally recognized testing standard procedure such as ICC-ES AC 156. The substantiated seismic design capacities shall exceed the seismic demands determined by Section 13.3 of ASCE 7.
 - e. Experience data conforming to a nationally recognized procedure. The substantiated seismic design capacities shall exceed the seismic demands determined by Section 13.3 of ASCE 7.
 2. Seismic restraint load ratings must be certified and substantiated by testing or calculations under direct control of a registered professional engineer. Copies of testing and calculations must be submitted as part of submittal documents.
 3. Include design calculations and details for selecting vibration isolators, seismic restraints, and vibration isolation bases complying with performance requirements, design criteria, and analysis data signed and sealed by the qualified professional engineer responsible for their preparation.
 4. Design Calculations: Calculate static and dynamic loading due to equipment weight and operation, seismic forces required to select vibration isolators, seismic restraints, and for designing vibration isolation bases.
 - a. Coordinate design calculations with wind load calculations required for equipment mounted outdoors. Comply with requirements in other Division 23 Sections for equipment mounted outdoors.
 5. Riser Supports: Include riser diagrams and calculations showing anticipated expansion and contraction at each support point, initial and final loads on building structure, spring deflection changes, and seismic loads. Include certification that riser system has been examined for excessive stress and that none will exist.
 6. Vibration Isolation Base Details: Detail overall dimensions, including anchorages and attachments to structure and to supported equipment. Include auxiliary motor slides and rails, base weights, equipment static loads, power transmission, component misalignment, and cantilever loads.
 7. Seismic-Restraint Details:
 - a. Design Analysis: To support selection and arrangement of seismic restraints. Include calculations of combined tensile and shear loads.
 - b. Details: Indicate fabrication and arrangement. Detail attachments of restraints to the restrained items and to the structure. Show attachment locations, methods, and spacings. Identify components, list their strengths, and indicate directions and values of forces transmitted to the structure during seismic events. Indicate association with vibration isolation devices.

- c. Preapproval and Evaluation Documentation: By an evaluation service member of ICC-ES, showing maximum ratings of restraint items and the basis for approval (tests or calculations).

1.9 INFORMATIONAL SUBMITTALS

- A. Coordination Drawings: Show coordination of seismic bracing for HVAC piping and equipment with other systems and equipment in the vicinity, including other supports and seismic restraints.
 - 1. Submittal drawings and calculations must be stamped by a registered professional engineer in the State where the project is being constructed who is responsible for the seismic restraint design.
 - 2. Calculations and restraint device submittal drawings shall specify anchor bolt type, embedment, concrete compressive strength, minimum spacing between anchors, and minimum distances of anchors from concrete edges. Concrete anchor locations shall not be near edges, stress joints, or an existing fracture. All bolts shall be ASTM A307 or better.
- B. Qualification Data: For professional engineer and testing agency.
- C. Welding certificates.
- D. Field quality-control test reports.

1.10 QUALITY ASSURANCE

- A. Testing Agency Qualifications: An independent agency, with the experience and capability to conduct the testing indicated, that is a nationally recognized testing laboratory (NRTL) as defined by OSHA in 29 CFR 1910.7, and that is acceptable to authorities having jurisdiction.
- B. Comply with seismic-restraint requirements in the IBC unless requirements in this Section are more stringent.
- C. Welding: Qualify procedures and personnel according to AWS D1.1/D1.1M, "Structural Welding Code - Steel."
- D. Seismic-restraint devices shall have horizontal and vertical load testing and analysis and shall bear anchorage preapproval by ICC-ES, or preapproval by another agency acceptable to authorities having jurisdiction, showing maximum seismic-restraint ratings. Ratings based on independent testing are preferred to ratings based on calculations. If preapproved ratings are not available, submittals based on independent testing are preferred. Calculations (including combining shear and tensile loads) to support seismic-restraint designs must be signed and sealed by a qualified professional engineer.

1.11 SEISMIC CERTIFICATION OF EQUIPMENT

- A. Component Importance Factor. All plumbing and mechanical components shall be assigned a component importance factor. The component importance factor, I_p , shall be taken as 1.5 if any of the following conditions apply:
 - 1. The component is required to function for life-safety purposes after an earthquake.
 - 2. The component contains hazardous materials.

3. The component is in or attached to an Occupancy Category IV structure and it is needed for continued operation of the facility or its failure could impair the continued operation of the facility.
- B. All other components shall be assigned a component importance factor, I_p , equal to 1.0.
- C. For equipment or components where $I_p = 1.0$.
1. Submit manufacturer's certification that the equipment is seismically qualified by:
 - a. An engineered analysis conforming to the requirements of Chapter 13 of ASCE 7.
 - b. Testing by a nationally recognized testing standard procedure such as ICC-ES AC 156. The substantiated seismic design capacities shall exceed the seismic demands determined by Section 13.3 of ASCE 7.
 - c. Experience data conforming to a nationally recognized procedure. The substantiated seismic design capacities shall exceed the seismic demands determined by Section 13.3 of ASCE 7.
 2. The equipment and components listed below are considered rugged and shall not require Special Seismic Certification:
 - a. Valves (not in cast-iron housings, except for ductile cast iron).
 - b. Pneumatic operators.
 - c. Hydraulic operators.
 - d. Motors and motor operators.
 - e. Horizontal and vertical pumps (including vacuum pumps).
 - f. Air compressors
 - g. Refrigerators and freezers.
 - h. Elevator cabs.
 - i. Underground tanks.
 - j. Equipment and components weighing not more than 20 lbs. supported directly on structures (and not mounted on other equipment or components) with supports and attachments in accordance with Chapter 13, ASCE 7.
 3. Rugged equipment and components in this section are for factory assembled discrete equipment and components only and do not apply to site assembled or field assembled equipment or equipment anchorage.
- D. Special Certification requirements for Designated Seismic Systems (i.e. $I_p = 1.5$): Seismic Certificates of Compliance supplied by manufacturers shall be submitted for all components that are part of Designated Seismic Systems. In accordance with the ASCE 7, certification shall be via one of the following methods:
1. For active mechanical and electrical equipment that must remain operable following the design earthquake:
 - a. Testing as detailed by part C.1.b above.
 - b. Experience data as detailed by part C.1.c above.
 - c. Equipment that is considered "rugged" per part C.2 above.
 2. Components with hazardous contents shall be certified by the manufacturer as maintaining containment following the design earthquake by:
 - a. Testing as detailed by part C.1.b above.
 - b. Experience data as detailed by part C.1.c above.
 - c. Engineering analysis utilizing dynamic characteristics and forces. Tanks (without vibration isolators) designed by a registered design professional in accordance with ASME Boiler and Pressure Vessel Code, and satisfying the force and

displacement requirements of Sections 13.3.1 and 13.3.2 of ASCE 7 having an importance factor, $I_p = 1.0$ shall be considered to satisfy the Special Seismic Certification requirements on the basis of ASCE 7 Section 13.6.9.

PART 2 - PRODUCTS

2.1 VIBRATION ISOLATORS

- A. Manufacturers: Subject to compliance with requirements, provide products by one of the following:
1. Amber/Booth Company, Inc.
 2. CalDyn (California Dynamics Corporation).
 3. ISAT (International Seismic Application Technology).
 4. Kinetics Noise Control.
 5. Mason Industries.
 6. Vibro-Acoustics
 7. VMC (Vibration Mountings & Controls, Inc.)
- B. Elastomeric Isolation Pads P1:
1. Fabrication: Single or multiple layers of sufficient durometer stiffness for uniform loading over pad area.
 2. Size: Factory or field cut to match requirements of supported equipment.
 3. Pad Material: Oil and water resistant with elastomeric properties.
 4. Surface Pattern: Ribbed pattern.
 5. Load-bearing metal plates adhered to pads.
- C. Double-Deflection, Elastomeric Isolation Mounts M1:
1. Mounting Plates:
 - a. Top Plate: Encapsulated steel load transfer top plates, factory drilled and threaded, or with threaded studs or bolts.
 - b. Baseplate: Encapsulated steel bottom plates with holes provided for anchoring to support structure.
 2. Elastomeric Material: Molded, oil-resistant rubber, neoprene, or other elastomeric material.
- D. Restrained Elastomeric Isolation Mounts M2:
1. Description: All-directional isolator with seismic restraints containing two separate and opposing elastomeric elements that prevent central threaded element and attachment hardware from contacting the housing during normal operation.
 - a. Housing: Cast-ductile iron or welded steel.
 - b. Elastomeric Material: Molded, oil-resistant rubber, neoprene, or other elastomeric material.
- E. Spring Isolators S1: Freestanding, laterally stable, open-spring isolators.
1. Outside Spring Diameter: Not less than 80 percent of the compressed height of the spring at rated load.
 2. Minimum Additional Travel: 50 percent of the required deflection at rated load.

3. Lateral Stiffness: More than 80 percent of rated vertical stiffness.
 4. Overload Capacity: Support 200 percent of rated load, fully compressed, without deformation or failure.
 5. Baseplates: Factory drilled for bolting to structure and bonded to 1/4-inch-thick, rubber isolator pad attached to baseplate underside. Baseplates shall limit floor load to 500 psig.
 6. Top Plate and Adjustment Bolt: Threaded top plate with adjustment bolt and cap screw to fasten and level equipment.
- F. Restrained Spring Isolators S2: Freestanding, steel, open-spring isolators with seismic or limit-stop restraint.
1. Housing: Steel with resilient vertical-limit stops to prevent spring extension due to weight being removed; factory-drilled baseplate bonded to 1/4-inch-thick, neoprene or rubber isolator pad attached to baseplate underside; and adjustable equipment mounting and leveling bolt that acts as blocking during installation. Baseplates shall limit floor load to 500 psig.
 2. Restraint: Seismic or limit stop as required for equipment and authorities having jurisdiction.
 3. Outside Spring Diameter: Not less than 80 percent of the compressed height of the spring at rated load.
 4. Minimum Additional Travel: 50 percent of the required deflection at rated load.
 5. Lateral Stiffness: More than 80 percent of rated vertical stiffness.
 6. Overload Capacity: Support 200 percent of rated load, fully compressed, without deformation or failure.
- G. Housed Restrained Spring Isolators S3: Freestanding, Steel, Open-Spring Isolators with Vertical-Limit Stop Restraint in Two-Part Telescoping Housing:
1. Two-Part Telescoping Housing: A steel top and bottom frame separated by an elastomeric material and enclosing the spring isolators. Housings are equipped with adjustable snubbers to limit vertical movement.
 - a. Drilled base housing for bolting to structure with an elastomeric isolator pad attached to the underside. Bases shall limit floor load to 500 psig.
 - b. Threaded top housing with adjustment bolt and cap screw to fasten and level equipment.
 2. Outside Spring Diameter: Not less than 80 percent of the compressed height of the spring at rated load.
 3. Minimum Additional Travel: 50 percent of the required deflection at rated load.
 4. Lateral Stiffness: More than 80 percent of rated vertical stiffness.
 5. Overload Capacity: Support 200 percent of rated load, fully compressed, without deformation or failure.
 6. Elastomeric pad: For high frequency absorption at the base of the spring.
- H. Elastomeric Hangers H1:
1. Description: Elastomeric Mount in a Steel Frame with Upper and Lower Steel Hanger Rods
 - a. Frame: Steel, fabricated with a connection for an upper threaded hanger rod and an opening on the underside to allow for a maximum of 30 degrees of angular lower hanger-rod misalignment without binding or reducing isolation efficiency.
 - b. Dampening Element: Molded, oil-resistant rubber, neoprene, or other elastomeric material with a projecting bushing for the underside opening preventing steel to steel contact.

- I. Spring Hangers H2: Combination coil-spring and elastomeric-insert hanger with spring and insert in compression.
 - 1. Description: Combination Coil-Spring and Elastomeric-Insert Hanger with spring and Insert in Compression.
 - a. Frame: Steel, fabricated for connection to threaded hanger rods and to allow for a maximum of 30 degrees of angular hanger-rod misalignment without binding or reducing isolation efficiency.
 - b. Outside Spring Diameter: Not less than 80 percent of the compressed height of the spring at rated load.
 - c. Minimum Additional Travel: 50 percent of the required deflection at rated load.
 - d. Lateral Stiffness: More than 80 percent of rated vertical stiffness.
 - e. Overload Capacity: Support 200 percent of rated load, fully compressed, without deformation or failure.
 - f. Elastomeric Element: Molded, oil-resistant rubber or neoprene. Steel-washer-reinforced cup to support spring and bushing projecting through bottom of frame.
 - g. Self-centering hanger rod cap to ensure concentricity between hanger rod and support spring coil.
- J. Spring Hangers with Vertical-Limit Stop H3: Combination coil-spring and elastomeric-insert hanger with spring and insert in compression.
 - 1. Description: Combination Coil-Spring and Elastomeric-Insert Hanger with spring and insert in Compression and vertical limit stop.
 - a. Frame: Steel, fabricated for connection to threaded hanger rods and to allow for a maximum of 30 degrees of angular hanger-rod misalignment without binding or reducing isolation efficiency.
 - b. Outside Spring Diameter: Not less than 80 percent of the compressed height of the spring at rated load.
 - c. Minimum Additional Travel: 50 percent of the required deflection at rated load.
 - d. Lateral Stiffness: More than 80 percent of rated vertical stiffness.
 - e. Overload Capacity: Support 200 percent of rated load, fully compressed, without deformation or failure.
 - f. Elastomeric Element: Molded, oil-resistant rubber or neoprene. Steel-washer-reinforced cup to support spring and bushing projecting through bottom of frame.
 - g. Adjustable Vertical Stop: Steel washer with neoprene washer "up-stop" on lower threaded rod.
 - h. Self-centering hanger rod cap to ensure concentricity between hanger rod and support spring coil.
- K. Pipe Riser Resilient Support R1:
 - 1. Description: All-directional, acoustical pipe anchor consisting of 2 steel tubes separated by a minimum of 1/2-inch-thick neoprene.
 - a. Vertical-Limit Stops: Steel and neoprene vertical-limit stops arranged to prevent vertical travel in both directions.
 - b. Maximum Load Per Support: 500 psig on isolation material providing equal isolation in all directions.
- L. Resilient Pipe Guides R2:
 - 1. Description: Telescopic arrangement of two steel tubes or post and sleeve arrangement separated by a minimum 1/2-inch-thick neoprene.

- a. Factory-Set Height Guide with Shear Pin: Shear pin shall be removable and reinsertable to allow for selection of pipe movement. Guides shall be capable of motion to meet location requirements.

M. Horizontal Thrust Restraints T1: Modified specification S2 isolator.

1. Horizontal thrust restraints shall consist of a modified specification S2 spring mounting. Restraint springs shall have the same deflection as the isolator springs.
2. The assembly shall be preset at the factory and fine tuned in the field to allow for a maximum of 1/4" movement from stop to maximum thrust.
3. The assemblies shall be furnished with rod and angle brackets for attachment to both the equipment and duct work or the equipment and the structure.
4. Restraints shall be attached at the center line of thrust and symmetrically on both sides of the unit.

2.2 RESTRAINED VIBRATION ISOLATION ROOF-CURB RAILS

A. Manufacturers: Subject to compliance with requirements, provide products by one of the following:

1. Amber/Booth Company, Inc.
2. CalDyn (California Dynamics Corporation).
3. ISAT (International Seismic Application Technology).
4. Kinetics Noise Control.
5. Mason Industries.
6. Vibro-Acoustics
7. VMC (Vibration Mountings & Controls, Inc.)

B. Restrained Vibration Isolation Roof-Curb Rails: RC1:

C. Description: Factory-assembled, fully enclosed, insulated, air- and watertight curb rail designed to resiliently support equipment and to withstand seismic and wind forces.

D. Upper Frame: The upper frame shall provide continuous support for equipment and shall be captive to resiliently resist seismic forces.

E. Lower Support Assembly: The lower support assembly shall be a formed sheet-metal section containing adjustable and removable steel springs that support upper frame. Lower support assembly shall have a means for attaching to building structure and a wood nailer for attaching roof materials, and shall be insulated with a minimum of 2 inches of rigid, glass-fiber insulation on inside of assembly.

F. Spring Isolators: Adjustable, restrained spring isolators shall be mounted on 1/4-inch-thick, elastomeric vibration isolation pads and shall have access ports, for level adjustment, with removable waterproof covers at all isolator locations. Isolators shall be located so they are accessible for adjustment at any time during the life of the installation without interfering with the integrity of the roof.

1. Restrained Spring Isolators: Freestanding, steel, open-spring isolators with seismic and wind restraint.
 - a. Housing: Steel with resilient vertical-limit stops and adjustable equipment mounting and leveling bolt.
 - b. Outside Spring Diameter: Not less than 80 percent of the compressed height of the spring at rated load.
 - c. Minimum Additional Travel: 50 percent of the required deflection at rated load.
 - d. Lateral Stiffness: More than 80 percent of rated vertical stiffness.

- e. Overload Capacity: Support 200 percent of rated load, fully compressed, without deformation or failure.
- G. Snubber Bushings: All-directional, elastomeric snubber bushings at least 1/4 inch-thick.
- H. Water Seal: Galvanized sheet metal with EPDM seals at corners, attached to upper support frame, extending down past wood nailer of lower support assembly, and counter flashed over roof materials.

2.3 VIBRATION ISOLATION EQUIPMENT BASES

- A. Manufacturers: Subject to compliance with requirements, provide products by one of the following:
 - 1. Amber/Booth Company, Inc.
 - 2. CalDyn (California Dynamics Corporation).
 - 3. ISAT (International Seismic Application Technology).
 - 4. Kinetics Noise Control.
 - 5. Mason Industries.
 - 6. Vibro-Acoustics
 - 7. VMC (Vibration Mountings & Controls, Inc.)
- B. Steel Bases and Rails SB1: Factory-fabricated, welded, structural-steel bases and rails.
 - 1. Design Requirements: Lowest possible mounting height with not less than 1-inch clearance above the floor. Include equipment anchor bolts and auxiliary motor slide bases or rails.
 - a. Include supports for suction and discharge elbows for pumps.
 - 2. Structural Steel: Steel shapes, plates, and bars complying with ASTM A 36/A 36M. Bases shall have shape to accommodate supported equipment.
 - 3. Support Brackets: Factory-welded steel brackets on frame for outrigger isolation mountings and to provide for anchor bolts and equipment support.
- C. Inertia Base IB1: Factory-fabricated, welded, structural-steel bases and rails ready for placement of cast-in-place concrete.
 - 1. Design Requirements: Lowest possible mounting height with not less than 2-inch clearance above the floor. Include equipment anchor bolts and auxiliary motor slide bases or rails.
 - a. Include supports for suction and discharge elbows for pumps.
 - 2. Structural Steel: Steel shapes, plates, and bars complying with ASTM A 36/A 36M. Bases shall have shape to accommodate supported equipment.
 - 3. Support Brackets: Factory-welded steel brackets on frame for outrigger isolation mountings and to provide for anchor bolts and equipment support.
 - 4. Fabrication: Fabricate steel templates to hold equipment anchor-bolt sleeves and anchors in place during placement of concrete. Obtain anchor-bolt templates from supported equipment manufacturer.

2.4 SEISMIC-RESTRAINT DEVICES

- A. Manufacturers: Subject to compliance with requirements, provide products by one of the following:

1. Amber/Booth Company, Inc.
 2. CalDyn (California Dynamics Corporation).
 3. ISAT (International Seismic Application Technology).
 4. Kinetics Noise Control.
 5. Mason Industries.
 6. Vibro-Acoustics
 7. VMC (Vibration Mountings & Controls, Inc.)
- B. General Requirements for Restraint Components: Rated strengths, features, and applications shall be as defined in reports by an evaluation service member of ICC-ES.
1. Structural Safety Factor: Allowable strength in tension, shear, and pullout force of components shall be at least four times the maximum seismic forces to which they will be subjected.
- C. Snubbers: Factory fabricated using welded structural-steel shapes and plates, anchor bolts, and replaceable resilient isolation washers and bushings.
1. Anchor bolts for attaching to concrete shall be seismic-rated, drill-in, and stud-wedge or female-wedge type.
 2. Resilient Isolation Washers and Bushings: Oil- and water-resistant neoprene.
 3. Maximum 1/4-inch air gap, and minimum 1/4-inch-thick resilient cushion.
- D. Channel Support System: MFMA-4, shop- or field-fabricated support assembly made of slotted steel channels with accessories for attachment to braced component at one end and to building structure at the other end and other matching components and with corrosion-resistant coating; and rated in tension, compression, and torsion forces.
- E. Restraint Cables: ASTM A 603 galvanized or ASTM A 492 stainless-steel cables with end connections made of steel assemblies with thimbles, brackets, swivel, and bolts designed for restraining cable service; and with a minimum of two clamping bolts for cable engagement. Cables located in exterior or other wet locations such as wash-down areas shall be stainless steel.
- F. Hanger Rod Stiffener: Steel tube or steel slotted-support-system sleeve with internally bolted connections or reinforcing steel angle clamped to hanger rod.
- G. Hinged and Swivel Brace Attachments: Multifunctional steel connectors for attaching hangers to rigid channel bracings and restraint cables.
- H. Bushings for Floor-Mounted Equipment Anchor Bolts: Neoprene bushings designed for rigid equipment mountings, and matched to type and size of anchor bolts and studs.
- I. Bushing Assemblies for Wall-Mounted Equipment Anchorage: Assemblies of neoprene elements and steel sleeves designed for rigid equipment mountings, and matched to type and size of attachment devices used.
- J. Resilient Isolation Washers and Bushings: One-piece, molded, oil- and water-resistant neoprene, with a flat washer face.
- K. Mechanical Anchor Bolts: Drilled-in and stud-wedge or female-wedge type in zinc-coated steel for interior applications and stainless steel for exterior applications. Select anchor bolts with strength required for anchor and as tested according to ASTM E 488. Minimum length of eight times diameter.
- L. Adhesive Anchor Bolts: Drilled-in and capsule anchor system containing polyvinyl or urethane methacrylate-based resin and accelerator, or injected polymer or hybrid mortar adhesive. Provide anchor bolts and hardware with zinc-coated steel for interior applications and stainless

steel for exterior applications. Select anchor bolts with strength required for anchor and as tested according to ASTM E 488.

- M. All post installed anchors utilized in the seismic design must be qualified for use in cracked concrete and approved for use with seismic loads.
- N. Expansion anchors shall not be used for anchorage of equipment with motors rated over 10 HP with the exception of undercut expansion anchors. Spring or internally isolated equipment are exempt from this requirement.
- O. All beam clamps utilized for vertical support must also incorporate retention straps.
- P. All seismic brace arm anchorages to include concrete anchors, beam clamps, truss connections, etc., must be approved for use with seismic loads.

2.5 FACTORY FINISHES

- A. Finish: Manufacturer's standard paint applied to factory-assembled and tested equipment before shipping.
 - 1. Powder coating on springs and housings.
 - 2. All hardware shall be galvanized. Hot-dip galvanize metal components for exterior use.
 - 3. Baked enamel or powder coat for metal components on isolators for interior use.
 - 4. Color-code or otherwise mark vibration isolation and seismic control devices to indicate capacity range.

PART 3 - EXECUTION

3.1 EXAMINATION

- A. Examine areas and equipment to receive vibration isolation and seismic control devices for compliance with requirements for installation tolerances and other conditions affecting performance of the Work.
- B. Examine roughing-in of reinforcement and cast-in-place anchors to verify actual locations before installation.
- C. Proceed with installation only after unsatisfactory conditions have been corrected.

3.2 COORDINATION

- A. Coordinate the location of embedded connection hardware with supported equipment attachment and mounting points and with requirements for concrete reinforcement and formwork specified in Division 03 Section "Cast-in-Place Concrete."
- B. Coordinate size, shape, reinforcement and attachment of all housekeeping pads supporting vibration/seismically rated equipment. Concrete shall have a minimum compressive strength of 4,000 psi or as specified by the project engineer. Coordinate size, thickness, doweling, and reinforcing of concrete equipment housekeeping pads and piers with vibration isolation and seismic restraint device manufacturer to ensure adequate space, embedment and prevent edge breakout failures. Pads and piers must be adequately doweled in to structural slab.
- C. Housekeeping pads shall have adequate space to mount equipment and seismic restraint devices.

- D. Housekeeping Pads must be adequately reinforced and adequately sized for proper installation of equipment anchors and shall also be large enough and thick enough to ensure adequate edge distance and embedment depth for restraint anchor bolts to avoid housekeeping pad breakout failure. Refer seismic restraint manufacturer's written instructions.
- E. Coordinate with vibration/seismic restraint manufacturer and the structural engineer of record to locate and size structural supports underneath vibration/seismically restrained equipment (e.g. roof curbs, cooling towers and other similar equipment). Installation of all seismic restraint materials specified in this section shall be accomplished as per the manufacturer's written instructions. Adjust isolators and restraints after piping systems have been filled and equipment is at its operating weight, following the manufacturer's written instructions.

3.3 APPLICATIONS

- A. Multiple Pipe Supports: Secure pipes to trapeze member with clamps approved for application by an evaluation service member of ICC-ES and per the seismic restraint manufacturer's design.
- B. Hanger Rod Stiffeners: Install hanger rod stiffeners where indicated or scheduled on Drawings to receive them and where required to prevent buckling of hanger rods due to seismic forces.
- C. Strength of Support and Seismic-Restraint Assemblies: Where not indicated, select sizes of components so strength will be adequate to carry present and future static and seismic loads within specified loading limits.

3.4 VIBRATION-CONTROL DEVICE INSTALLATION

- A. Comply with requirements in Division 07 Section "Roof Accessories" for installation of roof curbs, equipment supports, and roof penetrations.
- B. Comply with requirements in Division 23 Section "Hydronic Piping" for piping flexible connections.
- C. Isolate all mechanical equipment 0.75 hp and over per the isolator and seismic restraint schedule and these specifications. Vibration isolators shall be selected in accordance with the equipment, pipe or duct weight distribution so as to produce reasonably uniform deflections
- D. All isolation materials and seismic restraints shall be of the same vendor and shall be selected and certified using published or factory certified data
- E. Installation of all vibration isolation materials, flexible connectors and supplemental equipment bases specified in this section shall be accomplished as per the manufacturer's written instructions with mountings adjusted to level equipment. Any variance or non-compliance with the manufacturer's instructions shall be reviewed and approved in writing by the manufacturer or corrected by the contractor in an approved manner.
- F. Installation of vibration isolators must not cause any change of position of equipment, piping or duct work resulting in stresses or misalignment.
- G. Locate isolation hangers as near to the overhead support structure as possible.
- H. No rigid connections between isolated components and the building structure shall be made that degrades the noise and vibration control system herein specified. "Building" includes, but is not limited to, slabs, beams, columns, studs and walls. "Components" includes, but is not limited to, mechanical equipment, piping and ducts.

- I. Coordinate work with other trades to avoid rigid contact with the building.
- J. Any conflicts with other trades which will result in rigid contact with equipment or piping due to inadequate space or other unforeseen conditions should be brought to the architects/engineers attention prior to installation. Corrective work necessitated by conflicts after installation shall be at the responsible contractor's expense.
- K. Bring to the architects/engineers attention any discrepancies between the specifications and the field conditions or changes required due to specific equipment selection, prior to installation. Corrective work necessitated by discrepancies after installation shall be at the responsible contractor's expense.
- L. Correct, at no additional cost, all installations which are deemed defective in workmanship and materials at the contractor's expense.
- M. Use horizontal thrust restraints T1 to protect Air handling equipment and centrifugal fans against excessive displacement which results from high air thrust when thrust forces exceed 10% of the equipment weight.
- N. Isolated equipment, duct and piping located on roofs must be attached to the structure. Supports (e.g., sleepers) that are not attached to the structure will not be acceptable.
- O. On completion of installation of all isolation materials and before startup of isolated equipment all debris shall be cleared from areas surrounding and from beneath all isolated equipment, leaving equipment free to move on the isolation supports.
- P. All floor mounted isolated equipment shall be protected with specification M1, M2, S1, S2 or S3 isolator.
- Q. Horizontal Pipe Isolation: All HVAC pumped water, pumped condensate, glycol, and refrigerant piping size 1-1/4" and larger within mechanical rooms shall be isolated. Outside equipment rooms this piping shall be isolated for the greater of 50' or 100 pipe diameters from rotating equipment. For the first three (3) support locations from externally isolated equipment provide specification H2 or H3 hangers or specification S1, S2 or S3 mounts with the same deflection as equipment isolators (max 2"). All other piping within the equipment rooms shall be isolated with the same specification isolators with a 3/4" minimum deflection. Steam piping size 1-1/4" and larger which is within an equipment room and connected to rotating equipment shall be isolated for three (3) support locations from the equipment. Provide specification H2 or H3 hangers, or specification S1 or S2 mounts with the same deflection as equipment isolators but a minimum of 3/4".
- R. Install full line size flexible pipe connectors at the inlet and outlet of each pump, cooling tower, condenser, chiller, coiling connections and where shown on the drawings. All connectors shall be suitable for use at the temperature, pressure, and service encountered at the point of installation and operation. End fitting connectors shall conform to the pipefitting schedule. Control rods or protective braid must be used to limit elongation to 3/8". Flexible connectors shall not be required for suspended in-line pumps.
- S. All plumbing pumped water, piping size 1-1/4" and larger within mechanical rooms shall be isolated the same as HVAC piping above. Isolators are not required for any plumbing pumped water, pumped condensate, and steam piping outside of mechanical rooms unless listed in the isolation schedule.
- T. Pipe Riser Isolation: The operating weight of all variable temperature vertical pipe risers 1-1/4" and larger, requiring isolation where specifically shown and detailed on riser drawings shall be fully supported by specification M1, M2 or R1 supports. S1, S2, S3, H2 or H3 steel spring deflection isolators with minimum 3/4-inch minimum shall be in those locations where added deflection is required due to pipe expansion and contraction. Spring deflection shall be a

minimum of 4 times the anticipated deflection change. Springs shall be selected to keep the riser in tension. Height saving brackets used with isolators having 2.5" deflection or greater shall be of the precompression type to limit exposed bolt length. Specification R1 riser supports shall be installed near the center point of the riser to anchor the riser when spring isolation is used. Specification R2 riser guides may be used in conjunction with spring isolators per design calculations. Pipe risers up through 16" shall be supported at intervals of every third floor of the building. Pipe risers 18" and over, every second floor. Wall sleeves for take-offs from riser shall be sized for insulation O.D. plus two times the anticipated movement to prevent binding. Horizontal take-offs and at upper and lower elbows shall be supported with spring isolators as required to accommodate anticipated movement. In addition to submittal data requirements previously outlined, riser diagrams and calculations shall be submitted for approval. Calculations must show anticipated expansion and contraction at each support point, initial and final loads on the building structure, and spring deflection changes. Submittal data shall include certification that the riser system has been examined for excessive stresses and that none will exist if installed per design proposed.

- U. Where riser pipes pass through cored holes, core diameters shall be a maximum of 2" larger than pipe O.D. including insulation. Cored holes must be packed with resilient material or firestop as provided by other sections of this specification or local codes. Where seismic restraint is required specification isolator S3 shall support risers and provide longitudinal restraint at floors where thermal expansion is minimal and will not bind isolator restraints.
- V. Duct Isolation: Isolate all duct work with a static pressure 2" W.C. and over in equipment rooms and to minimum of 50 feet from the fan or air handler. Use specification type H2 or H3 hangers or type S1 or S2 floor mounts.

3.5 SEISMIC-RESTRAINT DEVICE INSTALLATION

A. Equipment Restraints:

1. On projects with Seismic Site Class A or B, seismic design or restraint is not required.
2. On projects with Seismic Design Category C: Components with an importance factor of 1.0 do not require seismic design or restraint.
3. Install seismic snubbers on HVAC equipment mounted on vibration isolators. Locate snubbers as close as possible to vibration isolators and bolt to equipment base and supporting structure.
4. Install resilient bolt isolation washers on equipment anchor bolts where clearance between anchor and adjacent surface exceeds 0.125 inch.
5. Install seismic-restraint devices using methods approved by an evaluation service member of ICC-ES providing required submittals for component.
6. Suspended Equipment: All suspended equipment that meets any of the following conditions requires seismic restraints as specified by the supplier:
 - a. Rigidly attached to pipe or duct that is 75 lbs. and greater,
 - b. Items greater than 20 lbs and distribution systems weighing more than 5 lbs/lineal foot, with an importance factor of 1.0 hung independently or with flexible connections.
 - c. Possibility of consequential damage.
 - d. For importance factors greater than 1.0 all suspended equipment requires seismic restraint regardless of the above notes.
 - e. Wall mounted equipment weighing more than 20 lbs.
 - f. Exemptions:

- 1) Equipment weighing less than 20 lbs and distribution systems weighing less than 5 lbs/lineal foot, with an $I_p = 1.0$ and where flexible connections exist between the component and associated ductwork, piping or conduit.
7. Base Mounted Equipment: All base mounted equipment that meets any of the following conditions requires attachments and seismic restraints as specified by the supplier:
- a. Connections to or containing hazardous material,
 - b. With an overturning moment.
 - c. Weight greater than 400 lbs.
 - d. Mounted on a stand 4 ft. or more from the floor
 - e. Possibility of consequential damage.
 - f. For importance factors greater than 1.0 all base mounted items require seismic restraints regardless of the above notes.
 - g. For equipment with high center of gravity additional cable restraints shall be furnished, as required by isolation manufacturer, to limit forces and motion caused by rocking.
 - h. Exemptions:
 - 1) Floor or curb-mounted equipment weighing less than 400 lbs and not resiliently mounted, where the Importance Factor, $I_p = 1.0$, the components are mounted at 4 feet or less above a floor level, flexible connections between the components and associated duct work, piping and conduit are provided and there is no possibility of consequential damage.
8. Roof Mounted Equipment:
- a. To be installed on a structural frame, seismically rated roof curb, or structural curb frame mechanically connected to the structure. Items shall not be mounted onto sleepers or pads that are not mechanically and rigidly attached to the structure. Restraint must be adequate to resist both seismic and wind forces.
 - b. Roof curbs shall be installed directly to building structural steel or concrete roof deck and not to top of steel deck or roofing material.
 - c. Exemptions:
 - 1) Curb-mounted mushroom, exhaust and vent fans with curb area less than nine square feet are excluded.
9. Rigid Mounted Equipment:
- a. Anchor floor and wall mounted equipment to the structure as per the stamped seismic certifications / drawings.
 - b. For equipment with high center of gravity additional cable restraints shall be furnished, as required by isolation manufacturer, to limit forces and motion caused by rocking.
 - c. Suspended equipment shall be restrained using seismic cable restraints, or struts, and hanger rods as per the stamped seismic certifications / drawings.
10. Vibration Isolated Equipment:
- a. Seismic control shall not compromise the performance of noise control, vibration isolation or fire stopping systems.
 - b. Equipment supported by vibration-isolation hangers shall be detailed and installed with approximately a 1/8" gap between the isolation hangers and the structure. Isolators at restraint locations must be fitted with uplift limit stops.
- B. Install seismic snubbers on HVAC equipment mounted on vibration isolators. Locate snubbers as close as possible to vibration isolators and bolt to equipment base and supporting structure.

- C. Install resilient bolt isolation washers on equipment anchor bolts where clearance between anchor and adjacent surface exceeds 0.125 inch.
- D. Install seismic-restraint devices using methods approved by an evaluation service member of ICC-ES providing required submittals for component.
- E. Installation and adjustment of all seismic restraints specified in this section shall be accomplished as per the manufacturer's written instructions. Any deviation from the manufacturer's instructions shall be reviewed and approved by the manufacturer.
- F. Piping Restraints:
 - 1. Comply with requirements in MSS SP-127.
 - 4. Seismically restrain piping, with an $I_p = 1.0$, located in boiler rooms, mechanical equipment rooms and refrigeration equipment rooms that is $1\frac{1}{4}$ " I.D. and larger.
 - 5. Seismically restrain all other $I_p = 1.0$ piping $2\frac{1}{2}$ " diameter and larger.
 - 6. Seismically restrain all $I_p = 1.5$ piping larger than 1" diameter.
 - 7. Branch lines may not be used to brace main lines.
 - 8. Exemptions:
 - a. All high deformability pipe 3" or less in diameter suspended by individual hanger rods where $I_p = 1.0$.
 - b. High deformability pipe or conduit in Seismic Design Category C, 2" or less in diameter suspended by individual hanger rods where $I_p = 1.5$.
 - c. High deformability pipe in Seismic Design Category D, E or F, 1" or less in diameter suspended by individual hanger rods where $I_p = 1.5$.
 - d. All clevis supported pipe runs installed less than 12" from the top of the pipe to the underside of the support point and trapeze supported pipe suspended by hanger rods having a distance less than 12" in length from the underside of the pipe support to the support point of the structure.
 - e. Piping systems, including their supports, designed and constructed in accordance with ASME B31.
 - f. Piping systems, including their supports, designed and constructed in accordance with NFPA, provided they meet the force and displacement requirements of Section 13.3.1 and 13.3.2 (ASCE 7).
- G. Install flexible metal hose loops in piping which crosses building seismic joints, sized for the anticipated amount of movement.
- H. Install flexible piping connectors where adjacent sections or branches are supported by different structural elements, and where the connections terminate with connection to equipment that is anchored to a different structural element from the one supporting the connections as they approach equipment.
- I. Where pipe sizes reduce below dimensions required for seismic, the final restraint shall be installed at the transition location.
- J. Restraint Spacing For Piping: Sizes shown are maximum. Actual spacing determined by calculation.
 - 1. For non-ductile piping (e.g., cast iron, PVC) space transverse supports a maximum of 20' o.c., and longitudinal supports a maximum of 40' o.c.
 - 2. For piping with hazardous material inside (e.g., natural gas, medical gas) space Transverse supports a maximum of 20' o.c., and longitudinal supports a maximum of 40' o.c.
 - 3. For pipe risers, restrain the piping at floor penetrations using the same spacing requirements as above.
 - 4. For all other ductile piping see Table "A" below

- K. Seismic Restraint of Ductwork: Seismically restrain per specific code requirements, all ductwork listed below (unless otherwise indicated on the drawings), using seismic cable restraints: (Ductwork not meeting criteria listed below is to be "Exempt")
1. Restrain rectangular ductwork with cross sectional area of 6 square feet or larger. Duct with and an importance factor of 1.5 must be braced with no exceptions regardless of size or distance requirements.
 2. Restrain round ducts with diameters of 28" or larger. Duct with an importance factor of 1.5 must be braced with no exceptions regardless of size or distance requirements.
 3. Restrain flat oval ducts the same as rectangular ducts of the same nominal size.
 4. Duct must be reinforced at the restraint locations. Reinforcement shall consist of an additional angle on top of the ductwork that is attached to the support hanger rods. Ductwork is to be attached to both upper angle and lower trapeze. Additional reinforcing is not required if duct sections are mechanically fastened together with frame bolts and positively fastened to the duct support suspension system.
 5. A group of ducts may be combined in a larger frame so that the combined weights and dimensions of the ducts are less than or equal to the maximum weight and dimensions of the duct for which bracing details are selected.
 6. Walls, including gypsum board non-bearing partitions, which have ducts running through them, may replace a typical transverse brace. Provide channel framing around ducts and solid blocking between the duct and frame.
 7. If ducts are supported by angles, channels or struts, ducts shall be fastened to it at seismic brace locations in lieu of duct reinforcement.
 8. All ductwork weighing more than 17 lb/ft.
 9. Exemptions:
 - a. Duct runs supported at locations by two rods less than 12 inches in length from the structural support to the structural connection to the ductwork. This exemption does not apply to ducts with an importance factor of 1.5.
 10. See Table "A" below for restraint spacing.
- L. Exemptions do not apply for:
1. Life Safety or High Hazard Components
 - a. Including gas, fire protection, medical gas, fuel oil and compressed air needed for the continued operation of the facility or whose failure could impair the facility's continued operation, Occupancy Category IV, IBC-2018 as listed in Section 1.3 B regardless of governing code for HVAC, Plumbing, Electrical piping or equipment. (A partial list is illustrated.) High Hazard is additionally classified as any system handling flammable, combustible or toxic material. Typical systems not excluded are additionally listed below.
 2. Piping
 - a. Fuel oil, gasoline, natural gas, medical gas, steam, compressed air or any piping containing hazardous, flammable, combustible, toxic or corrosive materials. Fire protection standpipe, risers and mains. Fire Sprinkler Branch Lines must be end tied.
 3. Duct
 - a. Smoke evacuation duct or fresh air make up connected to emergency system, emergency generator exhaust, boiler breeching or as used by the fire department on manual override.
 4. Equipment

- a. Previously excluded non life safety duct mounted systems such as fans, variable air volume boxes, heat exchangers and humidifiers having a weight greater than 75 lbs require independent seismic bracing.

M. Spacing Chart For Suspended Components:

Table "A" Seismic Bracing (Maximum Allowable Spacing Shown- Actual Spacing to Be Determined by Calculation)			
Equipment	On Center Transverse	On Center Longitudinal	Change Of Direction
Duct			
All Sizes	30 Feet	60 Feet	4 Feet
Pipe Threaded, Welded, Soldered Or Grooved			
To 16"	40 Feet	80 Feet	4 Feet
18" – 28"	30 Feet	60 Feet	4 Feet
30" – 40"	20 Feet	60 Feet	4 Feet
42" & Larger	10 Feet	30 Feet	4 Feet

- N. Roof mounted duct is to be installed on sleepers or frames mechanically connected to the building structure. Roof anchors and seismic cables or frames shall be used to resist seismic and wind loading. Wind loading factors shall be determined by the registered design professional.
- O. Where duct sizes reduce below dimensions required for seismic restraint the final restraint shall be installed at the transition location.
- P. Install cables so they do not bend across edges of adjacent equipment or building structure.
- Q. Install bushing assemblies for anchor bolts for floor-mounted equipment, arranged to provide resilient media between anchor bolts and mounting hole in concrete base.
- R. Install bushing assemblies for mounting bolts for wall-mounted equipment, arranged to provide resilient media where equipment or equipment-mounting channels are attached to wall.
- S. Attachment to Structure: If specific attachment is not indicated, anchor bracing to structure at flanges of beams, at upper truss chords of bar joists, or at concrete members.
- T. Seismically Rated Beam Clamps are required where welding to or penetrations to steel beams are not approved.
- U. Drilled-in Anchors:
 1. Identify position of reinforcing steel and other embedded items prior to drilling holes for anchors. Do not damage existing reinforcing or embedded items during coring or drilling. Notify the structural engineer if reinforcing steel or other embedded items are encountered during drilling. Locate and avoid prestressed tendons, electrical and telecommunications conduit, and gas lines.
 2. Do not drill holes in concrete or masonry until concrete, mortar, or grout has achieved full design strength.
 3. Wedge Anchors: Protect threads from damage during anchor installation. Heavy-duty sleeve anchors shall be installed with sleeve fully engaged in the structural element to which anchor is to be fastened.
 4. Adhesive Anchors: Clean holes to remove loose material and drilling dust prior to installation of adhesive. Place adhesive in holes proceeding from the bottom of the hole and progressing toward the surface in such a manner as to avoid introduction of air pockets in the adhesive.

5. Set anchors to manufacturer's recommended torque, using a torque wrench.
6. Install zinc-coated steel anchors for interior and stainless-steel anchors for exterior applications.

3.6 ACCOMMODATION OF DIFFERENTIAL SEISMIC MOTION

- A. Install flexible connections in piping where they cross seismic joints, where adjacent sections or branches are supported by different structural elements, and where the connections terminate with connection to equipment that is anchored to a different structural element from the one supporting the connections as they approach equipment. Comply with requirements in Division 23 Section "Hydronic Piping" for piping flexible connections.

3.7 FIELD QUALITY CONTROL

- A. Testing Agency: Engage a qualified testing agency to perform tests and inspections.
- B. Perform tests and inspections.
 1. A representative of the vibration isolation system manufacturer shall review the project installation and provide documentation indicating conformance to vibration isolation design intent
- C. Remove and replace malfunctioning units and retest as specified above.
- D. Prepare test and inspection reports.
 1. The installing contractor shall submit a report upon request to the building architect and/or engineer, including the manufacturer's representative's final report, indicating that all seismic restraint material has been properly installed, or steps that are to be taken by the contractor to properly complete the seismic restraint work as per the specifications.

3.8 IDENTIFICATION

- A. Install identification tags at all seismic brace locations. Tags to include the following information:
 1. Specific seismic forces (g-force) the location was designed to resist.
 2. Maximum brace reaction at connection to structure.
 3. For single hung items, the maximum pipe/conduit size the brace location was designed to accommodate.
 4. For trapeze supported items, the maximum weight (lbs/lf) the brace location was designed to accommodate.
 5. For suspended equipment, the maximum unit operating weight (lbs) the brace location was designed to accommodate.
 6. Location identifier cross matched to that on plan set layout.
 7. Company name of installing contractor.

3.9 ADJUSTING

- A. Adjust isolators after piping system is at operating weight.
- B. Adjust leveling devices as required to distribute loading uniformly on isolators. Shim units as required where leveling devices cannot be used to distribute loading properly.

1. Adjust active height of spring isolators.
- C. Adjust limit stops on restrained spring isolators to mount equipment at normal operating height. After equipment installation is complete, adjust limit stops so they are out of contact during normal operation.
- D. Adjust restraints to permit free movement of equipment within normal mode of operation.

EQUIPMENT ISOLATION SCHEDULE									
LOCATION EQUIPMENT (1)	A' CRITICAL (35'-50' SPAN)			B' UPPER STORY (20'-35' SPAN)			C' GRADE		
	ISOLA TOR TYPE	MINIMU M DEFLE CTION (IN)	BASE TYPE	ISOLA TOR TYPE	MINIMU M DEFLE CTION (IN)	BASE TYPE	ISOLA TOR TYPE	MINIMU M DEFLE CTION (IN)	BASE TYPE
	AIR HANDLING UNITS FLOOR MOUNTED UP TO 15 HP 20 HP & OVER SUSPENDED UP TO 15 HP 20 HP & OVER HIGH PRESSURE FAN SECTIONS UP TO 30 HP 40 HP & OVER	S3 S3 H3 H3 S1 S1	1.5 2.5 1.75 2.5 2.5 3.5	 SB1 SB1 IB1 IB1	S3 S3 H3 H3 S3 S3	0.75 1.5 1 1.75 1.5 2.5	 IB1 IB1	S3 S3 H3 H3 S3 S3	0.75 0.75 1 1 0.75 1.5
CENTRIFUGAL FANS CL. I & II UP TO 54-112" W.D. UPT015HP 20-50 HP 60 HP & OVER CL. I & II 60" W.D. & OVER ALL CL. III FANS UPT015HP 20-50 H P 60 HP & OVER	S3 S1 S1 S1 S1 S1 S1	1.5 2.5 3.5 2.5 2.5 3.5	SB1 IB1 IB1 IB1 IB1 IB1	S3 S3 S1 S3 S1 S1	0.75 1.5 2.5 1.5 2.5 2.5	SB1 IB1 IB1 IB1 IB1 IB1	S3 S3 S3 S3 S3 S3	0.75 0.75 1.5 0.75 1.5 1.5	SB1 SB1 SB1 IB1 IB1 IB1
AXIAL FLOWFANS FLOOR MTD. UP TO 15 HP 20 HP & OVER SUSPENDED UP TO 15 HP 20 HP & OVER	S3 S1 H3 H3	1.5 3.5 1.75 2.5	SB1 IB1 SB1 SB1	S3 S3 H3 H3	0.75 1.5 1 1.75	 SB1	S3 S3 H3 H3	0.75 0.75 1 1.5	
VENT (UTILITY SETS) FLOOR MTD SUSPENDED	S3 H3	1.5 1.75	SB1 SB1	S3 H3	0.75 1		S3 H3	0.75 0.75	
CABINET FANS, FANS SECTIONS FLOOR MTD. UP TO 15 HP 20 HP & OVER SUSPENDED UP TO 15 HP	S3 S1 H3	1.5 2.5 1.75	 IB1	S3 S3 H3	0.75 1.5 1		S3 S3 H3	0.75 0.75 0.75	

20 HP & OVER	H3	2.5	SB1	H3	1.75		H3	1.75	
PUMPS									
FLOOR MTD. UP TO 15 HP	S3	0.75	IB1	S3	0.75	IB1	SRVD	0.4	IB1
7-112 HP & OVER	S3	1.5	IB1	S3	1.5	IB1	S3	0.75	IB1
SUSPENDED INLINE	H3	1.75		H3	1.75		H3	1	
REFRIGERATION UNITS									
RECIPROCATING COMPRESSORS	S1	2.5	IB1	S3	1.5	IB1	S3	0.75	IB1
RECIPROCATING COND. UNITS & CHILLERS	S1	2.5	IB1	S3	1.5		S3	0.75	
HERMETIC CENTRIFUGALS	S3	2.5		S3	1.5		P1	0.15	
OPEN CENTRIFUGALS	S1	2.5	IB1	S3	1.5	IB1	P1	0.15	
ABSORPTION MACHINES	S3	1.5		S3	0.75		P1	0.15	
AIR COMPRESSORS									
TANK TYPE (HORIZONTAL TANK)	S1	2.5	IB1	S3	1.5		S3	0.75	
TANK TYPE (VERTICAL TANK)	S1	2.5	IB1	S3	1.5	IB1	S3	0.75	
COOLING TOWERS & CLOSED CIRCUIT COOLERS									
UP TO 500 TONS	S3	2.5		S3	0.75		P1	0.15	
OVER 500 TONS	S3	4.5		S3	2.5		P1	0.15	
AIR COOLED CONDENSERS									
UP TO 50 TONS	S3	1.5		S3	0.75		P1	0.15	
OVER 50 TONS	S3	2.5		S3	1.5		P1	0.15	
ROOFTOP AIR CONDITIONING UNITS									
REQUIRING WEATHER SEAL									
UP TO 5000 CFM (12 TON)	S1	1.5	RC1	S1	0.75	RC1			
OVER 5000 CFM (12 TON)	S3	2.5	RC1	S3	1.5	RC1			
OTHER TYPES									
UP TO 25 TONS	S3	1.5		S3	1.5				
OVER 25 TONS	S3	2.5		S3	1.5				
BOILER (PACKAGE TYPE) ALL SIZES	S3	1.5		S3	0.75		P1	0.15	
ENGINE DRIVEN GENERATORS									
UP TO 60 HP	S1	2.5	IB1	S3	1.5	IB1	S3	0.75	
75 HP & OVER	S1	3.5	IB1	S3	2.5	IB1	S3	0.75	

NOTES:

1) Thrust restraints required on all high-pressure fan section, suspended axial-flow fans and on floor-mounted axial fans operating at 3.0" S.P. or greater.

END OF SECTION 23 0548

SECTION 23 0550

OPERATION AND MAINTENANCE OF HVAC SYSTEMS

PART 1 - GENERAL

1.1 RELATED DOCUMENTS

- A. All pertinent sections of Division 21, 22, & 23 Mechanical General Requirements, are part of the work of this Section. Division 01 is part of this and all other sections of these specifications.
 - 1. Division 23 Section "Testing, Adjusting, and Balancing for HVAC".
 - 2. Division 23 Section "Mechanical Requirements" for Training and Instructions to Owner's Representative.

1.2 SCOPE OF WORK

- A. Submission of Operating and Maintenance Manuals complete with Balancing reports. (Coordinate with Division 01).
- B. Coordination of work required for system commissioning.
- C. Provide a hard copy and an electronic copy on CD of the O and M manual fully searchable in PDF format.

1.3 SUBMITTALS

- A. Submit product data in accordance with Division 01 and Division 23 Section "Mechanical Requirements". Submit the following:
 - 1. Sample of O and M manual outline.

PART 2 - PRODUCTS

2.1 O & M MANUALS

- A. The operating and maintenance manuals shall be as follows:
 - 1. Binders shall be red buckram with easy-view metal for size 8-1/2 x 11-inch sheets, with capacity expandable from 2 inches to 3-1/2 inches as required for the project. Construction shall be rivet-through with library corners. No. 12 backbone and lining shall be the same material as the cover. The front cover and backbone shall be foil-stamped in white as follows: (coordinate with Division 01)

OPERATING AND MAINTENANCE
MANUAL
FOR THE

(INSERT PROJECT NAME)

(INSERT PROJECT COMPLETION YEAR)

VOLUME No. ()

VAN BOERUM & FRANK ASSOCIATES, INC.
MECHANICAL ENGINEER

(INSERT ARCHITECT)

Binders shall be a manufactured by:

We R Memory Makers
631 North 400 West
Salt Lake City, Utah 84103
801-539-5000

PART 3 - EXECUTION

3.1 OPERATING AND MAINTENANCE MANUALS:

- A. Work under this section shall be performed in concert with the contractor performing the system testing and balancing. Six (6) copies of the manuals shall be furnished to the Architect for distribution to the owner.
- B. The "Start-Up and Operation" section is one of the most important in the manual. Information in this section shall be complete and accurately written and shall be verified with the actual equipment on the job, such as switches, starters, relays, automatic controls, etc. A step-by-step start-up procedure shall be described.
- C. The manuals shall include air and water-balancing reports, system commissioning procedures, start-up tests and reports, equipment and system performance test reports, warranties, and certificates of training given to the owner's representatives.
- D. American Society of Mechanical Engineers (ASME) Stamp shall be required on all items required by code or specified to conform to the ASME Code, and certificates will be included in the O&M manuals.
- E. Form U-1, the manufacturers' data report for pressure vessels, is to be included in the operation and maintenance manuals. National Board Register (NBR) numbers shall be provided where required by code, and included in the manuals.
- F. Underwriters Laboratories (UL) or equivalent ETL labels shall be applied to manufactured equipment represented by a UL classification and/or listing. Included certification in the O&M manuals.

An index sheet typed on AICO Gold-Line indexes shall be provided in the front of the binder. The manual shall be include the following:

SYSTEM DESCRIPTIONS

START-UP PROCEDURE AND OPERATION OF SYSTEM

MAINTENANCE AND LUBRICATION TABLE

OPERATION AND MAINTENANCE BULLETINS

AUTOMATIC TEMPERATURE CONTROL DESCRIPTION OF OPERATION, INTERLOCK AND CONTROL DIAGRAMS, AND CONTROL PANELS.

AIR AND WATER SYSTEM BALANCING REPORTS

EQUIPMENT WARRANTIES AND TRAINING CERTIFICATES

SYSTEM COMMISSIONING REPORTS

EQUIPMENT START-UP CERTIFICATES

END OF SECTION 23 0550

THIS PAGE LEFT BLANK INTENTIONALLY

SECTION 23 0553

IDENTIFICATION FOR HVAC PIPING AND EQUIPMENT

PART 1 - GENERAL

1.1 RELATED DOCUMENTS

- A. Drawings and general provisions of the Contract, including General and Supplementary Conditions and Division 01 Specification Sections, apply to this Section.

1.2 SUMMARY

- A. Section Includes:
 - 1. Equipment labels.
 - 2. Danger, Warning and Caution signs and labels.
 - 3. Pipe labels.
 - 4. Duct labels.
 - 5. Stencils.
 - 6. Valve tags.
 - 7. Danger tags.
 - 8. Warning tags.
 - 9. Caution tags.
 - 10. Ceiling grid

1.3 ACTION SUBMITTALS

- A. Product Data: For each type of product indicated.
- B. Equipment Label Schedule: Include a listing of all equipment to be labeled with the proposed content for each label.
- C. Valve numbering scheme.
- D. Valve Schedules: For each piping system to include in maintenance manuals.

1.4 COORDINATION

- A. Coordinate installation of identifying devices with completion of covering and painting of surfaces where devices are to be applied.
- B. Coordinate installation of identifying devices with locations of access panels and doors.
- C. Install identifying devices before installing acoustical ceilings and similar concealment.

PART 2 - PRODUCTS

2.1 EQUIPMENT LABELS

A. Metal Labels for Equipment:

1. Material and Minimum Thickness, predrilled or stamped holes for attachment hardware:
 - a. Brass, 0.032-inch .
2. Minimum Label Size: Length and width vary for required label content, but not less than 2-1/2 by 3/4 inch.
3. Minimum Letter Size: 1/4 inch for name of units if viewing distance is less than 24 inches, 1/2 inch for viewing distances up to 72 inches, and proportionately larger lettering for greater viewing distances. Include secondary lettering two-thirds to three-fourths the size of principal lettering.
4. Fasteners: Stainless-steel;
 - a. Rivets or self-tapping screws
5. Adhesive: Contact-type permanent adhesive, compatible with label and with substrate.

B. Plastic Labels for Equipment:

1. Material and Thickness: Multilayer, multicolor, plastic labels for mechanical engraving, and having predrilled holes for attachment hardware, 1/16 inch thick.
2. Letter Color:
 - a. Black.
3. Background Color:
 - a. White.
4. Maximum Temperature: Able to withstand temperatures up to 160 deg F.
5. Minimum Label Size: Length and width vary for required label content, but not less than 2-1/2 by 3/4 inch.
6. Minimum Letter Size: 1/4 inch for name of units if viewing distance is less than 24 inches, 1/2 inch for viewing distances up to 72 inches, and proportionately larger lettering for greater viewing distances. Include secondary lettering two-thirds to three-fourths the size of principal lettering.
7. Fasteners: Stainless-steel;
 - a. Rivets or self-tapping screws
8. Adhesive: Contact-type permanent adhesive, compatible with label and with substrate.

C. Label Content: Include equipment's Drawing designation or unique equipment number, Drawing numbers where equipment is indicated (plans, details, and schedules), , plus the Specification Section number and title where equipment is specified. Label shall also include: capacity specified at designed operating conditions, actual capacity as balanced at site operating conditions, and area or zone served.

D. Equipment Label Schedule: For each item of equipment to be labeled, on 8-1/2-by-11-inch bond paper. Tabulate equipment identification number and identify Drawing numbers where equipment is indicated (plans, details, and schedules), plus the Specification Section number and title where equipment is specified. Equipment schedule shall be included in operation and maintenance data.

2.2 DANGER, WARNING AND CAUTION SIGNS AND LABELS

A. Material and Thickness: Multilayer, multicolor, plastic labels for mechanical engraving, having predrilled holes for attachment hardware; 1/16 inch thick.

B. Danger signs, colors:

1. Letter Color:
 - a. White.
 2. Background Color:
 - a. Red.
- C. Warning signs, colors:
1. Letter Color:
 - a. Black.
 2. Background Color:
 - a. Orange.
- D. Caution signs, colors:
1. Letter Color:
 - a. Black.
 2. Background Color:
 - a. Yellow.
- E. Maximum Temperature: Able to withstand temperatures up to 160 deg F.
- F. Minimum Label Size: Length and width vary for required label content, but not less than 2-1/2 by 3/4 inch.
- G. Minimum Letter Size: 1/4 inch for name of units if viewing distance is less than 24 inches, 1/2 inch for viewing distances up to 72 inches, and proportionately larger lettering for greater viewing distances. Include secondary lettering two-thirds to three-fourths the size of principal lettering.
- H. Fasteners: Stainless-steel;
1. Rivets or self-tapping screws
- I. Adhesive: Contact-type permanent adhesive, compatible with label and with substrate.
- J. Label Content: Include caution and warning information, plus emergency notification instructions.

2.3 PIPE LABELS

- A. General Requirements for Manufactured Pipe Labels: Preprinted, color-coded, with lettering indicating service, and showing flow direction.
- B. Pretensioned Pipe Labels: Precoiled, semirigid plastic formed to partially cover circumference of pipe and to attach to pipe without fasteners or adhesive.
- C. Self-Adhesive Pipe Labels: Printed plastic with contact-type, permanent-adhesive backing.
- D. Pipe Label Contents: Include identification of piping service using same designations or abbreviations as used on Drawings, pipe size, and an arrow indicating flow direction.
 1. Flow-Direction Arrows: Integral with piping system service lettering to accommodate both directions, or as separate unit on each pipe label to indicate flow direction.
 2. Lettering Size: At least 1-1/2 inches high.

2.4 DUCT LABELS

- A. Material and Thickness: Multilayer, multicolor, plastic labels for mechanical engraving, having predrilled holes for attachment hardware; 1/16 inch thick.

- B. Letter Color:
 - 1. As required per Duct Label Color Schedule
- C. Background Color:
 - 1. As required per Duct Label Color Schedule
- D. Maximum Temperature: Able to withstand temperatures up to 160 deg F.
- E. Minimum Label Size: Length and width vary for required label content, but not less than 2-1/2 by 3/4 inch.
- F. Minimum Letter Size: 1/4 inch for name of units if viewing distance is less than 24 inches, 1/2 inch for viewing distances up to 72 inches, and proportionately larger lettering for greater viewing distances. Include secondary lettering two-thirds to three-fourths the size of principal lettering.
- G. Fasteners: Stainless-steel;
 - 1. Rivets or self-tapping screws
- H. Adhesive: Contact-type permanent adhesive, compatible with label and with substrate.
- I. Duct Label Contents: Include identification of duct service using same designations or abbreviations as used on Drawings, duct size, and an arrow indicating flow direction.
 - 1. Flow-Direction Arrows: Integral with duct system service lettering to accommodate both directions, or as separate unit on each duct label to indicate flow direction.
 - 2. Lettering Size: At least 1-1/2 inches high.

2.5 STENCILS

- A. Stencils: Prepared with letter sizes according to ASME A13.1 for piping; minimum letter height of 1-1/4 inches for ducts; and minimum letter height of 3/4 inch for access panel and door labels, equipment labels, and similar operational instructions.
 - 1. Stencil Material:
 - a. Aluminum.
 - 2. Stencil Paint:
 - a. Exterior, gloss, alkyd enamel black unless otherwise indicated.
 - b. Paint may be in pressurized spray-can form.
 - 3. Identification Paint:
 - a. Exterior, alkyd enamel in colors according to ASME A13.1 unless otherwise indicated.

2.6 VALVE TAGS

- A. Valve Tags: Stamped or engraved with 1/4-inch letters for piping system abbreviation and 1/2-inch numbers.
 - 1. Tag Material, predrilled or stamped holes for attachment hardware, minimum thickness:
 - a. Brass, 0.051-inch
 - b. At least 1 inch by 3 inch
 - 2. Fasteners: Steel;
 - a. Wire-link or beaded chain; or S-hook
 - 3. Label Content
 - a. Plan Identification
 - b. Normal Position

- c. Duty
- d. Areas Served
- e. Valve Type

B. Valve Schedules:

1. For each piping system, on 8-1/2-by-11-inch bond paper, tabulate;
 - a. Valve number.
 - b. Piping system.
 - c. System abbreviation (as shown on valve tag).
 - d. Location of valve (room or space).
 - e. Normal-operating position (open, closed, or modulating).
 - f. Variations for identification.
 - g. Mark valves for emergency shutoff and similar special uses.
2. Valve-tag schedule:
 - a. Shall be included in operation and maintenance data.

2.7 VALVE TAGS FOR HEATING VALVES, STEAM VALVES, AND LOW PRESSURE SIDE HTW HEAT EXCHANGERS

A. Valve Tags: Stamped or engraved with 1/4-inch letters for piping system abbreviation and 1/2-inch numbers.

1. Tag Material, predrilled or stamped holes for attachment hardware, minimum thickness:
 - a. Brass, 0.051-inch
 - b. At least 1 inch by 3 inch
2. Fasteners: Steel;
 - a. Wire-link or beaded chain; or S-hook
3. Label Content
 - a. Plan Identification
 - b. Normal Position
 - c. Duty
 - d. Areas Served
 - e. Valve Type
 - f. Manufacturer
 - g. Size
 - h. Grade
 - i. Pressure-Temperature service rating

2.8 DANGER TAGS

A. Danger Tags: Preprinted or partially preprinted, accident-prevention tags, of plasticized card stock with matte finish suitable for writing.

1. Size:
 - a. 3 by 5-1/4 inches minimum
2. Fasteners:
 - a. Brass grommet and wire.
3. Nomenclature: Large-size primary caption such as "DANGER," and "DO NOT OPERATE."
4. Color: Red background with white lettering.

2.9 WARNING TAGS

- A. Warning Tags: Preprinted or partially preprinted, accident-prevention tags, of plasticized card stock with matte finish suitable for writing.
 - 1. Size:
 - a. 3 by 5-1/4 inches minimum
 - 2. Fasteners:
 - a. Brass grommet and wire.
 - 3. Nomenclature: Large-size primary caption such as "WARNING" and "DO NOT OPERATE."
 - 4. Color: Yellow background with black lettering.

2.10 CAUTION TAGS

- A. Caution Tags: Preprinted or partially preprinted, accident-prevention tags, of plasticized card stock with matte finish suitable for writing.
 - 1. Size:
 - a. 3 by 5-1/4 inches minimum
 - 2. Fasteners:
 - a. Brass grommet and wire.
 - 3. Nomenclature: Large-size primary caption such as "CAUTION," and "DO NOT OPERATE."
 - 4. Color: Orange background with black lettering.

2.11 CEILING GRID

- A. Provide red lettering on the ceiling tile grid of the locations of all fire dampers, smoke dampers and fire/smoke dampers. Size of lettering and verbiage is to conform to IBC and NFPA standards.
- B. Provide valve identification for all HVAC valves located above the ceiling on the ceiling grid below the valve.
- C. Provide VAV box identification for all VAV boxes located above the ceiling on the ceiling grid below the VAV box.

PART 3 - EXECUTION

3.1 PREPARATION

- A. Clean piping and equipment surfaces of substances that could impair bond of identification devices, including dirt, oil, grease, release agents, and incompatible primers, paints, and encapsulants.

3.2 EQUIPMENT LABEL INSTALLATION

- A. Install or permanently fasten labels on each major item of mechanical equipment.
- B. Locate equipment labels where accessible and visible.

3.3 PIPE LABEL INSTALLATION

- A. Piping Color-Coding: Painting of piping as specified in Division 09 Section “Exterior Painting” & “Interior Painting”.
- B. Stenciled Pipe Label Option:
1. Stenciled labels may be provided instead of manufactured pipe labels, at Installer’s option.
 2. Install stenciled pipe labels with painted, color-coded bands or rectangles on each piping system.
 - a. Identification Paint: Use for contrasting background.
 - b. Stencil Paint: Use for pipe marking.
- C. Locate pipe labels where piping is exposed or above accessible ceilings in finished spaces; machine rooms; accessible maintenance spaces such as shafts, tunnels, and plenums; and exterior exposed locations as follows:
1. Near each valve and control device.
 2. Near each branch connection, excluding short takeoffs for fixtures and terminal units. Where flow pattern is not obvious, mark each pipe at branch.
 3. Near penetrations through walls, floors, ceilings, and inaccessible enclosures.
 4. At access doors, manholes, and similar access points that permit view of concealed piping.
 5. Near major equipment items and other points of origination and termination.
 6. Spaced at maximum intervals of 50 feet along each run. Reduce intervals to 25 feet in areas of congested piping and equipment.
 7. On piping above removable acoustical ceilings. Omit intermediately spaced labels.
- D. Pipe Label Color Schedule:

MEDIUM IN PIPE	BACKGROUND COLOR	IDENTIFYING LETTERING	LETTERING COLOR
COMPRESSED GAS			
Hydrogen	Brown	Hydrogen	Black
Natural Gas	Brown	Natural Gas	Yellow
Oxygen	Brown	Oxygen	Black
VACUUM			
Vacuum	Silver	Vacuum	Black
WATER **NOTE: DIRECTIONAL ARROWS ARE REQUIRED ON HTW PIPING.			
Boiler Blow-Off	Yellow	Blow-Off Water	Black
Chilled Water Supply	Blue	Chilled Water Supply	White
Chilled Water Return	Blue	Chilled Water Return	White
Condenser Water Supply	Blue	Cooling Water Supply	White
Condenser Water Return	Blue	Cooling Water Return	Black
Condensate Return	Orange	Condensate Return	Black
Cold Water (Potable)	Green	Domestic Cold Water	White
Non Potable	Green	Unsafe Water	Black
Domestic Hot Water (Potable)	Green	Domestic Hot Water	White
Domestic Hot	Green	Domestic Hot	White

Water Return		Water Return	
Fire Protection Water	Red	Fire Protection	White
Glycol Solution	Purple	Glycol Solution	White
Secondary Heating Water Supply	Brown	Heating Water Supply	White
Secondary Heating Water Return	Brown	Heating Water Return	White
Reverse Osmosis	Green	Rev. Osmosis Water	White
Softened	Green	Softened Water	Black
Roof Drain	Green	Roof Drain	White
System Make-Up	Green	Make-Up Water	White
Treated Water	Green	Treated Water	Black
WASTE			
Building Waste	(unpainted) or Black	Waste	White
ALL EQUIPMENT OR PIPING LOCATED OUTSIDE BUILDINGS			
All Equipment or Piping Located Outside Buildings	Brown	---	---

3.4 DUCT LABEL INSTALLATION

- A. Install plastic-laminated duct labels with permanent adhesive on air ducts in the following color codes:
1. Blue : For cold-air supply ducts.
 2. Yellow : For hot-air supply ducts.
 3. Green : For exhaust-, outside-, relief-, return-, and mixed-air ducts.
 4. ASME A13.1 Colors and Designs: For hazardous material exhaust.
- B. Locate labels near points where ducts enter into concealed spaces and at maximum intervals of 50 feet in each space where ducts are exposed or concealed by removable ceiling system.

3.5 VALVE-TAG INSTALLATION (See Drawing Schedules.)

- A. Install tags on valves and control devices in piping systems, except check valves; valves within factory-fabricated equipment units; shutoff valves; faucets; convenience and lawn-watering hose connections; and HVAC terminal devices and similar roughing-in connections of end-use fixtures and units. List tagged valves in a valve schedule.

3.6 WARNING-TAG INSTALLATION

- A. Write required message on, and attach warning tags to, equipment and other items where required.

3.7 ELECTRICAL SWITCHES AND STARTERS FOR MECHANICAL EQUIPMENT

- A. Label all electrical switches and starters identifying equipment served.

END OF SECTION 23 0553

SECTION 23 0593

TESTING, ADJUSTING, AND BALANCING FOR HVAC

PART 1 - GENERAL

1.1 RELATED DOCUMENTS

- A. Drawings and general provisions of the Contract, including General and Supplementary Conditions and Division 01 Specification Sections, apply to this Section.

1.2 SUMMARY

- A. Section Includes:
 - 1. Balancing Air Systems:
 - a. Constant-volume air systems.
 - b. Variable-air-volume systems.
 - 2. Balancing Hydronic Piping Systems:
 - a. Constant-flow hydronic systems.
 - b. Variable-flow hydronic systems.
 - c. Primary-secondary hydronic systems.
 - 3. Balancing Steam Systems.
 - 4. Various HVAC Equipment.
 - a. Heat Exchangers.
 - b. Motors.
 - c. Chillers.
 - d. Cooling Towers.
 - e. Condensing Units.
 - f. Boilers.
 - g. Heat Transfer Coils.
 - 5. Domestic Heater Systems.

1.3 DEFINITIONS

- A. AABC: Associated Air Balance Council.
- B. NEBB: National Environmental Balancing Bureau.
- C. TAB: Testing, adjusting, and balancing.
- D. TABB: Testing, Adjusting, and Balancing Bureau.
- E. TAB Specialist: An entity engaged to perform TAB Work.

1.4 ACTION SUBMITTALS

A. LEED Submittals:

1. Air-Balance Report for Prerequisite IEQ 1: Documentation of work performed for ASHRAE 62.1, Section 7.2.2 - "Air Balancing."
2. TAB Report for Prerequisite EA 2: Documentation of work performed for ASHRAE/IESNA 90.1, Section 6.7.2.3 - "System Balancing."

1.5 INFORMATIONAL SUBMITTALS

A. Qualification Data: Within the following number of days of the Contractor's Notice to Proceed, submit documentation that the TAB contractor and this Project's TAB team members meet the qualifications specified in "Quality Assurance" Article;

1. 30 days.

B. Certified TAB reports.

C. Instrument calibration reports, to include the following:

1. Instrument type and make.
2. Serial number.
3. Application.
4. Dates of use.
5. Dates of calibration.

1.6 QUALITY ASSURANCE

A. TAB Contractor Qualifications: Engage a TAB entity certified by AABC or NEBB.

1. TAB Field Supervisor: Employee of the TAB contractor and certified by AABC or NEBB and shall be the same as the TAB Contractor.
2. TAB Technician: Employee of the TAB contractor and who is certified by AABC or NEBB as a TAB technician and shall be the same as the TAB Contractor.

B. Certify TAB field data reports and perform the following:

1. Review field data reports to validate accuracy of data and to prepare certified TAB reports.
2. Certify that the TAB team complied with the approved TAB plan and the procedures specified and referenced in this Specification.

C. TAB Report Forms: Use standard TAB contractor's forms approved by:

1. Architect.

D. Instrumentation Type, Quantity, Accuracy, and Calibration: As described in ASHRAE 111, Section 5, "Instrumentation."

E. ASHRAE Compliance: Applicable requirements in ASHRAE 62.1, Section 7.2.2 - "Air Balancing."

F. ASHRAE/IESNA Compliance: Applicable requirements in ASHRAE/IESNA 90.1, Section 6.7.2.3 - "System Balancing."

1.7 PROJECT CONDITIONS

- A. Full Owner Occupancy: Owner will occupy the site and existing building during entire TAB period. Cooperate with Owner during TAB operations to minimize conflicts with Owner's operations.

1.8 COORDINATION

- A. Notice: Provide seven days' advance notice for each test. Include scheduled test dates and times.
- B. Perform TAB after leakage and pressure tests on the following distribution systems have been satisfactorily completed:
 - 1. Air and water.

PART 2 - PRODUCTS (Not Applicable)

PART 3 - EXECUTION

3.1 TAB SPECIALISTS

- A. Subject to compliance with requirements, engage one of the following:
 - 1. BTC Service.
 - 2. Certified Test & Balance.
 - 3. RS Analysis.

3.2 EXAMINATION

- A. Examine the Contract Documents to become familiar with Project requirements and to discover conditions in systems' designs that may preclude proper TAB of systems and equipment.
- B. Examine systems for installed balancing devices, such as test ports, gage cocks, thermometer wells, flow-control devices, balancing valves and fittings, and manual volume dampers. Verify that locations of these balancing devices are accessible.
- C. Examine the approved submittals for HVAC systems and equipment.
- D. Examine design data including HVAC system descriptions, statements of design assumptions for environmental conditions and systems' output, and statements of philosophies and assumptions about HVAC system and equipment controls.
- E. Examine:
 - 1. Ceiling plenums and underfloor air plenums used for supply, return, or relief air to verify that they meet the leakage class of connected ducts as specified in:
 - a. Division 23 Section "Metal Ducts"
 - 2. Verify ceiling plenums and underfloor air plenums used for supply, return or relief air are properly separated from adjacent areas.
 - 3. Verify that penetrations in plenum walls are sealed and fire-stopped if required.
- F. Examine equipment performance data including fan and pump curves.

1. Relate performance data to Project conditions and requirements, including system effects that can create undesired or unpredicted conditions that cause reduced capacities in all or part of a system.
 2. Calculate system-effect factors to reduce performance ratings of HVAC equipment when installed under conditions different from the conditions used to rate equipment performance. To calculate system effects for air systems, use tables and charts found in AMCA 201, "Fans and Systems," or in SMACNA's "HVAC Systems - Duct Design." Compare results with the design data and installed conditions.
- G. Examine system and equipment installations and verify that field quality-control testing, cleaning, and adjusting specified in individual Sections have been performed.
- H. Examine test reports specified in individual system and equipment Sections.
- I. Examine HVAC equipment and filters and verify that bearings are greased, belts are aligned and tight, and equipment with functioning controls is ready for operation.
- J. Examine terminal units, such as variable-air-volume boxes, and verify that they are accessible and their controls are connected and functioning.
- K. Examine strainers. Verify that startup screens are replaced by permanent screens with indicated perforations.
- L. Examine three-way valves for proper installation for their intended function of diverting or mixing fluid flows.
- M. Examine heat-transfer coils for correct piping connections and for clean and straight fins.
- N. Examine system pumps to ensure absence of entrained air in the suction piping.
- O. Examine operating safety interlocks and controls on HVAC equipment.
- P. Report deficiencies discovered before and during performance of TAB procedures. Observe and record system reactions to changes in conditions. Record default set points if different from indicated values.

3.3 PREPARATION

- A. Prepare a TAB plan that includes strategies and step-by-step procedures.
- B. Complete system-readiness checks and prepare reports. Verify the following:
1. Permanent electrical-power wiring is complete.
 2. Hydronic systems are filled, clean, and free of air.
 3. Automatic temperature-control systems are operational.
 4. Equipment and duct access doors are securely closed.
 5. Balance, smoke, and fire dampers are open.
 6. Isolating and balancing valves are open and control valves are operational.
 7. Ceilings are installed in critical areas where air-pattern adjustments are required and access to balancing devices is provided.
 8. Windows and doors can be closed so indicated conditions for system operations can be met.

3.4 GENERAL PROCEDURES FOR TESTING AND BALANCING

- A. Perform testing and balancing procedures on each system according to the procedures contained in this section and:
 - 1. AABC's "National Standards for Total System Balance"
 - 2. Comply with requirements in ASHRAE 62.1, Section 7.2.2 - "Air Balancing."
- B. Cut insulation, ducts, pipes, and equipment cabinets for installation of test probes to the minimum extent necessary for TAB procedures.
 - 1. After testing and balancing, patch probe holes in ducts with same material and thickness as used to construct ducts.
 - 2. Install and join new insulation that matches removed materials. Restore insulation, coverings, vapor barrier, and finish according to Division 23 Section "Duct Insulation," Division 23 Section "HVAC Equipment Insulation," and Division 23 Section "HVAC Piping Insulation."
- C. Mark equipment and balancing devices, including damper-control positions, valve position indicators, fan-speed-control levers, and similar controls and devices, with paint or other suitable, permanent identification material to show final settings.
- D. Take and report testing and balancing measurements in inch-pound (IP) .

3.5 GENERAL PROCEDURES FOR BALANCING AIR SYSTEMS

- A. Prepare test reports for both fans and outlets. Obtain manufacturer's outlet factors and recommended testing procedures. Crosscheck the summation of required outlet volumes with required fan volumes.
- B. Prepare schematic diagrams of systems' "as-built" duct layouts.
- C. For variable-air-volume systems, develop a plan to simulate diversity.
- D. Determine the best locations in main and branch ducts for accurate duct-airflow measurements.
- E. Check airflow patterns from the outdoor-air louvers and dampers and the return- and exhaust-air dampers through the supply-fan discharge and mixing dampers.
- F. Locate start-stop and disconnect switches, electrical interlocks, and motor starters.
- G. Verify that motor starters are equipped with properly sized thermal protection.
- H. Check dampers for proper position to achieve desired airflow path.
- I. Check for airflow blockages.
- J. Check condensate drains for proper connections and functioning.
- K. Check for proper sealing of air-handling-unit components.
- L. Verify that air duct system is sealed as specified in Division 23 Section "Metal Ducts."

3.6 PROCEDURES FOR CONSTANT-VOLUME AIR SYSTEMS

- A. Adjust fans to deliver total indicated airflows within the maximum allowable fan speed listed by fan manufacturer.
1. Measure total airflow.
 - a. Where sufficient space in ducts is unavailable for Pitot-tube traverse measurements, measure airflow at terminal outlets and inlets and calculate the total airflow.
 2. Measure fan static pressures as follows to determine actual static pressure:
 - a. Measure outlet static pressure as far downstream from the fan as practical and upstream from restrictions in ducts such as elbows and transitions.
 - b. Measure static pressure directly at the fan outlet or through the flexible connection.
 - c. Measure inlet static pressure of single-inlet fans in the inlet duct as near the fan as possible, upstream from the flexible connection, and downstream from duct restrictions.
 - d. Measure inlet static pressure of double-inlet fans through the wall of the plenum that houses the fan.
 3. Measure static pressure across each component that makes up an air-handling unit, rooftop unit, and other air-handling and -treating equipment.
 - a. Report the cleanliness status of filters and the time static pressures are measured.
 4. Measure static pressures entering and leaving other devices, such as sound traps, heat-recovery equipment, and air washers, under final balanced conditions.
 5. Review Record Documents to determine variations in design static pressures versus actual static pressures. Calculate actual system-effect factors. Recommend adjustments to accommodate actual conditions.
 6. Obtain approval from one of the following entities for adjustment of fan speed higher or lower than indicated speed. Comply with requirements in HVAC Sections for air-handling units for adjustment of fans, belts, and pulley sizes to achieve indicated air-handling-unit performance:
 - a. Architect.
 7. Do not make fan-speed adjustments that result in motor overload. Consult equipment manufacturers about fan-speed safety factors. Modulate dampers and measure fan-motor amperage to ensure that no overload will occur. Measure amperage in full-cooling, full-heating, economizer, and any other operating mode to determine the maximum required brake horsepower.
- B. Adjust volume dampers for main duct, submain ducts, and major branch ducts to indicated airflows within specified tolerances.
1. Measure airflow of submain and branch ducts.
 - a. Where sufficient space in submain and branch ducts is unavailable for Pitot-tube traverse measurements, measure airflow at terminal outlets and inlets and calculate the total airflow for that zone.
 2. Measure static pressure at a point downstream from the balancing damper, and adjust volume dampers until the proper static pressure is achieved.
 3. Remeasure each submain and branch duct after all have been adjusted. Continue to adjust submain and branch ducts to indicated airflows within specified tolerances.
- C. Measure air outlets and inlets without making adjustments.

1. Measure terminal outlets using a direct-reading hood or outlet manufacturer's written instructions and calculating factors.
- D. Adjust air outlets and inlets for each space to indicated airflows within specified tolerances of indicated values. Make adjustments using branch volume dampers rather than extractors and the dampers at air terminals.
1. Adjust each outlet in same room or space to within specified tolerances of indicated quantities without generating noise levels above the limitations prescribed by the Contract Documents.
 2. Adjust patterns of adjustable outlets for proper distribution without drafts.

3.7 PROCEDURES FOR VARIABLE-AIR-VOLUME SYSTEMS

- A. Compensating for Diversity: When the total airflow of all terminal units is more than the indicated airflow of the fan, place a selected number of terminal units at a minimum set-point airflow with the remainder at maximum-airflow condition until the total airflow of the terminal units equals the indicated airflow of the fan. Select the reduced-airflow terminal units so they are distributed evenly among the branch ducts.
- B. Pressure-Independent, Variable-Air-Volume Systems: After the fan systems have been adjusted, adjust the variable-air-volume systems as follows:
1. Set outdoor-air dampers at minimum, and set return- and exhaust-air dampers at a position that simulates full-cooling load.
 2. Select the terminal unit that is most critical to the supply-fan airflow and static pressure. Measure static pressure. Adjust system static pressure so the entering static pressure for the critical terminal unit is not less than the sum of the terminal-unit manufacturer's recommended minimum inlet static pressure plus the static pressure needed to overcome terminal-unit discharge system losses.
 3. Measure total system airflow. Adjust to within indicated airflow.
 4. Set terminal units at maximum airflow and adjust controller or regulator to deliver the designed maximum airflow. Use terminal-unit manufacturer's written instructions to make this adjustment. When total airflow is correct, balance the air outlets downstream from terminal units the same as described for constant-volume air systems.
 5. Set terminal units at minimum airflow and adjust controller or regulator to deliver the designed minimum airflow. Check air outlets for a proportional reduction in airflow the same as described for constant-volume air systems.
 - a. If air outlets are out of balance at minimum airflow, report the condition but leave outlets balanced for maximum airflow.
 6. Remeasure the return airflow to the fan while operating at maximum return airflow and minimum outdoor airflow.
 7. Measure static pressure at the most critical terminal unit and adjust the static-pressure controller at the main supply-air sensing station to ensure that adequate static pressure is maintained at the most critical unit.
 8. Record final fan-performance data.
- C. Pressure-Dependent, Variable-Air-Volume Systems without Diversity: After the fan systems have been adjusted, adjust the variable-air-volume systems as follows:
1. Balance variable-air-volume systems the same as described for constant-volume air systems.
 2. Set terminal units and supply fan at full-airflow condition.

3. Adjust inlet dampers of each terminal unit to indicated airflow and verify operation of the static-pressure controller. When total airflow is correct, balance the air outlets downstream from terminal units the same as described for constant-volume air systems.
 4. Readjust fan airflow for final maximum readings.
 5. Measure operating static pressure at the sensor that controls the supply fan if one is installed, and verify operation of the static-pressure controller.
 6. Set terminal units at minimum airflow and adjust controller or regulator to deliver the designed minimum airflow. Check air outlets for a proportional reduction in airflow the same as described for constant-volume air systems.
 - a. If air outlets are out of balance at minimum airflow, report the condition but leave the outlets balanced for maximum airflow.
 7. Measure the return airflow to the fan while operating at maximum return airflow and minimum outdoor airflow.
- D. Pressure-Dependent, Variable-Air-Volume Systems with Diversity: After the fan systems have been adjusted, adjust the variable-air-volume systems as follows:
1. Set system at maximum indicated airflow by setting the required number of terminal units at minimum airflow. Select the reduced-airflow terminal units so they are distributed evenly among the branch ducts.
 2. Adjust supply fan to maximum indicated airflow with the variable-airflow controller set at maximum airflow.
 3. Set terminal units at full-airflow condition.
 4. Adjust terminal units starting at the supply-fan end of the system and continuing progressively to the end of the system. Adjust inlet dampers of each terminal unit to indicated airflow. When total airflow is correct, balance the air outlets downstream from terminal units the same as described for constant-volume air systems.
 5. Adjust terminal units for minimum airflow.
 6. Measure the return airflow to the fan while operating at maximum return airflow and minimum outdoor airflow. Adjust the fan and balance the return-air ducts and inlets the same as described for constant-volume air systems.

3.8 GENERAL PROCEDURES FOR HYDRONIC SYSTEMS

- A. Prepare test reports with pertinent design data, and number in sequence starting at pump to end of system. Check the sum of branch-circuit flows against the approved pump flow rate. Correct variations that exceed plus or minus 5 percent.
- B. Prepare schematic diagrams of systems' "as-built" piping layouts.
- C. Prepare hydronic systems for testing and balancing according to the following, in addition to the general preparation procedures specified above:
 1. Open all manual valves for maximum flow.
 2. Check liquid level in expansion tank.
 3. Check makeup water-station pressure gage for adequate pressure for highest vent.
 4. Check flow-control valves for specified sequence of operation, and set at indicated flow.
 5. Set differential-pressure control valves at the specified differential pressure. Do not set at fully closed position when pump is positive-displacement type unless several terminal valves are kept open.
 6. Set system controls so automatic valves are wide open to heat exchangers.
 7. Check pump-motor load. If motor is overloaded, throttle main flow-balancing device so motor nameplate rating is not exceeded.

8. Check air vents for a forceful liquid flow exiting from vents when manually operated.

3.9 PROCEDURES FOR CONSTANT-FLOW HYDRONIC SYSTEMS

- A. Measure water flow at pumps. Use the following procedures except for positive-displacement pumps:
 1. Verify impeller size by operating the pump with the discharge valve closed. Read pressure differential across the pump. Convert pressure to head and correct for differences in gage heights. Note the point on manufacturer's pump curve at zero flow and verify that the pump has the intended impeller size.
 - a. If impeller sizes must be adjusted to achieve pump performance, obtain approval from the following entity and comply with requirements in Division 23 Section "Hydronic Pumps":
 - 1) Architect.
 2. Check system resistance. With all valves open, read pressure differential across the pump and mark pump manufacturer's head-capacity curve. Adjust pump discharge valve until indicated water flow is achieved.
 - a. Monitor motor performance during procedures and do not operate motors in overload conditions.
 3. Verify pump-motor brake horsepower. Calculate the intended brake horsepower for the system based on pump manufacturer's performance data. Compare calculated brake horsepower with nameplate data on the pump motor. Report conditions where actual amperage exceeds motor nameplate amperage.
 4. Report flow rates that are not within plus or minus 10 percent of design.
- B. Measure flow at all automatic flow control valves to verify that valves are functioning as designed.
- C. Measure flow at all pressure-independent characterized control valves, with valves in fully open position, to verify that valves are functioning as designed.
- D. Set calibrated balancing valves, if installed, at calculated presettings.
- E. Measure flow at all stations and adjust, where necessary, to obtain first balance.
 1. System components that have Cv rating or an accurately cataloged flow-pressure-drop relationship may be used as a flow-indicating device.
- F. Measure flow at main balancing station and set main balancing device to achieve flow that is 5 percent greater than indicated flow.
- G. Adjust balancing stations to within specified tolerances of indicated flow rate as follows:
 1. Determine the balancing station with the highest percentage over indicated flow.
 2. Adjust each station in turn, beginning with the station with the highest percentage over indicated flow and proceeding to the station with the lowest percentage over indicated flow.
 3. Record settings and mark balancing devices.
- H. Measure pump flow rate and make final measurements of pump amperage, voltage, rpm, pump heads, and systems' pressures and temperatures including outdoor-air temperature.

- I. Measure the differential-pressure-control-valve settings existing at the conclusion of balancing.
- J. Check settings and operation of each safety valve. Record settings.

3.10 PROCEDURES FOR VARIABLE-FLOW HYDRONIC SYSTEMS

- A. Balance systems with automatic two- and three-way control valves by setting systems at maximum flow through heat-exchange terminals and proceed as specified above for hydronic systems.

3.11 PROCEDURES FOR PRIMARY-SECONDARY HYDRONIC SYSTEMS

- A. Balance the primary circuit flow first and then balance the secondary circuits.

3.12 PROCEDURES FOR STEAM SYSTEMS

- A. Measure and record upstream and downstream pressure of each piece of equipment.
- B. Measure and record upstream and downstream steam pressure of pressure-reducing valves.
- C. Check settings and operation of automatic temperature-control valves, self-contained control valves, and pressure-reducing valves. Record final settings.
- D. Check settings and operation of each safety valve. Record settings.
- E. Verify the operation of each steam trap.

3.13 PROCEDURES FOR HEAT EXCHANGERS

- A. Measure water flow through all circuits.
- B. Adjust water flow to within specified tolerances.
- C. Measure inlet and outlet water temperatures.
- D. Measure inlet steam pressure.
- E. Check settings and operation of safety and relief valves. Record settings.

3.14 PROCEDURES FOR MOTORS

- A. Motors, 1/2 HP and Larger: Test at final balanced conditions and record the following data:
 - 1. Manufacturer's name, model number, and serial number.
 - 2. Motor horsepower rating.
 - 3. Motor rpm.
 - 4. Efficiency rating.
 - 5. Motor balanced frequency and the date & time it was balanced.
 - 6. Drive kW.
 - 7. Drive torque.
 - 8. Nameplate and measured voltage, each phase.
 - 9. Nameplate and measured amperage, each phase.
 - 10. Starter thermal-protection-element rating.

- B. Motors Driven by Variable-Frequency Controllers: Test for proper operation at speeds varying from minimum to maximum. Test the manual bypass of the controller to prove proper operation. Record observations including name of controller manufacturer, model number, serial number, and nameplate data.

3.15 PROCEDURES FOR CHILLERS

- A. Balance water flow through each evaporator and condenser to within specified tolerances of indicated flow with all pumps operating. With only one chiller operating in a multiple chiller installation, do not exceed the flow for the maximum tube velocity recommended by the chiller manufacturer. Measure and record the following data with each chiller operating at design conditions:
 - 1. Evaporator-water entering and leaving temperatures, pressure drop, and water flow.
 - 2. For water-cooled chillers, condenser-water entering and leaving temperatures, pressure drop, and water flow.
 - 3. Evaporator and condenser refrigerant temperatures and pressures, using instruments furnished by chiller manufacturer.
 - 4. Power factor if factory-installed instrumentation is furnished for measuring kilowatts.
 - 5. Kilowatt input if factory-installed instrumentation is furnished for measuring kilowatts.
 - 6. Capacity: Calculate in tons of cooling.
 - 7. For air-cooled chillers, verify condenser-fan rotation and record fan and motor data including number of fans and entering- and leaving-air temperatures.

3.16 PROCEDURES FOR COOLING TOWERS

- A. Shut off makeup water for the duration of the test, and verify that makeup and blowdown systems are fully operational after tests and before leaving the equipment. Perform the following tests and record the results:
 - 1. Measure condenser-water flow to each cell of the cooling tower.
 - 2. Measure entering- and leaving-water temperatures.
 - 3. Measure wet- and dry-bulb temperatures of entering air.
 - 4. Measure wet- and dry-bulb temperatures of leaving air.
 - 5. Measure condenser-water flow rate recirculating through the cooling tower.
 - 6. Measure cooling-tower spray pump discharge pressure.
 - 7. Adjust water level and feed rate of makeup water system.
 - 8. Measure flow through bypass.

3.17 PROCEDURES FOR CONDENSING UNITS

- A. Verify proper rotation of fans.
- B. Measure entering- and leaving-air temperatures.
- C. Record compressor data.

3.18 PROCEDURES FOR HEAT-TRANSFER COILS

- A. Measure, adjust, and record the following data for each water coil:
 - 1. Entering- and leaving-water temperature.
 - 2. Water flow rate.
 - 3. Water pressure drop.

4. Dry-bulb temperature of entering and leaving air.
 5. Wet-bulb temperature of entering and leaving air for cooling coils.
 6. Airflow.
 7. Air pressure drop.
- B. Measure, adjust, and record the following data for each electric heating coil:
1. Nameplate data.
 2. Airflow.
 3. Entering- and leaving-air temperature at full load.
 4. Voltage and amperage input of each phase at full load and at each incremental stage.
 5. Calculated kilowatt at full load.
 6. Fuse or circuit-breaker rating for overload protection.
- C. Measure, adjust, and record the following data for each steam coil:
1. Dry-bulb temperature of entering and leaving air.
 2. Airflow.
 3. Air pressure drop.
 4. Inlet steam pressure.
- D. Measure, adjust, and record the following data for each refrigerant coil:
1. Dry-bulb temperature of entering and leaving air.
 2. Wet-bulb temperature of entering and leaving air.
 3. Airflow.
 4. Air pressure drop.
 5. Refrigerant suction pressure and temperature.

3.19 DOMESTIC HEATER SYSTEMS

- A. Test domestic heater system per Engineer's instructions.

3.20 AIRBORNE INFECTIOUS ISOLATION (AII) & PROTECTIVE ENVIRONMENT (PE) ROOMS

- A. After construction has been completed, but prior to occupancy in these rooms the TAB contractor is to measure, adjust, record, and report the following data for each AII or PE room:
1. Supply airflow.
 2. Return airflow.
 3. Exhaust airflow.
 4. Room pressure relative to adjacent spaces.
 5. Prove that the room will maintain either a positive or negative 0.03-inch WC pressure differential, depending on the room's pressure requirement as called for by the design engineer.
 6. Proper operation of room controls.
 7. Functionality of pressure monitors & alarms.

3.21 TOLERANCES

- A. Set HVAC system's air flow rates and water flow rates within the following tolerances:
1. Supply, Return, and Exhaust Fans and Equipment with Fans: Plus or minus 10 percent.
 2. Air Outlets and Inlets: Plus or minus 10 percent.
 3. Heating-Water Flow Rate: Plus or minus 10 percent.

4. Cooling-Water Flow Rate: Plus or minus 10 percent.

3.22 REPORTING

- A. Initial Construction-Phase Report: Based on examination of the Contract Documents as specified in "Examination" Article, prepare a report on the adequacy of design for systems' balancing devices. Recommend changes and additions to systems' balancing devices to facilitate proper performance measuring and balancing. Recommend changes and additions to HVAC systems and general construction to allow access for performance measuring and balancing devices.
- B. Status Reports: Prepare progress reports on the following interval to describe completed procedures, procedures in progress, and scheduled procedures. Include a list of deficiencies and problems found in systems being tested and balanced. Prepare a separate report for each system and each building floor for systems serving multiple floors;
 1. Weekly.

3.23 FINAL REPORT

- A. General: Prepare a certified written report; tabulate and divide the report into separate sections for tested systems and balanced systems.
 1. Include a certification sheet at the front of the report's binder, signed and sealed by the certified testing and balancing engineer.
 2. Include a list of instruments used for procedures, along with proof of calibration.
- B. Final Report Contents: In addition to certified field-report data, include the following:
 1. Pump curves.
 2. Fan curves.
 3. Manufacturers' test data.
 4. Field test reports prepared by system and equipment installers.
 5. Other information relative to equipment performance; do not include Shop Drawings and product data.
- C. General Report Data: In addition to form titles and entries, include the following data:
 1. Title page.
 2. Name and address of the TAB contractor.
 3. Project name.
 4. Project location.
 5. Architect's name and address.
 6. Engineer's name and address.
 7. Contractor's name and address.
 8. Report date.
 9. Signature of TAB supervisor who certifies the report.
 10. Table of Contents with the total number of pages defined for each section of the report. Number each page in the report.
 11. Summary of contents including the following:
 - a. Indicated versus final performance.
 - b. Notable characteristics of systems.
 - c. Description of system operation sequence if it varies from the Contract Documents.
 12. Nomenclature sheets for each item of equipment.

13. Data for terminal units, including manufacturer's name, type, size, and fittings.
 14. Notes to explain why certain final data in the body of reports vary from indicated values.
 15. Test conditions for fans and pump performance forms including the following:
 - a. Settings for outdoor-, return-, and exhaust-air dampers.
 - b. Conditions of filters.
 - c. Cooling coil, wet- and dry-bulb conditions.
 - d. Face and bypass damper settings at coils.
 - e. Fan drive settings including settings and percentage of maximum pitch diameter.
 - f. Inlet vane settings for variable-air-volume systems.
 - g. Settings for supply-air, static-pressure controller.
 - h. Other system operating conditions that affect performance.
- D. System Diagrams: Include schematic layouts of air and hydronic distribution systems. Present each system with single-line diagram and include the following:
1. Quantities of outdoor, supply, return, and exhaust airflows.
 2. Water and steam flow rates.
 3. Duct, outlet, and inlet sizes.
 4. Pipe and valve sizes and locations.
 5. Terminal units.
 6. Balancing stations.
 7. Position of balancing devices.
- E. Air-Handling-Unit Test Reports: For air-handling units with coils, include the following:
1. Unit Data:
 - a. Unit identification.
 - b. Location.
 - c. Make and type.
 - d. Model number and unit size.
 - e. Manufacturer's serial number.
 - f. Unit arrangement and class.
 - g. Discharge arrangement.
 - h. Sheave make, size in inches, and bore.
 - i. Center-to-center dimensions of sheave, and amount of adjustments in inches.
 - j. Number, make, and size of belts.
 - k. Number, type, and size of filters.
 2. Motor Data:
 - a. Motor make, and frame type and size.
 - b. Horsepower and rpm.
 - c. Volts, phase, and hertz.
 - d. Full-load amperage and service factor.
 - e. Sheave make, size in inches, and bore.
 - f. Center-to-center dimensions of sheave, and amount of adjustments in inches.
 3. Test Data (Indicated and Actual Values):
 - a. Total air flow rate in cfm.
 - b. Total system static pressure in inches wg.
 - c. Fan rpm.
 - d. Discharge static pressure in inches wg.
 - e. Filter static-pressure differential in inches wg.
 - f. Preheat-coil static-pressure differential in inches wg.

- g. Cooling-coil static-pressure differential in inches wg.
- h. Heating-coil static-pressure differential in inches wg.
- i. Outdoor airflow in cfm.
- j. Return airflow in cfm.
- k. Outdoor-air damper position.
- l. Return-air damper position.
- m. Vortex damper position.

F. Apparatus-Coil Test Reports:

1. Coil Data:

- a. System identification.
- b. Location.
- c. Coil type.
- d. Number of rows.
- e. Fin spacing in fins per inch o.c.
- f. Make and model number.
- g. Face area in sq. ft..
- h. Tube size in NPS.
- i. Tube and fin materials.
- j. Circuiting arrangement.

2. Test Data (Indicated and Actual Values):

- a. Air flow rate in cfm.
- b. Average face velocity in fpm.
- c. Air pressure drop in inches wg.
- d. Outdoor-air, wet- and dry-bulb temperatures in deg F.
- e. Return-air, wet- and dry-bulb temperatures in deg F.
- f. Entering-air, wet- and dry-bulb temperatures in deg F.
- g. Leaving-air, wet- and dry-bulb temperatures in deg F.
- h. Water flow rate in gpm.
- i. Water pressure differential in feet of head or psig.
- j. Entering-water temperature in deg F.
- k. Leaving-water temperature in deg F.
- l. Refrigerant expansion valve and refrigerant types.
- m. Refrigerant suction pressure in psig.
- n. Refrigerant suction temperature in deg F.
- o. Inlet steam pressure in psig.

G. Gas- and Oil-Fired Heat Apparatus Test Reports: In addition to manufacturer's factory startup equipment reports, include the following:

1. Unit Data:

- a. System identification.
- b. Location.
- c. Make and type.
- d. Model number and unit size.
- e. Manufacturer's serial number.
- f. Fuel type in input data.
- g. Output capacity in Btu/h.
- h. Ignition type.
- i. Burner-control types.
- j. Motor horsepower and rpm.
- k. Motor volts, phase, and hertz.
- l. Motor full-load amperage and service factor.

- m. Sheave make, size in inches, and bore.
- n. Center-to-center dimensions of sheave, and amount of adjustments in inches.

2. Test Data (Indicated and Actual Values):

- a. Total air flow rate in cfm.
- b. Entering-air temperature in deg F.
- c. Leaving-air temperature in deg F.
- d. Air temperature differential in deg F.
- e. Entering-air static pressure in inches wg.
- f. Leaving-air static pressure in inches wg.
- g. Air static-pressure differential in inches wg.
- h. Low-fire fuel input in Btu/h.
- i. High-fire fuel input in Btu/h.
- j. Manifold pressure in psig.
- k. High-temperature-limit setting in deg F.
- l. Operating set point in Btu/h.
- m. Motor voltage at each connection.
- n. Motor amperage for each phase.
- o. Heating value of fuel in Btu/h.

H. Fan Test Reports: For supply, return, and exhaust fans, include the following:

1. Fan Data:

- a. System identification.
- b. Location.
- c. Make and type.
- d. Model number and size.
- e. Manufacturer's serial number.
- f. Arrangement and class.
- g. Sheave make, size in inches, and bore.
- h. Center-to-center dimensions of sheave, and amount of adjustments in inches.

2. Motor Data:

- a. Motor make, and frame type and size.
- b. Horsepower and rpm.
- c. Volts, phase, and hertz.
- d. Full-load amperage and service factor.
- e. Sheave make, size in inches, and bore.
- f. Center-to-center dimensions of sheave, and amount of adjustments in inches.
- g. Number, make, and size of belts.

3. Test Data (Indicated and Actual Values):

- a. Total airflow rate in cfm.
- b. Total system static pressure in inches wg.
- c. Fan rpm.
- d. Discharge static pressure in inches wg.
- e. Suction static pressure in inches wg.

I. Round, Flat-Oval, and Rectangular Duct Traverse Reports: Include a diagram with a grid representing the duct cross-section and record the following:

1. Report Data:

- a. System and air-handling-unit number.

- b. Location and zone.
- c. Traverse air temperature in deg F.
- d. Duct static pressure in inches wg.
- e. Duct size in inches.
- f. Duct area in sq. ft..
- g. Indicated air flow rate in cfm.
- h. Indicated velocity in fpm.
- i. Actual air flow rate in cfm.
- j. Actual average velocity in fpm.
- k. Barometric pressure in psig.

J. Air-Terminal-Device Reports:

1. Unit Data:

- a. System and air-handling unit identification.
- b. Location and zone.
- c. Apparatus used for test.
- d. Area served.
- e. Make.
- f. Number from system diagram.
- g. Type and model number.
- h. Size.
- i. Effective area in sq. ft..

2. Test Data (Indicated and Actual Values):

- a. Air flow rate in cfm.
- b. Air velocity in fpm.
- c. Preliminary air flow rate as needed in cfm.
- d. Preliminary velocity as needed in fpm.
- e. Final air flow rate in cfm.
- f. Final velocity in fpm.
- g. Space temperature in deg F.

K. System-Coil Reports: For reheat coils and water coils of terminal units, include the following:

1. Unit Data:

- a. System and air-handling-unit identification.
- b. Location and zone.
- c. Room or riser served.
- d. Coil make and size.
- e. Flowmeter type.

2. Test Data (Indicated and Actual Values):

- a. Air flow rate in cfm.
- b. Entering-water temperature in deg F.
- c. Leaving-water temperature in deg F.
- d. Water pressure drop in feet of head or psig.
- e. Entering-air temperature in deg F.
- f. Leaving-air temperature in deg F.

L. Pump Test Reports: Calculate impeller size by plotting the shutoff head on pump curves and include the following:

1. Unit Data:

- a. Unit identification.
- b. Location.
- c. Service.
- d. Make and size.
- e. Model number and serial number.
- f. Water flow rate in gpm.
- g. Water pressure differential in feet of head or psig.
- h. Required net positive suction head in feet of head or psig.
- i. Pump rpm.
- j. Impeller diameter in inches.
- k. Motor make and frame size.
- l. Motor horsepower and rpm.
- m. Voltage at each connection.
- n. Amperage for each phase.
- o. Full-load amperage and service factor.
- p. Seal type.

2. Test Data (Indicated and Actual Values):

- a. Static head in feet of head or psig.
- b. Pump shutoff pressure in feet of head or psig.
- c. Actual impeller size in inches.
- d. Full-open flow rate in gpm.
- e. Full-open pressure in feet of head or psig.
- f. Final discharge pressure in feet of head or psig.
- g. Final suction pressure in feet of head or psig.
- h. Final total pressure in feet of head or psig.
- i. Final water flow rate in gpm.
- j. Voltage at each connection.
- k. Amperage for each phase.

M. Instrument Calibration Reports:

1. Report Data:

- a. Instrument type and make.
- b. Serial number.
- c. Application.
- d. Dates of use.
- e. Dates of calibration.

3.24 INSPECTIONS

A. Initial Inspection:

- 1. After testing and balancing are complete, operate each system and randomly check measurements to verify that the system is operating according to the final test and balance readings documented in the final report.
- 2. Check the following for each system:
 - a. Measure airflow of at least 10 percent of air outlets.
 - b. Measure water flow of at least 5 percent of terminals.
 - c. Measure room temperature at each thermostat/temperature sensor. Compare the reading to the set point.
 - d. Verify that balancing devices are marked with final balance position.
 - e. Note deviations from the Contract Documents in the final report.

B. Final Inspection:

1. After initial inspection is complete and documentation by random checks verifies that testing and balancing are complete and accurately documented in the final report, request that a final inspection be made by:
 - a. Architect.
2. The TAB contractor's test and balance engineer shall conduct the inspection in the presence of:
 - a. Architect.
3. The following entity shall randomly select measurements, documented in the final report, to be rechecked. Rechecking shall be limited to either 10 percent of the total measurements recorded or the extent of measurements that can be accomplished in a normal 8-hour business day:
 - a. Architect.
4. If rechecks yield measurements that differ from the measurements documented in the final report by more than the tolerances allowed, the measurements shall be noted as "FAILED."
5. If the number of "FAILED" measurements is greater than 10 percent of the total measurements checked during the final inspection, the testing and balancing shall be considered incomplete and shall be rejected.

C. TAB Work will be considered defective if it does not pass final inspections. If TAB Work fails, proceed as follows:

1. Recheck all measurements and make adjustments. Revise the final report and balancing device settings to include all changes; resubmit the final report and request a second final inspection.
2. If the second final inspection also fails, Owner may contract the services of another TAB contractor to complete TAB Work according to the Contract Documents and deduct the cost of the services from the original TAB contractor's final payment.

D. Prepare test and inspection reports.

3.25 ADDITIONAL TESTS

- A. Within 90 days of completing TAB, perform additional TAB to verify that balanced conditions are being maintained throughout and to correct unusual conditions.
- B. Seasonal Periods: If initial TAB procedures were not performed during near-peak summer and winter conditions, perform additional TAB during near-peak summer and winter conditions.

END OF SECTION 23 0593

THIS PAGE LEFT BLANK INTENTIONALLY

SECTION 23 0713

DUCT INSULATION

PART 1 - GENERAL

1.1 RELATED DOCUMENTS

- A. Drawings and general provisions of the Contract, including General and Supplementary Conditions and Division 01 Specification Sections, apply to this Section.

1.2 SUMMARY

- A. Section includes insulating the following duct services:
 - 1. Indoor, concealed supply and outdoor air.
 - 2. Indoor, exposed supply and outdoor air.
 - 3. Indoor, concealed return located in unconditioned space.
 - 4. Indoor, exposed return located in unconditioned space.
 - 5. Outdoor, concealed supply and return.
 - 6. Outdoor, exposed supply and return.
- B. Related Sections:
 - 1. Division 23 Section "HVAC Equipment Insulation."
 - 2. Division 23 Section "HVAC Piping Insulation."
 - 3. Division 23 Section "Metal Ducts" for duct liners.
 - 4. Division 23 Section "Hangers and Supports for HVAC Piping and Equipment."

1.3 ACTION SUBMITTALS

- A. Product Data: For each type of product indicated. Include thermal conductivity, water-vapor permeance thickness, and jackets (both factory- and field-applied if any).
- B. LEED Submittals:
 - 1. Product Data for Credit IEQ 4.1: For adhesives and sealants, documentation including printed statement of VOC content.
 - 2. Laboratory Test Reports for Credit IEQ 4: For adhesives and sealants, documentation indicating that products comply with the testing and product requirements of the California Department of Health Services' "Standard Practice for the Testing of Volatile Organic Emissions from Various Sources Using Small-Scale Environmental Chambers."
- C. Shop Drawings: Include plans, elevations, sections, details, and attachments to other work.
 - 1. Detail application of protective shields, saddles, and inserts at hangers for each type of insulation and hanger.
 - 2. Detail insulation application at elbows, fittings, dampers, specialties and flanges for each type of insulation.
 - 3. Detail application of field-applied jackets.
 - 4. Detail application at linkages of control devices.

1.4 INFORMATIONAL SUBMITTALS

- A. Qualification Data: For qualified Installer.
- B. Material Test Reports: From a qualified testing agency acceptable to authorities having jurisdiction indicating, interpreting, and certifying test results for compliance of insulation materials, sealers, attachments, cements, and jackets, with requirements indicated. Include dates of tests and test methods employed.
- C. Field quality-control reports.

1.5 QUALITY ASSURANCE

- A. Installer Qualifications: Skilled mechanics who have successfully completed an apprenticeship program or another craft training program certified by the Department of Labor, Bureau of Apprenticeship and Training.
- B. Surface-Burning Characteristics: For insulation and related materials, as determined by testing identical products according to ASTM E 84, by a testing agency acceptable to authorities having jurisdiction. Factory label insulation and jacket materials and adhesive, mastic, tapes, and cement material containers, with appropriate markings of applicable testing agency.
 - 1. Insulation Installed Indoors: Flame-spread index of 25 or less, and smoke-developed index of 50 or less.
 - 2. Insulation Installed Outdoors: Flame-spread index of 75 or less, and smoke-developed index of 150 or less.

1.6 DELIVERY, STORAGE, AND HANDLING

- A. Packaging: Insulation material containers shall be marked by manufacturer with appropriate ASTM standard designation, type and grade, and maximum use temperature.

1.7 COORDINATION

- A. Coordinate sizes and locations of supports, hangers, and insulation shields specified in Division 23 Section "Hangers and Supports for HVAC Piping and Equipment."
- B. Coordinate clearance requirements with duct Installer for duct insulation application. Before preparing ductwork Shop Drawings, establish and maintain clearance requirements for installation of insulation and field-applied jackets and finishes and for space required for maintenance.
- C. Coordinate installation and testing of heat tracing.

1.8 SCHEDULING

- A. Schedule insulation application after pressure testing systems and, where required, after installing and testing heat tracing. Insulation application may begin on segments that have satisfactory test results.
- B. Complete installation and concealment of plastic materials as rapidly as possible in each area of construction.

PART 2 - PRODUCTS

2.1 INSULATION MATERIALS

- A. Comply with requirements in "Duct Insulation Schedule, General," "Indoor Duct and Plenum Insulation Schedule," and "Aboveground, Outdoor Duct and Plenum Insulation Schedule" articles for where insulating materials shall be applied.
- B. Products shall not contain asbestos, lead, mercury, or mercury compounds.
- C. Products that come in contact with stainless steel shall have a leachable chloride content of less than 50 ppm when tested according to ASTM C 871.
- D. Insulation materials for use on austenitic stainless steel shall be qualified as acceptable according to ASTM C 795.
- E. Foam insulation materials shall not use CFC or HCFC blowing agents in the manufacturing process.
- F. Flexible Elastomeric Insulation: Closed-cell, sponge- or expanded-rubber materials. Comply with ASTM C 534, Type II for sheet materials.
 - 1. Products: Subject to compliance with requirements, provide one of the following:
 - a. Aeroflex USA, Inc.; Aerocel.
 - b. Armacell LLC; AP Armaflex.
 - c. K-Flex USA; Insul-Sheet, K-Flex Gray Duct Liner, and K-FLEX LS.
- G. Mineral-Fiber Blanket Insulation: Mineral or glass fibers bonded with a thermosetting resin. Comply with ASTM C 553, Type II and ASTM C 1290, Type III with factory-applied FSK jacket. Factory-applied jacket requirements are specified in "Factory-Applied Jackets" Article.
 - 1. Products: Subject to compliance with requirements, provide one of the following:
 - a. CertainTeed Corp.; SoftTouch Duct Wrap.
 - b. Johns Manville; Microlite.
 - c. Knauf Insulation; Friendly Feel Duct Wrap.
 - d. Manson Insulation Inc.; Alley Wrap.
 - e. Owens Corning; SOFTR All-Service Duct Wrap.
- H. Mineral-Fiber Board Insulation: Mineral or glass fibers bonded with a thermosetting resin. Comply with ASTM C 612, Type IA or Type IB. For duct and plenum applications, provide insulation with factory-applied ASJ. Factory-applied jacket requirements are specified in "Factory-Applied Jackets" Article.
 - 1. Products: Subject to compliance with requirements, provide one of the following:
 - a. CertainTeed Corp.; Commercial Board.
 - b. Fibrex Insulations Inc.; FBX.
 - c. Johns Manville; 800 Series Spin-Glas.
 - d. Knauf Insulation; Insulation Board.
 - e. Manson Insulation Inc.; AK Board.
 - f. Owens Corning; Fiberglas 700 Series.
- I. Polyolefin: Unicellular, polyethylene thermal plastic insulation. Comply with ASTM C 534 or ASTM C 1427, Type I, Grade 1 for tubular materials and Type II, Grade 1 for sheet materials.
 - 1. Products: Subject to compliance with requirements, provide one of the following:

- a. Armacell LLC; Tubolit.
- b. Nomaco Insulation; IMCOLOCK, IMCOSHEET, NOMALOCK, and NOMAPLY.

2.2 FIRE-RATED INSULATION SYSTEMS

- A. Fire-Rated Board: Structural-grade, press-molded, xonolite calcium silicate, fireproofing board suitable for operating temperatures up to 1700 deg F. Comply with ASTM C 656, Type II, Grade 6. Tested and certified to provide a:
 - a. 2-hour fire rating by an NRTL acceptable to authorities having jurisdiction
- 1. Products: Subject to compliance with requirements, provide the following :
 - a. Johns Manville; Super Firetemp M.
- B. Fire-Rated Blanket: High-temperature, flexible, blanket insulation with FSK jacket that is tested and certified to provide a:
 - a. 2-hour fire rating by an NRTL acceptable to authorities
- 1. Products: Subject to compliance with requirements, provide one of the following :
 - a. CertainTeed Corp.; FlameChek.
 - b. Johns Manville; Firetemp Wrap.
 - c. Nelson Fire Stop Products; Nelson FSB Flameshield Blanket.
 - d. Thermal Ceramics; FireMaster Duct Wrap.
 - e. 3M; Fire Barrier Wrap Products.
 - f. Unifrax Corporation; FyreWrap.

2.3 ADHESIVES

- A. Materials shall be compatible with insulation materials, jackets, and substrates and for bonding insulation to itself and to surfaces to be insulated unless otherwise indicated.
- B. Flexible Elastomeric and Polyolefin Adhesive: Comply with MIL-A-24179A, Type II, Class I.
 - 1. Products: Subject to compliance with requirements, provide one of the following:
 - a. Aeroflex USA, Inc.; AeroSeal.
 - b. Armacell LLC; Armaflex 520 Adhesive.
 - c. Foster Brand, Specialty Construction Brands, Inc., a business of H. B. Fuller Company; 85-75.
 - d. K-Flex USA; R-373 Contact Adhesive.
 - 2. For indoor applications, adhesive shall have a VOC content of 50 g/L or less when calculated according to 40 CFR 59, Subpart D (EPA Method 24).
- C. Mineral-Fiber Adhesive: Comply with MIL-A-3316C, Class 2, Grade A.
 - 1. Products: Subject to compliance with requirements, provide one of the following:
 - a. Childers Brand, Specialty Construction Brands, Inc., a business of H. B. Fuller Company; CP-127.
 - b. Eagle Bridges - Marathon Industries; 225.
 - c. Foster Brand, Specialty Construction Brands, Inc., a business of H. B. Fuller Company; 85-60/85-70.
 - d. Mon-Eco Industries, Inc.; 22-25.

2. For indoor applications, adhesive shall have a VOC content of 80 g/L or less when calculated according to 40 CFR 59, Subpart D (EPA Method 24).
- D. FSK Jacket Adhesive, and ASJ Adhesive: Comply with MIL-A-3316C, Class 2, Grade A for bonding insulation jacket lap seams and joints.
1. Products: Subject to compliance with requirements, provide one of the following:
 - a. Childers Brand, Specialty Construction Brands, Inc., a business of H. B. Fuller Company; CP-82.
 - b. Eagle Bridges - Marathon Industries; 225.
 - c. Foster Brand, Specialty Construction Brands, Inc., a business of H. B. Fuller Company; 85-50.
 - d. Mon-Eco Industries, Inc.; 22-25.
 2. For indoor applications, adhesive shall have a VOC content of 50 g/L or less when calculated according to 40 CFR 59, Subpart D (EPA Method 24).

2.4 MASTICS

- A. Materials shall be compatible with insulation materials, jackets, and substrates; comply with MIL-PRF-19565C, Type II.
1. For indoor applications, use mastics that have a VOC content of 50 g/L or less when calculated according to 40 CFR 59, Subpart D (EPA Method 24).
- B. Vapor-Barrier Mastic: Water based; suitable for indoor use on below ambient services.
1. Products: Subject to compliance with requirements, provide one of the following:
 - a. Foster Brand, Specialty Construction Brands, Inc., a business of H. B. Fuller Company; 30-80/30-90.
 - b. Vimasco Corporation; 749.
 2. Water-Vapor Permeance: ASTM E 96/E 96M, Procedure B, 0.013 perm at 43-mil dry film thickness.
 3. Service Temperature Range: Minus 20 to plus 180 deg F.
 4. Solids Content: ASTM D 1644, 58 percent by volume and 70 percent by weight.
 5. Color: White.
- C. Breather Mastic: Water based; suitable for indoor and outdoor use on above ambient services.
1. Products: Subject to compliance with requirements, provide one of the following:
 - a. Childers Brand, Specialty Construction Brands, Inc., a business of H. B. Fuller Company; CP-10.
 - b. Eagle Bridges - Marathon Industries; 550.
 - c. Foster Brand, Specialty Construction Brands, Inc., a business of H. B. Fuller Company; 46-50.
 - d. Mon-Eco Industries, Inc.; 55-50.
 - e. Vimasco Corporation; WC-1/WC-5.
 2. Water-Vapor Permeance: ASTM F 1249, 1.8 perms at 0.0625-inch dry film thickness.
 3. Service Temperature Range: Minus 20 to plus 180 deg F.
 4. Solids Content: 60 percent by volume and 66 percent by weight.
 5. Color: White.

2.5 LAGGING ADHESIVES

- A. Description: Comply with MIL-A-3316C, Class I, Grade A and shall be compatible with insulation materials, jackets, and substrates.
1. For indoor applications, use lagging adhesives that have a VOC content of 50 g/L or less when calculated according to 40 CFR 59, Subpart D (EPA Method 24).
 2. Products: Subject to compliance with requirements, provide one of the following:
 - a. Childers Brand, Specialty Construction Brands, Inc., a business of H. B. Fuller Company; CP-50 AHV2.
 - b. Foster Brand, Specialty Construction Brands, Inc., a business of H. B. Fuller Company; 30-36.
 - c. Vimasco Corporation; 713 and 714.
 3. Fire-resistant, water-based lagging adhesive and coating for use indoors to adhere fire-resistant lagging cloths over duct insulation.
 4. Service Temperature Range: 0 to plus 180 deg F.
 5. Color: White.

2.6 SEALANTS

- A. FSK and Metal Jacket Flashing Sealants:
1. Products: Subject to compliance with requirements, provide one of the following:
 - a. Childers Brand, Specialty Construction Brands, Inc., a business of H. B. Fuller Company; CP-76.
 - b. Eagle Bridges - Marathon Industries; 405.
 - c. Foster Brand, Specialty Construction Brands, Inc., a business of H. B. Fuller Company; 95-44.
 - d. Mon-Eco Industries, Inc.; 44-05.
 2. Materials shall be compatible with insulation materials, jackets, and substrates.
 3. Fire- and water-resistant, flexible, elastomeric sealant.
 4. Service Temperature Range: Minus 40 to plus 250 deg F.
 5. Color: Aluminum.
 6. For indoor applications, sealants shall have a VOC content of 420 g/L or less when calculated according to 40 CFR 59, Subpart D (EPA Method 24).

2.7 FACTORY-APPLIED JACKETS

- A. Insulation system schedules indicate factory-applied jackets on various applications. When factory-applied jackets are indicated, comply with the following:
1. FSK Jacket: Aluminum-foil, fiberglass-reinforced scrim with kraft-paper backing; complying with ASTM C 1136, Type II.

2.8 FIELD-APPLIED JACKETS

- A. Field-applied jackets shall comply with ASTM C 921, Type I, unless otherwise indicated.
- B. FSK Jacket: Aluminum-foil-face, fiberglass-reinforced scrim with kraft-paper backing.
- C. Metal Jacket:

1. Products: Subject to compliance with requirements, provide one of the following:
 - a. Childers Brand, Specialty Construction Brands, Inc., a business of H. B. Fuller Company; Metal Jacketing Systems.
 - b. ITW Insulation Systems; Aluminum and Stainless Steel Jacketing.
 - c. RPR Products, Inc.; Insul-Mate.

2. Aluminum Jacket: Comply with ASTM B 209, Alloy 3003, 3005, 3105, or 5005, Temper H-14.
 - a. Sheet and roll stock ready for shop or field sizing
 - b. Finish and thickness are indicated in field-applied jacket schedules.
 - c. Moisture Barrier for Indoor Applications: 3-mil-thick, heat-bonded polyethylene and kraft paper.
 - d. Moisture Barrier for Outdoor Applications: 3-mil-thick, heat-bonded polyethylene and kraft.

2.9 TAPES

- A. FSK Tape: Foil-face, vapor-retarder tape matching factory-applied jacket with acrylic adhesive; complying with ASTM C 1136.

1. Products: Subject to compliance with requirements, provide one of the following:
 - a. ABI, Ideal Tape Division; 491 AWF FSK.
 - b. Avery Dennison Corporation, Specialty Tapes Division; Fasson 0827.
 - c. Compac Corporation; 110 and 111.
 - d. Venture Tape; 1525 CW NT, 1528 CW, and 1528 CW/SQ.

2. Width: 3 inches.
3. Thickness: 6.5 mils.
4. Adhesion: 90 ounces force/inch in width.
5. Elongation: 2 percent.
6. Tensile Strength: 40 lbf/inch in width.
7. FSK Tape Disks and Squares: Precut disks or squares of FSK tape.

- B. Aluminum-Foil Tape: Vapor-retarder tape with acrylic adhesive.

1. Products: Subject to compliance with requirements, provide one of the following:
 - a. ABI, Ideal Tape Division; 488 AWF.
 - b. Avery Dennison Corporation, Specialty Tapes Division; Fasson 0800.
 - c. Compac Corporation; 120.
 - d. Venture Tape; 3520 CW.

2. Width: 2 inches.
3. Thickness: 3.7 mils.
4. Adhesion: 100 ounces force/inch in width.
5. Elongation: 5 percent.
6. Tensile Strength: 34 lbf/inch in width.

2.10 SECUREMENTS

- A. Bands:

1. Products: Subject to compliance with requirements, provide one of the following:
 - a. ITW Insulation Systems; Gerrard Strapping and Seals.

- b. RPR Products, Inc.; Insul-Mate Strapping, Seals, and Springs.
2. Aluminum: ASTM B 209, Alloy 3003, 3005, 3105, or 5005; Temper H-14, 0.020 inch thick, 3/4 inch wide with wing seal.
3. Springs: Twin spring set constructed of stainless steel with ends flat and slotted to accept metal bands. Spring size determined by manufacturer for application.

B. Insulation Pins and Hangers:

1. Capacitor-Discharge-Weld Pins: Copper- or zinc-coated steel pin, fully annealed for capacitor-discharge welding, 0.135-inch-diameter shank, length to suit depth of insulation indicated.
 - a. Products: Subject to compliance with requirements, provide one of the following:
 - 1) AGM Industries, Inc.; CWP-1.
 - 2) GEMCO; CD.
 - 3) Midwest Fasteners, Inc.; CD.
 - 4) Nelson Stud Welding; TPA, TPC, and TPS.
2. Cupped-Head, Capacitor-Discharge-Weld Pins: Copper- or zinc-coated steel pin, fully annealed for capacitor-discharge welding, 0.135-inch- diameter shank, length to suit depth of insulation indicated with integral 1 to 1-1/2-inch galvanized carbon-steel washer.
 - a. Products: Subject to compliance with requirements, provide one of the following:
 - 1) AGM Industries, Inc.; CHP-1.
 - 2) GEMCO; Cupped Head Weld Pin.
 - 3) Midwest Fasteners, Inc.; Cupped Head.
 - 4) Nelson Stud Welding; CHP.
3. Metal, Adhesively Attached, Perforated-Base Insulation Hangers: Baseplate welded to projecting spindle that is capable of holding insulation, of thickness indicated, securely in position indicated when self-locking washer is in place. Comply with the following requirements:
 - a. Products: Subject to compliance with requirements, provide one of the following:
 - 1) AGM Industries, Inc.; Tactoo Perforated Base Insul-Hangers.
 - 2) GEMCO; Perforated Base.
 - 3) Midwest Fasteners, Inc.; Spindle.
 - b. Baseplate: Perforated, galvanized carbon-steel sheet, 0.030 inch thick by 2 inches square.
 - c. Spindle: Copper- or zinc-coated, low-carbon steel fully annealed, 0.106-inch-diameter shank, length to suit depth of insulation indicated.
 - d. Adhesive: Recommended by hanger manufacturer. Product with demonstrated capability to bond insulation hanger securely to substrates indicated without damaging insulation, hangers, and substrates.
4. Nonmetal, Adhesively Attached, Perforated-Base Insulation Hangers: Baseplate fastened to projecting spindle that is capable of holding insulation, of thickness indicated, securely in position indicated when self-locking washer is in place. Comply with the following requirements:
 - a. Products: Subject to compliance with requirements, provide one of the following:
 - 1) GEMCO; Nylon Hangers.
 - 2) Midwest Fasteners, Inc.; Nylon Insulation Hangers.
 - b. Baseplate: Perforated, nylon sheet, 0.030 inch thick by 1-1/2 inches in diameter.

- c. Spindle: Nylon, 0.106-inch- diameter shank, length to suit depth of insulation indicated, up to 2-1/2 inches.
 - d. Adhesive: Recommended by hanger manufacturer. Product with demonstrated capability to bond insulation hanger securely to substrates indicated without damaging insulation, hangers, and substrates.
5. Self-Sticking-Base Insulation Hangers: Baseplate welded to projecting spindle that is capable of holding insulation, of thickness indicated, securely in position indicated when self-locking washer is in place. Comply with the following requirements:
- a. Products: Subject to compliance with requirements, provide one of the following:
 - 1) AGM Industries, Inc.; Tactoo Self-Adhering Insul-Hangers.
 - 2) GEMCO; Peel & Press.
 - 3) Midwest Fasteners, Inc.; Self Stick.
 - b. Baseplate: Galvanized carbon-steel sheet, 0.030 inch thick by 2 inches square.
 - c. Spindle: Copper- or zinc-coated, low-carbon steel, fully annealed, 0.106-inch-diameter shank, length to suit depth of insulation indicated.
 - d. Adhesive-backed base with a peel-off protective cover.

PART 3 - EXECUTION

3.1 EXAMINATION

- A. Examine substrates and conditions for compliance with requirements for installation tolerances and other conditions affecting performance of insulation application.
 - 1. Verify that systems to be insulated have been tested and are free of defects.
 - 2. Verify that surfaces to be insulated are clean and dry.
- B. Proceed with installation only after unsatisfactory conditions have been corrected.

3.2 PREPARATION

- A. Surface Preparation: Clean and dry surfaces to receive insulation. Remove materials that will adversely affect insulation application.

3.3 GENERAL INSTALLATION REQUIREMENTS

- A. Install insulation materials, accessories, and finishes with smooth, straight, and even surfaces; free of voids throughout the length of ducts and fittings.
- B. Install insulation materials, vapor barriers or retarders, jackets, and thicknesses required for each item of duct system as specified in insulation system schedules.
- C. Install accessories compatible with insulation materials and suitable for the service. Install accessories that do not corrode, soften, or otherwise attack insulation or jacket in either wet or dry state.
- D. Install insulation with longitudinal seams at top and bottom of horizontal runs.
- E. Install multiple layers of insulation with longitudinal and end seams staggered.
- F. Keep insulation materials dry during application and finishing.

- G. Install insulation with tight longitudinal seams and end joints. Bond seams and joints with adhesive recommended by insulation material manufacturer.
- H. Install insulation with least number of joints practical.
- I. Where vapor barrier is indicated, seal joints, seams, and penetrations in insulation at hangers, supports, anchors, and other projections with vapor-barrier mastic.
 - 1. Install insulation continuously through hangers and around anchor attachments.
 - 2. For insulation application where vapor barriers are indicated, extend insulation on anchor legs from point of attachment to supported item to point of attachment to structure. Taper and seal ends at attachment to structure with vapor-barrier mastic.
 - 3. Install insert materials and install insulation to tightly join the insert. Seal insulation to insulation inserts with adhesive or sealing compound recommended by insulation material manufacturer.
- J. Apply adhesives, mastics, and sealants at manufacturer's recommended coverage rate and wet and dry film thicknesses.
- K. Install insulation with factory-applied jackets as follows:
 - 1. Draw jacket tight and smooth.
 - 2. Cover circumferential joints with 3-inch- wide strips, of same material as insulation jacket. Secure strips with adhesive and outward clinching staples along both edges of strip, spaced 4 inches o.c.
 - 3. Overlap jacket longitudinal seams at least 1-1/2 inches. Clean and dry surface to receive self-sealing lap. Staple laps with outward clinching staples along edge at:
 - a. 2 inches o.c.
 - b. For below ambient services, apply vapor-barrier mastic over staples.
 - 4. Cover joints and seams with tape, according to insulation material manufacturer's written instructions, to maintain vapor seal.
 - 5. Where vapor barriers are indicated, apply vapor-barrier mastic on seams and joints and at ends adjacent to duct flanges and fittings.
- L. Cut insulation in a manner to avoid compressing insulation more than 75 percent of its nominal thickness.
- M. Finish installation with systems at operating conditions. Repair joint separations and cracking due to thermal movement.
- N. Repair damaged insulation facings by applying same facing material over damaged areas. Extend patches at least 4 inches beyond damaged areas. Adhere, staple, and seal patches similar to butt joints.

3.4 PENETRATIONS

- A. Insulation Installation at Roof Penetrations: Install insulation continuously through roof penetrations.
 - 1. Seal penetrations with flashing sealant.
 - 2. For applications requiring only indoor insulation, terminate insulation above roof surface and seal with joint sealant. For applications requiring indoor and outdoor insulation, install insulation for outdoor applications tightly joined to indoor insulation ends. Seal joint with joint sealant.
 - 3. Extend jacket of outdoor insulation outside roof flashing at least 2 inches below top of roof flashing.
 - 4. Seal jacket to roof flashing with flashing sealant.

- B. Insulation Installation at Aboveground Exterior Wall Penetrations: Install insulation continuously through wall penetrations.
 - 1. Seal penetrations with flashing sealant.
 - 2. For applications requiring only indoor insulation, terminate insulation inside wall surface and seal with joint sealant. For applications requiring indoor and outdoor insulation, install insulation for outdoor applications tightly joined to indoor insulation ends. Seal joint with joint sealant.
 - 3. Extend jacket of outdoor insulation outside wall flashing and overlap wall flashing at least 2 inches.
 - 4. Seal jacket to wall flashing with flashing sealant.
- C. Insulation Installation at Interior Wall and Partition Penetrations (That Are Not Fire Rated): Install insulation continuously through walls and partitions.
- D. Insulation Installation at Fire-Rated Wall and Partition Penetrations: Terminate insulation at fire damper sleeves for fire-rated wall and partition penetrations. Externally insulate damper sleeves to match adjacent insulation and overlap duct insulation at least 2 inches.
 - 1. Comply with requirements in Section 078413 "Penetration Firestopping" firestopping and fire-resistive joint sealers.
- E. Insulation Installation at Floor Penetrations:
 - 1. Duct: For penetrations through fire-rated assemblies, terminate insulation at fire damper sleeves and externally insulate damper sleeve beyond floor to match adjacent duct insulation. Overlap damper sleeve and duct insulation at least 2 inches.
 - 2. Seal penetrations through fire-rated assemblies. Comply with requirements in Section 078413 "Penetration Firestopping."

3.5 INSTALLATION OF FLEXIBLE ELASTOMERIC INSULATION

- A. Seal longitudinal seams and end joints with manufacturers recommended adhesive to eliminate openings in insulation that allow passage of air to surface being insulated.

3.6 INSTALLATION OF MINERAL-FIBER INSULATION

- A. Blanket Insulation Installation on Ducts and Plenums: Secure with adhesive and insulation pins.
 - 1. Apply adhesives according to manufacturer's recommended coverage rates per unit area, for:
 - a. 100 percent coverage of duct and plenum surfaces.
 - 2. Apply adhesive to entire circumference of ducts and to all surfaces of fittings and transitions.
 - 3. Install either capacitor-discharge-weld pins and speed washers or cupped-head, capacitor-discharge-weld pins on sides and bottom of horizontal ducts and sides of vertical ducts as follows:
 - a. On duct sides with dimensions 18 inches and smaller, place pins along longitudinal centerline of duct. Space 3 inches maximum from insulation end joints, and 16 inches o.c.
 - b. On duct sides with dimensions larger than 18 inches, place pins 16 inches o.c. each way, and 3 inches maximum from insulation joints. Install additional pins to hold insulation tightly against surface at cross bracing.
 - c. Pins may be omitted from top surface of horizontal, rectangular ducts and plenums.
 - d. Do not overcompress insulation during installation.
 - e. Impale insulation over pins and attach speed washers.

- f. Cut excess portion of pins extending beyond speed washers or bend parallel with insulation surface. Cover exposed pins and washers with tape matching insulation facing.
 4. For ducts and plenums with surface temperatures below ambient, install a continuous unbroken vapor barrier. Create a facing lap for longitudinal seams and end joints with insulation by removing 2 inches from one edge and one end of insulation segment. Secure laps to adjacent insulation section with 1/2-inch outward-clinching staples, 1 inch o.c. Install vapor barrier consisting of factory- or field-applied jacket, adhesive, vapor-barrier mastic, and sealant at joints, seams, and protrusions.
 - a. Repair punctures, tears, and penetrations with tape or mastic to maintain vapor-barrier seal.
 - b. Install vapor stops for ductwork and plenums operating below 50 deg F at 18-foot intervals. Vapor stops shall consist of vapor-barrier mastic applied in a Z-shaped pattern over insulation face, along butt end of insulation, and over the surface. Cover insulation face and surface to be insulated a width equal to two times the insulation thickness, but not less than 3 inches.
 5. Overlap unfaced blankets a minimum of 2 inches on longitudinal seams and end joints. At end joints, secure with steel bands spaced a maximum of 18 inches o.c.
 6. Install insulation on rectangular duct elbows and transitions with a full insulation section for each surface. Install insulation on round and flat-oval duct elbows with individually mitered gores cut to fit the elbow.
 7. Insulate duct stiffeners, hangers, and flanges that protrude beyond insulation surface with 6-inch- wide strips of same material used to insulate duct. Secure on alternating sides of stiffener, hanger, and flange with pins spaced 6 inches o.c.
- B. Board Insulation Installation on Ducts and Plenums: Secure with adhesive and insulation pins.
1. Apply adhesives according to manufacturer's recommended coverage rates per unit area, for:
 - a. 50 percent coverage of duct and plenum surfaces.
 2. Apply adhesive to entire circumference of ducts and to all surfaces of fittings and transitions.
 3. Install either capacitor-discharge-weld pins and speed washers or cupped-head, capacitor-discharge-weld pins on sides and bottom of horizontal ducts and sides of vertical ducts as follows:
 - a. On duct sides with dimensions 18 inches and smaller, place pins along longitudinal centerline of duct. Space 3 inches maximum from insulation end joints, and 16 inches o.c.
 - b. On duct sides with dimensions larger than 18 inches, space pins 16 inches o.c. each way, and 3 inches maximum from insulation joints. Install additional pins to hold insulation tightly against surface at cross bracing.
 - c. Pins may be omitted from top surface of horizontal, rectangular ducts and plenums.
 - d. Do not overcompress insulation during installation.
 - e. Cut excess portion of pins extending beyond speed washers or bend parallel with insulation surface. Cover exposed pins and washers with tape matching insulation facing.
 4. For ducts and plenums with surface temperatures below ambient, install a continuous unbroken vapor barrier. Create a facing lap for longitudinal seams and end joints with insulation by removing 2 inches from one edge and one end of insulation segment. Secure laps to adjacent insulation section with 1/2-inch outward-clinching staples, 1 inch o.c. Install vapor barrier consisting of factory- or field-applied jacket, adhesive, vapor-barrier mastic, and sealant at joints, seams, and protrusions.

- a. Repair punctures, tears, and penetrations with tape or mastic to maintain vapor-barrier seal.
5. Install insulation on rectangular duct elbows and transitions with a full insulation section for each surface. Groove and score insulation to fit as closely as possible to outside and inside radius of elbows. Install insulation on round and flat-oval duct elbows with individually mitered gores cut to fit the elbow.
6. Insulate duct stiffeners, hangers, and flanges that protrude beyond insulation surface with 6-inch- wide strips of same material used to insulate duct. Secure on alternating sides of stiffener, hanger, and flange with pins spaced 6 inches o.c.

3.7 FIELD-APPLIED JACKET INSTALLATION

- A. Where glass-cloth jackets are indicated, install directly over bare insulation or insulation with factory-applied jackets.
 1. Draw jacket smooth and tight to surface with 2-inch overlap at seams and joints.
 2. Embed glass cloth between two 0.062-inch- thick coats of lagging adhesive.
 3. Completely encapsulate insulation with coating, leaving no exposed insulation.
- B. Where FSK jackets are indicated, install as follows:
 1. Draw jacket material smooth and tight.
 2. Install lap or joint strips with same material as jacket.
 3. Secure jacket to insulation with manufacturer's recommended adhesive.
 4. Install jacket with 1-1/2-inch laps at longitudinal seams and 3-inch- wide joint strips at end joints.
 5. Seal openings, punctures, and breaks in vapor-retarder jackets and exposed insulation with vapor-barrier mastic.
- C. Where PVC jackets are indicated, install with 1-inch overlap at longitudinal seams and end joints; for horizontal applications, install with longitudinal seams along top and bottom of tanks and vessels. Seal with manufacturers recommended adhesive.
 1. Apply two continuous beads of adhesive to seams and joints, one bead under lap and the finish bead along seam and joint edge.
- D. Where metal jackets are indicated, install with 2-inch overlap at longitudinal seams and end joints. Overlap longitudinal seams arranged to shed water. Seal end joints with weatherproof sealant recommended by insulation manufacturer. Secure jacket with stainless-steel bands 12 inches o.c. and at end joints.

3.8 FIRE-RATED INSULATION SYSTEM INSTALLATION

- A. Where fire-rated insulation system is indicated, secure system to ducts and duct hangers and supports to maintain a continuous fire rating.
- B. Insulate duct access panels and doors to achieve same fire rating as duct.
- C. Install firestopping at penetrations through fire-rated assemblies. Fire-stop systems are specified in Division 07 Section "Penetration Firestopping."

3.9 FINISHES

- A. Insulation with ASJ, Glass-Cloth, or Other Paintable Jacket Material: Paint jacket with paint system identified below and as specified in Division 09 Section "Exterior Painting" and "Interior Painting."

1. Flat Acrylic Finish: Two finish coats over a primer that is compatible with jacket material and finish coat paint. Add fungicidal agent to render fabric mildew proof.
 - a. Finish Coat Material: Interior, flat, latex-emulsion size.
- B. Flexible Elastomeric Thermal Insulation: After adhesive has fully cured, apply two coats of insulation manufacturer's recommended protective coating.
- C. Color: Final color as selected by Architect. Vary first and second coats to allow visual inspection of the completed Work.
- D. Do not field paint aluminum or stainless-steel jackets.

3.10 FIELD QUALITY CONTROL

- A. Testing Agency:
 - a. Engage a qualified testing agency to perform tests and inspections.
- B. Perform tests and inspections.
- C. Tests and Inspections:
 1. Inspect ductwork, randomly selected by Architect, by removing field-applied jacket and insulation in layers in reverse order of their installation. Extent of inspection shall be limited to one location (s) for each duct system defined in the "Duct Insulation Schedule, General" Article.
- D. All insulation applications will be considered defective Work if sample inspection reveals noncompliance with requirements.

3.11 DUCT INSULATION SCHEDULE, GENERAL

- A. Plenums and Ducts Requiring Insulation:
 1. Indoor, concealed supply and outdoor air.
 2. Indoor, exposed supply and outdoor air.
 3. Indoor, concealed return located in unconditioned space.
 4. Indoor, exposed return located in unconditioned space.
 5. Outdoor, concealed supply and return.
 6. Outdoor, exposed supply and return.
- B. Items Not Insulated:
 1. Fibrous-glass ducts.
 2. Metal ducts with duct liner of sufficient thickness to comply with energy code and ASHRAE/IESNA 90.1.
 3. Factory-insulated flexible ducts.
 4. Factory-insulated plenums and casings.
 5. Flexible connectors.
 6. Vibration-control devices.
 7. Factory-insulated access panels and doors.

3.12 Insulation shall have an R value that meets the minimum requirements of the latest International Energy Conservation Code (IECC).

3.13 INDOOR DUCT AND PLENUM INSULATION SCHEDULE

- A. Concealed, round and flat-oval, supply-air duct insulation shall be one of the following:
 - 1. Flexible Elastomeric: 1 inch thick.
 - 2. Mineral-Fiber Blanket: 1 inch thick and 0.75-lb/cu. ft. nominal density.
- B. Concealed, round and flat-oval, return-air duct insulation shall be one of the following:
 - 1. Flexible Elastomeric: 1 inch thick.
 - 2. Mineral-Fiber Blanket: 1 inch thick and 0.75-lb/cu. ft. nominal density.
- C. Concealed, round and flat-oval, outdoor-air and combustion-air duct insulation shall be one of the following:
 - 1. Flexible Elastomeric: 1 inch thick.
 - 2. Mineral-Fiber Blanket: 1 inch thick and 0.75-lb/cu. ft. nominal density.
- D. Concealed, round and flat-oval, exhaust-air duct insulation shall be one of the following:
 - 1. Flexible Elastomeric: 1 inch thick.
 - 2. Mineral-Fiber Blanket: 1 inch thick and 0.75-lb/cu. ft. nominal density.
- E. Concealed, rectangular, supply-air duct insulation shall be one of the following:
 - 1. Flexible Elastomeric: 1 inch thick.
 - 2. Mineral-Fiber Blanket: 1 inch thick and 0.75-lb/cu. ft. nominal density.
- F. Concealed, rectangular, return-air duct insulation shall be one of the following:
 - 1. Flexible Elastomeric: 1 inch thick.
 - 2. Mineral-Fiber Blanket: 1 inch thick and 0.75-lb/cu. ft. nominal density.
- G. Concealed, rectangular, outdoor-air and combustion-air duct insulation shall be one of the following:
 - 1. Flexible Elastomeric: 1 inch thick.
 - 2. Mineral-Fiber Blanket: 1 inch thick and 0.75-lb/cu. ft. nominal density.
- H. Concealed, supply-air plenum insulation shall be one of the following:
 - 1. Flexible Elastomeric: 1 inch thick.
 - 2. Mineral-Fiber Blanket: 1 inch thick and 0.75-lb/cu. ft. nominal density.
- I. Concealed, return-air plenum insulation shall be one of the following:
 - 1. Flexible Elastomeric: 1 inch thick.
 - 2. Mineral-Fiber Blanket: 1 inch thick and 0.75-lb/cu. ft. nominal density.
- J. Concealed, outdoor-air plenum insulation shall be one of the following:
 - 1. Flexible Elastomeric: 1 inch thick.
 - 2. Mineral-Fiber Blanket: 1 inch thick and 0.75-lb/cu. ft. nominal density.
- K. Exposed, round and flat-oval, supply-air duct insulation shall be one of the following:

1. Flexible Elastomeric: 1 inch thick.
 2. Mineral-Fiber Blanket: 1 inch thick and 0.75-lb/cu. ft. nominal density.
- L. Exposed, round and flat-oval, return-air duct insulation shall be one of the following:
1. Flexible Elastomeric: 1 inch thick.
- M. Exposed, round and flat-oval, outdoor-air and combustion-air duct insulation shall be one of the following:
1. Flexible Elastomeric: 1 inch thick.
 2. Mineral-Fiber Blanket: 1 inch thick and 0.75-lb/cu. ft. nominal density.
- N. Exposed, rectangular, supply-air duct insulation shall be one of the following:
1. Flexible Elastomeric: 1 inch thick.
 2. Mineral-Fiber Blanket: 1 inch thick and 0.75-lb/cu. ft. nominal density.
- O. Exposed, rectangular, return-air duct insulation shall be one of the following:
1. Flexible Elastomeric: 1 inch thick.
 2. Mineral-Fiber Blanket: 1 inch thick and 0.75-lb/cu. ft. nominal density.
- P. Exposed, rectangular, outdoor-air and combustion-air duct insulation shall be one of the following:
1. Flexible Elastomeric: 1 inch thick.
 2. Mineral-Fiber Blanket: 1 inch thick and 0.75-lb/cu. ft. nominal density.
- Q. Exposed, supply-air plenum insulation shall be one of the following:
1. Flexible Elastomeric: 1 inch thick.
 2. Mineral-Fiber Blanket: 1 inch thick and 0.75-lb/cu. ft. nominal density.
- R. Exposed, return-air plenum insulation shall be one of the following:
1. Flexible Elastomeric: 1 inch thick.
 2. Mineral-Fiber Blanket: 1 inch thick and 0.75-lb/cu. ft. nominal density.

3.14 UNCONDITIONED SPACE AND BURIED DUCT INSULATION SCHEDULE

- A. Insulation materials and thicknesses are identified below. If more than one material is listed for a duct system, selection from materials listed is Contractor's option.
- B. Concealed, round and flat-oval, supply-air duct insulation shall be one of the following:
1. Flexible Elastomeric: 1.5 inches thick.
 2. Mineral-Fiber Blanket: 2 inches thick and 0.75-lb/cu. ft. nominal density.
 3. Polyolefin: 1.5 inches thick.
- C. Concealed, round and flat-oval, return-air duct insulation shall be one of the following:
1. Flexible Elastomeric: 1.5 inches thick.
 2. Mineral-Fiber Blanket: 2 inches thick and 0.75-lb/cu. ft. nominal density.
 3. Polyolefin: 1.5 inches thick.
- D. Concealed, round and flat-oval, outdoor-air and combustion-air duct insulation shall be one of the following:

1. Flexible Elastomeric: 1.5 inches thick.
 2. Mineral-Fiber Blanket: 2 inches thick and 0.75-lb/cu. ft. nominal density.
 3. Polyolefin: 1.5 inches thick.
- E. Concealed, round and flat-oval, exhaust-air duct insulation shall be one of the following:
1. Flexible Elastomeric: 1.5 inches thick.
 2. Mineral-Fiber Blanket: 2 inches thick and 0.75-lb/cu. ft. nominal density.
 3. Polyolefin: 1.5 inches thick.
- F. Concealed, rectangular, supply-air duct insulation shall be one of the following:
1. Flexible Elastomeric: 1.5 inches thick.
 2. Mineral-Fiber Blanket: 2 inches thick and 0.75-lb/cu. ft. nominal density.
 3. Polyolefin: 1.5 inches thick.
- G. Concealed, rectangular, return-air duct insulation shall be one of the following:
1. Flexible Elastomeric: 1.5 inches thick.
 2. Mineral-Fiber Blanket: 2 inches thick and 0.75-lb/cu. ft. nominal density.
 3. Polyolefin: 1.5 inches thick.
- H. Concealed, rectangular, outdoor-air and combustion-air duct insulation shall be one of the following:
1. Flexible Elastomeric: 1.5 inches thick.
 2. Mineral-Fiber Blanket: 2 inches thick and 0.75-lb/cu. ft. nominal density.
 3. Polyolefin: 1.5 inches thick.

3.15 ABOVEGROUND, OUTDOOR DUCT AND PLENUM INSULATION SCHEDULE

- A. Insulation materials and thicknesses are identified below. If more than one material is listed for a duct system, selection from materials listed is Contractor's option.
- B. Exposed, round and flat-oval, supply-air duct insulation shall be one of the following:
1. Flexible Elastomeric: 3 inches thick.
 2. Polyolefin: 3 inches thick.
- C. Exposed, round and flat-oval, return-air duct insulation shall be one of the following:
1. Flexible Elastomeric: 3 inches thick.
 2. Polyolefin: 3 inches thick.
- D. Exposed, rectangular, supply-air duct insulation shall be one of the following:
1. Flexible Elastomeric: 3 inches thick.
 2. Polyolefin: 3 inches thick.
- E. Exposed, rectangular, return-air duct insulation shall be one of the following:
1. Flexible Elastomeric: 3 inches thick.
 2. Polyolefin: 3 inches thick.
- F. Exposed, supply-air plenum insulation shall be one of the following:
1. Flexible Elastomeric: 3 inches thick.
 2. Polyolefin: 3 inches thick.

G. Exposed, return-air plenum insulation shall be one of the following:

1. Flexible Elastomeric: 3 inches thick.
2. Polyolefin: 3 inches thick.

3.16 OUTDOOR, FIELD-APPLIED JACKET SCHEDULE

- A. Install jacket over insulation material. For insulation with factory-applied jacket, install the field-applied jacket over the factory-applied jacket.
- B. If more than one material is listed, selection from materials listed is Contractor's option.
- C. Ducts and Plenums, Concealed:
1. Aluminum, Corrugated: 0.032 inch thick.
- D. Ducts and Plenums, Exposed, up to 48 Inches in Diameter or with Flat Surfaces up to 72 Inches:
1. Aluminum, Corrugated: 0.032 inch thick.
- E. Ducts and Plenums, Exposed, Larger Than 48 Inches in Diameter or with Flat Surfaces Larger Than 72 Inches:
1. Aluminum, with 1-1/4-Inch- Deep Corrugations: 0.032 inch thick.

END OF SECTION 23 0713

SECTION 23 0719

HVAC PIPING INSULATION

PART 1 - GENERAL

1.1 RELATED DOCUMENTS

- A. Drawings and general provisions of the Contract, including General and Supplementary Conditions and Division 01 Specification Sections, apply to this Section.

1.2 SUMMARY

- A. Section includes insulating the following HVAC piping systems:
 - 1. Condensate drain piping.
 - 2. Chilled-water piping.
 - 3. Condenser-water piping.
 - 4. Heating hot-water piping.
 - 5. Steam and steam condensate piping.
 - 6. Refrigerant suction and hot-gas piping.

- B. Related Sections:

- 1. Division 23 Section "Duct Insulation."
- 2. Division 23 Section "HVAC Equipment Insulation."

1.3 DEFINITIONS:

- A. Refer to Division 23 Section "Common Work Results for HVAC".

1.4 ACTION SUBMITTALS

- A. Product Data: For each type of product indicated. Include thermal conductivity, water-vapor permeance thickness, and jackets (both factory and field applied if any).

- B. LEED Submittals:

- 1. Product Data for Credit IEQ 4.1: For adhesives and sealants, documentation including printed statement of VOC content.
- 2. Laboratory Test Reports for Credit IEQ 4: For adhesives and sealants, documentation indicating that products comply with the testing and product requirements of the California Department of Health Services' "Standard Practice for the Testing of Volatile Organic Emissions from Various Sources Using Small-Scale Environmental Chambers."

- C. Shop Drawings: Include plans, elevations, sections, details, and attachments to other work.

- 1. Detail application of protective shields, saddles, and inserts at hangers for each type of insulation and hanger.
- 2. Detail attachment and covering of heat tracing inside insulation.
- 3. Detail insulation application at pipe expansion joints for each type of insulation.
- 4. Detail insulation application at elbows, fittings, flanges, valves, and specialties for each type of insulation.
- 5. Detail removable insulation at piping specialties.

6. Detail application of field-applied jackets.
7. Detail application at linkages of control devices.

1.5 INFORMATIONAL SUBMITTALS

- A. Qualification Data: For qualified Installer.
- B. Material Test Reports: From a qualified testing agency acceptable to authorities having jurisdiction indicating, interpreting, and certifying test results for compliance of insulation materials, sealers, attachments, cements, and jackets, with requirements indicated. Include dates of tests and test methods employed.

1.6 QUALITY ASSURANCE

- A. Installer Qualifications: Skilled mechanics who have successfully completed an apprenticeship program or another craft training program certified by the Department of Labor, Bureau of Apprenticeship and Training.
- B. Surface-Burning Characteristics: For insulation and related materials, as determined by testing identical products according to ASTM E 84, by a testing and inspecting agency acceptable to authorities having jurisdiction. Factory label insulation and jacket materials and adhesive, mastic, tapes, and cement material containers, with appropriate markings of applicable testing agency.
 1. Insulation Installed Indoors: Flame-spread index of 25 or less, and smoke-developed index of 50 or less.
 2. Insulation Installed Outdoors: Flame-spread index of 75 or less, and smoke-developed index of 150 or less.

1.7 DELIVERY, STORAGE, AND HANDLING

- A. Packaging: Insulation material containers shall be marked by manufacturer with appropriate ASTM standard designation, type and grade, and maximum use temperature.

1.8 COORDINATION

- A. Coordinate sizes and locations of supports, hangers, and insulation shields specified in Division 23 Section "Hangers and Supports for HVAC Piping and Equipment."
- B. Coordinate clearance requirements with piping Installer for piping insulation application. Before preparing piping Shop Drawings, establish and maintain clearance requirements for installation of insulation and field-applied jackets and finishes and for space required for maintenance.

1.9 SCHEDULING

- A. Schedule insulation application after pressure testing systems and, where required, after installing and testing heat tracing. Insulation application may begin on segments that have satisfactory test results.
- B. Complete installation and concealment of plastic materials as rapidly as possible in each area of construction.

PART 2 - PRODUCTS

2.1 INSULATION MATERIALS

- A. Comply with requirements in "Piping Insulation Schedule, General," "Indoor Piping Insulation Schedule," "Outdoor, Aboveground Piping Insulation Schedule," and "Outdoor, Underground Piping Insulation Schedule" articles for where insulating materials shall be applied.
- B. Insulation for below-ambient service requires a vapor-barrier.
- C. Products shall not contain asbestos, lead, mercury, or mercury compounds.
- D. Products that come in contact with stainless steel shall have a leachable chloride content of less than 50 ppm when tested according to ASTM C 871.
- E. Insulation materials for use on austenitic stainless steel shall be qualified as acceptable according to ASTM C 795.
- F. Foam insulation materials shall not use CFC or HCFC blowing agents in the manufacturing process.
- G. Calcium Silicate:
 - 1. Products: Subject to compliance with requirements, provide the following:
 - a. Industrial Insulation Group (IIG); Thermo-12 Gold.
 - 2. Preformed Pipe Sections: Flat-, curved-, and grooved-block sections of noncombustible, inorganic, hydrous calcium silicate with a non-asbestos fibrous reinforcement. Comply with ASTM C 533, Type I.
 - 3. Flat-, curved-, and grooved-block sections of noncombustible, inorganic, hydrous calcium silicate with a non-asbestos fibrous reinforcement. Comply with ASTM C 533, Type I.
 - 4. Prefabricated Fitting Covers: Comply with ASTM C 450 and ASTM C 585 for dimensions used in preforming insulation to cover valves, elbows, tees, and flanges.
- H. Flexible Elastomeric Insulation: Closed-cell, sponge- or expanded-rubber materials. Comply with ASTM C 534, Type I for tubular materials.
 - 1. Products: Subject to compliance with requirements, provide one of the following:
 - a. Aeroflex USA, Inc.; Aerocel.
 - b. Armacell LLC; AP Armaflex.
 - c. K-Flex USA; Insul-Lock, Insul-Tube, and K-FLEX LS.
- I. Mineral-Fiber Blanket Insulation: Mineral or glass fibers bonded with a thermosetting resin. Comply with ASTM C 553,
 - 1. Type II and ASTM C 1290, Factory-applied jacket requirements are specified in "Factory-Applied Jackets" Article.
 - 2. Products: Subject to compliance with requirements, provide one of the following:
 - a. CertainTeed Corp.; SoftTouch Duct Wrap.
 - b. Johns Manville; Microlite.
 - c. Knauf Insulation; Friendly Feel Duct Wrap.
 - d. Manson Insulation Inc.; Alley Wrap.
 - e. Owens Corning; SOFTR All-Service Duct Wrap.
- J. Mineral-Fiber, Preformed Pipe Insulation:

1. Products: Subject to compliance with requirements, provide one of the following:
 - a. Johns Manville; Micro-Lok.
 - b. Knauf Insulation; 1000-Degree Pipe Insulation.
 - c. Manson Insulation Inc.; Alley-K.
 - d. Owens Corning; Fiberglas Pipe Insulation.
 - e. Type I, 850 deg F Materials: Mineral or glass fibers bonded with a thermosetting resin. Comply with ASTM C 547, Type I, Grade A:
 - 1) with factory-applied ASJ-SSL. Factory-applied jacket requirements are specified in "Factory-Applied Jackets" Article.

- K. Mineral-Fiber, Pipe and Tank Insulation: Mineral or glass fibers bonded with a thermosetting resin. Semirigid board material with factory-applied:
 1. ASJ complying with ASTM C 1393, Type II or Type IIIA Category 2, or with properties similar to ASTM C 612, Type IB. Nominal density is 2.5 lb/cu. ft. or more. Thermal conductivity (k-value) at 100 deg F is 0.29 Btu x in./h x sq. ft. x deg F or less. Factory-applied jacket requirements are specified in "Factory-Applied Jackets" Article.

2. Products: Subject to compliance with requirements, provide one of the following:
 - a. CertainTeed Corp.; CrimpWrap.
 - b. Johns Manville; MicroFlex.
 - c. Knauf Insulation; Pipe and Tank Insulation.
 - d. Manson Insulation Inc.; AK Flex.
 - e. Owens Corning; Fiberglas Pipe and Tank Insulation.

- L. Prefabricated Thermal Insulating Fitting Covers: Comply with ASTM C 450 for dimensions used in preforming insulation to cover valves, elbows, tees, and flanges.

2.2 INSULATING CEMENTS

- A. Mineral-Fiber Insulating Cement: Comply with ASTM C 195.
 1. Products: Subject to compliance with requirements, provide the following:
 - a. Ramco Insulation, Inc.; Super-Stik.

- B. Mineral-Fiber, Hydraulic-Setting Insulating and Finishing Cement: Comply with ASTM C 449.
 1. Products: Subject to compliance with requirements, provide the following:
 - a. Ramco Insulation, Inc.; Ramcote 1200 and Quik-Cote.

2.3 ADHESIVES

- A. Materials shall be compatible with insulation materials, jackets, and substrates and for bonding insulation to itself and to surfaces to be insulated unless otherwise indicated.

- B. Calcium Silicate Adhesive: Fibrous, sodium-silicate-based adhesive with a service temperature range of 50 to 800 deg F.
 1. Products: Subject to compliance with requirements, provide one of the following:
 - a. Childers Brand, Specialty Construction Brands, Inc., a business of H. B. Fuller Company; CP-97.
 - b. Eagle Bridges - Marathon Industries; 290.
 - c. Foster Brand, Specialty Construction Brands, Inc., a business of H. B. Fuller Company; 81-27.

- d. Mon-Eco Industries, Inc.; 22-30.
 - e. Vimasco Corporation; 760.
2. For indoor applications, adhesive shall have a VOC content of 80 g/L or less when calculated according to 40 CFR 59, Subpart D (EPA Method 24).
 3. Adhesive shall comply with the testing and product requirements of the California Department of Health Services' "Standard Practice for the Testing of Volatile Organic Emissions from Various Sources Using Small-Scale Environmental Chambers."
- C. Flexible Elastomeric Adhesive: Comply with MIL-A-24179A, Type II, Class I.
1. Products: Subject to compliance with requirements, provide one of the following:
 - a. Aeroflex USA, Inc.; Aero seal.
 - b. Armacell LLC; Armaflex 520 Adhesive.
 - c. Foster Brand, Specialty Construction Brands, Inc., a business of H. B. Fuller Company; 85-75.
 - d. K-Flex USA; R-373 Contact Adhesive.
 2. For indoor applications, adhesive shall have a VOC content of 50 g/L or less when calculated according to 40 CFR 59, Subpart D (EPA Method 24).
 3. Adhesive shall comply with the testing and product requirements of the California Department of Health Services' "Standard Practice for the Testing of Volatile Organic Emissions from Various Sources Using Small-Scale Environmental Chambers."
- D. Mineral-Fiber Adhesive: Comply with MIL-A-3316C, Class 2, Grade A.
1. Products: Subject to compliance with requirements, provide one of the following:
 - a. Childers Brand, Specialty Construction Brands, Inc., a business of H. B. Fuller Company; CP-127.
 - b. Eagle Bridges - Marathon Industries; 225.
 - c. Foster Brand, Specialty Construction Brands, Inc., a business of H. B. Fuller Company; 85-60/85-70.
 - d. Mon-Eco Industries, Inc.; 22-25.
 2. For indoor applications, adhesive shall have a VOC content of 80 g/L or less when calculated according to 40 CFR 59, Subpart D (EPA Method 24).
 3. Adhesive shall comply with the testing and product requirements of the California Department of Health Services' "Standard Practice for the Testing of Volatile Organic Emissions from Various Sources Using Small-Scale Environmental Chambers."
- E. ASJ Adhesive, and FSK Jacket Adhesive: Comply with MIL-A-3316C, Class 2, Grade A for bonding insulation jacket lap seams and joints.
1. Products: Subject to compliance with requirements, provide one of the following:
 - a. Childers Brand, Specialty Construction Brands, Inc., a business of H. B. Fuller Company; CP-82.
 - b. Eagle Bridges - Marathon Industries; 225.
 - c. Foster Brand, Specialty Construction Brands, Inc., a business of H. B. Fuller Company; 85-50.
 - d. Mon-Eco Industries, Inc.; 22-25.
 2. For indoor applications, adhesive shall have a VOC content of 50 g/L or less when calculated according to 40 CFR 59, Subpart D (EPA Method 24).
- F. PVC Jacket Adhesive: Compatible with PVC jacket.
1. Products: Subject to compliance with requirements, provide one of the following:

- a. Dow Corning Corporation; 739, Dow Silicone.
 - b. Johns Manville; Zeston Perma-Weld, CEEL-TITE Solvent Welding Adhesive.
 - c. P.I.C. Plastics, Inc.; Welding Adhesive.
 - d. Speedline Corporation; Polyco VP Adhesive.
2. For indoor applications, adhesive shall have a VOC content of 50 g/L or less when calculated according to 40 CFR 59, Subpart D (EPA Method 24).
 3. Adhesive shall comply with the testing and product requirements of the California Department of Health Services' "Standard Practice for the Testing of Volatile Organic Emissions from Various Sources Using Small-Scale Environmental Chambers."

2.4 MASTICS

- A. Materials shall be compatible with insulation materials, jackets, and substrates; comply with MIL-PRF-19565C, Type II.
 1. For indoor applications, use mastics that have a VOC content of 50 g/L or less when calculated according to 40 CFR 59, Subpart D (EPA Method 24).
- B. Vapor-Barrier Mastic: Water based; suitable for indoor use on below-ambient services.
 1. Products: Subject to compliance with requirements, provide one of the following:
 - a. Foster Brand, Specialty Construction Brands, Inc., a business of H. B. Fuller Company; 30-80/30-90.
 - b. Vimasco Corporation; 749.
 2. Water-Vapor Permeance: ASTM E 96/E 96M, Procedure B, 0.013 perm at 43-mil dry film thickness.
 3. Service Temperature Range: Minus 20 to plus 180 deg F.
 4. Solids Content: ASTM D 1644, 58 percent by volume and 70 percent by weight.
 5. Color: White.
- C. Vapor-Barrier Mastic: Solvent based; suitable for outdoor use on below-ambient services.
 1. Products: Subject to compliance with requirements, provide one of the following:
 - a. Childers Brand, Specialty Construction Brands, Inc., a business of H. B. Fuller Company; Encacel.
 - b. Eagle Bridges - Marathon Industries; 570.
 - c. Foster Brand, Specialty Construction Brands, Inc., a business of H. B. Fuller Company; 60-95/60-96.
 2. Water-Vapor Permeance: ASTM F 1249, 0.05 perm at 30-mil dry film thickness.
 3. Service Temperature Range: Minus 50 to plus 220 deg F.
 4. Solids Content: ASTM D 1644, 33 percent by volume and 46 percent by weight.
 5. Color: White.
- D. Breather Mastic: Water based; suitable for indoor and outdoor use on above-ambient services.
 1. Products: Subject to compliance with requirements, provide one of the following:
 - a. Childers Brand, Specialty Construction Brands, Inc., a business of H. B. Fuller Company; CP-10.
 - b. Eagle Bridges - Marathon Industries; 550.
 - c. Foster Brand, Specialty Construction Brands, Inc., a business of H. B. Fuller Company; 46-50.
 - d. Mon-Eco Industries, Inc.; 55-50.
 - e. Vimasco Corporation; WC-1/WC-5.

2. Water-Vapor Permeance: ASTM F 1249, 1.8 perms at 0.0625-inch dry film thickness.
3. Service Temperature Range: Minus 20 to plus 180 deg F.
4. Solids Content: 60 percent by volume and 66 percent by weight.
5. Color: White.

2.5 SEALANTS

A. ASJ Flashing Sealants and PVC Jacket Flashing Sealants:

1. Products: Subject to compliance with requirements, provide the following:
 - a. Childers Brand, Specialty Construction Brands, Inc., a business of H. B. Fuller Company; CP-76.
2. Materials shall be compatible with insulation materials, jackets, and substrates.
3. Fire- and water-resistant, flexible, elastomeric sealant.
4. Service Temperature Range: Minus 40 to plus 250 deg F.
5. Color: White.
6. For indoor applications, sealants shall have a VOC content of 420 g/L or less when calculated according to 40 CFR 59, Subpart D (EPA Method 24).
7. Sealants shall comply with the testing and product requirements of the California Department of Health Services' "Standard Practice for the Testing of Volatile Organic Emissions from Various Sources Using Small-Scale Environmental Chambers."

2.6 FACTORY-APPLIED JACKETS

A. Insulation system schedules indicate factory-applied jackets on various applications. When factory-applied jackets are indicated, comply with the following:

1. ASJ-SSL: ASJ with self-sealing, pressure-sensitive, acrylic-based adhesive covered by a removable protective strip; complying with ASTM C 1136, Type I.

2.7 FIELD-APPLIED JACKETS

A. Field-applied jackets shall comply with ASTM C 921, Type I, unless otherwise indicated.

B. PVC Jacket: High-impact-resistant, UV-resistant PVC complying with ASTM D 1784, Class 16354-C; thickness as scheduled; roll stock ready for shop or field cutting and forming. Thickness is indicated in field-applied jacket schedules.

1. Products: Subject to compliance with requirements, provide one of the following:
 - a. Johns Manville; Zeston.
 - b. P.I.C. Plastics, Inc.; FG Series.
 - c. Proto Corporation; LoSmoke.
 - d. Speedline Corporation; SmokeSafe.
2. Adhesive: As recommended by jacket material manufacturer.
3. Color: PVC, white: 30 mils thick.
4. Factory-fabricated fitting covers to match jacket if available; otherwise, field fabricate.
 - a. Shapes: 45- and 90-degree, short- and long-radius elbows, tees, valves, flanges, unions, reducers, end caps, soil-pipe hubs, traps, mechanical joints, and P-trap and supply covers for lavatories.

C. Metal Jacket:

1. Products: Subject to compliance with requirements, provide one of the following:
 - a. Childers Brand, Specialty Construction Brands, Inc., a business of H. B. Fuller Company; Metal Jacketing Systems.
 - b. ITW Insulation Systems; Aluminum and Stainless Steel Jacketing.
 - c. RPR Products, Inc.; Insul-Mate.

2. Aluminum Jacket: Comply with ASTM B 209, Alloy 3003, 3005, 3105, or 5005, Temper H-14.
 - a. Sheet and roll stock ready for shop or field sizing or factory cut and rolled to size.
 - b. Finish and thickness are indicated in field-applied jacket schedules.
 - c. Moisture Barrier for Indoor Applications:
 - 1) 1-mil- thick, heat-bonded polyethylene and kraft paper.
 - d. Moisture Barrier for Outdoor Applications:
 - 1) 3-mil- thick, heat-bonded polyethylene and kraft paper.
 - e. Factory-Fabricated Fitting Covers:
 - 1) Same material, finish, and thickness as jacket.
 - 2) Preformed 2-piece or gore, 45- and 90-degree, short- and long-radius elbows.
 - 3) Tee covers.
 - 4) Flange and union covers.
 - 5) End caps.
 - 6) Beveled collars.
 - 7) Valve covers.
 - 8) Field fabricate fitting covers only if factory-fabricated fitting covers are not available.

2.8 TAPES

- A. ASJ Tape: White vapor-retarder tape matching factory-applied jacket with acrylic adhesive, complying with ASTM C 1136.
 1. Products: Subject to compliance with requirements, provide one of the following:
 - a. ABI, Ideal Tape Division; 428 AWF ASJ.
 - b. Avery Dennison Corporation, Specialty Tapes Division; Fasson 0836.
 - c. Compac Corporation; 104 and 105.
 - d. Venture Tape; 1540 CW Plus, 1542 CW Plus, and 1542 CW Plus/SQ.
 2. Width: 3 inches.
 3. Thickness: 11.5 mils.
 4. Adhesion: 90 ounces force/inch in width.
 5. Elongation: 2 percent.
 6. Tensile Strength: 40 lbf/inch in width.
 7. ASJ Tape Disks and Squares: Precut disks or squares of ASJ tape.

- B. PVC Tape: White vapor-retarder tape matching field-applied PVC jacket with acrylic adhesive; suitable for indoor and outdoor applications.
 1. Products: Subject to compliance with requirements, provide one of the following:
 - a. ABI, Ideal Tape Division; 370 White PVC tape.
 - b. Compac Corporation; 130.
 - c. Venture Tape; 1506 CW NS.
 2. Width: 2 inches.
 3. Thickness: 6 mils.

4. Adhesion: 64 ounces force/inch in width.
5. Elongation: 500 percent.
6. Tensile Strength: 18 lbf/inch in width.

C. Aluminum-Foil Tape: Vapor-retarder tape with acrylic adhesive.

1. Products: Subject to compliance with requirements, provide one of the following:
 - a. ABI, Ideal Tape Division; 488 AWF.
 - b. Avery Dennison Corporation, Specialty Tapes Division; Fasson 0800.
 - c. Compac Corporation; 120.
 - d. Venture Tape; 3520 CW.
2. Width: 2 inches.
3. Thickness: 3.7 mils.
4. Adhesion: 100 ounces force/inch in width.
5. Elongation: 5 percent.
6. Tensile Strength: 34 lbf/inch in width.

2.9 SECUREMENTS

A. Staples: Outward-clinching insulation staples, nominal 3/4-inch- wide, stainless steel or Monel.

PART 3 - EXECUTION

3.1 EXAMINATION

- A. Examine substrates and conditions for compliance with requirements for installation tolerances and other conditions affecting performance of insulation application.
1. Verify that systems to be insulated have been tested and are free of defects.
 2. Verify that surfaces to be insulated are clean and dry.
 3. Proceed with installation only after unsatisfactory conditions have been corrected.

3.2 PREPARATION

- A. Surface Preparation: Clean and dry surfaces to receive insulation. Remove materials that will adversely affect insulation application.
- B. Surface Preparation: Clean and prepare surfaces to be insulated. Before insulating, apply a corrosion coating to insulated surfaces as follows:
1. Stainless Steel: Coat 300 series stainless steel with an epoxy primer 5 mils thick and an epoxy finish 5 mils thick if operating in a temperature range between 140 and 300 deg F. Consult coating manufacturer for appropriate coating materials and application methods for operating temperature range.
 2. Carbon Steel: Coat carbon steel operating at a service temperature between 32 and 300 deg F with an epoxy coating. Consult coating manufacturer for appropriate coating materials and application methods for operating temperature range.
- C. Coordinate insulation installation with the trade installing heat tracing. Comply with requirements for heat tracing that apply to insulation.
- D. Mix insulating cements with clean potable water; if insulating cements are to be in contact with stainless-steel surfaces, use demineralized water.

3.3 GENERAL INSTALLATION REQUIREMENTS

- A. Install insulation materials, accessories, and finishes with smooth, straight, and even surfaces; free of voids throughout the length of piping including fittings, valves, and specialties.
- B. Install insulation materials, forms, vapor barriers or retarders, jackets, and thicknesses required for each item of pipe system as specified in insulation system schedules.
- C. Install accessories compatible with insulation materials and suitable for the service. Install accessories that do not corrode, soften, or otherwise attack insulation or jacket in either wet or dry state.
- D. Install insulation with longitudinal seams at top and bottom of horizontal runs.
- E. Install multiple layers of insulation with longitudinal and end seams staggered.
- F. Do not weld brackets, clips, or other attachment devices to piping, fittings, and specialties.
- G. Keep insulation materials dry during application and finishing.
- H. Install insulation with tight longitudinal seams and end joints. Bond seams and joints with adhesive recommended by insulation material manufacturer.
- I. Install insulation with least number of joints practical.
- J. Where vapor barrier is indicated, seal joints, seams, and penetrations in insulation at hangers, supports, anchors, and other projections with vapor-barrier mastic.
 - 1. Install insulation continuously through hangers and around anchor attachments.
 - 2. For insulation application where vapor barriers are indicated, extend insulation on anchor legs from point of attachment to supported item to point of attachment to structure. Taper and seal ends at attachment to structure with vapor-barrier mastic.
 - 3. Install insert materials and install insulation to tightly join the insert. Seal insulation to insulation inserts with adhesive or sealing compound recommended by insulation material manufacturer.
 - 4. Cover inserts with jacket material matching adjacent pipe insulation. Install shields over jacket, arranged to protect jacket from tear or puncture by hanger, support, and shield.
- K. Apply adhesives, mastics, and sealants at manufacturer's recommended coverage rate and wet and dry film thicknesses.
- L. Install insulation with factory-applied jackets as follows:
 - 1. Draw jacket tight and smooth.
 - 2. Cover circumferential joints with 3-inch- wide strips, of same material as insulation jacket. Secure strips with adhesive and outward clinching staples along both edges of strip, spaced 4 inches o.c.
 - 3. Overlap jacket longitudinal seams at least 1-1/2 inches. Install insulation with longitudinal seams at bottom of pipe. Clean and dry surface to receive self-sealing lap. Staple laps with outward clinching staples along edge at
 - a. 2 inches o.c.
 - b. For below-ambient services, apply vapor-barrier mastic over staples.
 - 4. Cover joints and seams with tape, according to insulation material manufacturer's written instructions, to maintain vapor seal.
 - 5. Where vapor barriers are indicated, apply vapor-barrier mastic on seams and joints and at ends adjacent to pipe flanges and fittings.
- M. Cut insulation in a manner to avoid compressing insulation more than 75 percent of its nominal thickness.

- N. Finish installation with systems at operating conditions. Repair joint separations and cracking due to thermal movement.
- O. Repair damaged insulation facings by applying same facing material over damaged areas. Extend patches at least 4 inches beyond damaged areas. Adhere, staple, and seal patches similar to butt joints.
- P. For above-ambient services, do not install insulation to the following:
 - 1. Vibration-control devices.
 - 2. Testing agency labels and stamps.
 - 3. Nameplates and data plates.
 - 4. Manholes.
 - 5. Handholes.
 - 6. Cleanouts.

3.4 PENETRATIONS

- A. Insulation Installation at Roof Penetrations: Install insulation continuously through roof penetrations.
 - 1. Seal penetrations with flashing sealant.
 - 2. For applications requiring only indoor insulation, terminate insulation above roof surface and seal with joint sealant. For applications requiring indoor and outdoor insulation, install insulation for outdoor applications tightly joined to indoor insulation ends. Seal joint with joint sealant.
 - 3. Extend jacket of outdoor insulation outside roof flashing at least 2 inches below top of roof flashing.
 - 4. Seal jacket to roof flashing with flashing sealant.
- B. Insulation Installation at Underground Exterior Wall Penetrations: Terminate insulation flush with sleeve seal. Seal terminations with flashing sealant.
- C. Insulation Installation at Aboveground Exterior Wall Penetrations: Install insulation continuously through wall penetrations.
 - 1. Seal penetrations with flashing sealant.
 - 2. For applications requiring only indoor insulation, terminate insulation inside wall surface and seal with joint sealant. For applications requiring indoor and outdoor insulation, install insulation for outdoor applications tightly joined to indoor insulation ends. Seal joint with joint sealant.
 - 3. Extend jacket of outdoor insulation outside wall flashing and overlap wall flashing at least 2 inches.
 - 4. Seal jacket to wall flashing with flashing sealant.
- D. Insulation Installation at Interior Wall and Partition Penetrations (That Are Not Fire Rated): Install insulation continuously through walls and partitions.
- E. Insulation Installation at Fire-Rated Wall and Partition Penetrations: Install insulation continuously through penetrations of fire-rated walls and partitions.
 - 1. Comply with requirements in Section 078413 "Penetration Firestopping" for firestopping and fire-resistive joint sealers.
- F. Insulation Installation at Floor Penetrations:
 - 1. Pipe: Install insulation continuously through floor penetrations.

2. Seal penetrations through fire-rated assemblies. Comply with requirements in Division 07 section "Penetration Firestopping."

3.5 GENERAL PIPE INSULATION INSTALLATION

- A. Requirements in this article generally apply to all insulation materials except where more specific requirements are specified in various pipe insulation material installation articles.
- B. Insulation Installation on Fittings, Valves, Strainers, Flanges, and Unions:
 1. Install insulation over fittings, valves, strainers, flanges, unions, and other specialties with continuous thermal and vapor-retarder integrity unless otherwise indicated.
 2. Insulate pipe elbows using preformed fitting insulation or mitered fittings made from same material and density as adjacent pipe insulation. Each piece shall be butted tightly against adjoining piece and bonded with adhesive. Fill joints, seams, voids, and irregular surfaces with insulating cement finished to a smooth, hard, and uniform contour that is uniform with adjoining pipe insulation.
 3. Insulate tee fittings with preformed fitting insulation or sectional pipe insulation of same material and thickness as used for adjacent pipe. Cut sectional pipe insulation to fit. Butt each section closely to the next and hold in place with tie wire. Bond pieces with adhesive.
 4. Insulate valves using preformed fitting insulation or sectional pipe insulation of same material, density, and thickness as used for adjacent pipe. Overlap adjoining pipe insulation by not less than two times the thickness of pipe insulation, or one pipe diameter, whichever is thicker. For valves, insulate up to and including the bonnets, valve stuffing-box studs, bolts, and nuts. Fill joints, seams, and irregular surfaces with insulating cement.
 5. Insulate strainers using preformed fitting insulation or sectional pipe insulation of same material, density, and thickness as used for adjacent pipe. Overlap adjoining pipe insulation by not less than two times the thickness of pipe insulation, or one pipe diameter, whichever is thicker. Fill joints, seams, and irregular surfaces with insulating cement. Insulate strainers so strainer basket flange or plug can be easily removed and replaced without damaging the insulation and jacket. Provide a removable reusable insulation cover. For below-ambient services, provide a design that maintains vapor barrier.
 6. Insulate flanges and unions using a section of oversized preformed pipe insulation. Overlap adjoining pipe insulation by not less than two times the thickness of pipe insulation, or one pipe diameter, whichever is thicker.
 7. Cover segmented insulated surfaces with a layer of finishing cement and coat with a mastic. Install vapor-barrier mastic for below-ambient services and a breather mastic for above-ambient services. Reinforce the mastic with fabric-reinforcing mesh. Trowel the mastic to a smooth and well-shaped contour.
 8. For services not specified to receive a field-applied jacket except for flexible elastomeric install fitted PVC cover over elbows, tees, strainers, valves, flanges, and unions. Terminate ends with PVC end caps. Tape PVC covers to adjoining insulation facing using PVC tape.
 9. Stencil or label the outside insulation jacket of each union with the word "union." Match size and color of pipe labels.
- C. Insulate instrument connections for thermometers, pressure gages, pressure temperature taps, test connections, flow meters, sensors, switches, and transmitters on insulated pipes. Shape insulation at these connections by tapering it to and around the connection with insulating cement and finish with finishing cement, mastic, and flashing sealant.
- D. Install removable insulation covers at locations indicated. Installation shall conform to the following:

1. Make removable flange and union insulation from sectional pipe insulation of same thickness as that on adjoining pipe. Install same insulation jacket as adjoining pipe insulation.
2. When flange and union covers are made from sectional pipe insulation, extend insulation from flanges or union long at least two times the insulation thickness over adjacent pipe insulation on each side of flange or union. Secure flange cover in place with stainless-steel or aluminum bands. Select band material compatible with insulation and jacket.
3. Construct removable valve insulation covers in same manner as for flanges, except divide the two-part section on the vertical center line of valve body.
4. When covers are made from block insulation, make two halves, each consisting of mitered blocks wired to stainless-steel fabric. Secure this wire frame, with its attached insulation, to flanges with tie wire. Extend insulation at least 2 inches over adjacent pipe insulation on each side of valve. Fill space between flange or union cover and pipe insulation with insulating cement. Finish cover assembly with insulating cement applied in two coats. After first coat is dry, apply and trowel second coat to a smooth finish.
5. Unless a PVC jacket is indicated in field-applied jacket schedules, finish exposed surfaces with a metal jacket.

3.6 INSTALLATION OF CALCIUM SILICATE INSULATION

A. Insulation Installation on Straight Pipes and Tubes:

1. Secure single-layer insulation with stainless-steel bands at 12-inch intervals and tighten bands without deforming insulation materials.
2. Install two-layer insulation with joints tightly butted and staggered at least 3 inches. Secure inner layer with wire spaced at 12-inch intervals. Secure outer layer with stainless-steel bands at 12-inch intervals.
3. Apply a skim coat of mineral-fiber, hydraulic-setting cement to insulation surface. When cement is dry, apply flood coat of lagging adhesive and press on one layer of glass cloth or tape. Overlap edges at least 1 inch. Apply finish coat of lagging adhesive over glass cloth or tape. Thin finish coat to achieve smooth, uniform finish.

B. Insulation Installation on Pipe Flanges:

1. Install preformed pipe insulation to outer diameter of pipe flange.
2. Make width of insulation section same as overall width of flange and bolts, plus twice the thickness of pipe insulation.
3. Fill voids between inner circumference of flange insulation and outer circumference of adjacent straight pipe segments with cut sections of block insulation of same material and thickness as pipe insulation.
4. Finish flange insulation same as pipe insulation.

C. Insulation Installation on Pipe Fittings and Elbows:

1. Install preformed sections of same material as straight segments of pipe insulation when available. Secure according to manufacturer's written instructions.
2. When preformed insulation sections of insulation are not available, install mitered sections of calcium silicate insulation. Secure insulation materials with wire or bands.
3. Finish fittings insulation same as pipe insulation.

D. Insulation Installation on Valves and Pipe Specialties:

1. Install mitered segments of calcium silicate insulation to valve body. Arrange insulation to permit access to packing and to allow valve operation without disturbing insulation.
2. Install insulation to flanges as specified for flange insulation application.
3. Finish valve and specialty insulation same as pipe insulation.

3.7 INSTALLATION OF FLEXIBLE ELASTOMERIC INSULATION

- A. Seal longitudinal seams and end joints with manufacturers recommended adhesive to eliminate openings in insulation that allow passage of air to surface being insulated.
- B. Insulation Installation on Pipe Flanges:
 - 1. Install pipe insulation to outer diameter of pipe flange.
 - 2. Make width of insulation section same as overall width of flange and bolts, plus twice the thickness of pipe insulation.
 - 3. Fill voids between inner circumference of flange insulation and outer circumference of adjacent straight pipe segments with cut sections of sheet insulation of same thickness as pipe insulation.
 - 4. Secure insulation to flanges and seal seams with manufacturers recommended adhesive to eliminate openings in insulation that allow passage of air to surface being insulated.
- C. Insulation Installation on Pipe Fittings and Elbows:
 - 1. Install mitered sections of pipe insulation.
 - 2. Secure insulation materials and seal seams with manufacturer's recommended adhesive to eliminate openings in insulation that allow passage of air to surface being insulated.
- D. Insulation Installation on Valves and Pipe Specialties:
 - 1. Install preformed valve covers manufactured of same material as pipe insulation when available.
 - 2. When preformed valve covers are not available, install cut sections of pipe and sheet insulation to valve body. Arrange insulation to permit access to packing and to allow valve operation without disturbing insulation.
 - 3. Install insulation to flanges as specified for flange insulation application.
 - 4. Secure insulation to valves and specialties and seal seams with manufacturer's recommended adhesive to eliminate openings in insulation that allow passage of air to surface being insulated.

3.8 INSTALLATION OF MINERAL-FIBER INSULATION

- A. Insulation Installation on Straight Pipes and Tubes:
 - 1. Secure each layer of preformed pipe insulation to pipe with wire or bands and tighten bands without deforming insulation materials.
 - 2. Where vapor barriers are indicated, seal longitudinal seams, end joints, and protrusions with vapor-barrier mastic and joint sealant.
 - 3. For insulation with factory-applied jackets on above-ambient surfaces, secure laps with outward-clinched staples at 6 inches o.c.
 - 4. For insulation with factory-applied jackets on below-ambient surfaces, do not staple longitudinal tabs. Instead, secure tabs with additional adhesive as recommended by insulation material manufacturer and seal with vapor-barrier mastic and flashing sealant.
- B. Insulation Installation on Pipe Flanges:
 - 1. Install preformed pipe insulation to outer diameter of pipe flange.
 - 2. Make width of insulation section same as overall width of flange and bolts, plus twice the thickness of pipe insulation.
 - 3. Fill voids between inner circumference of flange insulation and outer circumference of adjacent straight pipe segments with mineral-fiber blanket insulation.
 - 4. Install jacket material with manufacturer's recommended adhesive, overlap seams at least 1 inch, and seal joints with flashing sealant.
- C. Insulation Installation on Pipe Fittings and Elbows:

1. Install preformed sections of same material as straight segments of pipe insulation when available.
2. When preformed insulation elbows and fittings are not available, install mitered sections of pipe insulation, to a thickness equal to adjoining pipe insulation. Secure insulation materials with wire or bands.

D. Insulation Installation on Valves and Pipe Specialties:

1. Install preformed sections of same material as straight segments of pipe insulation when available.
2. When preformed sections are not available, install mitered sections of pipe insulation to valve body.
3. Arrange insulation to permit access to packing and to allow valve operation without disturbing insulation.
4. Install insulation to flanges as specified for flange insulation application.

3.9 FIELD-APPLIED JACKET INSTALLATION

A. Where PVC jackets are indicated, install with 1-inch overlap at longitudinal seams and end joints; for horizontal applications. Seal with manufacturers recommended adhesive.

1. Apply two continuous beads of adhesive to seams and joints, one bead under lap and the finish bead along seam and joint edge.

3.10 PIPING INSULATION SCHEDULE, GENERAL

A. Acceptable preformed pipe and tubular insulation materials and thicknesses are identified for each piping system and pipe size range. If more than one material is listed for a piping system, selection from materials listed is Contractor's option.

B. Items Not Insulated: Unless otherwise indicated, do not install insulation on the following:

1. Drainage piping located in crawl spaces.
2. Underground piping.
3. Chrome-plated pipes and fittings unless there is a potential for personnel injury.

3.11 INDOOR PIPING INSULATION SCHEDULE

A. Condensate and Equipment Drain Water below 60 Deg F:

1. All Pipe Sizes: Insulation shall be one of the following:
 - a. Flexible Elastomeric:
 - 1) 1/2 inch thick
 - b. Mineral-Fiber, Preformed Pipe Insulation, Type I:
 - 1) 1/2 inch thick

B. Chilled Water, 40 Deg F and below:

1. NPS 1-1/2 inch and Smaller: Insulation shall be the following:
 - a. Flexible Elastomeric:
 - 1) 1-1/2 inch thick.
2. NPS 2 inch and Larger: Insulation shall be the following:
 - a. Flexible Elastomeric:
 - 1) 2 inch thick

3. Insulation for runouts not exceeding 48 inches in length for connection to equipment shall be the following:
 - a. Flexible Elastomeric: 1 inch thick.
- C. Chilled Water, above 40 Deg F:
1. NPS 1-1/2 inch and Smaller: Insulation shall be the following:
 - a. Flexible Elastomeric:
 - 1) 1-1/2 inch thick.
 - b. Mineral-Fiber, Preformed Pipe, Type I:
 - 1) 1-1/2 inches thick.
 2. NPS 2 inch and Larger: Insulation shall be the following:
 - a. Flexible Elastomeric:
 - 1) 2 inch thick.
 - b. Mineral-Fiber, Preformed Pipe, Type I:
 - 1) 2 inch thick.
 3. Insulation runouts not exceeding 48 inches in length for connection to equipment shall be one of the following:
 - a. Flexible Elastomeric: 1 inch thick.
 - b. Mineral-Fiber, Preformed Pipe, Type I: 1 inch thick
- D. Condenser-Water Supply and Return:
1. All Pipe Sizes: Insulation shall be one of the following:
 - a. Flexible Elastomeric: 1 inch thick.
 - b. Mineral-Fiber, Preformed Pipe, Type I:
 - 1) 1 inch thick
 2. Condenser-water supply and return piping located indoors and operating in range of 55 to 105 deg F (13 to 41 deg C) is not always insulated. If condenser-water system operates as part of a water-side economizer cycle or if Project requires condensation control, piping should be insulated.
- E. Heating-Hot-Water Supply and Return, 200 Deg F and Below:
1. NPS 1 1/2 and Smaller: Insulation shall be the following:
 - a. Mineral-Fiber, Preformed Pipe, Type I:
 - 1) 1-1/2 inch thick
 2. Greater than NPS 1-1/2 inch : Insulation shall be the following:
 - a. Mineral-Fiber, Preformed Pipe, Type I or Pipe and Tank Insulation:
 - 1) 2 inches thick
 3. Insulation for runouts not exceeding 48 inches in length for connection to equipment shall be the following:
 - a. Mineral-Fiber, Preformed Pipe, Type I: 1 inch thick.
- F. Heating-Hot-Water Supply and Return, above 200 Deg F:
1. NPS 1 and Smaller: Insulation shall be one of the following:
 - a. Calcium Silicate:
 - 1) 2 inches thick
 - b. Mineral-Fiber, Preformed Pipe, Type I or II:
 - 1) 1-1/2 inches thick

2. NPS 1-1/4 and Larger: Insulation shall be one of the following:
 - a. Calcium Silicate:
 - 1) 3 inches thick
 - b. Mineral-Fiber, Preformed Pipe, Type I or II:
 - 1) 2 inches thick
 3. Insulation runouts not exceeding 48 inches in length for connection to equipment shall be the following:
 - a. Mineral-Fiber, Preformed Pipe, Type I: 1-1/2 inch thick.
- G. Steam and Steam Condensate, 0 to 15 PSI, 200 Deg F to 250 Deg F :
1. NPS 1 and Smaller: Insulation shall be one of the following:
 - a. Calcium Silicate:
 - 1) 2 inches thick
 - b. Mineral-Fiber, Preformed Pipe, Type I or II:
 - 1) 1-1/2 inches thick
 2. NPS 1-1/4 and Larger: Insulation shall be one of the following:
 - a. Calcium Silicate:
 - 1) 3 inches
 - b. Mineral-Fiber, Preformed Pipe, Type I or II or Pipe and Tank Insulation:
 - 1) 2 inches thick
 3. Insulation for runouts not exceeding 48" in length for connection to equipment shall be the following:
 - a. Mineral-Fiber, Preformed Pipe, Type I: 1-1/2 inch thick.
- H. Steam and Steam Condensate, 16 to 60 PSI, 251 Deg F to 305 Deg F :
1. NPS 1 and Smaller: Insulation shall be one of the following:
 - a. Calcium Silicate: 3 inches thick.
 - b. Mineral-Fiber, Preformed Pipe, Type I or II: 2 inches thick.
 2. NPS 1-1/4 and Larger: Insulation shall be one of the following:
 - a. Calcium Silicate: 3 inches thick.
 - b. Mineral-Fiber, Preformed Pipe, Type I or II or Pipe and Tank Insulation: 2 inches thick.
 3. Insulation for runouts not exceeding 48 inches in length for connection to equipment shall be the following:
 - a. Mineral-Fiber, Preformed Pipe, Type I: 1-1/2 inch thick.
- I. Refrigerant Suction and Hot-Gas Piping:
1. All Pipe Sizes: Insulation shall be one of the following:
 - a. Flexible Elastomeric: 1 inch thick.
- J. Refrigerant Suction and Hot-Gas Flexible Tubing:
1. All Pipe Sizes: Insulation shall be the following:

- a. Flexible Elastomeric: 1 inch thick.

3.12 INDOOR, FIELD-APPLIED JACKET SCHEDULE

- A. Install jacket over insulation material. For insulation with factory-applied jacket, install the field-applied jacket over the factory-applied jacket.
- B. If more than one material is listed, selection from materials listed is Contractor's option.
- C. Piping, Concealed:
 - 1. None.
- D. Piping, Exposed:
 - 1. PVC:
 - a. PVC, white: 30 mils thick.
- E. Steam Piping, Exposed:
 - 1. Aluminum, Stucco Embossed: 0.016 inch thick.

3.13 OUTDOOR, FIELD-APPLIED JACKET SCHEDULE

- A. Install jacket over insulation material. For insulation with factory-applied jacket, install the field-applied jacket over the factory-applied jacket.
- B. If more than one material is listed, selection from materials listed is Contractor's option.
- C. Piping, Concealed:
 - 1. None.
- D. Piping, Exposed:
 - 1. Aluminum, Stucco Embossed: 0.016 inch thick.

3.14 UNDERGROUND, FIELD-INSTALLED INSULATION JACKET

- A. For underground direct-buried piping applications, install underground direct-buried jacket over insulation material.

END OF SECTION 23 0719

SECTION 23 0900

INSTRUMENTATION AND CONTROL FOR HVAC

PART 1 - GENERAL

1.1 SCOPE OF WORK

- A. The Facility Management and Control System (FMCS) Contractor shall furnish and install a fully integrated building automation system, incorporating direct digital control (DDC) for energy management, equipment monitoring and control as herein specified. The system shall include all required computer software and hardware, controllers, sensors, transmission equipment, system workstations, local panels, conduit, wire, installation, engineering, database and setup, supervision, commissioning, acceptance test, training, warranty service and, at the owner's option, extended warranty service. The system shall be an extension of the existing hospital's Insight system by JCI.
- B. The system shall use BACnet as its floor level protocol. System components shall be certified and display the BTL logo where applicable.
- C. The FMCS shall demonstrate, with (3) proof sources, integration with HVAC industry open standard protocols, including LonMark, BACnet, Modbus, and Internet standard SQL database and HTTP / HTML / XML text formats.
- D. The FMCS shall communicate to third party systems such as chillers, energy metering systems, other energy management systems, and other building management related devices using any of the open, interoperable communication protocols referenced in Paragraph C.
- E. All materials and equipment used shall be standard components, regularly manufactured for this and/or other systems and not custom designed especially for this project
- F. Plenum rated cable is allowed for low voltage control wiring.
- G. Existing system is JCI Johnson Controls.
- H. Provide BMS integration with all new VAV boxes and exhaust fans. Graphics to match existing with updated floor plans and navigation to be seamlessly integrated with existing.

1.2 RELATED WORK SPECIFIED ELSEWHERE

- A. Drawings and general provisions of the Contract, including General and supplementary Conditions and Division-1 specification sections, apply to work of this section.
- B. Products furnished but not installed under this section:
 - 1. Valves, flow switches, flow sensors, thermowells and pressure taps to be installed under Section 23000.
 - 2. Automatic dampers to be installed under Section 23000.
- C. Coordination with electrical:

1. If new control panel is required, all line voltage and data requirements shall be furnished as part of work of the FMCS.
2. Each motor starter provided under Division 26000, shall be furnished with individual control power transformer to supply 120-volt AC control power and auxiliary contacts (one N.O. and one N.C.) for use by this section.

1.3 QUALITY ASSURANCE

- A. The system shall be furnished, engineered, and installed by the manufacturers' locally authorized representative. The controls contractor shall have factory-trained technicians to provide instruction, routine maintenance, and emergency service within 24 hours upon receipt of request.
- B. At the time of bid, all FMCS Application Specific Controllers and Programmable Equipment Controllers shall be listed as follows:
 1. Underwriters Laboratory UL 916
 2. FCC Regulation, Part 15, Class B

1.4 SUBMITTALS

- A. Submit 10 complete sets of documentation in the following phased delivery schedule:
 1. Valve and damper schedules
 2. Equipment data cut sheets
 3. System schematics, including:
 - a. sequence of operations
 - b. point names
 - c. point addresses
 - d. point to point wiring
 - e. interface wiring diagrams
 - f. panel layouts
 - g. system riser diagrams
 - h. sample graphics
 4. AutoCAD® compatible as-built drawings
- B. Upon project completion, submit operation and maintenance manuals, consisting of the following:
 1. Index sheet, listing contents in alphabetical order
 2. Manufacturer's equipment parts list of all functional components of the system, disk of system schematics, including wiring diagrams
 3. Description of sequence of operations
 4. As-Built interconnection wiring diagrams

5. User's documentation containing product, system architectural and programming information.
6. Trunk cable schematic showing remote electronic panel locations, and all trunk data
7. List of connected data points, including panels to which they are connected and input device (ionization detector, sensors, etc.)
8. Conduit routing diagrams
9. Copy of the warranty/guarantee
10. Operating and maintenance cautions and instructions
11. Recommended spare parts list

PART 2 - PRODUCTS

2.1 ACCEPTABLE MANUFACTURERS

Johnson Controls

2.2 The Facility Management Control System (FMCS) shall be comprised of a network of interoperable, stand-alone digital controllers. The FMCS shall incorporate BACnet technology. The system shall include:

- A. Programmable Equipment Controllers (PEC's) for control of primary mechanical systems and distributed system applications. Controllers shall be fully programmable to create custom control solutions.
- B. Network Area Controllers (NAC's) for distributed system applications, databases and networking functions.
- C. Application Specific Controllers (ASC's) for control of VAV terminal units, fan coil terminal units, unit vent terminal units, heat pump units and other terminal equipment.
- D. Graphical User Interface (GUI), which includes the hardware and software necessary for a user to interface with the control system and devices. (SUPERVISOR)
- E. The zone controller network shall use twisted pair wiring and 78Kbps RS485 BACnet MSTP wiring topologies. The GU, PEC and NAC shall reside on a 100 Mb Ethernet backbone.
- F. All components and controllers supplied under this contract shall be true "peer-to-peer" communicating devices. Components or controllers requiring "polling" by a host to pass data shall not be acceptable.
- G. Communication and integration of 3rd party BACnet products shall be accomplished without gateways or interface devices. The 3rd party product supplier shall provide BACnet pic statements for each device.

2.3 NETWORK AREA CONTROLLER (NAC)

- A. The Network Area Controller (NAC) shall provide the interface between the field control devices, and provide global supervisory control functions over the control devices connected to the NAC. The NAC shall be JACE 8000. It shall be capable of executing application control programs to provide:
1. Calendar functions
 2. Scheduling
 3. Trending
 4. Alarm monitoring and routing
 5. Time synchronization
 6. Integration of BACnet controller data
 7. Integration of BACnet and MODBUS networks
 8. Lon Network
 9. Monitoring, control, and programming of all points.
 10. Network Management functions for all BACnet based devices
 11. Employ Insight operating system
- B. The NAC shall provide multiple, concurrent user access to the system and support for ODBC or SQL. A database resident on the NAC shall be an ODBC-compliant database or must provide an ODBC data access mechanism to read and write data stored within it.
- C. The NAC shall support standard Web browser access via the Intranet/Internet. It shall support a minimum of 16 simultaneous users.
- D. The NAC shall provide alarm recognition, storage; routing, management, and analysis to supplement distributed capabilities of equipment or application specific controllers.
1. The NAC shall be able to route any alarm condition to any defined user location whether connected to a local network or remote via dial-up, telephone connection, or wide-area network.
 2. Alarm generation shall be selectable for annunciation type and acknowledgement requirements including, but not limited to:
 - a. To alarm
 - b. Return to normal
 - c. To fault
 3. Provide for the creation of an unlimited number of alarm classes for the purpose of routing types and or classes of alarms, i.e.: security, HVAC, Fire, etc.
 4. Provide timed (schedule) routing of alarms by class, object, group, or node.
 5. Provide alarm generation from binary object "runtime" and /or event counts for equipment maintenance. The user shall be able to reset runtime or event count values with appropriate password control.
- E. Alarms shall be annunciated in any of the following manners as user defined:
1. Screen message text
 2. Email of the complete alarm message to multiple recipients. Provide the ability to route and email alarms based on:
 - a. Day of week
 - b. Time of day
 - c. Recipient
 3. Graphic with flashing alarm object(s)
 4. Printed message, routed directly to a dedicated alarm printer

- F. The following shall be recorded by the NAC for each alarm (at a minimum):
1. Time and date
 2. Location (building, floor, zone, office number, etc.)
 3. Equipment (air handler #, access way, etc.)
 4. Acknowledge time, date, and user who issued acknowledgement.
 5. Number of occurrences since last acknowledgement.
- G. Defined users shall be given proper access to acknowledge any alarm, or specific types or classes of alarms defined by the user.
- H. A log of all alarms shall be maintained by the SUPERVISOR and shall be available for review by the user.
- I. Provide a “query” feature to allow review of specific alarms by user defined parameters.
- J. A separate log for system alerts (controller failures, network failures, etc.) shall be provided and available for review by the user.
- K. An Error Log to record invalid property changes or commands shall be provided and available for review by the user.
- L. Data Collection and Storage
1. The NAC shall have the ability to collect data for any property of any object and store this data for future use.
 2. The data collection shall be performed by log objects, resident in the NAC that shall have, at a minimum, the following configurable properties:
 - a. Designating the log as interval or deviation.
 - b. For interval logs, the object shall be configured for time of day, day of week and the sample collection interval.
 - c. For deviation logs, the object shall be configured for the deviation of a variable to a fixed value. This value, when reached, will initiate logging of the object.
 - d. For all logs, provide the ability to set the maximum number of data stores for the log and to set whether the log will stop collecting when full, or rollover the data on a first-in, first-out basis.
 - e. Each log shall have the ability to have its data cleared on a time-based event or by a user-defined event or action.
 3. All log data shall be stored in a relational database in the NAC and the data shall be accessed from a server (if the system is so configured) or a standard Web Browser.
 4. All log data, when accessed from a server, shall be capable of being manipulated using standard SQL statements.
 5. All log data shall be available to the user in the following data formats:
 - a. HTML
 - b. XML
 - c. Plain Text
 - d. Comma or tab separated values
 6. Systems that do not provide log data in HTML and XML formats at a minimum shall not be acceptable.

7. The NAC shall have the ability to archive its log data either locally (to itself), or remotely to a server or other NAC on the network. Provide the ability to configure the following archiving properties, at a minimum:
 - a. Archive on time of day
 - b. Archive on user-defined number of data stores in the buffer (size)
 - c. Archive when buffer has reached its user-defined capacity

- M. Provide and maintain an Audit Log that tracks all activities performed on the NAC. Provide the ability to specify a buffer size for the log and the ability to archive log based on time or when the log has reached its user-defined buffer size. Provide the ability to archive the log to the SUPERVISOR. For each log entry, provide the following data:
 1. Time and date
 2. User ID
 3. Change or activity: i.e., Change set point, add or delete objects, commands, etc.

- N. The NAC shall have the ability to automatically backup its database to the SUPERVISOR. The database shall be backed up based on a user-defined time interval.
 1. Copies of the current database and, at the most recently saved database shall be stored in the NAC. The age of the most recently saved database is dependent on the user-defined database save interval.
 2. The NAC database shall be stored, at a minimum, in XML format to allow for user viewing and editing, if desired. Other formats are acceptable as well, as long as XML format is supported.

- O. Each Network Area Controller (NAC) that is part of the Ethernet backbone shall include local battery backed UPSs sized for 30 minutes backup.

2.4 PROGRAMMABLE EQUIPMENT CONTROLLERS (PEC)

- A. Programmable Equipment Controllers (PEC's) shall be stand-alone, multi-tasking, real-time digital control processors.
- B. The PEC's shall communicate via native BACnet MSTP protocol. Provide a minimum of 4MB Random Access Memory in each PEC.
- C. The PEC must communicate peer-to-peer with the all of the network application specific, programmable controllers and third party BACnet devices.
- D. Programming of the PEC shall be accomplished by using graphical software that incorporates drag and drop capabilities. The PEC software database must be able to execute all of the specified mechanical system controls functions. The programming software shall be able to bundle software logic to simplify control sequencing. All values, which make up the PID output value, shall be readable and modifiable at a workstation or portable service tool. Each input, output, or calculation result shall be capable of being shared/bound with any controller or interface device on the network.
- E. PEC's shall be able to execute custom, job specific processes defined by the user, to automatically perform calculations and special control routines.
- F. A single process shall be able to incorporate measured or calculated data from any and all other PEC's on the network. In addition, a single process shall be able to issue commands to points in any and all other PEC's on the network.

- G. Each PEC shall support firmware upgrades without the need to replace hardware.
- H. Each PEC shall continuously perform self-diagnostics, which include communication diagnosis and diagnosis of all components. The PEC shall provide both local and remote annunciation of any detected component failures, low battery conditions or repeated failure to establish communication.
- I. In the event of the loss of normal power, there shall be an orderly shutdown of all PEC's to prevent the loss of database or operating system software. Non-volatile memory shall be incorporated for all critical controller configuration data and battery backup shall be provided to support the real-time clock and all volatile memory for a minimum of 72 hours.
 - 1. Upon restoration of normal power, the PEC shall automatically resume full operation without manual intervention.
 - 2. All PEC's control programming and databases must be stored in Flash memory, therefore eliminating data loss, down time and re-load time.

2.5 APPLICATION SPECIFIC CONTROLLERS (ASC)

- A. Each Application Specific Controller (ASC) shall operate as a stand-alone BACnet MSTP compliant controller capable of performing its specified control responsibilities independent of other controllers in the network. Each ASC shall be a minimum 16-BIT microprocessor based, multi-tasking, multi-user, real time digital control processor.
- B. Service pin initiation shall be accomplished from the room sensor and/or the controller. ASC room sensors that do not provide service pin initiation must provide a wall jack by the room sensor to enable this feature.
- C. Controllers shall include all inputs and outputs necessary to perform the specified control sequences. Analog and digital outputs shall be industry standard signals such as 0-10V and 3-point floating control allowing for interface to a variety of industry standard modulating actuators. The ASC inputs and outputs shall consist of industry standards types. Inputs shall be electrically isolated from outputs, communications and power. All inputs shall be provided with an auto-calibrate function to eliminate sensing errors.
- D. All controller sequences and operation shall provide closed loop control of the intended application. Closing control loops over the network is not acceptable.
- E. The ASC must be mounted remotely from the room sensor. ASC's, that are wall mounted with integral room sensors, are not acceptable.
- F. The control program shall reside in the ASC. The application program and the configuration information shall be stored in non-volatile memory with no battery back-up required.
- G. After a power failure the ASC must run the control application using the current set points and configuration. Reverting to default or factory set points are not acceptable.

2.6 PROJECT SPECIFIC WEB PAGES

- A. Home page shall include a campus layout of the individual buildings at the site. Once an individual building is selected the following minimum web-based tree structure shall be provided:

1. Documents Page: The document page shall include the O&M Manuals for the control system in PDF format along with AutoCAD drawings for each drawing provided in the control system O&M Manual.
2. Station Functions:
 - a. Logging separate sheet of station functions for a particular selected building shall be the viewing of one or more logs or the creation of logs in which any value at any point, or the mode of any point, shall be selected via the web to be trended against any other point with an adjustable frequency in seconds, minutes, hours or days.
 - b. The alarm acknowledgement via the web shall allow the viewing and acknowledgement of the alarms.
 - c. Audit log shall be provided via the web to show the operator actions as well as other audit logs as specified in section 2.5 Network Area Controller (NAC) paragraph "M" Data Collection and Storage.
3. Floor Plans:
 - a. AutoCAD drawings of floor plans shall be provided in the control system such that via the web the user shall be able to turn layers on and off on the mechanical floor plans. These floor plans shall also include an overlay of the temperature control as-built wiring for the project showing thermostat locations, communication runs, transformer locations, controller locations, etc.
 - b. Floor Display Summaries. The operator shall be able to select floor plans (new floor plan if existing) displaying the following formats:
 1. All zone temperatures
 2. All zone heating percentages
 3. All zone cooling percentages
 4. All zone room names and numbers
 5. All zones cfm delivered.
 - c. Upon selecting a graphical floor plan layout, the web page shall show all the zone temperature sensor locations on the floor. By clicking on the zone temperature location, an individual VAV box graphic shall be displayed with the following attributes:
 1. A manual menu that shall allow the operator to manually set the air flow set point, space temperature set point, damper position, cooling percentage, heating percentage, and zero the box.
 2. A 24-hour log chart that shows space temperature history, flow history, and allows the operator to build custom charts by comparing this log to other associated selectable logs.
 3. A display of the VAV box discharge temperature, air handler discharge temperature, space temperature, and space temperature set point.
 4. A bar graph that shows actual CFM, current air flow, and current air flow set point, percentage of heating and cooling in a thermometer-like fashion and changes color based on heating or cooling mode.
 5. The damper position, reheat valve position, occupancy status, room name and heating/cooling mode shall also be shown.
4. Systems:
 - a. On selecting the systems menu, a tree structure shall allow the operator to select the air handlers, boilers, chillers, control valves, pumps, heat exchangers, lab air flow valves and hoods, etc. systems associated with that building. The graphics

shall also show the piping and ductwork associated with the air handler as well as the safeties, temperature sensors, humidity sensors, dampers, VFD's, associated with that fan system. See points lists for specifics.

- b. All devices that provide dynamic function in the primary equipment, i.e., fans, pumps, coils, dampers shall be dynamic in nature showing their operating status/percentage of capacity by movement on the web page.
- c. The set points for the various control loops shall be adjustable via the web page. Individual controlled devices, i.e. valves, dampers and fans shall be controlled via the web page and be stopped or started or placed in a command state or percentage of value output.

2.7 FIELD DEVICES

- A. Provide automatic control valves, automatic control dampers, thermostats, clocks, sensors, controllers, and other components as required for complete installation. Except as otherwise indicated, provide manufacturer's standard control system components as indicated by published product information, designed and constructed as recommended by manufacturer.

B. TEMPERATURE SENSORS

- 1. Temperature Sensors: Temperature sensors shall be linear precision elements with ranges appropriate for each specific application. Where sensors are located in public areas they shall not employ set point adjustments or override capability. Set point adjustment shall be programmed for $\pm 2.5^\circ$ maximum initially.
- 2. Space (room) sensors shall be available with set point adjustment and override switch.
- 3. Duct mounted averaging sensors shall utilize a sensing element incorporated in a copper capillary with a minimum length of 20 feet. The sensor shall be installed according to manufacture recommendation and looped and fastened at a minimum of every 36 inches.
- 4. Sunshields shall be provided for outside air sensors.
- 5. Thermo-wells for all immersion sensors shall be stainless steel or brass as required for the application.

C. SWITCHES AND THERMOSTATS

- 1. The FMCS Contractor shall furnish all electric relays and coordinate with the supplier of magnetic starters for auxiliary contact requirements. All electric control devices shall be of a type to meet current, voltage, and switching requirement of their particular application. Relays shall be provided with 24 VAC coils and contacts shall be rated at 10 amps minimum.
- 2. Differential Pressure Switches: Pressure differential switches shall have SPDT changeover contact, switching at an adjustable differential pressure set point.
- 3. Low Temperature Detection Thermostats: Shall be the manual reset type. The thermostat shall operate in response to the coldest one-foot length of the 20-foot sensing element, regardless of the temperatures at other parts of the element. The element shall be properly supported to cover the entire downstream side of the coil with a minimum of three loops. Separate thermostats shall be provided for each 25 square feet of coil face area or fraction thereof.

4. Current Sensing Relays: Motor status indications, where shown on the plans point list shall be provided via current sensing relays. The switch output contact shall be rated for 30 VDC, .15 amps.
5. Flow Switches: Motor status indications, where shown on the plans point list, shall be provided via flow switches. Flow switches shall be of the paddle type equipped with SPDT contacts to establish proof of flow.

D. CONTROL VALVES

1. General: Control Valves up to 4 inches shall be sized for a 3 to 5 psi pressure drop. Valves shall be packless, modulating, electrically or magnetically actuated, with a control rangeability of 100 to 1. These valves shall have equal percentage flow characteristics in relationship to valve opening.

E. DAMPER ACTUATORS

1. Actuators shall be of the push-pull or rotary type of modulating, 3-point floating, or 2-position control as required by the application. The actuator shall use an overload-proof synchronous motor or an electric motor with end switches to de-energize the motor at the end of the stroke limits. Control voltage shall be 24 VAC, 0-10 VDC, or 4-20 ma as required. Actuators shall be available with spring return to the normal position when required. Actuators shall have a position indicator for external indication of damper position. Actuators shall have manual override capability without disconnecting damper linkage. Actuators for purge system shall meet failsafe and smoke control speed requirements.

F. CONTROL DAMPERS

1. Motorized dampers, unless otherwise specified elsewhere, shall have damper frames using 13 gauge galvanized steel channel or 1/8" extruded aluminum with reinforced corner bracing. Damper blades shall not exceed ten (10) inches in width or 48" in length. Blades are to be suitable for high velocity performance. Damper bearings shall be as recommended by manufacturer for application. Bushings that turn in the bearing are to be oil impregnated sintered metal. All blade edges and top and bottom of the frame shall be provided with replaceable, butyl rubber or neoprene seals. Side seals may be spring-loaded stainless steel. The seals shall provide a maximum of 1% leakage at a wide open face velocity of 1500 FPM and 4: W.C. close-off pressure. The damper linkage shall provide a linear flow or equal percentage characteristic as required. Provide Ruskin RCD60 model.
2. Control dampers shall be parallel or opposed blade type as scheduled on drawings or outdoor and return air mixing box dampers shall be parallel blade, arranged to direct air streams towards each other. All other dampers may be parallel or opposed blade types.

2.8 PROJECT MANAGEMENT

- A. Provide a manager who shall, as part of his duties, be responsible for the following activities:
 - 1. Coordination between the Controls Contractor and all other trades, owner, local authorities and the design team.
 - 2. Scheduling of manpower, material delivery, equipment installation and checkout.
 - 3. Maintenance of construction records such as project scheduling and manpower planning and AutoCAD or Visio for project co-ordination and as-built drawings.
 - 4. Coordination/single point of contact.

2.9 INSTALLATION METHODS

- A. Install systems and materials in accordance with manufacturer's instructions, rough-in drawings and equipment details. Install electrical components and use electrical products complying with requirements of applicable Division 26000 sections of these specifications.

The contractor is required to deliver a functionally complete operating building. Provide unconditional one-year parts and service warranty. Warranty period commences when architectural substantial completion has been achieved.
- B. The term "control wiring" is defined to include providing of wire, conduit, and miscellaneous materials as required for mounting and connecting electric or electronic control devices.
- C. All exposed wiring, low and line voltage subject to mechanical damage, shall be run in conduit. Line and low voltage wiring shall be run in separate conduits. Concealed but accessible wiring, except in mechanical rooms and areas where other conduit and piping are exposed shall run in UL plenum rated cable as approved by local codes unless expressly restricted by requirements in Division 26000 specification. Control wiring below 8 feet in Mechanical Rooms and areas exposed to severe physical damage (i.e. loading dock, corridors subject to carts, forklifts, etc.) may be run in EMT conduit in lieu of rigid conduit as required in Section 260533.
- D. All controllers, relays, transducers, etc., required for stand-alone control shall be housed in a NEMA 1 enclosure with a lockable door.

2.10 SYSTEM ACCEPTANCE

- A. General: The system installation shall be complete and tested for proper operation prior to acceptance testing for the Owner's authorized representative. A letter shall be submitted to the Architect requesting system acceptance. This letter shall certify all controls are installed and the software programs have been completely exercised for proper equipment operation. Acceptance testing will commence at a mutually agreeable time within ten (10) calendar days of request. When the field test procedures have been demonstrated to the Owner's representative, the system will be accepted. The warranty period will start at this time.
- B. Field Equipment Test Procedures: DDC control panels shall be demonstrated via a functional end-to-end test. Such that:
 - 1. All output points shall be commanded (on/off, stop/start, adjust, etc.) and their operation verified.

2. All analog input points shall be verified for proper operation.
 3. All digital input points shall be verified by changing the state of the field device and observing the appropriate change of displayed value.
 4. If a point should fail testing, perform necessary repair action and retest failed point and all interlocked points.
 5. Automatic control operation shall be verified by introducing an error into the system and observing the proper corrective system response.
 6. Selected time and set point schedules shall be verified by changing the schedule and observing the correct response on the controlled outputs.
- C. As-Built Documentation: After a successful acceptance demonstration, the Contractor shall submit as-built drawings of the completed project for final approval. After receiving final approval, supply "6" complete 11x17 as-built drawing sets, together with AutoCAD or Visio diskettes to the owner.
- D. Operation and Maintenance Manuals: Submit four copies of operation and maintenance manuals. Include the following
1. Manufacturer's catalog data and specifications on sensors, transmitters, controllers, control valves, damper actuators, gauges, indicators, terminals, and any miscellaneous components used in the system.
 2. An operator's manual that will include detailed instructions for all operations of the system.
 3. An operator's reference table listing the addresses of all connected input points and output points. Settings shall be shown where applicable.
 4. A copy of the warranty/guarantee.
 5. Operating and maintenance cautions and instructions.

2.11 TRAINING

- A. Contractor shall provide to the engineer a training class outline prior to any scheduled training.
- B. Factory trained control engineers and technicians shall provide 1 training sessions (2 Hrs each) for the Owner's personnel.
- C. The course shall include instruction on specific systems and instructions for operating the installed system to include as a minimum:
1. HVAC system overview
 2. Operation of control system
 3. Function of each component
 4. System operating procedures
 5. Programming procedures
 6. Maintenance procedures

2.12 WARRANTY/GUARANTEE

- A. The control system shall be warranted/guaranteed to be free from defects in both material and workmanship for a period of twelve (12) months of normal use and service. This warranty/guarantee shall become effective the date the owner accepts or receives beneficial use of the system as defined by Utah state law.

PART 3 - SEQUENCE OF OPERATION

3.1 GENERAL:

- A. All mechanical equipment shall be monitored thru the DDC Control system with proof of flow devices. The run time of a monitored motors shall be available at the Facility Management System. Console. A maintenance alarm message shall be programmed at a specific run time as designated by the system operator. The alarm message shall be a designated by the operator.

B. EXHAUST FAN

This fan shall run continuously as commanded by the BMS. A fan status shall monitor the fan for proof of flow and alarm the BMS system upon fan failure.

C. VAV ZONES WITH REHEAT COIL

1. Occupied mode of the zone controller shall be determined by the central control. In the occupied mode if the space temperature is between the heating temperature and the cooling temperature set point, the box shall be in a dead band mode. The local DDC control loop shall modulate the primary damper to maintain the ventilation minimum CFM set point. On a fall in space temperature equal to the heating temperature set point, the controller shall then modulate the reheat coil as well as reset the supply air volume between the ventilation minimum and the heating maximum set point. The heating volume shall be a function of the heating calculation percentage to minimize the amount of reheat. On a 100% call for heat, the VAV box shall control to the maximum heating velocity set point and the control valve shall be wide open. A discharge sensor/control loop limits the supply air temperature 15° F above setpoint maximum programmable.
 2. The reverse shall occur on an increase in space temperature equal to or greater than the heating temperature set point. When the space temperature is equal to or greater than the cooling temperature set point the VAV box shall enter the cooling mode. The controller shall reset the box CFM set point from the minimum ventilation set point to the cooling maximum set point.
 3. In the unoccupied mode the VAV box damper shall be closed and the reheat coil valve closed. On a fall in space temperature below the unoccupied heating set point the control valve shall open and the primary air damper shall control to the heating volume to maintain the night set back setting.
1. All VAV and constant volume boxes in the system shall be equipped with discharge air temperature sensors and the FMCS shall monitor and display the discharge air temperature, zone temperature, zone setpoint, airflow, reheat valve position and mode at a minimum (match existing VAV graphics when applicable).

- D. Zone occupancy is to be controlled by the BMS via set schedule (nights and weekends). Operator is to be able to override mode to occupied.

END OF SECTION 23 0900

SECTION 23 2113

HYDRONIC PIPING

PART 1 - GENERAL

1.1 RELATED DOCUMENTS

- A. Drawings and general provisions of the Contract, including General and Supplementary Conditions and Division 01 Specification Sections, apply to this Section.

1.2 SUMMARY

- A. Section includes pipe and fitting materials and joining methods for the following:
 1. Hot-water heating piping.
 2. Chilled-water piping.
 3. Condenser-water piping.
 4. Makeup-water piping.
 5. Condensate-drain piping.
 6. Air-vent piping.
 7. Dielectric fittings.

1.3 SEISMIC REQUIREMENTS

- A. All other components shall be assigned a component importance factor, I_p , equal to 1.0.
- B. Seismic Performance: Pipe hangers and supports shall withstand the effects of earthquake motions determined according to SEI/ASCE 7 and with the requirements specified in Division 23 Section "Vibration and Seismic Controls for HVAC."
 1. For piping with a seismic importance factor of 1.0 the term "withstand" means "the system will remain in place without separation of any parts when subjected to the seismic forces specified."
 2. For piping with a seismic importance factor of 1.5 the term "withstand" means "the system will remain in place without separation of any parts when subjected to the seismic forces specified and the system will be fully operational after the seismic event."

1.4 ACTION SUBMITTALS

- A. Product Data: For each type of the following:
 1. Steel pipe and fittings.
 2. Copper pipe, tubing and fittings.
 3. Dielectric fittings.
- B. LEED Submittals:
 1. Product Data for Credit IEQ 4.1: For solvent cements and adhesive primers, documentation including printed statement of VOC content.

2. Laboratory Test Reports for Credit IEQ 4.1: For solvent cements and adhesive primers, documentation indicating that products comply with the testing and product requirements of the California Department of Public Health's (formerly, the California Health Services') "Standard Method for the Testing and Evaluation of Volatile Organic Chemical Emissions from Indoor Sources Using Environmental Chambers."

C. Delegated-Design Submittal:

1. Design calculations and detailed fabrication and assembly of pipe anchors and alignment guides, hangers and supports for multiple pipes, expansion joints and loops, and attachments of the same to the building structure.
2. Locations of pipe anchors and alignment guides and expansion joints and loops.
3. Locations of and details for penetrations, including sleeves and sleeve seals for exterior walls, floors, basement, and foundation walls.

1.5 INFORMATIONAL SUBMITTALS

- A. Coordination Drawings: Piping layout, drawn to scale, on which the following items are shown and coordinated with each other, using input from installers of the items involved:
1. Suspended ceiling components.
 2. Other building services.
 3. Structural members.
- B. Qualification Data: For Installer.
- C. Welding certificates.
- D. Field quality-control reports: Written reports as specified in Part 3 of this section including:
1. Test procedures used.
 2. Test results showing compliance with specified requirements.
 3. Failed test results with corrective action taken to achieve compliance with specified requirements.

1.6 QUALITY ASSURANCE

- A. Steel Support Welding: Qualify procedures and personnel according to AWS D1.1/D1.1M, "Structural Welding Code - Steel."
- B. Pipe Welding: Qualify procedures and operators according to ASME Boiler and Pressure Vessel Code: Section IX.
1. Comply with ASME B31.9, "Building Services Piping," for materials, products, and installation.
 2. Certify that each welder has passed AWS qualification tests for welding processes involved and that certification is current.

1.7 COORDINATION

- A. Coordinate layout and installation of hydronic piping and suspension system components with other construction, including light fixtures, HVAC equipment, fire-suppression-system components, and partition assemblies.
- B. Coordinate pipe sleeve installations for foundation wall penetrations.

- C. Coordinate piping installation with roof curbs, equipment supports, and roof penetrations. Roof specialties are specified in Division 07 Sections.
- D. Coordinate pipe fitting pressure classes with products specified in related sections.
- E. Coordinate size and location of concrete bases. Cast anchor-bolt inserts into base. Concrete, reinforcement, and formwork requirements are specified in Division 03 Sections.
- F. Coordinate installation of pipe sleeves for penetrations through exterior walls and floor assemblies. Coordinate with requirements for firestopping specified in Division 07 Section "Penetration Firestopping" for fire and smoke wall and floor assemblies.

PART 2 - PRODUCTS

2.1 COPPER TUBE AND FITTINGS

- A. Drawn-Temper Copper Tubing: ASTM B 88, Type L.
- B. Grooved, Mechanical-Joint, Wrought-Copper Fittings: ASME B16.22.
 - 1. Grooved-End Copper Fittings: ASTM B 75, copper tube or ASTM B 584, bronze casting.
 - 2. Grooved-End-Tube Couplings: Coupling housings shall be cast with offsetting, angle-pattern bolt pads to provide joint rigidity and support and hanging in accordance with ANSI B31.1 and B31.9. Ductile-iron housing with keys matching pipe and fitting grooves, EPDM gasket rated for minimum 230 deg F without use of special lubricants. For use with housing, and ASTM A449 electroplated steel nuts and bolts.

2.2 STEEL PIPE AND FITTINGS

- A. Steel Pipe: ASTM A 53, black steel with plain ends; welded and seamless, Grade B, and wall thickness as indicated in "Piping Applications" Article.
- B. Cast-Iron Threaded Fittings: ASME B16.4; Classes 125 and 250 as indicated in "Piping Applications" Article.
- C. Malleable-Iron Threaded Fittings: ASME B16.3, Classes 150 and 300 as indicated in "Piping Applications" Article.
- D. Malleable-Iron Unions: ASME B16.39; Classes 150, 250, and 300 as indicated in "Piping Applications" Article.
- E. Cast-Iron Pipe Flanges and Flanged Fittings: ASME B16.1, Classes 25, 125, and 250; raised ground face, and bolt holes spot faced as indicated in "Piping Applications" Article.
- F. Wrought-Steel Fittings: ASTM A 234, wall thickness to match adjoining pipe.
- G. Wrought Cast- and Forged-Steel Flanges and Flanged Fittings: ASME B16.5, including bolts, nuts, and gaskets of the following material group, end connections, and facings:
 - 1. Material Group: 1.1.
 - 2. End Connections: Butt welding.
 - 3. Facings: Raised face.
- H. Forged Steel "Olet" Type Fittings, Welding, Socket-Welding and Threaded: ASME B16.11 and ASTM A105.

1. Welding Filler Metals: Comply with AWS D10.12M/D10.12 for welding materials appropriate for wall thickness and chemical analysis of steel pipe being welded.
- I. Steel Pipe Nipples: ASTM A 733, made of same materials and wall thicknesses as pipe in which they are installed.
 - J. Grooved Mechanical-Joint Fittings and Couplings:
 1. Manufacturers: Subject to compliance with requirements, provide products by the following provide products by one of the following:
 - a. Victaulic Company.
 - b. Anvil International, Inc.
 - c. Tyco-Grinnel
 2. Joint Fittings: ASTM A 536, Grade 65-45-12 ductile iron; ASTM A 53, Type F, E, or S, Grade B factory-fabricated steel; or ASTM A 234, Grade WPB steel fittings with grooves or shoulders designed and constructed to accept grooved-end couplings.
 3. Couplings: Two Ductile- housing and synthetic rubber gasket of central cavity pressure-responsive design; with ASTM A449 electroplated steel nuts and bolts to secure grooved pipe and fittings. Couplings shall comply with ASTM F1476 Standard Specification for the Performance of Gasketed Mechanical Couplings for Use in Piping Applications.
 - a. Rigid Type: Coupling housings shall be cast with offsetting, angle-pattern bolt pads to provide joint rigidity and support and hanging in accordance with ANSI B31.1 and B31.9.
 - b. Gasket: High temperature EPDM gasket, suitable for water service to +250 deg F, without use of special lubricants.
 - c. Flexible Type: For use in locations where vibration attenuation and stress relief are required, and for the elimination of flexible connectors.
 - d. 14" and Larger: Two –segment coupling, with lead-in chamfer on housing key and a wide-width gasket having a center-leg.
 4. Combinations of grooved mechanical-joint couplings and short nipples may also be used.

2.3 JOINING MATERIALS

- A. Pipe-Flange Gasket Materials: Suitable for chemical and thermal conditions of piping system contents.
 1. ASME B16.21, nonmetallic, flat, asbestos free, 1/8-inch (3.2-mm) maximum thickness unless otherwise indicated.
 - a. Full-Face Type: For flat-face, Class 125, cast-iron and cast-bronze flanges.
 - b. Narrow-Face Type: For raised-face, Class 250, cast-iron and steel flanges.
- B. Flange Bolts and Nuts: ASME B18.2.1, carbon steel, unless otherwise indicated.
- C. Solder Filler Metals: ASTM B 32, lead-free alloys. Include water-flushable flux according to ASTM B 813.
- D. Brazing Filler Metals: AWS A5.8, BCuP Series, copper-phosphorus alloys for joining copper with copper; or BAg-1, silver alloy for joining copper with bronze or steel. Use of flux is required in all brazing applications. The flux used is to be a black brazing flux that does not contain boric acid and conforms to AWS A5.31 class FB3-C.
- E. Welding Filler Metals: Comply with AWS D10.12M/D10.12 for welding materials appropriate for wall thickness and chemical analysis of steel pipe being welded.

2.4 DIELECTRIC FITTINGS

- A. General: Assembly or fitting with insulating material isolating joined dissimilar metals, to prevent galvanic action and stop corrosion.
 - 1. Manufacturers:
 - a. Advance Products & Systems, Inc.
 - b. Calpico, Inc. Capitol Manufacturing Co.
 - c. Capitol Manufacturing Company.
 - d. Central Plastics Company.
 - e. Elster Perfection.
 - f. Grinnell Mechanical Products.
 - g. Matco-Norca.
 - h. Pipeline Seal and Insulator, Inc.
 - i. Precision Plumbing Products, Inc.
 - j. Victaulic Company.
 - k. Watts Regulator Co.
 - l. Zurn Industries, LLC.
- B. Description: Combination of copper alloy and ferrous; threaded, solder, plain, and weld-neck end types and matching piping system materials.
- C. Insulating Material: Suitable for system fluid, pressure, and temperature.
- D. End Connections: Threaded, or flanged.
- E. Dielectric Couplings: Galvanized-steel coupling with inert and noncorrosive, thermoplastic lining; threaded ends; and 300-psig minimum working pressure at 225 deg F.
- F. Dielectric Nipples or Waterways: Electroplated steel with inert and noncorrosive, thermoplastic lining; plain, threaded, or grooved ends; and 300-psig minimum working pressure at 225 deg F.

PART 3 - EXECUTION

3.1 PIPING APPLICATIONS

- A. Hot-water heating piping, aboveground, NPS 2 and smaller shall be any of the following:
 - 1. Type L drawn-temper copper tubing, wrought-copper fittings, and soldered joints.
 - 2. Schedule 40, Grade B, Type 96 steel pipe; Class 125, cast-iron fittings; cast-iron flanges and flange fittings; and threaded joints.
- B. Hot-water heating piping, aboveground, NPS 2-1/2 and larger, shall be any of the following:
 - 1. Type L, drawn-temper copper tubing, wrought-copper fittings, and soldered joints.
 - 2. Schedule 40 steel pipe, wrought-steel fittings and wrought-cast or forged-steel flanges and flange fittings, and welded and flanged joints.
 - 3. Schedule 40 steel pipe; grooved, mechanical joint coupling and fittings; and grooved, mechanical joints.
- C. Chilled-water piping, aboveground, NPS 2 and smaller, shall be any of the following:
 - 1. Type L, drawn-temper copper tubing, wrought-copper fittings, and soldered joints.
 - 2. Schedule 40, Grade B, Type 96 steel pipe; Class 125, cast-iron fittings; cast-iron flanges and flange fittings; and threaded joints.

- D. Chilled-water piping, aboveground, NPS 2-1/2 and larger, shall be any of the following:
1. Type L, drawn-temper copper tubing, wrought-copper fittings, and soldered joints.
 2. Schedule 40 steel pipe, wrought-steel fittings and wrought-cast or forged-steel flanges and flange fittings, and welded and flanged joints.
 3. Schedule 40 steel pipe; grooved, mechanical joint coupling and fittings; and grooved, mechanical joints.
- E. Condenser-water piping, aboveground, NPS 2 and smaller, shall be any of the following:
1. Type L, drawn-temper copper tubing, wrought-copper fittings, and soldered joints.
 2. Schedule 40, Grade B, Type 96 steel pipe; Class 125, cast-iron fittings; cast-iron flanges and flange fittings; and threaded joints.
- F. Condenser-water piping, aboveground, NPS 2-1/2 and larger, shall be any of the following:
1. Type L, drawn-temper copper tubing, wrought-copper fittings, and soldered joints.
 2. Schedule 40 steel pipe, wrought-steel fittings and wrought-cast or forged-steel flanges and flange fittings, and welded and flanged joints.
 3. Schedule 40 steel pipe; grooved, mechanical joint coupling and fittings; and grooved, mechanical joints.
- G. Condenser-water piping installed belowground and within slabs shall be **any of** the following:
1. Type K, annealed-temper copper tubing, wrought-copper fittings, and **brazed** joints. Use the fewest possible joints.
 2. PP, SDR 7.4 pipe; fusion socket fittings; and fusion joints or butt-fusion joints.
 3. PP, SDR 11 fiberglass composite reinforced pipe; fusion socket fittings; and fusion joints or butt-fusion joints.
 4. RTRP and RTRF with adhesive or flanged joints.
- H. Glycol cooling-water piping, aboveground, NPS 2 and smaller, shall be any of the following:
1. Type L, drawn-temper copper tubing, wrought-copper fittings, and soldered joints.
 2. Schedule 40, Grade B, Type 96 steel pipe; Class 125, cast-iron fittings; cast-iron flanges and flange fittings; and threaded joints.
- I. Glycol cooling-water piping, aboveground, NPS 2-1/2 and larger, shall be any of the following:
1. Type L, drawn-temper copper tubing, wrought-copper fittings, and soldered joints.
 2. Schedule 40 steel pipe, wrought-steel fittings and wrought-cast or forged-steel flanges and flange fittings, and welded and flanged joints.
 3. Schedule 40 steel pipe; grooved, mechanical joint coupling and fittings; and grooved, mechanical joints.
- J. Makeup-water piping installed aboveground shall be the following:
1. Type L, drawn-temper copper tubing, wrought-copper fittings, and soldered joints.
- K. Condensate-drain piping shall be the following:
1. Type M, drawn-temper copper tubing, wrought-copper fittings, and soldered joints.
- L. Blowdown-Drain Piping: Same materials and joining methods as for piping specified for the service in which blowdown drain is installed.

- M. Air-Vent Piping:
1. Inlet: Same as service where installed with metal-to-plastic transition fittings for plastic piping systems according to piping manufacturer's written instructions.
 2. Outlet: Type K, annealed-temper copper tubing with soldered or flared joints.
- N. Safety-Valve-Inlet and -Outlet Piping for Hot-Water Piping: Same materials and joining methods as for piping specified for the service in which safety valve is installed with metal-to-plastic transition fittings for plastic piping systems according to piping manufacturer's written instructions.

3.2 PIPING INSTALLATIONS

A. PRE-WORK / PRE-REQUISITES

1. Drawing plans, schematics, and diagrams indicate general location and arrangement of piping systems. Install piping as indicated unless deviations to layout are approved on Coordination Drawings.
2. The Contractor shall study the architectural, structural, mechanical, electrical and other drawings to eliminate conflict of piping with other structure lighting or other services.

B. CONDITION

1. All installed pipe lines shall be free from dents, scars, and burrs, with ends reamed smooth.
2. All piping shall be clean and free from acids and loose dirt when installed and shall be kept clean during the completion of the installation.
3. Install piping free of sags and bends.
4. All installed pipe lines shall remain straight against strains tending to cause distortion during system operation. The contractor shall make proper allowance for pipe line expansion and contraction so that no unsightly distortion, noise, damage or improper operation results therefrom.

C. SELECTION

1. Select system components with pressure rating equal to or greater than system operating pressure.
2. No street type fittings shall be used.
3. No short nipples shall be used except at drain valves.
4. Plugs of rags, wools, cottons, waste, or similar materials may not be used for plugging.

D. ROUTING/ARRANGEMENT

1. Piping installations shall be neatly organized.
2. Install piping in concealed locations unless otherwise indicated and except in equipment rooms and service areas.
3. Install groups of pipes parallel to each other.

4. Install piping spaced to permit application of insulation.
5. Install piping parallel and spaced to permit the servicing of valves.
6. Install piping indicated to be exposed and piping in equipment rooms and service areas at right angles or parallel to building walls or axis of the building.
7. Diagonal runs are prohibited unless specifically indicated otherwise.
8. Install fittings for all changes in direction.
9. No piping shall be run above any electrical panels, electrical equipment or access clearances for electrical for electrical panels or equipment. No piping shall be allowed to run through any electrical rooms.
10. Piping shall be arranged, placed and installed to facilitate equipment maintenance and shall be so arranged to not interfere with the installation of the air-conditioning equipment, ducts, or the removal of other equipment or devices. All specialties shall be so placed to permit easy operation and access.
11. All piping shall be so installed to insure noiseless circulation.
12. Install fittings for all branch connections.
13. Unless otherwise indicated, install branch connections to mains using [mechanically formed] tee fittings or forged steel branch fittings in main pipe, with the branch connected to the bottom of the main pipe.
14. For up-feed risers, connect the branch to the top of the main pipe.
15. Forged branch fittings shall be installed per the manufacturer's recommendations.

E. ACCESS / ARRANGEMENT

1. Install piping above accessible ceilings to allow sufficient space for ceiling panel removal. All piping shall be so arranged to not block access to manholes, access openings, etc.
2. Install piping at indicated slopes. If not indicated, install piping at a uniform grade of 0.2 percent where possible, upward in direction of flow. Traps are to be avoided where-ever possible.
3. Reduce pipe sizes using eccentric reducer fitting installed with level side up.
4. When insulated pipes are supported by a roller hanger they shall be protected from damage by suitable pipe covering protection saddles. Saddles shall support pipe on roller and shall be packed with insulation.
5. Install valves according to Division 23 Section "General-Duty Valves for HVAC Piping."
6. Install unions in piping, NPS 2 and smaller, adjacent to valves, at final connections of equipment, at each coil on all sides of automatic valves where valves do not have union connections, elsewhere as indicated, and wherever necessary to prevent undue difficulty in making repairs or replacement. Unions are not required at flanged connections.
7. Install flanges in piping, NPS 2-1/2 and larger, at final connections of equipment and elsewhere as indicated. Install flanges on valves, apparatus, and equipment having 2 1/2 inch NPS and larger connections. Flanges or unions as applicable for the type of piping specified, shall be provided in the piping at connections to all items of equipment.

8. Install shutoff valve immediately upstream of each dielectric fitting. Install dielectric coupling and nipple fittings to connect piping materials of dissimilar metals.
9. Comply with requirements in Division 23 Section "Expansion Fittings and Loops for HVAC Piping" for installation of expansion loops, expansion joints, anchors, and pipe alignment guides. Anchor piping for proper direction of expansion and contraction.
10. Install sleeves for piping penetrations of walls, ceilings, and floors. Comply with requirements for sleeves specified in Division 23 Section "Sleeves and Sleeve Seals for HVAC Piping."
11. Install sleeve seals for piping penetrations of concrete walls and slabs. Comply with requirements for sleeve seals specified in Division 23 Section "Sleeves and Sleeve Seals for HVAC Piping."
12. Install escutcheons for piping penetrations of walls, ceilings, and floors. Comply with requirements for escutcheons specified in Division 23 Section "Escutcheons for HVAC Piping."
13. Install strainers on supply side of each control valve, pressure-reducing valve, solenoid valve, in-line pump, and elsewhere as indicated. Install NPS ¾) nipple and ball valve in blow-down connection of strainers NPS 2) and larger. Match size of strainer blow-off connection for strainers smaller than NPS 2).
14. Install flexible connectors at inlet and discharge connections to pumps (except inline pumps) and other vibration-producing equipment.
15. Polypropylene pipe in or passing through plenums must be fire wrapped or installed in a metal conduit.

F. DRAINAGE

1. Drain valves shall be installed at all low points in all piping systems to allow for complete drainage of piping systems.
2. Install drains, consisting of a tee fitting, NPS 3/4 ball valve, and short NPS 3/4 threaded nipple with cap, at low points in piping system mains and elsewhere as required for system drainage.
3. All piping systems shall be installed so that they can be easily drained by means of drainage of low points of all piping without disconnecting pipe.
4. If not specifically indicated on the drawings, the frequency of draining shall determine whether drain caps, plugs, cocks, or valves are to be used.

G. IDENTIFICATION

1. Comply with requirements in Division 23 Section "Identification for HVAC Piping and Equipment" for identifying piping.

3.3 DIELECTRIC FITTING INSTALLATION

A. Make connections according to the following, unless otherwise indicated:

1. Install dielectric nipples or waterways in piping NPS 2 and smaller, adjacent to each valve and at final connection to each piece of equipment.

2. Install waterways, in piping NPS 2-1/2 and larger, adjacent to flanged valves and at final connection to each piece of equipment.
3. Install Dielectric Fittings into Hydronic Piping Systems: Install dielectric nipples, waterways or couplings to connect piping materials of dissimilar metals.
4. End Connections: Threaded, or flanged.

3.4 HANGERS AND SUPPORTS

- A. Comply with requirements in Division 23 Section "Hangers and Supports for HVAC Piping and Equipment" for hanger, support, and anchor devices. Comply with the following requirements for maximum spacing of supports.
- B. Comply with requirements in Division 23 Section "Vibration and Seismic Controls for HVAC" for seismic restraints.
- C. Steel roof deck shall not be used to support loads from piping, ductwork or equipment, unless noted otherwise. Hanger loads less than 50 lbs. may be hung from the steel roof deck in cases when hanging from the steel roof deck cannot be avoided; the attachment method must distribute the load across the deck as approved by the Structural Engineer.
- D. Install the following pipe attachments:
 1. Adjustable steel clevis hangers for individual horizontal piping less than 20 feet long.
 2. Adjustable roller hangers and spring hangers for individual horizontal piping 20 feet or longer.
 3. Pipe Roller: MSS SP-58, Type 44 for multiple horizontal piping 20 feet or longer, supported on a trapeze.
 4. Spring hangers to support vertical runs.
 5. Provide copper-clad hangers and supports for hangers and supports in direct contact with copper pipe.
 6. On plastic pipe, install pads or cushions on bearing surfaces to prevent hanger from scratching pipe.
- E. Install hangers for steel piping with the following maximum spacing and minimum rod sizes:
 1. NPS 3/4: Maximum span, 7 feet; minimum rod size, 3/8 inch.
 2. NPS 1: Maximum span, 7 feet; minimum rod size, 3/8 inch.
 3. NPS 1-1/2: Maximum span, 9 feet; minimum rod size, 3/8 inch.
 4. NPS 2: Maximum span, 10 feet; minimum rod size, 3/8 inch.
 5. NPS 2-1/2: Maximum span, 11 feet; minimum rod size, 1/2 inch.
 6. NPS 3 and Larger: Maximum span, 12 feet; minimum rod size, 1/2 inch.
- F. Install hangers for drawn-temper copper piping with the following maximum spacing and minimum rod sizes:
 1. NPS 3/4: Maximum span, 5 feet; minimum rod size, 1/4 inch.
 2. NPS 1: Maximum span, 6 feet; minimum rod size, 1/4 inch.
 3. NPS 1-1/4: Maximum span, 7 feet; minimum rod size, 3/8 inch.
 4. NPS 1-1/2: Maximum span, 8 feet; minimum rod size, 3/8 inch.
 5. NPS 2: Maximum span, 8 feet; minimum rod size, 3/8 inch.
 6. NPS 2-1/2: Maximum span, 9 feet; minimum rod size, 3/8 inch.
 7. NPS 3 and Larger: Maximum span, 10 feet; minimum rod size, 3/8 inch.
- G. Fiberglass Piping Hanger Spacing: Space hangers according to pipe manufacturer's written instructions for service conditions. Avoid point loading. Space and install hangers with the fewest practical rigid anchor points.

- H. Support vertical runs at roof, at each floor, and at 10-foot intervals between floors.
- I. Support piping and tubing not listed in this article according to MSS SP-69 and manufacturer's written instructions.

3.5 PIPE JOINT CONSTRUCTION

- A. Ream ends of pipes and tubes and remove burrs. Bevel plain ends of steel pipe.
- B. Remove scale, slag, dirt, and debris from inside and outside of pipe and fittings before assembly.
- C. Soldered Joints: Apply ASTM B 813, water-flushable flux, unless otherwise indicated, to tube end. Construct joints according to ASTM B 828 or CDA's "Copper Tube Handbook," using lead-free solder alloy complying with ASTM B 32.
- D. Brazed Joints: Construct joints according to AWS's "Brazing Handbook," "Pipe and Tube" Chapter, using copper-phosphorus brazing filler metal complying with AWS A5.8.
- E. Threaded Joints: Thread pipe with tapered pipe threads according to ASME B1.20.1. Cut threads full and clean using sharp dies. Ream threaded pipe ends to remove burrs and restore full ID. Join pipe fittings and valves as follows:
 - 1. Apply appropriate tape or thread compound to external pipe threads unless dry seal threading is specified.
 - 2. Damaged Threads: Do not use pipe or pipe fittings with threads that are corroded or damaged. Do not use pipe sections that have cracked or open welds.
- F. Welded Joints: Construct joints according to AWS D10.12M/D10.12, using qualified processes and welding operators according to "Quality Assurance" Article.
- G. Flanged Joints: Select appropriate gasket material, size, type, and thickness for service application. Install gasket concentrically positioned. Use suitable lubricants on bolt threads.
- H. Grooved Joints: Assemble joints with coupling and gasket, lubricant, and bolts.
 - 1. Cut or roll grooves in ends of pipe based on pipe and coupling manufacturer's written instructions for pipe wall thickness. Use grooved-end fittings and rigid, grooved-end-pipe couplings.
 - 2. Installed in accordance with the manufacturer's written recommendations.
 - 3. Ends shall be clean and free from indentations, projections or roll marks.
 - 4. The gasket shall be molded and produced by the coupling manufacturer of an elastomer suitable for the intended service.
 - 5. Unions and flanges for servicing and disconnect are not required in installations using grooved joint couplings.
 - 6. Training: The coupling manufacturer's factory-direct trained representative shall provide on-site training for the contractor's field personnel in the use of grooving tools and installation of product. The representative shall periodically visit the job site to ensure best practices in grooved product installation are being followed. The distributor's representative will not be acceptable.

3.6 TERMINAL EQUIPMENT CONNECTIONS

- A. Sizes for supply and return piping connections shall be the same as or larger than equipment connections.
- B. Install control valves in accessible locations close to connected equipment.

3.7 FIELD QUALITY CONTROL

- A. Prepare hydronic piping according to ASME B31.9 and as follows:
1. Leave joints, including welds, uninsulated and exposed for examination during test.
 2. Provide temporary restraints for expansion joints that cannot sustain reactions due to test pressure. If temporary restraints are impractical, isolate expansion joints from testing.
 3. Flush hydronic piping systems with clean water; then remove and clean or replace strainer screens.
 4. Isolate equipment from piping. If a valve is used to isolate equipment, its closure shall be capable of sealing against test pressure without damage to valve. Install blinds in flanged joints to isolate equipment.
 5. Install safety valve, set at a pressure no more than one-third higher than test pressure, to protect against damage by expanding liquid or other source of overpressure during test.
- B. Perform the following tests on hydronic piping:
1. Use ambient temperature water as a testing medium unless there is risk of damage due to freezing. Another liquid that is safe for workers and compatible with piping may be used.
 2. While filling system, use vents installed at high points of system to release air. Use drains installed at low points for complete draining of test liquid.
 3. Isolate expansion tanks and determine that hydronic system is full of water.
 4. Subject piping system to hydrostatic test pressure that is not less than 1.5 times the system's working pressure. Test pressure shall not exceed maximum pressure for any vessel, pump, valve, or other component in system under test. Verify that stress due to pressure at bottom of vertical runs does not exceed 90 percent of specified minimum yield strength or 1.7 times the "SE" value in Appendix A in ASME B31.9, "Building Services Piping."
 5. After hydrostatic test pressure has been applied for at least 10 minutes, examine piping, joints, and connections for leakage. Eliminate leaks by tightening, repairing, or replacing components, and repeat hydrostatic test until there are no leaks.
 6. Prepare written report of testing.
- C. Perform the following before operating the system:
1. Open manual valves fully.
 2. Inspect pumps for proper rotation.
 3. Set makeup pressure-reducing valves for required system pressure.
 4. Inspect air vents at high points of system and determine if all are installed and operating freely (automatic type), or bleed air completely (manual type).
 5. Set temperature controls so all coils are calling for full flow.
 6. Inspect and set operating temperatures of hydronic equipment, such as boilers, chillers, cooling towers, to specified values.
 7. Verify lubrication of motors and bearings.

END OF SECTION 23 2113

SECTION 23 2116

HYDRONIC PIPING SPECIALTIES

PART 1 - GENERAL

1.1 RELATED DOCUMENTS

- A. Drawings and general provisions of the Contract, including General and Supplementary Conditions and Division 01 Specification Sections, apply to this Section.

1.2 SUMMARY

- A. Section includes special-duty valves and specialties for the following: Hot-water heating piping.
 1. Chilled-water piping.
 2. Condenser-water piping.
 3. Makeup-water piping.
 4. Condensate-drain piping.
 5. Air-vent piping.
 6. Steel, hydronic buffer tanks.

1.3 ACTION SUBMITTALS

- A. Product Data: For each type of the following:
 1. Valves: Include flow and pressure drop curves based on manufacturer's testing for calibrated-orifice balancing valves and automatic flow-control valves.
 2. Air-control devices.
 3. Hydronic specialties.

1.4 CLOSEOUT SUBMITTALS

- A. Operation and Maintenance Data: For air-control devices, hydronic specialties, and special-duty valves to include in emergency, operation, and maintenance manuals.

1.5 QUALITY ASSURANCE

- A. Pipe Welding: Qualify procedures and operators according to ASME Boiler and Pressure Vessel Code: Section IX.
 1. Safety valves and pressure vessels shall bear the appropriate ASME label. Fabricate and stamp air separators and expansion tanks to comply with ASME Boiler and Pressure Vessel Code: Section VIII, Division 1.

PART 2 - PRODUCTS

2.1 VALVES

- A. Globe, Check, Ball, and Butterfly Valves: Comply with requirements specified in Division 23 Section "General-Duty Valves for HVAC Piping." Gate valves are not allowed on this project.

- B. Automatic Temperature-Control Valves, Actuators, and Sensors: Comply with requirements specified in Division 23 Section "Instrumentation and Control for HVAC."
- C. Refer to Part 3 "Valve Applications" Article for applications of each valve.
- D. Bronze, Calibrated-Orifice or Venturi, Balancing Valves, NPS 2 and smaller:
 - 1. Manufacturers: Subject to compliance with requirements, provide products by one of the following:
 - a. Armstrong Pumps, Inc.
 - b. Bell & Gossett Domestic Pump.
 - c. Flow Design Inc.
 - d. Gerand Engineering Co.
 - e. Griswold Controls.
 - f. Taco.
 - g. Tour & Andersson; available through Victaulic Company.
 - h. Tyco-Grinnell
 - 2. Body: Bronze, ball or plug type with calibrated orifice or venturi.
 - 3. Ball: Brass or stainless steel.
 - 4. Plug: Resin.
 - 5. Seat: PTFE.
 - 6. End Connections: Threaded or socket.
 - 7. Pressure Gage Connections: Integral seals for portable differential pressure meter.
 - 8. Handle Style: Lever, with memory stop to retain set position.
 - 9. CWP Rating: Minimum 125 psig.
 - 10. Maximum Operating Temperature: 250 deg F.
- E. Cast-Iron or Steel, Calibrated-Orifice or Venturi, Balancing Valves, NPS 2 ½ and larger:
 - 1. Manufacturers: Subject to compliance with requirements, provide products by one of the following:
 - a. Amtrol, Inc.
 - b. Armstrong Pumps, Inc.
 - c. Bell & Gossett Domestic Pump.
 - d. Flow Design Inc.
 - e. Gerand Engineering Co.
 - f. Grinnell.
 - g. Griswold Controls.
 - h. Taco.
 - i. Tour & Andersson; available through Victaulic Company.
 - j. Spence Engineering Company Inc.
 - k. Watts Regulator Co.
 - 2. Body: Cast-iron or steel body, ball, plug, or globe pattern with calibrated orifice or venturi.
 - 3. Ball: Brass or stainless steel.
 - 4. Stem Seals: EPDM O-rings.
 - 5. Disc: Glass and carbon-filled PTFE.
 - 6. Seat: PTFE.
 - 7. End Connections: Flanged or grooved.
 - 8. Pressure Gage Connections: Integral seals for portable differential pressure meter.
 - 9. Handle Style: Lever, with memory stop to retain set position.

10. CWP Rating: Minimum 125 psig.
11. Maximum Operating Temperature: 250 deg F.

F. Diaphragm-Operated, Pressure-Reducing Valves: ASME labeled.

1. Manufacturers: Subject to compliance with requirements, provide products by one of the following:
 - a. Amtrol, Inc.
 - b. Armstrong Pumps, Inc.
 - c. Bell & Gossett Domestic Pump.
 - d. Conbraco Industries, Inc.
 - e. Spence Engineering Company, Inc.
 - f. Watts Regulator Co.
2. Body: Bronze or brass.
3. Disc: Glass and carbon-filled PTFE.
4. Seat: Brass.
5. Stem Seals: EPDM O-rings.
6. Diaphragm: EPT.
7. Low inlet-pressure check valve.
8. Inlet Strainer: Brass, removable without system shutdown.
9. Valve Seat and Stem: Noncorrosive.
10. Valve Size, Capacity, and Operating Pressure: Selected to suit system in which installed, with operating pressure and capacity factory set and field adjustable.

G. Diaphragm-Operated Safety Valves: ASME labeled.

1. Manufacturers: Subject to compliance with requirements, provide products by one of the following:
 - a. Amtrol, Inc.
 - b. Armstrong Pumps, Inc.
 - c. Bell & Gossett Domestic Pump.
 - d. Conbraco Industries, Inc.
 - e. Kunkle.
 - f. Spence Engineering Company, Inc.
2. Body: Bronze or brass.
3. Disc: Glass and carbon-filled PTFE.
4. Seat: Brass.
5. Stem Seals: EPDM O-rings.
6. Diaphragm: EPT.
7. Wetted, Internal Work Parts: Brass and rubber.
8. Inlet Strainer: Brass, removable without system shutdown.
9. Valve Seat and Stem: Noncorrosive.
10. Valve Size, Capacity, and Operating Pressure: Comply with ASME Boiler and Pressure Vessel Code: Section IV, and selected to suit system in which installed, with operating pressure and capacity factory set and field adjustable.

H. Automatic Flow-Control Valves:

1. Manufacturers: Subject to compliance with requirements, provide products by one of the following:
 - a. Armstrong Pumps, Inc.
 - b. Bell & Gossett Domestic Pump.

- c. Flow Design Inc.
 - d. Griswold Controls.
 - e. Taco
 - f. Nexus.
2. Body: Brass or ferrous metal.
 3. Piston and Spring Assembly: Tamper proof, self-cleaning, and removable, for inspections and replacement.
 - a. Corrosion resistant.
 4. Combination Assemblies: Include bronze or brass-alloy ball valve.
 5. Identification Tag: Attached by chain and marked with zone identification, valve number, and flow rate.
 6. Size: Same as pipe in which installed.
 7. Performance: Maintain constant flow, plus or minus 5 percent over system pressure fluctuations:
 - a. Minimum CWP Rating: 175 psig.
 8. Maximum Operating Temperature: 200 deg F.
 9. Fitted with pressure and temperature test valves.
 10. Equipped with a readout kit including flow meter, probes, hoses, flow charts, and carrying case.

2.2 AIR-CONTROL DEVICES

A. Manual Air Vents:

1. Manufacturers: Subject to compliance with requirements, provide products by one of the following:
 - a. Amtrol, Inc.
 - b. Armstrong Pumps, Inc.
 - c. Bell & Gossett Domestic Pump.
 - d. Taco, Inc.
2. Body: Bronze.
3. Internal Parts: Nonferrous.
4. Operator: Screwdriver or thumbscrew.
5. Manually operated with ball valve in the down position.
6. Inlet Connection: NPS 1/2.
7. Discharge Connection: NPS 1/8.
8. CWP Rating: 150 psig.
9. Maximum Operating Temperature: 225 deg F.

B. Automatic Air Vents:

1. Manufacturers: Subject to compliance with requirements, provide products by one of the following:
 - a. Amtrol, Inc.
 - b. Bell & Gossett Domestic Pump.
 - c. Hoffman Specialty ITT; Fluid Handling Div.
 - d. Spirax-Sarco.
 - e. Spirovent.
 - f. Taco, Inc.

- g. Honeywell-Baukman.
 - 2. Body: Bronze or cast iron.
 - 3. Internal Parts: Nonferrous.
 - 4. Operator: Noncorrosive metal float.
 - 5. Inlet Connection: NPS 1/2.
 - 6. Discharge Connection: NPS 1/4.
 - 7. CWP Rating: 150 psig.
 - 8. Maximum Operating Temperature: 240 deg F.
- C. Bladder -Type Expansion Tanks:
- 1. Manufacturers: Subject to compliance with requirements, provide products by one of the following:
 - a. Amtrol, Inc.
 - b. Armstrong Pumps, Inc.
 - c. Bell & Gossett Domestic Pump.
 - d. Taco, Inc.
 - e. Zilmet
 - 2. Tank: Welded steel, rated for 125-psig working pressure and 240 deg F maximum operating temperature. Factory test after taps are fabricated and supports installed and are labeled according to ASME Boiler and Pressure Vessel Code: Section VIII, Division 1.
 - 3. Bladder : Securely sealed into tank to separate air charge from system water to maintain required expansion capacity.
 - 4. Air-Charge Fittings: Schrader valve, stainless steel with EPDM seats.
 - 5. Access: Drain fitting and taps for pressure gage.
 - 6. Support:
 - a. Vertical tanks with steel legs or base.
 - b. Horizontal tanks with steel saddles.
- D. Tangential-Type Air Separators:
- 1. Manufacturers: Subject to compliance with requirements, provide products by one of the following:
 - a. Amtrol, Inc.
 - b. Armstrong Pumps, Inc.
 - c. Bell & Gossett Domestic Pump.
 - d. Taco, Inc.
 - 2. Tank: Welded steel; ASME constructed and labeled for 125-psig minimum working pressure and 240 deg F maximum operating temperature.
 - 3. Air Collector Tube: Perforated stainless steel, constructed to direct released air into expansion tank.
 - 4. Tangential Inlet and Outlet Connections: Threaded for NPS 2 and smaller; flanged connections for NPS 2-1/2 and larger.
 - 5. Blowdown Connection: Threaded.
 - 6. Size: Match system flow capacity.

2.3 HYDRONIC PIPING SPECIALTIES

A. Y-Pattern Strainers:

1. Manufacturers: Subject to compliance with requirements, provide products by one of the following:
 - a. Armstrong Machine Works.
 - b. Hoffman Specialty ITT; Fluid Handling Div.
 - c. Metraflex Co.
 - d. Mueller
 - e. Spirax Sarco.
 - f. Trane Co.
 - g. Tyco-Grinnell.
 - h. Tour & Andersson; available through Victaulic Company.
 - i. Watts Regulator Co.
2. Body: ASTM A 126, Class B, cast iron with bolted cover and bottom drain connection.
3. End Connections: Threaded ends for NPS 2 and smaller; flanged ends for NPS 2-1/2 and larger.
4. Strainer Screen: Stainless-steel, or perforated stainless-steel basket:
 - a. 20-mesh strainer.
5. CWP Rating: 125 psig.

B. Basket Strainers:

1. Manufacturers: Subject to compliance with requirements, provide products by one of the following:
 - a. Crane Co.
 - b. Metraflex Co.
 - c. Mueller
 - d. Spirax Sarco.
 - e. Tyco-Grinnell.
 - f. Tour & Andersson; available through Victaulic Company.
2. Body: ASTM A 126, Class B, high-tensile cast iron with bolted cover and bottom drain connection.
3. End Connections: Threaded ends for NPS 2 and smaller; flanged ends for NPS 2-1/2 and larger.
4. Strainer Screen: Perforated stainless-steel basket with 50 percent free area:
 - a. 40-mesh startup strainer.
5. CWP Rating: 125 psig.

C. Stainless-Steel Braided-Corrugated, Flexible Connectors:

1. Manufacturers: Subject to compliance with requirements, provide products by one of the following:
 - a. Amber-Booth.
 - b. Mason Industries.
 - c. Metraflex Co.
 - d. Flex-Weld.
 - e. Fugate.
 - f. Twin City Hose.
2. Body: 321 Stainless-steel close pitch corrugated hose with woven, flexible, 304 Stainless-steel, protective jacket.
3. End Connections: Flanged, ANSI Class 150 carbon steel

4. Performance: Permanent Offset; 3/8 inch, Intermittent Offset; 1/8 inch.
5. Safe Working Pressure: 175 psig. (For 8 inch diameter)
6. Maximum Operating Temperature: 200 deg F. (For 8 inch diameter)

D. Spherical, Rubber, Flexible Connectors:

1. Manufacturers: Subject to compliance with requirements, provide products by one of the following:
 - a. Amber-Booth.
 - b. Mason Industries.
 - c. Metraflex Co.
 - d. Flex-Weld.
 - e. Proco.
 - f. Fugate.
 - g. Twin City Hose.
2. Body: Double-sphere fiber-reinforced EPDM rubber body.
3. End Connections: Steel flanges drilled to align with Classes 150 and 300 steel flanges.
4. Performance: Capable of misalignment.
5. CWP Rating: 150 psig.
6. Maximum Operating Temperature: 250 deg F.

E. Diverting Fittings:

1. Manufacturers: Subject to compliance with requirements, provide products by one of the following:
 - a. Amtrol, Inc.
 - b. Armstrong Pumps, Inc.
 - c. Bell & Gossett Domestic Pump.
 - d. Taco, Inc.
2. Body: Cast Iron or Wrought Copper
3. Ends: Threaded or Soldered
4. Flow Direction: Indicated on fitting.
5. CWP Rating: 125 psig.
6. Maximum Operating Temperature: 250 deg F.

2.4 STEEL, HYDRONIC BUFFER TANKS

- A. Manufacturers: Subject to compliance with requirements, provide products by one of the following:
 1. Hanson Tank
 2. Lochinvar Corporation.
 3. Taco Comfort Solutions
 4. Smith, A. O. Water Products Co.; a division of A. O. Smith Corporation.
 5. Weben-Jarco, Inc.
 6. Wessels Company.
- B. Description: Steel, horizontal or vertical buffer tank, pressure-rated tank with cylindrical sidewalls. See drawings for tank type.
- C. Fabricate supports and attachments to tank with reinforcement strong enough to resist tank movement during seismic event when tank supports are anchored to building structure.

- D. Construction:
 - 1. ASME Boiler and Pressure Vessels Code Section VIII code, steel, constructed with welded joints, 450°F temperature and a pressure rating of:
 - a. 125 PSIG
- E. Manhole: Watertight, for tank more than 36 inches in diameter; same pressure rating as tank.
- F. Tappings: Factory-fabricated, welded to tank before testing and labeling.
 - 1. Hot water buffer tanks shall have four tappings.
 - a. NPS 2 and Smaller: ASME B1.20.1, with female thread.
 - b. NPS 2-1/2 and Larger: ASME B16.5, flanged.
 - 2. Chilled water buffer tanks shall have two tappings.
 - a. NPS 2 and Smaller: ASME B1.20.1, with female thread.
 - b. NPS 2-1/2 and Larger: ASME B16.5, flanged.
- G. Specialties and Accessories: Include tappings in tank and the following:
 - 1. Pressure gage.
 - 2. Thermometer.
- H. Horizontal Tank Supports: Factory-fabricated steel saddles, welded to tank before testing and labeling.
- I. Vertical Tank Supports: Factory-fabricated steel legs or steel skirt, welded to tank before testing and labeling.
- J. Exterior Coating: Manufacturer's standard enamel paint.
- K. Insulation: Factory-installed fiberglass or polyurethane foam; surrounding entire tank except connections and other openings; suitable for tank operating temperature; and complying with ASHRAE/IESNA 90.1.
- L. Jacket: Steel, with manufacturer's standard finish unless otherwise indicated.

PART 3 - EXECUTION

3.1 VALVE APPLICATIONS

- A. Install shut off-duty valves at each branch connection to supply mains and at supply connection to each piece of equipment.
- B. Install calibrated-orifice, balancing valves at each branch connection to return main.
- C. Install calibrated-orifice, balancing valves in the return pipe of each heating or cooling terminal.
- D. Install check valves at each pump discharge and elsewhere as required to control flow direction.
- E. Install safety valves at hot-water generators and elsewhere as required by ASME Boiler and Pressure Vessel Code. Install drip-pan elbow on safety-valve outlet and pipe without valves to the outdoors; pipe drain to nearest floor drain or as indicated on Drawings. Comply with ASME Boiler and Pressure Vessel Code: Section VIII, Division 1, for installation requirements.
- F. Install pressure-reducing valves at makeup-water connection to regulate system fill pressure.

3.2 HYDRONIC SPECIALTIES INSTALLATION

- A. Install manual air vents at high points in piping, at heat-transfer coils, and elsewhere as required for system air venting.
- B. Automatic air vents may cause damage to ceilings and other finished surfaces. Air vents aid in system filling. Air removal after initial startup is accomplished by air separator or boiler dip tube. Manual air vents may be a better solution.
- C. Install automatic air vents at high points of system piping in mechanical equipment rooms only. Install manual vents at heat-transfer coils and elsewhere as required for air venting.
- D. Install piping from boiler air outlet, air separator, or air purger to expansion tank with a 2 percent upward slope toward tank.
- E. Install in-line air separators in pump suction. Install drain valve on air separators NPS 2 and larger.
- F. Install tangential air separator in pump suction. Install blowdown piping with full-port ball valve; extend full size to nearest floor drain.
- G. Install expansion tanks above the air separator. Install tank fitting in tank bottom and charge tank. Use manual vent for initial fill to establish proper water level in tank.
 - 1. Install tank fittings that are shipped loose.
 - 2. Support tank from floor or structure above with sufficient strength to carry weight of tank, piping connections, fittings, plus tank full of water. Do not overload building components and structural members.
- H. Install expansion tanks on the floor. Vent and purge air from hydronic system, and ensure that tank is properly charged with air to suit system Project requirements.
- I. Install buffer tanks on the floor per manufacturer's instructions.

END OF SECTION 23 2116

THIS PAGE LEFT BLANK INTENTIONALLY

SECTION 23 3001
COMMON DUCT REQUIREMENTS

PART 1 - GENERAL

1.1 SUMMARY

- A. Includes But Not Limited To:
 - 1. General procedures and requirements for ductwork.
 - 2. Repair leaks in ductwork, as identified by smoke test, at no additional cost to Owner.
 - 3. Soundproofing procedures for duct penetrations of walls, ceilings, and floors in mechanical equipment rooms.

- B. Related Sections:
 - 1. Division 07: Quality of Acoustic Sealant.
 - 2. Section 23 0500: Common Work Results for HVAC
 - 3. Section 23 0593: Testing Adjusting and Balancing for HVAC.

1.2 SUBMITTALS

- A. Samples: Sealer and gauze proposed for sealing ductwork.

- B. Quality Assurance / Control:
 - 1. Manufacturer's installation manuals providing detailed instructions on assembly, joint sealing, and system pressure testing for leaks.
 - 2. Specification data on sealer and gauze proposed for sealing ductwork.

1.3 QUALITY ASSURANCE

- A. Requirements: Construction details not specifically called out in Contract Documents shall conform to applicable requirements of SMACNA HVAC Duct Construction Standards.

- B. Pre-Installation Conference: Schedule conference immediately before installation of ductwork.

PART 2 - PRODUCTS

2.1 Finishes, Where Applicable: Colors as selected by Architect.

2.2 Duct Hangers:

- A. One inch by 18 ga galvanized steel straps or steel rods as shown on Drawings, and spaced not more than 96 inches apart. Do not use wire hangers.
 - 1. Attaching screws at trusses shall be 2 inch No. 10 round head wood screws. Nails not allowed.

2. Attach threaded rod to steel joist with Grinnell Steel washer plate Fig. 60 - ph-1. Double nut connection.

2.3 Penetration Soundproofing Materials:

- A. Insulation for Packing: Fiberglass.
- B. Calking: Polysulphide.
- C. Escutcheon Frame: 22 ga galvanized iron 2 inches wide.

PART 3 - EXECUTION

3.1 INSTALLATION

- A. During installation, protect open ends of ducts by covering with plastic sheet tied in place to prevent entrance of debris and dirt.
- B. Make necessary allowances and provisions in installation of sheet metal ducts for structural conditions of building. Revisions in layout and configuration may be allowed, with prior written approval of Architect. Maintain required airflows in suggesting revisions.
- C. Hangers And Supports:
 1. Install upper ends of hanger securely to floor or roof construction above by method shown on Drawings.
 2. Attach strap hangers to ducts with cadmium-plated screws. Use of pop rivets or other means will not be accepted.
 3. Where hangers are secured to forms before concrete slabs are poured, cut off flush all nails, strap ends, and other projections after forms are removed.
 4. Secure vertical ducts passing through floors by extending bracing angles to rest firmly on floors without loose blocking or shimming. Support vertical ducts, which do not pass through floors, by using bands bolted to walls, columns, etc. Size, spacing, and method of attachment to vertical ducts shall be same as specified for hanger bands on horizontal ducts.
- D. Penetration Soundproofing
 1. Pack space between ducts and structure full of fiberglass insulation of sufficient thickness to be wedged tight, allowing space for application of calking.
 2. Provide calking at least 2 inches thick between duct and structure on both ends of opening through structure.
 3. Provide metal escutcheon on Equipment Room side. Secure escutcheon to wall.

3.2 CLEANING

- A. Clean interior of duct systems before final completion.

3.3 CROSS OVER LADDER

- A. All ductwork and piping at walking level that must be crossed for equipment maintenance and service shall have a cross-over ladder.

END OF SECTION 23 3001

SECTION 23 3113

METAL DUCTS

PART 1 - GENERAL

1.1 RELATED DOCUMENTS

- A. Drawings and general provisions of the Contract, including General and Supplementary Conditions and Division 01 Specification Sections, apply to this Section.

1.2 SUMMARY

- A. Section Includes:

1. Single-wall rectangular ducts and fittings.
2. Double-wall rectangular ducts and fittings.
3. Single-wall round and flat-oval ducts and fittings.
4. Double-wall round and flat-oval ducts and fittings.
5. Exhaust Air Stacks
6. Guy wires and connectors.
7. Sheet metal materials.
8. Duct liner.
9. Sealants and gaskets.
10. Hangers and supports.

- B. Related Sections:

1. Section 230593 "Testing, Adjusting, and Balancing for HVAC" for testing, adjusting, and balancing requirements for metal ducts.
2. Section 233119 "HVAC Casings" for factory- and field-fabricated casings for mechanical equipment.
3. Section 233300 "Air Duct Accessories" for dampers, sound-control devices, duct-mounting access doors and panels, turning vanes, and flexible ducts.
4. Section 230713 "Duct Insulation" for duct insulation and fire wrap.

- C. Stacks from the exhaust systems are to be designed per SMACNA guidelines. Use the "Guide for steel stack design and Construction" the latest edition. The outside of the stacks are to be painted with Pota-Pox. 80 series 141 material. Color is to be selected by the architect. Provide guy wires and angle supports. Construction shall be a minimum of 10 gauge and shall be painted on the inside of the stack and on the exterior where the stack is exterior to the building.

1.3 PERFORMANCE REQUIREMENTS

- A. Delegated Duct Design: Duct construction, including sheet metal thicknesses, seam and joint construction, reinforcements, and hangers and supports, shall comply with SMACNA's "HVAC Duct Construction Standards - Metal and Flexible" and performance requirements and design criteria indicated in "Duct Schedule" Article.
- B. Seismic Performance: Duct hangers and supports shall withstand the effects of earthquake motions determined according to SEI/ASCE 7 and with the requirements specified in Section 230548 "Vibration and Seismic Controls for HVAC."

1. For equipment with a seismic importance factor of 1.0 the term "withstand" means "the unit will remain in place without separation of any parts from the device when subjected to the seismic forces specified."
 2. For equipment with a seismic importance factor of 1.5 the term "withstand" means "the unit will remain in place without separation of any parts from the device when subjected to the seismic forces specified and the unit will be fully operational after the seismic event."
- C. Structural Performance: Duct hangers and supports shall withstand the effects of gravity loads and stresses within limits and under conditions described in SMACNA's "HVAC Duct Construction Standards - Metal and Flexible"
- D. Airstream Surfaces: Surfaces in contact with the airstream shall comply with requirements in ASHRAE 62.1.

1.4 ACTION SUBMITTALS

- A. Product Data: For each type of the following products:
1. Liners and adhesives.
 2. Sealants and gaskets.
 3. Seismic-restraint devices.
- B. LEED Submittals:
1. Product Data for Prerequisite IEQ 1: Documentation indicating that duct systems comply with ASHRAE 62.1, Section 5 - "Systems and Equipment."
 2. Product Data for Prerequisite EA 2: Documentation indicating that duct systems comply with ASHRAE/IESNA 90.1, Section 6.4.4 - "HVAC System Construction and Insulation."
 3. Leakage Test Report for Prerequisite EA 2: Documentation of work performed for compliance with ASHRAE/IESNA 90.1, Section 6.4.4.2.2 - "Duct Leakage Tests."
 4. Duct-Cleaning Test Report for Prerequisite IEQ 1: Documentation of work performed for compliance with ASHRAE 62.1, Section 7.2.4 - "Ventilation System Start-up."
 5. Laboratory Test Reports for Credit IEQ 4: For adhesives and sealants, documentation indicating that products comply with the testing and product requirements of the California Department of Health Services' "Standard Practice for the Testing of Volatile Organic Emissions from Various Sources Using Small-Scale Environmental Chambers."
 6. Product Data for Credit IEQ 4.1: For adhesives and sealants, documentation including printed statement of VOC content.
- C. Shop Drawings:
1. Fabrication, assembly, and installation, including plans, elevations, sections, components, and attachments to other work.
 2. Factory- and shop-fabricated ducts and fittings.
 3. Duct layout indicating sizes, configuration, liner material, and static-pressure classes.
 4. Elevation of top of ducts.
 5. Dimensions of main duct runs from building grid lines.
 6. Fittings.
 7. Reinforcement and spacing.
 8. Seam and joint construction.
 9. Penetrations through fire-rated and other partitions.
 10. Equipment installation based on equipment being used on Project.
 11. Locations for duct accessories, including dampers, turning vanes, and access doors and panels.
 12. Hangers and supports, including methods for duct and building attachment, seismic restraints, and vibration isolation.

13. Duct fabrication shall not begin until shop drawings have been submitted and reviewed by the mechanical engineer.

D. Delegated-Design Submittal:

1. Sheet metal thicknesses.
2. Joint and seam construction and sealing.
3. Reinforcement details and spacing.
4. Materials, fabrication, assembly, and spacing of hangers and supports.
5. Design Calculations: Calculations for selecting hangers and supports.

1.5 INFORMATIONAL SUBMITTALS

A. Coordination Drawings: Plans, drawn to scale, on which the following items are shown and coordinated with each other, using input from installers of the items involved:

1. Duct installation in congested spaces, indicating coordination with general construction, building components, and other building services. Indicate proposed changes to duct layout.
2. Suspended ceiling components.
3. Structural members to which duct will be attached.
4. Size and location of initial access modules for acoustical tile.
5. Penetrations of smoke barriers and fire-rated construction.
6. Items penetrating finished ceiling including, but not limited to the following:
 - a. Lighting fixtures.
 - b. Air outlets and inlets.
 - c. Speakers.
 - d. Sprinklers.
 - e. Access panels.
 - f. Perimeter moldings.

B. Field quality-control reports.

1.6 QUALITY ASSURANCE

A. Welding Qualifications: Qualify procedures and personnel according to AWS D1.1/D1.1M, "Structural Welding Code - Steel," for hangers and supports. AWS D9.1M/D9.1, "Sheet Metal Welding Code," for duct joint and seam welding.

B. Welding Qualifications: Qualify procedures and personnel according to the following:

1. AWS D1.1/D1.1M, "Structural Welding Code - Steel," for hangers and supports.
2. AWS D1.2/D1.2M, "Structural Welding Code - Aluminum," for aluminum supports.
3. AWS D9.1M/D9.1, "Sheet Metal Welding Code," for duct joint and seam welding.

C. ASHRAE Compliance: Applicable requirements in ASHRAE 62.1, Section 5 - "Systems and Equipment" and Section 7 - "Construction and System Start-up."

D. ASHRAE/IESNA Compliance: Applicable requirements in ASHRAE/IESNA 90.1, Section 6.4.4 - "HVAC System Construction and Insulation."

PART 2 - PRODUCTS

2.1 SINGLE-WALL RECTANGULAR DUCTS AND FITTINGS

- A. General Fabrication Requirements: Comply with SMACNA's "HVAC Duct Construction Standards - Metal and Flexible" based on indicated static-pressure class unless otherwise indicated.
- B. Transverse Joints: Select joint types and fabricate according to SMACNA's "HVAC Duct Construction Standards - Metal and Flexible," Figure 2-1, "Rectangular Duct/Transverse Joints," for static-pressure class, applicable sealing requirements, materials involved, duct-support intervals, and other provisions in SMACNA's "HVAC Duct Construction Standards - Metal and Flexible."
- C. Longitudinal Seams: Select seam types and fabricate according to SMACNA's "HVAC Duct Construction Standards - Metal and Flexible," Figure 2-2, "Rectangular Duct/Longitudinal Seams," for static-pressure class, applicable sealing requirements, materials involved, duct-support intervals, and other provisions in SMACNA's "HVAC Duct Construction Standards - Metal and Flexible."
- D. Duct dimensions shown on drawings are inside clear dimensions.
- E. Elbows, Transitions, Offsets, Branch Connections, and Other Duct Construction: Select types and fabricate according to SMACNA's "HVAC Duct Construction Standards - Metal and Flexible," Chapter 4, "Fittings and Other Construction," for static-pressure class, applicable sealing requirements, materials involved, duct-support intervals, and other provisions in SMACNA's "HVAC Duct Construction Standards - Metal and Flexible."

2.2 DOUBLE-WALL RECTANGULAR DUCTS AND FITTINGS

- A. Rectangular Ducts: Fabricate ducts with indicated dimensions for the inner duct.
- B. Duct dimensions shown on drawings are inside clear dimensions.
- C. Outer Duct: Comply with SMACNA's "HVAC Duct Construction Standards - Metal and Flexible" based on indicated static-pressure class unless otherwise indicated.
- D. Transverse Joints: Select joint types and fabricate according to SMACNA's "HVAC Duct Construction Standards - Metal and Flexible," Figure 2-1, "Rectangular Duct/Transverse Joints," for static-pressure class, applicable sealing requirements, materials involved, duct-support intervals, and other provisions in SMACNA's "HVAC Duct Construction Standards - Metal and Flexible."
- E. Longitudinal Seams: Select seam types and fabricate according to SMACNA's "HVAC Duct Construction Standards - Metal and Flexible," Figure 2-2, "Rectangular Duct/Longitudinal Seams," for static-pressure class, applicable sealing requirements, materials involved, duct-support intervals, and other provisions in SMACNA's "HVAC Duct Construction Standards - Metal and Flexible."
- F. Interstitial Insulation: Fibrous-glass liner complying with ASTM C 1071, NFPA 90A, or NFPA 90B; and with NAIMA AH124, "Fibrous Glass Duct Liner Standard."
 - 1. Maximum Thermal Conductivity: 0.27 Btu x in./h x sq. ft. x deg Fat 75 deg F mean temperature.
 - 2. Install spacers that position the inner duct at uniform distance from outer duct without compressing insulation.
 - 3. Coat insulation with antimicrobial coating.
 - 4. Cover insulation with polyester film complying with UL 181, Class 1.

- G. Interstitial Insulation: Flexible elastomeric duct liner complying with ASTM C 534, Type II for sheet materials, and with NFPA 90A or NFPA 90B.
 - 1. Maximum Thermal Conductivity: $0.25 \text{ Btu} \times \text{in./h} \times \text{sq. ft.} \times \text{deg F}$ at 75 deg F mean temperature.
- H. Inner Duct: Minimum 0.028-inch solid sheet steel.
- I. Formed-on Transverse Joints (Flanges): Select joint types and fabricate according to SMACNA's "HVAC Duct Construction Standards - Metal and Flexible," Figure 2-1, "Rectangular Duct/Transverse Joints," for static-pressure class, applicable sealing requirements, materials involved, duct-support intervals, and other provisions in SMACNA's "HVAC Duct Construction Standards - Metal and Flexible."
- J. Longitudinal Seams: Select seam types and fabricate according to SMACNA's "HVAC Duct Construction Standards - Metal and Flexible," Figure 2-2, "Rectangular Duct/Longitudinal Seams," for static-pressure class, applicable sealing requirements, materials involved, duct-support intervals, and other provisions in SMACNA's "HVAC Duct Construction Standards - Metal and Flexible."

2.3 SINGLE-WALL ROUND AND FLAT-OVAL DUCTS AND FITTINGS

- A. General Fabrication Requirements: Comply with SMACNA's "HVAC Duct Construction Standards - Metal and Flexible," Chapter 3, "Round, Oval, and Flexible Duct," based on indicated static-pressure class unless otherwise indicated.
- B. Duct dimensions shown on drawings are inside clear dimensions.
- C. Flat-Oval Ducts: Indicated dimensions are the duct width (major dimension) and diameter of the round sides connecting the flat portions of the duct (minor dimension).
- D. Transverse Joints: Select joint types and fabricate according to SMACNA's "HVAC Duct Construction Standards - Metal and Flexible," Figure 3-1, "Round Duct Transverse Joints," for static-pressure class, applicable sealing requirements, materials involved, duct-support intervals, and other provisions in SMACNA's "HVAC Duct Construction Standards - Metal and Flexible."
 - 1. Transverse Joints in Ducts Larger Than 60 Inches in Diameter: Flanged.
- E. Longitudinal Seams: Not allowed.
- F. Tees and Laterals: Select types and fabricate according to SMACNA's "HVAC Duct Construction Standards - Metal and Flexible," Figure 3-5, "90 Degree Tees and Laterals," and Figure 3-6, "Conical Tees," for static-pressure class, applicable sealing requirements, materials involved, duct-support intervals, and other provisions in SMACNA's "HVAC Duct Construction Standards - Metal and Flexible."

2.4 DOUBLE-WALL ROUND AND FLAT-OVAL DUCTS AND FITTINGS

- A. Flat-Oval Ducts: Indicated dimensions are the duct width (major dimension) and diameter of the round sides connecting the flat portions of the duct (minor dimension) of the inner duct.
- B. Duct dimensions shown on drawings are inside clear dimensions.
- C. Outer Duct: Comply with SMACNA's "HVAC Duct Construction Standards - Metal and Flexible," Chapter 3, "Round, Oval, and Flexible Duct," based on static-pressure class unless otherwise indicated.

1. Transverse Joints: Select joint types and fabricate according to SMACNA's "HVAC Duct Construction Standards - Metal and Flexible," Figure 3-1, "Round Duct Transverse Joints," for static-pressure class, applicable sealing requirements, materials involved, duct-support intervals, and other provisions in SMACNA's "HVAC Duct Construction Standards - Metal and Flexible."
 - a. Transverse Joints in Ducts Larger Than 60 Inches in Diameter: Flanged.
 2. Longitudinal Seams: Not allowed.
 3. Tees and Laterals: Select types and fabricate according to SMACNA's "HVAC Duct Construction Standards - Metal and Flexible," Figure 3-5, "90 Degree Tees and Laterals," and Figure 3-6, "Conical Tees," for static-pressure class, applicable sealing requirements, materials involved, duct-support intervals, and other provisions in SMACNA's "HVAC Duct Construction Standards - Metal and Flexible."
- D. Inner Duct: Minimum 0.028-inch solid sheet steel.
1. Perforated inner ducts exposed to air movement shall not be used in supply air ducts upstream of the following rooms: Operating rooms, trauma rooms, LDR rooms, NICU nurseries, ICU nurseries, positive pressure isolation rooms, cath labs, bone marrow, triage rooms, angiogram rooms, fluoroscopy rooms, linear accelerators, decontamination areas and any invasive procedure rooms where the duct insulation could be a source of contamination.
 2. Inner duct shall be solid sheet steel a minimum of 10 feet downstream of humidifiers and/or air washers.
- E. Interstitial Insulation: Fibrous-glass liner complying with ASTM C 1071, NFPA 90A, or NFPA 90B; and with NAIMA AH124, "Fibrous Glass Duct Liner Standard."
1. Maximum Thermal Conductivity: 0.27 Btu x in./h x sq. ft. x deg F at 75 deg F mean temperature.
 2. Install spacers that position the inner duct at uniform distance from outer duct without compressing insulation.
 3. Coat insulation with antimicrobial coating.
 4. Cover insulation with polyester film complying with UL 181, Class 1.
- F. Interstitial Insulation: Flexible elastomeric duct liner complying with ASTM C 534, Type II for sheet materials, and with NFPA 90A or NFPA 90B.
1. Maximum Thermal Conductivity: 0.25 Btu x in./h x sq. ft. x deg Fat 75 deg F mean temperature.

2.5 EXHAUST AIR STACKS

- A. General Fabrication Requirements: Comply with SMACNA's "HVAC Duct Construction Standards - Metal and Flexible," Chapter 3, "Round, Oval, and Flexible Duct," based on indicated static-pressure class unless otherwise indicated.
- B. Transverse Joints: Select joint types and fabricate according to SMACNA's "HVAC Duct Construction Standards - Metal and Flexible," Figure 3-1, "Round Duct Transverse Joints," for static-pressure class, applicable sealing requirements, materials involved, duct-support intervals, and other provisions in SMACNA's "HVAC Duct Construction Standards - Metal and Flexible."
 1. Transverse Joints in Ducts Larger Than 60 Inches in Diameter: Flanged.
- C. Longitudinal Seams: Not allowed.

- D. Tees and Laterals: Select types and fabricate according to SMACNA's "HVAC Duct Construction Standards - Metal and Flexible," Figure 3-5, "90 Degree Tees and Laterals," and Figure 3-6, "Conical Tees," for static-pressure class, applicable sealing requirements, materials involved, duct-support intervals, and other provisions in SMACNA's "HVAC Duct Construction Standards - Metal and Flexible."
- E. Design Wind Loads: 150 mph.
- F. Design for seismic conditions at Project site.
- G. Accessories: Terminations, adjustable roof flashings, storm collars, support assemblies, thimbles, firestop spacers, and fasteners; fabricated from similar materials and designs as duct straight sections.
 - 1. Termination: Antibackdraft damper.
- H. Drain: Provide drain section incorporated into base of stack with trap. Seal depth design to prevent seal blowout at highest estimated static pressure.
- I. Guying and Bracing Materials
 - 1. Cable: Three minimum galvanized or stainless steel, stranded wires of the following thickness: [Four] <Insert number> [stainless steel]
 - a. Minimum Size: 1/4 inch in diameter.
 - b. For ID Sizes 4 to 15 Inches: 5/16 inch.
 - c. For ID Sizes 18 to 24 Inches: 3/8 inch.
 - d. For ID Sizes 27 to 30 Inches: 7/16 inch.
 - e. For ID Sizes 33 to 36 Inches: 1/2 inch.
 - f. For ID Sizes 39 to 48 Inches: 9/16 inch.
 - g. For ID Sizes 51 to 60 Inches: 5/8 inch.
 - 2. Cable Hardware: Provide duct angle ring, turnbuckles, cable loop thimbles, cable clamps and all hardware necessary to brace stack.
 - 3. Pipe: Two galvanized steel, NPS 1-1/4. [Three].
 - 4. Angle Iron: Two galvanized steel, 2 by 2 by 0.25 inch. [Three].

2.6 SHEET METAL MATERIALS

- A. General Material Requirements: Comply with SMACNA's "HVAC Duct Construction Standards - Metal and Flexible" for acceptable materials, material thicknesses, and duct construction methods unless otherwise indicated. Sheet metal materials shall be free of pitting, seam marks, roller marks, stains, discolorations, and other imperfections.
- B. Galvanized Sheet Steel: Comply with ASTM A 653.
 - 1. Galvanized Coating Designation: G90.
 - 2. Finishes for Surfaces Exposed to View: Mill phosphatized.
- C. Carbon-Steel Sheets: Comply with ASTM A 1008, with oiled, matte finish for exposed ducts.
- D. Reinforcement Shapes and Plates: ASTM A 36, steel plates, shapes, and bars; black and galvanized.
 - 1. Where black- and galvanized-steel shapes and plates are used to reinforce aluminum ducts, isolate the different metals with butyl rubber, neoprene, or EPDM gasket materials.

- E. Tie Rods: Galvanized steel, 1/4-inch minimum diameter for lengths 36 inches or less; 3/8-inch minimum diameter for lengths longer than 36 inches.

2.7 DUCT LINER

- A. Per ASHRAE Standard 170 section 6.9 duct liner shall not be installed in ductwork downstream of filter bank #2 for this project.

2.8 SEALANT AND GASKETS

- A. General Sealant and Gasket Requirements: Surface-burning characteristics for sealants and gaskets shall be a maximum flame-spread index of 25 and a maximum smoke-developed index of 50 when tested according to UL 723; certified by an NRTL.

- B. Two-Part Tape Sealing System:

1. Tape: Woven cotton fiber impregnated with mineral gypsum and modified acrylic/silicone activator to react exothermically with tape to form hard, durable, airtight seal.
2. Tape Width: 4 inches.
3. Sealant: Modified styrene acrylic.
4. Water resistant.
5. Mold and mildew resistant.
6. Maximum Static-Pressure Class: 10-inch wg, positive and negative.
7. Service: Indoor and outdoor.
8. Service Temperature: Minus 40 to plus 200 deg F.
9. Substrate: Compatible with galvanized sheet steel (both PVC coated and bare), stainless steel, or aluminum.
10. For indoor applications, sealant shall have a VOC content of 250 g/L or less when calculated according to 40 CFR 59, Subpart D (EPA Method 24).
11. Sealant shall comply with the testing and product requirements of the California Department of Health Services' "Standard Practice for the Testing of Volatile Organic Emissions from Various Sources Using Small-Scale Environmental Chambers."

- C. Water-Based Joint and Seam Sealant:

1. Application Method: Brush on.
2. Solids Content: Minimum 65 percent.
3. Shore A Hardness: Minimum 20.
4. Water resistant.
5. Mold and mildew resistant.
6. VOC: Maximum 75 g/L (less water).
7. Maximum Static-Pressure Class: 10-inch wg, positive and negative.
8. Service: Indoor or outdoor.
9. Substrate: Compatible with galvanized sheet steel, stainless steel, or aluminum sheets.

- D. Solvent-Based Joint and Seam Sealant:

1. Application Method: Brush on.
2. Base: Synthetic rubber resin.
3. Solvent: Toluene and heptane.
4. Solids Content: Minimum 60 percent.
5. Shore A Hardness: Minimum 60.
6. Water resistant.
7. Mold and mildew resistant.
8. For indoor applications, sealant shall have a VOC content of 250 g/L or less when calculated according to 40 CFR 59, Subpart D (EPA Method 24).
9. VOC: Maximum 395 g/L.

10. Sealant shall comply with the testing and product requirements of the California Department of Health Services' "Standard Practice for the Testing of Volatile Organic Emissions from Various Sources Using Small-Scale Environmental Chambers."
 11. Maximum Static-Pressure Class: 10-inch wg, positive or negative.
 12. Service: Indoor or outdoor.
 13. Substrate: Compatible with galvanized sheet steel (both PVC coated and bare), stainless steel, or aluminum sheets.
- E. Flanged Joint Sealant: Comply with ASTM C 920.
1. General: Single-component, acid-curing, silicone, elastomeric.
 2. Type: S.
 3. Grade: NS.
 4. Class: 25.
 5. Use: O.
 6. For indoor applications, sealant shall have a VOC content of 250 g/L or less when calculated according to 40 CFR 59, Subpart D (EPA Method 24).
 7. Sealant shall comply with the testing and product requirements of the California Department of Health Services' "Standard Practice for the Testing of Volatile Organic Emissions from Various Sources Using Small-Scale Environmental Chambers."
- F. Flange Gaskets: Butyl rubber, neoprene, or EPDM polymer with polyisobutylene plasticizer.
- G. Round Duct Joint O-Ring Seals:
1. Seal shall provide maximum leakage class of 3 cfm/100 sq. ft. at 1-inch wg and shall be rated for 10-inch wg static-pressure class, positive or negative.
 2. EPDM O-ring to seal in concave bead in coupling or fitting spigot.
 3. Double-lipped, EPDM O-ring seal, mechanically fastened to factory-fabricated couplings and fitting spigots.

2.9 HANGERS AND SUPPORTS

- A. Hanger Rods for Noncorrosive Environments: Cadmium-plated steel rods and nuts.
- B. Hanger Rods for Corrosive Environments: Electrogalvanized, all-thread rods or galvanized rods with threads painted with zinc-chromate primer after installation.
- C. Strap and Rod Sizes: Comply with SMACNA's "HVAC Duct Construction Standards - Metal and Flexible," Table 5-1, "Rectangular Duct Hangers Minimum Size," and Table 5-2, "Minimum Hanger Sizes for Round Duct."
- D. Steel Cables for Galvanized-Steel Ducts: Galvanized steel complying with ASTM A 603.
- E. Steel Cables for Stainless-Steel Ducts: Stainless steel complying with ASTM A 492.
- F. Steel Cable End Connections: Cadmium-plated steel assemblies with brackets, swivel, and bolts designed for duct hanger service; with an automatic-locking and clamping device.
- G. Duct Attachments: Sheet metal screws, blind rivets, or self-tapping metal screws; compatible with duct materials.
- H. Trapeze and Riser Supports:
1. Supports for Galvanized-Steel Ducts: Galvanized-steel shapes and plates.
 2. Supports for Stainless-Steel Ducts: Stainless-steel shapes and plates.
 3. Supports for Aluminum Ducts: Aluminum or galvanized steel coated with zinc chromate.

PART 3 - EXECUTION

3.1 DUCT INSTALLATION

- A. Drawing plans, schematics, and diagrams indicate general location and arrangement of duct system. Indicated duct locations, configurations, and arrangements were used to size ducts and calculate friction loss for air-handling equipment sizing and for other design considerations. Install duct systems as indicated unless deviations to layout are approved on Shop Drawings and Coordination Drawings.
- B. Install ducts according to SMACNA's "HVAC Duct Construction Standards - Metal and Flexible" unless otherwise indicated.
- C. Install round and flat-oval ducts in maximum practical lengths.
- D. Install ducts with fewest possible joints.
- E. Install factory- or shop-fabricated fittings for changes in direction, size, and shape and for branch connections.
- F. Unless otherwise indicated, install ducts vertically and horizontally, and parallel and perpendicular to building lines.
- G. Install ducts close to walls, overhead construction, columns, and other structural and permanent enclosure elements of building.
- H. Install ducts with a clearance of 2 inch, plus allowance for insulation thickness.
- I. Route ducts to avoid passing through transformer vaults and electrical equipment rooms and enclosures.
- J. Where ducts pass through non-fire-rated interior partitions and exterior walls and are exposed to view, cover the opening between the partition and duct or duct insulation with sheet metal flanges of same metal thickness as the duct. Overlap openings on four sides by at least 1-1/2 inches.
- K. Where ducts pass through fire-rated interior partitions and exterior walls, install fire dampers. Comply with requirements in Section 233300 "Air Duct Accessories" for fire and smoke dampers.
- L. Protect duct interiors from moisture, construction debris and dust, and other foreign materials. Comply with SMACNA's "IAQ Guidelines for Occupied Buildings Under Construction," Appendix G, "Duct Cleanliness for New Construction Guidelines".
- M. Where ducts pass through sound-rated walls, fill the opening between the partition and duct with insulation and seal the opening.

3.2 INSTALLATION OF EXPOSED DUCTWORK

- A. Protect ducts exposed in finished spaces from being dented, scratched, or damaged.
- B. Trim duct sealants flush with metal. Create a smooth and uniform exposed bead. Do not use two-part tape sealing system.
- C. Grind welds to provide smooth surface free of burrs, sharp edges, and weld splatter. When welding stainless steel with a No. 3 or 4 finish, grind the welds flush, polish the exposed welds, and treat the welds to remove discoloration caused by welding.

- D. Maintain consistency, symmetry, and uniformity in the arrangement and fabrication of fittings, hangers and supports, duct accessories, and air outlets.
- E. Repair or replace damaged sections and finished work that does not comply with these requirements.

3.3 ADDITIONAL INSTALLATION REQUIREMENTS FOR COMMERCIAL KITCHEN HOOD EXHAUST DUCT

- A. Install commercial kitchen hood exhaust ducts without dips and traps that may hold grease, and sloped a minimum of 2 percent to drain grease back to the hood.
- B. Install fire-rated access panel assemblies at each change in direction and at maximum intervals of 12 feet in horizontal ducts, and at every floor for vertical ducts, or as indicated on Drawings. Locate access panel on top or sides of duct a minimum of 1-1/2 inches from bottom of duct. [20 feet]
- C. Do not penetrate fire-rated assemblies except as allowed by applicable building codes and authorities having jurisdiction.
- D. Perform a light test of grease ductwork per 2012 International Mechanical Code paragraph 506.3.2.5. prior to concealment by insulation or covered by shaft.
 - 1. Perform light test in the presence of local Inspector/Engineer.
 - 2. Document whether test passed or failed.
 - 3. Repair any joints or duct welds that fail light test to the point the ductwork passes the light test.
- E. Install grease duct with minimum clearance to combustibles as required by IBC and local codes. Installations that do not meet the minimum required clearances shall be fire wrapped as specified in Section 230713 "Duct Insulation".
- F. Provide approved fire-wrap insulation that meets ASTM C 656.

3.4 DUCT SEALING

- A. Seal ducts for duct static-pressure, seal classes, and leakage classes specified in "Duct Schedule" Article according to SMACNA's "HVAC Duct Construction Standards - Metal and Flexible."
- B. Seal ducts to the following seal classes according to SMACNA's "HVAC Duct Construction Standards - Metal and Flexible":
 - 1. Comply with SMACNA's "HVAC Duct Construction Standards - Metal and Flexible."
 - 2. Outdoor, Supply-Air Ducts: Seal Class A.
 - 3. Outdoor, Exhaust Ducts: Seal Class A.
 - 4. Outdoor, Return-Air Ducts: Seal Class A.
 - 5. Unconditioned Space, Supply-Air Ducts in Pressure Classes 2-Inch wg and Lower: Seal Class A.
 - 6. Unconditioned Space, Supply-Air Ducts in Pressure Classes Higher Than 2-Inch wg: Seal Class A.
 - 7. Unconditioned Space, Exhaust Ducts: Seal Class A.
 - 8. Unconditioned Space, Return-Air Ducts: Seal Class A.

9. Conditioned Space, Supply-Air Ducts in Pressure Classes 2-Inch wg and Lower: Seal Class A.
10. Conditioned Space, Supply-Air Ducts in Pressure Classes Higher Than 2-Inch wg: Seal Class A.
11. Conditioned Space, Exhaust Ducts: Seal Class A.
12. Conditioned Space, Return-Air Ducts: Seal Class A.

3.5 HANGER AND SUPPORT INSTALLATION

- A. Comply with SMACNA's "HVAC Duct Construction Standards - Metal and Flexible," Chapter 5, "Hangers and Supports."
- B. Building Attachments: Concrete inserts, powder-actuated fasteners, or structural-steel fasteners appropriate for construction materials to which hangers are being attached.
 1. Where practical, install concrete inserts before placing concrete.
 2. Install powder-actuated concrete fasteners after concrete is placed and completely cured.
 3. Use powder-actuated concrete fasteners for standard-weight aggregate concretes or for slabs more than 4 inchesthick.
 4. Do not use powder-actuated concrete fasteners for lightweight-aggregate concretes or for slabs less than 4 inchesthick.
 5. Do not use powder-actuated concrete fasteners for seismic restraints.
- C. Hanger Spacing: Comply with SMACNA's "HVAC Duct Construction Standards - Metal and Flexible," Table 5-1, "Rectangular Duct Hangers Minimum Size," and Table 5-2, "Minimum Hanger Sizes for Round Duct," for maximum hanger spacing; install hangers and supports within 24 inches of each elbow and within 48 inches of each branch intersection.
- D. Hangers Exposed to View: Threaded rod and angle or channel supports.
- E. Support vertical ducts with steel angles or channel secured to the sides of the duct with welds, bolts, sheet metal screws, or blind rivets; support at each floor and at a maximum intervals of 16 feet.
- F. Install upper attachments to structures. Select and size upper attachments with pull-out, tension, and shear capacities appropriate for supported loads and building materials where used.

3.6 SEISMIC-RESTRAINT-DEVICE INSTALLATION

- A. Install ducts with hangers and braces designed to support the duct and to restrain against seismic forces required by applicable building codes. Comply with the requirements specified in Section 230548 "Vibration and Seismic Controls for HVAC."
 1. Comply with ASCE/SEI 7.

3.7 CONNECTIONS

- A. Make connections to equipment with flexible connectors complying with Section 233300 "Air Duct Accessories."
- B. Comply with SMACNA's "HVAC Duct Construction Standards - Metal and Flexible" for branch, outlet and inlet, and terminal unit connections.

3.8 PAINTING

- A. Paint interior of metal ducts that are visible through registers and grilles and that do not have duct liner. Apply one coat of flat, black, latex paint over a compatible galvanized-steel primer. Paint materials and application requirements are specified in Section 099113 "Exterior Painting" and Section 099123 "Interior Painting."

3.9 FIELD QUALITY CONTROL

- A. Perform tests and inspections.
- B. Leakage Tests:
 - 1. Comply with SMACNA's "HVAC Air Duct Leakage Test Manual." Submit a test report for each test.
 - 2. Test the following systems:
 - a. Ducts with a Pressure Class Higher Than 3-Inch wg: Test representative duct sections, selected by Architect from sections installed, totaling no less than 25 percent of total installed duct area for each designated pressure class.
 - b. Supply Ducts with a Pressure Class of 2-Inch wg or Higher: Test representative duct sections, selected by Architect from sections installed, totaling no less than 50 percent of total installed duct area for each designated pressure class.
 - c. Return Ducts with a Pressure Class of 2-Inch wg or Higher: Test representative duct sections, selected by Architect from sections installed, totaling no less than 50 percent of total installed duct area for each designated pressure class.
 - d. Exhaust Ducts with a Pressure Class of 2-Inch wg or Higher: Test representative duct sections, selected by Architect from sections installed, totaling no less than 50 percent of total installed duct area for each designated pressure class.
 - e. Outdoor Air Ducts with a Pressure Class of 2-Inch wg or Higher: Test representative duct sections, selected by Architect from sections installed, totaling no less than 50 percent of total installed duct area for each designated pressure class.
 - 3. Disassemble, reassemble, and seal segments of systems to accommodate leakage testing and for compliance with test requirements.
 - 4. Test for leaks before applying external insulation.
 - 5. Conduct tests at static pressures equal to maximum design pressure of system or section being tested. If static-pressure classes are not indicated, test system at maximum system design pressure. Do not pressurize systems above maximum design operating pressure.
 - 6. Give seven days' advance notice for testing.
- C. Duct System Cleanliness Tests:
 - 1. Visually inspect duct system to ensure that no visible contaminants are present.
 - 2. Test sections of metal duct system, chosen randomly by Owner, for cleanliness according to "Vacuum Test" in NADCA ACR, "Assessment, Cleaning and Restoration of HVAC Systems."
 - a. Acceptable Cleanliness Level: Net weight of debris collected on the filter media shall not exceed 0.75 mg/100 sq. cm.
 - 3. Any liner showing evidence that is has wet at any time shall be removed and replaced with new liner.
 - a. Disinfect affected sheet metal, and pins.
 - b. Install new liner per specifications
 - c. Seal friable edges and seams of repaired liner.

- D. Duct system will be considered defective if it does not pass tests and inspections.
- E. Prepare test and inspection reports.

3.10 DUCT CLEANING

- A. Clean new duct system before testing, adjusting, and balancing.
- B. Use service openings for entry and inspection.
 - 1. Create new openings and install access panels appropriate for duct static-pressure class if required for cleaning access. Provide insulated panels for insulated or lined duct. Patch insulation and liner as recommended by duct liner manufacturer. Comply with Section 233300 "Air Duct Accessories" for access panels and doors.
 - 2. Disconnect and reconnect flexible ducts as needed for cleaning and inspection.
 - 3. Remove and reinstall ceiling to gain access during the cleaning process.
- C. Particulate Collection and Odor Control:
 - 1. When venting vacuuming system inside the building, use HEPA filtration with 99.97 percent collection efficiency for 0.3-micron-size (or larger) particles.
 - 2. When venting vacuuming system to outdoors, use filter to collect debris removed from HVAC system, and locate exhaust downwind and away from air intakes and other points of entry into building.
- D. Clean the following components by removing surface contaminants and deposits:
 - 1. Air outlets and inlets (registers, grilles, and diffusers).
 - 2. Supply, return, and exhaust fans including fan housings, plenums (except ceiling supply and return plenums), scrolls, blades or vanes, shafts, baffles, dampers, and drive assemblies.
 - 3. Air-handling unit internal surfaces and components including mixing box, coil section, air wash systems, spray eliminators, condensate drain pans, humidifiers and dehumidifiers, filters and filter sections, and condensate collectors and drains.
 - 4. Coils and related components.
 - 5. Return-air ducts, dampers, actuators, and turning vanes except in ceiling plenums and mechanical equipment rooms.
 - 6. Supply-air ducts, dampers, actuators, and turning vanes.
 - 7. Dedicated exhaust and ventilation components and makeup air systems.
- E. Mechanical Cleaning Methodology:
 - 1. Clean metal duct systems using mechanical cleaning methods that extract contaminants from within duct systems and remove contaminants from building.
 - 2. Use vacuum-collection devices that are operated continuously during cleaning. Connect vacuum device to downstream end of duct sections so areas being cleaned are under negative pressure.
 - 3. Use mechanical agitation to dislodge debris adhered to interior duct surfaces without damaging integrity of metal ducts, duct liner, or duct accessories.
 - 4. Clean fibrous-glass duct liner with HEPA vacuuming equipment; do not permit duct liner to get wet. Replace fibrous-glass duct liner that is damaged, deteriorated, or delaminated or that has friable material, mold, or fungus growth.
 - 5. Clean coils and coil drain pans according to NADCA 1992. Keep drain pan operational. Rinse coils with clean water to remove latent residues and cleaning materials; comb and straighten fins.
 - 6. Provide drainage and cleanup for wash-down procedures.
 - 7. Antimicrobial Agents and Coatings: Apply EPA-registered antimicrobial agents if fungus is present. Apply antimicrobial agents according to manufacturer's written instructions after removal of surface deposits and debris.

3.11 START UP

- A. Air Balance: Comply with requirements in Section 230593 "Testing, Adjusting, and Balancing for HVAC."

3.12 DUCT SCHEDULE

- A. Fabricate ducts with galvanized sheet steel.
- B. Ductwork running in areas where there are no ceilings or when noted on the drawings shall be doubled wall duct and shall meet the requirements indicated below.
- C. BSL-3 Ducts:
 - 1. Supply and exhaust ducts serving BSL-3 areas :
 - a. Type 304 .05-inch thick stainless-steel sheet.
 - 1) Exposed to View: No. 4 finish.
 - 2) Concealed: No. 2B finish.
 - b. Pressure Class: Positive or negative 6-inch wg.
 - c. Minimum SMACNA Seal Class: Welded seams, joints, and penetrations.
 - d. SMACNA Leakage Class: 2.
 - e. Supply ducts outside of BSL-3 area shall transition to galvanized.
- D. MRI Ducts:
 - 1. All ducts Connected to and serving MRI Areas:
 - a. All ductwork shall be aluminum with non-ferrous hardware and accessories.
 - b. Pressure Class: Positive or negative 6-inch wg.
 - c. Minimum SMACNA Seal Class: Welded seams, joints, and penetrations.
 - d. SMACNA Leakage Class: 2.
- E. Supply Ducts:
 - 1. Ducts Connected to Fan Coil Units, Furnaces, Heat Pumps, and Terminal Units:
 - a. Pressure Class: Positive 2-inch wg.
 - b. Minimum SMACNA Seal Class: A.
 - c. SMACNA Leakage Class for Rectangular: 16.
 - d. SMACNA Leakage Class for Round and Flat Oval: 8.
 - 2. Ducts Connected to Constant-Volume Air-Handling Units:
 - a. Pressure Class: Positive 3-inch wg.
 - b. Minimum SMACNA Seal Class: A.
 - c. SMACNA Leakage Class for Rectangular: 8.
 - d. SMACNA Leakage Class for Round and Flat Oval: 4.
 - 3. Ducts Connected to Variable-Air-Volume Air-Handling Units:
 - a. Pressure Class: Positive 6-inch wg.
 - b. Minimum SMACNA Seal Class: A.
 - c. SMACNA Leakage Class for Rectangular: 4.
 - d. SMACNA Leakage Class for Round and Flat Oval: 2.
 - 4. Ducts Connected to Equipment Not Listed Above:

- a. Pressure Class: Positive 4-inch wg.
- b. Minimum SMACNA Seal Class: A.
- c. SMACNA Leakage Class for Rectangular: 4.
- d. SMACNA Leakage Class for Round and Flat Oval: 2.

F. Return Ducts:

1. Ducts Connected to Fan Coil Units, Furnaces, Heat Pumps, and Terminal Units:
 - a. Pressure Class: Positive or negative 2-inch wg.
 - b. Minimum SMACNA Seal Class: A.
 - c. SMACNA Leakage Class for Rectangular: 16.
 - d. SMACNA Leakage Class for Round and Flat Oval: 8 .
2. Ducts Connected to Air-Handling Units:
 - a. Pressure Class: Positive or negative 2-inch wg.
 - b. Minimum SMACNA Seal Class: A.
 - c. SMACNA Leakage Class for Rectangular: 16.
 - d. SMACNA Leakage Class for Round and Flat Oval: 8.
3. Ducts Connected to Equipment Not Listed Above:
 - a. Pressure Class: Positive or negative 3-inch wg.
 - b. Minimum SMACNA Seal Class: A.
 - c. SMACNA Leakage Class for Rectangular: 8.
 - d. SMACNA Leakage Class for Round and Flat Oval: 4.

G. Exhaust Ducts:

1. Ducts Connected to Fans Exhausting (ASHRAE 62.1, Class 1 and 2) Air:
 - a. Pressure Class: Negative 2-inch wg.
 - b. Minimum SMACNA Seal Class: A.
 - c. SMACNA Leakage Class for Rectangular: 16.
 - d. SMACNA Leakage Class for Round and Flat Oval: 4.
2. Ducts Connected to Air-Handling Units:
 - a. Pressure Class: Positive or negative 3-inch wg.
 - b. Minimum SMACNA Seal Class: A.
 - c. SMACNA Leakage Class for Rectangular: 8.
 - d. SMACNA Leakage Class for Round and Flat Oval: 4.
3. Ducts Connected to Variable-Air-Volume Air-Handling Units:
 - a. Pressure Class: Positive 6-inch wg.
 - b. Minimum SMACNA Seal Class: A.
 - c. SMACNA Leakage Class for Rectangular: 4.
 - d. SMACNA Leakage Class for Round and Flat Oval: 2.
4. Ducts Connected to Type I (Grease) Commercial Kitchen Hoods: Comply with NFPA 96.
 - a. Exposed to View: 18 gauge Type 304, stainless-steel sheet, No. 4 finish.
 - b. Concealed: 16 gauge black steel.
 - c. Pressure Class: Positive or negative 3-inch wg.
 - d. Welded seams and joints.
 - e. Minimum SMACNA Seal Class: Welded seams, joints, and penetrations.

- f. SMACNA Leakage Class: 2.
 - g. A light test shall be performed for grease duct prior to concealing the duct.
5. Ducts Connected to Type II (Heat) Commercial Kitchen Hoods:
- a. Type 304, stainless-steel sheet.
 - b. Exposed to View: No. 4 finish.
 - c. Pressure Class: Positive or negative 3-inch wg.
 - d. Concealed: No. 2D finish.
 - e. Welded seams and joints.
 - f. Minimum SMACNA Seal Class: Welded seams, joints, and penetrations.
 - g. SMACNA Leakage Class: 2.
6. Ducts Connected to Dishwasher and Low Temperature Vapor and Odor Hoods:
- a. Type 304, stainless-steel sheet.
 - b. Exposed to View: No. 4 finish. Pressure Class: Positive or negative 3-inch wg.
 - c. Concealed: No. 2D finish.
 - d. Welded seams and flanged joints with watertight EPDM gaskets.
 - e. Minimum SMACNA Seal Class: Welded seams, joints, and penetrations, flanged joints class A.
 - f. SMACNA Leakage Class: 2.
7. Ducts Connected to Fans Exhausting Laboratory and Process (ASHRAE 62.1, Class 3 and 4) Air:
- a. Type 304, stainless-steel sheet.
 - 1) 0.05-inch thick.
 - 2) Exposed to View: No. 4 finish.
 - 3) Concealed: No. 2B finish.
 - b. Pressure Class: Positive or negative 6-inch wg.
 - c. Minimum SMACNA Seal Class: Welded seams, joints, and penetrations.
 - d. SMACNA Leakage Class: 2.
 - e. Main laboratory exhaust trunks to be galvanized steel with same pressure, seal and leakage class.
8. Ducts Connected to Cage Wash Areas:
- a. Type 316 .05-inch thick stainless-steel sheet.
 - 1) Exposed to View: No. 4 finish.
 - 2) Concealed: No. 2B finish.
 - b. Pressure Class: Positive or negative 6-inch wg.
 - c. Minimum SMACNA Seal Class: Welded seams, joints, and penetrations.
 - d. SMACNA Leakage Class: 2.
9. Ducts Connected to radioactive fume hoods:
- a. Type 316 .05-inch thick stainless-steel sheet.
 - 1) Exposed to View: No. 4 finish.
 - 2) Concealed: No. 2B finish.
 - b. Pressure Class: Positive or negative 6-inch wg.
 - c. Minimum SMACNA Seal Class: A. Flanged and gasketed joints for future disassembly for decontamination.

- d. SMACNA Leakage Class: 2.
10. Ducts Connected to Equipment Not Listed Above:
- a. Pressure Class: Positive or negative 4-inch wg.
 - b. Minimum SMACNA Seal Class: A.
 - c. SMACNA Leakage Class for Rectangular: 4.
 - d. SMACNA Leakage Class for Round and Flat Oval: 2
- H. Outdoor-Air (Not Filtered, Heated, or Cooled) Ducts:
- 1. Ducts Connected to Fan Coil Units, Furnaces, Heat Pumps, and Terminal Units:
 - a. Pressure Class: Positive or negative 2-inch wg.
 - b. Minimum SMACNA Seal Class: A.
 - c. SMACNA Leakage Class for Rectangular: 16.
 - d. SMACNA Leakage Class for Round and Flat Oval: 4.
 - 2. Ducts Connected to Air-Handling Units:
 - a. Pressure Class: Positive or negative 3-inch wg.
 - b. Minimum SMACNA Seal Class: A.
 - c. SMACNA Leakage Class for Rectangular: 8.
 - d. SMACNA Leakage Class for Round and Flat Oval: 4.
 - 3. Ducts Connected to Equipment Not Listed Above:
 - a. Pressure Class: Positive or negative 3-inch wg.
 - b. Minimum SMACNA Seal Class: A.
 - c. SMACNA Leakage Class for Rectangular: 8.
 - d. SMACNA Leakage Class for Round and Flat Oval: 4.
- I. Intermediate Reinforcement:
- 1. Galvanized-Steel Ducts: Galvanized steel.
 - 2. Stainless-Steel Ducts:
 - a. Exposed to Airstream: Match duct material.
 - b. Not Exposed to Airstream: Match duct material.
 - 3. Aluminum Ducts: Aluminum.
- J. Duct Liner Restrictions:
- 1. Duct liner is not allowed in any ductwork on this project per ASHRAE Standard 170 section 6.9.
- K. Double-Wall Duct Interstitial Insulation:
- 1. Supply Air Ducts: 1 inch thick.
 - 2. Return Air Ducts: 1 inch thick.
 - 3. Exhaust Air Ducts: 1 inch thick.
- L. Exterior Ductwork Liner Insulation:
- 1. Supply Air Ducts: 2 inch thick with a minimum R value of 8.0.

2. Return Air Ducts: 2 inch thick with a minimum R value of 8.0.
3. Exhaust Air Ducts: 2 inch thick with a minimum R value of 8.0.

M. Elbow Configuration:

1. Rectangular Duct: Comply with SMACNA's "HVAC Duct Construction Standards - Metal and Flexible," Figure 4-2, "Rectangular Elbows."
 - a. Radius Type RE 1 with minimum 1.5 radius-to-diameter ratio.
 - b. Radius Type RE 3 with minimum 1.0 radius-to-diameter ratio and two vanes.
 - c. Mitered Type RE 2 with vanes complying with SMACNA's "HVAC Duct Construction Standards - Metal and Flexible," Figure 4-3, "Vanes and Vane Runners," and Figure 4-4, "Vane Support in Elbows."
2. Round Duct: Comply with SMACNA's "HVAC Duct Construction Standards - Metal and Flexible," Figure 3-4, "Round Duct Elbows."
 - a. Minimum Radius-to-Diameter Ratio and Elbow Segments: Comply with SMACNA's "HVAC Duct Construction Standards - Metal and Flexible," Table 3-1, "Mitered Elbows." Elbows with less than 90-degree change of direction have proportionately fewer segments.
 - 1) Velocity 1000 fpm or Lower: 1.0 radius-to-diameter ratio and three segments for 90-degree elbow.
 - 2) Velocity 1000 to 1500 fpm: 1.5 radius-to-diameter ratio and four segments for 90-degree elbow.
 - 3) Velocity 1500 fpm or Higher: 1.5 radius-to-diameter ratio and five segments for 90-degree elbow.
 - 4) Radius-to Diameter Ratio: 1.5.
 - b. Round Elbows, 12 Inches and Smaller in Diameter: Stamped or pleated.
 - c. Round Elbows, 14 Inches and Larger in Diameter: Welded.

N. Branch Configuration:

1. Rectangular Duct: Comply with SMACNA's "HVAC Duct Construction Standards - Metal and Flexible," Figure 4-6, "Branch Connection."
 - a. Rectangular Main to Rectangular Branch: 45-degree entry high efficiency take-off.
 - b. Rectangular Main to Round Branch: 45-degree entry high efficiency take-off.
2. Round and Flat Oval:
 - a. Comply with SMACNA's "HVAC Duct Construction Standards - Metal and Flexible," Figure 3-5, "90 Degree Tees and Laterals," and Figure 3-6, "Conical Tees." Saddle taps are permitted in existing duct.
 - b. Velocity 1000 to 1500 fpm: 45-degree entry high efficiency tap.
 - c. Velocity 1500 fpm or Higher: 45-degree lateral.

END OF SECTION 23 3113

THIS PAGE LEFT BLANK INTENTIONALLY

SECTION 23 3300

AIR DUCT ACCESSORIES

PART 1 - GENERAL

1.1 RELATED DOCUMENTS

- A. Drawings and general provisions of the Contract, including General and Supplementary Conditions and Division 01 Specification Sections, apply to this Section.

1.2 SUMMARY

- A. Section Includes:

1. Backdraft dampers.
2. Pressure relief dampers.
3. Barometric relief dampers.
4. Manual volume dampers.
5. Control dampers.
6. Fire dampers.
7. Smoke dampers.
8. Combination fire and smoke dampers.
9. Duct silencers.
10. Turning vanes.
11. Remote damper operators.
12. Duct-mounted access doors.
13. Flexible connectors.
14. Flexible ducts.
15. Duct security bars.
16. Duct accessory hardware.
17. High efficiency take-offs.

- B. Related Requirements:

1. Division 23 "HVAC Gravity Ventilators" for roof-mounted ventilator caps.
2. Division 23 "Diffusers, Registers and Grilles".
3. Division 28 "Digital, Addressable Fire-Alarm System" for duct-mounted fire and smoke detectors.
4. Division 28 "Zoned (DC-Loop) Fire-Alarm System" for duct-mounted fire and smoke detectors.

1.3 ACTION SUBMITTALS

- A. Product Data: For each type of product.

1. For duct silencers, include pressure drop and dynamic insertion loss data. Include breakout noise calculations for high transmission loss casings.

- B. LEED Submittals:

1. Product Data for Prerequisite IEQ 1: Documentation indicating that units comply with ASHRAE 62.1, Section 5 - "Systems and Equipment."
 2. Product Data for Prerequisite EA 2: Documentation indicating that duct insulation R-values comply with tables in ASHRAE/IESNA 90.1, Section 6 - "Heating, Ventilating, and Air Conditioning."
- C. Shop Drawings: For duct accessories. Include plans, elevations, sections, details and attachments to other work.
1. Detail duct accessories fabrication and installation in ducts and other construction. Include dimensions, weights, loads, and required clearances; and method of field assembly into duct systems and other construction. Include the following:
 - a. Special fittings.
 - b. Manual volume damper installations.
 - c. Control-damper installations.
 - d. Fire-damper, smoke-damper, combination fire- and smoke-damper, pressure relief-damper, ceiling, and corridor damper installations, including sleeves; and duct-mounted access doors and remote damper operators.
 - e. Wiring Diagrams: For power, signal, and control wiring.

1.4 INFORMATIONAL SUBMITTALS

- A. Coordination Drawings: Reflected ceiling plans, drawn to scale, on which ceiling-mounted access panels and access doors required for access to duct accessories are shown and coordinated with each other, using input from Installers of the items involved.
- B. Source quality-control reports.

1.5 CLOSEOUT SUBMITTALS

- A. Operation and Maintenance Data: For air duct accessories to include in operation and maintenance manuals.

1.6 MAINTENANCE MATERIAL SUBMITTALS

- A. Furnish extra materials that match products installed and that are packaged with protective covering for storage and identified with labels describing contents.
 1. Fusible Links: Furnish quantity equal to 10 percent of amount installed.

PART 2 - PRODUCTS

2.1 ASSEMBLY DESCRIPTION

- A. Comply with NFPA 90A, "Installation of Air Conditioning and Ventilating Systems," and with NFPA 90B, "Installation of Warm Air Heating and Air Conditioning Systems."
- B. Comply with SMACNA's "HVAC Duct Construction Standards - Metal and Flexible" for acceptable materials, material thicknesses, and duct construction methods unless otherwise indicated. Sheet metal materials shall be free of pitting, seam marks, roller marks, stains, discolorations, and other imperfections.

2.2 MATERIALS

- A. Galvanized Sheet Steel: Comply with ASTM A 653.
 - 1. Galvanized Coating Designation: G60.
 - 2. Exposed-Surface Finish: Mill phosphatized.
- B. Aluminum Sheets: Comply with ASTM B 209, Alloy 3003, Temper H14; with mill finish for concealed ducts and standard, 1-side bright finish for exposed ducts.
- C. Extruded Aluminum: Comply with ASTM B 221, Alloy 6063, Temper T6.
- D. Reinforcement Shapes and Plates: Galvanized-steel reinforcement where installed on galvanized sheet metal ducts; compatible materials for aluminum and stainless-steel ducts.
- E. Tie Rods: Galvanized steel, 1/4-inch minimum diameter for lengths 36 inches or less; 3/8-inch minimum diameter for lengths longer than 36 inches.

2.3 BACKDRAFT DAMPERS

- A. Manufacturers: Subject to compliance with requirements, provide products by one of the following:
 - 1. American Warming and Ventilating; a division of Mestek, Inc.
 - 2. Greenheck Fan Corporation.
 - 3. Nailor Industries Inc.
 - 4. Pottorff.
 - 5. Ruskin Company.
 - 6. United Enertech
- B. Function:
 - 1. Designed to allow airflow in one direction and prevent reverse airflow.
 - 2. Keeps outside air out of the space by sensing and closing against mass flow.
- C. Description:
 - 1. Gravity balanced.
- D. Maximum Air Velocity:
 - 1. 1000 fpm
- E. Maximum System Pressure:
 - 1. 3-inch wg.
- F. Frame: Hat-shaped, with welded corners or mechanically attached and mounting flange:
 - 1. 16GA 0.063-inch- thick extruded aluminum.
- G. Blades: Multiple single-piece blades, maximum 6-inch width noncombustible, tear-resistant, neoprene-coated fiberglass with sealed edges:
 - 1. Center pivoted: 16GA 0.050-inch- thick aluminum sheet.
- H. Blade Action: Parallel.
- I. Blade Seals: Mechanically locked.
 - 1. Neoprene.
- J. Blade Axles: 0.20 inch diameter:
 - 1. Material: Nonferrous metal.

- K. Tie Bars and Brackets:
 - 1. Aluminum.
- L. Return Spring: Adjustable tension.
- M. Bearings:
 - 1. Synthetic pivot bushings.
- N. Accessories.
 - 1. Adjustment device to permit setting for varying differential static pressure.
 - 2. Counterweights and spring-assist kits for vertical airflow installations.
 - 3. Screen Mounting: Front mounted in sleeve.
 - a. Sleeve Thickness: 20 gage minimum.
 - b. Sleeve Length: 6 inches minimum.
 - 4. Screen Mounting: Rear mounted.
 - 5. Screen Material:
 - a. Aluminum.
 - 6. Screen Type:
 - a. Bird
 - 7. 90-degree stops.

2.4 PRESSURE RELIEF DAMPERS

- A. Manufacturers: Subject to compliance with requirements, provide products by one of the following:
 - 1. American Warming and Ventilating; a division of Mestek, Inc.
 - 2. Greenheck Fan Corporation.
 - 3. Nailor Industries Inc.
 - 4. Pottorff.
 - 5. Ruskin Company.
- B. Function:
 - 1. Provide component designed to protect HVAC systems by relieving air pressure from within a space that is beyond a pre-determined limit.
 - 2. To automatically begin to open at a pre-set pressure difference above maximum system pressure.
 - 3. Internally self-controlled with system pressure utilizing adjustable arms and weights.
 - 4. Self-actuated with system pressure utilizing adjustable arms and weights.
 - 5. Employs blade counterbalancing.
 - 6. Automatically closes and re-sets when pressures return to normal conditions.
- C. Air Velocity:
 - 1. 3900 fpm.
- D. Maximum System Pressure (MSP):
 - 1. 5-inch wg.
- E. Differential Pressure Preset above MSP:
 - 1. 1-inch wg.
- F. Maximum Damper Pressure Limit:
 - 1. 5.0-inch wg.
- G. Frame Material: Flanged Channel:

1. 14GA 0.079-inch- thick galvanized steel.
- H. Frame Depth: 8-inch- minimum.
- I. Blades:
1. Material:
 - a. 16GA 0.063-inch- formed galvanized steel.
 2. Type:
 - a. Formed Sheetmetal.
 3. Blade-stop:
 - a. With stop.
- J. Blade Action: Parallel.
- K. Blade Seals:
1. Thermo Plastic Elastomer.
- L. Blade Axles:
1. Material:
 - a. Plated steel.
 2. Diameter: 0.375 inch.
- M. Linkage:
1. External heavy duty type with galvanized steel clevis arms and plated steel tie bars & pivot pins with nylon pivot bearings.
- N. Bearings:
1. Galvanized Steel ball.

2.5 BAROMETRIC RELIEF DAMPERS

- A. Manufacturers: Subject to compliance with requirements, provide products by one of the following:
1. American Warming and Ventilating; a division of Mestek, Inc.
 2. Greenheck Fan Corporation.
 3. Nailor Industries Inc.
 4. Pottorff.
 5. Ruskin Company.
- B. Function:
1. Senses and compares outdoor ambient and indoor pressures.
 2. Allows any higher pressure indoor air to escape.
- C. Description: Suitable for horizontal or vertical mounting.
- D. Maximum Air Velocity:
1. 1000 fpm
- E. Maximum System Pressure:
1. 3-inch wg.
- F. Frame: Hat-shaped, with welded corners or mechanically attached and mounting flange.
1. 13GA 0.094-inch- thick, galvanized sheet steel.
- G. Blades: Multiple:
1. 16GA 0.050-inch- thick aluminum sheet.

2. Maximum Width: 6 inches.
3. Action: Parallel.
4. Balance: Gravity.
5. Pivot:
 - a. Eccentric.

H. Blade Seals:

1. Neoprene

I. Blade Axles:

1. Galvanized steel.

J. Tie Bars and Brackets: Rattle free with 90-degree stop.

1. Material:
 - a. Galvanized steel.

K. Return Spring: Adjustable tension.

L. Bearings:

1. Synthetic

2.6 MANUAL VOLUME DAMPERS

A. Standard, Steel, Manual Volume Dampers:

1. Manufacturers: Subject to compliance with requirements, provide products by one of the following:
 - a. American Warming and Ventilating; a division of Mestek, Inc.
 - b. McGill AirFlow LLC.
 - c. Nailor Industries Inc.
 - d. Pottorff.
 - e. Ruskin Company.
 - f. United Enertech
2. Standard leakage rating , with linkage outside airstream .
3. Suitable for horizontal or vertical applications.
4. Frames: Hat-shaped, Mitered and welded corners. Flanges for attaching to walls and flangeless frames for installing in ducts.
 - a. 16GA 0.064-inch thick, galvanized sheet steel.
5. Blades:
 - a. Multiple or single blade. Parallel- or opposed-blade design. Stiffened damper blades for stability.
 - b. Material:
 - 1) Galvanized -steel, 16GA 0.064 inch thick.
6. Blade Axles:
 - a. Nonferrous metal
 - b. Shall extend full length of damper blades in ducts with pressure classes of 3-inch wg or more.
7. Bearings:
 - a. Material:
 - 1) Molded synthetic.
 - b. Bearings at both ends of damper operating shafts in ducts with pressure classes of 3-inch wg or more.

8. Tie Bars and Brackets: Galvanized steel.

B. Standard, Aluminum, Manual Volume Dampers:

1. Manufacturers: Subject to compliance with requirements, provide products by one of the following:
 - a. American Warming and Ventilating; a division of Mestek, Inc.
 - b. McGill AirFlow LLC.
 - c. Nailor Industries Inc.
 - d. Pottorff.
 - e. Ruskin Company.
 - f. United Enertech
2. Standard leakage rating, with linkage outside airstream.
3. Suitable for horizontal or vertical applications.
4. Frames: Hat-shaped, 0.10-inch- thick, aluminum sheet channels; frames with flanges for attaching to walls and flangeless frames for installing in ducts.
5. Blades:
 - a. Multiple or single blade.
 - b. Parallel- or opposed-blade design.
 - c. Stiffen damper blades for stability.
 - d. Roll-Formed Aluminum Blades: 0.10-inch- thick aluminum sheet.
 - e. Extruded-Aluminum Blades: 0.050-inch- thick extruded aluminum.
6. Blade Axles: Nonferrous metal.
7. Bearings:
 - a. Molded synthetic.
 - b. Dampers in ducts with pressure classes of 3-inch wg or more shall have axles full length of damper blades and bearings at both ends of operating shaft.
8. Tie Bars and Brackets: Aluminum.

C. Low-Leakage, Steel, Manual Volume Dampers:

1. Manufacturers: Subject to compliance with requirements, provide products by one of the following:
 - a. American Warming and Ventilating; a division of Mestek, Inc.
 - b. McGill AirFlow LLC.
 - c. Nailor Industries Inc.
 - d. Pottorff.
 - e. Ruskin Company.
 - f. United Enertech
2. Comply with AMCA 500-D testing for damper rating.
3. Low-leakage rating , with linkage outside airstream, and bearing AMCA's Certified Ratings Seal for both air performance and air leakage.
4. Suitable for horizontal or vertical applications.
5. Frames:
 - a. Frame: Hat-shaped,
 - 1) 16GA 0.064-inch thick, galvanized sheet steel.
 - b. Mitered and welded corners.
 - c. Flanges for attaching to walls and flangeless frames for installing in ducts.
6. Blades:

- a. Multiple or single blade.
 - b. Parallel- or opposed-blade design.
 - c. Stiffen damper blades for stability.
 - d. Material:
 - 1) Galvanized, roll-formed steel, 16GA 0.064 inch thick.
7. Blade Axles:
- a. Nonferrous metal.
8. Bearings:
- a. Molded synthetic.
 - b. Dampers in ducts with pressure classes of 3-inch wg or more shall have axles full length of damper blades and bearings at both ends of operating shaft.
9. Blade Seals:
- a. Neoprene.
10. Jamb Seals: Cambered Stainless steel or aluminum.
11. Tie Bars and Brackets: Galvanized steel or aluminum.
12. Accessories:
- a. Include locking device to hold single-blade dampers in a fixed position without vibration.
- D. Low-Leakage, Aluminum, Manual Volume Dampers:
1. Manufacturers: Subject to compliance with requirements, provide products by one of the following:
- a. American Warming and Ventilating; a division of Mestek, Inc.
 - b. Nailor Industries Inc.
 - c. McGill AirFlow LLC.
 - d. Pottorff.
 - e. Ruskin Company.
 - f. United Enertech
2. Comply with AMCA 500-D testing for damper rating.
3. Low-leakage rating, with linkage outside airstream, and bearing AMCA's Certified Ratings Seal for both air performance and air leakage.
4. Suitable for horizontal or vertical applications.
5. Frames: Hat-shaped, 0.10-inch- thick, aluminum sheet channels; frames with flanges for attaching to walls and flangeless frames for installing in ducts.
6. Blades:
- a. Multiple or single blade.
 - b. Parallel- or opposed-blade design.
 - c. Roll-Formed Aluminum Blades: 0.10-inch- thick aluminum sheet.
 - d. Extruded-Aluminum Blades: 0.050-inch- thick extruded aluminum.
7. Blade Axles: Nonferrous metal.
8. Bearings:
- a. Molded synthetic.
 - b. Dampers in ducts with pressure classes of 3-inch wg or more shall have axles full length of damper blades and bearings at both ends of operating shaft.
9. Blade Seals: Neoprene.
10. Jamb Seals: Cambered aluminum.
11. Tie Bars and Brackets: Aluminum.
12. Accessories:

- a. Include locking device to hold single-blade dampers in a fixed position without vibration.

E. Jackshaft:

1. Size:
 - a. 1-inch diameter.
2. Material: Galvanized-steel pipe rotating within pipe-bearing assembly mounted on supports at each mullion and at each end of multiple-damper assemblies.
3. Length and Number of Mountings: As required to connect linkage of each damper in multiple-damper assembly.

F. Damper Hardware:

1. Zinc-plated, die-cast core with dial and handle made of 3/32-inch- thick zinc-plated steel, and a 3/4-inch hexagon locking nut.
2. Include center hole to suit damper operating-rod size.
3. Include elevated platform for insulated duct mounting.

2.7 CONTROL DAMPERS

A. Manufacturers: Subject to compliance with requirements, provide products by one of the following:

1. Greenheck Fan Corporation.
2. Pottorff.
3. Ruskin Company.
4. Young Regulator Company.
5. United Enertech

B. Low-leakage rating, with linkage outside airstream, and bearing AMCA's Certified Ratings Seal for both air performance and air leakage.

C. Frames:

1. Section:
 - a. Hat shaped.
2. Material:
 - a. 20 GA 0.40-inch- thick galvanized steel .
3. Corners:
 - a. Mitered-and-welded.

D. Blades: Multiple.

1. Maximum blade width:
 - a. 6 inches.
2. Opposed -blade design.
3. Material:
 - a. Galvanized-steel.
4. Thickness:
 - a. 20 GA 0.40-inch- thick galvanized steel
5. Blade Edging: Inflatable seal blade edging, or replaceable rubber seals.
 - a. Closed-cell neoprene

E. Blade Axles:

1. Section:
 - a. 3/8-inch-square

2. Material:
 - a. Galvanized steel.
3. Blade-linkage hardware:
 - a. Zinc-plated steel and brass.
 - b. Ends sealed against blade bearings:
4. Operating Temperature Range: From minus 40 to plus 200 deg F.

F. Bearings:

1. Type:
 - a. Molded synthetic.
2. Axles: Dampers in ducts with pressure classes of 3-inch wg or more shall have axles full length of damper blades.
3. Bearings: Thrust bearings at each end of every blade. Bearings at both ends of each operating shaft.

2.8 FIRE DAMPERS

A. Manufacturers: Subject to compliance with requirements, provide products by one of the following:

1. Arrow United Industries; a division of Mestek, Inc.
2. Greenheck Fan Corporation.
3. Nailor Industries Inc.
4. Pottorff.
5. Ruskin Company.
6. United Enertech

B. Type:

1. Dynamic.

C. Standard: Rated and labeled according to UL 555 by an NRTL.

D. Closing rating in ducts up to 4-inch wg static pressure class and minimum 2000-fpm velocity.

E. Fire Rating:

1. 1-1/2 hours.

F. Frame:

1. Curtain type with blades outside airstream.
2. Material:
 - a. Fabricated with roll-formed galvanized steel; with mitered and interlocking corners.
 - b. Thickness:
 - 1) 20GA-0.040-inch-.

G. Mounting Sleeve: Factory- or field-installed, galvanized sheet steel. Length to suit application.

1. Minimum Thickness:
 - a. 18GA-0.05 inch, as indicated.
2. Exception: Omit sleeve where damper-frame width permits direct attachment of perimeter mounting angles on each side of wall or floor; thickness of damper frame must comply with sleeve requirements.

H. Mounting Orientation: Vertical or horizontal as indicated.

I. Blades: Roll-formed, interlocking, galvanized sheet steel.

1. Thickness:

- a. 24GA-0.024-inch-
- 2. In place of interlocking blades, use full-length, 0.034-inch- thick, galvanized-steel blade connectors.
- J. Horizontal Dampers: Include blade lock and Type 301 constant force stainless-steel closure spring.
- K. Heat-Responsive Device: Replaceable, 212 deg F rated, fusible links.
- L. Accessories:
 - 1. Auxiliary switches for signaling:
 - a. Position indication.

2.9 SMOKE DAMPERS

- A. Manufacturers: Subject to compliance with requirements, provide products by one of the following:
 - 1. Greenheck Fan Corporation.
 - 2. Nailor Industries Inc.
 - 3. Pottorff.
 - 4. Ruskin Company.
 - 5. United Enertech
- B. General Requirements: Label according to UL 555S by an NRTL.
- C. Smoke Detector: See electrical for smoke detector requirements.
- C. Frame: Galvanized sheet steel. With or without mounting flange as required.
 - 1. Thickness:
 - a. Hat-shaped, 16GA-0.064-inch.
 - 2. Corners:
 - a. Welded.
- D. Blades: Horizontal, galvanized sheet steel.
 - 1. Section;
 - a. Roll-formed.
 - 2. Fit:
 - a. Interlocking.
 - 3. Thickness:
 - a. 14GA-0.079-inch.
- E. Leakage:
 - 1. Class II.
- F. Seals:
 - 1. Blade: Inflatable silicone fiberglass material to maintain smoke leakage rating to a minimum of 450 deg F.
- G. Rated pressure and velocity to exceed design airflow conditions.
- H. Mounting Sleeve: Factory-installed, galvanized sheet steel; length to suit wall or floor application with factory-furnished silicone calking.
 - 1. Minimum 17-inches long.
 - 2. Thickness:
 - a. 0.05-inch-.

- I. Damper Motors: Damper motors to be Belimo or approved equal. Honeywell motors are not allowed.
 - 1. Action:
 - a. Two-position
 - 2. Mode: Fail close.
 - 3. Mounting: External.

- J. Comply with NEMA designation, temperature rating, service factor, enclosure type, and efficiency requirements for motors specified in Section 230513 "Common Motor Requirements for HVAC Equipment."
 - 1. Electrical Connection: 115 V, single phase, 60 Hz .

- K. Accessories:
 - 1. Auxiliary switches for signaling:
 - a. Position indication.
 - 2. Test Switch type:
 - a. Momentary test switch.
 - 3. Test Switch Mounting:
 - a. Damper.

2.10 COMBINATION FIRE AND SMOKE DAMPERS

- A. Manufacturers: Subject to compliance with requirements, provide products by one of the following:
 - 1. Greenheck Fan Corporation.
 - 2. Nailor Industries Inc.
 - 3. Pottorff.
 - 4. Ruskin Company.
 - 5. United Enertech

- B. Type: Dynamic; rated and labeled according to UL 555 and UL 555S by an NRTL.

- C. Closing rating in ducts up to 4-inch wg static pressure class and minimum velocity of:
 - 1. 4000-fpm

- D. Fire Rating:
 - 1. 1-1/2 hours.

- E. Frame: Hat shaped, galvanized sheet steel. With or without mounting flange as required.
 - 1. Thickness:
 - a. 16GA-0.064-inch
 - 2. Corners:
 - a. Welded.

- F. Heat-Responsive Device: Replaceable, 212 deg F rated, fusible links.

- G. Blades: Horizontal, galvanized sheet steel.
 - 1. Type:
 - a. Air-foil.
 - 2. Fit:
 - a. Interlocking.
 - 3. Thickness:
 - a. 0.063-inch-.

- H. Leakage:
 - 1. Class I.

- I. Rated pressure and velocity to exceed design airflow conditions.
- J. Mounting Sleeve: Factory-installed, galvanized sheet steel; length to suit wall or floor application with factory-furnished silicone caulking.
 - 1. Thickness:
 - a. 18GA 0.05-inch.
- K. Master control panel for use in dynamic smoke-management systems.
- L. Damper Motors: Damper Motors to be Belimo or approved equal. Honeywell motors are not allowed.
 - 1. Locate outside air stream unless otherwise indicated.
 - 2. Action: Two-position.
 - 3. Voltage: to match fire alarm system (coordinate).
 - 4. Listed: UL, as part of damper assembly.
 - 5. Outdoor Motors and Motors in Outside-Air Intakes:
 - a. Gaskets: O-ring gaskets designed to make motors weatherproof.
 - b. Internal Heaters: Equip to permit normal operation at minus 40 deg F.
- M. Comply with NEMA designation, temperature rating, service factor, enclosure type, and efficiency requirements for motors specified in Section 230513 "common Motor Requirements for HVAC Equipment."
 - 1. Electrical Connection: 115 V, single phase, 60 Hz.
- N. Monitoring: All combination fire & smoke dampers are to have the following parameters monitored as part of the fire alarm system:
 - 1. Damper status.
 - 2. Damper Position.
- O. Accessories:
 - 1. Auxiliary switches:
 - a. Signaling.
 - b. Position Indication.
 - 2. Test Switch Type:
 - a. Momentary test switch.
 - 3. Test Switch Mounting:
 - a. Damper.

2.11 DUCT SILENCERS

- A. Manufacturers: Subject to compliance with requirements, provide products by one of the following:
 - 1. Industrial Acoustics Company.
 - 2. Ruskin Company.
 - 3. SEMCO Incorporated.
 - 4. Vibro-Acoustics.
- B. General Requirements:
 - 1. Factory fabricated.
 - 2. Fire-Performance Characteristics: Adhesives, sealants, packing materials, and accessory materials shall have flame-spread index not exceeding 25 and smoke-developed index not exceeding 50 when tested according to ASTM E 84.
 - 3. Airstream Surfaces: Surfaces in contact with the airstream shall comply with requirements in ASHRAE 62.1.
- C. Shape:

1. Rectangular straight with splitters or baffles.
 2. Round straight with center bodies or pods.
 3. Rectangular elbow with splitters or baffles.
 4. Round elbow with center bodies or pods.
 5. Rectangular transitional with splitters or baffles.
- D. Rectangular Silencer Outer Casing: Galvanized sheet steel.
1. ASTM A 653:
 - a. G60.
 2. Thickness:
 - a. 22GA-0.034 inch.
- E. Round Silencer Outer Casing: Galvanized sheet steel.
1. ASTM A 653:
 - a. G60.
 2. Sheet Metal Thickness for Units up to 24 Inches in Diameter: 22GA-0.034 inch thick.
 3. Sheet Metal Thickness for Units 26 through 40 Inches in Diameter: 20GA-0.040 inch thick.
 4. Sheet Metal Thickness for Units 42 through 52 Inches in Diameter: 18GA-0.05 inch thick.
 5. Sheet Metal Thickness for Units 54 through 60 Inches in Diameter: 16GA-0.064 inch thick.
- F. Inner Casing and Baffles: Galvanized sheet metal with 1/8-inch- diameter perforations.
1. ASTM A 653:
 - a. G60.
 2. Thickness:
 - a. 22GA-0.034 inch.
- G. Special Construction:
1. Suitable for outdoor use.
 2. High transmission loss to achieve STC 45.
- H. Connection Sizes: Match connecting ductwork unless otherwise indicated.
- I. Principal Sound-Absorbing Mechanism:
1. Controlled impedance membranes and broadly tuned resonators without absorptive media.
 2. Dissipative or Film-lined type with fill material:
 - a. Fill Material: Inert and vermin-proof fibrous material, packed under not less than 15 percent compression
 - b. Erosion Barrier: Polymer bag enclosing fill, and heat sealed before assembly.
 - c. Prohibited: Mineral wool will not be permitted as a substitute for glass fiber.
 3. Lining:
 - a. Material:
 - 1) Tedlar
 - b. Prohibited: Mesh, screen or corrugated perforated liner will not be acceptable as a substitute for the specified spacer.
- J. Fabricate silencers to form rigid units that will not pulsate, vibrate, rattle, or otherwise react to system pressure variations. Do not use mechanical fasteners for unit assemblies.
1. Joints:
 - a. Lock formed and sealed.

2. Suspended Units: Factory-installed suspension hooks or lugs attached to frame in quantities and spaced to prevent deflection or distortion.
3. Reinforcement: Cross or trapeze angles for rigid suspension.
4. Structural Criteria: The silencers shall not fail structurally when subjected to a differential air pressure of 8 inches water gage.
5. Spot Welds: All spot welds shall be painted.

K. Accessories:

1. Integral 1-1/2-hour fire damper with access door. Access door to be high transmission loss to match silencer.
2. Factory-installed end caps to prevent contamination during shipping.
3. Removable splitters.
4. Airflow measuring devices.

2.12 TURNING VANES

A. Manufacturers: Subject to compliance with requirements, provide products by one of the following:

1. METALAIRE, Inc.
2. SEMCO Incorporated.
3. Ward Industries, Inc.; a division of Hart & Cooley, Inc.

B. Manufactured Turning Vanes for Metal Ducts: Curved blades of galvanized sheet steel; support with bars perpendicular to blades set; set into vane runners suitable for duct mounting.

1. Fabricate single blade vanes to comply with SMACNA's "HVAC Duct Construction Standards-Metal and Flexible."
2. Acoustic Turning Vanes: Fabricate airfoil-shaped aluminum extrusions with perforated faces and fibrous-glass fill.

C. Manufactured Turning Vanes for Nonmetal Ducts: Fabricate curved blades of resin-bonded fiberglass with acrylic polymer coating; support with bars perpendicular to blades set; set into vane runners suitable for duct mounting.

D. General Requirements: Comply with SMACNA's "HVAC Duct Construction Standards - Metal and Flexible"; Figures 4-3, "Vanes and Vane Runners," and 4-4, "Vane Support in Elbows."

E. Vane Construction:

1. Single wall

F. Vane Spacing:

1. 1-1/2" spacing between turning vanes
2. 3-1/4" spacing not allowed.

G. Vane Construction: Single wall for ducts up to 36 inches wide and additional bracing for larger dimensions.

2.13 REMOTE DAMPER OPERATORS

A. Manufacturers: Subject to compliance with requirements, provide products by one of the following:

1. Pottorff.
2. Ruskin Company; Tomkins PLC.

- B. Cable Type:
 - 1. Description: Cable system designed for remote manual damper adjustment.
 - 2. Tubing/Sheathing: Galvanized, Brass, Copper or Aluminum.
 - 3. Cable: Stainless steel or Steel.
 - 4. Wall-Box Mounting: Coordinate with Architect.
 - 5. Wall-Box Cover-Plate Material: Coordinate with Architect.

- C. Activated Electric Type:
 - 1. Description: Electrically activated zone control damper for remote adjustment. When an adjustment is needed the system is powered up.
 - 2. Means: Factory mounted actuator factory wired to damper.
 - 3. Portable 9 volt system. No field power requirement.
 - 4. Mounting: Recessed Wall Box or Diffuser or Hand Held.
 - 5. Wall-Box Cover Finish: Coordinate with Architect.
 - 6. Wall-Box Porting: 1 to 6 ports or more.

2.14 DUCT-MOUNTED ACCESS DOORS

- A. Manufacturers: Subject to compliance with requirements, provide products by one of the following:
 - 1. Greenheck Fan Corporation.
 - 2. McGill AirFlow LLC.
 - 3. Pottorff.
 - 4. Ward Industries, Inc.; a division of Hart & Cooley, Inc.
 - 5. Ruskin Company

- B. Duct-Mounted Access Doors: Fabricate access panels according to SMACNA's "HVAC Duct Construction Standards - Metal and Flexible"; Figures 7-2, "Duct Access Doors and Panels," and 7-3, "Access Doors - Round Duct."
 - 1. Door:
 - a. Double wall, rectangular.
 - b. Galvanized sheet metal with insulation fill and thickness as indicated for duct pressure class.
 - c. Hinges and Latches: 1-by-1-inch butt or piano hinge and cam latches.
 - d. Fabricate doors airtight and suitable for duct pressure class.

 - 2. Frame: Galvanized sheet steel, with bend-over tabs and foam gaskets.
 - 3. Number of Hinges and Locks:
 - a. Access Doors Less Than 12 Inches Square: No hinges and two sash locks.
 - b. Access Doors up to 18 Inches Square:
 - 1) Hinges:
 - a) Two hinges and two sash locks.
 - c. Access Doors up to 24 by 48 Inches, provide outside and inside handles:
 - 1) Hinges:
 - a) Three hinges and two compression latches.
 - d. Access Doors Larger Than 24 by 48 Inches, provide outside and inside handles:
 - 1) Hinges:
 - a) Continuous and two compression latches with outside and inside handles.

2.15 FLEXIBLE CONNECTORS

- A. Manufacturers: Subject to compliance with requirements, provide products by one of the following:
1. Ductmate Industries, Inc.
 2. Ventfabrics, Inc.
 3. Ward Industries, Inc.; a division of Hart & Cooley, Inc.
- B. Materials: Flame-retardant or noncombustible fabrics.
- C. Coatings and Adhesives: Comply with UL 181, Class 1.
- D. Metal-Edged Connectors: Factory fabricated with a wide fabric strip attached to two narrower metal strips. Provide strips of metal compatible with connected ducts.
1. Wide Strip:
 - a. 3-1/2 inches.
 2. Narrow Strips:
 - a. 0.028-inch- thick, galvanized sheet steel.
- E. Indoor System, Flexible Connector Fabric: Glass fabric double coated with neoprene.
1. Minimum Weight: 26 oz./sq. yd..
 2. Tensile Strength: 530 lbf/inch in the warp and 440 lbf/inch in the filling.
 3. Service Temperature: Minus 40 to plus 200 deg F.
- F. Outdoor System, Flexible Connector Fabric: Glass fabric double coated with weatherproof, synthetic rubber resistant to UV rays and ozone.
1. Minimum Weight: 24 oz./sq. yd..
 2. Tensile Strength: 530 lbf/inch in the warp and 440 lbf/inch in the filling.
 3. Service Temperature: Minus 50 to plus 250 deg F.

2.16 DUCT SECURITY BARS

- A. Manufacturers: Subject to compliance with requirements, provide products by one of the following:
1. Carnes.
 2. KEES, Inc.
 3. Lloyd Industries, Inc.
 4. Metal Form Manufacturing, Inc.
 5. Price Industries.
 6. Titus
 7. Krueger
- B. Description: Factory-fabricated and field-installed duct security bars.
- C. Configuration:
1. Frame: 1-1/2 by 1-1/2 by 3/16 inch angle.
 2. Sleeve: 3/16-inch, continuously welded steel frames with 1-1/2-by-1-1/2-by-1/8- angle frame furnished loose for field welding on other end. To be poured in place or set with concrete block or welded or bolted to wall, one side only. Duct connections on both sides.
 3. Horizontal Bars: 3/4 inch steel.
 4. Vertical Bars: 3/4 inch steel
 5. Bar Spacing: 6 inches.

6. Mounting: Ductwork or other framing.

- D. Finish:
1. White

2.17 FLEXIBLE DUCTS

- A. Manufacturers: Subject to compliance with requirements, provide products by one of the following:
1. Flexmaster U.S.A., Inc.
 2. McGill AirFlow LLC.
 3. Themaflex
 4. Ward Industries, Inc.; a division of Hart & Cooley, Inc.
- B. Ducts shall conform to the requirements for Class I connectors when tested in accordance with "Standard for Factory Made Air Ducts Materials and Air Duct Connectors" (UL 181).
- C. Ducts shall also pass the 15 minute U.L. flame penetration test as specified in the UL 181 Standard.
- D. Insulated, Flexible Duct: Two-ply vinyl film supported by helically wound, spring-steel wire; fibrous-glass insulation; polyethylene or aluminized vapor-barrier film.
1. Pressure Rating: 10-inch wg positive and 1.0-inch wg negative.
 2. Maximum Air Velocity: 4000 fpm.
 3. Temperature Range: Minus 10 to plus 160 deg F.
 4. Insulation R-value: Comply with ASHRAE/IESNA 90.1.
- E. Flexible Duct Connectors:
1. Clamps: in sizes 3 through 18 inches, to suit duct size.
 - a. Material: Stainless-steel band with cadmium-plated hex screw to tighten band with a worm-gear action.
 - b. Clamps must be approved and listed with a UL181B-C listing.
 2. Nylon Duct Cable Tie: In sizes 3 through 18 inches, to suit duct size.
 - a. Material: Nylon
 - b. Fastener must be approved and listed with a UL181B-C listing.
 3. Adhesive Tape:
 - a. Material: Metalized polypropylene.
 - b. Tape must be approved and listed with a UL181B-FX listing.

2.18 DUCT ACCESSORY HARDWARE

- A. Instrument Test Holes: Cast iron or cast aluminum to suit duct material, including screw cap and gasket. Size to allow insertion of pitot tube and other testing instruments and of length to suit duct-insulation thickness.
- B. Adhesives: High strength, quick setting, neoprene based, waterproof, and resistant to gasoline and grease.
- C. Splitter Damper Accessories: Zinc-plated damper blade bracket; 1/4-inch, zinc-plated operating rod; and a duct-mounted, ball-joint bracket with flat rubber gasket and square-head set screw.
- D. Flexible Duct Clamps: Stainless-steel band with cadmium-plated hex screw to tighten band with a worm-gear action, in sizes 3 to 18 inches to suit duct size.

2.19 HIGH EFFICIENCY TAKE-OFFS

- A. Manufacturers: Subject to compliance with requirements, provide products by one of the following.
 - 1. Air-Rite
 - 2. Hercules Industries
 - 3. Sheet Metal Connectors, Inc.
 - 4. Spiral Manufacturing Co. Inc.
 - 5. Ferguson
- B. Materials:
 - 1. 24 gauge galvanized sheet metal meeting ASTM A653 and A924
- C. Take-off shall meet SMACNA third edition Section 4.8 figure 4.6 - 45 degree entry.
- D. Rectangular opening with flanged sides on all sides. Complete with closed cell neoprene gasket to provide a tight seal.
- E. Zeros VOC's

PART 3 - EXECUTION

3.1 INSTALLATION

General

- A. Install duct accessories according to applicable details in SMACNA's "HVAC Duct Construction Standards - Metal and Flexible" for metal ducts and in NAIMA AH116, "Fibrous Glass Duct Construction Standards," for fibrous-glass ducts.
- B. Install duct accessories of materials suited to duct materials; use galvanized-steel accessories in galvanized-steel and fibrous-glass ducts, stainless-steel accessories in stainless-steel ducts, and aluminum accessories in aluminum ducts.
- C. Use the Remote Damper Operator when they are called out on the drawings or when the damper cannot be easily accessed.
- D. Install duct security bars. Construct duct security bars from 3/16-inch steel sleeve, continuously welded at all joints and 3/4-inch- diameter steel bars, 6 inches o.c. in each direction in center of sleeve. Weld each bar to steel sleeve and each crossing bar. Weld 1-1/2-by-1-1/2-by-1/8- steel angle to 4 sides and both ends of sleeve. Connect duct security bars to ducts with flexible connections. Provide 12-by-12-inch hinged access panel with cam lock in duct in each side of sleeve.
- E. Install high efficiency take-off on all branch duct take-offs. Provide take-off with balancing damper as shown on drawings. Spin-in fittings are not allowed.

Flexible Ducts / Flexible Duct Connectors

- F. Install flexible connectors to connect ducts to equipment.
- G. Flexible duct connections from the main trunk ducts to diffuser boots shall be furnished and installed as shown on the drawings. Flexible ductwork shall only be used as indicated on the drawings.

- H. Where flexible duct is indicated, use insulated flexible duct for supply air return and exhaust air.
- I. Flexible ductwork shall be run in straight lengths.
- J. Provide support in flexible duct every three feet.
- K. Flexible ducts shall have compression fittings on both ends.
- L. Flexible ductwork is not allowed to bend 90 degrees. If a bend is needed use sheet-metal hard elbows. Hard turns, offsets, or kinks will not be allowed.
- M. Flexible ducts shall connect to trunk duct with high efficiency takeoffs.
- N. Connect flexible ducts to metal ducts with draw bands.
- O. Connect ducts to duct silencers:
 - 1. With flexible duct connectors.
- P. Connect terminal units to supply ducts:
 - 1. With maximum 12-inch lengths of flexible duct.
- Q. Do not use flexible ducts to change directions.
- R. Connect diffusers or light troffer boots to ducts:
 - 1. With maximum 60-inch lengths of flexible duct clamped or strapped in place.

Backdraft/Control/Pressure Relief Dampers

- S. Install backdraft dampers at inlet of exhaust fans or exhaust ducts as close as possible to exhaust fan unless otherwise indicated.
- T. Install pressure relief damper immediately upstream of main fire damper.

Volume Damper

- U. Install volume dampers at points on supply, return, and exhaust systems where branches extend from larger ducts. Where dampers are installed in ducts having duct liner, install dampers with hat channels of same depth as liner, and terminate liner with nosing at hat channel.
 - 1. Install steel volume dampers in steel ducts.
 - 2. Install aluminum volume dampers in aluminum ducts.
- V. Set dampers to fully open position before testing, adjusting, and balancing. Exception: Pressure relief damper.
- W. A balance damper with locking quadrant will be provided downstream of take-off from trunk duct.

Fans And Test Holes

- X. For fans developing static pressures of 5-inch wg and more, cover flexible connectors with loaded vinyl sheet held in place with metal straps.
- Y. Install thrust limits at centerline of thrust, symmetrical on both sides of equipment. Attach thrust limits at centerline of thrust and adjust to a maximum of 1/4-inch movement during start and stop of fans.

- Z. Install duct test holes where required for testing and balancing purposes.
- AA. Install test holes at fan inlets and outlets and elsewhere as indicated.

FIRE, SMOKE AND FIRE-SMOKE DAMPERS

- BB. Install fire and smoke dampers according to UL listing.
 - 1. Install fusible links in fire dampers.
- CC. For round ductwork 24-inch and smaller a true round fire damper with the same rating may be used.

Access Doors

- DD. Install duct access doors on sides of ducts to allow for inspecting, adjusting, and maintaining accessories and equipment at the following locations:
 - 1. On upstream side of duct coils.
 - 2. Upstream from duct filters.
 - 3. At outdoor-air intakes and mixed-air plenums.
 - 4. At drain pans and seals.
 - 5. Downstream from manual volume dampers, control dampers, backdraft dampers, and equipment.
 - 6. Adjacent to and close enough to fire or smoke dampers, to reset or reinstall fusible links. Access doors for access to fire or smoke dampers having fusible links shall be standard access doors and shall be outward operation for access doors installed upstream from dampers and inward operation for access doors installed downstream from dampers.
 - 7. At each change in direction and at maximum 50-foot spacing.
 - 8. Upstream from turning vanes.
 - 9. Upstream or downstream from duct silencers.
 - 10. Control devices requiring inspection.
 - 11. Elsewhere as indicated.
 - 12. On upstream side of duct reheat coils. (between Phoenix valve and reheat coil)
- EE. Install access doors with swing against duct static pressure.
- FF. Access Door Sizes:
 - 1. One-Hand or Inspection Access: 8 by 5 inches.
 - 2. Two-Hand Access: 12 by 6 inches.
 - 3. Head and Hand Access: 18 by 10 inches.
 - 4. Head and Shoulders Access: 21 by 14 inches.
 - 5. Body Access: 25 by 14 inches.
 - 6. Body plus Ladder Access: 25 by 17 inches.
- GG. Label access doors according to Section 230553 "Identification for HVAC Piping and Equipment" to indicate the purpose of access door.

3.2 FIELD QUALITY CONTROL

- A. Tests and Inspections:
 - 1. Operate dampers to verify full range of movement.
 - 2. Inspect locations of access doors and verify that purpose of access door can be performed.
 - 3. Operate fire, smoke, and combination fire and smoke dampers to verify full range of movement and verify that proper heat-response device is installed.

4. Inspect turning vanes for proper and secure installation.
5. Operate remote damper operators to verify full range of movement of operator and damper.

3.3 ADJUSTING

- A. Adjust duct accessories for proper settings.
- B. Adjust fire and smoke dampers for proper action.
- C. Final positioning of manual-volume dampers is specified in Division 23 Section "Testing, Adjusting, and Balancing for HVAC."

END OF SECTION 23 3300

SECTION 23 3423

HVAC POWER VENTILATORS

PART 1 - GENERAL

1.1 RELATED DOCUMENTS

- A. Drawings and general provisions of the Contract, including General and Supplementary Conditions and Division 01 Specification Sections, apply to this Section.

1.2 SUMMARY

- A. Section Includes:
 - 1. Utility set fans.
 - 2. Centrifugal roof ventilators.
 - 3. Centrifugal wall ventilators.
 - 4. Ceiling-mounted ventilators.
 - 5. In-line centrifugal fans.
 - 6. Propeller fans.
 - 7. Dryer booster fans

1.3 PERFORMANCE REQUIREMENTS

- A. Project Altitude: Base fan-performance ratings on:
 - 1. Actual Project site elevations.
- B. Operating Limits: Classify according to AMCA 99.
- C. Fan Schedule: Fan characteristics and performance data are described in an equipment schedule on the drawings including:
 - 1. Fan arrangement with wheel configuration, inlet and discharge configurations, and required accessories.
 - 2. Capacities, outlet velocities, static pressures, sound power characteristics, motor requirements, and electrical characteristics.

1.4 ACTION SUBMITTALS

- A. Product Data: For each type of product indicated. Include rated capacities, shipping weights, operating weights, operating characteristics, and furnished specialties and accessories. Also include the following:
 - 1. Certified fan performance curves with system operating conditions indicated.
 - 2. Certified fan sound-power ratings.
 - 3. Motor ratings and electrical characteristics, plus motor and electrical accessories.
 - 4. Material thickness and finishes, including color charts.
 - 5. Dampers, including housings, linkages, and operators.
 - 6. Roof curbs.
 - 7. Fan speed controllers.
- B. Shop Drawings: Include plans, elevations, sections, details, and attachments to other work.

1. Detail equipment assemblies and indicate dimensions, weights, loads, required clearances, method of field assembly, components, and location and size of each field connection.
 2. Wiring Diagrams: For power, signal, and control wiring.
 - a. Detail all wiring systems and differentiate clearly between manufacturer-installed and field-installed wiring.
- C. Delegated-Design Submittal: For unit hangars and supports indicated to comply with performance requirements and design criteria, including analysis data signed and sealed by the qualified professional engineer responsible for their preparation.
1. Vibration Isolation Base Details: Detail fabrication including anchorages and attachments to structure and to supported equipment. Include adjustable motor bases, rails, and frames for equipment mounting.
 2. Design Calculations: Calculate requirements for selecting vibration isolators and seismic restraints and for designing vibration isolation bases.

1.5 INFORMATIONAL SUBMITTALS

- A. Coordination Drawings: Reflected ceiling plans and other details, drawn to scale, on which the following items are shown and coordinated with each other, using input from Installers of the items involved:
1. Roof framing and support members relative to duct penetrations.
 2. Ceiling suspension assembly members.
 3. Size and location of initial access modules for acoustical tile.
 4. Ceiling-mounted items including light fixtures, diffusers, grilles, speakers, sprinklers, access panels, and special moldings.
- B. Field quality-control Reports

1.6 CLOSEOUT SUBMITTALS

- A. Operation and Maintenance Data: For power ventilators to include in emergency, operation, and maintenance manuals.

1.7 MATERIALS MAINTENANCE SUBMITTALS

- A. Furnish extra materials that match products installed and that are packaged with protective covering for storage and identified with labels describing contents.
1. Belts: One set for each belt-driven unit.

1.8 QUALITY ASSURANCE

- A. Electrical Components, Devices, and Accessories: Listed and labeled as defined in NFPA 70, by a qualified testing agency, and marked for intended location and application.
- B. AMCA Compliance: Fans shall have AMCA-Certified performance ratings and shall bear the AMCA-Certified Ratings Seal.
- C. NEMA Compliance: Power ventilator electrical components shall comply with applicable NEMA standards.
- D. UL Standards: Power ventilators shall comply with UL 705. Power ventilators for use for restaurant kitchen exhaust shall also comply with UL 762.

1.9 COORDINATION

- A. Coordinate size and location of structural-steel support members.
- B. Coordinate sizes and locations of concrete bases with actual equipment provided.
- C. Coordinate sizes and locations of roof curbs, equipment supports, and roof penetrations with actual equipment provided.

PART 2 - PRODUCTS

2.1 PRODUCTS FURNISHED BUT NOT INSTALLED

- A. Products furnished, but not installed, under this Section include roof curbs for roof-mounted exhaust fans. Roof curbs to be installed by Division 07, section "Roof Accessories".

2.2 UTILITY SET FANS

- A. Manufacturers: Subject to compliance with requirements, provide products by one of the following:
 - 1. Aerovent; a division of Twin City Fan Companies, Ltd.
 - 2. Greenheck Fan Corp.
 - 3. Hartzell Fan Incorporated.
 - 4. Loren Cook Company.
 - 5. New York Blower Company (The).
 - 6. PennBarry.
 - 7. Twin City
- B. Housing: Fabricated of steel with side sheets fastened with a deep lock seam or welded to scroll sheets.
 - 1. Housing Discharge Arrangement: Adjustable to eight standard positions.
- C. Fan Wheels: Single-width, single inlet; welded to cast-iron or cast-steel hub and spun-steel inlet cone, with hub keyed to shaft.
 - 1. Blade Materials:
 - a. Steel
 - 2. Blade Type:
 - a. Airfoil
- D. Belt-Driven Units: Motor mounted on adjustable base, with adjustable sheaves.
 - 1. Fan Shaft: Turned, ground, and polished steel; keyed to wheel hub.
 - 2. Shaft Bearings: Prelubricated and sealed, self-aligning, pillow-block-type ball bearings with ABMA 9:
 - a. L₅₀ of 200,000 hours.
 - b. External Lubrication Lines: Lubricating tubes from fan bearings extended to accessible location outside of fan housing.
 - 3. Belt drives factory mounted, with final alignment and belt adjustment made after installation
 - 4. Service Factor Based on Fan Motor Size:
 - a. 1.5
 - 5. Motor Pulleys: Adjustable pitch for use with motors through 5 hp; fixed pitch for use with larger motors. Select pulley so pitch adjustment is at the middle of adjustment range at fan design conditions.
 - 6. Belts: Oil resistant, nonsparking, and nonstatic; matched sets for multiple belt drives.
 - 7. Belt Guards: Fabricate of steel for motors mounted on outside of fan cabinet.

8. Fan Guard: 1/2- by 1-inch mesh of galvanized steel in removable frame. Provide guard for inlet and/or outlet on units not connected to ductwork, where contact with fan wheel is within personal reach through access opening, or where falling objects and/or debris may enter fan.

E. Accessories:

1. Inlet Screens: Removable wire mesh.
2. Disconnect Switch: Nonfusible type:
 - a. Thermal-overload protection; factory wired through an internal aluminum conduit.
 - 1) Mounted inside fan housing.

2.3 CENTRIFUGAL ROOF VENTILATORS

A. Manufacturers: Subject to compliance with requirements, provide products by one of the following:

1. Aerovent; a division of Twin City Fan Companies, Ltd.
2. Greenheck Fan Corporation.
3. Loren Cook Company.
4. PennBarry.
5. Twin City.

B. Housing: Removable: Square, one-piece, aluminum base with venture inlet cone.

1. Spun-aluminum, dome top and outlet baffle.
2. Upblast Units: Provide spun-aluminum discharge baffle to direct discharge air upward, with rain and snow drains [and grease collector].
3. Hinged Subbase: Galvanized-steel hinged arrangement permitting service and maintenance.

C. Fan Wheels:

1. Aluminum hub and wheel with backward-inclined blades.

D. Direct-Drive Units: Motor mounted outside of airstream within fan housing.

E. Belt-Driven Units: Motor mounted on adjustable base, adjustable sheaves and with motor and belts within fan housing.

F. Accessories:

1. Variable-Speed Controller: Solid-state control to reduce speed from 100 to less than 50 percent.
2. Disconnect Switch: Nonfusible type:
 - a. Thermal-overload protection; factory wired through an internal aluminum conduit.
 - 1) Mounted inside fan housing.
3. Bird Screens: Removable, 1/2-inch mesh:
 - a. Aluminum wire.
4. Dampers:
 - a. Counterbalanced, parallel-blade, backdraft dampers mounted in curb base; factory set to close when fan stops.
 - b. Motorized parallel-blade dampers mounted in curb base with electric actuator; wired to close when fan stops.

G. Roof Curbs: Galvanized steel; mitered and welded corners; 1-1/2-inch thick, rigid, fiberglass insulation adhered to inside walls; and 1-1/2-inch wood nailer. Size as required to suit roof opening and fan base. Provide neoprene gasket between fan base and curb to reduce sound transmission.

1. Configuration:

- a. Self-flashing without a cant strip, with mounting flange.
2. Overall Height:
 - a. 14 inches.

H. KITCHEN CENTRIFUGAL UPBLAST EXHAUSTERS

1. Spark-Resistant Construction: AMCA 99, Type B.
2. Refer to Division 23 Section "Motors" for general requirements for factory-installed motors.

2.4 CENTRIFUGAL WALL VENTILATORS

- A. Manufacturers: Subject to compliance with requirements, provide products by one of the following:
 1. Aerovent; a division of Twin City Fan Companies, Ltd.
 2. Ammerman; Millennium Equipment.
 3. Greenheck Fan Corporation.
 4. Hartzell Fan Incorporated.
 5. Loren Cook Company.
 6. PennBarry.
 7. Twin City.
- B. Housing: Heavy-gage, removable, spun-aluminum, dome top and outlet baffle; venturi inlet cone.
- C. Fan Wheel: Aluminum hub and wheel with backward-inclined blades.
 1. Fan Guard: 1/2- by 1-inch mesh of galvanized steel in removable frame. Provide guard for inlet on units not connected to ductwork, where contact with fan wheel is within personal reach through access opening, or where falling objects and/or debris may enter fan.
- D. Direct-Drive Units: Motor mounted in airstream.
- E. Accessories:
 1. Disconnect Switch: Nonfusible type:
 - a. Thermal-overload protection; factory wired through an internal aluminum conduit.
 - 1) Mounted outside fan housing.
 2. Bird Screens: Removable, 1/2-inch mesh:
 - a. Aluminum wire.
 3. Wall Grille: Ring type for flush mounting.
 4. Dampers:
 - a. Counterbalanced, parallel-blade, backdraft dampers mounted in curb base; factory set to close when fan stops.

2.5 CEILING-MOUNTED VENTILATORS

- A. Manufacturers: Subject to compliance with requirements, provide products by one of the following:
 1. Greenheck Fan Corporation.
 2. Loren Cook Company.
 3. PennBarry.
 4. Twin City.
- B. Housing: Steel, lined with acoustical insulation.

- C. Fan Wheel: Centrifugal wheels directly mounted on motor shaft. Fan shrouds, motor, and fan wheel shall be removable for service.
- D. Grille: With flange on intake and thumbscrew attachment to fan housing.
 - 1. Painted steel.
- E. Electrical Requirements: Junction box for electrical connection on housing and receptacle for motor plug-in.

2.6 IN-LINE CENTRIFUGAL FANS

- A. Manufacturers: Subject to compliance with requirements, provide products by one of the following:
 - 1. Greenheck Fan Corporation.
 - 2. Hartzell Fan Incorporated.
 - 3. Loren Cook Company.
 - 4. PennBarry.
 - 5. Twin City.
- B. Housing: Split, spun aluminum with aluminum straightening vanes, inlet and outlet flanges, and support bracket adaptable to floor, side wall, or ceiling mounting.
- C. Direct-Drive Units: Motor mounted in airstream, factory wired to disconnect switch located on outside of fan housing with:
 - 1. Wheel, inlet cone.
- D. Belt-Driven Units: Motor mounted on adjustable base, with adjustable sheaves, enclosure around belts within fan housing, and lubricating tubes from fan bearings extended to outside of fan housing.
- E. Fan Wheels: Aluminum, airfoil blades welded to aluminum hub.
 - 1. Fan Guard: 1/2- by 1-inch mesh of galvanized steel in removable frame. Provide guard for inlet or outlet on units not connected to ductwork, where contact with fan wheel is within personal reach through access opening, or where falling objects and/or debris may enter fan.
- F. Accessories:
 - 1. Variable-Speed Controller: Solid-state control to reduce speed from 100 to less than 50 percent.
 - 2. Dampers:
 - a. Counterbalanced, parallel-blade, backdraft dampers mounted in curb base; factory set to close when fan stops.
 - 3. Motor and Drive Cover (Belt Guard): Epoxy-coated steel.
 - 4. Disconnect Switch: Nonfusible type:
 - a. Thermal-overload protection; factory wired through an internal aluminum conduit.
 - 1) Mounted inside fan housing.

2.7 PROPELLER FANS

- A. Manufacturers: Subject to compliance with requirements, provide products by one of the following:
 - 1. Aerovent; a division of Twin City Fan Companies, Ltd.
 - 2. Hartzell Fan Incorporated.
 - 3. Loren Cook Company.
 - 4. New York Blower Company (The).
 - 5. PennBarry.

- 6. Twin City.
- B. Housing: Galvanized-steel sheet with flanged edges and integral orifice ring with baked-enamel finish coat applied after assembly.
- C. Fan Wheel: Replaceable, extruded-aluminum, airfoil blades fastened to cast-aluminum hub; factory set pitch angle of blades.
- D. Fan Drive:
 - 1. Motor mounted in airstream
 - 2. Resiliently mounted to housing.
 - 3. Statically and dynamically balanced.
 - 4. Selected for continuous operation at maximum rated fan speed and motor horsepower, with final alignment and belt adjustment made after installation.
 - 5. Service Factor Based on Fan Motor Size: 1.4.
 - 6. Fan Shaft: Turned, ground, and polished steel; keyed to wheel hub.
 - 7. Shaft Bearings: Permanently lubricated, permanently sealed, self-aligning ball bearings.
 - a. Ball-Bearing Rating Life: ABMA 9, L_{10} of 100,000 hours.
 - 8. Fan Guard: 1/2- by 1-inch mesh of galvanized steel in removable frame. Provide guard for inlet or outlet on units not connected to ductwork, where contact with fan wheel is within personal reach through access opening, or where falling objects and/or debris may enter fan.
- E. Accessories:
 - 1. Motorized Damper: Parallel-blade dampers mounted in curb base with electric actuator; wired to close when fan stops.
 - 2. Disconnect Switch: Nonfusible type:
 - a. Thermal-overload protection; factory wired through an internal aluminum conduit.
 - 1) Mounted outside fan housing.

2.8 DRYER BOOSTER FANS (UL listed)

- A. Manufacturers: Subject to compliance with requirements, provide products by one of the following:
 - 1. American Aldes
 - 2. Fantech
 - 3. Reversomatic Manufacturing Ltd.
 - 4. Spruce Environmental Technologies Inc.
 - 5. Tjernlund Products Inc.
- B. Housing:
 - 1. G90 galvanized steel or thermoplastic.
- C. Wheel:
 - 1. Backward incline
 - 2. Self Cleaning.
- D. Positive Pressure Switch:
 - 1. Positive pressure switch to start fan when dryer starts.
 - 2. Switch pressure set to 0.05 inches of water column
 - 3. Integrated timer in switch to maintain fan performance until drying cycle is complete.
- E. Motor:
 - 1. 120 volt
 - 2. Permanently sealed self lubricating
 - 3. Automatic reset thermal overload protection
 - 4. Acceptable for continuous duty.

2.9 MOTORS

- A. Comply with NEMA designation, temperature rating, service factor, enclosure type, and efficiency requirements for motors specified in Section 230513 "Common Motor Requirements for HVAC Equipment."
 - 1. Motor Sizes: Minimum size as indicated. If not indicated, large enough so driven load will not require motor to operate in service factor range above 1.0.
 - 2. Controllers, Electrical Devices, and Wiring: Comply with requirements for electrical devices and connections specified in Division 26 Sections.
- B. Enclosure Type: Totally enclosed;
 - 1. Fan cooled

2.10 FACTORY FINISH

- A. Metal Parts: All assembly parts shall be protected from rust and corrosion.
 - 1. Stainless steel, aluminum, and other non-corroding materials require no protective finish.
 - 2. Non-galvanized sheet metal parts shall be prime coated or powder coated before final assembly.
 - 3. Prime coated parts shall receive baked enamel finish coat after assembly.

2.11 SOURCE QUALITY CONTROL

- A. Certify sound-power level ratings according to AMCA 301, "Methods for Calculating Fan Sound Ratings from Laboratory Test Data." Factory test fans according to AMCA 300, "Reverberant Room Method for Sound Testing of Fans." Label fans with the AMCA-Certified Ratings Seal.
- B. Certify fan performance ratings, including flow rate, pressure, power, air density, speed of rotation, and efficiency by factory tests according to AMCA 210, "Laboratory Methods of Testing Fans for Aerodynamic Performance Rating." Label fans with the AMCA-Certified Ratings Seal.

PART 3 - EXECUTION

3.1 EXAMINATION

- A. Examine areas and conditions for compliance with requirements of installation tolerances and other conditions affecting performance of the power ventilators. Do not proceed with installation until unsatisfactory conditions have been corrected.

3.2 PROJECT CONDITIONS

- A. Field Measurements: Verify dimensions by field measurements. Verify clearances.
- B. Do not operate fans until ductwork is clean, filters are in place, bearings are lubricated, and fans have been commissioned.

3.3 INSTALLATION

- A. Install power ventilators level and plumb according to manufacturer's written instructions.
- B. Base Mounted Equipment:

1. Install power ventilators on cast-in-place concrete equipment base(s). Comply with requirements for equipment bases and foundations specified in:
 - a. Division 33 "Cast-in-Place Concrete."
- C. Secure roof-mounted fans to roof curbs with cadmium-plated hardware. See Section 077200 "Roof Accessories" for installation of roof curbs.
- D. Ceiling Units: Suspend units from structure; use steel wire or metal straps.
- E. Support Steel: Support suspended units from structure using threaded steel as specified in Division 23 "Vibration and Seismic Controls for HVAC."
- F. Label units according to requirements specified in Division 23 "Identification for HVAC Piping and Equipment."
- G. Install power ventilators with factory recommended and code required clearances for service and maintenance.
- H. Install dryer booster fan per manufacturer's instructions.

3.4 CONNECTIONS

- A. Duct installation and connection requirements are specified in other Division 23 Sections. Drawings indicate general arrangement of ducts and duct accessories. Make final duct connections with flexible connectors. Flexible connectors are specified in Section 233300 "Air Duct Accessories."
- B. Install ducts adjacent to power ventilators to allow service and maintenance.
- C. Ground equipment according to Division 26 "Grounding and Bonding for Electrical Systems."
 1. Tighten electrical connectors and terminals, including grounding connections, according to manufacturer's published torque-tightening values. Where manufacturer's torque values are not indicated, use those specified in UL 486A and UL 486B.
- D. Connect wiring according to Division 26 "Low-Voltage Electrical Power Conductors and Cables."
 1. Tighten electrical connectors and terminals, including grounding connections, according to manufacturer's published torque-tightening values. Where manufacturer's torque values are not indicated, use those specified in UL 486A and UL 486B.

3.5 FIELD QUALITY CONTROL

- A. Perform tests and inspections.
 1. Manufacturer's Field Service: Engage a factory-authorized service representative to inspect components, assemblies, and equipment installations, including connections, and to assist in testing.

3.6 ADJUSTING

- A. Adjust damper linkages for proper damper operation.
- B. Adjust belt tension.
- C. Comply with requirements in Division 23 "Testing, Adjusting, and Balancing for HVAC" for testing, adjusting, and balancing procedures.

- D. Replace fan and motor pulleys as required to achieve design airflow.
- E. Lubricate bearings.

3.7 CLEANING

- A. After completing installation, inspect exposed finish. Remove burrs, dirt, and construction debris, and repair damaged finishes including chips, scratches, and abrasions.
- B. Clean fan interiors to remove foreign material and construction debris. Vacuum clean fan wheel and cabinet.

3.8 DEMONSTRATION

- A. Train Owner's maintenance personnel on procedures and schedules related to startup and shutdown, troubleshooting, servicing, and preventive maintenance.
- B. Review data in the operation and maintenance manuals. Refer to Division 1 Section "Contract Closeout."
- C. Schedule training with Owner, through Architect, with at least 7 days' advance notice.
- D. Demonstrate operation of power ventilators. Conduct walking tour of the Project. Briefly identify location and describe function, operation, and maintenance of each power ventilator.

END OF SECTION 23 3423

SECTION 23 3600

AIR TERMINAL UNITS

PART 1 - GENERAL

1.1 RELATED DOCUMENTS

- A. Drawings and general provisions of the Contract, including General and Supplementary Conditions and Division 01 Specification Sections, apply to this Section.

1.2 SUMMARY

- A. Section Includes:
 - 1. Shutoff, single-duct air terminal units.

1.3 ACTION SUBMITTALS

- A. Product Data: For each type of the following products, including rated capacities, furnished specialties, sound-power ratings, and accessories.
 - 1. Air terminal units.
 - 2. Liners and adhesives.
 - 3. Sealants and gaskets.
 - 4. Seismic-restraint devices.
- B. LEED Submittals:
 - 1. Product Data for Prerequisite IEQ 1: Documentation indicating that units comply with ASHRAE 62.1, Section 5 - "Systems and Equipment."
- C. Shop Drawings: For air terminal units. Include plans, elevations, sections, details, and attachments to other work.
 - 1. Detail equipment assemblies and indicate dimensions, weights, loads, required clearances, method of field assembly, components, and location and size of each field connection.
 - 2. Wiring Diagrams:
 - a. For power, signal, and control wiring.
 - b. Differentiate between manufacturer-installed and field-installed wiring.
 - 3. Hangers and supports, including methods for duct and building attachment, seismic restraints, and vibration isolation.
- D. Delegated-Design Submittal:
 - 1. Materials, fabrication, assembly, and spacing of hangers and supports.
 - 2. Design Calculations: Calculations, including analysis data signed and sealed by the qualified professional engineer responsible for their preparation for selecting hangers and supports.
- E. Airborne noise data for terminal units serving Patient Rooms:

1. Declared discharge and radiated sound power levels by octave band covering a minimum range of 63 to 4000 hertz
2. Method of determining declared sound power levels.

1.4 INFORMATIONAL SUBMITTALS

- A. Coordination Drawings: Reflected ceiling plans, drawn to scale, on which the following items are shown and coordinated with each other, using input from Installers of the items involved:
 1. Ceiling suspension assembly members.
 2. Size and location of initial access modules for acoustic tile.
 3. Ceiling-mounted items including lighting fixtures, diffusers, grilles, speakers, sprinklers, access panels, and special moldings.
- B. Field quality-control reports.

1.5 PERFORMANCE REQUIREMENTS

- A. Seismic Performance: Air terminal units shall withstand the effects of earthquake motions determined according to SEI/ASCE 7.
 1. The term "withstand" means "the unit will remain in place without separation of any parts from the device when subjected to the seismic forces specified and the unit will be fully operational after the seismic event."

1.6 CLOSEOUT SUBMITTALS

- A. Operation and Maintenance Data: For air terminal units to include in emergency, operation, and maintenance manuals. In addition to items specified in Section 017823 "Operation and Maintenance Data," include the following:
 1. Instructions for resetting minimum and maximum air volumes.
 2. Instructions for adjusting software set points.

1.7 MAINTENANCE MATERIAL SUBMITTALS

- A. Furnish extra materials that match products installed and that are packaged with protective covering for storage and identified with labels describing contents.
 1. Fan-Powered-Unit Filters: Furnish one spare filter for each filter installed.

1.8 QUALITY ASSURANCE

- A. ASHRAE Compliance: Applicable requirements in ASHRAE 62.1, Section 5 - "Systems and Equipment" and Section 7 - "Construction and System Start-Up."
- B. Product Options: Drawings and schedules indicate requirements of air terminals and are based on specific systems indicated. Other manufacturers' systems with equal performance characteristics may be considered. Refer to Division 1 Section "Substitutions."
- C. Listing and Labeling: Provide electrically operated air terminals specified in this Section that are listed and labeled.
 1. The Terms "Listed" and "Labeled": As defined in NFPA 70, Article 100.

- D. NFPA Compliance: Install air terminals according to NFPA 90A, "Standard for the Installation of Air Conditioning and Ventilating Systems."
- E. Comply with NFPA 70 for electrical components and installation.
- F. Airborne Noise:
 - 1. Comply with ANSI / AHRI 880 - Performance Rating of Air Terminals

PART 2 - PRODUCTS

2.1 PERFORMANCE REQUIREMENTS

- A. Structural Performance: Hangers and supports shall withstand the effects of gravity loads and stresses within limits and under conditions described in SMACNA's "HVAC Duct Construction Standards - Metal and Flexible".
- B. Airborne Noise:
 - 1. Maximum sound power levels by octave band in decibels referenced to on picowatt:

AHU	Source	Sound Power Level by Octave Band (Hz), dBL (re 10 ⁻¹² W)						
		63	125	250	500	1000	2000	4000
VAV Box serving Patient Rooms	Discharge	71	69	69	62	54	50	47
	Radiated	60	60	58	50	40	36	33

2.2 SYSTEM DESCRIPTION

- A. Electrical Components, Devices, and Accessories: Listed and labeled as defined in NFPA 70, by a qualified testing agency, and marked for intended location and application.

2.3 SHUTOFF, SINGLE-DUCT AIR TERMINAL UNITS

- A. Manufacturers: Subject to compliance with requirements, provide products by one of the following:
 - 1. Anemostat Products; a Mestek Company.
 - 2. Carnes.
 - 3. Environmental Technologies, Inc.
 - 4. Krueger.
 - 5. METALAIRE, Inc.
 - 6. Nailor Industries Inc.
 - 7. Price Industries.
 - 8. Titus.
 - 9. Trox USA Inc.; a subsidiary of the TROX GROUP.
 - 10. Tuttle & Bailey.
 - 11. Warren Technology.
- B. Configuration: Volume-damper assembly inside unit casing with control components inside a protective metal shroud.

- C. Casing: 0.034-inch steel, single wall.
 - 1. Casing Lining: Adhesive attached, coated, fibrous-glass duct liner complying with ASTM C 1071, and having a maximum flame-spread index of 25 and a maximum smoke-developed index of 50, for both insulation and adhesive, when tested according to ASTM E 84.
 - a. Lining thickness:
 - 1) 1/2-inch-
 - b. Cover liner with nonporous foil.
 - 2. Air Inlet: Round stub connection or S-slip and drive connections for duct attachment.
 - 3. Air Outlet: S-slip and drive connections.
 - 4. Air Outlet: S-slip and drive connections size matching inlet size.
 - 5. Access: Removable panels for access to parts requiring service, adjustment, or maintenance; with airtight gasket.
 - 6. (LEED) Airstream Surfaces: Surfaces in contact with the airstream shall comply with requirements in ASHRAE 62.1.
 - 7. Access Door: Access door upstream of the reheat coil.
- D. Volume Damper: Galvanized steel with peripheral gasket and self-lubricating bearings.
 - 1. Maximum Damper Leakage:
 - a. ARI 880 rated, 3 percent of nominal airflow at 3-inch wg inlet static pressure.
 - 2. Damper Position:
 - a. Normally open.
- E. Hydronic Coils: Copper tube, with mechanically bonded aluminum fins spaced no closer than 0.1 inch, and rated for a minimum working pressure of 200 psig and a maximum entering-water temperature of 220 deg F. Include manual air vent and drain valve.
- F. Direct Digital Controls: See Section 230900 "Instrumentation and Controls for HVAC".

2.4 HANGERS AND SUPPORTS

- A. Hanger Rods for Noncorrosive Environments: Cadmium-plated steel rods and nuts.
- B. Hanger Rods for Corrosive Environments: Electrogalvanized, all-thread rods or galvanized rods with threads painted with zinc-chromate primer after installation.
- C. Steel Cables: Galvanized steel complying with ASTM A 603.
- D. Steel Cable End Connections: Cadmium-plated steel assemblies with brackets, swivel, and bolts designed for duct hanger service; with an automatic-locking and clamping device.
- E. Air Terminal Unit Attachments: Sheet metal screws, blind rivets, or self-tapping metal screws; compatible with duct materials.
- F. Trapeze and Riser Supports: Steel shapes and plates for units with steel casings; aluminum for units with aluminum casings.

2.5 SOURCE QUALITY CONTROL

- A. Factory Tests: Test assembled air terminal units according to ARI 880.
 - 1. Label each air terminal unit with plan number, nominal airflow, maximum and minimum factory-set airflows, and ARI certification seal.

PART 3 - EXECUTION

3.1 INSTALLATION

- A. Install air terminal units according to NFPA 90A, "Standard for the Installation of Air Conditioning and Ventilating Systems."
- B. Install air terminal units level and plumb. Maintain sufficient clearance for normal service and maintenance.
- C. Install wall-mounted thermostats.
- D. Install discharge air temperature sensors at the outlet of each Air Terminal Unit.
- E. Connect ductwork to air terminals according to Division 23 ductwork Sections.
- F. Comply with SEI/ASCE 7 and with requirements for seismic-restraint devices in Section 230548 "Vibration and Seismic Controls for HVAC."
- G. For Diffuser Type Air Terminal Units, provide and install all necessary control wiring and control voltage transformer. See drawings AND schedules for additional information.

3.2 HANGER AND SUPPORT INSTALLATION

- A. Comply with SMACNA's "HVAC Duct Construction Standards - Metal and Flexible," Chapter 5, "Hangers and Supports."
- B. Building Attachments: Concrete inserts, powder-actuated fasteners, or structural-steel fasteners appropriate for construction materials to which hangers are being attached.
 - 1. Where practical, install concrete inserts before placing concrete.
 - 2. Install powder-actuated concrete fasteners after concrete is placed and completely cured.
 - 3. Use powder-actuated concrete fasteners for standard-weight aggregate concretes and for slabs more than 4 inches thick.
 - 4. Do not use powder-actuated concrete fasteners for lightweight-aggregate concretes and for slabs less than 4 inches thick.
 - 5. Do not use powder-actuated concrete fasteners for seismic restraints.
- C. Hangers Exposed to View: Threaded rod and angle or channel supports.
- D. Install upper attachments to structures. Select and size upper attachments with pull-out, tension, and shear capacities appropriate for supported loads and building materials where used.

3.3 CONNECTIONS

- A. Install piping adjacent to air terminal unit to allow service and maintenance.
- B. Hot-Water Piping: In addition to requirements in Section 232113 "Hydronic Piping" and Section 232116 "Hydronic Piping Specialties," connect heating coils to supply with shutoff valve, strainer, control valve, and union or flange; and to return with balancing valve and union or flange.
- C. Connect ducts to air terminal units according to Section 233113 "Metal Ducts."

- D. Make connections to air terminal units with flexible connectors complying with requirements in Section 233300 "Air Duct Accessories."
- E. Electrically ground all equipment:
 - 1. Tighten electrical connectors and terminals according to manufacturer's published torque-tightening values. Where manufacturer's torque values are not indicated, use those specified in UL 486A and UL 486B.

3.4 IDENTIFICATION

- A. Label each air terminal unit with plan number, nominal airflow, and maximum and minimum factory-set airflows. Comply with requirements in Section 230553 "Identification for HVAC Piping and Equipment" for equipment labels and warning signs and labels.

3.5 FIELD QUALITY CONTROL

- A. Manufacturer's Field Service: Engage a factory-authorized service representative to inspect, test, and adjust components, assemblies, and equipment installations, including connections.
- B. Perform tests and inspections.
 - 1. Manufacturer's Field Service: Engage a factory-authorized service representative to inspect components, assemblies, and equipment installations, including connections, and to assist in testing.
- C. Tests and Inspections:
 - 1. After installing air terminal units and after electrical circuitry has been energized, test for compliance with requirements.
 - 2. Leak Test: After installation, fill water coils and test for leaks. Repair leaks and retest until no leaks exist.
 - 3. Operational Test: After electrical circuitry has been energized, start units to confirm proper motor rotation and unit operation.
 - 4. Test and adjust controls and safeties. Replace damaged and malfunctioning controls and equipment.
- D. Air terminal unit will be considered defective if it does not pass tests and inspections.
- E. Prepare test and inspection reports.
- F. Cleaning:
 - 1. After completing system installation, including outlet fittings and devices, inspect exposed finish. Remove burrs, dirt, and construction debris, and repair damaged finishes.

3.6 STARTUP SERVICE

- A. Engage a factory-authorized service representative to perform startup service.
 - 1. Complete installation and startup checks according to:
 - a. Manufacturer's written instructions.
 - b. Construction documents.
 - 2. Verify that inlet duct connections are as recommended by air terminal unit manufacturer to achieve proper performance.
 - 3. Verify that controls and control enclosure are accessible.
 - 4. Verify that control connections are complete.
 - 5. Verify that nameplate and identification tag are visible.

6. Verify that controls respond to inputs as specified.

3.7 DEMONSTRATION

- A. Engage a factory-authorized service representative to train Owner's maintenance personnel to adjust, operate, and maintain air terminal units:
 1. Train Owner's maintenance personnel on procedures and schedules related to startup and shutdown, troubleshooting, servicing, and preventive maintenance.
 2. Review data in the maintenance manuals. Refer to Division 1 Section "Contract Closeout."
 3. Review data in the maintenance manuals. Refer to Division 1 Section "Operation and Maintenance Data."
 4. Schedule training with Owner, through Architect, with at least 7 days' advance notice.

END OF SECTION 23 3600

THIS PAGE LEFT BLANK INTENTIONALLY

SECTION 23 3713

DIFFUSERS, REGISTERS, AND GRILLES

PART 1 - GENERAL

1.1 RELATED DOCUMENTS

- A. Drawings and general provisions of the Contract, including General and Supplementary Conditions and Division 01 Specification Sections, apply to this Section.

1.2 SUMMARY

- A. This section includes ceiling- and wall-mounted diffusers, registers, and grilles.
- B. Related Sections:
 - 1. Section 233714 "Fixed Louvers" for fixed and louvers and wall vents, whether or not they are connected to ducts.
 - 2. Section 233300 "Air Duct Accessories" for fire and smoke dampers and volume-control dampers not integral to diffusers, registers, and grilles.
 - 3. Section 230594 "General Testing, Adjusting and Balancing" for balancing diffusers, registers, and grilles.

1.3 ACTION SUBMITTALS

- A. Product Data: For each type of product indicated, include the following:
 - 1. Data Sheet: Indicate materials of construction, finish, and mounting details; and performance data including throw and drop, static-pressure drop, and noise ratings.
 - 2. Diffuser, Register, and Grille Schedule: Indicate drawing designation, room location, quantity, model number, size, and accessories furnished.

1.4 INFORMATIONAL SUBMITTALS

- A. Coordination Drawings: Reflected ceiling plans, drawn to scale, on which the following items are shown and coordinated with each other, using input from Installers of the items involved:
 - 1. Ceiling suspension assembly members.
 - 2. Method of attaching hangers to building structure.
 - 3. Size and location of initial access modules for acoustical tile.
 - 4. Ceiling-mounted items including lighting fixtures, diffusers, grilles, speakers, sprinklers, access panels, and special moldings.
 - 5. Duct access panels.
- B. Source quality-control reports.

1.5 QUALITY ASSURANCE

- A. Product Options: Drawings and schedules indicate specific requirements of diffusers, registers, and grilles and are based on the specific requirements of the systems indicated.

- B. NFPA Compliance: Install diffusers, registers, and grilles according to NFPA 90A, "Standard for the Installation of Air-Conditioning and Ventilating Systems."
- C. Airborne Noise:
 - 1. Comply with ANSI / AHRI 880 - Performance Rating of Air Terminals

PART 2 - PRODUCTS

2.1 MANUFACTURERS

- A. Manufacturers: Subject to compliance with requirements, provide products by one of the following:
 - 1. Air Factors
 - 2. Carnes.
 - 3. Kruegar.
 - 4. METALAIRE, Inc.
 - 5. Nailor Industries Inc.
 - 6. Price Industries.
 - 7. Titus.
 - 8. Tuttle & Bailey.
 - 9. AJ Manufacturing

2.2 REGISTERS, GRILLES, & DIFFUSERS

- A. General: The frames for all registers, grilles, and diffusers shall match type of ceiling where they are to be installed. Special frames shall be provided for narrow T-bar ceilings. Refer to reflected ceiling plan and other specification divisions for ceiling type. See drawings AND schedules for additional information.

2.3 SOURCE QUALITY CONTROL

- A. Verification of Performance: Rate diffusers, registers, and grilles according to ASHRAE 70, "Method of Testing for Rating the Performance of Air Outlets and Inlets."

PART 3 - EXECUTION

3.1 EXAMINATION

- A. Examine areas where diffusers, registers, and grilles are to be installed for compliance with requirements for installation tolerances and other conditions affecting performance of equipment.
- B. Proceed with installation only after unsatisfactory conditions have been corrected.

3.2 INSTALLATION

- A. Install diffusers, registers, and grilles level and plumb, according to manufacturer's written instructions, coordination drawings, original design, and referenced standards.

- B. Ceiling-Mounted Outlets and Inlets: Drawings indicate general arrangement of ducts, fittings, and accessories. Air outlet and inlet locations have been indicated to achieve design requirements for air volume, noise criteria, airflow pattern, throw, and pressure drop. Make final locations where indicated, as much as practical. For units installed in lay-in ceiling panels, locate units in the center of panel. Where architectural features or other items conflict with installation, notify Architect for a determination of final location.
- C. Install diffusers, registers, and grilles with airtight connections to ducts and to allow service and maintenance of dampers, air extractors, and fire dampers.

3.3 ADJUSTING

- A. After installation, adjust diffusers, registers, and grilles to air patterns indicated, or as directed, before starting air balancing.

3.4 CLEANING

- A. After installation of diffusers, registers, and grilles, inspect exposed finish. Clean exposed surfaces to remove burrs, dirt, and smudges. Replace diffusers, registers, and grilles that have damaged finishes.

END OF SECTION 23 3713

THIS PAGE LEFT BLANK INTENTIONALLY

DIVISION 26 – ELECTRICAL

Section 26 0519	Low-Voltage Electrical Power Conductors and Cables
Section 26 0526	Grounding and Bonding for Electrical Systems
Section 26 0529	Hangers and Supports for Electrical Systems
Section 26 0533	Raceways and Boxes for Electrical Systems
Section 26 0548	Vibration and Seismic Controls for Electrical Systems
Section 26 0553	Identification for Electrical Systems
Section 26 0923	Lighting Control Devices
Section 26 2726	Wiring Devices
Section 26 5119	LED Interior Lighting

THIS PAGE LEFT BLANK INTENTIONALLY

SECTION 26 0519
LOW-VOLTAGE ELECTRICAL POWER CONDUCTORS AND CABLES

PART 1 - GENERAL

1.1 RELATED DOCUMENTS

- A. Drawings and general provisions of the Contract, including General and Supplementary Conditions and Division 01 Specification Sections, apply to this Section.

1.2 SUMMARY

- A. Section Includes:
 - 1. Building wires and cables rated 600 V and less.
 - 2. Connectors, splices, and terminations rated 600 V and less.
- B. Related Requirements:
 - 1. Section 271500 "Communications Horizontal Cabling" for cabling used for voice and data circuits.

1.3 ACTION SUBMITTALS

- A. Product Data: For each type of product.

1.4 INFORMATIONAL SUBMITTALS

- A. Qualification Data: For testing agency.
- B. Field quality-control reports.

1.5 QUALITY ASSURANCE

- A. Testing Agency Qualifications: Member company of NETA or an NRTL.
 - 1. Testing Agency's Field Supervisor: Certified by NETA to supervise on-site testing.

PART 2 - PRODUCTS

2.1 CONDUCTORS AND CABLES

- A. Manufacturers: Subject to compliance with requirements, available manufacturers offering products that may be incorporated into the Work include, but are not limited to, the following:
 - 1. Alcan Products Corporation; Alcan Cable Division.
 - 2. Alpha Wire.
 - 3. Belden Inc.
 - 4. Encore Wire Corporation.
 - 5. General Cable Technologies Corporation.
 - 6. Southwire Incorporated.
- B. Copper Conductors: Comply with NEMA WC 70/ICEA S-95-658.
- C. Conductor Insulation: Comply with NEMA WC 70/ICEA S-95-658 for Type THHN-2-THWN-2.

2.2 CONNECTORS AND SPLICES

- A. Manufacturers: Subject to compliance with requirements, available manufacturers offering products that may be incorporated into the Work include, but are not limited to, the following:
 - 1. AFC Cable Systems, Inc.
 - 2. Gardner Bender.
 - 3. Hubbell Power Systems, Inc.
 - 4. Ideal Industries, Inc.
 - 5. IlSCO; a branch of Bardes Corporation.
 - 6. NSi Industries LLC.
 - 7. O-Z/Gedney; a brand of the EGS Electrical Group.

8. 3M; Electrical Markets Division.
9. Tyco Electronics.

- B. Description: Factory-fabricated connectors and splices of size, ampacity rating, material, type, and class for application and service indicated.

2.3 SYSTEM DESCRIPTION

- A. Electrical Components, Devices, and Accessories: Listed and labeled as defined in NFPA 70, by a qualified testing agency, and marked for intended location and application.
- B. Comply with NFPA 70.

PART 3 - EXECUTION

- A. Feeders:
1. Copper Stranded
 2. AA-8000 Aluminum alloy compact stranded conductor for sizes 1/0 AWG-750 kcmil. THHN, THWN-2 OR XHHW-2 Insulation depending on application
 - a. Allowed to use for the following:
 - 1) Service entrance conductors
 - 2) Feeders supplying switchboards and panelboards
 - b. Not allowed to use for the following:
 - 1) Branch circuit wiring
 - 2) Motor feeders
 - 3) Mechanical Equipment Feeders
 - 4) Imaging Equipment Feeders
 - 5) Feeders for equipment not labeled for use with aluminum conductors.
- B. Branch Circuits: Copper. Solid or stranded for No. 10 AWG and smaller; stranded for No. 8 AWG and larger, except VFC cable, which shall be extra flexible stranded.
- C. Fire Alarm Circuits:
1. THWN-2 conductors in raceway for fire alarm power and horn/strobe indicating circuits.
 2. Power limited signaling circuit cable in raceway for initiating loops
- D. Class 1 Control Circuits: Type THWN-2, in raceway.
- E. Class 2 Control Circuits: Type THWN-2, in raceway.

3.2 CONDUCTOR INSULATION AND MULTICONDUCTOR CABLE APPLICATIONS AND WIRING METHODS

- A. Branch Circuits Concealed in Wall and Partitions: Type THHN/THWN-2, single conductors in raceway or Armored cable, Type AC with restrictions listed below:
1. Type AC cable may be used for normal and equipment system single branch circuits concealed in walls, and partitions in lengths between outlet boxes 30' or less and not as homeruns or wiring between pullboxes or junction boxes. May be used to connect circuits from junction box above accessible ceilings to first outlet box that is concealed in wall or partition. Junction boxes used for this purpose must be installed directly adjacent to the location where the cable enters the wall.
 2. Type AC cable may not be used for wiring of emergency system (life safety and critical branches).
 3. Patient Care Area branch circuits: Branch circuit wiring in all patient care areas shall comply with NEC 517.13 (a). Do not use non-metallic conduits or raceways for branch circuits serving areas other than mechanical and electrical rooms.

- B. Branch Circuits Concealed in Concrete, below Slabs-on-Grade, and Underground: Type THHN-2-THWN-2, single conductors in raceway.
- C. Every Branch circuit must have a dedicated neutral.
- D. Cord Drops and Portable Appliance Connections: Type SO, hard service cord with stainless-steel, wire-mesh, strain relief device at terminations to suit application.

3.3 INSTALLATION OF CONDUCTORS AND CABLES

- A. Conceal cables in finished walls, ceilings, and floors unless otherwise indicated.
- B. Complete raceway installation between conductor and cable termination points according to Section 260533 "Raceways and Boxes for Electrical Systems" prior to pulling conductors and cables.
- C. Use manufacturer-approved pulling compound or lubricant where necessary; compound used must not deteriorate conductor or insulation. Do not exceed manufacturer's recommended maximum pulling tensions and sidewall pressure values.
- D. Use pulling means, including fish tape, cable, rope, and basket-weave wire/cable grips, that will not damage cables or raceway.
- E. Install exposed cables parallel and perpendicular to surfaces of exposed structural members, and follow surface contours where possible.
- F. Support cables according to Section 260529 "Hangers and Supports for Electrical Systems."
- G. Complete cable tray systems installation according to Section 260536 "Cable Trays for Electrical Systems" prior to installing conductors and cables.
- H. Fire alarm cables to be installed in EMT raceway

3.4 CONNECTIONS

- A. Tighten electrical connectors and terminals according to manufacturer's published torque-tightening values. If manufacturer's torque values are not indicated, use those specified in UL 486A-486B.
- B. Make splices, terminations, and taps that are compatible with conductor material and that possess equivalent or better mechanical strength and insulation ratings than unspliced conductors.
 - 1. Use oxide inhibitor in each splice, termination, and tap for aluminum conductors.
- C. Wiring at Outlets: Install conductor at each outlet, with at least 6 inches (150 mm) of slack.

3.5 IDENTIFICATION

- A. Identify and color-code conductors and cables according to Section 260553 "Identification for Electrical Systems."
- B. Identify each spare conductor at each end with identity number and location of other end of conductor, and identify as spare conductor.

3.6 SLEEVE AND SLEEVE-SEAL INSTALLATION FOR ELECTRICAL PENETRATIONS

- A. Install sleeves and sleeve seals at penetrations of exterior floor and wall assemblies. Comply with requirements in Section 260544 "Sleeves and Sleeve Seals for Electrical Raceways and Cabling."

3.7 FIRESTOPPING

- A. Apply firestopping to electrical penetrations of fire-rated floor and wall assemblies to restore original fire-resistance rating of assembly according to Section 078413 "Penetration Firestopping."

3.8 FIELD QUALITY CONTROL

- A. Perform the following tests and inspections:
 - 1. After installing conductors and cables and before electrical circuitry has been energized, test service entrance and feeder conductors and conductors feeding all imaging equipment for compliance with requirements.
 - 2. Infrared Scanning: After Substantial Completion, but not more than 60 days after Final Acceptance, perform an infrared scan of each splice in conductors No. 3 AWG and larger. Remove box and equipment covers so splices are accessible to portable scanner. Correct deficiencies determined during the scan.
 - a. Follow-up Infrared Scanning: Perform an additional follow-up infrared scan of each splice 11 months after date of Substantial Completion.
 - b. Instrument: Use an infrared scanning device designed to measure temperature or to detect significant deviations from normal values. Provide calibration record for device.
 - c. Record of Infrared Scanning: Prepare a certified report that identifies splices checked and that describes scanning results. Include notation of deficiencies detected, remedial action taken, and observations after remedial action.
- B. Test and Inspection Reports: Prepare a written report to record the following:
 - 1. Procedures used.
 - 2. Results that comply with requirements.
 - 3. Results that do not comply with requirements and corrective action taken to achieve compliance with requirements.
- C. Cables will be considered defective if they do not pass tests and inspections.

END OF SECTION

SECTION 260526

GROUNDING AND BONDING FOR ELECTRICAL SYSTEMS

PART 1 - GENERAL

1.1 RELATED DOCUMENTS

- A. Drawings and general provisions of the Contract, including General and Supplementary Conditions and Division 01 Specification Sections, apply to this Section.

1.2 SUMMARY

- A. Section Includes: Grounding systems and equipment.
- B. Section includes grounding systems and equipment, plus the following special applications:
 - 1. Overhead-line grounding.
 - 2. Underground distribution grounding.
 - 3. Ground bonding common with lightning protection system.

1.3 ACTION SUBMITTALS

- A. Product Data: For each type of product indicated.

1.4 INFORMATIONAL SUBMITTALS

- A. Informational Submittals: Plans showing dimensioned as-built locations of grounding features specified in "Field Quality Control" Article, including the following:
 - 1. Test wells.
 - 2. Ground rods.
 - 3. Ground rings.
 - 4. Grounding arrangements and connections for separately derived systems.
 - 5. Grounding for sensitive electronic equipment.
- B. Qualification Data: For qualified testing agency and testing agency's field supervisor.
- C. Field quality-control reports.

1.5 CLOSEOUT SUBMITTALS

- A. Operation and Maintenance Data: For grounding to include in emergency, operation, and maintenance manuals. In addition to items specified in Section 017823 "Operation and Maintenance Data," include the following:
 - 1. Instructions for periodic testing and inspection of grounding features at test wells, ground rings, and grounding connections for separately derived systems based on NETA MTS.
 - a. Tests shall determine if ground-resistance or impedance values remain within specified maximums, and instructions shall recommend corrective action if values do not.
 - b. Include recommended testing intervals.

1.6 QUALITY ASSURANCE

- A. Testing Agency Qualifications: Member company of NETA or an NRTL.
 - 1. Testing Agency's Field Supervisor: Currently certified by NETA to supervise on-site testing.
- B. Electrical Components, Devices, and Accessories: Listed and labeled as defined in NFPA 70, by a qualified testing agency, and marked for intended location and application.
- C. Comply with UL 467 for grounding and bonding materials and equipment.

PART 2 - PRODUCTS

2.1 CONDUCTORS

- A. Insulated Conductors: Copper or tinned-copper wire or cable insulated for 600 V unless otherwise required by applicable Code or authorities having jurisdiction.
- B. Bare Copper Conductors:
 - 1. Solid Conductors: ASTM B 3.
 - 2. Stranded Conductors: ASTM B 8.
 - 3. Tinned Conductors: ASTM B 33.
 - 4. Bonding Cable: 28 kcmil, 14 strands of No. 17 AWG conductor, 1/4 inch (6 mm) in diameter.
 - 5. Bonding Conductor: No. 4 or No. 6 AWG, stranded conductor.
 - 6. Bonding Jumper: Copper tape, braided conductors terminated with copper ferrules; 1-5/8 inches (41 mm) wide and 1/16 inch (1.6 mm) thick.
 - 7. Tinned Bonding Jumper: Tinned-copper tape, braided conductors terminated with copper ferrules; 1-5/8 inches (41 mm) wide and 1/16 inch (1.6 mm) thick.
- C. Bare Grounding Conductor and Conductor Protector for Wood Poles:
 - 1. No. 4 AWG minimum, soft-drawn copper.
 - 2. Conductor Protector: Half-round PVC or wood molding; if wood, use pressure-treated fir, cypress, or cedar.
- D. Grounding Bus: Predrilled rectangular bars of annealed copper, 1/4 by 4 inches (6.3 by 100 mm) in cross section, with 9/32-inch (7.14-mm) holes spaced 1-1/8 inches (28 mm) apart. Stand-off insulators for mounting shall comply with UL 891 for use in switchboards, 600 V. Lexan or PVC, impulse tested at 5000 V.

2.2 CONNECTORS

- A. Listed and labeled by an NRTL acceptable to authorities having jurisdiction for applications in which used and for specific types, sizes, and combinations of conductors and other items connected.
- B. Bolted Connectors for Conductors and Pipes: Copper or copper alloy, pressure type with at least two bolts.
 - 1. Pipe Connectors: Clamp type, sized for pipe.
- C. Welded Connectors: Exothermic-welding kits of types recommended by kit manufacturer for materials being joined and installation conditions.
- D. Bus-bar Connectors: Mechanical type, cast silicon bronze, solderless-type wire terminals, and long-barrel, two-bolt connection to ground bus bar.

2.3 GROUNDING ELECTRODES

- A. Ground Rods: Copper-clad steel; 3/4 inch by 10 feet (19 mm by 3 m) in diameter.

PART 3 - EXECUTION

3.1 APPLICATIONS

- A. Conductors: Install solid conductor for No. 8 AWG and smaller, and stranded conductors for No. 6 AWG and larger unless otherwise indicated.
- B. Underground Grounding Conductors: Install bare tinned-copper conductor, No. 4/0 AWG minimum.
 - 1. Bury at least 24 inches (600 mm) below grade.
- C. Isolated Grounding Conductors: Green-colored insulation with continuous yellow stripe. On feeders with isolated ground, identify grounding conductor where visible to normal inspection, with alternating bands of green and yellow tape, with at least three bands of green and two bands of yellow.

- D. Grounding Bus: Install in electrical and telephone equipment rooms, in rooms housing service equipment, and elsewhere as indicated.
 - 1. Install bus on insulated spacers 2 inches (50 mm) minimum from wall, 6 inches (150 mm) above finished floor unless otherwise indicated.
 - 2. Where indicated on both sides of doorways, route bus up to top of door frame, across top of doorway, and down to specified height above floor; connect to horizontal bus.
- E. Conductor Terminations and Connections:
 - 1. Pipe and Equipment Grounding Conductor Terminations: Bolted connectors.
 - 2. Underground Connections: Welded connectors except at test wells and as otherwise indicated.
 - 3. Connections to Ground Rods at Test Wells: Bolted connectors.
 - 4. Connections to Structural Steel: Welded connectors.

3.2 EQUIPMENT GROUNDING

- A. Install insulated equipment grounding conductors with all feeders and branch circuits.
- B. Isolated Grounding Receptacle Circuits: Install an insulated equipment grounding conductor connected to the receptacle grounding terminal. Isolate conductor from raceway and from panelboard grounding terminals. Terminate at equipment grounding conductor terminal of the applicable derived system or service unless otherwise indicated.
- C. Isolated Equipment Enclosure Circuits: For designated equipment supplied by a branch circuit or feeder, isolate equipment enclosure from supply circuit raceway with a nonmetallic raceway fitting listed for the purpose. Install fitting where raceway enters enclosure, and install a separate insulated equipment grounding conductor. Isolate conductor from raceway and from panelboard grounding terminals. Terminate at equipment grounding conductor terminal of the applicable derived system or service unless otherwise indicated.
- D. Signal and Communication Equipment: In addition to grounding and bonding required by NFPA 70, provide a separate grounding system complying with requirements in TIA/ATIS J-STD-607-A.
 - 1. For telephone, alarm, voice and data, and other communication equipment, provide No. 4 AWG minimum insulated grounding conductor in raceway from grounding electrode system to each service location, terminal cabinet, wiring closet, and central equipment location.

3.3 INSTALLATION

- A. Grounding Conductors: Route along shortest and straightest paths possible unless otherwise indicated or required by Code. Avoid obstructing access or placing conductors where they may be subjected to strain, impact, or damage.
- B. Ground Bonding Common with Lightning Protection System: Comply with NFPA 780 and UL 96 when interconnecting with lightning protection system. Bond electrical power system ground directly to lightning protection system grounding conductor at closest point to electrical service grounding electrode. Use bonding conductor sized same as system grounding electrode conductor, and install in conduit.
- C. Ground Rods: Drive rods until tops are 2 inches (50 mm) below finished floor or final grade unless otherwise indicated.
 - 1. Interconnect ground rods with grounding electrode conductor below grade and as otherwise indicated. Make connections without exposing steel or damaging coating if any.
 - 2. For grounding electrode system, install at least three rods spaced at least one-rod length from each other and located at least the same distance from other grounding electrodes, and connect to the service grounding electrode conductor.

- D. Test Wells: Ground rod driven through drilled hole in bottom of handhole. Handholes are specified in Section 260543 "Underground Ducts and Raceways for Electrical Systems," and shall be at least 12 inches (300 mm) deep, with cover.
 - 1. Test Wells: Install at least one test well for each service unless otherwise indicated. Install at the ground rod electrically closest to service entrance. Set top of test well flush with finished grade or floor.
- E. Bonding Straps and Jumpers: Install in locations accessible for inspection and maintenance except where routed through short lengths of conduit.
 - 1. Bonding to Structure: Bond straps directly to basic structure, taking care not to penetrate any adjacent parts.
 - 2. Bonding to Equipment Mounted on Vibration Isolation Hangers and Supports: Install bonding so vibration is not transmitted to rigidly mounted equipment.
 - 3. Use exothermic-welded connectors for outdoor locations; if a disconnect-type connection is required, use a bolted clamp.
- F. Grounding and Bonding for Piping:
 - 1. Metal Water Service Pipe: Install insulated copper grounding conductors, in conduit, from building's main service equipment, or grounding bus, to main metal water service entrances to building. Connect grounding conductors to main metal water service pipes; use a bolted clamp connector or bolt a lug-type connector to a pipe flange by using one of the lug bolts of the flange. Where a dielectric main water fitting is installed, connect grounding conductor on street side of fitting. Bond metal grounding conductor conduit or sleeve to conductor at each end.
 - 2. Water Meter Piping: Use braided-type bonding jumpers to electrically bypass water meters. Connect to pipe with a bolted connector.
 - 3. Bond each aboveground portion of gas piping system downstream from equipment shutoff valve.
- G. Bonding Interior Metal Ducts: Bond metal air ducts to equipment grounding conductors of associated fans, blowers, electric heaters, and air cleaners. Install [tinned] bonding jumper to bond across flexible duct connections to achieve continuity.
- H. Grounding for Steel Building Structure: Install a driven ground rod at base of each corner column and at intermediate exterior columns at distances not more than 60 feet (18 m) apart.
- I. Ufer Ground (Concrete-Encased Grounding Electrode): Fabricate according to NFPA 70; use a minimum of 20 feet (6 m) of bare copper conductor not smaller than No. 4/0 AWG.
 - 1. If concrete foundation is less than 20 feet (6 m) long, coil excess conductor within base of foundation.
 - 2. Bond grounding conductor to reinforcing steel in at least four locations and to anchor bolts. Extend grounding conductor below grade and connect to building's grounding grid or to grounding electrode external to concrete.

3.4 LABELING

- A. Comply with requirements in Section 260553 "Identification for Electrical Systems" for instruction signs. The label or its text shall be green.
- B. Install labels at the telecommunications bonding conductor and grounding equalizer and at the grounding electrode conductor where exposed.
 - 1. Label Text: "If this connector or cable is loose or if it must be removed for any reason, notify the facility manager."

3.5 FIELD QUALITY CONTROL

- A. Perform tests and inspections.
 - 1. Manufacturer's Field Service: Engage a factory-authorized service representative to inspect components, assemblies, and equipment installations, including connections, and to assist in testing.
- B. Tests and Inspections:

1. After installing grounding system but before permanent electrical circuits have been energized, test for compliance with requirements.
 2. Inspect physical and mechanical condition. Verify tightness of accessible, bolted, electrical connections with a calibrated torque wrench according to manufacturer's written instructions.
 3. Test completed grounding system at each location where a maximum ground-resistance level is specified, at service disconnect enclosure grounding terminal, at ground test wells. Make tests at ground rods before any conductors are connected.
 - a. Measure ground resistance no fewer than two full days after last trace of precipitation and without soil being moistened by any means other than natural drainage or seepage and without chemical treatment or other artificial means of reducing natural ground resistance.
 - b. Perform tests by fall-of-potential method according to IEEE 81.
 4. Prepare dimensioned Drawings locating each test well, ground rod and ground-rod assembly, and other grounding electrodes. Identify each by letter in alphabetical order, and key to the record of tests and observations. Include the number of rods driven and their depth at each location, and include observations of weather and other phenomena that may affect test results. Describe measures taken to improve test results.
- C. Grounding system will be considered defective if it does not pass tests and inspections.
- D. Prepare test and inspection reports.
- E. Report measured ground resistances that exceed the following values:
1. Power and Lighting Equipment or System with Capacity of 500 kVA and Less: 10 ohms.
 2. Power and Lighting Equipment or System with Capacity of 500 to 1000 kVA: 5 ohms.
 3. Power and Lighting Equipment or System with Capacity More Than 1000 kVA: 3 ohms.
- F. Excessive Ground Resistance: If resistance to ground exceeds specified values, notify Architect promptly and include recommendations to reduce ground resistance.

END OF SECTION

THIS PAGE LEFT BLANK INTENTIONALLY

SECTION 26 0529

HANGERS AND SUPPORTS FOR ELECTRICAL SYSTEMS

PART 1 - GENERAL

1.1 RELATED DOCUMENTS

- A. Drawings and general provisions of the Contract, including General and Supplementary Conditions and Division 01 Specification Sections, apply to this Section.

1.2 SUMMARY

- A. This Section includes the following:
 - 1. Hangers and supports for electrical equipment and systems.
 - 2. Construction requirements for concrete bases.
- B. Related Sections include the following:
 - 1. Section 260548 "Vibration and Seismic Controls for Electrical Systems" for products and installation requirements necessary for compliance with seismic criteria.

1.3 DEFINITIONS

- A. EMT: Electrical metallic tubing.
- B. IMC: Intermediate metal conduit.
- C. RMC: Rigid metal conduit.

1.4 PERFORMANCE REQUIREMENTS

- A. Delegated Design: Design supports for multiple raceways, including comprehensive engineering analysis by a qualified professional engineer, using performance requirements and design criteria indicated.
- B. Design supports for multiple raceways capable of supporting combined weight of supported systems and its contents.
- C. Design equipment supports capable of supporting combined operating weight of supported equipment and connected systems and components.
- D. Rated Strength: Adequate in tension, shear, and pullout force to resist maximum loads calculated or imposed for this Project, with a minimum structural safety factor of five times the applied force.

1.5 ACTION SUBMITTALS

- A. Product Data: For the following:
 - 1. Steel slotted support systems.
 - 2. Nonmetallic slotted support systems.
- B. Shop Drawings: Signed and sealed by a qualified professional engineer. Show fabrication and installation details and include calculations for the following:
 - 1. Trapeze hangers. Include Product Data for components.
 - 2. Steel slotted channel systems. Include Product Data for components.
 - 3. Nonmetallic slotted channel systems. Include Product Data for components.
 - 4. Equipment supports.

1.6 INFORMATIONAL SUBMITTALS

- A. Welding certificates.

1.7 QUALITY ASSURANCE

- A. Welding: Qualify procedures and personnel according to AWS D1.1/D1.1M, "Structural Welding Code - Steel."
- B. Comply with NFPA 70.

1.8 COORDINATION

- A. Coordinate size and location of concrete bases. Cast anchor-bolt inserts into bases. Concrete, reinforcement, and formwork requirements are specified together with concrete Specifications.
- B. Coordinate installation of roof curbs, equipment supports, and roof penetrations. These items are specified in Section 077200 "Roof Accessories."

PART 2 - PRODUCTS

2.1 SUPPORT, ANCHORAGE, AND ATTACHMENT COMPONENTS

- A. Steel Slotted Support Systems: Comply with MFMA-4, factory-fabricated components for field assembly.
 - 1. Available Manufacturers: Subject to compliance with requirements, manufacturers offering products that may be incorporated into the Work include, but are not limited to, the following:
 - a. Allied Tube & Conduit.
 - b. Cooper B-Line, Inc.; a division of Cooper Industries.
 - c. ERICO International Corporation.
 - d. GS Metals Corp.
 - e. Thomas & Betts Corporation.
 - f. Unistrut; Tyco International, Ltd.
 - g. Wesanco, Inc.
 - 2. Metallic Coatings: Hot-dip galvanized after fabrication and applied according to MFMA-4.
 - 3. Nonmetallic Coatings: Manufacturer's standard PVC, polyurethane, or polyester coating applied according to MFMA-4.
 - 4. Painted Coatings: Manufacturer's standard painted coating applied according to MFMA-4.
 - 5. Channel Dimensions: Selected for applicable load criteria.
- B. Raceway and Cable Supports: As described in NECA 1 and NECA 101.
- C. Conduit and Cable Support Devices: Steel hangers, clamps, and associated fittings, designed for types and sizes of raceway or cable to be supported.
- D. Support for Conductors in Vertical Conduit: Factory-fabricated assembly consisting of threaded body and insulating wedging plug or plugs for non-armored electrical conductors or cables in riser conduits. Plugs shall have number, size, and shape of conductor gripping pieces as required to suit individual conductors or cables supported. Body shall be malleable iron.
- E. Structural Steel for Fabricated Supports and Restraints: ASTM A 36/A 36M, steel plates, shapes, and bars; black and galvanized.
- F. Mounting, Anchoring, and Attachment Components: Items for fastening electrical items or their supports to building surfaces include the following:
 - 1. Powder-Actuated Fasteners: Threaded-steel stud, for use in hardened portland cement concrete, steel, or wood, with tension, shear, and pullout capacities appropriate for supported loads and building materials where used.
 - a. Manufacturers: Subject to compliance with requirements, provide products by one of the following:
 - 1) Hilti Inc.
 - 2) ITW Ramset/Red Head; a division of Illinois Tool Works, Inc.
 - 3) MKT Fastening, LLC.
 - 4) Simpson Strong-Tie Co., Inc.; Masterset Fastening Systems Unit.

2. Mechanical-Expansion Anchors: Insert-wedge-type, zinc-coated steel, for use in hardened portland cement concrete with tension, shear, and pullout capacities appropriate for supported loads and building materials in which used.
 - a. Manufacturers: Subject to compliance with requirements, provide products by one of the following:
 - 1) Cooper B-Line, Inc.; a division of Cooper Industries.
 - 2) Empire Tool and Manufacturing Co., Inc.
 - 3) Hilti Inc.
 - 4) ITW Ramset/Red Head; a division of Illinois Tool Works, Inc.
 - 5) MKT Fastening, LLC.
3. Concrete Inserts: Steel or malleable-iron, slotted support system units similar to MSS Type 18; complying with MFMA-4 or MSS SP-58.
4. Clamps for Attachment to Steel Structural Elements: MSS SP-58, type suitable for attached structural element.
5. Through Bolts: Structural type, hex head, and high strength. Comply with ASTM A 325.
6. Toggle Bolts: All-steel springhead type.
7. Hanger Rods: Threaded steel.

2.2 FABRICATED METAL EQUIPMENT SUPPORT ASSEMBLIES

- A. Description: Welded or bolted, structural-steel shapes, shop or field fabricated to fit dimensions of supported equipment.
- B. Materials: Comply with requirements in Section 055000 "Metal Fabrications" for steel shapes and plates.

PART 3 - EXECUTION

3.1 APPLICATION

- A. Comply with NECA 1 and NECA 101 for application of hangers and supports for electrical equipment and systems except if requirements in this Section are stricter.
- B. Maximum Support Spacing and Minimum Hanger Rod Size for Raceway: Space supports for EMT, IMC, and RMC as required by NFPA 70. Minimum rod size shall be 1/4 inch (6 mm) in diameter.
- C. Multiple Raceways or Cables: Install trapeze-type supports fabricated with steel slotted or other support system, sized so capacity can be increased by at least 25 percent in future without exceeding specified design load limits.
 1. Secure raceways and cables to these supports with single-bolt conduit clamps using spring friction action for retention in support channel.
- D. Spring-steel clamps designed for supporting single conduits without bolts may be used for 1-1/2-inch (38-mm) and smaller raceways serving branch circuits and communication systems above suspended ceilings and for fastening raceways to trapeze supports.

3.2 SUPPORT INSTALLATION

- A. Comply with NECA 1 and NECA 101 for installation requirements except as specified in this Article.
- B. Strength of Support Assemblies: Where not indicated, select sizes of components so strength will be adequate to carry present and future static loads within specified loading limits. Minimum static design load used for strength determination shall be weight of supported components plus 200 lb (90 kg).
- C. Mounting and Anchorage of Surface-Mounted Equipment and Components: Anchor and fasten electrical items and their supports to building structural elements by the following methods unless otherwise indicated by code:
 1. To New Concrete: Bolt to concrete inserts.
 2. To Masonry: Approved toggle-type bolts on hollow masonry units and expansion anchor fasteners on solid masonry units.

3. To Steel: Beam clamps (MSS Type 19, 21, 23, 25, or 27) complying with MSS SP-69.
 4. To Light Steel: Sheet metal screws.
 5. Items Mounted on Hollow Walls and Nonstructural Building Surfaces: Mount cabinets, panelboards, disconnect switches, control enclosures, pull and junction boxes, transformers, and other devices on slotted-channel racks attached to substrate by means that meet seismic-restraint strength and anchorage requirements.
- D. Drill holes for expansion anchors in concrete at locations and to depths that avoid reinforcing bars.

3.3 INSTALLATION OF FABRICATED METAL SUPPORTS

- A. Comply with installation requirements in Section 055000 "Metal Fabrications" for site-fabricated metal supports.
- B. Cut, fit, and place miscellaneous metal supports accurately in location, alignment, and elevation to support and anchor electrical materials and equipment.
- C. Field Welding: Comply with AWS D1.1/D1.1M.

3.4 CONCRETE BASES

- A. Construct concrete bases of dimensions indicated but not less than 4 inches (100 mm) larger in both directions than supported unit, and so anchors will be a minimum of 10 bolt diameters from edge of the base.
- B. Use 3000-psi (20.7-MPa), 28-day compressive-strength concrete. Concrete materials, reinforcement, and placement requirements are specified in Section 033000 "Cast-in-Place Concrete" or Section 033053 "Miscellaneous Cast-in-Place Concrete."
- C. Anchor equipment to concrete base.
 1. Place and secure anchorage devices. Use supported equipment manufacturer's setting drawings, templates, diagrams, instructions, and directions furnished with items to be embedded.
 2. Install anchor bolts to elevations required for proper attachment to supported equipment.
 3. Install anchor bolts according to anchor-bolt manufacturer's written instructions.

3.5 PAINTING

- A. Touchup: Clean field welds and abraded areas of shop paint. Paint exposed areas immediately after erecting hangers and supports. Use same materials as used for shop painting. Comply with SSPC-PA 1 requirements for touching up field-painted surfaces.
 1. Apply paint by brush or spray to provide minimum dry film thickness of 2.0 mils (0.05 mm).
- B. Galvanized Surfaces: Clean welds, bolted connections, and abraded areas and apply galvanizing-repair paint to comply with ASTM A 780.

END OF SECTION

SECTION 26 0533

RACEWAYS AND BOXES FOR ELECTRICAL SYSTEMS

PART 1 - GENERAL

1.1 RELATED DOCUMENTS

- A. Drawings and general provisions of the Contract, including General and Supplementary Conditions and Division 01 Specification Sections, apply to this Section.

1.2 SUMMARY

- A. Section Includes:
 - 1. Metal conduits, tubing, and fittings.
 - 2. Nonmetal conduits, tubing, and fittings.
 - 3. Metal wireways and auxiliary gutters.
 - 4. Surface raceways.
 - 5. Boxes, enclosures, and cabinets.
 - 6. Handholes and boxes for exterior underground cabling.
- B. Related Requirements:
 - 1. Section 26 05 43 "Underground Ducts and Raceways for Electrical Systems" for exterior ductbanks, manholes, and underground utility construction.

1.3 DEFINITIONS

- A. ARC: Aluminum Rigid Conduit.
- B. EMT: Electrical Metallic Tubing.
- C. GRC: Galvanized rigid steel conduit.
- D. IMC: Intermediate metal conduit.
- E. RTRC: Reinforced Thermosetting Resin Conduit.

1.4 ACTION SUBMITTALS

- A. Product Data: For color coded EMT conduit, surface raceways, wireways and fittings, floor boxes, hinged-cover enclosures, and cabinets.
- B. LEED Submittals:
 - 1. Product Data for Credit IEQ 4.1: For solvent cements and adhesive primers, documentation including printed statement of VOC content.
 - 2. Laboratory Test Reports for Credit IEQ 4: For solvent cements and adhesive primers, documentation indicating that products comply with the testing and product requirements of the California Department of Health Services' "Standard Practice for the Testing of

Volatile Organic Emissions from Various Sources Using Small-Scale Environmental Chambers."

- C. Shop Drawings: For custom enclosures and cabinets. Include plans, elevations, sections, and attachment details.
- D. Samples: For receptacle raceways and for each color and texture specified, 12 inches (300 mm) long.

1.5 INFORMATIONAL SUBMITTALS

- A. Coordination Drawings: Conduit routing plans, drawn to scale, on which the following items are shown and coordinated with each other, using input from installers of items involved:
 - 1. Structural members in paths of conduit groups with common supports.
 - 2. HVAC and plumbing items and architectural features in paths of conduit groups with common supports.
- B. Qualification Data: For professional engineer.
- C. Seismic Qualification Certificates: For enclosures, cabinets, and conduit racks and their mounting provisions, including those for internal components, from manufacturer.
 - 1. Basis for Certification: Indicate whether withstand certification is based on actual test of assembled components or on calculation.
 - 2. Dimensioned Outline Drawings of Equipment Unit: Identify center of gravity and locate and describe mounting and anchorage provisions.
 - 3. Detailed description of equipment anchorage devices on which the certification is based and their installation requirements.
 - 4. Detailed description of conduit support devices and interconnections on which the certification is based and their installation requirements.
- D. Source quality-control reports.

PART 2 - PRODUCTS

2.1 METAL CONDUITS, TUBING, AND FITTINGS

- A. Listing and Labeling: Metal conduits, tubing, and fittings shall be listed and labeled as defined in NFPA 70, by a qualified testing agency, and marked for intended location and application.
- B. GRC: Comply with ANSI C80.1 and UL 6.
- C. ARC: Comply with ANSI C80.5 and UL 6A.
- D. IMC: Comply with ANSI C80.6 and UL 1242.
- E. EMT: Comply with ANSI C80.3 and UL 797. Factory applied color finish available in black, orange, green, purple, red, yellow, blue, and white. Refer to Specification Section 26 05 53 "Identification for Electrical Systems" for color coding of raceways.
- F. FMC: Comply with UL 1; zinc-coated steel.
- G. LFMC: Flexible steel conduit with PVC jacket and complying with UL 360.

- H. Fittings for Metal Conduit: Comply with NEMA FB 1 and UL 514B.
 - 1. Conduit Fittings for Hazardous (Classified) Locations: Comply with UL 886 and NFPA 70.
 - 2. Fittings for EMT:
 - a. Material: Steel.
 - b. Type: compression.
 - 3. Expansion Fittings: PVC or steel to match conduit type, complying with UL 651, rated for environmental conditions where installed, and including flexible external bonding jumper.
- I. Joint Compound for IMC, GRC, or ARC: Approved, as defined in NFPA 70, by authorities having jurisdiction for use in conduit assemblies, and compounded for use to lubricate and protect threaded conduit joints from corrosion and to enhance their conductivity.

2.2 NONMETALLIC CONDUITS, TUBING, AND FITTINGS

- A. Listing and Labeling: Nonmetallic conduits, tubing, and fittings shall be listed and labeled as defined in NFPA 70, by a qualified testing agency, and marked for intended location and application.
- B. RNC: Type EPC-40-PVC, complying with NEMA TC 2 and UL 651 unless otherwise indicated.
- C. Continuous HDPE: Comply with UL 651B.
- D. RTRC: Comply with UL 1684A and NEMA TC 14.
- E. Fittings for RNC: Comply with NEMA TC 3; match to conduit or tubing type and material.
- F. Solvent cements and adhesive primers shall have a VOC content of 510 and 550 g/L or less, respectively, when calculated according to 40 CFR 59, Subpart D (EPA Method 24).
- G. Solvent cements and adhesive primers shall comply with the testing and product requirements of the California Department of Health Services' "Standard Practice for the Testing of Volatile Organic Emissions from Various Sources Using Small-Scale Environmental Chambers."

2.3 METAL WIREWAYS AND AUXILIARY GUTTERS

- A. Description: Sheet metal, complying with UL 870 and NEMA 250, Type 1 unless otherwise indicated, and sized according to NFPA 70.
 - 1. Metal wireways installed outdoors shall be listed and labeled as defined in NFPA 70, by a qualified testing agency, and marked for intended location and application.
- B. Fittings and Accessories: Include covers, couplings, offsets, elbows, expansion joints, adapters, hold-down straps, end caps, and other fittings to match and mate with wireways as required for complete system.
- C. Wireway Covers: Hinged type unless otherwise indicated.
- D. Finish: Manufacturer's standard enamel finish.

2.4 RECEPTACLE RACEWAYS

- A. Listing and Labeling: Receptacle raceways shall be listed and labeled as defined in NFPA 70, by a qualified testing agency, and marked for intended location and application.

- B. Surface Metal Raceways: Aluminum with snap-on covers complying with UL. Clear anodized finish.
 - 1. Raceways for receptacles only: Wiremold AL3300 series.
 - 2. Raceways for applications where both receptacles and data devices are installed in the raceway and at all laboratory locations: Wiremold ALA4800 series two-channel and dual-cover. Satin anodized finish.
 - 3. Provide duplex receptacles at 12 inches on center in all receptacle raceways. Provide GFCI receptacles as noted on drawings.

2.5 BOXES, ENCLOSURES, AND CABINETS

- A. General Requirements for Boxes, Enclosures, and Cabinets: Boxes, enclosures, and cabinets installed in wet locations shall be listed for use in wet locations.
- B. Sheet Metal Outlet and Device Boxes: Comply with NEMA OS 1 and UL 514A.
- C. Cast-Metal Outlet and Device Boxes: Comply with NEMA FB 1, aluminum, Type FD, with gasketed cover.
- D. Nonmetallic Outlet and Device Boxes: Comply with NEMA OS 2 and UL 514C.
- E. Floor Boxes and Poke-Through Devices: Refer to Specification Section 26 27 26 "Wiring Devices" for floor boxes and poke-through devices
- F. Luminaire Outlet Boxes: Nonadjustable, designed for attachment of luminaire weighing 50 lb (23 kg). Outlet boxes designed for attachment of luminaires weighing more than 50 lb (23 kg) shall be listed and marked for the maximum allowable weight.
- G. Small Sheet Metal Pull and Junction Boxes: NEMA OS 1.
- H. Cast-Metal Access, Pull, and Junction Boxes: Comply with NEMA FB 1 and UL 1773, cast aluminum with gasketed cover.
- I. Box extensions used to accommodate new building finishes shall be of same material as recessed box.
- J. Device Box Dimensions:
 - 1. Wiring Devices other than data or communications devices: Minimum 4 inches square by 2-1/8 inches deep with switch ring as required for the device configuration and wall or ceiling surface. Where light switches are indicated at a common location provide multi-gang boxes to accommodate the quantity and type of switches indicated. Where deeper boxes are required provide masonry type boxes which do not require a separate switch ring.
 - 2. Data and communications devices: Minimum 4-11/16 inches square by 3 inches deep with single-gang 5/8 inch deep (or deeper if wall or ceiling finish is deeper) ring.
- K. Pull boxes behind monitors: Minimum 6 inches square by 3-1/2 inches deep with two-gang ring.
- L. Gangable boxes are prohibited.
- M. Partitions: Provide partitions to separate emergency system conductors from conductors or other systems, where voltage between adjacent switches exceeds 300 volts and where switches controlling Low Voltage Controllers for interface to Nurse Call systems are installed in common boxes with line voltage switches.

- N. Hinged-Cover Enclosures: Comply with UL 50 and NEMA 250.
1. Indoor: Type 1 with continuous-hinge cover with flush latch unless otherwise indicated. Steel, finished inside and out with manufacturer's standard enamel.
 2. Outdoor: Type 4X with continuous-hinge cover with flush latch unless otherwise indicated. 304 stainless steel with smooth brushed finish.
 3. Interior Panels: Steel; all sides finished with manufacturer's standard enamel. Provide interior panels when there are control devices or power blocks located inside the enclosure.
- O. Handholes and Boxes for Exterior Underground Wiring: Refer to Specification Section 26 05 43 "Underground Ducts and Raceways for Electrical Systems".

2.6 PUTTY PADS

- A. Moldable intumescent wall opening-protective pads designed for application to the back of electrical outlet boxes prior to installation of the wall finish to provide up to 2-hour fire barrier ratings and minimum Sound Transmission Class (STC) of 52 when tested in an STC-53 rated wall assembly or 59 according to ASTM E90-97.
- B. **Manufacturers:** Subject to compliance with requirements, provide products by one of the following:
1. [3M Company](#).
 2. [Hilti](#)

PART 3 - EXECUTION

3.1 RACEWAY APPLICATION

- A. Outdoors: Apply raceway products as specified below unless otherwise indicated:
1. Exposed Conduit: GRC or IMC.
 2. Concealed Conduit, Aboveground: EMT.
 3. Underground Conduit for branch circuits: RNC, Type EPC-40-PVC, direct buried.
 4. Underground Conduit for feeders: Refer to Specification Section 26 05 43 "Underground Ducts and Raceways for Electrical Systems".
 5. Raceways Embedded in slabs or composite steel and concrete decks are prohibited.
 6. Connection to Vibrating Equipment (Including Transformers and Hydraulic, Pneumatic, Electric Solenoid, or Motor-Driven Equipment): LFMC.
 7. Boxes and Enclosures, Aboveground: NEMA 250, Type 4X, 304 stainless steel.
- B. Indoors: Apply raceway products as specified below unless otherwise indicated:
1. Exposed, Not Subject to Physical Damage: EMT.
 2. Exposed, Not Subject to Severe Physical Damage: EMT.
 3. Exposed and Subject to Severe Physical Damage: GRC or IMC. Raceway locations include the following:
 - a. Loading dock.
 - b. Corridors used for traffic of mechanized carts, forklifts, and pallet-handling units.
 - c. Mechanical rooms below 8 feet.
 - d. Gymnasiums.
 4. Concealed in Ceilings and Interior Walls and Partitions: EMT.
 5. Feeder Raceways under Slabs: RNC, Type EPC-40-PVC encased in not less than 2 inches of 3000 psi concrete. Change from RNC, Type EPC-40-PVC to GRC or IMC before rising above floor.

6. Branch Circuit Raceways under Slabs: Refer to Specifications Section 26 05 19 "Low-Voltage Electrical Power Conductors and Cables" for allowable application of under slab raceways. RNC, Type EPC-40-PVC direct buried. Change from RNC, Type EPC-40-PVC to GRC or IMC before rising above floor.
 7. Raceways Embedded in slabs or composite steel and concrete decks are prohibited.
 8. Connection to Vibrating Equipment (Including Transformers and Hydraulic, Pneumatic, Electric Solenoid, or Motor-Driven Equipment): FMC, except use LFMC in damp or wet locations.
 9. Damp or Wet Locations: GRC or IMC.
 10. Boxes and Enclosures: NEMA 250, Type 1, except use NEMA 250, Type 4X, 304 stainless steel in kitchens and damp or wet locations.
 - 11.
- C. Minimum Raceway Size: **3/4-inch (21-mm)** trade size.
- D. Raceway Fittings: Compatible with raceways and suitable for use and location.
1. Rigid and Intermediate Steel Conduit: Use threaded rigid steel conduit fittings unless otherwise indicated. Comply with NEMA FB 2.10.
 2. EMT: Use setscrew or compression, steel fittings. Comply with NEMA FB 2.10.
 3. Flexible Conduit: Use only fittings listed for use with flexible conduit. Comply with NEMA FB 2.20.
- E. Install nonferrous conduit or tubing for circuits operating above 60 Hz. Where aluminum raceways are installed for such circuits and pass through concrete, install in nonmetallic sleeve.
- F. Do not install aluminum conduits, boxes, or fittings in contact with concrete or earth.
- G. Install surface raceways only where indicated on Drawings.

3.2 INSTALLATION

- A. Comply with NECA 1 and NECA 101 for installation requirements except where requirements on Drawings or in this article are stricter. Comply with NECA 102 for aluminum conduits. Comply with NFPA 70 limitations for types of raceways allowed in specific occupancies and number of floors.
- B. Separation of Life Safety and Critical Branch Wiring: Comply with NFPA 70 Article 517.
- C. Keep raceways at least **6 inches (150 mm)** away from parallel runs of flues and steam or hot-water pipes. Install horizontal raceway runs above water and steam piping.
- D. Complete raceway installation before starting conductor installation.
- E. Comply with requirements in Section 26 05 29 "Hangers and Supports for Electrical Systems" for hangers and supports.
- F. Arrange stub-ups so curved portions of bends are not visible above finished slab except where concealed in chases.
- G. Install no more than the equivalent of three 90-degree bends in any conduit run except for control wiring conduits, for which fewer bends are allowed. Support within **12 inches (300 mm)** of changes in direction.

- H. Conceal conduit and EMT within finished walls, ceilings, and floors unless otherwise indicated. Install conduits parallel or perpendicular to building lines.
- I. Support conduit within **12 inches (300 mm)** of enclosures to which attached.
- J. Raceways Embedded in Slabs are prohibited.
- K. Stub-ups to Above Recessed Ceilings:
 - 1. Use EMT, IMC, or RMC for raceways.
 - 2. Use a conduit bushing or insulated fitting to terminate stub-ups not terminated in hubs or in an enclosure.
- L. Threaded Conduit Joints, Exposed to Wet, Damp, Corrosive, or Outdoor Conditions: Apply listed compound to threads of raceway and fittings before making up joints. Follow compound manufacturer's written instructions.
- M. Coat field-cut threads on PVC-coated raceway with a corrosion-preventing conductive compound prior to assembly.
- N. Raceway Terminations at Locations Subject to Moisture or Vibration: Use insulating bushings to protect conductors including conductors smaller than No. 4 AWG.
- O. Terminate threaded conduits into threaded hubs or with locknuts on inside and outside of boxes or cabinets. Install bushings on conduits up to **1-1/4-inch (35mm)** trade size and insulated throat metal bushings on **1-1/2-inch (41-mm)** trade size and larger conduits terminated with locknuts. Install insulated throat metal grounding bushings on service conduits.
- P. Install raceways square to the enclosure and terminate at enclosures with locknuts. Install locknuts hand tight plus 1/4 turn more.
- Q. Do not rely on locknuts to penetrate nonconductive coatings on enclosures. Remove coatings in the locknut area prior to assembling conduit to enclosure to assure a continuous ground path.
- R. Cut conduit perpendicular to the length. For conduits **2-inch (53-mm)** trade size and larger, use roll cutter or a guide to make cut straight and perpendicular to the length.
- S. Install pull wires in empty raceways. Use polypropylene or monofilament plastic line with not less than **200-lb (90-kg)** tensile strength. Leave at least **12 inches (300 mm)** of slack at each end of pull wire. Cap underground raceways designated as spare above grade alongside raceways in use.
- T. Surface Raceways:
 - 1. Install surface raceway with a minimum **2-inch (50-mm)** radius control at bend points.
 - 2. Secure surface raceway with screws or other anchor-type devices at intervals not exceeding **48 inches (1200 mm)** and with no less than two supports per straight raceway section. Support surface raceway according to manufacturer's written instructions. Tape and glue are not acceptable support methods.
- U. Install raceway sealing fittings at accessible locations according to NFPA 70 and fill them with listed sealing compound. For concealed raceways, install each fitting in a flush steel box with a blank cover plate having a finish similar to that of adjacent plates or surfaces. Install raceway sealing fittings according to NFPA 70.

- V. Install devices to seal raceway interiors at accessible locations. Locate seals so no fittings or boxes are between the seal and the following changes of environments. Seal the interior of all raceways at the following points:
 - 1. Where conduits pass from warm to cold locations, such as boundaries of refrigerated spaces.
 - 2. Where an underground service raceway enters a building or structure.
 - 3. Where otherwise required by NFPA 70.
- W. Comply with manufacturer's written instructions for solvent welding RNC and fittings.
- X. Expansion(Seismic)-Joint Fittings:
 - 1. Install flexible metal conduit at all locations where conduits cross building or structure expansion joints. Allow for minimum 4 inches deflection in all directions or greater if expansion joint exceeds 4 inches. Provide droop in flexible conduit to accommodate movement. Do not loop the flexible conduit. When calculating total bend degrees in conduit runs with expansion fittings use minimum 60 degrees for each expansion-joint fitting
 - 2. Install each expansion-joint fitting with position, mounting, and piston setting selected according to manufacturer's written instructions for conditions at specific location at time of installation. Install conduit supports to allow for expansion movement.
- Y. Flexible Conduit Connections: Comply with NEMA RV 3. Use a maximum of **72 inches (1830 mm)** of flexible conduit for recessed and semi-recessed luminaires, equipment subject to vibration, noise transmission, or movement; and for transformers and motors.
 - 1. Use LFMC in damp or wet locations.
- Z. Mount boxes at heights indicated on Drawings. If mounting heights of boxes are not individually indicated, give priority to ADA requirements. Install boxes with height measured to center of box unless otherwise indicated.
- AA. Recessed Boxes in Masonry Walls: Saw-cut opening for box in center of cell of masonry block, and install box flush with surface of wall. Prepare block surfaces to provide a flat surface for a raintight connection between box and cover plate or supported equipment and box.
- BB. Horizontally separate boxes mounted on opposite sides of walls so they are not in the same vertical channel.
- CC. Locate boxes so that cover or plate will not span different building finishes.
- DD. Support boxes of three gangs or more from more than one side by spanning two framing members or mounting on brackets specifically designed for the purpose.
- EE. Fasten junction and pull boxes to or support from building structure. Do not support boxes by conduits.
- FF. Set metal floor boxes level and flush with finished floor surface.
- GG. Set nonmetallic floor boxes level. Trim after installation to fit flush with finished floor surface.

3.3 SLEEVE AND SLEEVE-SEAL INSTALLATION FOR ELECTRICAL PENETRATIONS

- A. Install sleeves and sleeve seals at penetrations of exterior floor and wall assemblies. Comply with requirements in Section 26 05 44 "Sleeves and Sleeve Seals for Electrical Raceways and Cabling."

3.4 FIRESTOPPING AND SOUND TRANSMISSION MITIGATION

- A. Install firestopping at penetrations of fire-rated floor and wall assemblies. Comply with requirements in Section 07 84 13 "Penetration Firestopping."
- B. Install putty pads with acoustical and firestopping capabilities on all boxes that are installed in wall or partition cavities and in gypsum board ceilings.

3.5 PROTECTION

- A. Protect coatings, finishes, and cabinets from damage and deterioration.
 - 1. Repair damage to galvanized finishes with zinc-rich paint recommended by manufacturer.
 - 2. Repair damage to PVC coatings or paint finishes with matching touchup coating recommended by manufacturer.

END OF SECTION

THIS PAGE LEFT BLANK INTENTIONALLY

SECTION 26 0548

VIBRATION AND SEISMIC CONTROLS FOR ELECTRICAL SYSTEMS

PART 1 - GENERAL

1.1 RELATED DOCUMENTS

- A. Drawings and general provisions of the Contract, including General and Supplementary Conditions and Division 01 Specification Sections, apply to this Section.

1.2 SUMMARY

- A. This Section includes the following:
 - 1. Isolation pads.
 - 2. Spring isolators.
 - 3. Restrained spring isolators.
 - 4. Channel support systems.
 - 5. Restraint cables.
 - 6. Hanger rod stiffeners.
 - 7. Anchorage bushings and washers.
- B. Related Sections include the following:
 - 1. Section 260529 "Hangers and Supports for Electrical Systems" for commonly used electrical supports and installation requirements.

1.3 DEFINITIONS

- A. The IBC: International Building Code.
- B. ICC-ES: ICC-Evaluation Service.
- C. OSHPD: Office of Statewide Health Planning and Development for the State of California.

1.4 PERFORMANCE REQUIREMENTS

- A. Seismic-Restraint Loading: Refer to structural specifications.

1.5 ACTION SUBMITTALS

- A. Product Data: For the following:
 - 1. Include rated load, rated deflection, and overload capacity for each vibration isolation device.
 - 2. Illustrate and indicate style, material, strength, fastening provision, and finish for each type and size of seismic-restraint component used.
 - a. Tabulate types and sizes of seismic restraints, complete with report numbers and rated strength in tension and shear as evaluated by an evaluation service member of ICC-ES.
 - b. Annotate to indicate application of each product submitted and compliance with requirements.
 - 3. Restrained-Isolation Devices: Include ratings for horizontal, vertical, and combined loads.
- B. Delegated-Design Submittal: For seismic-restraint details indicated to comply with performance requirements and design criteria, including analysis data signed and sealed by the qualified professional engineer responsible for their preparation.
 - 1. Design Calculations: Calculate static and dynamic loading due to equipment weight and operation, seismic forces required to select vibration isolators and seismic restraints.

- a. Coordinate design calculations with wind-load calculations required for equipment mounted outdoors. Comply with requirements in other electrical Sections for equipment mounted outdoors.
2. Indicate materials and dimensions and identify hardware, including attachment and anchorage devices.
3. Field-fabricated supports.
4. Seismic-Restraint Details:
 - a. Design Analysis: To support selection and arrangement of seismic restraints. Include calculations of combined tensile and shear loads.
 - b. Details: Indicate fabrication and arrangement. Detail attachments of restraints to the restrained items and to the structure. Show attachment locations, methods, and spacings. Identify components, list their strengths, and indicate directions and values of forces transmitted to the structure during seismic events.
 - c. Preapproval and Evaluation Documentation: By an evaluation service member of ICC-ES, showing maximum ratings of restraint items and the basis for approval (tests or calculations).

1.6 INFORMATIONAL SUBMITTALS

- A. Coordination Drawings: Show coordination of seismic bracing for electrical components with other systems and equipment in the vicinity, including other supports and seismic restraints.
- B. Qualification Data: For professional engineer.
- C. Welding certificates.
- D. Field quality-control test reports.

1.7 QUALITY ASSURANCE

- A. Testing Agency Qualifications: An independent agency, with the experience and capability to conduct the testing indicated, that is a nationally recognized testing laboratory (NRTL) as defined by OSHA in 29 CFR 1910.7, and that is acceptable to authorities having jurisdiction.
- B. Comply with seismic-restraint requirements in the IBC unless requirements in this Section are more stringent.
- C. Welding: Qualify procedures and personnel according to AWS D1.1/D1.1M, "Structural Welding Code - Steel."
- D. Comply with NFPA 70.

PART 2 - PRODUCTS

2.1 VIBRATION ISOLATORS

- A. Available Manufacturers: Subject to compliance with requirements, manufacturers offering products that may be incorporated into the Work include, but are not limited to, the following:
 1. Ace Mountings Co., Inc.
 2. Amber/Booth Company, Inc.
 3. California Dynamics Corporation.
 4. Isolation Technology, Inc.
 5. Kinetics Noise Control.
 6. Mason Industries.
 7. Vibration Eliminator Co., Inc.
 8. Vibration Isolation.
 9. Vibration Mountings & Controls, Inc.
- B. Spring Isolators: Freestanding, laterally stable, open-spring isolators.
 1. Outside Spring Diameter: Not less than 80 percent of the compressed height of the spring at rated load.
 2. Minimum Additional Travel: 50 percent of the required deflection at rated load.
 3. Lateral Stiffness: More than 80 percent of rated vertical stiffness.

4. Overload Capacity: Support 200 percent of rated load, fully compressed, without deformation or failure.
 5. Baseplates: Factory drilled for bolting to structure and bonded to 1/4-inch- (6-mm-) thick, rubber isolator pad attached to baseplate underside. Baseplates shall limit floor load to 500 psig (3447 kPa).
 6. Top Plate and Adjustment Bolt: Threaded top plate with adjustment bolt and cap screw to fasten and level equipment.
- C. Restrained Spring Isolators: Freestanding, steel, open-spring isolators with seismic or limit-stop restraint.
1. Housing: Steel with resilient vertical-limit stops to prevent spring extension due to weight being removed; factory-drilled baseplate bonded to 1/4-inch- (6-mm-) thick, neoprene or rubber isolator pad attached to baseplate underside; and adjustable equipment mounting and leveling bolt that acts as blocking during installation.
 2. Restraint: Seismic or limit-stop as required for equipment and authorities having jurisdiction.
 3. Outside Spring Diameter: Not less than 80 percent of the compressed height of the spring at rated load.
 4. Minimum Additional Travel: 50 percent of the required deflection at rated load.
 5. Lateral Stiffness: More than 80 percent of rated vertical stiffness.
 6. Overload Capacity: Support 200 percent of rated load, fully compressed, without deformation or failure.

2.2 SEISMIC-RESTRAINT DEVICES

- A. Available Manufacturers: Subject to compliance with requirements, manufacturers offering products that may be incorporated into the Work include, but are not limited to, the following:
1. Amber/Booth Company, Inc.
 2. California Dynamics Corporation.
 3. Cooper B-Line, Inc.; a division of Cooper Industries.
 4. Hilti Inc.
 5. Loos & Co.; Seismic Earthquake Division.
 6. Mason Industries.
 7. TOLCO Incorporated; a brand of NIBCO INC.
 8. Unistrut; Tyco International, Ltd.
- B. General Requirements for Restraint Components: Rated strengths, features, and application requirements shall be as defined in reports by an evaluation service member of ICC-ES.
1. Structural Safety Factor: Allowable strength in tension, shear, and pullout force of components shall be at least four times the maximum seismic forces to which they will be subjected.
- C. Channel Support System: MFMA-3, shop- or field-fabricated support assembly made of slotted steel channels with accessories for attachment to braced component at one end and to building structure at the other end and other matching components and with corrosion-resistant coating; and rated in tension, compression, and torsion forces.
- D. Restraint Cables: ASTM A 492 stainless-steel cables with end connections made of steel assemblies with thimbles, brackets, swivels, and bolts designed for restraining cable service; and with a minimum of two clamping bolts for cable engagement.
- E. Hanger Rod Stiffener: Steel tube or steel slotted-support-system sleeve with internally bolted connections to hanger rod. Do not weld stiffeners to rods.
- F. Bushings for Floor-Mounted Equipment Anchor: Neoprene bushings designed for rigid equipment mountings, and matched to type and size of anchors and studs.
- G. Bushing Assemblies for Wall-Mounted Equipment Anchorage: Assemblies of neoprene elements and steel sleeves designed for rigid equipment mountings, and matched to type and size of attachment devices.

- H. Resilient Isolation Washers and Bushings: One-piece, molded, oil- and water-resistant neoprene, with a flat washer face.
- I. Mechanical Anchor: Drilled-in and stud-wedge or female-wedge type in zinc-coated steel for interior applications and stainless steel for exterior applications. Select anchors with strength required for anchor and as tested according to ASTM E 488. Minimum length of eight times diameter.
- J. Adhesive Anchor: Drilled-in and capsule anchor system containing polyvinyl or urethane methacrylate-based resin and accelerator, or injected polymer or hybrid mortar adhesive. Provide anchor bolts and hardware with zinc-coated steel for interior applications and stainless steel for exterior applications. Select anchor bolts with strength required for anchor and as tested according to ASTM E 488.

2.3 FACTORY FINISHES

- A. Finish: Manufacturer's standard prime-coat finish ready for field painting.
- B. Finish: Manufacturer's standard paint applied to factory-assembled and -tested equipment before shipping.
 - 1. Powder coating on springs and housings.
 - 2. All hardware shall be galvanized. Hot-dip galvanize metal components for exterior use.
 - 3. Baked enamel or powder coat for metal components on isolators for interior use.
 - 4. Color-code or otherwise mark vibration isolation and seismic-control devices to indicate capacity range.

PART 3 - EXECUTION

3.1 EXAMINATION

- A. Examine areas and equipment to receive vibration isolation and seismic-control devices for compliance with requirements for installation tolerances and other conditions affecting performance.
- B. Examine roughing-in of reinforcement and cast-in-place anchors to verify actual locations before installation.
- C. Proceed with installation only after unsatisfactory conditions have been corrected.

3.2 APPLICATIONS

- A. Multiple Raceways or Cables: Secure raceways and cables to trapeze member with clamps approved for application by an evaluation service member of ICC-ES.
- B. Hanger Rod Stiffeners: Install hanger rod stiffeners where indicated or scheduled on Drawings to receive them and where required to prevent buckling of hanger rods due to seismic forces.
- C. Strength of Support and Seismic-Restraint Assemblies: Where not indicated, select sizes of components so strength will be adequate to carry present and future static and seismic loads within specified loading limits.

3.3 SEISMIC-RESTRAINT DEVICE INSTALLATION

- A. Equipment and Hanger Restraints:
 - 1. Install restrained isolators on electrical equipment.
 - 2. Install resilient, bolt-isolation washers on equipment anchor bolts where clearance between anchor and adjacent surface exceeds 0.125 inch (3.2 mm).
 - 3. Install seismic-restraint devices using methods approved by an evaluation service member of ICC-ES providing required submittals for component.
- B. Install bushing assemblies for mounting bolts for wall-mounted equipment, arranged to provide resilient media where equipment or equipment-mounting channels are attached to wall.
- C. Attachment to Structure: If specific attachment is not indicated, anchor bracing to structure at flanges of beams, at upper truss chords of bar joists, or at concrete members.
- D. Drilled-in Anchors:

1. Identify position of reinforcing steel and other embedded items prior to drilling holes for anchors. Do not damage existing reinforcing or embedded items during coring or drilling. Notify the structural engineer if reinforcing steel or other embedded items are encountered during drilling. Locate and avoid prestressed tendons, electrical and telecommunications conduit, and gas lines.
2. Do not drill holes in concrete or masonry until concrete, mortar, or grout has achieved full design strength.
3. Wedge Anchors: Protect threads from damage during anchor installation. Heavy-duty sleeve anchors shall be installed with sleeve fully engaged in the structural element to which anchor is to be fastened.
4. Adhesive Anchors: Clean holes to remove loose material and drilling dust prior to installation of adhesive. Place adhesive in holes proceeding from the bottom of the hole and progressing toward the surface in such a manner as to avoid introduction of air pockets in the adhesive.
5. Set anchors to manufacturer's recommended torque, using a torque wrench.
6. Install zinc-coated steel anchors for interior and stainless-steel anchors for exterior applications.

3.4 ACCOMMODATION OF DIFFERENTIAL SEISMIC MOTION

- A. Install flexible connections in runs of raceways, cables, wireways, cable trays, and busways where they cross seismic joints, where adjacent sections or branches are supported by different structural elements, and where they terminate with connection to equipment that is anchored to a different structural element from the one supporting them as they approach equipment.

3.5 FIELD QUALITY CONTROL

- A. Perform tests and inspections.
- B. Tests and Inspections:
 1. Provide evidence of recent calibration of test equipment by a testing agency acceptable to authorities having jurisdiction.
 2. Schedule test with Owner, through Architect, before connecting anchorage device to restrained component (unless postconnection testing has been approved), and with at least seven days' advance notice.
 3. Obtain Architect's approval before transmitting test loads to structure. Provide temporary load-spreading members.
 4. Test at least four of each type and size of installed anchors and fasteners selected by Architect.
 5. Test to 90 percent of rated proof load of device.
 6. Measure isolator restraint clearance.
 7. Measure isolator deflection.
 8. Verify snubber minimum clearances.
 9. If a device fails test, modify all installations of same type and retest until satisfactory results are achieved.
- C. Remove and replace malfunctioning units and retest as specified above.
- D. Prepare test and inspection reports.

3.6 ADJUSTING

- A. Adjust isolators after isolated equipment is at operating weight.
- B. Adjust limit stops on restrained spring isolators to mount equipment at normal operating height. After equipment installation is complete, adjust limit stops so they are out of contact during normal operation.
- C. Adjust active height of spring isolators.
- D. Adjust restraints to permit free movement of equipment within normal mode of operation.

END OF SECTION

SECTION 26 0553

IDENTIFICATION FOR ELECTRICAL SYSTEMS

PART 1 - GENERAL

1.1 RELATED DOCUMENTS

- A. Drawings and general provisions of the Contract, including General and Supplementary Conditions and Division 01 Specification Sections, apply to this Section.

1.2 SUMMARY

- A. Section Includes:
 1. Identification for raceways.
 2. Identification of power and control cables.
 3. Identification for conductors.
 4. Underground-line warning tape.
 5. Warning labels and signs.
 6. Instruction signs.
 7. Equipment identification labels.
 8. Miscellaneous identification products.

1.3 ACTION SUBMITTALS

- A. Product Data: For each electrical identification product indicated.
- B. Samples: For each type of label and sign to illustrate size, colors, lettering style, mounting provisions, and graphic features of identification products.
- C. Identification Schedule: An index of nomenclature of electrical equipment and system components used in identification signs and labels.

1.4 QUALITY ASSURANCE

- A. Comply with ANSI A13.1 and IEEE C2.
- B. Comply with NFPA 70.
- C. Comply with 29 CFR 1910.144 and 29 CFR 1910.145.
- D. Comply with ANSI Z535.4 for safety signs and labels.
- E. Adhesive-attached labeling materials, including label stocks, laminating adhesives, and inks used by label printers, shall comply with UL 969.

1.5 COORDINATION

- A. Coordinate identification names, abbreviations, colors, and other features with requirements in other Sections requiring identification applications, Drawings, Shop Drawings, manufacturer's wiring diagrams, and the Operation and Maintenance Manual; and with those required by codes, standards, and 29 CFR 1910.145. Use consistent designations throughout Project.
- B. Coordinate installation of identifying devices with completion of covering and painting of surfaces where devices are to be applied.
- C. Coordinate installation of identifying devices with location of access panels and doors.
- D. Install identifying devices before installing acoustical ceilings and similar concealment.

PART 2 - PRODUCTS

2.1 POWER AND CONTROL RACEWAY IDENTIFICATION MATERIALS

- A. Color coded raceways with factory applied color coating.

- B. Colors for Raceways:
 - 1. Normal power circuits: no added color.
 - 2. Emergency power circuits: blue
 - 3. Optional Standby and UPS power circuits: green
 - 4. Fire Alarm wiring: red
 - 5. Access control and CCTV systems wiring: white
 - 6. All other systems: black

2.2 ARMORED AND METAL-CLAD CABLE IDENTIFICATION MATERIALS

- A. Comply with ANSI A13.1 for minimum size of letters for legend and for minimum length of color field for each cable size.
- B. Colors for Cables Carrying Circuits at 600 V and Less:
 - 1. Black letters on an orange field.
 - 2. Legend: Indicate voltage and system or service type.
- C. Heat-Shrink Preprinted Tubes: Flame-retardant polyolefin tube with machine-printed identification label. Sized to suit diameter of and shrinks to fit firmly around cable it identifies. Full shrink recovery at a maximum of **200 deg F (93 deg C)**. Comply with UL 224.

2.3 POWER AND CONTROL CABLE IDENTIFICATION MATERIALS

- A. Comply with ANSI A13.1 for minimum size of letters for legend and for minimum length of color field for each cable size.
- B. Snap-Around Labels: Slit, pretensioned, flexible, preprinted, color-coded acrylic sleeve, with diameter sized to suit diameter of cable it identifies and to stay in place by gripping action.

2.4 CONDUCTOR IDENTIFICATION MATERIALS

- A. Color-Coding Conductor Tape: Colored, self-adhesive vinyl tape not less than **3 mils (0.08 mm)** thick by **1 to 2 inches (25 to 50 mm)** wide.
- B. Snap-Around Labels: Slit, pretensioned, flexible, preprinted, color-coded acrylic sleeve, with diameter sized to suit diameter of conductor it identifies and to stay in place by gripping action.

2.5 FLOOR MARKING TAPE

- A. **2-inch- (50-mm-)** wide, **5-mil (0.125-mm)** pressure-sensitive vinyl tape, with yellow and black stripes and clear vinyl overlay.

2.6 UNDERGROUND-LINE WARNING TAPE

- A. Tape:
 - 1. Recommended by manufacturer for the method of installation and suitable to identify and locate underground electrical and communications utility lines.
 - 2. Printing on tape shall be permanent and shall not be damaged by burial operations.
 - 3. Tape material and ink shall be chemically inert, and not subject to degrading when exposed to acids, alkalis, and other destructive substances commonly found in soils.
- B. Color and Printing:
 - 1. Comply with ANSI Z535.1 through ANSI Z535.5.
 - 2. Inscriptions for Red-Colored Tapes: **ELECTRIC LINE, HIGH VOLTAGE,**.
 - 3. Inscriptions for Orange-Colored Tapes: **TELEPHONE CABLE, CATV CABLE, COMMUNICATIONS CABLE, OPTICAL FIBER CABLE,**.

2.7 WARNING LABELS AND SIGNS

- A. Comply with NFPA 70 and 29 CFR 1910.145.
- B. Metal-Backed, Butyrate Warning Signs:
 - 1. Weather-resistant, nonfading, preprinted, cellulose-acetate butyrate signs with **0.0396-inch (1-mm)** galvanized-steel backing; and with colors, legend, and size required for application.
 - 2. **1/4-inch (6.4-mm)** grommets in corners for mounting.

3. Nominal size, 10 by 14 inches (250 by 360 mm).
- C. Warning label and sign shall include, but are not limited to, the following legends:
1. Multiple Power Source Warning: "DANGER - ELECTRICAL SHOCK HAZARD - EQUIPMENT HAS MULTIPLE POWER SOURCES."
 2. Workspace Clearance Warning: "WARNING - OSHA REGULATION - AREA IN FRONT OF ELECTRICAL EQUIPMENT MUST BE KEPT CLEAR FOR 36 INCHES (915 MM)."

2.8 INSTRUCTION SIGNS

- A. Engraved, laminated acrylic or melamine plastic, minimum 1/16 inch (1.6 mm) thick for signs up to 20 sq. inches (129 sq. cm) and 1/8 inch (3.2 mm) thick for larger sizes.
1. Engraved legend with black letters on white face.
 2. Punched or drilled for mechanical fasteners.
 3. Framed with mitered acrylic molding and arranged for attachment at applicable equipment.

2.9 EQUIPMENT IDENTIFICATION LABELS

- A. Engraved, Laminated Acrylic or Melamine Label: Punched or drilled for screw mounting. White letters on a dark-gray background. Minimum letter height shall be 3/8 inch (10 mm).

2.10 MISCELLANEOUS IDENTIFICATION PRODUCTS

- A. Paint: Comply with requirements in painting Sections for paint materials and application requirements. Select paint system applicable for surface material and location (exterior or interior).
- B. Fasteners for Labels and Signs: Self-tapping, stainless-steel screws or stainless-steel machine screws with nuts and flat and lock washers.

PART 3 - EXECUTION

3.1 INSTALLATION

- A. Verify identity of each item before installing identification products.
- B. Location: Install identification materials and devices at locations for most convenient viewing without interference with operation and maintenance of equipment.
- C. Apply identification devices to surfaces that require finish after completing finish work.
- D. Self-Adhesive Identification Products: Clean surfaces before application, using materials and methods recommended by manufacturer of identification device.
- E. Attach signs and plastic labels that are not self-adhesive type with mechanical fasteners appropriate to the location and substrate.
- F. Attach plastic raceway and cable labels that are not self-adhesive type with clear vinyl tape with adhesive appropriate to the location and substrate.
- G. System Identification Color-Coding Bands for Raceways and Cables: Each color-coding band shall completely encircle cable or conduit. Place adjacent bands of two-color markings in contact, side by side. Locate bands at changes in direction, at penetrations of walls and floors, at 50-foot (15-m) maximum intervals in straight runs, and at 25-foot (7.6-m) maximum intervals in congested areas.
- H. Aluminum Wraparound Marker Labels and Metal Tags: Secure tight to surface of conductor or cable at a location with high visibility and accessibility.
- I. Cable Ties: For attaching tags. Use general-purpose type, except as listed below:
1. Outdoors: UV-stabilized nylon.
 2. In Spaces Handling Environmental Air: Plenum rated.
- J. Underground-Line Warning Tape: During backfilling of trenches install continuous underground-line warning tape directly above line at 6 to 8 inches (150 to 200 mm) below finished grade. Use multiple tapes where width of multiple lines installed in a common trench or concrete envelope exceeds 16 inches (400 mm) overall.

- K. Painted Identification: Comply with requirements in painting Sections for surface preparation and paint application.

3.2 IDENTIFICATION SCHEDULE

- A. Accessible Raceways and Cables within Buildings: Identify the covers of each junction and pull box of the following systems with color coding that matches raceways and self-adhesive vinyl labels with the wiring system legend. For power circuits include the panel and circuit numbers of all conductors contained in the box and the voltage. For fire alarm circuits include the circuit numbering to match shop drawings. For other systems include the system type such as Access Control, CCTV, Overhead Paging, etc. System color coding shall be as follows:
 - 1. Normal power circuits: no added color.
 - 2. Emergency power circuits: blue
 - 3. Optional Standby and UPS power circuits: green
 - 4. Fire Alarm wiring: red
 - 5. Access control and CCTV systems wiring: white
 - 6. All other systems: black
- B. Power-Circuit Conductor Identification, 600 V or Less: For conductors in vaults, pull and junction boxes, manholes, and handholes, use color-coding conductor tape to identify the phase.
 - 1. Color-Coding for Phase and Voltage Level Identification, 600 V or Less: Use colors listed below for ungrounded service, feeder, and branch-circuit conductors.
 - a. Color shall be factory applied.
 - b. Colors for 208/120-V Circuits:
 - 1) Phase A: Black.
 - 2) Phase B: Red.
 - 3) Phase C: Blue.
 - c. Colors for 480/277-V Circuits:
 - 1) Phase A: Orange
 - 2) Phase B: Brown
 - 3) Phase C: Yellow.
- C. Install instructional sign including the color-code for grounded and ungrounded conductors using adhesive- vinyl-film-type labels.
- D. Control-Circuit Conductor Identification: For conductors and cables in pull and junction boxes, manholes, and handholes, use self-adhesive vinyl labels with the conductor or cable designation, origin, and destination.
- E. Conductors to Be Extended in the Future: Attach marker tape to conductors and list source.
- F. Auxiliary Electrical Systems Conductor Identification: Identify field-installed alarm, control, and signal connections.
 - 1. Identify conductors, cables, and terminals in enclosures and at junctions, terminals, and pull points. Identify by system and circuit designation.
 - 2. Use system of marker tape designations that is uniform and consistent with system used by manufacturer for factory-installed connections.
 - 3. Coordinate identification with Project Drawings, manufacturer's wiring diagrams, and the Operation and Maintenance Manual.
- G. Locations of Underground Lines: Identify with underground-line warning tape for power, lighting, communication, and control wiring and optical fiber cable.
 - 1. Limit use of underground-line warning tape to direct-buried cables.
 - 2. Install underground-line warning tape for both direct-buried cables and cables in raceway.
- H. Workspace Indication: Install floor marking tape to show working clearances in the direction of access to live parts. Workspace shall be as required by NFPA 70 and 29 CFR 1926.403 unless otherwise indicated. Do not install at flush-mounted panelboards and similar equipment in finished spaces.
- I. Warning Labels for Indoor Cabinets, Boxes, and Enclosures for Power and Lighting: Self-adhesive warning labels.

1. Comply with 29 CFR 1910.145.
 2. Identify system voltage with black letters on an orange background.
 3. Apply to exterior of door, cover, or other access.
 4. For equipment with multiple power or control sources, apply to door or cover of equipment including, but not limited to, the following:
 - a. Power transfer switches.
 - b. Controls with external control power connections.
- J. Operating Instruction Signs: Install instruction signs to facilitate proper operation and maintenance of electrical systems and items to which they connect. Install instruction signs with approved legend where instructions are needed for system or equipment operation.
- K. Emergency Operating Instruction Signs: Install instruction signs with white legend on a red background with minimum **3/8-inch- (10-mm-)** high letters for emergency instructions at equipment used for power transfer.
- L. Equipment Identification Labels: On each unit of equipment, install unique designation label that is consistent with wiring diagrams, schedules, and the Operation and Maintenance Manual. Apply labels to disconnect switches and protection equipment, central or master units, control panels, control stations, terminal cabinets, and racks of each system. Systems include power, lighting, control, communication, signal, monitoring, and alarm systems unless equipment is provided with its own identification.
1. Labeling Instructions:
 - a. Indoor Equipment: Engraved, laminated acrylic or melamine label. Unless otherwise indicated, provide a single line of text with **1/2-inch- (13-mm-)** high letters on **1-1/2-inch- (38-mm-)** high label; where two lines of text are required, use labels **2 inches (50 mm)** high.
 - b. Outdoor Equipment: Engraved, laminated acrylic or melamine label.
 - c. Elevated Components: Increase sizes of labels and letters to those appropriate for viewing from the floor.
 - d. Fasten labels with appropriate mechanical fasteners that do not change the NEMA or NRTL rating of the enclosure.
 2. Equipment to Be Labeled:
 - a. Panelboards: Typewritten directory of circuits in the location provided by panelboard manufacturer. Panelboard identification shall be engraved, laminated acrylic or melamine label.
 - b. All receptacles and switches
 - c. Fire alarm devices
 - d. Circuit #'s on j-boxes
 - e. Enclosures and electrical cabinets.
 - f. Access doors and panels for concealed electrical items.
 - g. Switchboards.
 - h. Transformers: Label that includes tag designation shown on Drawings for the transformer, feeder, and panelboards or equipment supplied by the secondary.
 - i. Emergency system boxes and enclosures.
 - j. Enclosed switches.
 - k. Enclosed circuit breakers.
 - l. Enclosed controllers.
 - m. Variable-speed controllers.
 - n. Push-button stations.
 - o. Power transfer equipment.
 - p. Contactors.
 - q. Remote-controlled switches, dimmer modules, and control devices.
 - r. Battery racks.
 - s. Monitoring and control equipment.
 - t. UPS equipment.

END OF SECTION

SECTION 26 0923

LIGHTING CONTROL DEVICES

PART 1 - GENERAL

1.1 RELATED DOCUMENTS

- A. Drawings and general provisions of the Contract, including General and Supplementary Conditions and Division 01 Specification Sections, apply to this Section.

1.2 SUMMARY

- A. Section Includes:
 - 1. Indoor occupancy sensors.
 - 2. Indoor vacancy sensors.
- B. Related Requirements:
 - 1. Section 262726 "Wiring Devices" for wall-box dimmers, wall-switch occupancy sensors, and manual light switches.
 - 2. 019113 – GENERAL COMMISSIONING REQUIREMENTS
 - 3. 260800 – COMMISSIONING ELECTRICAL SYSTEMS

1.3 ACTION SUBMITTALS

- A. Product Data: For each type of product.

1.4 INFORMATIONAL SUBMITTALS

- A. Field quality-control reports.

1.5 CLOSEOUT SUBMITTALS

- A. Operation and Maintenance Data: For each type of lighting control device to include in emergency, operation, and maintenance manuals.

PART 2 - PRODUCTS

2.1 INDOOR CEILING MOUNTED OCCUPANCY SENSORS

- A. General Requirements for Sensors: Ceiling-mounted, solid-state indoor occupancy sensors with a separate power pack.
 - 1. Listed and labeled as defined in NFPA 70, by a qualified testing agency, and marked for intended location and application.

2. Operation: Unless otherwise indicated, turn lights on when coverage area is occupied, and turn them off when unoccupied; with a time delay for turning lights off, adjustable over a minimum range of 1 to 15 minutes.
 3. Sensor Output: Contacts rated to operate the connected relay, complying with UL 773A. Sensor is powered from the power pack.
 4. Power Pack: Dry contacts rated for 20-A ballast load at 120- and 277-V ac, for 13-A tungsten at 120-V ac, and for 1 hp at 120-V ac. Sensor has 24-V dc, 150-mA, Class 2 power source, as defined by NFPA 70.
 5. Mounting:
 - a. Sensor: Suitable for mounting in any position on a standard outlet box.
 - b. Relay: Externally mounted through a 1/2-inch (13-mm) knockout in a standard electrical enclosure.
 - c. Time-Delay and Sensitivity Adjustments: Recessed and concealed behind hinged door.
 6. Indicator: Digital display, to show when motion is detected during testing and normal operation of sensor.
 7. Bypass Switch: Override the "on" function in case of sensor failure.
 8. Automatic Light-Level Sensor: Adjustable from 2 to 200 fc (21.5 to 2152 lux); turn lights off when selected lighting level is present.
 9. Provide auxiliary isolated form C relay for HVAC tracking control. VAV controls will connect to auxiliary contacts.
- B. Dual-Technology Type: Ceiling mounted; detect occupants in coverage area using PIR and ultrasonic detection methods. The particular technology or combination of technologies that control on-off functions is selectable in the field by operating controls on unit.
1. Sensitivity Adjustment: Separate for each sensing technology.
 2. Detector Sensitivity: Detect occurrences of 6-inch- (150-mm-) minimum movement of any portion of a human body that presents a target of not less than 36 sq. in. (232 sq. cm), and detect a person of average size and weight moving not less than 12 inches (305 mm) in either a horizontal or a vertical manner at an approximate speed of 12 inches/s (305 mm/s).
 3. Detection Coverage (Standard Room): Detect occupancy anywhere within a circular area of 1000 sq. ft. (93 sq. m) when mounted on a 96-inch- (2440-mm-) high ceiling.
 4. Provide auxiliary isolated form C relay for HVAC tracking control. VAV controls will connect to auxiliary contacts.

2.2 INDOOR CEILING MOUNTED VACANCY SENSORS

- A. General Requirements for Sensors: Ceiling-mounted, solid-state indoor occupancy sensors with a separate power pack.
1. Listed and labeled as defined in NFPA 70, by a qualified testing agency, and marked for intended location and application.
 2. Receives input from momentary contact wall switch to turn on lights.
 3. Operation: Turn lights on when momentary contact switch is closed, and turn them off when unoccupied; with a time delay for turning lights off, adjustable over a minimum range of 1 to 15 minutes.
 4. Sensor Output: Contacts rated to operate the connected relay, complying with UL 773A. Sensor is powered from the power pack.
 5. Power Pack: Dry contacts rated for 20-A ballast load at 120- and 277-V ac, for 13-A tungsten at 120-V ac, and for 1 hp at 120-V ac. Sensor has 24-V dc, 150-mA, Class 2 power source, as defined by NFPA 70.
 6. Mounting:
 - a. Sensor: Suitable for mounting in any position on a standard outlet box.
 - b. Relay: Externally mounted through a 1/2-inch (13-mm) knockout in a standard electrical enclosure.

- c. Time-Delay and Sensitivity Adjustments: Recessed and concealed behind hinged door.
 - 7. Indicator: Digital display, to show when motion is detected during testing and normal operation of sensor.
 - 8. Bypass Switch: Override the "on" function in case of sensor failure.
 - 9. Automatic Light-Level Sensor: Adjustable from 2 to 200 fc (21.5 to 2152 lux); turn lights off when selected lighting level is present.
 - 10. Provide vacancy sensor with a isolated Form C relay (HVAC/TRACKING) mode.
 - a. Manual Mode (-R Model Only) In Manual ON Mode, the optional momentary low voltage switch(es) is required to turn the load(s) ON. Once activated the sensor will maintain the lights ON until motion ceases and the time delay expires. While the room is occupied the BAS relay remains active. After the Time Delay expires, the load(s) will automatically be turned OFF and the switch(es) must be used to turn the load(s) ON unless there is motion detected within the 10 second re-trigger period.
 - b. HVAC/Tracking Mode (-R model only) If selected, Tracking Mode allows the load connection to the Form C relay to follow the state of the sensor's blue lead. HVAC Mode allows the load connected to the Form C relay to remain ON when the lights are turned OFF manually. Applications may include keeping the room at a desired temperature while giving a presentation and the lights are OFF.
- B. Dual-Technology Type: Ceiling mounted; detect occupants in coverage area using PIR and ultrasonic detection methods. The particular technology or combination of technologies that control on-off functions is selectable in the field by operating controls on unit.
- 1. Sensitivity Adjustment: Separate for each sensing technology.
 - 2. Detector Sensitivity: Detect occurrences of 6-inch- (150-mm-) minimum movement of any portion of a human body that presents a target of not less than 36 sq. in. (232 sq. cm), and detect a person of average size and weight moving not less than 12 inches (305 mm) in either a horizontal or a vertical manner at an approximate speed of 12 inches/s (305 mm/s).
 - 3. Detection Coverage (Standard Room): Detect occupancy anywhere within a circular area of 1000 sq. ft. (93 sq. m) when mounted on a 96-inch- (2440-mm-) high ceiling.
 - 4. Provide vacancy sensor with a isolated Form C relay (HVAC/TRACKING) mode.
 - a. Manual Mode (-R Model Only) In Manual ON Mode, the optional momentary low voltage switch(es) is required to turn the load(s) ON. Once activated the sensor will maintain the lights ON until motion ceases and the time delay expires. While the room is occupied the BAS relay remains active. After the Time Delay expires, the load(s) will automatically be turned OFF and the switch(es) must be used to turn the load(s) ON unless there is motion detected within the 10 second re-trigger period.
 - b. HVAC/Tracking Mode (-R model only) If selected, Tracking Mode allows the load connection to the Form C relay to follow the state of the sensor's blue lead. HVAC Mode allows the load connected to the Form C relay to remain ON when the lights are turned OFF manually. Applications may include keeping the room at a desired temperature while giving a presentation and the lights are OFF.
 - 5.

2.3 SWITCHBOX-MOUNTED OCCUPANCY SENSORS

- A. General Requirements for Sensors: Automatic-wall-switch occupancy sensor, suitable for mounting in a single gang switchbox.
 - 1. Listed and labeled as defined in NFPA 70, by a qualified testing agency, and marked for intended location and application.
 - 2. Operating Ambient Conditions: Dry interior conditions, 32 to 120 deg F (0 to 49 deg C).

3. Switch Rating: Not less than 800-VA fluorescent at 120 V, 1200-VA fluorescent at 277 V, and 800-W incandescent.
- B. Wall-Switch Sensor:
1. Standard Range: 210-degree field of view, with a minimum coverage area of 900 sq. ft. (84 sq. m).
 2. Sensing Technology: PIR.
 3. Switch Type: SP, field selectable automatic "on," or manual "on" automatic "off."
 4. Voltage: Match the circuit voltage; dual-technology type.
 5. Ambient-Light Override: Concealed, field-adjustable, light-level sensor from 10 to 150 fc (108 to 1600 lux). The switch prevents the lights from turning on when the light level is higher than the set point of the sensor.
 6. Concealed, field-adjustable, "off" time-delay selector at up to 30 minutes.
 7. Concealed "off" time-delay selector at 30 seconds, and 5, 10, and 20 minutes.
 8. Adaptive Technology: Self-adjusting circuitry detects and memorizes usage patterns of the space and helps eliminate false "off" switching.

2.4 SWITCHBOX-MOUNTED VACANCY SENSORS

- A. General Requirements for Sensors: Automatic-wall-switch occupancy sensor, suitable for mounting in a single gang switchbox.
1. Listed and labeled as defined in NFPA 70, by a qualified testing agency, and marked for intended location and application.
 2. Operating Ambient Conditions: Dry interior conditions, 32 to 120 deg F (0 to 49 deg C).
 3. Switch Rating: Not less than 800-VA fluorescent at 120 V, 1200-VA fluorescent at 277 V, and 800-W incandescent.
- B. Wall-Switch Sensor:
1. Standard Range: 210-degree field of view, with a minimum coverage area of 900 sq. ft. (84 sq. m).
 2. Sensing Technology: PIR.
 3. Switch Type: SP, manual "on," automatic "off."
 4. Voltage: Match the circuit voltage; dual-technology type.
 5. Ambient-Light Override: Concealed, field-adjustable, light-level sensor from 10 to 150 fc (108 to 1600 lux). The switch prevents the lights from turning on when the light level is higher than the set point of the sensor.
 6. Concealed, field-adjustable, "off" time-delay selector at up to 30 minutes.
 7. Concealed "off" time-delay selector at 30 seconds, and 5, 10, and 20 minutes.
Adaptive Technology: Self-adjusting circuitry detects and memorizes usage patterns of the space and helps eliminate false "off" switching

PART 3 - EXECUTION

3.1 SENSOR INSTALLATION

- A. Coordinate layout and installation of ceiling-mounted devices with other construction that penetrates ceilings or is supported by them, including light fixtures, HVAC equipment, smoke detectors, fire-suppression systems, and partition assemblies.
- B. Install and aim sensors in locations to achieve not less than 90 percent coverage of areas indicated. Do not exceed coverage limits specified in manufacturer's written instructions.

3.2 CONTACTOR INSTALLATION

- A. Mount electrically held lighting contactors with elastomeric isolator pads to eliminate structure-borne vibration, unless contactors are installed in an enclosure with factory-installed vibration isolators.

3.3 WIRING INSTALLATION

- A. Wiring Method: Comply with Section 260519 "Low-Voltage Electrical Power Conductors and Cables." Minimum conduit size is **1/2 inch (13 mm)**.
- B. Wiring within Enclosures: Comply with NECA 1. Separate power-limited and nonpower-limited conductors according to conductor manufacturer's written instructions.
- C. Size conductors according to lighting control device manufacturer's written instructions unless otherwise indicated.
- D. Splices, Taps, and Terminations: Make connections only on numbered terminal strips in junction, pull, and outlet boxes; terminal cabinets; and equipment enclosures.

3.4 IDENTIFICATION

- A. Identify components and power and control wiring according to Section 260553 "Identification for Electrical Systems."
 - 1. Identify controlled circuits in lighting contactors.
 - 2. Identify circuits or luminaires controlled by photoelectric and occupancy sensors at each sensor.
- B. Label time switches and contactors with a unique designation.

3.5 FIELD QUALITY CONTROL

- A. Perform the following tests and inspections[with the assistance of a factory-authorized service representative]:
 - 1. Operational Test: After installing time switches and sensors, and after electrical circuitry has been energized, start units to confirm proper unit operation.
 - 2. Test and adjust controls and safeties. Replace damaged and malfunctioning controls and equipment.
- B. Lighting control devices will be considered defective if they do not pass tests and inspections.
- C. Prepare test and inspection reports.

3.6 ADJUSTING

- A. Occupancy Adjustments: When requested within 2 months from date of Substantial Completion, provide on-site assistance in adjusting sensors to suit actual occupied conditions. Provide up to two visits to Project during other-than-normal occupancy hours for this purpose.
 - 1. For occupancy and motion sensors, verify operation at outer limits of detector range. Set time delay to suit Owner's operations.

2. For daylighting controls, adjust set points and deadband controls to suit Owner's operations.

END OF SECTION

SECTION 26 27 26
WIRING DEVICES

PART 1 - GENERAL

1.1 RELATED DOCUMENTS

- A. Drawings and general provisions of the Contract, including General and Supplementary Conditions and Division 01 Specification Sections, apply to this Section.

1.2 SUMMARY

- A. Section Includes:
 - 1. Receptacles, receptacles with integral GFCI, and associated device plates.
 - 2. Twist-locking receptacles.
 - 3. USB charger devices.
 - 4. Isolated-ground receptacles.
 - 5. Hospital-grade receptacles.
 - 6. Tamper-resistant receptacles.
 - 7. Weather-resistant receptacles.
 - 8. Snap switches and wall-box dimmers.
 - 9. Floor service outlets (floor boxes) and poke-through assemblies.
 - 10. Pendant Cord Connector Devices (Drop Cords).
 - 11. Cord Reels

1.3 DEFINITIONS

- A. EMI: Electromagnetic interference.
- B. GFCI: Ground-fault circuit interrupter.
- C. Pigtail: Short lead used to connect a device to a branch-circuit conductor.
- D. RFI: Radio-frequency interference.

1.4 ADMINISTRATIVE REQUIREMENTS

- A. Coordination:
 - 1. Receptacles for Owner-Furnished Equipment: Match plug configurations.
 - 2. Cord and Plug Sets: Match equipment requirements.

1.5 ACTION SUBMITTALS

- A. Product Data: For each type of product.

1.6 INFORMATIONAL SUBMITTALS

- A. Field quality-control reports.

1.7 CLOSEOUT SUBMITTALS

- A. Operation and Maintenance Data: For wiring devices to include in all manufacturers' packing-label warnings and instruction manuals that include labeling conditions.

PART 2 - PRODUCTS

2.1 MANUFACTURERS

- A. Manufacturers: Subject to compliance with requirements, provide products by one of the following:
 - 1. Eaton (Arrow Hart).
 - 2. Hubbell Incorporated; Wiring Device-Kellems.
 - 3. Leviton Manufacturing Co., Inc.
 - 4. Pass & Seymour/Legrand (Pass & Seymour).
- B. Source Limitations: Obtain each type of wiring device and associated wall plate from single source from single manufacturer.

2.2 GENERAL WIRING-DEVICE REQUIREMENTS

- A. Wiring Devices, Components, and Accessories: Listed and labeled as defined in NFPA 70, by a qualified testing agency, and marked for intended location and application.
- B. Comply with NFPA 70.
- C. All devices must be manufactured for use with modular plug-in connectors, shall comply with UL 2459 and shall be made with stranded building wire. Devices shall comply with the requirements in this Section.

2.3 STRAIGHT-BLADE RECEPTACLES

- A. Hospital-Grade, Tamper Resistant, Duplex Convenience Receptacles, 125 V, 20 A: Comply with NEMA WD 1, NEMA WD 6 Configuration 5-20R, UL 498 Supplement sd, and FS W-C-596.
 - 1. Description: Single-piece, rivetless, nickel-plated, all-brass grounding system. Nickel-plated, brass mounting strap. Mechanical shutter system to help prevent insertion of foreign objects. Labeled shall comply with NFPA 70, "Health Care Facilities" Article, "Pediatric Locations" Section.
- B. Isolated-Ground, Duplex Convenience Receptacles, 125 V, 20 A: Comply with NEMA WD 1, NEMA WD 6 Configuration 5-20R, UL 498, and FS W-C-596.
 - 1. Description: Straight blade; equipment grounding contacts shall be connected only to the green grounding screw terminal of the device and with inherent

electrical isolation from mounting strap. Isolation shall be integral to receptacle construction and not dependent on removable parts.

- C. Tamper-Resistant Convenience Receptacles, 125 V, 20 A: Comply with NEMA WD 1, NEMA WD 6 Configuration 5-20R, UL 498 Supplement sd, and FS W-C-596.
 - 1. Description: Labeled shall comply with NFPA 70, "Health Care Facilities" Article, "Pediatric Locations" Section.

2.4 GFCI RECEPTACLES

- A. General Description:
 - 1. Straight blade, non-feed-through type.
 - 2. Comply with NEMA WD 1, NEMA WD 6, UL 498, UL 943 Class A, and FS W-C-596.
 - 3. Include indicator light that shows when the GFCI has malfunctioned and no longer provides proper GFCI protection.
- B. Tamper-Resistant GFCI Convenience Receptacles, 125 V, 20 A:
- C. Hospital-Grade, Tamper Resistant, Duplex GFCI Convenience Receptacles, 125 V, 20 A: Comply with NEMA WD 1, NEMA WD 6 Configuration 5-20R, UL 498 Supplement sd, and FS W-C-596.

2.5 TWIST-LOCKING RECEPTACLES

- A. Provide NEMA configurations as indicated on drawings.

2.6 PENDANT CORD-CONNECTOR DEVICES

- A. Description:
 - 1. Matching, locking-type plug and receptacle body connector.
 - 2. NEMA WD 6 Configurations L5-20P and L5-20R, heavy-duty grade, and FS W-C-596.
 - 3. Body: Nylon, with screw-open, cable-gripping jaws and provision for attaching external cable grip.
 - 4. External Cable Grip: Woven wire-mesh type made of high-strength, galvanized-steel wire strand, matched to cable diameter, and with attachment provision designed for corresponding connector.

2.7 CORD REELS

- A. **Manufacturers:** Subject to compliance with requirements, provide products by one of the following:
 - 1. Kitchen Leash by APC Group
- B. Description:
 - 1. Molded Polypropylene Housing.
 - 2. Retracting cord with adjustable stop.
 - 3. SJOW Power cord, 10 foot; rated 200 degrees.
 - 4. Receptacles Dual Duplex NEMA 5-20R unless noted otherwise.

5. Impact: UL746C
6. Hose Down: CSA 6.8.2
7. Strain Relief: CSA 6.4
8. Flame Retardant: UL 94-94V-2
9. Mounting Bracket for ceiling mount.

2.8 CORD AND PLUG SETS

- A. Description:
1. Match voltage and current ratings and number of conductors to requirements of equipment being connected.
 2. Cord: Rubber-insulated, stranded-copper conductors, with Type SOW-A jacket; with green-insulated grounding conductor and ampacity of at least 130 percent of the equipment rating.
 3. Plug: Nylon body and integral cable-clamping jaws. Match cord and receptacle type for connection.

2.9 TOGGLE SWITCHES

- A. Comply with NEMA WD 1, UL 20, and FS W-S-896.
- B. Switches, 120/277 V, 20 A:
1. Single Pole and Three Way:
 - a. **Manufacturers:** Subject to compliance with requirements, provide products by one of the following:
 - 1) [Eaton \(Arrow Hart\)](#).
 - 2) [Hubbell Incorporated; Wiring Device-Kellems](#).
 - 3) [Leviton Manufacturing Co., Inc.](#)
 - 4) [Pass & Seymour/Legrand \(Pass & Seymour\)](#).
- C. Key-Operated Switches, 120/277 V, 20 A:
1. Description: Single pole, with factory-supplied key in lieu of switch handle.
- D. Momentary Contact Switches: 2-Button, Single Pole, Low-voltage switch, mounts in standard single gang ring.
- E. Key-Operated, Single-Pole, Double-Throw, Momentary-Contact, Center-off Switches: 120/277 V, 20 A; for use with mechanically held lighting contactors, with factory-supplied key in lieu of switch handle.

2.10 WALL-BOX DIMMERS

- A. Dimmer Switches: Modular, full-wave, solid-state units with integral, quiet on-off switches, with audible frequency and EMI/RFI suppression filters.
- B. Control: Continuously adjustable slider; with single-pole or three-way switching. Comply with UL 1472.
- C. Incandescent Lamp Dimmers: 120 V; control shall follow square-law dimming curve. On-off switch positions shall bypass dimmer module for off.

1. These shall be used to control power modules driving large quantity of LED drivers using 0-10VDC control signals. This interface shall operate either 120 or 277 volt circuits, 200 ma rating.
- D. LED Dimmer Switches: Modular; compatible with LED drivers; trim potentiometer to adjust low-end dimming used where “LR” is shown, otherwise full range of 1% to 100% light or as noted. This dimmer shall operate either 120 or 277 volt circuits, 28 ma minimum rating.

2.11 WALL PLATES

- A. Single and combination types shall match corresponding wiring devices.
1. Plate-Securing Screws: Metal with head color to match plate finish.
 2. Material for Finished Spaces, except Operating Rooms and Food Service Kitchen: Smooth, high-impact thermoplastic.
 3. Material for Operating Rooms and Food Service Kitchen: **0.035-inch- (1-mm-)** thick, satin-finished, Type 302 stainless steel.
 4. Material for Unfinished Spaces: Galvanized steel.
 5. Material for Damp Locations: Cast aluminum with spring-loaded lift cover, and listed and labeled for use in wet and damp locations.
- B. Wet-Location, Weatherproof Cover Plates: NEMA 250, complying with Type 3R, weather-resistant, die-cast aluminum with lockable, weatherproof-in-use cover.

2.12 FLOOR SERVICE FITTINGS

- A. **Manufacturers:** Subject to compliance with requirements, provide products by the following:
1. **Wiremold / Legrand.**
- B. Type: Modular, flush-type, dual- or multi- service units suitable for wiring method used.
- C. Compartments: Barrier separates power from voice and data communication cabling.
- D. Service Plate: Round, die-cast aluminum with satin finish.
- E. Power Receptacle: NEMA WD 6 Configuration 5-20R, gray finish, unless otherwise indicated.
- F. Voice and Data Communication Outlet: Two modular, keyed, color-coded, RJ-45 jacks for UTP cable complying with requirements in owner’s Section 27 00 00 requirements.
- G. Description by Device Type:

FB1	Flush, Dual Service, Furniture Feed. One .75” conduit for power and One 2” conduit for data cabling. See plans for circuits and data drops. Finish selected by architect.	Legrand EFBFF Hubbell CFB2G30/2GCFFCVR
FB4	Flush, Dual Service, one piece finish flange. Four gang capacity. One .75” conduit for power and one 2”	Legrand EFG45S Hubbell

	conduit for data cabling. See plans for circuits and data drops. Finish selected by architect.	CFB2G30/24GCCVR
FB6	Flush, Dual Service, one piece finish flange. Six gang capacity. One .75" conduit for power and one 2" conduit for data cabling. See plans for circuits and data drops. Finish selected by architect.	Legrand EFB6S Evolution Hubbell CFB6G30/610GCCVR
FB8	Flush, Dual Service, one piece finish flange. Eight gang capacity. One .75" conduit for power and one 2" conduit for data cabling. See plans for circuits and data drops. Finish selected by architect.	Legrand EFB8S Evolution
FB10	Flush, Dual Service, one piece finish flange. Ten gang capacity. One .75" conduit for power and one 2" conduit for data cabling. See plans for circuits and data drops. Finish selected by architect.	Legrand EFB10S Evolution Hubbell CFB10G30/610GCCVR
FB11	Flush single service floor box suitable for the wiring method used. NEMA 5-20R duplex receptacle with brushed aluminum flange and cover plate. Hinged receptacle covers. Housing material shall be stamped steel above grade and cast iron at grade. Provide appropriate carpet and tile flanges.	Legrand 880MS(CS)/817/828 Hubbell B2431/S3825

2.13 POKE-THROUGH ASSEMBLIES

A. **Manufacturers:** Subject to compliance with requirements, provide products by the following:

1. **Wiremold / Legrand.**

B. Description:

1. Factory-fabricated and -wired assembly of below-floor junction box with multichanneled, through-floor raceway/firestop unit and detachable matching floor service-outlet assembly.
2. Comply with UL 514 scrub water exclusion requirements.
3. Size: Selected to fit cored holes in floor and matched to floor thickness.
4. Fire Rating: Unit is listed and labeled for fire rating of floor-ceiling assembly.
5. Closure Plug: Arranged to close unused cored openings and reestablish fire rating of floor.

C. Description by Device Type:

PT1	Flush, Dual Service, 4" Diameter Furniture Feed Poke-Thru. One piece finish flange. One .75" conduit for power, One 1.5" conduit for data cabling. See plans for circuits and data drops. Finish selected by architect.	Legrand 4FFATC Hubbell PT73FFS/FRF3
PT2	Flush, Dual Service Capable, 4"Diameter Poke-Thru. One .75" conduit for power, one 1.5" conduit for data cabling. Two Gang Capacity. See plans for	Legrand 4AT Evolution Hubbell S1R4PT

	circuits and data drops. Receptacles shall be NEMA 5-20R, Finish selected by architect.	
PT3	Flush, Dual Service Capable, 6"Diameter Poke-Thru. One .75" conduit for power, one 1.5" conduit for data cabling. Three Gang Capacity. See plans for circuits and data drops. Receptacles shall be NEMA 5-20R, Finish selected by architect.	Legrand 6AT Evolution Hubbell S1R6PT
PT8	Flush, Dual Service Capable, 8"Diameter Poke-Thru. One .75" conduit for power, one 2" conduit for data cabling. Five Gang Capacity. See plans for circuits and data drops. Receptacles shall be NEMA 5-20R, Finish selected by architect.	Legrand 8AT Evolution Hubbell S1R8PT
PT10	Flush, Dual Service Capable, 10"Diameter Poke-Thru. One .75" conduit for power, one 2" conduit for data cabling. Eight Gang Capacity. See plans for circuits and data drops. Receptacles shall be NEMA 5-20R, Finish selected by architect.	Legrand 10AT Evolution Hubbell S1R10PT
PT11	Flush single service floor box suitable for the wiring method used. NEMA 5-20R duplex receptacle with brushed aluminum flange and cover plate. Hinged receptacle covers.	Legrand RC7CTC Hubbell PT7FS/FRF

2.14 FINISHES

- A. Device Color:
1. Wiring Devices Connected to Normal Power System: Gray in Food Service Kitchen. As selected by Architect in other finished spaces unless otherwise indicated or required by NFPA 70 or device listing.
 2. Wiring Devices Connected to Essential Power System: Red.
 3. Isolated-Ground Receptacles: Orange.
- B. Wall Plate Color: For plastic covers, match device color.

PART 3 - EXECUTION

3.1 INSTALLATION

- A. Comply with NECA 1, including mounting heights listed in that standard, unless otherwise indicated.
- B. Coordination with Other Trades:
1. Protect installed devices and their boxes. Do not place wall finish materials over device boxes and do not cut holes for boxes with routers that are guided by riding against outside of boxes.
 2. Keep outlet boxes free of plaster, drywall joint compound, mortar, cement, concrete, dust, paint, and other material that may contaminate the raceway system, conductors, and cables.
 3. Install device boxes in brick or block walls so that the cover plate does not cross a joint unless the joint is troweled flush with the face of the wall.

4. Install wiring devices after all wall preparation, including painting, is complete.
- C. Conductors:
1. Do not strip insulation from conductors until right before they are spliced or terminated on devices.
 2. Strip insulation evenly around the conductor using tools designed for the purpose. Avoid scoring or nicking of solid wire or cutting strands from stranded wire.
 3. The length of free conductors at outlets for devices shall meet provisions of NFPA 70, Article 300, without pigtails.
 4. Existing Conductors:
 - a. Cut back and pigtail, or replace all damaged conductors.
 - b. Straighten conductors that remain and remove corrosion and foreign matter.
 - c. Pigtailing existing conductors is permitted, provided the outlet box is large enough.
- D. Device Installation:
1. Replace devices that have been in temporary use during construction and that were installed before building finishing operations were complete.
 2. Keep each wiring device in its package or otherwise protected until it is time to connect conductors.
 3. Do not remove surface protection, such as plastic film and smudge covers, until the last possible moment.
 4. Connect devices to branch circuits using pigtails that are not less than **6 inches (152 mm)** in length.
 5. When there is a choice, use side wiring with binding-head screw terminals. Wrap solid conductor tightly clockwise, two-thirds to three-fourths of the way around terminal screw.
 6. Use a torque screwdriver when a torque is recommended or required by manufacturer.
 7. When conductors larger than No. 12 AWG are installed on 15- or 20-A circuits, splice No. 12 AWG pigtails for device connections.
 8. Tighten unused terminal screws on the device.
 9. When mounting into metal boxes, remove the fiber or plastic washers used to hold device-mounting screws in yokes, allowing metal-to-metal contact.
 10. All 120 volt receptacles to be hospital grand tamper resistant.
- E. Receptacle Orientation:
1. Install ground pin of vertically mounted receptacles up, and on horizontally mounted receptacles to the right.
 2. Install hospital-grade receptacles in patient-care areas with the ground pin or neutral blade at the top.
- F. Device Plates: Do not use oversized or extra-deep plates. Repair wall finishes and remount outlet boxes when standard device plates do not fit flush or do not cover rough wall opening.
- G. Dimmers:
1. Install dimmers within terms of their listing.
 2. Install unshared neutral conductors on line and load side of dimmers according to manufacturers' device listing conditions in the written instructions.
 3. Install 0-10VDC control wiring in conduit with power wiring. Use conductors with insulation equivalent to insulation of power wiring.

- H. Arrangement of Devices: Unless otherwise indicated, mount flush, with long dimension vertical and with grounding terminal of receptacles on top. Group adjacent switches under single, multigang wall plates.
- I. Adjust locations of floor boxes and pokethroughs to suit arrangement of partitions and furnishings.

3.2 GFCI RECEPTACLES

- A. Install non-feed-through-type GFCI receptacles where protection of downstream receptacles is not required.

3.3 IDENTIFICATION

- A. Comply with Section 260553 "Identification for Electrical Systems."
- B. Identify each receptacle with panelboard identification and circuit number. Use hot, stamped, or engraved machine printing with black-filled lettering on face of plate, and durable wire markers or tags inside outlet boxes.

3.4 FIELD QUALITY CONTROL

- A. Perform the following tests and inspections with the assistance of a factory-authorized service representative:
 - 1. In healthcare facilities, prepare reports that comply with recommendations in NFPA 99.
 - 2. Test Instruments: Use instruments that comply with UL 1436.
 - 3. Test Instrument for Convenience Receptacles: Digital wiring analyzer with digital readout or illuminated digital-display indicators of measurement.
- B. Tests for Convenience Receptacles:
 - 1. Line Voltage: Acceptable range is 105 to 132 V.
 - 2. Percent Voltage Drop under 15-A Load: A value of 6 percent or higher is unacceptable.
 - 3. Ground Impedance: Values of up to 2 ohms are acceptable.
 - 4. GFCI Trip: Test for tripping values specified in UL 1436 and UL 943.
 - 5. Using the test plug, verify that the device and its outlet box are securely mounted.
 - 6. Tests shall be diagnostic, indicating damaged conductors, high resistance at the circuit breaker, poor connections, inadequate fault current path, defective devices, or similar problems. Correct circuit conditions, remove malfunctioning units and replace with new ones, and retest as specified above.
- C. Test straight-blade convenience outlets in patient-care areas for the retention force of the grounding blade according to NFPA 99. Retention force shall be not less than 4 oz. (115 g).
- D. Wiring device will be considered defective if it does not pass tests and inspections.
- E. Prepare test and inspection reports.

END OF SECTION

SECTION 26 5119

LED INTERIOR LIGHTING

PART 1 - GENERAL

1.1 RELATED DOCUMENTS

- A. Drawings and general provisions of the Contract, including General and Supplementary Conditions and Division 01 Specification Sections, apply to this Section.

1.2 SUMMARY

- A. Section Includes:
 - 1. Interior solid-state luminaires that use LED technology.
 - 2. Lighting fixture supports.
 - 3. Standby Emergency Power supplies for individual luminaires
- B. Related Requirements:
 - 1. Section 26 09 23 "Lighting Control Devices" for automatic control of lighting, including time switches, photoelectric relays, occupancy sensors, and multipole lighting relays and contactors.
 - 2. Section 26 09 36 "Standalone Multipreset Modular Dimming Controls" for architectural dimming systems and for fluorescent dimming controls with dimming ballasts specified in interior lighting Sections.
 - 3. Section 26 09 43 "Relay-Based Lighting Controls" for manual or programmable control systems with low-voltage control wiring or data communication circuits.

1.3 DEFINITIONS

- A. CCT: Correlated color temperature.
- B. CRI: Color Rendering Index.
- C. Fixture: See "Luminaire."
- D. IP: International Protection or Ingress Protection Rating.
- E. LED: Light-emitting diode.
- F. Lumen: Measured output of lamp and luminaire, or both.
- G. Luminaire: Complete lighting unit, including lamp, reflector, and housing.

1.4 ACTION SUBMITTALS

- A. Product Data: For each type of product.
 - 1. Arrange in order of luminaire designation.
 - 2. Include data on features, accessories, and finishes.

3. Include physical description and dimensions of luminaires.
 4. Include emergency lighting units, including batteries and chargers.
 5. Include life, output (lumens, CCT, and CRI), and energy efficiency data.
 6. Photometric data and adjustment factors based on laboratory tests, complying with IESNA Lighting Measurements Testing and Calculation Guides, of each lighting fixture type. The adjustment factors shall be for lamps and accessories identical to those indicated for the lighting fixture as applied in this Project. Report data compliant with IES LM-79 and IES LM-80. Only Absolute Photometry is acceptable.
 - a. Manufacturers' Certified Data: Photometric data certified by manufacturer's laboratory with a current accreditation under the National Voluntary Laboratory Accreditation Program for Energy Efficient Lighting Products (NVLAP).
- B. Shop Drawings: For nonstandard or custom luminaires.
1. Include plans, elevations, sections, and mounting and attachment details.
 2. Include details of luminaire assemblies. Indicate dimensions, weights, loads, required clearances, method of field assembly, components, and location and size of each field connection.
 3. Include diagrams for power, signal, and control wiring.
- C. LEED Submittals:
1. Product Data for Credit IEQ 4.2: For paints and coatings, documentation including printed statement of VOC content.
 2. Laboratory Test Reports for Credit IEQ 4.2: For paints and coatings, documentation indicating that products comply with the testing and product requirements of the California Department of Public Health's "Standard Method for the Testing and Evaluation of Volatile Organic Chemical Emissions from Indoor Sources Using Environmental Chambers."
- D. Samples: For each luminaire and for each color and texture with standard factory-applied finish.
- E. Samples for Initial Selection: For each type of luminaire with custom factory-applied finishes.
1. Include Samples of luminaires and accessories involving color and finish selection.
- F. Samples for Verification: For each type of luminaire.
1. Include Samples of luminaires and accessories to verify finish selection.
- G. Product Schedule: For luminaires and lamps. Use same designations indicated on Drawings.

1.5 INFORMATIONAL SUBMITTALS

- A. Coordination Drawings: Reflected ceiling plan(s) and other details, drawn to scale, on which the following items are shown and coordinated with each other, using input from installers of the items involved:
1. Lighting luminaires.
 2. Suspended ceiling components.
 3. Partitions and millwork that penetrate the ceiling or extend to within 12 inches (300 mm) of the plane of the luminaires.
 4. Structural members to which equipment and or luminaires will be attached.
 5. Initial access modules for acoustical tile, including size and locations.
 6. Items penetrating finished ceiling, including the following:
 - a. Other luminaires.
 - b. Air outlets and inlets.
 - c. Speakers.
 - d. Sprinklers.

- e. Access panels.
- f. Ceiling-mounted projectors.
- g.
- 7. Moldings.
- B. Qualification Data: For testing laboratory providing photometric data for luminaires.
- C. Seismic Qualification Certificates: For luminaires, accessories, and components, from manufacturer.
 - 1. Basis for Certification: Indicate whether withstand certification is based on actual test of assembled components or on calculation.
 - 2. Dimensioned Outline Drawings of Equipment Unit: Identify center of gravity and locate and describe mounting and anchorage provisions.
- D. Detailed description of equipment anchorage devices on which the certification is based and their installation requirements.
- E. Product Certificates: For each type of luminaire.
- F. Product Test Reports: For each luminaire, for tests performed by manufacturer or a qualified testing agency holding NVLAP accreditation.
- G. Sample warranty.

1.6 CLOSEOUT SUBMITTALS

- A. Operation and Maintenance Data: For luminaires and lighting systems to include in operation and maintenance manuals.
 - 1. Provide a list of all lamp types LED Modules and LED Drivers used on Project; use ANSI and manufacturers' codes.

1.7 MAINTENANCE MATERIAL SUBMITTALS

- A. Furnish extra materials that match products installed and that are packaged with protective covering for storage and identified with labels describing contents citing lighting fixture types.
 - 1. Lamps: 2 for every 100 of each type and rating installed. Furnish at least one of each type.
 - 2. Diffusers and Lenses: One for every 100 of each type and rating installed. Furnish at least one of each type.
 - 3. Globes and Guards: One for every 20 of each type and rating installed. Furnish at least one of each type.

1.8 QUALITY ASSURANCE

- A. Luminaire Photometric Data Testing Laboratory Qualifications: Luminaire manufacturer's laboratory that is accredited under the NVLAP for Energy Efficient Lighting Products.
- B. Luminaire Photometric Data Testing Laboratory Qualifications: Provided by an independent agency, with the experience and capability to conduct the testing indicated, that is an NRTL as defined by OSHA in 29 CFR 1910.7, accredited under the NVLAP for Energy Efficient Lighting Products, and complying with the applicable IES testing standards.

- C. Provide luminaires from a single manufacturer for each luminaire type.
- D. Each luminaire type shall be binned within a three-step MacAdam Ellipse to ensure color consistency among luminaires.
- E. Mockups: For interior lighting luminaires in room or module mockups, complete with power and control connections.
 - 1. Obtain Architect's approval of luminaires in mockups before starting installations.
 - 2. Maintain mockups during construction in an undisturbed condition as a standard for judging the completed Work.
 - 3. Approval of mockups does not constitute approval of deviations from the Contract Documents contained in mockups unless Architect specifically approves such deviations in writing.
 - 4. Subject to compliance with requirements, approved mockups may become part of the completed Work if undisturbed at time of Substantial Completion.

1.9 DELIVERY, STORAGE, AND HANDLING

- A. Protect finishes of exposed surfaces by applying a strippable, temporary protective covering before shipping.

1.10 WARRANTY

- A. Warranty: Manufacturer and Installer agree to repair or replace components of luminaires that fail in materials or workmanship within specified warranty period.
- B. Warranty Period: Five year(s) from date of Substantial Completion.

PART 2 - PRODUCTS

2.1 PERFORMANCE REQUIREMENTS

- A. Seismic Performance: Luminaires shall withstand the effects of earthquake motions determined according to ASCE/SEI 7.
- B. Seismic Performance: Luminaires and lamps shall be labeled vibration and shock resistant.
 - 1. The term "withstand" means "the luminaire will remain in place without separation of any parts when subjected to the seismic forces specified and the luminaire will be fully operational during and after the seismic event."

2.2 LUMINAIRE REQUIREMENTS

- A. Electrical Components, Devices, and Accessories: Listed and labeled as defined in NFPA 70, by a qualified testing agency, and marked for intended location and application.
- B. NRTL Compliance: Luminaires for hazardous locations shall be listed and labeled for indicated class and division of hazard by an NRTL.
- C. FM Global Compliance: Luminaires for hazardous locations shall be listed and labeled for indicated class and division of hazard by FM Global.

- D. Recessed Fixtures: Comply with NEMA LE 4.
- E. Bulb shape complying with ANSI C79.1.
- F. Lamp base complying with ANSI C81.61 or IEC 60061-1, where employing universal base or mount.
- G. CRI of minimum 80. CCT of 3500 K.
- H. L70 rated lamp life of 50,000 hours.
- I. Lamps dimmable as indicated or 0.5 to 100 percent of maximum light output, via 0-10 VDC control signal or, where indicated, Digital Dimming Control Signal.
- J. Field Replaceable driver.
- K. Nominal Operating Voltage: Universal voltage 120 V ac or 277 V ac unless scheduled differently.
 - 1. Lens Thickness: At least 0.125 inch (3.175 mm) minimum unless otherwise indicated.
- L. Housings:
 - 1. Hydroformed, cast or extruded-aluminum housing and heat sink suitable for the environment.
 - 2. Anodized or powder-coat finish.

2.3 LED LAMPS AND DRIVERS:

- A. Minimum CRI Ra- 82 or as specified.
- B. Lumen output shall be Luminaire Lumens or Delivered Lumens. Source lumens shall not be used.
- C. Each luminaire type shall be binned within a three-step MacAdam Ellipse to ensure color consistency among luminaires.
- D. LED Rated life L70 of 50,000 hours per (IES LM-80). Luminaire shall maintain LED operating temperature to achieve this rating per TM-21.
- E. Flicker: No visible or detectable flicker, operating on all dimmed intensities.
- F. Dimming drivers shall be compatible with the control method shown on the drawings. All dimmed drivers shall use 0-10vdc control unless specified differently. Minimum level as scheduled.
- G. Inrush current shall be reported and the lighting controls adjusted for inrush of LED product supplied.
- H. THD: THD shall not exceed 80%.
- I. Minimum driver efficiency shall be 83%.
- J. LED module shall be replaceable in the field using modules with digitally traceable matching modules.

- K. Luminaire shall be NRTL Listed at intended operating temperature.
- L. Photometry shall be measured or absolute photometry. Derived or calculated photometry shall not be provided for consideration.
- M. Approved Manufacturers- Drivers
 - 1. General Electric.
 - 2. Philips.
 - 3. Osram / Sylvania.
 - 4. Lutron
 - 5. EldoLED
 - 6. Thomas Research
- N. Approved Manufacturers- LEDs
 - 1. General Electric
 - 2. Philips
 - 3. Osram
 - 4. Cree
 - 5. Xicato
 - 6. Nichia
- O. Approved Manufacturers for Luminaires shall be as scheduled.

2.4 MATERIALS

- A. Metal Parts:
 - 1. Free of burrs and sharp corners and edges.
 - 2. Sheet metal components shall be steel unless otherwise indicated.
 - 3. Form and support to prevent warping and sagging.
- B. Doors, Frames, and Other Internal Access: Smooth operating, free of light leakage under operating conditions, and designed to permit relamping without use of tools. Designed to prevent doors, frames, lenses, diffusers, and other components from falling accidentally during relamping and when secured in operating position.
- C. Diffusers and Globes:
 - 1. Acrylic Diffusers: One hundred percent virgin acrylic plastic, with high resistance to yellowing and other changes due to aging, exposure to heat, and UV radiation.
 - 2. Glass: Annealed crystal glass unless otherwise indicated.
 - 3. Lens Thickness: At least 0.125 inch (3.175 mm) minimum unless otherwise indicated.
- D. Housings:
 - 1. Hydroformed, cast or extruded-aluminum housing and heat sink suitable for the environment.
 - 2. Anodized or powder-coat finish.
- E. Factory-Applied Labels: Comply with UL 1598. Include recommended lamps and line wattage. Locate labels where they will be readily visible to service personnel, but not seen from normal viewing angles when lamps are in place.
 - 1. Label shall include the following lamp characteristics:
 - a. "USE ONLY" and include specific lamp type.
 - b. Lamp diameter, shape, size, wattage, and coating.
 - c. CCT and CRI for all luminaires.

2.5 METAL FINISHES

- A. Variations in finishes are unacceptable in the same piece. Variations in finishes of adjoining components are acceptable if they are within the range of approved Samples and if they can be and are assembled or installed to minimize contrast.

2.6 LUMINAIRE FIXTURE SUPPORT COMPONENTS

- A. Comply with requirements in Section 26 05 29 "Hangers and Supports for Electrical Systems" for channel and angle iron supports and nonmetallic channel and angle supports.
- B. Single-Stem Hangers: 1/2-inch (13-mm) steel tubing with swivel ball fittings and ceiling canopy. Finish same as luminaire.
- C. Wires: ASTM A 641/A 641 M, Class 3, soft temper, zinc-coated steel, 12 gauge (2.68 mm).
- D. Rod Hangers: 3/16-inch (5-mm) minimum diameter, cadmium-plated, threaded steel rod.
- E. Hook Hangers: Integrated assembly matched to luminaire, line voltage, and equipment with threaded attachment, cord, and locking-type plug.

2.7 GENERAL REQUIREMENTS FOR EMERGENCY LIGHTING

- A. Electrical Components, Devices, and Accessories: Listed and labeled as defined in NFPA 70, by a qualified testing agency, and marked for intended location and application.
- B. NRTL Compliance: Fabricate and label emergency lighting units, exit signs, and batteries to comply with UL 924.
- C. Comply with NFPA 70 and NFPA 101.
- D. Comply with NEMA LE 4 for recessed luminaires.
- E. Internal Type Emergency Power Unit: Self-contained, modular, battery-inverter unit, factory mounted within luminaire body and compatible with LED light source and driver, including dimming driver.
 - 1. Emergency Connection: Operate luminaire continuously at an output of 5 watts upon loss of normal power. Connect unswitched circuit to battery-inverter unit and switched circuit to luminaire ballast.
 - 2. Operation: Relay automatically turns driver/led module on when power-supply circuit voltage drops to 80 percent of nominal voltage or below. Lamp automatically disconnects from battery when voltage approaches deep-discharge level. When normal voltage is restored, relay disconnects lamps from battery, and battery is automatically recharged and floated on charger.
 - 3. Environmental Limitations: Rate equipment for continuous operation under the following conditions unless otherwise indicated:
 - a. Ambient Temperature: Less than 0 deg F or exceeding 104 deg F with an average value exceeding 95 deg over a 24-hour period.
 - b. Ambient Storage Temperature: Not less than minus 4 deg F and not exceeding 140 deg F
 - c. Humidity: More than 95 percent (condensing).

- d. Altitude: Exceeding 3300 feet
- 4. Battery: Sealed, maintenance-free, lead-acid type.
- 5. Charger: Fully automatic, solid-state, constant-current type with sealed power transfer relay.
- 6. Integral Self-Test: Factory-installed electronic device automatically initiates code-required test of unit emergency operation at required intervals. Test failure is annunciated by an integral audible alarm and a flashing red LED.

PART 3 - EXECUTION

3.1 EXAMINATION

- A. Examine substrates, areas, and conditions, with Installer present, for compliance with requirements for installation tolerances and other conditions affecting performance of the Work.
- B. Examine roughing-in for luminaire to verify actual locations of luminaire and electrical connections before fixture installation. Proceed with installation only after unsatisfactory conditions have been corrected.

3.2 TEMPORARY LIGHTING

- A. If approved by the Architect, use selected permanent luminaires for temporary lighting. When construction is sufficiently complete, clean luminaires used for temporary lighting and install new lamps.

3.3 INSTALLATION

- A. Comply with NECA 1.
- B. Install luminaires level, plumb, and square with ceilings and walls unless otherwise indicated.
- C. Supports:
 - 1. Sized and rated for luminaire weight.
 - 2. Able to maintain luminaire position after cleaning and repair.
 - 3. Provide support for luminaire without causing deflection of ceiling or wall.
 - 4. Luminaire mounting devices shall be capable of supporting a horizontal force of 100 percent of luminaire weight and vertical force of 400 percent of luminaire weight.
- D. Flush-Mounted Luminaire Support:
 - 1. Secured to outlet box.
 - 2. Attached to ceiling structural members at four points equally spaced around circumference of luminaire.
 - 3. Trim ring flush with finished surface.
- E. Wall-Mounted Luminaire Support:
 - 1. Attached to structural members or approved backer plate in walls
 - 2. Do not attach luminaires directly to gypsum board.
- F. Ceiling-Mounted Luminaire Support:
 - 1. Ceiling mount with four 5/32-inch- (4-mm) diameter steel wire or aircraft cable supports.

2. Ceiling mount with hook mount.
- G. Suspended Luminaire Support:
1. Pendants and Rods: Where longer than 48 inches (1200 mm), brace to limit swinging.
 2. Stem-Mounted, Single-Unit Luminaires: Suspend with twin-stem hangers. Support with approved outlet box and accessories that hold stem and provide damping of luminaire oscillations. Support outlet box vertically to building structure using approved devices.
 3. Continuous Rows of Luminaires: Use tubing or stem for wiring at one point and wire support for suspension for each unit length of luminaire chassis, including one at each end.
 4. Do not use ceiling grid as support for pendant luminaires. Connect support wires or rods to building structure.
- H. Ceiling-Grid-Mounted Luminaires:
1. Secure to any required outlet box.
 2. Secure luminaire to the luminaire opening using approved fasteners in a minimum of four locations, spaced near corners of luminaire.
 3. Use approved devices and support components to connect luminaire to ceiling grid and building structure in a minimum of four locations, spaced near corners of luminaire.
- I. Comply with requirements in Section 26 05 19 "Low-Voltage Electrical Power Conductors and Cables" for wiring connections.

3.4 IDENTIFICATION

- A. Identify system components, wiring, cabling, and terminals. Comply with requirements for identification specified in Section 26 05 53 "Identification for Electrical Systems."

3.5 FIELD QUALITY CONTROL

- A. Perform the following tests and inspections:
1. Operational Test: After installing luminaires, switches, and accessories, and after electrical circuitry has been energized, test units to confirm proper operation.
 2. Test for Emergency Lighting: Interrupt power supply to demonstrate proper operation. Verify transfer from normal power to battery power and retransfer to normal.
- B. Luminaire will be considered defective if it does not pass operation tests and inspections.
- C. Prepare test and inspection reports.

3.6 STARTUP SERVICE

- A. Comply with requirements for startup specified in Section 26 09 43 "Relay-Based Lighting Controls."

3.7 ADJUSTING

- A. Occupancy Adjustments: When requested within 12 months of date of Substantial Completion, provide on-site assistance in adjusting the direction of aim of luminaires to suit occupied conditions. Make up to two visits to Project during other-than-normal hours for this purpose. Some of this work may be required during hours of darkness.

1. During adjustment visits, inspect all luminaires. Replace luminaires that are defective.
2. Parts and supplies shall be manufacturer's authorized replacement parts and supplies.
3. Adjust the aim of luminaires in the presence of the Architect.

END OF SECTION

DIVISION 27 – COMMUNICATIONS

Section 27 0000	General Common Conditions for All Communication Sections
Section 27 0100	Operation and Maintenance of Communications Systems
Section 27 0113	Warranty, Product and System
Section 27 0119	Field Testing and Reporting
Section 27 0133	Shop Drawings, Product Data, Samples Design Records and Existing Conditions
Section 27 0143	Qualifications and Required Training for Contractors and Installers
Section 27 0171	Responsibility and Workmanship of Contractor
Section 27 0500	Common Work Results for Communications
Section 27 0526	Grounding and Bonding for Communications Systems
Section 27 0528	Pathways for Communications Systems
Section 27 0529	Hangers and Supports for Communication Systems
Section 27 0533	Conduits and Back Boxes for Communications Systems
Section 27 0536	Cable Trays for Communications Systems
Section 27 0543	Underground Ducts, Utility Poles, and Raceways for Inter-Building/Campus Cable Routing
Section 27 0553	Identification for Low-Voltage Cables and Labeling
Section 27 1100	Equipment Room Fittings
Section 27 1116	Cabinets, Racks, Frames, and Enclosures
Section 27 1119	Termination Blocks and Patch Panels
Section 27 1300	Backbone Cabling
Section 27 1500	Horizontal Cabling
Section 27 1513	Copper Cable
Section 27 1543	Faceplates and Connectors
Section 27 1619	Patch Cables
Section 27 5223	Nurse Call/Code Blue Systems
Section 27 5319	Internal Cellular, Paging and Antenna Systems
Section 27 6001	Appendix 01 – Deviation Request Process
Section 27 6002	Appendix 02 – Document Refresh Process
Section 27 6003	Appendix 03 – Data Center, Tec, TDR Part Numbers
Section 27 6004	Appendix 04 – Reference Standards
Section 27 6005	Appendix 05 – Definitions and Abbreviations
Section 27 6006	Appendix 06 – Material Suppliers
Section 27 6007	Appendix 07 – Siemon Certified Installation Firms
Section 27 6008	Appendix 08 – Lead Wall Penetrations

THIS PAGE LEFT BLANK INTENTIONALLY

SECTION 27000

GENERAL COMMON CONDITIONS FOR ALL COMMUNICATION SECTIONS

PART 1 - GENERAL

1.1 RELATED DOCUMENTS

- A. Drawings and General Provisions of the Contract, including General and Supplementary Conditions and Division 01 Specification Sections, and other documents as designated, apply to this Document.
- B. See Division 7 and section 27 01 00 Part 3 for additional requirements.

1.2 RELATED SECTIONS

- A. Specifications throughout all Divisions of the Project Manual are directly applicable to this section, and this section is directly applicable to them.
 - 1. All Division 27 Sections
 - 2. Requirements of the following Division 26 sections apply to this section
 - a. Basic electrical requirements
 - b. Basic electrical materials and methods
 - c. Grounding, earthing, and bonding
 - 3. Division 21 Fire Suppression
 - 4. Division 22 Plumbing
 - 5. Division 23 HVAC
 - 6. Division 28 Electronic Safety and Security

1.3 SUMMARY

- A. The work on many processes in this section are not part of the Division 27 contract. The respective trades shall include their portions, and administration topics that are applicable to all Division 27 Sections in their proposals.
- B. This document is based upon the 2018 Construction Specification Institute (CSI) Master Format numbers and titles for sections within Division 27: Communications.
- C. Where IT or Owner representation is stipulated in this Division, it shall be provided by the Data Center Operations Infrastructure Cabling team.

1.4 SUBMITTALS

- A. Product data shall be supplied for any parts/equipment that does not match the specified part number.
- B. Shop drawings
 - 1. Labeling schedules and layouts in owner designated electronic format
 - 2. Cabling administrative drawings

1.5 CONDITIONS

- A. Drawings and General provisions of the contract, including Uniform General Conditions, Supplementary General Conditions, architectural plans and specifications, requirements of Division 1, electrical, mechanical, plumbing, audio visual, security and telecommunications specifications and plans apply to the communications section, and shall be consider a part of this section. The contractor shall read all sections in their entirety and apply them as appropriate for work in this section.
- B. Prior to beginning installation, a kick-off meeting to properly coordinate the tray installation and expectations should be held. It should be arranged by the General

Contractor, and at a minimum include representatives of the following trades: FP&D, Electrical (Div. 26), Structured cable, Nurse Call, paging, building automation and control, plumbing, HVAC, fire sprinkler, framing, and others as applicable. The Data Center Operations Infrastructure Cabling Team will lead the meeting.

C. Conflicts:

1. Drawings and specifications are to be used in conjunction with one another and to supplement one another. In general, the drawings determine the nature and quality of the installation, materials, and tests. The quantities are derived from the drawings, details, listings, and manufacturer's directions.
 - a. Final order counts and distances are the contractor's responsibility.
2. If there is an apparent conflict between the drawings and specifications, or between specification sections, the items with the greater quality or quantity shall be submitted, estimated, and installed.
3. Clarification with the Owner and/or Owner's Representative about these items shall be made prior to the ordering and installation.

D. Owner / Contractor

1. The Architect/Project Manager will submit appropriate scope of work information that will allow the contractor to appropriately plan and bid the project.

E. Contractor

1. Furnish all labor, materials, tools, equipment and services for the installation described herein. Provide add/deduct unit pricing for all components as part of the bid response. Base fixed price add/deduct units on an average cable length of 175 linear feet.
2. The Contractor shall procure and maintain for the duration of this agreement, insurance against claims.
3. Use of Subcontractors: Successful bidder shall inform the Owner's contact and/or General Contractor in writing about the intention to use Subcontractors and the scope of work for which they are being hired. The Owner or Owner's designated contact must approve the chosen Subcontractors in writing prior to the Subcontractor's hiring and start of any work. The low voltage Subcontractor must be approved and certified. Refer to the listing in appendix 7.
4. Use of Subcontractors: The Contractor's designated project manager will be recognized as the single point of contact. The Project manager shall oversee all work performed to ensure compliance with specifications as outlined in bid documents (which includes all specifications and drawings) to ensure a quality installation.

1.6 SCOPE OF WORK:

- A. This establishes a communications infrastructure to be used as signal pathways for voice, high-speed data transmission, and other low voltage services. Contractor shall:
1. Comply with all Master Specifications documents and the following requirements for a complete project installation.
 2. Provide a structured cabling system as described hereafter that includes, but is not limited to, supplying, installing, labeling and testing of fiber backbone, fiber and voice riser cable; data copper, fiber, and voice copper horizontal cabling, cable connectors, communications outlets and terminations, patch cables, and equipment racks/cabinets for networking hardware and patch panels.
 3. All requirements and specifications will be enforced. Cable pathways and runs to individual outlets are not shown in their entirety but shall be provided as if shown in their entirety.
 4. Coordinate with electrical tradespersons to verify conduit routing does not cause cabling to exceed allowable link length.
 5. Follow industry standard installation procedures, including BICSI Installation Standard and guidelines as well as specified manufacturers standard recommended procedures and installation practices for communications cable to

assure that the mechanical and electrical transmission characteristics of this cable plant and equipment are maintained.

6. The Division 27 work shall be performed by an approved, certified installer.
7. The low voltage communications Subcontractor shall complete non-concealed work.

1.7 REFERENCE STANDARDS:

- A. The latest published edition of a reference shall be applicable to this Project unless identified by a specific edition date.
- B. All reference amendments adopted prior to the effective date of the Contract shall be applicable to this Project.
- C. The publications listed below form a part of this specification. The publications are referred to in the text by basic designation only.
- D. Specific reference in specifications to codes, rules, regulations, standards, manufacturer's instructions, or requirements of regulatory agencies shall mean reference to the latest printed edition of each in effect at the date of contract.
- E. Codes and Standards (Most recent editions with addenda/TSB, etc.) All materials, installation and workmanship shall meet or exceed the applicable requirements and standards addressed within the references listed in **Appendix 04**.

1.8 DEFINITIONS:

- A. Definitions and Abbreviations are listed in **Appendix 05**:

PART 2 - PRODUCTS

2.1 PRODUCTS AND WORK NOT included BY DIVISION 27

- A. Others shall separately purchase and/or provide certain equipment and miscellaneous items that will be installed during the installation process. Such items may not be indicated in the documents. Contractor shall coordinate with the Owner and his suppliers when considering:
 1. Provision and installation of phone systems, computer hardware, and related networking software and equipment.
 2. Provision and installation of multi-port routers, hubs in communications rooms.
 - a. TEC/TDR UPS's are owner provided.
 3. Communications grounding bus bars and grounding wires connecting to the main building electrode system by Division 26.
 4. Dedicated power panels, ground bus bars, circuits and utility outlets.
 5. Installation and finishing of fire-rated plywood backboards.
 6. Building mechanical ductwork, cooling/heating system, and environmental control sensors.
 7. Communication pathway devices such as, conduits, conduit sleeves, back boxes, and penetrations in walls and floors. Including, but not limited to concealed work, office spaces and open areas.
 8. Provision and installation of modular furniture and millwork.

PART 3 - PENETRATIONS

3.1 THE WORK IN THIS SECTION IS IN DIVISION 7 CONTRACT; AND VERIFIED COMPLETE AT PROJECT TURNOVER.

- A. Wall Penetrations - Fire - Smoke – Sound
 1. All fire, smoke, and sound wall penetrations must be correctly made to protect the safety of patients and employees. A facility is designed/architected and built with fire integrity that must not be lost as the building is modified over its lifetime.

2. The items listed often penetrate 1 – and 2 – hour fire-resistance-rated (FRR) assemblies. General requirements for filling the space between the item in question and the wall are found in NFPC 101® Section 8.2.3.2.4.2. There is the option to either fill the space with appropriately rated fire-stop material or protect the space with an approved device designed to maintain the fire resistance of the wall.
 3. If a sleeve is used around the item that transverses the wall, the sleeve must be installed into the wall without any opening between the sleeve and the wall. The open space within the sleeve must then be filled with appropriately rated fire stop.
- B. All items listed in 1 through 2 must have penetrations in fire-resistance-rated assemblies filled to maintain the integrity of the fire barrier.
1. Conduits
 - a. When conduit passes through a wall that is either rated or must be fire-stopped due to lack of sprinklers in the compartment, it is essential to fill any gap around the conduit as described above.
 2. Cables/Wires
 - a. Sometimes cables or wires are passed through a penetration contained in a fire wall as a single installation. This often happens in a health care organization with communication cables. Even in these cases, the penetration must be patched appropriately.
 3. NOTE: Fire, smoke, and sound wall penetrations are also governed by local and state building codes.
 4. NOTE: This requirement applies to all departments, organizations, employees, and/or vendors who perform structured cable work in the facilities for:
 - a. Telephony and Computer networks, fire, smoke, and sound wall penetrations, alarm systems, security systems, HVAC Control or sensors, patient entertainment systems, announcing systems, nurse call, telemetry, RFID, etc.
 5. NOTE: While this document is written specifically for low voltage wiring, the JCAHO standards apply for any fire or smoke wall penetration. As you perform work in the facility, if you note any existing penetrations that are not up to standard, please notify the construction Project Manager immediately.
 6. While Facility Engineering has the overall responsibility, each department, organization, employee, and/or vendor has the responsibility to follow the process in obtaining a permit from facility engineering before work is started and to follow the guidelines to maintain the fire/smoke wall integrity.
- C. Process:
1. NOTE: This process applies to any person, group, and/or vendor who perform low voltage cable installations at any Intermountain facility or clinic.
 - a. Fire/Smoke Walls
 - 1) Any Vendor, department, and/or person needing to do any cable work that involves wall penetrations, adding to existing or new, are required to obtain a “Low Voltage Cable Work Permit” from Facility Engineer.
 - b. Above Ceiling Work
 - 1) Any vendor, department, and/or person needing to do any cable work above ceiling tiles, adding to existing or new, are required to obtain all required permits.
 - c. Above Ceiling Permit to be obtained from Facilities Management
 - 1) The permit requires detail information as to what work is being done, where the work will be done. The permit will also state the current approved sealing compound for the facility and specific requirements for conduits etc.
 - 2) There may also be specific rules regarding how work may be conducted in certain areas of the hospital. NOTE: Different manufacture’s sealing products can NOT be used in the same penetration. Therefore, if an additional cable is added to an

existing penetration, and you don't have the same brand of caulk, you must remove all of the caulk and re-do the seal completely.

- d. ICRA Permit to be obtain from Infectious Preventionist
 - e. Hot Work Permit to be obtain from Facilities Engineer
2. Quality of Work
- a. Facility Engineering Orientation

3.2 MEASUREMENT PROCEDURES:

- A. The Contractor shall
- 1. Coordinate supports, adjacent construction, and fixture locations to ensure actual dimensions correspond to established dimensions.
 - 2. Verify dimensions in areas of installation by field measurements before fabrication and indicate measurements and scale on shop drawings.
 - 3. Coordinate fabrication schedule with construction progress to avoid delaying the work.
 - 4. Where field measurements cannot be made without delaying the work, establish dimensions and coordinate with the General Contractor.
 - 5. When approved, proceed with fabricating units without field measurements.

3.3 CHANGES

A. ALTERNATES:

- 1. If an alternate material is proposed that is equal to or exceeds specified requirements, Contractor shall provide manufacturers' specifications in writing for Owner approval prior to purchase and installation.
- 2. Substitutions of material by the Contractor shall be in writing complete with written manufacturers' specifications. The material substituted shall not void, alter or change manufacturers' structured cabling system warranty.
- 3. Contractor shall:
 - a. Provide a complete cabling infrastructure according to these written specifications and drawings. If the Owner changes the scope of work to be performed by the Contractor, it shall be in writing.
 - b. Promptly respond to these changes with a complete material list, including pricing, and labor in writing presented to the Owner for approval. Also include unit pricing.
 - c. Do not proceed with any additional scope of work without a signed approval by the Owner.
- 4. Owner will not pay for additional work performed by the Contractor without signed approval of these changes. Contractor will submit a copy of signed change order upon billing.
- 5. The Owner's Infrastructure Cable team will be the final judge of acceptability, with review by Owner's Representative and the distribution of the acceptance by the Architect. No substitute shall be ordered, installed or utilized without the

Architect's prior written verification of acceptance from the Owner's Infrastructure Cable team.

B. SUBSTITUTION PROCEDURES

- 1. Substitution may be considered when a product becomes unavailable through no fault of the Contractor.
- 2. Document each request with complete data substantiating compliance of proposed substitution with Contract Documents. Include in each request for substitution:
 - a. Product identification, manufacturer's name and address.
 - b. Product Data: Description, performance and test data, reference standards, finishes and colors.
 - c. Samples: Finishes

- d. Complete and accurate drawings indicating construction revisions required (if any) to accommodate substitutions.
 - e. Data relating to changes required in construction schedule.
 - f. Cost comparison between specified and proposed substitution.
3. Substitutions will not be considered when they are indicated or implied on shop drawing or product data submittals, without separate written request, or when acceptance will require revision to the Contract Documents.
 4. The Owner will be the final judge of acceptability, with review by Owner's Representative and the distribution of the acceptance by the Architect.
 5. No substitute shall be ordered, installed or utilized without the Architect's prior written verification of acceptance from the Owner's Infrastructure Cable team.

PART 4 - EXECUTION

4.1 QUALITY ASSURANCE

- A. Regulatory Requirements:
 1. Contractor shall supply all city, county, and state telecommunication cabling permits required by appropriate governing agency.
 2. Prior to commencing work, the Contractor and staff shall secure all required Intermountain Healthcare permits including, but not limited to; facility sign in, ceiling work permits, hot work permits, and confined space permits.
 3. Contractor shall be city, county, and state-licensed and/or bonded as required for communications/low voltage cabling systems work.
- B. Certifications:
 1. Contractor shall submit an up-to-date and valid certification verifying qualifications of the Contractor and installers to perform the work specified herein at time of bid submission.
 2. Contractor shall have a complete working knowledge of low voltage cabling applications such as, but not limited to data, voice and video network systems.
 3. Contracting firm shall have installed similar-sized systems in at least ten (10) other projects in the last five years prior to this bid and be regularly engaged in the business of installation of the types of systems specified in this document. Certification shall include, but not be limited to, items such as name and location of project contacts and numbers, total square footage, total number of cables/drops, types of media, etc.
 4. Contractor shall provide certificates for the appropriate insurance coverage as defined in contract documents.
 5. All installer personnel that will be assigned to this project shall be listed in a qualification document. 50% of the personnel working on the job site shall have a minimum of 3 years' experience in the installation of the types of systems, equipment, and cables specified in this document. Any personnel substitutions shall be noted in writing to Owner's Data Center Operations Infrastructure
 6. Cabling representative prior to commencement of work.
 7. BICSI ITS Cabling Installation Program Installer Level 1 or 2 or Technician certifications may be substituted in lieu of the 3-year requirement. All cabling installers shall be trained and certified by the cable manufacturer for communication cabling installations and maintenance of said materials.
 7. Refer also to General Conditions.
- C. Administrative Requirements and Coordination:
 1. The Contractor shall:
 - a. Ensure that all technicians performing work have obtain badge access 48 hours prior to scheduled start.
 - b. Provide a specified contact person (name and contact number) for coordination to attend project meetings with the communication consultant, the Owner and others.
 - c. Coordinate work of this section with Owner's system specifications, workstations, equipment suppliers, and installers.

- d. Coordinate installation work with other crafts (examples include ceiling grid contractors, HVAC and sheet metal contractors, etc.) under the direction of the General Contractor to resolve procedures and installation placement for cable trays and cable bundle pathways. The goal of this coordination will be to establish priority pathways for critical data/voice network cable infrastructure, materials, associated hardware, as well as mitigate delays to the project and to allow service access for communications and HVAC components. Damage by Contractor to the craftwork of others will be remediated at the Contractor's expense in a timely manner.
 - e. Exchange information and agree on details of equipment arrangements and installation interfaces. Record agreements reached in meetings and distribute record to other participants, Owner and communication consultant.
 - f. Arrangement, layout, and locations of distribution frames, patch panels, and cross-connect blocks in equipment rooms and racks to accommodate and optimize arrangement and space requirements of any service provider equipment, telephone system, and LAN equipment as directed by Data Center Operations. Tasks shall be coordinated with the Owner's Data Center Operations team, and other trades' installation representatives.
 - g. Where installed, confirm exact locations and method of mounting outlets in modular furniture. Follow furniture manufacturers' written instructions for installing cable and devices in modular partitions. Obtain modular furniture and power pole locations from the General Contractor. Wiring locations noted in plans along walls for modular furniture are approximate and will have to be determined by Contractor at time of installation. Field condition adjustments for installation may have to be made and coordination efforts with the mechanical and electrical contractor for pathway must take place early in the project to comply with maximum 40% conduit fill factor requirements.
 - h. When requested by Owner or Owner's representative, furnish extra materials that match specified products and that are factory packaged with protective covering for storage and identified with labels describing contents. Unit pricing shall apply.
- D. Contract Administration:
- 1. Change orders shall be submitted to the Owner/Project Manager complete with price breakdown and description for approval before any work is done.
 - 2. Owner's Data Center Operations Representative will provide job field reports upon inspection of Contractor's installation, materials, supporting hardware, coordination with other trades and progress to schedule to the Owner's project manager.
 - 3. Job Field Report outline:
 - a. General installation progress in relation to scheduled work made by the Contractor up to that date.
 - b. All deficiencies noted in the cable installation to be corrected by the Contractor.
- E. Pre-Installation Meetings - Contractor shall:
- 1. Attend and/or arrange a scheduled pre-installation conference prior to beginning any work of this section.
 - a. Agenda: This venue is to ask and clarify questions in writing related to work to be performed, scheduling, coordination, etc. with consultant and/or project manager/and Data Center Operations Infrastructure Cabling representative.
 - b. Attendance: Communications project manager/supervisor shall attend meetings arranged by General Contractor, Owner's Data Center Operations Infrastructure Cabling representatives, and other parties affected by work of this document.

- c. All individuals who will be installers of communication cables and equipment in an on-site supervisory capacity shall be required to attend the pre-installation conference. Individuals who do not attend the conference will not be permitted to supervise the installation of, or install, terminate, or test communications cables on the project. This includes supervisors, project managers, and lead installers of this project.
- F. Request for Change (RFC)
 - 1. A Request for Change shall be opened and approved by the Change Approval Board prior to any modifications, attachments, or other activities that may affect production systems.
 - a. Policy and details available through the Data Center Operations Infrastructure Cable Representative.
- G. Post-Installation Meetings:
 - 1. Schedule Div. 27 Final Inspection
 - 2. At the time of substantial completion, or shortly thereafter, the low voltage Sub-Contractor shall call and arrange for a post-installation meeting to present and review all submittal documents to include, but not limited to as-built drawings, test reports, warranty documentation, etc. Attendees shall be Owner staff, Owner's Representative, General Contractor, and others that the General Contractor deems appropriate.
 - 3. At this meeting the Contractor shall present and explain all documentation, including test results, and ask for feedback on its completeness. Any discrepancies or deviations noted by and agreed to by participants shall be remedied by Contractor and resubmitted within one week of meeting.

4.2 DELIVERY, STORAGE, AND HANDLING:

- A. Coordination with delivery companies, drivers, site address, and contact person(s) will be the responsibility of the Contractor.
- B. Contractor Shall:
 - 1. Be responsible for prompt material deliveries to meet contracted completion date.
 - 2. Coordinate deliveries and submittals with the General Contractor to ensure a timely installation.
 - 3. No equipment materials shall be delivered to the job site more than three weeks prior to the commencement of its installation.
 - 4. Equipment shall be delivered in original packages with labels intact and identification clearly marked.
 - 5. Materials shall not be damaged in any way and shall comply with manufacturer's operating specifications.
 - 6. Equipment and components shall be protected from the weather, humidity, temperature variations, dirt, dust, or other contaminants. Equipment damaged prior to system acceptance shall be replaced at no cost to the Owner.
 - 7. Material Contractor shall be responsible for all handling and control of equipment.
 - 8. Material Contractor is liable for any material loss due to delivery and storage problems.
- C. Owner/General Contractor shall supply a list of security requirements for Contractor to follow.

4.3 PROJECT/SITE CONDITIONS

- A. For all environmental recommendations, refer to master Architectural section.
- B. For all security recommendations, refer to related Division 01.
- C. After completing system installation, including outlet fittings and devices, inspect exposed finish. Contractor will remove burrs, dirt, and construction debris. If applicable, the Contractor will repair damaged finishes, including chips, scratches, and abrasions.
- D. Contractor shall provide daily a clean work environment, free from trash/rubbish accumulated during and after cabling installation.

- E. Food and drink are not permitted in work areas. They shall be stored, prepared, and consumed only in designated break or cafeteria areas.
- F. Contractor shall keep all liquids (drinks, sodas, etc.) off finished floors, carpets, and tiles. If any liquid or other detriment (cuts, soils, stains, etc.) damages the above finishes, Contractor shall provide professional services to clean or repair scratched/soiled finishes, at Contractor's expense.

4.4 CLEANING

- A. Work areas will be kept in a broom clean condition throughout the duration of the installation process.
- B. Remove all unnecessary tools and equipment, unused materials, packing materials, and debris from each area where work has been performed daily, unless designated for storage.
- C. The Contractor will damp clean all surfaces prior to final acceptance by Owner.

END OF SECTION

THIS PAGE LEFT BLANK INTENTIONALLY

SECTION 270100

OPERATION AND MAINTENANCE OF COMMUNICATIONS SYSTEMS

PART 1 - GENERAL

1.1 INTRODUCTION

- A. To make the approval of such a large topic possible, the structured cable topic has been broken into its subcomponents and each subcomponent was completed, reviewed, and approved in turn. The result is this comprehensive guideline that should provide adequate guidance on this topic.

PART 2 - PRODUCT

2.1 KEY POINTS

- A. Category 6A shielded foil over unshielded twisted pair (F/UTP) is the only approved standard for cabling.
 - 1. Specifically, Siemon category CAT6A F/UTP (foil over unshielded twisted pair) cable and associated patch panels, wall plates and jacks; for data centers, and all clinical and hospital campus'.
 - 2. Only Siemon certified contractors or certified Intermountain Healthcare cable technicians will install structured cable at Intermountain Healthcare facilities.

2.2 IMPLEMENTATION

- A. This guide is to be used for New Construction and Remodels. These standards will be implemented over time in existing cabling environments as rework is performed.
- B. If there is a current need to connect servers at 10GBaseT and the only option is copper, CAT6A F/UTP is required. New Server connections shall be a minimum OS1 Single Mode Fiber.
- C. Installations already in place are not required to remove or replace existing cabling CAT5e or newer. All new cabling shall follow the recommendation to use CAT6A F/UTP cabling.

2.3 STANDARD PRODUCT

- A. The Approved cable type for horizontal cabling is CAT 6A F/UTP.
 - 1. The Approved Standard Manufacturer for Intermountain Healthcare's horizontal cabling is:
 - a. **Siemon Company USA**
101 Siemon Company Drive
Watertown, CT 06795
 - 2. Approved Suppliers of Siemon cable, patch panels, jacks, and parts are listed in Appendix 06:

PART 3 - EXECUTION

3.1 Horizontal Cabling

- A. Horizontal Subsystem is the portion of the cabling system that extends from (and includes) the work area telecommunications outlet/connector to the Floor Distributor (FD)/Horizontal Cross-connect (HC) in the telecommunications room (TDR). It consists of the communications outlet/connector, the horizontal cable, optional consolidation point, and that portion of the cross-connect in the telecommunications room serving the horizontal cable. Each floor of a building should be served by its own Floor

Distributor/Horizontal (FD/HC) Subsystem located in the telecommunications Room (TDR).

1. NOTE: Cable installers have rigorous requirements to be certified for Siemon cables and products. Validation of certification is required prior to accepting a bid.
 2. Current Siemon Approved/Certified Cable Installers for Siemon Network are listed in Appendix 07.
- B. Reliability of the horizontal cabling system is critical to the operation of IS equipment throughout a facility. Installing the cable is extremely labor intensive and there are several learned skills used to correctly install the cable. Cable installers are certified, and installers must demonstrate the ability to install the cable correctly to be certified. If the cable is installed by a certified installer and is installed in accordance with the manufacturer's guidelines, the manufacturer will warranty the cable installation.
- C. The manufacturer also requires the cables to be individually labeled and 100% tested and certified. Cable testing and certification equipment is usually expensive and is not commonly available at the facility or by many telecom installers. Certified Installer companies are required by the manufacturer to be knowledgeable in the use of "Qualified" Field Testing equipment and provide test results for warranty registration.
1. Contractor is to verify with the manufacturer the current "Qualified" tester manufacturers and the current operating software.
 2. Contractors will provide test results in the operating software format (not PDF, text or Word) to Intermountain Healthcare upon completion.
- D. Much of the cable is installed in walls and in the ceiling and usually lasts the lifespan of the building. As with most technology, the lifespan of cable is its usability and applicability to its use on future computing technology.

END OF SECTION

SECTION 270113

WARRANTY, PRODUCT AND SYSTEM

PART 1 - GENERAL

1.1 RELATED DOCUMENTS

- A. Drawings and general provisions of the Contract, including General and Supplementary Conditions and Division 01 Specification Sections, apply to this Section.
- B. Specifications throughout all Divisions of the Project Manual are directly applicable to this Section, and this Section is directly applicable to them, including but not limited to the listing found in Section 27 00 00.

PART 2 - PRODUCTS

2.1 STANDARD WARRANTY

- A. Contractor shall provide a minimum one (1) year warranty on installation and workmanship PLUS an Extended Product Warranty and System Assurance Warranty for this wiring system and shall commit to make available local support for the product and system during the Warranty period.
- B. System Certification: Upon successful completion of the installation and subsequent inspection, the customer shall be provided with a Manufacture Warranty certificate.
- C. Either a permanent link or channel model configuration may be applied to the horizontal and/or backbone sub-systems of the structured cabling system. Applications assurance is only applied to a channel model configuration. All channels are to be qualified for linear transmission performance up to 500 MHz to ensure that high-frequency voltage phase and magnitude contributions do not prove cumulative or adversely affect channel performance.

2.2 EXTENDED WARRANTY

- A. The manufacturer of passive telecommunications equipment used in a manner not associated with the Systems Warranty must have a minimum five (5) year Component Warranty on all its product. The Products Warranty covers the components against defects in material or workmanship under normal and proper use.
 - 1. Special Project Warranty: A full end-to-end written warranty mutually executed by manufacturer and the principal Installer, agreeing to replace and install voice/data distribution system components that fail in materials or workmanship, or do not meet manufacturer's official published specifications and performance criteria within the special Project warranty period specified below. This shall cover applications assurance, cable, and connecting hardware including both labor and materials. This warranty shall be in addition to, and not a limitation of, other rights and remedies the Owner may have against the Contractor under the Contract Documents.
- B. A twenty (20) year warranty available for the Category 6A Z-MAX copper structured cabling system shall be provided for an end-to-end channel model installation which covers applications assurance, cable, connecting hardware and the labor cost for the repair or replacement thereof. The fiber warranty will be an XGLO twenty (20) year warranty, which is based on using laser optimized single mode fiber as minimum.
 - 1. Performance claims based on worst case testing and channel configurations.
 - 2. Special Project Warranty Period: 20 years minimum, beginning on the date of Substantial Completion.
 - 3. Siemon Certified Warranty Requirements:

- a. Upon Completion of the project, Intermountain Healthcare must receive the Full Warranty Documentation from The Siemon Company before final retention funds are released to the general contractor, electrical contractor and structured cabling subcontractor if applicable.

2.3 MAINTENANCE

- A. Support Availability: The Contractor shall commit to make available local support for the product and system during the Warranty or Extended Warranty period.

END OF SECTION

SECTION 270119

FIELD TESTING AND REPORTING

PART 1 - GENERAL

1.1 RELATED DOCUMENTS

- A. Drawings and general provisions of the Contract, including General and Supplementary Conditions and Division 01 Specification Sections, apply to this Section.
- B. Specifications throughout all Divisions of the Project Manual are directly applicable to this Section, and this Section is directly applicable to them, including but not limited to the listing found in Section 27 00 00.

1.2 SYSTEM DESCRIPTION

- A. Owner reserves the right to be present during any or all testing.
- B. The objective of this project is to provide a complete communications cabling infrastructure system installation including, but not limited to: fiber backbone, riser system, horizontal data and voice cabling with associated terminations, mounting equipment, cable pathway and management systems, testing and other items/materials, as specified in drawings, these specifications, and contract documents.
- C. The Contractor's BICSI Registered Communications Distribution Designer (RCDD) supervisor shall review, approve and stamp all documents prior to submitting. The Contractor's RCDD shall warrant in writing that 100% of the installation meets the requirements specified herein upon completion of all work.
- D. Product Certificates shall be signed by manufacturers of cables, connectors, and terminal equipment certifying that products furnished comply with requirements.
- E. Contractor shall submit the required Field Test Reports in the format and media specified, upon completion of testing the installed system.
- F. Contractor shall deliver manufacturer's signed long-term Warranty of installed cabling system to include all components that comprise the complete cabling system. Delivery to be affected within two weeks of the time of final punch list review. Failure of any component to pass system component tests shall be promptly corrected, repaired or replaced to meet standards compliance.

1.3 PREFERRED OWNER INSPECTION & TEST CHECKPOINTS

- A. DCO & ICT Inspection Milestones & Responsibilities need to be coordinated into master project plan to allow the GC to make timely arrangements. All are per floor and/or phase.
 - 1. ICT & DCO = Framing, during and/or after boxes & conduits are in place; prior to sheetrock.
 - 2. ICT = When cable basket is starting to be installed.
 - 3. ICT = When cable basket is ready, but prior to starting to pull cable.
 - 4. ICT & DCO = When TDR's are ready for racks and ladders.
 - 5. DCO = When anchoring racks and laying out equipment.
 - 6. ICT & DCO = When TDR environmental requirements are ready, room is dust free, and securable.
 - a. The TEC and TDRs must be high on the build timeline and be completed early in the construction to accommodate the building systems to be tested and commissioned, such as BAS, Security, and Wireless Network.
 - 7. ICT = When trim and testing are in progress.
 - 8. OTHERS
 - a. Depending on project, the manufacturer will inspect 1 or 2 times.
 - b. DCO or ICT = When problems or questions arise.

PART 2 - PRODUCTS

2.1 SITE TESTS & INSPECTIONS

- A. Prior to pulling cable, the cabling contractor shall schedule an inspection of the pathways with a member of the Data Center Operations Infrastructure cabling team.
- B. Upon completion of the communications infrastructure systems, including all pathways and grounding, the Contractor shall test the system.
 - 1. Cables and termination modules shall be affixed, mounted or installed to the designed/specified permanent location prior to testing.
 - 2. Any removal and reinstallation of any component in a circuit, including faceplates, shall require retesting of that circuit and any other disturbed or affected circuits.
 - 3. Approved instruments, apparatus, services, and qualified personnel shall be utilized.
 - 4. If tests fail, Contractor shall correct as required to produce a legitimate passing test.
 - 5. Manipulation of tester parameters on a failing test in order to achieve a passing test is unacceptable.
- C. These specifications will be strictly enforced. The Contractor must verify that the requirements of the specifications are fully met through testing with an approved tester (rated for testing the cable type in use), and documentation as specified below. This includes confirmation of requirements by demonstration, testing and inspection. Demonstration shall be provided at final walk-through in soft copy.
- D. Notification of the likelihood of a cable exceeding standardized lengths must be made prior to installation of the cable. Without contractor's prior written notice and written approval by the Owner, testing that shows some or all pairs of cable not meeting specifications, shall be replaced at Contractor's expense (including respective connectors).
- E. Testing is still required for non-compliant cabling. The tests shall be for wire-mapping, opens, cable-pair shorts, and shorts-to-ground. The test results must be within acceptable tolerances and shall be submitted with the Owner's acceptance document.

2.2 CABLE TESTING PLAN

- A. The Contractor shall:
 - 1. Provide a complete and detailed test plan for approval of the cabling system specified herein, including a complete list of test equipment for copper and fiber optic components and accessories prior to beginning cable testing. The following minimal items shall be submitted for review:
 - a. All testing methods that clearly describes procedures and methods.
 - b. Product data for test equipment
 - c. Certifications and qualifications of all persons conducting the testing.
 - d. Calibration certificates indicating that equipment calibration meets National Institute of Standards and Technology (NIST) standards and has been calibrated at least once in the previous year of the testing date.
 - 2. Include validation, and testing. Owner will require that the telecommunications cabling system installed by the Contractor be fully certified to meet all necessary requirements to be compliant with referenced IEEE and TIA specifications and vendor's warranty.
 - 3. Will determine the source/cause of test failure readings and correct malfunctioning component and/or workmanship within each channel or permanent link and retest to demonstrate compliance until corrected failure produces a passing result.

2.3 CABLE TESTING REPORTS

- A. The Contractor shall submit cable test reports as follows:
 - 1. Submit certified test reports of Contractor-performed tests.
 - a. The tests shall clearly demonstrate that the media and its components fully comply with the requirements specified herein.

- b. (1) set of electronic test reports shall be submitted and clearly identified with cable identification.

PART 3 - EXECUTION

3.1 TEST EQUIPMENT

- A. All transmission testing of balanced twisted-pair cables shall be performed with an approved Level III balance twisted pair tester found on the Siemon Ally Website. The latest version of software shall be installed prior to performing testing. Refer to the Siemon Warranty Documents for proper testing requirements of associated cable and components.
- B. All balanced twisted-pair field testers shall be factory calibrated each calendar year by the field test equipment manufacturer as stipulated by the manuals provided with the field test unit. The calibration certificate shall be provided for review prior to the start of testing
- C. Auto test settings provided in the field tester for testing the installed cabling shall be set to the default parameters
- D. Test settings selected from options provided in the field testers shall be compatible with the installed cable under test.

3.2 TEST METHOD / CRITERIA

- A. Copper Testing
 - 1. Testing of all newly installed cable channels shall be performed prior to system cutover.
 - a. Visually inspect F/UTP and optical fiber cable jacket materials for NRTL certification markings. Inspect cabling terminations in communications equipment rooms for compliance with color-coding for pin assignments and inspect cabling connections for compliance with TIA/EIA-568-C.1.
 - b. Visually confirm Category 6A marking of outlets, cover plates, outlet/connectors, and patch panels.
 - c. Visually inspect cable placement, cable termination, grounding and bonding, equipment and patch cords, and labeling of all components.
 - d. Test F/UTP copper cabling for DC loop resistance, shorts, opens, intermittent faults, and polarity between conductors. Test operation of shorting bars in connection blocks. Test cables after termination but not cross-connection.
 - e. Test instruments shall meet or exceed applicable requirements in TIA/EIA-568-C, and those required by manufacturer to validate and start warranty.
 - 2. Copper Testing all 500 MHz category 6A field-testing shall be performed with an approved level 111e balanced twisted-pair field test device, that complies with performance requirements in "Test Instruments (Normative)" Annex, complying with measurement accuracy specified in "Measurement Accuracy (Informative)" Annex (Level IIe or IIIe balanced twisted pair field test device). Use only test cords and adapters that are qualified by test equipment manufacturer for channel or link test configuration.
 - 3. All installed 500 MHz category 6A channels shall perform equal to or better than the minimum requirements as specified below:
 - a. Category 3, balanced twisted-pair backbone cables, for the channel shall be 100 percent tested according to ANSI/TIA/EIA-568-C.1. Test parameters include wire map plus F/UTP (ScTP) shield continuity (when present), insertion loss, length and NEXT loss (pair-to-pair). NEXT testing shall be done in both directions.
 - b. 500 MHZ Category 6A balanced twisted-pair horizontal and backbone cables, shall be 100 percent tested.
 - 4. F/UTP Performance Tests
 - a. Wire map.

- b. Length (physical vs. electrical, and length requirements)
 - c. Insertion loss
 - d. Near-end crosstalk (NEXT) loss
 - e. Power sum near-end crosstalk (PSNEXT) loss
 - f. Equal-level far-end crosstalk (ELFEXT)
 - g. Power sum equal-level far-end crosstalk (PSELFEXT)
 - h. Return loss
 - i. Propagation delay
 - j. Delay skew
 - k. F/UTP Shield continuity
5. Final Verification Tests: Perform verification tests for F/UTP systems after the complete communications cabling and workstation outlet/connectors are installed.
 6. Document data for each measurement. Data for submittals shall be printed in a summary report.
 7. End-to-end cabling will be considered defective if it does not pass tests and inspections.
 8. Prepare and submit test and inspection reports.
- B. Horizontal Fiber Testing
1. Fiber horizontal cables shall be 100% tested for insertion loss and length.
 2. Insertion loss shall be tested at 850 nm or 1300 nm for 50/125 μ m and 62.5/125 μ m multimode cabling in at least one direction using the Method B (1-jumper) test procedure as specified in ANSI/TIA/EIA-526-14A.
 3. Length shall be tested using an OTDR, optical length test measurement device or sequential cable measurement markings.
 4. The horizontal link performance guarantees are based on an optical fiber calculation for the appropriate fiber solution. Optical fiber calculations shall be determined using the Siemon Fiber Loss Calculator found on the Siemon Ally Website.
- C. Backbone Fiber Testing
1. Fiber backbone cables shall be 100% tested for insertion loss.
 2. Insertion loss shall be tested at both 850 nm and 1300 nm for 50/125 μ m and 62.5/125 μ m multimode cabling and both 1310 nm and 1550 nm for 8.5/125 μ m single mode cabling and in at least one direction using the Method B (1-jumper) test procedure as specified in ANSI/TIA/EIA-526-14A.
 3. Insertion loss shall be tested at 1310 and 1550 for single-mode cabling in at least one direction using the Method A.1 (1-jumper) test procedure as specified in ANSI/TIA/EIA-526-7.
 4. Length shall be tested using an OTDR, optical length test measurement device or sequential cable measurement markings.
 5. The backbone link performance guarantees are based on an optical fiber calculation for the appropriate fiber solution. Optical fiber calculations for any fiber cable greater than 90m (295 ft.) shall be determined using the Siemon Fiber Loss Calculator found on the Siemon Ally Website.

3.3 DEMONSTRATION

- A. Include training for appropriate IT staff in numbering system and documentation system methods and record keeping. Proper fiber terminations and fiber jumper installations.

END OF SECTION

SECTION 270133

SHOP DRAWINGS, PRODUCT DATA, SAMPLES DESIGN RECORDS & EXISTING CONDITIONS

PART 1 - SHOP DRAWINGS, PRODUCT DATA, AND SAMPLES

1.1 SUBMITTALS

- A. The Contractor:
 - 1. Shall not perform any portion of the work requiring submittal and review of shop drawings, product data, or samples until Owner has approved the respective submittal. Such work shall be in accordance with approved submittals.
 - a. Shop drawings as required by the owner or as a minimum to include a minimum of two sets of a plan view and elevations of all work to be installed. The Contractor shall make any corrections required by the owner or the owner's representative or consultant team, file with him two corrected copies and furnish such other copies as may be needed. The consultant's approval of such drawings or schedules shall not relieve the Contractor from responsibility for deviations from drawings or specifications, unless he has in writing and called to the Architect's attention such deviations at the time of submission, nor shall it relieve him from responsibility for errors of any sort in shop drawings or schedules.
- B. The Contractor shall provide a copy of the Certified Test Data Sheet, available from the delivering distribution warehouse for either a full run or cut piece from the Master Reel of the fiber cable to be installed
 - 1. The Certified Test Data Sheet shall include the Master Reel number, cable description, a passing test result with details, test equipment description, date certified, and a certificate of compliance stamp, and shall be included in the O&M Manual as a component of the final deliverables submittal package.

1.2 DRAWINGS

- A. Shop Drawings
 - 1. The Contractor shall:
 - a. Submit catalogue cut sheets that include manufacturer, trade name, and complete model number for each product specified. Model number shall be handwritten, marked with an arrow or underlined to indicate exact selection.
 - b. Identify applicable specification section reference for each product performance for each component specified for approval prior to purchase and installation.
- B. Record Drawings
 - 1. Drawings for the cabling system infrastructure elements shall be maintained and kept on file by the Siemon Certified Installer (Company) for the entire term of the warranty. Drawings shall include:
 - a. Horizontal cable routing and terminations
 - b. Telecommunications outlets/connectors
 - c. Backbone cable routing and terminations
 - d. Telecommunication Spaces (TS)
- C. Samples
 - 1. For workstation outlet connectors, jack assemblies, housing and faceplates for color selection and evaluation of technical specifications and requirements. Confirm with Architect, interior designer, and Owner representative for color before purchasing materials. Face plates shall match the electrical face plates in

2. Color and material type.
 2. Upon request, provide samples for workstation outlets, jacks, jack assemblies, in specified finish, one for each size and outlet configuration
 3. Sample mock-up rooms may be required in some areas to ensure proper equipment placement and fit.
- D. Qualifications:
1. The Contractor shall provide the appropriate documentation to comply with the requirements set forth in Section 01 43 23 Qualifications, included with, and at the time of, bid submittal.

PART 2 - SUSTAINABLE DESIGN RECORDS AND REPORTS

2.1 DRAWINGS

- A. Closeout Submittals (As-built Drawings):
1. Communications Design drawings are to be supplied to the Architect to prepare the master "As-Built" drawings.
 2. As-Built drawings shall be in a format that is compatible with the format used by the Architect and consultant. Dimensions and scale of the drawing sheets submitted shall match the size of the drawing used for the contract documents and shall include the cable numbers labeled in accordance with this document.
 3. Utilize normal recognized drafting procedures that match standards, Architect and consultant guidelines and methodology.
 4. The As-Built drawings shall incorporate all changes made to the building identified in, but not limited to, addendum, change notices, site instructions or deviations resulting from site conditions.
- B. Contractor shall:
1. Clearly identify any resubmitted drawing sheets, documents or cut sheets either by using a color to highlight or cloud around resubmitted information.
 2. Maintain drawing numbering or page/sheet scheme consistency as per previously issued drawings/documents.
 3. Provide dimensioned plan and elevation views of networking components, showing:
 - a. All communications data/voice outlet locations complete with outlet/cable labeling.
 - b. Cable routing paths of communications cables to identified infrastructure pathways.
 - c. All rack and cabinet locations and labeling thereof.
 - d. One-line diagram of equipment/device interconnecting data/voice cabling of the data and voice systems.
 - e. Standard or typical installation details of installations unique to Owner's requirements.
 - f. Graphic symbols and component identification on detail drawing shall conform to the latest ANSI/TIA 568-C, ANSI/TIA 569-B, ANSI/TIA 606-A and ANSI/NECA/BICSI 607-A conventions.
 4. Submit one soft (compatible with Microsoft software) and hard copy with project deliverables within three weeks subsequent to substantial completion.
 5. Hard copy of floor plans for record shall be plotted to a standard, saleable, identified drawing scale.

2.2 RECORDS AND REPORTS

- A. All records shall be created by the installation contractor and turned over at the completion of work.
1. The format shall be computer based
 - a. Soft copies and hard copies shall be part of the As-built package.
 - b. The minimum requirements include:

- 1) Cable records must contain the identifier, cable type, termination positions at both ends, splice information as well as any damaged pairs/conductors.
 - 2) Connecting hardware and connecting hardware position records must contain the identifier, type, damaged position numbers, and references to the cable identifier attached to it.
2. Test documentation on all cable types shall be included as part of the As-built package.
- B. All Siemon Warranty Registration documents shall be included.
 - C. All reports shall be generated from the computer-based program used to create the records above. These reports should include but not limited to:
 1. Cable Reports
 2. Cross-connect Reports
 3. Connecting Hardware Reports

PART 3 - EXISTING CONDITIONS SITE SURVEY

3.1 SITE SURVEY

- A. Prior to placing any cable pathways or cable, the contractor shall survey the site to determine job conditions will not impose any obstructions that would interfere with
- B. the safe and satisfactory placement of the cables. The arrangements to remove any obstructions with the Project Manager need to be determined at that time.

END OF SECTION

THIS PAGE LEFT BLANK INTENTIONALLY

SECTION 270143

QUALIFICATIONS AND REQUIRED TRAINING FOR CONTRACTORS AND INSTALLERS

PART 1 - GENERAL INSTALLER QUALIFICATIONS

1.1 ENTITIES

- A. Communications contractors
 - 1. The Communications Contractor shall at a minimum possess the following qualifications:
 - a. Contractor shall be a Siemon Certified Contractor with valid up to date contract certification and in good standing with the Siemon Company.
 - b. Be in business a minimum of five (5) years.
 - c. Contractor shall demonstrate satisfaction of sound financial condition and can be adequately bonded and insured if the project deems necessary.
 - d. Possess those licenses/permits required to perform telecommunications installations in the specified jurisdiction.
 - e. Use personnel knowledgeable in local, state, province and national codes and regulations. All work shall comply with the latest revision of the codes or regulations. When conflict exists between local or national codes or regulations, the most stringent codes or regulations shall be followed.
 - 2. Contractor must possess current liability and workers compensation insurance certificates.
 - 3. Contractor must be registered with BICSI and have at least one RCDD on staff or ITS Cabling Installer Program Technician certification and Installer Level 1 & 2 for a minimum of 75 percent of staff.

1.2 TRAINING

- A. The Contractor shall be fully conversant and capable in the cabling of low voltage applications such as, but not limited to data, voice and imaging network systems. The Contractor shall at a minimum possess the following qualifications:
 - 1. Personnel trained and certified in the design of the Siemon Cabling System®.
 - 2. Personnel trained and certified to install the Siemon Cabling System®.
 - 3. The Designer and Installer shall show proof of current certification of the Siemon Cabling System® via an updated certificate given after attending the Certified Installer training course or an on-line re-certification class given every two years.
 - 4. Provide references of the type of installation provided in this specification.
 - 5. Personnel trained and certified in the installation of copper cable and in the use of Level IIIe Copper Transmission Performance testers, fiber optic cabling, splicing, termination and testing techniques. Personnel must have experience using an optical light source and power meter plus an OTDR.
 - 6. Personnel trained in the installation of pathways and supports for housing horizontal and backbone cabling.
- B. Facilities Orientation

END OF SECTION

SECTION 270171

RESPONSIBILITY AND WORKMANSHIP OF CONTRACTOR

PART 1 - GENERAL

1.1 CONTRACTOR RESPONSIBILITY

- A. Contractor shall be obligated to exercise the highest standard of care in performing its obligations as defined in a request for proposal. All work shall be done in a workman like fashion of the highest standards in the telecommunications industry.
- B. All equipment and materials are to be installed in a neat and secure manner, while cables are to be properly dressed in accordance with standards recommendation for a specific type of media (i.e. UTP vs. F/UTP @ 10 Gigabit)
- C. Workers must clean any debris and trash at the close of each job and workday.
- D. Contractor acknowledges that Intermountain Healthcare will rely on contractor's expertise, ability and knowledge of the system being proposed and shall be obligated to exercise the highest standard of care in performing contractual obligation as defined in the Scope of Work.
- E. Contractor must submit The Siemon warranty, Cable Records, As Built Drawings and Test Results at the completion of work. Note: Intermountain Healthcare reserves the right to withhold final payments until all registration documents are approved by the Siemon Company and received by Intermountain Healthcare.

1.2 CONTRACTOR AND EMPLOYEE RESPONSIBILITY

- A. Contractors, their employees, and installers will attend annually Intermountain Healthcare required Infection Control training.
- B. Contractors, their employees, and installers will complete Reptrax registration.
- C. Contractors, their employees, and installers will attend Intermountain Healthcare required site and job specific orientation.
- D. Contractors, their employees, and installers will maintain Intermountain Healthcare required immunizations.
- E. Contractors, their employees, and installers will keep their Intermountain Healthcare required confidentiality agreements current.
- F. Contractors, their employees, and installers always agree to follow all Intermountain Healthcare Policies and procedures and wear the appropriate ID while on any of Intermountain properties.
- G. Contractor will determine with Owner the appropriate level of Environmental Containment precautions to utilize for each work location. Infection Control Risk Assessments and permits will be performed as required.
- H. Upon request, provide qualification data for all qualified layout technicians, installation supervisors, and field inspector
 - 1. Siemon issued qualification badges shall be readily available for this purpose.

1.3 EXAMINATION

- A. Field Measurements: Verify dimensions in areas of installation by field measurements before fabrication and indicate measurements on shop drawings. Coordinate fabrication schedule with construction progress to avoid delaying the work.
- B. Established Dimensions: Where field measurements cannot be made without delaying the work, establish dimensions and proceed with fabricating units without field measurements. Coordinate supports, adjacent construction, and fixture locations to ensure actual dimensions correspond to established dimensions.

1.4 PREPARATION

- A. Pre-installation inspection
 - 1. The Contractor shall visually inspect all cables, cable reels, and shipping cartons to detect possible cable damage incurred during shipping and transport. Visibly damaged goods are not acceptable and shall be replaced by the contractor at no additional cost to the Owner.

1.5 MISCELLANEOUS CONTRACTOR RESPONSIBILITIES

- A. Contractor will maintain unobstructed egress in work areas.
- B. Contractor will keep an access for all Emergency Services.
- C. Contractor will maintain training for Personnel in alternate exits if needed.
- D. Contractor will maintain Temporary construction partitions, as required, that are smoke tight and built of non-combustible materials.
- E. Additional Fire Extinguishers may be required and will be properly maintained and inspected.
- F. Construction site will be maintained clean and orderly.
- G. Contractor will observe Intermountain Healthcare's Tobacco Use Policy. (All forms of tobacco use are strictly prohibited)
- H. All Electrical Extension cords will be grounded, and in good condition and, plugged into approved GFI Receptacles.
- I. Construction site will be restricted. (Approved personnel Only)
- J. Required Personal Protective Equipment (PPE) will be worn as required. (i.e. hard hats, safety glasses, safety shoes, fluorescent vest, in accordance with general contractor's safety policy)
- K. Tools will be unplugged, and power secured at the end of each working day.
- L. All employees and contractors will understand how to obtain MSDS sheets.
- M. Contractor will notify proper personnel of any fire system shut down. A 48-hour notification is required.
- N. Contractor will address all vibration concerns with Intermountain Healthcare and general contractor's staff.
- O. Contractor will address all Noise Issues with Intermountain Healthcare and general contractor's staff.
- P. Contractor will fill out a Hot Work permit and keep it on site daily as needed.
- Q. Contractor will fill out an Above Ceiling Work Permit and keep it on site daily as needed.
- R. Contractor will obtain a Confined Space Permit, when required, and keep it on site.
- S. Contractor shall notify Information Systems 72 hours in advance of any shutdown or known interruption of required environmental services. Follow up by notifying the Service Desk.
- T. Demolition of low voltage cabling shall be performed by the Low Voltage installation contractor.
 - 1. To prevent accidental removal of in-use circuits.
 - 2. To allow for re-use of circuits where practical.

END OF SECTION

SECTION 270500

COMMON WORK RESULTS FOR COMMUNICATIONS

PART 1 - PRODUCT

1.1 SUMMARY

- A. This section covers general work results for all Communications Division detail subsections.
- B. Work of the following sections cover a complete installation of both permanent and channel links for a data and voice communications network utilizing copper and fiber transmission media.

PART 2 - EXECUTION

2.1 SCOPE OF WORK

- A. Includes, but is not limited to the following.
 - 1. The Contractor shall:
 - a. Provide and install fabric and/or either plenum, PE or PVC Innerduct, rated appropriately for the installation environment; in accordance with all applicable codes and ordinances.
 - b. Provide, install, terminate, test, label and document all fiber backbone, fiber and copper riser cable.
 - c. Provide, install, terminate, test, and document all fiber, copper voice, and data horizontal cable.
 - 1) CAT6A UTP and CAT6A F/UTP shall not be mixed on the same campus.
 - d. Provide and place all termination devices such as, but not limited to, modular patch panels, termination blocks, information outlets (jacks and plates), phone jacks, fiber distribution panels, bulkheads, connectors, and fiber fan out kits.
 - e. Provide in quantities specified interconnect components such as, but not limited to, copper patch cords, fiber patch cables and data station cables.

- f. Provide and place horizontal and vertical cable support devices such as, but not limited to, rack and wall-mounted horizontal and vertical cable management, cable runway, communications cable runway, and all required mounting hardware, unless otherwise noted.
- g. Provide and install all equipment mounting racks, cabinets and/or brackets.
- h. Provide and install UL-approved fire stopping systems in all communication pass-thru, conduits, cable trays and ceiling, wall and floor penetrations in coordination with General Contractor.
- i. Provide all appropriate consumable items required to complete the installation.
- j. Grounding and bonding in TEC and TR rooms to grounding bus provided by Division 26.
- k. Provide complete documentation and demonstration of work.
- l. Completion of all punch list deficiencies within 10 working days.
- m. Provide indexed and organized complete Test Results of all copper and fiber cable and their components.
- n. Provide Submittals.

- o. Conduct a final document handover meeting with client, consultant, and PM to review, discuss and educate the Owner on the test results and As-Built Drawings.
- p. Provide a Manufacturer's Extended Product Warranty and System Assurance Warranty for this wiring system.

END OF SECTION

SECTION 270526

GROUNDING AND BONDING FOR COMMUNICATIONS SYSTEMS

PART 1 - GENERAL

1.1 RELATED DOCUMENTS

- A. This work shall be provided by Division 26.
 - 1. Division 26 shall provide and install the communications system grounding bus bar.
 - 2. Systems other than the voice/data system shall be bonded by their respective installers or Division 26.
- B. Exception: Division 27 shall bond racks, ladders, and other conductive IT equipment and enclosures as required.
- C. Requirements of the following Division 26 Sections apply to this section:
 - 1. Basic Electrical Requirements
 - 2. Basic Electrical Materials and Methods
 - 3. Grounding and Bonding for Electrical Systems

1.2 SUMMARY

- A. This Section includes methods and materials for grounding and bonding Communications systems.
- B. All grounding / earthing and bonding shall be done to applicable codes and regulations. It is recommended that the requirements of IEC/TR 61000-5-2: 1.0, ANSI-J-STD-607-A, or both be observed throughout the entire cabling system.

PART 2 - PRODUCTS

2.1 CONDUCTORS

- A. Insulated Conductors: Copper wire or cable insulated for 600 V unless otherwise required by applicable Code or authorities having jurisdiction.
 - 1. Stranded conductors No. 6 AWG.

2.2 CONNECTORS

- A. Listed and labeled by a nationally recognized testing laboratory acceptable to authorities having jurisdiction for applications in which used, and for specific types, sizes, and combinations of conductors and other items connected.
- B. Compression fitting – 2-hole strap.

PART 3 - EXECUTION

3.1 QUALITY ASSURANCE

- A. Electrical Components, Devices, and Accessories: Listed and labeled as defined in NFPA 70 (NEC), Article 100, by a testing agency acceptable to authorities having jurisdiction, and marked for intended use.
- B. Comply with UL 467 for grounding and bonding materials and equipment.

3.2 APPLICATIONS

- A. Conductors: Install stranded conductors for No. 6 AWG and larger, unless otherwise indicated.

3.3 INSTALLATION

- A. Grounding Conductors
 - 1. Route along shortest and straightest paths possible, unless otherwise indicated or required by Code.
 - 2. Avoid obstructing access or placing conductors where they may be subjected to strain, impact, or damage.
 - a. Jumper across all tray junctions use two-hole crimp lugs with a bolt, lock washer and nut to prevent loosening of ground connections over time.
 - b. Contractor to remove small area of powder coat or paint to create a metal to metal bonding connection.
 - c. Per current BICSI TDMM "Grounding, Bonding and Electrical Protection":
 - 1) Grounding and bonding connectors should be one of the following: Tin plated copper, copper or copper alloy
 - 2) Connections should be made using crimp connectors, or exothermic welding.
 - d. Per TIA/EIA 607-A the TBB (Telecommunications Bonding Backbone) connections "shall be made using irreversible compression-type connectors, exothermic welding or equivalent."

END OF SECTION

SECTION 270528

PATHWAYS FOR COMMUNICATONS SYSTEMS

PART 1 - GENERAL

1.1 RELATED DOCUMENTS

- A. Main pathways for communications systems shall be the responsibility of the Division 27 low voltage contract.
 - 1. Includes, but is not limited to, hangars, supports, J-hooks and cable tray.
 - 2. Sections 270536, 270539, and 270543_46, are supplemental clarifications that are additions to this section. The appropriate section(s) shall add for the material used.
- B. Conduits, pathways, and boxes which are embedded within building finishes for communications systems shall be the responsibility of the Division 26 electrical contractor
- C. Requirements of the following Division 26 sections apply to this section
 - 1. Basic electrical requirements
 - 2. Basic electrical materials and methods
 - 3. Grounding, earthing, and bonding for electrical systems

1.2 SUMMARY

- A. Contractor shall install work following specifications, drawings, manufacturer's instructions and approved submittal data.

PART 2 - PRODUCTS

2.1 CABLE PATHWAYS

- A. Comply with TIA/EIA-569-B.
- B. Pathways shall be designed and installed to meet applicable local and national building and electrical codes or regulations.
 - 1. All materials shall be UL- and/or CSA and/or ETL-approved and labeled in accordance with NEC for all products where labeling service normally applies.
 - 2. NRTL labeled for support of Category 6A cabling, designed to prevent degradation of cable performance and pinch points that could damage cable
 - 3. Materials and equipment requiring UL 94, 149 or 1863 listing shall be so labeled. Modification of products that nullifies UL labels are not permitted.
 - 4. The installed systems shall not generate, nor be susceptible to any harmful electromagnetic emission, radiation, or induction that degrades, or obstructs any equipment.
- C. Pathways consist of conduit, basket tray/ladder rack, J-hooks, surface mounted raceway and power poles.
 - 1. Basket tray shall be utilized for distribution pathways
 - a. Provides proper support and load distribution along pathways.
 - b. Flexibility, scalability, and accessibility
 - c. Ladder rack shall be used in data rooms.
 - 2. Conduits may be utilized where cable tray is not viable, providing the cross-sectional area of the conduit is greater than the cross-sectional area of the cable tray.
 - 3. J-hooks are the minimum pathway device required for all low voltage contractors for use in ceiling distribution.
 - a. Refer to section 270529.
 - 4. Note: Surface mounted raceway and power poles should be installed only when

other pathway choices are not feasible.

2.2 EQUIPMENT

- A. Compatibility
 - 1. All material and equipment as provided should be the standard Commercial-Off-The-Shelf (COTS) products of a manufacturer engaged in the manufacturing of such products. All shall be typical commercial designs that comply with the requirements specified. All material and equipment shall be readily available through manufacturers and/or distributors.
 - a. All equipment shall be standard catalogued items of the manufacturer and shall be supplied complete with any optional items required for proper installation.
 - b. Coordinate the features of materials and equipment so they form an integrated system. Match components and interconnections for optimum future performance and backward compatibility
- B. Horizontal cables shall be installed in “clean, dry” locations that provide protection from moisture levels above the intended operating range of inside plant (ISP) cables
 - 1. Cable pathways shall be installed to provide protection from the elements (i.e. moisture) and other hazards.
 - 2. Cables and cable pathways shall be protected from detritus elements such as paints, adhesives, water and cleaners.
 - a. In case of contamination, cables shall be replaced at the General Contractors expense. Cleaning is not acceptable.
 - 3. Pathways shall not have exposed sharp edges that may come into contact with telecommunications cables.
- C. Pathways shall not be in elevator shafts.
- D. Grounding / Earthing and bonding of pathways shall comply with applicable codes and regulations. It is recommended that the requirements of IEC/TR3 61000-5-2 - Ed. 1.0, ANSI-J-STD-607-B, or both be observed throughout the entire cabling system.

2.3 SURFACE MOUNTING

- A. Surface Mount Cable Runs and Faceplate Boxes
 - 1. Surface mounting of cable pathway runs and/or boxes for outlets/faceplates are only authorized as a last resort and exception to running cables through the wall and above the ceiling.
 - 2. If surface mount cable runs are used:
 - a. Burrs will be removed from the inside of the plastic or metal surface mount pathway to prevent damage to cables pulled through the run.
 - b. Raceway manufacturer plastic bushings shall be installed at all outlet openings in raceway to prevent damage to cable.
 - c. “T”, Splice, and corner pieces will be used to join runs. Runs will not be butted together without the appropriate joining pieces.

PART 3 - EXECUTION

3.1 HORIZONTAL PARAMETERS

- A. Allowable Cable Bend Radius and Pull Tension:
 - 1. In general, communications cable cannot tolerate sharp bends or excessive pull tension during installation.
 - a. Bend radius for 4 pair UTP and F/UTP under no load (no pulling tension) shall not exceed four (4) times the outside diameter of the cable and eight (8) times the outside diameter of the cable under load (110N/25lbf). Note: Cable bend radius and pulling tensions for cables other than 4 pair cable increase with the diameter and type of cable refer to the manufacturer’s recommendations for specific requirements.
 - 2. After installation, exposed cable and other surfaces must be cleaned free of lubricant residue. Use only lubricants specifically designed for cable installation.

- B. Pull Strings:
 - 1. Horizontal and Vertical Pathways
 - a. The pathway installer shall:
 - 1) Provide pull strings in all new conduits, including all conduits with cable installed as part of this contract.
 - 2) Provide pull strings in all new cable trays.
 - 3) Pull string shall have a rated average breaking strength of 200 pounds.
 - 4) During pulling sessions, pull strings must move freely to prevent cable jacket/cable damage.
 - 5) Free moving pull strings shall be provided in all locations where they are utilized as part of this contract.
- C. Conduit Fill:
 - 1. Reference manufacturer's Design Installation Guidelines manual.
 - 2. Comply with requirements of NFPA 70 (NEC)
 - 3. The number of cables placed in a pathway shall not exceed manufacture specifications, nor, will the geometric shape of a cable be affected.
 - a. Conduit pathways shall have a maximum fill ratio of 40% to allow for proper pulling tension and lay of the CAT6A F/UTP cable. A minimum of a 1" diameter conduit is required for new construction. Existing conduits will require the reduction of the number of cables placed in the conduit to meet the required fill ratio.

3.2 INTRA-BUILDING CABLE ROUTING

- A. Pathways
 - 1. The backbone subsystem shall include cable installed in a vertical manner between floor telecommunications rooms and the main or intermediate cross-connect in a multi-story building and cable installed horizontally between telecommunications rooms and the main or intermediate cross-connect in a long single-story building.
 - 2. Adequate riser sleeve/slot space shall be available with the ability to ingress the area later in all telecommunications rooms, such that no drilling of additional sleeves/slots is necessary. Proper fire stopping is required for all sleeves/slots per national and local codes. Install fire stop material designed specifically for the building construction conditions and to meet the existing fire stop material as directed by the building engineer.
 - 3. Backbone pathways shall be installed or selected such that the minimum bend radius of backbone cables is kept within manufacturer specifications both during and after installation.
 - 4. Where redundant paths are required, they shall be separated by a minimum of 24".
 - a. Separate innerducts and/or armored fiber are required for each leg of the redundant path.
 - b. Separate physical routing for each path shall be utilized where possible.
 - 5. Building backbone cables shall be installed in "dry" locations that provide protection from moisture levels above the intended operating range of inside plant (ISP) cables. "Slab-on-Grade" building designs wherein pathways are installed underground on/in the poured concrete slabs that are in direct contact with the soil are considered wet locations and hence are not permitted.

END OF SECTION

THIS PAGE LEFT BLANK INTENTIONALLY

SECTION 270529

HANGERS AND SUPPORTS FOR COMMUNICATION SYSTEMS

PART 1 - PRODUCTS

1.1 APPROVED PRODUCT

- A. The J-hooks shall meet or exceed the below characteristics of construction and features
 - 1. Provide broad based support for cabling to aid in maintaining overall system performance.
 - 2. Be available in 50.8mm (2") and 101.6mm (4") options
 - 3. Come equipped with a cable retention clip
 - 4. Offers a full line of mounting accessories.

1.2 APPROVED MANUFACTURERS

- A. Ericson / Caddy
- B. B-Line
- C. Stiffy

PART 2 - EXECUTION

2.1 J-HOOKS AND OTHER SUPPORTS SHALL BE INSTALLED SUCH THAT THEY:

- A. Shall be supported with devices designed for this purpose and shall be installed independently of any other structural component. J-Hooks shall not use the suspended ceiling support wires or lighting fixture support wires.
- B. The number of cables placed into the J-hooks shall be limited to a number that will not cause a change to the geometric shape of the cables.
 - 1. Limit to a 40% fill in new construction.
- C. J-hooks shall not be spaced farther than 1.5 meters (5 ft.) apart, with a recommendation that they be spaced at 1 meter (3 ft.) apart. Note: Construction may require distances to exceed the maximum and are considered an exception requiring approval of project manager or building engineer.
- D. J-hooks or better must be installed without exception.

2.2 UNACCEPTABLE INSTALLATIONS

- A. Free flight of cables
- B. Resting or attaching of cables on pipes, conduits, HVAC duct work, fire sprinkler systems, basket tray, basket tray supports or on the ceiling tiles/grid.

END OF SECTION

SECTION 270533

CONDUITS AND BACK BOXES FOR COMMUNICATIONS SYSTEMS

PART 1 - GENERAL

1.1 RELATED DOCUMENTS

- A. Division 26 – Electrical work

PART 2 - PRODUCTS

2.1 APPROVED PRODUCT

- A. Conduits and Back boxes shall meet the construction requirements of the NEC for the type of structure and space in which they are installed and will be of the diameter and size to provide adequate fill, bend radius and connector space. Refer to section 270528.

PART 3 - EXECUTION

3.1 CONDUIT SIZING

- A. Conduit size shall be based on the type of cable installed and the required fill ratio and bend radius associated with the type of cable specified.
 - 1. Minimum conduit size to back box for CAT6A F/UTP shall be 1-inch EMT.
- B. Conduit and installation shall be provided by Division 26.
- C. All conduit stubs shall be installed with plastic bushings appropriate for the size of conduit used.
- D. Conduits that stub to accessible ceiling shall be installed in the direction to provide the shortest path to the TDR, complete with pull string.

3.2 BACK BOX SIZING

- A. New work back boxes for CAT6A F/UTP shall be a minimum of trade size 4-11/16" x 4-11/16" x 3" (depth) plus a 5/8" plaster ring to allow for proper bend radius and connector termination/installation. Side knockouts shall be avoided.
- B. Back boxes for rework shall meet the same specification as for new work.
 - 1. If existing back boxes or back boxes that are smaller due to construction restrictions, then devices such as extension rings, bezels or faceplates shall be used to modify the back box to insure proper bend radius and connector termination/installation.
 - a. Verification and approval of the size change must have DCO Infrastructure Cabling and engineering approval.

3.3 BACK BOX COMPOSITION

- A. All back boxes for IT systems shall be UL/CSA listed and approved for the purpose.
 - 1. Non-metal back boxes shall not be used for any interior IT related device.

3.4 SPECIAL CONDITIONS – LEAD LINED WALLS FOR RADIATION CONTROL

- A. Refer to the complete IT Lead Lined Wall Procedure – Attachment Appendix 8

END OF SECTION

SECTION 270536

CABLE TRAY FOR COMMUNICATIONS SYSTEMS

PART 1 - GENERAL

1.1 RELATED DOCUMENTS

- A. This section shall be coordinated with Sections 270528, 270539, and 270543_46

1.2 COORDINATION

- A. Prior to beginning installation, a kick-off meeting to properly coordinate the tray installation and expectations should be held. It should be arranged by the General Contractor, and at a minimum include representatives of the following trades: FP&D, Electrical (Div 26), Structured cable, Nurse Call, paging, building automation and control, plumbing, HVAC, fire sprinkler, framing, and others as applicable. The Data Center Operations Infrastructure Cabling Team will lead the meeting.
- B. The wire basket tray routing shall be approved by the low voltage CI cable contractor (Div. 27 sub-contractor), and the Data Center Operations.
- C. Where adequate space is available a Triple tier J-Hook pathway shall parallel the basket trays for other services
 - 1. The triple tier J-Hooks shall be installed by the cable tray installer.
- D. Single J-Hooks as needed to extend beyond the triple tier, shall be installed by the trade that will be utilizing them.
- E. Cable tray shall be a high priority installation to allow adequate time for proper and complete cable installation prior to ceiling grid.

PART 2 - PRODUCTS

2.1 APPROVED PRODUCT

- A. The Cable Tray shall meet or exceed the below characteristics of construction and features:
 - 1. It shall be fully welded and available in a galvanized silver or powder coat black finish
 - 2. Have an optional construction using "elongated" shaped wires offering a more broad-based support for installed cables.
 - 3. Cable ladder shall be used in data rooms for horizontal management above the racks.
 - 4. Ladder shall match the manufacturer of the data racks or exact equal.
 - 5. Ladder shall be assembled with manufacturer approved parts and methods.
- B. APPROVED MANUFACTURES
 - 1. WBT – Wire Basket Tray (preferred)
 - 2. Siemon RouteIT™ Wire Mesh Cable Tray, or equal basket type tray
 - 3. Cabofil per owner's approval

2.2 PART NUMBERS (SUBMITTAL REQUIRED)

- A. Cable Tray
 - 1. Refer to plans for part numbers.

PART 3 - EXECUTION

3.1 PATHWAY INSTALLATION

- A. Supports
1. Installed per Manufacturer's Specifications and utilize components specific to the maintenance of proper access in and out of the cable tray using bend delimiters.
 2. Distance between supports shall not exceed 5 feet
 - a. Less distance between supports required if per manufacturer's instructions.
 - b. Minimum of one support required within 24" on each side of any junction point.
 3. Supports shall be of the trapeze design to provide maximum stability.
 - a. Each support shall attach to structure via its own hangers.
 - 1) All hanger supports shall be constructed of a rigid material such as all-thread.
 - 2) All hangers and supports shall be installed perpendicular and plumb to the tray. No angle supports shall be permitted unless augmented perpendicularly.
 - 3) Vibration and sway (seismic) damping required.
 - 4) Provide support across width of tray underneath, not via basket side wires.
 - 5) Building walls do not qualify as a support and shall not be used as a support.
 4. Supports shall be of sufficient strength to support at least 200% of the expected load
 5. Wall mounted angle brackets shall not be used as a load bearing support for cable tray.
- B. Complete system access
1. Cable tray shall have a dedicated free clearance zone surrounding it.
 - a. 12" clear space shall be provided on the side where natural feed will occur.
 - b. 6" clear space shall be provided on the side opposite the feed access.
 - c. 8" clear space above the top of tray minimum – recommended 12".
 - d. 3" clear space below the tray.
 2. Exception: other services may pass through the free clearance zone provided it is perpendicular to the tray direction and providing they do not exceed 6' in width or interfere with the access to pull wire in the tray.

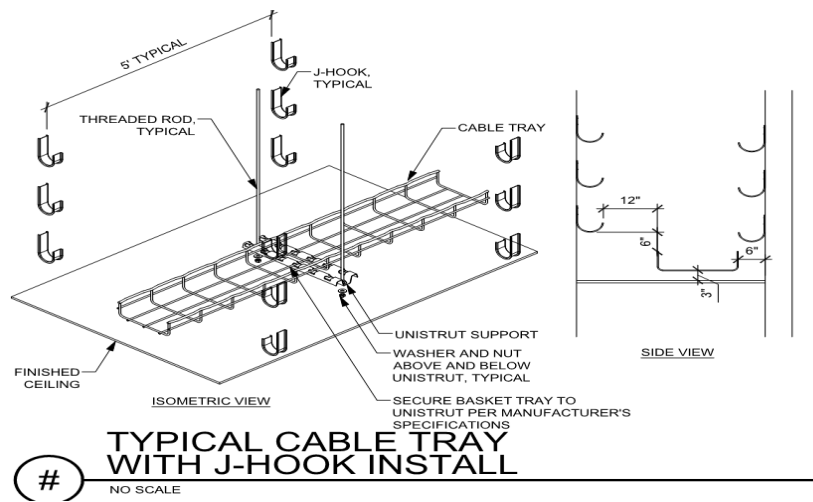

3.2 ROUTING OF BASKET TRAY

- A. Exact cable tray location shall be coordinated with other trades to ensure proper clearances and access. Prior to installation, final cable tray routing must be approved by the Owner's Data Center Operations/Infrastructure cabling team.
- B. Cable tray shall be installed in straight lines, either parallel or perpendicular to building lines
- C. Cable tray shall follow corridor paths
 - 1. Routing above rooms and other partitions shall be avoided
- D. Cable tray and flush penetrations shall be utilized over hard-lid areas as specified.
- E. Access panels shall be provided where needed to provide access to the cable tray on both sides of the wall in hard lid areas within 3' or less of the basket tray.

3.3 TRAY INTEGRITY

- A. Tray shall be installed as a complete, continuous system with no open spaces, cut outs, or missing segments. Bonding between sections shall be accomplished by the manufacturer's approved clamp or designated method.
- B. Tray shall be free from obstructions, other systems, trash or debris. Access to the tray shall be provided as outlined.
- C. There shall not to be any other trades infrastructure or equipment attached to or supported by the basket tray or basket tray support system.
- D. Tray must not be notched or cut-out to accommodate other trades. Repairs will not be accepted. Section replacement will be required at no cost to owner.
- E. As much tray material as possible shall be left uncut at turns, junctions, elevation changes, width changes, etc. Overlap shall be clamped to maximize strength and prevent pinch points.

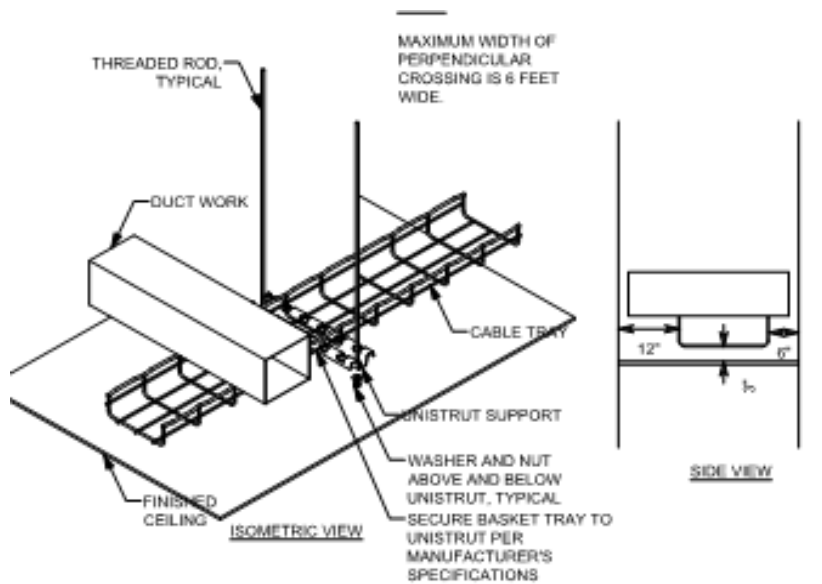

TYPICAL CABLE TRAY WITH PERPENDICULAR CROSSING

PART 4 - #

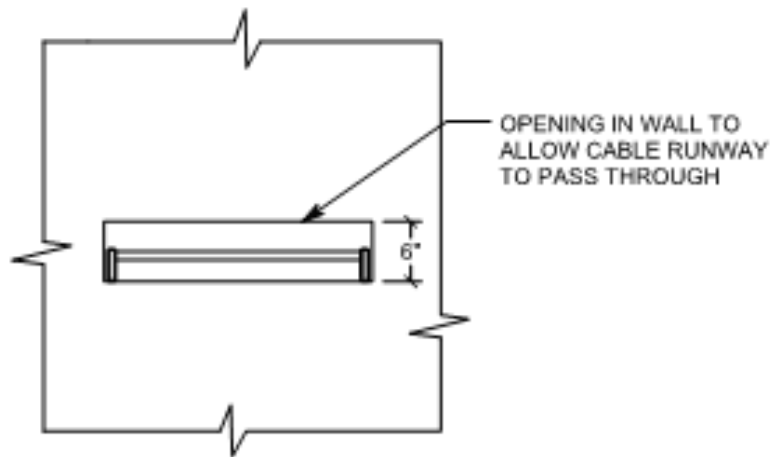

CABLE RUNWAY THROUGH WALL DETAIL

PART 5 - #

5.1 WALL OR OTHER PENETRATIONS (SUBMITTAL REQUIRED)

- A. Fire and smoke rated assemblies
 - 1. Penetrations shall comply with all fire and smoke prevention methods per codes and as outlined elsewhere in this document, including Section 270528 and Division 7.
- B. Approved penetration methods
 - 1. Preferred barrier penetration method shall be to run the tray continuous through the barrier, with closure provided by Firestop pillows.
 - a. Framing shall be boxed around openings to permit proper pillow insertion. Coordinate with framing contractor.
 - 2. Sleeves or conduits
 - a. EZ-Path or alternate penetrations must provide 150% of the designed cross-sectional area of the basket.
 - b. Conduit permitted only with written pre-bid permission or engineering notation on the drawings.
 - c. Each penetration sleeve or conduit shall be bonded on both sides of the penetrated barrier using UL and AHJ approved methods.
 - 3. All penetrations shall be positioned in-line with the cable tray to facilitate ease of pulling conductors and provide a straight-line path.
 - a. The bottom of the penetration device shall be flush with the bottom of the cable tray
 - b. Side-to-side penetrations must be completely within the cable tray space or directly above whenever possible.
 - 4. Approved penetration devices shall be a minimum size of 4"
 - a. Total penetration space at each location shall be sized for 20% growth and be equal to or greater than the cross-sectional area of the basket tray.
 - b. Approved devices where smaller penetrations are permitted shall be a minimum size of 1".
 - 5. Approved devices shall be approved by the local facility manager:
 - a. Fire rated STI EZ-Path

- b. Hilti self-sealing device
- c. Tray with enclosed wall and properly sized and installed pillows
- d. Conduit sleeves
 - 1) Conduit sleeves should only be used as a last resort upon approval from owner's Data Center Operations Infrastructure Cabling representative.

5.2 UTILIZATION

- A. Capacity
 - 1. Trays and penetration devices shall be properly sized
 - a. Provide a maximum calculated fill ratio of 40% to an inside depth not to exceed 3 inches (75 mm)
 - b. Provide capacity to allow for at least 20% future growth
- B. Systems served
 - 1. Cable trays, J-hooks, and penetrations shall be dedicated to a single system. Mixing of other systems with voice and data shall not be permitted in tray or J-hook paths.
 - 2. Exception: Different systems may share cable tray providing the following conditions are met:
 - a. Less than 40% overall fill is maintained, plus 20% additional space for growth
 - b. There is a minimum 3" separation between systems
 - c. There is a grounded physical divider between systems
- C. Restricted content in trays
 - 1. The wire basket tray shall only contain cables for the voice and data communications systems.
 - a. If there is sufficient space in the tray, and with approval from both the data network sub-contractor and the Data Center Operations, certain other IP services may share tray space. (i.e. camera, telemetry, similar).
 - b. Service loops must not reduce tray capacity.
 - c. Nurse call cabling shall be run in the J-Hook path. All nurse call installations must provide their own path or utilize the triple J-Hook system.
- D. Triple J-Hook path assignments
 - 1. The Lower tier of the triple J-Hook path is designated for Card Access and building automation and controls
 - 2. The Middle tier of the triple J-Hook path may alternately be utilized for Nurse Call, or other EMI producing systems.
 - 3. The Top tier of the triple J-Hook path is designated for satellite, DAS, or similar systems.
 - 4. When a triple J-hook pathway is not installed or available each system provider shall install their own j-hook pathway and wall penetrations.
 - 5. Service loop and slack shall not interfere with other pathways.

END OF SECTION

THIS PAGE LEFT BLANK INTENTIONALLY

SECTION 270543/46

UNDERGROUND DUCTS, UTILITY POLES, AND RACEWAYS FOR INTER- BUILDING/CAMPUS CABLE ROUTING

PART 1 - PRODUCTS

1.1 INTER-BUILDING/CAMPUS CABLE ROUTING

- A. The backbone subsystem shall include cable installed between buildings via approved underground, tunnel, direct -buried, aerial or any combination of these from the Campus Distributor/Main Cross-connect (CD/MC/TEC) to Building Distributor/Intermediate Cross-connect (BD/IC/TDR) in a multi-building campus.
 - 1. 4" Conduit is required
 - 2. (3) 1 ¼" inner ducts shall be installed in all 4" conduits going building to building.
 - 3. Armored Fiber is required.
 - 4. Microduct/microfiber is optional.
- B. Backbone pathways shall be installed or selected such that the minimum bend radius and pulling tension of backbone cables is kept within cable manufacturer specifications both during and after installation.
- C. In an underground system, adequate underground conduit space shall be available and accessible at each building. The conduits shall not exceed a fill ratio of 40%.
 - 1. All underground systems shall be designed to prevent water runoff from entering the building. All underground systems must be cleared of any moisture prior to installation of any cable type. These systems must be sealed at both ends when not in use and after cable installation to prevent moisture and rodent infiltration.

PART 2 - EXECUTION

2.1 INSTALLATION

- A. The backbone cables shall be installed in a hierarchical star topology, emanating from the Campus Distributor/Main Cross-connect to each satellite building, Building Distributor/Intermediate Cross-connect or Floor Distributor/Horizontal Cross-connect located in a telecommunication room. All Inter-building/Campus cables shall be installed to the applicable codes and regulations.
- B. Where redundant paths are required, they shall be separated by a minimum of 24".
 - 1. Separate innerducts are required for each leg of the redundant path.
 - 2. Separate physical routing for each path shall be utilized where possible.
- C. Optical fiber shall be run for all Inter-building/Campus backbone segments, and as a recommendation, at least one balanced twisted-pair cable should be run for each Inter-building backbone segment.
 - 1. Fibers will be Fusion Spliced in the telecommunications rooms using LC Pigtailed in wall mounted interconnect centers or rack mounted panels equipped with sufficient ports, slack storage space and splice trays if required to terminate and secure all fibers.
- D. ST connectors are no longer recommended in the TIA 568-C.3 standard but may be used in legacy installations.
- E. Over-voltage Circuit Protection shall be utilized for cabling which enters or exits a building shall comply with applicable codes and regulations.
- F. OSP (outside plant) cables shall transition to an ISP (inside plant) within 50 feet of changing environment, per national and local codes and regulations.

END OF SECTION

THIS PAGE LEFT BLANK INTENTIONALLY

SECTION 270553

IDENTIFICATION FOR LOW-VOLTAGE CABLES AND LABELING

PART 1 - GENERAL

1.1 NOT USED

PART 2 - PRODUCTS

2.1 LABELING

- A. Structured cabling shall be labeled in accordance with ANSI/TIA 606-B standards.
- B. A unique identifier shall be marked on each faceplate to identify it as connecting hardware.
- C. Each port in the faceplate shall be labeled with its identifier.
- D. A unique identifier shall be marked on each piece of connecting hardware to identify it as connecting hardware.
- E. Each port on the connecting hardware shall be labeled with its identifier.
- F. Cable Labeling
 - 1. Label System
 - a. Labels Identification (Labeling) System:
 - 1) Brady
 - 2) Dymo
 - 3) Hellerman-Tyton
 - 4) Panduit
 - 5) Acceptable alternate
 - a) Approval from Data Center Operations Infrastructure Cabling team member required prior to bid
 - 2. Cable Labels
 - a. Self-adhesive vinyl or vinyl-cloth wraparound tape markers, machine printed with alphanumeric cable designations. Plastic, self-adhesive labels are not acceptable.
 - b. Each end of the Horizontal cables shall be labeled with a mechanically generated label within 300mm (12 in) of the end of the cable jacket with the link identifier which shall be a unique configuration determined by owner. This also applies to the Backbone Cables.
 - 3. Flat-surface labels
 - a. Self-adhesive vinyl or vinyl-cloth labels, machine printed with alphanumeric cable designations
 - 4. Contractor shall:
 - a. Provide transparent plastic label holders, and 4 pair marked colored labels.
 - b. Install colored labels according to the type of field as per ANSI/TIA 606-B.1 color code designations.
- G. PALLETTE
 - 1. Use the owners color-code guidelines for voice, data, cross-connect, riser, and backbone fields. Otherwise, use the ANSI/TIA 606-B designation strip color-code guidelines for voice, data, cross-connect, riser, and backbone fields. Color designations for F/UTP cable:
 - a. Intermountain Healthcare Standard Wiring Palettes for Horizontal Cabling
 - b. Use

	Color
1) Data & IP Phones	Blue
2) Analog Phone	Blue

- | | | |
|-----|---|-------------|
| 3) | Security Card Readers | Grey/Yellow |
| 4) | IP Security Cameras | Blue |
| 5) | Fire Systems | Red |
| 6) | TV Coax | Black |
| 7) | Public Address/Telecom Patching in TEC only | White |
| 8) | Clinical Engineering – | Orange |
| | a) Monitoring, Bed Systems | Orange |
| | b) Nurse Call (5e) | Orange |
| | c) Real time patient data | Orange |
| 9) | Wireless | Yellow |
| 10) | Foreseer (Belden 1422) | Red |
- H. Outlet/Jack/Faceplate Icons/labeling will match the color of the cable attached to the back side of the outlet/jack.

PART 3 - EXECUTION

3.1 GENERAL IDENTIFICATION

- A. Installer shall label all cable, regardless of length.
- B. Identify system components, wiring, and cabling complying with TIA/EIA-606-B.1. Comply with requirements for identification specified in Division 26 Section "Identification for Electrical Systems."
- C. Color-code cross-connect fields. Apply colors to voice and data service backboards, connections, covers, and labels.
- D. Using cable management system software specified in Part 2, develop Cabling Administration Drawings for system identification, testing, and management. Use unique, alphanumeric designation for each cable and label cable, jacks, connectors, and terminals to which it connects with same designation. At completion, cable and asset management software shall reflect as-built conditions.
- E. Cable Schedule: Post in prominent location in each equipment room and wiring closet. List incoming and outgoing cables and their designations, origins, and destinations. Protect with rigid frame and clear plastic cover. Furnish an electronic copy of final comprehensive schedules for Project.
- F. Cabling Administration Drawings: Show building floor plans with cabling administration-point labeling. Identify labeling convention and show labels for telecommunications rooms, backbone pathways and cables, entrance pathways and cables, terminal hardware and positions, horizontal cables, work areas and workstation terminal positions, grounding buses and pathways, and equipment grounding conductors. Follow convention of TIA/EIA-606-B.1. Furnish electronic record of all drawings, in software and format selected by Owner

3.2 CONCEALED ENDS

- A. Jacks, connectors, terminations, and similar that are in concealed locations such as above grid ceilings, shall have additional labeling. The additional label shall be on the face of the grid in a visible location, immediately adjacent to the termination location.

3.3 CABLE AND WIRE IDENTIFICATION

- A. Label each cable visibly within 4 inches of each termination and tap, where it is accessible in a cabinet or junction or outlet box, and elsewhere as indicated.
- B. Each wire connected to building-mounted devices is not required to be numbered at device if color of wire is consistent with associated wire connected and numbered within panel or cabinet.
- C. Label each terminal strip and screw terminal in each cabinet, rack, or panel.
 - 1. Individually number wiring conductors connected to terminal strips and identify each cable or wiring group being extended from a panel or cabinet to a building

mounted device shall be identified with name and number of particular devices as shown.

2. Label each unit and field within distribution racks and frames.
- D. Labels shall be preprinted or computer-printed type with printing area and font color that contrasts with cable jacket color but still complies with requirements in TIA/EIA-606-B.1.

END OF SECTION

THIS PAGE LEFT BLANK INTENTIONALLY

SECTION 271100

EQUIPMENT ROOM FITTINGS

PART 1 - GENERAL

1.1 RELATED DOCUMENTS

- A. Requirements of the following Division 26 sections apply to this section
 - 1. Basic electrical requirements
 - 2. Basic electrical materials and methods
 - 3. Grounding, earthing, and bonding
- B. Standards
 - 1. Minimum equipment room specifications shall comply with the 2010 AIA Guidelines for Design and Construction of Healthcare Facilities.
 - 2. Minimum recommended room sizes are requirements, not suggestions.
 - 3. Enterprise IS Architecture (EISA) maintains several documents around standards. The primary standards list is the EISA Standards 2010 – Master List. Occasionally, there is a need to breakout specific standards for an area.

1.2 SUMMARY

- A. This Section specifically details the facilities design and operations standards to be utilized for Intermountain Health Care's Data Rooms (TEC) and data closets (TDR).

1.3 COMMON REQUIREMENTS

- A. Rack layout and mounting
 - 1. Standard room layouts are located on the plans.
- B. Rack and wall mounting locations
 - 1. Rack and wall space use is pre-designated at the design stage. Before mounting any equipment on a wall or in a rack, the location must be verified by the Div 27 sub-contractor and the Data Center Operations.

1.4 DEFINITIONS

- A. **Data Center** – Major computer/technology/network facilities providing a significant percentage of the data and application services for the enterprise.
- B. **Data Rooms – ((TEC) Technology Equipment Center)** – Purpose built buildings or rooms that provide communications point-of-presence along with some data and applications services for a local facility or region.
- C. **TSER (Telecommunications Service Entrance Room)** – Houses the point at which data and voice circuits and services enter the facility and outdoor cabling interfaces with the building infrastructure. Typically, the TSER will be located in the TEC.
- D. **Data Closets – ((TDR) Technology Distribution Room)** – Specific location within a facility that provides communication services for a specific area (floor, wing, office area) of that facility only. A secure, flexible, and easily managed location for the structured cabling systems, network electronics, clinical systems, nurse call systems, and other technology and communications equipment.

PART 2 - TECHNOLOGY ROOM SPECIFIC REQUIREMENTS

2.1 TECHNOLOGY EQUIPMENT CENTER (TEC)

- A. Each Hospital will have a dedicated TEC which will serve as the main communications point-of-presence along with data and application services for the local facility or region. Houses the core networking equipment, application servers and data storage devices

that serve the buildings on the campus. The Telecommunications Service Entrance Room (TSER) will be in the same room.

2.2 TEC IN HOSPITALS

- A. Physical Construction
 - 1. The TEC should be in an area easily accessed for delivery of equipment and high traffic without disturbing patient care.
 - 2. The size of the TEC will be based on the number of cabinets required to support the campus, plus 30% growth.
 - 3. Walls will be constructed from the floor to the deck and be completely sealed from surrounding spaces.
 - 4. A minimum 50% of open wall space will have ¾" fire rated plywood covering the walls.
 - 5. Fire rated plywood shall be painted with fire resistant paint, leaving the fire rating stamp un-painted.
 - 6. The TEC should not have a ceiling other than the deck.
 - 7. Static Dissipative Tile is required in the TEC.
 - 8. The door to the TEC shall be 8' tall and 4' wide to accommodate the cabinet height.
 - 9. The walls of the TEC should not have any windows installed.
- B. Layout
 - 1. Cabinets will be in a cold isle configuration.
 - 2. Containment will be installed, including removable ceiling panels and isle doors.
- C. Electrical
 - 1. The electrical distribution system will follow an A (BLUE) – B (RED) design.
 - 2. Each system A (BLUE) and B (RED) will be backed up by a dedicated UPS.
 - 3. Outlet type is L21-30
 - 4. All power is to be run in conduit.
 - 5. Lighting will be installed above each isle.
- D. Mechanical
 - 1. The mechanical system will be a precision cooling solution installed in an in row, N+1 configuration designed to maintain 72 degrees F at mid cabinet.
 - 2. The mechanical system will be redundant and concurrently maintainable including on the electrical supply.
 - 3. The system shall meet engineering specifications for the room at 110 degrees outside air at 4500 feet above sea level.
 - 4. Chilled water, DX (Air Cooled) and Glycol (30% polyethylene glycol to water) are all acceptable cooling strategies.
- E. Security
 - 1. Doors will be fitted with an auditable card reader.
- F. Fire System
 - 1. A pre-action dry pipe fire system will be installed
- G. Monitoring
 - 1. Eaton Forseeer system will be used to monitor all critical systems.
 - 2. Forseeer cables will be run to all UPSs, cooling units and TDRs.
 - 3. One Cat 6a F/UTP cable to each UPS.

2.3 TEC in Clinics and Office Buildings

- A. Clinics and Offices will have a room which will serve as a TEC and TDR. This room will be sized to accommodate the multifunction of the space.

2.4 TEC/TDR in Clinics

- A. Physical Construction
 - 1. TDRs should be in a central location off the main corridor away from patient areas.

2. TDRs should be stacked from floor to floor.
 3. TDR size will be at least 12' x 14'.
 4. Walls will be constructed from the floor to the deck and be completely sealed from surrounding spaces.
 5. A minimum 50% of open wall space will have ¾" fire rated plywood covering the walls.
 6. Fire rated plywood shall be painted with fire resistant paint, leaving the fire rating stamp un-painted.
 7. The TDR should not have a ceiling other than the deck.
 8. Flooring can be Static Dissipative Tile or Epoxy Paint.
 9. 3' wide door is required.
 10. When permissible, doors shall swing out of the room to provide maximum available space and rapid egress.
- B. Layout
1. Racks in a single row with the front being the cold isle.
 2. The front of the racks should face the door.
- C. Electrical
1. The electrical distribution system will follow an A (BLUE)-B (RED) design.
 2. System A(BLUE) will be backed up by a dedicated UPS.
 3. System B(RED) will be from a dedicated utility circuit.
 4. Outlet type is L6-30 and L5-20.
 5. All power is to be run in conduit.
 6. Lighting will be installed above each isle.
- D. Mechanical
1. TDRs will have redundant cooling
 - a. Primary cooling is from the facility cooling system via a dedicated source.
 - b. Secondary cooling is from a standalone split or ceiling mount source.
 - c. The secondary system will be fed from the facility generator equipment electrical source if available.
 - d. The Mechanical system will be designed to maintain 72 degrees F at mid rack.
 - e. The coordination scheme between primary and secondary cooling systems can be accomplished by setting the primary system to 72 degrees F and the secondary system to 75 degrees F.
- E. Security
1. Doors will be fitted with an auditable card reader.
- F. Fire System
1. TDRs will utilize the facility fire detection and suppression systems.
 2. Sprinkler heads should have a 200-degree fuse.
 3. Sprinklers should be protected from accidental activation.
- G. Monitoring
1. TDRs will be monitored using Eaton/Foreseer.
 2. Run 3 foreseer cables to each TDR.
 3. One Cat6a F/UTP cable to each UPS.

2.5 TEC/TDR in Offices

- A. Physical Construction
1. TDRs should be in a central location off a main corridor.
 2. TDRs should be stacked from floor to floor.
 3. TDR size will be at least 12' x 14'.
 4. Walls will be constructed from the floor to the deck and be completely sealed from surrounding spaces.
 5. A minimum 50% of open wall space will have ¾" fire rated plywood covering the walls.
 6. Fire rated plywood shall be painted with fire resistant paint, leaving the fire rating stamp un-painted.
 7. The TDR should not have a ceiling other than the deck.

8. Flooring can be Static Dissipative Tile or Epoxy Paint.
 9. 3' wide door is required.
 10. When permissible, doors shall swing out of the room to provide maximum available space and rapid egress.
- B. Layout
1. Racks in a single row with the front being the cold isle.
 2. The front of the racks should face the door.
- C. Electrical
1. The electrical distribution system will follow an A (BLUE)-B (RED) design.
 2. System A(BLUE) will be backed up by a dedicated UPS.
 3. System B(RED) will be from a dedicated utility circuit.
 4. Outlet type is L6-30 and L5-20.
 5. All power is to be run in conduit.
 6. Lighting will be installed above each row.
- D. Mechanical
1. TDRs will have redundant cooling system designed to maintain 72 degrees F at mid rack.
 - a. Primary cooling is from the facility cooling system via a dedicated source.
 - b. Secondary cooling is from a standalone split or ceiling mount source.
 - 1) The secondary system will be fed from the facility generator equipment electrical source if available.
 - c. The coordination scheme between primary and secondary cooling systems can be accomplished by setting the primary system to 72 degrees F and the secondary system to 75 degrees F.
 2. Doors will be fitted with an auditable card reader.
- E. Fire System
1. TDRs will utilize the facility fire detection and suppression systems.
 2. Sprinkler heads should have a 200-degree fuse.
 3. Sprinklers should be protected from accidental activation.
- F. Monitoring
1. TDRs will be monitored using Eaton/Foreseer.
 2. Run 3 foreseeer cables to each TDR.
 3. One Cat 6a F/UTP cable to each UPS.

2.6 TECHNOLOGY DISTRIBUTION ROOM (TDR)

- A. There shall be a minimum of one TDR on each floor of the facility. TDR's shall be provided throughout the facility as necessary to meet the 292' (90-meter) maximum cables distance. The TDR is located on each floor within a facility to house equipment and cabling, providing communication and technology services for a specific area of that facility. Based on the different needs of different facilities, the TDR's will be broken down into three categories. Hospital, Clinic and Office spaces.

2.7 TDR IN HOSPITALS

- A. Physical Construction
1. TDRs should be in a central location off a main corridor and away from patient areas.
 2. TDRs should be stacked from floor to floor.
 3. TDR size will be at least 14' x 16'.
 4. Walls will be constructed from the floor to the deck and be completely sealed from surrounding spaces.
 5. A minimum 50% of open wall space will have ¾" fire rated plywood covering the walls.
 6. Fire rated plywood shall be painted with fire resistant paint, leaving the fire rating stamp un-painted.
 7. The TDR should not have a ceiling other than the deck.
 8. Flooring can be Static Dissipative Tile or Epoxy Paint.

9. 3' wide door is required.
 10. When permissible, doors shall swing out of the room to provide maximum available space and rapid egress.
- B. Layout
1. Racks will be in a cold isle configuration.
 2. Two rows with the cold isle in the middle.
- C. Electrical
1. The electrical distribution system will follow an A (BLUE)-B (RED) design.
 2. Each system A(BLUE) and B(RED) will be backed up by a dedicated UPS.
 3. Outlet type is L6-30 and L5-20.
 4. All power is to be run in conduit.
 5. Lighting will be installed above each row.
- D. Mechanical
1. TDRs will have redundant cooling designed to maintain 72 degrees F at mid rack.
 - a. Primary cooling is from the facility cooling system via a dedicated source.
 - b. Secondary cooling is from a standalone split or ceiling mount source.
 - c. The secondary system will be fed from the facility generator equipment electrical source if available.
 - d. The coordination scheme between primary and secondary cooling systems can be accomplished by setting the primary system to 72 degrees F and the secondary system to 75 degrees F.
- E. Security
1. Doors will be fitted with an auditable card reader.
- F. Fire System
1. TDRs will utilize the facility fire detection and suppression systems.
 2. Sprinkler heads should have a 200-degree fuse.
 3. Sprinklers should be protected from accidental activation.
- G. Monitoring
1. TDRs will be monitored using Eaton/Foreseer.
 2. Run 3 foreseer cables to each TDR.
 3. One Cat 6a F/UTP cable to each UPS.

2.8 TDR in Clinics

- A. Physical Construction
1. TDRs should be in a central location off a main corridor and away from patient areas.
 2. TDRs should be stacked from floor to floor.
 3. TDR size will be at least 10' x 12'.
 4. Walls will be constructed from the floor to the deck and be completely sealed from surrounding spaces.
 5. A minimum 50% of open wall space will have ¾" fire rated plywood covering the walls.
 6. Fire rated plywood shall be painted with fire resistant paint, leaving the fire rating stamp un-painted.
 7. The TDR should not have a ceiling other than the deck.
 8. Flooring can be Static Dissipative Tile or Epoxy Paint.
 9. 3' wide door is required.
 10. When permissible, doors shall swing out of the room to provide maximum available space and rapid egress.
- B. Layout
1. Racks in a single row with the front being the cold isle.
 2. The front of the racks should face the door.
- C. Electrical
1. The electrical distribution system will follow an A (BLUE)-B (RED) design.
 2. System A(BLUE) will be backed up by a dedicated UPS.
 3. System B(RED) will be from a dedicated utility circuit.

4. Outlet type is L6-30 and L5-20.
 5. All power is to be run in conduit.
 6. Lighting will be installed above each isle.
- D. Mechanical
1. TDRs will have redundant cooling designed to maintain 72 degrees F at mid rack
 - a. Primary cooling is from the facility cooling system via a dedicated source.
 - b. Secondary cooling is from a standalone split or ceiling mount source.
 - c. The secondary system will be fed from the facility generator equipment electrical source if available.
 - d. The coordination scheme between primary and secondary cooling systems can be accomplished by setting the primary system to 72 degrees F and the secondary system to 75 degrees F.
- E. Security
1. Doors will be fitted with an auditable card reader.
- F. Fire System
1. TDRs will utilize the facility fire detection and suppression systems.
 2. Sprinkler heads should have a 200-degree fuse.
 3. Sprinklers should be protected from accidental activation.
- G. Monitoring
1. TDRs will be monitored using Eaton/Foreseer.
 2. Run 3 foreseer cables to each TDR.
 3. One Cat 6a F/UTP cable to each UPS.

2.9 TDR in Offices

- A. Physical Construction
1. TDRs should be in a central location off a main corridor.
 2. TDRs should be stacked from floor to floor.
 3. TDR size will be at least 10' x 12'.
 4. Walls will be constructed from the floor to the deck and be completely sealed from surrounding spaces.
 5. A minimum 50% of open wall space will have 3/4" fire rated plywood covering the walls.
 6. Fire rated plywood shall be painted with fire resistant paint, leaving the fire rating stamp un-painted.
 7. The TDR should not have a ceiling other than the deck.
 8. Flooring can be Static Dissipative Tile or Epoxy Paint.
 9. 3' wide door is required.
 10. When permissible, doors shall swing out of the room to provide maximum available space and rapid egress.
- B. Layout
1. Racks in a single row with the front being the cold isle.
 2. The front of the racks should face the door.
- C. Electrical
1. The electrical distribution system will follow an A (BLUE)-B (RED) design.
 2. System A(BLUE) will be backed up by a dedicated UPS.
 3. System B(RED) will be from a dedicated utility circuit.
 4. Outlet type is L6-30 and L5-20.
 5. All power is to be run in conduit.
 6. Lighting will be installed above each isle.
- D. Mechanical
1. TDRs will have redundant cooling designed to maintain 72 degrees F at mid rack.
 - a. Primary cooling is from the facility cooling system via a dedicated source.
 - b. Secondary cooling is from a standalone split or ceiling mount source.
 - c. The secondary system will be fed from the facility generator equipment electrical source if available.

- d. The coordination scheme between primary and secondary cooling systems can be accomplished by setting the primary system to 72 degrees F and the secondary system to 75 degrees F.
- E. Security
 - 1. Doors will be fitted with an auditable card reader.
- F. Fire System
 - 1. TDRs will utilize the facility fire detection and suppression systems.
 - 2. Sprinkler heads should have a 200-degree fuse.
 - 3. Sprinklers should be protected from accidental activation.
- G. Monitoring
 - 1. TDRs will be monitored using Eaton/Foreseer.
 - 2. Run 3 foreseer cables to each TDR.
 - 3. One Cat 6a F/UTP cable to each UPS.

PART 3 - EXECUTION

3.1 COMMON REQUIRED CHARACTERISTICS FOR TDR, TEC, & TSER

- A. SECURITY - COMMON
 - 1. Any visitor, vendor, or contractor requiring access to a Technology Room, who does not have appropriate approvals or clearances, must be escorted by a properly credentialed tech from the appropriate system.
 - 2. The main technology equipment shall be secured in a dedicated, locked Technology Room.
 - 3. Unused access jacks should be disconnected from the patch panels, and unused switch ports disabled.
 - 4. Technology Rooms shall be dedicated to the data and telecommunications functions.
 - 5. Access to the Technology Room shall be restricted to authorized service personnel and shall not be shared with building services that may interfere with the main networking interfaces, the networking equipment, the application servers, data storage devices, and telecommunications equipment systems.
 - 6. Technology Rooms shall not be used for building maintenance services, custodial services, or be used for general storage.
 - 7. Security cameras may be installed in each Technology Room upon owner's preference.
 - a. At entrances
 - b. At the end of each row of equipment racks
 - c. In electrical and mechanical rooms serving the Technology Room
 - d. Approved camera manufacturers: Axis and Bosch
 - 8. Access to a Technology Room shall be restricted and controlled by an auditable access control system. The access control system shall comply with the requirements of this document.
 - 9. All secure data areas must be secured by an auditable badge reader system.
 - a. Refer to plans or quotes for detailed information
 - b. Approved supplier: Intermountain Lock and Security Supply / 3106 S Main St / Salt Lake City, UT 84115 / 801-486-0079
 - c. Owner of security locks and badge readers: Intermountain Healthcare Data Center
 - d. For programming on the Medeco XT Electronic Keys contact: Intermountain Healthcare Data Center
- B. PHYSICAL ENVIRONMENT
 - 1. The Technology Room shall be in a dry area not subject to flooding and should be as close as possible to the electrical service room in order to reduce the length of the bonding conductor to electrical grounding system.
 - 2. The Technology Room shall be in an accessible, non-sterile area.

3. Access to the Technology Room shall be directly off a corridor and not through another space.
4. The Technology Room shall be located to avoid large ducts, beams, and other building elements that may interfere with proper cable routing and may limit future access.
5. Mechanical and electrical equipment or fixtures not directly and exclusively related to the support of the Technology Room shall not be installed in, pass through, or enter the Technology Room.
6. Technology rooms shall not be located on exterior walls.
7. Technology rooms shall not have windows or other exterior openings.

3.2 TECHNOLOGY DISTRIBUTION ROOM (TDR) / DATA CLOSET

A. ELECTRICAL ENVIRONMENT

1. Separation from sources of EMI shall be in accordance with ANSI/TIA/EIA-569-C and local codes.
2. Communication grounding/earthing and bonding shall be in accordance with applicable codes and regulations. It is recommended that the requirements of IEC/TR3 61000-5-2 - Ed. 1.0, ANSI-J-STD-607-C, or both be observed throughout the entire cabling system.
 - a. All racks, equipment frames, furniture, flooring, ductwork within the IT space shall be bonded to the Central Ground bar provided and installed by Division 26.
 - 1) No AC electrical equipment bonding will be done at the Central Ground Bar. AC electrical grounding and bonding will be done according to the NEC.
3. Some TDRs will require redundant power and data feeds. See plans and drawings.
4. Lighting in the TDRs should be a minimum of 500 lx (50-foot candles) at the lowest point of termination.
 - a. Light switch should be easily accessible when entering the room.
 - b. Lighting will be fed from the generator system or have fixtures with battery backup.
5. A minimum of two dedicated duplex or two dedicated simplex electrical outlets, each on a separate 120V 20A circuit, should be provided for equipment power. Additional convenience duplex outlets should be placed at 1.8 m (6 ft) intervals around the perimeter walls.
 - a. Only twist lock receptacles will be used for rack power points. Type L-6-30R for 208 volt and type Nema L-5-20R for 120 volt
6. All power is to originate from the facilities generator backup system with one system (A-B) originating from the critical system.
7. All circuits serving the TDR and the equipment within it shall be dedicated to serving the TDR.
8. TDRs shall be connected by a backbone of insulated, #6 (minimum) to 3/0 AWG stranded copper cable between all technology rooms. This cable shall be provided and installed by Division 26.

B. MECHANICAL ENVIRONMENT

1. Reliable cooling shall be provided.
 - a. Based on criticality tiering structure individual rooms may require redundant, concurrently maintainable cooling systems.
 - b. Tier structure level shall be determined from the design guide.
2. Heat load shall be calculated at 4KW per equipment rack
3. Temperature and humidity in the TDR shall be controlled to an operating range of 64 to 75 degrees F (18 to 24 degrees C) with 30 to 55 percent relative humidity.

C. EQUIPMENT

1. Each TDR shall be connected to the TEC (Technology Equipment Center) to provide a building-wide network and communications system.

2. All racks, cabinets, sections of cable tray, and metal components of the technology system that do not carry electrical current shall be grounded.

3.3 TECHNOLOGY EQUIPMENT CENTER (TEC) / DATA ROOM

A. ELECTRICAL ENVIRONMENT

1. The TDR and TEC electrical environments shall match with the following exceptions:
2. All circuits serving the TEC and the equipment within it shall be dedicated to serving the TEC.

B. MECHANICAL ENVIRONMENT

1. TEC and TSER have the same mechanical environment.
2. Reliable cooling shall be provided.
3. Heat load shall be calculated at 4KW per equipment rack
4. Temperature and humidity in the TEC shall be controlled to an operating range of 64 to 75 degrees F (18 to 24 degrees C) with 30 to 55 percent relative humidity.

C. EQUIPMENT

1. Each TEC shall be connected to the TSER (Telecommunications Service Entrance Room) to provide an enterprise-wide network and communications system.
2. All racks, cabinets, sections of cable tray, and metal components of the technology system that do not carry electrical current shall be grounded.

3.4 TELECOMMUNICATION SERVICE ENTRANCE ROOM (TSER) / D-MARC

A. PURPOSE

1. The TSER (Telecommunications Service Entrance Room) equipment subsystem shall consist of shared (common) electronic communications equipment in the TEC or the TSER required to interface this equipment and distribution hardware to the transmission media of enterprise Wide Area Network (WAN) infrastructure.
2. The TSER shall be equipped to contain telecommunications equipment, cable terminations, and associated cross-connects.
 - a. Note that the AIA/State guidelines specify that the minimum size for a TSER is 12' by 14'.
 - b. Doors shall swing out of the room to provide maximum available space and rapid egress.
 - 1) Exception: where prohibited by fire or safety code.
3. The TSER shall be dedicated to the telecommunications function.

B. MECHANICAL ENVIRONMENT

1. Reliable cooling and heating shall be provided.
2. Temperature and humidity in the TSER shall be controlled to an operating range of 64 to 75 degrees F (18 to 24 degrees C) with 30 to 55 percent relative humidity.

C. EQUIPMENT

1. The TSER (Telecommunications Service Entrance Room) shall be connected to the specified WAN equipment to provide connectivity to the enterprise-wide network and communications system.
2. All racks, cabinets, sections of cable tray, and metal components of the technology system that do not carry electrical current shall be grounded.

END OF SECTION

THIS PAGE LEFT BLANK INTENTIONALLY

SECTION 271116

CABINETS, RACKS, FRAMES, AND ENCLOSURES

PART 1 - GENERAL

1.1 RELATED DOCUMENTS

- A. Cabinets and racks specifications are in TIA569-C and in the ET pages of the plans.

PART 2 - PRODUCTS

2.1 APPROVED PRODUCT

A. OPEN RACKS

1. For rack-mounted installations in a telecommunications room the installer shall use a 19 inch by 3-inch-deep equipment rack.
 - a. Equipment Rack 19" X 8', 52 RU, Black – Chatsworth 55053-715
 - b. Equipment Rack 19" X 7', 45 RU, Black – Chatsworth 55053-703
 - c. Exception: Where other size cabinets are specified by design team at owner's direction

B. WIRE MANAGERS

1. Part Numbers
 - a. Vertical Wire Manager, Double Sided, Black 10" wide x 8' tall – Chatsworth 40096-715
 - b. Vertical Wire Manager, Double Sided, Black 10" wide x 7' tall – Chatsworth 40096-703
 - c. Horizontal Wire Manager, 4U – Panduit PEHF4
2. Typical Standard Layout
 - a. Layout is 10" vertical manager, then 19" rack, then 10" vertical manager, then 19" rack, then 10" vertical manager.
 - b. Where more than 2 racks are called for, maintain the pattern of 10" vertical wire management on the ends, and 10" vertical management between racks.

C. CABINETS

1. Standard Cabinet
 - a. 2-Sided Cabinet – Vertiv E4562121120001S
 - b. 1-Sided Cabinet – Vertiv E4562122120001S
2. Wall Mount Cabinet
 - a. Vertical Wall Mount Cabinet – Legrand VWMSD-4RU-42-B
 - b. Vertical Wall Mount Cabinet – Legrand VWMSD-8RU-42-B
 - c. Fixed Mounting Rail Kit – Legrand VWM-RR-4RU
 - d. Fixed Mounting Rail Kit – Legrand VWM-RR-8RU
 - e. Pivoting Mounting Rail Kit – Legrand VWM-PIV-4RU
 - f. Fan Kits with 115 VAC fans – Legrand VWMFK-115
 - g. Top Brush Grommet Kit – Legrand VWMBGK
 - h. Circular Knockout Grommet Kit – Legrand VWMGR-30

END OF SECTION

THIS PAGE LEFT BLANK INTENTIONALLY

SECTION 271119

TERMINATION BLOCKS AND PATCH PANELS

PART 1 - GENERAL

1.1 RELATED DOCUMENTS

- A. Requirements of the following Division 26 sections apply to this section
 - 1. Basic electrical requirements
 - 2. Basic electrical materials and methods
 - 3. Grounding, Earthing, and Bonding

PART 2 - PRODUCTS

2.1 APPROVED PRODUCT

- A. PATCH PANELS – COPPER
 - 1. 48 Port CAT 6A Shielded, 1RU Angled Patch Panel with Outlets – Siemon Z6AS-PA-48A
 - 2. 48 Port CAT 6A Shielded, 1RU Flat Patch Panel with Outlets – Siemon Z6AS-PNL-U48K
 - 3. 24 Port CAT 6A Shielded, 1RU Flat Patch Panel with Outlets – Siemon Z6AS-PNL-U24K
 - 4. 48 Port CAT 5e, 2RU Angled Patch Panel, 110 Style – Siemon HD5-48A
 - 5. 48 Port CAT 5e, 2RU Flat Patch Panel, 110 Style – Siemon HD5-48
 - 6. 24 Port CAT 5e, 1RU Angled Patch Panel, 110 Style – Siemon HD5-24A
 - 7. 24 Port CAT 5e, 1RU Flat Patch Panel, 110 Style – Siemon HD5-24
 - 8. 19" Angled Blank Filler Panel, 1U, Black – Siemon PNL-BLNKA-1
 - a. Provide blank fillers where appropriate.
 - 9. 19" Flat Blank Filler Panel, 1U, Black – Siemon PNL-BLNK-1
 - a. Provide blank fillers where appropriate.
- B. PATCH PANELS – FIBER
 - 1. Rack Mount Fiber Enclosure – Siemon RIC3-48E-01
 - 2. Wall Mount Fiber Enclosure – Siemon SWIC3G-AA-01
 - 3. Blank Adapter Plate, Black – Siemon RIC-F-BLANK-01
 - 4. 12F-LCUPC-SM-Loaded-Splice Cassette - Siemon – RSC12-LCUSMA-B1
- C. CABINET PATCH PANEL – FIBER
 - 1. Lightstack Surface Mount Module Enclosure – Siemon – LSE-01
 - 2. Lightstack Surface Mount Splice Enclosure – Siemon – LSS-01
 - 3. LightStack LC Adapter Plate – Siemon LS-LS12-01C-AQ

PART 3 - EXECUTION

3.1 INSTALLATION

- A. For angled patch panels, the terminations shall cross in the back to the opposite path of the patch panel to maximize available cable bend radius.
- B. See illustration below in this section:

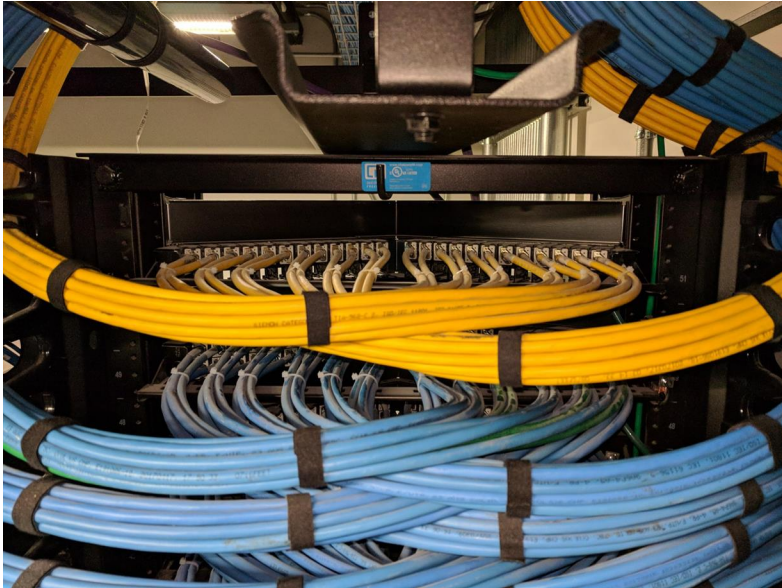

END OF SECTION

SECTION 271300

BACKBONE CABLING

PART 1 - GENERAL

1.1 RELATED DOCUMENTS

- A. Drawing and general provisions of the Contract, including General and Supplementary Conditions and Division 01 Specification Sections, apply to this section.
- B. Section 27 05 28 – Pathways for Communications Systems.

1.2 DEFINITIONS

- A. INTRA-BUILDING CABLING
 - 1. Cable that runs between telecommunications rooms (TRs) inside a building. Can be vertical or horizontal in physical orientation. It consists of the backbone transmission media between these locations and the associated connecting hardware terminating this media.
- B. INTER-BUILDING / CAMPUS CABLING
 - 1. Cable that runs between buildings in a campus environment. It is normally a first-level backbone cable beginning at the main cross-connect in the equipment room of the hub building and extending to the intermediate cross-connect in the equipment room of a satellite building. Campus Backbones require optical fiber cable to be installed to support high speed data applications.
 - 2. Customer owned outside plant (OSP) cabling.

PART 2 - PRODUCTS

2.1 PERMITTED BACKBONE MEDIA

- A. Cables allowed for use in the backbone include:
 - 1. CAT 6A F/UTP Riser, Blue, Data – Siemon 9A6R4-A5-06-R1A
 - 2. CAT 6A F/UTP Plenum, Blue, Data – Siemon 9A6P4-A5-06-R1A
 - 3. 50 Pair Category 3 Riser Cable Gray – General Cable 2133161 or equal
 - 4. Fiber Optic Cable, Single-mode, 24 Strand, Armored Indoor/Outdoor Cable, Black – Siemon 9BG8P024L-E201A
 - 5. Fiber Optic Cable, Single-mode, 24 Strand, Armored, Riser Cable, Yellow – Siemon 9BC8P024L-205A
 - 6. Fiber Optic cable, Multi-mode, OM4, 12 Strand, Armored, Riser Cable, Aqua – Siemon 9BC5P012G-T512A (Data Centers must be OM4 or better)
- B. The cable shall support voice, data and imaging applications. The bending radius and pulling strength requirements of all backbone cables shall be observed during handling and installation.
- C. Multi-pair twisted pair cable is intended to support analog voice applications and shall be tested for continuity only.
- D. In addition to meeting the applicable performance specifications, all copper and optical fiber cable shall be appropriate for the environment in which it is installed.

2.2 MEDIA PRODUCTS

- A. COPPER

1. The total channel length between the Campus Distributor/Main Cross-connect and to any floor Distributor/Horizontal Cross-connect shall not exceed the following length limits for copper cabling:
 - a. 2,000 m (6,560 ft) for balanced twisted pair for PBX/Class A (100 kHz) applications.
 - b. 200 m (656 ft) for balanced twisted pair for Class B (\leq 1 MHz) applications.
 - c. 100 m (328 ft) for balanced twisted-pair categories 6, 6A & 7 (per Backbone segment when providing a two-level Backbone).
- B. MULTIMODE OPTICAL FIBER
 1. See Siemon website for supportable fiber distances
 - a. Laser qualified 50/125 μ m multimode fiber optical fiber cables shall be in compliance with the following standards ISO/IEC 11801:2002 OM3, ANSI/TIA-568-C.3, ANSI/TIA-568-C.1 and Telcordia GR-409-CORE as well as the guaranteed application distances, attenuation, bandwidth, and group index of refraction requirements.
 - b. Specifications:
 - 1) Shall support 10GBASE-SX for all horizontal workstations, risers and short length backbone (<300 m) locations.
 - 2) Constructed for overfilled launch (OFL) and restricted mode launch (RML) bandwidth to ensure compatibility with both LED and laser light sources.
 - 3) Have an Aqua Outer Jacket and be available in cable ratings including OFNR and OFNP.
- C. SINGLE MODE OPTICAL FIBER
 1. See Siemon website for supportable fiber distances
 2. Single-mode optical fiber cable shall be used for 1st and 2nd Level Backbone applications only.
 3. All fiber is to fusion spliced terminations.

PART 3 - EXECUTION

3.1 TOPOLOGY

- A. The Backbone cabling shall use a conventional hierarchal star topology.
 1. There shall be no more than two (2) levels of cross-connects between the campus distributor/main cross –connect (CD/MC) and any given floor distributor/horizontal cross-connect (FD/HC).
 2. From the FD/HC no more than one cross-connect shall be passed through to reach the CD/MC.
- B. Splicing of UTP, F/UTP and S/FTP copper cables is not permitted.

3.2 TYPICAL TDR BACKBONE

- A. A typical TDR backbone for a hospital campus shall consist of:
 1. Redundant (2 ea.) 24 strand single-mode fiber each routed in a separate path.
 2. One 50 pair copper feed line.

END OF SECTION

SECTION 271500

HORIZONTAL CABLING

PART 1 - GENERAL

1.1 RELATED DOCUMENTS

- A. Drawings and general provisions of the Contract, including General and Supplementary Conditions and Division 01 Specification Sections, apply to this section.
- B. Section 27 05 28 - Pathways for Communications Systems

1.2 SUMMARY

- A. This section includes requirements and guidelines for the installation of F/UTP, ScTP, and Fiber horizontal cabling.
 - 1. Horizontal cable and its connecting hardware provide the means of transporting signal between the telecommunications outlet/connector and the horizontal cross-connect located in the communications termination room. This cabling and its connecting hardware are called "permanent link," a term that is used in the testing protocols.

PART 2 - EXECUTION

2.1 HORIZONTAL CABLE

- A. Quantity
 - 1. Two horizontal cables shall be routed to each work area. Cable connected to information outlets shall be CAT6A F/UTP, 4-pair, 100Ω balanced twisted-pair.
 - a. A work area is approximately 100 sq. ft. and includes the components that extend from the telecommunications outlet/connectors to the station equipment.
 - b. Two (2) standard cables shall be run to each wireless access point location per current best practice.
 - c. One (1) standard horizontal cable may be run to the following locations:
 - 1) Each building control system enclosure as directed by the building controls vendor.
 - 2) Each IP Video Surveillance Camera at each of the designated locations.
 - 3) Each wall phone.
 - 4) Each wall monitor/display.
 - 2. For voice or data applications, 4-pair balanced twisted-pair or fiber optic cables shall be run using a star topology from the telecommunications room serving that floor to every individual information outlet. The customer prior to installation of the cabling shall approve all cable routes.
 - 3. Installation interfaces shall be T568B wiring standards.
- B. Maximum Length
 - 1. All horizontal cables, regardless of media type, shall not exceed 90 m (295 ft.) from the telecommunications outlets in the work area to the Floor Distributor/Horizontal Cross connect (FD/HC) located in the Telecommunication Room.
 - 2. The combined length of jumpers, patch cords inclusive of equipment cables in the Floor Distributor/Horizontal Cross-connect shall not exceed 5m (16 ft.).
 - 3. The maximum length of Work Area equipment cables shall be 5m (16 ft.) if a

MuTOA (Multiple User Telecommunication Outlet) environment exists, then the

- maximum equipment cable shall not exceed 22m (72 ft.) (Lake Park Facility)
5. Terminate all conductors; no cable shall contain un-terminated elements. Make terminations only at indicated outlets, terminals, cross-connects, and patch panels.
- C. Minimum Length
1. It is recommended that a minimum horizontal cable distance of 15m (49 ft.) shall be maintained between the telecommunications room and the work area. This will provide adequate Insertion Loss/Attenuation for applications over 1 Gig.
 2. For installations with consolidation points, a minimum horizontal cable distance of 15m (49 ft.) shall be maintained between the telecommunications room and consolidation point, and 5m (16 ft.) between the consolidation point and the work area. This will provide adequate Insertion Loss/Attenuation for applications over 1 Gig.
- D. Splice Free
1. Each run of balanced twisted-pair cable between Floor Distributor/Horizontal Cross-connect in the telecommunication room and the information outlet at the Work Area shall not contain splices.
 2. Bridged taps and splices shall not be installed in the horizontal cabling
- E. Protection
1. Horizontal distribution cables shall not be run in under slab raceways that are damp or wet locations unless suitably rated for the environment.
 - a. Under slab conduits that are outside of the building are considered wet locations.
- F. Slack -Service Loop – Routing
1. In the work area, a minimum of 1m (3 ft) should be left for balanced twisted-pair cables and fiber cables.
 2. In telecommunications rooms a minimum of 3m (10 ft) of slack should be left for all cable types. This slack must be neatly managed on trays or other support types

2.2 SEPARATION

- A. Separation from EMI sources
1. Installation shall comply with BICSI TDMM and TIA/EIA-569-B for separating unshielded copper voice and data communication cable from potential EMI sources, including electrical power lines and equipment.
 2. Separation between open communications cables or cables in nonmetallic raceways and unshielded power conductors and EMI Source shall be as follows:
 - a. EMI Source Rating Less Than 2 kVA: A minimum clearance of 5 inches.
 - b. EMI Source Rating between 2 and 5 kVA: A minimum clearance of 12 inches.
 - c. EMI Source Rating More Than 5 kVA: A minimum clearance of 24 inches.
 3. Separation between communications cables in grounded metallic raceways and unshielded power lines or EMI Source shall be as follows:
 - a. EMI Source Rating Less Than 2 kVA: A minimum clearance of 2-1/2 inches.
 - b. EMI Source Rating between 2 and 5 kVA: A minimum clearance of 6 inches.
 - c. EMI Source Rating More Than 5 kVA: A minimum clearance of 12 inches.
 4. Separation between communications cables in grounded metallic raceways and power lines and EMI Source located in grounded metallic conduits or enclosures shall be as follows:
 - a. EMI Source Rating Less Than 2 kVA: A minimum clearance of 2 inches.
 - b. EMI Source Rating between 2 and 5 kVA: A minimum clearance of 3 inches.
 - c. EMI Source Rating More Than 5 kVA: A minimum clearance of 6 inches.
 5. Separation between Communications Cables and Electrical Motors and

- Transformers, 5 kVA or 1 HP and Larger: A minimum clearance of 48 inches.
6. Separation between Communications Cables and Fluorescent Fixtures: A minimum clearance of 5 inches
- B. Other Clearances
1. Horizontal pathways used for telecommunications cabling shall be dedicated for telecommunications use and not shared by other building services.
 2. In a false ceiling environment, a minimum of 75 mm (3 in) shall be observed between the cable supports and the false ceiling.

2.3 PATHWAY

- A. Cable Tie Wraps
1. Cable Tie Wraps are not permitted as a pathway device or support.
 2. Tie Wraps shall only be used to provide strain relief at termination points.
 3. Tie wraps shall not be over tightened to the point of deforming or crimping the cable sheath.
- B. Constraints
1. Horizontal cables shall be installed in "dry" locations that provide protection from moisture levels above the intended operating range of inside plant (ISP) cables.
 - a. If cabling is intentionally or unintentionally exposed to water or otherwise coated with or exposed to direct contact with solvents, paints, adhesives, sealants or other third-party materials, Siemon will not warranty the cabling product or if after the warranty has been issued, it would become void. Therefore, any cabling that has been exposed as listed above, must be removed and replaced.
 2. Horizontal pathways shall be installed or selected such that the minimum bend radius of horizontal cables is kept within manufacturer specifications both during and after installation.
 3. A minimum of a 1" diameter conduit is recommended for new construction. Existing conduits will require the reduction of the number of cables placed in the conduit to meet the required fill ratio.
 - a. The Contractor shall observe the bending radius and pulling strength requirements of the 4-pair balanced twisted-pair and fiber optic cable during handling and installation.
 - 1) 4-Pair UTP, F/UTP, S/FTP bend radius = 4 times outside diameter of cable under no-load conditions. 8 times the outside diameter under load (pulling 110 N/25 lbf.) conditions.
 - 2) Multi-pair or Hybrid cable bend radius = 10 times the outside diameter under all conditions.
 - 3) 2-Fiber and 4 Fiber cables bend radius = 25mm (1 in.) under no-load conditions. 50mm (2 in.) under load (pulling 222 N 50 lbf)
 4. Cable shall not be run through structural members or in contact with pipes, ducts, or other potentially damaging items.
 5. Cable that passes through non-Intermountain Healthcare spaces must be installed in conduit.
 6. Horizontal cabling shall contain no more than one transition point or consolidation point between the horizontal cross-connect and the telecommunications outlet/connector.
 7. Do not install bruised, kinked, scored, deformed, abraded cable or otherwise damaged cable. Do not splice cable between termination, tap, or junction points. Remove and discard cable if damaged during installation and replace it with new cable.
 8. During Cold-Weather Installation, bring cable to room temperature before de-reeling. Heat lamps shall not be used for heating.
- C. Capacity
1. The number of horizontal cables placed in a cable support or pathway shall be limited to the number of cables that will not alter the geometric shape of the cables.

2. Maximum pathway (cable tray/basket tray/wireway) capacity shall not exceed a calculated fill ratio of 50% to a maximum of 75 mm (3 in) inside depth.
3. Maximum conduit pathway capacity shall not exceed a 40% fill. However, perimeter and furniture fill are limited to 60% fill for move and changes. A 40% fill ratio is the maximum fill for CAT6A F/UTP cables.
4. All unused cables shall be removed
 - a. Or labeled at both ends designating future purpose and locations of each end.

END OF SECTION

SECTION 271513

COPPER CABLE

PART 1 - GENERAL

1.1 RELATED DOCUMENTS

- A. Drawings and general provisions of the Contract, including General and Supplementary Conditions and Division 01 Specification Sections, apply to this Section.

1.2 PALLETTE

- A. Color palette shall be in accordance with Section 27 05 53

1.3 SUMMARY

- A. This Section covers approved F/UTP cable types
- B. Systems shall be CAT6A F/UTP unless a written deviation has been approved.
- C. CAT6A UTP and CAT6A F/UTP shall not be mixed on the same campus.
- D. This cable shall be used for both voice and data applications and shall be plenum rated where required by code

PART 2 - PRODUCT

2.1 APPROVED PRODUCT

- A. TYPE 6A F/UTP (foil over unshielded twisted pair) - Siemon
 - 1. CAT 6A F/UTP Riser, (CMR) – Siemon 9A6R4-A5-(XX)-R1A
 - 2. CAT 6A F/UTP Plenum, (CMP) – Siemon 9A6P4-A5-(XX)-R1A
 - a. (XX) = Color – 06, Blue – 05, Yellow – 09, Orange

END OF SECTION

THIS PAGE LEFT BLANK INTENTIONALLY

SECTION 271543

FACEPLATES AND CONNECTORS

PART 1 - GENERAL

1.1 RELATED DOCUMENTS

- A. Drawings and general provisions of the Contract, including General and Supplementary Conditions and Division 01 Specification Sections, apply to this Section.

1.2 DEFINITION

- A. Work-Area Cabling
 - 1. The work area is comprised of work area outlet/connectors, faceplates, outlet boxes and equipment cords. It acts as the interface to the horizontal cabling from the horizontal cross-connect (HC) to telephone, network equipment, wireless access points (WAP) and OIP devices.

PART 2 - PRODUCT

2.1 OUTLETS

- A. Category 6A Jack – Siemon Z6A-S(XX)
 - 1. Use (XX) to specify color.
 - 2. Universal design allows the same outlet to be mounted in a flat or angled orientation.
- B. Category 6A Z-Plug WO Latch Protector – Siemon ZP1-6AS-(00)S
- C. Voice Outlet, Single Gang Faceplate, White W/Wall Hung Phone W/6A Insert – Siemon MX-WP-Z6AS-SS

2.2 FACEPLATES/BOXES

- A. 10G Single Gang Faceplate, White, 4 Position – Siemon 10GMX-FP-04-02
- B. MAX Single Gang Faceplate, White – Siemon MX-FP-S-(XX)-02
 - 1. USE (XX) to specify the number of ports.
- C. MAX Single Gang Faceplate, Stainless Steel, 4 Position, with Label Holder – Siemon MX-FP-S-04-SS-L
 - 1. To be used in the Operation Rooms
- D. Surface Mount Box, White, 2 Position – Siemon MX-SMZ2-02
- E. Furniture Faceplate, Black – Siemon MX-UMA-01
- F. Conference Room Table Inserts should include and HDMI port.

PART 3 - EXECUTION

3.1 WORK AREA TERMINATION

- A. All balanced twisted-pair cables wired to the telecommunications outlet/connector, shall have 4-pairs terminated in eight-position modular outlets in the work area. All pairs shall be terminated.
- B. Outlet/connector back boxes shall be a minimum 4-11/16 square box (4-11/16" x 4-11/16" x 3") with a minimum single gang 5/8" mud ring for new construction to accommodate the CAT6A connectors.
- C. Existing back boxes will require a faceplate stand-off and/or a faceplate that can accommodate a bezel to extend the CAT6A jack out to allow the installation of the CAT6A connectors.
- D. All outlets need to be installed in the angled position.

END OF SECTION

THIS PAGE LEFT BLANK INTENTIONALLY

SECTION 271619

PATCH CABLES

PART 1 - GENERAL

1.1 SUMMARY

- A. This section is issued as a guide for patch cable installations in the Data Center, wiring closets (TDR) and user areas where patch cables are required for connectivity to IP and TDM phones, and IP data connectivity needs for Intermountain Healthcare. All patch cables will support voice, data, and imaging applications within the Intermountain Healthcare Enterprise.

PART 2 - PRODUCTS

2.1 APPROVED PRODUCT

- A. Patch Cable, CAT 6A Shielded - Siemon SP6A-S (XX)-(XX)
 - 1. Use 1st (xx) to specify length. Use 2nd (xx) for color.
- B. Patch Cable, CAT 5e, Orange – Siemon MC5-(XX)-0909
 - 1. Use (xx) to specify length. For use with NURSE CALL only.
- C. Patch Cable, CAT 5e, White – Siemon MC5-(XX)-0202
 - 1. Use (xx) to specify length.
 - 2. For use in the TEC for the Copper Backbone Patch only.
- D. Patch Cable, Fiber, Singlemode Duplex W/LC Connectors, Yellow – Siemon FJ2-LCULCUL-(xx)
 - 1. Use (xx) to specify length.
- E. Patch Cable, Fiber, Multimode Duplex W/LC Connectors, Aqua – Siemon FJ2-LCLC5V-(xx)AQ
 - 1. Use (xx) to specify length. For use in the Data Center.

PART 3 - EXECUTION

3.1 PALLETTE

- A. Patch Cable Color Codes
 - 1. The Intermountain Healthcare Enterprise standard for patch cable color is in Section 27 05 53.
 - 2. The patch cable color shall match the feed cable color to identify the service provided.
- B. Contractor furnished
 - 1. All patch cables for the TEC, TDR's shall be included in the low voltage contract and will be required to match or exceed the existing level of the installed structured cabling system.
 - 2. All patch cables for the user areas shall be Owner furnished and will be required to match or exceed the existing level of the installed structured cabling system.
 - 3. All patch cables shall be Owner installed.
 - 4. The quantity of patch cables to be provided by the low voltage contractor shall be specified in the plans.
 - a. 50% 5ft – 30% 7ft – 15% 10ft – 5% 15ft

END OF SECTION

SECTION 27 52 23
NURSE CALL/CODE BLUE SYSTEMS

PART 1 - GENERAL

1.1 RELATED DOCUMENTS

- A. Drawings and general provisions of the Contract, including General and Supplementary Conditions and Division 01 Specification Sections, apply to this Section.
- B. Specification Section 27 00 00 "Intermountain Healthcare Structured Cabling Standards".

1.2 SUMMARY

- A. Section includes raceways, back boxes and cabling for a Hill-Rom Navicare Nurse Call (NNC) system.
- B. All active components and software to be provided, installed and programmed by Hill-Rom Vendor under contract with the owner.

PART 2 - PRODUCTS

2.1 NURSE-CALL SYSTEM:

- A. Nurse-Call System: Hill-Rom Navicare Nurse Call (NNC) System. All electronic components

2.2 CONDUCTORS AND CABLES

- A. Data Cable and Hardware: Category 5e, Orange, UTP and UTP hardware. Comply with requirements in Section 270000.
- B. Power Conductors and Cables: Copper, solid, No. 20 AWG. Comply with requirements in Section 26 05 19 "Low-Voltage Electrical Power Conductors and Cables."
- C. Grounding Conductors and Cables: Copper, stranded, No. 16 AWG. Comply with requirements in Section 26 05 19 "Low-Voltage Electrical Power Conductors and Cables."

PART 3 - EXECUTION

3.1 INSTALLATION

- A. Wiring Method:
 - 1. Install cables in raceways and J-Hooks except within consoles, cabinets, desks, and counters
 - a. Conceal raceway and cables except in unfinished spaces.
 - 2. Conduit and Boxes: Comply with requirements in Section 26 05 33 "Raceway and Boxes for Electrical Systems." Flexible metal conduit shall not be used.
 - a. Outlet boxes shall be no smaller than 2 inches (50 mm) wide, 3 inches (75 mm) high, and 2-1/2 inches (64 mm) deep.
 - b. Coordinate each outlet box type with Hill-Rom.
- B. Install cables without damaging conductors, shield, or jacket.
- C. Do not bend cables, while handling or installing, to radii smaller than as recommended by manufacturer.
- D. Pull cables without exceeding cable manufacturer's recommended pulling tensions.
 - 1. Pull cables simultaneously if more than one is being installed in same raceway.
 - 2. Use pulling compound or lubricant if necessary. Use compounds that will not damage conductor or insulation.
 - 3. Use pulling means, including fish tape, cable, rope, and basket-weave wire or cable grips, that will not damage media or raceway.
- E. Install exposed raceways and cables parallel and perpendicular to surfaces or exposed structural members, and follow surface contours. Secure and support cables by straps, staples, or similar fittings designed and installed so as not to damage cables. Secure cable at intervals not exceeding 30 inches (760 mm) and not more than 6 inches (150 mm) from cabinets, boxes, or fittings.
- F. Wiring within Enclosures: Bundle, lace, and train conductors to terminal points with no excess and without exceeding manufacturer's limitations on bending radii. Provide and use lacing bars and distribution spools.
- G. Separation of Wires: Separate speaker/microphone, line-level, speaker-level, and power-wiring runs. Run in separate raceways or, if exposed or in same enclosure, provide 12-inch (300-mm) minimum separation between conductors to speaker/microphones and adjacent parallel power and telephone wiring. Provide separation as recommended by equipment manufacturer for other conductors.
- H. Splices, Taps, and Terminations: Make splices, taps, and terminations on numbered terminal strips in junction, pull, and outlet boxes; terminal cabinets; and equipment enclosures. Install terminal cabinets where there are splices, taps, or terminations for eight or more conductors.
- I. Impedance and Level Matching: Carefully match input and output impedances and signal levels at signal interfaces. Provide matching networks if required.

- J. Identification of Conductors and Cables: Comply with requirements in Section 271500 "Communications Horizontal Cabling" for cable administration, cable schedule, and cable and wire identification.
- K. Equipment Identification:
 - 1. Comply with requirements in Section 260553 "Identification for Electrical Systems" for equipment labels and signs and labeling installation requirements.
 - 2. Label stations, controls, and indications using approved consistent nomenclature.

3.2 EXISTING SYSTEMS

- A. Examine existing systems for proper operation, compatibility with new equipment, and deficiencies. If discrepancies or impairments to successful connection and operation of interconnected equipment are found, report them and do not proceed with installation until directed. Schedule existing systems' examination so there is reasonable time to resolve problems without delaying construction.

3.3 GROUNDING

- A. Ground cable shields and equipment to eliminate shock hazard and to minimize ground loops, common-mode returns, noise pickup, cross talk, and other signal impairments.
- B. Signal Ground Terminal: Locate at main equipment cabinet. Isolate from power system and equipment grounding except at connection to main building ground bus.
- C. Grounding Provisions: Comply with requirements in Section 270526 "Grounding and Bonding for Communications Systems."

3.4 FIELD QUALITY CONTROL

- A. Manufacturer's Field Service: Engage a factory-authorized service representative to inspect, test, and adjust components, assemblies, and equipment installations, including connections.
- B. Perform tests and inspections.
 - 1. Manufacturer's Field Service: Engage a factory-authorized service representative to inspect components, assemblies, and equipment installations, including connections, and to assist in testing.

END OF SECTION

THIS PAGE LEFT BLANK INTENTIONALLY

SECTION 275319

INTERNAL CELLULAR, PAGING AND ANTENNA SYSTEMS

PART 1 - GENERAL

1.1 RELATED DOCUMENTS

- A. Drawings and general provisions of Contract, including General and Supplementary Conditions and Division 1 Specification Sections, apply to this Section.
- B. Requirements of the following Division 26 Sections apply to this Section:
 - 1. Basic Electrical Requirements.
 - 2. Basic Electrical Materials and Methods.

1.2 SUMMARY

- A. The DAS system is provided and installed as an Owner-provided, Owner installed (OFOI) system by a 3rd-party vendor, contracted and managed by Intermountain CTIS/Telecom Team.
- B. A/E to coordinate DAS requirements with the Owner's vendor to incorporate necessary infrastructure on their drawings to support a fully functional DAS system.

PART 2 - EXECUTION

2.1 INSTALLATION

- A. DAS contractor is to install their equipment located in the TDRs in the assigned rack location as noted in the ET Rack Elevation Drawings.
- B. DAS contractor is to install any wall mounted equipment in the TDRs in the assigned location as noted in the ET TDR Room Elevation drawings.
- C. Specific power requirements will need to be provided in the design phase of the project by the CTIS/Telecom team.
- D. Cable installation will follow Division 27 installation specifications.

END OF SECTION

SECTION 276001

APPENDIX 01 – DEVIATION REQUEST PROCESS

PART 1 - GENERAL

1.1 DEFINITIONS

- A. Cable Plant Deviation
 - 1. A business need to not fully comply with the requirements of the “Division 27 – Communications and Structured Cabling Specification document”
- B. Cable Plant Deviation Request form.
 - 1. The document is available from the Facilities Planning team, the Data Center Ops team, or the Infrastructure Cabling team.
 - 2. Usage:
 - a. The deviation request form shall be used if there is a business need to not comply with the requirements of the “Division 27 – Communications and Structured Cabling Specification document”
 - b. The deviation request form should also be used to propose a change to that document. Always verify that you are using the current version of the Standard before requesting a modification.

PART 2 - PROCESS

2.1 STANDARDS MODIFICATION

- A. Check the box and explain why the standard should be modified.

2.2 ALTERNATE PRODUCT

- A. The deviation form must be completed, submitted through channels, and approved prior to any deviation from the specifications. This includes issuing change orders.

2.3 AUTHORIZED SIGNATURES

- A. Both the Standards Holder and the DCO Manager signatures are required for a deviation to be valid.

2.4 DEVIATION REVIEW PROCESS STEPS

- A. First be sure that there is an actual need. Then be certain that your manager, supervisor, or project manager agrees with the requested deviation. Be sure to state this or obtain their signature on the deviation form. By doing so you are confirming that your supervisor or project manager has approved.
- B. The requestor will then complete sections 1, 2, and 3 of the deviation form.
 - 1. The requestor should then digitally sign in the designated location at the end of Section 3. Do not write in the sections below 3.
- C. Forward the saved copy of this form to the Standards Holder via email.
 - 1. Email to: melissa.lopez2@imail.org
- D. The Standards Holder will then review and evaluate the request. The requestor should be prepared to provide plans, specifications, and competitive bids if requested. Any email threads or meeting discussions regarding the issue will be taken into consideration.

- E. The Standards Holder will then cast an Approve or Deny vote and forward the request to the DCO Manager for a decision.
- F. When the decision has been made by the Operations Manager, the Standards Holder will then notify the requestor by returning the completed and signed form via email.
- G. An approved deviation will have the final disposition button 'Approved' and be signed by at least 2 people. One will be from the Standards Holder, and the other the DCO Manager. Other signatures may be required for specific features and areas such as Safety, Security, Print, Medical group, etc.

PART 3 - EXECUTION

3.1 POST DECISION EXECUTION

- A. DENIED
 - 1. If the requester is not satisfied with the decision, they may file an appeal with the Data Center Operations manager (shawn.folkman@imail.org), who will then escalate the issue to the appropriate business leaders as needed. The decision from the appeal is final.
- B. APPROVED
 - 1. If a deviation is approved for contracted material, labor, or method; the facilities project manager will arrange for fulfillment or contract adjustment as needed via appropriate contract channels such as change orders.

END OF SECTION

SECTION 276002

APPENDIX 02 – DOCUMENT REFRESH PROCESS

PART 1 - GENERAL

1.1 NOT USED

PART 2 - PRODUCTS

2.1 APPROVED PRODUCT

- A. The purpose of this section is to help ensure a current standards document.
- B. The product delivered will be a current revision or version of the Cable Plant Standards Document.
- C. All changes must be approved by Enterprise Infrastructure Cabling team.

PART 3 - EXECUTION

3.1 REVIEWS AND UPDATES

- A. Minor updates
 - 1. Changes that do not significantly affect scope of work, or contract pricing will be made, and the Rev number will be updated. (i.e. updated part numbers, etc.)
 - 2. Significant changes will be added to the Change Log for review and approval from the DCO/Infrastructure Cabling Team.
 - a. When approved, they will be submitted for approval; and then implemented in the new Version.
- B. Major updates
 - 1. The DCO/Infrastructure Cabling Team will review the entire document at least once every three years.
 - 2. This review will coincide with the release of new versions of NFPA70 (National Electrical Code) (2017, 2020, etc. - to be completed by the end of each designated year).
 - 3. The review will cover standards adjustments that may be deemed necessary and ensure compliance with applicable codes and standards.
 - 4. Upon completion of the reviews and updates, the standards document will be submitted for approval.

END OF SECTION

THIS PAGE LEFT BLANK INTENTIONALLY

SECTION 276003

APPENDIX 03 – DATA CENTER, TEC, TDR PART NUMBERS

ITEM	MANUFACTURER	PART NO.	DESCRIPTION
Blanking Panel	Upsite Hotlok	10031	Blanking Panel 1U
Blanking Panel	Upsite Hotlok	10033	Blanking Panel 2U
UPS	Eaton	9PX1500R	Eaton Powerware 9PX-1500V
UPS Network Card	Eaton	NETWORK-M	Card for 9PX-1500VA
PDU	Eaton	ePBZ79	Horizontal Mount ePDU 208vac
PDU	Eaton	ePBZ82	Horizontal Mount ePDU 120vac
PDU	Server Technology	C1S24VS-YCFA13C9	Vertical 30A PDU (Blue) for TEC
PDU	Server Technology	C1L24VS-YCFA13C9	Vertical 30A PDU (Red) for TEC
PDU	Server Technology	C2SG36TE-YCMFAM66/C	Vertical 30A PDU (Blue) for Data Centers
PDU	Server Technology	C2LG36TE-YCMFAM66/C	Vertical 30A PDU (Red) for Data Centers
PDU	Server Technology	C2SG36TE-DQME2M66/ZB	Vertical 60A PDU (Blue) for Data Centers
PDU	Server Technology	C2LG36TE-DQME2M66/ZR	Vertical 60A PDU (Red) for Data Centers
UPS	Eaton	K41512000000000	Eaton 9155-15kVA UPS
Modbus Card	Eaton	103005425-5591	Eaton Modbus Card X-Slot
Reverse Transfer UPS System	Eaton	9GPV15C0009E00R2	Eaton 93PM-150kW Reverse Transfer UPS System
CRAC Cooling Unit	Liebert	DE363G	
Vertical Wall Mount Cabinets	Legrand	VWMSD-4RU-42-B	42" 12" 4RU Fixed
Vertical Wall Mount Cabinets	Legrand	VWMSD-8RU-42-B	42" 18" 8RU Fixed
Rail Accessories	Legrand	VWM-RR-4RU	Fixed Mounting Rail Kit, 4RU
Rail Accessories	Legrand	VWM-RR-8RU	Fixed Mounting Rail Kit, 8RU
Rail Accessories	Legrand	VWM-PIV-4RU	Pivoting Mounting Rail Kit, 4RU
Fan Kit	Legrand	VWMFK-115	VWM Fan Kit w/115 VAC Fans (includes 2 fans and mounting hardware) (2 kits needed for 8RU cabinet)
VWM Top Brush Grommet Kit	Legrand	VWMBGK	VWM Top Brush Grommet Kit
Circular Knockout Grommet Kit	Legrand	VWMGR-30	Circular Knockout Grommet Kit
Vertical Wall-Mount Cabinets	Hubbell	IR221APG	Refrigerated cabinet 24"
Vertical Wall-Mount Cabinets	Hubbell	IR321APG	Refrigerated cabinet 36"
Vertical Wall-Mount Cabinets	Hubbell	IR421APG	Refrigerated cabinet 48"
Air Conditioners	Hubbell	IRAC1	Air conditioner for Hubbell refrigerated cabinets
Cylinder	Medeco	100500 G	1 ¼" Mortise Cylinder
Cylinder	Medeco	100400H G	Rim Cylinder, Horizontal Tailpiece
Cylinder	Medeco	EA-100108	Small Format Interchangeable Core (SFIC) Cylinder
Cylinder	Medeco	20200S1 G	Cylinder Package for Schlage
Cam Lock	Medeco	EN-150002-219	7/8" Cam Lock Assembly, Key Retaining

Cam Lock	Medeco	EN-150003-219	1 1/8" Cam Lock Assembly, Key Retaining
Cylinder for Legrand cabinet front door	Medeco	232301S 800 G	Modular Profile Cylinder – 30mm Half Profile - Assembled
Electronic Key	Medeco	94-0271	Medeco Slim Line Key (G2) & Charger Bundle
Programming Station for Small Locations	Medeco	EA-100109	Medeco XT Desktop USB Programming Station (not preferred)
Programming Station for Large Locations	Medeco	EA-100158	Medeco XT Wall USB Programming Station (preferred)
Wall Mount for Wall Programmer	Medeco	94-0294	Medeco XT Remote Wall Programmer Wall Mount Kit
Padlock for use with Electronic Cylinder	Master	6842D045KZ	Padlock
Red C20 C19 Dual Lock 12 gauge 6'	Stay Online	5914	Red C20 C19 Dual Lock 12 gauge 6'
Blue C20 C19 Dual Lock 12 gauge 6'	Stay Online	6766	Blue C20 C19 Dual Lock 12 gauge 6'
Red C14 Locking C15 Notched 14 gauge 6'	Stay Online	9144	Red C14 Locking C15 Notched 14 gauge 6'
Blue C14 Locking C15 Notched 14 gauge 6'	Stay Online	9138	Blue C14 Locking C15 Notched 14 gauge 6'
Red C14 C13 Dual Lock 18 gauge 6'	Stay Online	5656	Red C14 C13 Dual Lock 18 gauge 6'
Blue C14 C13 Dual Lock 18 gauge 6'	Stay Online	6694	Blue C14 C13 Dual Lock 18 gauge 6'

SECTION 276004

APPENDIX 04 – REFERENCE STANDARDS

PART 1 - GENERAL

1.1 REFERENCE STANDARDS

- A. Codes and Standards (Most recent editions with addenda/TSB, etc.) All materials, installation and workmanship shall meet or exceed the applicable requirements and standards addressed within the references listed below:
1. ANSI/TIA-568.0-D and addenda “Generic Telecommunications Cabling for Customer Premises
 2. ANSI/TIA-568.1-D and addenda “Commercial Building Telecommunications Cabling Standard
 3. ANSI/TIA-568.2-D and addenda “Balanced Twisted-Pair Telecommunications Cabling and Components
 4. ANSI/TIA-568.3-D and addenda “Optical Fiber Cabling Components Standard”
 5. ANSI/TIA-568.4-D and addenda “Broadband Coaxial Cabling and Components Standard”
 6. ANSI/TIA-569-D and addenda “Telecommunications Pathways and Spaces”
 7. ANSI/TIA-606-C and addenda “Administration Standard for Commercial Telecommunications Infrastructure”
 8. ANSI/TIA-607-D and addenda “Generic Telecommunications Bonding and Grounding (Earthing) for Customer Premises”
 9. ANSI/TIA-758-B “Customer-Owned Outside Plant Telecommunication Infrastructure Standard”
 10. IEEE 802.3at PoE Plus and Next Gen PoE CFI March 2013 and IEEE P802.3ba latest draft revision and amendments.
 11. “Media Access Control Parameters, Physical Layers and Management Parameters for 40 Gbp/s and 100 Gbp/s Operation”.
 12. ANSI/TIA-526-7-A “Measurement of Optical Power Loss of Installed Single-Mode Fiber Cable Plant”
 13. ANSI/TIA/EIA-526-14-C “Optical Power Loss Measurements of Installed Multimode Fiber Cable Plant”
 14. ANSI/TIA-942-B “Telecommunications Infrastructure Standard for Data Centers”
 15. ANSI/TIA – 1179-A “Healthcare Facility Telecommunications Infrastructure Standard”
 16. IEC/TR3 61000-5-2 - Ed. 1.0 and amendments “Electromagnetic compatibility (EMC) - Part 5: Installation and mitigation guidelines - Section 2: Earthing and cabling”
 17. ISO/IEC 11801-1 (2017) and amendments “Information technology - Generic cabling for customer premises – PART 1: General Requirements”
 18. EN 50173-1 and amendments “Information Technology - Generic cabling systems – PART 1 General Requirements”
 19. AIA Guidelines for Design and Construction of Hospital and Healthcare Facilities
 20. Construction Specification Institute Master Format
 21. BICSI: Comply with the most current editions of the following BICSI manuals:
 - a. BICSI - Telecommunications Distribution Methods Manual
 - b. BICSI – Installation Transport Systems Information Manual
 - c. BICSI – Network Design Reference Design Manual
 - d. BICSI – Outside Plant Design Reference Manual
 - e. BICSI – Wireless Design Reference Manual
 - f. BICSI -Electronic Safety and Security Design Reference Manual

- g. Infocomm/BICSI – AV Design Reference Manual
- 22. Underwriters Laboratories (UL) Cable Certification and Follow-Up Program.
- 23. National Electrical Manufacturers Association (NEMA)
- 24. American Society for Testing Materials (ASTM)
- 25. National Electrical Code (NEC) NFPA70 2020
- 26. National Electrical Safety Code (NESC) 2017
- 27. Institute of Electrical and Electronic Engineers (IEEE)
- 28. UL Testing Bulletin
- 29. Building Industry Consulting Services International (BICSI) Information Transport Systems Methods Manual (ITSMM)
- 30. Local, county, state and federal regulations and codes in effect as of date of installation.
- 31. Equipment of foreign manufacture must meet U.S. codes and standards. It shall be indicated in the proposal the components that may be of foreign manufacture, if any, and the country of origin.

END OF SECTION

SECTION 276005

APPENDIX 05 – DEFINITIONS AND ABBREVIATIONS

PART 1 - GENERAL

1.1 RELATED TERMS

- A. Codes and Standards (Most recent editions with addenda/TSB, etc.) All materials, installation and workmanship shall meet or exceed the applicable requirements and standards addressed within the references listed below:
1. Basket Cable Tray: A fabricated structure consisting of wire mesh bottom and side rails.
 2. BICSI: Building Industry Consulting Service International.
 3. CBC: Coupled Bonding Conductor
 4. CFCI: Customer Furnished Customer Installed
 5. Cable Run - A single cable to a single location
 6. Cable Drop - Two cables to a single location
 7. Cable Tri Drop - Three cables to a single location
 8. CT Coupler A type of wall connector made by the Siemon Company
 9. DCO: Data Center Operations
 10. Div.1: Division 1 General and Performance Requirements
 11. Div. 23: Division 23 Heating, Ventilating, and Air Conditioning
 12. Div. 22: Division 22 Plumbing
 13. Div. 26: Division 26 Electrical
 14. Div. 27: Division 27 Communications and Audio Visual
 15. Div. 28: Division 28 Electronic Safety and Security
 16. E.E.: Electrical Engineer
 17. EMI: Electromagnetic Interference
 18. F/UTP: Foil over Unshielded Twisted Pair. Individual pairs are unshielded.
 19. GC: General Contractor
 20. GE: Ground Equalizer
 21. Horizontal Cabling: The cable and connecting hardware utilized to transport communications signals
 22. ICT: Infrastructure Cabling Team
 23. LAN: Local Area Network
 24. N/A: Not Applicable
 25. NIC: Not in Contract
 26. OFCI: Owner Furnished Contractor Installed
 27. OFOI: Owner Furnished Owner Installed
 28. OTDR: Optical Time Domain Reflectometer
 29. Outlet/Connectors: A connecting device in the work area on which horizontal cable or outlet cable terminates.
 30. RCDD: Registered Communications Distribution Designer
 31. RFI: Radio Frequency Interference
 32. TBA or TBD: To Be Determined
 33. TDR: Technology Distribution Room
 34. TEC: Technology Equipment Center
 35. TGB: Telecommunications Ground Bus Bar
 36. TMBC: Telecommunications Main Bonding Conductor
 37. TMGB: Telecommunications Main Grounding Bus Bar
 38. TSER: Telecommunications Service Entrance Room
 39. UTP: Unshielded Twisted Pair
 40. Work Area: approx. 100 sq. ft. equipped for workstation equipment

- 41. DCO = Data Center Operations – Boe.Sausedo@imail.org
- 42. ICT = Information and Communications Technology – Melissa.Lopez2@imail.org

END OF SECTION

SECTION 276006

APPENDIX 06 – MATERIAL SUPPLIERS

PART 1 - GENERAL

1.1 RELATED TERMS

- A. Siemon Authorized Suppliers are listed below. To help prevent counterfeiting and support warranties, known, factory authorized distributors are recommended.
1. Approved Suppliers of Siemon cable, patch panels, jacks, and parts:

Anixter

Randi Whittaker
Inside Sales
3775 W. California Ave. Ste 400
Salt Lake City, UT 84104 US
Main Phone: (801) 973-2121
Fax: (801) 973-4472
Email: randi.whittaker@anixter.com

Karl Bartlam
End User/Outside Sales
3775 W. California Ave. Ste 400
Salt Lake City, UT 84104 US
Main Phone: (801) 973-2121
Fax: (801) 973-4472
Email: karl.bartlam@anixter.com

Graybar Electric

Elizabeth Vaughn
Inside Sales
2841 South 900 West
Salt Lake City, UT 84119 US
Main Phone: (801) 656-3016
Fax: (801) 973-4314
Email: Elizabeth.Vaughn@graybar.com

Erika Morrison
Contractor Outside Sales
2841 South 900 West
Salt Lake City, UT 84119 US
Main Phone: (801) 656-3014
Fax: (801) 973-4314
Email: Erika.Morrison@graybar.com

WESCO / CSC

Brian Walters
Inside Sales
3210 South 900 West
Salt Lake City, UT 84119 US
Main Phone: (801) 975-0600
Fax: (801) 907-4450
Email: Bwalters@gocsc.com

Adam Tueller
Contractor Outside Sales
3210 South 900 West
Salt Lake City, UT 84119 US
Main Phone: (801) 975-0600
Direct: (801) 618-6665
Email: Atueller@wesco.com

- B. The Siemon Company is represented locally by: Marc.Lovestrand@Siemon.com

END OF SECTION

THIS PAGE LEFT BLANK INTENTIONALLY

SECTION 276007

APPENDIX 07 – SIEMON CERTIFIED INSTALLATION FIRMS

PART 1 - GENERAL

1.1 RELATED TERMS

- A. NOTE: Cable installers have rigorous requirements to be certified for Siemon cables and products. Validation of certification is required prior to accepting a bid.
- B. The firms selected to bid must be pre-approved by the local facility IT manager. Installation firms desiring to do work for Intermountain Healthcare must be selected from the official CI list below.
- C. Current Siemon Approved/Certified Cable Installers for Siemon Network Cable. This list is up to date as of 2018-12-01.
1. **Orion Integration Group:** 8880 W. Barnes Street, Boise, ID 83709 / Phone 208 321 8000
 2. **ACS Systems:** 925 North Main St. Meridian, ID 83642 / Phone 208 331 8554
 3. **IES Commercial:** 1960 S. Milestone, Suite D, Salt Lake City, UT 84104
 - a. Jason King – Branch Manager // Phone 801 975 8182 / Fax 385 242 7366 / Mobile 801 381 1508 // Jason.King@iescomm.com / www.iescomm.com
 - b. Boyd Evans – Project Manager // Phone 801 975 8191 / Fax 385 242 7366 / Mobile 801 381 1518 // Boyd.Evans@iescomm.com / www.iescomm.com
 4. **Cache Valley Electric:** 1338 S. Gustin Rd., Salt Lake City, UT 84104
 - a. Travis Grant – Acct. Manager // Phone 801 908 4170 / Fax 801 908 7401 / Mobile 801 870 7226 // Travis.Grant@cve.com / www.cve.com
 - b. Brad Readicker – Acct. Manager // Phone 801 908 2686 / Fax 801 908 7401 // Brad.Readicker@cve.com / www.cve.com
 5. **Data Tech Professionals:** 1199 S 520 W, Payson, UT 84651
 - a. Jesse Pierce – President // Phone 801 960 2202 / Mobile 801 420 0463 // Jesse@datatechprofessionals.com / www.datatechprofessionals.com
 6. **Hunt Electric, Inc.:** 1863 W. Alexander St., Salt Lake City, UT 84119
 - a. Darrin Guevara – Division Manager // Phone 801 975 8844 // Darrin@huntelelectric.com / www.huntelelectric.com
 7. **NCNS Communications:** 419 West Universal Circle, Sandy, UT 84070
 - a. Jayson Nosack – Owner // Phone 801 361 4572 // Jnosack@ncns-co.com / www.ncns-co.com
 8. **Data Plus:** 769 Middlegate Road, Henderson, NV 89118
 - a. Chris Tettamanti – Project Manager // Phone 702 795 3282 // Chris@dpcnv.com
 9. **Bombard Electric:** 4380 West post Road, Las Vegas, NV 89118
 - a. Bob Reese – Project/Division Manager // Phone 702 263 3570 // Bob.reese@bombardelec.com / www.bombardelectric.com
 10. **Rosendin Electric:** 7470 Dean Martin Dr. #112, Las Vegas, NV 89139
 - a. Cora Shadbolt – Assistant Project Mgr. // Phone 702 258 1443 // cshadbolt@rosendin.com
 - b. Adrian Youngblood – Sr. Estimator // Phone 702 258 1455 // ayoungblood@rosendin.com
 - c. Breck Hardesty – Sr. Project Mgr. // Phone 702 258 1428 // bhardesty@rosendin.com / www.rosendin.com

11. **Mojave Electric:** 3755 W. Hacienda Ave., Las Vegas, NV 89118
Phone 702 798 2970
12. **The Morse Group:** 3874 Silvestri Lane, Las Vegas, NV 89120
Phone 702 257 4400

END OF SECTION

SECTION 276008

APPENDIX 08 – LEAD WALL PENETRATIONS

PART 1 - GENERAL

1.1 RELATED DOCUMENTS

- A. Sections 13090 & 134900

1.2 RELATED TERMS

Procedure Name: New Port and Electrical Box Installation Lead Lined Walls

Document Detail Information: (This section must be completed in full.)

Implements Policy:	Click here to enter policy title		
Content Owner	Craig Allen, Safety Security Environment Health Director, Central Office Jeremy Hawk Medical Physicist Radiation Safety Coordinator	Content Consultant(s):	Jeremy Hawk, Radiation Safety Officer, Medical Physicist Imaging John Ellis, Facilities Management Director, Central Office Steve Kelly, System Project Facility Design Manager, Planning Melissa Lopez, Cabling, IS
Date of Final Draft:	12/29/2015	Who Reviewed Content?	<Name, Title, Dept> <Name, Title, Dept> <Name, Title, Dept> <Committee Name>
Keywords (must have at least 3):	Searchable Keywords (e.g., PHI, EMTALA, Coding)		

1.3 PURPOSE

- A. Maintain radiation safety controls in lead lined walls during installation of new power and data outlets in existing lead lined walls.

1.4 SCOPE

- A. Intermountain Hospitals, Intermountain Clinics Medical Group

1.5 DEFINITIONS

- A. Lead lined Walls – Structured element designed to provide a barrier to block radiation penetration beyond the designated space.
- B. Maintenance Manager – The person responsible for plant maintenance operations or his/her delegate.
- C. Radiation Safety Coordinator – The person responsible for Radiation Safety or his/her

Delegate. Medical Physicist.

- D. Worker – The person responsible for completing work with the lead lined wall. This includes Intermountain Employees as well as any outside supplier or contractor.

1.6 PROVISIONS

- A. The Radiation Safety Program is following Utah regulation R313-15-101, R313-28 and U.S. Nuclear Regulatory Commission Regulation 1- CFR Part 20-1101.

1.7 PROCEDURE

- A. Prior to any work within a lead lined wall, the Worker reports to the Radiation Safety Coordinator, Maintenance Manager and completed a review of planned work “ACWP” Identification of specific description related to the lead lined wall planned work.
 - 1. Intermountain workers, outside suppliers or contractors hired to work in any Intermountain facility must contact the Maintenance Manager and Radiation Safety Coordinator prior to beginning work to discuss the project and ensure that the planned work will not interfere with facility operations, maintenance, or other projects.
 - 2. Failure to scheduled and complete the planning meeting described above may results in the delay or rescheduling of work. Outside suppliers or contractors are responsible for any costs incurred because of their failure to schedule and complete this meeting.
- B. The Radiation Safety Coordinator, Maintenance Manager and the worker conduct a pre-work inspection of the areas in which work is to be performed. This inspection identified the following:
 - 1. Areas of special concern or sensitivity, including those noted or described on the facility Life Safety records and drawings, and Radiation Safety records and drawings.
 - 2. Appropriate areas or structures to use for support of any work, as applicable.
 - 3. Existing deficiencies in Barriers.
 - 4. The as act assemblies impacted by the work.
 - 5. The type of shielding material acceptable in the area.
 - a. Lead lined boxes
 - b. Lead lined wall “inside wall” installation, and OR
 - c. Lead shielding for wall installation of “outside wall” maintaining radiation safety barriers.
 - 6. The exact condition of the areas upon completion of work.
- C. Upon completion of the work and before closing the wall, the worker, Radiation Safety Coordinator and Maintenance Manager conduct a post-work inspection of the area in which the work was performed, this inspection verifies the following:
 - 1. No Tools, Supplies or debris are left within the walls.
 - 2. Lead lining is installed to maintain radiation safety protection according to regulatory requirements.
 - 3. All work affecting Radiation Safety Lead Barriers has been properly sealed.
 - 4. The overall condition of the area meets the expectation outline in the per-work inspection.
- E. The Maintenance Manager and Radiation Safety Coordinator signs and logs the completed “ACWP”

1.8 EXCEPTIONS

- A. None.

1.9 PRIMARY SOURCES

- A. List the regulatory references upon which the procedure is based (cite the code, the title, and the statute).

1.10 SECONDARY MATERIALS

- A. Radiation Safety Policy
 B. Above Ceiling Work Permit
 C. Lead lined wall requirements as defined by Radiation Safety Building Requirements

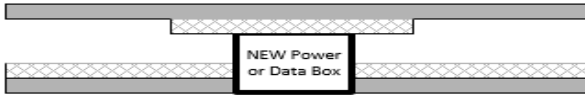

Option 1: worker to install new power utility wall box and add Lead Lining to wall behind box
 If worker can access posterior wall entry



Option 2: worker to install new power utility wall box – box is lead Lined by manufacturer



Option 3: worker to install new power utility wall box - no additional lead lining required if installation does not disrupt the existing shielding

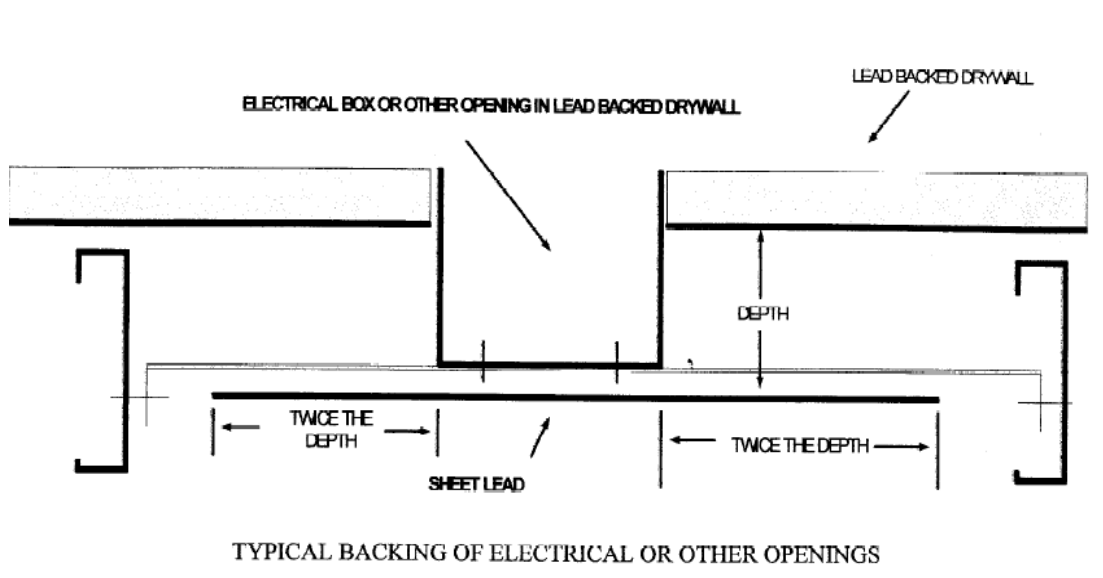

END OF SECTION

THIS PAGE LEFT BLANK INTENTIONALLY

DIVISION 28 – ELECTRONIC SAFETY AND SECURITY

Section 28 1300	Access Control	Section 28 2300 Video Surveillance
Section 28 2300	Video Surveillance	
Section 28 3111	Digital, Addressable Fire-Alarm System	

THIS PAGE LEFT BLANK INTENTIONALLY

SECTION 28 13 00
ACCESS CONTROL

PART 1 - GENERAL

1.1 RELATED DOCUMENTS

- A. Drawings and general provisions of the Contract, including General and Supplementary Conditions and Division 01 Specification Sections, apply to this Section.

1.2 SUMMARY

- A. This section includes a complete installation of a PC based and managed access control and security system (Lenel) and specifies sensors, signal equipment, and system controls. The Lenel system shall be capable of functioning with both standard wired locks and card readers as well as with network connected integrated hardware.
- B. The electrified locking and access hardware for this project is specified using ASSA ABLOY products that will require the security contractor to provide integrated access control connection locking devices and wire harnesses. Locking devices are specified to use either POE or standard wiring connections. Cabling for the POE locking devices shall be provided by Div 27 contractors with the security contractor providing the cabling for non-POE locking hardware.
- C. The system shall also interface with wireless access control for medical cabinets and refrigerators via wired hubs. Aperio IP hubs shall be provided for the wireless communication and wired connections back to the network patch panels. Provide optional external antenna with each hub.

1.3 DEFINITIONS

- A. Hard-Wired System: Alarm, supervisory, and detection devices are directly connected, through individual dedicated conductors, to central control panels.

1.4 SYSTEM DESCRIPTION

- A. The system shall have both access-controlled doors and alarm inputs for panic buttons and intrusion detection.
- B. The system shall support automatic responses to alarms entering the system. Each alarm condition shall be capable of initiating numerous events including but not limited to: Activation of remote devices, door control, remote annunciation LED's, and card validation.
- C. Access control functions shall include but not be limited to: Validation based on time of day and day of week, holiday scheduling with card validation override, and access validation based on positive verification of card.

- D. The system shall interface with the fire alarm system and in the event of an alarm, shall release all controlled doors designated for emergency egress, and put them in fail-safe mode allowing free egress.
- E. User selected installer: CONVERGINT TECHNOLOGIES.

1.5 FUNCTIONAL PERFORMANCE

- A. The system shall consist of a network controller and network nodes using a standard TCP/IP network. Each controller shall retain all data necessary for system operation in its own RAM. Each controller will contain an integrated real time clock that continues to govern events even if communication with the main network controller is interrupted.
- B. The network controller shall act as an interface point with the node network, a data base management tool, and a transaction storage device.

1.6 ACTION SUBMITTALS

- A. General: Submit the following according to Conditions of Contract and Division 1 Specification Sections
- B. Product data for system components, including "Nationally Recognized Testing Laboratory" (NRTL) listing data and list of materials, dimensioned plans, sections, and elevations showing minimum clearances, mounting arrangements, and installed features and devices.
- C. Wiring Diagrams and Door Elevations: Provide the following for each opening having electric hardware, except doors with only magnetic holder/release units.
 - 1. Wiring diagrams for scheduled items requiring power. Identify manufacturer-installed and field-installed wiring.
 - 2. Provide load calculations and requirements for each electro-mechanical locking device within +/-5% of 24 VDC. Size the conductors for each device appropriately to maintain this requirement.
 - 3. Provide cable type (as indicated on the Shop Drawings Wire Legend) that is used for each electro-mechanical locking device, the conductor size, the estimated total length of cable, the estimated line loss (voltage drop), and the percentage of estimated line loss (voltage drop).
- D. System operation description, including method of operation and supervision of each component and each type of circuit, and sequence of operations for all manually and automatically initiated system inputs. Description must cover this specific Project; manufacturer's standard descriptions for generic systems are not acceptable.

1.7 CLOSEOUT SUBMITTALS

- A. Operation and maintenance data for inclusion in "Operating and Maintenance Manual" specified in Division 01. Include data for each type product, including all features and operating sequences, both automatic and manual. Include user's software data and recommendations for spare parts to be stocked at the site. Provide names, addresses, and telephone numbers of service organizations that stock repair parts for the system.

- B. Product certifications signed by the manufacturers of system components certifying that their products comply with the referenced standards.
- C. Separate Qualification Data for Manufacturers and Installers: Demonstrate their capabilities and experience as specified in Quality Assurance Article. Include lists of completed projects with project names and addresses, names of Contracting Officer and Government representatives, plus other information specified.
- D. Record of field tests of system.

1.8 QUALITY ASSURANCE

- A. Comply with NFPA 70, "National Electrical Code."
- B. Listing and Labeling: Provide system and components that are listed and labeled for their indicated use and location on the Project.
 - 1. The Terms "Listed" and "Labeled": As defined in the "National Electrical Code," Article 100.
 - 2. Listing and Labeling Agency Qualifications: A "Nationally Recognized Testing Laboratory" (NRTL) as defined in OSHA Regulation 1910.7.
- C. Comply with UL Standard 609, 1023, and 1076.
- D. FM Compliance: Provide FM approved card access system and components.
- E. Single Source Responsibility: Obtain system components from a single source (the prime system manufacturer) that assumes responsibility for system components and for their compatibility.
- F. The successful bidding contractor shall be required to have training and accreditation with both ASSA ABLOY and Lenel. The approved installer is Converjint Technologies or Robert I. Merrill

1.9 COORDINATION

- A. Access Control System Electrical Coordination: Coordinate with the layout and installation of scheduled electrified door hardware, and related access control equipment, with required connections to source power junction boxes, power supplies, detection and monitoring hardware and fire alarm system.
 - 1. Door Hardware Interface: The card access control system shall be connected to electronic door control hardware (electromechanical locks, electric strikes, magnetic locks, door position switches, other monitoring contacts, and related auxiliary control devices) as described under Division 8 "Door Hardware". Coordinate with the installation and configuration of specified door hardware being monitored or controlled with the controls, software and access control hardware specified in this Section.
 - 2. Access Control Hardware Sets: The hardware sets listed represent the design intent and direction of the owner and architect. They are a guideline only and should not be considered a detailed hardware schedule. Discrepancies, conflicting hardware and missing items should be brought to the attention of the architect with corrections made prior to the bidding process. Omitted items not included in a hardware set should be scheduled with the appropriate additional

hardware required for proper application and functionality. **Refer to Section 08 71 00 Door Hardware Schedule for hardware set information.**

3. Fire Alarm Interface: Review Door Hardware Schedule for sequence of operation requiring an interface with the fire alarm system, such as release upon fire alarm. Coordinate with the fire alarm installer to provide all fire alarm system components to accomplish the specified sequence of operation. Provide fire alarm release at all delayed egress doors and any other doors in the path of egress that are allowed to be locked.

PART 2 - PRODUCTS

2.1 MANUFACTURERS

- A. Manufacturers: Subject to compliance with requirements, provide products by one of the following:
 1. Continental 3000

2.2 ACCESS CONTROL SYSTEM EQUIPMENT, GENERAL

- A. Surge Protection: Comply with minimum requirements of UL Standard 1449, "Transient Voltage Surge Suppressors," for each component using solid state devices and having a line voltage power source connection or an exterior underground signal connection.
- B. Provide at the locations identified, a complete and operational Access Control and Security System including but not limited to the following equipment:
 1. Card Readers
 2. Door Logic Panels
 3. Relay output contacts
 4. All power supplies and/or transformers
 5. All equipment, security devices, components, wire, cable, and mounting hardware as required to meet specification requirements and manufacturers documented installation procedures.
- C. Provide the quantity of new door licenses to the existing Lenel building package to accommodate the increased number of readers being added as part of this project.

2.3 PHYSICAL SECURITY APPLIANCE

- A. Physical Security Appliance (PSA): Stand-alone, modular multi-reader access controller shall be provided for standard door opening access control. The appliances shall communicate to the main system server using Ethernet TCP/IP, and shall serve as the data collection and communications interface between the system server and the various field devices such as card readers, alarm inputs and control outputs.
- B. Power Requirements: Each Physical Security Appliance (PSA) shall accept a power input voltage of 120 VAC, 60Hz. Maximum power draw shall be no more than 300W. The PSA shall generate appropriate DC voltage levels for on-board use as required. External lock power supplies shall be required and sized for the appropriate number of

locks (plus 20%) associated with each distributed controller. All power outputs to external devices shall be current limited in accordance with class 2 power limited wiring standards

- C. Battery Backup: The power supplies inherent in the PSA shall have the capability of charging standard gel-cell batteries, and shall be capable of operating on direct battery backup. The PSA shall be capable of providing at least four hours of full operation backup time, and shall be capable of recharging its batteries in less than 48 hours. Batteries shall be mounted in a separate, dedicated battery shelf sized to contain the amount of batteries required.

2.4 ELECTRICAL POWER

- A. Normal System Power Supply: 120 V 60 Hz from locked disconnect device. System components are supplied with power through separate power supplies. Provide all required power supplies and associated transformers as specified by the manufacturer.
- B. Power Source Transfer: When normal power is interrupted, system is automatically switched to backup supply without degradation of critical system function or loss of signals or status data.
 - 1. Backup Source: Batteries in power supplies of individual system components. Such batteries are an integral part of power supplies of the components.
 - 2. Annunciation: Switching of the system or any system component to backup power is indicated as a change in system condition.

2.5 CARD ACCESS SYSTEM HARDWARE, GENERAL

- A. Types, features, accessories, and mounting conditions of individual devices are as indicated.
- B. Battery Backup: The access control panel shall be provided with back up battery power for up to four hours operation upon loss of AC power.
- C. Suppression: The access control panel shall have provisions for relay suppressor kits for each relay used, to protect the access control panel from collapsing electrical fields.
- D. Card Readers: Card readers shall be HID iClass SE readers.
 - 1. Proximity Readers: The system shall be provided with uni directional proximity card readers. The standard iClass SE readers shall have a read range of five to eight inches. The reader shall be able to be mounted with its sides against metal door or window frames, and masonry walls. Long range readers mounted at vehicle gates shall have a minimum 10 inch read range.
 - a. Standard readers: HID R40
 - b. Keypad/Pinpad: HID RK40
 - c. Mullion Installation: HID R15

2.6 POWER SUPPLIES

- A. Provide power supplies as per manufacturers written recommendations with total number of powered devices for each power supply restricted to only consuming 75 percent of the power supplies rated amperage. Provide separate power supplies for

system controllers (As per manufacturer), card readers (12VDC, 5 A), and locks (24 VDC, 7 A).

2.7 CONTACT INDICATOR SWITCHES

- A. Contact indicators on overhead doors that are not supplied by the door manufacturer shall be Sentrol series 2300 type surface mounted magnetic reed type switches with opposing magnet, and shall be per manufacturer's recommendations for the type of door.

2.8 WIRE AND CABLE

- A. Cables: Bundled, shielded and unshielded, twisted-pair cable, shielded where manufacturer recommends shielded cable for standard readers and locking hardware. Cat 6A cable shall be provided by Div 27 to all network connected locking hardware.
 - 1. Specified Manufacturer: Provide the specified product or prior approved equal.
 - a. Coleman Cable Inc. (CCI) Part Number 73101 consisting the following cables bundled plenum rated within a yellow Low Smoke PVC, CMP/CL3P/FPLP jacket:
 - 1) PN 72321: 22 AWG 2/Conductor CMP. Typical use, Door Contact
 - 2) PN 72344: 22 AWG 4/Conductor CMP. Typical use, Request to Exit/Spare
 - 3) PN 75366: 22 AWG 6/Conductor shielded CMP. Typical use, Card Reader.
 - 4) PN 71944: 18 AWG 4/Conductor CMP. Typical use, Lock Power
 - b. Any of the above cables may be used individually where cables in addition to those included in the bundle are required.
- B. Comply with Division 26 Section "Wires and Cables" except as indicated.
- C. Cable for Low Voltage Control and Signal Circuits: Shielded twisted pair cable with drain. Comply with Division 26 Section "Wires and Cables."

2.9 RACEWAY

- A. Comply with Division 26 Section "Raceways."

2.10 DOOR HARDWARE SCHEDULE

- A. Refer to Section 08 71 00 Door Hardware Schedule for hardware set information and assignment of required components to be provided by the Division 28 contractor.

PART 3 - EXECUTION

3.1 EXAMINATION

- A. Examine pathway elements intended for cables. Check raceways, cable trays, and other elements for compliance with space allocations, installation tolerances, hazards to cable installation, and other conditions affecting installation.

- B. Examine roughing-in for card readers, and other cable-connected devices to verify actual locations of conduit and back boxes before device installation.
- C. Proceed with installation only after unsatisfactory conditions have been corrected.

3.2 PREPARATION

- A. Comply with recommendations in SIA CP-01.
- B. Comply with TIA/EIA 606-A, "Administration Standard for Commercial Telecommunications Infrastructure."
- C. Obtain detailed Project planning forms from manufacturer of access-control system; develop custom forms to suit Project. Fill in all data available from Project plans and specifications and publish as Project planning documents for review and approval.
 - 1. For each Location, record setup of controller features and access requirements.
 - 2. Prepare a specific plan for system testing, startup, and demonstration.
 - 3. Develop acceptance test concept and, on approval, develop specifics of the test.
 - 4. Develop cable and asset-management system details; input data from construction documents.

3.3 INSTALLATION

- A. General: Install system according to NFPA 70, applicable codes, and manufacturer's printed instructions.
- B. Wiring Method:
 - 1. Concealed in walls or above inaccessible ceilings: Install all cabling in raceways, 1inch minimum. Conduit fill shall not exceed 40%.
 - 2. Above Accessible Ceilings: Provide J-Hooks at not more than 5 feet on center. Fasten J-Hooks to walls with solid anchoring to studs. Where wall are unavailable suspend from structure using not less than 3/8" diameter threaded rod and provide tie to ceiling grid to prevent sway.
 - 3. Exposed: Install exposed cables in minimum 3/4" galvanized rigid metal conduit with straps at not more than 3 feet on center and minimum 1/4" gap between conduit and building surface. Use boxes that are specified for surface mounting.
- C. Wiring within Panels and Enclosures: Bundle, wrap, and train the conductors to terminal points with 6-inches of slack minimum, 12-inches of slack maximum. Provide and use cable management hardware and distribution spools.
- D. Number of Conductors: As recommended by system manufacturer for functions indicated. As a minimum install one bundled, shielded and unshielded, twisted pair cable for every access controlled door.
- E. Splices, Taps, and Terminations: Make splices, taps, and terminations on numbered terminal strips in junction, pull and outlet boxes, terminal cabinets, and equipment enclosures.
- F. Tighten connections to comply with tightening torques specified in UL Standard 486A.

- G. Identification of Conductors and Cables: Color code conductors and apply wire and cable marking tape to designate wires and cables so media are identified and coordinated with system wiring diagrams.
- H. Install power supplies and other auxiliary components for detection devices at the door controller panel or at a data gathering panel except as otherwise indicated. Do not install such items in the vicinity of the devices they serve.

3.4 GROUNDING

- A. Comply with Section 280526 "Grounding and Bonding for Electronic Safety and Security."
- B. Comply with IEEE 1100, "Recommended Practice for Power and Grounding Electronic Equipment."
- C. Ground cable shields, drain conductors, and equipment to eliminate shock hazard and to minimize ground loops, common-mode returns, noise pickup, cross talk, and other impairments.
- D. Bond shields and drain conductors to ground at only one point in each circuit.

3.5 DOOR RELEASE BUTTON INSTALLATION

- A. Push Buttons: Push-button switches shall be connected to the controller associated with the portal to which they are applied, and shall operate the appropriate electric strike, electric lock, or other facility release device. The system shall also use card readers in place of push-buttons at designated locations for remote operation of access controlled doors.

3.6 IDENTIFICATION

- A. In addition to requirements in this article, comply with applicable requirements in Section 260553 "Identification for Electrical Systems" and with TIA/EIA 606-A.
- B. Label each terminal strip and screw terminal in each cabinet, rack, or panel.
 - 1. All wiring conductors connected to terminal strips shall be individually numbered, and each cable or wiring group being extended from a panel or cabinet to a building-mounted device shall be identified with the name and number of the particular device as shown.
 - 2. Each wire connected to building-mounted devices is not required to be numbered at the device if the color of the wire is consistent with the associated wire connected and numbered within the panel or cabinet.

3.7 FIELD QUALITY CONTROL

- A. Manufacturer's Field Services: Provide services of a factory authorized service representative to supervise the field assembly and connection of components and system pre-testing, testing, adjustment, and programming.

- B. Inspection: Verify that units and controls are properly labeled and interconnecting wires and terminals are identified.
- C. Pre-testing: Align and adjust the system and perform pre-testing of all components, wiring, and functions to verify conformance with specified requirements. Correct deficiencies by replacing malfunctioning or damaged items with new items. Retest until satisfactory performance and conditions are achieved.
- D. Testing: Provide at least 10 days' notice of acceptance test performance schedule.
- E. Operational Tests: Perform operational system tests to verify conformance with specifications. Test all modes of system operation and intrusion detection. Methodically test for false alarms in each zone of space intrusion detection devices by simulating activities outside indicated detection patterns.
- F. Installer Start-up Responsibility: The Installer shall initiate system operation. The Installer shall provide competent start up personnel on each consecutive working day until the system is fully functional. Upon reoccurring technical problems, the Installer shall supply factory direct Manufacturer's support in the form of factory technical representation and/or diagnostic equipment until the resolution of those defined problems.

3.8 ADJUSTMENT

- A. Occupancy Adjustments: When requested within 1 year of date of substantial completion, provide on site assistance in adjusting and reprogramming to suit actual occupied conditions. Provide up to 3 visits to the site for this purpose without additional cost.

3.9 DEMONSTRATION

- A. Train Owner's operating personnel in the programming and operation of the system. Train Owner's maintenance personnel in the procedures and schedules involved in preventive maintenance and in programming, operating, adjusting, troubleshooting, and servicing of the system. Provide a minimum of 4 hours training.
- B. Schedule training with advance notice of at least 7 days.

END OF SECTION

THIS PAGE LEFT BLANK INTENTIONALLY

SECTION 28 23 00
VIDEO SURVEILLANCE

PART 1 - GENERAL

1.1 SUMMARY

- A. Section includes a video surveillance system consisting of cameras, software installation, configuration, and licensing. Network electronics shall be provided by the Owner. Cabling and terminations shall be provided by Section 27 10 00. User selected installer: CONVERGINT TECHNOLOGIES.

1.2 SUBMITTALS

- A. Product Data: For each type of product indicated. Include dimensions and data on features, performance, electrical characteristics, ratings, and finishes.
- B. Shop Drawings: For video surveillance. Include plans, elevations, sections, details, and attachments to other work.
 - 1. Detail equipment assemblies and indicate dimensions, weights, loads, required clearances, method of field assembly, components, and location and size of each field connection.
 - 2. Functional Block Diagram: Show single-line interconnections between components for signal transmission and control. Show cable types and sizes.
 - 3. Dimensioned plan and elevations of equipment racks, control panels, and consoles. Show access and workspace requirements.
 - 4. Wiring Diagrams: For power, signal, and control wiring.
- C. Equipment List: Include every piece of equipment by model number, manufacturer, location, and date of original installation.
- D. Field quality-control reports.
- E. Operation and maintenance data.

1.3 QUALITY ASSURANCE

- A. Electrical Components, Devices, and Accessories: Listed and labeled as defined in NFPA 70, by a qualified testing agency, and marked for intended location and application.
- B. Comply with NECA 1.
- C. Comply with NFPA 70.
- D. Electronic data exchange between video surveillance system with an access-control system shall comply with SIA TVAC.

1.4 WARRANTY

- A. Special Warranty: Manufacturer's standard form in which manufacturer agrees to repair or replace components of cameras, equipment related to camera operation, and control-station equipment that fail in materials or workmanship within specified warranty period.
 - 1. Warranty Period: One year from date of Substantial Completion.

PART 2 - PRODUCTS

2.1 SYSTEM REQUIREMENTS

- A. Video-signal format shall comply with IP based digital transmission.
- B. Surge Protection: Protect components from voltage surges entering through power, communication, signal, control, or sensing leads. Include surge protection for external wiring of each conductor's entry connection to components.
 - 1. Minimum Protection for Power Connections 120 V and More: Auxiliary panel suppressors complying with requirements in Division 26 Section "Transient-Voltage Suppression for Low-Voltage Electrical Power Circuits."
 - 2. Minimum Protection for Communication, Signal, Control, and Low-Voltage Power Connections: Comply with requirements in Division 26 Section "Transient-Voltage Suppression for Low-Voltage Electrical Power Circuits." as recommended by manufacturer for type of line being protected.
- C. Tamper Protection: Tamper protection capability shall be provided as part of the camera manufacture and design.

2.2 CAMERAS

- A. Manufacturers: Subject to compliance with requirements, provide products by one of the following:
 - 1. AXIS
- B. Description: Camera shall be an all-in-one solution with integrated megapixel camera, varifocal lens, and dome enclosure. Refer to camera type schedule in the drawings.

2.3 CAMERA-SUPPORTING EQUIPMENT

- A. Manufacturers: Subject to compliance with requirements, provide products by one of the following:
 - 1. AXIS
- B. Minimum Load Rating: Rated for load in excess of the total weight supported times a minimum safety factor of two.
- C. Mounting Brackets for Fixed Cameras: Type matched to items supported and mounting conditions. Include manual pan-and-tilt adjustment.

- D. Protective Housings for Fixed Cameras: Dome type enclosures with internal camera mounting and connecting provisions that are matched to camera/lens combination and mounting and installing arrangement of camera to be housed. Dome enclosures mounted outside shall be manufactured with environmental features for sustained function in all expected temperatures.

2.4 IP VIDEO MANAGEMENT SYSTEMS

- A. Manufacturers: Subject to compliance with requirements, provide products by one of the following:
 - 1. Genetec
- B. Description:
 - 1. System shall provide high-quality delivery and processing of IP-based video, audio, and control data using standard Ethernet-based networks.
 - 2. System shall have seamless integration of all video surveillance and control functions.
 - 3. System design shall include all necessary compression software for high-performance, dual-stream, MPEG-2/MPEG-4/h.264 video. Unit shall provide connections for all video cameras, camera PTZ control data, bidirectional audio, discreet sensor inputs, and control system outputs.
 - 4. All camera signals shall be compressed, encoded, and delivered onto the network for processing and control by the IP video-management software.
 - 5. All system interconnect cables, camera licenses, workstation programming, and other system intermediate devices shall be provided for full performance of specified system.

2.5 SIGNAL AND POWER TRANSMISSION COMPONENTS

- A. Cable: Four pair, 100 ohm, Category 6A compliant UTP. (By Section 271500)
- B. Video Surveillance Cable Connectors: Category 6A compliant. (By Section 271500)
- C. Camera Power: POE enabled network switches. (By Owner)
- D. Media Converter (Camera Fiber Connections): 10/100/1000 Media converter with Power over Ethernet. Provide OmniConverter GPoE+ by Omnitron systems or approved equal. (BA2)

PART 3 - EXECUTION

3.1 VIDEO SURVEILLANCE SYSTEM INSTALLATION

- A. Install cameras at heights noted in drawings.
- B. Set pan-and-tilt unit stops to suit final camera position and to obtain the field of view required for camera. Connect all controls and alarms, and adjust.

- C. Identify system components, wiring, cabling, and terminals according to Division 26 Section "Identification for Electrical Systems."

3.2 FIELD QUALITY CONTROL

- A. Perform tests and inspections.
 - 1. Manufacturer's Field Service: Engage a factory-authorized service representative to inspect components, assemblies, and equipment installations, including connections, and to assist in testing.
- B. Tests and Inspections:
 - 1. Inspection: Verify that units and controls are properly installed, connected, and labeled, and that interconnecting wires and terminals are identified.
 - 2. Pretesting: Align and adjust system and pretest components, wiring, and functions to verify that they comply with specified requirements. Conduct tests at varying lighting levels, including day and night scenes as applicable. Prepare video-surveillance equipment for acceptance and operational testing as follows:
 - a. Verify operation of auto-iris lenses.
 - b. Set back-focus of fixed focal length lenses. At focus set to infinity, simulate nighttime lighting conditions by using a dark glass filter of a density that produces a clear image. Adjust until image is in focus with and without the filter.
 - c. Set back-focus of zoom lenses. At focus set to infinity, simulate nighttime lighting conditions by using a dark glass filter of a density that produces a clear image. Additionally, set zoom to full wide angle and aim camera at an object **50 to 75 feet** away. Adjust until image is in focus from full wide angle to full telephoto, with the filter in place.
 - d. Set sensitivity of motion detection.
 - e. Connect and verify responses to alarms.
 - f. Verify operation of control-station equipment.
 - 3. Test Schedule: Schedule tests after pretesting has been successfully completed and system has been in normal functional operation for at least 14 days. Provide a minimum of 10 days' notice of test schedule.
 - 4. Operational Tests: Perform operational system tests to verify that system complies with Specifications. Include all modes of system operation.
- C. Video surveillance system will be considered defective if it does not pass tests and inspections.
- D. Prepare test and inspection reports.

3.3 DEMONSTRATION

- A. Train Owner's maintenance personnel to adjust, operate, and maintain video-surveillance equipment.

END OF SECTION

SECTION 28 3111

DIGITAL, ADDRESSABLE FIRE-ALARM SYSTEM

PART 1 - GENERAL

1.1 RELATED DOCUMENTS

- A. Drawings and general provisions of the Contract, including General and Supplementary Conditions and Division 01 Specification Sections, apply to this Section.

1.2 SUMMARY

- A. Section Includes:
 1. Fire-alarm control unit.
 2. Manual fire-alarm boxes.
 3. System smoke detectors.
 4. Nonsystem smoke detectors.
 5. Heat detectors.
 6. Notification appliances.
 7. Firefighters' two-way telephone communication service.
 8. Magnetic door holders.
 9. Remote annunciator.
 10. Addressable interface device.
 11. Digital alarm communicator transmitter.
 12. Radio alarm transmitter.
 13. System printer.

1.3 DEFINITIONS

- A. LED: Light-emitting diode.
- B. NICET: National Institute for Certification in Engineering Technologies.

1.4 SYSTEM DESCRIPTION

- A. Noncoded, UL-certified FMG-placarded addressable system, with automatic sensitivity control of smoke detectors and multiplexed signal transmission, dedicated to fire-alarm service only.

1.5 PERFORMANCE REQUIREMENTS

- A. Seismic Performance: Fire-alarm control unit and raceways shall withstand the effects of earthquake motions determined according to SEI/ASCE 7.
1. The term "withstand" means "the unit will remain in place without separation of any parts from the device when subjected to the seismic forces specified."

1.6 ACTION SUBMITTALS

- A. Product Data: For each type of product indicated.
- B. Shop Drawings: For fire-alarm system. Include plans, elevations, sections, details, and attachments to other work.
1. Comply with recommendations in the "Documentation" Section of the "Fundamentals of Fire Alarm Systems" Chapter in NFPA 72.
 2. Include voltage drop calculations for notification appliance circuits.
 3. Include battery-size calculations.
 4. Include performance parameters and installation details for each detector, verifying that each detector is listed for complete range of air velocity, temperature, and humidity possible when air-handling system is operating.
 5. Include plans, sections, and elevations of heating, ventilating, and air-conditioning ducts, drawn to scale and coordinating installation of duct smoke detectors and access to them. Show critical dimensions that relate to placement and support of sampling tubes, detector housing, and remote status and alarm indicators. Locate detectors according to manufacturer's written recommendations.
 6. Include voice/alarm signaling-service equipment rack or console layout, grounding schematic, amplifier power calculation, and single-line connection diagram.
 7. Include floor plans to indicate final outlet locations showing address of each addressable device. Show size and route of cable and conduits.
- C. General Submittal Requirements:
1. Submittals shall be approved by authorities having jurisdiction prior to submitting them to Architect.
 2. Shop Drawings shall be prepared by persons with the following qualifications:
 - a. Trained and certified by manufacturer in fire-alarm system design.
 - b. NICET-certified fire-alarm technician, Level III minimum.
 - c. Licensed or certified by authorities having jurisdiction.

- D. Delegated-Design Submittal: For smoke and heat detectors indicated to comply with performance requirements and design criteria, including analysis data signed and sealed by the qualified professional engineer responsible for their preparation.
 - 1. Drawings showing the location of each smoke and heat detector, ratings of each, and installation details as needed to comply with listing conditions of the detector.
 - 2. Design Calculations: Calculate requirements for selecting the spacing and sensitivity of detection, complying with NFPA 72.

1.7 INFORMATIONAL SUBMITTALS

- A. Qualification Data: For qualified Installer.
- B. Seismic Qualification Certificates: For fire-alarm control unit, accessories, and components, from manufacturer.
 - 1. Basis for Certification: Indicate whether withstand certification is based on actual test of assembled components or on calculation.
 - 2. Dimensioned Outline Drawings of Equipment Unit: Identify center of gravity and locate and describe mounting and anchorage provisions.
 - 3. Detailed description of equipment anchorage devices on which the certification is based and their installation requirements.
- C. Field quality-control reports.

1.8 CLOSEOUT SUBMITTALS

- A. Operation and Maintenance Data: For fire-alarm systems and components to include in emergency, operation, and maintenance manuals. In addition to items specified in Section 01 7823 "Operation and Maintenance Data," include the following:
 - 1. Comply with the "Records" Section of the "Inspection, Testing and Maintenance" Chapter in NFPA 72.
 - 2. Provide "Record of Completion Documents" according to NFPA 72 article "Permanent Records" in the "Records" Section of the "Inspection, Testing and Maintenance" Chapter.
 - 3. Record copy of site-specific software.
 - 4. Provide "Maintenance, Inspection and Testing Records" according to NFPA 72 article of the same name and include the following:
 - a. Frequency of testing of installed components.
 - b. Frequency of inspection of installed components.
 - c. Requirements and recommendations related to results of maintenance.
 - d. Manufacturer's user training manuals.

5. Manufacturer's required maintenance related to system warranty requirements.
 6. Abbreviated operating instructions for mounting at fire-alarm control unit.
- B. Software and Firmware Operational Documentation:
1. Software operating and upgrade manuals.
 2. Program Software Backup: On magnetic media or compact disk, complete with data files.
 3. Device address list.
 4. Printout of software application and graphic screens.

1.9 MAINTENANCE MATERIAL SUBMITTALS

- A. Furnish extra materials that match products installed and that are packaged with protective covering for storage and identified with labels describing contents.
1. Lamps for Remote Indicating Lamp Units: Quantity equal to 10 percent of amount installed, but no fewer than 1 unit.
 2. Lamps for Strobe Units: Quantity equal to 10 percent of amount installed, but no fewer than 1 unit.
 3. Smoke Detectors, Fire Detectors: Quantity equal to 10 percent of amount of each type installed, but no fewer than 1 unit of each type.
 4. Detector Bases: Quantity equal to 2 percent of amount of each type installed, but no fewer than 1 unit of each type.
 5. Keys and Tools: One extra set for access to locked and tamperproofed components.
 6. Audible and Visual Notification Appliances: One of each type installed.
 7. Fuses: Two of each type installed in the system.

1.10 QUALITY ASSURANCE

- A. Installer Qualifications: Personnel shall be trained and certified by manufacturer for installation of units required for this Project.
- B. Installer Qualifications: Installation shall be by personnel certified by NICET as fire-alarm Level II technician.
- C. Source Limitations for Fire-Alarm System and Components: Obtain fire-alarm system from single source from single manufacturer. Components shall be compatible with, and operate as, an extension of existing system.

- D. Electrical Components, Devices, and Accessories: Listed and labeled as defined in NFPA 70, by a qualified testing agency, and marked for intended location and application.
- E. NFPA Certification: Obtain certification according to NFPA 72 by an NRTL.
- F. NFPA Certification: Obtain certification according to NFPA 72 by a UL-listed alarm company.
- G. NFPA Certification: Obtain certification according to NFPA 72 in the form of a placard by an FMG-approved alarm company.
- H. NFPA Certification: Obtain certification according to NFPA 72 by the Authority Having Jurisdiction.

1.11 PROJECT CONDITIONS

- A. Interruption of Existing Fire-Alarm Service: Do not interrupt fire-alarm service to facilities occupied by Owner or others unless permitted under the following conditions and then only after arranging to provide temporary guard service according to requirements indicated:
 - 1. Notify Construction Manager no fewer than 7 days in advance of proposed interruption of fire-alarm service.
 - 2. Do not proceed with interruption of fire-alarm service without Construction Manager's written permission.

1.12 SEQUENCING AND SCHEDULING

- A. Existing Fire-Alarm Equipment: Maintain existing equipment fully operational until new equipment has been tested and accepted. As new equipment is installed, label it "NOT IN SERVICE" until it is accepted. Remove labels from new equipment when put into service and label existing fire-alarm equipment "NOT IN SERVICE" until removed from the building.
- B. Equipment Removal: After acceptance of new fire-alarm system, remove existing disconnected fire-alarm equipment and wiring.

1.13 SOFTWARE SERVICE AGREEMENT

- A. Comply with UL 864.
- B. Technical Support: Beginning with Substantial Completion, provide software support for two years.

- C. Upgrade Service: Update software to latest version at Project completion. Install and program software upgrades that become available within two years from date of Substantial Completion. Upgrading software shall include operating system. Upgrade shall include new or revised licenses for use of software.
 - 1. Provide 30 days' notice to Owner to allow scheduling and access to system and to allow Owner to upgrade computer equipment if necessary.

PART 2 - PRODUCTS

2.1 MANUFACTURERS

- A. Subject to compliance with requirements, provide product by the following:
 - 1. Notifier (Match Existing)

2.2 SYSTEMS OPERATIONAL DESCRIPTION

- A. Fire-alarm signal initiation shall be by one or more of the following devices[and systems]:
 - 1. Manual stations.
 - 2. Smoke detectors.
 - 3. Duct smoke detectors.
 - 4. Verified automatic alarm operation of smoke detectors.
 - 5. Automatic sprinkler system water flow.
 - 6. Heat detectors in elevator shaft and pit.
 - 7. Fire-extinguishing system operation.
 - 8. Fire standpipe system.
- B. Fire-alarm signal shall initiate the following actions:
 - 1. In the Clinic and Central Utility Plant (CUP), continuously operate alarm notification appliances.
 - 2. In the hospital, continuously operate chime/strobe appliances in smoke zone where alarm is initiated. Continuously operate strobe appliances throughout the hospital
 - 3. Identify alarm at fire-alarm control unit and remote annunciators.
 - 4. Transmit an alarm signal to the remote alarm receiving station.
 - 5. Unlock electric door locks in designated egress paths.
 - 6. Release fire and smoke doors held open by magnetic door holders.
 - 7. Activate voice/alarm communication system.
 - 8. Switch heating, ventilating, and air-conditioning equipment controls to fire-alarm mode.
 - 9. Activate smoke-control system (smoke management) at firefighter smoke-control system panel.

10. Activate stairwell and elevator-shaft pressurization systems.
 11. Close smoke dampers in air ducts of designated air-conditioning duct systems.
 12. Recall elevators to primary or alternate recall floors.
 13. Activate emergency lighting control.
 14. Activate emergency shutoffs for gas and fuel supplies.
 15. Record events in the system memory.
 16. Record events by the system printer.
- C. Supervisory signal initiation shall be by one or more of the following devices and actions:
1. Valve supervisory switch.
 2. Low-air-pressure switch of a dry-pipe sprinkler system.
 3. Elevator shunt-trip supervision.
 - 4.
- D. System trouble signal initiation shall be by one or more of the following devices and actions:
1. Open circuits, shorts, and grounds in designated circuits.
 2. Opening, tampering with, or removing alarm-initiating and supervisory signal-initiating devices.
 3. Loss of primary power at fire-alarm control unit.
 4. Ground or a single break in fire-alarm control unit internal circuits.
 5. Abnormal ac voltage at fire-alarm control unit.
 6. Break in standby battery circuitry.
 7. Failure of battery charging.
 8. Abnormal position of any switch at fire-alarm control unit or annunciator.
 9. Fire-pump power failure, including a dead-phase or phase-reversal condition.
 10. Low-air-pressure switch operation on a dry-pipe or preaction sprinkler system.
 - 11.
- E. System Trouble and Supervisory Signal Actions: Initiate notification appliance and annunciate at fire-alarm control unit and remote annunciators. Record the event on system printer.

2.3 FIRE-ALARM CONTROL UNIT

- A. General Requirements for Fire-Alarm Control Unit:
1. Field-programmable, microprocessor-based, modular, power-limited design with electronic modules, complying with UL 864 and listed and labeled by an NRTL.
 - a. System software and programs shall be held in flash electrically erasable programmable read-only memory

- (EEPROM), retaining the information through failure of primary and secondary power supplies.
 - b. Include a real-time clock for time annotation of events on the event recorder
 - c. Must be able to operate and monitor Pre-action systems throughout hospital
 - 2. Addressable initiation devices that communicate device identity and status.
 - a. Smoke sensors shall additionally communicate sensitivity setting and allow for adjustment of sensitivity at fire-alarm control unit.
 - b. Temperature sensors shall additionally test for and communicate the sensitivity range of the device.
 - 3. Addressable control circuits for operation of mechanical equipment.
- B. Alphanumeric Display and System Controls: Arranged for interface between human operator at fire-alarm control unit and addressable system components including annunciation and supervision. Display alarm, supervisory, and component status messages and the programming and control menu.
 - 1. Annunciator and Display: Liquid-crystal type, 3 line(s) of 80 characters, minimum.
 - 2. Keypad: Arranged to permit entry and execution of programming, display, and control commands and to indicate control commands to be entered into the system for control of smoke-detector sensitivity and other parameters.
- C. Circuits:
 - 1. Initiating Device, Notification Appliance, and Signaling Line Circuits: NFPA 72, Class A.
 - a. Initiating Device Circuits: Style D.
 - b. Notification Appliance Circuits: Style Z.
 - c. Signaling Line Circuits: Style 7.
 - d. Install no more than 50 addressable devices on each signaling line circuit.
 - 2. Serial Interfaces: Two RS-232 ports for printers.
- D. Stairwell Pressurization: Provide an output signal using an addressable relay to start the stairwell pressurization system. Signal shall remain on until alarm conditions are cleared and fire-alarm system is reset. Signal shall not stop in response to alarm acknowledge or signal silence commands.
 - 1. Pressurization starts when any alarm is received at fire-alarm control unit.
 - 2. Alarm signals from smoke detectors at pressurization air supplies have a higher priority than other alarm signals that start the system.
- E. Smoke-Alarm Verification:

1. Initiate audible and visible indication of an "alarm-verification" signal at fire-alarm control unit.
 2. Activate an NRTL-listed and -approved "alarm-verification" sequence at fire-alarm control unit and detector.
 3. Record events by the system printer.
 4. Sound general alarm if the alarm is verified.
 5. Cancel fire-alarm control unit indication and system reset if the alarm is not verified.
- F. Notification Appliance Circuit: Operation shall sound in a temporal.
- G. Elevator Recall:
1. Smoke detectors at the following locations shall initiate automatic elevator recall. Alarm-initiating devices, except those listed, shall not start elevator recall.
 - a. Elevator lobby detectors except the lobby detector on the designated floor.
 - b. Smoke detector in elevator machine room.
 - c. Smoke detectors in elevator hoistway.
 2. Elevator lobby detectors located on the designated recall floors shall be programmed to move the cars to the alternate recall floor.
 3. Water-flow alarm connected to sprinkler in an elevator shaft and elevator machine room shall shut down elevators associated with the location without time delay.
 - a. Water-flow switch associated with the sprinkler in the elevator pit may have a delay to allow elevators to move to the designated floor.
1. Door Controls: Door hold-open devices that are controlled by smoke detectors at doors in smoke barrier walls shall be connected to fire-alarm system. Review Door Hardware Schedule for sequence of operation requiring an interface with the fire alarm system, such as release upon fire alarm. Provide all fire alarm system components to accomplish the specified sequence of operation which may require components beyond those that are indicated on drawings. Provide fire alarm release at all delayed egress doors and any other doors in the path of egress that are allowed to be locked.
- H.
- I. Remote Smoke-Detector Sensitivity Adjustment: Controls shall select specific addressable smoke detectors for adjustment, display their current status and sensitivity settings, and change those settings. Allow controls to be used to program repetitive, time-scheduled, and automated changes in sensitivity of specific detector groups. Record sensitivity adjustments and sensitivity-adjustment schedule changes in system memory, and print out the final adjusted values on system printer.

- J. Transmission to Remote Alarm Receiving Station: Automatically transmit alarm, supervisory, and trouble signals to a remote alarm station.
- K. Printout of Events: On receipt of signal, print alarm, supervisory, and trouble events. Identify zone, device, and function. Include type of signal (alarm, supervisory, or trouble) and date and time of occurrence. Differentiate alarm signals from all other printed indications. Also print system reset event, including same information for device, location, date, and time. Commands initiate the printing of a list of existing alarm, supervisory, and trouble conditions in the system and a historical log of events.
- L. Primary Power: 24-V dc obtained from 120-V ac service and a power-supply module. Initiating devices, notification appliances, signaling lines, trouble signals, supervisory and digital alarm communicator transmitters shall be powered by 24-V dc source.
 - 1. Alarm current draw of entire fire-alarm system shall not exceed 80 percent of the power-supply module rating.
- M. Secondary Power: 24-V dc supply system with batteries, automatic battery charger, and automatic transfer switch.
 - 1. Batteries: Sealed, valve-regulated, recombinant lead acid.
- N. Instructions: Computer printout or typewritten instruction card mounted behind a plastic or glass cover in a stainless-steel or aluminum frame. Include interpretation and describe appropriate response for displays and signals. Briefly describe the functional operation of the system under normal, alarm, and trouble conditions.

2.4 MANUAL FIRE-ALARM BOXES

- A. General Requirements for Manual Fire-Alarm Boxes: Comply with UL 38. Boxes shall be finished in red with molded, raised-letter operating instructions in contrasting color; shall show visible indication of operation; and shall be mounted on recessed outlet box. If indicated as surface mounted, provide manufacturer's surface back box.
 - 1. Double-action mechanism requiring two actions to initiate an alarm, pull-lever type; with integral addressable module arranged to communicate manual-station status (normal, alarm, or trouble) to fire-alarm control unit.
 - 2. Station Reset: Key- or wrench-operated switch.
 - 3. Indoor Protective Shield: Factory-fabricated clear plastic enclosure hinged at the top to permit lifting for access to initiate an alarm. Lifting the cover actuates an integral battery-powered audible horn intended to discourage false-alarm operation.

4. Weatherproof Protective Shield: Factory-fabricated clear plastic enclosure hinged at the top to permit lifting for access to initiate an alarm.

2.5 SYSTEM SMOKE DETECTORS

- A. General Requirements for System Smoke Detectors:
 1. Comply with UL 268; operating at 24-V dc, nominal.
 2. Detectors shall be four-wire type.
 3. Integral Addressable Module: Arranged to communicate detector status (normal, alarm, or trouble) to fire-alarm control unit.
 4. Base Mounting: Detector and associated electronic components shall be mounted in a twist-lock module that connects to a fixed base. Provide terminals in the fixed base for connection to building wiring.
 5. Self-Restoring: Detectors do not require resetting or readjustment after actuation to restore them to normal operation.
 6. Integral Visual-Indicating Light: LED type indicating detector has operated and power-on status.
 7. Remote Control: Unless otherwise indicated, detectors shall be analog-addressable type, individually monitored at fire-alarm control unit for calibration, sensitivity, and alarm condition and individually adjustable for sensitivity by fire-alarm control unit.
 - a. Rate-of-rise temperature characteristic shall be selectable at fire-alarm control unit for **15 or 20 deg F (8 or 11 deg C)** per minute.
 - b. Fixed-temperature sensing shall be independent of rate-of-rise sensing and shall be settable at fire-alarm control unit to operate at **135 or 155 deg F (57 or 68 deg C)**.
 - c. Provide multiple levels of detection sensitivity for each sensor.
- B. Photoelectric Smoke Detectors:
 1. Detector address shall be accessible from fire-alarm control unit and shall be able to identify the detector's location within the system and its sensitivity setting.
 2. An operator at fire-alarm control unit, having the designated access level, shall be able to manually access the following for each detector:
 - a. Primary status.
 - b. Device type.
 - c. Present average value.
 - d. Present sensitivity selected.
 - e. Sensor range (normal, dirty, etc.).
- C. Ionization Smoke Detector:
 1. Detector address shall be accessible from fire-alarm control unit and shall be able to identify the detector's location within the system and its sensitivity setting.

2. An operator at fire-alarm control unit, having the designated access level, shall be able to manually access the following for each detector:
 - a. Primary status.
 - b. Device type.
 - c. Present average value.
 - d. Present sensitivity selected.
 - e. Sensor range (normal, dirty, etc.).
- D. Duct Smoke Detectors: Photoelectric type complying with UL 268A.
 1. Detector address shall be accessible from fire-alarm control unit and shall be able to identify the detector's location within the system and its sensitivity setting.
 2. An operator at fire-alarm control unit, having the designated access level, shall be able to manually access the following for each detector:
 - a. Primary status.
 - b. Device type.
 - c. Present average value.
 - d. Present sensitivity selected.
 - e. Sensor range (normal, dirty, etc.).
 3. Weatherproof Duct Housing Enclosure: NEMA 250, Type 4X; NRTL listed for use with the supplied detector.
 4. Each sensor shall have multiple levels of detection sensitivity.
 5. Sampling Tubes: Design and dimensions as recommended by manufacturer for specific duct size, air velocity, and installation conditions where applied.
 6. Relay Fan Shutdown: Rated to interrupt fan motor-control circuit.

2.6 HEAT DETECTORS

- A. General Requirements for Heat Detectors: Comply with UL 521.
- B. Heat Detector, Combination Type: Actuated by either a fixed temperature of 135 deg F (57 deg C) or a rate of rise that exceeds 15 deg F (8 deg C) per minute unless otherwise indicated.
 1. Mounting: Twist-lock base interchangeable with smoke-detector bases.
 2. Integral Addressable Module: Arranged to communicate detector status (normal, alarm, or trouble) to fire-alarm control unit.

2.7 NOTIFICATION APPLIANCES

- A. General Requirements for Notification Appliances: Individually addressed, connected to a signaling line circuit, equipped for mounting as indicated and with screw terminals for system connections.

- B. General Requirements for Notification Appliances: Connected to notification appliance signal circuits, zoned as indicated, equipped for mounting as indicated and with screw terminals for system connections.
 - 1. Combination Devices: Factory-integrated audible and visible devices in a single-mounting assembly, equipped for mounting as indicated and with screw terminals for system connections.
- C. Chimes, Low-Level Output: Vibrating type, 75-dBA minimum rated output.
- D. Chimes, High-Level Output: Vibrating type, 81-dBA minimum rated output.
- E. Horns: Electric-vibrating-polarized type, 24-V dc; with provision for housing the operating mechanism behind a grille. Comply with UL 464. Horns shall produce a sound-pressure level of 90 dBA, measured **10 feet (3 m)** from the horn, using the coded signal prescribed in UL 464 test protocol.
- F. Visible Notification Appliances: Xenon strobe lights comply with UL 1971, with clear or nominal white polycarbonate lens mounted on an aluminum faceplate. The word "FIRE" is engraved in minimum **1-inch- (25-mm-)** high letters on the lens.
 - 1. Rated Light Output:
 - a. 15/30/75/110 cd, selectable in the field.
 - 2. Mounting: Wall mounted unless otherwise indicated.
 - 3. For units with guards to prevent physical damage, light output ratings shall be determined with guards in place.
 - 4. Flashing shall be in a temporal pattern, synchronized with other units.
 - 5. Strobe Leads: Factory connected to screw terminals.
 - 6. Mounting Faceplate: Factory finished, white.

2.8 MAGNETIC DOOR HOLDERS

- A. Description: Units are equipped for wall or floor mounting as indicated and are complete with matching doorplate.
 - 1. Electromagnet: Requires no more than 3 W to develop **25-lbf (111-N)** holding force.
 - 2. Wall-Mounted Units: Flush mounted unless otherwise indicated.
 - 3. Rating: 24-V ac or dc.
 - 4. Rating: 120-V ac.
- B. Material and Finish: Match door hardware.

2.9 REMOTE ANNUNCIATOR

- A. Description: Annunciator functions shall match those of fire-alarm control unit for alarm, supervisory, and trouble indications. Manual switching functions shall match those of fire-alarm control unit, including acknowledging, silencing, resetting, and testing.
 - 1. Mounting: Flush cabinet, NEMA 250, Type 1.
- B. Display Type and Functional Performance: Alphanumeric display and LED indicating lights shall match those of fire-alarm control unit. Provide controls to acknowledge, silence, reset, and test functions for alarm, supervisory, and trouble signals.

2.10 ADDRESSABLE INTERFACE DEVICE

- A. Description: Microelectronic monitor module, NRTL listed for use in providing a system address for alarm-initiating devices for wired applications with normally open contacts.
- B. Integral Relay: Capable of providing a direct signal to elevator controller to initiate elevator recall to circuit-breaker shunt trip for power shutdown.

2.11 DIGITAL ALARM COMMUNICATOR TRANSMITTER

- A. Digital alarm communicator transmitter shall be acceptable to the remote central station and shall comply with UL 632 and be listed and labeled by an NRTL.
- B. Functional Performance: Unit shall receive an alarm, supervisory, or trouble signal from fire-alarm control unit and automatically capture two telephone line(s) and dial a preset number for a remote central station. When contact is made with central station(s), signals shall be transmitted. If service on either line is interrupted for longer than 45 seconds, transmitter shall initiate a local trouble signal and transmit the signal indicating loss of telephone line to the remote alarm receiving station over the remaining line. Transmitter shall automatically report telephone service restoration to the central station. If service is lost on both telephone lines, transmitter shall initiate the local trouble signal.
- C. Local functions and display at the digital alarm communicator transmitter shall include the following:
 - 1. Verification that both telephone lines are available.
 - 2. Programming device.
 - 3. LED display.
 - 4. Manual test report function and manual transmission clear indication.

5. Communications failure with the central station or fire-alarm control unit.
- D. Digital data transmission shall include the following:
 1. Address of the alarm-initiating device.
 2. Address of the supervisory signal.
 3. Address of the trouble-initiating device.
 4. Loss of ac supply or loss of power.
 5. Low battery.
 6. Abnormal test signal.
 7. Communication bus failure.
- E. Secondary Power: Integral rechargeable battery and automatic charger.
- F. Self-Test: Conducted automatically every 24 hours with report transmitted to central station.

2.12 SYSTEM PRINTER

- A. Printer shall be listed and labeled by an NRTL as an integral part of fire-alarm system.

2.13 DEVICE GUARDS

- A. Description: Welded wire mesh of size and shape for the manual station, smoke detector, gong, or other device requiring protection.
 1. Factory fabricated and furnished by manufacturer of device.
 2. Finish: Paint of color to match the protected device.

PART 3 - EXECUTION

3.1 EQUIPMENT INSTALLATION

- A. Comply with NFPA 72 for installation of fire-alarm equipment.
- B. Install wall-mounted equipment, with tops of cabinets not more than **72 inches (1830 mm)** above the finished floor.
 1. Comply with requirements for seismic-restraint devices specified in Section 26 0548 "Vibration and Seismic Controls for Electrical Systems."
- C. Smoke- or Heat-Detector Spacing:
 1. Comply with NFPA 72, "Smoke-Sensing Fire Detectors" Section in the "Initiating Devices" Chapter, for smoke-detector spacing.

2. Comply with NFPA 72, "Heat-Sensing Fire Detectors" Section in the "Initiating Devices" Chapter, for heat-detector spacing.
 3. Smooth ceiling spacing shall not exceed **30 feet (9 m)**.
 4. HVAC: Locate detectors not closer than **3 feet (1 m)** from air-supply diffuser or return-air opening.
 5. Lighting Fixtures: Locate detectors not closer than **12 inches (300 mm)** from any part of a lighting fixture.
- D. Duct Smoke Detectors: Comply with NFPA 72 and NFPA 90A. Install sampling tubes so they extend the full width of duct.
 - E. Heat Detectors in Elevator Shafts: Coordinate temperature rating and location with sprinkler rating and location.
 - F. Single-Station Smoke Detectors: Where more than one smoke alarm is installed within a dwelling or suite, they shall be connected so that the operation of any smoke alarm causes the alarm in all smoke alarms to sound.
 - G. Remote Status and Alarm Indicators: Install near each smoke detector and each sprinkler water-flow switch and valve-tamper switch that is not readily visible from normal viewing position.
 - H. Audible Alarm-Indicating Devices: Install not less than **6 inches (150 mm)** below the ceiling. Install bells and horns on flush-mounted back boxes with the device-operating mechanism concealed behind a grille.
 - I. Visible Alarm-Indicating Devices: Install adjacent to each alarm bell or alarm horn and at least **6 inches (150 mm)** below the ceiling.
 - J. Device Location-Indicating Lights: Locate in public space near the device they monitor.
 - K. Fire-Alarm Control Unit: Surface mounted, with tops of cabinets not more than **72 inches (1830 mm)** above the finished floor.
 - L. Annunciator: Install with top of panel not more than **72 inches (1830 mm)** above the finished floor.

3.2 WIRING INSTALLATION

- A. Wiring Method: Install wiring in metal raceway according to Division 26 Section 26 0519 Conceal raceway except in unfinished spaces and as indicated.
- B. Wiring for Grid Ceiling Mounted Devices: Install junction box at accessible location above ceiling. Use flexible metal conduit for wiring

between junction box and outlet box for ceiling mounted device. Secure flexible conduit within 12 inches of junction box.

- C. Wiring within Enclosures: Separate power-limited and non-power-limited conductors as recommended by the manufacturer. Install conductors parallel with or at right angles to sides and back of the enclosure. Bundle, lace, and train conductors to terminal points with no excess. Connect conductors that are terminated, spliced, or interrupted in any enclosure associated with the fire alarm system to terminal blocks. Mark each terminal according to the system's wiring diagrams. Make all connections with approved crimp-on terminal spade lugs, pressure-type terminal blocks, or plug connectors.
- D. Cable Taps: Use numbered terminal strips in junction, pull and outlet boxes, cabinets, or equipment enclosures where circuit connections are made.
- E. Color-Coding: Color-code fire alarm conductors differently from the normal building power wiring. Use one color-code for alarm circuit wiring and a different color-code for supervisory circuits. Color-code audible alarm-indicating circuits differently from alarm-initiating circuits. Use different colors for visible alarm-indicating devices. Paint fire alarm system junction boxes and covers red.
- F. Risers: Install at least two vertical cable risers to serve the fire alarm system. Separate risers in close proximity to each other with a minimum one-hour-rated wall, so the loss of one riser does not prevent the receipt or transmission of signal from other floors or zones.
- G. Wiring to Remote Alarm Transmitting Device: **1-inch (25-mm)** conduit between the FACP and the transmitter. Install number of conductors and electrical supervision for connecting wiring as needed to suit monitoring function.

3.3 CONNECTIONS

- A. For fire-protection systems related to doors in fire-rated walls and partitions and to doors in smoke partitions, comply with requirements in Section 08 7100 "Door Hardware." Connect hardware and devices to fire-alarm system.
 - 1. Verify that hardware and devices are NRTL listed for use with fire-alarm system in this Section before making connections.
- B. Make addressable connections with a supervised interface device to the following devices and systems. Install the interface device less than **3 feet (1 m)** from the device controlled. Make an addressable confirmation

connection when such feedback is available at the device or system being controlled.

1. Alarm-initiating connection to smoke-control system (smoke management) at firefighter smoke-control system panel.
2. Alarm-initiating connection to stairwell and elevator-shaft pressurization systems.
3. Smoke dampers in air ducts of designated air-conditioning duct systems. Provide end switches at each smoke and fire/smoke damper
4. Alarm-initiating connection to elevator recall system and components.
5. Alarm-initiating connection to activate emergency lighting control.
6. Alarm-initiating connection to activate emergency shutoffs for gas and fuel supplies.
7. Supervisory connections at valve supervisory switches.
8. Supervisory connections at low-air-pressure switch of each dry-pipe sprinkler system.
9. Supervisory connections at elevator shunt trip breaker.
10. Supervisory connections at fire-pump power failure including a dead-phase or phase-reversal condition.
11. Supervisory connections at fire-pump engine control panel.

3.4 IDENTIFICATION

- A. Identify system components, wiring, cabling, and terminals. Comply with requirements for identification specified in Section 26 0553 "Identification for Electrical Systems."
- B. Install framed instructions in a location visible from fire-alarm control unit.

3.5 GROUNDING

- A. Ground fire-alarm control unit and associated circuits; comply with IEEE 1100. Install a ground wire from main service ground to fire-alarm control unit.

3.6 FIELD QUALITY CONTROL

- A. Field tests shall be witnessed by authorities having jurisdiction.
- B. Manufacturer's Field Service: Engage a factory-authorized service representative to inspect, test, and adjust components, assemblies, and equipment installations, including connections.
- C. Perform tests and inspections.

1. Manufacturer's Field Service: Engage a factory-authorized service representative to inspect components, assemblies, and equipment installations, including connections, and to assist in testing.
- D. Tests and Inspections:
1. Visual Inspection: Conduct visual inspection prior to testing.
 - a. Inspection shall be based on completed Record Drawings and system documentation that is required by NFPA 72 in its "Completion Documents, Preparation" Table in the "Documentation" Section of the "Fundamentals of Fire Alarm Systems" Chapter.
 - b. Comply with "Visual Inspection Frequencies" Table in the "Inspection" Section of the "Inspection, Testing and Maintenance" Chapter in NFPA 72; retain the "Initial/Reacceptance" column and list only the installed components.
 2. System Testing: Comply with "Test Methods" Table in the "Testing" Section of the "Inspection, Testing and Maintenance" Chapter in NFPA 72.
 3. Test audible appliances for the public operating mode according to manufacturer's written instructions. Perform the test using a portable sound-level meter complying with Type 2 requirements in ANSI S1.4.
 4. Test audible appliances for the private operating mode according to manufacturer's written instructions.
 5. Test visible appliances for the public operating mode according to manufacturer's written instructions.
 6. Factory-authorized service representative shall prepare the "Fire Alarm System Record of Completion" in the "Documentation" Section of the "Fundamentals of Fire Alarm Systems" Chapter in NFPA 72 and the "Inspection and Testing Form" in the "Records" Section of the "Inspection, Testing and Maintenance" Chapter in NFPA 72.
- E. Reacceptance Testing: Perform reacceptance testing to verify the proper operation of added or replaced devices and appliances.
- F. Fire-alarm system will be considered defective if it does not pass tests and inspections.
- G. Prepare test and inspection reports.
- H. Maintenance Test and Inspection: Perform tests and inspections listed for weekly, monthly, quarterly, and semiannual periods. Use forms developed for initial tests and inspections.
- I. Annual Test and Inspection: One year after date of Substantial Completion, test fire-alarm system complying with visual and testing

inspection requirements in NFPA 72. Use forms developed for initial tests and inspections.

3.7 DEMONSTRATION

- A. Engage a factory-authorized service representative to train Owner's maintenance personnel to adjust, operate, and maintain fire-alarm system.

END OF SECTION 28 3111

DIVISION 31 thru 48 – NOT USED