

PROJECT MANUAL

Logan Regional Hospital Reconfiguration ASC

1350 N 500 E
Logan, UT 84341

Owner
Intermountain Healthcare

100% Construction Documents

Volume 1 of 2

Date: November 6, 2020

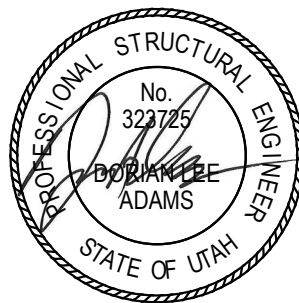
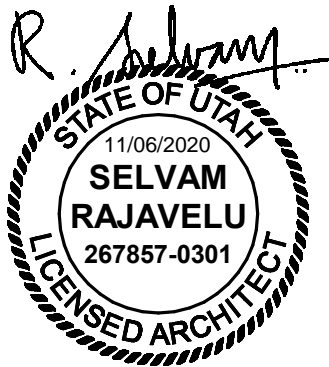

11/06/2020

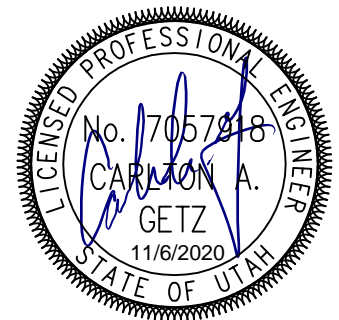

Volume 1 of 2**PROJECT MANUAL INDEX**

Title Page
Project Manual Index
Drawing Index

Bidding and Contract Requirements

Intermountain Healthcare General Conditions 2019
Application and Certificate for Payment (AIA Document G-702-1992)
Continuation of Sheet - AIA Document G703-1992
Certificate of Substantial Completion (AIA Document G704-2017)
Contractor's Affidavit of Release of Liens (AIA Document G706A-1994)

Technical Specifications**Architectural****DIVISION 1 - GENERAL REQUIREMENTS**

01 10 00	Summary
01 29 00	Payment Procedures
01 31 00	Project Management and Coordination
01 31 10	Field Engineering
01 33 00	Submittal Procedures
01 40 00	Quality Requirements
01 43 73	Schedule of Values
01 50 00	Temporary Facilities and Controls
01 60 00	Product Requirements
01 76 00	Guaranties and Warranties
01 78 23	Operation and Maintenance Data
01 78 39	Project Record Documents
01 79 00	Cleaning

DIVISION 2 – EXISTING CONDITIONS

02 41 19	Selective Demolition
----------	----------------------

DIVISION 3 - CONCRETE

03 20 00	Concrete Reinforcing
03 10 00	Concrete Forming and Accessories
03 30 00	Cast-In-Place Concrete
03 53 00	Concrete Topping

DIVISION 5 - METALS

05 05 00	Metal Fasteners
----------	-----------------

05 12 00 Structural Steel Framing
05 50 10 Miscellaneous Metal Fabrications

DIVISION 6 - WOOD AND PLASTICS

06 10 00 Rough Carpentry
06 41 23 Interior Architectural Woodwork

DIVISION 7 – THERMAL AND MOISTURE PROTECTION

07 21 00 Thermal Insulation
07 72 00 Roof Accessories
07 84 13 Firestopping
07 81 00 Applied Fireproofing
07 84 13.1 Penetration Firestopping – UL Listings
07 92 00 Joint Sealants

DIVISION 8 – DOORS AND WINDOWS

08 11 13 Hollow Metal Doors and Frames
08 14 16 Flush Wood Doors
08 31 13 Access Panels
08 33 00 Rolling Grilles
08 41 00 Aluminum Entrances and Storefronts
08 71 00 Door Hardware
08 80 00 Glazing
08 88 59 Insulating Glass Units with Integrated Blinds

DIVISION 9 - FINISHES

09 22 16 Non-Structural Metal Framing
09 22 16.1 Rated Wall Types – UL Listings
09 22 20 Acoustical Insulation
09 29 00 Gypsum Board
09 30 00 Tiling
09 50 00 Wood Panel Ceilings
09 51 00 Ceiling Suspension
09 51 13 Acoustical Panel Ceilings
09 65 19 Resilient Flooring
09 68 13 Carpet Tile
09 78 13 Interior Modular Metal Wall Panel System
09 91 23 Interior Painting

DIVISION 10 – SPECIALTIES

10 11 00 Visual Display Surfaces
10 26 00 Wall and Door Protection
10 28 00 Toilet and Bath Accessories
10 44 13 Fire Protection Cabinets and Fire Extinguishers
10 51 13 Metal Lockers

10 51 23 Plastic Laminate Clad Lockers

DIVISION 12 – FURNISHINGS

12 22 00 Curtains and Tracks
12 24 14 Roller Shades

Volume 2 of 2

PROJECT MANUAL INDEX

Title Page
Project Manual Index
Drawing Index

Mechanical

DIVISION 21 – FIRE SUPPRESSION

211000 Water Based Fire Suppression Systems

DIVISION 22 - PLUMBING

220500 Common Work Results for Plumbing
220513 Common Motor Requirements for Plumbing Equipment
220516 Expansion Fittings and Loops for Plumbing Piping
220517 Sleeves and Sleeve Seals for Plumbing Piping
220519 METERS AND GAGES FOR PLUMBING PIPING
220523 GENERAL-DUTY VALVES FOR PLUMBING PIPING
220529 HANGERS AND SUPPORTS FOR PLUMBING PIPING AND EQUIPMENT
220548 VIBRATION AND SEISMIC CONTROLS FOR PLUMBING PIPING AND EQUIPMENT
220553 Identification for Plumbing Pipes and Equipment
220700 Plumbing Insulation
221116 Domestic Water Piping
221119 Domestic Water Piping Specialties
221316 Sanitary Waste and Vent Piping
221319 Sanitary Waste Piping Specialties
224000 Plumbing Fixtures
224500 Emergency Plumbing Fixtures
226314 Medical Gas Piping
226700 Deionized Pure Water System
226710 Pure Water Piping

DIVISION 23 - HEATING, VENTILATING, AND AIR CONDITIONING

230100 MECHANICAL REQUIREMENTS
230150 Temporary Use of Equipment and Systems
230500 Common Work Results for HVAC
230513 COMMON MOTOR REQUIREMENTS FOR HVAC EQUIPMENT
230517 Sleeves and Sleeve Seals for HVAC Piping
230519 Meters and Gages for HVAC

230523	General-Duty Valves for HVAC Piping
230529	Hangers and Supports for HVAC Piping and Equipment
230548	Vibration and Seismic Controls for HVAC
230550	OPERATIONS AND MAINTENANCE OF HVAC SYSTEMS
230553	IDENTIFICATION FOR HVAC PIPING AND EQUIPMENT
230593	Testing Adjusting and Balancing for HVAC
230713	Duct Insulation
230716	HVAC Equipment Insulation
230719	HVAC Piping Insulation
230900	Building Automation System
230993	Sequences of Operation
232113	Hydronic Piping
232116	Hydronic Piping Specialties
232123	Hydronic Pumps
232213	Steam and Condensate Heating Piping
232216	Steam and Condensate Heating Piping Specialties
232513	Water Treatment for Closed-Loop Hydronic Systems
233001	COMMON DUCT REQUIREMENTS
233113	Metal Ducts
233300	Air Duct Accessories
233423	HVAC Power Ventilators
233600	Air Terminal Units
233700	Heat Exchangers
233713	DIFFUSERS, REGISTERS, AND GRILLES
237326	Custom Hospital Air Handling Units
238240	Propeller Unit Heaters

Electrical

Division 26 – Electrical

260519	Low-Voltage Electrical Power Conductors and Cables
260526	Grounding and Bonding for Electrical Systems
260529	Hangers and Supports for Electrical Systems
260533	Raceways and Boxes for Electrical Systems
260544	Sleeves and Sleeve Seals for Electrical Raceways and Cabling
260548	Vibration and Seismic Controls for Electrical Systems
260553	Identification for Electrical Systems
260800	Electrical Commissioning Requirements
260923	Lighting Control Devices
262416	Panelboards
262726	Wiring Devices
262816	Enclosed Safety Switches
262913	Enclosed Controllers
262923	Variable-Frequency Motor Controllers
265119	Led Interior Lighting

Division 27 – Communications

270000	Common General Conditions for Communications Sections Ver 06-2020
270100	Operation+Maintenance of Communication Systems Ver 06-2020_
270113	Warranty Product and System Ver 06-2020
270119	Field Testing and Reporting Ver 06-2020
270133	Shop Drawings Product Data Samples Design Records and Existing Conditions Ver 06-2020
270143	Qualifications and Required Training for Contractor and Installer Ver 06-2020
270171	Responsibility and Workmanship of Contractor Ver 06-2020
270500	Common Work Results for Communications Ver 06-2020
270526	Grounding and Bonding for Communications Systems Ver 06-2020
270528	Pathways for Communications Systems Ver 06-2020
270529	Hangers and Supports for Communications Systems Ver 06-2020
270533	Conduits and Back Boxes for Communications Systems Ver 06-2020
270536	Cable Trays for Communications Systems Ver 06-2020
270543/46	Campus Cable Routing Ver 06-2020
270553	Identification for Low-Voltage Cables And Labeling Ver 06-2020
271100	Equipment Room Fitting Ver 06-2020
271116	Cabinets, Racks, Frames, And Enclosures Ver 06-2020
271119	Termination Blocks And Patch Panels Ver 06-2020
271300	Backbone Cabling Ver 06-2020
271500	Horizontal Cabling Ver 06-2020
271513	Copper Cable Ver 06-2020
271543	Faceplates And Connectors Ver 06-2020
271619	Patch Cables Ver 06-2020
275113	Ohpage Ver 06-2020
275319	Das - Internal Cellular Paging And Antenna Systems Ver 06-2020
276001	Appendix 01 Deviation Request Process Ver 06-2020
276002	Appendix 02 Document Refresh Process Ver 06-2020
276003	Appendix 03 Data Center, Tec, Tdr Part Numbers Ver 06-2020
276004	Appendix 04 Reference Standards Ver 06-2020
276005	Appendix 05 Definitions And Abbreviations Ver 06-2020
276006	Appendix 06 Material Suppliers Ver 06-2020
276007	Appendix 07 Siemon - Certified Installation Firms Ver 06-2020
276008	Appendix 08 Lead Wall Penetrations Ver 06-2020

Division 28 – Access Control

281300	Access Control
282300	Video Surveillance
283111	Digital, Addressable Fire-Alarm System

DRAWING INDEX**GENERAL**

G001	Cover Sheet
G002	General Information
G003	General Information
G004	American National Standard Institute Requirements
G005	General Legend & Notes
G111	Code Compliance Plan Level 4 - Overall

STRUCTURAL

SE001	General Structural Notes
SE002	Legends & Abbreviations
SF104H	Budge Clinic Level Four Floor Framing Plan
SF105H	Budge Clinic Roof Framing Plan
SF543	Equipment Support Details
SF601	Schedule Sheet
SF602	Concrete Schedule and Details

ARCHITECTURAL

A140A	Floor Plan Level 4 - Overall
A141A	Demolition Floor Plan Level 4
A142A	Demolition Reflected Ceiling Plan Level 4
A143A	Floor Plan Level 4
A144A	Dimension Floor Plan Level 4
A145A	Reflected Ceiling Plan Level 4
A146A	Roof Plan - Overall
A147A	Finish Plan Level 4
A148A	Equipment Plan Level 4
A149A	Floor Pattern Plan Level 4
A251	Interior Elevations
A252	Interior Elevations
A253	Interior Elevations
A254	Interior Elevations
A255	Interior Elevations
A256	Interior Elevations
A501A	Wall Types
A502A	Wall Details
A502B	Wall Details
A503A	Ceiling Details
A504A	Door & Window Details
A505A	Cabinet Legend & Details
A505B	Cabinet Details
A505C	Cabinet Details
A506A	Details
A601A	Door & Window Schedule
A603A	Finish Schedule & Details

MECHANICAL

M001	Mechanical Symbols, Abbreviations, & General Notes
M141A	Mechanical Demolition Plan - Level 4
M143A	Mechanical New Plan - Level 4
M143A-2	Bid Alternate #1 Mechanical Plans
M143A-3	Bid Alternate #2 Mechanical Plans
M146A	Roof Plan
M201A	Mechanical Piping Demolition Plan – Lower Level
M203A	Mechanical Piping New Plan - Lower Level
M241A	Mechanical Piping Demolition Plan - Level 4
M243A	Mechanical Piping New Plan - Level 4
M501	Mechanical Details
M502	Mechanical Details
M503	Mechanical Details
M504	Mechanical Details
M505	Mechanical Details
M506	Mechanical Details
M601	Mechanical Schedules
M602	Mechanical Schedules
M603	Mechanical Schedules
M701	Zoning and Pressurization Plan - Level 4
M702	Mechanical Schematics
M703	Mechanical Schematics
M704	Mechanical Schematics

PLUMBING

P103A	Basement & Mechanical Shaft Plans
P141A	Plumbing Demolition Plan - Level 4
P143A	Plumbing New Plan- Level 4
P243A	Medical Gas New Plan -Level 4
P501	Plumbing Details
P601	Plumbing Schedules
P602	Med Gas Schedules

ELECTRICAL

EEA001	Sheet Index, Abbreviations, And General Notes
EEA100	Level 4 Overall Plan
EEA501	Electrical Details
EEA701	Typical Mounting Height Details
EEA702	Typical Labeling Details
EDA101	Level 4 Electrical Demolition Plan
EP100	Basement Power Plan
EPA101	Level 4 Power Plan
EPA102	Roof Electrical Plan
EPA601	One-Line Diagram
EPA602	One-Line Diagram
EPA603	Equipment Schedule

EPA604	Panel Schedules
EPA605	Panel Schedules
EPA606	Panel Schedules
ELA101	Level 4 Lighting Plan
ELA601	Interior Lighting Fixture Schedule
ELA602	Lighting Relay Diagrams & Schedules
ETA001	Telecom Schedule and Notes
ETA101	Level 4 Telecommunications Floor Plan
ETA501	Telecom Equipment Rack Elevations
ETA502	Telecom Details
ETA503	Telecom Details
ETA504	Telecom Equipment Rack Grounding Details
ETA601	Voice/Data Conduit Riser Diagram
EYA101	Level 4 Auxiliary Plan
EYA601	Auxiliary Schedules
FAA101	Level 4 Fire Alarm Plan
FAA601	Fire Alarm Riser

GENERAL CONDITIONS

1. General Provisions
2. Intermountain
3. A/E
4. Contractor
5. Subcontractors
6. Protection of Persons and Property
7. Modifications, Request for Information, Proposed Change Orders, and Claims Process
8. Payments and Completion
9. Tests and Inspections, Substantial and Final Completion, Uncovering, Correction of Work, and Guaranty Period
10. Insurance and Bonds
11. Miscellaneous Provisions
12. Termination or Suspension of the Contract

1. GENERAL PROVISIONS.

1.1 Basic Definitions.

“Adverse Weather”: Weather conditions that are seasonably abnormal and could not reasonably have been anticipated.

“A/E”: Generally, the licensed architect (or architecture firm) or engineer (or engineering firm) for the Project. For Contracts where the design professional is an interior designer, landscape subconsultant or other design professional, “A/E” will be deemed to refer to that design professional. If the type of design professional is not subject to professional licensure requirements, the professional must meet the prevailing standards in the State in which the Project is located for the applicable practice. When Intermountain elects not to engage an A/E for a Project, Intermountain will be considered the A/E for the Project.

“A/E’s Agreement”: Unless the context requires otherwise, the agreement executed by A/E and Intermountain for the Project.

“Addenda”: Written or graphic instruments issued before the opening of Bids, which clarify, correct or change the bidding documents or the Contract Documents.

“ASI”: A Supplemental Instruction issued by A/E to Contractor, which may result in clarifications or minor changes in the Work, but which does not affect the Contract Time or the Contract Sum.

“Bid”: The offer of the bidder submitted on the prescribed form setting forth the proposed stipulated sum for the Work to be performed.

“Bonds”: The bid bond, payment and performance bonds, and other instruments of security.

“Change Order”: A written instrument signed by Intermountain and Contractor, stating their agreement for changes to the Contract as specified on the required Intermountain change order form.

“Claim”: A dispute, demand, assertion or other matter arising in connection with the Contract or the Project submitted by Contractor or a Subcontractor at any tier in accordance with these General Conditions. A requested amendment, requested Change Order, or a Construction Change Directive (CCD) is not a Claim unless agreement cannot be reached in accordance with the procedures in these General Conditions.

“Construction Change Directive” or “CCD”: A written order signed by Intermountain, directing a change in the Work, and stating a proposed basis for adjustment, if any, in the Contract Sum or Contract Time, or both. Intermountain may by Construction Change Directive, without invalidating the Contract, order changes in the Work within the general scope of the Contract consisting of additions, deletions or other revisions; even if it may impact the Contract Sum and Contract Time.

“Contract”: The Contract Documents form the Contract for Construction.

“Contract Documents”: The documents identified as such in the Contractor’s Agreement.

“Contract Sum”: The amount stated in the Contractor’s Agreement payable by Intermountain to Contractor for performance of the Work under the Contract Documents.

“Contract Time”: The Contract Time means the period of time for Contractor’s Substantial Completion of the Work to be established as set forth in the Contractor’s Agreement.

“Contractor”: The person or entity identified as the “Contractor” in the Contractor’s Agreement.

“Contractor’s Agreement”: The “Contractor’s Agreement” means the Construction Manager/General Contractor Agreement or the General Contractor Agreement for a Stipulated Sum, as applicable, executed by Contractor and Intermountain for the Project.

“Contractor’s Direct Costs”: Actual costs incurred by the Contractor for labor, materials, equipment, insurance, bonds, Subcontractors and on-site supervision. They do not include labor costs for project managers or other off-site administration.

“Day” or “Days”: Calendar day unless otherwise specified.

“Defective”: Work that does not conform to the Contract Documents or does not meet the requirements of any inspection, referenced standard, code, test or approval referred to in the Contract Documents or by applicable law, or has been damaged.

“Director”: Intermountain’s Executive Director of Design & Construction unless the context requires otherwise. Director may include a designee selected by the Director for a specific function.

“Drawings”: The construction drawings identified in the Contractor’s Agreement.

“Intermountain”: IHC Health Services, Inc., operating through its Department of Facility Design and Construction. Unless the context requires otherwise, Intermountain is the “Owner” as that term is commonly referred to in the construction industry.

“Intermountain Representative” or “Owner’s Representative”: The person identified as such in the Contract Documents.

“Inspection” (or any derivative): A review of the Project, including but not limited to a visual review of the Work to ascertain if the Work is in accordance with the Contract Documents, including all applicable building codes and construction standards.

“Invitation to Bid”: Intermountain’s solicitation or request to a contractor to provide a Bid.

“Modification”: (1) Change Order, (2) Construction Change Directive, or (3) ASI.

“Notice to Proceed”: A document prepared by Intermountain authorizing Contractor to commence Work on the Project. It is deemed issued upon delivery to Contractor or upon being sent by Intermountain to the address for Contractor’s specified in the Bid or Proposal.

“Partial Use”: Placing a portion of the Work in service for the purpose for which it is intended (or a related purpose) before reaching Substantial Completion for all the Work. Partial Use does not constitute “substantial completion.”

“Product Data”: Illustrations, standard schedules, performance charts, instructions, brochures, diagrams and other information furnished by Contractor to illustrate materials or equipment for some portion of the Work.

“Project”: Generally identified and defined in the Contractor’s Agreement and Contract Documents. It includes all of the Work to be performed under the Contract Documents.

“Project Manual” (for construction): The volume of assembled Specifications for the Work, which may include the bidding/proposal requirements, sample forms, and General or Supplementary Conditions of the Contract.

“Proposal”: A/E’s or Contractor’s response to Intermountain’s Request for Proposal.

“Proposal Request” or **“PR”**: A written request submitted to Contractor for a proposal to resolve an issue as part of the Change Order or Contract Modification process.

“Proposed Change Order” or **“PCO”**: An informal request by Contractor to Intermountain Representative to commence the Contract Modification Process. It will not be considered a “Claim.” The PCO may be related to any potential or actual delay, disruption, unforeseen condition or materials or any other matter for which Contractor intends to seek additional monies or time.

“Request for Information” or **“RFI”**: A request by Contractor to A/E for information, direction or clarification regarding the Contract Documents, plans or specifications.

“Request for Proposal” or **“RFP”**: Intermountain’s solicitation for Contractor Proposals.

“Sales Tax” and/or **“Use Tax”**: Unless the context requires otherwise, the sales tax or use tax collected or to be collected by any Federal or State Tax Commission as well as by any special district, local government or political subdivision.

“Samples”: Physical examples, which illustrate materials, equipment or workmanship and establish standards by which the Work will be judged.

“Shop Drawings”: Drawings, diagrams, schedules and other data specially prepared for the Work by Contractor or a Subcontractor, Sub-subcontractor, manufacturer, supplier or distributor to illustrate some portion of the Work.

“Specifications”: The portion of the Contract Documents consisting of the written requirements for materials, equipment, construction systems, standards, installation and workmanship for the Work, and for performance of related systems and services.

“Subcontractor”: Any person or entity that has a direct contract with Contractor, including any trade contractor or specialty contractor, and/or with any other Subcontractor at any tier to provide labor or materials for the Work.

“Subcontractor’s Direct Costs”: Actual costs incurred by a Subcontractor for labor, materials, equipment, insurance, bonds, lower-tier Subcontractors and supervision.

“Substantial Completion”: Completion of the Work or designated portion thereof in accordance with the Contract Documents to a point sufficient to allow Intermountain to occupy and use the Work for its intended purposes, including without limitation all systems shall be fully functional and operate as designed, and the A/E’s certification that Contractor has achieved Substantial Completion of the Work. The date of Substantial Completion is the date certified as such by the A/E in accordance with the Contract Documents.

“Work”: All labor, materials, tools, equipment, construction and services required by the Contract Documents.

1.2 Correlation and Intent of Contract Documents.

- 1.2.1 The intent of the Contract Documents is to require Contractor to provide all labor, materials, equipment, construction, and services necessary for the proper execution and completion of the Work. The Contract Documents are complementary and what is required by any one will be as binding as if required by all. Contractor will perform the Work in accordance with the requirements expressly set forth in or reasonably inferable from the Contract Documents.
- 1.2.2 The organization of the Contract Documents is not intended to control Contractor in dividing the Work among Subcontractors or to establish the extent of the Work to be performed by any trade.
- 1.2.3 Words used in the Contract Documents that have well known technical or trade meanings are used therein in accordance with such recognized meanings.

1.2.4 In the interest of brevity, the Contract Documents may omit modifying words such as "all" and "any" and articles such as "the" and "an," but the fact that a modifier or an article is absent from one statement and appears in another is not intended to affect the interpretation of either statement.

1.3 Ownership and Use of Contract Documents. The Drawings, the Project Manual, and copies thereof are the property of Intermountain. Contractor will not use these documents on any other project. Contractor may retain one copy of the Drawings and the Project Manual as a contract record set and will return or destroy all remaining copies following final completion of the Work.

1.4 Public Statements Regarding Project. Contractor will not make any statements or provide any information to the media about the Project without the prior written consent of Intermountain. If Contractor receives any requests for information from media, Contractor will refer such requests to Intermountain.

1.5 Ownership and Use of Renderings and Photographs. Renderings representing the Work are the property of Intermountain. All photographs of the Work, whether taken during performance of the Work or at completion, are the property of Intermountain. Intermountain reserves all rights including copyrights to renderings and photographs of the Work. No renderings or photographs will be used or distributed without written consent of Intermountain.

1.6 Confidentiality / Property Rights.

1.6.1 All Drawings, Specifications and other documents prepared by A/E are and will remain the property of Intermountain, and Intermountain will retain all common law, statutory and other reserved rights with respect thereto. These documents were prepared and are intended for use as an integrated set for the Project which is the subject of the Contractor's Agreement and constitute works made for hire. Contractor will not modify or use Contract Documents on any other project without the prior written consent of Intermountain. Intermountain may withhold its consent in its absolute discretion. Any non-permissive use or modification, by Contractor, Contractor's Subcontractors at any tier or anyone for whose acts Contractor is liable, will be at Contractor's sole risk. Contractor will hold harmless and indemnify Intermountain from and against any and all claims, actions, suits, costs, damages, loss, expenses and attorney fees arising out of such non-permissive use or modification by Contractor. Contractor and Subcontractors are granted a limited license to use and reproduce applicable portions of the Drawings, Specifications and other documents prepared by A/E or Intermountain appropriate to and for use in the execution of their Work under the Contract Documents. All copies made under this license will bear the statutory copyright notice, if any, shown on the Drawings, Specifications and other documents prepared by A/E or Intermountain. Submittals or distributions necessary to meet official regulatory requirements or for other purposes relating to completion of the Project are not to be construed as a publication in derogation of Intermountain's copyright or other reserved rights.

1.6.2 In addition, Contractor will ensure that Contractor, Subcontractors, and the employees, agents and representatives of Contractor and its Subcontractors maintain in strict confidence, and will use and disclose only as authorized by Intermountain all Confidential Information of Intermountain that Contractor receives in connection with the performance of the Contract. Notwithstanding the foregoing, Contractor may use and disclose any information to the extent required by an order of any court or authority having jurisdiction, but only after it has notified Intermountain and Intermountain has had an opportunity to obtain reasonable protection for such information in connection with such disclosure. For purposes of the Contract, "Confidential Information" means:

1.6.3 The name or address of any affiliate, customer or contractor of Intermountain or any information concerning the transactions of any such person with Intermountain;

1.6.4 Any information relating to contracts, agreements, business plans, budgets or other financial information of Intermountain to the extent such information has not been made available to the public by Intermountain; and

- 1.6.5 Any other information that is marked or noted as confidential by Intermountain at the time of its disclosure.

1.7 Comply with Intellectual Property Rights of Others. Contractor represents and warrants that no Work (with its means, methods, goods, and services attendant thereto), provided to Intermountain will infringe or violate any right of any third party and that Intermountain may use and exploit such Work, means, methods, goods, and services without liability or obligation to any person or entity (specifically and without limitation, such Work, means, methods, goods, and services will not violate rights under any patent, copyright, trademark, or other intellectual property right or application for the same).

2. INTERMOUNTAIN.

2.1 Information and Services Required of Intermountain.

- 2.1.1 Intermountain Representative. Intermountain will designate an Intermountain Representative authorized to act in Intermountain's behalf with respect to the Project. Intermountain or such authorized representative will furnish to Contractor information or services Intermountain is required to furnish under the Contract Documents within a reasonable time in order to avoid a delay in the orderly and sequential progress of the Work.
- 2.1.2 Specialists and Inspectors. Intermountain reserves the right (but without obligation to provide building inspection services. This may include 'routine' and 'special' inspections. Intermountain may assign an inspector or specialist to note deviations from, or necessary adjustments to, the Contract Documents or to report deficiencies or defects in the Work. The inspector or specialist's activities in no way relieve Contractor of the responsibilities set forth in the Contract Documents.
- 2.1.3 Inspections. Intermountain and its representatives will have the right to inspect any portion of the Work wherever located at any time.
- 2.1.4 Surveys and Legal Description. Intermountain will furnish surveys describing the property lines and benchmarks for grading. Contractor will review this information, including the surveys and any provided geotechnical studies, and compare such information with observable physical conditions and the Contract Documents.
- 2.1.5 Prompt Information and Services. Upon receipt of a written request from Contractor, Intermountain will furnish information or services under Intermountain's control with reasonable promptness to avoid delay in the orderly progress of the Work.
- 2.1.6 Copies of Drawings and Project Manuals (for Construction). Unless otherwise provided in the Contract Documents, Contractor will be furnished electronic copies of Drawings and Project Manuals for Contractor's use in connection with the execution of the Work for the Project. Contractor will be responsible for making any further needed copies of the Construction Documents, subject to the copyright requirements.

2.2 Construction by Intermountain or By Separate Contractors.

- 2.2.1 Intermountain's Right to Perform Construction and to Award Separate Contracts.
- a. *In General.* Intermountain reserves the right to perform construction or operations related to the Project with Intermountain's own forces, and to award separate contracts related to the Project or other construction or operations on the site.
 - b. *Coordination and Revisions.* Intermountain will provide for coordination of the activities of Intermountain's own forces and of each separate contractor with the Work of Contractor, who will cooperate with them. Contractor will promptly notify in writing if any such independent action will in any way compromise Contractor's ability to meet Contractor's responsibilities under the Contract. Contractor will participate with other separate contractors and Intermountain in reviewing their construction schedules when directed to do so. Contractor will make any revisions to the construction schedule and Contract Sum deemed necessary after a

joint review and agreement by Intermountain. The construction schedules will then constitute the schedules to be used by Contractor, separate contractors and Intermountain until subsequently revised.

2.2.2 Mutual Responsibility.

- a. *Contractor Coordination.* Contractor will afford Intermountain and separate contractor(s) a reasonable opportunity for delivery and storage of their materials and equipment and performance of their activities and will connect and coordinate Contractor's construction and operations with theirs where applicable.
- b. *Reporting Problems to Intermountain.* If part of Contractor's Work depends on work by Intermountain or a separate contractor, Contractor will, before proceeding with that portion of the Work, inspect and promptly report in writing to Intermountain apparent discrepancies or defects in workmanship that would render it unsuitable for proper execution, performance, or results. Failure of Contractor to so inspect and make this report will constitute an acceptance and acknowledgment that Intermountain's or separate contractors completed or partially completed construction is fit and proper to receive Contractor's Work, except as to defects in workmanship not then reasonably discoverable.
- c. *Costs.* Costs caused by delays or by improperly timed activities or Defective construction will be borne by the responsible party in accordance with the procedures and provisions of the Contract Documents.
- d. *Contractor Remedial Work.* Contractor will promptly remedy damage caused by Contractor or any Subcontractor to completed or partially completed work of Intermountain or of separate contractors or to the property of Intermountain or separate contractors and subcontractors.
- e. *Intermountain's Right to Clean Up.* If a dispute arises among Contractor and separate contractors as to the responsibility under their separate contracts for maintaining the Project free from waste materials and rubbish, Intermountain may clean the Project, allocate the cost among those responsible as Intermountain and A/E determine to be just, and withhold such cost from any amounts due or to become due to Contractor.

3. A/E.

3.1 A/E's Administration of the Contract.

- 3.1.1 In General. A/E assists Intermountain with the administration of the Contract as described in the Contract Documents.
- 3.1.2 Site Visits. Site visits or inspections by A/E, Intermountain or any Intermountain representative will in no way limit or affect Contractor's responsibility to comply with all the requirements and the overall design concept of the Contract Documents as well as all applicable laws, statutes, ordinances, resolutions, codes, rules, regulations, orders and decrees. A/E will promptly submit to Intermountain a written report subsequent to each site visit.
- 3.1.3 Communications Facilitating Contract Administration. Except as authorized by Intermountain or as otherwise provided in the Contract Documents, including these General Conditions, A/E and Contractor will communicate through the Intermountain Representative on issues regarding the timing of the Work, cost of the Work, and scope of the Work. Contractor will comply with communication policies agreed upon at any pre-construction meeting with Intermountain. Communications by and with A/E sub-consultants will be through A/E. Communications by and with Subcontractors will be through Contractor. Communications by and with separate contractors will be through Intermountain.
- 3.1.4 A/E May Reject Work, Order Inspection, Tests. A/E will have the authority to reject Work which, based upon A/E's knowledge or what may be reasonably inferred from A/E's site observations and review of data, does not conform to the Contract Documents or is damaged or rendered unsuitable.

Whenever A/E considers it necessary or advisable for implementation of the intent of the Contract Documents, A/E will have the authority to require additional inspections or testing of the Work in accordance with the provisions of the Contract Documents, whether or not such Work is fabricated, installed or completed. However, neither this authority of A/E nor a decision made in good faith either to exercise or not to exercise such authority will give rise to a duty or responsibility of A/E to Contractor, Subcontractors, their agents or employees or other persons performing portions of the Work, including separate contractors.

3.1.5 A/E Review Contractor's Submittals.

- a. Contractor will submit shop drawings, product data, and samples and other submittals required by the Contract Documents to A/E as required by the approved submittal schedule.
- b. A/E will review and approve or take other appropriate action upon Contractor's submittals such as Shop Drawings, Product Data and Samples, but only for the purpose of checking for conformance with the information and design concepts expressed in the Contract Documents. A/E action taken on a submittal will not constitute a Modification of the Contract.
- c. A/E's action will be taken no later than fifteen (15) Days following A/E's receipt of the submittal, unless agreed to otherwise by Contractor and Intermountain.
- d. Review of such submittals is not conducted for the purpose of determining the accuracy and completeness of other details such as dimensions and quantities or for substantiating instructions for installation or performance of equipment or systems, all of which remain the responsibility of Contractor as required by the Contract Documents.
- e. A/E's review of Contractor's submittals will not relieve Contractor of the obligations under the Contract Documents.
- f. A/E's review will not constitute approval of safety precautions or, unless otherwise specifically stated by A/E, of any construction means, methods, techniques, sequences or procedures.
- g. A/E's approval of a specific item will not indicate approval of an assembly of which the item is a component.
- h. When professional certification of performance characteristics of materials, systems or equipment is required by the Contract Documents, A/E will be entitled to rely upon such certifications to establish that the materials systems or equipment will meet the performance criteria required by the Contract Documents.

3.2 Ownership and Use of A/E's Drawings, Specifications and Other Documents. All Drawings, Specifications and other documents prepared by A/E are and will remain the property of Intermountain, and Intermountain will retain all common law, statutory and other reserved rights with respect thereto. These documents were prepared and are intended for use as an integrated set for the Project which is the subject of the Contractor's Agreement and constitute works made for hire. Contractor will not modify or use Contract Documents on any other project without the prior written consent of Intermountain. Intermountain may withhold its consent in its absolute discretion. Any non-permissive use or modification, by Contractor, Contractor's Subcontractors at any tier or anyone for whose acts Contractor is liable, will be at Contractor's sole risk. Contractor will hold harmless and indemnify Intermountain from and against any and all claims, actions, suits, costs, damages, loss, expenses and attorney fees arising out of such non-permissive use or modification by Contractor. Contractor and Subcontractors are granted a limited license to use and reproduce applicable portions of the Drawings, Specifications and other documents prepared by A/E or Intermountain appropriate to and for use in the execution of their Work under the Contract Documents. All copies made under this license will bear the statutory copyright notice, if any, shown on the Drawings, Specifications and other documents prepared by A/E or Intermountain. Submittals or distributions necessary to meet official regulatory requirements or for other purposes relating to completion of the Project are not to be construed as a publication in derogation of Intermountain's copyright or other reserved rights.

4. CONTRACTOR. Contractor's duties include the professional services of a business, administrative and management consultant to Intermountain; including all budget, scheduling, quality, safety and all other services related to assuring compliance with the Contract Documents.

4.1 Review of Contract Documents and Field Conditions by Contractor. By executing the Contractor's Agreement, Contractor represents that it has visited the Project site, familiarized itself with the local conditions under which the Work is to be performed, and correlated its own observations with the requirements of the Contract Documents.

4.1.1 Reviewing Contract Documents, Information, Reporting Errors, Inconsistencies or Omissions.

- a. Contractor will carefully study and compare the Contract Documents with each other and with information available relating to the Project or furnished by Intermountain before commencing and during performance of each portion of the Work and will at once report to Intermountain and A/E any errors, inconsistencies or omissions it discovers. If Contractor performs any construction activity without such notice to Intermountain and A/E and before the resolution of the error, inconsistency or omission, Contractor will assume responsibility for such performance and will bear the attributable costs for correction.
- b. Contractor will give Intermountain and/or A/E notice of any additional drawings, specifications, or instructions required to define the Work in greater detail, or to permit the proper progress of the Work, sufficiently in advance of the need for information so as not to delay the Work.
- c. It is not Contractor's responsibility to ascertain that the Contract Documents are in accordance with requirements of applicable laws, statutes, ordinances, building codes, rules and regulations. However, if Contractor observes that portions of the Contract Documents are at variance with those requirements, Contractor will immediately notify Intermountain and/or A/E in writing. Contractor will not proceed unless Intermountain and/or A/E effects Modifications to the Contract Documents required for compliance with such requirements. Contractor will be fully responsible for any work knowingly performed contrary to such requirements and will fully indemnify Intermountain against loss and bear all costs and penalties arising therefrom.

4.1.2 Field Conditions.

- a. Contractor will take field measurements and verify field conditions and will carefully compare such field measurements and conditions and other information known to Contractor, or information which a Contractor of ordinary skill and expertise for the type of Work involved would have known, before commencing activities. Errors, inconsistencies or omissions discovered will be reported to Intermountain and A/E at once. If Contractor performs any construction activity without such notice to Intermountain and A/E and before the resolution of the error, inconsistency or omission, Contractor will not be entitled to any compensation for additional costs attributable to correction or otherwise to Contractor resulting from field measurements or conditions different from those anticipated by Contractor which would have been avoided had Contractor taken field measurements and verified field conditions before ordering the materials or commencing construction activities.
- b. If site conditions indicated in the Contract Documents or other information provided by Intermountain or A/E to Contractor differ materially from those Contractor encounters in performance of the Work, Contractor will immediately notify Intermountain and/or A/E in writing of such differing site conditions.

4.1.3 Perform in Accordance with Contract Documents and Submittals. Contractor will perform the Work in accordance with the Contract Documents and submittals approved in accordance with the Contract Documents. Should Contractor or any of its Subcontractors become aware of any question regarding the meaning or intent of any part of the Contract Documents before commencing that portion of the Work about which there is a question, Contractor will request an interpretation or clarification from Intermountain and/or A/E before proceeding. Contractor proceeds at its own risk if it proceeds with

the Work without first making such a request and receiving an interpretation or clarification from Intermountain and/or A/E.

- 4.1.4 Performance to Produce the Complete System and Intended Results. Performance by Contractor will be required to the extent consistent with the Contract Documents and reasonably inferable from the Contract Documents as being necessary to allow the system to function within its intended use.
- 4.1.5 Intent and Hierarchy. The Contract Documents should be read as a whole and wherever possible, the provisions should be construed in order that all provisions are operable. The intent of the Contract Documents is to include all items necessary for the proper execution and completion of the Work by Contractor. The Contract Documents are complimentary, and what is required by one Document or provisions thereof will be as binding as if required by all the Documents or provisions thereof. In case of an irreconcilable conflict between provisions within a Contract Document or between Contract Documents, the following priorities will govern as listed below:
- a. A particular Modification will govern over all Contract Document provisions or Modifications issued before this particular Modification.
 - b. A particular Addendum will govern over all other Contract Document provisions issued before this particular Addendum. Subsequent Addenda will govern over all prior Addenda.
 - c. The Supplementary Conditions will govern over the General Conditions.
 - d. The Agreement and these General Conditions will govern over all other Contract Documents except for the Supplementary Conditions, Addenda, Modifications.
 - e. The drawings and specifications will not govern over any of the documents listed above. The specifications take precedence over the drawings.
 - f. Within the Drawings, larger scale drawings take precedence over smaller scale drawings, figured dimensions over scaled dimensions, and noted materials over graphic indications.
 - g. In case of a conflict or ambiguity within the same level of hierarchy of described documents, Intermountain reserves the right to select the most stringent requirement unless the preponderance of the contract indicates the less stringent requirement.
- 4.1.6 Dividing Work and Contractor Representation. Organization of the specifications into divisions, sections and articles, and arrangement of Drawings, will not control Contractor in dividing the Work among Subcontractors or in establishing the extent of Work to be performed by any trade. Contractor represents that the Subcontractors, Sub-subcontractors, manufacturers and suppliers engaged or to be engaged by it are and will be familiar with the requirements for performance by them of their obligations. Where the Contract Documents require Contractor to provide professional services for architecture or engineering, Contractor will cause such services to be performed by appropriately licensed professionals.
- 4.1.7 Planning and Priority. Contractor will plan and schedule its work to facilitate the Project and will maintain a work schedule to place proper priority to sequence work to complete the project timely.
- 4.1.8 Prior to Contractor taking control over any area in any existing facility or on any project site, Contractor will provide prior written notice to Intermountain with sufficient time (no less than 30 Days) to allow Intermountain's Asset Recovery Team to remove, secure, and otherwise address existing materials, furniture, fixtures, equipment, and other assets located thereon.

4.2 Supervision and Construction Procedures.

- 4.2.1 Supervision and Control.
- a. Contractor will utilize its best skill, efforts, and judgment to provide efficient business administration and supervision, to furnish at all times an adequate supply of workers and materials, and to perform the Work in an expeditious and economical manner consistent with

the interests of Intermountain.

- b. Contractor will supervise and direct the Work. Contractor will be solely responsible for all construction means, methods, techniques, sequences and procedures and for coordinating all portions of the Work.
- c. All loss, damage, liability, or cost of correcting Defective work arising from the use of any construction means, methods, techniques, sequences or procedures will be borne by Contractor, notwithstanding that such construction means, methods, techniques, sequences or procedures are referred to, indicated or implied by the Contract Documents, unless Contractor has given timely notice to Intermountain and A/E in writing that such means, methods, techniques, sequences or procedures are not safe or suitable, and Intermountain has then instructed Contractor in writing to proceed at Intermountain's risk.

4.2.2 Responsibility. Contractor will be responsible to Intermountain for acts and omissions of Contractor's employees, Subcontractors, and their agents and employees, and other persons performing portions of the Work under a contract with Contractor or on behalf of Contractor.

4.2.3 Not Relieved of Obligations. Contractor will not be relieved of obligations to perform the Work in accordance with the Contract Documents either by activities or duties of Intermountain or its agents in Intermountain's administration of the Contract, or by tests, inspections or approvals by Intermountain, A/E, or their consultants, or as required or performed by persons other than Contractor or for those that Contractor is liable.

4.2.4 Inspections and Approvals.

- a. Contractor is responsible for requesting inspections for various stages and portions of the Work required under the Contract Documents in a timely manner.
- b. Contractor will be responsible for inspection of portions of the Work already completed to determine that such portions are in proper condition to receive subsequent portions of the Work.
- c. If any of the Work is required to be inspected or approved by the terms of the Contract Documents by any public authority, Contractor will timely request such inspection or approval to be performed in accordance with Article 9. Except as provided in Article 9, work will not proceed without any required inspection and the associated authorization to proceed. Contractor will promptly notify Intermountain if the inspector fails to appear at the site.

4.3 Labor and Materials.

4.3.1 Payment by Contractor. Except to the extent it is otherwise stated in the Contract Documents, Contractor will provide and pay for labor, materials, equipment, tools, construction equipment and machinery, water, heat, utilities, transportation, and other facilities, supplies, consumables and services necessary for the proper execution and completion of the Work, whether temporary or permanent and whether or not incorporated or to be incorporated in the Work.

4.3.2 Discipline and Competence. Contractor will enforce strict discipline and good order among Contractor's employees, Subcontractors, agents, representatives and other persons performing under the Contract Documents. Contractor will not permit employment of unfit persons or persons not skilled in tasks assigned to them.

4.3.3 Phased Construction / Accommodations for Facilities to Stay Operational. Contractor and all Subcontractors will direct and perform the Work, phase and coordinate all construction and related activities and timing, in a manner to preserve ongoing patient care and safety to all and to accommodate in every instance Intermountain's ongoing business operations such that facilities stay fully functioning and operational at all times.

4.4 Taxes and Other Payments to Government. Intermountain will pay all taxes and assessments on the real property comprising the Project site. Contractor will pay all applicable sales, consumer, use, payroll, workers

compensation, unemployment, old age pension, surtax, and employment-related and similar taxes related to performance of the Work or portions thereof provided by Contractor which are legally enacted when bids are received or negotiations concluded, whether or not yet effective or merely scheduled to go into effect, and will comply with the laws and regulations regarding the payment of Sales and/or Use Tax and any applicable exemptions.

4.5 Permits, Fees, Notices, Labor and Materials.

4.5.1 Permits and Fees.

- a. Intermountain will obtain and pay for all zoning and use permits and permanent easements necessary for completion of the Work.
- b. Contractor will obtain and pay for the building permit, and all other permits, governmental fees, licenses and inspections necessary for the proper execution and completion of the Work.
- c. Contractor will secure any certificates of inspection and of occupancy required by authorities having jurisdiction over the Work. Contractor will deliver these certificates to A/E before issuance of the Certificate of Substantial Completion by A/E.

4.5.2 Compliance with Law, Public Authorities, Notices. Contractor will comply with all applicable federal, state and local laws, statutes, ordinances, resolutions, rules, regulations, codes, and lawful orders of public authorities.

4.5.3 Correlation of Contract Documents and Enactments.

- a. It is not Contractor's responsibility to ascertain that the Contract Documents are in accordance with applicable laws, statutes, ordinances, resolutions, building codes, and rules and regulations. Notwithstanding this, if Contractor observes, or if such is readily observable to a Contractor of ordinary skill and expertise for the type of Work involved, that a portion of the Contract Documents is at variance therewith, Contractor will promptly notify A/E and Intermountain in writing, and necessary changes will be accomplished by appropriate Modification.
- b. Contractor will coordinate and supervise the work performed by Subcontractors so that the Work is carried out without conflict between trades and so that no trade, at any time, causes delay to the general progress of the Work. Contractor and all Subcontractors will at all times afford each trade, any separate contractor, or Intermountain, reasonable opportunity for the installation of Work and the storage of materials.
- c. Contractor is fully responsible for the Project and all materials and work connected therewith until Intermountain has accepted the Work in writing. Contractor will replace or repair at its own expense any materials or work damaged or stolen, regardless of whether it has received payment for such work or materials from Intermountain.
- d. Contractor will remedy all damage or loss to any property caused in whole or in part by Contractor, any Subcontractor, or by anyone for whose acts any of them may be liable.
- e. Intermountain may elect to purchase materials required for the Work. In that event, Contractor will comply with the procedures set forth in the Contract Documents relating to such materials.

4.5.4 Failure to Give Notice. If Contractor, or any Subcontractor thereof performs Work without complying with the requirements of this Article 4.5 hereinabove, Contractor will assume appropriate responsibility for such Work and will bear the appropriate amount of the attributable costs.

4.5.5 Intermountain-Purchased Materials and Equipment.

- a. In addition to Contractor's other obligations with respect to separate Intermountain provided work or materials, Contractor's obligations and duties with respect to Intermountain-purchased materials, equipment, and work include:

- (i) Scheduling: The Contractor shall furnish Intermountain with a schedule of dates on which the Contractor requires delivery of Intermountain-purchased materials. Intermountain will arrange for the materials to be delivered to the construction site or picked up by Contractor on or before the specified dates. If delivery or pick up dates are changed, rescheduled, or otherwise varied from the original schedule, the Contractor shall notify Intermountain in writing of delivery or pick up date rescheduling and the Contractor shall coordinate the delivery or pick up of the Intermountain-purchased materials or equipment directly with the supplier.
- (ii) Equipment / Vehicles: If Intermountain buys equipment or vehicles for Contractor's use on the Project, Contractor will (in addition to all other obligations herein relative to such equipment or vehicles) be fully and solely responsible for such equipment and vehicles as well as the use and use consequences thereof for any and all purposes (including without limitation to protect, secure, inspect, upkeep and make repairs, and insure such equipment and vehicles as well as to monitor, guide, direct, oversee, protect, and control the use and use consequences of such equipment and vehicles) until completion of the Project and Contractor's return of such equipment and/or vehicles to Intermountain.
- (iii) Pre-Installation Inspection: The Contractor shall be responsible for receiving, inspecting and storing all Intermountain- purchased materials and equipment until the materials or equipment are needed for installation or use by the Contractor. Regardless of any inspection performed by Intermountain of the Intermountain-purchased materials or equipment, the Contractor shall be responsible for inspecting the Intermountain-purchased materials and equipment to determine suitability, quality and conformance with specifications before installation or use or at such other times as the Contractor may desire in order to avoid interruptions and delays in the progress of the Project. The Contractor shall reject any material which does not meet specifications or which appears to have any defect which may make the material unsuitable for use in the Project. The Contractor shall notify Intermountain and the manufacturer or supplier of all defects and assist Intermountain in arranging for the repair, replacement or correction of the defective condition. The Contractor shall not be entitled to an extension of any deadline or completion date which results from failure to discover defects which the Contractor should have discovered through an inspection.
- (iv) Defective Materials: The Contractor acknowledges that use of improper or defective material may result in costs and damages to Intermountain in excess of the value of the materials; that after use in the Project it may be difficult or impossible to inspect the material to determine the cause of any failure; and that in the event of the failure of material there may be a question as to the cause of the failure. Because the Contractor's employees will be the last to handle and inspect material prior to incorporation into the Project, the Contractor will be liable to Intermountain for damages resulting from failure of Intermountain- purchased materials during the Contractor's warranty period specified herein from any cause whatsoever unless the Contractor provides clear and convincing proof that (1) the entire loss from a failure is covered by a valid manufacturer's or supplier's warranty, or (2) the Contractor could not have prevented the failure by complying with the requirements of this Section concerning Intermountain-purchased materials.
- (v) Claims: The Contractor agrees to assist Intermountain to present claims to manufacturers and suppliers for defects in Intermountain-purchased materials. Where there is any question as to the division of liability between the Contractor and a manufacturer or vendor, the Contractor shall provide all relevant information in the Contractor's possession which may aid Intermountain in determining the division of responsibility. Intermountain shall have final approval of any proposed adjustment or settlement of warranty claims.

- (vi) Implied Warranties: The benefit of contractual and implied warranties with respect to Intermountain-purchased materials and equipment shall run to Intermountain and not to the Contractor.
 - (vii) Unloading: Except as otherwise provided herein, the Contractor shall be responsible for unloading all Intermountain- purchased materials and equipment and for verifying delivery amounts to Intermountain.
 - (viii) Custody and Security: The Contractor shall secure and protect Intermountain-purchased materials and equipment from loss, deterioration, damage, theft, vandalism or destruction. If any Intermountain-purchased materials or equipment are damaged, stolen, or lost, Contractor will timely replace such at Contractor's sole cost and expense. In such event, Contractor will not be entitled to any modification in Contract Time or Contract Sum.
 - (ix) Reports: At Intermountain's request, the Contractor shall furnish reports to the Intermountain Representative demonstrating the Contractor's compliance with this Section.
 - (x) Retained Ownership: All materials and equipment purchased by Intermountain which remain after completion of the Project shall be the property of Intermountain. If Intermountain does not wish to retain or dispose of surplus Intermountain-purchased materials or equipment, the Contractor shall remove and dispose of them.
- b. None of the foregoing duties of the Contractor with respect to Intermountain-purchased materials shall prevent Intermountain from exercising any prerogative of ownership of the materials or equipment.

4.6 Superintendent. Contractor will employ a competent superintendent and necessary assistants who will be in attendance at the Project site at all times during performance of the Work. The superintendent will represent Contractor, and communications given to the superintendent will be as binding as if given to Contractor. Important communications will be confirmed in writing. Other communications will be similarly confirmed on written request in each case.

4.7 Time and Contractor's Construction Schedules.

4.7.1 Progress and Completion.

- a. *Time Is of The Essence; Complete Within Contract Time.* Time is of the essence. By executing the Contractor's Agreement, Contractor confirms that the Contract Time is adequate to perform the Work. Contractor will proceed expeditiously with adequate forces to achieve Substantial Completion within the Contract Time.
- b. *Notice to Proceed and Insurance.* Contractor will not prematurely commence operations on the site or elsewhere before the issuance of a Notice to Proceed by Intermountain and in no event before the effective date of insurance required by Article 10 to be furnished by Contractor. In addition and without limitation of the foregoing, Contractor will not proceed with further Work or services after performing preconstruction services until Contractor receives a subsequent Notice to Proceed.

4.7.2 Schedule Preparation. Contractor, promptly after being awarded the Contract, will prepare and submit for Intermountain's and A/E's review a reasonably detailed CPM schedule for the Work. The schedule will indicate the order, sequence, and interdependence of all items known to be necessary to complete the Work including construction, procurement, fabrication, and delivery of materials and equipment, submittals and approvals of samples, shop drawings, procedures, or other documents. Work items of Intermountain, other Contractors, utilities and other third parties that may affect or be affected by Contractor will be included. If Intermountain is required, by the Contract Documents, to furnish any materials, equipment, or the like, to be incorporated into the Work by Contractor, Contractor will submit, with the first schedule submittal, a letter clearly indicating the dates that such

items are required at the Project site. The critical path should be identified, including the critical paths for interim completion dates and milestones. The CPM schedule will be developed using Primavera, MS Project, or Suretrack unless otherwise authorized by Intermountain Representative. Contractor's schedule will be updated at least once per month and submitted with each pay request. Contractor will maintain an original baseline schedule and will provide Intermountain monthly written reports indicating Contractor's compliance or noncompliance with the original schedule.

- 4.7.3 Initial Contract Time. Unless otherwise specified in the bidding documents, the initial Contract Time is the time identified in the Contractor's Agreement.
- 4.7.4 Interim Completion Dates and Milestones. The schedule must include contractually specified interim completion dates and milestones. The milestone completion dates indicated are considered essential to the satisfactory performance of this Contract and to the coordination of all Work on the Project. The milestone dates listed are not intended to be a complete listing of all Work under this Contract or of interfaces with other Project contractors.
- 4.7.5 Schedule Content Requirements. The schedule will indicate an early completion date for the Project that is no later than the Project's required completion date. The schedule, including all activity duration's will be given in calendar days. The Schedule will also indicate all of the following:
- a. Interfaces with the work of outside contractors (e.g., utilities, power and with any separate Contractor);
 - b. Description of activity including activity number/numbers;
 - c. Estimated duration time for each activity;
 - d. Early start, late start, early finish, late finish date, and predecessor/successors including stop-start relationships with lead and lag time for each activity;
 - e. Float time available to each path of activities;
 - f. Actual start date for each activity begun;
 - g. Actual finish date for each activity completed;
 - h. The percentage complete of each activity in progress or completed;
 - i. Identification of all critical path activities;
 - j. The critical path for the Project, with this path of activities being clearly and easily recognizable on the time-scaled network diagram. The path(s) with the least amount of float time must be identified. Unless otherwise authorized by Intermountain Representative, no more than 40% of all activities may be identified as critical path items. The relationship between non-critical activities and activities on the critical path will be clearly shown on the network diagram;
 - k. Unless otherwise authorized by Intermountain Representative, all activities on the schedule representing construction on the site may not have duration longer than fourteen (14) Days. Construction items that require more than fourteen (14) Days to complete must be broken into identifiable activities on the schedule with durations less than fourteen (14) Days. The sum of these activities represents the total length required to complete that construction item; and
 - l. Additional requirements as specified in the Supplemental General Conditions.
- 4.7.6 Intermountain's Right to Take Exceptions. Intermountain reserves the right to take reasonable exception to activity duration, activity placement, construction logic or time frame for any element of the Work to be scheduled.

- 4.7.7 Float Time. Float time is defined as the amount of time between the earliest start date and the latest start date or between the earliest finish date and the latest finish date of a chain of activities on the Schedule. By a proposal request or modification delivered to Contractor, Intermountain has the right to use the float time for non-critical path activities until Contractor has reallocated such time on a newly submitted schedule.
- 4.7.8 Initial Schedule Submission. No progress payments will be approved until Contractor has submitted a Project detailed CPM schedule for the entire project.
- 4.7.9 Updates. Before any approval of a pay request, Intermountain, A/E and Contractor will review Contractor's schedule compared to the Work completed. Intermountain approves the amount of Work completed as supported by the schedule of values and as verified by the determination of Work completed. If necessary, Contractor will then update and submit to Intermountain the schedule with the pay request; all of which in accordance with Intermountain's approval. All updates will be provided in electronic and hard copy formats. At each scheduled meeting with Intermountain Representative, Contractor will provide at minimum a "three week look ahead" with long lead items identified.
- 4.7.10 Schedule of Submittals. Contractor will prepare and keep current, for A/E's and Intermountain's review, a schedule of submittals required under the Contract Documents which is coordinated with Contractor's construction schedule and allows A/E a reasonable time to review the submittals. This submittal schedule is to be included as part of the construction schedule. Submittals requiring expedited review must be clearly identified as such in the schedule of submittals.
- 4.7.11 Schedule Recovery. If the Work represented by the critical path falls behind by more than seven (7) Days, the project schedule will be redone within fourteen (14) Days showing how Contractor will recover the time. A narrative that addresses the changes in the schedule from the previously submitted schedule will be submitted along with the schedule in both hard copy (appropriate report formats to be determined by Intermountain Representative) and electronic copy. Contractor will comply with the most recent schedules.
- 4.7.12 Schedule Changes and Modifications.
- a. *Contract Time Change Requires Modification*. The Contract Time may only be shortened or extended by a Modification fully executed by Intermountain.
 - b. *Contractor Changing Activity Durations*. Should Contractor, after approval of the complete detailed construction schedule, desire to change his plan of construction, he will submit his requested revisions to Intermountain and A/E along with a written statement of the revisions including a description of the sequence and duration changes for rescheduling the work, methods of maintaining adherence to intermediate milestones and the contract completion date and the reasons for the revisions. If the requested changes are acceptable to Intermountain, which acceptance will not be unreasonably withheld, they will be incorporated into the Schedule in the next reporting period. If after submitting a request for change in the Contract Schedule, Intermountain does not agree with the request, Intermountain will schedule a meeting with Contractor to discuss the differences.
 - c. *Changes in Contract Time*. The critical path schedule as the term is used in the provisions herein will be based on the current version of Contractor's schedule for the Project and accepted by Intermountain just before the commencement of the modification, asserted delay, suspension or interruption. If Contractor believes it is entitled to an extension of Contract Time under the Contract Documents, Contractor will submit a PCO in accordance with Article 7.2 to A/E and Intermountain Representative accompanied by an analysis of the requested time adjustment.

4.7.13 Extensions of Time.

- a. If Substantial Completion of the Project is delayed because of any of the following causes, then the Contract Time will be extended by Modification for a period of time equal to such delay:
 - (i) Labor strikes or lock-outs;
 - (ii) Unusual delay in transportation;
 - (iii) Unforeseen governmental requests or requirements;
 - (iv) A Change in the Work resulting from an instruction by Intermountain or A/E to Contractor subject to the conditions set forth in Section 7.1.5;
 - (v) Unforeseen Subsurface Condition subject to the conditions set forth in Section 7.1.6; or
 - (vi) Any other event or circumstance caused by the willful or negligent act or omission of Intermountain or A/E subject to the conditions set forth in Section 7.1.6.
- b. Contractor will not be entitled to any compensation for delay described in Section 4.7.13, Paragraph a, subparagraphs (i), (ii), and (iii).
- c. In no event will any time extension or cost adjustment be given on account of delay which reasonably should have been anticipated by the Contractor or in circumstances where performance of the Work is, was, or would have been, delayed by any other cause for which the Contractor is not entitled to an extension.
- d. Adverse Weather delays. Completion time will not be extended for normal bad weather or any weather that is reasonably foreseeable at the time of entering into the contract. The time for completion as stated in the contract documents includes due allowance for calendar days on which Work cannot be performed due to weather conditions. The Contractor acknowledges that it may lose days due to weather conditions. Notwithstanding, the Contract Time may be extended (but at no cost to Intermountain) if all of the following are established by the Contractor:
 - (i) That the weather prevented Work from occurring that is on the critical path for the project based upon a critical path schedule previously submitted to Intermountain and to the extent accepted by Intermountain;
 - (ii) There are no concurrent delays attributed to the Contractor;
 - (iii) The Contractor took all reasonable steps to alleviate the impact of the weather and took reasonable attempts to prevent the delay and despite such reasonable actions of Contractor, the weather impacted the critical path as described above; and
 - (iv) One of the following occurred:
 1. The weather was catastrophic, such as a tornado, hurricane, severe wind storm, severe hail storm; or
 2. Based on the full history of information published from the closest station as indicated from the Western Regional Climate Center (Desert Research Institute 2215 Raggio Parkway Reno, Nevada 89512, and as may be described on the website at <http://www.wrcc.dri.edu/summary/>), one or more of the following occurred:
 - a. For any day between November 1 and March 31, the minimum temperature fell below the average minimum temperature plus the extreme low temperature recorded for the month divided by 2.
 - b. For any day between November 1 and March 31, the maximum temperature fell below the monthly average for the minimum temperature.
 - c. The daily precipitation exceeded 75% of the historical one day maximum for the month.

d. The snowfall for the month exceeded 175% of the historical average snow fall for the month.

Contractor will not be entitled to any compensation for Adverse Weather.

4.7.14 Time Extension Request. Unless a shorter time period is set forth herein or in other Contract Documents, any time extension will be requested by Contractor within twenty-one (21) Days after Contractor knew or should have known about the delay and will be supported by the critical path schedule analysis.

4.7.15 Delay in Completion of the Work.

- a. *Prior to Substantial Completion*. For each Day after the expiration of the Contract Time that Contractor has not achieved Substantial Completion, Contractor will pay Intermountain the amount set forth in the Agreement as liquidated damages for Intermountain's loss of use of the Project and the added administrative expense to Intermountain to administer the Project during the period of delay. In addition, Contractor will reimburse Intermountain for any additional Consultant's fees, attorney fees, expert fees, consultant fees, copy costs, and other expenses incurred by Intermountain as a result of the delay. The parties have agreed on this liquidated damages provision because actual damages which will result from a delay in Substantial Completion cannot readily be ascertained at the time of execution of the Agreement and the parties wish to fix such damages as a their reasonable estimate of such actual damages, and not as a penalty. Intermountain may deduct any liquidated damages or reimbursable expenses from any money due or to become due to Contractor. If the amount of liquidated damages and reimbursable expenses exceeds any amounts due to Contractor, Contractor will pay the difference to Intermountain within ten (10) Days after receipt of a written request from Intermountain for payment
- b. *After Substantial Completion*. For each Day that Contractor exceeds the time allowed for completion of the remaining items set forth in the Certificate of Substantial Completion, Contractor will pay to Intermountain as liquidated damages for additional administrative expenses the amount set forth in the Agreement. In addition, Contractor will reimburse Intermountain for any additional Consultant's fees, attorney fees, expert fees, consultant fees, copy costs, and other expenses incurred by Intermountain as a result of the delay in completing such items.
- c. *No Waiver of Intermountain's Rights*. Permitting Contractor to continue any part of the Work after the time fixed for completion or beyond any authorized extension thereof, will in no way operate as a waiver or estoppel on the part of Intermountain of any of its rights under the Contract Documents, including the right to liquidated damages or any other remedies or compensation.

4.8 Documents and Samples at the Site; Certifying "As-Builts". Contractor will maintain at the site for Intermountain, one record copy of the Drawings, Specifications, Addenda, Change Orders and other Modifications, in good order and marked weekly to record changes and selections made during construction, as well as approved Shop Drawings, Product Data, Samples and similar submittals. These items will be available to A/E and will be delivered to A/E for submittal to Intermountain upon completion of the Work, signed by Contractor, certifying that they show complete and exact "as-built" conditions and location, stating sizes, kind of materials, vital piping, conduit locations and similar matters. All notes of encountered or changed conditions will be included.

4.9 Shop Drawings, Product Data and Samples.

- 4.9.1 Not Contract Documents. Shop Drawings, Product Data, Samples and similar submittals are not Contract Documents. The submittal will demonstrate, for those portions of the Work for which the submittal is required, the way Contractor proposes to conform to the information given and the design concept expressed in the Contract Documents.
- 4.9.2 Promptness. Contractor will review, approve and submit to A/E, Shop Drawings, Product Data, Samples and similar submittals required by the Contract Documents with reasonable promptness and in such sequence as to cause no delay in the Work, or the activities of Intermountain or separate contractors.
- 4.9.3 Not Perform Until A/E Approves. Contractor will perform no portion of the Work requiring submittal and review of Shop Drawings, Product Data, Samples or similar submittals until the respective submittal has been approved in writing by A/E. Such Work will be in accordance with the approved submittals.
- 4.9.4 Representations by Contractor. By approving and submitting Shop Drawings, Product Data, Samples and similar submittals, Contractor represents that Contractor has determined and verified materials, field measurements and field construction criteria related thereto, and has checked and coordinated the information contained within such submittals with the requirements of the Work and of the Contract Documents.
- 4.9.5 Contractor's Liability. Contractor will not be relieved of responsibility for deviations from the requirements of the Contract Documents by A/E's approval of Shop Drawings, Product Data, Samples or similar submittals unless Contractor has specifically informed A/E in writing of such deviation at the time of the submittal and A/E has given written approval to the specific deviation. Contractor will not be relieved of responsibility for errors or omissions in Shop Drawings, Product Data, Samples or similar submittals by A/E's review and comment.
- 4.9.6 Direct Specific Attention to Revisions. Contractor will direct specific attention in writing to all revisions on resubmitted Shop Drawings, Product Data, Samples or similar submittals, except those requested by A/E and indicated on previous submittals.
- 4.9.7 Informational Submittals. Informational submittals upon which A/E is not expected to take responsive action may be so identified in the Contract Documents.
- 4.9.8 Reliance on Professional Certification. When professional certification of performance criteria of materials, systems or equipment is required by the Contract Documents, Intermountain and A/E will be entitled to rely upon the accuracy and completeness of such calculations and certifications. If a professional stamp is required, the professional will be licensed in the State in which the Project is located unless otherwise approved by Intermountain in writing. Likewise, Contractor is entitled to rely upon the accuracy and completeness of the calculations made by A/E in developing the Contract Documents, unless a Contractor of ordinary skill and expertise for the type of Work involved would know that such is inaccurate or incomplete and therefore must immediately notify Intermountain in writing.

4.10 Use of Site.

- 4.10.1 In General.
 - a. Contractor will confine operations at the site to areas permitted by the Contract Documents, law, ordinances, resolutions, rules and regulations, and permits and will not unreasonably encumber the site with materials or equipment. Contractor will take all reasonable means to secure the site, protect the site and protect the Work from any damage. The site will be left free and clear of refuse, equipment, materials, etc. and the site will not be subject to spilled liquids and chemicals, toxic or otherwise. Should such an incident occur while Contractor has control of the site, Contractor will be responsible to clean the site and pay all associated costs, fines and penalties.

Notwithstanding this, Contractor is not responsible for any damage to the site or the Work to the extent caused by Intermountain or Intermountain's agents.

- b. Contractor recognizes that the Project site and the surrounding area is frequently visited by the public and is important to Intermountain's image and function and will maintain the premises free from debris and waste materials resulting from Construction. At the completion of Construction, Contractor will promptly remove construction equipment, tools, surplus materials, waste materials and debris.

4.10.2 Access to Neighboring Properties. Contractor will not, except as provided in the Contract Documents or with Intermountain's advance written consent when necessary to perform the Work, interfere with access to properties neighboring the Project site by the owners of such properties and their respective tenants, agents, invitees and guests.

4.11 Access to Work. Contractor will provide Intermountain and A/E access to the Work in preparation and progress, wherever located.

4.12 Royalties and Patents. Contractor will pay all royalties and license fees. Contractor will defend suits or claims for infringement of patent rights and will hold Intermountain and A/E harmless from loss on account thereof, but will not be responsible for such defense or loss when a particular design, process or product of a particular manufacturer or manufacturers is required by the Contract Documents. However, if Contractor has reason to believe that the required design, process or product is an infringement of a patent, Contractor will be responsible for such loss unless such information is promptly furnished to Intermountain in writing.

4.13 Indemnification.

4.13.1 To the fullest extent permitted by law, Contractor will indemnify and hold harmless Intermountain and its affiliates, subsidiaries, officers, employees, agents, authorized volunteers (hereinafter the above listing of entities and persons is referred to as "indemnitees") from and against every kind and character of claims, liabilities, damages, losses, settlements, and expenses, including but not limited to attorneys' fees, consultant fees, expert fees, and other costs and expenses, and including without limitation those events covered under the blanket Contractual Liability Coverage required under the Contract Documents, arising out of or resulting from performance of the Work, including without limitation the work of all the Subcontractors and their employees, except to the extent that such liability arises out of the negligence of Intermountain, its representatives, agents, and employees. This indemnity includes, without limitation, indemnification of Intermountain from all losses or injury to Intermountain's property, except to the extent that such loss or injury arises out of the negligence of Intermountain, its representatives, agents, and employees. This indemnity applies, without limitation, to include Claims occurring both during performance of the Work and/or subsequent to completion of the Work. In the event that any Claim is caused in part by a party indemnified hereunder, that party will bear the cost of such Claim to the extent it was the cause thereof. In the event that a claimant asserts a Claim for recovery against any party indemnified hereunder, the party indemnified hereunder may tender the defense of such Claim to Contractor. If Contractor rejects such tender of defense and it is later determined that the negligence of the party indemnified hereunder did not cause all of the Claim, Contractor will reimburse the party indemnified hereunder for all costs and expenses incurred by that party in defending against the Claim. Contractor will not be liable hereunder to indemnify any party for damages resulting from the sole negligence of that party. Notwithstanding, Intermountain will have the right, at its option, to participate in the defense of any such action without relieving Contractor of any obligation hereunder.

4.13.2 In addition to the foregoing, Contractor will be liable to defend Intermountain in any lawsuit filed by any Subcontractor relating to the Project. Where liens have been filed against Intermountain's property, Contractor (and/or its bonding company which has issued bonds for the Project) will obtain lien releases and record them in the appropriate county and/or local jurisdiction and provide

Intermountain with a title free and clear from any liens of Subcontractors. In the event that Contractor and/or its bonding company are unable to obtain a lien release, Intermountain in its absolute discretion may require Contractor to provide a bond around the lien or a bond to discharge the lien, at Contractor's sole expense.

- 4.13.3 In addition to the foregoing, Contractor will indemnify and hold Intermountain harmless from any claim of any other contractor resulting from the performance, nonperformance or delay in performance of the Work by Contractor.
- 4.13.4 The indemnification obligation under this Article 4.13 will not be limited by a limitation on amount or type of damages, compensation or benefits payable by or for Contractor or Subcontractor under workers' or workmen's compensation acts, disability benefits acts or other employee benefit acts.
- 4.13.5 Intermountain and Contractor waive all rights against each other for damages to the Work during construction to the extent covered by the applicable Builder's Risk Policy, except such rights as they may have to the proceeds of such insurance as set forth in the Contract. Contractor will require similar waivers from its Subcontractors, subconsultants, and agents, at any tier.

4.14 Additional Services/Work. It is understood and agreed by the parties hereto that no money will be paid to Contractor for additional labor or materials furnished unless a new contract in writing or a Modification hereof in accordance with the General Conditions and the Contract Documents for such additional labor or materials has been executed. Intermountain specifically reserves the right to modify or amend the Contract and the total sum due hereunder, either by enlarging or restricting the scope of the Work.

4.15 Building Information Modeling. Contractor will perform, throughout the Project, as requested by Intermountain and/or as otherwise required to execute the Project, building information modeling ("BIM") services and coordination among trades. Such BIM services are included in Contractor's Work and services and shall be provided by Contractor and Subcontractors without additional fee or charge to Intermountain. Contractor will provide BIM services using software acceptable to Intermountain.

5. SUBCONTRACTORS.

5.1 Award of Subcontracts and Other Contracts for Portions of the Work.

5.1.1 Approval Required.

- a. Listing of Subcontractors will be as stated in the Contract Documents, including but not limited to the "Intermountain Subcontractors List Form".
- b. Contractor will not contract with a proposed person or entity to whom Intermountain has made a reasonable and timely objection. Contractor will not be required to contract with anyone to whom Contractor has made reasonable objection.

5.1.2 Business and Licensing Requirements. All Subcontractors used by Contractor will comply with all applicable business and licensing requirements.

5.1.3 Subsequent Changes. After the bid opening, Contractor may change its listed Subcontractors only in accordance with the Contract Documents and with written approval of the Director.

- a. Intermountain will pay the additional costs for an Intermountain requested change in Subcontractor if all of the following are met:
 - (i) If Intermountain in writing requests the change of a Subcontractor;
 - (ii) The original Subcontractor is a responsible Subcontractor that meets the requirements of the Contract Documents; and
 - (iii) The original Subcontractor did not withdraw as a Subcontractor on the project.
- b. In all other circumstances, Contractor will pay the additional cost for a change in a Subcontractor.

- 5.1.4 Bonding of Subcontractors. Subcontractors as identified by Intermountain in the procurement documents, may be required to submit performance and payment bonds to cover the full extent of their portion of the Work. This provision does not in any way limit the right of Contractor to have Subcontractors at any tier be required to have a performance and/or payment bond.
- 5.1.5 Unrelated Subcontractors / Contractor Self-Performed Work.
- a. Contractor will procure bids for subcontract work from at least three (3) qualified bidders unless Intermountain waives such requirement in writing. Except as provided in the following section, Contractor will enter into contracts with Subcontractors not owned, related to or controlled by Contractor to perform all portions of the Work. Subcontracts will contain payment provisions consistent with the Contract Documents and will not be awarded on the basis of cost plus a fee without the prior written consent of Intermountain.
 - b. If Contractor wishes to self-perform any portion of the Work or subcontract such portion of the Work to an entity owned or controlled by or related to Contractor, Contractor will:
 - 1) Advise Intermountain at least thirty (30) Days in advance of bid opening that Contractor wishes to self-perform such Work or subcontract it to an entity owned, controlled by or related to Contractor and request Intermountain's written approval thereof;
 - 2) Submit to Intermountain Contractor's or such related entity's bid at least seventy-two (72) hours prior to bid opening;
 - 3) Procure bids for such subcontract Work from at least three qualified bidders unless Intermountain waives such requirement in writing; and
 - 4) Abide by Intermountain's determination as to whether Contractor or another subcontractor will be used to perform such Work.
 - c. If Intermountain both approves Contractor to self-perform Work and approves Contractor proceeding without obtaining bids from other Contractors, then Contractor's overhead and profit on Work performed by Contractor's crews will not be more than the percentage fee, if any, stated in the Contractor's Agreement or such fee as agreed by Intermountain and Contractor by a written Modification executed prior to Contractor's commencing the applicable self-performed Work.

5.2 Subcontractual Relations.

- 5.2.1 Comply with Contract Documents. By appropriate enforceable agreement, and to the extent it can be practically applied, Contractor will require each Subcontractor to be bound to Contractor by the terms of the Contract Documents, and to assume toward Contractor all the obligations and responsibilities which Contractor, by these Documents, assumes towards Intermountain and A/E.
- 5.2.2 Rights. Each Subcontractor agreement will preserve and protect the rights of Intermountain and A/E under the Contract Documents with respect to the Work to be performed by the Subcontractor so that subcontracting thereof will not prejudice such rights, and will allow to the Subcontractor, unless specifically provided otherwise in the Subcontractor agreement, the benefit of all rights and remedies against Contractor that Contractor, by the Contract Documents, has against Intermountain.
- 5.2.3 Sub-Subcontractors. Contractor will require each Subcontractor to enter into similar agreements with its Subcontractors which complies with the requirements of Paragraphs 5.2.1 and 5.2.2 hereinabove.
- 5.2.4 Document Copies. Contractor will make available to each proposed Subcontractor, before execution of the subcontract agreement, copies of the Contract Documents to which the Subcontractor will be

bound. Subcontractors will similarly make copies of applicable portions of the Contract Documents available to their respective proposed Subcontractors.

5.3 Contingent Assignment of Subcontracts. Each subcontract agreement for a Subcontractor, at any tier for a portion of the Work, is hereby assigned by Contractor to Intermountain provided that the assignment is effective only after termination of the Contract by Intermountain for cause pursuant to Article 12.2 or stoppage of the Work by Intermountain pursuant to Article 12.5, and only for those subcontract agreements which Intermountain accepts by notifying the Subcontractor in writing. The subcontract will be equitably adjusted to meet the new conditions of the work.

6. PROTECTION OF PERSONS AND PROPERTY.

6.1 Safety of Persons and Property.

- 6.1.1 Contractor Responsibility. Contractor will be solely responsible for initiating, maintaining and supervising all safety precautions and programs in connection with the performance of the Contract. Contractor will take all reasonable precautions for the safety of, and will provide reasonable protection to prevent damage, injury or loss to:
- a. Employees on the Work and other persons who may be affected thereby;
 - b. The Work and materials and equipment to be incorporated therein, whether in storage on or off the site, under care, custody or control of Contractor or a Subcontractor; and
 - c. Other property at the site or adjacent thereto, such as trees, shrubs, lawns, walks, pavements, roadways, structures and utilities not designated for removal, relocation or replacement in the course of construction.
- 6.1.2 Safety Program, Precautions. Contractor will institute a safety program at the start of construction to minimize accidents. This program will continue to the final completion of the Project and conform to applicable laws and regulations including the Utah Occupational Safety and Health Rules and Regulations as published by the Utah Industrial Commission - UOSH Division. Contractor will post signs, erect barriers, and provide those items necessary to implement the safety program. As soon as Contractor proceeds with the Work, Contractor will have all workers and all visitors on the site wear safety hard hats, as well as all other appropriate safety apparel such as safety glasses and shoes, and obey all safety rules and regulations and statutes. Contractor will post a sign in a conspicuous location indicating the necessity of wearing hard hats and Contractor will loan such hats to visitors.
- 6.1.3 Compliance with Safety Laws. Contractor will give notices and comply with applicable laws, ordinances, rules, codes, regulations and lawful orders of public authorities bearing on safety of persons or property or their protection from damage, injury or loss.
- 6.1.4 Erect and Maintain Safeguards. Contractor will erect and maintain, as required by existing conditions and performance of the Contract, reasonable safeguards for safety and protection, including effective fences, posting danger signs and other warnings against hazards, promulgating safety regulations and notifying owners and users of adjacent sites and utilities.
- 6.1.5 Utmost Care. When use or storage of explosives or other hazardous materials or equipment or unusual methods are necessary for execution of the Work, Contractor will exercise utmost care and carry on such activities under supervision of properly qualified personnel.
- 6.1.6 Prompt Remedy. Contractor will promptly remedy damage and loss (other than damage or loss insured under property insurance required by the Contract Documents) to property referred to in Paragraph 6.1.1 of these General Conditions caused in whole or in part by Contractor, a Subcontractor, or anyone directly or indirectly employed by any of them, or by anyone for whose acts they may be liable and for which Contractor is responsible under this Paragraph 6.1.1, except to the extent such damage or loss is directly due to errors in the Contract Documents or caused by agents or

employees of A/E or Intermountain. The foregoing obligations of Contractor are in addition to Contractor's obligations under the Contract Documents.

- 6.1.7 Safety Designee. Contractor will designate a responsible member of Contractor's organization at the site whose duty will be the prevention of accidents, damage, injury or loss. This person will be Contractor's superintendent unless otherwise designated by Contractor in writing to Intermountain and A/E.
- 6.1.8 Load Safety. Contractor will not load or permit any part of the construction or site to be loaded so as to endanger its safety.
- 6.1.9 Off-Site Responsibility. In addition to its other obligations under this Article 6, Contractor will, at its sole cost and expense, promptly repair any damage or disturbance to walls, utilities, streets, ways, sidewalks, curbs and the property of Intermountain and third parties (including municipalities and other governmental agencies) resulting from the performance of the Work, whether by it or by its Subcontractors at any tier. Contractor will not cause materials, including soil and debris, to be placed or left on streets or ways.
- 6.1.10 Emergencies. In an emergency affecting safety of persons or property, Contractor will act, at Contractor's discretion, to prevent threatened damage, injury or loss. Contractor will promptly notify Intermountain Representative of the action taken.

6.2 Hazardous Materials. In the event Contractor encounters on the site material reasonably believed to be asbestos or polychlorinated biphenyl (PCB) or any other hazardous waste or substance which may endanger the health of those persons performing the Work or being on the site, Contractor will immediately stop Work in the area affected and immediately report the condition to Intermountain Representative and A/E by phone with a follow-up document in writing. The Work in the affected area will be resumed when written direction is provided by Intermountain Representative. Except to the extent provided otherwise in the Contract Documents or if the presence of hazardous materials is due to the fault of Contractor, Contractor will not be required to perform without Contractor's consent, any Work relating to asbestos, polychlorinated biphenyl (PCB) or any other hazardous waste or substance. Intermountain will procure a licensed abatement contractor qualified to remove the hazardous material. The abatement contractor will submit notification of demolition to the Utah Division of Air Quality. Abatement contractor will pay the notification fee. A copy of the hazardous material survey report will be available to all persons who have access to the construction site.

6.3 Historical and Archeological Considerations. In the event Contractor knows or should have known of any cultural, historical or archeological material that is either recognized as an item to be protected under Federal, State, or local law or regulation, or is an item of obvious value to Intermountain, Contractor will cease any work that would interfere with such discovery and immediately report the condition to Intermountain Representative and A/E by phone with a follow-up document in writing. Work will resume based upon the direction of Intermountain Representative. Contractor cooperation with any Intermountain recognized archaeologist or other cultural/historical expert is required.

6.4 Contractor Liability. If Contractor fails in any of its obligations in Articles 6.1 through 6.3 above, Contractor will be liable to any damages to Intermountain or any third party resulting from such noncompliance. Contractor will also be liable for any mitigation or restoration effort resulting from such noncompliance. To the extent all the following is met, Contractor may treat the discovery of such material similarly to an unforeseen condition:

- 6.4.1 The discovery of such material is reasonably unforeseeable given the site conditions that Contractor should have been aware;
- 6.4.2 The presence of such material was not identified in any part of the Contract Documents;

- 6.4.3 Contractor has undertaken all proper action to mitigate any impact of such discovery on the critical path or monies related to the Project;
- 6.4.4 The discovery affects the critical path or contract price from that which was contemplated by the Contract Documents; and
- 6.4.5 The requirements of 7.1.5 and the Contract documents are met.

7. MODIFICATIONS, REQUEST FOR INFORMATION, PROPOSED CHANGE ORDER, AND CLAIMS PROCESS.

7.1 Modifications: In General.

- 7.1.1 Types of Modifications and Limitations. Changes in the Work may be accomplished after execution of the Contract, and without invalidating the Contract, by Change Order, Construction Change Directive or ASI, subject to the limitations stated in this Article 7 and elsewhere in the Contract Documents. Contractor must have a written Modification executed by Intermountain under this Article 7 before proceeding with any Work sought to be an extra.
- 7.1.2 By Whom Issued. A Change Order or Construction Change Directive will be issued by Intermountain Representative. An ASI is issued by A/E. A/E will prepare Change Orders and Construction Change Directives with specific documentation and data for Intermountain's approval and execution in accordance with the Contract Documents, and may issue ASIs not involving an adjustment in the Contract Sum or an extension of the Contract Time which are not inconsistent with the intent of the Contract Documents.
- 7.1.3 Contractor to Proceed Unless Otherwise Stated. Changes in the Work will be performed under applicable provisions of the Contract Documents, and Contractor will proceed promptly, unless otherwise provided in the Change Order, Construction Change Directive or ASI.
- 7.1.4 Adjusting Unit Prices. If unit prices are stated in the Contract Documents or subsequently agreed upon, and if quantities originally contemplated are so changed in a PCO or Construction Change Directive that application of such unit prices to quantities of Work proposed will cause a substantial inequity to Intermountain or Contractor, the applicable unit prices may be equitably adjusted.
- 7.1.5 Changes in the Work Resulting From An Instruction by Intermountain or A/E to Contractor.
 - a. If Intermountain or A/E gives Contractor an instruction that modifies the requirements of the Contract Documents or delays Substantial Completion, Contractor may be entitled to an adjustment in the Contract Sum and/or the Contract Time. If compliance with the instruction affects the cost to Contractor to perform the Work, the Contract Sum will be adjusted to reflect the reasonable increase or decrease in cost subject to the conditions set forth in Section 7.1.5, subparagraphs b through g. If compliance with the instruction delays Substantial Completion, the Contract Time will be extended for a period of time commensurate with such delay subject to the conditions set forth in Section 7.1.5, subparagraphs b through g and Section 4.7.13.
 - b. If Contractor receives an instruction from Intermountain or A/E that Contractor considers to be a Change in the Work, Contractor, before complying with the instruction, will notify A/E in writing that Contractor considers such instruction to constitute a Change in the Work. If A/E agrees that compliance with the instruction will constitute a Change in the Work, Contractor will furnish a proposal for a Modification in accordance with Section 7.1.5 subparagraphs c and d. within ten (10) Days.
 - c. If Contractor claims that it is entitled to an adjustment in the Contract Sum (including without limitation costs related to a time extension) as a result of an instruction by Intermountain or A/E, Contractor will furnish a proposal for a Change Order containing a price breakdown itemized as required by Intermountain. The breakdown will provide sufficient detail to allow Intermountain to determine any increase or decrease in Direct Costs as a result of compliance with the

instruction. Any amount claimed for subcontracts will be supported by a similar price breakdown and will itemize the Subcontractor's profit and overhead charges. Profit and overhead will be subject to the markup limits for additional work, changes, or other Modification set forth in the Contractor's Agreement. Amounts due Intermountain as a result of a credit change will be the actual net decrease in the Contractor's Direct Costs to perform the Work as a result of the Change in the Work. Overhead and profit for the Modification will be calculated based on the net increase or decrease in Contractor's Direct Costs resulting from the Change in the Work

- d. If Contractor claims that it is entitled to an adjustment in the Contract Time as a result of an instruction from Intermountain or A/E, Contractor will include in its proposal justification to support Contractor's claim that compliance with the instruction will delay Substantial Completion.
- e. Upon receipt of Contractor's proposal for Modification, A/E and Intermountain will determine whether to proceed with the Change in the Work. If A/E and Intermountain determine to proceed with the Change in the Work, they will execute a Change Order, a Construction Change Directive or a Field Change as appropriate.
- f. Contractor agrees that if it complies with an instruction from Intermountain or A/E without first giving written notice to A/E as provided in Section 7.15, subparagraph b, and receiving a Change Order, Construction Change Directive or Field Change, Contractor will not be entitled to any adjustment in the Contract Sum or the Contract Time as a result of the instruction and waives any claim therefor.
- g. If Contractor is instructed to perform work which it claims constitutes a Change in the Work but which Intermountain and A/E do not agree constitutes a Change in the Work, Contractor will comply with the instruction. Contractor may submit its claim for adjustment to the Contract Sum, the Contract Time, or both as a dispute pursuant to Section 7.7 within twenty-one (21) Days after compliance with the instruction. Contractor agrees that if it fails to submit its claim for resolution pursuant to Section 7.7 within twenty-one (21) Days after compliance with the instruction, then Contractor will not be entitled to any adjustment in the Contract Sum or the Contract Time as a result of the instruction and waives any claim therefor.
- h. Contractor agrees that it is responsible for submitting accurate cost and pricing data to support its Change Order Proposals. Intermountain will have the right to examine the Contractor's records to verify the accuracy and appropriateness of the pricing data used to price change order proposals.

7.1.6 Change in the Work Resulting From An Event or Circumstance.

- a. If an event or circumstance other than an instruction from Intermountain or A/E affects the cost to Contractor of performing the Work or delays Substantial Completion, Contractor may be entitled to an adjustment in the Contract Sum and/or the Contract Time. If the circumstance or event affects the cost to Contractor to perform the Work and is caused by a willful or negligent act or omission of Intermountain or A/E or an Unforeseen Subsurface Condition, the Contract Sum will be adjusted to reflect the reasonable increase or decrease in Contractor's cost to perform the Work resulting from the event or circumstance, subject to the conditions set forth in Section 7.1.6, subparagraphs b through f. If the event or circumstance delays Substantial Completion and is described in Section 4.7.13, the Contract Time will be extended for a period of time commensurate with such delay subject to the conditions set forth in such section. If the circumstance or event delays Substantial Completion and is caused by a willful or negligent act or omission of Intermountain or A/E or an Unforeseen Subsurface Condition, then Contractor will

be compensated for costs incident to the delay in accordance with Section 7.1.6, subparagraphs b through g and Section 4.7.13.

- b. Contractor will not be entitled to any adjustment to the Contract Sum or other damages from Intermountain as a result of any event or circumstance unless the event or circumstance results from a willful or negligent act or omission of Intermountain or A/E.
- c. If a Change in the Work results from any event or circumstance caused by the willful or negligent act or omission of Intermountain or A/E or an Unforeseen Subsurface Condition, Contractor will give Intermountain Written Notice of such event or circumstance within twenty-four (24) hours after commencement of the event or circumstance so that Intermountain can take such action as is necessary to mitigate the effect of the event or circumstance. Contractor will not be entitled to any adjustment in either the Contract Time or the Contract Sum based on any damages or delays resulting from such event or circumstance during a period more than twenty-four (24) hours prior to Contractor giving such Written Notice to Intermountain.
- d. Contractor will submit in writing any claims for an adjustment in the Contract Time and/or the Contract Sum resulting from an event or circumstance within the time limits set forth below. In the event that Contractor fails to submit its claim in writing within the time limits set forth below, then Contractor agrees it will not be entitled to any adjustment in the Contract Time or the Contract Sum or to any other damages from Intermountain due to the circumstance or event and waives any claim therefor.
 - (i) Claims for an adjustment in the Contract Time due to Adverse Weather will be made within twenty-one (21) Days of the first Day of the occurrence of the Adverse Weather event in which the delay occurred.
 - (ii) Claims for an adjustment in the Contract Time and/or the Contract Sum due to any other circumstance or event will be submitted within seven (7) Days after the occurrence of the circumstance or event.
- e. If Contractor claims that it is entitled to an adjustment in the Contract Sum (including without limitation costs related to a time extension) because of an event or circumstance resulting from the willful or negligent act or omission of Intermountain or A/E or an Unforeseen Subsurface Condition, Contractor will furnish a proposal for a Change Order containing a price breakdown as described in Section 7.1.5, subparagraph c. Any amount claimed for increased labor costs as a result of the event or circumstance must be supported by a certified payroll. Any claim for rented equipment or additional material costs must be supported by invoices.
- f. If Contractor claims that it is entitled to an adjustment in the Contract Time as a result of an event or circumstance, Contractor will include with its claim copies of daily logs, letters, shipping orders, delivery tickets, Project schedules, and other supporting information necessary to justify Contractor's claim that the event or circumstance delayed Substantial Completion.
- g. Within thirty (30) Days after receipt of Contractor's claim, A/E will either deny the claim or recommend approval to Intermountain. If Intermountain approves the claim, the adjustment in the Contract Time and/or Contract Sum will be reflected in a Change Order pursuant to Section 7.4 or a Construction Change Directive pursuant to Section 7.5. If Intermountain or A/E denies Contractor's claim, Contractor may submit its claim as a dispute pursuant to Section 7.7 within twenty-one (21) Days of receipt of the denial of the claim. If Contractor fails to submit its claim for resolution pursuant to Section 7.7 within the twenty-one (21) Day time period, then Contractor agrees it is not entitled to any adjustment in the Contract Time and/or Contract Sum or any other damages as a result of the event or circumstance and waives any claim therefor.

7.2 Contractor Initiated Requests.

- 7.2.1 The Request for Information, RFI, Process and Time to File. Contractor may file an RFI with A/E regarding any concern which will assist Contractor in the proper completion of the Work including, but not limited to issues related to the Contract Documents, plans and specifications. The RFI will be filed with A/E in a timely manner so as not to prejudice Intermountain as to the quality, time or money related to the Work.
- 7.2.2 Proposed Change Order. Unless a shorter time period is set forth herein or in other Contract Documents, within twenty-one (21) Days after Contractor knows or should have known of a situation or concern where Contractor is going to request additional monies or time, Contractor must file a PCO with Intermountain Representative, or Contractor will be deemed to waive any right to claim additional monies or time related to such situation or concern. The PCO will include all available documentation supporting the PCO available to Contractor at the time of filing and Contractor will thereafter diligently pursue the supplementation(s) of such documentation and promptly deliver such supplementation(s) to Intermountain Representative.
- a. *Intermountain Representative Response.* One of the following may occur after a PCO is filed with Intermountain Representative:
- (i) Intermountain Representative, after considering any input by A/E, may reach an agreement with Contractor and issue a Change Order.
 - (ii) Intermountain, after considering any input by A/E, may issue a Construction Change Directive.
 - (iii) If Intermountain Representative, after considering any input by A/E, disagrees with Contractor's PCO, Intermountain representative may seek additional information or verification from Contractor, A/E or other sources, may negotiate with Contractor, may issue a Change Order upon such later agreement, may retract the PR, or may issue a Construction Change Directive. A/E must continually work with Intermountain in providing data, documentation and efforts to resolve the issues related to the PR.

7.3 Proposal Request Initiated by Intermountain. Intermountain may file a Proposal Request with Contractor seeking information, data and/or pricing relating to a change in the Contract Time and or monies owing for particular scope changes or other modifications to the Contract Documents. The PR will provide a time limit for Contractor to file a response with A/E and Intermountain Representative. If a proposal is not timely provided by Contractor, Intermountain may calculate the Change Order under Article 7.4.2 below. Upon such timely receipt of the proposal, one of the following will occur:

- 7.3.1 If Agreement, Change Order Issued. Intermountain Representative, after considering any input by A/E, may reach an agreement with Contractor and issue a Change Order.
- 7.3.2 If Disagreement. If Intermountain Representative disagrees with Contractor's proposal, after considering any input from A/E, Intermountain representative may seek additional information or verification from Contractor or other sources, may negotiate with Contractor, may issue a Change Order upon such later agreement, may retract the PR, or may issue a Construction Change Directive. If a Construction Change Directive is issued which identifies Intermountain representative's position in regard to the subject contract sum and/or time adjustment, Contractor must initiate the Claim resolution process provided for herein within twenty-one (21) Days of Contractor's receipt of the Construction Change Directive, or Contractor will be deemed to waive any such request for additional time or money as a result of the issuance of the Construction Change Directive. Such waiver will entitle Intermountain to convert the Construction Change Directive into a Change Order, whether or not executed by Contractor. If the Construction Change Directive leaves open the determination of additional time or money related to the directed change, then the time period for initiating the Claim resolution process will not accrue until such time as Intermountain has conveyed to Contractor a position as to the time and money owing as a result of the directed change.

7.4 Evaluation of Proposal for Issuing Change Orders.

- 7.4.1 Adjusting Sum Based Upon Agreement. If the Change Order provides for an adjustment to the Contract Sum, the adjustment will be based on the mutual agreement of Contractor and Intermountain, including any terms mandated by unit price agreements or other terms of the Contract Documents.
- 7.4.2 Intermountain Resolution of Sum and Standards in the Absence of an Agreement Under Paragraph 7.4.1. In the absence of an agreement under Paragraph 7.4.1 above, the adjustment will be based on an itemized accounting of costs and savings supported by appropriate data. Unless otherwise provided in the Contract Documents, costs for the purposes of this Paragraph will be limited to the following:
- a. All direct and indirect costs of labor; including workers compensation insurance, social security and other federal and state payroll based taxes, and payroll based fringe benefits paid by Contractor so long as they are reasonable and no higher than that charged to other clients;
 - b. Costs of materials, on-site temporary facilities, supplies and equipment (except hand tools) required for or incorporated into the work;
 - c. Rental costs of machinery, equipment, tools (except hand tools), and on-site temporary facilities, whether rented from Contractor or others;
 - d. Costs of permits and other fees, sales, use or similar taxes related to the Work (with no markup);
 - e. Additional costs of field supervision and field office personnel directly attributable to the change; and
 - f. Overhead and profit by the markup limits in the Agreement for additional services or modifications which is not a penalty but a reasonable calculation agreed upon at the time of execution of the Agreement, and provided therein due to the fact that the actual amount due for this overhead and profit cannot easily be ascertained at the time of such execution. The markups set forth in the Agreement are to cover additional payment and performance bond premiums, insurance premiums, home office and on-site overhead and profit. Overhead and profit includes, but is not limited to Contractor's Project Manager and Cost Estimator. Each request for pricing will stand on its own and not be combined with other requests for pricing in determining the allowed markup. A particular request for pricing will include all items reasonably related together and determinable at the time of the request. If several unrelated requests for pricing are grouped together in a single Change Order, each request for pricing will be considered separately for purposes of calculating the markup.
- 7.4.3 Credits. The amount of credit to be allowed by Contractor to Intermountain for a deletion or change which results in a net decrease in the Contract Sum will be actual net cost as confirmed to Intermountain based upon corroboration by an appropriate source.

7.5 Construction Change Directives.

- 7.5.1 When Used and Contractor's Right to Challenge. A Construction Change Directive may be issued by Intermountain Representative in the case of a need for the Work to commence. If the Construction Change Directive leaves open the determination of additional time or money related to the directed change, then the Construction Change Directive will indicate the timeframe(s) in which further information is to be provided to resolve the matter. At any time that Intermountain and Contractor agree upon the time and money related to a Construction Change Directive, a Change Order will be executed by the parties. Additionally, the Construction Change Directive may be converted to a Change Order under Paragraph 7.2.2 or Article 7.3 above.
- 7.5.2 Proceed with Work and Notify Intermountain about Adjustment Method. Upon receipt of a Construction Change Directive, Contractor will promptly proceed with the change in the Work involved.

7.5.3 Interim Payments by Intermountain. Pending the final determination of the total cost of the Construction Change Directive, Intermountain will pay any undisputed amount to Contractor.

7.6 A/E's Supplemental Instruction (Commonly referred to as an "ASI"). A/E may at any time that is consistent with maintaining the quality, safety, time, budget and function of the Work, issue to Contractor a supplemental instruction ("ASI") after approval from Intermountain Representative is obtained. Contractor must file with Intermountain Representative a PCO under Paragraph 7.2.2 above, within twenty-one (21) Days of Contractor's receipt of the ASI, or the Contractor will be deemed to have waived any right to additional time or monies as a result of such ASI.

7.7 Resolution of Disputes. If a dispute arises between the Parties regarding the Contract Documents which is not resolved by agreement between the parties, before a party may proceed with judicial action, the dispute must be submitted in writing to Intermountain's Vice President of Financial Strategy, Growth and Development, at 36 South State Street, Salt Lake City, Utah 84111. Upon receipt of such written submission, Intermountain will schedule within seven (7) Days an initial conference or meeting, and if necessary within an additional ten (10) Days thereafter a further conference or meeting, as set forth in the escalation process herein below.

7.7.1 Escalation Process. The Parties will arrange in-person meetings or telephone conferences at mutually convenient times and places, according to the levels and time schedules set forth below. The Parties will use reasonable and good faith efforts in this escalation process to respond promptly and to resolve the dispute. Such meetings or conferences will constitute settlement negotiations and any settlement proposal made pursuant to such meetings or conferences will not be admissible as evidence of liability.

<u>Levels and Representatives</u>	<u>Allotted Time Period from Notice or from Previous Level</u>
<u>Level 1</u>	
Contractor's Director level employee, and Intermountain's Director	7 Days
<u>Level 2</u>	
Vice President or higher level executive	10 Days

7.7.2 Judicial Action. In the event that the parties do not resolve their dispute pursuant to the escalation process, either party may commence legal action to resolve the dispute. Any such action must be commenced within six (6) months from the first day of the initial Level 1 conference/meeting or be time barred. Submission of the dispute under the escalation process as outlined above is a condition precedent to the right to commence legal action to resolve any dispute. In the event that either party commences legal action to adjudicate any dispute without first submitting the dispute under the escalation process, the other party will be entitled to obtain an order dismissing the litigation without prejudice and awarding such other party any costs and attorney fees incurred by that party in obtaining the dismissal, including without limitation copy costs, and expert and consultant fees and expenses. Any such legal action must be brought exclusively in the state courts of the State of Utah or in the federal courts of the United States which are located in Salt Lake County, Utah. The Parties hereto hereby agree to submit to the exclusive jurisdiction and venue of such courts for the purposes hereof.

7.7.3 Continuation of Performance During Proceedings. Pending final resolution of a dispute hereunder, Contractor will proceed diligently with the performance of its obligations under the Contract Documents.

7.8 Payment of Claim.

- 7.8.1 When a standalone component of a Claim has received a final determination, and is no longer subject to review or appeal, that amount will be paid in accordance with the payment provisions of the Contract Documents or judicial order.
- 7.8.2 When the entire Claim has received a final determination, and is no longer subject to review or appeal, the full amount will be paid within thirty-one (31) Days of the date of the final determination unless the work or services has not been completed, in which case the amount will be paid in accordance with the payment provisions of the Contract Documents to the point that the work or services is completed.
- 7.8.3 The final determination date is the earlier of the date upon which the claimant accepted the settlement in writing with an executed customary release document and waived its rights of appeal, or the expiration of the appeal period, with no appeal filed, or the determination made resulting from the final appeal.
- 7.8.4 Any final determination where Intermountain is to pay additional monies to Contractor will not be delayed by any appeal or request for judicial review by another party brought into the process by Intermountain as being liable to Intermountain.
- 7.8.5 Notwithstanding any other provision of the Contract Documents, payment of all or part of a Claim is subject to any set-off, claims or counterclaims of Intermountain.
- 7.8.6 Payment to Contractor for a Subcontractor issue (Claim) deemed filed by Contractor, will be paid by Contractor to the Subcontractor in accordance with the contract between Contractor and the Subcontractor.
- 7.8.7 The execution of a customary release document related to any payment may be required as a condition of making the payment.

7.9 Allocation of Costs of Claim Resolution Process.

- 7.9.1 Except for attorneys' fees and expert fees, and unless otherwise agreed to by the parties to the Claim, the costs of resolving the Claim will be allocated among the parties on the same proportionate basis as the determination of financial responsibility for the Claim. The costs of resolving the Claim that are subject to allocation include the claimant's filing fee, the costs of any person(s) evaluating the Claim, the costs of making any required record of the process, and any additional testing or inspection procured to investigate and/or evaluate the Claim.
- 7.9.2 The prevailing party in any Claim, judicial action or other proceeding is entitled to recover its reasonable attorneys' fees, expert and other fees, and costs incurred in the proceeding, in addition to any other relief to which that party may be entitled.

7.10 Alternative Procedures. To the extent otherwise permitted by law, if all parties to a Claim agree in writing, a protocol for resolving a Claim may be used that differs from the process described in this Article 7.

8. PAYMENTS AND COMPLETION.

8.1 Schedule of Values. With the first Application for Payment, Contractor will submit to A/E and Intermountain Representative a schedule of values allocated to all the various portions of the Work. The Schedule of Values will be submitted on the form approved and provided by Intermountain. A/E will make recommendations to Intermountain Representative regarding the Schedule of Values including any suggested modifications. When approved, including any approved modifications, by Intermountain Representative, it will be the basis for future Contractor Applications for Payments. Contractor will not be entitled to payment until receipt and acceptance of the Schedule of Values.

8.2 Applications for Payment.

8.2.1 In General. The following general requirements will be met:

- a. Not more than once a month, Contractor will submit to A/E an itemized Application for Payment for Work completed in accordance with the schedule of values and that reflects retainage as provided for in the Contractor's Agreement. Contractor's Applications for Payment will include conditional or final lien waivers (as applicable), in the forms attached to Contractor's Agreement for itself and from each Subcontractor requesting payment, covering all payments requested in the Application for Payment. The Application for Payment will be on a form provided by Intermountain.
- b. Such application will be supported by such data substantiating Contractor's right to payment as Intermountain or A/E may require. This data may include, but is not limited to, copies of requisitions from Subcontractors.
- c. Such applications may include requests for payment pursuant to approved Change Orders or Construction Change Directives.
- d. Such applications may not include requests for payment for portions of the Work performed by a Subcontractor when Contractor does not intend to pay to a Subcontractor because of a dispute or other reason.
- e. In executing the Application for Payment, Contractor will attest that Subcontractors involved with prior applications for payment have been paid, unless Contractor provides a detailed explanation why such payment may not have occurred. Intermountain reserves the right to require Contractor to submit a payment waiver from one or more Subcontractors.

8.2.2 Payment for Material and Equipment. Unless otherwise provided in the Contract Documents, payments will be made on account of materials and equipment delivered and suitably stored at the site for subsequent incorporation in the Work. If approved in advance by Intermountain and A/E, payment may similarly be made for materials and equipment suitably stored off the site at a location agreed upon in writing. Payment for materials and equipment stored on or off the site will be conditioned upon compliance by Contractor with procedures satisfactory to Intermountain to establish Intermountain's title to such materials and equipment or otherwise protect Intermountain's interest, and will include applicable insurance, storage and transportation to the site for such materials and equipment stored off the site. Intermountain may require copies of invoices or other suitable documentation.

8.2.3 Warranty of Title. Contractor warrants that title to all Work covered by an Application for Payment will pass to Intermountain no later than the time for payment. Contractor further warrants that upon submittal of an Application for Payment, all Work for which Certificates for Payment have been previously issued and payments received from Intermountain will, to the best of Contractor's knowledge, information and belief, be free and clear of liens, claims, security interests or encumbrances in favor of Contractor, Subcontractors, or other persons or entities making a claim by reason of having provided labor, materials and/or equipment relating to the Work.

8.2.4 Retainage and Holdback by Intermountain.

- a. *Holdback by Intermountain*. Notwithstanding anything to the contrary contained in the Contract Documents, Intermountain may, as a result of the Claim resolution process, withhold any payment to Contractor hereunder if and for so long as Contractor fails to perform any of its obligations hereunder or otherwise is in default under any of the Contract Documents.
- b. *Intermountain's Right to Withhold and Use Funds*. Intermountain may withhold from payment to Contractor such amount as, in Intermountain's judgment, may be necessary to pay just claims against Contractor or Subcontractors at any tier for labor and services rendered and materials furnished in and about the Work. Intermountain may apply such withheld amounts for the

payment of such claims in Intermountain's discretion. In so doing, Intermountain will be deemed the agent of Contractor and payment so made by Intermountain will be considered as payment made under the Contract by Intermountain to Contractor. Intermountain will not be liable to Contractor for any such payment properly made. Such withholdings and payments may be made without prior approval of Contractor and may also be made before any determination as a result of any dispute, Claim or litigation. However, Contractor will be notified before any such withholding and will be given an opportunity to inform Intermountain as to any reason why the withholding will not occur.

- c. *Statutory Retainage.* Notwithstanding and in addition, retainage in the amount of 5% will be withheld from each payment to Contractor for any Work under the Contract. The retainage, including any additional retainage imposed and the release of any retainage, will be in accordance with Intermountain policies, including restrictions of retainage regarding Subcontractors and the distribution of interest earned on the retention proceeds. After Contractor achieves Substantial Completion and submits its payment request for retained funds and provides statutory Conditional Waiver and Release documents executed by all subcontractors and suppliers having claim against the retained funds, Intermountain will pay any unpaid statutory retention, less any offsets or withholdings for specific deficiencies or disputes, within forty-five (45) Days. Notwithstanding the foregoing, Intermountain may (but is not obligated to), in its sole discretion, release from time to time any portion of retention funds for early completing subcontractors and/or otherwise reduce the overall retention funds withheld.
- d. *Intermountain Not Responsible for Contractor's Retention Requirements.* Intermountain will not be responsible for enforcing Contractor's obligations under Utah law in fulfilling the retention law requirements with Subcontractors at any tier.

- 8.2.5 Reimbursement to Intermountain. Notwithstanding any other provision of the Contract, Contractor will reimburse Intermountain for the portion of any expenses paid by Intermountain to Contractor, which is attributable to Contractor's breach of its duties under the Contract, including the breach of any duty by any Subcontractor or supplier at any tier or anyone for whom Contractor may be liable.

8.3 Certificates for Payment.

- 8.3.1 Issued by A/E. A/E will within ten (10) Days after receipt of Contractor's Application for Payment, either issue to Intermountain a Certificate for Payment, with a copy to Contractor, for such amount as A/E determines due, or notify Contractor and Intermountain in writing of A/E's reasons for withholding certification in whole or in part as provided in Paragraph 8.4.1. If A/E fails to act within this ten (10) Day period, Contractor may file the Application for Payment directly with Intermountain Representative and Intermountain will thereafter have thirty-one (31) Days from the date of Intermountain's receipt to resolve the amount to be paid and to pay the undisputed amount. The accuracy of Contractor's Applications for Payment will be Contractor's responsibility, not A/E's.
- 8.3.2 A/E's Representations. A/E's issuance of a Certificate for Payment will constitute a representation to Intermountain that to the best of A/E's knowledge, information and belief, based upon A/E's observations at the site, the data comprising the Application for Payment, and what is reasonably inferable from the observations and data, that the Work has progressed to the point indicated in the Application for Payment and that the quality of the work is in accordance with the Contract Documents. The foregoing representations are subject to minor deviations from the Contract Documents correctable before completion and to specific qualifications expressed by A/E. The issuance of a Certificate for Payment will further constitute a representation that Contractor is entitled to payment in the amount certified. However, the issuance of a Certificate for Payment will not be a representation that A/E has (a) made exhaustive or continuous on-site inspections to check the quality or quantity of the Work, (b) reviewed construction means, methods, techniques, sequences or procedures, (c) reviewed copies of requisitions received from Subcontractors and material suppliers and other data requested by Intermountain to substantiate Contractor's right to

payment, (d) ascertained how or for what purpose Contractor used money previously paid on account of Contract Sum, or (e) any duty to make such inquiries.

- 8.3.3 Contractor Respond to Financial Responsibility and Related Requests, Waivers, Releases, Bonds. Contractor will respond immediately to any inquiry in writing by Intermountain as to any concern of financial responsibility and Intermountain reserves the right to request any waivers, releases or bonds from Contractor in regard to any rights of Subcontractors (including suppliers) at any tier or any third-party before any payment by Intermountain to Contractor.

8.4 Decisions to Withhold Certification.

8.4.1 When Withheld. A/E may decide not to certify payment and may withhold a Certificate for Payment in whole or in part, to the extent reasonably necessary to protect Intermountain, if in A/E's judgment the representations to Intermountain required in Paragraph 8.3.2 above cannot be made. If A/E is unable to certify payment in the amount of the Application, A/E will notify Contractor and Intermountain as provided in Paragraph above. If Contractor and A/E cannot agree on a revised amount, A/E will promptly issue a Certificate for Payment for the amount to which A/E makes such representations to Intermountain. A/E may also decide not to certify payment or, because of subsequently discovered evidence or observations, may nullify the whole or part of a Certificate for Payment previously issued, to such extent as may be necessary in A/E's opinion to protect Intermountain from loss because of:

- a. Defective Work not remedied;
- b. Third party claims filed or reasonable evidence indicating probable filing of such claims;
- c. Failure of Contractor to make payments properly to Subcontractors or for labor, materials or equipment;
- d. Reasonable evidence that the Work cannot be completed for the unpaid balance of the Contract Sum;
- e. Damage to Intermountain or another contractor;
- f. Reasonable evidence that the Work will not be completed within the Contract Time, and that the unpaid balance would not be adequate to cover actual or liquidated damages for the anticipated delay; or
- g. Failure to carry out the Work in accordance with the Contract Documents.

8.4.2 Certification Issued When Reasons for Withholding Removed. When the reasons stated in Paragraph 8.4.1 for withholding certification are removed, certification will be made for such related amounts.

8.4.3 Continue Work Even If Contractor Disputes A/E's Determination. If Contractor disputes any determination by A/E or the result of the Claim resolution process with regard to any Certification of Payment, Contractor nevertheless will expeditiously continue to prosecute the Work.

8.4.4 Intermountain Not in Breach. Intermountain will not be deemed to be in breach of this Contract by reason of the withholding of any payment pursuant to any provision of the Contract Documents provided Intermountain's action or such withholding is consistent with the results of the dispute resolution process.

8.5 Progress Payments.

8.5.1 In General, Interest on Late Payments.

- a. Except as provided in Paragraph 8.3.1, Intermountain will pay any undisputed amount within thirty-one (31) Days of satisfaction of the following requirements: (i) Contractor has submitted the application for payment; (ii) A/E has issued to Intermountain a Certificate recommending payment; and (iii) Contractor has obtained conditional or unconditional waiver and release

documents executed by all of Subcontractors performing work and/or providing materials covered by the Contractor's payment request. In no event will Intermountain be required to pay any disputed amount.

- b. Except as otherwise provided by law, if any payment is made more than sixty (60) Days after receipt by Intermountain of the applicable invoice (with any required supporting documentation), the late payment will bear interest from the due date until payment is made at the rate of five percent (5%) per annum.

- 8.5.2 Contractor and Subcontractor Responsibility. Contractor will promptly pay each Subcontractor, upon receipt of payment from Intermountain, out of the amount paid to Contractor on account of such Subcontractor's portion of the Work, the amount to which this Subcontractor is entitled. Contractor will, by appropriate agreement with each Subcontractor, require each Subcontractor to make payment to its Subcontractors in a similar manner.
- 8.5.3 Information Furnished by A/E Or Intermountain to Subcontractor. A/E or Intermountain will, on request, furnish to the Subcontractor, if practicable, information regarding percentages of completion or amounts applied for by Contractor and action taken thereon by A/E and Intermountain on account of portions of the Work done by such Subcontractor.
- 8.5.4 Intermountain and A/E Not Liable. Neither Intermountain nor A/E will have an obligation to pay, monitor or enforce the payment of money to a Subcontractor, except to the extent as may otherwise be required by law.
- 8.5.5 Certificate, Payment or Use Not Acceptance of Improper Work. A Certificate for Payment, a progress payment, or partial or entire use or occupancy of the Project by Intermountain will not constitute acceptance of Work that is not in accordance with the Contract Documents.

8.6 Payment upon Substantial Completion. Upon Substantial Completion of the Work or designated portion thereof and upon application by Contractor and certification by A/E, Intermountain will make payment, reflecting adjustment in retainage, if any, for such Work or portion thereof as provided in the Contract Documents. To the extent allowed by law, Intermountain may retain up to 200% of the fair market value of the work that has not been completed in accordance with the Contract Documents.

8.7 Partial Occupancy or Use.

- 8.7.1 In General. Intermountain may occupy or use any completed or partially completed portion of the Work at any stage when such portion is designated by separate agreement with Contractor, and authorized by public authorities having jurisdiction over the Work. Such partial occupancy or use may commence whether or not the portion is Substantially Complete, provided Intermountain and Contractor have accepted in writing the responsibilities assigned to each of them for payments, retainage if any, security, maintenance, heat, utilities, damage to the Work and insurance, and have agreed in writing concerning the period for correction of the Work and commencement of the warranties required by the Contract Documents. When Contractor considers a portion to be substantially complete, Contractor will prepare and submit a list to A/E as previously provided for herein. Consent of Contractor to partial occupancy or use will not be unreasonably withheld. Contractor will have continuing responsibility to protect the unoccupied portions of the site and the Work during such partial occupancy and will be responsible for damage except to the extent caused solely by Intermountain during such partial occupancy or use.

The stage of progress of the Work will be determined by written agreement between Intermountain and Contractor.

- 8.7.2 Inspection. Immediately before such partial occupancy or use, Intermountain, Contractor and A/E will jointly inspect the area to be occupied or portion of the Work to be used in order to determine and record the condition of the Work.

- 8.7.3 Not Constitute Acceptance. Except to the extent it is agreed upon in writing by Intermountain, partial occupancy or use of a portion or portion of the Work will not constitute acceptance of Work not complying with the requirement of the Contract Documents.

8.8 Final Payment.

- 8.8.1 Certificate for Payment. A/E's final Certificate for Payment will constitute a further representation that the conditions listed in Paragraph 8.8.2 as precedent to Contractor's being entitled to final payment have been fulfilled.
- 8.8.2 Conditions for Final Payment. Neither final payment nor any remaining retained percentage will become due until Contractor submits to A/E the following to the extent required by Intermountain Representative:
- a. A final payment request;
 - b. Waiver and release upon final payment documents executed by all of the Subcontractors performing work and/or providing materials covered by the Contractor's final payment request;
 - c. All manufacturers' and other guaranties and warranties, properly signed and endorsed to Intermountain, that are required by the Contract Documents that extend for a period beyond one year after substantial completion. (Delivery of such guaranties and warranties will not relieve Contractor for any obligation assumed under any other provision of the Contract Documents.);
 - d. An affidavit that payrolls, bills for material and equipment, and other indebtedness connected with the Work for which Intermountain's property might be responsible or encumbered (less amounts withheld by Intermountain) have been paid or otherwise satisfied;
 - e. A current or additional certificate evidencing that insurance required by the Contract Documents to remain in force after final payment is currently in effect and will not be canceled or allowed to expire until at least thirty (30) Days prior written notice, by certified mail, return receipt requested, has been given to Intermountain;
 - f. A written statement that Contractor knows of no substantial reason that the insurance will not be renewable to cover the period required by the Contract Documents;
 - g. If requested by surety in a timely manner or by Intermountain, consent of surety, to final payment;
 - h. Up to date as built Drawings certified by Contractor as accurate and complete, Specifications, Addenda, Change Orders and other Modifications maintained at the site; the warranties, instructions, operation and maintenance manuals, and training videos required to be furnished by the Contract Documents;
 - i. Other data establishing payment or satisfaction of obligations, such as receipts, releases and waivers of liens, claims, security interests or encumbrances arising out of the Contract, to the extent and in such form as may be designated by Intermountain. If a Subcontractor refuses to furnish a release or waiver required by Intermountain, Intermountain may require consent of surety to the final payment. If such liens, claims, security interests or encumbrances remain unsatisfied after payments are made, Contractor will refund to Intermountain all money that Intermountain may be compelled to pay in discharging such lien, including all costs and reasonable attorneys' fees; and
 - j. A written statement demonstrating how Contractor will distribute interest earned on retention to Subcontractors as required by Section 13.8.5, U.C.A.

In addition, A/E must declare to Intermountain in writing that the Work is complete. If the aggregate of previous payments made by Intermountain exceeds the amount due Contractor, Contractor will reimburse the difference to Intermountain within ten (10) Days of Intermountain's request.

- 8.8.3 Waiver of Claims: Final Payment. The making of final payment will not constitute a waiver of Claims or other rights by Intermountain.
- 8.8.4 Waiver by Accepting Final Payment. Acceptance of final payment by Contractor or a Subcontractor will constitute a waiver of Claims by that payee except those Claims previously made in writing and identified by that payee as unsettled at the time of final Application for Payment.
- 8.8.5 Time of Repose and Waiver. In addition and notwithstanding, claims and invoices for work, equipment, services, or materials that are not submitted to Intermountain within one (1) year of Substantial Completion of the Project are completely void and unenforceable as against Intermountain. Contractor and all Subcontractors hereby waive all rights and claims against Intermountain attendant such claims and invoices, and Contractor will contractually obligate each Subcontractor to waive all rights and claims against Intermountain attendant such claims and invoices. This provision imposes an absolute cut off on the timing for submitting such claims and invoices; this provision does not lengthen any timing requirements in the Contract Documents.

9. TESTS AND INSPECTIONS, SUBSTANTIAL AND FINAL COMPLETION, UNCOVERING, CORRECTION OF WORK, AND GUARANTY PERIOD.

9.1 Tests and Inspections.

- 9.1.1 In General. Tests, inspections and approvals of portions of the Work required by the Contract Documents or by laws, ordinances, rules, regulations, resolutions or orders of public authorities having jurisdiction will be made at an appropriate time. Unless otherwise specifically set forth in the Contract Documents or agreed to by Intermountain in writing, Intermountain will contract for such tests, inspections and approvals with an independent entity, or with the appropriate public authority, and Intermountain will bear all related costs of tests, inspections and approvals except as provided below. If any of the Work is required to be inspected or approved by the terms of the Contract Documents or by any public authority, Contractor will, at least two working days before the time of the desired inspection, and following the procedures established by Intermountain, request such inspection or approval to be performed. Contractor will give A/E timely notice of when and where tests and inspections are to be made so that A/E may observe such procedures.
- 9.1.2 Failure of An Inspector to Appear. Work will not proceed without any required inspection and the associated authorization by Intermountain to proceed unless the following procedures and requirements have been met:
- a. The inspection or approval was requested in a timely manner as provided in Paragraph 9.1.1;
 - b. Contractor received written confirmation from the inspection entity that the inspection was scheduled;
 - c. Contractor has contacted or attempted to contact the inspector to confirm that the inspector is unable to perform the inspection as scheduled;
 - d. If the inspector has confirmed that it is unable to perform the inspection as scheduled or if Contractor is unable to contact the inspector, Contractor will attempt to contact Intermountain Representative for instruction; and Contractor has documented the condition of the work before being covered through photos or other means.
- 9.1.3 Nonconforming Work. If such procedures for testing, inspection or approval under Paragraph 9.1.1 reveal failure of portions of the Work to comply with the requirements established by the Contract Documents, Contractor will bear all costs made necessary by such failure including those of repeated procedures and compensation for Intermountain's expenses, including the cost of retesting for verification of compliance if necessary, until Intermountain accepts the Work in question as complying with the requirements of the Contract Documents.
- 9.1.4 Certificates. Required certificates of testing, inspection or approval will, unless otherwise required by the Contract Documents, be secured by Contractor and promptly delivered to A/E.

- 9.1.5 A/E Observing. If A/E is to observe tests, inspections or approvals required by the Contract Documents, A/E will do so with reasonable promptness and, where practicable, at the normal place of testing.
- 9.1.6 Promptness. Tests, inspections and arrangements for approvals conducted pursuant to the Contract Documents will be made promptly to avoid unreasonable delay in the Work.

9.2 Inspections: Substantial and Final.

- 9.2.1 Substantial Completion Inspection. Before requesting a substantial completion inspection, Contractor will prepare a comprehensive initial punchlist, including unresolved items from prior inspections, for review by Intermountain and A/E to determine if the Project is ready for a substantial completion inspection. If Intermountain determines that the initial punchlist indicates that the Project is not substantially complete, the initial punchlist will be returned to Contractor with written comments. If Intermountain determines that the initial punchlist indicates that the Project may be substantially complete, A/E will promptly organize and perform a Substantial Completion inspection in the presence of Intermountain and all appropriate authorities.
- a. If A/E reasonably determines that the initial punchlist prepared by Contractor substantially understates the amount of the Work remaining to be completed and the Project is not substantially complete, A/E will report this promptly to Intermountain, and upon concurrence of Intermountain, Contractor will be assessed the costs of the inspection and punchlist preparation incurred by A/E and Intermountain.
 - b. When the Work or designated portion thereof is Substantially Complete, A/E will prepare a Certificate of Substantial Completion which will establish the date of Substantial Completion; will establish responsibilities of Intermountain and Contractor for security, maintenance, heat, utilities, damage to the work and insurance; and will fix the time within which Contractor will finish all items on the punchlist accompanying the Certificate. The Certificate of Substantial Completion will require approval by Intermountain Representative. If there is a punchlist, Contractor will proceed promptly to complete and correct items on the list. Failure to include an item on the punchlist does not alter the responsibility of Contractor to complete all Work in accordance with the Contract Documents.
 - c. Warranties required by the Contract Documents will commence on the date of Substantial Completion of the Work or designated portion thereof except to the extent as provided otherwise in the Contract Documents or if such warranty is related to an item where the work is not complete. Such warranty documents will state the length of the warranty, which must comply with the Contract Documents.
 - d. The Certificate of Substantial Completion will be submitted by A/E to Intermountain and Contractor for their written acceptance of responsibilities assigned to them in such Certificate.
 - e. Except to the extent Intermountain Representative otherwise approves in advance and in writing, Contractor will submit the following documents in order to achieve Substantial Completion: written warranties, guarantees, operation and maintenance manuals, and all complete as-built drawings. Contractor must also provide or obtain any required approvals for occupancy. Contractor is responsible for the guaranty of all Work, whether performed by it or by its Subcontractors at any tier.
- 9.2.2 Final Completion Inspection. Before requesting a final inspection, Contractor will verify all punchlist items are corrected/completed. Once all punchlist items are corrected/completed Contractor will notify Intermountain and request a final inspection. Intermountain will notify A/E and perform a final inspection. Two final inspections may be allowed due to required weather changes required to complete some items. When all punchlist items are completed a final pay request will be provided by Contractor, authorized by A/E and processed by Intermountain.

9.3 Uncovering of Work.

- 9.3.1 Uncover Uninspected Work. Except as provided in Paragraph 9.3.3, if a portion of the Work is covered before an Inspector's approval to proceed, it must, be uncovered for the Inspector's inspection and be replaced at Contractor's expense without change in the Contract Time.
- 9.3.2 Observation before Covering. Except as provided in Paragraph 9.3.3, if Intermountain or A/E has requested in writing to observe conditions before any Work being covered or if such observation is specified in the Contract Documents, and the Work is covered without such observation, Contractor will be required to uncover and appropriately replace the Work at Contractor's expense without change in the Contract Time. If Contractor requests an inspection and Intermountain or A/E, including any inspector of each, does not appear, Contractor will immediately notify Intermountain of such lack of appearance, but will not cover the Work without such inspection.
- 9.3.3 When an Inspector Fails to Appear Or A/E Or Intermountain Did Not Make Prior Request. If Work is performed by Contractor without an inspection as provided in Paragraph 9.1.2 or if a portion of the Work has been covered which A/E or Intermountain has not specifically requested to observe before its being covered or such observation is not specified by the Contract Documents, A/E or Intermountain may request to see such Work and it will be uncovered by Contractor. If such Work is in accordance with the Contract Documents, costs of uncovering and replacement, will, by appropriate Change Order, be charged to Intermountain. If such Work is not in accordance with the Contract Documents, Contractor will pay such costs unless the condition was caused by Intermountain or a separate contractor in which event Intermountain will be responsible for payment of such costs.

9.4 Correction of Work and Guaranty Period.

- 9.4.1 Contractor Correct the Work. Contractor will correct Work rejected by A/E, Inspector or Intermountain, or failing to conform to the requirements of the Contract Documents, whether observed before or after Substantial Completion and whether or not fabricated, installed or completed. Contractor will bear the costs of correcting such rejected Work, including additional testing and inspections and compensation for A/E's and Inspector's services and expenses made necessary thereby.
- 9.4.2 Guaranty and Correction after Substantial Completion. If within one year after the date of Substantial Completion of the Work or designated portion thereof, or after the date for commencement of warranties established under Paragraph 9.2.1 or by terms of an applicable special warranty or guaranty required by the Contract Documents, any of the Work is found to be not in accordance with the requirements of the Contract Documents, including failure to perform for its intended purpose, Contractor will correct it promptly after receipt of written notice from Intermountain to do so unless Intermountain has previously given Contractor a written acceptance of such condition. The period of one year will be extended with respect to portions of the Work first performed after Substantial Completion by the period of time between Substantial Completion and the actual performance of the Work. This obligation of Contractor under this Paragraph 9.4.2 will be operative notwithstanding the acceptance of the Work under the Contract, the final certificate of payment, partial or total occupancy and/or termination of the Contract. Intermountain will give notice of observed defects with reasonable promptness, however, failure to give such notice will not relieve Contractor of its obligation to correct the Work at the cost that Contractor would have incurred if Intermountain did so report with reasonable promptness. All corrected Work will be subject to a one-year guaranty period the same in all respects as the original Work, except that such guaranty period will commence from the time of Substantial Completion of the corrected Work. This guaranty period does not affect Intermountain's right to pursue any available remedies against Contractor.

9.4.3 Removal of Work.

- a. Contractor will promptly remove from the premises all Work that Intermountain and/or A/E determines as being in nonconformance with the Contract Documents, whether incorporated or not.
- b. Contractor will promptly replace and re-execute the Work in accordance with the Contract Documents and without expense to Intermountain.
- c. Contractor will bear the expense of correcting destroyed or damaged construction, whether completed or partially completed, of Intermountain or of other contractors destroyed or damaged by such removal or replacement.
- d. If Contractor does not remove such rejected Work within a reasonable time, fixed by written notice, Intermountain may have the materials removed and stored at the expense of Contractor.
- e. If Contractor does not correct the nonconforming Work within a reasonable time, fixed by written notice, Intermountain may correct it in accordance with Paragraph 12.2.2 of these General Conditions.

9.4.4 Not Limit Other Obligations. Nothing contained in this Article 9.4 will be construed to establish a period of limitation with respect to other obligations which Contractor may have under the Contract Documents. Establishment of the time period of one year as described in Paragraph 9.4.2 relates only to the specific obligation of Contractor to correct the Work, and has no relationship to the time within which the obligation to comply with the Contract Documents may be sought to be enforced, nor to the time within which proceedings may be commenced to establish Contractor's liability with respect to Contractor's obligations other than specifically to correct the Work.

9.5 Additional Warranties.

9.5.1 In General. In addition to any other provisions of this Article 9, the following warranties will apply:

- a. Contractor warrants to Intermountain that materials and equipment furnished under the Contract will be of good quality and new, except to the extent otherwise required or expressly permitted by the Contract Documents.
- b. Contractor also warrants to Intermountain that the Work will be free from defects not inherent in the quality required or permitted and that the Work will conform to the requirements of the Contract Documents. Work not conforming to these requirements, including substitutions not properly approved and authorized, may be considered Defective at Intermountain's option.

9.5.2 Correction of Work.

- a. Contractor will promptly correct any portion of the Work which is rejected by A/E, the inspector, or Intermountain, or which fails to conform to the requirements of the Contract Documents, whether observed before or after Substantial Completion and whether or not fabricated, installed, or completed. Contractor will bear the cost of correcting such rejected Work, including additional testing and inspection costs, compensation for A/E's services, and any other expenses made necessary thereby. Such costs will in no way be payable by Intermountain and will not increase the Contract Sum.
- b. Contractor will remedy any Defects due to faulty materials, equipment, or workmanship which appear within a period of one (1) year from the date of Substantial Completion or within such longer period of time as may be prescribed by law or by the terms of any applicable special warranty required by the Contract Documents. Contractor will pay all costs of correcting faulty work, including additional A/E fees, attorney fees, expert fees, consultant fees, copy costs, and other expenses when incurred. Such costs will in no way be payable by Intermountain and will not increase the Contract Sum.

- c. Nothing in the Contract Documents will be construed to establish a period of limitation within which Intermountain may enforce the obligation of Contractor to comply with the Contract Documents. The one (1) year period specified in paragraph 9.5.2(2) has no relationship to the time within which Intermountain may enforce compliance with the Contract Documents, nor to the time within which proceedings may be commenced to establish Contractor's liability with respect to Contractor's obligations.

9.5.3 Exclusion. Unless due to the negligent or intentional act or omission of Contractor or those under Contractor's control, or as otherwise stated in the Contract Documents, Contractor's guaranty excludes remedy for damage or defect caused by abuse, modifications not executed by Contractor, improper or insufficient maintenance, improper operation, or normal wear and tear under normal usage.

9.5.4 Furnish Evidence on Request. If requested by A/E or Intermountain, Contractor will furnish satisfactory evidence as to the type and quality of materials and equipment.

9.6 Acceptance of Nonconforming Work. If Intermountain prefers to accept Work which is not in accordance with the requirements of the Contract Documents, Intermountain may do so in writing instead of requiring its removal and correction, in which case the Contract Sum will be reduced as appropriate and equitable. Such adjustment will be effected whether or not final payment has been made. Without limitation, usage by Intermountain or A/E of mechanical devices, machinery, apparatus, equipment, or other work or materials supplied under the Contract Documents before written acceptance by Intermountain, will not constitute Intermountain's acceptance.

10. INSURANCE AND BONDS.

10.1 Insurance. To protect against liability, loss and/or expense arising in connection with the performance of services described under the Contract Documents, Contractor will obtain and maintain in force as set forth below in section 10.1.9 without interruption, the following stated insurance, in a form and content satisfactory to Intermountain, from insurance companies authorized to do business in the State in which the Project is located with an A.M. Best's Rating of A- or better and Class VII or better. Contractor will require all Subcontractors to have and maintain similarly required policies. All of the following listed insurance coverages will be provided by Contractor.

10.1.1 Contractor's Commercial General Liability Insurance. Contractor will maintain coverage, with ISO Form CG 00 01 or other policy form satisfactory to Intermountain, on an occurrence basis, including coverage for Premises-Operations, Independent Contractors' Protective, Products-Completed Operations, Contractual Liability, Personal Injury, and Broad-Formed Property Damage (including coverage for Explosion, Collapse, and Underground hazards), which will provide primary coverage to the additional insureds (Intermountain and the A/E) in the event of any occurrence, claim, or suit, with per occurrence and annual aggregate policy limits of at least as follows:

\$2,000,000	General Aggregate;
\$2,000,000	Products-Completed Operations Aggregate;
\$1,000,000	Personal and Advertising Injury;
\$1,000,000	Each Occurrence.

Intermountain reserves the right to require additional coverage limits of liability from that stated above. Intermountain also reserves the right to require project specific insurance, and if such right has been exercised it will be indicated in the Contract Documents.

10.1.2 Excess and Umbrella Liability Insurance. Contractor will maintain excess and liability insurance with coverage at least as broad as the underlying liability insurance described in this section, written on an occurrence basis with per occurrence and annual aggregate policy limits based on the following chart, unless modified by mutual agreement of the parties,

Small Project (\$2,000,000 or less)
Minimum Commercial General Liability Coverage
\$1,000,000 each occurrence,
\$3,000,000 general aggregate

Medium Project (\$2,000,001 to \$10,000,000)
Minimum Commercial General Liability Coverage
\$5,000,000 each occurrence,
\$10,000,000 general aggregate

Large Project (Greater than \$10,000,000)
Minimum Commercial General Liability Coverage
\$10,000,000 each occurrence,
\$20,000,000 general aggregate

For insurance purposes, the size of the Project will be specified in the Contractor's Agreement. Such excess or umbrella liability policy will follow form with the primary liability policies, and contain a drop-down provision in case of impairment of underlying limits.

- 10.1.3 Workers' Compensation Insurance and Employers' Liability Insurance. Worker's Compensation Insurance will cover full liability under the Worker's Compensation Laws of the jurisdiction in which the Project is located at the statutory limits required by this jurisdiction's laws. Contractor will also maintain Employer's Liability Insurance with limits of at least \$1,000,000 each accident, \$1,000,000 for bodily injury by accident, and \$1,000,000 each employee for injury by disease. Contractor will collect and keep on-file evidence that Contractor and all tiers of Subcontractors have current certificates of this Workers Compensation Insurance (as required by State statute) as well as Employer's Liability Insurance, and will produce them upon request by Intermountain.
- 10.1.4 Automobile. Automobile liability insurance for claims arising from the ownership, maintenance, or use of a motor vehicle. The insurance will be written on an "occurrence" form and will apply to "any auto" and will cover all owned, non-owned, and hired automobiles used in connection with the work, with the following minimum limits of liability: \$1,000,000 – Combined Single Limit Bodily Injury and Property Damage per Occurrence.
- 10.1.5 Pollution Liability Insurance. Pollution Liability Insurance covering Contractor's or appropriate Subcontractor's liability for bodily injury, property damage and environmental damage resulting from sudden, accidental, and gradual pollution and related cleanup costs incurred by Contractor, all arising out of the goods delivered or Work and services performed (including transportation risk) under this Contract, is required with limits of at least \$1,000,000 per claim and \$1,000,000 annual aggregate.
- 10.1.6 Aircraft Use. Contractor using its own manned or unmanned aircraft, or employing manned or unmanned aircraft in connection with the work performed under the Contract Documents will maintain Aircraft Liability Insurance with a combined single limit of not less than \$1,000,000 per occurrence. This certificate will state that the policy required by this paragraph has been endorsed to name Intermountain as an Additional Insured.
- 10.1.7 Policy Aggregate(s). Unless project specific insurance is required by Intermountain, the above insurance coverages will be written or endorsed under a policy to have general, per occurrence, and aggregate limits of liability applicable to this project only.
- 10.1.8 Certificates. Before the Contract Documents are executed, Contractor will submit certificates in form and substance satisfactory to Intermountain as evidence of the insurance requirements of this Article 10. Contractor will obtain copies of Additional Insured (Ongoing and Completed Operations), Waiver of Subrogation, and Primary and Non-Contributory Endorsements and/or policy clauses. The certificates will contain provisions that no cancellation, or non-renewal will become effective except upon thirty (30) Days prior written notice by US Mail to Intermountain as evidenced by return receipt, certified mail sent to Intermountain. Contractor will notify Intermountain within thirty (30) Days of

any claim(s) against Contractor which singly or in the aggregate exceed 20% of the applicable required insured limits and Contractor will, if requested by Intermountain, use its best efforts to reinstate the policy within the original limits and at a reasonable cost. Intermountain will be named as an additional insured party, as primary coverage and not contributing, on all the insurance policies required by this Article, except the professional liability and workers' compensation policies, by endorsements satisfactory to Intermountain -- using a combination of ISO forms CG 20 10 (07/04), Additional Insured – Owners, Lessees or Contractors – Scheduled Person or Organization and CG 20 37 (07.04) Additional Insured – Owners, Lessees or Contractors – Completed Operations, or other forms acceptable to Intermountain, naming Intermountain and A/E as additional insureds. Intermountain reserves the right to request Contractor to provide a loss report from its insurance carrier. Contractor will collect and keep on-file evidence that Contractor and each Subcontractor has current certificates of Commercial General Liability Insurance, Excess /Umbrella Liability Insurance, and other insurance required herein, and will produce them upon request by Intermountain.

- 10.1.9 Maintain throughout Contract Documents Term. Contractor will maintain, from commencement of the Work, insurance coverage required in Articles 10.1 and 10.2 as follows:
- a. Commercial General Liability Insurance through expiration of the statute of limitations/repose for completed operations, but in no event less than ten (10) years from completion of the Project; and
 - b. All other insurance through final payment.
- 10.1.10 Waivers of Subrogation. Contractor waives all rights against Intermountain and other additional insureds for recovery of damages to the extent the losses and damages are covered by existing insurance, including without limitation commercial general liability, commercial excess/umbrella liability, business auto liability, workers compensation or employer's liability insurance, and pollution liability insurance. Contractor will ensure that all insurance policies required herein will be endorsed to include waivers of subrogation in favor of Intermountain. Contractor hereby waives all rights of subrogation against Intermountain.
- 10.1.11 Excess Coverages. Any type of insurance or any increase of limits of liability not described in the Contract Documents which Contractor requires for its own protection or on account of any statute, rule or regulation, will be its own responsibility and at its own expense.
- 10.1.12 Not Relieve Contractor of Liability. The carrying of any insurance required by the Contract Documents will in no way be interpreted as relieving Contractor of any other responsibility or liability under the Contract Documents or any applicable law, statute, rule, regulation, or order.
- 10.1.13 Contractor Compliance with Policies. Contractor will not violate or permit to be violated any of the provisions of the insurance policies required under the Contract.
- 10.1.14 Deductible Liability. Any and all deductibles in the above described policies will be assumed by, for the account of, and at the sole risk of Contractor. The allowable deductible for any of the Contractor insurance policies required by these General Conditions shall be no less than \$1,000 or 0.1 percent of the Contract Amount, whichever is greater.

10.2 "Builder's Risk" Property Insurance.

- 10.2.1 In General. Intermountain will provide through Substantial Completion "Builder's Risk" property insurance for the cost of the Project. The policy will be written on an all risk basis, with exclusions standard for the insurance industry, on policy forms currently and commercially available, with insurance carriers selected by Intermountain.
- 10.2.2 Deductible. The above described "Builder's Risk" policies shall be subject to a total deductible of \$5,000 per loss occurrence, which deductible shall be assumed by Contractor or Subcontractors, in proportion to their share of the total amount of an insured loss occurrence.

- 10.2.3 Waiver. To the extent damages are covered by the above described “Builder’s Risk” policies, Contractor, including all Subcontractors and Material Suppliers, and Intermountain hereby waive all rights against each other for damages caused by perils insured against under the “Builder’s Risk” insurance provided. Contractor will require similar waivers from each of their contractors, subcontractors, material suppliers, sub-consultants and agents, at any tier.
- 10.2.4 Policy Terms. Intermountain will provide a copy of the terms and conditions of the builders risk policy to Contractor upon Contractor’s request. Contractor will comply with terms, conditions, and deadlines of the builders risk policy. The terms, conditions, and deadlines of the builders risk policy shall govern coverage. Contractor will cooperate with Intermountain and the builders risk commercial insurer in the investigation, documentation, and settlement of loss claims, including without limitation promptly responding to all requests for information and documentation from the builders risk commercial insurer and/or Intermountain.
- 10.2.5 Special Hazards. Intermountain will bear the risk of loss, delay and/or damage due to earthquake and/or flood and may either insure or self-insure that risk.

10.3 Performance Bond and Payment Bond. If required by the Contract Documents, Contractor will before commencement of the Work or within ten (10) Days after signing the Agreement, whichever is earlier, submit and maintain in full force and effect as required by law and the Contract Documents, as part of the Construction Costs for the Project, written on Form AIA Document A312 (1984) or on other forms provided by Intermountain, and include as part of the quoted total all costs involved in securing and furnishing, a performance bond and a labor and material payment bond the bonds listed below, based on the completed cost of the Contract and effective upon execution of the Contract. These bonds will be from a surety company or companies licensed in the state in which the Project is located and holding valid certificates of authority under Sections 9304 to 9308, Title 31, of the United States Code as acceptable sureties or reinsurance companies on federal bonds, have a penal sum obligation not exceeding the authorization shown in the current revision of Circular #570 as issued by the United States Treasury Department, i.e. “Treasury List”, and be accompanied by a certified copy of the power of attorney stating the authority of the attorney-in-fact executing the bonds on behalf of the surety.

- a. A full 100 percent performance bond covering the faithful execution of the Contract in accordance with the Contract Documents; and
- b. A full 100 percent payment bond covering payment of all obligations arising under the Contract Documents, for the protection of each person supplying labor, service, equipment, or material for the performance of the Work.

All Subcontractor performance and payment bonds will name Contractor and Intermountain as Obligee. Intermountain reserves the right to reject any surety company, performance bond, or labor and material payment bond with or without cause.

10.4 Intermountain Self-Insurance. Intermountain may, at its option, satisfy any insurance requirements applicable to Intermountain through its self-insurance and risk management program.

11. MISCELLANEOUS PROVISIONS.

11.1 A/E’s Responsibilities. These General Conditions are not intended to provide an exhaustive or complete list of A/E’s responsibilities. A separate agreement between Intermountain and A/E incorporates these General Conditions by reference and includes additional design responsibilities.

11.2 Successors and Assigns. Intermountain and Contractor respectively bind themselves, to the other party in respect to covenants, agreements and obligations contained in the Contract Documents. Contractor will not assign the Contract, or any of its rights or obligations under the Contract, without the prior written consent of Intermountain, nor will Contractor assign any amount due or to become due as well as any rights under the Contract, without prior written consent of Intermountain. Intermountain may assign the

Contract to an institutional lender providing financing for the Project. In such event, the lender will assume Intermountain's rights and obligations under the Contract. Contractor will execute all consents reasonably required to facilitate such assignment.

11.3 Written Notice. Written notice will be deemed to have been duly served if (a) delivered in person to the individual or a member of the firm or entity or to an officer of the corporation for which it was intended, or (b) delivered at or sent by registered or certified mail, return receipt requested, or (c) deposited for delivery with a nationally recognized overnight courier service, to the last business address known to the party giving notice.

11.4 Rights and Remedies.

11.4.1 Not Limit. Duties and obligations imposed by the Contract Documents and rights and remedies available thereunder will be in addition to and not a limitation of duties, obligations, rights and remedies otherwise imposed or available by law.

11.4.2 Not Waiver. Except as expressly provided elsewhere in the Contract Documents, no action or failure to act by Intermountain, A/E or Contractor will constitute a waiver of a right or duty afforded them under the Contract Documents, nor will such action or failure to act constitute approval or acquiescence in a breach thereunder, except as any of the above may be specifically agreed to in writing. In no case will Contractor or any Subcontractors be entitled to rely upon any waiver of any of these General Conditions unless agreed to in writing by Intermountain.

11.5 Use of Intermountain Forms. Unless otherwise specifically identified in the Contract, all references or requirements for use or submission of documents to Intermountain, to A/E, or to others must be on Intermountain's approved forms. These forms include, without limitation, pay application, requests for payment, proposed change orders, change orders, modifications, requests for information, continuation sheets, waiver and lien releases, verifications, and other project related documents. Notwithstanding, Intermountain may in its sole discretion accept alternate forms. However, Intermountain's acceptance of an alternate form in one instance does not waive or modify the requirements herein for subsequent submissions.

11.6 Governing Law, Jurisdiction and Venue. To the maximum extent permitted by law, Utah laws, excluding its conflict-of-law provisions, govern the Contract and both Intermountain and Contractor submit to the exclusive jurisdiction and venue of state and federal courts located in Salt Lake County, Utah.

11.7 Interpretation. In the interest of brevity, the Contract Documents frequently omit modifying words such as "all" and "any" and articles such as "the" and "an", but the fact that a modification or an article is absent from the statement and appears in another is not intended to affect the interpretation of either statement.

11.8 Severability. The invalidity of any part, paragraph, subparagraph, phrase, provision or aspect of the Contract documents will not impair or affect in any manner the validity, enforceability or effect of the remainder of the Contract Documents.

11.9 Construction of Words. Unless otherwise stated in the Contract Documents, words, which have well-known technical or construction industry meanings, will be construed as having such recognized meanings. Unless the context requires otherwise, all other technical words will be construed in accordance with the meaning normally established by the particular, applicable profession or industry. All other words, unless the context requires otherwise, will be construed with an ordinary, plain meaning.

11.10 No Third-Party Rights. The Contract Documents will not be construed to create a contractual relationship of any kind (1) between A/E and Contractor, (2) between Intermountain and a Subcontractor or (3) between any persons or entities other than Intermountain and Contractor. Nothing contained herein will be deemed as creating third party beneficiary contract rights or other actionable rights or duties as

between Contractor and A/E, or as between Intermountain, Contractor, or A/E on the one hand, and any other person or entity.

- 11.11 Change of Control.** If a third party acquires a controlling interest (i.e., 50% ownership or more) of Contractor, then (a) Contractor will notify Intermountain within fifteen (15) Days of that acquisition, and (b) upon that acquisition, Intermountain may terminate for cause the Contract immediately upon written notice to Contractor.
- 11.12 Entire Agreement and Amendment Limitation.** The Contract represents the entire and integrated agreement between Intermountain and Contractor and supersedes all prior negotiations, representations or agreements, either written or oral. The Contract may be amended or modified only by (1) a written amendment executed by both Intermountain and Contractor, or (2) by a Modification.
- 11.13 Notices.** Any notice required by the Contract will be served upon the recipient's designated representative by hand delivery at the last known business address, or by mail or nationally recognized overnight courier service with "delivery confirmation" to the last known address.
- 11.14 No Publicity.** Without receiving prior written approval from an Intermountain vice president, Contractor will not distribute any publicity regarding the Contract.
- 11.15 Waivers.** No waiver by Intermountain or Contractor of any default will constitute a waiver of the same default at a later time or of a different default.
- 11.16 Waiver of Consequential Damages.** Intermountain and Contractor waive all claims against each other for any consequential damages that may arise out of or relate to the Contract. Intermountain waives damages including but not limited to is loss of use of the Project, any rental expenses incurred, loss of income, profit, or financing related to the Project, loss of business, the services of employees, or loss of reputation. Contractor waives damages including but not limited to the loss of business, loss of financing, principal office overhead and expenses, loss of profits not related to this Project, loss of bonding capacity or loss of reputation. This section may not be construed to preclude recovery of consequential damages when such damages are actually recovered from insurance policies required by the Contract Documents. The provisions of this section also apply to the termination of the Contract and survive such termination.
- 11.17 Compliance.**
- 11.17.1 Remuneration. Remuneration flowing between the parties is at fair market value for actual and necessary items furnished or services rendered, is based upon an arm's-length transaction, and does not take into account, directly or indirectly, the value or volume of any past or future referral or other business generated between the parties (or of any referral or business of any principal, affiliate, or immediate family member - as those terms may be defined by applicable laws - of either party).
- 11.17.2 Financial Relationships. To its knowledge, Contractor (a) is not a physician-owned entity and (b) has no prohibited financial relationship with any physician who is in a position to generate business for Intermountain, or with an immediate family member of that physician. Intermountain defines a "physician-owned entity" as any entity in which a physician, or immediate family member of a physician, holds an ownership, investment, or royalty interest (if royalties are paid on any purchase resulting from the royalty holder's order). The Code of Federal Regulations (CFR) defines "financial relationship" (in 42 CFR 411.354) and "immediate family member" (in 42 CFR 411.351).
- [Note: Physicians and their immediate family members may own investment securities of Contractor if that investment complies with 42 CFR 411.356(a) or (b), and may have a compensation arrangement that both complies with 42 CFR 411.357(p) and does not take into account the volume or value of referrals or other business generated for Intermountain by a physician or a physician's immediate family members.]

- 11.17.3 Exclusion or Sanction. Contractor warrants that neither it, or any of its affiliates or employees, excluded from participation in, or sanctioned under, any state or federal healthcare program, including those set forth in 42 U.S.C. §1320a 7b(f). Contractor will notify Intermountain immediately in writing if the warranty in the preceding sentence is, or becomes, inaccurate during the Term.
- 11.17.4 Access to Books and Records. Intermountain is a provider under Federal Medicare programs and is subject to Section 952 of the Omnibus Reconciliation Act of 1980. That law requires Intermountain, as a provider, to include the following provision in its agreements with suppliers who receive \$10,000 or more under an agreement with Intermountain. If requested by the Secretary of HHS, by the U.S. Comptroller, or by an authorized representative of either of them, Contractor will make available to the requestor the Contract and Contractor's books, documents, and records to allow the requestor to certify the nature and extent of the charges for services provided under the Contract and charged to Medicare. Contractor will continue to make those items available for four years after Contractor furnishes the final products (or services) under the Contract. If Contractor contracts with another to carry out any of Contractor's duties under the Contract and the Subcontractor is to receive \$10,000 or more in value under that subcontract, then Contractor will obtain a written contractual commitment from the Subcontractor to comply with the obligations of this section of the Agreement. The obligations of this Section survive the expiration or other termination of the Contract.
- 11.17.5 Code of Ethics. In its dealings with Intermountain, Contractor has and will comply with all codes of ethics applicable to suppliers and their interactions with purchasers like Intermountain, including, without limitation, the AdvaMed Code of Ethics on Interactions with Health Care Professionals.
- 11.17.6 Facility Access Policy. All of Contractor's representative(s) entering any Intermountain facility must comply with Intermountain's Facility Access Policy. This policy requires each of these Contractor representatives to check in with Intermountain on each visit to an Intermountain facility to receive an identification badge; and as applicable, log onto: <https://intermountainhealthcare.org/supply-chain-organization/for-suppliers/for-current-suppliers/access-to-intermountain-facilities/> and complete the registration requirements. Please contact Intermountain representative with any questions.
- 11.17.7 Equal Opportunity. Affirmative Action. Intermountain is an equal opportunity employer and federal contractor. Consequently, the parties agree that, to the extent applicable, they will comply with the following, which are incorporated herein by reference: 41 CFR 60 1.4(a), 41 CFR 60 300.5(a), 41 CFR 60 741.5(a), and Executive Order 13496 (29 CFR Part 471, Appendix A to Subpart A), relating to the notice of employee rights under federal labor laws, specifically:
- a. Intermountain and Contractor will abide by the requirements of 41 CFR 60 300.5(a), as applicable. This regulation prohibits discrimination against qualified protected veterans, and requires affirmative action by covered prime contractors and Subcontractors to employ and advance in employment qualified protected veterans.
 - b. Intermountain and Contractor will abide by the requirements of 41 CFR 60 741.5(a), as applicable. This regulation prohibits discrimination against qualified individuals on the basis of disability, and requires affirmative action by covered prime contractors and Subcontractors to employ and advance in employment qualified individuals with disabilities.
- 11.17.8 Remedies. If Contractor breaches any obligation of this section, Intermountain may immediately terminate for cause the Contract upon written notice to Contractor.
- 11.18 Work Restrictions / Drug Testing**. Contractor will ensure that Contractor, its agents, employees, and all Subcontractors do not use or consume alcohol or cannabis, or illegally use drugs, upon Intermountain's property or enter upon or perform any work on Intermountain's property while under their influence. Contractor will obtain necessary consents and will conduct periodic inspections and drug testing to monitor and ensure compliance with these requirements. Contractor will bear the expenses of such inspections and drug testing and will hold Intermountain harmless from all claims arising out of or relative thereto. In addition, Contractor will ensure that Contractor and all Subcontractors do not smoke or vape

anything upon Intermountain's property except and only within designated smoking areas approved by Intermountain.

11.19 Utah State Sales Tax. Contractors should be exempt on purchases of material installed or converted into real property to be used by Intermountain. The Contractor will furnish each vendor with Intermountain's Tax exemption number.

11.20 Notice of Intent to Obtain Final Completion. Contractor shall file with the Utah State Construction Registry, on its own behalf and/or on behalf of Intermountain, a notice of intent to obtain final completion at least forty-five (45) Days before the day on which Intermountain or Contractor files or could file a notice of completion under Utah statutes if: (1) the completion of performance time under the original contract for construction work is greater than one hundred twenty (120) Days; (2) the total original construction contract price exceeds \$500,000; and (3) neither Contractor nor Intermountain has obtained a payment bond in accordance with Utah Code Ann. Section 14-2-1.

11.21 Notice of Completion. Within five (5) Days of final completion of the Project and in compliance with Section 38-1a-507 Utah Code Annotated, Contractor shall file with the Utah State Construction Registry, and copy to Intermountain, a notice of completion which shall include, without limitation, the following:

- a. The name, address, telephone number, and email address of the person filing the notice of completion;
- b. The name of the county in which the Project and/or Project site is located;
- c. The date on which final completion is alleged to have occurred;
- d. The method used to determine final completion; and
- e. One of the following:
 1. The tax parcel identification number of each parcel included in the Project and/or Project site;
 2. The entry number of a preliminary notice on the same project that includes the tax parcel identification number of each parcel included in the Project and/or Project site; or
 3. The entry number of the building permit issued for the Project.

Notwithstanding any other provision of the Contract Documents to the contrary, Contractor and Intermountain agree that any breach or failure to comply with this requirement by Contractor will constitute a breach of contract and the Contractor will be liable for any direct, indirect, or consequential damages to Intermountain flowing from this breach.

11.22 Audit Rights. Contractor will keep, maintain and preserve complete, current and accurate books, records, and accounts of the transactions contemplated by this Agreement and such additional books, records and accounts as are necessary to establish and verify Contractor's compliance with the Contract. All these books, records and accounts will be available for inspection and audit by Intermountain and/or an independent third party designated by Intermountain and approved by Contractor at any time during the Term and for two (2) years thereafter, but only during reasonable business hours and upon reasonable notice. In addition:

- a. Intermountain agrees that its routine audits will not be conducted more frequently than once in any consecutive twelve (12) month period.
- b. If, after any audit of Contractor, Intermountain requires additional information regarding the transactions contemplated by the Contract, Contractor will furnish to Intermountain or to the third-party audit firm any additional information Intermountain specifies that relates to the audit period to establish and verify Contractor's compliance with the Contract Documents.

- c. Intermountain's right to inspect and audit is without prejudice to any other or additional rights or remedies of either party.
- d. Contractor agrees to not unreasonably withhold approval of any independent third-party audit firm.
- e. If an audit reveals an overcharge incurred by Intermountain on this Project, Contractor will provide a written response explanation, correct any error and remit any monies due within ten (10) Days after receiving notice of the error or overcharge.

Intermountain may audit applications for payments or any other aspect of the Services and Work of Contractor and of the Subcontractor or suppliers at any tier. Contractor will cooperate with Intermountain in providing all necessary information for any Intermountain audit.

12. TERMINATION OR SUSPENSION OF THE CONTRACT.

12.1 Termination by Contractor.

12.1.1 In General. If the Work is stopped for a period of ninety (90) Days through no act or fault of Contractor or a Subcontractor, or their agents or employees or any other persons performing portions of the Work under contract with any of the above, Contractor, may terminate the Contract in accordance with 12.1.2 herein below for any of the following reasons:

- a. Because Intermountain has persistently failed to fulfill fundamental Intermountain's obligations under the Contract Documents with respect to matters important to the progress of the Work;
- b. Issuance of an order of a court or other public authority having jurisdiction which necessitates such termination, except that where Contractor has standing, Contractor must cooperate in efforts to stay and/or appeal such order;
- c. A governmental declaration of national emergency, making material unavailable; or
- d. Unavoidable casualties or other similar causes as listed in Paragraph 12.2.2(2) herein below.

12.1.2 Notice. If one of the reasons for termination in Paragraph 12.1.1 hereinabove exist, Contractor may, upon ten (10) additional Days' written notice to Intermountain and A/E, and such condition giving cause for termination still not cured, terminate the Contract and recover from Intermountain payment for Work executed and for proven loss with respect to materials, equipment, tools, and construction equipment and machinery, including reasonable overhead, profit and damages associated only with work completed before the notice of termination.

12.2 Termination by Intermountain for Cause.

12.2.1 In General. Intermountain may terminate the Contract if Contractor fails to cure any of the following within a period of ten (10) Days (or longer if Intermountain so approves in writing) after receipt of notice from Intermountain specifying the cause for termination:

- a. Contractor refuses or fails to supply enough properly skilled workers or proper materials;
- b. Contractor fails to make payment to Subcontractors for materials or labor in accordance with the respective agreements between Contractor and the Subcontractors;
- c. Contractor disregards laws, ordinances, or rules, regulations, resolutions or orders of a public authority having jurisdiction; or
- d. Contractor fails to perform the Work within the time specified in the Contract Documents or any authorized extension thereof or Contractor fails to make progress with the Work as to endanger such compliance;
- e. Contractor fails to perform the Work or is otherwise in breach of a provision of the Contract Documents;

- f. Contractor fails to respond promptly to the financial responsibility inquiry herein;
 - g. As permissible by law for a reason to terminate, Contractor is adjudged bankrupt;
 - h. As permissible by law for a reason to terminate, Contractor should make a general assignment for the benefit to creditors;
 - i. As permissible by law for a reason to terminate, Contractor has or should have a receiver appointed on account of Contractor's insolvency; or
 - j. Contractor fails to follow the material safety requirements and precautions either as expressly provided in the Contract Documents or as consistent with the customary practices in the industry.
- 12.2.2 Intermountain's Right to Carry Out the Work. If Contractor defaults or neglects to carry out the Work in accordance with the Contract Documents and fails within a ten (10) Day period (or longer if approved by Intermountain in writing) after receipt of written notice from Intermountain to cure such default or neglect, Intermountain may without prejudice to other remedies Intermountain may have, correct such deficiencies, including taking over the Work and prosecuting the same to completion, by contract or otherwise, and may take possession of, and utilize in completing the Work, such materials, appliances, and facilities as may be on the site of the Work as well as the site as necessary for its proper completion. In such case, Intermountain will offset from payments then or thereafter due Contractor the cost of correcting such deficiencies, including compensation for A/E, Intermountain's staff and legal counsel's additional services and expenses made necessary by such default, neglect or failure. If payments then or thereafter due Contractor are not sufficient to cover such amounts, Contractor will pay the difference to Intermountain. Contractor will continue performance of the Contract to the extent not terminated.
- 12.2.3 Items Required to Be Transferred or Delivered. Intermountain may require Contractor to transfer title and deliver to Intermountain, in the manner and to the extent directed by Intermountain:
- a. Any completed portion of the Work; and
 - b. Any partially completed portion of the Work and any parts, tools, dies, jigs, fixtures, drawings, information, and contract rights (hereinafter called "construction materials") as Contractor has specifically produced or specifically acquired for the performance of such part of this Contract as has been terminated; and Contractor will, upon direction of Intermountain, protect and preserve property in the possession of Contractor in which Intermountain has an interest.
- 12.2.4 Payment. When Intermountain terminates the Contract for one or more of the reasons stated in Paragraph 12.2.1, Intermountain may withhold payment and/or pursue all available remedies.
- 12.2.5 Intermountain Protection If Lienable. When the subject property is lienable, Intermountain may withhold from amounts otherwise due Contractor for such completed Work or construction materials such sum as Intermountain determines to be necessary to protect Intermountain against loss because of outstanding liens or claims for former lien holders.
- 12.2.6 Credits and Deficits. If the unpaid balance of the Contract Sum exceeds the full cost of finishing the Work, including compensation for A/E's services and expenses made necessary thereby, such excess will be paid to Contractor. If such cost exceeds the unpaid balance, Contractor will pay the difference to Intermountain this obligation for payment will survive the termination of the Contract.
- 12.2.7 If Contractor Found Not in Default or Excusable. If, after notice of termination of the Contract under the provisions of this Article, it is determined for any reason that Contractor was not in default under the provisions of this Article, or that the default was excusable under the provisions of this Article, the rights and obligations of the parties will be the same as if the notice of termination had been issued pursuant to the termination for convenience provisions.

- 12.2.8 Rights and Remedies Not Exclusive. The rights and remedies of Intermountain provided in this Article 12.2 will not be exclusive and are in addition to any other rights and remedies provided by law or under this Contract.

12.3 Suspension, Delay or Interruption of Work by Intermountain for Convenience.

- 12.3.1 By Intermountain in Writing. Intermountain may in writing and without cause, order Contractor to suspend, delay or interrupt the Work in whole or in part for such period of time as Intermountain may determine to be appropriate for the convenience of Intermountain.
- 12.3.2 Adjustments. Any adjustment in Contract Sum and Contract Time will be in accordance with Articles 3, 4, and 7.

12.4 Termination for Convenience of Intermountain.

- 12.4.1 In General. The performance of Work under this Contract may be terminated by Intermountain in accordance with this Article 12.4 in whole, or from time to time, in part, whenever Intermountain will determine that such termination is in the best interest of Intermountain or any person for whom Intermountain is acting under this Contract. Any such termination will be effected by delivery to Contractor of a notice of termination specifying the extent to which performance of Work under the Contract is terminated, and the date upon which such termination becomes effective.
- 12.4.2 Contractor Obligations. After receipt of a notice of termination, and except as otherwise directed by Intermountain in writing, Contractor will:
- a. Stop work under the Contract on the date and to the extent specified in the notice of termination;
 - b. Place no further orders or subcontracts for materials, services or facilities, except as may be necessary for completion of such portion of the Work under the Contract as is not terminated;
 - c. Terminate all orders and subcontracts to the extent that they relate to performance of Work terminated by the notice of termination;
 - d. Assign to Intermountain in the manner, at the times, and to the extent directed by Intermountain, all of the right, title and interest of Contractor under the orders and subcontracts so terminated, in which case Intermountain will have the right, in its discretion, to settle or pay any or all claims arising out of the termination of such orders and subcontracts;
 - e. Settle all outstanding liabilities and all claims arising out of such termination of orders and subcontracts, with the approval or ratification of Intermountain, which approval or ratification will be final for all the purposes of this Article 12.4;
 - f. Transfer title and deliver to Intermountain in the manner, at the times, and to the extent, if any, directed by Intermountain:
 - (i) The fabricated or unfabricated parts, work in process, completed work, supplies, and other material produced as a part of, or acquired in connection with the performance of the Work terminated by the notice of termination; and
 - (ii) The completed or partially completed drawings, information, and other property which, if the Contract had been completed, would have been required to be furnished to Intermountain;
 - g. Use best efforts to sell, in the manner, at the times, to the extent, and at the price or prices directed or authorized by Intermountain, any property of the types referred to in Paragraph 12.4.2.f above; provided, however, that Contractor:
 - (i) Will not be required to extend credit to any purchaser; and

- (ii) May acquire any such property under the conditions prescribed by and at a price or prices approved by Intermountain; and provided further that the proceeds of any such transfer of or disposition will be applied in reduction of any payments to be made by Intermountain to Contractor under this Contract or will otherwise be credited to the Contract Sum or paid in such other manner as Intermountain may direct;
 - h. Complete performance of such part of the Work as will not have been terminated by the notice of termination; and
 - i. Take such action as may be necessary, or as Intermountain may direct, for the protection and preservation of the property related to this Contract which is in the possession of Contractor in which Intermountain has or may acquire an interest.
- 12.4.3 Agreed Upon Payment. Subject to the provisions of Paragraph 12.4.2 above, Contractor and Intermountain may agree upon the amount to be paid to Contractor by reason of the total or partial termination of Work pursuant to this Article 12.4.
- 12.4.4 Payment Not Agreed Upon. In the event of the failure of Contractor and Intermountain to agree, as provided in Paragraph 12.4.3, upon the whole amount to be paid to Contractor by reason of the termination of Work pursuant to this Article 12.4, Intermountain will pay to Contractor the portion of the Contract Sum requisite with the portion of the Work completed as determined by Intermountain as of the date of termination, subject to offsets if any.
- 12.4.5 Deductions. In arriving at the amount due Contractor under this Article 12.4, there will be deducted:
- a. All unliquidated advance or other payments on account theretofore made to Contractor, applicable to the terminated portion of this Contract;
 - b. Any Claim which Intermountain may have against Contractor in connection with this Contract; and
 - c. The agreed price for, or the proceeds of sale of, any materials, supplies, or other things acquired by Contractor or sold, pursuant to the provisions of this Article 12.4, and not otherwise recovered by or credited to Intermountain.
- 12.4.6 Partial Payments. Intermountain may, from time to time, under such terms and conditions as it may prescribe, make partial payments and payments on account against cost incurred by Contractor in connection with the terminated portion of this Contract whenever, in the opinion of Intermountain the aggregate of such payments will be within the amount to which Contractor will be entitled hereunder. If the total of such payments is in excess of the amount finally agreed or determined to be due under this Article 12.4, such excess will be payable by Contractor to Intermountain upon demand, together with interest at a rate of five percent (5%) per annum for the period until the date such excess is repaid to Intermountain; provided, however, that no interest will be charged with respect to any such excess payment attributable to a reduction in Contractor's claim by reason of retention or other disposition of termination inventory until ten (10) Days after the date of such retention or disposition, or such later date as determined by Intermountain by reason of the circumstances.
- 12.4.7 Preserve and Make Available Records. Unless otherwise provided for in this Contract, or by applicable law, Contractor will, from the effective date of termination until the expiration of three years after final settlement under this Contract, preserve and make available to Intermountain at all reasonable times at the office of Contractor, but without direct charge to Intermountain, all books, records, documents and other evidence bearing on the costs and expenses of Contractor under this Contract and relating to the Work terminated hereunder, or, to the extent approved by Intermountain Representative, photographs, micrographs, or other authentic reproductions thereof.
- 12.4.8 Intermountain's Right to Stop the Work. If Contractor fails to correct Work or fails to carry out Work, as required by the Contract Documents or fails to comply with all required and customary safety

precautions; Intermountain, by written order signed personally or by an agent specifically so empowered by Intermountain in writing, may order Contractor to stop the Work, or any portion thereof, until the cause for such order has been eliminated; however, the right of Intermountain to stop the Work will not give rise to a duty on the part of Intermountain to exercise this right for the benefit of Contractor or any other person or entity.

END OF DOCUMENT

Application and Certificate for Payment

TO OWNER:	PROJECT:	APPLICATION NO: 001	Distribution to:
		PERIOD TO:	OWNER: <input type="checkbox"/>
FROM	VIA	CONTRACT FOR:	ARCHITECT: <input type="checkbox"/>
CONTRACTOR:	ARCHITECT:	CONTRACT DATE:	CONTRACTOR: <input type="checkbox"/>
		PROJECT NOS: / /	FIELD: <input type="checkbox"/>
			OTHER: <input type="checkbox"/>

CONTRACTOR'S APPLICATION FOR PAYMENT

Application is made for payment, as shown below, in connection with the Contract. Continuation Sheet, AIA Document G703, is attached.

1. ORIGINAL CONTRACT SUM	\$0.00
2. NET CHANGE BY CHANGE ORDERS	\$0.00
3. CONTRACT SUM TO DATE (Line 1 ± 2)	\$0.00
4. TOTAL COMPLETED & STORED TO DATE (Column G on G703)	\$0.00
5. RETAINAGE:	
a. 0 _____ % of Completed Work (Column D + E on G703)	\$0.00
b. 0 _____ % of Stored Material (Column F on G703)	\$0.00
Total Retainage (Lines 5a + 5b or Total in Column I of G703)	\$0.00
6. TOTAL EARNED LESS RETAINAGE	\$0.00
(Line 4 Less Line 5 Total)	
7. LESS PREVIOUS CERTIFICATES FOR PAYMENT	\$0.00
(Line 6 from prior Certificate)	
8. CURRENT PAYMENT DUE	\$0.00
9. BALANCE TO FINISH, INCLUDING RETAINAGE	
(Line 3 less Line 6)	\$0.00

CHANGE ORDER SUMMARY	ADDITIONS	DEDUCTIONS
Total changes approved in previous months by Owner	\$0.00	\$0.00
Total approved this Month	\$0.00	\$0.00
TOTALS	\$0.00	\$0.00
NET CHANGES by Change Order		\$0.00

The undersigned Contractor certifies that to the best of the Contractor's knowledge, information and belief the Work covered by this Application for Payment has been completed in accordance with the Contract Documents, that all amounts have been paid by the Contractor for Work for which previous Certificates for Payment were issued and payments received from the Owner, and that current payment shown herein is now due.

CONTRACTOR:

By: _____ Date: _____

State of: _____

County of: _____

Subscribed and sworn to before
me this _____ day of _____

Notary Public:

My Commission expires: _____

ARCHITECT'S CERTIFICATE FOR PAYMENT

In accordance with the Contract Documents, based on on-site observations and the data comprising this application, the Architect certifies to the Owner that to the best of the Architect's knowledge, information and belief the Work has progressed as indicated, the quality of the Work is in accordance with the Contract Documents, and the Contractor is entitled to payment of the AMOUNT CERTIFIED.

AMOUNT CERTIFIED \$0.00

(Attach explanation if amount certified differs from the amount applied. Initial all figures on this Application and on the Continuation Sheet that are changed to conform with the amount certified.)

ARCHITECT:

By: _____ Date: _____

This Certificate is not negotiable. The AMOUNT CERTIFIED is payable only to the Contractor named herein. Issuance, payment and acceptance of payment are without prejudice to any rights of the Owner or Contractor under this Contract.



AIA[®] Document G703™ – 1992

Continuation Sheet

AIA Document, G702™–1992, Application and Certification for Payment, or G736™–2009, Project Application and Project Certificate for Payment, Construction Manager as Adviser Edition, containing Contractor's signed certification is attached.
 In tabulations below, amounts are in US dollars.
 Use Column I on Contracts where variable retainage for line items may apply.

APPLICATION NO:	001
APPLICATION DATE:	
PERIOD TO:	
ARCHITECT'S PROJECT NO:	

A	B	C	D		E	F	G		H	I
			WORK COMPLETED				TOTAL COMPLETED AND STORED TO DATE (D + E + F)	% (G ÷ C)		
ITEM NO.	DESCRIPTION OF WORK	SCHEDULED VALUE	FROM PREVIOUS APPLICATION (D + E)	THIS PERIOD	MATERIALS PRESENTLY STORED (NOT IN D OR E)	TOTAL COMPLETED AND STORED TO DATE (D + E + F)	%	BALANCE TO FINISH (C - G)	RETAINAGE (IF VARIABLE RATE)	
		0.00	0.00	0.00	0.00	0.00	0.00%	0.00	0.00	
		0.00	0.00	0.00	0.00	0.00	0.00%	0.00	0.00	
		0.00	0.00	0.00	0.00	0.00	0.00%	0.00	0.00	
		0.00	0.00	0.00	0.00	0.00	0.00%	0.00	0.00	
		0.00	0.00	0.00	0.00	0.00	0.00%	0.00	0.00	
		0.00	0.00	0.00	0.00	0.00	0.00%	0.00	0.00	
		0.00	0.00	0.00	0.00	0.00	0.00%	0.00	0.00	
		0.00	0.00	0.00	0.00	0.00	0.00%	0.00	0.00	
		0.00	0.00	0.00	0.00	0.00	0.00%	0.00	0.00	
		0.00	0.00	0.00	0.00	0.00	0.00%	0.00	0.00	
		0.00	0.00	0.00	0.00	0.00	0.00%	0.00	0.00	
		0.00	0.00	0.00	0.00	0.00	0.00%	0.00	0.00	
		0.00	0.00	0.00	0.00	0.00	0.00%	0.00	0.00	
		0.00	0.00	0.00	0.00	0.00	0.00%	0.00	0.00	
		0.00	0.00	0.00	0.00	0.00	0.00%	0.00	0.00	
		0.00	0.00	0.00	0.00	0.00	0.00%	0.00	0.00	
		0.00	0.00	0.00	0.00	0.00	0.00%	0.00	0.00	
		0.00	0.00	0.00	0.00	0.00	0.00%	0.00	0.00	
		0.00	0.00	0.00	0.00	0.00	0.00%	0.00	0.00	
		0.00	0.00	0.00	0.00	0.00	0.00%	0.00	0.00	
		0.00	0.00	0.00	0.00	0.00	0.00%	0.00	0.00	
		0.00	0.00	0.00	0.00	0.00	0.00%	0.00	0.00	
		0.00	0.00	0.00	0.00	0.00	0.00%	0.00	0.00	
		0.00	0.00	0.00	0.00	0.00	0.00%	0.00	0.00	
	GRAND TOTAL	\$0.00	\$0.00	\$0.00	\$0.00	\$0.00	0.00%	\$0.00	\$0.00	



AIA[®] Document G704[™] – 2017

Certificate of Substantial Completion

PROJECT: <i>(name and address)</i>	CONTRACT INFORMATION: Contract For: Date:	CERTIFICATE INFORMATION: Certificate Number: 001 Date:
OWNER: <i>(name and address)</i>	ARCHITECT: <i>(name and address)</i>	CONTRACTOR: <i>(name and address)</i>

The Work identified below has been reviewed and found, to the Architect's best knowledge, information, and belief, to be substantially complete. Substantial Completion is the stage in the progress of the Work when the Work or designated portion is sufficiently complete in accordance with the Contract Documents so that the Owner can occupy or utilize the Work for its intended use. The date of Substantial Completion of the Project or portion designated below is the date established by this Certificate.
(Identify the Work, or portion thereof, that is substantially complete.)

ARCHITECT <i>(Firm Name)</i>	SIGNATURE	PRINTED NAME AND TITLE	DATE OF SUBSTANTIAL COMPLETION
------------------------------	-----------	------------------------	--------------------------------

WARRANTIES

The date of Substantial Completion of the Project or portion designated above is also the date of commencement of applicable warranties required by the Contract Documents, except as stated below:
(Identify warranties that do not commence on the date of Substantial Completion, if any, and indicate their date of commencement.)

WORK TO BE COMPLETED OR CORRECTED

A list of items to be completed or corrected is attached hereto, or transmitted as agreed upon by the parties, and identified as follows:
(Identify the list of Work to be completed or corrected.)

The failure to include any items on such list does not alter the responsibility of the Contractor to complete all Work in accordance with the Contract Documents. Unless otherwise agreed to in writing, the date of commencement of warranties for items on the attached list will be the date of issuance of the final Certificate of Payment or the date of final payment, whichever occurs first. The Contractor will complete or correct the Work on the list of items attached hereto within () days from the above date of Substantial Completion.

Cost estimate of Work to be completed or corrected: \$

The responsibilities of the Owner and Contractor for security, maintenance, heat, utilities, damage to the Work, insurance, and other items identified below shall be as follows:
(Note: Owner's and Contractor's legal and insurance counsel should review insurance requirements and coverage.)

The Owner and Contractor hereby accept the responsibilities assigned to them in this Certificate of Substantial Completion:

CONTRACTOR <i>(Firm Name)</i>	SIGNATURE	PRINTED NAME AND TITLE	DATE
OWNER <i>(Firm Name)</i>	SIGNATURE	PRINTED NAME AND TITLE	DATE



AIA[®] Document G706A[™] – 1994

Contractor's Affidavit of Release of Liens

PROJECT: <i>(Name and address)</i>	ARCHITECT'S PROJECT NUMBER:	OWNER: <input type="checkbox"/>
TO OWNER: <i>(Name and address)</i>	CONTRACT FOR:	ARCHITECT: <input type="checkbox"/>
	CONTRACT DATED:	CONTRACTOR: <input type="checkbox"/>
		SURETY: <input type="checkbox"/>
		OTHER: <input type="checkbox"/>

STATE OF:
COUNTY OF:

The undersigned hereby certifies that to the best of the undersigned's knowledge, information and belief, except as listed below, the Releases or Waivers of Lien attached hereto include the Contractor, all Subcontractors, all suppliers of materials and equipment, and all performers of Work, labor or services who have or may have liens or encumbrances or the right to assert liens or encumbrances against any property of the Owner arising in any manner out of the performance of the Contract referenced above.

EXCEPTIONS:

SUPPORTING DOCUMENTS ATTACHED HERETO:

1. Contractor's Release or Waiver of Liens, conditional upon receipt of final payment.
2. Separate Releases or Waivers of Liens from Subcontractors and material and equipment suppliers, to the extent required by the Owner, accompanied by a list thereof.

CONTRACTOR: *(Name and address)*

BY:

(Signature of authorized representative)

(Printed name and title)

Subscribed and sworn to before me on this date:

Notary Public:

My Commission Expires:

SECTION 01 10 00 - SUMMARY

PART 1 - GENERAL

1.1 RELATED DOCUMENTS

- A. Drawings and general provisions of the Contract, including General and Supplementary Conditions and other Division 1 Specification Sections, apply to this Section.

1.2 SUMMARY

- A. This Section includes the following:
 - 1. Work covered by the Contract Documents.
 - 2. Use of premises.
 - 3. Code compliance
 - 4. Dust control
 - 5. Protection of existing improvements
 - 6. Traffic Control
 - 7. Temporary Controls

1.3 WORK COVERED BY CONTRACT DOCUMENTS

- A. Project Identification: Project consists of construction of a new outpatient ambulatory Surgery Center (ASC) in the previous shelled space on the fourth floor of the Budge Clinic at Logan Regional Hospital. The ASC will have three operating rooms, four post anesthesia care/recovery stations (PACU), eight prep and recovery bays and associated support spaces for staff and patients. The approximate square footage of the project is 11,454 sf.

- B. Total square feet 11,454 SF.

Project Location: Logan Regional Hospital
Address: 1350 North 500 East, Logan, UT 84341

- C.
 - 1. Owner: Intermountain Healthcare, 36 South State Street, 23rd Floor
Salt Lake City, Utah 84111
 - 2. Owner's Representative: Milt White, North Region Construction Director
- D. Architects: HDR Architects, 201 California Street, Suite 1500, San Francisco, CA 94111 &
NJRA Architects, 5272 College Drive, Suite 104, Murray, Utah 84123.
- E. The Work consists of the following:

1. The Work includes: architectural, structural, mechanical, plumbing and electrical work as defined on the contract documents.

1.4 USE OF PREMISES

- A. Contractor's use of premises is limited only by Owner's right to perform work or to retain other contractors on portions of Project.
- B. Assume full responsibility for the protection and safekeeping of products under this Contract, stored on the site.

1.5 CODE COMPLIANCE

- A. All work shall comply with current edition of codes including but not limited to the following:
 1. International Building Code
 2. International Mechanical Code
 3. International Plumbing Code
 4. NFPA
 5. National Electric Code
 6. OSHA Regulation
 7. Health and Safety Regulations
 8. Utility Company Regulations
 9. Police, Fire Department Rules
 10. Environmental Protection Regulations
 11. Americans with Disabilities Act
- B. Arrange for authorities having jurisdiction to inspect and test according to their requirements and for each temporary utility before use. Obtain required certifications and permits.
- C. Requirements of codes and regulations shall be considered as the minimum. Where the contract documents exceed (without violating) code and regulation requirements, contract requirements shall take precedence. Where codes conflict, the more stringent shall apply.

1.6 DUST CONTROL

Temporary partitions should be constructed as called out on the Contract Documents and as mentioned in specification Section 024119 – Selective Demolition.

1.7 PROTECTION OF EXISTING IMPROVEMENTS

- A. Take precautions necessary to protect all existing utilities, monitor wells, and other Site improvements to remain from damage due to the work of this Project.
- B. Provide restoration of damaged property if damage is a result of construction activities.

1.8 TRAFFIC CONTROL

- A. Maintain control of vehicular and pedestrian traffic caused by, or resulting from, the work of this Project.
- B. Means of control shall be in accordance with the applicable regulations of the jurisdiction responsible for traffic safety.

1.9 TEMPORARY CONTROLS

- A. Conform to all applicable state and local ordinances and regulations. Obtain and pay for necessary permits and licenses as required by local jurisdictions.

END OF SECTION

SECTION 01 29 00 – PAYMENT PROCEDURES

PART 1 - GENERAL

1.1 SUMMARY

- A. Section includes measurement and payment provisions for, but not limited to, the following:
 - 1. Materials Delivered but Not Yet Installed.
 - 2. Schedule of Values.
 - 3. Applications for Payment.
 - 4. Preliminary Progress Schedule.
 - 5. Construction Progress Schedule.
 - 6. Change Orders.

1.2 MATERIALS DELIVERED BUT NOT INSTALLED

- A. Exclude from Applications for Payment materials or equipment delivered and stored, but not yet incorporated into the Work, unless circumstances dictate acceptance (i.e. pre-purchase of equipment for early delivery to prevent delay of construction or subsequent facility opening date) and pre-payment is agreed to, in writing, by the Owner.
- B. If Owner has agreed to make early payment on account of materials or equipment not incorporated in the Work, but delivered and stored in conformance with the requirements of the Contract Documents, at the site, or at some other location agreed upon in writing, such pre-payment shall be conditioned upon approval by Contractor's Insurance Carrier, and Architect, in writing, prior to submission by Contractor of the applicable payment request.
- C. Pre-payment request shall contain substantiating documentation, including:
 - 1. Bill(s) of Sale.
 - 2. Evidence of insurance for the materials or equipment, covering the item(s) until completion of installation.
 - 3. Provision for transportation to the Project Site.
 - 4. Protection of Owner's interest under any circumstance (i.e. Owner's right to retrieve equipment or materials from storage area of a bankrupt company's property).
 - 5. Provision for inspection/testing at the stored location.
 - 6. Provision for security until completion of installation.

1.3 SCHEDULE OF VALUES

- A. Type schedule on AIA Document G703. Owner's Standard Invoice/Schedule of Values or Contractor's standard forms and automated printout equivalent to the AIA Document will be considered for approval by Owner upon Contractor's request. Identify schedule with:
1. Title of Project and location.
 2. Architect and Project number.
 3. Name and Address of Contractor.
 4. Contract designation.
 5. Date of submission.
- B. Schedule shall list the installed dollar value of the component parts of the Work in sufficient detail to serve as a basis for computing values for progress payments during construction.
- C. List each subcontract first using the Table of Contents of the Project Manual as the format.
1. Next list any allowances included in the contract amount.
 2. List each major section or portion of work to be performed by the Contractor.
 3. List Contractor's fee separately.
 4. List any contingencies.
 5. Identify each line item with the number and title of the respective major section of the specifications.
 6. Subdivide items to correspond with cost correlation requirements for construction progress schedule.
- D. For each major line item list sub-values of major products by building area or floor level or other operations under the item.
- E. For the various portions of the Work:
1. Each item shall include a directly proportional amount of the Contractor's overhead and profit.
 2. For items on which progress payments will be requested for stored materials, break down the value into:
 - a. The cost of the materials, delivered and unloaded, with taxes paid.
 - b. The total installed value.

- B. The sum of all values listed in the schedule shall equal the total Contract Sum.
- C. Refer to General Conditions, Article 12, for changes.

1.4 APPLICATIONS FOR PAYMENT

A. Format and Data Required:

- 1. Submit applications typed on AIA Document G702/703, Application for Payment. Contractor's standard forms and automated print-out equivalent to the AIA Document will be considered for approval by Architect upon request by the Contractor.
- 2. Submit 2 copies with "wet" signatures.
- 3. Add provision for Inspector of Record's signature.

B. Provide itemized data on continuation sheet:

- 1. Format, schedules, line items and values: Those of the Schedule of Values accepted by Architect.
- 2. Include Payment Application number.

C. Preparation of Application for Each Progress Payment:

1. Application Form:

- a. Fill in required information, including that for Change Orders executed prior to date of submittal of application along with the number assigned to each Change Order.
- b. Fill in summary of dollar values to agree with respective totals indicated on continuation sheets.
- c. Certification that the Project Record Documents are current with the progress status of the Project.
- d. Execute certification with signature of a responsible officer of Contract firm.

2. Continuation Sheets:

- a. Fill in total list of all scheduled component items of Work, with item number and scheduled dollar value for each item.
- b. Fill in dollar value in each column for each scheduled line item when work has been performed or products stored.
 - 1) Round off values to nearest dollar, or as specified for Schedule of Values, and percent of item completion.
- c. List each Change Order executed prior to date of submission, at the end of the continuation sheets.

- 1) List by Change Order number, and description, as for an original component item of work.

D. Substantiating Data for Progress Payments:

1. When Owner or Architect requires substantiating data, submit information, with a cover letter identifying:
 - a. Project.
 - b. Application number and date.
 - c. Detailed list of enclosures.
 - d. For stored products.
 - 1) Item number and identification as shown on application.
 - 2) Description of specific Material.
2. Submit 1 copy of data and cover letter for each copy of application.
3. Revised updated CPM schedule.
4. Current period's General Contractor Conditional Waiver and the prior period's Unconditional Waiver.
5. Waivers from Subcontractors.
6. Copies of invoices for National Purchase Agreement (NPA) items.
7. Corrections and updates to "as-built" documents.

E. Preparation of Application for Final Payment:

1. Fill in application form as specified for progress payments.
2. Use continuation sheet for presenting the final statement of accounting as specified in Section 01700 - CONTRACT CLOSEOUT.

F. Submittal Procedure:

1. Submit Applications for Payment to Owner at the times stipulated in the Agreement.
2. Number: 3 copies of each Application.
3. When Owner, Inspector of Record, and Contractor agree on percentages to be requested, and when agreed and signed by them and Architect, Architect will transmit the Certificate for Payment to Owner.
4. Approval and signing of the Application for Payment by Owner and Architect is contingent upon approval of the current status of the As-

Built Drawings/Record Documents and submittal of updated CPM schedule.

1.5 CHANGE ORDERS

- A. Change Orders shall be processed by the Architect in accordance with the Conditions of the Contract, Supplementary Conditions of the Contract, and as herein specified.
- B. Coordination with Contractor's Submittals:
 - 1. Revise Schedule of Values and Application for Payment forms monthly to record each change as a separate item of Work, and to record the adjusted Contract Sum.
 - 2. Upon completion of work under a Change Order, enter pertinent changes in record documents.

PART 2 – PRODUCTS (Not Used)

PART 3 – EXECUTION (Not Used)

END OF SECTION

SECTION 01 31 00 – PROJECT MANAGEMENT AND COORDINATION

PART 1 - GENERAL

1.1 SUMMARY

- A. This Section describes the requirements for Project coordination.

1.2 DESCRIPTION OF REQUIREMENTS

- A. Minimum administrative and supervisory requirements necessary for coordination of Work shall be fulfilled collectively by the Contractor in coordination with subcontractors including, but not necessarily limited to, the following:
1. Coordination drawings.
 2. Coordination meetings.
 3. Administrative coordinating personnel.
 4. Contractor's coordination of work.

1.3 COORDINATION MEETINGS

- A. Schedule and conduct meetings and conferences at project site, unless otherwise indicated.

1.4 ADMINISTRATIVE COORDINATION PERSONNEL

- A. Provide a General Superintendent and other administrative and supervisory personnel required for performance of the Work.
- B. Provide specific coordinating personnel for each subcontractor as reasonably required for interfacing Work with other work of total Project.
- C. Submittal of Staff Names, Duties: Within 7 days of Notice to Proceed submit to the Owner a listing of principal staff assignments and consultants, including names, addresses and telephone numbers.

1.5 CONTRACTOR'S COORDINATION OF WORK

- A. Provide and coordinate the following:
1. General and special services and operations to furnish and install Work.
 2. Primary, major and accessory materials, and items necessary to complete the installation.
 3. Labor operations and material items reasonably incidental for finishing.
 4. Performance of work and delivery of materials in accordance with

established construction schedules.

- B. Coordinate all aspects of construction operations, generally, and specifically as required to provide Owner with a complete, operable facility.
1. Resolve any dispute over coordination, or failure to coordinate, such that resolution is consistent with Contract Documents. When such resolution is not possible, refer to the General Conditions.
 2. Where proper execution of this Work depends on the work of any other contractor, inspect and promptly report to Architect any defects in such work that render it unsuitable for such proper execution and results.
 3. Cooperate with other contractors on the Project site and with Architect so that completion of all work can proceed with prudent speed.
 - a. Furnish other contractors, whose work is fitted to this work, detail and erection drawings giving full information regarding the fabrication and assembly of this Work.
 - b. So far as possible, drawings shall indicate checked field measurements.
 - c. Cooperate in timing this Work to join with the work of other contractors or the Owner.
 4. Check the drawings of other contracts for interferences with this Work and promptly report to Architect, in writing, any such interferences.
 5. Submit complete information, including Drawings, descriptions, sketches, marked prints, etc., as required for Architect's review and coordination of drawings by others which are a part of this Work.
- C. Mechanical, Electrical, and Related Systems Coordination: Prior to proceeding with the work, and before installation, coordinate and work out all "tight" conditions involving work of various Sections.
1. Before work proceeds in these areas, prepare supplemental drawings for review by the Architect.
 2. Provide all work necessary to coordinate tight conditions, including supplemental drawings in sufficient detail for showing that all work is coordinated in "tight" areas, and additional labor and materials necessary to overcome "tight" conditions at no increase in cost to the Owner.
 3. Coordination of "tight" conditions shall include:
 - a. Providing sufficient clear space around all equipment necessary for maintenance access and as required by Code.
 - b. Adjustments in depth, position, and elevation of underground and overhead utilities at points of conflict. Utility space conflicts

shall be resolved by giving precedence to those utilities which are called out to be sloped. The term "utility" as used in this paragraph includes: all piping, conduit, and ductwork.

1.6 COORDINATION DRAWINGS

- A. Submit plans and cross-sections in sufficient detail to show coordinated layout of all ducts, pipes, electrical work, access doors, above ceiling clearances, canopy rigging, acoustical curtains, and other related items. Plans and cross-sections shall be provided that include all underground ducts, electrical ductbanks, piping, and other underground utilities.
- B. Engage professional drafter to prepare these drawings to one-quarter scale on Auto-CAD with title blocks to match the Contract Drawings.
 - 1. These plans shall reflect existing dimensions as field-verified by the Contractor.
 - 2. Plans shall be uniform and identical and shall serve as backgrounds for preparation of shop or layout drawings required under Divisions 15 and 16 and ultimately for recording of as-built information required under these divisions.
 - 3. Where additional sheets of elevations, sections, details, and/or diagrams are required, such sheets shall match the Contract Drawings with respect to size and title block.
 - 4. Prior to beginning excavation for structural footings and utilities, submit a coordination plan showing all underground utilities including: all underground piping, underground ductwork, electrical and communication ductbanks.
 - a. The plan shall be a composite overlay of sheets each dedicated to a single underground utility using a common background and scale.
 - b. Dimensions shall be sufficient to clearly indicate the position and depth of each utility relative to structural footings, above grade structures, and finished grade.
 - c. At points where the plan indicates that utilities will cross each other, cross a structural footing, or run within six (6) feet parallel to either each other or a structural footing, provide a cross section drawing.
 - d. Cross section drawings shall clearly show the relative positions and depths of each utility and structural footing.
 - e. The composite plan and cross section drawing(s) shall be updated to "as-builts" and submitted with the Project Record (As-Built) Drawings.
- C. Do not commence work until the Architect has reviewed these Drawings.

1.7 MISCELLANEOUS PROVISIONS

- A. Prior to starting a particular type or kind of work:
1. Examine for relevant information, all Contract Documents and subsequent data issued;
 2. Check accepted submittals and verify dimensions at job site;
 3. Consult manufacturers for instructions applicable to conditions under which Work is to be installed;
 4. Inspect areas, surfaces or construction receiving the Work.
 - a. Start of work shall signify compliance with the above requirements and acceptance of previously placed construction or substrates as being in satisfactory condition to achieve proper installations and first quality workmanship as intended under these specifications.
 - b. Failure to so inspect and report shall constitute an acceptance of the other contractor's work.

PART 2 – PRODUCTS (Not Used)

PART 3 – EXECUTION (Not Used)

END OF SECTION

SECTION 01 31 10 – FIELD ENGINEERING

PART 1 - GENERAL

1.1 FIELD MEASUREMENTS AND EXISTING CONDITIONS

- A. Contractor Responsibility: Exact field measurements are responsibility of the Contractor. Any required off-sets, additional fittings, re-routing of existing or new work to provide serviceable system within the location shown, and to maintain head room and clearances to match existing construction, are responsibility of the Contractor.
- B. Layout of the Work: The Contractor shall employ, at the Contractor's own expense, Registered Civil Engineer or Licensed Land Surveyor. Contractor's engineer or surveyor will provide layout of the work of the Project and establish all reference points and elevations required for construction.

1.2 GRADES, LINES AND LEVELS

- A. Identification: Owner will identify existing benchmarks, control points, and property corners.
- B. Reference Points: Locate existing permanent benchmarks, control points, and similar reference points before beginning the Work. Preserve and protect permanent benchmarks and control points during construction operations.
- C. Benchmarks: Establish and maintain a minimum of six permanent benchmarks on Project site, referenced to data established by survey control points. Comply with authorities having jurisdiction for type and size of benchmark.
 - 1. Record benchmark locations, with horizontal and vertical data, on Project Record Documents.
 - 2. Where the actual location or elevation of layout points cannot be marked, provide temporary reference points sufficient to locate the Work.
 - 3. Remove temporary reference points when no longer needed. Restore marked construction to its original condition.
- D. Preservation: All stakes, boundary lines, bench marks or survey marks, etc., which have been or may be established in any part of the Project site or adjacent thereto shall be carefully preserved and respected by the Contractor and shall be restored at the Contractor's expense if lost or destroyed as result of the Contractor's operations.
 - 1. Replace lost or destroyed permanent benchmarks and control points promptly. Base replacements on the original survey control points.

- E. Conflict: The Contractor will be held responsible for correctness of layout, for establishing location of existing concealed utility lines, and for notifying the Architect in writing in event of conflict with the Drawings. In such case, the Contractor shall not proceed until instructed by the Architect.
- F. Certified Survey: On completion of foundation walls, major site improvements, and other work requiring field-engineering services, prepare a certified survey showing dimensions, locations, angles, plumbness and elevations of construction and sitework.
- G. Final Property Survey: Prepare a final property survey showing significant features (real property) for Project. Include on the survey a certification, signed by land surveyor that principal metes, bounds, lines, and levels of Project are accurately positioned as shown on the survey.
 - 1. Show boundary lines, monuments, streets, site improvements and utilities, existing improvements and significant vegetation, adjoining properties, acreage, grade contours, and the distance and bearing from a site corner to a legal point.

END OF SECTION

SECTION 01 33 00 - SUBMITTAL PROCEDURES

PART 1 - GENERAL

1.1 RELATED DOCUMENTS

- A. Drawings and general provisions of the Contract, including General and Supplementary Conditions and other Division 1 Specification Sections, apply to this Section.

1.2 SUMMARY

- A. This Section includes administrative and procedural requirements for submitting Shop Drawings, Product Data, Samples, and other submittals.

1.3 SUBMITTAL PROCEDURES

- A. General: Electronic copies of CAD Drawings of the Contract Drawings will not be provided by Architect for Contractor's use in preparing submittals.
- B. Coordination: Coordinate preparation and processing of submittals with performance of construction activities.
- C. Submittals Schedule: Comply with requirements in Division 1 Section "Construction Progress Documentation" for list of submittals and time requirements for scheduled performance of related construction activities. Submittals should be submitted by contractor to architect **within 30 days from notice to proceed**.
- D. Processing Time: Allow enough time for submittal review, including time for resubmittals, as follows. Time for review shall commence on Architect's receipt of submittal. No extension of the Contract Time will be authorized because of failure to transmit submittals enough in advance of the Work to permit processing, including resubmittals.
 - 1. Initial Review: Allow 10 days for initial review of each submittal. Allow additional time if coordination with subsequent submittals is required. Architect will advise Contractor when a submittal being processed must be delayed for coordination.
 - 2. Resubmittal Review: Allow 10 days for review of each resubmittal.
- E. Identification: Place a permanent label or title block on each submittal for identification.
 - 1. Indicate name of firm or entity that prepared each submittal on label or title block.
 - 2. Include the following information on label for processing and recording action taken:
 - a. Project name.

- b. Date.
 - c. Name and address of Architect.
 - d. Name and address of Contractor.
 - e. Name and address of subcontractor.
 - f. Name and address of supplier.
 - g. Name of manufacturer.
 - h. Submittal number or other unique identifier, including revision identifier.
 - i. Number and title of appropriate Specification Section.
 - j. Drawing number and detail references, as appropriate.
 - k. Location(s) where product is to be installed, as appropriate.
- F. Transmittal: Package each submittal individually and appropriately for transmittal and handling. Transmit each submittal using a transmittal form.
- G. Distribution: Furnish copies of final submittals to manufacturers, subcontractors, suppliers, fabricators, installers, authorities having jurisdiction, and others as necessary for performance of construction activities.
1. Use for Construction: Use only final submittals with mark indicating "Approval notation from Architect's action stamp".

PART 2 - PRODUCTS

2.1 ACTION SUBMITTALS

- A. General: Prepare and submit Action Submittals required by individual Specification Sections.
- B. Product Data: Collect information into a single submittal for each element of construction and type of product or equipment.
1. Mark each copy of each submittal to show which products and options are applicable.
 2. Include the following information, as applicable:
 - a. Manufacturer's written recommendations.
 - b. Manufacturer's product specifications.
 - c. Manufacturer's installation instructions.
 - d. Standard color charts.
 - e. Manufacturer's catalog cuts.
 - f. Standard product operation and maintenance manuals.
 - g. Compliance with specified referenced standards.
 3. Submit Product Data concurrent with Samples.
 4. Number of Copies: Submit four copies of Product Data, unless otherwise indicated.
- C. Shop Drawings: Prepare Project-specific information, drawn accurately to scale. Do not base Shop Drawings on reproductions of the Contract Documents or standard printed data.

1. Preparation: Fully illustrate requirements in the Contract Documents. Include the following information, as applicable:
 - a. Dimensions.
 - b. Identification of products.
 - c. Fabrication and installation drawings.
 - d. Roughing-in and setting diagrams.
 - e. Wiring diagrams showing field-installed wiring, including power, signal, and control wiring.
 - f. Shopwork manufacturing instructions.
 - g. Schedules.
 - h. Design calculations.
 - i. Compliance with specified standards.
 - j. Relationship to adjoining construction clearly indicated.
 2. Sheet Size: Except for templates, patterns, and similar full-size drawings, submit Shop Drawings on sheets at least 8-1/2 by 11 inches (215 by 280 mm) but no larger than 30 by 40 inches (750 by 1000 mm).
 3. Number of Copies: Submit four opaque copies of each submittal, Architect will retain two copies; remainder will be returned.
- D. Samples: Submit Samples for review of kind, color, pattern, and texture for a check of these characteristics with other elements and for a comparison of these characteristics between submittal and actual component as delivered and installed.
1. Samples for Initial Selection: Submit manufacturer's color charts consisting of units or sections of units showing the full range of colors, textures, and patterns available.
 - a. Number of Samples: Submit one full set of available choices where color, pattern, texture, or similar characteristics are required to be selected from manufacturer's product line. Architect will return submittal with options selected.

PART 3 - EXECUTION

3.1 CONTRACTOR'S REVIEW

- A. Review each submittal and check for coordination with other Work of the Contract and for compliance with the Contract Documents. Note corrections and field dimensions. Mark with approval stamp before submitting to Architect.

3.2 ARCHITECT'S ACTION

- A. General: Architect will not review submittals that do not bear Contractor's approval.
- B. Action Submittals: Architect will review each submittal, make marks to indicate corrections or modifications required, and return it. Architect will stamp each submittal

with an action stamp and will mark stamp appropriately to indicate action taken, as follows:

END OF SECTION

SECTION 01 40 00 – QUALITY REQUIREMENTS

PART 1 - GENERAL

1.1 SUMMARY

- A. This Section describes the requirements for Owner furnished testing and inspection services which include the following:
 - 1. Observation by Inspector of Record.
 - 2. Laboratory responsibilities.
 - 3. Laboratory reports.
 - 4. Limits on testing laboratory authority.
 - 5. Contractor responsibilities.
 - 6. Schedule of inspections and tests.
- B. These services are identified to indicate the requirement for cooperation and assistance needed by Owner's testing and inspection agency.

1.2 QUALITY ASSURANCE

- A. Testing and Inspection Agency Qualifications: A testing and inspection agency must have a minimum 5 years continuing experience preceding date of these Contract Documents, and be qualified in accordance with the following American Society for Testing and Materials (ASTM) publications:
 - 1. ASTM E 548-84 Standard Practice for Generic Criteria for use in the Evaluation of Testing and Inspection Agencies.
 - 2. ASTM E 699-79 (1984) Standard Criteria for Evaluation of Agencies Involved in Testing, Quality Assurance, and Evaluating Building Components in Accordance with Test Methods Promulgated by ASTM Committee E-6.
- B. Testing Equipment: Calibrated at intervals with devices of accuracy traceable to either National Bureau of Standards or accepted values of natural physical constants.

1.3 INSPECTION AND TESTING PERSONNEL AND FACILITIES

- A. Inspector of Record:
 - 1. The Owner will employ one or more qualified Inspectors of Record, acceptable to the Local Building Department issuing Permits who will be employed continuously at the construction site, working under the Owner Representative's general direction. The IOR(s) will observe

- progress of the work and to report to the Owner any non-conformance with Contract Documents.
2. In compliance with the State Building Code, Part 1, Title 24 of the California Code of Regulations, Article 7-145, the Inspector of Record shall have personal knowledge, obtained by continuous inspection of all parts of the work of construction in all stages of its progress, to ensure that the work is in accordance with the approved contract documents.
 3. Specific duties and limits of responsibilities include the following:
 - a. Observing and spot checking materials upon arrival at site, and work in progress, to determine conformance with Contract Documents. Reporting any defects immediately to the Owner.
 - b. Maintaining liaison with the Contractor and his Subcontractors only through Contractor's superintendent.
 - c. Evaluating Contractor's suggestions and reporting them with recommendations to the Owner for final decision.
 - d. Remaining alert to the Construction Schedule and immediately reporting any potential delays and problems to the Owner.
 - e. Maintaining a Daily Log of activities on site, pertinent to a continuous project report record.
 - f. Preparing a Verified Report every 3 months (or sooner if required for a specific project schedule).
 - g. Receiving Samples of construction materials at the jobsite.
 - h. Scheduling and accompanying regulatory inspectors through the project and reporting to the Owner the results of such inspection visits.
 - i. Being alert to conditions which could affect Hospital's existing operation.
 - j. Reviewing and verifying degree of work completion with that cited in Contractor's monthly payment request.
 - k. Maintaining Contract information and Shop Drawing files.
 - l. Preparing a Field Inspection Report of incomplete or unsatisfactory work at intervals throughout the work progress. Checking off such items when made complete and satisfactory by Contractor.
 - m. Attending project meetings in accordance with specifications Section 013100.

- n. Enforcing Infection Control requirements.
 - o. Provide all coordination for independent Testing Laboratories.
 - p. Participate in formation of Final Punch List.
- B. Local Permit Issuing Agency will approve the Inspector of Record for the project who shall be allowed access to the project site at any time.
- C. Geotechnical Engineer: Observation of all excavations and engineering control of all fills and backfills shall be by a Geotechnical Engineer.
- 1. Owner will contract with the Geotechnical Engineer for observation and testing of all excavations and engineering control of all fills and backfills.
 - 2. The Geotechnical Engineer shall submit a Final Report verifying that Work has been performed in accordance with the requirements of the Contract Documents and Soils Investigation Report(s) prepared for this Project.
 - 3. The Geotechnical Engineer shall distribute the Final Report in accordance with Paragraph 1.4, B.
- D. Testing and Inspection Agency:
- 1. The Owner will employ and pay for the services of an independent testing and inspection agency to perform the tests and inspections required herein except where noted otherwise.
 - a. Employment of the testing and inspection agency shall in no way relieve the Contractor's obligation to perform the work defined in the Contract Documents.
 - 2. Limitations of authority of the Testing and Inspection Agency:
 - a. Testing Agency is not authorized to:
 - 1) Release, revoke, alter, or enlarge on the requirements of the Contract Documents;
 - 2) Approve or accept any portion of the Work, or;
 - 3) Perform any duties of the Contractor.
 - 3. All work shall conform to the requirements of state and local applicable Codes.
 - 4. Testing and inspection agency shall perform tests and inspections as required by applicable regulation as indicated in the specification Sections, and as directed by the Owner and required by the Code.
 - 5. Testing and inspection agency shall prepare, cure, store, and transport

job samples to the Laboratory.

6. At the completion of the Project, verified reports shall be submitted as required by CCR, Title 22 and as directed.

1.4 LABORATORY REPORTS

- A. After each inspection and test, promptly submit copies of laboratory report which includes:

1. Date issued,
2. Project title and number,
3. Name of Inspector from inspection agency,
4. Date and time of sampling or inspection,
5. Identification of product and specifications section,
6. Location in the Project,
7. Type of inspection or test,
8. Date of test,
9. Results of tests,
10. Conformance with Contract Documents,
11. Whether original test or re-test,
12. State/local permit number,

- B. Reports shall be distributed to the following:

1. Architect of Record
2. Inspector of Record (I.O.R.)
3. General Contractor
4. Owner.
5. Applicable Consultant
6. Local Jurisdiction where applicable

1.5 LABORATORY RESPONSIBILITIES

- A. Provide qualified personnel at site. Cooperate with Architect/Inspector of Record and Contractor in performance of services.

- B. Perform specified inspecting, sampling, and testing of Products in accordance with specified standards.
- C. Ascertain compliance of materials and mixes with requirements of Contract Documents.
- D. Promptly notify Architect, IOR and Contractor of observed irregularities or non-conformance of Work or Products.
- E. Perform additional inspection and test required by Architect.
- F. Attend preconstruction meetings and progress meetings when requested.

1.6 CONTRACTOR'S RESPONSIBILITIES

- A. Cooperate with Inspector of Record and Testing and Inspection Agency and provide access to Work, including off-site manufacturer's or fabricator's operations.
 - 1. Provide required quantities of material samples to be tested.
 - 2. Samples will be selected and taken by representative of Testing and Inspection Agency.
- B. Furnish copies of product data and test reports as required.
- C. Furnish incidental labor and facilities:
 - 1. To provide access to work to be tested;
 - 2. To obtain and handle samples at the Project site, or at the source of the Product to be tested or inspected;
 - 3. To facilitate inspections and tests, and;
 - 4. For storage and curing of test samples at the Project site.
- D. Provide, on a weekly basis, a Short Interval Project Schedule with a minimum three-week duration which identifies upcoming testing requirements.
- E. Schedule the tests and inspections required by the Contract Documents and applicable codes and regulations with the Inspector of Record and the Testing and Inspection Agency, a minimum of 48 hours in advance.
 - 1. When tests or inspections cannot be performed after such notice, or if re-tests and re-inspections are required due to the fault of the Contractor, all costs for such re-work shall be deducted from the Contract Amount. If the remaining unpaid balance in the Contract is insufficient to cover the Change Order for this work, Contractor shall pay the difference directly to the Owner.
 - 2. Do not cover corrected Work until said Work has been re-tested and or

re-inspected satisfactorily.

- F. Arrange with Owner's Testing and Inspection Agency and pay for additional samples and tests required for the Contractor's convenience when approved by Owner.
- G. Contractor shall pay costs for the following specified items:
 - 1. Design mixes for:
 - a. Cast-in-Place concrete
 - b. Asphalt paving
 - 2. Redesign of mixes due to change in source of ingredients.
 - 3. Certified mill test reports.
 - 4. Pre-construction tests for masonry units.
 - 5. Preparation and delivery to laboratory of pre-construction masonry prisms for testing.
- H. Notification of Architect:
 - 1. In addition to tests and inspections called for in this Section, notify applicable parties of inspections and testing called for in the individual Sections of the Specifications or on the Drawings.
 - 2. Notify 48 hours in advance, to assure inspections prior to covering up or closing in of work involved. Any work covered up before such required inspection or testing shall be uncovered or removed at the Contractor's expense.

PART 2 – PRODUCTS (Not Used)

PART 3 – EXECUTION (Not Used)

END OF SECTION

SECTION 01 43 73

SCHEDULE OF VALUES

NAME OF BIDDER: _____

DATE: _____

DIV	TITLE	AMOUNT	\$/SQ. FT	COMMENTS
01	General Conditions	\$ _____	\$ _____	
02	Demolition	\$ _____	\$ _____	
02	Saw cut slab	\$ _____	\$ _____	
03	Concrete	\$ _____	\$ _____	
04	Masonry	\$ _____	\$ _____	
05	Steel	\$ _____	\$ _____	
06	Woods and Plastics	\$ _____	\$ _____	
07	Thermal and Moisture Protection	\$ _____	\$ _____	
08	Openings	\$ _____	\$ _____	
09	Finishes	\$ _____	\$ _____	
10	Specialties	\$ _____	\$ _____	
12	Furnishings	\$ _____	\$ _____	
21	Fire Suppression	\$ _____	\$ _____	
22	Plumbing	\$ _____	\$ _____	
23	HVAC	\$ _____	\$ _____	
26	Electrical	\$ _____	\$ _____	
31	Earthwork	\$ _____	\$ _____	
32	Landscape	\$ _____	\$ _____	
33	Utilities	\$ _____	\$ _____	
	SUBTOTAL	\$ _____	\$ _____	
	OVERHEAD AND PROFIT	\$ _____	\$ _____	
	TOTAL COST	\$ _____	\$ _____	

END OF SECTION

SECTION 01 50 00 - TEMPORARY FACILITIES AND CONTROLS

PART 1 - GENERAL

1.1 RELATED DOCUMENTS

- A. Drawings and general provisions of the Contract, including General and Supplementary Conditions and other Division 1 Specification Sections, apply to this Section.

1.2 SUMMARY

- A. This Section includes requirements for temporary utilities, support facilities, and security and protection facilities.

1.3 USE CHARGES

- A. General: Cost or use charges for temporary facilities shall be included in the Contract Sum. Allow other entities to use temporary services and facilities without cost.
- B. Water Service: Pay water service use charges for water used by all entities for construction operations.
- C. Electric Power Service: Pay electric power service use charges for electricity used by all entities for construction operations.

1.4 QUALITY ASSURANCE

- A. Electric Service: Comply with NECA, NEMA, and UL standards and regulations for temporary electric service. Install service to comply with NFPA 70.

PART 2 - PRODUCTS

2.1 MATERIALS

2.2 TEMPORARY FACILITIES

- A. Field Offices, General: Prefabricated or mobile units with serviceable finishes, temperature controls, and foundations adequate for normal loading.
- B. Common-Use Field Office: Of sufficient size to accommodate needs of construction personnel. Keep office clean and orderly. Furnish and equip offices as follows:
 - 1. Furniture required for Project-site documents including file cabinets, plan tables, plan racks, and bookcases.

2. Heating and cooling equipment necessary to maintain a uniform indoor temperature of 68 to 72 deg F.
3. Lighting fixtures capable of maintaining average illumination of 20 fc at desk height.

2.3 EQUIPMENT

- A. Fire Extinguishers: Portable, UL rated; with class and extinguishing agent as required by locations and classes of fire exposures.
- B. Heating Equipment: Unless Owner authorizes use of permanent heating system, provide vented, self-contained, liquid-propane-gas or fuel-oil heaters with individual space thermostatic control.

PART 3 - EXECUTION

3.1 INSTALLATION, GENERAL

- A. Locate facilities where they will serve Project adequately and result in minimum interference with performance of the Work. Relocate and modify facilities as required by progress of the Work.
- B. Provide each facility ready for use when needed to avoid delay. Do not remove until facilities are no longer needed or are replaced by authorized use of completed permanent facilities.

3.2 TEMPORARY UTILITY INSTALLATION

- A. General: Install temporary service or connect to existing service.
 1. Arrange with utility company, Owner, and existing users for time when service can be interrupted, if necessary, to make connections for temporary services.
- B. Water Service: Install water service and distribution piping in sizes and pressures adequate for construction.
- C. Sanitary Facilities: Provide temporary toilets, wash facilities, and drinking water for use of construction personnel. Comply with authorities having jurisdiction for type, number, location, operation, and maintenance of fixtures and facilities.
- D. Heating: Provide temporary heating required by construction activities for curing or drying of completed installations or for protecting installed construction from adverse effects of low temperatures or high humidity. Select equipment that will not have a harmful effect on completed installations or elements being installed.
- E. Electric Power Service: Provide electric power service and distribution system of sufficient size, capacity, and power characteristics required for construction operations.
- F. Lighting: Provide temporary lighting with local switching that provides adequate illumination for construction operations, observations, inspections, and traffic conditions.

- G. Telephone Service: Provide temporary telephone service in common-use facilities for use by all construction personnel. Install one telephone line(s) for each field office.
- H. Traffic Controls: Comply with requirements of authorities having jurisdiction.
 - 1. Protect existing site improvements to remain including curbs, pavement, and utilities.
 - 2. Maintain access for fire-fighting equipment and access to fire hydrants.
- I. Parking: Provide temporary parking areas for construction personnel.
- J. Dewatering Facilities and Drains: Comply with requirements of authorities having jurisdiction. Maintain Project site, excavations, and construction free of water.
 - 1. Dispose of rainwater in a lawful manner that will not result in flooding Project or adjoining properties nor endanger permanent Work or temporary facilities.
 - 2. Remove snow and ice as required to minimize accumulations.
- K. Project Identification and Temporary Signs: Provide Project identification sign. Install signs where indicated to inform public and individuals seeking entrance to Project. Unauthorized signs are not permitted.
- L. Waste Disposal Facilities: Provide waste-collection containers in sizes adequate to handle waste from construction operations. Comply with requirements of authorities having jurisdiction. Comply with Division 1 Section "Cleaning" for progress cleaning requirements.
- M. Temporary Stairs: Until permanent stairs are available, provide temporary stairs where ladders are not adequate.

3.3 SECURITY AND PROTECTION FACILITIES INSTALLATION

- A. Environmental Protection: Provide protection, operate temporary facilities, and conduct construction in ways and by methods that comply with environmental regulations and that minimize possible air, waterway, and subsoil contamination or pollution or other undesirable effects.
- B. Temporary Erosion and Sedimentation Control: Provide measures to prevent soil erosion and discharge of soil-bearing water runoff and airborne dust to adjacent properties and walkways, according to requirements of authorities having jurisdiction.
 - 1. Inspect, repair, and maintain erosion- and sedimentation-control measures during construction until permanent vegetation has been established.
- C. Stormwater Control: Comply with authorities having jurisdiction. Provide barriers in and around excavations and subgrade construction to prevent flooding by runoff of stormwater from heavy rains.
- D. Site Enclosure Fence: Before construction operations, furnish and install site enclosure fence in a manner that will prevent people and animals from easily entering site except by entrance gates.

- E. Barricades, Warning Signs, and Lights: Comply with requirements of authorities having jurisdiction for erecting structurally adequate barricades, including warning signs and lighting.
- F. Temporary Fire Protection: Install and maintain temporary fire-protection facilities of types needed to protect against reasonably predictable and controllable fire losses. Comply with NFPA 241.
 - 1. Supervise welding operations, combustion-type temporary heating units, and similar sources of fire ignition according to requirements of authorities having jurisdiction.
 - 2. Develop and supervise an overall fire-prevention and -protection program for personnel at Project site. Review needs with local fire department and establish procedures to be followed. Instruct personnel in methods and procedures. Post warnings and information.

3.4 OPERATION, TERMINATION, AND REMOVAL

- A. Maintenance: Maintain facilities in good operating condition until removal.
 - 1. Maintain operation of temporary enclosures, heating, cooling, humidity control, ventilation, and similar facilities on a 24-hour basis where required to achieve indicated results and to avoid possibility of damage.
- B. Termination and Removal: Remove each temporary facility when need for its service has ended, when it has been replaced by authorized use of a permanent facility, or no later than Substantial Completion. Complete or, if necessary, restore permanent construction that may have been delayed because of interference with temporary facility. Repair damaged Work, clean exposed surfaces, and replace construction that cannot be satisfactorily repaired.

END OF SECTION

SECTION 01 60 00- PRODUCT REQUIREMENTS

PART 1 - GENERAL

1.1 SUMMARY

- A. Work Included: This Section contains definitions, product requirements and requirements for prior approved items.
- B. Delivery and storage of materials and equipment.
- C. Procedures for selecting products and approving substitutions.

1.2 DEFINITIONS

- A. General: Definitions are not intended to negate the meaning of other terms used in Contract Documents, including specialties, systems, structure, finishes, accessories, furnishings, special construction, and similar terms, which are self-explanatory and have recognized meanings in the construction industry.
- B. Products: Purchased items for incorporation into the Work, regardless of whether specifically purchased for Project or taken from Contractor's stock of previously purchased products.
- C. Materials: Products which must be substantially cut, shaped, worked, mixed, finished, refined, or otherwise fabricated, processed, installed, or applied to form units of Work.
- D. Appliances, Equipment, and Fixtures: Products with operational parts, regardless of whether motorized or manually operated and particularly including products with service connections (wiring, piping, etc.).
- E. System: A unit of Work (i.e., structural system, vacuum system, etc.) shown or specified to include particular products, materials, appliances, equipment, or fixtures.
- F. Substitutions: Where products, materials, appliances, equipment, or fixtures are listed by trade name(s), manufacturer name(s), or catalog reference(s) or where these items are shown or specified as part of a system or systems, items or systems proposed for use by Contractor that are not listed or differ from those shown or specified as part of a system will be considered substitutions.
 - 1. Submit substitutions in accordance with requirements of this Section.
 - 2. The requirements for substitutions do not apply to specified Contractor options. Revisions to Contract Documents, where requested by Owner or Architect are changes, not substitutions.
 - 3. Contractor's determinations of and compliance with governing regulations and orders issued by governing authorities do not constitute

substitutions, and do not constitute a basis for change orders; except as provided for under substitution procedures in this Section or elsewhere in Contract Documents.

- G. Prior -to-Bid Approvals: Products, materials, appliances, equipment, fixtures, or systems that have been proposed as substitutions and accepted by Owner prior to bid.

1.3 DESCRIPTION

- A. General: Specific products, materials, appliances, equipment, fixtures, accessories, manufacturers, and proprietary mentioned by name, grade, or brand, in Specifications or on Drawings have been selected for their particular fitness, availability, and desirability for use appropriate to Work of this Project and are intended to establish the standard of quality.
- B. Compliance: The compliance requirements, for individual products are multiple in nature and may include generic, descriptive, proprietary, performance, prescriptive, compliance with standards, compliance with codes, conformance with graphic details, and other similar forms and methods of indicating requirements.

1.4 PRODUCT REQUIREMENTS

- A. General: Provide products which comply with requirements, and which are undamaged and unused at time of installation, and which are complete with accessories, trim, finish, safety guards, and other devices and details needed for a complete installation and for intended use.
 - 1. Materials shall be new unless otherwise specified and unused, except for testing of current production models on date of order, undamaged, and un-deteriorated at time of use.
 - 2. Identify materials in accordance with accepted trade standards and requirements of this Section.
 - 3. Select and use methods or processes, including intermediate processes, which will produce the specified finished material or product.
 - 4. Ascertain that the Work, including materials, products, and equipment delivered and installed, is in full compliance with the Contract Documents and appropriate submittals.
 - 5. Standard Products: Where available, provide standard products of types which have been produced and used previously and successfully on other projects and in similar applications.
 - 6. Continued Availability: Where additional amounts of product, by nature of its application, are likely to be needed by Owner at a later date for maintenance and repair or replacement work, provide a standard, domestically produced product which is likely to be available to Owner at

such later date.

- B. Nameplates: Except as otherwise indicated for required approval labels and operating data, do not permanently attach or imprint manufacturer's or producer's nameplates or trademarks on exposed surfaces of products which will be exposed to view either in occupied spaces or on exterior of the Work.
 - 1. Labels: Locate required labels and stamps on a concealed surface or, where required for observation after installation, on an accessible surface which, in occupied spaces, is not conspicuous.
 - 2. Equipment Nameplates: Provide permanent nameplate on each item of service-connected or power-operated equipment. See sections specifying equipment requirements for specifics.

1.5 QUALITY ASSURANCE

- A. Special Requirement: Due to certain Owner requirements, Owner will not consider substitutions on certain items. Therefore, substitutions will not be considered for items followed by the words: "no substitution(s)."
- B. Architect's Compensation:
 - 1. Except as limited by provisions of Owner-Architect or Owner-Contractor Agreements, Contractor shall reimburse Owner for compensation paid to Architect for evaluation of substitution proposals made during construction, whether or not substitution is accepted by Owner.
 - 2. Refer to Request for Substitution form at the end of this Section.
- C. Delays and Costs:
 - 1. Substitution proposals made during construction shall be in accordance with procedures outlined in this Section, and be made in sufficient time to allow for adequate time for Architect's review and evaluation.
 - 2. Delays and added costs associated with inadequate supportive data, necessary extended evaluations, or redesign work caused by substitutions shall be borne by Contractor.
 - 3. Cost changes resulting from proposed substitutions shall be clearly stated with the initial substitution proposal. Subsequently discovered costs resulting from the substitution shall be borne by Contractor.

1.6 TRANSPORTATION AND HANDLING

- A. Transport products by methods to avoid product damage; deliver in undamaged condition in manufacturer's unopened containers or packaging, dry.
- B. Provide equipment and personnel to handle products by methods to prevent

soiling or damage.

- C. Promptly inspect shipments to assure that products comply with requirements, quantities are correct, and products are undamaged.
- D. Deliver products in the manufacturer's sealed container or other packaging system, complete with labels and instructions for handling, storing, unpacking, protecting and installing.

1.7 STORAGE AND PROTECTION

- A. Store Products in accordance with manufacturer's instructions, with seals and labels intact and legible.
- B. Store sensitive products in weathertight enclosures; maintain within temperature and humidity ranges required by manufacturer's instructions.
- C. For exterior storage of fabricated products, place on sloped supports above ground. Cover products subject to deterioration with impervious sheet covering; provide ventilation to avoid condensation.
- D. Store loose granular materials on solid surfaces in a well-drained area; prevent mixing with foreign matter.
- E. Arrange storage to provide access for inspection, periodically inspect to assure products are undamaged and are maintained under required conditions.
- F. After installation, provide covering to protect products from damage from traffic and construction operations, remove when no longer needed.

1.8 PROCEDURES

- A. Procedures for Selecting Products: Contractor's options for selecting products are limited by Contract Document requirements and governing regulations, and are not controlled by industry traditions or procedures experienced by Contractor on previous construction projects.
 - 1. Single Product/Manufacturer Name:
 - a. Provide product indicated. Do not offer to provide an unnamed product unless it has been accepted under substitution provisions listed below.
 - b. Except as otherwise indicated, "Named" is defined to mean manufacturer's name for product as recorded in latest issue of published product literature as of date of Contract Documents.
 - c. Refer to requests to use products of a later (or earlier) model to Architect for acceptance before proceeding.

2. Two or More Product/Manufacturer Names:
 - a. Provide 1 of the named products, at Contractor's option.
 - b. Do not offer to provide an unnamed product unless it has been accepted under substitution provisions listed below.
3. Performance Requirements:
 - a. Provide products which comply with specific performances indicated and which are recommended by manufacturer (in published product literature or by individual certification) for application indicated.
 - b. Overall performance of a product is implied where product is specified for specific performances.
4. Standards, Codes, and Regulations: Where compliance with an imposed standard, code, or regulation is required, selection from among products which comply with requirements of those standards, codes, and regulations is Contractor's option.
5. Prescriptive Requirements: Provide products which have been produced in accordance with prescriptive requirements, using specified ingredients and components, and complying with specified requirements for mixing, fabricating, curing, finishing, testing, and similar operations in manufacturing process.
6. Visual Matching:
 - a. Where matching of an established sample is required, final judgment of whether a product proposed by Contractor matches sample satisfactorily is Architect's judgment.
 - b. Where no product exists within specified cost category, which matches sample satisfactorily and complies with requirements, comply with provisions concerning, substitutions and change orders for selection of an equivalent product.
7. Visual Selection:
 - a. Where specified product requirements include "color(s), pattern(s), texture(s), etc. selected by Architect" or words of similar effect, selection of manufacturer and basic product (complying with requirements) is Contractor's option, and subsequent selection of color(s), pattern(s), and texture(s), etc. is Architect's selection.
 - b. Where specified product requirements include "color(s), pattern(s), texture(s), etc., to match Architect's sample" or words to that effect, selection of product (complying with requirements, and within established cost category) is Architect's selection, including designation of manufacturer where necessary to obtain desired

color, pattern, or texture.

1.9 SUBSTITUTION PROCEDURES

- A. Prior (-to-Bid) Approvals: Substitute products, materials, appliances, equipment, fixtures, or systems will be considered by Architect.
1. Any bidder, material supplier, or manufacturer desiring to propose substitution(s) shall:
 - a. Submit in a sealed envelope catalog cuts, shop drawings, or other descriptive literature for products, materials, appliances, equipment, fixtures, or systems for proposed substitution.
 - b. Submit not later than 14 calendar days before bid opening
 1. Make request to Architect in triplicate on copies of Request for Substitution form included at end of this Section.
 2. Submittal(s) shall include a complete and adequate analysis showing point-for-point comparison to specified item(s) or system(s) and must prove equality or superiority.
 3. Include related Section and Drawing number(s), and fully document compliance with requirements for substitutions.
 4. Include product data/drawings, description of methods, samples.
 - a. Where applicable, statement of effect on construction time and coordination with other affected Work.
 - b. Cost information for proposal.
 5. Include identification of previous use locally with dates and names of Architect and Owner.
 6. Anything less will not be considered.
 7. Equivalency:
 - a. The Architect will be the initial judge of equivalency of proposed substitution(s).
 - b. Architect will make written recommendation of acceptance or rejection to Owner.
 8. Satisfaction:
 - a. Prior to proposing substitution(s), certify that item or system is equal to that specified.

- b. That it will fit into space allocated.
 - c. That item affords comparable ease of operation, maintenance, and service.
 - d. That appearance, longevity, and suitability for climate and use are comparable to item specified.
 - e. That substitution is in Owner's interest.
9. Manufacturer's data which is readily available to Architect is not acceptable for establishing proof of quality.
- a. Provide laboratory test data performed by a nationally recognized independent testing laboratory known for its testing expertise.
 - b. Laboratory test shall include types of materials used in substitute item or system, including their thickness and strength, and a direct comparison to item or system specified for capacities, capabilities, coatings, functions, life cycle usage, and operations.
 - c. No change in Architect's design intent will be allowed where item or system will be exposed and where it will be used.
10. Proof: Burden of proof that a proposed substitution is equal or equivalent to a specified item or system shall be upon Contractor, who shall support his request with sufficient test data, samples, brochures, and other means to permit Architect to make a fair and equitable decision on merits of proposal.
11. Based on Architect's written recommendation of acceptance or rejection, Owner will determine acceptability of proposed substitutions.
12. Architect will notify Bidders of Owner's acceptance not later than 5 calendar days prior to bid opening via an addendum to the Contract Documents listing only accepted substitutions.
13. Responsibility: Acceptance of substitutions shall not relieve Contractor from responsibility for complying with all other requirements of the Contract Documents and coordinating substitution(s) with adjacent materials and other affected equipment.
- B. During Construction:
1. Substitutions will not be considered when they are indicated or implied on submittals without separate written request prior to submittal, or when acceptance will require substantial revision of Contract Documents.
 2. Architect and Owner will consider requests from Contractor during construction for substitutions (following procedures outlined above for prior approvals) only under 1 or more of the following conditions:

- a. Substitution is required for compliance with subsequent interpretation of code requirements or insurance regulations.
- b. Shown or specified item or system cannot be provided within Contract Time or becomes unavailable due to no fault of Contractor.
- c. Subsequent information disclosed inability of item(s) or system(s) to perform properly or to fit in designated space, or manufacturer(s) refuse(s) to certify or warrant performance as required.
- d. When, in Architect's judgment, a substitution would be substantially in Owner's best interests in terms of cost (substantial credit), time, or other valuable considerations, after deducting offsetting responsibilities Owner may be required to bear, including additional compensation to Architect for evaluation and redesign services, increased cost of other work by Owner or separate contractors, and similar considerations.

PART 2 - PRODUCTS
Not used.

PART 3 - EXECUTION
Not used.

END OF SECTION

REQUEST FOR SUBSTITUTION

A. Completed reproduction of this form shall accompany all requests for substitutions. Failure to submit form with request shall be cause for rejection. Substituted items or systems may be incorporated into the Work only after receipt of Owner's written approval. Fill in all applicable spaces and cross out all nonapplicable information bracketed ([]) or unbracketed.

[Subcontractor:] [Material Supplier:] [Manufacturer:] Date:
Requested Substitution:
Reference: Specification Section _____ Drawing Reference _____
Reason for Substitution: [Prior Approval] [During Construction]:

B. Resulting Change to Contract Amount: [Add] [Deduct] _____
(Include supporting documentation.)

C. For substitutions made during construction the Architect will, upon receipt of substitution proposal, fill in the following compensation information, add it to or deduct it from the Change to the Contract Amount and submit Net Change to Contract Amount to Owner for approval. Upon receipt of Owner's approval, Architect will proceed with substitution review.

D. Architect's Fee for Substitution Evaluation: _____

E. Architect's Fee for Changes to Contract: _____

F. Documents Due to Substitution:
Net Change to Contract Amount (B + C + D): [Add] [Deduct]
Resulting Change to Contract Time: Add _____ Deduct _____
Summary of Related Work Requiring Coordination (if any):

(Contractor shall assume responsibility for complete coordination with Work of all trades involved if Substitution Request is approved.)

G. Attached Documentation: The following is herewith attached to provide complete documentation of requested substitution:

[] Product Data [] Samples [] Shop Drawings
[] Test Reports [] Other:

H. Contractor's Signature

Subcontractor's/Supplier's/Manufacturer's
Signature

SECTION 01 76 00- GUARANTIES AND WARRANTIES

PART 1 - GENERAL

1.1 SUMMARY

- A. This Section includes requirements for guaranties and warranties for contract closeout and during specified guaranty/warranty periods.

1.2 DESCRIPTION OF REQUIREMENTS

- A. General Limitations: It is recognized that specific guaranties and warranties are intended to protect Owner against failure of the Work to perform as required, and against deficient, defective, and faulty materials and workmanship, regardless of sources.
- B. Related Damages and Losses: When correcting guaranteed or warranted work which has failed, remove and replace other Work of Project which has been damaged as a result of such failure or which must be removed and replaced to provide access for correction of Work.
- C. Reinstatement of Guaranty or Warranty Period: In addition to requirements in the General Conditions, when Work covered by a special project guaranty or product warranty has failed and has been corrected by replacement or restoration, reinstate guaranty or warranty by written endorsement for 1 year starting on date of acceptance of replaced or restored Work.
- D. Replacement Cost, Obligations: Except as otherwise indicated, cost of replacing or restoring failing guaranties or warranted units or products is Contractor's obligation, without regard for whether Owner has already benefitted from use through a portion of anticipated useful service lives.
- E. Rejection of Warranties: Owner reserves the right, at time of Substantial Completion or thereafter, to reject coincidental product warranties submitted by Contractor, which in opinion of Owner detract from or confuse interpretation of requirements of Contract Documents.
- F. Contractor's Procurement Obligations: Do not purchase, subcontract for, or allow others to purchase or subcontract for materials or units of Work for Project where a special project guaranty, specified product warranty, certification, or similar commitment is required until it has been determined that entities required to sign or countersign such commitments are willing to do so.
- G. Specific Guaranty or Warranty Forms: Where a special project guaranty or specified project warranty is required, prepare a written document to contain terms and appropriate identification; ready for execution by required parties.
 - 1. A sample form is attached as the last article of this Section.
 - 2. Refer to individual sections of Divisions 2 through 33 for specific content and requirements.

3. Submit draft to Owner for approval prior to final executions.

1.3 REQUIREMENTS INCLUDED

- A. Compile specified warranties.
- B. Compile specified service and maintenance contracts.
- C. Co-execute submittals when so specified.
- D. Review submittals to verify compliance with Contract Documents.
- E. Submit to Architect for review and transmittal to Owner.

1.4 SUBMITTAL REQUIREMENTS

- A. Assemble warranties, bonds, and service and maintenance contracts, executed by each of the respective manufacturers, suppliers, and subcontractors.
- B. Number of original signed copies required: 2 each.
- C. Table of Contents: Neatly typed, in orderly sequence. Provide complete index information for each item.
 1. Product or work item with index number to bound item.
 2. Firm, with name of principal, address, and telephone number.
 3. Scope.
 4. Date of beginning of warranty, bond or service and maintenance contract.
 5. Duration of warranty, bond, or service maintenance contract.
 6. Provide information for Owner's personnel:
 - a. Procedure to be followed in case of failure.
 - b. Circumstances which might affect the validity of warranty or bond.
 7. Contractor, name of responsible principal, address and telephone number.

1.5 FORM OF SUBMITTALS

- A. Prepare in duplicate packets.
- B. Format:
 1. Size 8-1/2 x 11 inches on punched sheets for standard 3-ring binder.

- a. Fold larger sheets to fit into binders.
2. Warranty-Guaranty wording shall be as printed below.
3. Cover: Identify each packet with typed or printed title "GUARANTIES AND WARRANTIES". List:
 - a. Title of Project.
 - b. Name of Contractor.
- C. Binders: Commercial quality, 3-ring, with durable and cleanable plastic covers.

1.6 TIME OF SUBMITTALS

- A. Make submittals within 10 days after date of Substantial Completion prior to final request for payment.
- B. For items or work, where acceptance is delayed materially beyond Date of Substantial Completion, provide updated submittal within 10 days after acceptance, listing date of acceptance as start of warranty period.

1.7 SUBMITTALS REQUIRED

- A. Submit warranties, bonds, service and maintenance contracts as specified in respective Sections of Specifications and as follows:
 1. Provide when noted in individual Sections of the Project Manual Divisions 2 through 33.

1.8 SAMPLE FORM OF WARRANTY-GUARANTY

- A. Print or type Warranty-Guaranty on installing contractor's own letterhead.
- B. Wording and signatures required.

PART 2 - PRODUCTS

Not used.

PART 3 - EXECUTION

Not used.

A. GUARANTEE-WARRANTY

When required by the specifications, warranties and/or guarantees other than one year shall be in the form of the following on the Contractor's own letterhead:

"GUARANTEE-WARRANTY FOR INTERMOUNTAIN HEALTHCARE, **Logan Regional Hospital Reconfiguration - ASC** project.

We hereby warrant and the General Contractor and/or Material Manufacturer guarantee that the (name of product, equipment or system) that we have installed in the **Logan Regional Hospital Reconfiguration - ASC** project, has been done in accordance with the Contract Documents and that the work as installed will fulfill the requirements of the guaranty-warranty included in the specifications. We agree to repair or replace any or all of our work, together with any other adjacent work which may be displaced by so doing, that may prove to be defective in its workmanship or material within a period of _____ years from the date of Substantial Completion, without any expense whatsoever to the Owner, ordinary wear and tear and unusual abuse or neglect excepted.

In the event of our failure to comply with the above mentioned conditions within sixty (60) days after being notified in writing by the Owner, we collectively or separately do hereby authorize the Owner to proceed to have said defects repaired and made good at our expense, and we will honor and pay the costs and charges therefore upon demand.

Signed _____ Countersigned _____
(Subcontractor) (General Contractor)

Name _____ Name _____
(Print) (Print)

Company _____ Company _____

Address _____ Address _____

License No. _____ License No. _____

Countersigned _____
(Material Manufacturer)

Name _____

Company _____

Address _____

END OF SECTION

SECTION 01 78 23 – OPERATION AND MAINTENANCE DATA

PART 1 - GENERAL

PART 2 - RELATED DOCUMENTS

- A. Drawings and general provisions of the Contract, including General and Supplementary Conditions and other Division 1 Specification Sections, apply to this Section.

2.2 SUMMARY

- A. This Section includes administrative and procedural requirements for preparing operation and maintenance manuals, including the following:
 - 1. Operation and maintenance documentation directory.
 - 2. Emergency manuals.
 - 3. Operation manuals for systems, subsystems, and equipment.
 - 4. Maintenance manuals for the care and maintenance of products, materials, and finishes.
- B. Related Sections include the following:
 - 1. Division 1 Section "Submittal Procedures" for submitting copies of submittals for operation and maintenance manuals.
 - 2. Division 1 Section "Project Record Documents" for preparing Record Drawings for operation and maintenance manuals.
 - 3. Divisions 2 through 33 Sections for specific operation and maintenance manual requirements for the Work in those Sections.

2.3 DEFINITIONS

- A. System: An organized collection of parts, equipment, or subsystems united by regular interaction.
- B. Subsystem: A portion of a system with characteristics similar to a system.

2.4 SUBMITTALS

- A. Final Submittal: Submit one copy one of each manual in final form at least 15 days before final inspection. Architect will return copy with comments within 15 days after final inspection.
 - 1. Correct or modify each manual to comply with Architect's comments. Submit 3 copies of each corrected manual within 15 days of receipt of Architect's comments.

2.5 COORDINATION

- A. Where operation and maintenance documentation includes information on installations by more than one factory-authorized service representative, assemble and coordinate information furnished by representatives and prepare manuals.

PART 3 - OPERATION AND MAINTENANCE DOCUMENTATION DIRECTORY

- A. Organization: Include a section in the directory for each of the following:
 - 1. List of documents.
 - 2. List of systems.
 - 3. List of equipment.
 - 4. Table of contents.
- B. List of Systems and Subsystems: List systems alphabetically. Include references to operation and maintenance manuals that contain information about each system.
- C. List of Equipment: List equipment for each system, organized alphabetically by system. For pieces of equipment not part of system, list alphabetically in separate list.
- D. Tables of Contents: Include a table of contents for each emergency, operation, and maintenance manual.
- E. Identification: In the documentation directory and in each operation and maintenance manual, identify each system, subsystem, and piece of equipment with same designation used in the Contract Documents. If no designation exists, assign a designation according to ASHRAE Guideline 4, "Preparation of Operating and Maintenance Documentation for Building Systems."

3.2 MANUALS, GENERAL

- A. Organization: Unless otherwise indicated, organize each manual into a separate section for each system and subsystem, and a separate section for each piece of equipment not part of a system. Each manual shall contain the following materials, in the order listed:
 - 1. Title page.
 - 2. Table of contents.
 - 3. Manual contents.
- B. Title Page: Enclose title page in transparent plastic sleeve. Include the following information:
 - 1. Subject matter included in manual.
 - 2. Name and address of Project.
 - 3. Name and address of Owner.
 - 4. Date of submittal.
 - 5. Name, address, and telephone number of Contractor.
 - 6. Cross-reference to related systems in other operation and maintenance manuals.

- C. Table of Contents: List each product included in manual, identified by product name, indexed to the content of the volume, and cross-referenced to Specification Section number in Project Manual.
1. If operation or maintenance documentation requires more than one volume to accommodate data, include comprehensive table of contents for all volumes in each volume of the set.
- D. Manual Contents: Organize into sets of manageable size. Arrange contents alphabetically by system, subsystem, and equipment. If possible, assemble instructions for subsystems, equipment, and components of one system into a single binder.
1. Binders/Maintenance Manuals: Organize operation and maintenance data into suitable sets of manageable size. Binders shall be Red Buckram binders with easy view metal for sheet size 11" X 8 ½" with expandable metal capacity as required for the project, rivet through construction with library corners using #12 BB and lining with same materials as cover, front cover and back-bone foil stamped in white. Binders shall be as manufactured by Hiller Bookbinding or equal. The master index sheet and each tabbed index sheet shall be AICO Gold-Line indexes or equal. Mark appropriate identification on front spine of each binder. Include the following types of information:
 - a. If two or more binders are necessary to accommodate data of a system, organize data in each binder into groupings by subsystem and related components. Cross-reference other binders if necessary to provide essential information for proper operation or maintenance of equipment or system.
 - b. Identify each binder on front and spine, with printed title "OPERATION AND MAINTENANCE MANUAL," Project title or name, and subject matter of contents. Indicate volume number for multiple-volume sets.
 2. Protective Plastic Sleeves: Transparent plastic sleeves designed to enclose diagnostic software diskettes for computerized electronic equipment.
 3. Drawings: Attach reinforced, punched binder tabs on drawings and bind with text.
 - a. If oversize drawings are necessary, fold drawings to same size as text pages and use as foldouts.
 - b. If drawings are too large to be used as foldouts, fold and place drawings in labeled envelopes and bind envelopes in rear of manual. At appropriate locations in manual, insert typewritten pages indicating drawing titles, descriptions of contents, and drawing locations.

3.3 EMERGENCY MANUALS

- A. Content: Organize manual into a separate section for each of the following:
1. Type of emergency.
 2. Emergency instructions.
 3. Emergency procedures.

- B. Type of Emergency: Where applicable for each type of emergency indicated below, include instructions and procedures for each system, subsystem, piece of equipment, and component:
1. Fire.
 2. Flood.
 3. Gas leak.
 4. Water leak.
 5. Power failure.
 6. Water outage.
 7. System, subsystem, or equipment failure.
 8. Chemical release or spill.
- C. Emergency Instructions: Describe and explain warnings, trouble indications, error messages, and similar codes and signals. Include responsibilities of Owner's operating personnel for notification of Installer, supplier, and manufacturer to maintain warranties.
- D. Emergency Procedures: Include the following, as applicable:
1. Instructions on stopping.
 2. Shutdown instructions for each type of emergency.
 3. Operating instructions for conditions outside normal operating limits.
 4. Required sequences for electric or electronic systems.
 5. Special operating instructions and procedures.

3.4 OPERATION MANUALS

- A. Content: In addition to requirements in this Section, include operation data required in individual Specification Sections and the following information:
1. System, subsystem, and equipment descriptions.
 2. Performance and design criteria if Contractor is delegated design responsibility.
 3. Operating standards.
 4. Operating procedures.
 5. Operating logs.
 6. Wiring diagrams.
 7. Control diagrams.
 8. Piped system diagrams.
 9. Precautions against improper use.
 10. License requirements including inspection and renewal dates.
- B. Descriptions: Include the following:
1. Product name and model number.
 2. Manufacturer's name.
 3. Equipment identification with serial number of each component.
 4. Equipment function.
 5. Operating characteristics.
 6. Limiting conditions.
 7. Performance curves.
 8. Engineering data and tests.
 9. Complete nomenclature and number of replacement parts.

- C. Operating Procedures: Include the following, as applicable:
 - 1. Startup procedures.
 - 2. Equipment or system break-in procedures.
 - 3. Routine and normal operating instructions.
 - 4. Regulation and control procedures.
 - 5. Instructions on stopping.
 - 6. Normal shutdown instructions.
 - 7. Seasonal and weekend operating instructions.
 - 8. Required sequences for electric or electronic systems.
 - 9. Special operating instructions and procedures.
- D. Systems and Equipment Controls: Describe the sequence of operation, and diagram controls as installed.
- E. Piped Systems: Diagram piping as installed, and identify color-coding where required for identification.

3.5 PRODUCT MAINTENANCE MANUAL

- A. Content: Organize manual into a separate section for each product, material, and finish. Include source information, product information, maintenance procedures, repair materials and sources, and warranties and bonds, as described below.
- B. Source Information: List each product included in manual, identified by product name and arranged to match manual's table of contents. For each product, list name, address, and telephone number of Installer or supplier and maintenance service agent, and cross-reference Specification Section number and title in Project Manual.
- C. Product Information: Include the following, as applicable:
 - 1. Product name and model number.
 - 2. Manufacturer's name.
 - 3. Color, pattern, and texture.
 - 4. Material and chemical composition.
 - 5. Reordering information for specially manufactured products.
- D. Maintenance Procedures: Include manufacturer's written recommendations and the following:
 - 1. Inspection procedures.
 - 2. Types of cleaning agents to be used and methods of cleaning.
 - 3. List of cleaning agents and methods of cleaning detrimental to product.
 - 4. Schedule for routine cleaning and maintenance.
 - 5. Repair instructions.
- E. Repair Materials and Sources: Include lists of materials and local sources of materials and related services.
- F. Warranties and Bonds: Include copies of warranties and bonds and lists of circumstances and conditions that would affect validity of warranties or bonds.

1. Include procedures to follow and required notifications for warranty claims.

3.6 SYSTEMS AND EQUIPMENT MAINTENANCE MANUAL

- A. Content: For each system, subsystem, and piece of equipment not part of a system, include source information, manufacturers' maintenance documentation, maintenance procedures, maintenance and service schedules, spare parts list and source information, maintenance service contracts, and warranty and bond information, as described below.
- B. Source Information: List each system, subsystem, and piece of equipment included in manual, identified by product name and arranged to match manual's table of contents. For each product, list name, address, and telephone number of Installer or supplier and maintenance service agent, and cross-reference Specification Section number and title in Project Manual.
- C. Manufacturers' Maintenance Documentation: Manufacturers' maintenance documentation including the following information for each component part or piece of equipment:
 1. Standard printed maintenance instructions and bulletins.
 2. Drawings, diagrams, and instructions required for maintenance, including disassembly and component removal, replacement, and assembly.
 3. Identification and nomenclature of parts and components.
 4. List of items recommended to be stocked as spare parts.
- D. Maintenance Procedures: Include the following information and items that detail essential maintenance procedures:
 1. Test and inspection instructions.
 2. Troubleshooting guide.
 3. Precautions against improper maintenance.
 4. Aligning, adjusting, and checking instructions.
 5. Demonstration and training videotape, if available.
- E. Maintenance and Service Schedules: Include service and lubrication requirements, list of required lubricants for equipment, and separate schedules for preventive and routine maintenance and service with standard time allotment.
 1. Scheduled Maintenance and Service: Tabulate actions for daily, weekly, monthly, quarterly, semiannual, and annual frequencies.
 2. Maintenance and Service Record: Include manufacturers' forms for recording maintenance.
- F. Spare Parts List and Source Information: Include lists of replacement and repair parts, with parts identified and cross-referenced to manufacturers' maintenance documentation and local sources of maintenance materials and related services.
- G. Warranties and Bonds: Include copies of warranties and bonds and lists of circumstances and conditions that would affect validity of warranties or bonds.
 1. Include procedures to follow and required notifications for warranty claims.

EXECUTION

3.7 MANUAL PREPARATION

- A. Emergency Manual: Assemble a complete set of emergency information indicating procedures for use by emergency personnel and by Owner's operating personnel for types of emergencies indicated.
- B. Product Maintenance Manual: Assemble a complete set of maintenance data indicating care and maintenance of each product, material, and finish incorporated into the Work.
- C. Operation and Maintenance Manuals: Assemble a complete set of operation and maintenance data indicating operation and maintenance of each system, subsystem, and piece of equipment not part of a system.
 - 1. Engage a factory-authorized service representative to assemble and prepare information for each system, subsystem, and piece of equipment not part of a system.
 - 2. Prepare a separate manual for each system and subsystem, in the form of an instructional manual for use by Owner's operating personnel.
- D. Manufacturers' Data: Where manuals contain manufacturers' standard printed data, include only sheets pertinent to product or component installed. Mark each sheet to identify each product or component incorporated into the Work. If data include more than one item in a tabular format, identify each item using appropriate references from the Contract Documents. Identify data applicable to the Work and delete references to information not applicable.
 - 1. Prepare supplementary text if manufacturers' standard printed data are not available and where the information is necessary for proper operation and maintenance of equipment or systems.
- E. Drawings: Prepare drawings supplementing manufacturers' printed data to illustrate the relationship of component parts of equipment and systems and to illustrate control sequence and flow diagrams. Coordinate these drawings with information contained in Record Drawings to ensure correct illustration of completed installation.
 - 1. Do not use original Project Record Documents as part of operation and maintenance manuals.
 - 2. Comply with requirements of newly prepared Record Drawings in Division 1 Section "Project Record Documents."
- F. Comply with Division 1 Sections for schedule for submitting operation and maintenance documentation.

END OF SECTION

SECTION 01 78 39 – PROJECT RECORD DOCUMENTS

PART 1 - GENERAL

1.1 RELATED DOCUMENTS

- A. Drawings and general provisions of the Contract, including General and Supplementary Conditions and other Division 1 Specification Sections, apply to this Section.

1.2 SUMMARY

- A. This Section includes administrative and procedural requirements for Project Record Documents, including the following:
 - 1. Record Drawings.
 - 2. Record Specifications.
 - 3. Record Product Data.
- B. Related Sections include the following:
 - 1. Division 1 Section for general closeout procedures.
 - 2. Division 1 Section "Operation and Maintenance Data" for operation and maintenance manual requirements.
 - 3. Divisions 2 through 33 Sections for specific requirements for Project Record Documents of the Work in those Sections.

1.3 SUBMITTALS

- A. Record Drawings: Comply with the following:
 - 1. Number of Copies: Submit one set(s) of marked-up Record Prints.
 - a. Final Submittal: Submit one set(s) of marked-up Record Prints showing modifications for trades involved in the project.
- B. Record Specifications: Submit one copy of Project's Specifications, including addenda and contract modifications.
- C. Record Product Data: Submit one copy of each Product Data submittal.
 - 1. Where Record Product Data is required as part of operation and maintenance manuals, submit marked-up Product Data as an insert in manual instead of submittal as Record Product Data.

PART 2 - PRODUCTS

2.1 RECORD DRAWINGS

- A. Record Prints: Maintain one set of blue- or black-line white prints of the Contract Drawings and Shop Drawings.
1. Preparation: Mark Record Prints to show the actual installation where installation varies from that shown originally. Require individual or entity who obtained record data, whether individual or entity is Installer, subcontractor, or similar entity, to prepare the marked-up Record Prints.
 - a. Give particular attention to information on concealed elements that would be difficult to identify or measure and record later.
 - b. Accurately record information in an understandable drawing technique.
 - c. Record data as soon as possible after obtaining it. Record and check the markup before enclosing concealed installations.
 2. Content: Types of items requiring marking include, but are not limited to, the following:
 - a. Dimensional changes to Drawings.
 - b. Revisions to details shown on Drawings.
 - c. Depths of foundations below first floor.
 - d. Locations and depths of underground utilities.
 - e. Revisions to routing of piping and conduits.
 - f. Revisions to electrical circuitry.
 - g. Actual equipment locations.
 - h. Duct size and routing.
 - i. Locations of concealed internal utilities.
 - j. Changes made following Architect's written orders.
 - k. Details not on the original Contract Drawings.
 - l. Field records for variable and concealed conditions.
 3. Mark the Contract Drawings or Shop Drawings, whichever is most capable of showing actual physical conditions, completely and accurately. If Shop Drawings are marked, show cross-reference on the Contract Drawings.
 4. Mark record sets with erasable, red-colored pencil. Use other colors to distinguish between changes for different categories of the Work at same location.
 5. Mark important additional information that was either shown schematically or omitted from original Drawings.
 6. Note Construction Change Directive numbers, alternate numbers, Change Order numbers, and similar identification, where applicable.

2.2 RECORD SPECIFICATIONS

- A. Preparation: Mark Specifications to indicate the actual product installation where installation varies from that indicated in Specifications, addenda, and contract modifications.

1. Give particular attention to information on concealed products and installations that cannot be readily identified and recorded later.

2.3 MISCELLANEOUS RECORD SUBMITTALS

- A. Assemble miscellaneous records required by other Specification Sections for miscellaneous record keeping and submittal in connection with actual performance of the Work. Bind or file miscellaneous records and identify each, ready for continued use and reference.

PART 3 - EXECUTION

3.1 RECORDING AND MAINTENANCE

- A. Recording: Maintain one copy of each submittal during the construction period for Project Record Document purposes. Post changes and modifications to Project Record Documents as they occur; do not wait until the end of Project.
- B. Maintenance of Record Documents and Samples: Store Record Documents and Samples in the field office apart from the Contract Documents used for construction. Do not use Project Record Documents for construction purposes. Maintain Record Documents in good order and in a clean, dry, legible condition, protected from deterioration and loss. Provide access to Project Record Documents for Architect's reference during normal working hours.

END OF SECTION

SECTION 01 79 00- CLEANING

PART 1 - GENERAL

1.1 SUMMARY

- A. Work Included: Requirements for periodic, general, and final cleaning of the project.
- B. Provide temporary and periodic clean-up of extra materials, waste and general debris during construction of the work, together with the final clean-up and cleaning, polishing and other "housekeeping" required to bring various surfaces to an acceptable condition prior to final inspection, or before additional work is done during construction.
- C. This Section includes requirements for Cleaning for all phases of the Project. Some requirements of this Section may not be applicable to individual project Phases.

1.2 GENERAL REQUIREMENTS

- A. Maintain premises and public properties free from accumulations of waste, debris, and rubbish in accordance with applicable safety and insurance standards and local ordinances.
- B. The acceptable level of cleanliness of the Project shall be the decision of the Architect.
 - 1. Work necessary to achieve such acceptable state shall be performed when required.
- C. Burning: Burning of waste materials and/or rubbish on Site is not permitted.

1.3 CLEAN-UP DURING CONSTRUCTION

- A. During construction, provide cleaning-up as follows:
 - 1. Maintain areas free of waste materials, debris, and rubbish. Maintain site in a clean and orderly condition.
 - 2. Remove debris and rubbish from pipe chases, plenums, down spouts, attics, crawl spaces, and other closed or remote spaces, prior to enclosing the space.
 - 3. Broom and vacuum clean interior areas prior to start of surface finishing, and continue cleaning to eliminate dust.
 - 4. Remove waste materials, debris, and rubbish from site weekly, or more often if needed, and dispose off-site in compliance with local regulations.

5. Storage areas: Ensure that materials to be used for construction are stored in designated structures or areas by the appropriate trades. Maintain such areas or structures in a clean condition for the life of the Project.
6. Containers: Provide appropriate containers, such as dump containers, and locate on site for collection of waste materials and rubbish.
7. Supervision: Oversee all cleaning of areas by the trades using them. Ensure that resulting accumulations are deposited in appropriate containers.
8. Clean-up: Daily, weekly, or as necessary, clean-up floors and Site areas. Remove all loose materials, by sweeping if necessary.

1.4 FINAL CLEANING

- A. Provide final clean-up and polishing just prior to final inspection and/or acceptance of the work of the Project.
- B. Preparation:
 1. Prior to final inspection, remove all loose material of any nature, except spare parts, loose furniture or furnishings, manuals, parts books, and similar items.
 2. Remove all temporary buildings, utility lines or pipes and other work of a temporary nature.
 3. Remove all temporary wrappings. Leave no trace of wrap or adhesive.
- C. Surface Cleaning:
 1. Special cleaning for specific units of Work as specified and as shown on Drawings.
 2. Provide final cleaning of the Work, at time indicated, consisting of cleaning each surface or unit of Work to normal "clean" condition expected for a first-class building cleaning and maintenance program.
 3. Comply with manufacturer's instructions for cleaning operations.
- D. The following are examples, but not by way of limitation, of cleaning levels required:
 1. Remove labels which are not required as permanent labels.
 2. Clean transparent materials, including mirrors and window/door glass, to a polished condition, removing substances which are noticeable as vision-obscuring materials. Replace broken glass and damaged

- transparent materials.
3. Clean exposed exterior and interior hard-surfaced finishes to a dirt-free condition, free of dust, stains, films, and similar noticeable distracting substances.
 - a. Except as otherwise indicated, avoid disturbance of natural weathering of exterior surfaces.
 - b. Restore reflective surfaces to original reflective condition.
 4. Wipe surfaces of mechanical and electrical equipment clean, including elevator equipment and similar equipment; remove excess lubrication and other substances.
 5. Remove debris and surface dust from limited-access spaces including roofs, plenums, shafts, trenches, equipment vaults, manholes, attics, and similar spaces.
 6. Clean concrete floors in unoccupied spaces broom clean.
 7. Vacuum clean carpeted surfaces and similar soft surfaces.
 8. Clean plumbing fixtures to a sanitary condition, free of stains including those resulting from water exposure.
 9. Clean light fixtures and lamps so as to function with full efficiency.
 10. Clean Project Site (staging areas, Contractor Parking areas), including landscape development areas, of litter and foreign substances.
 11. Sweep paved areas to a broom-clean condition; remove stains, petro-chemical spills, and other foreign deposits.
- E. Pest Control: Engage an experienced exterminator to make a final inspection of Project, and to rid Project of rodents, insects, and other pests.
- F. Removal of Protection: Except as otherwise indicated or requested by Hospital Representative, remove temporary protection devices and facilities which were installed during course of Work to protect previously completed Work during remainder of construction period.
- G. Compliances:
1. Comply with safety standards and governing regulations for cleaning operations.
 2. Do not burn waste materials at site, or bury debris or excess materials on the property, or discharge volatile or other harmful or dangerous materials into drainage systems.

3. Remove waste materials from site and dispose of in a lawful manner.
- H. Moving Parts: Lubricate moving parts as recommended by the parts manufacturer, or as directed by the Architect. Wipe clean, all surplus lubricants.
- I. Protection: Protect finished floors from damage due to traffic or other causes.

END OF SECTION

SECTION 02 41 19 - SELECTIVE DEMOLITION

PART 1 - GENERAL

1.1 RELATED DOCUMENTS

- A. Drawings and general provisions of the Contract, including General and Supplementary Conditions and other Division 1 Specification Sections, apply to this Section.

1.2 SUMMARY

- A. This Section includes the following:
 - 1. Demolition and removal of selected portions of a building or structure.
 - 2. Repair procedures for selective demolition operations.

1.3 DEFINITIONS

- A. Remove: Carefully detach items from existing construction and legally dispose of them off-site, unless indicated to be removed and salvaged or removed and reinstalled.
- B. Remove and Reinstall: Detach items from existing construction, prepare them for reuse, and reinstall them where indicated.
- C. Existing to Remain: Existing items of construction that are not to be removed and that are not otherwise indicated to be removed, removed and salvaged, or removed and reinstalled.

1.4 MATERIALS OWNERSHIP

- A. Except for items or materials indicated to be reused, salvaged, reinstalled, or otherwise indicated to remain Owner's property, demolished materials shall become Contractor's property and shall be removed from Project site.

1.5 SUBMITTALS

- A. Proposed Dust-Control and Noise-Control Measures: Submit statement or drawing that indicates the measures proposed for use, proposed locations, and proposed time frame for their operation. Identify options if proposed measures are later determined to be inadequate.

1.6 PROJECT CONDITIONS

- A. Owner will occupy portions of building immediately adjacent to selective demolition area. Conduct selective demolition so Owner's operations will not be disrupted. Provide not less than 72 hours' notice to Owner of activities that will affect Owner's operations.

- B. Maintain access to existing walkways, corridors, and other adjacent occupied or used facilities.
 - 1. Do not close or obstruct walkways, corridors, or other occupied or used facilities without written permission from authorities having jurisdiction.
- C. Owner assumes no responsibility for condition of areas to be selectively demolished.
 - 1. Conditions existing at time of inspection for bidding purpose will be maintained by Owner as far as practical.
- D. Hazardous Materials: It is not expected that hazardous materials will be encountered in the Work.
 - 1. If materials suspected of containing hazardous materials are encountered in the work, Contractor will be responsible for removal and disposal of all materials. A copy of an Asbestos Report will be provided to the Contractor prior to construction beginning. See Bid Proposal for unit price to remove hazardous materials.
- E. Storage or sale of removed items or materials on-site will not be permitted.
- F. Utility Service: Maintain existing utilities indicated to remain in service and protect them against damage during selective demolition operations.
 - 1. Maintain fire-protection facilities in service during selective demolition operations.

PART 2 - PRODUCTS (Not Applicable)

PART 3 - EXECUTION

3.1 EXAMINATION

- A. Verify that utilities have been disconnected and capped.
- B. Survey existing conditions and correlate with requirements indicated to determine extent of selective demolition required.
- C. When unanticipated mechanical, electrical, or structural elements that conflict with intended function or design are encountered, investigate and measure the nature and extent of conflict. Promptly submit a written report to Architect.

3.2 UTILITY SERVICES

- A. Existing Utilities: Maintain services indicated to remain and protect them against damage during selective demolition operations.
- B. Do not interrupt existing utilities serving occupied or operating facilities unless authorized in writing by Owner and authorities having jurisdiction. Provide temporary services during interruptions to existing utilities, as acceptable to Owner and to authorities having jurisdiction.

1. Provide at least 72 hours' notice to Owner if shutdown of service is required during changeover.

- C. Utility Requirements: Locate, identify, disconnect, and seal or cap off indicated utilities serving areas to be selectively demolished.

3.3 PREPARATION

- A. Temporary Enclosures: Provide temporary enclosures for protection of existing building and construction, in progress and completed, from exposure, foul weather, other construction operations, and similar activities. Provide temporary weathertight enclosure for building exterior.

1. Where heating or cooling is needed and permanent enclosure is not complete, provide insulated temporary enclosures. Coordinate enclosure with ventilating and material drying or curing requirements to avoid dangerous conditions and effects.

- B. Temporary Partitions: Erect and maintain dustproof partitions and temporary enclosures to limit dust and dirt migration and to separate areas from fumes and noise.

3.4 SELECTIVE DEMOLITION

- A. General: Demolish and remove existing construction only to the extent required by new construction and as indicated. Use methods required to complete the Work within limitations of governing regulations and as follows:

1. Neatly cut openings and holes plumb, square, and true to dimensions required. Use cutting methods least likely to damage construction to remain or adjoining construction. Use hand tools or small power tools designed for sawing or grinding, not hammering and chopping, to minimize disturbance of adjacent surfaces. Temporarily cover openings to remain.
2. Cut or drill from the exposed or finished side into concealed surfaces to avoid marring existing finished surfaces.
3. Dispose of demolished items and materials promptly.

- B. Existing Facilities: Comply with building manager's requirements for using and protecting building facilities during selective demolition operations.

3.5 DISPOSAL OF DEMOLISHED MATERIALS

- A. General: Promptly dispose of demolished materials. Do not allow demolished materials to accumulate on-site.

- B. Burning: Do not burn demolished materials.

- C. Disposal: Transport demolished materials off Owner's property and legally dispose of them.

END OF SECTION

SECTION 03 10 00 - CONCRETE FORMING AND ACCESSORIES

PART 1 - GENERAL

1.1 SUMMARY

A. Section Includes:

1. Form-facing material for cast-in-place concrete.
2. Shoring, bracing, and anchoring.

1.2 PREINSTALLATION MEETINGS

- A. Preinstallation Conference: Conduct conference at Project site.

1.3 ACTION SUBMITTALS

A. Product Data: For each of the following:

1. Exposed surface form-facing material.
2. Concealed surface form-facing material.
3. Form ties.
4. Form-release agent.

- B. Shop Drawings: Prepared by, and signed and sealed by, a qualified professional engineer responsible for their preparation, detailing fabrication, assembly, and support of forms.

1. For exposed vertical concrete walls, indicate dimensions and form tie locations.
2. Indicate dimension and locations of construction and movement joints required to construct the structure in accordance with ACI 301.

- a. Location of construction joints is subject to approval of the Architect.

1.4 INFORMATIONAL SUBMITTALS

- A. Field quality-control reports.
- B. Minutes of preinstallation conference.

PART 2 - PRODUCTS

2.1 PERFORMANCE REQUIREMENTS

- A. Concrete Formwork: Design, engineer, erect, shore, brace, and maintain formwork, shores, and reshores in accordance with ACI 301, to support vertical, lateral, static, and dynamic loads, and construction loads that might be applied, until structure can support such loads, so that resulting concrete conforms to the required shapes, lines, and dimensions.
1. Design wood panel forms in accordance with APA's "Concrete Forming Design/Construction Guide."
 2. Design formwork to limit deflection of form-facing material to 1/240 of center-to-center spacing of supports.

2.2 FORM-FACING MATERIALS

- A. As-Cast Surface Form-Facing Material:
1. Provide continuous, true, and smooth concrete surfaces.
 2. Furnish in largest practicable sizes to minimize number of joints.
 3. Acceptable Materials: As required to comply with Surface Finish designations specified in Section 033000 "Cast-In-Place Concrete, and as follows:
 - a. Plywood, metal, or other approved panel materials.
 - b. Exterior-grade plywood panels, suitable for concrete forms, complying with DOC PS 1, and as follows:
 - 1) APA HDO (high-density overlay).
 - 2) APA MDO (medium-density overlay); mill-release agent treated and edge sealed.
 - 3) APA Structural 1 Plyform, B-B or better; mill oiled and edge sealed.
 - 4) APA Plyform Class I, B-B or better; mill oiled and edge sealed.
- B. Concealed Surface Form-Facing Material: Lumber, plywood, metal, plastic, or another approved material.
1. Provide lumber dressed on at least two edges and one side for tight fit.

2.3 RELATED MATERIALS

- A. Chamfer Strips: Wood, metal, PVC, or rubber strips, 3/4 by 3/4 inch, minimum.
- B. Rustication Strips: Wood, metal, PVC, or rubber strips, kerfed for ease of form removal.
- C. Form-Release Agent: Commercially formulated form-release agent that does not bond with, stain, or adversely affect concrete surfaces and does not impair subsequent treatments of concrete surfaces.
1. Formulate form-release agent with rust inhibitor for steel form-facing materials.

- D. Form Ties: Factory-fabricated, removable or snap-off, glass-fiber-reinforced plastic or metal form ties designed to resist lateral pressure of fresh concrete on forms and to prevent spalling of concrete on removal.
 - 1. Furnish units that leave no corrodible metal closer than 1 inch to the plane of exposed concrete surface.
 - 2. Furnish ties that, when removed, leave holes no larger than 1 inch in diameter in concrete surface.
 - 3. Furnish ties with integral water-barrier plates to walls indicated to receive dampproofing or waterproofing.

PART 3 - EXECUTION

3.1 INSTALLATION OF FORMWORK

- A. Comply with ACI 301.
- B. Construct formwork, so concrete members and structures are of size, shape, alignment, elevation, and position indicated, within tolerance limits of ACI 117 and to comply with the Surface Finish designations specified in Section 033000 "Cast-In-Place Concrete" for as-cast finishes.
- C. Limit concrete surface irregularities as follows:
 - 1. Surface Finish-2.0: ACI 117 Class B, 1/4 inch.
- D. Construct forms tight enough to prevent loss of concrete mortar.
 - 1. Minimize joints.
 - 2. Exposed Concrete: Symmetrically align joints in forms.
- E. Construct removable forms for easy removal without hammering or prying against concrete surfaces.
 - 1. Provide crush or wrecking plates where stripping may damage cast-concrete surfaces.
 - 2. Provide top forms for inclined surfaces steeper than 1.5 horizontal to 1 vertical.
 - 3. Install keyways, reglets, recesses, and other accessories, for easy removal.
- F. Do not use rust-stained, steel, form-facing material.
- G. Set edge forms, bulkheads, and intermediate screed strips for slabs to achieve required elevations and slopes in finished concrete surfaces.
 - 1. Provide and secure units to support screed strips.
 - 2. Use strike-off templates or compacting-type screeds.
- H. Provide temporary openings for cleanouts and inspection ports where interior area of formwork is inaccessible.
 - 1. Close openings with panels tightly fitted to forms and securely braced to prevent loss of concrete mortar.

2. Locate temporary openings in forms at inconspicuous locations.
- I. Chamfer exterior corners and edges of permanently exposed concrete.
- J. At construction joints, overlap forms onto previously placed concrete not less than 12 inches.
- K. Form openings, chases, offsets, sinkages, keyways, reglets, blocking, screeds, and bulkheads required in the Work.
 1. Determine sizes and locations from trades providing such items.
 2. Obtain written approval of Architect prior to forming openings not indicated on Drawings.
- L. Construction and Movement Joints:
 1. Construct joints true to line with faces perpendicular to surface plane of concrete.
 2. Install so strength and appearance of concrete are not impaired, at locations indicated or as approved by Architect.
 3. Place joints perpendicular to main reinforcement.
- M. Clean forms and adjacent surfaces to receive concrete. Remove chips, wood, sawdust, dirt, and other debris just before placing concrete.
- N. Retighten forms and bracing before placing concrete, as required, to prevent mortar leaks and maintain proper alignment.
- O. Coat contact surfaces of forms with form-release agent, according to manufacturer's written instructions, before placing reinforcement.

3.2 INSTALLATION OF EMBEDDED ITEMS

- A. Place and secure anchorage devices and other embedded items required for adjoining work that is attached to or supported by cast-in-place concrete.
 1. Use setting drawings, templates, diagrams, instructions, and directions furnished with items to be embedded.
 2. Install anchor rods, accurately located, to elevations required and complying with tolerances in Section 7.5 of AISC 303.
 3. Clean embedded items immediately prior to concrete placement.

3.3 SHORING AND RESHORING INSTALLATION

- A. Comply with ACI 318 and ACI 301 for design, installation, and removal of shoring and reshoring.
 1. Do not remove shoring or reshoring until measurement of slab tolerances is complete.

- B. Plan sequence of removal of shores and reshore to avoid damage to concrete. Locate and provide adequate reshoring to support construction without excessive stress or deflection.

3.4 FIELD QUALITY CONTROL

- A. Special Inspections: Owner will engage a special inspector and qualified testing and inspecting agency to perform field tests and inspections and prepare test reports.
- B. Testing Agency: Engage a qualified testing and inspecting agency to perform tests and inspections and to submit reports.
- C. Inspections:
 - 1. Inspect formwork for shape, location, and dimensions of the concrete member being formed.
 - 2. Inspect insulating concrete forms for shape, location, and dimensions of the concrete member being formed.

END OF SECTION 031000

SECTION 03 20 00 - CONCRETE REINFORCING

PART 1 - GENERAL

1.1 SUMMARY

- A. Section Includes:
 - 1. Steel reinforcement bars.
 - 2. Welded-wire reinforcement.

1.2 PREINSTALLATION MEETINGS

- A. Preinstallation Conference: Conduct conference at Project site.

1.3 ACTION SUBMITTALS

- A. Product Data: For the following:
 - 1. Each type of steel reinforcement.
 - 2. Bar supports.
 - 3. Mechanical splice couplers.
- B. Shop Drawings: Comply with ACI SP-066:
 - 1. Include placing drawings that detail fabrication, bending, and placement.
 - 2. Include bar sizes, lengths, materials, grades, bar schedules, stirrup spacing, bent bar diagrams, bar arrangement, location of splices, lengths of lap splices, details of mechanical splice couplers, details of welding splices, tie spacing, hoop spacing, and supports for concrete reinforcement.
- C. Construction Joint Layout: Indicate proposed construction joints required to build the structure.
 - 1. Location of construction joints is subject to approval of the Architect.

1.4 INFORMATIONAL SUBMITTALS

- A. Material Certificates: For each of the following, signed by manufacturers:
 - 1. Epoxy-Coated Reinforcement: CRSI's "Epoxy Coating Plant Certification."
- B. Material Test Reports: For the following, from a qualified testing agency:
 - 1. Steel Reinforcement:
 - 2. Mechanical splice couplers.

- C. Field quality-control reports.
- D. Minutes of preinstallation conference.

1.5 QUALITY ASSURANCE

- A. Welding Qualifications: Qualify procedures and personnel in accordance with AWS D1.4/D 1.4M.

PART 2 - PRODUCTS

2.1 STEEL REINFORCEMENT

- A. Reinforcing Bars: ASTM A615/A615M, Grade 60, deformed.
- B. Epoxy-Coated Reinforcing Bars:
 - 1. Steel Bars: ASTM A615/A615M, Grade 60, deformed bars.
 - 2. Epoxy Coating: ASTM A775/A775M or ASTM A934/A934M with less than 2 percent damaged coating in each 12-inch bar length.
- C. Plain-Steel Welded-Wire Reinforcement: ASTM A1064/A1064M, plain, fabricated from as-drawn steel wire into flat sheets.

2.2 REINFORCEMENT ACCESSORIES

- A. Bar Supports: Bolsters, chairs, spacers, and other devices for spacing, supporting, and fastening reinforcing bars and welded-wire reinforcement in place.
 - 1. Manufacture bar supports from steel wire, plastic, or precast concrete in accordance with CRSI's "Manual of Standard Practice," of greater compressive strength than concrete and as follows:
 - a. For concrete surfaces exposed to view, where legs of wire bar supports contact forms, use CRSI Class 1 plastic-protected steel wire, all-plastic bar supports, or CRSI Class 2 stainless steel bar supports.
 - b. For epoxy-coated reinforcement, use CRSI Class 1A epoxy-coated or other dielectric-polymer-coated wire bar supports.
- B. Steel Tie Wire: ASTM A1064/A1064M, annealed steel, not less than 0.0508 inch in diameter.
 - 1. Finish: Plain except use on epoxy coated bars ASTM A884/A884M, Class A, Type 1, epoxy coated, with less than 2 percent damaged coating in each 12-inch wire length.

2.3 FABRICATING REINFORCEMENT

- A. Fabricate steel reinforcement according to CRSI's "Manual of Standard Practice."

PART 3 - EXECUTION

3.1 PREPARATION

- A. Protection of In-Place Conditions:
 - 1. Do not cut or puncture vapor retarder.
 - 2. Repair damage and reseal vapor retarder before placing concrete.
- B. Clean reinforcement of loose rust and mill scale, earth, ice, and other foreign materials that reduce bond to concrete.

3.2 INSTALLATION OF STEEL REINFORCEMENT

- A. Comply with CRSI's "Manual of Standard Practice" for placing and supporting reinforcement.
- B. Accurately position, support, and secure reinforcement against displacement.
 - 1. Locate and support reinforcement with bar supports to maintain minimum concrete cover.
 - 2. Do not tack weld crossing reinforcing bars.
- C. Preserve clearance between bars of not less than 1 inch, not less than one bar diameter, or not less than 1-1/3 times size of large aggregate, whichever is greater.
- D. Provide concrete coverage in accordance with ACI 318.
- E. Set wire ties with ends directed into concrete, not toward exposed concrete surfaces.
- F. Splices: Lap splices as indicated on Drawings.
 - 1. Stagger splices in accordance with ACI 318.
- G. Install welded-wire reinforcement in longest practicable lengths.
 - 1. Support welded-wire reinforcement in accordance with CRSI "Manual of Standard Practice."
 - a. For reinforcement less than W4.0 or D4.0, continuous support spacing shall not exceed 12 inches.
 - 2. Lap edges and ends of adjoining sheets at least one wire spacing plus 2 inches for plain wire and 8 inches for deformed wire.
 - 3. Offset laps of adjoining sheet widths to prevent continuous laps in either direction.
 - 4. Lace overlaps with wire.

3.3 JOINTS

- A. Construction Joints: Install so strength and appearance of concrete are not impaired, at locations indicated or as approved by Architect.
 - 1. Place joints perpendicular to main reinforcement.
 - 2. Continue reinforcement across construction joints unless otherwise indicated.

3.4 INSTALLATION TOLERANCES

- A. Comply with ACI 117.

3.5 FIELD QUALITY CONTROL

- A. Special Inspections: Owner will engage a special inspector and qualified testing and inspecting agency to perform field tests and inspections and prepare test reports.
- B. Testing Agency: Engage a qualified testing and inspecting agency to perform tests and inspections and to submit reports.
- C. Inspections:
 - 1. Steel-reinforcement placement.

END OF SECTION 032000

SECTION 03 30 00 - CAST-IN-PLACE CONCRETE

PART 1 - GENERAL

1.1 SUMMARY

A. Section Includes:

1. Cast-in-place concrete, including concrete materials, mixture design, placement procedures, and finishes.

B. Related Requirements:

1. Section 031000 "Concrete Forming and Accessories" for form-facing materials.
2. Section 032000 "Concrete Reinforcing" for steel reinforcing bars and welded-wire reinforcement.

1.2 DEFINITIONS

- A. Cementitious Materials: Portland cement alone or in combination with one or more of the following: fly ash and other pozzolans materials subject to compliance with requirements.

- B. Water/Cement Ratio (w/cm): The ratio by weight of water to cementitious materials.

1.3 PREINSTALLATION MEETINGS

- A. Preinstallation Conference: Conduct conference at Project site.

1.4 ACTION SUBMITTALS

- A. Product Data: For each of the following.

1. Portland cement.
2. Fly ash.
3. Aggregates.
4. Admixtures:
 - a. Include limitations of use, including restrictions on cementitious materials, supplementary cementitious materials, air entrainment, aggregates, temperature at time of concrete placement, relative humidity at time of concrete placement, curing conditions, and use of other admixtures.
5. Vapor retarders.
6. Curing materials.
7. Joint fillers.

- B. Design Mixtures: For each concrete mixture, include the following:
1. Mixture identification.
 2. Minimum 28-day compressive strength.
 3. Durability exposure class.
 4. Maximum w/cm.
 5. Calculated equilibrium unit weight, for lightweight concrete.
 6. Slump limit.
 7. Air content.
 8. Nominal maximum aggregate size.
 9. Indicate amounts of mixing water to be withheld for later addition at Project site if permitted.
 10. Intended placement method.
 11. Submit alternate design mixtures when characteristics of materials, Project conditions, weather, test results, or other circumstances warrant adjustments.
- C. Shop Drawings:
1. Construction Joint Layout: Indicate proposed construction joints required to construct the structure.
 - a. Location of construction joints is subject to approval of the Architect.
- D. Concrete Schedule: For each location of each Class of concrete indicated in "Concrete Mixtures" Article, including the following:
1. Concrete Class designation.
 2. Location within Project.
 3. Exposure Class designation.
 4. Formed Surface Finish designation and final finish.
 5. Final finish for floors.
 6. Curing process.
 7. Floor treatment if any.

1.5 INFORMATIONAL SUBMITTALS

- A. Material Certificates: For each of the following, signed by manufacturers:
1. Cementitious materials.
 2. Admixtures.
 3. Curing compounds.
 4. Vapor retarders.
 5. Joint-filler strips.
- B. Material Test Reports: For the following, from a qualified testing agency:
1. Portland cement.
 2. Fly ash.
 3. Aggregates.
 4. Admixtures:

- C. Research Reports: For concrete admixtures in accordance with ICC's Acceptance Criteria AC198.
- D. Preconstruction Test Reports: For each mix design.
- E. Field quality-control reports.
- F. Minutes of preinstallation conference.

1.6 QUALITY ASSURANCE

- A. Ready-Mixed Concrete Manufacturer Qualifications: A firm experienced in manufacturing ready-mixed concrete products and that complies with ASTM C94/C94M requirements for production facilities and equipment.

1.7 PRECONSTRUCTION TESTING

- A. Preconstruction Testing Service: Engage a qualified testing agency to perform preconstruction testing on each concrete mixture.
 - 1. Include the following information in each test report:
 - a. Admixture dosage rates.
 - b. Slump.
 - c. Air content.
 - d. Seven-day compressive strength.
 - e. 28-day compressive strength.

1.8 DELIVERY, STORAGE, AND HANDLING

- A. Comply with ASTM C94/C94M and ACI 301.

1.9 FIELD CONDITIONS

- A. Cold-Weather Placement: Comply with ACI 301 and ACI 306.1.
- B. Hot-Weather Placement: Comply with ACI 301 and ACI 305.1.

PART 2 - PRODUCTS

2.1 CONCRETE, GENERAL

- A. ACI Publications: Comply with ACI 301 unless modified by requirements in the Contract Documents.

2.2 CONCRETE MATERIALS

A. Cementitious Materials:

1. Portland Cement: ASTM C150/C150M, Type I/II, gray.
2. Fly Ash: ASTM C618, Class C or F.

B. Normal-Weight Aggregates: ASTM C33/C33M, Class 3S coarse aggregate or better, graded. Provide aggregates from a single source.

1. Alkali-Silica Reaction: Comply with one of the following:
 - a. Expansion Result of Aggregate: Not more than 0.04 percent at one-year when tested in accordance with ASTM C1293.
 - b. Expansion Results of Aggregate and Cementitious Materials in Combination: Not more than 0.10 percent at an age of 16 days when tested in accordance with ASTM C1567.
 - c. Alkali Content in Concrete: Not more than 4 lb./cu. yd. for moderately reactive aggregate or 3 lb./cu. yd. for highly reactive aggregate, when tested in accordance with ASTM C1293 and categorized in accordance with ASTM C1778, based on alkali content being calculated in accordance with ACI 301.
2. Maximum Coarse-Aggregate Size: As indicated in General Structural Notes.
3. Fine Aggregate: Free of materials with deleterious reactivity to alkali in cement.

C. Lightweight Aggregate: ASTM C330/C330M, 3/4-inch nominal maximum aggregate size.

D. Air-Entraining Admixture: ASTM C260/C260M.

E. Chemical Admixtures: Certified by manufacturer to be compatible with other admixtures that do not contribute water-soluble chloride ions exceeding those permitted in hardened concrete. Do not use calcium chloride or admixtures containing calcium chloride.

1. Water-Reducing Admixture: ASTM C494/C494M, Type A.
2. Retarding Admixture: ASTM C494/C494M, Type B.
3. Water-Reducing and -Retarding Admixture: ASTM C494/C494M, Type D.
4. High-Range, Water-Reducing Admixture: ASTM C494/C494M, Type F.
5. High-Range, Water-Reducing and -Retarding Admixture: ASTM C494/C494M, Type G.
6. Plasticizing and Retarding Admixture: ASTM C1017/C1017M, Type II.

F. Water and Water Used to Make Ice: ASTM C94/C94M, potable [**or**] complying with ASTM C1602/C1602M, including all limits listed in Table 2 and the requirements of paragraph 5.4

2.3 VAPOR RETARDERS

A. Sheet Vapor Retarder, Class A: ASTM E1745, Class A; not less than 10 mils thick. Include manufacturer's recommended adhesive or pressure-sensitive tape.

2.4 CURING MATERIALS

- A. Absorptive Cover: AASHTO M 182, Class 2, burlap cloth made from jute or kenaf, weighing approximately 9 oz./sq. yd. when dry.
- B. Moisture-Retaining Cover: ASTM C171, polyethylene film burlap-polyethylene sheet.
 - 1. Color:
 - a. Ambient Temperature Below 50 deg F: Black.
 - b. Ambient Temperature between 50 deg F and 85 deg F: Any color.
 - c. Ambient Temperature Above 85 deg F: White.
- C. Curing Paper: Eight-foot-wide paper, consisting of two layers of fibered kraft paper laminated with double coating of asphalt.
- D. Water: Potable or complying with ASTM C1602/C1602M.
- E. Clear, Waterborne, Membrane-Forming, Dissipating Curing Compound: ASTM C309, Type 1, Class B.
 - 1. [<Double click here to find, evaluate, and insert list of manufacturers and products.>](#)

2.5 CONCRETE MIXTURES, GENERAL

- A. Prepare design mixtures for each type and strength of concrete, proportioned on the basis of laboratory trial mixture or field test data, or both, in accordance with ACI 301.
 - 1. Use a qualified testing agency for preparing and reporting proposed mixture designs, based on laboratory trial mixtures.
- B. Cementitious Materials: Limit percentage, by weight, of cementitious materials other than portland cement in concrete as follows:
 - 1. Fly Ash or Other Pozzolans: 25 percent by mass.
 - 2. Total of Fly Ash or Other Pozzolans: 35 percent by mass with fly ash or pozzolans not exceeding 25 percent by mass.
- C. Admixtures: Use admixtures in accordance with manufacturer's written instructions.
 - 1. Use water-reducing high-range water-reducing or plasticizing admixture in concrete, as required, for placement and workability.
 - 2. Use water-reducing and -retarding admixture when required by high temperatures, low humidity, or other adverse placement conditions.
 - 3. Use water-reducing admixture in pumped concrete, and concrete with a w/cm below 0.50.

2.6 CONCRETE MIXTURES

- A. See General Structural Notes.

2.7 CONCRETE MIXING

- A. Ready-Mixed Concrete: Measure, batch, mix, and deliver concrete in accordance with ASTM C94/C94M and ASTM C1116/C1116M, and furnish batch ticket information.

PART 3 - EXECUTION

3.1 INSTALLATION OF EMBEDDED ITEMS

- A. Place and secure anchorage devices and other embedded items required for adjoining Work that is attached to or supported by cast-in-place concrete.
 - 1. Use setting drawings, templates, diagrams, instructions, and directions furnished with items to be embedded.
 - 2. Install anchor rods, accurately located, to elevations required and complying with tolerances in Section 7.5 of ANSI/AISC 303.

3.2 INSTALLATION OF VAPOR RETARDER

- A. Sheet Vapor Retarders: Place, protect, and repair sheet vapor retarder in accordance with ASTM E1643 and manufacturer's written instructions.
 - 1. Install vapor retarder with longest dimension parallel with direction of concrete pour.
 - 2. Face laps away from exposed direction of concrete pour.
 - 3. Lap vapor retarder over footings and grade beams not less than 6 inches, sealing vapor retarder to concrete.
 - 4. Lap joints 6 inches and seal with manufacturer's recommended tape.
 - 5. Terminate vapor retarder at the top of floor slabs, grade beams, and pile caps, sealing entire perimeter to floor slabs, grade beams, foundation walls, or pile caps.
 - 6. Seal penetrations in accordance with vapor retarder manufacturer's instructions.
 - 7. Protect vapor retarder during placement of reinforcement and concrete.
 - a. Repair damaged areas by patching with vapor retarder material, overlapping damages area by 6 inches on all sides, and sealing to vapor retarder.

3.3 JOINTS

- A. Construct joints true to line, with faces perpendicular to surface plane of concrete.
- B. Construction Joints: Coordinate with floor slab pattern and concrete placement sequence.
 - 1. Install so strength and appearance of concrete are not impaired, at locations indicated on Drawings or as approved by Architect.
 - 2. Place joints perpendicular to main reinforcement.

- a. Continue reinforcement across construction joints unless otherwise indicated.
 - b. Do not continue reinforcement through sides of strip placements of floors and slabs.
3. Form keyed joints as indicated. Embed keys at least 1-1/2 inches into concrete.
 4. Locate joints at third points of spans.
- C. Control Joints in Slabs-on-Ground: Form weakened-plane control joints, sectioning concrete into areas as indicated. Construct control joints for a depth equal to at least one-fourth of concrete thickness as follows:
1. Grooved Joints: Form control joints after initial floating by grooving and finishing each edge of joint to a radius of 1/8 inch. Repeat grooving of control joints after applying surface finishes. Eliminate groover tool marks on concrete surfaces.
 2. Sawed Joints: Form control joints with power saws equipped with shatterproof abrasive or diamond-rimmed blades. Cut 1/8-inch-wide joints into concrete when cutting action does not tear, abrade, or otherwise damage surface and before concrete develops random cracks.

3.4 CONCRETE PLACEMENT

- A. Before placing concrete, verify that installation of formwork, reinforcement, embedded items, and vapor retarder is complete and that required inspections are completed.
1. Immediately prior to concrete placement, inspect vapor retarder for damage and deficient installation, and repair defective areas.
 2. Provide continuous inspection of vapor retarder during concrete placement and make necessary repairs to damaged areas as Work progresses.
- B. Notify Architect and testing and inspection agencies 24 hours prior to commencement of concrete placement.
- C. Do not add water to concrete during delivery, at Project site, or during placement unless approved by Architect in writing, but not to exceed the amount indicated on the concrete delivery ticket.
1. Do not add water to concrete after adding high-range water-reducing admixtures to mixture.
- D. Before test sampling and placing concrete, water may be added at Project site, subject to limitations of ACI 301, but not to exceed the amount indicated on the concrete delivery ticket.
1. Do not add water to concrete after adding high-range water-reducing admixtures to mixture.
- E. Deposit concrete continuously in one layer or in horizontal layers of such thickness that no new concrete is placed on concrete that has hardened enough to cause seams or planes of weakness.

1. If a section cannot be placed continuously, provide construction joints as indicated.
 2. Deposit concrete to avoid segregation.
 3. Deposit concrete in horizontal layers of depth not to exceed formwork design pressures and in a manner to avoid inclined construction joints.
 4. Consolidate placed concrete with mechanical vibrating equipment in accordance with ACI 301.
 - a. Do not use vibrators to transport concrete inside forms.
 - b. Insert and withdraw vibrators vertically at uniformly spaced locations to rapidly penetrate placed layer and at least 6 inches into preceding layer.
 - c. Do not insert vibrators into lower layers of concrete that have begun to lose plasticity.
 - d. At each insertion, limit duration of vibration to time necessary to consolidate concrete, and complete embedment of reinforcement and other embedded items without causing mixture constituents to segregate.
- F. Deposit and consolidate concrete for floors and slabs in a continuous operation, within limits of construction joints, until placement of a panel or section is complete.
1. Do not place concrete floors and slabs in a checkerboard sequence.
 2. Consolidate concrete during placement operations, so concrete is thoroughly worked around reinforcement and other embedded items and into corners.
 3. Maintain reinforcement in position on chairs during concrete placement.
 4. Screed slab surfaces with a straightedge and strike off to correct elevations.
 5. Level concrete, cut high areas, and fill low areas.
 6. Slope surfaces uniformly to drains where required.
 7. Begin initial floating using bull floats or darbies to form a uniform and open-textured surface plane, before excess bleedwater appears on the surface.
 8. Do not further disturb slab surfaces before starting finishing operations.

3.5 FINISHING FORMED SURFACES

A. As-Cast Surface Finishes:

1. ACI 301 Surface Finish SF-1.0: As-cast concrete texture imparted by form-facing material.
 - a. Patch voids larger than 1-1/2 inches wide or 1/2 inch deep.
 - b. Remove projections larger than 1 inch.
 - c. Tie holes do not require patching.
 - d. Surface Tolerance: ACI 117 Class D.
 - e. Apply to concrete surfaces [**not exposed to public view**] <Insert locations>.
2. ACI 301 Surface Finish SF-2.0: As-cast concrete texture imparted by form-facing material, arranged in an orderly and symmetrical manner with a minimum of seams.
 - a. Patch voids larger than 3/4 inch wide or 1/2 inch deep.
 - b. Remove projections larger than 1/4 inch.
 - c. Patch tie holes.

- d. Surface Tolerance: ACI 117 Class B.
- e. Locations: Apply to concrete surfaces exposed to public view, or to be covered with a coating or covering material applied directly to concrete.

B. Related Unformed Surfaces:

- 1. At unformed surfaces adjacent to formed surfaces, strike off smooth and finish with a color and texture matching adjacent formed surfaces.
- 2. Continue final surface treatment of formed surfaces uniformly across adjacent unformed surfaces unless otherwise indicated.

3.6 FINISHING FLOORS AND SLABS

A. Comply with ACI 302.1R recommendations for screeding, restraightening, and finishing operations for concrete surfaces. Do not wet concrete surfaces.

B. Scratch Finish:

- 1. While still plastic, texture concrete surface that has been screeded and bull-floated or darbied.
- 2. Use stiff brushes, brooms, or rakes to produce a profile depth of 1/4 inch in one direction.
- 3. Apply scratch finish to surfaces to receive concrete floor toppings.

C. Float Finish:

- 1. When bleedwater sheen has disappeared and concrete surface has stiffened sufficiently to permit operation of specific float apparatus, consolidate concrete surface with power-driven floats or by hand floating if area is small or inaccessible to power-driven floats.
- 2. Repeat float passes and restraightening until surface is left with a uniform, smooth, granular texture and complies with ACI 117 tolerances for conventional concrete.
- 3. Apply float finish to surfaces to receive trowel finish and to be covered with fluid-applied or sheet waterproofing, built-up or membrane roofing.

D. Trowel Finish:

- 1. After applying float finish, apply first troweling and consolidate concrete by hand or power-driven trowel.
- 2. Continue troweling passes and restraighten until surface is free of trowel marks and uniform in texture and appearance.
- 3. Grind smooth any surface defects that would telegraph through applied coatings or floor coverings.
- 4. Do not add water to concrete surface.
- 5. Do not apply hard-troweled finish to concrete, which has a total air content greater than 3 percent.
- 6. Apply a trowel finish to surfaces exposed to view or to be covered with resilient flooring, carpet, ceramic or quarry tile set over a cleavage membrane, paint, or another thin-film-finish coating system.

7. Finish and measure surface, so gap at any point between concrete surface and an unlevelled, freestanding, 10-ft.- long straightedge resting on two high spots and placed anywhere on the surface does not exceed 1/8 inch.
- E. Broom Finish: Apply a broom finish to exterior concrete platforms, steps, ramps, and locations indicated on Drawings.
1. Immediately after float finishing, slightly roughen trafficked surface by brooming with fiber-bristle broom perpendicular to main traffic route.
 2. Coordinate required final finish with Architect before application.

3.7 INSTALLATION OF MISCELLANEOUS CONCRETE ITEMS

A. Filling In:

1. Fill in holes and openings left in concrete structures after Work of other trades is in place unless otherwise indicated.
2. Mix, place, and cure concrete, as specified, to blend with in-place construction.
3. Provide other miscellaneous concrete filling indicated or required to complete the Work.

B. Curbs: Provide monolithic finish to interior curbs by stripping forms while concrete is still green and by steel-troweling surfaces to a hard, dense finish with corners, intersections, and terminations slightly rounded.

C. Equipment Bases and Foundations:

1. Coordinate sizes and locations of concrete bases with actual equipment provided.
2. Construct concrete bases as indicated unless otherwise indicated on Drawings, and extend base not less than 6 inches in each direction beyond the maximum dimensions of supported equipment unless otherwise indicated on Drawings, or unless required for seismic anchor support.
3. Minimum Compressive Strength: 4000 psi at 28 days.
4. Install dowel rods to connect concrete base to concrete floor. Unless otherwise indicated, install dowel rods on 18-inch centers around the full perimeter of concrete base.
5. For supported equipment, install epoxy-coated anchor bolts that extend through concrete base and anchor into structural concrete substrate.
6. Prior to pouring concrete, place and secure anchorage devices.
 - a. Use setting drawings, templates, diagrams, instructions, and directions furnished with items to be embedded.
 - b. Cast anchor-bolt insert into bases.
 - c. Install anchor bolts to elevations required for proper attachment to supported equipment.

3.8 CONCRETE CURING

- A. Protect freshly placed concrete from premature drying and excessive cold or hot temperatures.

1. Comply with ACI 301 and ACI 306.1 for cold weather protection during curing.
 2. Comply with ACI 301 and ACI 305.1 for hot-weather protection during curing.
 3. Maintain moisture loss no more than 0.2 lb/sq. ft. x h before and during finishing operations.
- B. Curing Formed Surfaces: Comply with ACI 308.1 as follows:
1. Cure formed concrete surfaces, including underside of beams, supported slabs, and other similar surfaces.
 2. Cure concrete containing color pigments in accordance with color pigment manufacturer's instructions.
 3. If forms remain during curing period, moist cure after loosening forms.
 4. If removing forms before end of curing period, continue curing for remainder of curing period, as follows:
 - a. Continuous Fogging: Maintain standing water on concrete surface until final setting of concrete.
 - b. Continuous Sprinkling: Maintain concrete surface continuously wet.
 - c. Absorptive Cover: Pre-dampen absorptive material before application; apply additional water to absorptive material to maintain concrete surface continuously wet.
 - d. Water-Retention Sheeting Materials: Cover exposed concrete surfaces with sheeting material, taping, or lapping seams.
 - e. Membrane-Forming Curing Compound: Apply uniformly in continuous operation by power spray or roller in accordance with manufacturer's written instructions.
 - 1) Recoat areas subject to heavy rainfall within three hours after initial application.
 - 2) Maintain continuity of coating and repair damage during curing period.
- C. Curing Unformed Surfaces: Comply with ACI 308.1 as follows:
1. Begin curing immediately after finishing concrete.
 2. Interior Concrete Floors:
 - a. Floors to Receive Floor Coverings Specified in Other Sections: Contractor has option of the following:
 - 1) Absorptive Cover: As soon as concrete has sufficient set to permit application without marring concrete surface, install prewetted absorptive cover over entire area of floor.
 - a) Lap edges and ends of absorptive cover not less than 12-inches.
 - b) Maintain absorptive cover water saturated, and in place, for duration of curing period, but not less than seven days.
 - 2) Moisture-Retaining-Cover Curing: Cover concrete surfaces with moisture-retaining cover for curing concrete, placed in widest

practicable width, with sides and ends lapped at least 12 inches, and sealed by waterproof tape or adhesive.

- a) Immediately repair any holes or tears during curing period, using cover material and waterproof tape.
 - b) Cure for not less than seven days.
- 3) Ponding or Continuous Sprinkling of Water: Maintain concrete surfaces continuously wet for not less than seven days, utilizing one, or a combination of, the following:
- a) Water.
 - b) Continuous water-fog spray.

b. Floors to Receive Curing Compound:

- 1) Apply uniformly in continuous operation by power spray or roller in accordance with manufacturer's written instructions.
- 2) Recoat areas subjected to heavy rainfall within three hours after initial application.
- 3) Maintain continuity of coating, and repair damage during curing period.
- 4) Removal: After curing period has elapsed, remove curing compound without damaging concrete surfaces by method recommended by curing compound manufacturer.

3.9 TOLERANCES

- A. Conform to ACI 117.

3.10 FIELD QUALITY CONTROL

- A. Special Inspections: Owner will engage a special inspector to perform field tests and inspections and prepare testing and inspection reports.
- B. Testing Agency: Owner will engage a qualified testing and inspecting agency to perform tests and inspections and to submit reports.
1. Testing agency shall be responsible for providing curing container for composite samples on Site and verifying that field-cured composite samples are cured in accordance with ASTM C31/C31M.
 2. Testing agency shall immediately report to Architect, Contractor, and concrete manufacturer any failure of Work to comply with Contract Documents.
 3. Testing agency shall report results of tests and inspections, in writing, to Owner, Architect, Contractor, and concrete manufacturer within 48 hours of inspections and tests.
 - a. Test reports shall include reporting requirements of ASTM C31/C31M, ASTM C39/C39M, and ACI 301, including the following as applicable to each test and inspection:

- 1) Project name.
 - 2) Name of testing agency.
 - 3) Names and certification numbers of field and laboratory technicians performing inspections and testing.
 - 4) Name of concrete manufacturer.
 - 5) Date and time of inspection, sampling, and field testing.
 - 6) Date and time of concrete placement.
 - 7) Location in Work of concrete represented by samples.
 - 8) Date and time sample was obtained.
 - 9) Truck and batch ticket numbers.
 - 10) Design compressive strength at 28 days.
 - 11) Concrete mixture designation, proportions, and materials.
 - 12) Field test results.
 - 13) Information on storage and curing of samples before testing, including curing method and maximum and minimum temperatures during initial curing period.
 - 14) Type of fracture and compressive break strengths at seven days and 28 days.
- C. Batch Tickets: For each load delivered, submit three copies of batch delivery ticket to testing agency, indicating quantity, mix identification, admixtures, design strength, aggregate size, design air content, design slump at time of batching, and amount of water that can be added at Project site.
- D. Inspections:
1. Headed bolts and studs.
 2. Verification of use of required design mixture.
 3. Concrete placement, including conveying and depositing.
 4. Curing procedures and maintenance of curing temperature.
 5. Verification of concrete strength before removal of shores and forms from beams and slabs.
 6. Batch Plant Inspections: On a random basis, as determined by Architect.
- E. Concrete Tests: Testing of composite samples of fresh concrete obtained in accordance with ASTM C 172/C 172M shall be performed in accordance with the following requirements:
1. Testing Frequency: Obtain one composite sample for each day's pour of each concrete mixture exceeding 5 cu. yd., but less than 25 cu. yd., plus one set for each additional 50 cu. yd. or fraction thereof.
 - a. When frequency of testing provides fewer than five compressive-strength tests for each concrete mixture, testing shall be conducted from at least five randomly selected batches or from each batch if fewer than five are used.
 2. Slump: ASTM C143/C143M:
 - a. One test at point of placement for each composite sample, but not less than one test for each day's pour of each concrete mixture.
 - b. Perform additional tests when concrete consistency appears to change.

3. Slump Flow: ASTM C1611/C1611M:
 - a. One test at point of placement for each composite sample, but not less than one test for each day's pour of each concrete mixture.
 - b. Perform additional tests when concrete consistency appears to change.
4. Air Content: ASTM C231/C231M pressure method, for normal-weight concrete; ASTM C173/C173M volumetric method, for structural lightweight concrete.
 - a. One test for each composite sample, but not less than one test for each day's pour of each concrete mixture.
5. Concrete Temperature: ASTM C1064/C1064M:
 - a. One test hourly when air temperature is 40 deg F and below or 80 deg F and above, and one test for each composite sample.
6. Unit Weight: ASTM C567/C567M fresh unit weight of structural lightweight concrete.
 - a. One test for each composite sample, but not less than one test for each day's pour of each concrete mixture.
7. Compression Test Specimens: ASTM C31/C31M:
 - a. Cast and laboratory cure two sets of two 6-inch by 12-inch or 4-inch by 8-inch cylinder specimens for each composite sample.
8. Compressive-Strength Tests: ASTM C39/C39M.
 - a. Test one set of two laboratory-cured specimens at seven days and one set of two specimens at 28 days.
 - b. A compressive-strength test shall be the average compressive strength from a set of two specimens obtained from same composite sample and tested at age indicated.
9. When strength of field-cured cylinders is less than 85 percent of companion laboratory-cured cylinders, Contractor shall evaluate operations and provide corrective procedures for protecting and curing in-place concrete.
10. Strength of each concrete mixture will be satisfactory if every average of any three consecutive compressive-strength tests equals or exceeds specified compressive strength, and no compressive-strength test value falls below specified compressive strength by more than 500 psi if specified compressive strength is 5000 psi, or no compressive strength test value is less than 10 percent of specified compressive strength if specified compressive strength is greater than 5000 psi.
11. Nondestructive Testing: Impact hammer, sonoscope, or other nondestructive device may be permitted by Architect but will not be used as sole basis for approval or rejection of concrete.
12. Additional Tests:
 - a. Testing and inspecting agency shall make additional tests of concrete when test results indicate that slump, air entrainment, compressive

strengths, or other requirements have not been met, as directed by Architect.

- b. Testing and inspecting agency may conduct tests to determine adequacy of concrete by cored cylinders complying with ASTM C42/C42M or by other methods as directed by Architect.

- 1) Acceptance criteria for concrete strength shall be in accordance with ACI 301 section 1.6.6.3.

- 13. Additional testing and inspecting, at Contractor's expense, will be performed to determine compliance of replaced or additional work with specified requirements.

- 14. Correct deficiencies in the Work that test reports and inspections indicate do not comply with the Contract Documents.

- F. Measure floor and slab flatness and levelness in accordance with ASTM E1155 within 24 hours of completion of floor finishing and promptly report test results to Architect.

3.11 PROTECTION

- A. Protect concrete surfaces as follows:

- 1. Protect from petroleum stains.
- 2. Diaper hydraulic equipment used over concrete surfaces.
- 3. Prohibit vehicles from interior concrete slabs.
- 4. Prohibit use of pipe-cutting machinery over concrete surfaces.
- 5. Prohibit placement of steel items on concrete surfaces.
- 6. Prohibit use of acids or acidic detergents over concrete surfaces.
- 7. Protect liquid floor treatment from damage and wear during the remainder of construction period. Use protective methods and materials, including temporary covering, recommended in writing by liquid floor treatments installer.
- 8. Protect concrete surfaces scheduled to receive surface hardener or polished concrete finish using Floor Slab Protective Covering.

END OF SECTION 033000

SECTION 03 53 00- CONCRETE TOPPING

PART 1 - GENERAL

1.1 SUMMARY

- A. Work Included: Provide and install concrete toppings (cementitious underlayments), complete, as shown on Drawings and as specified, including:
 - 1. Miscellaneous tapers and warps for alignment of top-of-finish flooring at transitions between materials of different heights and thickness, including:
 - a. Section 093000 – Tile.
 - b. Section 096519 – Resilient Tile Flooring.
 - c. Section 096813 – Tile Carpeting
 - d. Concrete Floors without finish or painted finish.
 - 2. Remedial correction of interior floor slabs to provide specified floor flatness as specified in Section 033000 – Cast-in-Place Concrete; at no additional cost to Owner.
- B. Work Specified Elsewhere:
 - 1. Section 033000 – Cast-in-Place Concrete. Use concrete from this Section when the thickness is at least 2-inches.
 - 2. Section 093000– Tile; Polymer-modified mortars for tile assemblies sloped to drains.

1.2 SUBMITTALS

- A. Comply with requirements of Section 013300 – Submittal Requirements.
- B. Product Data: Manufacturer's literature describing materials and specifications for mixing, placing, curing, and protecting.

1.3 QUALITY ASSURANCE

- A. Applicator: Approved and trained by manufacturer.
- B. Design Criteria:
 - 1. Compressive Strength: Minimum 4,100-PSI at 28 Days per ASTM C109.

1.4 PRODUCT HANDLING

- A. Delivery: Deliver and store packaged materials in original containers with seals unbroken and labels intact until time of use.

- B. Storage: Ensure storage facilities are weathertight and dry.

PART 2 - PRODUCTS

2.1 MANUFACTURERS

- A. General: Ardex Inc; Dependable Inc; or equal. Ardex products are specified as Basis-of-Design

2.2 MATERIALS

- A. Concrete Topping Types:

1. Self-Leveling Type for Interior Applications: Ardex K-15, or approved equal; 4,100-PSI compressive strength, 16-hour curing time. Installs from feather-edge depth to 1 1/2-inch depth without aggregate; installs up to 5-inch depth with addition of aggregate per manufacturer's written instructions.
2. Trowelable Fast-Setting Patch Type for Interior Applications: Ardex SD-P, or equal; 4,200-PSI compressive strength, 1-hour curing time. Installs from feather-edge depth to 1-inch depth without aggregate; installs up to 3-inch depth with addition of aggregate per manufacturer's written instructions.
3. Fast-Setting, Self-Leveling Type for Interior Applications: Ardex SD-T, or equal; 6,100-PSI compressive strength, 2-hour curing time. Installs from 1/4-inch to 2-inch depth without addition of aggregate, and up to 5-inches depth with addition of aggregate per manufacturer's written instructions.
4. Weather-Resistant, Self-Leveling Type for Interior Applications: Ardex A-300, 3,200-PSI compressive strength. Installs from 1/4-inch depth to 1/2-inch depth without aggregate; installs up to 3/4-inch depth with addition of aggregate per manufacturer's written instructions.
5. Polymer-Reinforced, Weather-Resistant Type for Interior Applications: Ardex Poly-Top, 5,500-PSI compressive strength. Installs from 1/4-inch depth to 1-inch depth without aggregate; installs up to 2-inch depth with addition of aggregate per manufacturer's written instructions.
6. Trowelable Fast-Setting Patch Type for Interior Applications: Ardex CD, 4,000-PSI compressive strength. Installs from 1/16-inch depth to 1/2-inch depth without aggregate.

- B. Primer: Ardex P-51, or equal, and as recommended in writing by the topping manufacturer for the substrata to receive topping.

- C. Aggregate:

1. Sand: 1/16-inch or less washed masonry sand, mortar sand, or plaster

sand.

2. Gravel: 3/8-inch pea gravel.

D. Water: Clean and potable, free from impurities detrimental to underlayment.

PART 3 - EXECUTION

3.1 EXAMINATION

A. Verification of Conditions: Examine substrate and verify that surfaces are free from debris and are reasonably clean and dry and that conditions are otherwise suitable to receive topping. Do not start Work until conditions are satisfactory.

3.2 PREPARATION

A. Cracks and Voids: Fill with trowelable fast-setting patch type concrete topping.

3.3 MIXES

A. General: Mix concrete toppings per manufacturer's recommendations.

B. Aggregates: Add sand or gravel aggregates to topping mix per manufacturer's recommendations for topping thickness.

3.4 INSTALLATION

A. General: Prime substrates, mix materials, and place toppings per manufacturer's recommendations.

B. Thickness: Install to thickness as shown or as required, spreading and screeding to smooth surface; abut level to existing surface.

C. Edge Forms: Provide as required.

D. Ramps and Slopes to Drains: Including other accommodations for level changes; form with trowelable fast-setting patch type cementitious underlayment.

1. Sloped-to-Drain Setting bed materials for Patient Bathrooms, Showers and Tub Rooms provided in 093000 – Tile.

E. Finish: As recommended by flooring manufacturer for reception of specified finish materials.

F. Exterior Work: Provide weather-resistant toppings at concealed locations or at the written direction of the Owner.

G. Transitions between Floor Finishes of differing thickness:

1. General: Provide concrete topping as required to align top-of-finish floor where flooring materials of different thickness meet.

2. Performance Criteria:
 - a. Provide concrete topping as required so that all offsets between adjacent floor materials are 1/8-inch or less.
 - b. Warp-applied concrete topping with a slope no greater than 1 inch in 48 inches, or a length of slope no less than 18 inches, whichever produces the more gentle transition.
3. Locations: Provide at locations where transitions between the following floor finishes occur that result in a vertical offset of greater than 1/8-inch:
 - a. Section 093000 – Tile.
 - b. Section 096519 – Resilient Flooring.
 - c. Section 096813 – Tile Carpeting.
 - d. Concrete Floors without finish or painted finish.

3.5 CURING

- A. General: Allow concrete topping to harden as recommended by manufacturer.
- B. Traffic: Do not permit traffic on topping during hardening period; minimum 2 hours or longer.
- C. Loading: Do not load floors until reasonable strength has been achieved. Evenly distribute any loading on topping and prohibit concentrated loading.
- D. Conditions: Maintain adequate ventilation and temperature above 50 degrees F. until topping is dry.

3.6 CLEANING AND REPAIR

- A. General: Repair concrete topping damaged after installation as a result of other trades prior to installation of scheduled floor finish, if any, at no additional cost to Owner.

END OF SECTION

SECTION 05 05 00 – METAL FASTENERS

PART 1 - GENERAL

1.1 SUMMARY

A. Work Included: This Section establishes general standards and requirements for metal fasteners utilized for attachment of items to the primary structure of the building and is incorporated in others Sections of these specifications where referenced, including:

1. Expansion Bolts.
2. Powder Actuated Devices.
3. Bolts, screws and other fasteners.

B. Work Specified Elsewhere:

1. Section 033000 – Cast-in-Place Concrete.
2. Section 092216 – Non-Structural Metal Framing
3. DIVISION 23 – Mechanical.
4. DIVISION 26 – Electrical.

1.2 SUBMITTALS

A. Comply with provisions of Section 013300 – Submittal Procedures.

B. Product Data: Manufacturers' information on materials, fabrication, and installation. Include current ICBO Reports and other information to substantiate compliance with Contract Documents.

C. Substitutions: Include with requests for substitution of fastening device type, minimum embedment, length, load capacity for pull out and shear, and installation torque of fasteners and statement that fastening devices meet or exceed requirements specified in Contract Documents.

1.3 QUALITY ASSURANCE

A. Field Quality Control:

1. The Owner's Testing Lab will perform and report on tests and inspections as follows:
2. Expansion Bolts:
 - a. Test 50 percent of drilled-in anchorages to 2.0 times the allowable load specified with special inspection in tension.

- b. If any anchor fails testing, test all anchors of the same category installed that day until twenty consecutive anchors pass, then resume the initial testing frequency. Cost of this testing shall be borne by Contractor.

PART 2 - PRODUCTS

2.1 MATERIALS

- A. Expansion Bolts: Hilti, Inc.'s Kwik Bolt II, Kwik Bolt III or equal; wedge type stud expansion anchor system, comply with FS FF-S-325, Group II, Type 4, Class 1. Provide stainless steel expansion bolts for exterior exposure.
- B. Powder Actuated Devices: Hilti Fastening Systems, Impex Tool Corporation, or equal; pins and tools. Tempered steel pins with special corrosion-resistant finish. Provide guide washers to accurately control penetration. Accomplish fastening by low-velocity piston-driven powder-actuated tool.
 1. Type and Size: Hilti X-DNI, dome head nail with smooth shank, 0.145-inch shank diameter, not less than 1-1/4-inch penetration.
- C. Sheet Metal Screws: John Wagner Associates' Grabber or equal: Unless otherwise noted on Drawings, type to suit stud, track, or channel gauge and as follows.
 1. Where Overlaid with Gypsum Board or Other Finish Material:
 - a. For Fastening to 20 Gauge and Lighter Material: No. 8 by 9/16-inch Wafer Head Streaker.
 - b. For Fastening to 18 Gauge and Heavier Material: No. 8 by 1/2-inch Wafer Head Self-Drilling.
 2. Where Not Overlaid with Finish Material:
 - a. For Fastening to 20 Gauge and Lighter Material: No. 8 by 9/16-inch Hex Head Streaker.
 - b. For Fastening to 18 Gauge and Heavier Material: No. 8 by 1/2-inch Hex Head Self-Drilling.
- D. Nuts and Bolts: ASTM A307 with suitable nuts, in accordance with ASTM A563, and washers 1/4-inch diameter, unless otherwise noted.
- E. U-Bolts: Special sizes and shapes shown; material as specified for nuts and bolts.

PART 3 - EXECUTION

3.1 INSTALLATION

- A. Expansion Bolts: Install in predrilled holes for fastening items into concrete.
1. Install expansion bolts according to the manufacturer's instructions as to tools, torque and tightening procedure.
 2. Expansion bolt locations and spacings: As shown.
 3. Edge Distance: Not less than 10 bolt diameters.
 4. Unless otherwise noted, install expansion bolts with manufacturer's recommended minimum embedments. Embedment length is exclusive of thickness of floor coverings, grout pads or other overlays.
 5. Do not recess expansion bolts more than one-fourth of the nominal bolt diameter. Abandon overdrilled holes or partially fill with nonshrink grout and redrill when grout has set.
 6. Abandon holes if the axis of a drilled hole deviates more than 5 degrees from normal to the concrete surface.
 7. If a concrete reinforcing bar is encountered during drilling, immediately terminate drilling and notify the Architect. Subject to review and approval the SEOR, the Architect may authorize using one of the following procedures:
 - a. If the location may be shifted, fill abandoned hole with non-shrink grout and install expansion bolt with a minimum of 1/2 inch of sound concrete between the expansion bolt and the abandoned hole, or...
 - b. If the location may not be shifted, use a diamond core drill to cut the rebar and drill the hole beyond the reinforcing such that the whole wedge portion of the expansion bolt can be expanded below the bar, or...
 - c. If the location may not be shifted, core an oversize hole at the direction of the Architect and grout an acceptable anchor in place.
- B. Fasten Work tightly to prevent rattle or vibration except where expansion-contraction tolerances are required.
- C. When expansion bolts are installed through metal deck into concrete slab above, embedment shall not extend closer than 3/4-inch to top of concrete. Locate at center of bottom flute. Minimum embedment shall be 1-1/2-inches above top flute of decking.

D. Expansion Bolt Test Values:

1. Test Procedure: Apply proof test loads by means of hydraulic ram, calibrating spring loading device, or torque wrench without removing nut if possible. If not possible, remove nut and install a threaded coupler to same tightness as original nut using a torque wrench.
2. Test Equipment: Calibrated by approved testing laboratory per standard industry procedures.
3. Expansion Bolts shall withstand following minimum test loads for specified wedge type anchors:

<u>Anchor Thread Size</u> (diameter in inches)	<u>Tension Test Load</u> (lbs.)	<u>Test Torque</u> ft-lbs.)
1/4	800	10
3/8	1100	25
1/2	2000	50
5/8	2300	80
3/4	3700	150
1	5800	250

4. Acceptance Criteria:
 - a. Hydraulic Ram Method: Expansion bolt is acceptable if there is no observable movement nor loosening of washer at application of tension test load.
 - b. Torque Wrench Method: Expansion bolt is acceptable if the test torque is reached within one-half turn of the nut.
5. Test Timing: Within 24 hours after expansion bolt installation and in the presence of the Inspector of Record.

END OF SECTION

SECTION 05 12 00 - STRUCTURAL STEEL FRAMING

PART 1 - GENERAL

1.1 RELATED DOCUMENTS

- A. Drawings and general provisions of the Contract, including General and Supplementary Conditions and Division 01 Specification Sections, apply to this Section.

1.2 SUMMARY

- A. Section Includes:
 - 1. Structural steel.
- B. Related Requirements:
 - 1. Section 055000 "Metal Fabrications" for other steel items not defined as structural steel.

1.3 DEFINITIONS

- A. Structural Steel: Elements of the structural frame indicated on Drawings and as described in ANSI/AISC 303.
- B. Seismic-Load-Resisting System: Elements of structural-steel frame designated as "SLRS".

1.4 PREINSTALLATION MEETINGS

- A. Preinstallation Conference: Conduct conference at Project site.

1.5 ACTION SUBMITTALS

- A. Product Data:
 - 1. Structural-steel materials.
 - 2. High-strength, bolt-nut-washer assemblies.
 - 3. Threaded rods.
 - 4. Shop primer.
 - 5. Galvanized repair paint.
- B. Shop Drawings: Show fabrication of structural-steel components.
 - 1. Include details of cuts, connections, splices, camber, holes, and other pertinent data.
 - 2. Indicate welds by standard AWS symbols, distinguishing between shop and field welds, and show size, length, and type of each weld. Show backing bars that

are to be removed and supplemental fillet welds where backing bars are to remain.

3. Indicate type, size, and length of bolts, distinguishing between shop and field bolts. Identify pretensioned and slip-critical, high-strength bolted connections.
 4. Identify members and connections of the seismic-load-resisting system.
 5. Identify members not to be shop primed.
- C. Welding Procedure Specifications (WPSs) and Procedure Qualification Records (PQRs): Provide in accordance with AWS D1.1/D1.1M for each welded joint whether prequalified or qualified by testing, including the following:
1. Power source (constant current or constant voltage).
 2. Electrode manufacturer and trade name, for demand-critical welds.

1.6 INFORMATIONAL SUBMITTALS

- A. Welding certificates.
- B. Mill test reports for structural-steel materials, including chemical and physical properties.
- C. Product Test Reports: For the following:
 1. Bolts, nuts, and washers, including mechanical properties and chemical analysis.
 2. Tension-control, high-strength, bolt-nut-washer assemblies.
- D. Source quality-control reports.
- E. Field quality-control reports.

1.7 QUALITY ASSURANCE

- A. Fabricator Qualifications: A qualified fabricator that participates in the AISC Quality Certification Program and is designated an AISC-Certified Plant, Category BU or is accredited by the IAS Fabricator Inspection Program for Structural Steel (Acceptance Criteria 172).
- B. Welding Qualifications: Qualify procedures and personnel in accordance with AWS D1.1/D1.1M.

1.8 DELIVERY, STORAGE, AND HANDLING

- A. Store materials to permit easy access for inspection and identification. Keep steel members off ground and spaced by using pallets, dunnage, or other supports and spacers. Protect steel members and packaged materials from corrosion and deterioration.
 1. Do not store materials on structure in a manner that might cause distortion, damage, or overload to members or supporting structures. Repair or replace damaged materials or structures as directed.

- B. Store fasteners in a protected place in sealed containers with manufacturer's labels intact.
 - 1. Fasteners may be repackaged provided Owner's testing and inspecting agency observes repackaging and seals containers.
 - 2. Clean and relubricate bolts and nuts that become dry or rusty before use.
 - 3. Comply with manufacturers' written recommendations for cleaning and lubricating ASTM F3125/F3125M, Grade F1852 bolt assemblies and for retesting bolt assemblies after lubrication.

PART 2 - PRODUCTS

2.1 STRUCTURAL-STEEL MATERIALS

- A. W-Shapes: ASTM A992/A992M.
- B. Channels, Angles: ASTM A36/A36M.
- C. Plate and Bar: ASTM A36/A36M.
- D. Cold-Formed Hollow Structural Sections: ASTM A500/A500M, Grade C structural tubing.
- E. Steel Pipe: ASTM A53/A53M, Type E or Type S, Grade B.
- F. Welding Electrodes: Comply with AWS requirements.

2.2 BOLTS AND CONNECTORS

- A. High-Strength A325 Bolts, Nuts, and Washers: ASTM F3125/F3125M, Grade A325, Type 1, heavy-hex steel structural bolts; ASTM A563, Grade DH, heavy-hex carbon-steel nuts; and ASTM F436/F436M, Type 1, hardened carbon-steel washers; all with plain finish.
- B. Tension-Control, High-Strength Bolt-Nut-Washer Assemblies: ASTM F3125/F3125M, Grade F1852, Type 1, heavy-hex or round head assemblies, consisting of steel structural bolts with splined ends; ASTM A563, Grade DH, heavy-hex carbon-steel nuts; and ASTM F436/F436M, Type 1, hardened carbon-steel washers.
 - 1. Finish: Plain.

2.3 RODS

- A. Threaded Rods: ASTM A36/A36M.
 - 1. Nuts: ASTM A63 heavy-hex carbon steel.
 - 2. Washers: ASTM F436, Type 1, hardened ASTM A36/A36M carbon steel.
 - 3. Finish: Hot-dip zinc coating, ASTM A153/A153M, Class C.

2.4 PRIMER

- A. Steel Primer:
 - 1. Fabricator's standard lead- and chromate-free, nonasphaltic, rust-inhibiting primer complying with MPI#79 and compatible with topcoat.

2.5 FABRICATION

- A. Structural Steel: Fabricate and assemble in shop to greatest extent possible. Fabricate in accordance with ANSI/AISC 303 and to ANSI/AISC 360.
 - 1. Camber structural-steel members where indicated.
 - 2. Fabricate beams with rolling camber up.
 - 3. Identify high-strength structural steel in accordance with ASTM A6/A6M and maintain markings until structural-steel framing has been erected.
 - 4. Mark and match-mark materials for field assembly.
 - 5. Complete structural-steel assemblies, including welding of units, before starting shop-priming operations.
- B. Thermal Cutting: Perform thermal cutting by machine to greatest extent possible.
 - 1. Plane thermally cut edges to be welded to comply with requirements in AWS D1.1/D1.1M.
- C. Bolt Holes: Cut, drill, or punch standard bolt holes perpendicular to metal surfaces.
- D. Finishing: Accurately finish ends of columns and other members transmitting bearing loads.
- E. Cleaning: Clean and prepare steel surfaces that are to remain unpainted in accordance with SSPC-SP 3.
- F. Holes: Provide holes required for securing other work to structural steel and for other work to pass through steel members.
 - 1. Cut, drill, or punch holes perpendicular to steel surfaces. Do not thermally cut bolt holes or enlarge holes by burning.

2.6 SHOP CONNECTIONS

- A. High-Strength Bolts: Shop install high-strength bolts in accordance with RCSC's "Specification for Structural Joints Using High-Strength Bolts" for type of bolt and type of joint specified.
 - 1. Joint Type: Snug tightened.
- B. Weld Connections: Comply with AWS D1.1/D1.1M and AWS D1.8/D1.8M for tolerances, appearances, welding procedure specifications, weld quality, and methods used in correcting welding work.
 - 1. Assemble and weld built-up sections by methods that maintain true alignment of axes without exceeding tolerances in ANSI/AISC 303 for mill material.

2.7 GALVANIZING

- A. Hot-Dip Galvanized Finish: Apply zinc coating by the hot-dip process to structural steel in accordance with ASTM A123/A123M.
 - 1. Fill vent and drain holes that are exposed in the finished Work unless they function as weep holes, by plugging with zinc solder and filing off smooth.
 - 2. Galvanize roof hatch.

2.8 SHOP PRIMING

- A. Shop prime steel surfaces, except the following:
 - 1. Surfaces embedded in concrete or mortar. Extend priming of partially embedded members to a depth of 2 inches.
 - 2. Surfaces to be field welded.
 - 3. Surfaces to receive sprayed fire-resistive materials (applied fireproofing).
 - 4. Galvanized surfaces.
 - 5. Surfaces enclosed in interior construction.
- B. Surface Preparation of Steel: Clean surfaces to be painted. Remove loose rust and mill scale and spatter, slag, or flux deposits. Prepare surfaces in accordance with the following specifications and standards:
 - 1. SSPC-SP 3.
- C. Surface Preparation of Galvanized Steel: Prepare galvanized-steel surfaces for shop priming by thoroughly cleaning steel of grease, dirt, oil, flux, and other foreign matter, and treating with etching cleaner or in accordance with SSPC-SP 16.
- D. Priming: Immediately after surface preparation, apply primer in accordance with manufacturer's written instructions and at rate recommended by SSPC to provide a minimum dry film thickness of 1.5 mils. Use priming methods that result in full coverage of joints, corners, edges, and exposed surfaces.
 - 1. Stripe paint corners, crevices, bolts, welds, and sharp edges.
 - 2. Apply two coats of shop paint to surfaces that are inaccessible after assembly or erection. Change color of second coat to distinguish it from first.

2.9 SOURCE QUALITY CONTROL

- A. Testing Agency: Owner will engage a qualified testing agency to perform shop tests and inspections.
 - 1. Allow testing agency access to places where structural-steel work is being fabricated or produced to perform tests and inspections.
 - 2. Bolted Connections: Inspect and test shop-bolted connections in accordance with RCSC's "Specification for Structural Joints Using High-Strength Bolts."
 - 3. Welded Connections: Visually inspect shop-welded connections in accordance with AWS D1.1/D1.1M and the following inspection procedures, at testing agency's option:
 - a. Liquid Penetrant Inspection: ASTM E165/E165M.

- b. Magnetic Particle Inspection: ASTM E709; performed on root pass and on finished weld. Cracks or zones of incomplete fusion or penetration are not accepted.
 - c. Ultrasonic Inspection: ASTM E164.
 - d. Radiographic Inspection: ASTM E94/E94M.
4. Prepare test and inspection reports.

PART 3 - EXECUTION

3.1 EXAMINATION

- A. Proceed with installation only after unsatisfactory conditions have been corrected.

3.2 PREPARATION

- A. Provide temporary shores, guys, braces, and other supports during erection to keep structural steel secure, plumb, and in alignment against temporary construction loads and loads equal in intensity to design loads. Remove temporary supports when permanent structural steel, connections, and bracing are in place unless otherwise indicated on Drawings.

3.3 ERECTION

- A. Set structural steel accurately in locations and to elevations indicated and in accordance with ANSI/AISC 303 and ANSI/AISC 360.
- B. Maintain erection tolerances of structural steel within ANSI/AISC 303.
- C. Align and adjust various members that form part of complete frame or structure before permanently fastening. Before assembly, clean bearing surfaces and other surfaces that are in permanent contact with members. Perform necessary adjustments to compensate for discrepancies in elevations and alignment.
 1. Level and plumb individual members of structure. Slope roof framing members to slopes indicated on Drawings.
 2. Make allowances for difference between temperature at time of erection and mean temperature when structure is completed and in service.
- D. Splice members only where indicated.
- E. Do not use thermal cutting during erection.
- F. Do not enlarge unfair holes in members by burning or using drift pins. Ream holes that must be enlarged to admit bolts.

3.4 FIELD CONNECTIONS

- A. High-Strength Bolts: Install high-strength bolts in accordance with RCSC's "Specification for Structural Joints Using High-Strength Bolts" for bolt and joint type specified.
 - 1. Joint Type: Snug tightened.
- B. Weld Connections: Comply with AWS D1.1/D1.1M and AWS D1.8/D1.8M for tolerances, appearances, welding procedure specifications, weld quality, and methods used in correcting welding work.
 - 1. Comply with ANSI/AISC 303 and ANSI/AISC 360 for bearing, alignment, adequacy of temporary connections, and removal of paint on surfaces adjacent to field welds.
 - 2. Assemble and weld built-up sections by methods that maintain true alignment of axes without exceeding tolerances in ANSI/AISC 303 for mill material.

3.5 REPAIR

- A. Galvanized Surfaces: Clean areas where galvanizing is damaged or missing, and repair galvanizing to comply with ASTM A780/A780M.
- B. Touchup Painting:
 - 1. Immediately after erection, clean exposed areas where primer is damaged or missing, and paint with the same material as used for shop painting to comply with SSPC-PA 1 for touching up shop-painted surfaces.

3.6 FIELD QUALITY CONTROL

- A. Special Inspections: Owner will engage a special inspector to perform the following special inspections:
 - 1. Verify structural-steel materials and inspect steel frame joint details.
 - 2. Verify weld materials and inspect welds.
 - 3. Verify connection materials and inspect high-strength bolted connections.
- B. Testing Agency: Owner will engage a qualified testing agency to perform tests and inspections.
 - 1. Bolted Connections: Inspect bolted connections in accordance with RCSC's "Specification for Structural Joints Using High-Strength Bolts."
 - 2. Welded Connections: Visually inspect field welds in accordance with AWS D1.1/D1.1M.
 - a. In addition to visual inspection, test and inspect field welds in accordance with AWS D1.1/D1.1M and the following inspection procedures, at testing agency's option:
 - 1) Liquid Penetrant Inspection: ASTM E165/E165M.

- 2) Magnetic Particle Inspection: ASTM E709; performed on root pass and on finished weld. Cracks or zones of incomplete fusion or penetration are not accepted.
- 3) Ultrasonic Inspection: ASTM E164.
- 4) Radiographic Inspection: ASTM E94/E94M.

END OF SECTION 051200

SECTION 05 50 10 – MISCELLANEOUS METAL FABRICATIONS**PART 1 - GENERAL****1.1 SUMMARY**

- A. Furnish labor, materials, tools, equipment, and services for Miscellaneous Metal Fabrications, as indicated, in accordance with provisions of Contract Documents.
- B. Completely coordinate with work of other trades.

1.2 QUALITY ASSURANCE

- A. ASTM International:
 - 1. ASTM A27 Standard Specification for Steel Castings, Carbon, for General Application
 - 2. ASTM A36 Standard Specification for Carbon Structural Steel
 - 3. ASTM A47 Standard Specification for Ferritic Malleable Iron Castings
 - 4. ASTM A48 Standard Specification for Gray Iron Castings
 - 5. ASTM A53 Standard Specification for Pipe, Steel, Black and Hot-Dipped, Zinc-Coated, Welded and Seamless
 - 6. ASTM A123 Standard Specification for Zinc (Hot-Dip Galvanized) Coatings on Iron and Steel Products
 - 7. ASTM A148 Standard Specification for Steel Castings, High Strength, for Structural Purposes
 - 8. ASTM A197 Standard Specification for Cupola Malleable Iron
 - 9. ASTM A276 Standard Specification for Stainless Steel Bars and Shapes
 - 10. ASTM A307 Standard Specification for Carbon Steel Bolts, Studs, and Threaded Rod 60 000 PSI Tensile Strength
 - 11. ASTM A325 Standard Specification for Structural Bolts, Steel, Heat Treated, 120/105 ksi Minimum Tensile Strength
 - 12. ASTM A354 Standard Specification for Quenched and Tempered Alloy Steel Bolts, Studs, and Other Externally Threaded Fasteners
 - 13. ASTM A480 Standard Specification for General Requirements for Flat-Rolled Stainless and Heat-Resisting Steel Plate, Sheet, and Strip
 - 14. ASTM A484 Standard Specification for General Requirements for Stainless Steel Bars, Billets, and Forgings
 - 15. ASTM A653 Standard Specification for Steel Sheet, Zinc-Coated (Galvanized) or Zinc-Iron Alloy-Coated (Galvannealed) by the Hot-Dip Process
 - 16. ASTM A666 Standard Specification for Annealed or Cold-Worked Austenitic Stainless Steel Sheet, Strip, Plate, and Flat Bar
 - 17. ASTM A668 Standard Specification for Steel Forgings, Carbon and Alloy, for General Industrial Use
 - 18. ASTM A992 Standard Specification for Structural Steel Shapes
 - 19. ASTM B26 Standard Specification for Aluminum-Alloy Sand Castings
 - 20. ASTM B209 Standard Specification for Aluminum and Aluminum-Alloy Sheet and Plate
 - 21. ASTM B221 Standard Specification for Aluminum and Aluminum-Alloy Extruded Bars, Rods, Wire, Profiles, and Tubes
 - 22. ASTM B308 Standard Specification for Aluminum-Alloy 6061-T6 Standard Structural Profiles
- B. American Society of Mechanical Engineers (ASME):

1. ANSI/ASME-A17.1 Handbook on Safety Code for Elevators and Escalators
- C. American Institute of Steel Construction (AISC)
 1. Steel Construction Manual
- D. American Iron and Steel Institute (AISI):
 1. Specification for the Design of Cold-Formed Steel Structural Members.
- E. American Welding Society (AWS):
 1. ANSI/AWS C1.1M/C1.1 Recommended Practices for Resistance Welding
 2. ANSI/AWS D1.1 Structural Welding Code - Steel.
 3. ANSI/AWS D1.3 Structural Welding Code - Sheet Steel.
- F. National Association of Architectural Metals Manufacturers (NAAMM):
 1. Class 1, Architectural, per NAAMM AMP-555, Code of Standard Practice for the Architectural Industry.

1.3 SUBMITTALS

- A. Shop Drawings:
 1. Plans and elevations showing members and connections.
 2. Anchors and accessory items.

PART 2 - PRODUCTS

2.1 ACCEPTABLE MANUFACTURERS

- A. Materials Listed:
 1. Base: As noted.
- B. Galvanizing Repair Paint:
 1. Base:
 - a. Tnemec.
 2. Optional:
 - a. ZRC Worldwide.
 - b. Sherwin-Williams.
- C. Shop Primer:
 1. Base:
 - a. As recommended by finish coat manufacturer for substrate.
 2. Optional:
 - a. Sherwin-Williams.
 - b. Tnemec.
- D. Non-shrink Grout:
 1. Base:
 - a. Dayton Superior Corporation.
 2. Optional:
 - a. Sauereisen.
 - b. CGM Building Products.
- E. Decorative Bollard Covers:
 1. Base:
 - a. Innoplast
- F. Other manufacturers desiring approval comply with Section 00 26 00.

2.2 MATERIALS

- A. Structural Steel:
 - 1. Steel, Structural W shapes and tee's: ASTM A992, 50KSI yield point.
 - 2. Other steel shapes and plate: ASTM A36.
 - 3. Pipe – Round ASTM A53 Grade B.
 - 4. Tubing square or rectangular: ASTM A500, grade-B, 46KSI minimum.
- B. Cast Steel:
 - 1. ASTM A27, Grade-65-35; and ASTM A148, Grade-80-50.
- C. Steel Forgings:
 - 1. ASTM A668.
- D. Bolts:
 - 1. ASTM A307, ASTM A325, ASTM A354.
- E. Filler Metal:
 - 1. AWS Standards.
- F. Cast Iron:
 - 1. ASTM A48, Class 30, minimum 30,000 PSI tensile.
- G. Malleable Iron:
 - 1. ASTM A47 and ASTM A197.
- H. Aluminum:
 - 1. ASTM B308 for particular alloy in standard shapes and extrusions.
 - 2. ASTM B26 for castings.
- I. Stainless Steel:
 - 1. ASTM A484 and ASTM A276.
 - 2. Concealed: Type 302 or Type 304.
 - 3. Exposed: Type 304.
 - a. Finish: ASTM A480 AISI finish #4, unless otherwise indicated.
 - 4. Exposed: Type 316.
 - a. Finish: ASTM A480 AISI finish #4, unless otherwise indicated.
- J. Masonry Anchorage Devices:
 - 1. Standard manufactured items.
 - 2. Lead expansion shields for machine screws and bolts 1/4 IN and smaller: Head out embedded nut type.
 - 3. For machine screws and bolts larger than 1/4 IN: Manufacturers' standard.
 - 4. Bolt anchor expansion shields for lag bolts: Zinc alloy, long shield anchors.
 - 5. Bolt anchor expansion shields for bolts: Closed end bottom bearing type.
 - 6. Anchor to embed or set device in setting compound or epoxy grout where shown.
- K. Fasteners:
 - 1. Galvanized or stainless where built into exterior walls.
 - 2. Select fasteners for type, grade and class required.
 - 3. Bolts and Nuts: Regular hexagon head ASTM A307, Grade-A.
 - 4. Lag Bolts: Square or octagonal head type.
 - 5. Machine Screws: Cadmium plated steel.
 - 6. Wood Screws: Flat head carbon steel.
 - 7. Plain Washers: Round, carbon steel.
 - 8. Lock Washers: Helical spring carbon steel.
- L. Non-shrink Grout:

1. Compressive strength: 9000 PSI at 7 days.
 2. Base Product: 1107 Advantage Grout by Dayton Superior.
- M. Abrasive Warning Tape:
1. Self-adhering, tape with slip resistive mineral surface.
 2. Color: Safety Yellow.
 3. Width: 2 IN, except where noted otherwise.
 4. Tape Type 2:
 - a. Base Product: Safety-Walk 530 Conformable by 3M.
 - b. Backing: Aluminum foil.
 - c. Thickness: 0.035 IN.
 - d. Use Type 2 at top and bottom rungs of ladders.

2.3 FABRICATION

- A. Form to shapes indicated with straight lines, sharp angles, and smooth curves.
- B. Shop fabricate in as large assemblies as practicable.
- C. Anchorage Accessories:
 1. Items required securing wood to metal, wood to masonry, metals to masonry or concrete, metal to metal or metal to other items.
- D. Drill or punch holes with smooth edges for temporary field connections and attachment of work by other trades.
 1. Conceal fastenings where practicable.
- E. Make permanent shop and field connections with continuous fillet type welds.
 1. Grind exposed welds smooth.
- F. Supply items required to complete construction and installation.
- G. Meet requirements specified under Structural Steel for fabricating items of structural nature or use.

2.4 FINISHES

- A. Items not to receive coatings:
 1. Surfaces scheduled to be fireproofed with spray-on material.
 2. Machined surfaces.
 3. Surfaces adjacent to field welds.
 4. Contact surfaces of bolt connections at slip connections.
 5. Top flanges of beams to receive shear connectors.
 6. Items for which no coating or field finish is specified.
- B. Shop Primer for Interior Non-wet Items:
 1. Primer: Coordinate with field applied finish systems specified in Section 09 91 23.
 2. Apply primer for interior finish paint to following surfaces not receiving other coating:
 - a. Surfaces exposed on interior.
 3. Clean thoroughly before priming; remove mill scale, rust, dirt, oil, and grease in accordance with SSPC-SP3.
 4. Apply in accordance with paint manufacturer's instructions.
 - a. Apply minimum 0.002 IN, dry film thickness.
- C. Hot-dip Galvanized (HDG) Coating for Exterior Items:
 1. Galvanize (HDG) the following items:
 - a. Items to be installed on site, roof or other areas that are outside of building enclosure walls. This shall include items attached to exterior walls of building.

- b. Items to be installed in wet or humid (>70 percent RH) areas of building.
 - c. Partial listing of items to receive HDG:
 - 1) Masonry lintels, ledge angles and shelf angles.
 - 2) Pipe Bollards.
 - 3) Exterior Ladders, Stairs and railings.
 - 4) Exterior gratings and substructure.
 - 5) Similar items which are exposed to weather or built-in to Exterior walls.
 - 6) Other items indicated.
 2. Clean thoroughly before galvanizing.
 3. Galvanize in accordance with ASTM A123.
- D. Galvanizing Repair Coating:
1. Tnemec Series 94-H20 Hydro-Zinc.
 2. ZRC Worldwide, Galvilite 221.
 3. Sherwin Williams Zinc Clad III HS 100.
 4. Galvanizing repair coating shall have a VOC content no greater than 250 g/L.
- E. Finish Painting:
1. Exterior: See Section 09 91 13.
 2. Interior: See Section 09 91 23.

2.5 METAL FABRICATIONS

- A. Ladders:
1. Design to comply with the following regulations:
 - a. ANSI-A14.3.
 - b. OSHA 29 1910.27.
 2. Material:
 - a. Exterior Ladders: Galvanized steel, painted by Section 09 91 13.
 - b. Interior Ladders: Shop-primed steel, painted by Section 09 91 23.
 3. Side rail members: Minimum 1/2 x 2 IN.
 4. Rungs: Minimum 3/4 IN round or square bars.
 5. Punch rungs through side rails and weld.
 6. Size to support concentrated moving load of 200 LB.
 7. Minimum clearance from centerline of rung to wall or obstruction: 7 IN.
 8. Minimum ladder width: 16 IN between side rails.
 9. Rung spacing: 12 IN O.C.
 10. Apply abrasive warning tape Type 2 to top and bottom rung of ladders.
 11. Elevator pit ladders:
 - a. Comply with general items above, except as amended by following:
 - b. Extend from bottom of pit to 4 FT above floor level.
 - c. Rungs: Minimum 3/4 IN round or square bars.
 - d. Rung clearance: 7 IN from center of rung to face of pit wall.
 - e. Maximum projection from wall: 8 IN or as directed by locally adopted codes and elevator running clearances.
 - f. Comply with ANSI/ASME-A17.1.
 - g. Coordinate final dimensions and locations with Elevator contractor.
- B. Metal Gratings:
1. Complying with NAAMM Metal Bar Grating Manual.
 2. Material and thickness (except where otherwise indicated):
 - a. Galvanized steel, nominal 1-1/2 IN thick.
 3. Load capacity: Support minimum uniform load of 200 PSF.
 4. Provide hold down clips.
 5. Furnish with frames and support items of comparable material and finish.

- C. Steel Support Angles, Support Frames, and Loose Lintel Steel Members:
 - 1. ASTM A36 steel, Sizes and configurations as indicated.
 - 2. Items to be hot dip galvanized:
 - a. Items to be permanently exposed to weather, high-humidity, or wet conditions.
 - b. Items set into exterior walls.
 - 3. Shop Prime interior items (in non-wet areas).
- D. Miscellaneous Equipment Supports:
 - 1. ASTM A36 steel, Sizes and configurations as indicated.
 - 2. Examples of items included:
 - a. Supports for Folding Partitions, Operable Walls, Coiling Doors and Grilles.
 - b. Supports for ICU Doors.
 - c. Support of Medical Equipment including Surgical Lights, Power Columns. And other items indicated.
 - d. Ceiling hung toilet partitions.
 - e. Other miscellaneous support items as indicated.
 - 3. Items to be hot dipped galvanized:
 - a. Items to be permanently exposed to weather, high-humidity, or wet conditions.
 - b. Items set into exterior walls.
 - 4. Shop Prime interior items (in non-wet areas).
- E. Bollards:
 - 1. Provide where indicated.
 - 2. Supply items required to complete construction and installation.
 - 3. Minimum Workmanship Standards (unless noted otherwise): Class 1, Architectural, per NAAMM AMP-555, Code of Standard Practice for the Architectural Industry.
 - 4. Utility Bollards Type UB-1:
 - a. 6 IN diameter extra strength, HDG (galvanized), steel pipe.
 - b. Length: Unless otherwise indicated; minimum 42 IN projection above ground and 36 IN embedment into concrete.
 - c. Fabricate with welded on anchors.
 - d. Fill pipe with 3000 PSI concrete with rounded top.
 - e. Paint (in-field) by Division 09.
 - 5. Steel Bollards with Decorative Cover Type DB-1:
 - a. Assembly including a concrete-filled steel pipe with a decorative cover sleeve.
 - b. Steel pipe bollard:
 - 1) 6 IN diameter extra strength, hot dip galvanized steel pipe.
 - 2) Length: Unless otherwise indicated; minimum 42 IN projection above ground and 36 IN embedment into concrete.
 - 3) Fabricate with welded on anchors.
 - 4) Fill with 3000 PSI concrete, flush at top.
 - c. Decorative Bollard Covers:
 - 1) Description: 1/8 IN thick, HDPE.
 - 2) Size as appropriate for pipe.
 - 3) Color: To be selected by Architect.
 - a) Five year warranty for color-fastness, cracking and UV-resistance.
 - 4) Dual reflective stripes near top of cover.
 - 5) Base Product: Bollardgard by Innoplast.
- F. Slip-resistant Stair Nosings:
 - 1. For use on exterior concrete steps.
 - 2. Abrasive type with steel wing anchors and recessed screws to allow replacement of units:
 - 3. Space anchors not over 24 IN on center.

4. Minimum 3 anchors per nosing.
 5. Furnish units full width of treads.
 6. Base Product: XH 300 (modified) by Balco Inc.
 7. Optional:
 - a. Amstep Products/Div American Safety Tech.
 - b. Wooster Products; WP3T.
- G. Diamond plate wall protection at Material Management, where indicated:
1. 1/4 IN thick checker plate.

2.6 GAS AND LIQUID CYLINDER RESTRAINT ASSEMBLY

- A. Cylinder Rack Assembly (Steel Tube Assembly):
1. Acceptable Manufacturers:
 - a. Safe-T-Rack Systems, Inc.
 - b. Spectra Gases, Inc.
 - c. Matheson Tri-Gas.
 - d. Air Liquide.
 - e. Other manufacturers desiring approval comply with Section 00 26 00.
 - f. Substitutions are not permitted.
 2. Frame members: 50mm 2 IN x 50mm 2 IN x 3mm 1/8 IN square steel tube.
 3. Construction:
 - a. All welded construction.
 - b. Weld cover plates to close exposed tube ends.
 - c. Grind and polish welds to produce smooth surface with no visible evidence of welding when painted.
 - d. Frame shall have welded chain link or similar hardware for attachment for each end of chain.
 - e. Finish:
 - 1) Powder coated factory finish.
 - 2) Color shall be selected by Architect.
 4. Retainer Rods:
 - a. Provide 6mm 1/4 IN diameter stainless steel retainer rods with turned down ends.
 - b. Drill 7mm 9/32 IN diameter holes in top rails to receive retaining rods.
 5. Chain and Associated Hardware:
 - a. Chain and hardware shall be Type 304 or Type 316 stainless steel.
 - b. Chain: 6mm 1/4 IN diameter, welded chain. Two chains per cylinder at high and low points.
 - c. Provide threaded connector chain link at each end and one harness clip at the one end: McMaster-Carr Supply Company, Suncor Stainless, Inc. Other manufacturers desiring approval comply with Section 00 26 00.

PART 3 - EXECUTION

3.1 INSPECTION

- A. Verify suitability of substrate to accept installation.
- B. Installation constitutes acceptance of responsibility for performance.
- C. Verify wall backing has been installed for wall-mounted items specified in this Section.
 1. See Section 09 22 16.

3.2 INSTALLATION

A. General:

1. Set work level, true to line, plumb.
2. Weld field connections and grind smooth.
3. Where practical, conceal fastenings.
4. Secure metal to wood with lag screws of adequate size with appropriate washers.
5. Secure metal to concrete with embedded anchors, setting compounds, caulking and sleeves, or setting grout.
 - a. Use expansion bolts, toggle bolts, or screws for light duty service.
6. Meet structural requirements for erecting items of structural nature.
7. Do not field splice fabricated items unless size requires splicing.
8. Weld splices.
9. Provide fabricated items complete with attachment devices as required to install.

B. Galvanic Repair:

1. After galvanized units have been erected and anchored apply galvanizing repair paint in accordance with manufacturer's recommendations.
2. Surface preparation: Remove contaminates in accordance with SSPC SP-1.

C. Bollards:

1. Direct-buried:
 - a. Hole Depth: 6 IN deeper than embedment length specified for bollard.
 - b. Hole Diameter: 24 IN diameter for 6 IN diameter pipes.
 - c. Set pipe bollards plumb and to the exposure height indicated.
2. Surface-Bolted and other means of attachment: Install as detailed.
3. Fill annular space with concrete fill having a compressive strength of at least 3000 PSI.
4. Paint or cover with decorative sleeves as scheduled.

END OF SECTION 05 50 10

SECTION 06 10 00- ROUGH CARPENTRY

PART 1 - GENERAL

1.1 SUMMARY

- A. Work Included: Rough carpentry, complete, as shown on Drawings and as specified, including:
 - 1. Miscellaneous fire-treated blocking, backing and plywood as shown.
- B. Work Specified Elsewhere:
 - 1. Section 064123 – Interior Architectural Woodwork.

1.2 REFERENCE STANDARDS

- A. American Plywood Association (APA):
 - 1. Guide to Plywood Grades.
- B. American Wood Preservers Association (AWPA):
 - 1. C20; Structural Lumber - Fire-Retardant Treatment by Pressure Process.
 - 2. C27; Plywood - Fire-Retardant Treatment by Pressure Process.
 - 3. M4; Standard for the Care of Preservative-Treated Wood Products.
- C. West Coast Lumber Inspection Bureau (WCLIB):
 - 1. Standard Grading Rules for West Coast lumber.
- D. Western Wood Products Association (WWPA):
 - 1. Western Lumber Grading Rules.

1.3 SUBMITTALS

- A. Comply with requirements of Section 013300 – Submittal Requirements.
- B. Shop Drawings: Show specially fabricated rough hardware.

1.4 QUALITY ASSURANCE

- B. Comply with latest edition of the following standards:
 - 1. Western Coast Lumber Inspection Bureau (WCLIB) "Standard Grading Rules No. 16."
 - 2. Western Wood Products Association (WWPA) "Grading Rules for Western

Lumber."

3. American Plywood Association (APA) "Guide to Plywood Grades."
 4. United States Product Standard (PS) "Construction and Industrial Plywood" (PS 1-74).
 5. American Wood Preserver's Association (AWPA):
 - a. "Structural Lumber - Fire-Retardant Treatment by Pressure Process" (AWPA C27-74).
 - b. "Plywood - Fire-Retardant Treatment by Pressure Process" (AWPA C27-74).
- C. Grade Marks: Identify all wood materials by official grade mark.
1. Lumber: Mark each piece of lumber with grade mark WCLIB (or WWPA) or of agency certified by WCLIB (or WWPA), and accompany each mill shipment to site by certificate of inspection by WCLIB (or WWPA) and FR-S where fire treatment is required.
 2. Softwood Plywood: Show Type, Grade, Class and Identification Index; per APA Guide to Plywood Grades, and per requirements of NBS PS-1.
- C. Fire-Retardant Treatment:
1. Fire-Retardant Treatment: UL classification FR-S.
 2. Obtain each type of fire-retardant treated wood products from one source for both treatment and fire-retardant formulation.
- D. Pressure treatment shall not adversely affect application, permanence, or appearance of finish paint systems.

1.5 PRODUCT HANDLING

- A. Facilities: Provide proper facilities for handling and storage of materials to prevent damage to edges, ends, and surfaces.
- B. Storage: Keep materials dry. Stack materials off ground on level flat forms, fully protected from weather.

1.6 PROJECT CONDITIONS

- A. Environmental Requirements: Maintain uniform moisture content of lumber at not more than 19 percent before, during and after installation.
- B. Sequencing and Scheduling: Coordinate details with other Work supporting, adjoining or fastening to rough carpentry Work.

PART 2 - PRODUCTS

ROUGH CARPENTRY

2.1 MATERIALS

A. Wood (all wood shall be fire treated):

1. Lumber: Douglas fir; No. 3 or construction grade per WCLIB.
2. Plywood: NBS PS-1 - grade structural one, C-C exterior.
3. Use only material that is free of urea-formaldehyde.

B. Fasteners:

1. Nails: Common wire typical.
2. Powder-Actuated Devices (PAD): As specified in Section 050500 – Metal Fasteners.
3. Expansion Bolts: As specified in Section 050500 – Metal Fasteners.
4. Miscellaneous Hardware: Provide common screws, bolts, fastenings, washers and nuts, and other items required to complete rough carpentry Work.
5. Finish: Hot-dip galvanize fasteners for exterior work.

2.2 ROUGH HARDWARE

A. All exterior hardware shall be hot-dipped galvanized per ASTM A-123 Standards.

1. Nails:

- a. Common wire for typical framing, blocking, etc. Box nails will not be allowed.
- b. Annular ring common wire nails for plywood floor.

2. Bolts: Hexagonal heads, Grade A conforming to ASTM A307.

3. Washers: Washers for bearing against wood shall be provided under all bolt heads and nuts.

- a. Malleable iron or steel plate having an area equal to 16 times the area of bolt or lag screw.
- b. Steel washers shall have a thickness not less than 1/10 the length of the washer's longest side.
- c. Malleable iron washers shall have a thickness not less than 1/2 the bolt or lag screw diameter and having a bearing surface for the nut or head equal in diameter to not less than the long diameter of the nut or head.

4. Anchor Bolts: Hexagonal heads, Grade A conforming to ASTM 307, 1-1/2-inch-diameter by 10 inch.
 5. Rough Framing Connectors: KC Metal Products or approved equal. For connector type, see Drawings.
- B. Powder Driven Fasteners, Expansion Bolts and Expansion Anchors: As specified under 050500 – Metal Fasteners.

2.3 FABRICATION

- A. Lumber:
1. Moisture Content: Air- or kiln-dry to 19 percent maximum moisture content at time of surfacing.
 2. Finish: Surfaced four sides, S4S, unless otherwise specified.
 3. Size: Per rules of governing standard. Sizes shown are nominal unless otherwise specified.
- B. Fire-Retardant Treated Lumber and Plywood: Pressure treat rough carpentry materials per Reference Standards to obtain specified UL Classification.
1. Type: Hoover Treated Wood Products, "Exterior Fire-X," or equal.

PART 3 - EXECUTION

3.1 EXAMINATION

- A. Verification of Conditions: Examine areas to receive rough carpentry Work and verify following:
1. Completion of installation of building components to receive rough carpentry Work.
 2. That spacing, direction, and details of supports are correct to accommodate installation of blocking, backing, stripping, furring, and nailers.
 3. That surfaces are satisfactory to receive Work. Do not commence installation until unsatisfactory conditions have been corrected.

3.2 INSTALLATION

- A. General: Provide wood blocking, backing, furring, grounds, nailers, stripping, and similar items as detailed and otherwise required to anchor fixtures and equipment to be installed by other trades. Perform cutting, boring, and similar Work required. Install members true to line. Fit accurately. Secure rigidly. Provide special framing, even if not specifically shown, as required to properly complete Work.
- B. Sills or Plates on Concrete: Set in grout if surface of concrete deviates from true

plane by more than 1/16-inch in 4 feet. Anchor with bolts as shown. Use two bolts minimum per piece with one bolt located between 4 inches and 8 inches from each end of each piece of sill.

- C. Nail Joints: Per minimum requirements of applicable code unless otherwise shown.
- D. Plywood: Sheet layout, nailing and edge-blocking as shown. Gap joints 1/16-inch. Butt joints accurately at centerlines of supporting members.
- E. Fasteners:
 - 1. General: Furnish and accurately locate items to be embedded in concrete. Secure such items in place before concrete is poured.
 - 2. Nails: If wood tends to split, pre-drill holes three-fourths of nail diameter.
 - 3. Lag Screws: Screw into place; do not hammer. Use soap or other lubricant to ease insertion. Pre-drill holes diameter of shank for unthreaded portion, two-thirds of shank diameter for threaded portion.
 - 4. Bolts and Nuts: When installed, bear no more than 1/2-inch of threads on wood and allow no more than 1/2-inch of bolt to project beyond nut. Drill bolt holes 1/32-inch oversize. Tighten nuts snug when placed, and re-tighten at end of job or just before closing in.
 - 5. Sheet Metal Fasteners: Nail or bolt per manufacturer's instructions. Nail or bolt holes. Use nails provided by manufacturer.

3.3 PLYWOOD BACKING FOR TELEPHONE AND ELECTRICAL EQUIPMENT

- A. Panels: Not less than 3/4-inch thick. Use largest sizes practicable.
- B. Joints: Tightly butt vee-joints.
- C. Finish: Slightly ease exposed edges, sandpaper smooth as required.
- D. Fastening: Secure to metal studs and backing plates with flat-head countersunk sheet metal screws at 12-inch centers at panel edges and at 16-inch centers in panel field.

END OF SECTION

SECTION 06 41 23- INTERIOR ARCHITECTURAL WOODWORK

PART 1 - GENERAL

1.1 RELATED DOCUMENTS

- A. Drawings and general provisions of the Contract, including General and Supplementary Conditions and Division 1 Specification Sections, apply to this Section.

1.2 SUMMARY

- A. Work Included: Provide and install Casework, complete, as shown on Drawings and as specified. All casework to be:

AWI Premium Grade Fabrications.

- B. This Section includes the following:

- 1. Plastic-laminate cabinets.
- 2. Plastic-laminate countertops.
- 3. Solid-surfacing-material countertops and integral sinks.

- C. Related Sections include the following:

- 1. Division 6 Section "Rough Carpentry" for wood furring, blocking, shims, and hanging strips required for installing woodwork and concealed within other construction before woodwork installation.
- 2. Division 8 Section "Flush Wood Doors."

1.3 DEFINITIONS

- A. Interior architectural woodwork includes wood furring, blocking, shims, and hanging strips for installing woodwork items, unless concealed within other construction before woodwork installation.

1.4 SUBMITTALS

- A. Shop Drawings: Show location of each item, dimensioned plans and elevations, large-scale details, attachment devices, and other components.

- B. Samples for Initial Selection: Manufacturer's color charts consisting of units or sections of units showing the full range of colors, textures, and patterns available for each type of material indicated.

- 1. Plastic laminates.
- 2. Shop-applied transparent finishes.

- C. Samples for Verification:

1. Plastic laminates, 8 by 10 inches, for each type, color, pattern, and surface finish.
2. Solid-surfacing materials, 6 inches square.
3. One sample door with required hardware.

1.5 QUALITY ASSURANCE

- A. Installer Qualifications: An experienced installer who has completed architectural woodwork similar in material, design, and extent to that indicated for this Project and whose work has resulted in construction with a record of successful in-service performance.
- B. Fabricator Qualifications:
 1. Shop that employs skilled workers who custom-fabricate products similar to those required for this Project and whose products have a record of successful in-service performance.
 2. Shop is a certified participant in AWI's Quality Certification
- C. Quality Standard: Unless otherwise indicated, comply with AWI's "Architectural Woodwork Quality Standards" for grades of interior architectural woodwork, construction, finishes, and other requirements.
 1. Provide AWI certification labels or compliance certificate indicating that woodwork complies with requirements of grades specified.
- D. Single-sourcing materials: It is the intent of the Contract Documents to single-source plastic laminate and solid surface materials specified in this section when scheduled on the drawings to assure matching of specified finishes.

1.6 DELIVERY, STORAGE, AND HANDLING

- A. Do not deliver woodwork until painting and similar operations that could damage woodwork have been completed in installation areas. If woodwork must be stored in other than installation areas, store only in areas where environmental conditions comply with requirements specified in "Project Conditions" Article.

1.7 PROJECT CONDITIONS

- A. Environmental Limitations: Do not deliver or install woodwork until building is enclosed, wet work is complete, and HVAC system is operating and maintaining temperature and relative humidity at occupancy levels during the remainder of the construction period.
- B. Field Measurements: Where woodwork is indicated to fit to other construction, verify dimensions of other construction by field measurements before fabrication and indicate measurements on Shop Drawings. Coordinate fabrication schedule with construction progress to avoid delaying the Work.
 1. Established Dimensions: Where field measurements cannot be made without delaying the Work, establish dimensions and proceed with fabricating woodwork without field measurements. Provide allowance for trimming at site, and coordinate construction to ensure that actual dimensions correspond to established dimensions.

1.8 COORDINATION

- A. Coordinate sizes and locations of framing, blocking, furring, reinforcements, and other related units of Work specified in other Sections to ensure that interior architectural woodwork can be supported and installed as indicated.

PART 2 - PRODUCTS

2.1 MATERIALS

- A. General: Provide materials that comply with requirements of the AWI quality standard for each type of woodwork and quality grade specified, unless otherwise indicated.
- B. Wood Species and Cut for Transparent Finish:
 - 1. Species: Maple (Acer Saccharum)
 - 2. Application:
 - a. Cut: Plan Sliced
 - b. Figure: All light colored wood
 - c. Face Panel Grade: HPVA Grade A
 - d. Color: Stain to match patient room cabinets on adjacent floors
- C. Wood Products: Comply with the following:
 - 1. Hardboard: AHA A135.4.
 - 2. Softwood Plywood: DOC PS 1, Medium Density Overlay.
 - 3. Hardwood Plywood and Face Veneers: HPVA HP-1.
- D. Thermoset Decorative Overlay: Particleboard complying with ANSI A208.1, Grade M-2, or medium-density fiberboard complying with ANSI A208.2, Grade MD, with surface of thermally fused, melamine-impregnated decorative paper complying with LMA SAT-
- E. High-Pressure Decorative Laminate: NEMA LD 3, grades as indicated, or if not indicated, as required by woodwork quality standard.
 - 1. Manufacturer: Subject to compliance with requirements, provide high-pressure decorative laminates by one of the following:
 - a. Lamin-Art
- F. Solid-Surfacing Material: Homogeneous solid sheets of filled plastic resin complying with ISSFA-2.
 - 1. Manufacturers: Subject to compliance with requirements, provide products by one of the following:
 - a. Solid Surface: Corian
 - 2. Type: Standard slab type, unless Special Purpose type is indicated.
 - 3. Colors and Patterns: as per finish schedule.

- G. Adhesive for Bonding Plastic Laminate: Contact cement.
- H. Edge-banding:
1. Edge-banding for cabinet body parts shall be purified **3 mm PVC** applied with hot melt glue by automatic edge-banding equipment.
 2. Edge-banding for door and drawer fronts shall be purified 3 mm PVC applied with hot melt glue by automatic edge-banding equipment. Edges and corners shall be rounded with a 3 mm radius and scraped free from machining or chatter marks.
 3. Color shall match vertical laminate at cabinets or as selected by Architect from manufacturer's full color range for solids and patterns.
- I. Cores:
1. All sides, tops, countertops, bottoms, doors, drawer fronts, and partitions shall have minimum $\frac{3}{4}$ " thick multi-core premium grade panel product cores manufactured for uses as a core material for laminated casework. Provide 1-inch thickness for bottom panel of wall hung units (same as shelves).
 2. Shelf Cores: Shelves shall have the same core material as specified for the cabinet body except provide 3/4-inch thickness.
 3. Multi-Core Panel Products:
 - Simpson Plyron, Simpson
 - States Industries "Armorcore"
 - True North "**Multi - Core**"

2.2 CABINET HARDWARE AND ACCESSORIES

- A. General: Provide cabinet hardware and accessory materials associated with architectural cabinets.
- B. Hardware Standard: Comply with BHMA A156.9 for items indicated by referencing BHMA numbers or items referenced to this standard.
- C. Frameless Concealed Hinges (European Type): BHMA A156.9, B01602, 170 degrees of opening, self-closing.
- D. Door and Drawer Pulls: Back mounted, 5 inches long, Bow Pull, Finish- Satin Nickel, 5/16" in diameter. Basis of Design: Liberty P0256A-SN-C1 (128mm Bow Pull/Satin Nickle)
- E. Catches: Magnetic catches, BHMA A156.9, B03141.
- F. Shelf Rests: BHMA A156.9, B04013.
- G. Drawer Slides: Side-mounted, full-extension, zinc-plated steel drawer slides with steel ball bearings, BHMA A156.9, B05091, and rated for the following loads:
1. Box Drawer Slides: 100 lbf.
 2. Pencil Drawer Slides: 45 lbf.
- H. Door Locks: BHMA A156.11, E07121. **(Typical at base cabinets at sink locations)**
- I. Drawer Locks: BHMA A156.11, E07041.

- J. Keyboard Trays: VersaTables, 24 inches wide, 14 inches deep, Model KD-2414
- K. Grommets for Cable Passage through Countertops: 2-1/2-inch beige, molded-plastic grommets and matching plastic caps with slot for wire passage.
- L. Exposed Hardware Finishes: For exposed hardware, provide finish that complies with BHMA A156.18 for BHMA finish number indicated.
 - 1. Satin Chromium Plated: BHMA 652 for steel base.
- M. For concealed hardware, provide manufacturer's standard finish that complies with product class requirements in BHMA A156.9.
- N. Keyless Security Locks: **(Typical at all P-Lam lockers)**
 - a. Keyless access
 - b. Four digit code
 - c. Power: Operates on two 1.5V AAA batteries
 - d. Operation: 15,000 openings
 - e. Low battery signal with battery failure override
 - f. Dimensions: 5-3/8 inches long by 1-1/4 inches wide by 1-3/16 inches deep to top of handle
 - g. Color: Selected by Architect
 - h. Public/private function
 - i. Base Product: Kit-Lock KL1000 by Codelocks Ltd.

2.3 INSTALLATION MATERIALS

- A. Furring, Blocking, Shims, and Hanging Strips: Softwood or hardwood lumber, kiln-dried to less than 15 percent moisture content.
- B. Anchors: Select material, type, size, and finish required for each substrate for secure anchorage. Provide nonferrous-metal or hot-dip galvanized anchors and inserts on inside face of exterior walls and elsewhere as required for corrosion resistance. Provide toothed-steel or lead expansion sleeves for drilled-in-place anchors.

2.4 FABRICATION, GENERAL

- A. Interior Woodwork Grade: Provide **Premium Grade** interior woodwork complying with the referenced quality standard.
- B. Wood Moisture Content: Comply with requirements of referenced quality standard for wood moisture content in relation to ambient relative humidity during fabrication and in installation areas.
- C. Complete fabrication, including assembly, finishing, and hardware application, to maximum extent possible, before shipment to Project site. Disassemble components only as necessary for shipment and installation. Where necessary for fitting at site, provide ample allowance for scribing, trimming, and fitting.

2.5 INTERIOR STANDING AND RUNNING TRIM FOR TRANSPARENT FINISH

- A. Quality Standard: Comply with AWI Section 300.

- B. Grade: **Premium.**

2.6 PLASTIC-LAMINATE CABINETS

- A. Quality Standard: Comply with AWI Section 400 requirements for laminate cabinets.
- B. Grade: **Premium.**
- C. AWI Type of Cabinet Construction: Flush overlay.
- D. Laminate Cladding for Exposed Surfaces: High-pressure decorative laminate complying with the following requirements:
 - 1. Horizontal Surfaces Other Than Tops: HGP.
 - 2. Vertical Surfaces: VGS.
 - 3. Edges: PVC T-mold matching laminate in color, pattern, and finish.
- E. Materials for Semi-exposed Surfaces: Provide surface materials indicated below:
 - 1. Surfaces Other Than Drawer Bodies: High-pressure decorative laminate, Grade VGS.
 - 2. Drawer Sides and Backs: Melamine.
 - 3. Drawer Bottoms: Melamine
- F. Materials for Exposed Surfaces: Plastic Laminate
- G. Retain one each from three groups below or revise to suit Project.
- H. Colors, Patterns, and Finishes: Provide materials and products that result in colors and textures of exposed laminate surfaces complying with the following requirements:
 - 1. Provide Architect's selections from laminate manufacturer's full range of colors and finishes in the following categories:
 - a. Solid colors.
 - b. Patterns.

2.7 PLASTIC-LAMINATE COUNTERTOPS

- A. Quality Standard: Comply with AWI Section 400 requirements for high-pressure decorative laminate countertops.
- B. Grade: **Premium.**
- C. High-Pressure Decorative Laminate Grade: HGS.
- D. Colors, Patterns, and Finishes: Provide materials and products that result in colors and textures of exposed laminate surfaces complying with the following requirements:
 - 1. Provide Architect's selections from manufacturer's full range of colors and finishes in the following categories:

- a. Solid colors.
 - b. Patterns.
- E. Edge Treatment: Countertop front edge shall be bullnose type with same laminate cladding on horizontal surfaces. Side edge, that is visible, shall be finished with same laminate cladding on horizontal surfaces.
- F. Core Material: Shall be ¾" thick solid plywood or high density particle board built up to 1-1/2".
- G. Side Splash: Provide ¾" side splash at all locations where counter abuts perpendicular wall. Side splash shall be attached to wall but not to countertop to allow for expansion or contraction of countertop after installation.

2.8 SOLID-SURFACING-MATERIAL COUNTERTOPS

- A. Grade: Premium.
- B. Solid-Surfacing-Material Thickness: 1/2 inch, Finish 1-1/2"
- C. Colors, Patterns, and Finishes: Provide materials and products that result in colors of solid-surfacing material complying with the following requirements:
- 1. Match project finish schedule. Provide Architect with sample for verification.
- D. Fabricate tops in one piece, unless otherwise indicated. Comply with solid-surfacing-material manufacturer's written recommendations for adhesives, sealers, fabrication, and finishing.
- 1. Fabricate tops with shop-applied edges of materials and configuration indicated.
 - 2. Provide **Integral** back splash.
 - 3. Provide **Integral** side splash where countertop abuts perpendicular wall or cabinet.
 - 4. Provide full bullnose edge at exposed edge of counter.
 - 5. Provide ¾" radius edge at the top of back and side splash.
- E. Integral Sinks: Provide factory fabricated integral sinks where shown and scheduled on Drawings.
- 1. Provide Samsung Staron A1181, Color: Bright White BW010

2.9 Wood Veneer Casework:

- 1. Applicable Standard: AWI Section 400A - Wood Cabinets.
- 2. Grade: Premium.
- 3. Construction Style: Flush overlay.

4. Scribing: Flush with door faces and per Premium Grade regardless of specified casework grade.
5. Materials:
 - a. Exposed Surfaces: Hardwood plywood.
 - b. Semi-Exposed Surfaces: Hardwood Plywood.
 - c. Edges: Wood veneer tape banding to match exposed surfaces, not less than 1/16-inch-thick.

PART 3 - EXECUTION

3.1 PREPARATION

- A. Condition woodwork to average prevailing humidity conditions in installation areas before installation.
- B. Before installing architectural woodwork, examine shop-fabricated work for completion and complete work as required, including removal of packing and backpriming.

3.2 INSTALLATION

- A. Quality Standard: Install woodwork to comply with AWI Section 1700 for the same grade specified in Part 2 of this Section for type of woodwork involved.
- B. Install woodwork level, plumb, true, and straight. Shim as required with concealed shims. Install level and plumb (including tops) to a tolerance of 1/8 inch in 96 inches.
- C. Scribe and cut woodwork to fit adjoining work, and refinish cut surfaces and repair damaged finish at cuts.
- D. Anchor woodwork to anchors or blocking built in or directly attached to substrates. Secure with countersunk, concealed fasteners and blind nailing as required for complete installation.
- E. Standing and Running Trim: Install with minimum number of joints possible, using full-length pieces (from maximum length of lumber available) to greatest extent possible. Do not use pieces less than 36 inches long, except where shorter single-length pieces are necessary.
- F. Cabinets: Install without distortion so doors and drawers fit openings properly and are accurately aligned. Adjust hardware to center doors and drawers in openings and to provide unencumbered operation. Complete installation of hardware and accessory items as indicated.
 1. Install cabinets with no more than 1/8 inch in 96-inch sag, bow, or other variation from a straight line.
 2. Fasten wall cabinets through back, near top and bottom, at ends and not more than 16 inches o.c. with No. 10 wafer-head screws sized for 1-inch penetration into wood framing, blocking, or hanging strips.

- G. Countertops: Anchor securely by screwing through corner blocks of base cabinets or other supports into underside of countertop.
1. Install countertops with no more than 1/8 inch in 96-inch sag, bow, or other variation from a straight line.
 2. Secure backsplashes to tops and to walls.
 3. Calk space between backsplash and wall with sealant specified in Division 7 Section "Joint Sealants."
 4. Cut circular openings in countertop for electrical cord access below countertop. Provide a grommet around opening for finish appearance. Color of grommet to match countertop. The number of openings required will be determined by the Owner but will not exceed 250.
 5. Cut openings in countertops for the installation of grilles as indicated on the drawings and as approved by Architect.
 6. Provide full bullnose edge, Typical all sides

3.3 ADJUSTING AND CLEANING

- A. Repair damaged and defective woodwork, where possible, to eliminate functional and visual defects; where not possible to repair, replace woodwork. Adjust joinery for uniform appearance.
- B. Clean, lubricate, and adjust hardware.
- C. Clean woodwork on exposed and semi-exposed surfaces. Touch up shop-applied finishes to restore damaged or soiled areas.

END OF SECTION

SECTION 07 21 00 - THERMAL INSULATION

PART 1 - GENERAL

1.1 RELATED DOCUMENTS

- A. Drawings and general provisions of the Contract, including General and Supplementary Conditions and Division 01 Specification Sections, apply to this Section.

1.2 SUMMARY

A. Section Includes:

1. Extruded polystyrene foam-plastic board insulation (at perimeter foundation wall below grade and at other places indicated on drawings).
2. Polyisocyanurate foam-plastic board insulation (in cavity walls, furred CMU walls, above grade locations that are not scheduled for spray applied foam type insulation).
3. Glass-fiber blanket insulation.
4. Glass-fiber board insulation.
5. Mineral-wool blanket insulation.
6. Mineral-wool board insulation.
7. Loose-fill insulation.
8. Spray-applied cellulosic insulation.

B. Related Requirements:

1. Section 04 2000 "Unit Masonry" for insulation installed in masonry cells.
2. Section 06 1600 "Sheathing" for foam-plastic board sheathing installed directly over wood or steel framing.
3. Section 07 1326 "Self-Adhering Sheet Waterproofing"
4. Section 07 2119 "Foamed-in-Place Insulation" for spray-applied polyurethane foam insulation.
5. Section 07 5419 "Polyvinyl-Chloride (PVC) Roofing" for insulation specified as part of roofing construction.
6. Section 09 2900 "Gypsum Board" for sound attenuation blanket used as acoustic insulation.

1.3 ACTION SUBMITTALS

A. Product Data: For the following:

1. Extruded polystyrene foam-plastic board insulation.
2. Polyisocyanurate foam-plastic board insulation.
3. Glass-fiber blanket insulation.
4. Glass-fiber board insulation.
5. Mineral-wool blanket insulation.
6. Mineral-wool board insulation.

7. Loose-fill insulation.

1.4 INFORMATIONAL SUBMITTALS

- A. Installer's Certification: Listing type, manufacturer, and R-value of insulation installed in each element of the building thermal envelope.
 1. For blown-in or sprayed fiberglass and cellulosic-fiber loose-fill insulation, indicate initial installed thickness, settled thickness, settled R-value, installed density, coverage area, and number of bags installed.
 2. Sign, date, and post the certification in a conspicuous location on Project site.
- B. Product Test Reports: For each product, for tests performed by a qualified testing agency.
- C. Research Reports: For foam-plastic insulation, from ICC-ES.

1.5 DELIVERY, STORAGE, AND HANDLING

- A. Protect insulation materials from physical damage and from deterioration due to moisture, soiling, and other sources. Store inside and in a dry location. Comply with manufacturer's written instructions for handling, storing, and protecting during installation.
- B. Protect foam-plastic board insulation as follows:
 1. Do not expose to sunlight except to necessary extent for period of installation and concealment.
 2. Protect against ignition at all times. Do not deliver foam-plastic board materials to Project site until just before installation time.
 3. Quickly complete installation and concealment of foam-plastic board insulation in each area of construction.

PART 2 - PRODUCTS

2.1 EXTRUDED POLYSTYRENE FOAM-PLASTIC BOARD INSULATION

- A. Extruded Polystyrene Board Insulation, Type IV: ASTM C578, Type IV, 25-psi minimum compressive strength; unfaced.
 1. Manufacturers: Subject to compliance with requirements, provide products by one of the following:
 - a. DiversiFoam Products.
 - b. Dow Chemical Company (The).
 - c. Kingspan Insulation Limited.
 - d. Owens Corning.
 2. Flame-Spread Index: Not more than 25 when tested in accordance with ASTM E84.

3. Smoke-Developed Index: Not more than 450 when tested in accordance with ASTM E84.
4. Fire Propagation Characteristics: Passes NFPA 285 testing as part of an approved assembly.

2.2 POLYISOCYANURATE FOAM-PLASTIC BOARD INSULATION

- A. Polyisocyanurate Board Insulation, Foil Faced: ASTM C1289, foil faced, Type I, Class 1 or 2.
 1. Manufacturers: Subject to compliance with requirements, available manufacturers offering products that may be incorporated into the Work include, but are not limited to the following:
 - a. Atlas EPS; a Division of Atlas Roofing Corporation.
 - b. Atlas Roofing Corporation.
 - c. Carlisle Coatings & Waterproofing Inc.
 - d. Dow Chemical Company (The).
 - e. Firestone Building Products.
 - f. Hunter Panels.
 - g. Johns Manville; a Berkshire Hathaway company.
 - h. Rmax, Inc.
 2. Fire Propagation Characteristics: Passes NFPA 285 testing as part of an approved assembly.
 3. Labeling: Provide identification of mark indicating R-value of each piece of insulation 12 inches and wider in width.
- B. Glass-Fiber Blanket Insulation, Kraft-faced: ASTM C665, Type I; passing ASTM E136 for combustion characteristics.
 1. Manufacturers: Subject to compliance with requirements, available manufacturers offering products that may be incorporated into the Work include, but are not limited to the following:
 - a. CertainTeed Corporation.
 - b. Johns Manville; a Berkshire Hathaway company.
 - c. Knauf Insulation.
 - d. Owens Corning.
 2. Flame-Spread Index: Not more than 25 when tested in accordance with ASTM E84.
 3. Smoke-Developed Index: Not more than 50 when tested in accordance with ASTM E84.
 4. Labeling: Provide identification of mark indicating R-value of each piece of insulation 12 inches and wider in width.

2.3 MINERAL-WOOL BLANKET INSULATION

- A. Mineral-Wool Blanket Insulation, Unfaced: ASTM C665, Type IA (blankets without membrane facing); consisting of fibers; passing ASTM E136 for combustion characteristics.

1. Manufacturers: Subject to compliance with requirements, available manufacturers offering products that may be incorporated into the Work include, but are not limited to the following:
 - a. Johns Manville; a Berkshire Hathaway company.
 - b. Rockwool International.
 - c. Thermafiber, Inc.; an Owens Corning company.
 2. Flame-Spread Index: Not more than 25 when tested in accordance with ASTM E84.
 3. Smoke-Developed Index: Not more than 50 when tested in accordance with ASTM E84.
 4. Labeling: Provide identification of mark indicating R-value of each piece of insulation 12 inches and wider in width.
- B. Mineral-Wool Blanket Insulation, Reinforced-Foil Faced: ASTM C665, Type III (reflective faced); Category 1 (membrane is a vapor barrier), faced with foil scrim, foil-scrim kraft, or foil-scrim polyethylene.
1. Manufacturers: Subject to compliance with requirements, available manufacturers offering products that may be incorporated into the Work include, but are not limited to the following:
 - a. Thermafiber, Inc.; an Owens Corning company.
 2. Flame-Spread Index: Not more than 25 when tested in accordance with ASTM E84.
 3. Smoke-Developed Index: Not more than 50 when tested in accordance with ASTM E84.
 4. Labeling: Provide identification of mark indicating R-value of each piece of insulation 12 inches and wider in width.
- 2.4 LOOSE-FILL INSULATION
- A. Cellulosic-Fiber Borate Treated Blown-In Insulation: ASTM C739, chemically treated for flame-resistance, processing, and handling characteristics.
1. Manufacturers: Subject to compliance with requirements, available manufacturers offering products that may be incorporated into the Work include, but are not limited to the following:
 - a. GreenFiber.
 - b. Hamilton Manufacturing Inc.
 - c. Nu-Wool Co., Inc.
- 2.5 INSULATION FASTENERS
- A. Adhesively Attached, Spindle-Type Anchors: Plate welded to projecting spindle; capable of holding insulation of specified thickness securely in position with self-locking washer in place.

1. Manufacturers: Subject to compliance with requirements, available manufacturers offering products that may be incorporated into the Work include, but are not limited to the following:
 - a. AGM Industries, Inc.
 - b. Gemco.
 2. Plate: Perforated, galvanized carbon-steel sheet, 0.030 inch thick by 2 inches square.
 3. Spindle: Copper-coated, low-carbon steel; fully annealed; 0.105 inch in diameter; length to suit depth of insulation.
- B. Adhesively Attached, Angle-Shaped, Spindle-Type Anchors: Angle welded to projecting spindle; capable of holding insulation of specified thickness securely in position with self-locking washer in place.
1. Manufacturers: Subject to compliance with requirements, available manufacturers offering products that may be incorporated into the Work include, but are not limited to the following:
 - a. Gemco.
 2. Angle: Formed from 0.030-inch-thick, perforated, galvanized carbon-steel sheet with each leg 2 inches square.
 3. Spindle: Copper-coated, low-carbon steel; fully annealed; 0.105 inch in diameter; length to suit depth of insulation.
- C. Insulation-Retaining Washers: Self-locking washers formed from 0.016-inch-thick galvanized-steel sheet, with beveled edge for increased stiffness, sized as required to hold insulation securely in place, but not less than 1-1/2 inches square or in diameter.
1. Manufacturers: Subject to compliance with requirements, available manufacturers offering products that may be incorporated into the Work include, but are not limited to the following:
 - a. AGM Industries, Inc.
 - b. Gemco.
 2. Protect ends with capped self-locking washers incorporating a spring steel insert to ensure permanent retention of cap in the following locations:
 - a. Crawl spaces.
 - b. Ceiling plenums.
 - c. Attic spaces.
- D. Insulation Standoff: Spacer fabricated from galvanized mild-steel sheet for fitting over spindle of insulation anchor to maintain air space of 1 inch between face of insulation and substrate to which anchor is attached.
1. Manufacturers: Subject to compliance with requirements, available manufacturers offering products that may be incorporated into the Work include, but are not limited to the following:
 - a. Gemco.

- E. Anchor Adhesive: Product with demonstrated capability to bond insulation anchors securely to substrates without damaging insulation, fasteners, or substrates.
 - 1. Manufacturers: Subject to compliance with requirements, available manufacturers offering products that may be incorporated into the Work include, but are not limited to the following:
 - a. AGM Industries, Inc.
 - b. Gemco.

2.6 ACCESSORIES

- A. Insulation for Miscellaneous Voids:
 - 1. Glass-Fiber Insulation: ASTM C764, Type II, loose fill; with maximum flame-spread and smoke-developed indexes of 5, per ASTM E84.
 - 2. Spray Polyurethane Foam Insulation: ASTM C1029, Type II, closed cell, with maximum flame-spread and smoke-developed indexes of 75 and 450, respectively, per ASTM E84.
- B. Adhesive for Bonding Insulation: Product compatible with insulation and air and water barrier materials, and with demonstrated capability to bond insulation securely to substrates without damaging insulation and substrates.
- C. Asphalt Coating for Cellular-Glass Block Insulation: Cutback asphalt or asphalt emulsion of type recommended by manufacturer of cellular-glass block insulation.
- D. Eave Ventilation Troughs: Preformed, rigid fiberboard or plastic sheets designed and sized to fit between roof framing members and to provide ventilation between insulated attic spaces and vented eaves.

PART 3 - EXECUTION

3.1 PREPARATION

- A. Clean substrates of substances that are harmful to insulation, including removing projections capable of puncturing insulation or vapor retarders, or that interfere with insulation attachment.

3.2 INSTALLATION, GENERAL

- A. Comply with insulation manufacturer's written instructions applicable to products and applications.
- B. Install insulation that is undamaged, dry, and unsoiled and that has not been left exposed to ice, rain, or snow at any time.
- C. Install insulation with manufacturer's R-value label exposed after insulation is installed.

- D. Extend insulation to envelop entire area to be insulated. Fit tightly around obstructions and fill voids with insulation. Remove projections that interfere with placement.
- E. Provide sizes to fit applications and selected from manufacturer's standard thicknesses, widths, and lengths. Apply single layer of insulation units unless multiple layers are otherwise shown or required to make up total thickness or to achieve R-value.

3.3 INSTALLATION OF SLAB INSULATION

- A. On vertical slab edge and foundation surfaces, set insulation units using manufacturer's recommended adhesive according to manufacturer's written instructions.
 - 1. If not otherwise indicated, extend insulation a minimum of 36 inches below exterior grade line.
- B. On horizontal surfaces, loosely lay insulation units according to manufacturer's written instructions. Stagger end joints and tightly abut insulation units.
 - 1. If not otherwise indicated, extend insulation a minimum of 24 inches in from exterior walls.

3.4 INSTALLATION OF FOUNDATION WALL INSULATION

- A. Butt panels together for tight fit.
- B. Anchor Installation: Install board insulation on concrete substrates by adhesively attached, spindle-type insulation anchors as follows:
 - 1. Fasten insulation anchors to concrete substrates with insulation anchor adhesive according to anchor manufacturer's written instructions.
 - 2. Space anchors according to insulation manufacturer's written instructions for insulation type, thickness, and application.
 - 3. Apply insulation standoffs to each spindle to create cavity width indicated on Drawings between concrete substrate and insulation.
 - 4. After adhesive has dried, install board insulation by pressing insulation into position over spindles and securing it tightly in place with insulation-retaining washers, taking care not to compress insulation.
 - 5. Where insulation will not be covered by other building materials, apply capped washers to tips of spindles.
- C. Adhesive Installation: Install with adhesive or press into tacky waterproofing or dampproofing according to manufacturer's written instructions.

3.5 INSTALLATION OF CAVITY-WALL INSULATION

- A. Foam-Plastic Board Insulation: Install pads of adhesive spaced approximately 24 inches o.c. both ways on inside face and as recommended by manufacturer.
 - 1. Fit courses of insulation between wall ties and other obstructions, with edges butted tightly in both directions, and with faces flush.

2. Press units firmly against inside substrates.
3. Supplement adhesive attachment of insulation by securing boards with two-piece wall ties designed for this purpose and specified in Section 04 2000 "Unit Masonry."

3.6 INSTALLATION OF INSULATION IN FRAMED CONSTRUCTION

- A. Blanket Insulation: Install in cavities formed by framing members according to the following requirements:
1. Use insulation widths and lengths that fill the cavities formed by framing members. If more than one length is required to fill the cavities, provide lengths that will produce a snug fit between ends.
 2. Place insulation in cavities formed by framing members to produce a friction fit between edges of insulation and adjoining framing members.
 3. Maintain 3-inch clearance of insulation around recessed lighting fixtures not rated for or protected from contact with insulation.
 4. For metal-framed wall cavities where cavity heights exceed 96 inches, support unfaced blankets mechanically and support faced blankets by taping flanges of insulation to flanges of metal studs.
- B. Miscellaneous Voids: Install insulation in miscellaneous voids and cavity spaces where required to prevent gaps in insulation using the following materials:
1. Glass-Fiber Insulation: Compact to approximately 40 percent of normal maximum volume equaling a density of approximately 2.5 lb/cu. ft..
 2. Spray Polyurethane Insulation: Apply according to manufacturer's written instructions.
- C. Loose-Fill Insulation: Apply according to ASTM C1015 and manufacturer's written instructions.
1. Level horizontal applications to uniform thickness as indicated, lightly settle to uniform density, but do not compact excessively.
 2. For cellulosic-fiber loose-fill insulation, comply with CIMA's Bulletin #2, "Standard Practice for Installing Cellulose Insulation."

3.7 INSTALLATION OF CURTAIN-WALL INSULATION

- A. Install board insulation in curtain-wall construction according to curtain-wall manufacturer's written instructions.
1. Hold insulation in place by securing metal clips and straps or integral pockets within window frames, spaced at intervals recommended in writing by insulation manufacturer to hold insulation securely in place without touching spandrel glass.
 2. Maintain cavity width of dimension indicated on Drawings between insulation and glass.
 3. Install insulation to fit snugly without bowing.

3.8 PROTECTION

- A. Protect installed insulation from damage due to harmful weather exposures, physical abuse, and other causes.
- B. Provide temporary coverings or enclosures where insulation is subject to abuse and cannot be concealed and protected by permanent construction immediately after installation.

END OF SECTION

SECTION 07 72 00 - ROOF ACCESSORIES

PART 1 - GENERAL

1.1 RELATED DOCUMENTS

- A. Drawings and general provisions of the Contract, including General and Supplementary Conditions and Division 01 Specification Sections, apply to this Section.

1.2 SUMMARY

A. Section Includes:

1. Roof curbs.
2. Equipment supports.
3. Roof hatches.
4. Hatch-type heat and smoke vents.
5. Dropout-type heat and smoke vents.
6. Gravity ventilators.
7. Pipe and duct supports.
8. Pipe portals.
9. Preformed flashing sleeves.
10. Roof walkways.

B. Related Sections:

1. Section 055000 "Metal Fabrications" for metal vertical ladders, ships' ladders, and stairs for access to roof hatches.
2. Section 076200 "Sheet Metal Flashing and Trim" for shop- and field-formed metal flashing, roof-drainage systems, roof expansion-joint covers, and miscellaneous sheet metal trim and accessories.
3. Section 077100 "Roof Specialties" for manufactured fasciae, copings, gravel stops, gutters and downspouts, and counterflashing.
4. Section 230548 "Vibration and Seismic Controls for HVAC" for special curbs designed to accommodate seismic and vibration controls.
5. Section 233423 "HVAC Power Ventilators" for power roof-mounted ventilators.
6. Section 237413 "Packaged, Outdoor, Central-Station Air-Handling Units" for standard curbs specified with rooftop units.

1.3 COORDINATION

- A. Coordinate layout and installation of roof accessories with roofing membrane and base flashing and interfacing and adjoining construction to provide a leakproof, weathertight, secure, and noncorrosive installation.
- B. Coordinate dimensions with rough-in information or Shop Drawings of equipment to be supported.

1.4 ACTION SUBMITTALS

- A. Product Data: For each type of roof accessory.
 - 1. Include construction details, material descriptions, dimensions of individual components and profiles, and finishes.
- B. Shop Drawings: For roof accessories.
 - 1. Include plans, elevations, keyed details, and attachments to other work. Indicate dimensions, loadings, and special conditions. Distinguish between plant- and field-assembled work.
- C. Samples: For each exposed product and for each color and texture specified, prepared on Samples of size to adequately show color.
- D. Delegated-Design Submittal: For roof curbs, equipment supports and walkways indicated to comply with performance requirements and design criteria, including analysis data signed and sealed by the qualified professional engineer responsible for their preparation.
 - 1. Detail mounting, securing, and flashing of roof-mounted items to roof structure. Indicate coordinating requirements with roof membrane system.
 - 2. Wind-Restraint Details: Detail fabrication and attachment of wind restraints. Show anchorage details and indicate quantity, diameter, and depth of penetration of anchors.

1.5 INFORMATIONAL SUBMITTALS

- A. Coordination Drawings: Roof plans, drawn to scale, and coordinating penetrations and roof-mounted items. Show the following:
 - 1. Size and location of roof accessories specified in this Section.
 - 2. Method of attaching roof accessories to roof or building structure.
 - 3. Other roof-mounted items including mechanical and electrical equipment, ductwork, piping, and conduit.
 - 4. Required clearances.
- B. Sample Warranties: For manufacturer's special warranties.

1.6 CLOSEOUT SUBMITTALS

- A. Operation and Maintenance Data: For roof accessories to include in operation and maintenance manuals.

1.7 WARRANTY

- A. Special Warranty on Painted Finishes: Manufacturer's standard form in which manufacturer agrees to repair finishes or replace roof accessories that show evidence of deterioration of factory-applied finishes within specified warranty period.

1. Fluoropolymer Finish: Deterioration includes, but is not limited to, the following:
 - a. Color fading more than 5 Hunter units when tested according to ASTM D 2244.
 - b. Chalking in excess of a No. 8 rating when tested according to ASTM D 4214.
 - c. Cracking, checking, peeling, or failure of paint to adhere to bare metal.
2. Finish Warranty Period: 10 years from date of Substantial Completion.

PART 2 - PRODUCTS

2.1 PERFORMANCE REQUIREMENTS

- A. General Performance: Roof accessories shall withstand exposure to weather and resist thermally induced movement without failure, rattling, leaking, or fastener disengagement due to defective manufacture, fabrication, installation, or other defects in construction.
- B. Delegated Design: Engage a qualified professional engineer, as defined in Section 014000 "Quality Requirements," to design roof curbs and equipment supports to comply with wind performance requirements, including comprehensive engineering analysis by a qualified professional engineer, using performance requirements and design criteria indicated.

2.2 ROOF CURBS

- A. Roof Curbs: Internally reinforced roof-curb units capable of supporting superimposed live and dead loads, including equipment loads and other construction indicated on Drawings, bearing continuously on roof structure, and capable of meeting performance requirements; with welded or mechanically fastened and sealed corner joints integral metal cant and integrally formed deck-mounting flange at perimeter bottom.
 1. Manufacturers: Subject to compliance with requirements, provide products by one of the following:
 - a. Adaptable Air Products.
 - b. AES Industries, Inc.
 - c. Air Balance Inc.; a division of MESTEK, Inc.
 - d. Bristolite Daylighting Systems, Inc.
 - e. Conn-Fab Sales, Inc.
 - f. Curbs Plus, Inc.
 - g. Custom Solution Roof and Metal Products.
 - h. Greenheck Fan Corporation.
 - i. KCC International Inc.
 - j. Lloyd Industries, Inc.
 - k. LMCurbs.
 - l. Louvers & Dampers, Inc.; a division of Mestek, Inc.
 - m. Metallic Products Corp.
 - n. Milcor; Commercial Products Group of Hart & Cooley, Inc.

- o. Pate Company (The).
 - p. Plenums Incorporated.
 - q. Roof Curb Systems.
 - r. Roof Products and Systems (RPS); a division of Hart & Cooley, Inc.
 - s. Roof Products, Inc.
 - t. Safe Air of Illinois.
 - u. Thybar Corporation.
 - v. Vent Products Co., Inc.
- B. Size: Coordinate dimensions with roughing-in information or Shop Drawings of equipment to be supported.
- C. Supported Load Capacity: As indicated in drawings.
- D. Material: Aluminum sheet, 0.125 inch thick.
- 1. Finish: Color anodic.
 - 2. Color: As selected by Architect from manufacturer's full range.
- E. Construction:
- 1. Curb Profile: Manufacturer's standard compatible with roofing system.
 - 2. On ribbed or fluted metal roofs, form deck-mounting flange at perimeter bottom to conform to roof profile.
 - 3. Fabricate curbs to minimum height of 12 inches above roofing surface unless otherwise indicated.
 - 4. Top Surface: Level top of curb, with roof slope accommodated by sloping deck-mounting flange.
 - 5. Sloping Roofs: Where roof slope exceeds 1:48, fabricate curb with perimeter curb height tapered to accommodate roof slope so that top surface of perimeter curb is level. Equip unit with water diverter or cricket on side that obstructs water flow.
 - 6. Insulation: Factory insulated with 1-1/2-inch-thick glass-fiber board insulation.
 - 7. Liner: Same material as curb, of manufacturer's standard thickness and finish.
 - 8. Nailer: Factory-installed wood nailer under top flange on side of curb, continuous around curb perimeter.
 - 9. Wind Restraint Straps and Base Flange Attachment: Provide wind restraint straps, welded strap connectors, and base flange attachment to roof structure at perimeter of curb, of size and spacing required to meet wind uplift requirements.
 - 10. Platform Cap: Where portion of roof curb is not covered by equipment, provide weathertight platform cap formed from 3/4-inch (19-mm) thick plywood covered with metal sheet of same type, thickness, and finish as required for curb.
 - 11. Metal Counterflashing: Manufacturer's standard, removable, fabricated of same metal and finish as curb.
 - 12. Security Grille: Provide for all units.
 - 13. Damper Tray: Provide damper tray or shelf with opening 3 inches less than interior curb dimensions indicated.

2.3 EQUIPMENT SUPPORTS

- A. Equipment Supports: Rail-type metal equipment supports capable of supporting superimposed live and dead loads between structural supports, including equipment loads and other construction indicated on Drawings, spanning between structural supports; capable of meeting performance requirements; with welded corner joints, integral metal cant, and integrally formed structure-mounting flange at bottom.
1. Manufacturers: Subject to compliance with requirements, provide products by one of the following:
 - a. Adaptable Air Products.
 - b. AES Industries, Inc.
 - c. Air Balance Inc.; a division of MESTEK, Inc.
 - d. Conn-Fab Sales, Inc.
 - e. Curbs Plus, Inc.
 - f. Custom Solution Roof and Metal Products.
 - g. Greenheck Fan Corporation.
 - h. KCC International Inc.
 - i. Lloyd Industries, Inc.
 - j. LMCurbs.
 - k. Louvers & Dampers, Inc.; a division of Mestek, Inc.
 - l. Milcor; Commercial Products Group of Hart & Cooley, Inc.
 - m. Pate Company (The).
 - n. Plenums Incorporated.
 - o. Roof Curb Systems.
 - p. Roof Products and Systems (RPS); a division of Hart & Cooley, Inc.
 - q. Roof Products, Inc.
 - r. Thybar Corporation.
 - s. Vent Products Co., Inc.
- B. Size: Coordinate dimensions with roughing-in information or Shop Drawings of equipment to be supported.
- C. Supported Load Capacity: As indicated in drawings.
- D. Material: Aluminum sheet, 0.125 inch thick.
1. Finish: Color anodic.
 2. Color: As selected by Architect from manufacturer's full range.
- E. Construction:
1. Curb Profile: Manufacturer's standard compatible with roofing system.
 2. Insulation: Factory insulated with 1-1/2-inch-thick glass-fiber board insulation.
 3. Liner: Same material as equipment support, of manufacturer's standard thickness and finish.
 4. Nailer: Factory-installed continuous wood nailers 5-1/2 inches wide under top flange on side of curb, continuous around support perimeter.
 5. Wind Restraint Straps and Base Flange Attachment: Provide wind restraint straps, welded strap connectors, and base flange attachment to roof structure at perimeter of curb of size and spacing required to meet wind uplift requirements.

6. Platform Cap: Where portion of equipment support is not covered by equipment, provide weathertight platform cap formed from 3/4-inch (19-mm) thick plywood covered with metal sheet of same type, thickness, and finish as required for curb.
7. Metal Counterflashing: Manufacturer's standard, removable, fabricated of same metal and finish as equipment support.
8. On ribbed or fluted metal roofs, form deck-mounting flange at perimeter bottom to conform to roof profile.
9. Fabricate equipment supports to minimum height of 12 inches above roofing surface unless otherwise indicated.
10. Sloping Roofs: Where roof slope exceeds 1:48, fabricate each support with height to accommodate roof slope so that tops of supports are level with each other. Equip supports with water diverters or crickets on sides that obstruct water flow.
11. Security Grille: Provide for all units.

2.4 ROOF HATCH

- A. ~~Roof Hatches: Metal roof hatch units with insulated double wall lids and insulated double-walled curbs, welded or mechanically fastened and sealed corner joints, continuous lid-to-curb counterflashing and weathertight perimeter gasketing integral metal cant and integrally formed deck-mounting flange at perimeter bottom. Provide with hot-dip galvanized hardware.~~
1. ~~Manufacturers: Subject to compliance with requirements, provide products by one of the following:~~
- a. ~~Adaptable Air Products.~~
 - b. ~~AES Industries, Inc.~~
 - c. ~~Air Balance Inc.; a division of MESTEK, Inc.~~
 - d. ~~Conn Fab Sales, Inc.~~
 - e. ~~Curbs Plus, Inc.~~
 - f. ~~Custom Solution Roof and Metal Products.~~
 - g. ~~Greenheck Fan Corporation.~~
 - h. ~~KCC International Inc.~~
 - i. ~~Lloyd Industries, Inc.~~
 - j. ~~LMCurbs.~~
 - k. ~~Louvers & Dampers, Inc.; a division of Mestek, Inc.~~
 - l. ~~Milcor; Commercial Products Group of Hart & Cooley, Inc.~~
 - m. ~~Pate Company (The).~~
 - n. ~~Plenums Incorporated.~~
 - o. ~~Roof Curb Systems.~~
 - p. ~~Roof Products and Systems (RPS); a division of Hart & Cooley, Inc.~~
 - q. ~~Roof Products, Inc.~~
 - r. ~~Thybar Corporation.~~
 - s. ~~Vent Products Co., Inc.~~
- B. ~~Type and Size: Single leaf lid, 36 by 36 inches.~~
- C. ~~Loads: Minimum 40-lbf/sq. ft. external live load and 20-lbf/sq. ft. internal uplift load.~~
- D. ~~Hatch Material: Zinc-coated (galvanized).~~

1. Thickness: 0.079 inch.
2. Finish: Baked enamel.
3. Color: As selected by Architect from manufacturer's full range.

E. Construction:

1. Insulation: Polyisocyanurate board.
 - a. R-Value: 12.0 according to ASTM C 1363.
2. Nailer: Factory-installed wood nailer continuous around hatch perimeter.
3. Hatch Lid: Opaque, insulated, and double walled, with manufacturer's standard metal liner of same material and finish as outer metal lid.
4. Curb Liner: Manufacturer's standard, of same material and finish as metal curb.
5. On-ribbed or fluted metal roofs, form flange at perimeter bottom to conform to roof profile.
6. Fabricate curbs to minimum height of 12 inches above roofing surface unless otherwise indicated.
7. Sloping Roofs: Where slope or roof deck exceeds 1:48, fabricate curb with perimeter curb height that is tapered to accommodate roof slope so that top surfaces of perimeter curb are level. Equip hatch with water diverter or cricket on side that obstructs water flow.
8. Safety

F. Hardware: Spring operators, hold-open arm, galvanized steel spring latch with turn handles, galvanized steel butt or pintle-type hinge system, and padlock hasps inside and outside.

1. Provide two-point latch on lids larger than 84 inches.
2. Provide remote-control operation.

2.5 PIPE AND DUCT SUPPORTS

- A. Fixed-Height Cradle-Type Pipe Supports: Polycarbonate pipe stand accommodating up to 1-1/2-inch-diameter pipe or conduit; with provision for pipe retainer and with manufacturer's support pad or deck plate as recommended for penetration-free installation over roof membrane type; as required for quantity of pipe runs and sizes.
- B. Duct Supports: Extruded-aluminum, urethane-insulated supports, 2 inches in diameter; with manufacturer's recommended hardware for mounting to structure or structural roof deck.
 1. Finish: Manufacturer's standard.

2.6 PIPE PORTALS

- A. Curb-Mounted Pipe Portal: Insulated roof-curb units with welded or mechanically fastened and sealed corner joints, integral metal cant and integrally formed deck-mounting flange at perimeter bottom; with weathertight curb cover with single or multiple collared openings and pressure-sealed conically shaped EPDM protective rubber caps sized for piping indicated, with stainless-steel snaplock swivel clamps.

- B. Flashing Pipe Portal: Formed aluminum membrane-mounting flashing flange and sleeve with collared opening and pressure-sealed conically shaped EPDM protective rubber cap sized for piping indicated, with stainless-steel snaplock swivel clamps.

2.7 PREFORMED FLASHING SLEEVES

- A. Exhaust Vent Flashing: Double-walled metal flashing sleeve or boot, insulation filled, with integral deck flange, 12 inches high, with removable metal hood and slotted metal collar.
 - 1. Metal: Aluminum sheet, 0.063 inch (1.60 mm) thick.
 - 2. Diameter: 6 inches.
 - 3. Finish: Manufacturer's standard.
- B. Vent Stack Flashing: Metal flashing sleeve, uninsulated, with integral deck flange.
 - 1. Metal: Aluminum sheet, 0.063 inch.
 - 2. Height: 13 inches.
 - 3. Diameter: 6 inches.
 - 4. Finish: Manufacturer's standard.

2.8 ROOF WALKWAYS

- 1. Manufacturers
 - a. Carlisle Syntec Systems
- 2. Product: Sure-Flex PVC Walkway Rolls.
- 3. Walkway Width: 36 inches.
- 4. Wind Restraint: Provide wind restraint attachment to roof structure of size and spacing required to meet wind uplift requirements.
- 5. Finish: Manufacturer's standard.

2.9 METAL MATERIALS

- A. Aluminum Sheet: ASTM B 209, manufacturer's standard alloy for finish required, with temper to suit forming operations and performance required.
 - 1. Mill Finish: As manufactured.
 - 2. Factory Prime Coating: Where field painting is indicated, apply pretreatment and white or light-colored, factory-applied, baked-on epoxy primer coat, with a minimum dry film thickness of 0.2 mil.
 - 3. Color Anodic Finish: AAMA 611, AA-M12C22A42/A44, Class I, 0.018 mm or thicker.
 - 4. Exposed Coil-Coated Finish: Prepare, pretreat, and apply coating to exposed metal surfaces to comply with coating and resin manufacturers' written instructions.
 - a. Two-Coat Fluoropolymer Finish: AAMA 2605. System consisting of primer and fluoropolymer color topcoat containing not less than 70 percent PVDF resin by weight.

5. Baked-Enamel or Powder-Coat Finish: AAMA 2603 except with a minimum dry film thickness of 1.5 mils. Comply with coating manufacturer's written instructions for cleaning, conversion coating, and applying and baking finish.
 6. Concealed Finish: Pretreat with manufacturer's standard white or light-colored acrylic or polyester-backer finish consisting of prime coat and wash coat, with a minimum total dry film thickness of 0.5 mil.
- B. Aluminum Extrusions and Tubes: ASTM B 221, manufacturer's standard alloy and temper for type of use, finished to match assembly where used; otherwise mill finished.
 - C. Stainless-Steel Sheet and Shapes: ASTM A 240/A 240M or ASTM A 666, Type 304.
 - D. Steel Shapes: ASTM A 36/A 36M, hot-dip galvanized according to ASTM A 123/A 123M unless otherwise indicated.
 - E. Steel Tube: ASTM A 500/A 500M, round tube.
 - F. Galvanized-Steel Tube: ASTM A 500/A 500M, round tube, hot-dip galvanized according to ASTM A 123/A 123M.
 - G. Steel Pipe: ASTM A 53/A 53M, galvanized.

2.10 MISCELLANEOUS MATERIALS

- A. General: Provide materials and types of fasteners, protective coatings, sealants, and other miscellaneous items required by manufacturer for a complete installation.
- B. Polyisocyanurate Board Insulation: ASTM C 1289, thickness and thermal resistivity as indicated.
- C. Wood Nailers: Softwood lumber, pressure treated with waterborne preservatives for aboveground use, acceptable to authorities having jurisdiction and complying with AWPA C2; not less than 1-1/2 inches thick.
- D. Security Grilles: 3/4-inch diameter, ASTM A 1011/A 1011M steel bars spaced 6 inches o.c. in one direction and 12 inches o.c. in the other; factory finished as follows:
 1. Surface Preparation: Remove mill scale and rust, if any, from uncoated steel, complying with SSPC-SP 5/NACE No. 1, "White Metal Blast Cleaning," or SSPC-SP 8, "Pickling."
 2. Factory Priming for Field-Painted Finish: Apply shop primer specified below immediately after surface preparation and pretreatment.
 3. Shop Primer: Manufacturer's or fabricator's standard, fast-curing, lead- and chromate-free, universal primer; selected for resistance to normal atmospheric corrosion, for compatibility with substrate and field-applied finish paint system indicated, and for capability to provide a sound foundation for field-applied topcoats under prolonged exposure.
- E. Bituminous Coating: Cold-applied asphalt emulsion complying with ASTM D 1187/D 1187M.
- F. Underlayment:

1. Felt: ASTM D 226/D 226M, Type II (No. 30), asphalt-saturated organic felt, nonperforated.
 2. Polyethylene Sheet: 6-mil-thick polyethylene sheet complying with ASTM D 4397.
 3. Slip Sheet: Building paper, 3 lb/100 sq. ft. minimum, rosin sized.
 4. Self-Adhering, High-Temperature Sheet: Minimum 30 to 40 mils thick, consisting of slip-resisting polyethylene-film top surface laminated to layer of butyl or SBS-modified asphalt adhesive, with release-paper backing; cold applied. Provide primer when recommended by underlayment manufacturer.
 5. Fasteners: Roof accessory manufacturer's recommended fasteners suitable for application and metals being fastened. Match finish of exposed fasteners with finish of material being fastened. Provide nonremovable fastener heads to exterior exposed fasteners. Furnish the following unless otherwise indicated:
 6. Fasteners for Zinc-Coated or Aluminum-Zinc Alloy-Coated Steel: Series 300 stainless steel or hot-dip zinc-coated steel according to ASTM A 153/A 153M or ASTM F 2329.
 7. Fasteners for Aluminum Sheet: Aluminum or Series 300 stainless steel.
 8. Fasteners for Stainless-Steel Sheet: Series 300 stainless steel.
- G. Gaskets: Manufacturer's standard tubular or fingered design of neoprene, EPDM, PVC, or silicone or a flat design of foam rubber, sponge neoprene, or cork.
- H. Elastomeric Sealant: ASTM C 920, elastomeric polyurethane polymer sealant as recommended by roof accessory manufacturer for installation indicated; low modulus; of type, grade, class, and use classifications required to seal joints and remain watertight.
- I. Butyl Sealant: ASTM C 1311, single-component, solvent-release butyl rubber sealant; polyisobutylene plasticized; heavy bodied for expansion joints with limited movement.
- J. Asphalt Roofing Cement: ASTM D 4586/D 4586M, asbestos free, of consistency required for application.

2.11 GENERAL FINISH REQUIREMENTS

- A. Comply with NAAMM's "Metal Finishes Manual for Architectural and Metal Products" for recommendations for applying and designating finishes.
- B. Appearance of Finished Work: Noticeable variations in same piece are not acceptable. Variations in appearance of adjoining components are acceptable if they are within the range of approved Samples and are assembled or installed to minimize contrast.

PART 3 - EXECUTION

3.1 EXAMINATION

- A. Examine substrates, areas, and conditions, with Installer present, to verify actual locations, dimensions, and other conditions affecting performance of the Work.

- B. Verify that substrate is sound, dry, smooth, clean, sloped for drainage, and securely anchored.
- C. Verify dimensions of roof openings for roof accessories.
- D. Proceed with installation only after unsatisfactory conditions have been corrected.

3.2 INSTALLATION

- A. General: Install roof accessories according to manufacturer's written instructions.
 - 1. Install roof accessories level; plumb; true to line and elevation; and without warping, jogs in alignment, buckling, or tool marks.
 - 2. Anchor roof accessories securely in place so they are capable of resisting indicated loads.
 - 3. Use fasteners, separators, sealants, and other miscellaneous items as required to complete installation of roof accessories and fit them to substrates.
 - 4. Install roof accessories to resist exposure to weather without failing, rattling, leaking, or loosening of fasteners and seals.
- B. Metal Protection: Protect metals against galvanic action by separating dissimilar metals from contact with each other or with corrosive substrates by painting contact surfaces with bituminous coating or by other permanent separation as recommended by manufacturer.
 - 1. Coat concealed side of uncoated aluminum roof accessories with bituminous coating where in contact with wood, ferrous metal, or cementitious construction.
 - 2. Underlayment: Where installing roof accessories directly on cementitious or wood substrates, install a course of underlayment and cover with manufacturer's recommended slip sheet.
 - 3. Bed flanges in thick coat of asphalt roofing cement where required by manufacturers of roof accessories for waterproof performance.
- C. Roof Curb Installation: Install each roof curb so top surface is level.
- D. Equipment Support Installation: Install equipment supports so top surfaces are level with each other.
- E. Roof-Hatch Installation:
 - 1. Verify that roof hatch operates properly. Clean, lubricate, and adjust operating mechanism and hardware.
 - 2. Attach safety railing system to roof-hatch curb.
 - 3. Attach ladder-assist post according to manufacturer's written instructions.
- F. Heat and Smoke Vent Installation:
 - 1. Install heat and smoke vent so top perimeter surfaces are level.
 - 2. Install and test heat and smoke vents and their components for proper operation according to NFPA 204.

- G. Gravity Ventilator Installation: Verify that gravity ventilators operate properly and have unrestricted airflow. Clean, lubricate, and adjust operating mechanisms.
- H. Pipe Support Installation: Comply with MSS SP-58 and MSS SP-89. Install supports and attachments as required to properly support piping. Arrange for grouping of parallel runs of horizontal piping, and support together.
 - 1. Pipes of Various Sizes: Space supports for smallest pipe size or install intermediate supports for smaller diameter pipes as specified for individual pipe hangers.
- I. Preformed Flashing-Sleeve and Flashing Pipe Portal Installation: Secure flashing sleeve to roof membrane according to flashing-sleeve manufacturer's written instructions; flash sleeve flange to surrounding roof membrane according to roof membrane manufacturer's instructions.
- J. Security Grilles: Weld bar intersections and, using tamper-resistant bolts, attach the ends of bars to structural frame or primary curb walls.
- K. Roof Walkway Installation:
 - 1. Verify that locations of access and servicing points for roof-mounted equipment are served by locations of roof walkways.
 - 2. Remove ballast from top surface of low-slope roofing at locations of contact with roof-walkway supports.
 - 3. Install roof walkway support pads prior to placement of roof walkway support stands onto low-slope roofing.
 - 4. Redistribute removed ballast after installation of support pads.
- L. Seal joints with elastomeric sealant as required by roof accessory manufacturer.

3.3 REPAIR AND CLEANING

- A. Galvanized Surfaces: Clean field welds, bolted connections, and abraded areas and repair galvanizing according to ASTM A 780/A 780M.
- B. Touch up factory-primed surfaces with compatible primer ready for field painting according to Section 099113 "Exterior Painting."
- C. Clean exposed surfaces according to manufacturer's written instructions.
- D. Clean off excess sealants.
- E. Replace roof accessories that have been damaged or that cannot be successfully repaired by finish touchup or similar minor repair procedures.

END OF SECTION

SECTION 07 81 00 - APPLIED FIREPROOFING

PART 1 - GENERAL

1.1 RELATED DOCUMENTS

- A. Drawings and general provisions of the Contract, including General and Supplementary Conditions and Division 01 Specification Sections, apply to this Section.

1.2 SUMMARY

- A. Section includes sprayed fire-resistive materials.
- B. Related Requirements:
 - 1. Section 078123 "Intumescent Fireproofing" for mastic and intumescent fire-resistive coatings.
 - 2. Section 099646 "Intumescent Painting" for intumescent paints that are fire retarding but not fire resistive.

1.3 DEFINITIONS

- A. SFRM: Sprayed fire-resistive materials.

1.4 PREINSTALLATION MEETINGS

- A. Preinstallation Conference: Conduct conference at Project site.
 - 1. Review products, design ratings, restrained and unrestrained conditions, densities, thicknesses, bond strengths, and other performance requirements.

1.5 ACTION SUBMITTALS

- A. Product Data: For each type of product.
- B. Shop Drawings: Framing plans or schedules, or both, indicating the following:
 - 1. Extent of fireproofing for each construction and fire-resistance rating.
 - 2. Applicable fire-resistance design designations of a qualified testing and inspecting agency acceptable to authorities having jurisdiction.
 - 3. Minimum fireproofing thicknesses needed to achieve required fire-resistance rating of each structural component and assembly.
 - 4. Treatment of fireproofing after application.
- C. Samples: For each exposed product and for each color and texture specified, in manufacturer's standard dimensions in size.

1.6 INFORMATIONAL SUBMITTALS

- A. Qualification Data: For Installer.
- B. Product Certificates: For each type of fireproofing.
- C. Evaluation Reports: For fireproofing, from ICC-ES.
- D. Preconstruction Test Reports: For fireproofing.
- E. Field quality-control reports.

1.7 QUALITY ASSURANCE

- A. Installer Qualifications: A firm or individual certified, licensed, or otherwise qualified by fireproofing manufacturer as experienced and with sufficient trained staff to install manufacturer's products according to specified requirements.

1.8 PRECONSTRUCTION TESTING

- A. Preconstruction Adhesion and Compatibility Testing: Test for compliance with requirements for specified performance and test methods.
 - 1. Bond Strength: Test for cohesive and adhesive strength according to ASTM E 736. Provide bond strength indicated in referenced fire-resistance design, but not less than minimum specified in Part 2.
 - 2. Density: Test for density according to ASTM E 605. Provide density indicated in referenced fire-resistance design, but not less than minimum specified in Part 2.
 - 3. Verify that manufacturer, through its own laboratory testing or field experience, attests that primers or coatings are compatible with fireproofing.
 - 4. Schedule sufficient time for testing and analyzing results to prevent delaying the Work.
 - 5. For materials failing tests, obtain applied-fireproofing manufacturer's written instructions for corrective measures including the use of specially formulated bonding agents or primers.

1.9 FIELD CONDITIONS

- A. Environmental Limitations: Do not apply fireproofing when ambient or substrate temperature is 44 deg F or lower unless temporary protection and heat are provided to maintain temperature at or above this level for 24 hours before, during, and for 24 hours after product application.
- B. Ventilation: Ventilate building spaces during and after application of fireproofing, providing complete air exchanges according to manufacturer's written instructions. Use natural means or, if they are inadequate, forced-air circulation until fireproofing dries thoroughly.

PART 2 - PRODUCTS

2.1 PERFORMANCE REQUIREMENTS

- A. Assemblies: Provide fireproofing, including auxiliary materials, according to requirements of each fire-resistance design and manufacturer's written instructions.
- B. Source Limitations: Obtain fireproofing from single source.
- C. Fire-Resistance Design: Indicated on Drawings, tested according to ASTM E 119 or UL 263; testing by a qualified testing agency. Identify products with appropriate markings of applicable testing agency.
 - 1. Steel members are to be considered unrestrained unless specifically noted otherwise.
- D. Asbestos: Provide products containing no detectable asbestos.

2.2 SPRAYED FIRE-RESISTIVE MATERIALS

- A. Sprayed Fire-Resistive Material UL P701: Manufacturer's standard, factory-mixed, lightweight, dry formulation, complying with indicated fire-resistance design, and mixed with water at Project site to form a slurry or mortar before conveyance and application.
 - 1. Manufacturers: Subject to compliance with requirements, provide products by one of the following:
 - a. Carboline Company; a subsidiary of RPM International.
 - b. Grace Construction Products; W.R. Grace & Co. -- Conn.
 - c. Isolatek International.
 - d. Pyrok, Inc.
 - e. Schundler Company (The).
 - f. Southwest Fireproofing Products Co.
 - 2. Application: Designated for exterior use by a qualified testing agency acceptable to authorities having jurisdiction.
 - 3. Bond Strength: Minimum 430-lbf/sq. ft. cohesive and adhesive strength based on field testing according to ASTM E 736.
 - 4. Density: Not less than density specified in the approved fire-resistance design, according to ASTM E 605.
 - 5. Thickness: As required for fire-resistance design indicated, measured according to requirements of fire-resistance design or ASTM E 605, whichever is thicker, but not less than 0.375 inch.
 - 6. Combustion Characteristics: ASTM E 136.
 - 7. Surface-Burning Characteristics: Comply with ASTM E 84; testing by a qualified testing agency. Identify products with appropriate markings of applicable testing agency.
 - a. Flame-Spread Index: 10 or less.
 - b. Smoke-Developed Index: 10 or less.

8. Compressive Strength: Minimum 100 lbf/sq. in. according to ASTM E 761.
9. Corrosion Resistance: No evidence of corrosion according to ASTM E 937.
10. Deflection: No cracking, spalling, or delamination according to ASTM E 759.
11. Effect of Impact on Bonding: No cracking, spalling, or delamination according to ASTM E 760.
12. Air Erosion: Maximum weight loss of 0.025 g/sq. ft. in 24 hours according to ASTM E 859.
13. Fungal Resistance: Treat products with manufacturer's standard antimicrobial formulation to result in no growth on specimens per ASTM G 21
14. Sound Absorption: NRC of 0.50 to 0.75 according to ASTM C 423 for Type A mounting according to ASTM E 795.
15. Finish: As selected by Architect from manufacturer's standard finishes
 - a. Color: As selected by Architect from manufacturer's full range.

2.3 AUXILIARY MATERIALS

- A. General: Provide auxiliary materials that are compatible with fireproofing and substrates and are approved by UL or another testing and inspecting agency acceptable to authorities having jurisdiction for use in fire-resistance designs indicated.
- B. Substrate Primers: Primers approved by fireproofing manufacturer and complying with one or both of the following requirements:
 1. Primer and substrate are identical to those tested in required fire-resistance design by UL or another testing and inspecting agency acceptable to authorities having jurisdiction.
 2. Primer's bond strength in required fire-resistance design complies with specified bond strength for fireproofing and with requirements in UL's "Fire Resistance Directory" or in the listings of another qualified testing agency acceptable to authorities having jurisdiction, based on a series of bond tests according to ASTM E 736.
- C. Bonding Agent: Product approved by fireproofing manufacturer and complying with requirements in UL's "Fire Resistance Directory" or in the listings of another qualified testing agency acceptable to authorities having jurisdiction.
- D. Metal Lath: Expanded metal lath fabricated from material of weight, configuration, and finish required, according to fire-resistance designs indicated and fireproofing manufacturer's written instructions. Include clips, lathing accessories, corner beads, and other anchorage devices required to attach lath to substrates and to receive fireproofing.
- E. Reinforcing Fabric: Glass- or carbon-fiber fabric of type, weight, and form required to comply with fire-resistance designs indicated; approved and provided by fireproofing manufacturer.
- F. Reinforcing Mesh: Metallic mesh reinforcement of type, weight, and form required to comply with fire-resistance design indicated; approved and provided by fireproofing manufacturer. Include pins and attachment.

- G. Sealer: Transparent-drying, water-dispersible, tinted protective coating recommended in writing by fireproofing manufacturer for each fire-resistance design.
- H. Topcoat: Suitable for application over applied fireproofing; of type recommended in writing by fireproofing manufacturer for each fire-resistance design.
 - 1. Cement-Based Topcoat: Factory-mixed, cementitious hard-coat formulation for trowel or spray application over SFRM.
 - 2. Water-Based Permeable Topcoat: Factory-mixed formulation for brush, roller, or spray application over applied SFRM. Provide application at a rate of 30 sq. ft./gal.

PART 3 - EXECUTION

3.1 EXAMINATION

- A. Examine substrates, areas, and conditions, with Installer present, for compliance with requirements for substrates and other conditions affecting performance of the Work and according to each fire-resistance design.
 - 1. Verify that substrates are free of dirt, oil, grease, release agents, rolling compounds, mill scale, loose scale, incompatible primers, paints, and encapsulants, or other foreign substances capable of impairing bond of fireproofing with substrates under conditions of normal use or fire exposure.
 - 2. Verify that objects penetrating fireproofing, including clips, hangers, support sleeves, and similar items, are securely attached to substrates.
 - 3. Verify that substrates receiving fireproofing are not obstructed by ducts, piping, equipment, or other suspended construction that will interfere with fireproofing application.
- B. Verify that concrete work on steel deck is complete before beginning fireproofing work.
- C. Verify that roof construction, installation of rooftop HVAC equipment, and other related work are complete before beginning fireproofing work.
- D. Conduct tests according to fireproofing manufacturer's written instructions to verify that substrates are free of substances capable of interfering with bond.
- E. Prepare written report, endorsed by Installer, listing conditions detrimental to performance of the Work.
- F. Proceed with installation only after unsatisfactory conditions have been corrected.

3.2 PREPARATION

- A. Cover other work subject to damage from fallout or overspray of fireproofing materials during application.
- B. Clean substrates of substances that could impair bond of fireproofing.

- C. Prime substrates where included in fire-resistance design and where recommended in writing by fireproofing manufacturer unless compatible shop primer has been applied and is in satisfactory condition to receive fireproofing.
- D. For applications visible on completion of Project, repair substrates to remove surface imperfections that could affect uniformity of texture and thickness in finished surface of fireproofing. Remove minor projections and fill voids that would telegraph through fire-resistive products after application.

3.3 APPLICATION

- A. Construct fireproofing assemblies that are identical to fire-resistance design indicated and products as specified, tested, and substantiated by test reports; for thickness, primers, sealers, topcoats, finishing, and other materials and procedures affecting fireproofing work.
- B. Comply with fireproofing manufacturer's written instructions for mixing materials, application procedures, and types of equipment used to mix, convey, and apply fireproofing; as applicable to particular conditions of installation and as required to achieve fire-resistance ratings indicated.
- C. Coordinate application of fireproofing with other construction to minimize need to cut or remove fireproofing.
 - 1. Do not begin applying fireproofing until clips, hangers, supports, sleeves, and other items penetrating fireproofing are in place.
 - 2. Defer installing ducts, piping, and other items that would interfere with applying fireproofing until application of fireproofing is completed.
- D. Metal Decks:
 - 1. Do not apply fireproofing to underside of metal deck substrates until concrete topping, if any, is completed.
 - 2. Do not apply fireproofing to underside of metal roof deck until roofing is completed; prohibit roof traffic during application and drying of fireproofing.
- E. Install auxiliary materials as required, as detailed, and according to fire-resistance design and fireproofing manufacturer's written instructions for conditions of exposure and intended use. For auxiliary materials, use attachment and anchorage devices of type recommended in writing by fireproofing manufacturer.
- F. Spray apply fireproofing to maximum extent possible. After the spraying operation in each area, complete the coverage by trowel application or other placement method recommended in writing by fireproofing manufacturer.
- G. Extend fireproofing in full thickness over entire area of each substrate to be protected.
- H. Install body of fireproofing in a single course unless otherwise recommended in writing by fireproofing manufacturer.

- I. For applications over encapsulant materials, including lockdown (post-removal) encapsulants, apply fireproofing that differs in color from that of encapsulant over which it is applied.
- J. Where sealers are used, apply products that are tinted to differentiate them from fireproofing over which they are applied.
- K. Provide a uniform finish complying with description indicated for each type of fireproofing material and matching finish approved for required mockups.
- L. Cure fireproofing according to fireproofing manufacturer's written instructions.
- M. Do not install enclosing or concealing construction until after fireproofing has been applied, inspected, and tested and corrections have been made to deficient applications.
- N. Finishes: Where indicated, apply fireproofing to produce the following finishes:
 - 1. Manufacturer's Standard Finishes: Finish according to manufacturer's written instructions for each finish selected.
 - 2. Spray-Textured Finish: Finish left as spray applied with no further treatment.
 - 3. Rolled, Spray-Textured Finish: Even finish produced by rolling spray-applied finish with a damp paint roller to remove drippings and excessive roughness.
 - 4. Skip-Troweled Finish: Even leveled surface produced by troweling spray-applied finish to smooth out the texture and neaten edges.
 - 5. Skip-Troweled Finish with Corner Beads: Even, leveled surface produced by troweling spray-applied finish to smooth out the texture, eliminate surface markings, and square off edges.

3.4 FIELD QUALITY CONTROL

- A. Special Inspections: Engage a qualified special inspector to perform the following special inspections:
 - 1. Test and inspect as required by the IBC, Subsection 1705.13, "Sprayed Fire-Resistant Materials."
- B. Perform the tests and inspections of completed Work in successive stages. Do not proceed with application of fireproofing for the next area until test results for previously completed applications of fireproofing show compliance with requirements. Tested values must equal or exceed values as specified and as indicated and required for approved fire-resistance design.
- C. Fireproofing will be considered defective if it does not pass tests and inspections.
 - 1. Remove and replace fireproofing that does not pass tests and inspections, and retest.
 - 2. Apply additional fireproofing, per manufacturer's written instructions, where test results indicate insufficient thickness, and retest.
- D. Prepare test and inspection reports.

3.5 CLEANING, PROTECTING, AND REPAIRING

- A. Cleaning: Immediately after completing spraying operations in each containable area of Project, remove material overspray and fallout from surfaces of other construction and clean exposed surfaces to remove evidence of soiling.
- B. Protect fireproofing, according to advice of manufacturer and Installer, from damage resulting from construction operations or other causes, so fireproofing is without damage or deterioration at time of Substantial Completion.
- C. As installation of other construction proceeds, inspect fireproofing and repair damaged areas and fireproofing removed due to work of other trades.
- D. Repair fireproofing damaged by other work before concealing it with other construction.
- E. Repair fireproofing by reapplying it using same method as original installation or using manufacturer's recommended trowel-applied product.

3.7 UL ASSEMBLIES & PENETRATIONS

- A. Please see following pages for UL assembly details referenced in drawings.

END OF SECTION

SECTION 07 84 00 – FIRESTOPPING

Part 1 - GENERAL

1.1 Summary

- A. Furnish labor, materials, tools, equipment, and services for Firestopping, in accordance with provisions of Contract Documents.
- B. Completely coordinate with work of other trades.

1.2 Quality Assurance

- A. Installer Qualifications:
 - 1. Certified, licensed or approved by firestopping manufacturer, trained to install firestop products per specified requirements.
 - 2. Licensed by State or local authority, where applicable.
 - 3. Shown to have successfully completed not less than five (5) comparable scale projects.
- B. Provide firestop systems in compliance with following requirements:
 - 1. Obtain firestop system for each type of penetration and construction condition from a single firestop systems manufacturer.
 - 2. Firestop products and systems shall bear classification marking of qualified testing and inspection agency.
 - 3. Firestopping tests, performed by qualified, testing and inspection agency.
 - a. UL or other agency, performing testing and follow-up inspection services for firestop systems, acceptable to local authorities having jurisdiction.
 - 4. Existing applications for which no tested and listed classified system is available through a manufacturer:
 - a. Provide Engineering Judgment or Equivalent Fire Resistance Rated Assembly (EFRR) for submittal derived from similar UL system designs or other tests approved by local authorities having jurisdiction, prior to installation.
 - b. Engineering judgment drawings must follow requirements set forth by International Firestop Council.
 - 5. Inspect applied firestopping systems in accordance with International Building Code (IBC) Chapter 17.
 - a. Inspections shall be performed by an FMG 4991 Approved Specialty Contractor/UL Qualified Firestop Contractor and/or ASTM E2174 and ASTM E2393.
 - b. See Section 01 45 23.
 - 6. FM Approved in accordance with FM Standard 4991 – Approval of Firestop Contractors.
 - 7. UL Qualified Firestop Contractor.
- C. Underwriters Laboratories, Inc. (UL):
 - 1. UL 263, Fire Tests of Building Construction and Materials
 - 2. UL 723, Surface Burning Characteristics of Building Materials
 - 3. UL 1479, Fire Tests of Through Penetration Firestops
 - 4. UL 2079, Tests for Fire Resistance of Building Joint Systems
- D. ASTM International (ASTM):
 - 1. ASTM E84 Surface Burning Characteristics of Building Materials
 - 2. ASTM E119 Fire Tests of Building Construction and Materials

3. ASTM E136 Test Method for Behavior of Materials in a Vertical Tube Furnace at 750F
 4. ASTM E814 Fire Tests of Through Penetration Fire Stops
 5. ASTM E1399 Cyclic Movement and Measuring the Minimum and Maximum Joint Widths of Architectural Joint Systems
 6. ASTM E1966 Test Method for Fire Resistive Joint Systems
 7. ASTM E2174 Standard Practice for On-site Inspection of Installed Fire Stops
 8. ASTM E2307 Standard Test Method for Determining the Fire Endurance of Perimeter Fire Barrier Systems Using the Intermediate-Scale, Multi Story Test Apparatus (ISMA)
 9. ASTM E2393 Standard Practice for On-site Inspection of Installed Fire Resistive Joint Systems and Perimeter Fire Barriers
 10. ASTM G21 Standard Practice for Determining Resistance of Synthetic Polymeric Materials to Fungi
- E. Building Code as locally adopted and amended.
- F. Underwriters Laboratories (UL) Fire Resistance Directory:
1. Through Penetration Firestop Systems (XHEZ).
 2. Joint Systems (XHBN).
 3. Fill, Void or Cavity Materials (XHHW).
 4. Firestop Devices (XHJI).
 5. Forming Materials (XHKU).
 6. Wall Opening Protective Materials (CLIV).
- G. National Fire Protection Association (NFPA):
1. NFPA 70: National Electrical Code
 2. NFPA 101: Life Safety Code
 3. NFPA 22: Standard for High Challenge Fire Walls, Fire Walls, and Fire Barrier Walls
 4. NFPA 251: Fire Tests of Building Construction and Materials
- H. Firestop Contractors International Association (FCIA): MOP – FCIA Firestop Manual of Practice
- I. International Firestop Council (IFC):
1. Recommended IFC Guidelines for Evaluating Firestop Engineering Judgments, latest revision.
 2. Inspectors Field Pocket Guide, latest edition.
- J. Identification Labels for Firestop Assemblies:
1. Follow guidelines set in Chapter 7 of International Building Code.
 2. Coordinate with Section 04 22 00 and Section 09 29 00.
 3. Label penetration on both sides of wall or slab.
 4. Label each penetration or group of similar penetrations with a permanent label marked with the following information:
 - a. UL system number.
 - b. Rating.
 - c. Products used.
 - d. Installation date.
 - e. Installer name.
 - f. Penetration reference number unique to each location.
- K. Pipe insulation shall not be removed, cut away or otherwise interrupted through wall or floor openings.
1. Provide products appropriately tested for the thickness and type of insulation utilized.
- L. Cabling where frequent cable moves, add-ons, and changes are likely to occur in future:

1. Where cable trays are used:
 - a. Utilize re-enterable products (e.g. removable intumescent pillows) specifically designed for retrofit.
 2. Where cable trays are not used:
 - a. Utilize fire-rated cable pathway devices.
 - b. Where not practical, re-enterable products designed for retrofit may be used.
- M. Protect penetrations passing through fire-resistance rated floor-ceiling assemblies contained within chase wall assemblies with products tested by being fully exposed to fire outside of chase wall.
1. Identify systems within UL Fire Resistance Directory with the words: Chase Wall Optional.
- N. Fire Resistive Joint Sealant:
1. Provide flexible fire-resistive joint sealants to accommodate normal and thermal building movement without seal damage.
 2. Provide fire-resistive joint sealants designed to accommodate a specific range of movement.
 - a. Test in accordance with cyclic movement test criteria as outlined in: ASTM E1399, ASTM E1966 or UL 2079.
 3. Provide fire-resistive joint systems subjected to an air leakage test.
 - a. Conduct in accordance with UL 2079, with published L-Ratings for ambient and elevated temperatures, as evidence of ability of fire-resistive joint system to restrict movement of smoke.
 4. Coordinate firestopping with acoustical sealant requirements in Section 07 92 16.
- O. Subject smoke wall containment systems to air leakage test.
1. Conduct in accordance with UL 1479, with published L-Ratings for ambient and elevated temperatures, as evidence of ability of fire-resistive joint system to restrict movement of smoke.
- P. System Description:
1. Through Penetration Firestop Systems for protection of penetrations through following fire-resistance rated assemblies, including both blank openings and openings containing penetrating items:
 - a. Roof assemblies.
 - b. Floor assemblies.
 - c. Wall and partition assemblies.
 - d. Fire-rated smoke barrier assemblies.
 - e. Existing, fire and smoke-rated assemblies.
 - f. Construction enclosing compartmentalized areas.
 2. Fire Resistive Joint Assemblies for linear voids where fire-rated floor, roof, or wall assemblies abut one another, including following types of joints:
 - a. Top and bottom of wall interface with overhead roof or floor structure:
 - 1) Coordinate with acoustical sealant specified in Section 09 29 00.
 - 2) Select products to maintain acoustical, smoke and fire ratings indicated.
 - b. Non-Fire Rated Expansion Joints: Specified in Section 07 95 13.
 - c. Fire Rated Expansion Joints: Specified in Section 07 95 13.

1.3 SUBMITTALS

- A. Product Data: Manufacturer's standard information indicating certification of products proposed for use on project.
- B. Project Information: UL reports with illustration of systems, system numbers, temperature ratings, and products proposed for use on project.

- C. Contract Closeout Information:
 - 1. Warranty.
 - 2. Electronic file of project firestopping documentation.

1.4 Warranty

- A. Written five (5) year warranty guaranteeing quality of installation and meeting requirements of manufacturer's written instructions and tested systems.

Part 2 - PRODUCTS

2.1 Acceptable manufacturers

- A. Firestopping:
 - 1. Base:
 - a. Hilti - Firestopping Products.
- B. Forming Materials:
 - 1. Base:
 - a. Hilti - Firestopping Products.
- C. Other manufacturers desiring approval, comply with Section 00 26 00.
 - 1. See systems Volume 2 of UL Building Materials Directory.

2.2 MATERIALS

- A. Through Penetration Firestop Systems:
 - 1. VOC content not to exceed 250 g/L
 - 2. Base Products:
 - a. FS-ONE Intumescent Firestop Sealant.
 - b. CP 604 Self-leveling Firestop Sealant.
 - c. CP 620 Fire Foam.
 - d. CP 606 Flexible Firestop Sealant.
 - e. CP 601S Elastomeric Firestop Sealant.
- B. Fire-resistive Joints:
 - 1. VOC content not to exceed 250 g/L
 - 2. Base Products:
 - a. CFS-SP WB Firestop Joint Spray.
 - b. CP 601S Elastomeric Firestop Sealant.
 - c. CP 606 Flexible Firestop Sealant.
 - d. CP 604 Self-leveling Firestop Sealant.
- C. Firestop Devices:
 - 1. Factory-assembled collars lined with intumescent material sized to fit specific outside diameter of penetrating item.
 - 2. Base Products:
 - a. CP 680-P Cast-in-Place Firestop Device.
 - b. CP 680-M Cast-in-Place Firestop Device.
 - c. CP 681 Tub Box Kit.
 - d. CFS-DID Firestop Device.
- D. Intumescent Pads, Wall Opening Protective Materials:
 - 1. Intumescent, non-curing pads or inserts for protection of electrical panels, switch and receptacle boxes, medical gas outlets and valve boxes and other items recessed in face of fire rated walls.
 - 2. Base Product:

- a. CFS-P PA Firestop Putty Pad.
 - b. CP 617 Firestop Putty Pad.
 - c. Hilti Biox Insert.
- E. Fire-rated Cable Pathways:
1. Usage:
 - a. Cables passing through fire-rated floors or walls shall pass through fire-rated cable pathway devices made from an intumescent material that adjusts automatically to cable additions or subtractions.
 2. Product description and requirements:
 - a. Pathway device modules comprised of steel raceway and intumescent pads with adjustable smoke seal sleeve.
 - b. F-Rating equal to the rating of barrier the device penetrates.
 - c. Pathway devices shall be capable of allowing a 0 to 100 percent fill of cables.
 - d. Size to accommodate quantity and size of electrical wires and data cables indicated plus 100 percent expansion.
 - e. Provide wire devices with steel wall plates allowing for single or multiple devices ganged together without requiring additional wall structure framing.
 3. Base product:
 - a. CP 653 Speed Sleeve.
 - 1) Use in conjunction with CFS-SL GP when more than one device is required.
 - b. CFS-CC Firestop Cable Collar.
- F. Firestop Putty:
1. Intumescent, non-hardening, water resistant putties containing no solvents, inorganic fibers or silicone compounds.
 2. Firestop putty shall be provided and installed at, but not limited to, the gap between wire, cabling, or both, exiting an open end of conduit, where conduit penetrates one or both sides of a smoke or fire rated wall assembly.
 3. Base products:
 - a. CP 618 Firestop Putty Stick.
 - b. CFS-PL Firestop Plug.
- G. Wrap Strips:
1. Single component intumescent elastomeric strips faced on both sides with a plastic film:
 2. Base Products:
 - a. CP 643N Firestop Collar.
 - b. CP 644 Firestop Collar.
 - c. CP 648E/648S Wrap Strips.
- H. Firestop Blocks:
1. Re-enterable, non-curing, intumescent flexible block.
 2. Base products:
 - a. CFS-BL Fire Block.
 - b. CFS-PL Firestop Plug.
- I. Mortar:
1. Portland cement based dry-mix product formulated for mixing with water at Project site to form a non-shrinking, water-resistant, homogenous mortar.
 2. Base product:
 - a. CP 637 Firestop Mortar.
- J. Silicone Sealants:
1. Moisture curing, single component, silicone elastomeric sealant for horizontal surfaces pourable or nonsag or vertical surface nonsag.

2. Base product:
 - a. CP 601S Elastomeric Firestop Sealant.
 - b. CP 604 Self Leveling Silicone Firestop Sealant.
 - c. CFS-SIL SL Self Leveling Silicone Firestop Sealant.
- K. Pre-formed mineral wool:
 1. CP 767 Speed Strips
 2. CP 777 Speed Plugs
- L. Fire Sealant:
 1. Single component latex or acrylic formulations that upon cure do not re-emulsify during exposure to moisture.
 - a. CP 601S Elastic Firestop Sealant.
 - b. CP 606 Fire Resistant Joint Filler.
 - c. CP 672 Firestop Joint Spray.
 - d. CFS-SP WB Firestop Joint Spray.
 2. VOC content of sealants shall be no greater than 250 g/L.
 3. VOC content of sealants shall be no greater than 250 g/L.
 4. Adhesives and sealants shall contain no carcinogen or reproductive toxicant components present at more than 1 percent of total mass of the product as defined in the California Office of Environmental Health Hazard Assessment's (OEHHA) list entitled, Chemicals Known to the State to Cause Cancer, or the Reproductive Toxicity, Safe Drinking Water and Toxic Enforcement Act of 1986 (Proposition 65).
- M. Composite Sheet:
 1. Non-curing, re-penetrable material.
 2. Base Products:
 - a. CP 675T Firestop Board.
 - b. CFS-BL FireBlock.
- N. Forming Materials:
 1. Materials listed as components in laboratory-approved designs.
 2. Mineral Wool:
 - a. Base Product: CP 767 Speed Strip
 - b. Similar product specifically named as components in laboratory-approved designs.
- O. Perimeter Fire Containment: Specified in Section 07 84 53.
- P. Acoustical Sealant: Specified in Section 07 92 16.

2.3 THROUGH PENETRATION FIRESTOP SYSTEMS

- A. General:
 1. Schedules below identify requirements for acceptable through penetration firestop systems based on barrier type, fire-resistive rating, and penetrant type. Each system must comply with building code and fire code as locally adopted and amended.
 2. Requirements for single-membrane penetrations and through penetration firestops are identical. Unless otherwise noted, penetrants which pass through a single membrane, shall be treated the same as if it passed through the entire fire-resistive assembly.
 3. Select each firestop system based on actual field conditions, including penetration type, shape, size, quantities and physical position within opening.
 4. Refer to Plans for indication of the required ratings of fire-resistive wall, floor, and roof assemblies.

5. Indicated ratings are minimum and may be exceeded.
6. Firestop Assemblies at Fire-Rated Walls:
 - a. The minimum Fire (F) Rating for Firestop assemblies in walls shall equal that of the wall, but not less than 1-HR.
 - b. The minimum Temperature (T) Rating of Firestop assemblies in walls may equal zero.
 - c. Smoke Barrier: In addition to (F) Rating, (L) Rating of maximum 5 CFM per SF.
 - d. Non-rated walls and Smoke-Partitions with no fire-resistive requirement: Assembly with (L) rating.
7. Firestop assemblies at fire-rated floors and roofs:
 - a. Minimum Fire (F) and Temperature (T) Ratings of Firestop assemblies used in floors or roof shall equal hourly rating of floor or roof being penetrated, but not less than 1-HR.
 - 1) Exception 1: The T-rating may equal zero when portion of penetration, above or below floor, is contained within a wall.
 - 2) Exception 2: Firestops are not required for floor penetrations within a 2-hour rated shaft enclosure.
- B. Voids in wall with no penetrations:
 1. Fill with approved through penetration firestopping system.
 2. Contractor's option: Patch void in wall with like construction.
- C. Penetrating Ducts with Dampers:
 1. Utilize only firestop materials which are included in damper's classification.
 2. Do not install firestop systems that hamper performance of fire dampers.
- D. Cable Trays and similar devices:
 1. Provide re-enterable products specifically designed for removal and re-installation at openings within walls and floors designed to accommodate voice, data and video cabling.
- E. Electrical panels and devices, medical gas outlets and valve boxes, film illuminators, and other items recessed in to face of rated walls:
 1. Where electrical devices are placed on opposite sides of wall, and are less than 24 IN apart measured horizontally, install intumescent pads over back of devices in approved manner or maintain continuity of rated barrier within wall cavity surrounding recessed item.

2.4 FIRE-RESISTIVE JOINT ASSEMBLIES – GENERAL

- A. General:
 1. Where joint will be exposed to elements, fire-resistive joint sealant must be approved by manufacturer for use in exterior applications and shall comply with ASTM C920.
- B. Head-of-Wall Assemblies:
 1. General:
 - a. Use at top of fire-rated and smoke barrier walls and partitions where they abut floor and roof structures above.
 - b. Select systems with D designation, rated for dynamic movement capability.
 - c. Select systems that can accommodate deflection of structure above.
 - d. Maximum Leakage for Fire-resistive Joints in Smoke Barriers: 5 CFM or less per linear foot as tested in accordance with UL 2079.
 - e. Seal non-fire-rated sound-control walls and smoke partitions with acoustical sealant as specified in Section 07 92 16.
 2. Minimum F and T ratings:

- a. The minimum fire rating for firestop assemblies in walls shall equal that of wall, but not less than 1-HR.
 - b. The minimum temperature rating of firestop assemblies in walls may equal zero.
3. Acceptable Systems:
- a. Metal stud and drywall partitions: Select system from UL HW-D-0000 Series.
 - b. Concrete and Masonry Walls: Select system from UL HW-D-1000 Series.

Part 3 - EXECUTION

3.1 PREPARATION

- A. Examine areas and conditions under which work is to be performed and identify conditions detrimental to proper or timely completion.
- B. Surfaces to which firestop materials will be applied shall be free of dirt, grease, oil, scale, laitance, rust, release agents, water repellents, and any other substances that may inhibit optimum adhesion.
- C. Provide masking and temporary covering to prevent soiling of adjacent surfaces by firestopping materials.
- D. Do not proceed until unsatisfactory conditions have been corrected.

3.2 Installation

- A. General:
 1. Install firestop systems in accordance with manufacturer's instructions and conditions of testing and classification as specified in UL or other acceptable third-party testing agency listing.
 2. Penetrations through fire-resistive floor assemblies shall be sealed with firestop system providing minimum Class 1 W-rating as tested in accordance with UL 1479 and ensure air and water resistant seal.
 3. Protect materials from damage on surfaces subjected to traffic.
- B. Identification Labels:
 1. Identify each firestop assembly as defined in Quality Assurance.
 2. Do not locate identification labels, tags, or both, on finished surfaces or where exposed to view by public.

3.3 FIELD QUALITY CONTROL

- A. Owner shall engage a qualified independent inspection agency to inspect firestop systems in accordance with ASTM E2174, Standard Practice for On-site Inspection of Installed Fire Stops, and ASTM E2393, Standard Practice for On-Site Inspection of Installed Fire Resistive Joint Systems and Perimeter Fire Barriers.
- B. Construct mock-up on-site to include typical through penetration and fire-resistive joint applications for project.
- C. Maintain areas of work accessible until inspection by authorities having jurisdiction.
- D. Where deficiencies are found, repair or replace assemblies to comply with requirements.

3.4 ADJUSTING AND CLEANING

- A. Remove equipment, materials and debris, leaving area in undamaged, clean condition.

- B. Clean surfaces adjacent to sealed openings free of excess materials and soiling as work progresses.
- C. Perform patching and repair of firestopping systems damaged by other trades.

END OF SECTION

UL PRODUCT CATEGORY

Assembly Usage Disclaimer

XHBN - Joint Systems

See General Information for Joint Systems

System No. HW-D-0036

September 01, 2016

Assembly Rating - 1 and 2 Hr (See Item 2)

Nominal Joint Width - 3/4 In.

Class II Movement Capabilities - 33% Compression or Extension

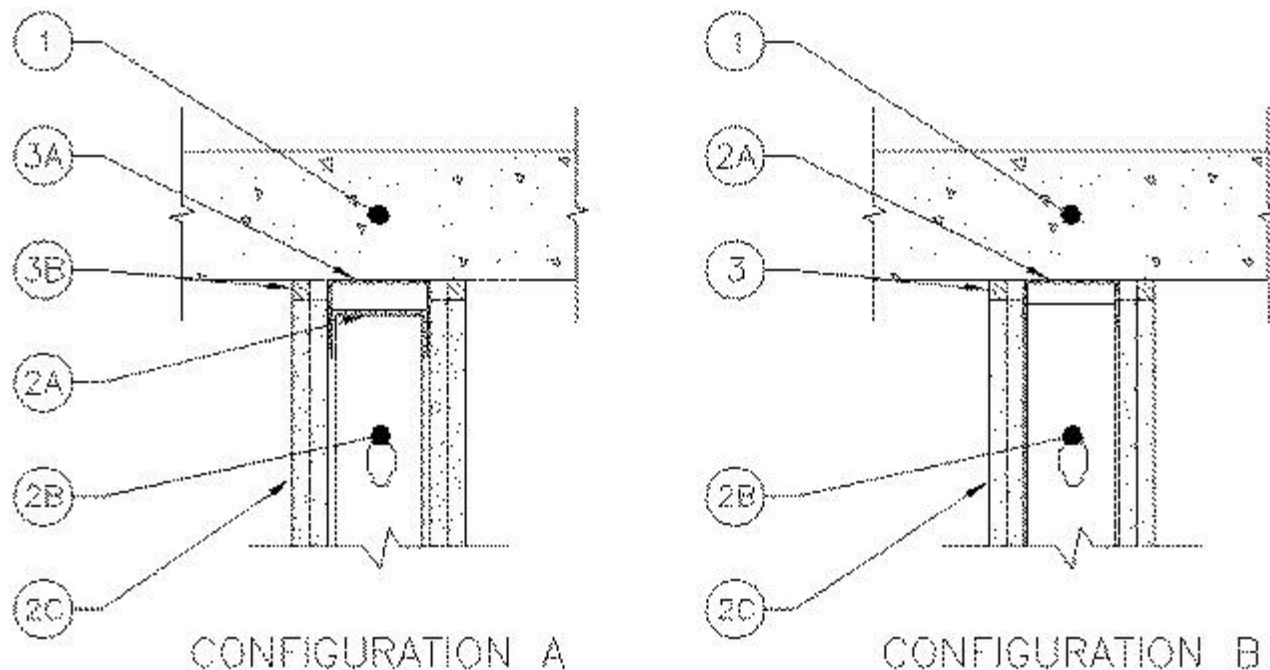

1. Floor Assembly — Min 4-1/2 in. (114 mm) thick reinforced lightweight or normal weight (100-150 pcf or 1600-2400 kg/m³) concrete. Floor may also be constructed of any min 6 in. (152 mm) thick UL Classified hollow core **Precast Concrete Units***.

See **Precast Concrete Units** (CFTV) category in the Fire Resistance Directory for names of manufacturers.

CONFIGURATION A

2. Wall Assembly — The 1 or 2 hr fire rated gypsum board/steel stud wall assembly shall be constructed of the materials and in the manner described in the individual U400 or V400 Series Wall and Partition Design in the UL Fire Resistance Directory and shall include the following construction features:

A. Steel Floor And Ceiling Runners — Floor and Ceiling runners of wall assembly shall consist of galv steel channels sized to accommodate steel studs (Item 2B). Ceiling runner to be installed within the deflection channel such that a 1 in. (25 mm) gap is maintained between the top of ceiling runner and top of deflection channel. Deflection channel is secured to floor with steel masonry anchors spaced a max of 24 in. (610 mm) OC.

B. Studs — Steel studs to be min 3-5/8 in. (92 mm) wide. Studs cut 1/2 to 3/4 in. (13 to 19 mm) less in length than assembly height. Studs attached to ceiling runner with sheet metal screws a min of 1/2 in. (13 mm) below bottom of deflection channel. Stud spacing not to exceed 24 in. (610 mm) OC.

C. Gypsum Board* — Gypsum board sheets to be installed to a min total thickness of 5/8 or 1-1/4 in. (16 or 32 mm) on each side of the wall for a 1 or 2 hr fire rated assemblies, respectively. Wall to be constructed as specified in the individual Wall and Partition Design in the UL Fire Resistance Directory, except that a nom 3/4 in. (19 mm) gap shall be maintained between the top of the gypsum board and the lower surface of the floor. The screws attaching the wallboard to studs at the top of the wall shall be located 1 in. (25 mm) below the bottom of the U-shaped deflection channel (Item 3A).

The hourly fire rating of the joint system is dependent on the hourly fire rating of the wall.

3. Joint System — **Max separation between bottom of floor and top of wall is 3/4 in. (19 mm). The joint system is designed to accommodate a max 33 percent compression or extension from its installed width.** The joint system consists of a deflection channel and a fill material, as follows:

A. Deflection Channel — A nom 3-5/8 in. (92 mm) wide by min 2 in. (51 mm) deep min 24 gauge (or heavier) steel U-shaped channel. Deflection channel secured to floor assembly with steel fasteners, spaced max 24 in. (610 mm) OC. The ceiling runner (Item 2A) is installed within the deflection channel to maintain a 1 in. (25 mm) gap between the top of the ceiling runner and the top of the deflection channel. The ceiling runner is not fastened to the deflection channel.

B. Fill, Void or Cavity Material* — Sealant — Min 5/8 in. (16 mm) thickness of fill material installed on each side of the wall between the top of the gypsum board and the bottom of floor, flush with each surface of gypsum board.

PASSIVE FIRE PROTECTION PARTNERS — 4100NS, 4800DW or 3600EX

CONFIGURATION B

2. Wall Assembly — The 1 or 2 hr fire rated gypsum board/steel stud wall assembly shall be constructed of the materials and in the manner described in the individual U400 or V400 Series Wall and Partition Design in the UL Fire Resistance Directory and shall include the following construction features:

A. Steel Floor and Ceiling Runners — Floor and Ceiling runners of wall assembly shall consist of galv steel channels sized to accommodate steel studs (Item 2B). Ceiling runner is secured to concrete floor slab with steel masonry anchors spaced max 24 in. (610 mm) OC.

A1. Light Gauge Framing* — Slotted Ceiling Runner — As an alternate to the ceiling runner in Item 2A, slotted ceiling runner to consist of galv steel channel with slotted flanges sized to accommodate steel studs (Item 2B). Slotted ceiling runner is secured to concrete floor slab with steel masonry anchors spaced max 24 in. (610 mm) OC.

BRADY CONSTRUCTION INNOVATIONS INC, DBA SLIPTRACK SYSTEMS — SLP-TRK

CALIFORNIA EXPANDED METAL PRODUCTS CO — CST

CLARKDIETRICH BUILDING SYSTEMS — Type SLT, SLT-H

MARINOWARE, DIV OF WARE INDUSTRIES INC — Type SLT

METAL-LITE INC — The System

RAM SALES L L C — RAM Slotted Track

SCAFCO STEEL STUD MANUFACTURING CO

STEELER INC — Steeler Slotted Ceiling Runner

TELLING INDUSTRIES L L C — True-Action Deflection Track

A2. Light Gauge Framing* — Vertical Deflection Ceiling Runner — As an alternate to the ceiling runner in Items 2A, 2A1 or 2A2, vertical deflection ceiling runner to consist of galv steel channel with slotted vertical deflection clips mechanically fastened within runner.

Slotted clips, provided with step bushings, for permanent fastening of steel studs. Vertical deflection ceiling runner secured to concrete floor slab with steel masonry anchors spaced max 24 in. (610 mm) OC.
THE STEEL NETWORK INC — VertiTrack VTD362, VTD400, VTD600 and VTD800

A3. Light Gauge Framing* — Notched Ceiling Runner — As an alternate to the ceiling runners in Items 2A through 2A3, notched ceiling runners to consist of C-shaped galv steel channel with notched return flanges sized to accommodate steel studs (Item 2B). Notched ceiling runner secured to concrete floor slab with steel masonry anchors spaced max 24 in. (610 mm) OC. When notched ceiling runner is used, deflection channel (Item 3A) shall not be used.
OLMAR SUPPLY INC — Type SCR

B. Studs — Steel studs to be min 3-5/8 in. (92 mm) wide. Studs cut 1/2 to 3/4 in. (13 to 19 mm) less in length than assembly height. Steel studs shall not be secured to ceiling runner. When slotted ceiling runner (Item 2A1) is used, steel studs secured to slotted ceiling runner with No. 8 by 1/2 in. (13 mm) long wafer head steel crews at mid-height of slot on each side of wall. When vertical deflection ceiling runner (Item 2A3) is used, steel studs secured to slotted vertical deflection clips, through bushings, with steel screws at mid-height of each slot. Stud spacing not to exceed 24 in. (610 mm) OC.

C. Gypsum Board* — Gypsum board sheets to be installed to a min total thickness of 5/8 or 1-1/4 in. (16 or 32 mm) on each side of the wall for a 1 or 2 hr fire rated assemblies, respectively. Wall to be constructed as specified in the individual Wall and Partition Design in the UL Fire Resistance Directory, except that a nom 3/4 in. (19 mm) gap shall be maintained between the top of the gypsum board and the lower surface of the floor. The screws attaching the gypsum board to studs at the top of the wall shall be located 1 in. (25 mm) below the bottom of the ceiling runner.

The hourly fire rating of the joint system is dependent on the hourly fire rating of the wall.

3. Fill, Void or Cavity Material* — Sealant — Max separation between bottom of floor and top of wall is 3/4 in. (19 mm). The joint system is designed to accommodate a max 33 percent compression or extension from its installed width. Min 5/8 in. (16 mm) thickness of fill material installed on each side of the wall between the top of the gypsum board and the bottom of floor, flush with each surface of gypsum board.

PASSIVE FIRE PROTECTION PARTNERS — 4100NS, 4800DW or 3600EX

*** Indicates such products shall bear the UL or cUL Certification Mark for jurisdictions employing the UL or cUL Certification (such as Canada), respectively.**

Last Updated on 2016-09-01

Design/System/Construction/Assembly Usage Disclaimer

- Authorities Having Jurisdiction should be consulted in all cases as to the particular requirements covering the installation and use of UL Certified products, equipment, system, devices, and materials.
- Authorities Having Jurisdiction should be consulted before construction.
- Fire resistance assemblies and products are developed by the design submitter and have been investigated by UL for compliance with applicable requirements. The published information cannot always address every construction nuance encountered in the field.
- When field issues arise, it is recommended the first contact for assistance be the technical service staff provided by the product manufacturer noted for the design. Users of fire resistance assemblies are advised to consult the general Guide Information for each product category and each group of assemblies. The Guide Information includes specifics concerning alternate materials and alternate methods of construction.
- Only products which bear UL's Mark are considered Certified.

The appearance of a company's name or product in this database does not in itself assure that products so identified have been manufactured under UL's Follow-Up Service. Only those products bearing the UL Mark should be considered to be Certified and covered under UL's Follow-Up Service. Always look for the Mark on the product.

UL permits the reproduction of the material contained in the Online Certification Directory subject to the following conditions: 1. The Guide Information, Assemblies, Constructions, Designs, Systems, and/or Certifications (files) must be presented in their entirety and in a non-misleading manner, without any manipulation of the data (or drawings). 2. The statement "Reprinted from the Online Certifications Directory with permission from UL" must appear adjacent to the extracted material. In addition, the reprinted material must include a copyright notice in the following format: "© 2019 UL LLC".

UL and the UL logo are trademarks of UL LLC © 2019 All Rights Reserved.

UL PRODUCT CATEGORY

Assembly Usage Disclaimer

XHBN - Joint Systems

XHBN7 - Joint Systems Certified for Canada

See General Information for Joint Systems

See General Information for Joint Systems Certified for Canada

System No. WW-S-0048

December 23, 2013

ANSI/UL2079	CAN/ULC S115
Assembly Ratings — 1 and 2 Hr (See Items 1 and 2)	F Ratings — 1 and 2 Hr (See Items 1 and 2)
Joint Width - 3/4 In. Max	FT Ratings — 1 and 2 Hr (See Items 1 and 2)
L Rating At Ambient — Less Than 1 CFM/sq ft (See Item 3)	FH Ratings — 1 and 2 Hr (See Items 1 and 2)
L Rating At 400 F — Less Than 1 CFM/sq ft (See Item 3)	FTH Ratings — 1 and 2 Hr (See Items 1 and 2)
	Joint Width - 3/4 In. Max
	L Rating At Ambient — Less Than 1 CFM/sq ft (See Item 3)
	L Rating At 400 F — Less Than 1 CFM/sq ft (See Item 3)

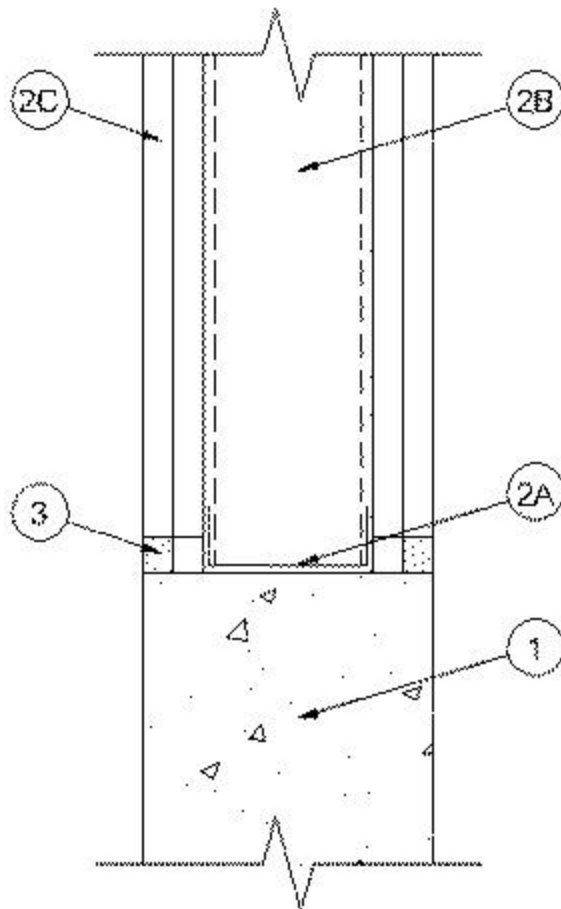

1. Concrete Wall Assembly — Min 4-3/4 in. (121 mm) and 6 in. (152 mm) thick reinforced lightweight or normal weight (100-150 pcf or 1600-24—kg/m³) structural concrete for 1 and 2 hr rated assemblies, respectively. Additionally, thickness of the concrete wall shall be equal to or greater than thickness of gypsum wall. Wall may also be constructed of any UL Classified **Concrete Blocks***. Top course of concrete blocks shall be either solid or filled with concrete.

See **Concrete Blocks** (CAZT) category in the Fire Resistance Directory for names of manufacturers.

2. Gypsum Wall Assembly — The 1 or 2 h fire rated gypsum board/steel stud wall assembly shall be constructed of the materials and in the manner specified in the individual U400, V400 or W400 Series Wall and Partition Design in the UL Fire Resistance Directory and shall include the following construction features:

A. Steel Floor Runners — Floor runners of wall assembly shall consist of min No. 25 gauge galv steel channels sized to accommodate steel studs (Item 2B). Runners to be provided with min 1-1/4 in. (32 mm) flanges. Runners secured to concrete wall assembly with steel concrete fasteners spaced max 24 in. (610 mm) OC.

B. Studs — Steel studs to be min 3-1/2 in. (89 mm) wide. Studs cut 1/2 to 3/4 in. (13 to 19 mm) less in length than assembly height with bottom nesting in, resting on and fastened to the floor runner with sheet metal screws. Stud spacing not to exceed 24 in. (610 mm) OC.

C. Gypsum Board* — For 1 hr assembly, single layer of 5/8 in. (16 mm) thick gypsum board is required on each side of wall as specified in the individual Wall and Partition Design. For 2 hr assembly, two layers of 5/8 in. (16 mm) thick gypsum board are required on each side of the wall as specified in the individual Wall and Partition Design. Wall to be constructed as specified in the individual U400, V400 or W400 Series Design except that a max 3/4 in. (19 mm) gap shall be maintained between the bottom of the gypsum board and the top of the concrete wall assembly.

The hourly fire rating of the joint system is equal to the hourly fire rating of the gypsum wall assembly.

3. Fill, Void or Cavity Material* Sealant — Max separation between bottom of gypsum board and top of concrete wall assembly is 3/4 in. (19 mm). Min 5/8 in. (16 mm) thickness of fill material installed on each side of the wall between the bottom of the gypsum board and the top of the concrete wall assembly, flush with each surface of the gypsum wall.

HILTI CONSTRUCTION CHEMICALS, DIV OF HILTI INC — CP601S Elastomeric Firestop Sealant, CP606 Flexible Firestop Sealant or CFS-S SIL GG Sealant. L Ratings apply only when CP606 or CFS-S SIL GG Sealant is used.

4. Forming Material — (Optional, Not Shown) - Mineral wool insulation, fiberglass batt insulation or polyurethane/polyethylene foam backer rod. Forming material to be recessed from both surfaces of the 2 hr fire rated wall to accommodate the required thickness of fill material.

*** Indicates such products shall bear the UL or cUL Certification Mark for jurisdictions employing the UL or cUL Certification (such as Canada), respectively.**

Last Updated on 2013-12-23

Design/System/Construction/Assembly Usage Disclaimer

- Authorities Having Jurisdiction should be consulted in all cases as to the particular requirements covering the installation and use of UL Certified products, equipment, system, devices, and materials.
- Authorities Having Jurisdiction should be consulted before construction.
- Fire resistance assemblies and products are developed by the design submitter and have been investigated by UL for compliance with applicable requirements. The published information cannot always address every construction nuance encountered in the field.
- When field issues arise, it is recommended the first contact for assistance be the technical service staff provided by the product manufacturer noted for the design. Users of fire resistance assemblies are advised to consult the general Guide Information for each product category and each group of assemblies. The Guide Information includes specifics concerning alternate materials and alternate methods of construction.
- Only products which bear UL's Mark are considered Certified.

The appearance of a company's name or product in this database does not in itself assure that products so identified have been manufactured under UL's Follow-Up Service. Only those products bearing the UL Mark should be considered to be Certified and covered under UL's Follow-Up Service. Always look for the Mark on the product.

UL permits the reproduction of the material contained in the Online Certification Directory subject to the following conditions: 1. The Guide Information, Assemblies, Constructions, Designs, Systems, and/or Certifications (files) must be presented in their entirety and in a non-misleading manner, without any manipulation of the data (or drawings). 2. The statement "Reprinted from the Online Certifications Directory with permission from UL" must appear adjacent to the extracted material. In addition, the reprinted material must include a copyright notice in the following format: "© 2019 UL LLC".

UL and the UL logo are trademarks of UL LLC © 2019 All Rights Reserved.

THROUGH-PENETRATION FIRESTOP SYSTEM

Assembly Usage Disclaimer

XHEZ - Through-penetration Firestop Systems

XHEZ7 - Through-penetration Firestop Systems Certified for Canada

See General Information for Through-penetration Firestop Systems

See General Information for Through-penetration Firestop Systems Certified for Canada

System No. C-AJ-1291

January 07, 2015

ANSI/UL1479 (ASTM E814)	CAN/ULC S115	
F Rating — 2 Hr	F Rating — 2 Hr	
T Rating — 0 Hr	FT Rating — 0 Hr	
	FH Rating — 2 Hr	
	FTH Rating — 0 Hr	

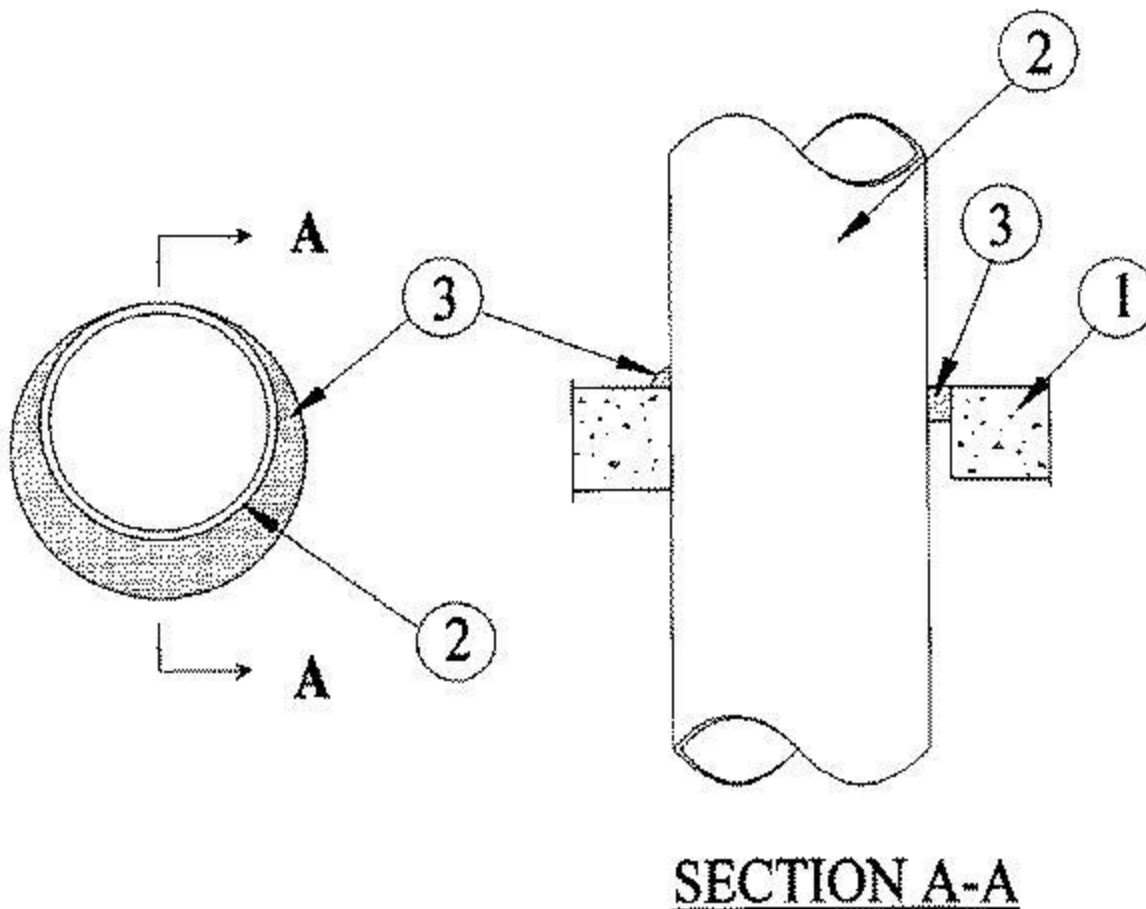

1. **Floor or Wall Assembly** — Min 2-1/2 in. (64 mm) thick reinforced lightweight or normal weight (100-150 pcf or 1600-2400 kg/m³) concrete. Wall may also be constructed of any UL Classified **Concrete Blocks***. Max diam of opening is 30-7/8 in. (784 mm).

See **Concrete Blocks** (CAZT) category in the Fire Resistance Directory for names of manufacturers.

2. **Through-Penetrant** — One metallic pipe or conduit to be installed either concentrically or eccentrically within the firestop system. The annular space between pipe or conduit and periphery of opening shall be min 0 in. to max 7/8 in. (22 mm). Pipe or conduit to be rigidly supported on both sides of floor or wall assembly. The following types and sizes of metallic pipes or conduits may be used:

A. **Steel Pipe** — Nom 30 in. (762 mm) diam (or smaller) Schedule 10 (or heavier) steel pipe.

B. **Iron Pipe** — Nom 30 in. (762 mm) diam (or smaller) cast or ductile iron pipe.

C. **Copper Pipe** — Nom 6 in. (152 mm) diam (or smaller) Regular (or heavier) copper pipe.

D. **Copper Tubing** — Nom 6 in. (152 mm) diam (or smaller) Type L (or heavier) copper tubing.

E. **Conduit** — Nom 6 in. (152 mm) diam (or smaller) steel conduit.

F. Conduit — Nom 4 in. (102 mm) diam (or smaller) steel electrical metallic tubing (EMT).

3. Fill, Void or Cavity Material* — Sealant — Min 1/2 in. (13 mm) thickness of fill material applied within the annulus, flush with top surface of floor or with both surfaces of wall. At the point contact location between pipe and concrete, a min 1/4 in. (6 mm) diam bead of fill material shall be applied at the concrete/pipe interface on the top surface of floor and on both surfaces of wall.

HILTI CONSTRUCTION CHEMICALS, DIV OF HILTI INC — FS-ONE Sealant or FS-ONE MAX Intumescent Sealant

*** Indicates such products shall bear the UL or cUL Certification Mark for jurisdictions employing the UL or cUL Certification (such as Canada), respectively.**

Last Updated on 2015-01-07

Design/System/Construction/Assembly Usage Disclaimer

- Authorities Having Jurisdiction should be consulted in all cases as to the particular requirements covering the installation and use of UL Certified products, equipment, system, devices, and materials.
- Authorities Having Jurisdiction should be consulted before construction.
- Fire resistance assemblies and products are developed by the design submitter and have been investigated by UL for compliance with applicable requirements. The published information cannot always address every construction nuance encountered in the field.
- When field issues arise, it is recommended the first contact for assistance be the technical service staff provided by the product manufacturer noted for the design. Users of fire resistance assemblies are advised to consult the general Guide Information for each product category and each group of assemblies. The Guide Information includes specifics concerning alternate materials and alternate methods of construction.
- Only products which bear UL's Mark are considered Certified.

The appearance of a company's name or product in this database does not in itself assure that products so identified have been manufactured under UL's Follow-Up Service. Only those products bearing the UL Mark should be considered to be Certified and covered under UL's Follow-Up Service. Always look for the Mark on the product.

UL permits the reproduction of the material contained in the Online Certification Directory subject to the following conditions: 1. The Guide Information, Assemblies, Constructions, Designs, Systems, and/or Certifications (files) must be presented in their entirety and in a non-misleading manner, without any manipulation of the data (or drawings). 2. The statement "Reprinted from the Online Certifications Directory with permission from UL" must appear adjacent to the extracted material. In addition, the reprinted material must include a copyright notice in the following format: "© 2019 UL LLC".

UL and the UL logo are trademarks of UL LLC © 2019 All Rights Reserved.

THROUGH-PENETRATION FIRESTOP SYSTEM

Assembly Usage Disclaimer

XHEZ - Through-penetration Firestop Systems

XHEZ7 - Through-penetration Firestop Systems Certified for Canada

See General Information for Through-penetration Firestop Systems

See General Information for Through-penetration Firestop Systems Certified for Canada

System No. C-AJ-3180

January 13, 2015

ANSI/UL1479 (ASTM E814)	CAN/ULC S115	
F Rating — 3 Hr	F Rating — 3 Hr	
T Rating — 0 Hr	FT Rating — 0 Hr	
	FH Rating — 3 Hr	
	FTH Rating — 0 Hr	

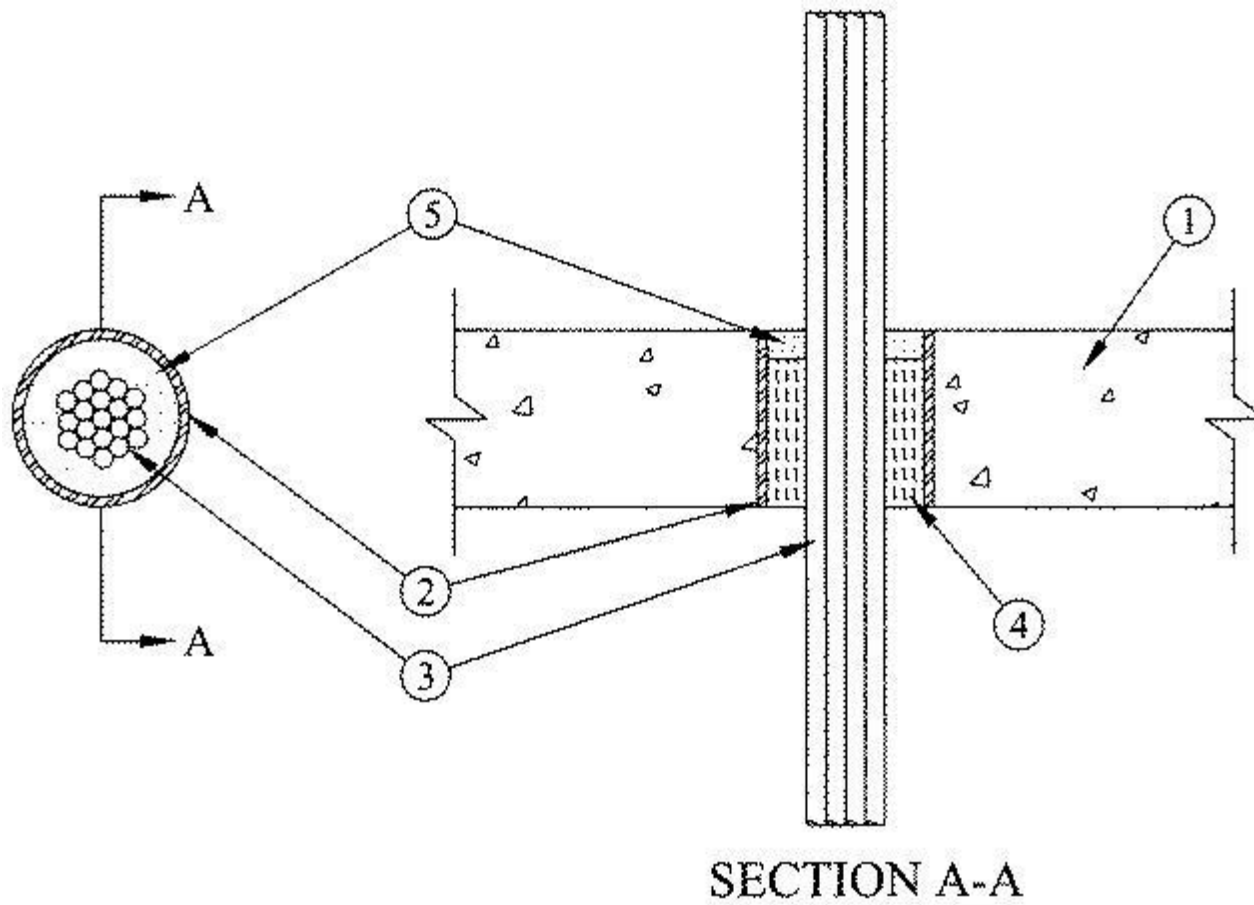

1. **Floor or Wall Assembly** — Min 4-1/2 in. (114 mm) thick reinforced lightweight or normal weight (100-150 pcf or 1600 2400 kg/m³) concrete floor or min 4-3/4 in. (121 mm) thick reinforced lightweight or normal weight concrete wall. Wall may also be constructed of any UL Classified **Concrete Blocks***. Max diam of opening is 6 in.(152 mm).

See **Concrete Blocks** (CAZT) category in the Fire Resistance Directory for names of manufacturers.

2. **Steel Sleeve** — (Optional) — Nom 6 in. (152 mm) diam (or smaller) Schedule 40 (or heavier) steel pipe cast or grouted into floor or wall assembly, flush with floor or wall surfaces.

3. **Cables** — Aggregate cross-sectional area of cables in opening to be max 45 percent of the aggregate cross-sectional area of the opening. Cables to be rigidly supported on both sides of floor or wall assembly. Any combination of the following types and sizes of metallic conductor or fiber optic cable may be used:

A. Max 500 kcmil single copper conductor power cable with thermoplastic insulation and polyvinyl chloride (PVC) jacket.

B. Max 300 pair No. 24 AWG copper conductor telecommunication cables with polyvinyl chloride (PVC) insulation and jacket material.

C. Max 7/C copper conductor No. 12 AWG multiconductor power and control cables with polyvinyl chloride (PVC) or cross-linked

polyethylene (XLPE) insulation and PVC jacket.

D. Multiple fiber optical communication cables jacketed with PVC and having a max outside diam of 1/2 in. (13 mm).

E. Max 3/C copper conductor No. 12 AWG with bare aluminum ground, polyvinyl chloride (PVC) insulated steel, Metal-clad cable.

F. Max 3/C with ground 2/0 AWG copper conductor SER cable with cross-linked polyethylene (XLPE) insulation and polyvinyl chloride (PVC) jacket.

G. RG/U coaxial cable with polyethylene (PE) insulation and polyvinyl chloride (PVC) jacket having a max outside diameter of 1/2 in. (13 mm)

H. Fire Resistive Cables* - Max 1-1/4 in. (32 mm) diam single conductor or multi conductor Type MI cable. A min 1/8 in. (3 mm) separation shall be maintained between MI cables and any other types of cable.

4. Packing Material — Min 4-1/4 in. (108 mm) thickness of min 4 pcf (64 kg/m³) mineral wool batt insulation firmly packed into opening as a permanent form. Packing material to be recessed from top surface of floor to accommodate the required thickness of fill material.

5. Fill, Void or Cavity Material* — Sealant — Min 1/4 in. (6.4 mm) thickness of fill material applied within the annulus, flush with top surface of floor or with both surfaces of wall.

HILTI CONSTRUCTION CHEMICALS, DIV OF HILTI INC — FS-One Sealant or FS-ONE MAX Intumescent Sealant

*** Indicates such products shall bear the UL or cUL Certification Mark for jurisdictions employing the UL or cUL Certification (such as Canada), respectively.**

Last Updated on 2015-01-13

Design/System/Construction/Assembly Usage Disclaimer

- Authorities Having Jurisdiction should be consulted in all cases as to the particular requirements covering the installation and use of UL Certified products, equipment, system, devices, and materials.
- Authorities Having Jurisdiction should be consulted before construction.
- Fire resistance assemblies and products are developed by the design submitter and have been investigated by UL for compliance with applicable requirements. The published information cannot always address every construction nuance encountered in the field.
- When field issues arise, it is recommended the first contact for assistance be the technical service staff provided by the product manufacturer noted for the design. Users of fire resistance

assemblies are advised to consult the general Guide Information for each product category and each group of assemblies. The Guide Information includes specifics concerning alternate materials and alternate methods of construction.

- Only products which bear UL's Mark are considered Certified.

The appearance of a company's name or product in this database does not in itself assure that products so identified have been manufactured under UL's Follow-Up Service. Only those products bearing the UL Mark should be considered to be Certified and covered under UL's Follow-Up Service. Always look for the Mark on the product.

UL permits the reproduction of the material contained in the Online Certification Directory subject to the following conditions: 1. The Guide Information, Assemblies, Constructions, Designs, Systems, and/or Certifications (files) must be presented in their entirety and in a non-misleading manner, without any manipulation of the data (or drawings). 2. The statement "Reprinted from the Online Certifications Directory with permission from UL" must appear adjacent to the extracted material. In addition, the reprinted material must include a copyright notice in the following format: "© 2019 UL LLC".

UL and the UL logo are trademarks of UL LLC © 2019 All Rights Reserved.

THROUGH-PENETRATION FIRESTOP SYSTEM

Assembly Usage Disclaimer

XHEZ - Through-penetration Firestop Systems

XHEZ7 - Through-penetration Firestop Systems Certified for Canada

See General Information for Through-penetration Firestop Systems

See General Information for Through-penetration Firestop Systems Certified for Canada

System No. W-J-7109

October 30, 2017

ANSI/UL1479 (ASTM E814)	CAN/ULC S115
F Rating — 2 Hr	F Rating — 2 Hr
T Rating — 0 Hr	FT Rating — 0 Hr
L Rating At Ambient — Less Than 1 CFM/sq ft	FH Rating — 2 Hr
L Rating At 400 F — Less Than 1 CFM/sq ft	FTH Rating — 0 Hr
	L Rating At Ambient — Less Than 1 CFM/sq ft
	L Rating At 400 F — Less Than 1 CFM/sq ft

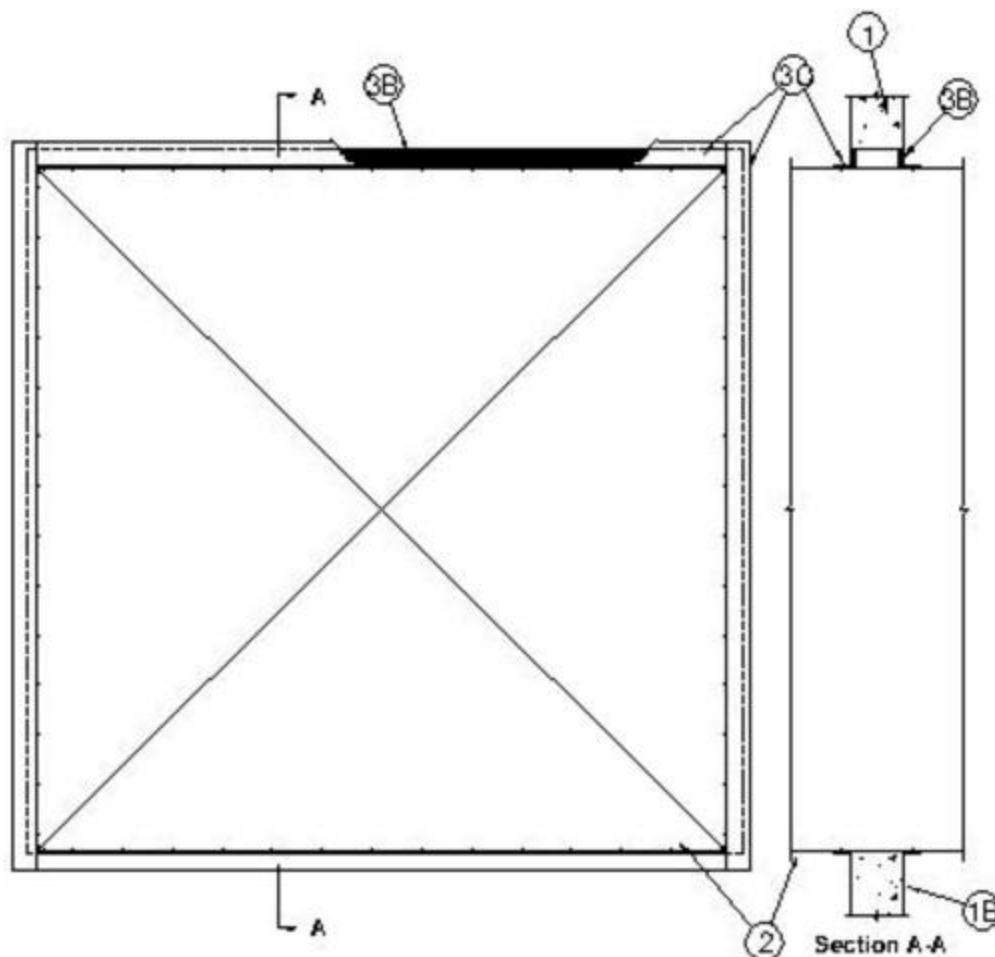

1. **Wall Assembly** — Min 6 in. (152 mm) thick reinforced lightweight or normal weight (100-150 pcf or 1600-2400 kg/m³) concrete. Wall may also be constructed of any UL Classified **Concrete Blocks***. Max area of opening is 73.7 sq ft (6.85 m²) with a max dimension of 104 in. (2.64 m).

See **Concrete Blocks** (CAZT) category in the Fire Resistance Directory for names of manufacturers.

2. **Steel Duct** — Max 100 in. by 100 in. (2.5 by 2.5 m) galv steel duct to be installed either concentrically or eccentrically within the firestop system. The duct shall be constructed and reinforced in accordance with SMACNA construction standards. The space between the steel duct and periphery of opening shall be min 0 in. (point contact) to max 2 in. (51 mm). Steel duct to be rigidly supported on both sides of the wall assembly.

2A. **Through-Penetrants — Coated Ducts*** — As an alternate to Item 2, rectangular steel air duct supplied coated with BW11 coating material. Max 40 by 40 in. (1.02 by 1.02 m) duct size. One duct to be installed within the firestop system with an annular space of min 0 in. (point contact) to max 2 in. (51 mm). Reinforcement stiffener or transverse joint with bolted flanges shall be located approximately at the mid depth of the annular space. Duct to be rigidly supported on both sides of the wall assembly. Duct sections shall be assembled using bolted flanges or SMACNA approved Transverse Joint Reinforcements.

FIRESPRAY INTERNATIONAL LTD — FLAMEBAR BW11 FIRE RATED DUCTWORK

3. Firestop System — The firestop system shall consist of the following:

A. Packing Material — (Optional, Not Shown) — Polyethylene backer rod, mineral wool batt insulation or fiberglass batt insulation friction fitted into annular space. Packing material to be recessed from both surfaces of wall to accommodate the required thickness of fill material.

A1. Packing Material — Required as specified in Table below. Min 3-3/4 in. (95 mm) thickness of min 4 pcf (64 kg/m³) mineral wool batt insulation firmly packed into opening as a permanent form. Packing material to be recessed from both surfaces of wall to accommodate the required thickness of fill material.

B. Fill, Void or Cavity Material* — Sealant — Min 5/8 in. (16 mm) thickness of fill material applied within the annulus, flush with both surfaces of wall. Min 1/4 in. (6 mm) diam bead of fill material shall be applied at the point contact location between the duct and the wall.
HILTI CONSTRUCTION CHEMICALS, DIV OF HILTI INC — FS-ONE Sealant or FS-ONE MAX Intumescent Sealant or CP606

C. Steel Retaining Angles — Min No. 16 gauge galv steel angles sized to lap steel duct a min of 2 in. (51 mm) and to lap wall surfaces a min of 1 in. (25 mm). When max duct dimension does not exceed 48 in. and duct area does not exceed 1300 in², angles may be min No. 18 gauge galv steel. Angles attached to steel duct or coated duct on both sides of wall with min No. 10 by 1/2 in. (13 mm) long steel sheet metal screws located a max of 1 in. (25 mm) from each end of duct and spaced a max of 6 in. (152 mm) OC. Steel angles are optional for those sides of duct that do not exceed the dimension specified in Table below, dependent on packing material and annular space as specified.

Max Duct Dimension	Duct Thickness	Annular Space	Packing Material	Angle (Item 3C) Required
24 in. (610 mm)	24 ga or heavier	1/2 in. min to 1 in. max (13 to 25 mm)	Item 3A1	No

* Indicates such products shall bear the UL or cUL Certification Mark for jurisdictions employing the UL or cUL Certification (such as Canada), respectively.

Last Updated on 2017-10-30

Design/System/Construction/Assembly Usage Disclaimer

- Authorities Having Jurisdiction should be consulted in all cases as to the particular requirements covering the installation and use of UL Certified products, equipment, system, devices, and materials.
- Authorities Having Jurisdiction should be consulted before construction.
- Fire resistance assemblies and products are developed by the design submitter and have been investigated by UL for compliance with applicable requirements. The published information cannot always address every construction nuance encountered in the field.
- When field issues arise, it is recommended the first contact for assistance be the technical service staff provided by the product manufacturer noted for the design. Users of fire resistance assemblies are advised to consult the general Guide Information for each product category and each group of assemblies. The Guide Information includes specifics concerning alternate materials and alternate methods of construction.
- Only products which bear UL's Mark are considered Certified.

The appearance of a company's name or product in this database does not in itself assure that products so identified have been manufactured under UL's Follow-Up Service. Only those products bearing the UL Mark should be considered to be Certified and covered under UL's Follow-Up Service. Always look for the Mark on the product.

UL permits the reproduction of the material contained in the Online Certification Directory subject to the following conditions: 1. The Guide Information, Assemblies, Constructions, Designs, Systems, and/or Certifications (files) must be presented in their entirety and in a non-misleading manner, without any manipulation of the data (or drawings). 2. The statement "Reprinted from the Online Certifications Directory with permission from UL" must appear adjacent to the extracted material. In addition, the reprinted material must include a copyright notice in the following format: "© 2019 UL LLC".

UL and the UL logo are trademarks of UL LLC © 2019 All Rights Reserved.

THROUGH-PENETRATION FIRESTOP SYSTEM

Assembly Usage Disclaimer

XHEZ - Through-penetration Firestop Systems

XHEZ7 - Through-penetration Firestop Systems Certified for Canada

See General Information for Through-penetration Firestop Systems

See General Information for Through-penetration Firestop Systems Certified for Canada

System No. W-L-1054

October 14, 2015

ANSI/UL1479 (ASTM E814)	CAN/ULC S115
F Ratings — 1 and 2 Hr (See Items 1 and 3)	F Ratings — 1 and 2 Hr (See Items 1 and 3)
T Rating — 0 Hr	FT Rating — 0 Hr
L Rating at Ambient — Less Than 1 CFM/sq ft	FH Ratings — 1 and 2 Hr (See Items 1 and 3)
L Rating at 400 F — Less Than 1 CFM/sq ft	FTH Rating — 0 Hr
	FTH Rating — 0 Hr L Rating at Ambient — Less Than 1 CFM/sq ft
	L Rating at 400 F — Less Than 1 CFM/sq ft

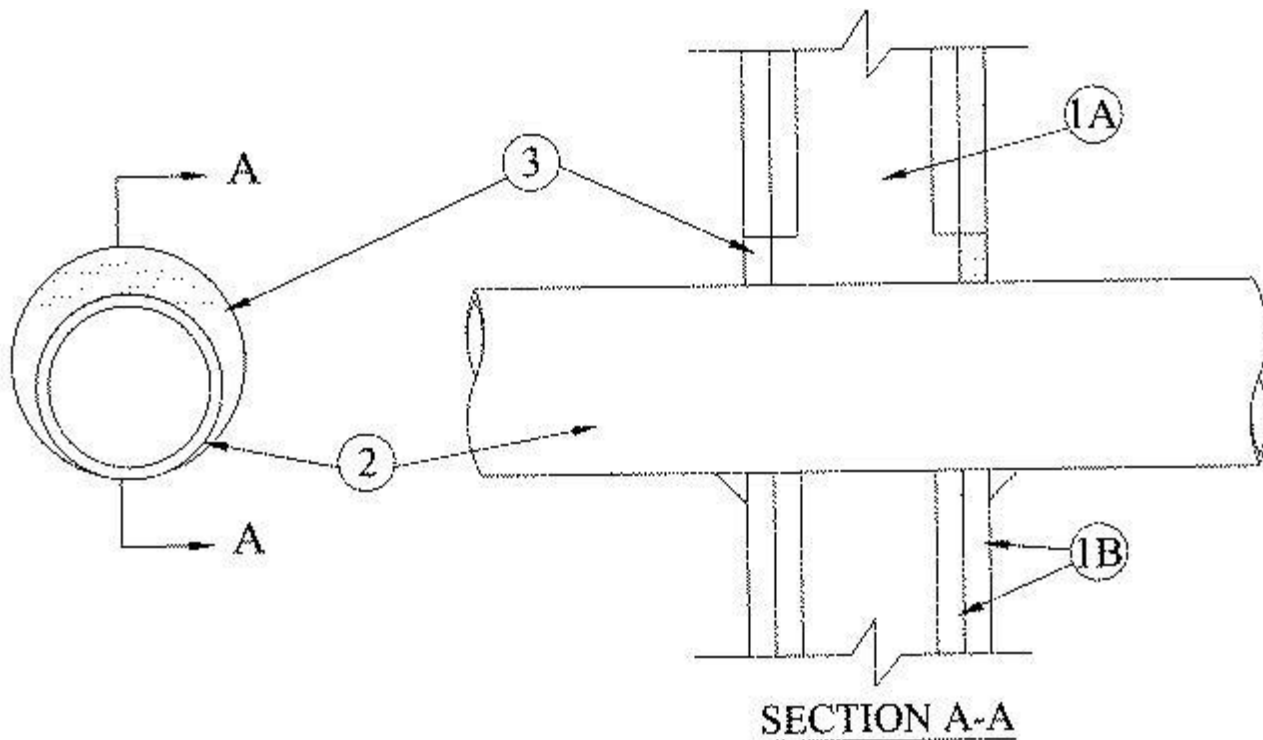

1. Wall Assembly — The 1 or 2 hr fire-rated gypsum wallboard/stud wall assembly shall be constructed of the materials and in the manner specified in the individual U300 or U400 Series Wall and Partition Designs in the UL Fire Resistance Directory and shall include the following construction features:

A. Studs — Wall framing may consist of either wood studs or steel channel studs. Wood studs to consist of nom 2 by 4 in. (51 by 102 mm) lumber spaced 16 in. (406 mm) OC. Steel studs to be min 2-1/2 in. (64 mm) wide and spaced max 24 in. (610 mm) OC. When steel studs are used and the diam of opening exceeds the width of stud cavity, the opening shall be framed on all sides using lengths of steel stud installed between the vertical studs and screw-attached to the steel studs at each end. The framed opening in the wall shall be 4 to 6 in. (102 to 152 mm) wider and 4 to 6 in. (102 to 152 mm) higher than the diam of the penetrating item such that, when the penetrating item is installed in the opening, a 2 to 3 in. (51 to 76 mm) clearance is present between the penetrating item and the framing on all four sides.

B. Gypsum Board* — 5/8 in. (16 mm) thick, 4 ft (122 cm) wide with square or tapered edges. The gypsum board type, thickness, number of layers, fastener type and sheet orientation shall be as specified in the individual U300 or U400 Series Design in the UL Fire Resistance Directory. Max diam of opening is 32-1/4 in. (819 mm) for steel stud walls. Max diam of opening is 14-1/2 in. (368 mm) for wood stud walls.

The F and FH Ratings of the firestop system are equal to the fire rating of the wall assembly.

2. Through-Penetrants — One metallic pipe, conduit or tubing to be installed either concentrically or eccentrically within the firestop system. The annular space shall be min 0 in. to max 2-1/4 in. (57 mm). Pipe may be installed with continuous point contact. Pipe, conduit or tubing to be rigidly supported on both sides of wall assembly. The following types and sizes of metallic pipes, conduits or tubing may be used:

A. **Steel Pipe** — Nom 30 in. (762 mm) diam (or smaller) Schedule 10 (or heavier) steel pipe.

B. **Iron Pipe** — Nom 30 in. (762 mm) diam (or smaller) cast or ductile iron pipe.

C. **Conduit** — Nom 4 in. (102 mm) diam (or smaller) steel electrical metallic tubing or 6 in. (152 mm) . diam steel conduit.

D. **Copper Tubing** — Nom 6 in. (152 mm) diam (or smaller) Type L (or heavier) copper tubing.

E. **Copper Pipe** — Nom 6 in. (152 mm) diam (or smaller) regular (or heavier) copper pipe.

3. Fill, Void or Cavity Material* — Sealant — Min 5/8 in. (16 mm) thickness of fill material applied within the annulus, flush with both surfaces of wall. At the point or continuous contact locations between pipe and wall, a min 1/2 in. (13 mm) diam bead of fill material shall be applied at the pipe wall interface on both surfaces of wall.

HILTI CONSTRUCTION CHEMICALS, DIV OF HILTI INC — FS-One Sealant or FS-ONE MAX Intumescent Sealant

*** Indicates such products shall bear the UL or cUL Certification Mark for jurisdictions employing the UL or cUL Certification (such as Canada), respectively.**

Last Updated on 2015-10-14

Design/System/Construction/Assembly Usage Disclaimer

- Authorities Having Jurisdiction should be consulted in all cases as to the particular requirements covering the installation and use of UL Certified products, equipment, system, devices, and materials.
- Authorities Having Jurisdiction should be consulted before construction.
- Fire resistance assemblies and products are developed by the design submitter and have been investigated by UL for compliance with applicable requirements. The published information cannot always address every construction nuance encountered in the field.
- When field issues arise, it is recommended the first contact for assistance be the technical service staff provided by the product manufacturer noted for the design. Users of fire resistance assemblies are advised to consult the general Guide Information for each product category and each group of assemblies. The Guide Information includes specifics concerning alternate materials and alternate methods of construction.
- Only products which bear UL's Mark are considered Certified.

The appearance of a company's name or product in this database does not in itself assure that products so identified have been manufactured under UL's Follow-Up Service. Only those products bearing the UL Mark should be considered to be Certified and covered under UL's Follow-Up Service. Always look for the Mark on the product.

UL permits the reproduction of the material contained in the Online Certification Directory subject to the following conditions: 1. The Guide Information, Assemblies, Constructions, Designs, Systems, and/or Certifications (files) must be presented in their entirety and in a non-misleading manner, without any manipulation of the data (or drawings). 2. The statement "Reprinted from the Online Certifications Directory with permission from UL" must appear adjacent to the extracted material. In addition, the reprinted material must include a copyright notice in the following format: "© 2019 UL LLC".

UL and the UL logo are trademarks of UL LLC © 2019 All Rights Reserved.

THROUGH-PENETRATION FIRESTOP SYSTEM

Assembly Usage Disclaimer

XHEZ - Through-penetration Firestop Systems

XHEZ7 - Through-penetration Firestop Systems Certified for Canada

See General Information for Through-penetration Firestop Systems

See General Information for Through-penetration Firestop Systems Certified for Canada

System No. W-L-3065

October 14, 2015

ANSI/UL1479 (ASTM E814)	CAN/ULC S115
F Rating — 1 and 2 Hr (See Item 1)	F Rating — 1 and 2 Hr (See Item 1)
T Rating — 0 and 3/4 Hr (See item 3)	FT Rating — 0 and 3/4 Hr (See item 3)
L Rating At Ambient — 15 CFM/sq ft	FH Rating — 1 and 2 Hr (See Item 1)
L Rating At 400 F — 8 CFM/sq ft	FTH Rating — 0 and 3/4 Hr (See item 3)
	L Rating At Ambient — 15 CFM/sq ft
	L Rating At 400 F — 8 CFM/sq ft

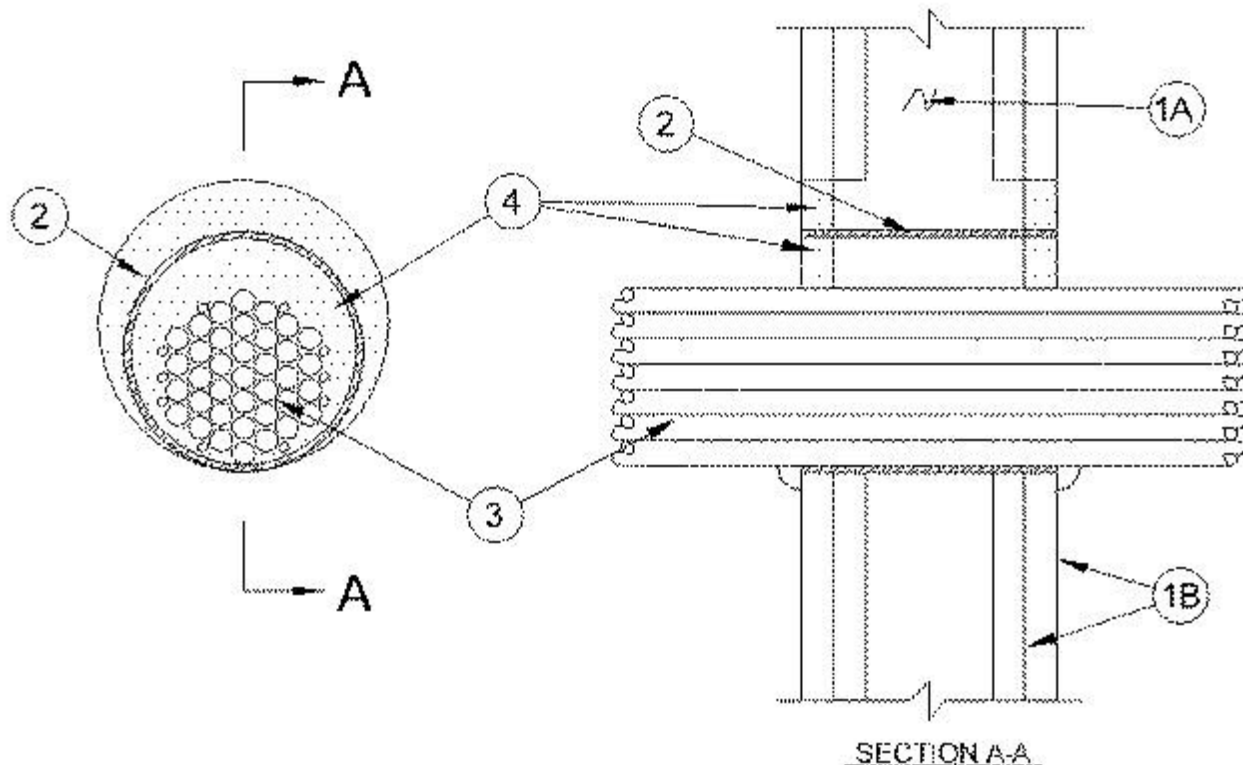

1. Wall Assembly — The 1 or 2 fire-rated gypsum wallboard/stud wall assembly shall be constructed of the materials and in the manner specified in the individual U300, U400, V400 or W400 Series Wall and Partition Designs in the UL Fire Resistance Directory and shall include the following construction features:

A. Studs — Wall framing may consist of either wood studs or steel channel studs. Wood studs to consist of nom 2 by 4 in. (51 by 102 mm) lumber spaced 16 in. (406 mm) OC. Steel studs to be min 2-1/2 in. (64 mm) wide and spaced max 24 in. (610 mm) OC.

B. Gypsum Board* — Nom 5/8 in. (16 mm) thick gypsum board, with square or tapered edges. The gypsum board type, thickness, number of layers, fastener type and sheet orientation shall be as specified in the individual Wall and Partition Design in the UL Fire Resistance Directory. Max diam of opening is 5-1/2 in. (138 mm) when sleeve (Item 2) is employed. Max diam of opening is 4 in. (102 mm) when sleeve (Item 2) is not employed.

The F, FH Ratings of the firestop system are equal to the fire rating of the wall assembly.

2. Metallic Sleeve — (Optional) - Nom 4 in. (102 mm) diam (or smaller) steel electrical metallic tubing (EMT) or Schedule 5 (or heavier) steel pipe or min 0.016 in. thick (0.41 mm, No. 28 ga) galv steel sleeve installed flush with wall surfaces. The annular space between steel sleeve and periphery of opening shall be min 0 in. (0 mm, point contact) to max 1 in. (25mm). When Schedule 5 steel pipe or EMT is used, sleeve may extend up to 18 in. (457 mm) beyond the wall surfaces. As an option when Schedule 5 steel pipe or EMT is used, sleeve may extend continuously beyond one wall surface. When cable bundle penetrates wall assembly at an angle of 45 degrees, no metallic sleeve is used.

3. **Cables** — Aggregate cross-sectional area of cable in opening to be max 45 percent of the cross-sectional area of the opening. The annular space between the cable bundle and the periphery of the opening to be min 0 in. (point contact) to max 1 in. (25 mm). When sleeve is continuous on one side of wall (see Item 2), the cable fill may be 0 to 45% and the max annular space is not limited. Cables to be rigidly supported on both sides of the wall assembly. Any combination of the following types and sizes of copper conductor cables may be used:

A. Max 7/C No. 12 AWG with polyvinyl chloride (PVC) insulation and jacket.

B. Max 25 pair No. 24 AWG telephone cable with PVC insulation and jacket.

B1. Max 4 pr No. 22 AWG Cat 5 or Cat 6 computer cables.

C. Type RG/U coaxial cable with polyethylene (PE) insulation and PVC jacket having a max outside diameter of 1/2 in. (13 mm).

C1. Max RG 6/U coaxial cable with fluorinated ethylene insulation and jacketing.

D. Multiple fiber optical communication cable jacketed with PVC and having a max OD of 5/8 in. (16 mm).

E. Through Penetrating Products*— Max three copper conductor No. 8 AWG **Metal-Clad Cable+**.
AFC CABLE SYSTEMS INC

F. Max 3/C (with ground)(or smaller) No. 8 AWG copper conductor cable with PVC insulation and jacketing.

G. Max 3/4 in. (19 mm) diam copper ground cable with or without a PVC jacket.

H. Fire Resistive Cables* - Max 1-1/4 in. (32 mm) diam single conductor or multi conductor Type MI cable. A min 1/8 in. (3 mm) separation shall be maintained between MI cables and any other types of cable.

I. Max 4/C with ground 300 kcmil (or smaller) aluminum SER cable with PVC insulation and jacket.

J. **Through Penetrating Product*** - Any cables, **Metal-Clad Cable+** or **Armored Cable+** currently Classified under the **Through Penetrating Products** category.

K. Maximum 3/C No. 8 AWG metal-clad cable.

L. Maximum 5/8 diam fiber-optic cable with PVC jacket.

For cable bundle penetrating the wall assembly at an angle of 45 degrees, the T, FT, FTH Ratings are 0 hr and 3/4 hr for 1 and 2 hr wall assemblies, respectively.

See **Through Penetrating Product (XHLY)** category in the Fire Resistance Directory for names of manufacturers.

4. Fill, Void or Cavity Material*— Sealant or Putty — Fill material applied within the annulus, flush with each end of the steel sleeve or wall surface. Fill material installed symmetrically on both sides of the wall. A min 5/8 in. (16 mm) thickness of sealant is required for the 1 or 2 hr F Rating . An additional 1/2 in. (13 mm) diam bead of fill material shall be applied at the interface of sleeve with gypsum board.

HILTI CONSTRUCTION CHEMICALS, DIV OF HILTI INC — CP601S, CP606, FS-One Sealants or FS-ONE MAX Intumescent Sealant or CP618 Putty

5. Packing Material — (Optional, Not Shown) — Mineral wool forming material may be used as a backer for the fill material (Item 4). When used, it shall be firmly packed into annular space within the sleeve as a permanent form and recessed from end of sleeve to accommodate the required thickness of fill material.

*** Indicates such products shall bear the UL or cUL Certification Mark for jurisdictions employing the UL or cUL Certification (such as Canada), respectively.**

+Bearing the UL Listing Mark

Last Updated on 2015-10-14

Design/System/Construction/Assembly Usage Disclaimer

- Authorities Having Jurisdiction should be consulted in all cases as to the particular requirements covering the installation and use of UL Certified products, equipment, system, devices, and materials.
- Authorities Having Jurisdiction should be consulted before construction.
- Fire resistance assemblies and products are developed by the design submitter and have been investigated by UL for compliance with applicable requirements. The published information cannot always address every construction nuance encountered in the field.
- When field issues arise, it is recommended the first contact for assistance be the technical service staff provided by the product manufacturer noted for the design. Users of fire resistance assemblies are advised to consult the general Guide Information for each product category and each group of assemblies. The Guide Information includes specifics concerning alternate materials and alternate methods of construction.
- Only products which bear UL's Mark are considered Certified.

The appearance of a company's name or product in this database does not in itself assure that products so identified have been manufactured under UL's Follow-Up Service. Only those products bearing the UL Mark should be considered to be Certified and covered under UL's Follow-Up Service. Always look for the Mark on the product.

UL permits the reproduction of the material contained in the Online Certification Directory subject to the following conditions: 1. The Guide Information, Assemblies, Constructions, Designs, Systems, and/or Certifications (files) must be presented in their entirety and in a non-misleading manner, without any

manipulation of the data (or drawings). 2. The statement "Reprinted from the Online Certifications Directory with permission from UL" must appear adjacent to the extracted material. In addition, the reprinted material must include a copyright notice in the following format: "© 2019 UL LLC".

UL and the UL logo are trademarks of UL LLC © 2019 All Rights Reserved.

THROUGH-PENETRATION FIRESTOP SYSTEM

Assembly Usage Disclaimer

XHEZ - Through-penetration Firestop Systems

XHEZ7 - Through-penetration Firestop Systems Certified for Canada

See General Information for Through-penetration Firestop Systems

See General Information for Through-penetration Firestop Systems Certified for Canada

System No. W-L-4011

July 12, 2016

ANSI/UL1479 (ASTM E814)	CAN/ULC S115	
F Ratings — 1 and 2 Hr (See Item 1)	F Ratings — 1 and 2 Hr (See Item 1)	
T Rating — 0 Hr	FT Rating — 0 Hr	
L Rating At Ambient — 5 CFM/sq ft	FH Ratings — 1 and 2 Hr (See Item 1)	
L Rating At 400 F — 2 CFM/sq ft	FTH Rating — 0 Hr	
	L Rating At Ambient — 5 CFM/sq ft	
	L Rating At 400 F — 2 CFM/sq ft	

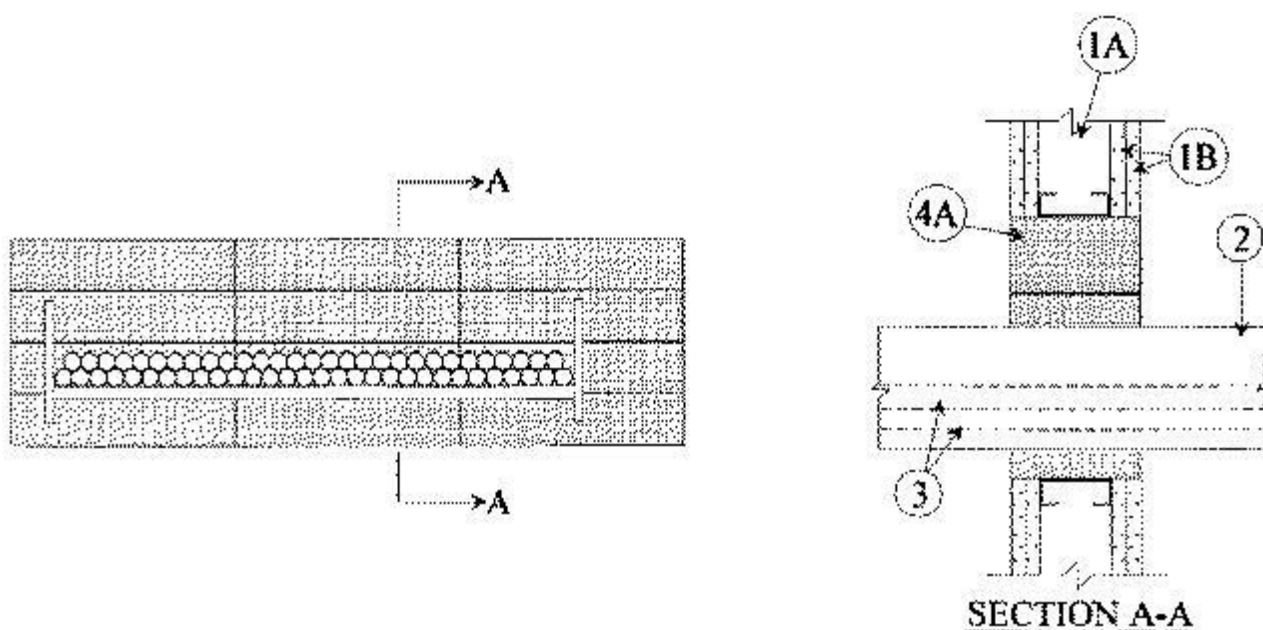

1. **Wall Assembly** — The 1 or 2 hr fire rated gypsum board/stud wall assembly shall be constructed of the materials and in the manner described in the individual U300, U400,

V400 or W400 Series Wall and Partition Designs in the UL Fire Resistance Directory and shall include the following construction features:

A. **Studs** — Wall framing may consist of either wood studs or steel channel studs. Wood studs to consist of nom 2 in. (51 mm) by 4 in. (102 mm) lumber spaced 16 in. (406 mm) OC. Steel studs to be min 2-1/2 in. (64 mm) wide and spaced max 24 in. (610 mm) OC. Additional framing member shall be installed in stud cavity containing through-penetrating item to form a rectangular box around penetrant.

B. **Gypsum Board*** — 5/8 in. (16 mm) thick, 4 ft (1219 cm) wide with square or tapered edges. The gypsum board type, thickness, number of layers, fastener type and sheet orientation shall be as specified in the individual Wall and Partition Design in the UL Fire Resistance Directory. Max size of opening 9 in. (229 mm) by 30 in. (762 mm).
The hourly F and FH Ratings of the firestop system are equal to the hourly fire rating of the wall assembly in which it is installed.

Min finished wall thickness is 5 in. (127 mm).

2. **Cable Tray*** — Max 24 in. (610 mm) wide by max 6 in. (152 mm) deep open-ladder or solid-back cable tray with channel-shaped side rails formed of 0.10 in. (2.54 mm) thick aluminum or 0.060 in. (1.54 mm) thick steel and with 1-1/2 in. (38 mm) wide by 1 in. (25 mm) channel shape rungs spaced 9 in. (229 mm) OC or a 0.029 in. (0.74 mm) thick steel solid back, respectively. The annular space between the cable tray and the periphery of the opening shall be min 0 in. (point contact) to max 4 in. (102 mm). Cable tray to be rigidly supported on both sides of floor or wall assembly.

3. **Cables** — Aggregate cross-sectional area of cables in cable tray to be max 45 percent of the cross-sectional area of the cable tray based on a max 5 in. (127 mm) cable loading depth. Any combination of the following types and sizes of copper conductor cables may be used:

A. 1/C, 750 kcmil (or smaller) power cable with EPR insulation and PVC jacket.

B. 300 pair - No. 24 AWG cable with PVC insulation and jacket

C. Twenty-four fiberoptic cable with PVC subunit and jacket.

D. Max three 1/C, No. 12 AWG wire, insulated with polyvinyl chloride, in a nom 3/4 in. (19 mm) **Flexible Metal Conduit+**.

4. **Firestop System** — The firestop system shall consist of the following:

A. **Fill, Void or Cavity Material* — Fire Blocks** — For walls incorporating max 3-5/8 in. (92 mm) steel studs or max 2 in. (51 mm) by 4 in. (102 mm) wood studs, fire block installed with 5 in. (127 mm) dimension projecting through and centered in opening. For walls constructed of larger steel or wood studs, fire block installed with long dimension passing through and centered in opening. Blocks may or may not be cut flush with both surfaces of wall. When multiple layers of

gypsum board are used, blocks may be recessed 1/2 in. (13 mm) from surface of wall. Blocks firmly packed within opening. Either one or a combination of the block types specified below may be used.

HILTI CONSTRUCTION CHEMICALS, DIV OF HILTI INC — CFS-BL Firestop Block

B. Fill, Void or Cavity Material* — Sealant or Putty — (Not Shown)
— Fill material to be forced into interstices of cables and between cables and cable trays to max extent possible on both surfaces of the penetration.

HILTI CONSTRUCTION CHEMICALS, DIV OF HILTI INC — FS-ONE Sealant, FS-ONE MAX Intumescent Sealant or CP618 Firestop Putty Stick (Note: L Ratings apply only when FS-One Sealant is used)

+ Bearing the UL Listing Mark

*** Indicates such products shall bear the UL or cUL Certification Mark for jurisdictions employing the UL or cUL Certification (such as Canada), respectively.**

Last Updated on 2016-07-12

Design/System/Construction/Assembly Usage Disclaimer

- Authorities Having Jurisdiction should be consulted in all cases as to the particular requirements covering the installation and use of UL Certified products, equipment, system, devices, and materials.
- Authorities Having Jurisdiction should be consulted before construction.
- Fire resistance assemblies and products are developed by the design submitter and have been investigated by UL for compliance with applicable requirements. The published information cannot always address every construction nuance encountered in the field.
- When field issues arise, it is recommended the first contact for assistance be the technical service staff provided by the product manufacturer noted for the design. Users of fire resistance assemblies are advised to consult the general Guide Information for each product category and each group of assemblies. The Guide Information includes specifics concerning alternate materials and alternate methods of construction.
- Only products which bear UL's Mark are considered Certified.

The appearance of a company's name or product in this database does not in itself assure that products so identified have been manufactured under UL's Follow-Up Service. Only those products bearing the UL Mark should be considered to be Certified and covered under UL's Follow-Up Service. Always look for the Mark on the product.

UL permits the reproduction of the material contained in the Online Certification Directory subject to the following conditions: 1. The Guide Information, Assemblies, Constructions, Designs, Systems, and/or Certifications (files) must be presented in their entirety and in a non-misleading manner, without any manipulation of the data (or drawings). 2. The statement "Reprinted from the Online Certifications

Directory with permission from UL" must appear adjacent to the extracted material. In addition, the reprinted material must include a copyright notice in the following format: "© 2019 UL LLC".

UL and the UL logo are trademarks of UL LLC © 2019 All Rights Reserved.

THROUGH-PENETRATION FIRESTOP SYSTEM

Assembly Usage Disclaimer

XHEZ - Through-penetration Firestop Systems

XHEZ7 - Through-penetration Firestop Systems Certified for Canada

See General Information for Through-penetration Firestop Systems

See General Information for Through-penetration Firestop Systems Certified for Canada

System No. W-L-7155

December 26, 2017

ANSI/UL1479 (ASTM E814)	CAN/ULC S115
F Ratings — 1 and 2 Hr (See Item 1)	F Ratings — 1 and 2 Hr (See Item 1)
T Ratings — 0 Hr	FT Ratings — 0 Hr
L Rating at Ambient — Less Than 1 CFM/sq ft	FH Ratings — 1 and 2 Hr (See Item 1)
L Rating at 400 F — Less Than 1 CFM/sq ft	FTH Ratings — 0 Hr
	L Rating at Ambient — Less Than 1 CFM/sq ft
	L Rating at 400 F — Less Than 1 CFM/sq ft

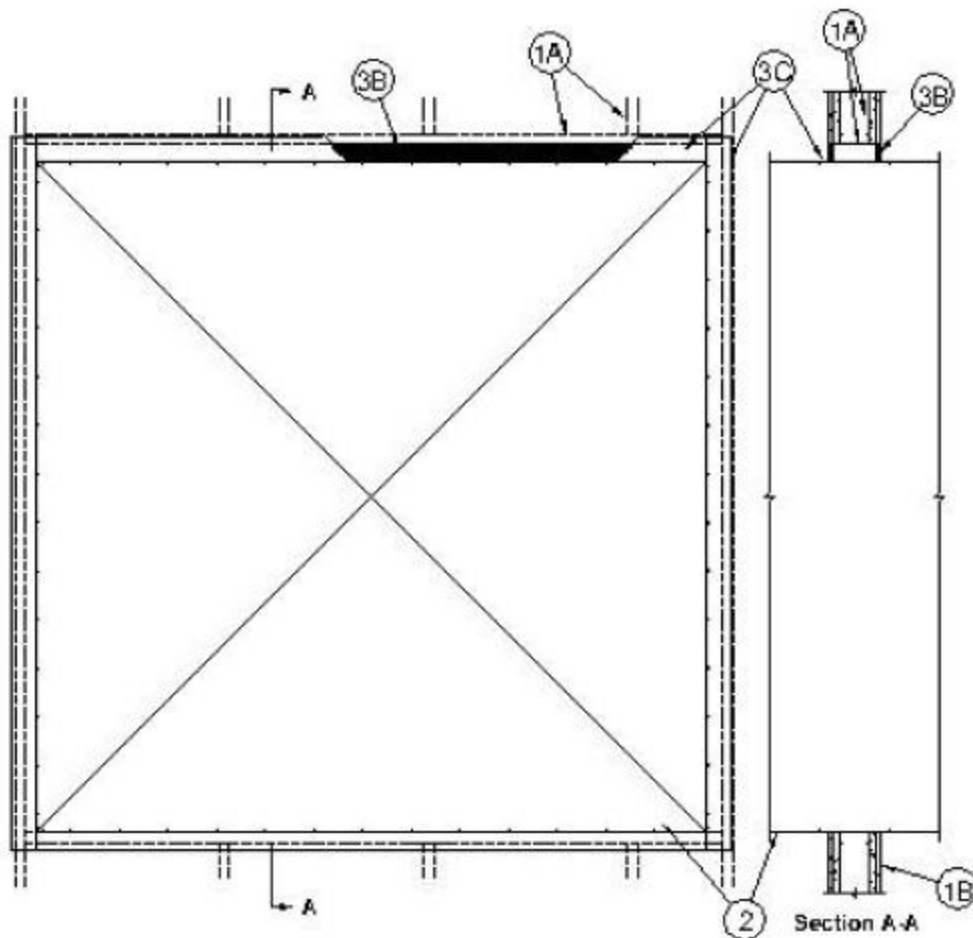

1. Wall Assembly — The 1 or 2 hr fire-rated gypsum wallboard/stud wall assembly shall be constructed of the materials and in the manner described in the individual U400, V400 or W400 Series Wall or Partition Design in the UL Fire Resistance Directory and shall include the following construction features:

A. Studs — Wall framing shall consist of min 3-1/2 in. (89 mm) wide steel channel studs spaced max 24 in. (610 mm) OC. Additional steel studs shall be used to completely frame the opening.

B. Gypsum Board* — 5/8 in. (16 mm) thick, 4 ft (1.22 m) wide with square or tapered edges. The gypsum board type, thickness, number of layers, fastener type and sheet orientation shall be as specified in the individual Wall and Partition Design in the UL Fire Resistance Directory. Max area of opening is 73.7 sq ft (6.85 m²) with a max dimension of 104 in. (2.64 m).

The hourly F and FH Ratings of the firestop system are equal to the hourly fire rating of the wall assembly in which it is installed.

2. Steel Duct — Max 100 in. by 100 in. (2.5 by 2.5 m) galv steel duct to be installed either concentrically or eccentrically within the firestop system. The duct shall be constructed and reinforced in accordance with SMACNA construction standards. The space between the steel duct and periphery of opening shall be min 0 in. (point contact) to max 2 in. (51 mm). Steel duct to be rigidly supported on both sides of the wall assembly.

2A1. Through-Penetrating Product* — As an alternate to Item 2. Fiber cement with galvanized steel facing, 3/8 in.(10 mm) thick composite metallic duct, with a max cross-sectional area of 43.0 sq ft, (4 m²) and a max individual dimension of 78 3/4 in. (2 m). Duct to be installed either concentrically or eccentrically within the firestop system such that the annular space is min 0 in. (point contact) to max 2 in. (51 mm). Duct to be rigidly supported on both sides of wall assembly. Refer to Ventilation Duct Assemblies in Vol. 2 of the Fire Resistance Directory.

DURASYSTEMS BARRIERS INC — Type DuraDuct HP.

2A3. Through-Penetrating Product* — As an alternate to Item 2. Galvanized steel faced duct panel, with a max cross-sectional area of 2450 sq in. (1.58 m²), and a max individual dimension of 49-1/2 in. (1258 mm) Duct to be installed either concentrically or eccentrically within the firestop system such that the annular space is min 0 in. (point contact) to max 2 in. (51 mm). Duct to be rigidly supported on both sides wall assembly. Refer to Ventilation Duct Assemblies in Vol. 2 of the Fire Resistance Directory.

DURASYSTEMS BARRIERS INC — Type DuraDuct GNX.

2A4. Through-Penetrants — Coated Ducts* — As an alternate to Item 2, rectangular steel air duct supplied coated with BW11 coating material. Max 40 by 40 in. (1.02 by 1.02 m) duct size. One duct to be installed within the firestop system with an annular space of min 0 in. (point contact) to max 2 in. (51 mm). Reinforcement stiffener or transverse joint with bolted flanges shall be located approximately at the mid depth of the annular space. Duct to be rigidly supported on both sides of the wall assembly. Duct sections shall be assembled using bolted flanges or SMACNA approved Transverse Joint Reinforcements.

FIRESPRAY INTERNATIONAL LTD — FLAMEBAR BW11 FIRE RATED DUCTWORK

3 Firestop System — The firestop system shall consist of the following:

A. Packing Material — (Optional, Not Shown) — Polyethylene backer rod, mineral wool batt insulation or fiberglass batt insulation friction fitted into annular space. Packing material to be recessed from both surfaces of wall to accommodate the required thickness of fill material.

A1. Packing Material — Required as specified in Table below. Min 3-3/4 in. (95 mm) or 5 in. (127 mm) thickness of min 4 pcf (64 kg/m³) mineral wool batt insulation firmly packed into opening as a permanent form for 1 and 2 hr rated assemblies, respectively. Packing material to be recessed from both surfaces of wall to accommodate the required thickness of fill material.

B. Fill, Void or Cavity Material* — Sealant — Min 5/8 in. (16 mm) thickness of fill material applied within the annulus, flush with both

surfaces of wall. Min 1/4 in. (6 mm) diam bead of fill material shall be applied at the point contact location between the steel duct or coated duct and the gypsum board.

HILTI CONSTRUCTION CHEMICALS, DIV OF HILTI INC — CFS-S SIL GG Sealant, FS-ONE Sealant, FS-ONE MAX Intumescent Sealant or CP606 Flexible Firestop Sealant

C. Steel Retaining Angles — Min No. 16 gauge galv steel angles sized to lap steel duct a min of 2 in. (51 mm) and to lap wall surfaces a min of 1 in. (25 mm). When max duct dimension does not exceed 48 in. (122 cm) and duct area does not exceed 1300 in² (8387 cm²), angles may be min No. 18 gauge galv steel. Angles attached to steel duct or coated duct on both sides of wall with min No. 10 by 1/2 in. (13 mm) long steel sheet metal screws located a max of 1 in. (25 mm) from each end of steel duct and spaced a max of 6 in. (152 mm) OC. Steel angles are optional for those sides of duct that do not exceed the dimension specified in Table below, dependent on packing material, sealant and annular space as specified.

Max Duct Dimension	Duct Thickness	Annular Space	Sealant	Packing Material	Angle (Item 3C) Required
24 in. (610 mm)	24 ga or heavier	1/2 in. min to 1 in. max (13 to 25 mm)	FS-ONE Sealant or CP606 Flexible Firestop Sealant	Item 3A1	No

* Indicates such products shall bear the UL or cUL Certification Mark for jurisdictions employing the UL or cUL Certification (such as Canada), respectively.

Last Updated on 2017-12-26

Design/System/Construction/Assembly Usage Disclaimer

- Authorities Having Jurisdiction should be consulted in all cases as to the particular requirements covering the installation and use of UL Certified products, equipment, system, devices, and materials.
- Authorities Having Jurisdiction should be consulted before construction.
- Fire resistance assemblies and products are developed by the design submitter and have been investigated by UL for compliance with applicable requirements. The published information cannot always address every construction nuance encountered in the field.

- When field issues arise, it is recommended the first contact for assistance be the technical service staff provided by the product manufacturer noted for the design. Users of fire resistance assemblies are advised to consult the general Guide Information for each product category and each group of assemblies. The Guide Information includes specifics concerning alternate materials and alternate methods of construction.
- Only products which bear UL's Mark are considered Certified.

The appearance of a company's name or product in this database does not in itself assure that products so identified have been manufactured under UL's Follow-Up Service. Only those products bearing the UL Mark should be considered to be Certified and covered under UL's Follow-Up Service. Always look for the Mark on the product.

UL permits the reproduction of the material contained in the Online Certification Directory subject to the following conditions: 1. The Guide Information, Assemblies, Constructions, Designs, Systems, and/or Certifications (files) must be presented in their entirety and in a non-misleading manner, without any manipulation of the data (or drawings). 2. The statement "Reprinted from the Online Certifications Directory with permission from UL" must appear adjacent to the extracted material. In addition, the reprinted material must include a copyright notice in the following format: "© 2019 UL LLC".

UL and the UL logo are trademarks of UL LLC © 2019 All Rights Reserved.

SECTION 07 92 00 - JOINT SEALANTS

PART 1 - GENERAL

1.1 RELATED DOCUMENTS

- A. Drawings and general provisions of the Contract, including General and Supplementary Conditions and Division 1 Specification Sections, apply to this Section.

1.2 SUMMARY

- A. This Section includes sealants for the following applications, including those specified by reference to this Section:
 - 1. Exterior joints in the following vertical surfaces and nontraffic horizontal surfaces:
 - a. Perimeter joints between materials listed above and frames of doors and windows.
 - 2. Exterior joints in the following horizontal traffic surfaces:
 - a. Control, expansion, and isolation joints in cast-in-place concrete slabs.
 - 3. Interior joints in the following vertical surfaces and horizontal nontraffic surfaces:
 - a. Vertical control joints on exposed surfaces of interior unit masonry and concrete walls and partitions.
 - b. Perimeter joints between interior wall surfaces and frames of interior doors, windows, and elevator entrances.
 - c. Joints between plumbing fixtures and adjoining walls, floors, and counters.
 - d. Other joints as indicated.

1.3 PERFORMANCE REQUIREMENTS

- A. Provide elastomeric joint sealants that establish and maintain watertight and airtight continuous joint seals without staining or deteriorating joint substrates.

1.4 SUBMITTALS

- A. Product Data: For each joint-sealant product indicated.

1.5 DELIVERY, STORAGE, AND HANDLING

- A. Deliver materials to Project site in original unopened containers or bundles with labels indicating manufacturer, product name and designation, color, expiration date, pot life, curing time, and mixing instructions for multicomponent materials.

- B. Store and handle materials in compliance with manufacturer's written instructions to prevent their deterioration or damage due to moisture, high or low temperatures, contaminants, or other causes.

1.6 PROJECT CONDITIONS

- A. Environmental Limitations: Do not proceed with installation of joint sealants under the following conditions:
 - 1. When ambient and substrate temperature conditions are outside limits permitted by joint sealant manufacturer.
- B. Joint-Width Conditions: Do not proceed with installation of joint sealants where joint widths are less than those allowed by joint sealant manufacturer for applications indicated.
- C. Joint-Substrate Conditions: Do not proceed with installation of joint sealants until contaminants capable of interfering with adhesion are removed from joint substrates.

PART 2 - PRODUCTS

2.1 PRODUCTS AND MANUFACTURERS

- A. Products: Subject to compliance with requirements, provide one of the products indicated for each type in the sealant schedules at the end of Part 3.

2.2 MATERIALS, GENERAL

- A. Compatibility: Provide joint sealants, backings, and other related materials that are compatible with one another and with joint substrates under conditions of service and application, as demonstrated by sealant manufacturer based on testing and field experience.
- B. Colors of Exposed Joint Sealants: As selected by Architect from manufacturer's full range for this characteristic.

2.3 ELASTOMERIC JOINT SEALANTS

- A. Elastomeric Sealant Standard: Comply with ASTM C 920 and other requirements indicated for each liquid-applied chemically curing sealant in the Elastomeric Joint-Sealant Schedule at the end of Part 3, including those referencing ASTM C 920 classifications for type, grade, class, and uses.

2.4 ACOUSTICAL JOINT SEALANTS

- A. Acoustical Sealant for Exposed and Concealed Joints: For each product of this description indicated in the Acoustical Joint-Sealant Schedule at the end of Part 3, provide manufacturer's standard nonsag, paintable, nonstaining latex sealant complying with ASTM C 834 and the following:

1. Product effectively reduces airborne sound transmission through perimeter joints and openings in building construction as demonstrated by testing representative assemblies according to ASTM E 90.

2.5 JOINT-SEALANT BACKING

- A. General: Provide sealant backings of material and type that are nonstaining; are compatible with joint substrates, sealants, primers, and other joint fillers; and are approved for applications indicated by sealant manufacturer based on field experience and laboratory testing.

2.6 MISCELLANEOUS MATERIALS

- A. Primer: Material recommended by joint sealant manufacturer where required for adhesion of sealant to joint substrates indicated, as determined from preconstruction joint-sealant-substrate tests and field tests.
- B. Cleaners for Nonporous Surfaces: Chemical cleaners acceptable to manufacturers of sealants and sealant backing materials, free of oily residues or other substances capable of staining or harming joint substrates and adjacent nonporous surfaces in any way, and formulated to promote optimum adhesion of sealants with joint substrates.
- C. Masking Tape: Nonstaining, nonabsorbent material compatible with joint sealants and surfaces adjacent to joints.

PART 3 - EXECUTION

3.1 EXAMINATION

- A. Examine joints indicated to receive joint sealants, with Installer present, for compliance with requirements for joint configuration, installation tolerances, and other conditions affecting joint-sealant performance.
- B. Proceed with installation only after unsatisfactory conditions have been corrected.

3.2 PREPARATION

- A. Surface Cleaning of Joints: Clean out joints immediately before installing joint sealants to comply with joint sealant manufacturer's written instructions and the following requirements:
 1. Remove all foreign material from joint substrates that could interfere with adhesion of joint sealant, including dust, paints (except for permanent, protective coatings tested and approved for sealant adhesion and compatibility by sealant manufacturer), old joint sealants, oil, grease, waterproofing, water repellents, water, surface dirt, and frost.
 2. Clean porous joint substrate surfaces by brushing, grinding, blast cleaning, mechanical abrading, or a combination of these methods to produce a clean, sound substrate capable of developing optimum bond with joint sealants. Remove loose particles remaining from above cleaning operations by

vacuuming or blowing out joints with oil-free compressed air. Porous joint surfaces include the following:

- a. Concrete.
- b. Masonry.
- c. Unglazed surfaces of ceramic tile.

3. Remove laitance and form-release agents from concrete.

- B. Joint Priming: Prime joint substrates where recommended in writing by joint sealant manufacturer, based on preconstruction joint-sealant-substrate tests or prior experience. Apply primer to comply with joint sealant manufacturer's written instructions. Confine primers to areas of joint-sealant bond; do not allow spillage or migration onto adjoining surfaces.
- C. Masking Tape: Use masking tape where required to prevent contact of sealant with adjoining surfaces that otherwise would be permanently stained or damaged by such contact or by cleaning methods required to remove sealant smears. Remove tape immediately after tooling without disturbing joint seal.

3.3 INSTALLATION OF JOINT SEALANTS

- A. General: Comply with joint sealant manufacturer's written installation instructions for products and applications indicated, unless more stringent requirements apply.
- B. Sealant Installation Standard: Comply with recommendations of ASTM C 1193 for use of joint sealants as applicable to materials, applications, and conditions indicated.
- C. Acoustical Sealant Application Standard: Comply with recommendations of ASTM C 919 for use of joint sealants in acoustical applications as applicable to materials, applications, and conditions indicated.
- D. Install sealant backings of type indicated to support sealants during application and at position required to produce cross-sectional shapes and depths of installed sealants relative to joint widths that allow optimum sealant movement capability.
- E. Install bond-breaker tape behind sealants where sealant backings are not used between sealants and back of joints.
- F. Install sealants by proven techniques to comply with the following and at the same time backings are installed:
 1. Place sealants so they directly contact and fully wet joint substrates.
 2. Completely fill recesses provided for each joint configuration.
 3. Produce uniform, cross-sectional shapes and depths relative to joint widths that allow optimum sealant movement capability.
- G. Tooling of Nonsag Sealants: Immediately after sealant application and before skinning or curing begins, tool sealants according to requirements specified below to form smooth, uniform beads of configuration indicated; to eliminate air pockets; and to ensure contact and adhesion of sealant with sides of joint.

1. Remove excess sealants from surfaces adjacent to joint.
2. Use tooling agents that are approved in writing by sealant manufacturer and that do not discolor sealants or adjacent surfaces.

3.4 CLEANING

- A. Clean off excess sealants or sealant smears adjacent to joints as the Work progresses by methods and with cleaning materials approved in writing by manufacturers of joint sealants and of products in which joints occur.

3.5 PROTECTION

- A. Protect joint sealants during and after curing period from contact with contaminating substances and from damage resulting from construction operations or other causes so sealants are without deterioration or damage at time of Substantial Completion. If, despite such protection, damage or deterioration occurs, cut out and remove damaged or deteriorated joint sealants immediately so installations with repaired areas are indistinguishable from the original work.

3.6 ELASTOMERIC JOINT-SEALANT SCHEDULE

- A. Multicomponent Nonsag Polysulfide Sealant: Where joint sealants of this type are indicated, provide products complying with the following:
 1. Products: Provide one of the following:
 - a. cm-60; W.R Meadows, Inc.
 - b. T-2235-M; Morton International, Inc.
 - c. T-2282; Morton International, Inc.
 - d. Thiokol 2P; Morton International, Inc.
 - e. GC-5 Synthacalk; Pecora Corporation.
 - f. Two-Part Sealant; Sonneborn Building Products Div., ChemRex Inc.
 2. Type and Grade: M (multicomponent) and NS (nonsag).
 3. Class: 25.
 4. Uses Related to Exposure: T (traffic)

3.7 LATEX JOINT-SEALANT SCHEDULE

- A. Latex Sealant: Where joint sealants of this type are indicated, provide products complying with the following:
 1. Products: Provide one of the following:
 - a. Chem-Calk 600; Bostik Inc.
 - b. NuFlex 330; NUCO Industries, Inc.
 - c. LC 160 All Purpose Acrylic Caulk; Ohio Sealants, Inc.
 - d. AC-20; Pecora Corporation.
 - e. PSI-701; Polymeric Systems, Inc.
 - f. Sonolac; Sonneborn Building Products Div., ChemRex, Inc.
 - g. Tremflex 834; Tremco.

3.8 ACOUSTICAL JOINT-SEALANT SCHEDULE

- A. Acoustical Sealant for Exposed and Concealed Joints: At all sound partitions and where joint sealants of this type are indicated, provide products complying with the following:
1. Products: Provide one of the following:
 - a. AC-20 FTR Acoustical and Insulation Sealant; Pecora Corporation.
 - b. SHEETROCK Acoustical Sealant; USG Corp., United States Gypsum Co.
- B. Acoustical Sealant for Concealed Joints: At all sound partitions and where joint sealants of this type are indicated, provide products complying with the following:
1. Products: Provide one of the following:
 - a. Pro-Series SC-170 Rubber Base Sound Sealant; Ohio Sealants, Inc.
 - b. BA-98; Pecora Corporation.
 - c. Tremco Acoustical Sealant; Tremco.

END OF SECTION

SECTION 08 11 13 – HOLLOW METAL DOORS AND FRAMES

PART 1 - GENERAL

1.1 SUMMARY

A. Work Included: Provide and install hollow metal doors and frames, complete, as shown on Drawings and as specified.

1. Hollow Metal Door and Frame Sets.
2. Hollow Metal Interior Window Frames.
3. Hollow Metal Frames for Wood Doors specified in Section 081416 – Flush Wood Doors.
4. Coordinate Door and Frame fabrication with door hardware specified in Section 087100 – Door Hardware as required for the hardware types scheduled on Drawings.
5. Coordinate Door and Frame fabrication with Security and Access Control products specified in DIVISION 26 – Electrical as required for Security and Fire Alarm wiring and interface.

B. Work Specified Elsewhere:

1. Section 050500 – Metal Fasteners.
2. Section 081416– Flush Wood Doors.
3. Section 084113– Aluminum Entrances and Storefronts.
4. Section 084213– Aluminum Framed Entrance
5. Section 087100 – Door Hardware.
7. Section 088000 –Glazing.
8. Section 085113 – Aluminum Windows.

1.2 REFERENCE STANDARDS

A. Hollow Metal Manufacturers Association (HMMA) Division of National Association of Architectural Metal Manufacturers (NAAMM):

1. Hollow Metal Manual; including HMMA 800, 801, 802, 810, 820, 830, 840, 841, 850, 860, 861, 862, 863, 880, 881, and 882.

1.3 QUALITY ASSURANCE

A. Comply with the latest edition of the following Standards:

1. National Fire Protection Association (NFPA):

- a. NFPA No. 80: "Fire Doors and Windows".
 - b. NFPA No. 251: "Fire Tests of Building Construction and Materials".
 - c. NFPA No. 252: "Fire Tests of Door Assemblies".
 - d. NFPA No. 257: "Fire Tests of Window Assemblies".
2. American Society for Testing and Materials (ASTM):
- a. ASTM E-119: "Methods for Fire Tests of Building Construction and Materials".
 - b. ASTM E-152: "Standard Methods of Fire Tests of Door Assemblies."
 - c. ASTM E-163: "Methods for Fire Tests of Window Assemblies".
3. American National Standards Institute (ANSI):
- a. A250.8: "Recommended Specifications for Standard Steel Doors and Frames".
4. Underwriters' Laboratories' (UL):
- a. UL-9: "Fire Tests of Door Assemblies".
 - b. UL-10C: "Fire Tests of Window Assemblies".
- B. Testing Agency Qualifications: Testing agency testing all fire rated doors and frames, shall have approval of enforcing authority for this project and provide inspection of materials and workmanship at factory during fabrication and assembly.
- C. Requirements of Regulatory Agencies: Where opening has fire resistive rating of 20 minutes or longer, door shall bear testing agency-issued label.
- a. Provide "T" temperature rating labels.

1.4 SUBMITTALS

- A. Comply with provisions of Section 013300 – Submittal Procedures.
- B. Product Data: Manufacturer's specifications, catalog cuts, data, and installation instructions.
- C. Shop Drawings:
 1. General: Show frame type, material descriptions and gauges, exact profiles, elevations, fire-resistive rating and complete details, including reinforcing, anchors, and connections.
 - a. Identify non-conforming frames and assemblies that cannot be

fire rated or labeled for Architect's review and direction.

2. Provide Elevation Drawings for each frame assembly, fully dimensioned and identified by numbering nomenclature used on Drawings, including:
 - a. Locations of rough-in and reinforcing preparation for hardware provided in other Sections.
 - b. Routing of electrical conduit or cable within frame members.
 - c. Glass Type for each Lite, incorporating nomenclature used on Drawings.
 - d. Locations of Doors, including swing and Door numbering nomenclature used on Drawings.
 - e. Frame Finish.
 3. Provide full-size special details showing thickness, profiles, jointing, connections, and assembly of various members, reinforcement, anchorage, and supports.
- D. Samples: Submit 12-inch by 12-inch "L" section of metal door frame showing corner detail, anchor, weld, and finish.
- E. Certificates: Submit certificates for specified doors and frames indicating compliance with fabrication and minimum labeling requirements. Certificates signed by Contractor and authorized representative of hollow metal manufacturing company.

1.6 PRODUCT HANDLING

- A. General: Deliver, store, and handle hollow metal work in manner to prevent damage, distortion, and deterioration.
- B. Packaging: Package hollow metal work in cardboard or other containers with separators, banding, spreaders, and paper wrappings to protect items during transit and Project site storage.
- C. Manufacturer's Recommendations: Follow special storage and handling requirements of manufacturer.
- D. Identification: Mark each door and door frame, on a surface which will be hidden after installation, with designation of opening for which it is furnished. Mark opening designation also on exterior packaging for each door and door frame.

1.7 COORDINATION

- A. Hardware Suppliers: Furnish hollow metal frame manufacturer with accepted hardware schedule, hardware templates, and samples of physical hardware where necessary to ensure correct fitting and installation.

PART 2 - PRODUCTS

2.1 MANUFACTURERS

- A. General: Provide products manufactured by Stiles Custom Metal, Inc; Curries Company, an ASSA ABLOY Group Company; Steelcraft, an Ingersoll Rand Company OR Ceco, an ASSA ABLOY Group Company

2.2 MATERIALS – GENERAL

A. Steel Sheet:

1. General: Free of scale, pitting, and surface defects.
2. Cold-Rolled: ASTM A366, commercial grade.
3. Hot-Rolled: ASTM A569, commercial grade, pickled.
4. Galvanized: Cold-rolled or hot-rolled sheet with zinc coating applied by hot-dip process per ASTM A526 (A60 or G60) with coating weight of not less than 0.30 ounces per square foot per side.

2.3 HOLLOW METAL DOORS

A. Faces:

1. Interior Doors: Cold-rolled or hot-rolled steel sheet; not less than 18 gauge.
2. Exterior Doors: Galvanized steel sheet, not less than 16 gauge.

B. Door Thickness: 1-3/4-inches, unless otherwise shown.

C. Door Types: Flush. Fully-welded seamless construction with no visible seams or joints on faces or vertical edges.

D. Door Construction:

1. General: Fabricate doors in conformance with ANSI A250.8, including:
 - a. Level and Physical Performance Level: Level 3 and Extra heavy Duty per ANSI A250.8.
 - b. Model: 2 (Seamless per ANSI A250.8).
2. Reinforcement: Stiffen face sheets by continuous vertical formed steel stiffener sections spanning full thickness of interior space between door faces.
3. Stiffeners: Not less than 22 gauge space not more than 6-inches apart and securely attach to face sheets by spot welds not more than 5-inches on center. Fill spaces between stiffeners to sound-deaden and

- insulate full height of door with an inorganic non-combustible batt-type material.
4. Door Faces: Join at vertical edges by continuous weld extending full height of door. Grind, fill, and dress welds smooth to make invisible and provide smooth flush surface.
 5. Top and Bottom Edges: Close with continuous recessed steel channel not less than 16 gauge, extending full width of door and spot welded to both faces. At exterior doors provide an additional flush closing channel at top edges and, where required for attachment of weather-stripping, a flush closure also at bottom edges. Provide openings in bottom closure of exterior doors to permit escape of entrapped moisture.
 6. Edge Profiles: Provide for both vertical edges of doors as follows:
 - a. Single-Acting Swing Doors: Bevel 1/8-inch in 2 inches.
 - b. Double-Acting Swing Doors: Round on 2-1/8-inch radius.
 7. Hardware Reinforcements:
 - a. General: Mortise, reinforce, drill and tap doors at factory for fully-templated hardware only, per hardware schedule and templates provided by hardware suppliers specified in Section 08710 – Door Hardware, and DIVISION 16 –Electrical (Fire Alarm and Security Requirements). Where surface-mounted hardware is scheduled, provide reinforcing plates only; drilling and tapping done by others.
 - b. Minimum Gauges For Hardware Reinforcing Plates: As follows:
 - 1) Hinge and Pivot Reinforcements: 7 gauge.
 - 2) Reinforcements for Lock Face, Flush Bolts, Concealed Holders: 12 gauge.
 - 3) Reinforcements for All Other Surface-Mounted Hardware: 16 gauge.
 8. Astragals:
 - a. Dutch Bend Astragal: Provide as integral part of door unless otherwise shown or scheduled. Fabricate astragal of three thickness of metal of same gauge as face sheet. Fabricate reveal on opposite door leaf from top to bottom for dutch bend astragal to lay flush with face.
 - b. Location:
 - 1) Exterior Pairs of Doors:
 - a) Outswing: Astragal on exterior side of active door leaf.

- b) Inswinging: Astragal on exterior side of inactive leaf.
9. Louvers: Welded blade type of construction. Louvers pierced into face sheets not permitted.
10. Exterior Doors: Provide weep-hole openings in bottom of exterior doors to permit moisture to escape. Seal joints in top edges of doors against water penetration.
- E. Electrical Requirements:
- 1. General: Make provisions for installation of electrical items specified under Section 087100 – Door Hardware, and DIVISION 16 –Electrical (Fire Alarm and Security Requirements) and other applicable Sections; arrange in manner so wiring can be readily removed and replaced.
 - 2. Doors with Electric Hardware:
 - a. General: Provide with metal raceway or conduit to permit wiring from electric hinge to other electric door hardware.
 - b. Hinges or Pivot Location: Center or intermediate as applicable; top or bottom not permitted.
 - c. Install Electro Lynx wiring and Molex type connectors. Furnished by Section 087100, Door Hardware.
- 2.4 HOLLOW METAL PANELS
- A. General: Fabricate and finish hollow metal panels as specified for hollow metal doors.
- 2.5 HOLLOW METAL FRAMES
- A. Materials:
 - 1. Interior Frames: Cold-rolled or hot-rolled steel sheet; not less than 16 gauge for openings 48-inches and less in width, and not less than 14 gauge for openings greater than 48-inches in width.
 - 2. Exterior Frames: Galvanized steel sheet; not less than 14 gauge.
 - B. Fabrication:
 - 1. General: Provide welded units with integral trim, of sizes and shapes shown. Knocked-down frames acceptable at interior non-rated openings only.
 - 2. Finished Work: Strong and rigid, neat in appearance, square, true and free of defects, warp or buckle. Fabricate molded members clean cut, straight and of uniform profile throughout their lengths.
 - 3. Jamb Depths, Trim, Profile, Returns, and Backbends: As shown.

4. Corner Joints: Close contact edges tight, miter and continuously weld trim edges, and miter (butt) stops. Use of gussets not permitted.
5. Stops: Minimum depth 5/8-inches.
6. Large Openings: When shipping limitations so dictate, fabricate frames for large openings in sections designed for splicing in field.
7. Multiple or Special Openings: Fabricate frames for multiple or special openings with mullion and/or rail members which are closed tubular shapes having no visible seams or joints. Securely weld joints between faces of abutting members and finish smooth.
8. Hardware Reinforcements:
 - a. General: Mortise, reinforce, drill, and tap frames at factory for fully templated mortised hardware only, per hardware schedule and templates provided by hardware supplier. Where surface-mounted hardware is to be applied, provide frames with reinforcing plates only.
 - b. Hardware Reinforcing Plates: Minimum thickness as follows:
 - 1) Hinge And Pivot Reinforcements: 7 gauge, 1-1/4-foot by 10-inches, minimum size.
 - 2) Strike Reinforcements: 12 gauge.
 - 3) Flush Bolt Reinforcements: 12 gauge.
 - 4) Closer Reinforcements: 12 gauge.
 - 5) Surface-Mounted Hardware Reinforcements: 12 gauge.
 - 6) Hold-Open Arm Reinforcements: 12 gauge.
 - 7) Surface Exit Device Reinforcements: 12 gauge.
9. Jamb Anchors:
 - a. Masonry Walls: Provide frames with adjustable jamb anchors. Anchors not less than 16-gauge steel or 0.156-inch diameter steel wire. Stirrup straps shall be not less than 2 inches by 10 inches in size, corrugated and/or perforated. Provide anchors on each jamb as follows:

Frames up to 7'-6" height:	3 anchors.
Frames 7'-6" to 8'-0" height:	4 anchors.
Frames over 8'-0" height:	1 anchor for each 2' or fraction thereof in height.

- b. Stud Partitions: Provide frames with steel anchors of suitable design, not less than 18-gauge thickness, securely welded inside each jamb as follows:
- | | |
|-------------------------------|---|
| Frames up to 7'-6" height: | 4 anchors. |
| Frames 7'-6" to 8'-0" height: | 5 anchors. |
| Frames over 8'-0" height: | 5 anchors plus one additional for each 2' or fraction thereof over 8'-0". |
- c. Previously Placed Concrete or Masonry: Provide frames to be anchored to previously placed concrete, masonry or structural steel with anchors of suitable design as shown on approved shop drawings.
10. Floor Anchors:
- a. General: Securely weld inside each jamb, with two holes provided at each jamb for floor anchorage.
- b. Adjustable Anchors: Where so scheduled or specified, provide adjustable floor anchors, not less than 2 inches in height adjustment.
- c. Thickness: Minimum 14 gauge.
11. Masonry Wall Openings More Than 48-Inches In Width: Provide with angle or channel stiffener factory welded into head; stiffeners not less than opening width and not used as lintels or load-bearing members.
12. Dust Cover Boxes: Or mortar guards, provide of not thinner than 26-gauge steel at hardware mortises on frames to be set in masonry or plaster partitions.
13. Steel Spreader: Provide frames with steel spreader temporarily attached to feet of both jambs to serve as brace during shipping and handling. Steel spreader not to be used for installation purposes.
- C. Electrical Requirements:
1. General: Make provisions for installation of electrical items specified under Section 087100 – Door Hardware, and DIVISION 26 –Electrical (Fire Alarm and Security Requirements) and other applicable Sections; arrange in manner so wiring can be readily removed and replaced.
2. Frames with Electric Hinges:
- a. General: Dust cover boxes or mortar guard for electrical hinges furnished under Section 087100 – Door Hardware; weld into place under this Section.
- b. Hinge or Pivot Location: Center or intermediate as applicable; top or bottom not permitted.

3. Back Box for Electrical Hardware Items: Furnished under Section 087100 – Door Hardware; weld into place under this Section.

2.6 FIRE-RATED DOORS AND FRAMES

- A. General: Provide labeled doors and frames for those openings requiring fire protection ratings as scheduled. Construct such doors and frames as tested and approved by UL, WHI, or other nationally recognized testing agency having factory inspection service.
- B. Non-Ratable Openings: Identify on Shop Drawings any door or frame scheduled to be fire-rated cannot qualify for appropriate labeling because of its design, hardware or any other reason. Do not begin fabrication for non-ratable items until all issues have been resolved.

2.7 STOPS AND MOLDINGS

- A. Moldings for Glazed Lites in Doors: Minimum 0.032 inch thick, fabricated from same material as door face sheet in which they are installed.
- B. Fixed Frame Moldings: Formed integral with standard steel frames, minimum 5/8 inch high, unless otherwise indicated.
- C. Loose Stops for Glazed Lites in Frames: Minimum 0.032 inch thick, fabricated from same material as frames in which they are installed.

2.8 SHOP PAINTING

- A. General: Comply with NAAMM's "Metal Finishes Manual for Architectural and Metal Products" for recommendations for applying and designating finishes.
 1. Finish standard steel door and frames after assembly.
- B. Galvanized Steel Surface Preparation: Clean surfaces with nonpetroleum solvent so surfaces are free of oil and other contaminants. After cleaning, apply a conversion coating suited to the organic coating to be applied over it. Clean welds, mechanical connections, and abraded areas, and apply galvanizing repair paint specified below to comply with ASTM A 780.
 1. Galvanizing Repair Paint: High-zinc-dust-content paint for reglazing welds in steel, complying with SSPC-Paint 20.
- C. Steel Surface Preparation: Clean surfaces to comply with SSPC-SP 1, "Solvent Cleaning"; remove dirt, oil, grease, or other contaminants that could impair paint bond. Remove mill scale and rust, if present, from uncoated steel; comply with SSPC-SP 3, "Power Tool Cleaning," or SSPC-SP 6/NACE No. 3, "Commercial Blast Cleaning."
- D. Factory Priming for Field-Painted Finish: Apply shop primer specified below immediately after surface preparation and pretreatment. Apply a smooth coat of even consistency to provide a uniform dry film thickness of not less than 0.7-mils.

- E. Shop Primer: Manufacturer's standard, fast-curing, lead- and chromate-free primer complying with ANSI A250.10 acceptance criteria; recommended by primer manufacturer for substrate; compatible with substrate and field-applied finish paint system indicated; and providing a sound foundation for field-applied topcoats despite prolonged exposure.

PART 3 - EXECUTION

3.1 EXAMINATION

- A. Verification of Conditions: Examine substrate and conditions under which hollow metal doors and frames are to be installed and give notification, in writing, of any conditions detrimental to proper and timely completion of work. Do not proceed with work until unsatisfactory conditions have been corrected.

3.2 INSTALLATION OF FRAMES

- A. General: Install frames per Reference Standards and as specified.
- B. Labeled Doors and Frames: Install per requirements of labeling authority.
- C. Setting: Exercise care in setting of frames to maintain scheduled dimensions, hold head level, and maintain jambs plumb and square.
- D. Anchorages and Connections: Secure to adjacent construction. Furnish anchors to suit wall conditions and floor angles or clips welded to frame for fastening to floor.
- E. Spreader Bars: Whenever possible, leave frame spreader bars intact until frames are set perfectly square and plumb and anchors are securely attached. Do not use shipping bars as spreaders.
- F. Expansion Movement: Allow for as required.
- G. Fire-Rated Frames: Install per NFPA Standard No. 80.
- H. Exterior Doors: Provide sheet metal drip at head.
- I. Frames in Metal Stud Partitions: Frames filled tight with mineral fiber safing as specified in Section 078413 – Penetration Firestopping.

3.3 SHOP COAT TOUCH-UP

- A. General: Immediately after installation remove rust, sand smooth, and touch-up items with prime coat which has been damaged with same primer as applied in shop.

3.4 ADJUSTMENT

- A. General: Replace or re-hang doors which are hinge-bound or do not swing or operate freely.

3.5 PROTECTION

- A. General: Protect installed work against damage from other construction work.

3.6 INSTALLATION OF DOORS

- A. General: Install doors per manufacturer's instructions.
- B. Hardware: Install per requirements specified in Section 087100 – Door Hardware.
- C. Adjustment: Adjust and lubricate operable parts as required for correct function.

END OF SECTION

SECTION 08 14 16- FLUSH WOOD DOORS

PART 1 - GENERAL

1.1 SUMMARY

- A. Work Included: Provide and install flush wood doors, complete, as shown on Drawings and as specified, including:
1. Flush Wood Doors, including: Wood Veneer Flush Doors, including specified veneer and transparent finish.
 2. Provide rated and un-rated doors as scheduled on Drawings.
 3. Coordinate Door fabrication with Section 087100 – Door Hardware as required for the hardware types scheduled on Drawings.
 4. Coordinate Door fabrication with DIVISION 26 – Electrical as required for Security and Fire Alarm wiring and interface.
- B. Work Specified Elsewhere:
1. Section 081113– Hollow Metal Doors and Frames.
 2. Section 084113–Aluminum Entrances and Storefronts.
 3. Section 087100 – Door Hardware.
 4. Section 088000 – Glazing.

1.2 REFERENCE STANDARDS

- A. National Wood Window and Door Association (NWWDA):
1. IS 1.1; General Requirements for Flush Wood Doors.
 2. IS 1.2; Solid Core Wood Flush Doors.
 3. IS 1.4; Special Construction Wood Flush Doors.
 4. IS 1.6; Testing and Inspection Requirements for Wood Flush Doors.
- B. Standards of Woodwork Institute (WI) "Manual of Millwork."
- C. American Society for Testing Materials (ASTM):
1. E-90-02: "Standard Test Method for Laboratory Measurement of Airborne Sound Transmission Loss of Building Partitions and Elements".

1.3 QUALITY ASSURANCE

A. Qualifications:

1. Manufacturer: Certified and licensed per NWWDA IS 1 Series.
2. United States Product Standard (PS) "Construction and Industrial Plywood" (PS 1-74).

1.4 SUBMITTALS

A. Comply with provisions of Section 013300 – Submittal Procedures.

B. Product Data: Manufacturer's specifications, catalog cuts, standard details, and installation details.

C. Shop Drawings: Complete, with door schedule; show location, types, sizes, thickness, cutout details, special details and other requirements to assure proper installation.

D. Samples:

1. Doors: Each type showing construction, faces, edges, and specified finishes; 12-inch by 12-inch corner section.

E. Certificates:

1. General: Certification that doors conform to NWMA IS 1 Series.
2. Sound Retardant Doors: Certification that doors comply with specified STC rating.

1.5 EXTENDED WARRANTY

A. Comply with requirements of Section 017600 – Guarantees and Warranties.

B. General: Manufacturer's standard based on NWMA IS 1.1 tolerances and book sizes.

C. Solid Core Doors:

1. Interior: Life of original installation.

1.6 PRODUCT HANDLING

A. Delivery: Package doors per manufacturer's recommendation prior to shipment. Mark and identify doors for each opening to facilitate proper location.

B. Storage: Store doors flat on level surfaces in clean, dry, and properly ventilated spaces.

PART 2 - PRODUCTS

2.1 MANUFACTURERS

- A. Typical Flush Wood Doors: Provide wood doors manufactured by Marshfield Door Systems, VT Industries, Eggers Industries, or Oshkosh Architectural Wood Doors
- B. Basis of Design: VT Industries.

2.2 WOOD VENEER FACES FOR TRANSPARENT FINISH

A. General:

- 1. Provide wood veneer faced flush wood doors as required to match the Architect's samples and in conformance with ANSI/HPVA HP-1; not less than 1/50-inch-thick before finish sanding.
 - a. Grade: Premium, with Grade AA faces.

B.

- 1. Species: **Select Cherry.**
- 2. Cut: **Quarter Sawn (Straight Grain), No Sapwood**
- 3. Veneer Match: **Book Match**
- 4. Veneer Face Assembly: **Running Match**
- 3. Application:
 - a. Face Panel Grade: HPVA Grade AA.
 - b. Finish: **Finish to match doors in this building (Budge Clinic).**
- 4. Match between veneer leaves: **Book Match**
- 5. Fabrication: As specified in this Section.

2.3 MDO FACES FOR SHOP AND FIELD PAINTING

- A. Paint-Grade Medium Density Overlay (MDO): Conform to PS 1-74.
- B. Paint doors as specified in Section 099123 – Interior Painting.

2.4 FABRICATION – NON-RATED DOORS AND 20-MINUTE RATED DOORS

- A. Fabrication:
 - 1. General: Per NWWDA IS 1 Series, Premium Grade; no finger jointing permitted.
- B. Cores:
 - 1. Particleboard: Mat-formed wood particle board per ANSI 208.1, Grade 1-L-2 28–32 pounds per cubic foot.
 - a. Use particleboard made with binder containing no urea-formaldehyde resin.
 - 2. Blocking: Provide mill option wood blocking in particleboard-core doors as required to eliminate through-bolting hardware for all surface applied hardware.
 - 3. Adhesive: Type I bond.
 - 4. Bonding: Fabricate doors using bonded core construction, including stile and rails bonded to core, using adhesive and pressure during the curing process. Plane assembled and cured door core units to a uniform thickness prior to application of crossbanding and veneers.
 - 5. Crossbands: Dried to 6-9 percent moisture content, minimum 1/16-inch-thick spliced hardwood with no voids or defects, extending full width of doors with grain at right angles to face veneer.
 - 6. Stiles: Provide SCL stiles, minimum 1-3/8-inch-thick before fitting; 1-1/8-inch minimum after trimming. For wood veneer doors, provide outer band matching specified wood veneer, with no exposed crossbands.
 - 7. Rails: Provide wood rails, 1-1/8-inch minimum after trimming; mill option hardwood or softwood of a density equal to or exceeding Douglas Fir.
 - 8. 20 minute particle core shall meet positive pressure and "S" label without use of intumescent seals.
- C. Identification: Stamp each door with NWWDA Certification Hallmark.
 - 1. 20-Minute Fire Rated Doors: Provide each door with UL or WHI metal or mylar type labels.

2.6 FABRICATION – 45, 60 AND 90 MINUTE FIRE RATED DOORS

- A. Fabrication:
 - 1. General: Fabricate as specified for standard doors, NWWDA IS 1.4, and UL requirements for fire rating shown.
 - 2. Non-Ratable Openings: If any scheduled fire rated door cannot be labeled because of design, size, hardware, or other reason, give written notification; do not start fabrication until conflict is resolved.

- B. Core: Door manufacturer's standard non-combustible mineral core, containing 0-percent asbestos and designed to meet or exceed labeling requirements.
 - 1. Concealed Rod Hardware: Where scheduled, provide Georgia-Pacific, or equal, Firestop components; including matching full length wood edge meeting stiles with no visible finger joints, 1/2-inch width after trimming. Metal edges or metal edge and astragal no acceptable.
 - 2. Reinforcement: Manufacturer's standard size, incombustible multi-ply inner blocking to eliminate through-bolting of surface mounted hardware.
 - a. Stile Edge Screw Withdrawal: Minimum 740-pounds when tested per ASTM D-1037.
 - 3. Stile Edge Split Resistance: Minimum 750-pounds minimum when tested per ASTM D-143 (modified). For wood veneer doors, provide 1/2-inch-thick outer band matching specified wood veneer.
 - a. Reinforce hinge edge on all fire doors to accommodate full-mortise hinges as specified and to provide additional screw holding power when hinge is installed.
- C. Cross Bands and Edge Bands: Untreated or fire retardant treated per UL requirements for fire rating shown.
- D. Identification: Stamp each door with NWWDA Certification Hallmark.
 - 1. Fire Rated Doors: Provide each door with UL or WHI metal or mylar type labels.
- E. Install flush stainless steel edge guards under label procedure. Furnished by section 087100 – Door Hardware.
- F. Install Electro Lynx wiring and Molex. Type connectors under label procedure. Furnished by section 087100 – Door Hardware.

2.7 VISION PANEL FRAMES

- A. General: Provide where shown; square profile moldings, unless otherwise shown.
- B. Standard Doors:
 - 1. General: Solid stock hardwood; flush type, unless otherwise shown.
 - 2. Transparent Finish: Same grade and species to match face.
- C. Glazing Materials: Provided under Section 088000 – Glazing.

2.8 GLASS AND GLAZING

- A. Vision Glass: Rated and Non-rated vision glass specified in Section 088000 – Glazing.

2.9 SIZES AND CLEARANCES

- A. Sizes: As shown; coordinate with installation to determine actual door sizes and clearances.
 - 1. Door Thickness: 1-3/4-inch, unless otherwise shown.
- B. Clearances: Maximum 1/8-inch clearance at jambs, heads, and meeting stiles; maximum 1/4-inch clearance over thresholds, and maximum 3/8-inch clearance in openings without thresholds; unless otherwise shown. Bevel vertical edges 1/8-inch per 2 inches.

2.10 PRE-FITTING AND PREMACHINING

- A. General: Pre-fit and pre-machine.
- B. Pre-fitting: Pre-fit at factory per specified clearances. Provide stile edges with standard bevel or radius as required by hardware.
- C. Pre-machining: Coordinate with Section 087100 – Door Hardware, and DIVISION 26 - Electrical Security Requirements, including:
 - 1. Factory machine doors for hardware that is not surface applied. Locate hardware to comply with DHI-WDHS-3. Comply with final hardware schedules, door frame Shop Drawings, DHI A115-W Series standards, and hardware templates.
 - 2. Coordinate measurements of hardware mortises in metal frames to verify dimensions and alignment before factory machining.

2.11 PRESEALING FOR PAINTED FINISHES

- A. Opaque Finished Doors:
 - 1. General: Manufacturer's standard clear sealer or pigmented alkyd base primer sealer; verify compatibility with Section 099123 – Interior Painting.
 - 2. Sealer or Primer Sealer: One coat; apply to top and bottom rails and hardware cutouts.
 - 3. Opaque Finish: Shop or Field Paint as shown on Drawings and as specified in Section 099123 – Interior Painting.

PART 3 - EXECUTION

3.1 PREPARATION

- A. General: Do not install doors until cementitious work in areas shown to receive wood doors is completed and dry.
- B. Environmental Requirements: Condition doors to normal occupancy conditions prior to hanging. Do not subject doors to abnormal heat, dryness, or humidity.
- D. Examine doors and substrates, with Installer present, for suitable conditions where wood doors will be installed.
 - 1. Verify that installed frames comply with indicated requirements for type, size, location, and swing characteristics and have been installed with plumb jambs and level heads.
 - 2. Reject doors with defects.
 - 3. Proceed with installation only after unsatisfactory conditions have been corrected.

3.2 INSTALLATION

- A. General: Cut, trim, and hang doors to fit into frames with specified clearances. Recoat top and bottom edges prior to hanging, if affected by fitting; use same type paint as applied at factory.
- B. Prefinished Doors: Cutting, trimming, fitting, and machining not permitted.
- C. Operation: Rehang or replace doors that do not swing or operate freely.
- E. Finished Doors: Replace doors that are damaged or do not comply with requirements. Doors may be repaired or refinished if work complies with requirements and shows no evidence of repair or refinishing.

END OF SECTION

SECTION 08 31 13 – ACCESS PANELS

PART 1 - GENERAL

1.1 SUMMARY

- A. Work Included: Provide and install access panels, complete, as shown on Drawings as specified, and if not shown on Drawings, as required to access mechanical, electrical, plumbing and other equipment in conformance with governing codes and workplace safety guidelines.

1. Ceiling-mounted access panels.

- B. Work Specified Elsewhere:

1. Section 092216 – Non-Structural Metal framing
2. Section 092900 - Gypsum Board.
4. Section 099123 – Interior Painting.

1.2 SUBMITTALS

- A. Conform to the requirements of Section 013300 – Submittal Requirements.
- B. Product Data: Submit manufacturer's specifications, catalog cuts, and installation instructions. Submit approved test data or State Fire Marshal listing for fire-rated assemblies.
- C. Shop Drawings: Show attachment to partition, soffit, and ceiling framing at each typical condition.

1.3 PRODUCT HANDLING

- A. Delivery and Storage: Deliver and store panels in manufacturer's standard protective packaging.
- B. Protection: Do not remove protective packaging until time of installation.

PART 2 - PRODUCTS

2.1 ACCESS PANELS FOR CEILINGS

1. Glass Fiber Reinforced Gypsum (GFRG) Type 1:

1. Manufacturer: Bauco Access Panel Solutions Inc.

- A. baucoplus-II series: Non-rated recessed access doors with concealed hardware and gypsum board inlay for flush installation.

- B. Material Overview: Extruded aluminum alloy 6063-T6 frames and supports complete

with 5/8" (15.9 mm) or 1/2" (12.7 mm) moisture and mold resistant gypsum board inlay and galvanized internal steel corner reinforcing. Zinc-plated hardened steel screws, free pivot hinge, safety cable with carabineer hook, vinyl screw caps, and EPDM rubber gaskets.

C. Door: Fabricate using 2.8 mm thick extruded aluminum alloy 6063-T6 frame, screwed in place gypsum board inlay complete with galvanized internal steel corner reinforcing. Exposed top edge of frames shall have a concave meniscus rise to 0.5mm thick to accept finishing compound allowing a near invisible flush frame finish.

D. Frame: Recessed aluminum frame shall provide an edge similar to drywall bead against which the ceiling or wall surface shall be finished allowing a near invisible flush frame finish. Fabricate using 2.8mm thick extruded aluminum alloy 6063-T6 frame, complete with galvanized internal steel corner reinforcing. Frame opening complete with perimeter EPDM gasket maintaining the STC of gypsum board assembly.
Frame model specification:
BPII 58 - for 5/8 board

E. Board: Access Panel inlay shall equal the wall & ceiling specifications to ensure acoustic integrity.
Board Inlay specification:
baucoplus-II moisture and mold resistant gypsum board inlay

F. Hinge Detail: Concealed, galvanized steel free pivot hinge shall allow all doors to open 120 degrees. All access panel doors shall be fully removable and complete with a safety cable to secure doors to panel frames with a safety cable, test rated for 135lb (61kg), nylon coated, with crimp connections and spring snap aluminum carabiner.

G. Hinge Location:
baucoplus-II panels for ceiling installation will be hinged on the longest side unless specified. When baucoplus-II panels are used in a wall installation, the hinges must be located on the floor side. The last 2 digits of the product code will always be the hinge location, and always the horizontal measurement for a wall installation.

H. Latching/Locking devices:
Concealed touch latch – standard

I. Finish: baucoplus-II series access panels require finishing using common trade tools. For best results, setting-type gypsum finishing compound is recommended. Apply compound separately to the door leaf and surrounding wall or ceiling area up to recessed access panel frame. No taping required. Door shall receive the same finish and paint as the surrounding surfaces. When installed and finished the access panel shall be completely flush with the wall or ceiling surface and only a one sixteenth of an inch shadow gap shall be visible.

J. General Access Panel Dimensions For 5/8" Gypsum board:
baucoplus-II series shall come in the following standard sizes:

Size: 24" x 24"

Model Number: 20-58-2424

Description: 24" x 24" (610mm x 610mm) baucoplus II access panel, 5/8" gypsum inlay, non-rated, concealed touch latch, free pivot hinge

N. Access Panel Sizing: baucoplus-II dimensions in model number refer to clear opening in door.

O. Framing: For a proper fit between framing members the rough framed opening will be 2 1/2" greater than product code sizing. This 2 1/2" allowance provides the door frame size 1 1/8" plus 1/8" allowance on all sides of the panel.

P. FABRICATION

- A. Manufacture each access panel assembly as an integral unit ready for site installation.
- B. Furnish number of latches required to hold door flush for a smooth uniform panel appearance when closed.
- C. Larger sizes bracing will be added to add rigidity and/or prevent sagging.
- D. Supply rear of panel door with acoustic treatment when specified.
- E. Provide installation instructions with each panel.
- F. Rear of panel door leaf label indicating product model and size

EXECUTION

Q. EXAMINATION

A. Examine areas to receive access doors. Notify Architect if areas are not acceptable. Do not begin installation until unacceptable conditions have been corrected.

R. PREPARATION

A. Advise installers of work relating to access panel installation including rough opening dimensions, locations of supports, and anchoring methods. Coordinate delivery with other work to avoid delay.

S. INSTALLATION

- A. Follow manufacturer's instructions for installing access panels. Install access doors plumb, level, and square.
- B. Anchor frames securely in place.
- C. Set frames to proper alignment with the wall or ceiling.
- D. Position access panels for proper access to concealed equipment requiring access.

T. ADJUST AND CLEAN

- A. Adjust panel after installation for proper operation. Remove drywall compound from hinge, frame and door leaf edge. Clean the frame and door with a damp cloth.
 - B. Remove and replace panels or frames that are warped, bowed, or damaged.

2. Metal Types:

- 1. Manufacturers: Karp Associates, Inc., Larsen's Manufacturing Co., Milcor, Nystrom, Inc., JL Industries, or equal. Karp specified as standard.
- 2. Non-Rated Gypsum Board Partitions: Karp Type KDW, flush panel type with frame flanges for joint compound concealment, 16-gauge steel frames and 14-gauge steel doors.
- 3. Fire-Rated Gypsum Board Partitions: Karp Type KRP-250FR, 16-gauge steel doors and frames. Provide UL label.
- 4. Exterior Cement Plaster Soffits: Karp Type DSC-210 PL; frame of 13-gauge and door of 16-gauge galvanized steel finished with baked enamel, recessed, and lined with galvanized self-furring steel lath. Provide concealed pivoting rod hinge and key-operated stainless

steel lock.

2.2 MISCELLANEOUS MATERIALS

- A. General: Provide fastening devices, masonry anchors, casing beads, and other items as required to secure door and frame in place.

PART 3 - EXECUTION

3.1 EXAMINATION

- A. Verification of Conditions: Examine construction to receive access panels and verify correctness of dimensions and other supporting or adjoining conditions. Do not install panels until unsatisfactory conditions have been corrected. Verify that locations serve portion of work to which access is required.

3.2 INSTALLATION

- A. General: Install, per manufacturer's recommendations, securely to framing in locations required to give access to plumbing, mechanical, electrical, or similar devices concealed in walls or ceilings.
- B. GFRG Access Panels: Conceal joint between GFRG frame and gypsum board with tape and joint compound as specified under Section 092900.
- C. Coordination: Coordinate with other trades to verify correct sizes and locations of access panels.

3.3 ADJUSTMENT

- A. General: Following installation, adjust access panels for smooth operation.

3.4 CLEANING

- A. General: Thoroughly clean surface of grease, oil, or other impurities, touch up abraded prime coats and otherwise prepare for finish painting.

END OF SECTION

SECTION 08 33 00 - ROLLING GRILLES – OPEN DESIGN**PART 1 GENERAL**

1.1 SUMMARY

- A. **Section Includes:** Electric operated overhead rolling grilles.
- B. **Related Sections:**
1. 05 50 00 Metal Fabrications. Door opening jamb and head members.
 2. 06 10 00 Rough Carpentry. Door opening jamb and head members.
 3. 08 31 00 Access Doors and Panels. Access doors.
 4. 08 70 00 Hardware. Masterkeyed cylinders.
 5. Division 26. Electrical wiring and conduit, fuses, disconnect switches, connection of operator to power supply, and installation of control station and wiring.
- C. **Products That May Be Supplied, But Are Not Installed Under This Section:**
1. Control station.
 2. Manual release pull handle.

1.2 SYSTEM DESCRIPTION

- A. **Design Requirements:**
1. **Cycle Life:**
 - a. Design grilles of standard construction for normal use of up to 5 cycles per day maximum, and an overall maximum of 50,000 operating cycles for the life of the grille.
 - a. Design grilles of special construction for high cycle use. Expected cycles of up to 10 per day.
 2. **Safety:**
 - a. Chain operated doors shall be designed so that the door immediately stops upward or downward travel and is maintained in a stationary position when the hand chain is released by user.

1.3 SUBMITTALS

- A. **Reference Section 01 33 00 Submittal Procedures; submit the following items:**
1. **Product Data.**
 2. **Shop Drawings:** Include special conditions not detailed in Product Data. interface with adjacent work.
 3. **Quality Assurance/Control Submittals:**
 - a. Provide proof of manufacturer ISO 9001:2015 registration.
 - b. Provide proof of manufacturer and installer qualifications - see 1.3 below.
 - c. Provide manufacturer's installation instructions.
 4. **Closeout Submittals:**
 - a. Operation and Maintenance Manual.
 - b. Certificate stating that installed materials comply with this

specification.

1.4 QUALITY ASSURANCE

- A. **Qualifications:**
 - 1. **Manufacturer Qualifications:** ISO 9001:2015 registered and a minimum of five years experience in producing grilles of the type specified.
 - 2. **Installer Qualifications:** Manufacturer's approval.

1.5 DELIVERY STORAGE AND HANDLING

- A. Reference Section 01 66 00 Product Storage and Handling Requirements.
- B. Follow manufacturer's instructions.

1.6 WARRANTY

- A. **Standard Warranty:** Two years from date of shipment against defects in material and workmanship.
- B. **Maintenance:** Submit for owner's consideration and acceptance of a maintenance service agreement for installed products.

PART 2 PRODUCTS

2.1 MANUFACTURER

- A. **Manufacturer:** Cornell - 24 Elmwood Ave. Mountain Top, PA 18707. Telephone: (800) 233-8366. Underwriters Laboratories, Inc. (UL), ISO 9001:2008 Registered.
- B. **Model:** ESG10
- C. **Approved Equal:** Cookson - 1901 South Litchfield Rd, Goodyear, AZ, 85338. Telephone: (800) 294-4358.
- D. **Substitutions:** Reference Section 01 25 13 Product Substitution Procedures.

2.2 MATERIALS

- A. **Curtain:**
 - 1. **ESG10 Straight Pattern**
 - a. **Horizontal Rods:** Solid 5/16 inch (8 mm) diameter, AISI 300 series stainless steel
 - 1. **Vertical Spacing:** 2 inches (50.8 mm) on center.
 - b. **Vertical Chains:** Grommetted stainless steel links, 3/4 inch (19 mm) wide, positioned by E-rings on 3 inch (76.2 mm) centers. Provide double E-rings on horizontal bars on both sides of end chains to retain curtain in guides.

2. **Bottom Bar:** 2 x 3-1/2 inch (50.8 x 88.9 mm) extruded aluminum tubular section reinforced with 3 x 2 x 3/16 inch (76.2 x 50.8 x 4.76 mm) aluminum angle(s).
3. **Finish:**
 - a. **Stainless Steel Curtain with Stainless Steel Bottom Bar:** Factory polished.
- B. **Guides, Tube Mounted:** Heavy duty extruded aluminum sections with snap-on cover to conceal fasteners and polypropylene pile runners on both sides of curtain. Provide aluminum tubes, floor saddles and hardware as recommended by manufacturer to support grille.
 1. **Finish, Aluminum Guide Components:**
 - a. Clear anodized
- C. **Counterbalance Shaft Assembly:**
 1. **Barrel:** Steel pipe capable of supporting curtain load with maximum deflection of 0.03 inches per foot (2.5 mm per meter) of width.
 2. **Spring Balance:** Oil-tempered, heat-treated steel helical torsion spring assembly designed for proper balance of grille to ensure that maximum effort to operate will not exceed 25 lbs (110 N). Provide wheel for applying and adjusting spring torque.
- D. **Brackets:** Fabricate from minimum 3/16 inch (4.76 mm) steel plate with permanently lubricated ball or roller bearings at rotating support points to support counterbalance shaft assembly and form end closures.
 1. **Finish:**
 - a. Zirconium treatment followed by a light gray baked-on polyester powder coat; minimum 2.5 mils (0.065 mm) cured film thickness.
 - a. Zirconium treatment followed by a corrosion inhibitive baked-on zinc-rich gray polyester powder coat; minimum 2.5 mils (0.065 mm) cured film thickness.
 - a. ASTM A 123, Grade 85 zinc coating, hot-dip galvanized after fabrication.
- E. **Hood and Fascia:** 24 gauge stainless steel with reinforced top and bottom edges. Provide minimum 1/4 inch (6.35 mm) steel intermediate support brackets as required to prevent excessive sag.
 1. **Finish:**
 - a. **Stainless Steel:** No. 4 finish.

2.3 ACCESSORIES

A. Locking:

1. **Motor Operated:** Keyed cylinder locking into both jambs operable from both sides of curtain with motor interlock cutout switches.
- B. **Emergency Egress System:** Provide wall mounted manual release system pull handle to disengage motor operator and automatically open grille for emergency egress without the use of electrical power. Release of pull handle will reset grille to normal motor operation.
- C. **Operator and Bracket Mechanism Cover:** Provide 24 gauge stainless steel sheet metal cover to enclose exposed moving operating components at coil area of unit. Finish to match door hood.

2.4 OPERATION

- A. **Supply Model SG Electric Motor Operator, continuous duty**, cULus listed, Totally Enclosed Fan Cooled gear head operator(s) rated (1/2) to (7 1/2) hp as recommended by door manufacture for size and type of door, ___Volts, ___Phase. Provide complete with electric motor and factory pre-wired motor control terminals, maintenance free solenoid actuated brake, emergency manual chain hoist provided up to 2 hp and control station(s). Motor shall be high starting torque, industrial type, with overload protection. Primary speed reduction shall be heavy-duty gears running in grease or oil bath with mechanical braking to hold the door in any position. When equipped, the emergency manual chain hoist assembly is automatically disengaged when motor is energized. A disconnect chain shall not be required to engage or release the manual chain hoist. Operator drive and door driven sprockets shall be provided with minimum #50 roller chain. Operator shall be capable of driving the door at a speed of 6 to 9 inches per second (15 to 23 cm/sec). Fully adjustable, driven linear screw type cam limit switch mechanism shall synchronize the operator with the door. The motor shall be removable without affecting the limit switch settings. The electrical contractor shall mount the control station(s) and supply the appropriate disconnect switch, all conduit and wiring per the overhead door wiring instructions.
 1. **Control Station:** Flush mounted, "Open/Close" key switch with "Stop" push button; NEMA 1B.
- B. Provide operator to function with constant pressure close operation to meet UL325-2010 listing standard requirements.
 1. **Provide a continuously monitored, wireless sensing/weather edge seal** extending full width of door bottom bar. Contact before door fully closes shall cause door to immediately stop downward travel and reverse direction to the fully opened position.
 - 1.

- C. **Sensing/Weather Edge:** Provide automatic reversing control by an automatic sensing switch within neoprene or rubber astragal extending full width of grille bottom bar.
 - 1. Provide an electric sensing edge device. Contact before grille fully closes shall cause door to immediately stop downward travel and reverse direction to the fully opened position. Provide a wireless sensing edge connection to motor operator eliminating the need for a physical traveling electric cord connection between bottom bar sensing edge device and motor operator.

PART 3 EXECUTION

3.1 EXAMINATION

- A. Examine substrates upon which work will be installed and verify conditions are in accordance with approved shop drawings.
- B. Coordinate with responsible entity to perform corrective work on unsatisfactory substrates.
- C. Commencement of work by installer is acceptance of substrate.

3.2 INSTALLATION

- A. General: Install grille and operating equipment with necessary hardware, anchors, inserts, hangers and supports.
- B. Follow manufacturer's installation instructions.

3.3 ADJUSTING

- A. Following completion of installation, including related work by others, lubricate, test, and adjust grilles for ease of operation, free from warp, twist, or distortion.

3.4 CLEANING

- A. Clean surfaces soiled by work as recommended by manufacturer.
- B. Remove surplus materials and debris from the site.

3.5 DEMONSTRATION

- A. Demonstrate proper operation to Owner's Representative.
- B. Instruct Owner's Representative in maintenance procedures.

END OF SECTION

SECTION 08 41 00 – ALUMINUM ENTRANCES AND STOREFRONTS

PART 1 - GENERAL

1.1 RELATED DOCUMENTS

- A. Drawings and general provisions of Contract, including General and Supplementary Conditions and Division 1 Specification Sections, apply to this Section.

1.2 SUMMARY

- A. This Section includes the following types of aluminum entrance and storefront work:
 - 1. Interior windows.
 - 2. Interior partitions.
- B. Related Sections: The following sections contain requirements that relate to this Section:
 - 1. Section 079200 "Joint Sealants" for sealing between storefront system and the substrate.
 - 2. Section 088000 "Glazing" for requirements for aluminum entrances and storefront, including entrances specified to be factory glazed and fire rated openings.

1.3 SYSTEM PERFORMANCE REQUIREMENTS

- A. General: Provide aluminum entrance and storefront assemblies that comply with performance characteristics specified, as demonstrated by testing the manufacturer's corresponding stock assemblies according to test methods indicated.
- C. Structural Performance: Conduct tests for structural performance in accordance with ASTM E 330. At the conclusion of the tests there shall be no glass breakage or permanent damage to fasteners, anchors, hardware or actuating mechanism. Framing members shall have no permanent deformation in excess of 0.2 percent of their clear span.
 - 1. Deflection Normal to the Plane of the Wall: Test pressure required to measure deflection of framing members normal to the plane of the wall shall be equivalent to the wind load specified above. Deflection shall not exceed 1/175 of the clear span, when subjected to uniform load deflection test.
 - 2. Deflection Parallel to the Plane of the Wall: Test pressures required to measure deflection parallel to the plane of the wall shall be equal to 1.5 times the wind pressures specified above. Deflection of any member carrying its full dead load shall not exceed an amount that will reduce glass bite below 75 percent of the design dimension and shall not reduce the edge clearance between the member and the fixed panel, glass or other

fixed member above to less than 1/8 inch. The clearance between the member and an operable door or window shall be at least 1/16 inch.

1.4 SUBMITTALS

- A. General: Submit the following in accordance with Conditions of the Contract and Division 1 Specification Sections.
- B. Product Data: Product data for each aluminum entrance and storefront system required, including:
 - 1. Manufacturer's standard details and fabrication methods.
 - 2. Data on finishing, hardware and accessories.
 - 3. Recommendations for maintenance and cleaning of exterior surfaces.
- D. Shop Drawings: Shop drawings for each aluminum entrance and storefront system required, including:
 - 1. Layout and installation details, including relationship to adjacent work.
 - 2. Elevations at 1/4-inch scale.
 - 3. Detail sections of typical composite members.
 - 4. Anchors and reinforcement.
 - 5. Hardware mounting heights.
 - 6. Provisions for expansion and contraction.
 - 7. Glazing details.
- E. Hardware Schedule: Submit complete hardware schedule organized into sets based on hardware specified. Coordinate hardware with doors, frames, and related work to ensure proper size, thickness, hand, function, and finish. Include item name, name of the manufacturer and complete designations of every item required for each door opening.
- F. Samples for Color Selection: Submit pairs of samples of each specified color and finish on 12-inch-long sections of extrusions or formed shapes. Where normal color variations are anticipated, include 2 or more units in each set of samples indicating extreme limits of color variations.
- G. Test Reports: Provide certified test reports from a qualified independent testing laboratory showing that aluminum entrance and storefront systems have been tested in accordance with specified test procedures and comply with performance characteristics indicated.

1.5 QUALITY ASSURANCE

- A. Installer Qualifications: Engage an experienced Installer who has completed installations of aluminum storefront and entrances similar in design and extent to those required for the project and whose work has resulted in construction with a record of successful in-service performance.
- B. Manufacturer's Qualifications: Provide aluminum entrances and storefront systems produced by a firm experienced in manufacturing systems that are similar to those indicated for this project and that have a record of successful in-service performance.

- C. Single Source Responsibility: Obtain aluminum entrance and storefront systems from one source and from a single manufacturer.
 - D. Design Criteria: The drawings indicate the size, profile, and dimensional requirements of aluminum entrance and storefront work required and are based on the specific types and models indicated. Aluminum entrance and storefront by other manufacturers may be considered, provided deviations in dimensions and profiles are minor and do not change the design concept as judged by the Architect. The burden of proof of equality is on the proposer.
 - E. Pre-installation Conference: Conduct conference at Project site to comply with requirements in Division 1 Section "Project Management and Coordination." Review methods and procedures related to aluminum windows including, but not limited to, the following:
 - 1. Inspect and discuss condition of substrate and other preparatory work performed by other trades.
 - 2. Review and finalize construction schedule and verify availability of materials, Installer's personnel, equipment, and facilities needed to make progress and avoid delays.
 - 3. Review required testing and inspecting procedures.
 - 4. Review hardware requirements and installation procedures.
- 1.6 DELIVERY, STORAGE, AND HANDLING
- A. Deliver aluminum entrance and storefront components in the manufacturer's original protective packaging.
 - B. Store aluminum components in a clean dry location away from uncured masonry or concrete. Cover components with waterproof paper, tarpaulin or polyethylene sheeting in a manner to permit circulation of air.
 - 1. Stack framing components in a manner that will prevent bending and avoid significant or permanent damage.
- 1.7 PROJECT CONDITIONS
- A. Field Measurements: Check openings by accurate field measurement before fabrication. Show recorded measurements on shop drawings. Coordinate fabrication schedule with construction progress to avoid delay of the work
 - 1. Where necessary, proceed with fabrication without field measurements, and coordinate fabrication tolerances to ensure proper fit.
- 1.8 WARRANTY
- A. Special Assembly Warranty: Manufacturer's standard form in which manufacturer agrees to repair or replace components of aluminum-framed systems that do not comply with requirements or that deteriorate as defined in this Section within specified warranty period.
 - 1. Failures include, but are not limited to, the following.
 - a. Structural failures including, but not limited to, excessive deflection.
 - b. Noise or vibration caused by thermal movements.

- c. Deterioration of metals, metal finishes, and other materials beyond normal weathering.
 - d. Water leakage through fixed glazing and framing areas.
 - e. Failure of operating components to function properly.
 - f. Warranty Period: Five years from date of Substantial Completion.
2. Special Finish Warranty: Manufacturer's standard form in which manufacturer agrees to repair or replace components on which finishes fail within specified warranty period. Warranty does not include normal weathering.
- a. Warranty Period: 2 years from date of Substantial Completion.

PART 2 - PRODUCTS

2.1 MANUFACTURERS

- A. Available Manufacturers - Standard Systems: Subject to compliance with requirements, manufacturers offering entrance and storefront systems that may be incorporated in the work include the following:
 - 1. Kawneer North America, an Alcoa Company.
 - 2. C.R. Laurence - US Aluminum Corp.
 - 3. EFCO Corporation, a Pella Company.
 - 4. Oldcastle BuildingEnvelope Corporation

2.2 MATERIALS

- A. Aluminum Members: Alloy and temper recommended by the manufacturer for strength, corrosion resistance, and application of required finish; comply with ASTM B 221 for aluminum extrusions, ASTM B 209 for aluminum sheet or plate, and ASTM B 211 for aluminum bars, rods and wire.
- B. Carbon Steel: Carbon steel reinforcement of aluminum framing members shall comply with ASTM A 36 for structural shapes, plates and bars, ASTM A 611 for cold rolled sheet and strip, or ASTM A 570 for hot rolled sheet and strip.
- C. Glass and Glazing Materials: Comply with requirements of "Glass and Glazing" section of these specifications.
- D. Fasteners: Provide fasteners of aluminum, nonmagnetic stainless steel, zinc plated steel, or other material warranted by the manufacturer to be noncorrosive and compatible with aluminum components, hardware, anchors and other components.
 - 1. Reinforcement: Where fasteners screw-anchor into aluminum members less than 0.125 inches thick, reinforce the interior with aluminum or nonmagnetic stainless steel to receive screw threads, or provide standard noncorrosive pressed-in splined grommet nuts.
 - 2. Exposed Fasteners: Do not use exposed fasteners except for application of hardware. For application of hardware, use Phillips flat-head machine screws that match the finish of member or hardware being fastened.

- E. Concealed Flashing: 0.0179-inch (26 gage) minimum dead-soft stainless steel, or 0.026-inch-thick minimum extruded aluminum of alloy and type selected by manufacturer for compatibility with other components.
- F. Brackets and Reinforcements: Provide high-strength aluminum brackets and reinforcements; where use of aluminum is not feasible provide nonmagnetic stainless steel or hot-dip galvanized steel complying with ASTM A 123.
- H. Framing System Gaskets and Sealants: Manufacturer's standard, recommended by manufacturer for joint type.

2.3 ALUMINUM STOREFRONT HARDWARE SCHEDULE

- A. General: Install the items in the amounts indicated on the Drawings and schedules for a complete and operable facility.

2.4 COMPONENTS

- A. Storefront Framing System: Provide storefront and entrance framing systems fabricated from extruded aluminum members of size and profile indicated. Include subframes and other reinforcing members of the type indicated. Provide for storefront glazed from the exterior on all sides with projecting stops as scheduled. Shop-fabricate and preassemble frame components where possible. Provide storefront frame sections without exposed seams.

1. Mullion Configurations: Provide pockets at the inside glazing face to receive resilient elastomeric glazing. Mullions and horizontals shall be one piece.

2. Basis of Design: Subject to compliance with requirements of Contract Documents, provide product by manufacturer listed below

1. Manufacturer: **Kawneer** North America, an Alcoa company.

2. Product:

a. Framing: **Trifab VersaGlaze 451**.

b. Doors/Entrances: **500 Heavy Wall**.

2.5 FABRICATION

- A. General: Fabricate aluminum entrance and storefront components to designs, sizes and thicknesses indicated and to comply with indicated standards. Sizes and profile requirements are indicated on the drawings. Variable dimensions are indicated, with maximum and minimum dimensions required, to achieve design requirements and coordination with other work.
- B. Prefabrication: Complete fabrication, assembly, finishing, hardware application, and other work to the greatest extent possible before shipment to the Project site.
Disassemble components only as necessary for shipment and installation.
 - 1. Perform fabrication operations, including cutting, fitting, forming, drilling and grinding of metal work to prevent damage to exposed finish surfaces. Complete these operations for hardware prior to application of finishes.

2. Do not drill and tap for surface-mounted hardware items until time of installation at project site.

- C. Welding: Comply with AWS recommendations. Grind exposed welds smooth to remove weld spatter and welding oxides. Restore mechanical finish.
 - 1. Welding behind finished surfaces shall be performed in such a manner as to minimize distortion and discoloration on the finished surface.
- D. Reinforcing: Install reinforcing as required for hardware and as necessary for performance requirements, sag resistance and rigidity.
- E. Dissimilar Metals: Separate dissimilar metals with bituminous paint, or a suitable sealant, or a nonabsorptive plastic or elastomeric tape, or a gasket between the surfaces. Do not use coatings containing lead.
- F. Continuity: Maintain accurate relation of planes and angles with hairline fit of contacting members.
- G. Fasteners: Conceal fasteners wherever possible.
- H. Weather stripping: At interior locations without weather stripping, provide neoprene silencers on stops to prevent metal-to-metal contact.

2.6 FINISHES

- A. General: Comply with NAAMM's "Metal Finishes Manual for Architectural and Metal Products" for recommendations relative to applying and designating finishes.
- B. Appearance of Finished Work: Variations in appearance of abutting or adjacent pieces are acceptable if they are within one-half of the range of approved Samples. Noticeable variations in the same piece are not acceptable. Variations in appearance of other components are acceptable if they are within the range of approved Samples and are assembled or installed to minimize contrast.
- C. AA Designations: Finish designations prefixed by AA conform to the system established by the Aluminum Association for designating aluminum finishes.
- D. Clear Anodic Finish – Interior Surfaces: AAMA 611, AA-M12C22A41, Class I, 0.018 mm or thicker.

PART 3 - EXECUTION

3.1 EXAMINATION

- A. Examine substrates and supports, with the Installer present, for compliance with requirements indicated, installation tolerances, and other conditions that affect installation of aluminum entrances and storefronts. Correct unsatisfactory conditions before proceeding with the installation.
 - 1. Do not proceed with installation until unsatisfactory conditions are corrected.

3.2 INSTALLATION

- A. Comply with manufacturer's instructions and recommendations for installation.
- B. General: Set units plumb, level, and true to line, without warp or rack of framing members, doors, or panels. Install components in proper alignment and relation to established lines and grades indicated. Provide proper support and anchor securely in place.
- C. Construction Tolerances: Install aluminum entrance and storefront to comply with the following tolerances:
 - 1. Variation from Plane: Do not exceed 1/8 inch in 12 feet of length or 1/4 inch in any total length.
 - 2. Offset from Alignment: The maximum offset from true alignment between two identical members abutting end to end in line shall not exceed 1/16 inch.
 - 3. Diagonal Measurements: The maximum difference in diagonal measurements shall not exceed 1/8 inch.
 - 4. Offset at Corners: The maximum out-of-plane offset of framing at corners shall not exceed 1/32 inch.
- D. Separate aluminum and other corrodible metal surfaces from sources of corrosion or electrolytic action at points of contact with other materials.
 - 1. Zinc or cadmium plate steel anchors and other unexposed fasteners after fabrication.
 - 2. Paint dissimilar metals where drainage from them passes over aluminum.
 - 3. Paint aluminum surfaces in contact with mortar, concrete or other masonry with alkali resistant coating.
 - 4. Paint wood and similar absorptive material in contact with aluminum and exposed to the elements or otherwise subject to wetting, with two coats of aluminum house paint. Seal joints between the materials with sealant.
- E. Drill and tap frames and doors and apply surface-mounted hardware items. Comply with hardware manufacturer's instructions and template requirements. Use concealed fasteners wherever possible.
- F. Set sill members and other members in bed of sealant as indicated, or with joint fillers or gaskets as indicated to provide weathertight construction. Comply with requirements of Division 7 for sealants, fillers, and gaskets.
- G. Refer to "Glass and Glazing" Section of Division 8 for installation of glass and other panels indicated to be glazed into doors and framing, and not preglazed by manufacturer.

3.3 ADJUSTING

- A. Adjust operating hardware to function properly, for smooth operation without binding, and for weathertight closure.

3.4 CLEANING

- A. Clean the completed system, inside and out, promptly after installation, exercising care to avoid damage to coatings.

- B. Clean glass surfaces after installation, complying with requirements contained in the "Glass and Glazing" Section for cleaning and maintenance. Remove excess glazing and sealant compounds, dirt and other substances from aluminum surfaces.
- 3.5 PROTECTION
- A. Institute protective measures required throughout the remainder of the construction period to ensure that aluminum storefronts will be without damage or deterioration, other than normal weathering, at time of acceptance.

END OF SECTION

SECTION 087100 – DOOR HARDWARE

PART 1 - GENERAL

1.1 RELATED DOCUMENTS

- A. Drawings and general provisions of the Contract, including General and Supplementary Conditions and Division 1 Specification Sections, apply to this Section.

1.2 SUMMARY

- A. This Section includes commercial door hardware for the following:
 - 1. Swinging doors.
 - 2. Other doors to the extent indicated.
- B. Door hardware includes, but is not necessarily limited to, the following:
 - 1. Mechanical door hardware.
 - 2. Electromechanical door hardware.
- C. Related Sections:
 - 1. Division 08 Section "Hollow Metal Doors and Frames".
 - 2. Division 08 Section "Flush Wood Doors".
 - 3. Division 08 Section "Aluminum-Framed Entrances and Storefronts".
 - 4. Division 08 Section "Automatic Door Operators".
 - 5. Division 28 Section "Access Control Hardware Devices".
- D. Codes and References: Comply with the version year adopted by the Authority Having Jurisdiction.
 - 1. ANSI A117.1 - Accessible and Usable Buildings and Facilities.
 - 2. ICC/IBC - International Building Code.
 - 3. NFPA 70 - National Electrical Code.
 - 4. NFPA 80 - Fire Doors and Windows.
 - 5. NFPA 101 - Life Safety Code.
 - 6. NFPA 105 - Installation of Smoke Door Assemblies.
 - 7. UL/ULC and CSA C22.2 – Standards for Automatic Door Operators Used on Fire and Smoke Barrier Doors and Systems of Doors.
 - 8. State Building Codes, Local Amendments.
- E. Standards: All hardware specified herein shall comply with the following industry standards as applicable. Any undated reference to a standard shall be interpreted as referring to the latest edition of that standard:

1. ANSI/BHMA Certified Product Standards - A156 Series.
2. UL10C – Positive Pressure Fire Tests of Door Assemblies.
3. ANSI/UL 294 – Access Control System Units.
4. ULC-S319 - Electronic Access Control Systems.
5. ULC-60839-11-1, Alarm and Electronic Security Systems - Part 11-1: Electronic Access Control Systems - System and Components Requirements.
6. UL 305 – Panic Hardware.
7. ULC-S132, Emergency Exit and Emergency Fire Exit Hardware.
8. ULC-S533 – Egress Door Securing and Releasing Devices.
9. ANSI/UL 437- Key Locks.
10. ULC-S328, - Burglary Resistant Key Locks.

1.3 SUBMITTALS

- A. Product Data: Manufacturer's product data sheets including installation details, material descriptions, dimensions of individual components and profiles, operational descriptions and finishes.
- B. Door Hardware Schedule: Prepared by or under the supervision of supplier, detailing fabrication and assembly of door hardware, as well as procedures and diagrams. Coordinate the final Door Hardware Schedule with doors, frames, and related work to ensure proper size, thickness, hand, function, and finish of door hardware.
 1. Format: Comply with scheduling sequence and vertical format in DHI's "Sequence and Format for the Hardware Schedule."
 2. Organization: Organize the Door Hardware Schedule into door hardware sets indicating complete designations of every item required for each door or opening. Organize door hardware sets in same order as in the Door Hardware Sets at the end of Part 3. Submittals that do not follow the same format and order as the Door Hardware Sets will be rejected and subject to resubmission.
 3. Content: Include the following information:
 - a. Type, style, function, size, label, hand, and finish of each door hardware item.
 - b. Manufacturer of each item.
 - c. Fastenings and other pertinent information.
 - d. Location of door hardware set, cross-referenced to Drawings, both on floor plans and in door and frame schedule.
 - e. Explanation of abbreviations, symbols, and codes contained in schedule.
 - f. Mounting locations for door hardware.
 - g. Door and frame sizes and materials.
 - h. Warranty information for each product.
 4. Submittal Sequence: Submit the final Door Hardware Schedule at earliest possible date, particularly where approval of the Door Hardware Schedule must precede fabrication of other work that is critical in the Project construction schedule. Include Product Data, Samples, Shop Drawings of other work affected by door

hardware, and other information essential to the coordinated review of the Door Hardware Schedule.

- C. Shop Drawings: Details of electrified access control hardware indicating the following:
 - 1. Wiring Diagrams: Upon receipt of approved schedules, submit detailed system wiring diagrams for power, signaling, monitoring, communication, and control of the access control system electrified hardware. Differentiate between manufacturer-installed and field-installed wiring. Include the following:
 - a. Elevation diagram of each unique access controlled opening showing location and interconnection of major system components with respect to their placement in the respective door openings.
 - b. Complete (risers, point-to-point) access control system block wiring diagrams.
 - c. Wiring instructions for each electronic component scheduled herein.
 - 2. Electrical Coordination: Coordinate with related sections the voltages and wiring details required at electrically controlled and operated hardware openings.
- D. Keying Schedule: After a keying meeting with the owner has taken place prepare a separate keying schedule detailing final instructions. Submit the keying schedule in electronic format. Include keying system explanation, door numbers, key set symbols, hardware set numbers and special instructions. Owner must approve submitted keying schedule prior to the ordering of permanent cylinders/cores.
- E. Informational Submittals:
 - 1. Product Test Reports: Indicating compliance with cycle testing requirements, based on evaluation of comprehensive tests performed by manufacturer and witnessed by a qualified independent testing agency.
- F. Operating and Maintenance Manuals: Provide manufacturers operating and maintenance manuals for each item comprising the complete door hardware installation in quantity as required in Division 01, Closeout Procedures.

1.4 QUALITY ASSURANCE

- A. Manufacturers Qualifications: Engage qualified manufacturers with a minimum 5 years of documented experience in producing hardware and equipment similar to that indicated for this Project and that have a proven record of successful in-service performance.
- B. Certified Products: Where specified, products must maintain a current listing in the Builders Hardware Manufacturers Association (BHMA) Certified Products Directory (CPD).
- C. Installer Qualifications: A minimum 3 years documented experience installing both standard and electrified door hardware similar in material, design, and extent to that

indicated for this Project and whose work has resulted in construction with a record of successful in-service performance.

- D. Door Hardware Supplier Qualifications: Experienced commercial door hardware distributors with a minimum 5 years documented experience supplying both mechanical and electromechanical hardware installations comparable in material, design, and extent to that indicated for this Project. Supplier recognized as a factory direct distributor by the manufacturers of the primary materials with a warehousing facility in Project's vicinity. Supplier to have on staff a certified Architectural Hardware Consultant (AHC) available during the course of the Work to consult with Contractor, Architect, and Owner concerning both standard and electromechanical door hardware and keying.
- E. Integrated Wiegand, Wireless, and IP-Enabled Access Control Products Supplier Qualifications: Integrated access control products and accessories are required to be supplied and installed through current members of the ASSA ABLOY "Authorized Channel Partner" (ACP) and "Certified Integrator" (CI) programs. Suppliers are to be factory trained, certified prior to project bid, and a direct purchaser of the specified product. Installers are to be factory trained, certified prior to project bid, and are responsible for commissioning, servicing, and warranting the installed equipment specified for the project.
- F. Source Limitations: Obtain each type and variety of door hardware specified in this section from a single source unless otherwise indicated.
1. Electrified modifications or enhancements made to a source manufacturer's product line by a secondary or third party source will not be accepted.
 2. Provide electromechanical door hardware from the same manufacturer as mechanical door hardware, unless otherwise indicated.
- G. Each unit to bear third party permanent label demonstrating compliance with the referenced standards.
- H. Keying Conference: Conduct conference to comply with requirements in Division 01 Section "Project Meetings." Keying conference to incorporate the following criteria into the final keying schedule document:
1. Function of building, purpose of each area and degree of security required.
 2. Plans for existing and future key system expansion.
 3. Requirements for key control storage and software.
 4. Installation of permanent keys, cylinder cores and software.
 5. Address and requirements for delivery of keys.
- I. Pre-Submittal Conference: Conduct coordination conference in compliance with requirements in Division 01 Section "Project Meetings" with attendance by representatives of Supplier(s), Installer(s), and Contractor(s) to review proper methods and the procedures for receiving, handling, and installing door hardware.
1. Prior to installation of door hardware, conduct a project specific training meeting to instruct the installing contractors' personnel on the proper installation and

adjustment of their respective products. Product training to be attended by installers of door hardware (including electromechanical hardware) for aluminum, hollow metal and wood doors. Training will include the use of installation manuals, hardware schedules, templates and physical product samples as required.

2. Inspect and discuss electrical roughing-in, power supply connections, and other preparatory work performed by other trades.
3. Review sequence of operation narratives for each unique access controlled opening.
4. Review and finalize construction schedule and verify availability of materials.
5. Review the required inspecting, testing, commissioning, and demonstration procedures

- J. At completion of installation, provide written documentation that components were applied to manufacturer's instructions and recommendations and according to approved schedule.

1.5 DELIVERY, STORAGE, AND HANDLING

- A. Inventory door hardware on receipt and provide secure lock-up and shelving for door hardware delivered to Project site. Do not store electronic access control hardware, software or accessories at Project site without prior authorization.
- B. Tag each item or package separately with identification related to the final Door Hardware Schedule, and include basic installation instructions with each item or package.
- C. Deliver, as applicable, permanent keys, cylinders, cores, access control credentials, software and related accessories directly to Owner via registered mail or overnight package service. Instructions for delivery to the Owner shall be established at the "Keying Conference".

1.6 COORDINATION

- A. Templates: Obtain and distribute to the parties involved templates for doors, frames, and other work specified to be factory prepared for installing standard and electrified hardware. Check Shop Drawings of other work to confirm that adequate provisions are made for locating and installing hardware to comply with indicated requirements.
- B. Door Hardware and Electrical Connections: Coordinate the layout and installation of scheduled electrified door hardware and related access control equipment with required connections to source power junction boxes, low voltage power supplies, detection and monitoring hardware, and fire and detection alarm systems.
- C. Door and Frame Preparation: Doors and corresponding frames are to be prepared, reinforced and pre-wired (if applicable) to receive the installation of the specified electrified, monitoring, signaling and access control system hardware without additional in-field modifications.

1.7 WARRANTY

- A. General Warranty: Reference Division 01, General Requirements. Special warranties specified in this Article shall not deprive Owner of other rights Owner may have under other provisions of the Contract Documents and shall be in addition to, and run concurrent with, other warranties made by Contractor under requirements of the Contract Documents.
- B. Warranty Period: Written warranty, executed by manufacturer(s), agreeing to repair or replace components of standard and electrified door hardware that fails in materials or workmanship within specified warranty period after final acceptance by the Owner. Failures include, but are not limited to, the following:
 - 1. Structural failures including excessive deflection, cracking, or breakage.
 - 2. Faulty operation of the hardware.
 - 3. Deterioration of metals, metal finishes, and other materials beyond normal weathering.
 - 4. Electrical component defects and failures within the systems operation.
- C. Standard Warranty Period: One year from date of Substantial Completion, unless otherwise indicated.
- D. Special Warranty Periods:
 - 1. Ten years for mortise locks and latches.
 - 2. Five years for exit hardware.
 - 3. Twenty five years for manual overhead door closer bodies.
 - 4. Five years for motorized electric latch retraction exit devices.
 - 5. Two years for electromechanical door hardware.

1.8 MAINTENANCE SERVICE

- A. Maintenance Tools and Instructions: Furnish a complete set of specialized tools and maintenance instructions as needed for Owner's continued adjustment, maintenance, and removal and replacement of door hardware.

PART 2 - PRODUCTS

2.1 SCHEDULED DOOR HARDWARE

- A. General: Provide door hardware for each door to comply with requirements in Door Hardware Sets and each referenced section that products are to be supplied under.
- B. Designations: Requirements for quantity, item, size, finish or color, grade, function, and other distinctive qualities of each type of door hardware are indicated in the Door Hardware Sets at the end of Part 3. Products are identified by using door hardware designations, as follows:

1. Named Manufacturer's Products: Product designation and manufacturer are listed for each door hardware type required for the purpose of establishing requirements. Manufacturers' names are abbreviated in the Door Hardware Schedule.
- C. Substitutions: Requests for substitution and product approval for inclusive mechanical and electromechanical door hardware in compliance with the specifications must be submitted in writing and in accordance with the procedures and time frames outlined in Division 01, Substitution Procedures. Approval of requests is at the discretion of the architect, owner, and their designated consultants.

2.2 HANGING DEVICES

- A. Hinges: ANSI/BHMA A156.1 certified butt hinges with number of hinge knuckles and other options as specified in the Door Hardware Sets.
1. Quantity: Provide the following hinge quantity:
 - a. Two Hinges: For doors with heights up to 60 inches.
 - b. Three Hinges: For doors with heights 61 to 90 inches.
 - c. Four Hinges: For doors with heights 91 to 120 inches.
 - d. For doors with heights more than 120 inches, provide 4 hinges, plus 1 hinge for every 30 inches of door height greater than 120 inches.
 2. Hinge Size: Provide the following, unless otherwise indicated, with hinge widths sized for door thickness and clearances required:
 - a. Widths up to 3'0": 4-1/2" standard or heavy weight as specified.
 - b. Sizes from 3'1" to 4'0": 5" standard or heavy weight as specified.
 3. Hinge Weight and Base Material: Unless otherwise indicated, provide the following:
 - a. Exterior Doors: Heavy weight, non-ferrous, ball bearing or oil impregnated bearing hinges unless Hardware Sets indicate standard weight.
 - b. Interior Doors: Standard weight, steel, ball bearing or oil impregnated bearing hinges unless Hardware Sets indicate heavy weight.
 4. Hinge Options: Comply with the following:
 - a. Non-removable Pins: Provide set screw in hinge barrel that, when tightened into a groove in hinge pin, prevents removal of pin while door is closed; for the all out-swinging lockable doors.
 5. Manufacturers:
 - a. Hager Companies (HA).
 - b. McKinney Products; ASSA ABLOY Architectural Door Accessories (MK).
 - c. Stanley Hardware (ST).

- B. Continuous Geared Hinges: ANSI/BHMA A156.26 Grade 1-600 certified continuous geared hinge, with minimum 0.120-inch thick extruded 6060 T6 aluminum alloy hinge leaves and a minimum overall width of 4 inches. Hinges are non-handed, reversible and fabricated to template screw locations. Factory trim hinges to suit door height and prepare for electrical cut-outs.
1. Manufacturers:
 - a. Bommer Industries (BO).
 - b. Hager Companies (HA).
 - c. Pemko Products; ASSA ABLOY Architectural Door Accessories (PE).

2.3 POWER TRANSFER DEVICES

- A. Concealed Quick Connect Electric Power Transfers: Provide concealed wiring pathway housing mortised into the door and frame for low voltage electrified door hardware. Furnish with Molex™ standardized plug connectors and sufficient number of concealed wires (up to 12) to accommodate the electrified functions specified in the Door Hardware Sets. Connectors plug directly to through-door wiring harnesses for connection to electric locking devices and power supplies. Wire nut connections are not acceptable.
1. Manufacturers:
 - a. Pemko Products; ASSA ABLOY Architectural Door Accessories (PE) – EL-CEPT Series.
 - b. Securitron (SU) - EL-CEPT Series.
 - c. Von Duprin (VD) - EPT-10 Series.

 - B. Electric Door Wire Harnesses: Provide electric/data transfer wiring harnesses with standardized plug connectors to accommodate up to twelve (12) wires. Connectors plug directly to through-door wiring harnesses for connection to electric locking devices and power supplies. Provide sufficient number and type of concealed wires to accommodate electric function of specified hardware. Provide a connector for through-door electronic locking devices and from hinge to junction box above the opening. Wire nut connections are not acceptable. Determine the length required for each electrified hardware component for the door type, size and construction, minimum of two per electrified opening.
 1. Provide one each of the following tools as part of the base bid contract:
 - a. McKinney Products; ASSA ABLOY Architectural Door Accessories (MK) - Electrical Connecting Kit: QC-R001.
 - b. McKinney Products; ASSA ABLOY Architectural Door Accessories (MK) - Connector Hand Tool: QC-R003.

 2. Manufacturers:
 - a. Hager Companies (HA) - Quick Connect.

- b. McKinney Products; ASSA ABLOY Architectural Door Accessories (MK) – QC-C Series.
- c. Stanley Hardware (ST) – WH Series.

2.4 DOOR OPERATING TRIM

- A. Flush Bolts and Surface Bolts: ANSI/BHMA A156.3 and A156.16, Grade 1, certified.
 - 1. Flush bolts to be furnished with top rod of sufficient length to allow bolt retraction device location approximately six feet from the floor.
 - 2. Furnish dust proof strikes for bottom bolts.
 - 3. Surface bolts to be minimum 8" in length and U.L. listed for labeled fire doors and U.L. listed for windstorm components where applicable.
 - 4. Provide related accessories (mounting brackets, strikes, coordinators, etc.) as required for appropriate installation and operation.
 - 5. Manufacturers:
 - a. Door Controls International (DC).
 - b. Rockwood Products; ASSA ABLOY Architectural Door Accessories (RO).
 - c. Trimco (TC).
- B. Door Push Plates and Pulls: ANSI/BHMA A156.6 certified door pushes and pulls of type and design specified in the Hardware Sets. Coordinate and provide proper width and height as required where conflicting hardware dictates.
 - 1. Push/Pull Plates: Minimum .050 inch thick, size as indicated in hardware sets, with beveled edges, secured with exposed screws unless otherwise indicated.
 - 2. Door Pull and Push Bar Design: Size, shape, and material as indicated in the hardware sets. Minimum clearance of 2 1/2-inches from face of door unless otherwise indicated.
 - 3. Offset Pull Design: Size, shape, and material as indicated in the hardware sets. Minimum clearance of 2 1/2-inches from face of door and offset of 90 degrees unless otherwise indicated.
 - 4. Fasteners: Provide manufacturer's designated fastener type as indicated in Hardware Sets.
 - 5. Manufacturers:
 - a. Hiawatha, Inc. (HI).
 - b. Rockwood Products; ASSA ABLOY Architectural Door Accessories (RO).
 - c. Trimco (TC).

2.5 CYLINDERS AND KEYING

- A. General: Cylinder manufacturer to have minimum (10) years experience designing secured master key systems and have on record a published security keying system policy.

- B. Source Limitations: Obtain each type of keyed cylinder and keys from the same source manufacturer as locksets and exit devices, unless otherwise indicated.
 - 1. Manufacturers:
 - a. Schlage (SC).
- C. Cylinders: Original manufacturer cylinders complying with the following:
 - 1. Mortise Type: Threaded cylinders with rings and cams to suit hardware application.
 - 2. Rim Type: Cylinders with back plate, flat-type vertical or horizontal tailpiece, and raised trim ring.
 - 3. Bored-Lock Type: Cylinders with tailpieces to suit locks.
 - 4. Mortise and rim cylinder collars to be solid and recessed to allow the cylinder face to be flush and be free spinning with matching finishes.
 - 5. Keyway: Manufacturer's Standard.
- D. Removable Cores: Provide removable cores as specified, core insert, removable by use of a special key, and for use with only the core manufacturer's cylinder and door hardware.
- E. Keying System: Each type of lock and cylinders to be factory keyed.
 - 1. Supplier shall conduct a "Keying Conference" to define and document keying system instructions and requirements.
 - 2. Furnish factory cut, nickel-silver large bow permanently inscribed with a visual key control number as directed by Owner.
 - 3. New System: Key locks to a new key system as directed by the Owner.
- F. Key Quantity: Provide the following minimum number of keys:
 - 1. Change Keys per Cylinder: Two (2)
 - 2. Master Keys (per Master Key Level/Group): Five (5).
 - 3. Construction Keys (where required): Ten (10).
- G. Construction Keying: Provide construction master keyed cylinders.
- H. Key Registration List (Bitting List):
 - 1. Provide keying transcript list to Owner's representative in the proper format for importing into key control software.
 - 2. Provide transcript list in writing or electronic file as directed by the Owner.

2.6 MECHANICAL LOCKS AND LATCHING DEVICES

- A. Mortise Locksets, Grade 1 (Heavy Duty): ANSI/BHMA A156.13, Series 1000, Operational Grade 1 Certified Products Directory (CPD) listed. Locksets are to be manufactured with a corrosion resistant steel case and be field-reversible for handing without disassembly of the lock body.

1. Where specified, provide status indicators with highly reflective color and wording for "locked/unlocked" or "vacant/occupied" with custom wording options if required. Indicator to be located above the cylinder with the inside thumb-turn not blocking the visibility of the indicator status. Indicator window size to be a minimum of 2.1" x 0.6" with a curved design allowing a 180 degree viewing angle with protective covering to prevent tampering.
2. Manufacturers:
 - a. Sargent Manufacturing (SA) – 8200 Series.
 - b. No Substitution.

2.7 AUXILIARY LOCKS

- A. Push-Pull Latches, Paddle Type, Mortise: ANSI/BHMA A156.13, Series 1000, Operational and Security Grade 1 mortise type push-pull locks and latches with ligature-resistant paddle trim capable of being mounted in vertical (up or down) and horizontal (sideways) positions. Locksets to be manufactured with a corrosion resistant, formed steel case and be non-handed, field-reversible for re-handing without disassembly of the lock body. Paddles and covers are manufactured from cast stainless steel or brass material. Provide optional lead-lining (lock body) and Torx® fasteners as specified in Hardware Sets.
 1. Manufacturers:
 - a. Sargent Manufacturing (SA) - 8200 ALP Series.

2.8 LOCK AND LATCH STRIKES

- A. Strikes: Provide manufacturer's standard strike with strike box for each latch or lock bolt, with curved lip extended to protect frame, finished to match door hardware set, unless otherwise indicated, and as follows:
 1. Flat-Lip Strikes: For locks with three-piece antifriction latchbolts, as recommended by manufacturer.
 2. Extra-Long-Lip Strikes: For locks used on frames with applied wood casing trim.
 3. Aluminum-Frame Strike Box: Provide manufacturer's special strike box fabricated for aluminum framing.
 4. Double-lipped strikes: For locks at double acting doors. Furnish with retractable stop for rescue hardware applications.
- B. Standards: Comply with the following:
 1. Strikes for Mortise Locks and Latches: BHMA A156.13.
 2. Strikes for Bored Locks and Latches: BHMA A156.2.
 3. Strikes for Auxiliary Deadlocks: BHMA A156.36.
 4. Dustproof Strikes: BHMA A156.16.

2.9 ELECTROMAGNETIC LOCKING DEVICES

- A. Surface Electromagnetic Locks (Extra Heavy Duty): Electromagnetic locks to be surface mounted type tested to ANSI A156.23, Grade 1 with minimum holding force strength of 1,800 pounds. Locks to be capable of either 12 or 24 voltage and be UL listed for use on fire rated door assemblies. Electronics are to be fully sealed against tampering and allow exterior weatherproof applications. As indicated in Hardware Sets, provide specified mounting brackets and housings. Power supply to be by the same manufacturer as the lock with combined products having a lifetime replacement warranty.

1. Manufacturers:

- a. Schlage (SC) – M490 Series.
- b. Securitron (SU) – M82 Series.

2.10 ELECTRIC STRIKES

- A. Standard Electric Strikes: Electric strikes tested to ANSI/BHMA A156.31, Grade 1, for use on non-rated or fire rated openings. Strikes shall be of stainless steel construction tested to a minimum of 1500 pounds of static strength and 70 foot-pounds of dynamic strength with a minimum endurance of 1 million operating cycles. Provide strikes with 12 or 24 VDC capability, fail-secure unless otherwise specified. Where specified provide latchbolt and latchbolt strike monitoring indicating both the position of the latchbolt and locked condition of the strike.

1. Manufacturers:

- a. HES (HS) - 1006 Series.
- b. Von Duprin (VD) - 6200/6400 Series.

- B. Surface Mounted Rim Electric Strikes: Surface mounted rim exit device electric strikes tested to ANSI/BHMA A156.31, Grade 1, and UL Listed for both Burglary Resistance and for use on fire rated door assemblies. Construction includes internally mounted solenoid with two heavy-duty, stainless steel locking mechanisms operating independently to provide tamper resistance. Strikes tested for a minimum of 500,000 operating cycles. Provide strikes with 12 or 24 VDC capability supplied standard as fail-secure unless otherwise specified. Option available for latchbolt and latchbolt strike monitoring indicating both the position of the latchbolt and locked condition of the strike. Strike requires no cutting to the jamb prior to installation.

1. Manufacturers:

- a. HES (HS) - 9400/9500/9600/9700/9800 Series.
- b. Von Duprin (VD) - VD3146/6200/6300 Series.

- C. Provide electric strikes with in-line power controller and surge suppressor by the same manufacturer as the strike with the combined products having a five year warranty.

2.11 CONVENTIONAL EXIT DEVICES

- A. General Requirements: All exit devices specified herein shall meet or exceed the following criteria:
1. At doors not requiring a fire rating, provide devices complying with NFPA 101 and listed and labeled for "Panic Hardware" according to UL305. Provide proper fasteners as required by manufacturer including sex nuts and bolts at openings specified in the Hardware Sets.
 2. Where exit devices are required on fire rated doors, provide devices complying with NFPA 80 and with UL labeling indicating "Fire Exit Hardware". Provide devices with the proper fasteners for installation as tested and listed by UL. Consult manufacturer's catalog and template book for specific requirements.
 3. Except on fire rated doors, provide exit devices with hex key dogging device to hold the pushbar and latch in a retracted position. Provide optional keyed cylinder dogging on devices where specified in Hardware Sets.
 4. Devices must fit flat against the door face with no gap that permits unauthorized dogging of the push bar. The addition of filler strips is required in any case where the door light extends behind the device as in a full glass configuration.
 5. Energy Efficient Design: Provide lock bodies which have a holding current draw of 15mA maximum, and can operate on either 12 or 24 volts. Locks are to be field configurable for fail safe or fail secure operation.
 6. Electromechanical Options: Subject to same compliance standards and requirements as mechanical exit devices, electrified devices to be of type and design as specified in hardware sets. Include any specific controllers when conventional power supplies are not sufficient to provide the proper inrush current.
 7. Motorized Electric Latch Retraction: Devices with an electric latch retraction feature must use motors which have a maximum current draw of 600mA. Solenoid driven latch retraction is not acceptable.
 8. Lever Operating Trim: Where exit devices require lever trim, furnish manufacturer's heavy duty escutcheon trim with threaded studs for thru-bolts.
 - a. Lock Trim Design: As indicated in Hardware Sets, provide finishes and designs to match that of the specified locksets.
 - b. Where function of exit device requires a cylinder, provide a cylinder (Rim or Mortise) as specified in Hardware Sets.
 9. Vertical Rod Exit Devices: Where surface or concealed vertical rod exit devices are used at interior openings, provide as less bottom rod (LBR) unless otherwise indicated. Provide dust proof strikes where thermal pins are required to project into the floor.

10. Narrow Stile Applications: At doors constructed with narrow stiles, or as specified in Hardware Sets, provide devices designed for maximum 2" wide stiles.
 11. Dummy Push Bar: Nonfunctioning push bar matching functional push bar.
 12. Rail Sizing: Provide exit device rails factory sized for proper door width application.
 13. Through Bolt Installation: For exit devices and trim as indicated in Door Hardware Sets.
- B. Conventional Push Rail Exit Devices (Heavy Duty): ANSI/BHMA A156.3, Grade 1 Certified Products Directory (CPD) listed panic and fire exit hardware devices furnished in the functions specified in the Hardware Sets. Exit device latch to be stainless steel, pullman type, with deadlock feature.
1. Manufacturers:
 - a. Corbin Russwin Hardware (RU) - ED4000 / ED5000 Series.
 - b. Sargent Manufacturing (SA) - 80 Series.
 - c. Von Duprin (VD) - 35A/98 XP Series.

2.12 DOOR CLOSERS

- A. All door closers specified herein shall meet or exceed the following criteria:
1. General: Door closers to be from one manufacturer, matching in design and style, with the same type door preparations and templates regardless of application or spring size. Closers to be non-handed with full sized covers.
 2. Standards: Closers to comply with UL-10C for Positive Pressure Fire Test and be U.L. listed for use of fire rated doors.
 3. Size of Units: Comply with manufacturer's written recommendations for sizing of door closers depending on size of door, exposure to weather, and anticipated frequency of use. Where closers are indicated for doors required to be accessible to the Americans with Disabilities Act, provide units complying with ANSI ICC/A117.1.
 4. Closer Arms: Provide heavy duty, forged steel closer arms unless otherwise indicated in Hardware Sets.
 5. Closers shall not be installed on exterior or corridor side of doors; where possible install closers on door for optimum aesthetics.
 6. Closer Accessories: Provide door closer accessories including custom templates, special mounting brackets, spacers and drop plates as required for proper installation. Provide through-bolt and security type fasteners as specified in the hardware sets.

- B. Door Closers, Surface Mounted (Heavy Duty): ANSI/BHMA A156.4, Grade 1 Certified Products Directory (CPD) listed surface mounted, heavy duty door closers with complete spring power adjustment, sizes 1 thru 6; and fully operational adjustable according to door size, frequency of use, and opening force. Closers to be rack and pinion type, one piece cast iron or aluminum alloy body construction, with adjustable backcheck and separate non-critical valves for closing sweep and latch speed control. Provide non-handed units standard.
1. Manufacturers:
 - a. LCN Closers (LC) – 4040SE Series.
 - b. Norton Door Controls (NO) – 7500 Series.
 - c. Sargent Manufacturing (SA) – 351 Series.

2.13 SURFACE MOUNTED CLOSER HOLDERS

- A. Multi-Point Closer Holders with Motion Sensor: ANSI A156.15, Grade 1 certified multi-point, closer holder devices designed to keep doors in a held-open position if presence is detected within the opening. Push side or pull side mounting applications having a maximum opening of 180° (hold open to 175°) and dual voltage input (24V /120V). Voltage to be 24VDC unless otherwise specified. Units are fail safe, closing the door in the event of fire alarm system or electrical power interruption.
1. Safe Zone Detection: Closer holders units to have an integral motion sensor device monitoring a "zone of safety" at the door opening. Safe zone detection prevents the door from closing in event of movement within the adjustable sensing field. Movement is detectable in both directions with selectable closer hold open time and sensor sensitivity. Provide optional handheld device for programming safe zone sensor settings.
 2. Manufacturers:
 - a. Norton Door Controls (NO) - 7100SZ Series.

2.14 ARCHITECTURAL TRIM

- A. Door Protective Trim
1. General: Door protective trim units to be of type and design as specified below or in the Hardware Sets.
 2. Size: Fabricate protection plates (kick, armor, or mop) not more than 2" less than door width (LDW) on stop side of single doors and 1" LDW on stop side of pairs of doors, and not more than 1" less than door width on pull side. Coordinate and provide proper width and height as required where conflicting hardware dictates. Height to be as specified in the Hardware Sets.
 3. Where plates are applied to fire rated doors with the top of the plate more than 16" above the bottom of the door, provide plates complying with NFPA 80.

Consult manufacturer's catalog and template book for specific requirements for size and applications.

4. Protection Plates: ANSI/BHMA A156.6 certified protection plates (kick, armor, or mop), fabricated from the following:
 - a. Stainless Steel: 300 grade, 050-inch thick.
5. Options and fasteners: Provide manufacturer's designated fastener type as specified in the Hardware Sets. Provide countersunk screw holes.
6. Manufacturers:
 - a. Hiawatha, Inc. (HI).
 - b. Rockwood Products; ASSA ABLOY Architectural Door Accessories (RO).
 - c. Trimco (TC).

2.15 DOOR STOPS AND HOLDERS

- A. General: Door stops and holders to be of type and design as specified below or in the Hardware Sets.
- B. Door Stops and Bumpers: ANSI/BHMA A156.16, Grade 1 certified door stops and wall bumpers. Provide wall bumpers, either convex or concave types with anchorage as indicated, unless floor or other types of door stops are specified in Hardware Sets. Do not mount floor stops where they will impede traffic. Where floor or wall bumpers are not appropriate, provide overhead type stops and holders.
 1. Manufacturers:
 - a. Hiawatha, Inc. (HI).
 - b. Rockwood Products; ASSA ABLOY Architectural Door Accessories (RO).
 - c. Trimco (TC).
- C. Overhead Door Stops and Holders: ANSI/BHMA A156.8, Grade 1 Certified Products Directory (CPD) listed overhead stops and holders to be surface or concealed types as indicated in Hardware Sets. Track, slide, arm and jamb bracket to be constructed of extruded bronze and shock absorber spring of heavy tempered steel. Provide non-handed design with mounting brackets as required for proper operation and function.
 1. Manufacturers:
 - a. Rixson Door Controls (RF).
 - b. Sargent Manufacturing (SA).

2.16 ARCHITECTURAL SEALS

- A. General: Thresholds, weatherstripping, and gasket seals to be of type and design as specified below or in the Hardware Sets. Provide continuous weatherstrip gasketing on exterior doors and provide smoke, light, or sound gasketing on interior doors where indicated. At exterior applications provide non-corrosive fasteners and elsewhere where indicated.
- B. Smoke Labeled Gasketing: Assemblies complying with NFPA 105 that are listed and labeled by a testing and inspecting agency acceptable to authorities having jurisdiction, for smoke control ratings indicated, based on testing according to UL 1784.
 - 1. Provide smoke labeled perimeter gasketing at all smoke labeled openings.
- C. Fire Labeled Gasketing: Assemblies complying with NFPA 80 that are listed and labeled by a testing and inspecting agency acceptable to authorities having jurisdiction, for fire ratings indicated, based on testing according to UL-10C.
 - 1. Provide intumescent seals as indicated to meet UL10C Standard for Positive Pressure Fire Tests of Door Assemblies, and NPFA 252, Standard Methods of Fire Tests of Door Assemblies.
- D. Sound-Rated Gasketing: Assemblies that are listed and labeled by a testing and inspecting agency, for sound ratings indicated.
- E. Replaceable Seal Strips: Provide only those units where resilient or flexible seal strips are easily replaceable and readily available from stocks maintained by manufacturer.
- F. Manufacturers:
 - 1. National Guard Products (NG).
 - 2. Pemko Products; ASSA ABLOY Architectural Door Accessories (PE).
 - 3. Reese Enterprises, Inc. (RE).

2.17 ELECTRONIC ACCESSORIES

- A. Switching Power Supplies: Provide power supplies with either single or dual voltage configurations at 12 or 24VDC. Power supplies shall have battery backup function with an integrated battery charging circuit and shall provide capability for power distribution, direct lock control and Fire Alarm Interface (FAI) through add on modules. Power supplies shall be expandable up to 16 individually protected outputs. Output modules shall provide individually protected, continuous outputs and/or individually protected, relay controlled outputs.
 - 1. Manufacturers:
 - a. Securitron (SU) - AQD Series.

2.18 FABRICATION

- A. Fasteners: Provide door hardware manufactured to comply with published templates generally prepared for machine, wood, and sheet metal screws. Provide screws according to manufacturers recognized installation standards for application intended.

2.19 FINISHES

- A. Standard: Designations used in the Hardware Sets and elsewhere indicate hardware finishes complying with ANSI/BHMA A156.18, including coordination with traditional U.S. finishes indicated by certain manufacturers for their products.
- B. Provide quality of finish, including thickness of plating or coating (if any), composition, hardness, and other qualities complying with manufacturer's standards, but in no case less than specified by referenced standards for the applicable units of hardware
- C. Protect mechanical finishes on exposed surfaces from damage by applying a strippable, temporary protective covering before shipping.

PART 3 - EXECUTION

3.1 EXAMINATION

- A. Examine scheduled openings, with Installer present, for compliance with requirements for installation tolerances, labeled fire door assembly construction, wall and floor construction, and other conditions affecting performance.
- B. Notify architect of any discrepancies or conflicts between the door schedule, door types, drawings and scheduled hardware. Proceed only after such discrepancies or conflicts have been resolved in writing.

3.2 PREPARATION

- A. Hollow Metal Doors and Frames: Comply with ANSI/DHI A115 series.
- B. Wood Doors: Comply with ANSI/DHI A115-W series.

3.3 INSTALLATION

- A. Install each item of mechanical and electromechanical hardware and access control equipment to comply with manufacturer's written instructions and according to specifications.
 - 1. Installers are to be trained and certified by the manufacturer on the proper installation and adjustment of fire, life safety, and security products including: hanging devices; locking devices; closing devices; and seals.

- B. Mounting Heights: Mount door hardware units at heights indicated in following applicable publications, unless specifically indicated or required to comply with governing regulations:
1. Standard Steel Doors and Frames: DHI's "Recommended Locations for Architectural Hardware for Standard Steel Doors and Frames."
 2. Wood Doors: DHI WDHS.3, "Recommended Locations for Architectural Hardware for Wood Flush Doors."
 3. Where indicated to comply with accessibility requirements, comply with ANSI A117.1 "Accessibility Guidelines for Buildings and Facilities."
 4. Provide blocking in drywall partitions where wall stops or other wall mounted hardware is located.
- C. Retrofitting: Install door hardware to comply with manufacturer's published templates and written instructions. Where cutting and fitting are required to install door hardware onto or into surfaces that are later to be painted or finished in another way, coordinate removal, storage, and reinstallation of surface protective trim units with finishing work specified in Division 9 Sections. Do not install surface-mounted items until finishes have been completed on substrates involved.
- D. Thresholds: Set thresholds for exterior and acoustical doors in full bed of sealant complying with requirements specified in Division 7 Section "Joint Sealants."
- E. Storage: Provide a secure lock up for hardware delivered to the project but not yet installed. Control the handling and installation of hardware items so that the completion of the work will not be delayed by hardware losses before and after installation.

3.4 FIELD QUALITY CONTROL

- A. Field Inspection (Punch Report): Reference Division 01 Sections "Closeout Procedures" and "Cash Allowances". Produce project punch report for each installed door opening indicating compliance with approved submittals and verification hardware is properly installed, operating and adjusted. Include list of items to be completed and corrected, indicating the reasons or deficiencies causing the Work to be incomplete or rejected.
1. Organization of List: Include separate Door Opening and Deficiencies and Corrective Action Lists organized by Mark, Opening Remarks and Comments, and related Opening Images and Video Recordings.
 2. Submit documentation of incomplete items in the following formats:
 - a. PDF electronic file.
 - b. Electronic formatted file integrated with the Openings Studio™ door opening management software platform.

3.5 ADJUSTING

- A. Initial Adjustment: Adjust and check each operating item of door hardware and each door to ensure proper operation or function of every unit. Replace units that cannot be adjusted to operate as intended. Adjust door control devices to compensate for final operation of heating and ventilating equipment and to comply with referenced accessibility requirements.

3.6 CLEANING AND PROTECTION

- A. Protect all hardware stored on construction site in a covered and dry place. Protect exposed hardware installed on doors during the construction phase. Install any and all hardware at the latest possible time frame.
- B. Clean adjacent surfaces soiled by door hardware installation.
- C. Clean operating items as necessary to restore proper finish. Provide final protection and maintain conditions that ensure door hardware is without damage or deterioration at time of owner occupancy.

3.7 DEMONSTRATION

- A. Instruct Owner's maintenance personnel to adjust, operate, and maintain mechanical and electromechanical door hardware.

3.8 DOOR HARDWARE SETS

- A. The hardware sets represent the design intent and direction of the owner and architect. They are a guideline only and should not be considered a detailed hardware schedule. Discrepancies, conflicting hardware and missing items should be brought to the attention of the architect with corrections made prior to the bidding process. Omitted items not included in a hardware set should be scheduled with the appropriate additional hardware required for proper application and functionality.
 1. Quantities listed are for each pair of doors, or for each single door.
 2. The supplier is responsible for handing and sizing all products.
 3. Where multiple options for a piece of hardware are given in a single line item, the supplier shall provide the appropriate application for the opening.
 4. At existing openings with new hardware the supplier shall field inspect existing conditions prior to the submittal stage to verify the specified hardware will work as required. Provide alternate solutions and proposals as needed.
- B. Manufacturer's Abbreviations:

1. MK - McKinney
2. PE - Pemko
3. RO - Rockwood
4. SU - Securitron
5. SA - SARGENT
6. SC - Schlage
7. HS - HES
8. RF - Rixson
9. NO - Norton

Hardware Sets

Set: 1.0

Doors: [A450](#)

6 Hinge, Half Surface, Hvy Wt	T4A3782	US26D	MK
1 Magnetic Lock	M82BD		SU ⚡
2 Fire Rated SVR Exit (EO-MELR)	12 56 NB8710 EO	US32D	SA ⚡
1 Surface Door Operator (Dbl Egress)		Stanley Magic-Force	
Series	628	ST	⚡
2 Kick Plate	K1050 10"	US32D	RO
2 SS Door Frame Cover	See section 102600	630	OT
2 Wall Stop	415	US26D	RO
1 Gasketing	S44BL		PE
1 Meeting Stile Seal	S771C		PE
2 Electric Power Transfer	EL-CEPT		SU ⚡
2 Frame Harness	QC-C1500P (as required)		MK ⚡
2 Door Harness	QC-CXXXP (as required)		MK ⚡
1 Wave-to-Open Wall Switch	700		NO ⚡
1 Power Supply	AQD (size as req.) x PDB (as req.)		SU ⚡
1 Card Reader	Provided by access control		OT

Notes:

Controlled Egress Door electronic locking system.
 Doors normally closed and one leaf locked electromagnetically.
 Egress by valid credential releasing the electromagnetic lock on leaf one. Free egress at all times on leaf two.
 Coordination required for card access and automatic door operator use.

Set: 2.0

Doors: [A433](#)

3 Hinge, Full Mortise, Hvy Wt	T4A3786 (NRP)	US26D	MK
1 Access Control Exit (BY DIV 28)	12 M1-8875-24V-IPS ETL LC	US32D	SA ⚡
1 Cylinder	Match existing	626	SC
1 Surface Closer	PR7500 TBGN	689	NO
1 Kick Plate	K1050 10"	US32D	RO
1 Wall Stop	403	US26D	RO

1 Gasketing	S44BL		PE
1 Electric Power Transfer	EL-CEPT		SU ⚡
1 Frame Harness	QC-C1500P (as required)		MK ⚡
1 Door Harness	QC-CXXXP (as required)		MK ⚡
1 Power Supply	Provided by access control		

Notes:

Door normally closed and locked.

Entry by valid credential presented to the integrated card reader unlocking the lever on the key side of the door; mechanical key override.

Free egress at all times.

Upon the loss of power or signal from the fire alarm the doors are unlocked and closed.

Fail Safe.

Set: 3.0

Doors: A404

1 Continuous Hinge	CFMXXSLF-HD1		PE
1 Rim Exit Device (CLASS)	LC 8813 ETL	US32D	SA
1 Cylinder	Match existing	626	SC
1 Surface Closer	CPS7500 TBGN	689	NO
1 Closer Drop Plate	7788 (as required)	689	NO
1 Perimeter Seals	Door manufacturer's standard		OT

Set: 4.0

Doors: A406, A420

3 Hinge, Half Surface, Hvy Wt	T4A3782	US26D	MK
1 Storeroom/Closet Lock	LC 8204 LE1L	US26D	SA
1 Cylinder	Match existing	626	SC
1 Electric Strike	1006CS	630	HS ⚡
1 Surface Mount Door Operator (Single) Stanley Magic-Force Series		628	ST ⚡
1 Kick Plate	K1050 10"	US32D	RO
2 SS Door Frame Cover	See section 102600	630	OT
1 Wall Stop	403	US26D	RO
1 Gasketing	S44BL		PE
1 Wave-to-Open Wall Switch	700		NO ⚡
1 Power Supply	Provided by access control		
1 Card Reader	Provided by access control		OT

Notes:

Door normally closed and locked.

Entry by valid credential releasing the electric strike; mechanical key override.

Free egress at all times.

Coordination required for card access and automatic operator use.

Set: 5.0

Doors: A409A

3 Hinge, Half Surface, Hvy Wt	T4A3782	US26D	MK
-------------------------------	---------	-------	----

1 Storeroom/Closet Lock	LC 8204 LE1L	US26D	SA
1 Cylinder	Match existing	626	SC
1 Electric Strike	1006CS	630	HS ⚡
1 Surface Mount Door Operator (Single)		Stanley Magic-Force	
Series	628	ST	⚡
1 Armor Plate	K1050 F 34"	US32D	RO
1 Wall Stop	403	US26D	RO
1 Gasketing	S44BL		PE
1 Wave-to-Open Wall Switch	700		NO ⚡
1 Power Supply	Provided by access control		
1 Card Reader	Provided by access control		OT

Notes:

Door normally closed and locked.

Entry by valid credential releasing the electric strike; mechanical key override.

Free egress at all times.

Coordination required for card access and automatic operator use.

Set: 6.0

Doors: [A415](#), [A437](#)

3 Hinge, Half Surface, Hvy Wt	T4A3782	US26D	MK
1 Access Control Lock (BY DIV 28)	M1-82271-24V-IPS LNL LC	US26D	SA ⚡
1 Cylinder	Match existing	626	SC
1 Surface Closer	7500 TBGN	689	NO
1 Kick Plate	K1050 10"	US32D	RO
1 Wall Stop	403	US26D	RO
1 Gasketing	S44BL		PE
1 Electric Power Transfer	EL-CEPT		SU ⚡
1 Frame Harness	QC-C1500P (as required)		MK ⚡
1 Door Harness	QC-CXXXP (as required)		MK ⚡
1 Power Supply	Provided by access control		

Notes:

Door normally closed and locked.

Entry by valid credential presented to the integrated card reader unlocking the lever on the key side of the door; mechanical key override.

Free egress at all times.

Set: 7.0

Doors: [A421B](#), [A435](#), [A445](#)

3 Hinge, Full Mortise	TA2714 (NRP)	US26D	MK
1 Access Control Lock (BY DIV 28)	M1-82271-24V-IPS LNL LC	US26D	SA ⚡
1 Cylinder	Match existing	626	SC
1 Surface Closer	7500 TBGN	689	NO
1 Kick Plate	K1050 10"	US32D	RO
1 Wall Stop	403	US26D	RO
1 Gasketing	S44BL		PE
1 Electric Power Transfer	EL-CEPT		SU ⚡

1 Frame Harness	QC-C1500P (as required)	MK	⚡
1 Door Harness	QC-CXXXP (as required)	MK	⚡
1 Power Supply	Provided by access control		

Notes:

Door normally closed and locked.

Entry by valid credential presented to the integrated card reader unlocking the lever on the key side of the door; mechanical key override.

Free egress at all times.

Set: 8.0

Doors: [A409B](#)

3 Hinge, Full Mortise	TA2714 (NRP)	US26D	MK
1 Access Control Lock (BY DIV 28)	M1-82271-24V-IPS LNL LC	US26D	SA ⚡
1 Cylinder	Match existing	626	SC
1 Surface Closer	7500 TBGN	689	NO
1 Kick Plate	K1050 10"	US32D	RO
1 Wall Stop	403	US26D	RO
1 Gasketing	S44BL		PE
1 Electric Power Transfer	EL-CEPT		SU ⚡
1 Frame Harness	QC-C1500P (as required)		MK ⚡
1 Door Harness	QC-CXXXP (as required)		MK ⚡
1 Power Supply	Provided by access control		

Notes:

Door normally closed and locked.

Entry by valid credential presented to the integrated card reader unlocking the lever on the key side of the door; mechanical key override.

Free egress at all times.

Set: 9.0

Doors: [A427](#)

3 Hinge, Half Surface, Hvy Wt	T4A3782	US26D	MK
1 Access Control Lock (BY DIV 28)	M1-82271-24V-IPS LNL LC	US26D	SA ⚡
1 Cylinder	Match existing	626	SC
1 Electromechanical Closer	71X0SZ (Fail Safe)	689	NO ⚡
1 Armor Plate	K1050 F 34"	US32D	RO
1 Wall Stop	403	US26D	RO
1 Gasketing	S44BL		PE
1 Electric Power Transfer	EL-CEPT		SU ⚡
1 Frame Harness	QC-C1500P (as required)		MK ⚡
1 Door Harness	QC-CXXXP (as required)		MK ⚡
1 Power Supply	Provided by access control		

Notes:

Door normally closed and locked.

Entry by valid credential presented to the integrated card reader unlocking the lever on the key side of the door; mechanical key override.

Free egress at all times.

Closer holder to be fail safe. Connect to release upon the signal of the fire alarm.

Set: 10.0

Doors: [A446](#)

3 Hinge, Half Surface, Hvy Wt	T4A3782	US26D	MK
1 Access Control Lock (BY DIV 28)	M1-82271-24V-IPS LNL LC	US26D	SA ⚡
1 Cylinder	Match existing	626	SC
1 Surface Overhead Stop	10-X36	630	RF
1 Electromechanical Closer	71X0SZ (Fail Safe)	689	NO ⚡
1 Armor Plate	K1050 F 34"	US32D	RO
1 Gasketing	S44BL		PE
1 Electric Power Transfer	EL-CEPT		SU ⚡
1 Frame Harness	QC-C1500P (as required)		MK ⚡
1 Door Harness	QC-CXXXP (as required)		MK ⚡
1 Power Supply	Provided by access control		

Notes:

Door normally closed and locked.

Entry by valid credential presented to the integrated card reader unlocking the lever on the key side of the door; mechanical key override.

Free egress at all times.

Closer holder to be fail safe. Connect to release upon the signal of the fire alarm.

Set: 11.0

Doors: [A430](#), [A436](#),

3 Hinge, Half Surface, Hvy Wt	T4A3782	US26D	MK
1 Passage Latch	8215 LE1L	US26D	SA
1 Electric Strike	1006CS	630	HS ⚡
1 Surface Mount Door Operator (Single) Stanley Magic-Force Series		628	ST ⚡
1 Armor Plate	K1050 F 34"	US32D	RO
1 Wall Stop	403	US26D	RO
1 Gasketing	S44BL		PE
2 Wave-to-Open Wall Switch	700		NO ⚡
1 Power Supply	Provided by access control		

Set: 11.1

Doors: [A464](#), [A465](#)

3 Hinge, Half Surface, Hvy Wt	T4A3782	US26D	MK
1 Passage Latch	8215 LE1L	US26D	SA
1 Electric Strike	1006CS	630	HS ⚡
1 Surface Mount Door Operator (Single) Stanley Magic-Force Series		628	ST ⚡
1 Armor Plate	K1050 F 34"	US32D	RO
1 Wall Stop	403	US26D	RO
1 Gasketing	S44BL		PE

1 Door Bottom	STC411APK		PE
1 Wave-to-Open Wall Switch	700		NO ⚡
1 Power Supply	Provided by access control		

Set: 12.0

Doors: [A456](#)

6 Hinge, Half Surface, Hvy Wt	T4A3782	US26D	MK
1 Automatic Flush Bolt	2840	US26D	RO
1 Hospital Passage Latch	8215 ALP	US32D	SA
1 Electric Strike	1006CS	630	HS ⚡
1 Surface Door Operator (Pair)	Stanley Magic-Force Series	628	ST ⚡
2 Armor Plate	K1050 34"	US32D	RO
2 Wall Stop	403	US26D	RO
1 Gasketing	S44BL		PE
1 Meeting Stile Seal	S771C		PE
1 Electric Power Transfer	EL-CEPT		SU ⚡
1 Frame Harness	QC-C1500P (as required)		MK ⚡
1 Door Harness	QC-CXXXP (as required)		MK ⚡
2 Wave-to-Open Wall Switch	700		NO ⚡
1 Power Supply	Provided by access control		

Set: 13.0

Doors: [A414](#), [A429](#)

3 Hinge, Full Mortise	TA2714 (NRP)	US26D	MK
1 Storeroom/Closet Lock	LC 8204 LE1L	US26D	SA
1 Cylinder	Match existing	626	SC
1 Surface Closer	7500 TBGN	689	NO
1 Kick Plate	K1050 10"	US32D	RO
1 Wall Stop	403	US26D	RO
1 Gasketing	S44BL		PE

Set: 14.0

Doors: [A441](#), [A444A](#), [A444B](#)

3 Hinge, Full Mortise	TA2714 (NRP)	US26D	MK
1 Office/Entry Lock	LC 8205 LE1L	US26D	SA
1 Cylinder	Match existing	626	SC
1 Wall Stop	403	US26D	RO
1 Gasketing	S44BL		PE

Set: 15.0

Doors: [A403A](#)

3 Hinge, Full Mortise	TA2714 (NRP)	US26D	MK
1 Office/Entry Lock	LC 8205 LE1L	US26D	SA
1 Cylinder	Match existing	626	SC
1 Surface Closer	7500 TBGN	689	NO
1 Kick Plate	K1050 10"	US32D	RO

1 Wall Stop	403	US26D	RO
1 Gasketing	S44BL		PE

Set: 16.0Doors: [A408](#), [A410](#), [A416](#), [A423](#), [A428](#), [A451](#)

3 Hinge, Full Mortise	TA2714	US26D	MK
1 Privacy Lock w/DbI Occ Ind	V21 8266 LNL	US26D	SA
1 Surface Closer	7500 TBGN	689	NO
1 Kick Plate	K1050 10"	US32D	RO
1 Wall Stop	403	US26D	RO
1 Gasketing	S44BL		PE

Set: 17.0Doors: [A402](#)

3 Hinge, Full Mortise	TA2714	US26D	MK
1 Passage Latch	8215 LE1L	US26D	SA
1 Surface Overhead Stop	10-X36	630	RF
1 Gasketing	S44BL		PE

Set: 18.0Doors: [A401](#), [A421A](#), [A452](#)

3 Hinge, Full Mortise	TA2714	US26D	MK
1 Passage Latch	8215 LE1L	US26D	SA
1 Surface Closer	7500 TBGN	689	NO
1 Kick Plate	K1050 10"	US32D	RO
1 Wall Stop	403	US26D	RO
1 Gasketing	S44BL		PE

Set: 19.0Doors: [A417](#), [A424](#)

3 Hinge, Full Mortise	TA2714	US26D	MK
1 Push Plate	70C-RKW	US32D	RO
1 Pull Plate	BF 111x70C	US32D	RO
1 Surface Overhead Stop	10-X36	630	RF
1 Surface Closer	7500 TBGN	689	NO
1 Kick Plate	K1050 10"	US32D	RO
3 Silencer	608-RKW		RO

Set: 20.0Doors: [A431](#), [A448](#), [A461](#)

6 Hinge, Half Surface, Hvy Wt	T4A3782	US26D	MK
1 Self Latching Flush Bolt	2805	US26D	RO
1 Hospital Passage Latch	8215 ALP	US32D	SA
2 Surface Overhead Hold Open	9-X26	630	RF
1 Surface Closer	7500 TBGN	689	NO
2 Armor Plate	K1050 34"	US32D	RO

2 SS Door Frame Cover	See section 102600	630	OT
1 Gasketing	S44BL		PE
2 Door Bottom	STC411APK		PE
1 Meeting Stile Seal	S771C		PE
2 Edge Guard (lock/strike edge)	306B (match armor plate height)	US32D	RO
2 Edge Guard (hinge edge)	304 (match armor plate height)	US32D	BU

Set: 21.0

Doors: A470

1 Electric Strike	9500/9600-LBM	630	HS ⚡
1 Power Supply	Provided by access control		
1 Card Reader	Provided by access control		OT

Notes:

Verify compatibility and functionality of specified hardware with existing conditions.
Verify balance of existing hardware is in good condition and installed correctly.

Set: 22.0

Doors: A403B

1 Hardware	By door manufacturer		
------------	----------------------	--	--

END OF SECTION 087100

SECTION 08 80 00 – GLAZING**PART 1 - GENERAL****1.1 SUMMARY**

- A. Furnish labor, materials, tools, equipment, and services for Interior Glass and Glazing in accordance with provisions of Contract Documents.
- B. Completely coordinate with work of other trades.

1.2 QUALITY ASSURANCE

- A. Glass Standards:
 - 1. ANSI Z97.1.
 - 2. CPSC 16 CFR 1201.
 - 3. GANA Glazing Manual.
- B. Flat Glass ASTM C1036.
 - 1. Float glass: Type I, Quality q3 and Class 1 unless otherwise indicated.
 - 2. Figured glass: Type II, Quality q7, Form 3 and Class 1, Finish f1 and Pattern p2 unless otherwise indicated.
 - 3. Mirror glass and one-way vision glass: Type I, Quality q1 or q2, Class 1 and coated for purpose.
- C. Flat Glass, Heat Treated, Coated and Uncoated, ASTM C1048.
 - 1. Heat strengthened glass: Kind HS, Type I, Quality q3, Class 1 and Condition A unless otherwise indicated.
 - 2. Tempered glass: Kind FT, Type I, Quality q3, Class 1 and Condition A unless otherwise indicated.
- D. Mirror Glass:
 - 1. ASTM C1503;
 - 2. Quality: Mirror select.
 - 3. F.S.DD-M-00411B (1).
- E. Fire-Rated Assemblies:
 - 1. General:
 - a. Where glazing products are used in fire-rated assemblies, comply with requirements of specific assembly specified in other sections of these Specifications.
 - b. Underwriters Laboratories, Inc. (UL):
 - 1) UL 9 – Fire Tests of Window Assemblies.
 - 2) UL 10B – Fire Tests of Door Assemblies.
 - 3) UL 10C – Positive Pressure Fire Tests of Door Assemblies.
 - c. Fire Protective Rated Glass: Each lite shall bear permanent, non-removable label of UL certifying it for use in tested and rated fire protective assemblies.
 - 2. Door Assemblies:
 - a. Complying with NFPA 80 and listed and labeled by a testing and inspecting agency acceptable to authorities having jurisdiction, for fire ratings indicated, based on testing according to NFPA 252.
 - b. Positive Pressure Compliance: UL 10C.
 - c. Fire Protective Glazing Products for Door Assemblies: Products identical to those tested per UL 10B, labeled and listed by UL.

3. Window Assemblies:
 - a. Complying with NFPA 80 that are listed and labeled by a testing and inspecting agency acceptable to authorities having jurisdiction, for fire ratings indicated, based on testing according to NFPA 257.
 - b. Positive Pressure Compliance: UL 10C.
- F. Laminated Glass:
 1. ASTM C1172 Standard Specification for Laminated Architectural Flat Glass.
 2. Laminated Glass Design Guide, by the Glass Association of North America (GANA).
- G. Glazing Standards:
 1. Glazing Manual, by the Glass Association of North America (GANA).

1.3 SUBMITTALS

- A. Samples:
 1. Provide one (1) 12 IN x 12 IN example of each specified type of glass.
- B. Contract Closeout Information:
 1. Warranties.
- C. Smoke baffle system:
 1. Shop drawing details, plans and elevations showing supports to building structure, interface at ceiling, blocking, baffle shoe, cap rail, grommet, cladding, sealant/adhesive, and glass.
 2. Product data.
 3. Standard warranty.
 4. Installation Instructions

1.4 WARRANTY

- A. Written warranty signed by manufacturer or fabricator.
- B. Laminated Glass:
 1. Five (5) years against deterioration including edge separation, delamination that materially obstructs vision through glass, and blemishes exceeding those allowed by referenced laminated-glass standard.
- C. Fire-rated Ceramics:
 1. Five (5) year manufacturer's standard warranty.

PART 2 - PRODUCTS

2.1 ACCEPTABLE MANUFACTURERS

- A. Glass Products:
 1. Base:
 - a. AGC Industries.
 - b. Other manufacturers listed under (GLI) on Interior Finish Schedule drawing I-001
 2. Optional:
 - a. Guardian Industries.
 - b. Pilkington.
 - c. PPG Industries.
 - d. Saint-Gobain.
- B. Fire-rated Glass Ceramic:
 1. Base:
 - a. Technical Glass Products.

2. Optional:
 - a. Saffi First.
 - b. Pilkington.
 - c. Saint-Gobain.
- C. Radiation-resistant Glass:
 1. Base:
 - a. Ray-Bar Engineering Corp.
 2. Optional:
 - a. Nelco.
 - b. Corning Inc.
 - c. Schott North America, Inc.
 - d. Radiation Protection Products (RPP).
- D. Smoke Baffle System:
 1. Base design: CRL / Blumcraft (C.R. Laurence Co. Architectural Products)
 2. Optional: Approved equal.

2.2 MATERIALS

- A. Glass Materials:
 1. Comply with indicated standards.
 2. See Glass Types Schedule for listing of types.
 3. Materials specified in Glass Types Schedules are minimum acceptable products.
 4. Single manufacturer produce individual glass types used in fabrication of insulating units.
 5. Manufacturer or fabricator determine if materials should be heat strengthened or fully tempered at non-hazardous locations that do not require safety glazing and provide accordingly.
- B. Glazing Compounds:
 1. Nonsag, nonstain type.
 2. Pigmented to match frame units not requiring painting.
 3. Compatible with adjacent surfaces.
 4. For use in setting glass: Neutral-cure Silicone sealant.
 5. Sealants:
 - a. Sealants shall have a VOC content no greater than 250 g/L.
 - b. Sealants shall contain no carcinogen or reproductive toxicant components present at more than 1% of total mass of the product as defined in the California Office of Environmental Health Hazard Assessment's (OEHHA) list entitled "Chemicals Known to the State to Cause Cancer" or the Reproductive Toxicity, Safe Drinking Water and Toxic Enforcement Act of 1986 (Proposition 65).
 6. Sealant tape:
 - a. Butyl rubber sealant tape or ribbon having a continuous neoprene shim.
 7. Gaskets:
 - a. Polyvinyl chloride or neoprene.
 - b. Extruded, flexible, of profile and hardness required to receive glass and provide a watertight installation.
- C. Installation Setting Blocks and Spacers:
 1. Neoprene, compatible with sealants used.
 2. Setting blocks: 80-90 durometer.
 3. Spacers: 40-50 durometer.
 4. Compressible filler stock: Closed cell jacketed rod stock of synthetic rubber or plastic foam.

5. Shims, clips, springs, angles, beads, attachment screws and other miscellaneous items: As indicated or required.

2.3 GLASS TYPES SCHEDULE

- A. Refer to Interior Glass Types Schedule and Interior Finish Schedule for basic description of Mark Numbers indicated on Drawing.
- B. Refer to Drawings for depiction of unit sizes and locations.
- C. Upgrade basic type conditions in accordance with following rules:
 1. Heat treatment upgrade based on physical size of unit:
 - a. Heat strengthened or fully tempered units between 55 and 70 SF.
 - b. Fully temper units exceeding 70 SF.
 - c. Strengthen annealed glass where units exceed length or width limitations or both as recommended by glass manufacturer.
 2. Heat treatment upgrade based on locations which are potentially hazardous to occupants:
 - a. Upgrade units to fully tempered, Kind FT, glass as required by any one of following:
 - 1) When required by local Codes.
 - 2) When specifically indicated on Drawings.
 - 3) Locations requiring Safety Glass, Kind FT, by 16 CFR 1201 and ANSI Z97.1:
 - a) Units installed in doors, sash, transom or other operable units.
 - b) Units where any part of unit is within 18 IN, measured vertically, above a floor line, sidewalk, paver, or other walking surface located within 3 FT of the glass unit, measured horizontally.
 - 4) Units in sidelights and other units located adjacent to and within 48 IN of either jamb of door or other operable units; this includes adjacent lites that are in perpendicular plane to door.
 3. Other conditions requiring heat treatment upgrades:
 - a. Units which will be exposed to irregular sun or shade combinations or both shall be Kind HS or better.
 - b. Where glass manufacturer recommends heat treatment coatings or tints specified.
 - c. Where required to resist lateral loads.

2.4 INTERIOR GLASS TYPES

- A. Annealed:**
 1. Clear float, 6mm (1/4 IN) thick.
- B. Tempered:**
 1. Clear, fully-tempered tongue-less float, 6mm (1/4 IN) thick.
- C. Laminated Fire and Safety Glass, 8mm:**
 1. Laminated, wireless, UL labeled for assembly indicated.
 2. Impact-Safety Rated per ANSI Z97.1 and CPSC 16CFR1201.
 3. Thickness: 8mm (5/16 IN), laminated.
 4. Surface: Polished.
 5. Base Product: FireLite Plus by Technical Glass Products.
- D. Mirror Glass:**
 1. Color: Clear.
 2. Thickness: 6mm (1/4 IN).
 3. Unit Length and Width: As indicated on drawings.
 4. Annealed
 5. Tempered.

E. Radiation-Resistant Glazing:

1. Composition: Lead-barium, polished float glass containing not less than 60 percent heavy metal oxides, including not less than 48 percent lead oxide by weight.
2. Color: Clear.
3. Provide glass units of sufficient thickness to provide same radiation shielding as adjacent wall areas. Provide single or multiple plies as necessary.

F. Laminated, Heat-Strengthened Glass:

1. Laminated safety glass complying with ANSI Z97.1 and CPSC 16 CFR 1201, consisting of 2 sheets of heat strengthened float glass ASTM C1036, and 60 mil interlayer.

2.5 SMOKE BAFFLE SYSTEM**A. Smoke Baffle, 1/2 IN tempered glass smoke curtain. System includes:**

1. Mounting brackets;
2. Snap-in inserts, pins inserts, bushings, cladding and mounting screws, as required.
3. 1/2 IN flat polished glass edges, at vertical and horizontal exposed surfaces.

PART 3 - EXECUTION**3.1 INSPECTION**

- A. Examine framing or glazing channel surfaces, backing, stop design, and conditions under which glazing is to be installed.

3.2 INSTALLATION

- A. Do not install glass with edge damage.
- B. Contractor is responsible for correct glass size for each opening, within tolerances and dimensions established.
- C. Comply with recommendations of manufacturers, except where more stringent requirements are indicated.
- D. Comply with GANA Glazing Manual.
- E. Install sealants as recommended by sealant manufacturer.
- F. Install setting blocks in adhesive or sealant.
- G. Provide spacers inside and out, of proper size and spacing, for glass size, except where gaskets are used for glazing.
- H. Minimum Bite:
 1. Monolithic, 6mm (1/4 IN) glass: 3/8 IN minimum bite.
 2. For other sizes: Refer to Table C of AAMA's Aluminum Curtain Wall Design Manual, Volume 6, Glass and Glazing.
- I. Sealant Depth: Equal to sealant width.
- J. Prevent sealant exudation from glazing channels.
 1. Leave void at heel or install filler at jambs and head.
 2. Do not leave void or install filler at sill.
- K. Miter cut and bond gasket ends together at corners.
- L. Immediately after installation, attach crossed streamers to framing held away from glass.
- M. Do not apply anything to surfaces of glass.

- N. Install spandrel units from exterior of building.
- O. Installation of Mirrors:
 - 1. Mastic Attachment: Install mirrors with mirror adhesive applied to back of mirror and pressed against substrate as recommended by mirror supplier.
- P. Remove and replace damaged glass.
- Q. Installation smoke baffle systems:
 - 1. Install in accordance with approved shop drawings.
 - 2. Follow manufacturers installation instructions.

3.3 CLEANING AND PROTECTION

- A. Wash and polish glass on both faces not more than 7 days prior to final completion of work in each area.
- B. Comply with glass manufacturer's recommendations and GANA 01-0300.

END OF SECTION

SECTION 08 88 59 - INSULATING GLASS UNITS WITH INTEGRATED BLINDS**GENERAL**

1.1 SUMMARY

- A. Section Includes:
 - 1. Insulating glass and blind assemblies with integrated horizontal blinds.
- B. Related Sections:
 - 1. Division 01: Administrative, procedural, and temporary work requirements.
 - 2. Section 08 11 13 - Hollow Metal Doors and Frames
 - 3. Section 08 14 16 - Flush Wood Doors
 - 4. Section 08 80 00 - Glazing.

1.2 REFERENCES

- A. American National Standards Institute (ANSI) Z97.1 - Safety Performance Specifications and Methods of Test for Safety Glazing Material Used in Buildings.
- B. American Society of Civil Engineers (ASCE) 7 - Minimum Design Loads for Buildings and Other Structures.
- C. ASTM International (ASTM):
 - 1. C1048 - Standard Specification for Heat-Treated Flat Glass-Kind HS, Kind FT Coated and Uncoated Glass.
 - 2. C1172 - Standard Specification for Laminated Architectural Flat Glass.
 - 3. E330 - Standard Test Method for Structural Performance of Exterior Windows, Curtain Walls, and Doors by Uniform Static Air Pressure Difference.
 - 4. E1300 - Standard Practice for Determining Load Resistance of Glass in Buildings.
 - 5. E2190 - Standard Specification for Insulating Glass Unit Performance and Evaluation.
- D. Consumer Product Safety Commission (CPSC) 16 CFR 1201 - Safety Standard for Architectural Glazing Materials.
- E. Underwriters Laboratories (UL) / Underwriters Laboratories of Canada (ULC)
 - 1. Product Directories.
 - 2. 9 - Standard for Fire Tests of Window Assemblies.
 - 3. 10B - Standard for Fire Tests of Door Assemblies.
 - 4. 10C - Standard for Positive Pressure Fire Tests of Door Assemblies.

1.3 SYSTEM DESCRIPTION

- A. Glass Thickness for Exterior Locations:
 - 1. Indicated thicknesses are minimums; select actual glass thicknesses by analyzing loads and conditions.
 - 2. Size glass to withstand positive and negative wind pressure acting normal to plane in accordance with [ASCE 7] [IBC] as measured in accordance with ASTM E330.
 - 3. Provide glass in thicknesses and strengths to meet or exceed following criteria:
 - a. Comply with ASTM E1300.
 - b. Probability of breakage: [8] lites per 1000 under wind load for load duration of [3] seconds.

- c. Thickness of tinted glass: Provide same thickness for each tint color for all applications.

1.4 SUBMITTALS

- A. Submittals for Review:
 1. Shop Drawings: Include elevations and details showing insulating glass units with integrated blind assembly locations, sizes, control types, [power supply and locations,] and installation details.
 2. Product Data: Include product description, operation and controls, materials, and finishes.
 3. Samples: Slat samples showing available colors.
 4. Warranty: Sample warranty statement.
- B. Quality Control Submittals:
 1. Certificates of Compliance: Manufacturer's certification that products furnished comply with specified requirements.

1.5 QUALITY ASSURANCE

- A. Obtain integrated glass and blind assemblies from single manufacturer.
- B. Glass and blind components supplied by single manufacturer.
- C. Installer Qualifications: Minimum [2] years experience in work of this Section.
- D. Mockup:
 1. Size: Minimum [2 x 2] feet [610 x 610] mm.
 2. Show insulating glass units with integrated blind assembly and controls.
 3. Locate where directed.
 4. Approved mockup may not remain as part of the Work.
- E. Regulatory Requirements:
 1. Provide tempered or laminated safety glass for locations subject to human impact as required by [IBC.]
 2. Safety glass: Tested and labeled to CPSC 16 CFR 1201.
- F. Fire Rated Glass Assemblies: Tested to UL 9, UL 10B, and UL 10C.
- G. Electrical Components: Listed by [UL.]

1.6 DELIVERY, STORAGE AND HANDLING

- A. Deliver insulating glass units with integrated blind assemblies with temporary label on each unit identifying manufacturer, glass type, glass quality, and nominal glass thickness.
- B. Keep crates upright, covered, in ventilated, dry, and safe location.
- C. Store individual units upright, on blocks, in safe and dry location.
 1. Do not store in stacks or in direct sunlight.
 2. Provide base to support component lites of unit so that individual lites will not slide out of alignment or out of square.
- D. Protect edges and corners by use of corner protectors.

1.7 PROJECT CONDITIONS

- A. Maintain temperature, humidity, and ventilation within limits recommended by manufacturer.
- B. Do not install products under environmental conditions outside manufacturer's limits.

1.8 WARRANTIES

- A. Insulating Glass Units with Integrated Blind Assemblies: Provide glass assembly manufacturer's [10] year warranty providing coverage against material obstruction of glass units by dust or film formation due to failure of hermetic seal.
- B. Fire-Rated Glass: Provide glass manufacturer's 5 year warranty providing coverage against manufacturing defects resulting in material obstruction through glass, glass edge separation, and changes in properties of interlayer.

PART 2 PRODUCTS

2.1 MANUFACTURERS

- A. Contract Documents are based on ViuLite by Unicel Architectural Corp., 2155 Fernand-Lafontaine Boulevard, Longueuil, Quebec, J4G 2J4 Canada, 450-670-6844, unicel@unicelarchitectural.com, (www.viulite.com)
- B. Substitutions: [Under provisions of Division 01.] [Not permitted.]

2.2 MATERIALS - GLAZING

- A. Clear Tempered Glass: ASTM C1048, Type 1 transparent flat, Class 1 clear, Quality q3 glazing select, Kind FT fully tempered.

2.3 MATERIALS - BLINDS

- A. Head Rail:
 - 1. Description: Extruded aluminum, 20 mm wide x 55 mm high, with 5 mm pelmet to reduce light passing between first slat and head rail.
 - 2. Finish: Powder coated to coordinate with slats.
 - 3. Color: [To be selected from manufacturer's full color range.]
- B. Slats:
 - 1. Description: Aluminum, 12.5 mm wide x 0.2 mm thick.
 - 2. Finish: High-resistance polyester paint, non-fogging.
 - 3. Color: [To be selected from manufacturer's full color range.]
- C. Bottom Rail:
 - 1. Description: Extruded aluminum, two interlocking profiles, 14 mm wide x 10 mm high.
 - 2. Finish: High-resistance powder coated.
 - 3. Color: [To be selected from manufacturer's full color range.]
- D. Ladder Tape:
 - 1. Description: Thermo-fixed 100 percent polyester, 10 mm pitch, treated to prevent release of chemical products inside insulating glass.
 - 2. Color: Coordinated with slats.

- E. Internal Cord: Thermo-fixed 100 polyester, 1.0 mm diameter, with high resistance internal core, white.

2.4 MATERIALS - GLASS SPACER BARS

- A. Spacer Bars: Extruded aluminum.

2.5 MATERIALS - OPERATORS AND CONTROLS

- A. Internally Mounted Motor: Activation of wall switch or remote control activates blind rotation and lifting.

2.6 MOTORS

- A. Internal Motor:
 1. Power supply voltage: 24 V DC, maximum consumption 0.45A.
 2. Motor: Brushless slotted sensed rotor with four rare-earth magnet poles.
 3. Planetary reducer:
 - a. Steel, High-resistance, hardened and self-lubricated sintered gears.
 - b. Satellite holder with rolls in steel, external rim in steel broach; double bearing at outlet.
 4. Corner keys: Patented corner keys; corner key fitted on motor side equipped with integrated contacts.
 5. External connector: Three-pole connector, gold-plated terminals.
 6. Electronic card: Minus 4 to plus 194 degrees F (Minus 20 to plus 90 degrees C) operating range; control encoder, speed limiter, and motor safety function.
 7. Accessories:
 - a. Dedicated switching power supplier.
 - b. Control unit.
 - c. Control unit with radio receiver.
 - d. Radio remote control; [white.] [gray.]
 - e. Control unit with KNX interface.

2.7 ACCESSORIES

- A. Glazing Accessories: Specified in Section 08 80 00.

2.8 FABRICATION

- A. Sealed Insulating Glass:
 1. Factory assembled, consisting of sealed glass panes separated by dehydrated interspaces, to ASTM E2190.
 2. Fabricate units in required sizes with edge and face clearances, edge and surface conditions, and bite in accordance with manufacturer requirements and reference standards, to comply with system performance requirements.
 3. Bond spacer bar frame to glass panes with dual sealing system.
 4. Fill space outside frame to glass edge with elastomeric sealant.
- B. Glass Identification:
 1. Apply manufacturer's label indicating type and thickness to each light of glass. Show position of exterior face when installed.
 2. Etch manufacturer's label on each light of tempered glass.

PART 3 EXECUTION

3.1 EXAMINATION

- A. Verify that openings:
 - 1. Conform to details; dimensions, and tolerances indicated on approved Shop Drawings.
 - 2. Are constructed to support weight of glass without deformation.
 - 3. Are level, plumb, square, in plane, and free of obstructions.
 - 4. Have joints sealed to prevent water and air infiltration, with weep holes to exterior.

3.2 PREPARATION

- A. Clean surfaces to receive glass units prior to installation.
- B. Prepare surfaces using methods recommended by manufacturer.

3.3 INSTALLATION

- A. Install in accordance with manufacturer's instructions and approved Shop Drawings.
- B. Follow provisions of Section 08 80 00 as applicable to glazing installation method.
- C. Set glazing without bending, twisting, or forcing of units.
- D. Do not allow glass to rest on or contact framing members.
- E. Install power supply and control units. Connect to power supply and control wiring.
- F. Locate wall switches where directed by Architect.

3.4 CLEANING

- A. Clean glass surfaces; remove temporary labels and foreign matter.

3.5 ADJUSTING

- A. Replace cracked, broken, and damaged glass, and glass that has been improperly installed.

3.6 PROTECTION

- A. Protect installed products until completion of project.

3.7 SCHEDULE

BLIND DESIGNATION	EXTERIOR LITE	INTERIOR PANE	OPERATOR	FUNCTION
None	6 mm thick, clear, tempered	6 mm thick, clear, tempered	Internal motor, wall switch	Tilt and raise

END OF SECTION

SECTION 09 22 16 - NON-STRUCTURAL METAL FRAMING

PART 1 - GENERAL

1.1 RELATED DOCUMENTS

- A. Drawings and general provisions of the Contract, including General and Supplementary Conditions and Division 01 Specification Sections, apply to this Section.

1.2 SUMMARY

- A. Section Includes:
 - 1. Non-load-bearing steel framing systems for interior gypsum board assemblies.
 - 2. Suspension systems for interior gypsum ceilings, soffits, and grid systems.
- B. Related Requirements:
 - 1. Section 054000 "Cold-Formed Metal Framing" for exterior and interior load-bearing and exterior non-load-bearing wall studs; floor joists; roof rafters and ceiling joists; and roof trusses.

1.3 SUBMITTALS

- A. Product Data: For each type of product.

PART 2 - PRODUCTS

2.1 PERFORMANCE REQUIREMENTS

- A. Fire-Test-Response Characteristics: For fire-resistance-rated assemblies that incorporate non-load-bearing steel framing, provide materials and construction identical to those tested in assembly indicated, according to ASTM E 119 by an independent testing agency.
- B. STC-Rated Assemblies: For STC-rated assemblies, provide materials and construction identical to those tested in assembly indicated, according to ASTM E 90 and classified according to ASTM E 413 by an independent testing agency.

2.2 FRAMING SYSTEMS

- A. Framing Members, General: Comply with ASTM C 754 for conditions indicated.
 - 1. Steel Sheet Components: Comply with ASTM C 645 requirements for metal unless otherwise indicated.
 - 2. Protective Coating: ASTM A 653/A 653M, G40 (Z120) hot-dip galvanized unless otherwise indicated.

- B. Studs and Runners: ASTM C 645. Use either steel studs and runners or dimpled steel studs and runners.
 - 1. Steel Studs and Runners (or Dimpled Steel Studs and Runners):
 - a. Thickness: 30 Mil (structural); minimum, unless noted otherwise. Use 16 GA studs at lead lined walls.
 - b. Depth: As indicated on Drawings.
- C. Slip-Type Head Joints: Where indicated, provide one of the following:
 - 1. Single Long-Leg Runner System: ASTM C 645 top runner with 2-inch- (51-mm-) deep flanges in thickness not less than indicated for studs, installed with studs friction fit into top runner and with continuous bridging located within 12 inches (305 mm) of the top of studs to provide lateral bracing.
 - 2. Deflection Track: Steel sheet top runner manufactured to prevent cracking of finishes applied to interior partition framing resulting from deflection of structure above; in thickness not less than indicated for studs and in width to accommodate depth of studs.
- D. Flat Strap and Backing Plate: Steel sheet for blocking and bracing in length and width indicated.
 - 1. Minimum Base-Metal Thickness: As indicated on Drawings.
- E. Cold-Rolled Channel Bridging: Steel, 0.053-inch (1.34-mm) minimum base-metal thickness, with minimum 1/2-inch- (13-mm-) wide flanges.
 - 1. Depth: 1-1/2 inches (38 mm).
 - 2. Clip Angle: Not less than 1-1/2 by 1-1/2 inches (38 by 38 mm), 0.068-inch- (1.72-mm-) thick, galvanized steel.
- F. Hat-Shaped, Rigid Furring Channels: ASTM C 645.
 - 1. Minimum Base-Metal Thickness: 0.033 inch (0.84 mm).
 - 2. Depth: 7/8 inch (22.2 mm).
- G. Resilient Furring Channels: 1/2-inch- (13-mm-) deep, steel sheet members designed to reduce sound transmission.
 - 1. Configuration: hat shaped.
- H. Cold-Rolled Furring Channels: 0.053-inch (1.34-mm) uncoated-steel thickness, with minimum 1/2-inch- (13-mm-) wide flanges.
 - 1. Depth: 3/4 inch (19 mm).
 - 2. Furring Brackets: Adjustable, corrugated-edge type of steel sheet with minimum uncoated-steel thickness of 0.033 inch (0.8 mm).
 - 3. Tie Wire: ASTM A 641/A 641M, Class 1 zinc coating, soft temper, 0.062-inch- (1.59-mm-) diameter wire, or double strand of 0.048-inch- (1.21-mm-) diameter wire.

2.3 SUSPENSION SYSTEMS

- A. Tie Wire: ASTM A 641/A 641M, Class 1 zinc coating, soft temper, 0.062-inch- (1.59-mm-) diameter wire, or double strand of 0.048-inch- (1.21-mm-) diameter wire.
- B. Hanger Attachments to Concrete:

1. Anchors: Fabricated from corrosion-resistant materials with holes or loops for attaching wire hangers and capable of sustaining, without failure, a load equal to 5 times that imposed by construction as determined by testing according to ASTM E 488 by an independent testing agency.
 - a. Type: Post-installed, expansion anchor.
 2. Powder-Actuated Fasteners: Suitable for application indicated, fabricated from corrosion-resistant materials with clips or other devices for attaching hangers of type indicated, and capable of sustaining, without failure, a load equal to 10 times that imposed by construction as determined by testing according to ASTM E 1190 by an independent testing agency.
- C. Wire Hangers: ASTM A 641/A 641M, Class 1 zinc coating, soft temper, 0.16 inch (4.12 mm) in diameter.
- D. Carrying Channels: Cold-rolled, commercial-steel sheet with a base-metal thickness of 0.053 inch (1.34 mm) and minimum 1/2-inch- (13-mm-) wide flanges.
 1. Depth: 1-1/2 inches (38 mm).
- E. Furring Channels (Furring Members):
1. Cold-Rolled Channels: 0.053-inch (1.34-mm) uncoated-steel thickness, with minimum 1/2-inch- (13-mm-) wide flanges, 3/4 inch (19 mm) deep.
 2. Steel Studs and Runners: ASTM C 645.
 - a. Minimum Base-Metal Thickness: 0.033 inch (0.84 mm), unless noted otherwise.
 - b. Depth: 1-5/8 inches (41 mm) unless noted otherwise.
 3. Hat-Shaped, Rigid Furring Channels: ASTM C 645, 7/8 inch (22 mm) deep.
 - a. Minimum Base-Metal Thickness: 0.033 inch (0.84 mm).
 4. Resilient Furring Channels: 1/2-inch- (13-mm-) deep members designed to reduce sound transmission.
 - a. Configuration: hat shaped.
- F. Grid Suspension System for Gypsum Board Ceilings: ASTM C 645, direct-hung system composed of main beams and cross-furring members that interlock.
 1. Products: Subject to compliance with requirements, provide one of the following:
 - a. Armstrong World Industries, Inc.; Drywall Grid Systems.
 - b. Chicago Metallic Corporation; Drywall Grid System.
 - c. USG Corporation; Drywall Suspension System.

2.4 AUXILIARY MATERIALS

- A. General: Provide auxiliary materials that comply with referenced installation standards.
1. Fasteners for Metal Framing: Of type, material, size, corrosion resistance, holding power, and other properties required to fasten steel members to substrates.

PART 3 - EXECUTION

3.1 EXAMINATION

- A. Examine areas and substrates, with Installer present, and including welded hollow-metal frames, cast-in anchors, and structural framing, for compliance with requirements and other conditions affecting performance of the Work.
- B. Proceed with installation only after unsatisfactory conditions have been corrected.

3.2 PREPARATION

- A. Suspended Assemblies: Coordinate installation of suspension systems with installation of overhead structure to ensure that inserts and other provisions for anchorages to building structure have been installed to receive hangers at spacing required to support the Work and that hangers will develop their full strength.
 - 1. Furnish concrete inserts and other devices indicated to other trades for installation in advance of time needed for coordination and construction.

3.3 INSTALLATION, GENERAL

- A. Installation Standard: ASTM C 754.
 - 1. Gypsum Plaster Assemblies: Also comply with requirements in ASTM C 841 that apply to framing installation.
 - 2. Portland Cement Plaster Assemblies: Also comply with requirements in ASTM C 1063 that apply to framing installation.
 - 3. Gypsum Veneer Plaster Assemblies: Also comply with requirements in ASTM C 844 that apply to framing installation.
 - 4. Gypsum Board Assemblies: Also comply with requirements in ASTM C 840 that apply to framing installation.
- B. Install supplementary framing, and blocking to support fixtures, equipment services, heavy trim, grab bars, toilet accessories, furnishings, or similar construction.
- C. Install bracing at terminations in assemblies.
- D. Do not bridge building control and expansion joints with non-load-bearing steel framing members. Frame both sides of joints independently.

3.4 INSTALLING FRAMED ASSEMBLIES

- A. Install framing system components according to spacings indicated, but not greater than spacings required by referenced installation standards for assembly types.
 - 1. Single-Layer Application: 16 inches (406 mm) o.c. unless otherwise indicated.
 - 2. Multilayer Application: 16 inches (406 mm) o.c. unless otherwise indicated.
 - 3. Tile Backing Panels: 16 inches (406 mm) o.c. unless otherwise indicated.

- B. Where studs are installed directly against exterior masonry walls or dissimilar metals at exterior walls, install isolation strip between studs and exterior wall.
- C. Install studs so flanges within framing system point in same direction.
- D. Install tracks (runners) at floors and overhead supports. Extend framing full height to structural supports or substrates above suspended ceilings except where partitions are indicated to terminate at suspended ceilings. Continue framing around ducts penetrating partitions above ceiling.
 - 1. Slip-Type Head Joints: Where framing extends to overhead structural supports, install to produce joints at tops of framing systems that prevent axial loading of finished assemblies.
 - 2. Door Openings: Screw vertical studs at jambs to jamb anchor clips on door frames; install runner track section (for cripple studs) at head and secure to jamb studs.
 - a. Install two studs at each jamb unless otherwise indicated.
 - b. Install cripple studs at head adjacent to each jamb stud, with a minimum 1/2-inch (13-mm) clearance from jamb stud to allow for installation of control joint in finished assembly.
 - c. Extend jamb studs through suspended ceilings and attach to underside of overhead structure.
 - 3. Other Framed Openings: Frame openings other than door openings the same as required for door openings unless otherwise indicated. Install framing below sills of openings to match framing required above door heads.
 - 4. Fire-Resistance-Rated Partitions: Install framing to comply with fire-resistance-rated assembly indicated and support closures and to make partitions continuous from floor to underside of solid structure.
 - a. Firestop Track: Where indicated, install to maintain continuity of fire-resistance-rated assembly indicated.
 - 5. Sound-Rated Partitions: Install framing to comply with sound-rated assembly indicated.
 - 6. Curved Partitions:
 - a. Bend track to uniform curve and locate straight lengths so they are tangent to arcs.
 - b. Begin and end each arc with a stud, and space intermediate studs equally along arcs. On straight lengths of no fewer than two studs at ends of arcs, place studs 6 inches (150 mm) o.c.
- E. Direct Furring:
 - 1. Screw to wood framing.
 - 2. Attach to concrete or masonry with stub nails, screws designed for masonry attachment, or powder-driven fasteners spaced 24 inches (610 mm) o.c.

3.5 INSTALLING SUSPENSION SYSTEMS

- A. Install suspension system components according to spacings indicated, but not greater than spacings required by referenced installation standards for assembly types.
 - 1. Hangers: 48 inches (1219 mm) o.c.
 - 2. Carrying Channels (Main Runners): 48 inches (1219 mm) o.c.

3. Furring Channels (Furring Members): 16 inches (406 mm) o.c.
- B. Isolate suspension systems from building structure where they abut or are penetrated by building structure to prevent transfer of loading imposed by structural movement.
- C. Suspend hangers from building structure as follows:
1. Install hangers plumb and free from contact with insulation or other objects within ceiling plenum that are not part of supporting structural or suspension system.
 - a. Splay hangers only where required to miss obstructions and offset resulting horizontal forces by bracing, countersplaying, or other equally effective means.
 2. Where width of ducts and other construction within ceiling plenum produces hanger spacings that interfere with locations of hangers required to support standard suspension system members, install supplemental suspension members and hangers in the form of unistrut or equivalent devices.
 3. Wire Hangers: Secure by looping and wire tying, either directly to structures or to inserts, eye screws, or other devices and fasteners that are secure and appropriate for substrate, and in a manner that will not cause hangers to deteriorate or otherwise fail.
 4. Flat Hangers: Secure to structure, including intermediate framing members, by attaching to inserts, eye screws, or other devices and fasteners that are secure and appropriate for structure and hanger, and in a manner that will not cause hangers to deteriorate or otherwise fail.
 5. Do not attach hangers to steel roof deck.
 6. Do not attach hangers to permanent metal forms. Furnish cast-in-place hanger inserts that extend through forms.
 7. Do not attach hangers to rolled-in hanger tabs of composite steel floor deck.
 8. Do not connect or suspend steel framing from ducts, pipes, or conduit.
- D. Fire-Resistance-Rated Assemblies: Wire tie furring channels to supports.
- E. Seismic Bracing: Sway-brace suspension systems with hangers used for support.
- F. Grid Suspension Systems: Attach perimeter wall track or angle where grid suspension systems meet vertical surfaces. Mechanically join main beam and cross-furring members to each other and butt-cut to fit into wall track.
- G. Installation Tolerances: Install suspension systems that are level to within 1/8 inch in 12 feet (3 mm in 3.6 m) measured lengthwise on each member that will receive finishes and transversely between parallel members that will receive finishes.

END OF SECTION



Design No. U411 BXUV.U411 Fire Resistance Ratings - ANSI/UL 263

[Page Bottom](#)

Design/System/Construction/Assembly Usage Disclaimer

- Authorities Having Jurisdiction should be consulted in all cases as to the particular requirements covering the installation and use of UL Certified products, equipment, system, devices, and materials.
- Authorities Having Jurisdiction should be consulted before construction.
- Fire resistance assemblies and products are developed by the design submitter and have been investigated by UL for compliance with applicable requirements. The published information cannot always address every construction nuance encountered in the field.
- When field issues arise, it is recommended the first contact for assistance be the technical service staff provided by the product manufacturer noted for the design. Users of fire resistance assemblies are advised to consult the general Guide Information for each product category and each group of assemblies. The Guide Information includes specifics concerning alternate materials and alternate methods of construction.
- Only products which bear UL's Mark are considered Certified.

BXUV - Fire Resistance Ratings - ANSI/UL 263

BXUV7 - Fire Resistance Ratings - CAN/ULC-S101 Certified for Canada

[See General Information for Fire-resistance Ratings - ANSI/UL 263](#)

[See General Information for Fire Resistance Ratings - CAN/ULC-S101 Certified for Canada](#)

Design No. U411

February 25, 2015

Nonbearing Wall Rating — 2 HR.

*** Indicates such products shall bear the UL or cUL Certification Mark for jurisdictions employing the UL or cUL Certification (such as Canada), respectively.**

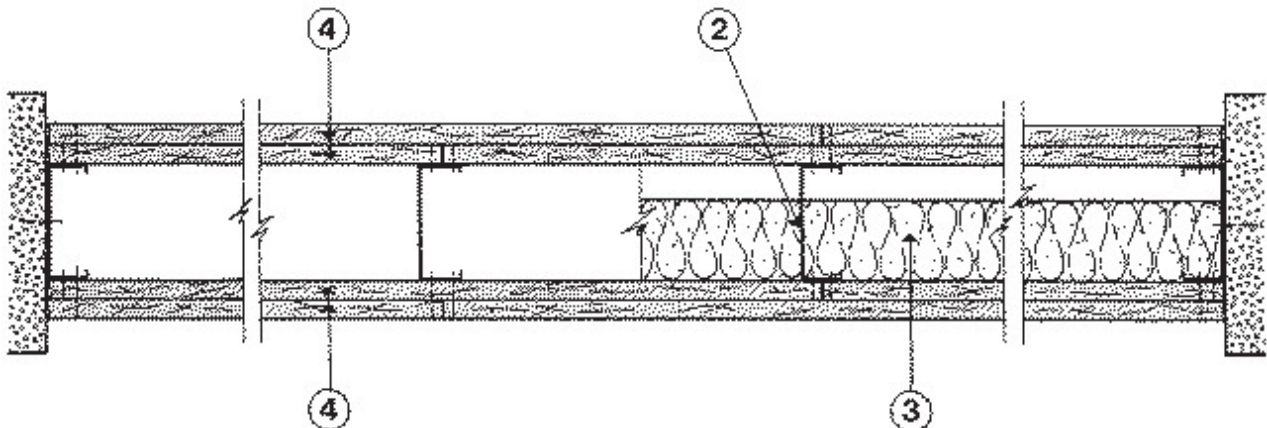

1. **Floor and Ceiling Runner** — (Not Shown) — Min. 25 MSG galv steel, 1 in. return legs, 2-1/2 in. deep (min), attached to floor and ceiling with fasteners 24 in. OC max.

1A. **Framing Members*— Floor and Ceiling Runners** — (Not shown) — As an alternate to Item 1 - For use with Item 2A, channel shaped, min 2-1/2 in. deep, attached to floor and ceiling with fasteners 24 in. OC. max.

ALLSTEEL & GYPSUM PRODUCTS INC — Type SUPREME Framing System

CALIFORNIA EXPANDED METAL PRODUCTS CO — Viper20™ Track

CONSOLIDATED FABRICATORS CORP, BUILDING PRODUCTS DIV — Type SUPREME Framing System

MARINO/WARE, DIV OF WARE INDUSTRIES INC — Viper20™ Track

PHILLIPS MFG CO L L C — Viper20™ Track

QUAIL RUN BUILDING MATERIALS INC — Type SUPREME Framing System

SCAFCO STEEL STUD MANUFACTURING CO — Type SUPREME Framing System

STEEL CONSTRUCTION SYSTEMS INC — Type SUPREME Framing System

UNITED METAL PRODUCTS INC — Type SUPREME Framing System

1B. **Floor and Ceiling Runners** — (Not shown)—For use with Item 2B- Channel shaped, fabricated from min 20 MSG corrosion-protected or galv steel, min width to accommodate stud size, with min 1 in. long legs, attached to floor and ceiling with fasteners spaced max 24 in. OC.

1C. **Framing Members*— Floor and Ceiling Runners** — (Not shown) — As an alternate to Item 1 - For use with Item 2C, channel shaped, min 2-1/2 in. wide fabricated from min 0.015 in. thick galv steel, attached to floor and ceiling with fasteners 24 in. OC. max.

CLARKDIETRICH BUILDING SYSTEMS — CD ProTRAK

DMFCWBS L L C — ProTRAK

MBA METAL FRAMING — ProTRAK

RAM SALES L L C — Ram ProTRAK

STEEL STRUCTURAL SYSTEMS L L C — Tri-S ProTRAK

1D. **Framing Members*— Floor and Ceiling Runners** — (Not shown) — As an alternate to Item 1 - For use with Item 2D, channel shaped, min 2-1/2 in. wide fabricated from min 0.018 in. thick galv steel, attached to floor and ceiling with fasteners 24 in. OC. max.

TELLING INDUSTRIES L L C — TRUE-TRACK™

1E. **Framing Members*— Floor and Ceiling Runners** — (Not shown) — As an alternate to Item 1 - For use with Item 2E, channel shaped, min 2-1/2 in. wide fabricated from min 25 MSG steel, attached to floor and ceiling with fasteners 24 in. OC. max.

KIRII (HONG KONG) LTD — Type KIRII

1F. **Floor and Ceiling Runners** — (Not shown) — Channel shaped, fabricated from min 0.02 in. galv steel, min width to accommodate stud size, with min 1 in. long legs, for use with studs specified below and fabricated from min 0.02 in. galv steel or thicker, attached to floor and ceiling with fasteners spaced max 24 in. OC.

MARINO/WARE, DIV OF WARE INDUSTRIES INC — Viper20™ Track VT100.

1G. **Framing Members*— Floor and Ceiling Runners** — (Not shown) — As an alternate to Item 1 - For use with Item 2G, channel shaped, min 2-1/2 in. deep, attached to floor and ceiling with fasteners 24 in. OC. max.

TELLING INDUSTRIES L L C — Viper20™ Track

2. **Steel Studs** — Min 2-1/2 in. deep, formed of min 25 MSG galv steel max stud spacing 24 in. OC. Studs to be cut 3/4 in. less than assembly height.

2A. **Framing Members*— Steel Studs** — As an alternate to Item 2 - For use with Item 1G, channel shaped studs, min 2-1/2 in. deep, spaced a max of 24 in. OC. Studs to be cut 3/4 in. less than assembly height.

ALLSTEEL & GYPSUM PRODUCTS INC — Type SUPREME Framing System

CALIFORNIA EXPANDED METAL PRODUCTS CO — Viper20™

CONSOLIDATED FABRICATORS CORP, BUILDING PRODUCTS DIV — Type SUPREME Framing System

MARINO/WARE, DIV OF WARE INDUSTRIES INC — Viper20™

PHILLIPS MFG CO L L C — Viper20™

QUAIL RUN BUILDING MATERIALS INC — Type SUPREME Framing System

SCAFCO STEEL STUD MANUFACTURING CO — Type SUPREME Framing System

STEEL CONSTRUCTION SYSTEMS INC — Type SUPREME Framing System

UNITED METAL PRODUCTS INC — Type SUPREME Framing System

2B. **Steel Studs** — (As an alternate to Item 2, For use with Item 4D) Channel shaped, fabricated from min 20 MSG corrosion-protected or galv steel, 3-1/2 in. min depth, spaced a max of 16 in. OC. Studs friction-fit into floor and ceiling runners. Studs to be cut 5/8 to 3/4 in. less than assembly height.

2C. **Framing Members*— Steel Studs** — As an alternate to Item 2 - For use with Item 1C, channel shaped studs, min 2-1/2 in. wide fabricated from min 0.015 in. thick galv steel, spaced a max of 24 in. OC. Studs to be cut 3/4 in. less than assembly height.

CLARKDIETRICH BUILDING SYSTEMS — CD ProSTUD

DMFCWBS L L C — ProSTUD

MBA METAL FRAMING — ProSTUD

RAM SALES L L C — Ram ProSTUD

STEEL STRUCTURAL SYSTEMS L L C — Tri-S ProSTUD

2D. **Framing Members*— Steel Studs** — As an alternate to Item 2 - For use with Item 1D, channel shaped studs, min 2-1/2 in. wide fabricated from min 0.018 in. thick galv steel, spaced a max of 24 in. OC. Studs to be cut 3/4 in. less than assembly height.

TELLING INDUSTRIES L L C — TRUE-STUD™

2E. **Framing Members*— Steel Studs** — As an alternate to Item 2 - For use with Item 1E, channel shaped studs, min 2-1/2 in. wide fabricated from min 25 MSG steel, spaced a max of 24 in. OC. Studs to be cut 3/4 in. less than assembly height.

KIRII (HONG KONG) LTD — Type KIRII

2F. **Framing Members*— Steel Studs** — As an alternate to Item 2 - For use with Item 1G, channel shaped studs, min 2-1/2 in. deep, spaced a max of 24 in. OC. Studs to be cut 3/4 in. less than assembly height.

TELLING INDUSTRIES L L C — Viper20™

2G. **Framing Members*— Steel Studs** — As an alternate to Item 2 - For use with Item 1, channel shaped studs, Min 2-1/2 in. deep, formed of min 25 MSG galv steel max stud spacing 24 in. OC. Studs to be cut 3/4 in. less than assembly height.

EB MÉTAL INC — EB Stud

2H. **Framing Members*— Steel Studs** — As an alternate to Item 2 - For use with Item 1, channel shaped studs, Min 2-1/2 in. deep, formed of min 25 MSG galv steel max stud spacing 24 in. OC. Studs to be cut 3/4 in. less than assembly height.

OLMAR SUPPLY INC — PRIMESTUD

3. **Batts and Blankets*** — (Optional) — Mineral wool or glass fiber batts partially or completely filling stud cavity.

See **Batts and Blankets** (BZJZ) category for names of manufacturers.

3A. **Fiber, Sprayed*** — As an alternate to Batts and Blankets (Item 3) — (100% Borate Formulation) — Spray applied cellulose material. The fiber is applied with water to completely fill the enclosed cavity in accordance with the application instructions supplied with the product with a nominal dry density of 2.7 lb/ft³. Alternate Application Method: The fiber is applied without water or adhesive at a nominal dry density of 3.5 lb/ft³, in accordance with the application instructions supplied with the product.

U S GREENFIBER L L C — INS735 & INS745 for use with wet or dry application. INS765LD and INS770LD are to be used for dry application only.

3B. **Fiber, Sprayed*** — As an alternate to Batts and Blankets (Item 3) and Item 3A - Spray applied cellulose insulation material. The fiber is applied with water to interior surfaces in accordance with the application instructions supplied with the product. Applied to completely fill the enclosed cavity. Minimum dry density of 4.3 pounds per cubic ft.

NU-WOOL CO INC — Cellulose Insulation

3C. **Fiber, Sprayed*** — As an alternate to Batts and Blankets (Item 3) - Spray applied cellulose fiber. The fiber is applied with water to completely fill the enclosed cavity in accordance with the application instructions supplied with the product. The minimum dry density shall be 4.30 lbs/ft³.

INTERNATIONAL CELLULOSE CORP — Celbar-RL

4. **Gypsum Board*** — 5/8 in. thick, outer layer paper, glass mat or vinyl surfaced. (Laminated System) Gypsum board applied vertically in two layers. Inner layer attached to studs with 1 in. long Type S steel screws spaced 8 in. OC along vertical edges, and 12 in. OC in the field and outer layer laminated to inner layer with joint compound, applied with a notched spreader producing continuous beads of compound about 3/8 in. in diameter, spaced not greater than 2 in. OC. Joints of laminated outer layer offset 12 in. from inner layer joints Outer layer gypsum board attached to floor and ceiling runner track with 1-5/8 in. long Type S steel screws spaced 12 in. OC.

Optional, (Direct Attached System), Inner layer attached to studs with 1 in. long Type S steel screws spaced 16 in. OC in the field and along the vertical edges. Outer layer attached to the studs over the inner layer with 1-5/8 in. long Type S steel screws spaced 16 in. OC in the field and along the vertical edges and 12 in. OC to the floor and ceiling runners. Joints of screw-attached outer layer offset from inner layer joints. Joints of outer layer may be taped or untaped.

Nom 3/32 in. thick gypsum veneer plaster may be applied to the entire surface of Classified veneer baseboard. Joints reinforced.

ACADIA DRYWALL SUPPLIES LTD — Type X, 5/8 Type X, Type Blueglass Exterior Sheathing

AMERICAN GYPSUM CO — Types AG-C, AGX-1, M-Glass, AGX-11.

BEIJING NEW BUILDING MATERIALS PUBLIC LTD CO — Type DBX-1.

CERTAINTED GYPSUM INC — Types 1, FRPC, EGRG, GlasRoc, Type X or Type C, 5/8" Easi-Lite Type X.

CGC INC — Type AR, C, IP-AR, IP-X1, IP-X2, IPC-AR, SCX, SHX, WRC or WRX.

CONTINENTAL BUILDING PRODUCTS OPERATING CO, L L C — Types LGFC2A, LGFC6A, LGFC-C/A, LGFC-WD, LGLLX.

GEORGIA-PACIFIC GYPSUM L L C — Types 5, 6, 9, C, DAP, DD, DA, DAPC, DGG, DS, GPFS6, LS, TG-C, Type X, Veneer Plaster Base-Type X, Water Rated-Type X, Sheathing Type-X, Soffit-Type X, GreenGlass Type X, Type X ComfortGuard Sound Deadening Gypsum Board, Type LWX, Veneer Plaster Base-Type LWX, Water Rated-Type LWX, Sheathing Type-LWX, Soffit-Type LWX, Type DGLW, Water Rated-Type DGLW, Sheathing Type- DGLW, Soffit-Type DGLW, Type LW2X, Veneer Plaster Base - Type LW2X, Water Rated - Type LW2X, Sheathing - Type LW2X, Soffit - Type LW2X, Type DGL2W, Water Rated - Type DGL2W, Sheathing - Type DGL2W.

NATIONAL GYPSUM CO — Types eXP-C, FSK, FSK-C, FSW, FSW-3, FSW-5, FSW-6, FSW-8, FSW-C, FSW-G, FSMR-C, FSL, SoundBreak XP Type X Gypsum Board.

PABCO BUILDING PRODUCTS L L C, DBA PABCO GYPSUM — Type C, PG-3, PG-5, PG-9, PG-11, PG-C, PGS-WRS.

PANEL REY S A — Types GREX, PRX, RHX, MDX, ETX or PRC.

SIAM GYPSUM INDUSTRY (SARABURI) CO LTD — Type EX-1

THAI GYPSUM PRODUCTS PCL — Type C or Type X

UNITED STATES GYPSUM CO — Type AR, C, FRX-G, IP-AR, IP-X1, IP-X2, IPC-AR, SCX, SGX, SHX, WRC, WRX, USGX.

USG MEXICO S A DE C V — Type AR, C, IP-AR, IP-X1, IP-X2, IPC-AR, SCX, SHX, WRC or WRX.

4A. **Gypsum Board*** — (As an alternate to Item 4) — Nom 3/4 in. thick, installed as described in Item 4 with 1-1/4 in. long Type S screws for inner layer and 2-1/4 in. long Type S screws for outer layer.

CGC INC — Types AR, IP-AR.

UNITED STATES GYPSUM CO — Types AR, IP-AR.

USG MEXICO S A DE C V — Types AR, IP-AR.

4B. **Gypsum Board*** — (As an alternate to Item 4 and 4A) — 5/8 in. thick, 24 to 54 in. wide, applied horizontally as the outer layer to one side of the assembly. Horizontal joints need not be backed by steel framing. Secured as described in Item 4 for the direct attached system. When used in widths other than 48 in., gypsum panels to be installed horizontally.

CERTAINEED GYPSUM INC — Type X, Type C.

CGC INC — Type SHX.

THAI GYPSUM PRODUCTS PCL — Type X, Type C.

UNITED STATES GYPSUM CO — Type SHX, FRX-G.

USG MEXICO S A DE C V — Type SHX.

4C. **Gypsum Board*** — (As an alternate to Items 4, 4A and 4B) — Two layers of 5/8 in. thick gypsum board applied horizontally or vertically. Inner layer attached to studs with No. 6 by 1 in. long Type S bugle head screws spaced 24 in. OC along the top and bottom tracks starting 2 in. and then 12 in. from the vertical edge. Inner layer screws spaced 24 in. OC along the studs, starting 2 in. and then 12 in. from the top and bottom of the studs and starting 1-1/4 in. from the horizontal joints when installed horizontally. Outer layer attached to studs with 1-5/8 in. long Type S bugle head screws spaced 16 in. OC along the top and bottom tracks starting 1-3/4 in. from the vertical edge. Outer layer screws spaced 16 in. OC along the studs, starting 1-3/4 in. and then 8 in. from the top and bottom of the studs and starting 1-

1/4 in. and then 8 in. from the horizontal joints when installed horizontally. Vertical joints centered over studs and staggered one stud cavity on opposite sides of studs. Vertical joints in adjacent layers staggered one stud cavity. Horizontal joints need not be backed by steel framing. Horizontal edge joints and horizontal butt joints on opposite sides of studs need not be staggered. Horizontal edge joints and horizontal butt joints in adjacent layers staggered a min of 12 in. When outer layers are installed horizontally, vinyl or casein, dry or premixed joint compound shall be applied in two coats to joints and screw heads of outer layer. Paper tape, nom 2 in. wide, embedded in first layer of compound over all joints of outer layer panels. Nom 3/32 in. thick gypsum veneer plaster may be applied to the entire surface of Classified veneer baseboard. Joints reinforced.

GEORGIA-PACIFIC GYPSUM L L C — Types 5, 6, 9, C, DAP, DD, DA, DAPC, DGG, DS, GPFS6, LS, TG-C, Type X, Veneer Plaster Base-Type X, Water Rated-Type X, Sheathing Type-X, Soffit-Type X, GreenGlass Type X, Type X ComfortGuard Sound Deadening Gypsum Board, Type LWX, Veneer Plaster Base-Type LWX, Water Rated-Type LWX, Sheathing Type-LWX, Soffit-Type LWX, Type DGLW, Water Rated-Type DGLW, Sheathing Type- DGLW, Soffit-Type DGLW, Type LW2X, Veneer Plaster Base - Type LW2X, Water Rated - Type LW2X, Sheathing - Type LW2X, Soffit - Type LW2X, Type DGL2W, Water Rated - Type DGL2W, Sheathing - Type DGL2W.

4D. **Gypsum Board*** — (Not Shown) - (As an alternate to Item 4 when used as the base layer on one or both sides of wall. For direct attachment only to steel studs Item 2B) - Nom 5/8 in. thick lead backed gypsum panels with beveled, square or tapered edges, applied vertically. Vertical joints centered over studs and staggered min 1 stud cavity on opposite sides of studs. Gypsum board secured to studs with 1-1/4 in. long Type S-12 steel screws spaced 8 in. OC at perimeter and 12 in. OC in the field.

RAY-BAR ENGINEERING CORP — Type RB-LBG

4E. **Gypsum Board*** — (As an alternate to Items 4 through 4D) — Nominal 5/8 in. thick, 4 ft wide panels, applied vertically and secured as described in Item 4.

PABCO BUILDING PRODUCTS L L C, DBA PABCO GYPSUM — Types QuietRock ES.

4F. **Gypsum Board*** — (As an alternate to Items 4 through 4E) - 5/8 in. thick, 4 ft. wide, paper surfaced, applied vertically and secured as described in Item 4.

CERTAINTED GYPSUM INC — Type SilentFX

4G. **Gypsum Board*** — As an alternate to Item 4- Nom. 5/8 in. thick, inner layer attached vertically to studs with 1 in. long Type S steel screws spaced 16 in. OC in the field and along the vertical edges. Outer layer attached to the studs horizontally over the inner layer with 1-5/8 in. long Type S steel screws spaced 16 in. OC in the field and along the vertical edges and 12 in. OC to the floor and ceiling runners. Joints of outer layer must be taped. Nom 3/32 in. thick gypsum veneer plaster may be applied to the entire surface of Classified veneer baseboard.

ACADIA DRYWALL SUPPLIES LTD — Type Blueglass Exterior Sheathing

PABCO BUILDING PRODUCTS L L C, DBA PABCO GYPSUM — Types C, PG-11, PGS-WRS.

4H. **Gypsum Board*** — (Not Shown) - (As an alternate to Items 4) For Direct Application to Studs Only- For use as the base layer on one or both sides of the wall. Nom 5/8 in. thick lead backed gypsum panels with beveled, square or tapered edges, applied vertically. Vertical joints centered over studs and staggered min 1 stud cavity on opposite sides of studs. Wallboard secured to studs with 1-5/8 in. long Type S 12 steel screws spaced 8 in. OC at perimeter and 12 in OC in the field. Lead batten strips required behind vertical joints of lead backed gypsum wallboard and optional at remaining stud locations. Fasteners for face layer gypsum panels when installed over lead backed board to be min 2-1/2 in. Type S-12 bugle head steel screws spaced as described in Item 4. To be used with Lead Batten Strips (see Item 5A) or Lead Discs (see Item 6A).

MAYCO INDUSTRIES INC — Type X-Ray Shielded Gypsum

4I. **Gypsum Board*** — (As an alternate to Item 4, not for use with Items 1C and 2C) - Nom. 5/8 in. thick gypsum panels with beveled, square or tapered edges installed as described in Item 4.

CGC INC — Type ULX

UNITED STATES GYPSUM CO — Type ULX.

USG MEXICO S A DE C V — Type ULX

4J. **Gypsum Board*** — (As an alternate to Item 4 when used as the base layer on one or both sides of wall. For direct attachment only to steel studs Item 2B). Nom 5/8 in. thick lead backed gypsum panels with beveled, square or tapered edges, applied vertically. Vertical joints centered over studs and staggered min 1 stud cavity on opposite sides of studs.

Wallboard secured to studs with 1-1/4 in. long Type S-12 steel screws gypsum panel steel screws spaced 8 in. OC at perimeter and 12 in. OC in the field. Lead batten strips required behind vertical joints of lead backed gypsum wallboard and optional at remaining stud locations. Lead batten strips, min 2 in. wide, max 8 ft long with a max thickness of 0.14 in. placed on the face of studs and attached to the stud with construction adhesive and two 1 in. long Type S-12 pan head steel screws, one at the top of the strip and one at the bottom of the strip. Lead discs, nominal 3/8 in. diam by max 0.085 in. thick. Compression fitted or adhered over the screw heads. Lead batten strips and discs to have a purity of 99.9% meeting the Federal specification QQ-L-201f, Grade "C".

RADIATION PROTECTION PRODUCTS INC — Type RPP - Lead Lined Drywall

4K. **Gypsum Board** — (As an alternate to Items 4 through 4J, not for use with Items 1C and 2C). Two layers of nominal 15 mm thick gypsum board applied vertically. Inner layer attached to studs with No. 3.5 x 1-3/8 in. long bugle head, self-drilling screws spaced 23-5/8 in. OC in the field and 15-3/4 in. OC in the perimeter, with the first screw 2 in. from the edge. Outer layer attached to the studs over the inner layer with No. 3.5 x 1-3/4 in. long bugle head, self-drilling screws spaced 11-13/16 in. OC in the field and 7-7/8 in. OC in the perimeter, with the first screw 3/4 in. from the edge. Outer layer screws staggered from inner layer screws. Vertical joints centered over studs and staggered one stud cavity on opposite sides of studs. Vertical joints in adjacent layer staggered one stud cavity. Self-adhesive fiberglass mesh (9x9 mesh) tape, nom 2 in. wide, applied over all joints of outer layer panels. Dry or premixed joint compound applied in two coats to joints over the mesh tape and screw heads of outer layer.

GYPSEMNA CO LLC — Types MRFW, FW, TF.

4L. **Gypsum Board*** — (As an alternate to Items 4 through 4K) - Two layers of 5/8 in. thick gypsum board applied vertically or horizontally. Inner layer attached to studs with #6 x 1 in. long bugle head screws spaced 12 in. OC along the top and bottom tracks and 16 in. OC in the field and along the vertical edges. Outer layer attached to studs with #6 x 1-5/8 in. long bugle head screws spaced 12 in. OC along the top and bottom tracks and 16 in. OC in the field and along the vertical edges. Vertical joints are centered over studs and staggered between layers and on opposite sides of the wall. Horizontal joints on the face layer are staggered 12 in. from the base layer. Horizontal joints need not to be backed by steel framing.

CONTINENTAL BUILDING PRODUCTS OPERATING CO, L L C — Type LGFC6A, LGFC-C/A.

4M. **Wall and Partition Facings and Accessories*** — (As an alternate to Items 4 through 4L) — Nominal 5/8 in. thick, 4 ft wide panels, applied vertically and secured as described in Item 4.

PABCO BUILDING PRODUCTS L L C, DBA PABCO GYPSUM — Type QuietRock 527.

4N. **Gypsum Board*** — (As an alternate to Item 4 through 4M) - For direct application to studs only - Four layers nom. 5/16 in. thick gypsum panels applied vertically or horizontally. When applied horizontally, base layer secured to studs with 1 in. Type S screws spaced 24 in. OC. Second layer installed with joints offset 12 in. from base layer and secured with 1 in. Type S screws spaced 24 in. OC. Third layer installed with joints in line with base layer and secured with 1-1/2 in. Type S screws spaced 16 in. OC. Fourth layer installed with joints in line with second layer and secured with 1-5/8 in. Type S screws spaced 12 in. OC. For all layers, screws offset 4 in. from previous layer. When applied vertically, base layer secured with 1 in. Type S screws spaced 24 in. OC. Second layer secured with joints offset one stud cavity and secured with 1 in. Type S screws spaced 24 in. OC. Third layer installed with joints in line with base layer and secured with 1-1/2 in. Type S screws spaced 12 in. OC. Fourth layer secured with joints in line with second layer and secured with 1-5/8 in. Type S screws spaced 8 in. OC along vertical edges and 12 in. OC in the field. For all layers, screws offset 4 in. from previous layer.

NATIONAL GYPSUM CO — Type FSW

5. **Lead Batten Strips** — (Not Shown, For Use With Item 4D) - Lead batten strips, min 1-1/2 in. wide, max 10 ft long with a max thickness of 0.125 in. Strips placed on the interior face of studs and attached from the exterior face of the stud with two 1 in. long Type S-12 pan head steel screws, one at the top of the strip and one at the bottom of the strip. Lead batten strips to have a purity of 99.9% meeting the Federal specification QQ-L-201f, Grade "C". Lead batten strips required behind vertical joints of lead backed gypsum board (Item 4D) and optional at remaining stud locations. Required behind vertical joints.

5A. **Lead Batten Strips** — (Not Shown, for use with Item 4H) Lead batten strips, 2 in. wide, max 10 ft long with a max thickness of 0.140 in. Strips placed on the face of studs and attached to the stud with two min. 1 in. long min. Type S-8 pan head steel screws, one at the top of the strip and one at the bottom of the strip or with one min. 1 in. long min. Type S-8 pan head steel screw at the top of the strip. Lead batten strips to have a purity of 99.5% meeting the Federal specification QQ-L-201f, Grades "B, C or D". Lead batten strips required behind vertical joints of lead backed gypsum wallboard (Item 6) and optional at remaining stud locations.

6. **Lead Discs or Tabs** — (Not Shown, For Use With Item 4D) - Used in lieu of or in addition to the lead batten strips (Item 5) or optional at other locations - Max 3/4 in. diam by max 0.125 in. thick lead discs compression fitted or adhered over steel screw heads or max 1/2 in. by 1-1/4 in. thick lead tabs placed on gypsum boards (Item 4D) underneath screw locations prior to the installation of the screws. Lead discs or tabs to have a purity of 99.9% meeting the Federal specification QQ-L-201f, Grade "C".

6A. **Lead Discs** — (Not Shown, for use with Item 4H) Max 5/16 in. diam by max 0.140 in. thick lead discs compression fitted or adhered over steel screw heads. Lead discs to have a purity of 99.5% meeting the Federal Specification QQ-L-201f, Grades "B, C or D".

7. Mineral and Fiber Board* — (Optional, Not shown) — For optional use as an additional layer on one side of wall. Nom 1/2 in. thick, 4 ft wide with long dimension parallel and centered over studs. Attached to studs and floor and ceiling runners with 1-5/8 in. long Type S steel screws, spaced 12 in. OC. The required UL Classified gypsum board layer(s) is/are to be installed as indicated as to fastener type and spacing, except that the required fastener length shall be increased by a minimum of 1/2 in. Not evaluated or intended as a substitute for the required layer(s) of UL Classified Gypsum Board.

HOMASOTE CO — Homasote Type 440-32

*** Indicates such products shall bear the UL or cUL Certification Mark for jurisdictions employing the UL or cUL Certification (such as Canada), respectively.**

Last Updated on 2015-02-25

[Questions?](#)

[Print this page](#)

[Terms of Use](#)

[Page Top](#)

© 2015 UL LLC

When the UL Leaf Mark is on the product, or when the word "Environment" is included in the UL Mark, please search the [UL Environment database](#) for additional information regarding this product's certification.

The appearance of a company's name or product in this database does not in itself assure that products so identified have been manufactured under UL's Follow-Up Service. Only those products bearing the UL Mark should be considered to be Certified and covered under UL's Follow-Up Service. Always look for the Mark on the product.

UL permits the reproduction of the material contained in the Online Certification Directory subject to the following conditions: 1. The Guide Information, Assemblies, Constructions, Designs, Systems, and/or Certifications (files) must be presented in their entirety and in a non-misleading manner, without any manipulation of the data (or drawings). 2. The statement "Reprinted from the Online Certifications Directory with permission from UL" must appear adjacent to the extracted material. In addition, the reprinted material must include a copyright notice in the following format: "© 2015 UL LLC".



Design No. U415 BXUV.U415 Fire Resistance Ratings - ANSI/UL 263

[Page Bottom](#)

Design/System/Construction/Assembly Usage Disclaimer

- Authorities Having Jurisdiction should be consulted in all cases as to the particular requirements covering the installation and use of UL Certified products, equipment, system, devices, and materials.
- Authorities Having Jurisdiction should be consulted before construction.
- Fire resistance assemblies and products are developed by the design submitter and have been investigated by UL for compliance with applicable requirements. The published information cannot always address every construction nuance encountered in the field.
- When field issues arise, it is recommended the first contact for assistance be the technical service staff provided by the product manufacturer noted for the design. Users of fire resistance assemblies are advised to consult the general Guide Information for each product category and each group of assemblies. The Guide Information includes specifics concerning alternate materials and alternate methods of construction.
- Only products which bear UL's Mark are considered Certified.

BXUV - Fire Resistance Ratings - ANSI/UL 263

BXUV7 - Fire Resistance Ratings - CAN/ULC-S101 Certified for Canada

[See General Information for Fire-resistance Ratings - ANSI/UL 263](#)

[See General Information for Fire Resistance Ratings - CAN/ULC-S101 Certified for Canada](#)

Design No. U415

March 16, 2015

Nonbearing Wall Ratings – 1, 2, 3 or 4 Hr

* Indicates such products shall bear the UL or cUL Certification Mark for jurisdictions employing the UL or cUL Certification (such as Canada), respectively.

System A – 1 Hr.

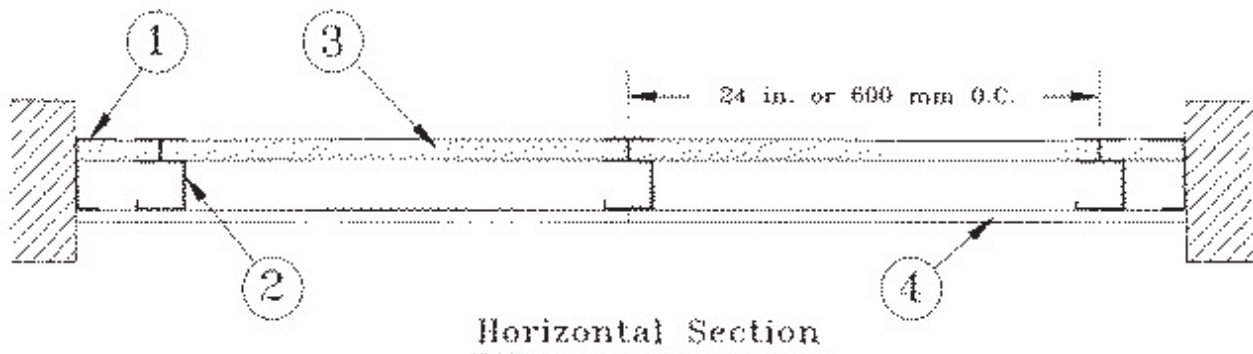

System B - 2 Hr.

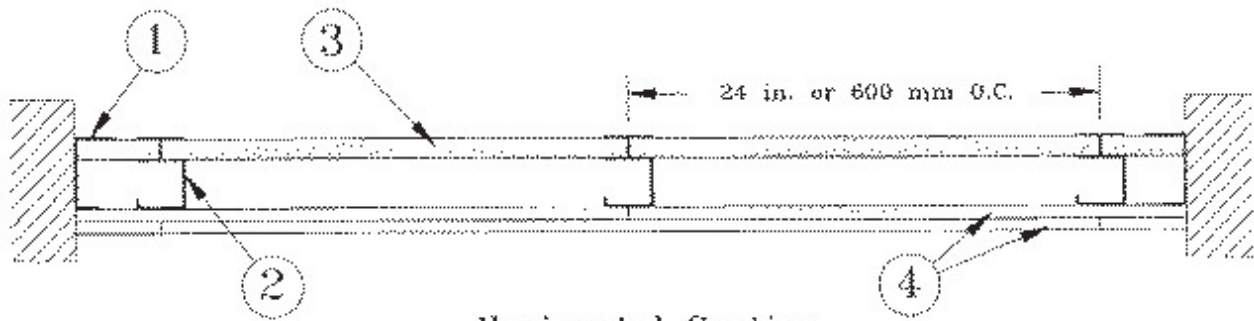

Horizontal Section

System C - 2 Hr.

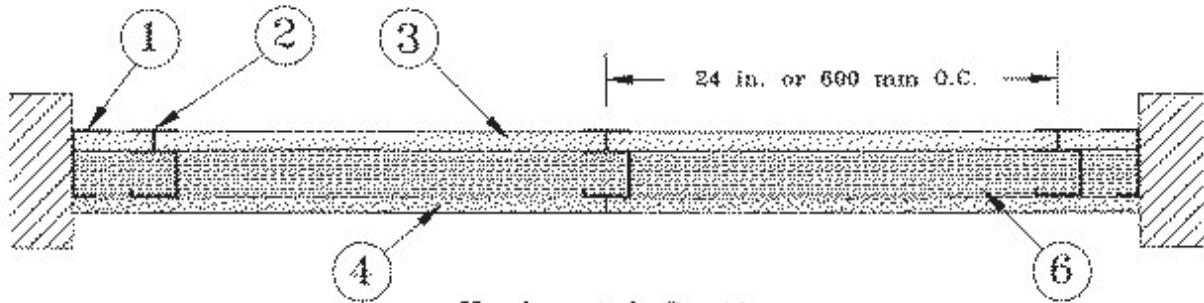

Horizontal Section

System D - 2 Hr.

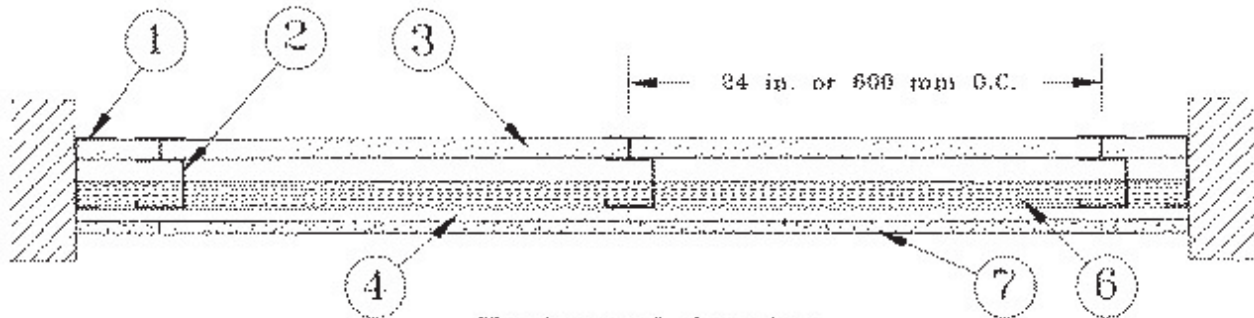

Horizontal Section

System E - 2 Hr.

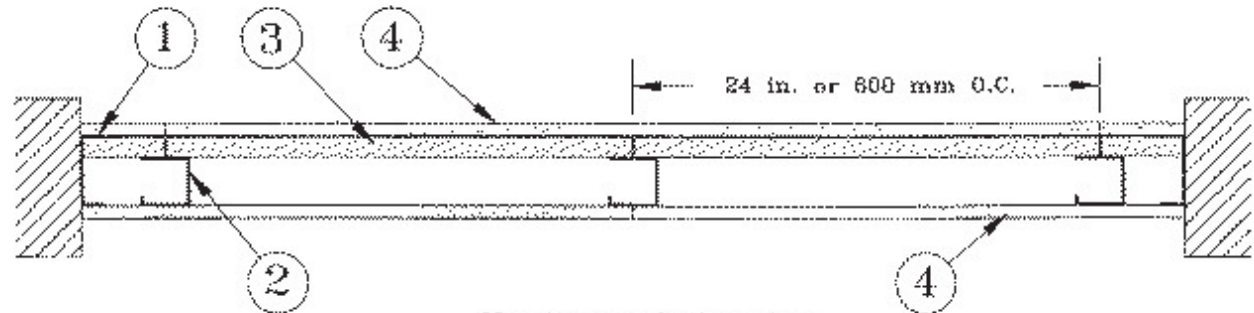

Horizontal Section

System F - 2 Hr.

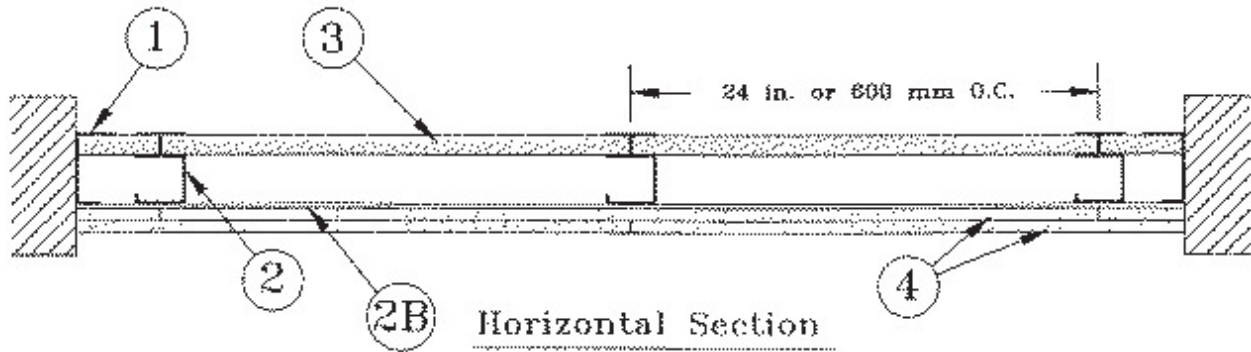

System G - 3 Hr.

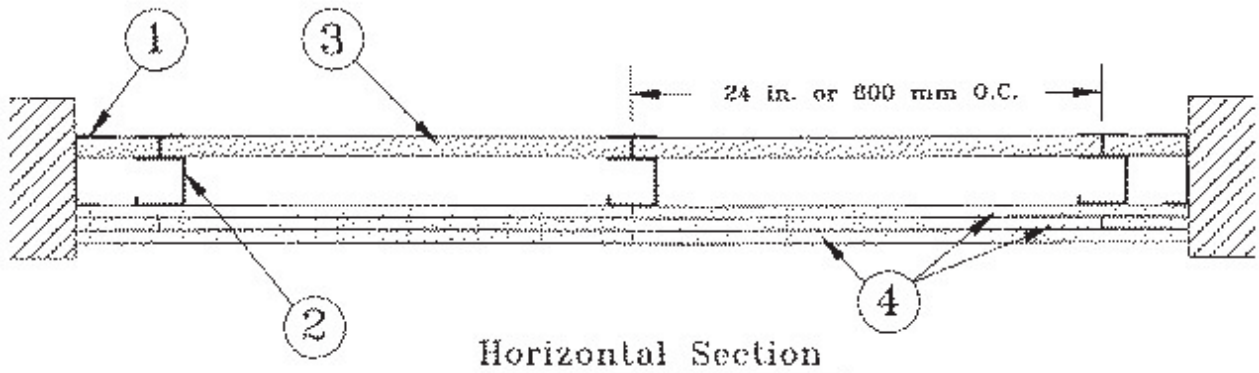

System H - 3 Hr.

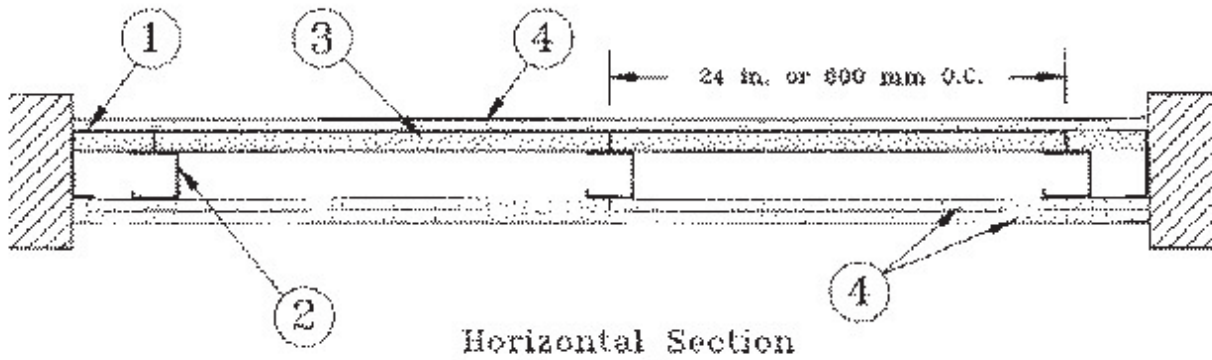

System I - 4 Hr.

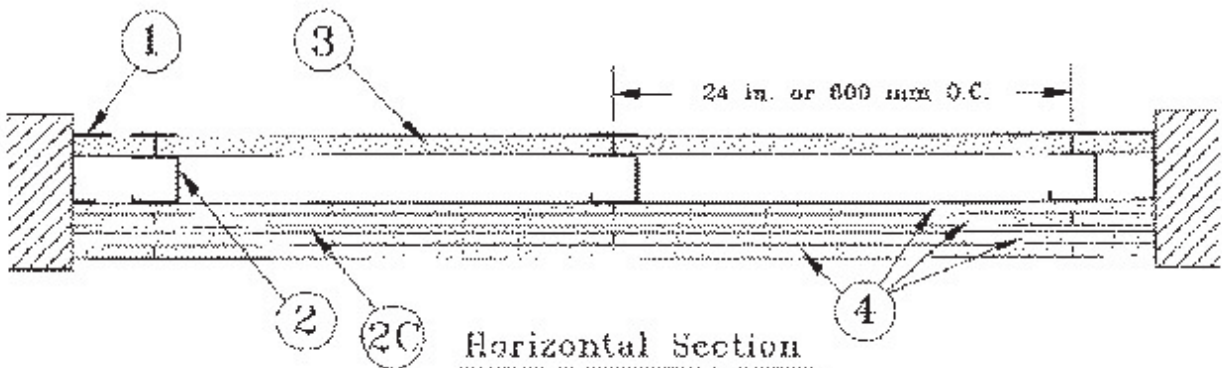

1. **Floor, Side and Ceiling Runners** - "J" - shaped runner, min 2-1/2 in. deep (min 4 in. deep when System C is used), with unequal legs of 1 in. and 2 in., fabricated from min 24 MSG (min 20 MSG when Item 4A, 4B or 7 are used) galv steel. Runners positioned with short leg toward finished side of wall. Runners attached to structural supports with

steel fasteners located not greater than 2 in. from ends and not greater than 24 in. OC. "E" - shaped studs (Item 2A) may be used as side runners in place of "J" - shaped runners.

2. **Steel Studs** — "C-H" - shaped studs, min 2-1/2 in. deep (min 4 in. deep when System C is used), fabricated from min 25 MSG (min 20 MSG when Items 2D, 4A, 4B or 7 is used) galv steel. Cut to lengths 3/8 to 1/2 in. less than floor-to-ceiling height and spaced 24 in. or 600 mm OC.

2A. **Steel Studs** — (Not Shown) — "E" - shaped studs installed back to back in place of "C-H" - shaped studs (Item 2) "E" - shaped studs secured together with steel screws spaced a maximum 12 in. OC. Fabricated from min 25 MSG (min 20 MSG when Item 2D, 4A, 4B or 7 is used) galv steel, min 2-1/2 in. deep (min 4 in. deep when System C is used), with one leg 1 in. long and two legs 3/4 in. long. Shorter legs 1 in. apart to engage gypsum liner panels. Cut to lengths 3/8 to 1/2 in. less than floor to ceiling heights.

2B. **Furring Channels** — (Optional, not shown) — For use with single or double layer systems. Resilient furring channels fabricated from min 25MSG corrosion protected steel, installed horizontally, and spaced vertically a max 24 in. OC. Flange portion of channel attached to each intersecting "C-H" or "E" stud on side of stud opposite the 1 in. liner panels with 1/2 in. long Type S or S-12 pan-head steel screws. When furring channels are used, wallboard to be installed vertically only. Not to be used with Type FRX-G gypsum wallboard, Type RB-LBG (Item 4A), Type Nelco (Item 4B) or cementitious backer units (Item 7).

2C. **Furring Channels** — For use with System I - "Hat" - shaped, 25 MSG galv steel furring channels attached directly over the inner layers of wallboard to each stud with 2 in. long Type S pan head steel screws. Screws alternate from top flange to bottom flange at each stud intersection. Furring channels spaced vertically max 24 in. OC.

2D. **Steel Framing Members*** — (Optional, not shown) — For use with single or double layer systems. Furring channels and Steel Framing Members as described below. Not to be used with Type FRX-G gypsum wallboard, Type RB-LBG (Item 4A), Type Nelco (Item 4B) or cementitious backer units (Item 7):

a. **Furring Channels** — Formed of No. 25 MSG galv steel. 2-9/16 in. or 2-23/32 in. wide by 7/8 in. deep, spaced max. 24 in. OC perpendicular to studs. Channels secured to studs as described in Item b. Gypsum board installed vertically only and attached to furring channels as described in Item 3.

b. **Steel Framing Members*** — Used to attach furring channels (Item 2Da) to studs (Item 2 or 2A). Clips spaced max. 24 in. OC., and secured to studs with No. 8 x 1-1/2 in. minimum self-drilling, S-12 steel screw through the center grommet. Furring channels are friction fitted into clips. RSIC-1 clip for use with 2-9/16 in. wide furring channels. RSIC-1 (2.75) clip for use with 2-23/32 in. wide furring channels.

PAC INTERNATIONAL INC — Types RSIC-1, RSIC-1 (2.75)

2E. **Steel Framing Members** — (Optional, Not Shown)* - Furring channels and resilient sound isolation clip as described below:

a. **Furring Channels** — Formed of No. 25 MSG galv steel. Spaced 24 in. OC perpendicular to studs. Channels secured to studs as described in Item b. Ends of adjoining channels overlapped 6 in. and secured together with four self-tapping No. 8x1/2 Self Drilling screws (2 per side 1 in. and 4 in. from overlap edge). Gypsum board attached to furring channels as described in Item 3. Side joint furring channels shall be attached to studs with RESILMOUNT Sound Isolation Clips - Type A237R located approximately 2 in. from each end of length of channel. Both Gypsum Boards at side joints fastened into channel with screws spaced 8 in. OC, approximately 1/2 in. from joint edge.

b. **Steel Framing Members*** — Resilient sound isolation clip used to attach furring channels (Item 2Ea) to studs. Clips spaced 24 in. OC., and secured to studs with No. 10 x 2-1/2 in. coarse drywall screw through the center hole. Furring channels are friction fitted into clips.

STUDCO BUILDING SYSTEMS — RESILMOUNT Sound Isolation Clips - Type A237R

2F. **Steel Framing Members*** — (Optional, not shown) — For use with single or double layer systems. Furring channels and Steel Framing Members as described below. Not to be used with Type FRX-G gypsum wallboard, Type RB-LBG (Item 4A), Type Nelco (Item 4B) or cementitious backer units (Item 7):

a. **Furring Channels** — Formed of No. 25 MSG galv steel. 2-3/8 in. wide by 7/8 in. deep, spaced max. 24 in. OC perpendicular to studs. Channels secured to studs as described in Item b. Gypsum board installed vertically only and attached to furring channels as described in Item 3.

b. **Steel Framing Members*** — Used to attach furring channels (Item 2Da) to studs (Item 2 or 2A). Clips spaced max. 24 in. OC. GENIECLIPS secured to studs with No. 8 x 1-1/2 in. minimum self-drilling, S-12 steel screw through the center grommet. Furring channels are friction fitted into clips.

PLITEQ INC — Type GENIECLIP

3. **Gypsum Board*** — Gypsum liner panels, nom 1 in. thick, 24 in. or 600 mm (for metric spacing) wide. Panels cut 1 in. less in length than floor to ceiling height. Vertical edges inserted in "H" portion of "C-H" studs or the gap between the two 3/4 in. legs of the "E" studs. Free edge of end panels attached to long leg of vertical "J" - runners with 1-5/8 in. long Type S steel screws spaced not greater than 12 in. OC. When wall height exceeds liner panel length, liner panel may be butted to extend to the full height of the wall. Horizontal joints need not be backed by steel framing. In

System I, butt joints in liner panels are staggered min 36 in. Butt joints backed with 6 in. by 22 in. strips of 3/4 in. thick gypsum wallboard (Item 4). Wallboard strips centered over butt joints and secured to liner panels with six 1-1/2 in. long Type G steel screws, three screws along the 22 in. dimension at the top and bottom of the strips.

CGC INC — Type SLX

UNITED STATES GYPSUM CO — Type SLX

USG MEXICO S A DE C V — Type SLX

4. Gypsum Board* —

System A — 1 Hr

Gypsum panels, with beveled, square or tapered edges, nom 5/8 in. thick, 48 in. or 1200 mm wide, applied vertically or horizontally, attached to studs with 1 in. long Type S steel screws spaced 12 in. when installed vertically or 8 in OC when installed horizontally. Horizontal joints need not be backed by steel framing.

CGC INC — Types AR, C, IP-AR, IP-X1, IP-X2, IPC-AR, SCX, SHX, ULX, WRC, WRX

UNITED STATES GYPSUM CO — Types AR, C, FRX-G, IP-AR, IP-X1, IP-X2, IPC-AR, SCX, SGX, SHX, ULX, WRC, WRX, USGX

USG MEXICO S A DE C V — Types AR, C, IP-AR, IP-X1, IP-X2, IPC-AR, SCX, SHX, ULX, WRC, WRX

System B — 2 Hr

Gypsum panels, with beveled, square or tapered edges, nom 1/2 in. or 5/8 in. thick, 48 in. or 1200 mm wide, applied vertically or horizontally in two layers. Inner or base layer attached to studs with 1 in. long Type S steel screws spaced 24 in. OC when installed vertically or 16 in. OC when installed horizontally. Outer or face layer attached to studs with 1-5/8 in. long Type S steel screws spaced 12 in. OC when installed vertically and staggered 12 in. from base layer screws or 8 in. OC when installed horizontally and staggered 8 in. from base layer screws. Horizontal joints between inner and outer layers staggered a min of 12 in. Horizontal joints need not be backed by steel framing. Vertical joints centered over studs and staggered 24 in.

CGC INC — 1/2 in. Type C, IP-X2, IPC-AR or WRC; 5/8 in. Types AR, C, IP-AR, IP-X1, IP-X2, IPC-AR, SCX, SHX, ULX, WRC, WRX

UNITED STATES GYPSUM CO — 1/2 in. Types C, IP-X2, IPC-AR, or WRC; 5/8 in. Types AR, C, FRX-G, IP-AR, IP-X1, IP-X2, IPC-AR, SCX, SGX, SHX, ULX, USGX, WRC, WRX

USG MEXICO S A DE C V — 1/2 in. Types C, IP-X2, IPC-AR or WRC; 5/8 in. Types AR, C, IP-AR, IP-X1, IP-X2, IPC-AR, SCX, SHX, ULX, WRC, WRX

System C — 2 Hr

Gypsum panels, with beveled, square or tapered edges, nom 3/4 in. thick, 48 in. or 1200 mm wide, applied vertically or horizontally, secured with 1-1/4 in. long Type S steel screws spaced 8 in. OC along vertical edges and 12 in. OC in the field when installed vertically or 8 in. OC along the vertical edges and in the field when installed horizontally. Horizontal joints need not be backed by steel framing. Screws along side joints offset 4 in. Requires min 4 in. deep framing per Items 1, 2 and 3. Requires min 3 in. thick mineral wool batts per Item 6.

CGC INC — Types IP-X3 or ULTRACODE

UNITED STATES GYPSUM CO — Types IP-X3 or ULTRACODE

USG MEXICO S A DE C V — Types IP-X3 or ULTRACODE

System D — 2 Hr

Gypsum panels, with beveled, square or tapered edges, nom 5/8 in. thick, 48 in. or 1200 mm wide, applied vertically

or horizontally, attached directly to studs with 1 in. long Type S steel screws spaced 24 in. when installed vertically or 16 in. OC when installed horizontally. Horizontal joints need not be backed by steel framing. Requires face layer of 1/2 or 5/8 in. thick cementitious backer units per Item 7 and min 1-1/2 in. thick mineral wool batts per Item 6.

CGC INC — Types AR, C, IP-AR, IP-X1, IP-X2, IPC-AR, SCX, SHX, ULX, WRC, WRX

UNITED STATES GYPSUM CO — Types AR, C, FRX-G, IP-AR, IP-X1, IP-X2, IPC-AR, SCX, SGX, SHX, ULX, USGX, WRC, WRX

USG MEXICO S A DE C V — Types AR, C, IP-AR, IP-X1, IP-X2, IPC-AR, SCX, SHX, ULX, WRC, WRX

System E — 2 Hr

Gypsum panels, with beveled, square or tapered edges, nom 1/2 in. or 5/8 in. thick, 48 in. or 1200 mm wide, applied vertically or horizontally, attached to studs with 1 in. long Type S steel screws spaced 12 in. OC when installed vertically or 8 in. when installed horizontally. Horizontal joints need not be backed by steel framing.

CGC INC — 1/2 in. Types C, IP-X2, IPC-AR; 5/8 in. Types AR, C, IP-AR, IP-X1, IP-X2, IPC-AR, SCX, SHX, ULX, WRC, WRX

UNITED STATES GYPSUM CO — 1/2 in. Types C, IP-X2, IPC-AR; 5/8 in. Types AR, C, FRX-G, IP-AR, IP-X1, IP-X2, IPC-AR, SCX, SGX, SHX, ULX, USGX, WRC, WRX.

USG MEXICO S A DE C V — 1/2 in. Types C, IP-X2, IPC-AR; 5/8 in. Types AR, C, IP-AR, IP-X1, IP-X2, IPC-AR, SCX, SHX, ULX, WRC, WRX

System F — 2 Hr

Gypsum panels, with beveled, square or tapered edges, nom 1/2 in. or 5/8 in. thick, 48 in. or 1200 mm wide, applied vertically in two layers. Inner or base layer attached to resilient furring channels (Item 2B) with 1 in. long Type S steel screws spaced 24 in. Outer or face layer attached to resilient furring channels (Item 2B) with 1-5/8 in. long Type S steel screws spaced 12 in. OC and staggered 12 in. from base layer screws. Joints between inner and outer layers staggered 24 in.

CGC INC — 1/2 in. Type C, IP-X2, IPC-AR or WRC; 5/8 in. Types AR, C, FRX-G, IP-AR, IP-X1, IP-X2, IPC-AR, SCX, SHX, ULX, WRC, WRX

UNITED STATES GYPSUM CO — 1/2 in. Type C, IP-X2, IPC-AR or WRC; 5/8 in. Types AR, C, FRX-G, IP-AR, IP-X1, IP-X2, IPC-AR, SCX, SGX, SHX, ULX, USGX, WRC, WRX

USG MEXICO S A DE C V — 1/2 in. Types C, IP-X2, IPC-AR or WRC; 5/8 in. Types AR, C, IP-AR, IP-X1, IP-X2, IPC-AR, SCX, SHX, ULX, WRC, WRX

System G — 3 Hr

Gypsum panels, with beveled, square or tapered edges, nom 5/8 in. thick, 48 in. or 1200 mm wide, applied vertically or horizontally in three layers. Inner or base layer attached to studs with 1 in. long Type S steel screws spaced 24 in. OC when installed vertically or 16 in OC when installed horizontally. Middle layer attached to studs with 1-5/8 in. long Type S steel screws spaced 24 in. when installed vertically or 16 in. OC when installed horizontally. Outer or face layer attached to studs with 2-1/4 in. long Type S steel screws spaced 16 in. when installed vertically or 12 in. OC when installed horizontally. Screws offset 6 in. from layer below. Horizontal joints on adjacent layers staggered a min of 12 in. Horizontal joints need not be backed by steel framing. Vertical joints centered over studs and staggered 24 in. on adjacent layers.

CGC INC — Types C, IP-X2, IPC-AR, WRC

UNITED STATES GYPSUM CO — Types C, IP-X2, IPC-AR, WRC

USG MEXICO S A DE C V — Types C, IP-X2, IPC-AR, WRC

System H — 3 Hr

Gypsum panels, with beveled, square or tapered edges, nom 5/8 in. thick, 48 in. or 1200 mm wide, applied vertically or horizontally, two layers over the flange of the "C" section of the studs, one layer over the flange of the "H" section of the studs. Inner or base layer attached to studs with 1 in. long Type S steel screws spaced 24 in. OC when installed vertically or 16 in. OC when installed horizontally. Face layer attached to studs with 1-5/8 in. long Type S steel screws spaced 16 in. when installed vertically or 12 in. OC when installed horizontally. Screws offset 6 in. from layer below. Horizontal joints on adjacent layers staggered a min of 12 in. Horizontal joints need not be backed by steel framing. Vertical joints centered over studs and staggered 24 in. on adjacent layers.

CGC INC — Types C, IP-X2, IPC-AR, WRC

UNITED STATES GYPSUM CO — Types C, IP-X2, IPC-AR, WRC

USG MEXICO S A DE C V — Types C, IP-X2, IPC-AR, WRC

System I — 4 Hr

Gypsum panels, with beveled, square or tapered edges, nom 3/4 in. thick, 4 ft wide (or 1200 mm for metric spacing) wallboard with square or tapered edges. Total of four layers to be used. First and second (inner) layers applied vertically or horizontally over the steel studs. Horizontal joints need not be backed by steel framing. When applied vertically, joints centered over studs and staggered min 24 in., otherwise all joints staggered min 12 in. First layer secured to studs with 1-1/4 in. long Type S self-drilling, self-tapping bugle-head steel screws spaced 24 in. OC. Second layer secured to studs with 2-1/4 in. long Type S self-drilling, self-tapping bugle-head steel screws spaced 12 in. OC. Third layer applied vertically over the furring channels (Item 2C) with a 1-1/4 in. long Type S self-drilling, self-tapping bugle-head steel screws spaced 12 in. OC. Fourth layer applied vertically or horizontally with 2-1/4 in. long Type S self-drilling, self-tapping bugle-head steel screws spaced 12 in. OC. When applied vertically, joints to be staggered min 24 in. from third layer, otherwise all joints staggered min 12 in.

CGC INC — Types IP-X3 or ULTRACODE

UNITED STATES GYPSUM CO — Types IP-X3 or ULTRACODE

USG MEXICO S A DE C V — Types IP-X3 or ULTRACODE

4A. Gypsum Board* — (As an alternate to Item 4 Systems A, B, C, D, E, G, H, and I when used as the base layer, For direct attachment only) - Nom 5/8 in. or 3/4 in. thick lead backed gypsum panels with beveled, square or tapered edges, applied vertically. Vertical joints centered over 20 MSG steel studs and staggered min 1 stud cavity on opposite sides of studs. See Items 1, 2, 2A, 2B and 2D. Wallboard secured to studs with 1-1/4 in. long Type S-12 steel screws spaced 8 in. OC at perimeter and 12 in. OC in the field. For Joint Compound see Item 5. To be used with Lead Batten Strips (see Item 9) or Lead Discs or Tabs (see Item 10).

RAY-BAR ENGINEERING CORP — Type RB-LBG

4B. Gypsum Board* — (As an alternate to Item 4 Systems A, B, C, D, E, G, H, and I when used as the base layer, For direct attachment only) - Nominal 5/8 in. thick lead backed gypsum panels with beveled, square or tapered edges, applied vertically. Vertical joints centered over studs and staggered min 1 stud cavity on opposite sides of studs. Wallboard secured to studs with 1-1/4 in. long Type S-12 (or #6 by 1-1/4 in. long bugle head fine driller) steel screws spaced 8 in. OC at perimeter and 12 in. OC in the field.

NEW ENGLAND LEAD BURNING CO INC, DBA NELCO — Type Nelco

4C. Gypsum Board* — (As an alternate to Item 4 Systems A, B, C, D, E, G, H, and I when used as the base layer, For direct attachment only) - Nom 5/8 or 3/4 in. thick lead backed gypsum panels with beveled, square or tapered edges, applied vertically. Vertical joints centered over 20 MSG steel studs and staggered min 1 stud cavity on opposite sides of studs. See Items 1, 2, 2A, 2B and 2D. Wallboard secured to studs with 1-1/4 in. long Type S-12 steel screws spaced 8 in. OC at perimeter and 12 in. OC in the field. For Joint Compound see Item 5. To be used with Lead Batten Strips (see Item 9A) or Lead Discs (see Item 10A). Lead batten strips required behind vertical joints of lead backed gypsum wallboard and optional at remaining stud locations. Lead batten strips, min 2 in. wide, max 10 ft long with a max thickness of 0.140 in. placed on the face of studs and attached to the stud with two 1 in. long Type S-8 pan head steel screws, one at the top of the strip and one at the bottom of the strip.

MAYCO INDUSTRIES INC — Type X-Ray Shielded Gypsum

4D. Gypsum Board* — (As an alternate to Item 4 Systems A, B, C, D, E, G, H, and I when used as the base layer, For direct attachment only). Nom 5/8 in. thick lead backed gypsum panels with beveled, square or tapered edges, applied vertically. Vertical joints centered over studs and staggered min 1 stud cavity on opposite sides of studs. Wallboard secured to studs with 1-1/4 in. long Type S-12 steel screws gypsum panel steel screws spaced 8 in. OC at perimeter and 12 in. OC in the field. Lead batten strips required behind vertical joints of lead backed gypsum wallboard

and optional at remaining stud locations. Lead batten strips, min 2 in. wide, max 8 ft long with a max thickness of 0.14 in. placed on the face of studs and attached to the stud with construction adhesive and two 1 in. long Type S-12 pan head steel screws, one at the top of the strip and one at the bottom of the strip. Lead discs, nominal 3/8 in. diam by max 0.085 in. thick. Compression fitted or adhered over the screw heads. Lead batten strips and discs to have a purity of 99.9% meeting the Federal specification QQ-L-201f, Grade "C".

RADIATION PROTECTION PRODUCTS INC — Type RPP - Lead Lined Drywall

5. Joint Tape and Compound — (Not Shown)

Systems A, B, C, E, F, G, H, I

Joints on outer layers of gypsum boards (Item 4 and 4A) covered with paper tape and joint compound. Paper tape and joint compound may be omitted when gypsum boards are supplied with square edges. Exposed screw heads covered with joint compound.

6. Batts and Blankets* —

Systems A, B, E, F, G, H, I

(Optional) — Mineral wool or glass fiber batts partially or completely filling stud cavity. Any mineral wool or glass fiber batt mineral bearing the UL Classification Marking as to Fire Resistance.

Systems C & D

Min 3 in. (System C) and min 1-1/2 in. (System D) thick mineral wool batts, friction fitted between the studs and floor and ceiling runners.

ROXUL INC — Type AFB

THERMAFIBER INC — Type SAFB

7. Cementitious Backer Units* — (System D) — Nom 1/2 or 5/8 in. thick panels, square edge, attached to studs over gypsum wallboard with 1-5/8 in. long, Type S-12, corrosion resistant steel screws spaced 8 in. OC and staggered 8 in. from gypsum wall board screws. Joints covered with glass fiber mesh tape. Vertical joints staggered one stud cavity from gypsum wallboard joints. Horizontal joints staggered a min of 12 in. from the gypsum wallboard joints.

UNITED STATES GYPSUM CO — Type DCB

8. Laminating Adhesive* — (Optional, Not Shown) — Used to bond outer layer of Cementitious Backer Units (Item 7) to inner layers of Gypsum Board (Item 4) in System D. ANSI A136.1 Type 1 organic adhesive applied with 1/4 in. square notched trowel. See Adhesives (BYWR) in the Fire Resistance Directory or Adhesives (BJLZ) in the Building Materials Directory for names of Classified companies.

9. Lead Batten Strips — (Not Shown, For Use With Item 4A) - Lead batten strips, min 1-1/2 in. wide, max 10 ft long with a max thickness of 0.125 in. Strips placed on the interior face of studs and attached from the exterior face of the stud with two 1 in. long Type S-12 pan head steel screws, one at the top of the strip and one at the bottom of the strip. Lead batten strips to have a purity of 99.9% meeting the Federal specification QQ-L-201f, Grade "C". Lead batten strips required behind vertical joints of lead backed gypsum wallboard (Item 4A) and optional at remaining stud locations. Required behind vertical joints.

9A. Lead Batten Strips — (Not Shown, for use with Item 4C) Lead batten strips, 2 in. wide, max 10 ft long with a max thickness of 0.140 in. Strips placed on the face of studs and attached to the stud with two min. 1 in. long min. Type S-8 pan head steel screws, one at the top of the strip and one at the bottom of the strip or with one min. 1 in. long min. Type S-8 pan head steel screw at the top of the strip. Lead batten strips to have a purity of 99.5% meeting the Federal specification QQ-L-201f, Grades "B, C or D".. Lead batten strips required behind vertical joints of lead backed gypsum wallboard (Item 6) and optional at remaining stud locations.

10. Lead Discs or Tabs — (Not Shown, For Use With Item 4A) - Used in lieu of or in addition to the lead batten strips (Item 9) or optional at other locations - Max 3/4 in. diam by max 0.125 in. thick lead discs compression fitted or adhered over steel screw heads or max 1/2 in. by 1-1/4 in. by max 0.125 in. thick lead tabs placed on gypsum boards (Item 4A) underneath screw locations prior to the installation of the screws. Lead discs or tabs to have a purity of 99.9% meeting the Federal specification QQ-L-201f, Grade "C".

10A. Lead Discs — (Not Shown, for use with Item 4C) Max 5/16 in. diam by max 0.140 in. thick lead discs compression fitted or adhered over steel screw heads. Lead discs to have a purity of 99.5% meeting the Federal Specification QQ-L-201f, Grades "B, C or D".

11. Lead Batten Strips — (Not Shown, For Use With Item 4B) Lead batten strips, 2 in. wide, max 10 ft long with a max thickness of 0.142 in. Strips placed on the face of studs and attached to the stud with two min. 1 in. long min. Type S-8 pan head steel screws, one at the top of the strip and one at the bottom of the strip or with one min. 1 in. long min. Type S-8 pan head steel screw at the top of the strip. Lead batten strips to have a purity of 99.9% meeting the Federal specification QQ-L-201f, Grade "C". Lead batten strips required behind vertical joints of lead backed gypsum wallboard (Item 4B) and optional at remaining stud locations.

12. Lead Tabs — (Not Shown, For Use With Item 4B) 2 in. wide, 5 in. long with a max thickness of 0.142 in. Tabs

friction-fit around front face of stud, the stud folded back flange, and the back face of the stud. Tabs required at each location where a screw (that secures the gypsum boards, Item 4B) will penetrate the steel stud. Lead tabs to have a purity of 99.9% meeting the Federal specification QQ-L-201f, Grade "C". Lead tabs may be held in place with standard adhesive tape if necessary.

*** Indicates such products shall bear the UL or cUL Certification Mark for jurisdictions employing the UL or cUL Certification (such as Canada), respectively.**

Last Updated on 2015-03-16

[Questions?](#)

[Print this page](#)

[Terms of Use](#)

[Page Top](#)

© 2015 UL LLC

When the UL Leaf Mark is on the product, or when the word "Environment" is included in the UL Mark, please search the [UL Environment database](#) for additional information regarding this product's certification.

The appearance of a company's name or product in this database does not in itself assure that products so identified have been manufactured under UL's Follow-Up Service. Only those products bearing the UL Mark should be considered to be Certified and covered under UL's Follow-Up Service. Always look for the Mark on the product.

UL permits the reproduction of the material contained in the Online Certification Directory subject to the following conditions: 1. The Guide Information, Assemblies, Constructions, Designs, Systems, and/or Certifications (files) must be presented in their entirety and in a non-misleading manner, without any manipulation of the data (or drawings). 2. The statement "Reprinted from the Online Certifications Directory with permission from UL" must appear adjacent to the extracted material. In addition, the reprinted material must include a copyright notice in the following format: "© 2015 UL LLC".



Design No. U419 BXUV.U419 Fire Resistance Ratings - ANSI/UL 263

[Page Bottom](#)

Design/System/Construction/Assembly Usage Disclaimer

- Authorities Having Jurisdiction should be consulted in all cases as to the particular requirements covering the installation and use of UL Certified products, equipment, system, devices, and materials.
- Authorities Having Jurisdiction should be consulted before construction.
- Fire resistance assemblies and products are developed by the design submitter and have been investigated by UL for compliance with applicable requirements. The published information cannot always address every construction nuance encountered in the field.
- When field issues arise, it is recommended the first contact for assistance be the technical service staff provided by the product manufacturer noted for the design. Users of fire resistance assemblies are advised to consult the general Guide Information for each product category and each group of assemblies. The Guide Information includes specifics concerning alternate materials and alternate methods of construction.
- Only products which bear UL's Mark are considered Certified.

BXUV - Fire Resistance Ratings - ANSI/UL 263

BXUV7 - Fire Resistance Ratings - CAN/ULC-S101 Certified for Canada

[See General Information for Fire-resistance Ratings - ANSI/UL 263](#)

[See General Information for Fire Resistance Ratings - CAN/ULC-S101 Certified for Canada](#)

Design No. U419

February 25, 2015

Nonbearing Wall Ratings — 1, 2, 3 or 4 Hr (See Items 4 & 5)

*** Indicates such products shall bear the UL or cUL Certification Mark for jurisdictions employing the UL or cUL Certification (such as Canada), respectively.**

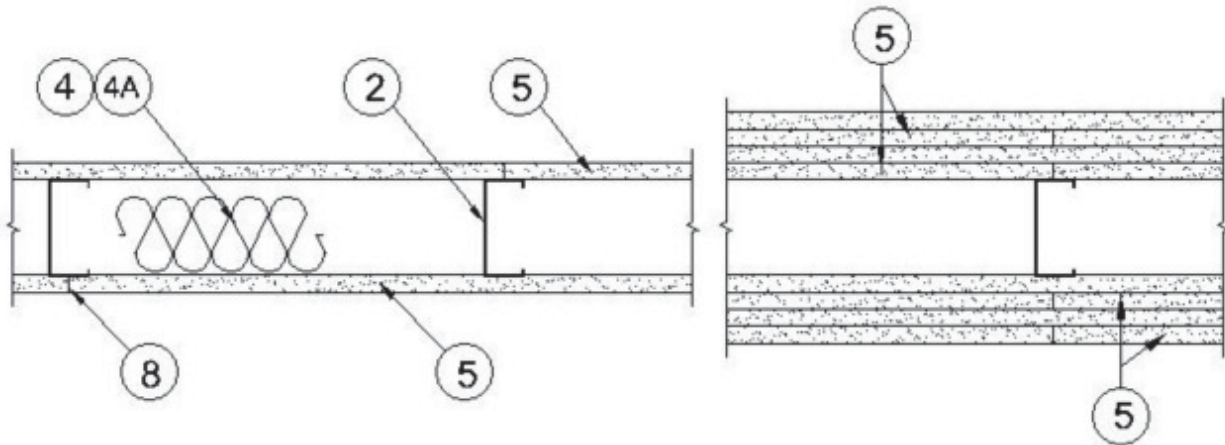

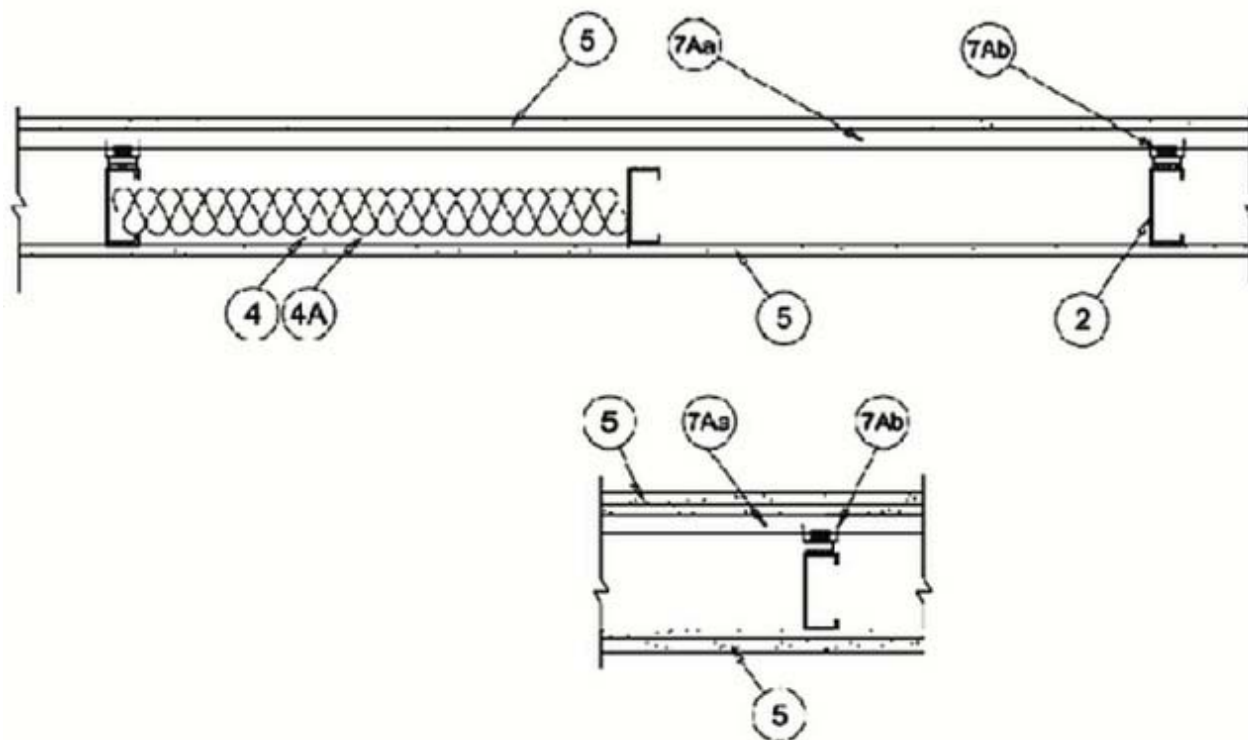

1. **Floor and Ceiling Runners** — (Not shown) — For use with Item 2 - Channel shaped, fabricated from min 25 MSG corrosion-protected steel, min depth to accommodate stud size, with min 1-1/4 in. long legs, attached to floor and ceiling with fasteners 24 in. OC max.

1A. **Framing Members* - Floor and Ceiling Runner** — Not shown - In lieu of Item 1 — For use with Item 2B, proprietary channel shaped runners, 3-5/8 in. deep attached to floor and ceiling with fasteners 24 in. OC max.

CALIFORNIA EXPANDED METAL PRODUCTS CO — Viper25™ Track

CRACO MFG INC — SmartTrack25™

MARINO/WARE, DIV OF WARE INDUSTRIES INC — Viper25™ Track

PHILLIPS MFG CO L L C — Viper25™ Track

1B. **Framing Members* - Floor and Ceiling Runner** — Not shown - In lieu of Item 1 — For use with Item 2C, proprietary channel shaped runners, 1-1/4 in. wide by 3-5/8 in. deep fabricated from min 0.020 in. thick galv steel, attached to floor and ceiling with fasteners spaced 24 in. OC max.

CALIFORNIA EXPANDED METAL PRODUCTS CO — Viper20™ Track

MARINO/WARE, DIV OF WARE INDUSTRIES INC — Viper20™ Track

PHILLIPS MFG CO L L C — Viper20™ Track

1C. **Framing Members*— Floor and Ceiling Runners** — (Not shown) — In lieu of Item 1 - Channel shaped, attached to floor and ceiling with fasteners 24 in. OC. max.

ALLSTEEL & GYPSUM PRODUCTS INC — Type SUPREME Framing System

CONSOLIDATED FABRICATORS CORP, BUILDING PRODUCTS DIV — Type SUPREME Framing System

QUAIL RUN BUILDING MATERIALS INC — Type SUPREME Framing System

SCAFCO STEEL STUD MANUFACTURING CO — Type SUPREME Framing System

STEEL CONSTRUCTION SYSTEMS INC — Type SUPREME Framing System

UNITED METAL PRODUCTS INC — Type SUPREME Framing System

1D. **Floor and Ceiling Runners** — (Not shown)—For use with Item 2A- Channel shaped, fabricated from min 20 MSG corrosion-protected or galv steel, min depth to accommodate stud size, with min 1 in. long legs, attached to floor and ceiling with fasteners spaced max 24 in. OC.

1E. **Framing Members*— Floor and Ceiling Runners** — (Not shown, As an alternate to Item 1) — For use with Items 2E, 5F or 5G or 5I only, channel shaped, fabricated from min. 0.015 in. (min bare metal thickness) galvanized steel, attached to floor and ceiling with fasteners 24 in. OC. max.

CLARKDIETRICH BUILDING SYSTEMS — CD ProTRAK

DMFCWBS L L C — ProTRAK

MBA METAL FRAMING — ProTRAK

RAM SALES L L C — Ram ProTRAK

STEEL STRUCTURAL SYSTEMS L L C — Tri-S ProTRAK

1F. **Framing Members* - Floor and Ceiling Runner** — Not shown - In lieu of Item 1 — For use with Item 2F, proprietary channel shaped runners, minimum width to accommodate stud size, with 1- 1/8 in. long legs fabricated from min 0.015 in. (min bare metal thickness) galv steel, attached to floor and ceiling with fasteners spaced 24 in. OC max.

SUPER STUD BUILDING PRODUCTS — The Edge

1G. **Framing Members* - Floor and Ceiling Runner** — For use with Item 2G, proprietary channel shaped runners, minimum width to accommodate stud size attached to floor and ceiling with fasteners 24 in. OC max.

STUDCO BUILDING SYSTEMS — CROCSTUD Track

1H. **Floor and Ceiling Runners** — (Not shown) — Channel shaped, fabricated from min 0.02 in. galv steel, min width to accommodate stud size, with min 1 in. long legs, for use with studs specified below and fabricated from min 0.02 in. galv steel or thicker, attached to floor and ceiling with fasteners spaced max 24 in. OC.

MARINO/WARE, DIV OF WARE INDUSTRIES INC — Viper20™ Track VT100.

1I. **Framing Members*— Floor and Ceiling Runners** — (Not shown, As an alternate to Item 1) — For use with Items 2H, channel shaped, fabricated from min. 0.015 in. (min bare metal thickness) galvanized steel, attached to floor and ceiling with fasteners 24 in. OC. max.

TELLING INDUSTRIES L L C — TRUE-TRACK™

1J. **Framing Members* - Floor and Ceiling Runner** — Not shown - In lieu of Item 1 — For use with Item 2I, proprietary channel shaped runners, 3-5/8 in. deep attached to floor and ceiling with fasteners 24 in. OC max.

TELLING INDUSTRIES L L C — Viper25™ Track

1K. **Framing Members* - Floor and Ceiling Runner** — Not shown - In lieu of Item 1 — For use with Item 2J, proprietary channel shaped runners, 1-1/4 in. wide by 3-5/8 in. deep fabricated from min 0.020 in. thick galv steel, attached to floor and ceiling with fasteners spaced 24 in. OC max.

TELLING INDUSTRIES L L C — Viper20™ Track

2. **Steel Studs** — Channel shaped, fabricated from min 25 MSG corrosion-protected steel, min depth as indicated under Item 5, spaced a max of 24 in. OC. Studs to be cut 3/8 to 3/4 in. less than assembly height.

2A. **Steel Studs** — (As an alternate to Item 2, For use with Items 5B, 5E, 5H and 5J) Channel shaped, fabricated from min 20 MSG corrosion-protected or galv steel, 3-1/2 in. min depth, spaced a max of 16 in. OC. Studs friction-fit into floor and ceiling runners. Studs to be cut 5/8 to 3/4 in. less than assembly height.

2B. **Framing Members* - Steel Studs** — (As an alternate to Item 2, For use with Items 5C, 5I or 5K) - Proprietary channel shaped studs, 3-5/8 in. deep spaced a max of 24 in. OC. Studs to be cut 3/4 in less than the assembly height and installed with a 1/2 in. gap between the end of the stud and track at the bottom of the wall. For direct attachment of gypsum board only.

CALIFORNIA EXPANDED METAL PRODUCTS CO — Viper25™

CRACO MFG INC — SmartStud25™

MARINO/WARE, DIV OF WARE INDUSTRIES INC — Viper25™

PHILLIPS MFG CO L L C — Viper25™

2C. **Framing Members* - Steel Studs** — Not shown - In lieu of Item 2 — proprietary channel shaped steel studs, min depth as indicated under Item 5, spaced a max if 24 in. OC, fabricated from min 0.020 in. thick galv steel. Studs cut 3/8 in. to 3/4 in. less in lengths than assembly heights.

CALIFORNIA EXPANDED METAL PRODUCTS CO — Viper20™

MARINO/WARE, DIV OF WARE INDUSTRIES INC — Viper20™

PHILLIPS MFG CO L L C — Viper20™

2D. **Framing Members*— Steel Studs** — In lieu of Item 2 - Channel shaped studs, min depth as indicated under Item 5, spaced a max of 24 in. OC. Studs to be cut 3/4 in. less than assembly height.

ALLSTEEL & GYPSUM PRODUCTS INC — Type SUPREME Framing System

CONSOLIDATED FABRICATORS CORP, BUILDING PRODUCTS DIV — Type SUPREME Framing System

QUAIL RUN BUILDING MATERIALS INC — Type SUPREME Framing System

SCAFCO STEEL STUD MANUFACTURING CO — Type SUPREME Framing System

STEEL CONSTRUCTION SYSTEMS INC — Type SUPREME Framing System

UNITED METAL PRODUCTS INC — Type SUPREME Framing System

2E. **Framing Members*— Steel Studs** — (Not shown, As an alternate to Item 2) —For use with Items 5F or 5G or 5I only, channel shaped studs, min depth as indicated under Item 5F, 5G or 5I, fabricated from min. 0.015 in. (min bare metal thickness) galvanized steel, spaced a max of 24 in. OC. Studs to be cut 3/4 in. less than assembly height.

CLARKDIETRICH BUILDING SYSTEMS — CD ProSTUD

DMFCWBS L L C — ProSTUD

MBA METAL FRAMING — ProSTUD

RAM SALES L L C — Ram ProSTUD

STEEL STRUCTURAL SYSTEMS L L C — Tri-S ProSTUD

2F. **Framing Members* - Steel Studs** — Not shown - In lieu of Item 2 — proprietary channel shaped steel studs, minimum width indicated under Item 5, 1-1/4 in. deep fabricated from min 0.015 in. (min bare metal thickness) galvanized steel. Studs 3/8 in. to 3/4 in. less in lengths than assembly heights.

SUPER STUD BUILDING PRODUCTS — The Edge

2G. **Framing Members* - Steel Studs** — Not shown - In lieu of Item 2 - proprietary channel shaped studs, minimum width indicated under Item 5, Studs to be cut 3/8 to 3/4 in less than the assembly height.

STUDCO BUILDING SYSTEMS — CROCSTUD

2H. **Framing Members*— Steel Studs** — (Not shown, As an alternate to Item 2) — Fabricated from min. 0.015 in. (min bare metal thickness) galvanized steel, spaced a max of 24 in. OC. Studs to be cut 3/4 in. less than assembly height.

TELLING INDUSTRIES L L C — TRUE-STUD™

2I. **Framing Members* - Steel Studs** — (As an alternate to Item 2, For use with Items 5C or 5L) - Proprietary channel shaped studs, 3-5/8 in. deep spaced a max of 24 in. OC. Studs to be cut 3/4 in less than the assembly height and installed with a 1/2 in. gap between the end of the stud and track at the bottom of the wall. For direct attachment of gypsum board only.

TELLING INDUSTRIES L L C — Viper25™

2J. **Framing Members* - Metal Studs** — Not shown - In lieu of Item 2 — proprietary channel shaped steel studs, min depth as indicated under Item 5, spaced a max if 24 in. OC, fabricated from min 0.020 in. thick galv steel. Studs cut 3/8 in. to 3/4 in. less in lengths than assembly heights

TELLING INDUSTRIES L L C — Viper20™

2K. **Framing Members*— Steel Studs** — As an alternate to Item 2 - For use with Item 1, channel shaped studs, fabricated from min 25 MSG corrosion-protected steel, min depth as indicated under Item 5, spaced a max of 24 in. OC. Studs to be cut 3/8 to 3/4 in. less than assembly height.

EB MÉTAL INC — EB Stud

2L. **Framing Members*— Steel Studs** — As an alternate to Item 2 - For use with Item 1, channel shaped studs, fabricated from min 25 MSG corrosion-protected steel, min depth as indicated under Item 5, spaced a max of 24 in. OC. Studs to be cut 3/8 to 3/4 in. less than assembly height.

OLMAR SUPPLY INC — PRIMESTUD

3. **Wood Structural Panel Sheathing** — (Optional, For use with Item 5 Only.)- (Not Shown) - 4 ft wide, 7/16 in. thick oriented strand board (OSB) or 15/32 in. thick structural 1 sheathing (plywood) complying with DOC PS1 or PS2, or APA Standard PRP-108, manufactured with exterior glue, applied horizontally or vertically to the steel studs. Vertical joints centered on studs, and staggered one stud space from wallboard joints. Attached to studs with flat-head self-drilling tapping screws with a min. head diam. of 0.292 in. at maximum 6 in. OC. in the perimeter and 12 in. OC. in the field. When used, fastener lengths for gypsum panels increased by min. 1/2 in.

4. **Batts and Blankets*** — (Required as indicated under Item 5) — Mineral wool batts, friction fitted between studs and runners. Min nom thickness as indicated under Item 5. See **Batts and Blankets (BKNV or BZJZ) Categories** for names of Classified companies.

4A. **Batts and Blankets*** — (Optional) — Placed in stud cavities, any glass fiber or mineral wool insulation bearing the UL Classification Marking as to Surface Burning Characteristics and/or Fire Resistance. See **Batts and Blankets (BKNV or BZJZ) Categories** for names of Classified companies.

4B. **Batts and Blankets*** — Placed in stud cavities, any 3-1/2 in. thick glass fiber insulation bearing the UL Classification Marking as to Surface Burning Characteristics and/or Fire Resistance. See **Batts and Blankets (BKNV or BZJZ) Categories** for names of Classified companies.

5. **Gypsum Board*** — Gypsum panels with beveled, square or tapered edges, applied vertically or horizontally. Vertical joints centered over studs and staggered one stud cavity on opposite sides of studs. Vertical joints in adjacent layers (multilayer systems) staggered one stud cavity. Horizontal joints need not be backed by steel framing. Horizontal edge joints and horizontal butt joints on opposite sides of studs need not be staggered. Horizontal edge joints and horizontal butt joints in adjacent layers (multilayer systems) staggered a min of 12 in. The thickness and number of layers for the 1 hr, 2 hr, 3 hr and 4 hr ratings are as follows:

Gypsum Board Protection on Each Side of Wall

Rating, Hr	Min Stud Depth, in. Items 2, 2C, 2D, 2F and 2G	No. of Layers & Thkns of Panel	Min Thkns of Insulation (Item 4)
1	3-1/2	1 layer, 5/8 in. thick	Optional
1	2-1/2	1 layer, 1/2 in. thick	1-1/2 in.
1	1-5/8	1 layer, 3/4 in. thick	Optional
2	1-5/8	2 layers, 1/2 in. thick	Optional
2	1-5/8	2 layers, 5/8 in. thick	Optional
2	3-1/2	1 layer, 3/4 in. thick	3 in.
3	1-5/8	3 layers, 1/2 in. thick	Optional
3	1-5/8	2 layers, 3/4 in. thick	Optional
3	1-5/8	3 layers, 5/8 in. thick	Optional
4	1-5/8	4 layers, 5/8 in. thick	Optional
4	1-5/8	4 layers, 1/2 in. thick	Optional
4	2-1/2	2 layers, 3/4 in. thick	2 in.

CGC INC — 1/2 in. thick Type C, IP-X2 or IPC-AR; WRC, 5/8 in. thick Type AR, C, IP-AR, IP-X1, IP-X2, IPC-AR, SCX, SHX, WRX or WRC; 3/4 in. thick Types IP-X3 or ULTRACODE

UNITED STATES GYPSUM CO — 1/2 in. thick Type C, IP-X2, IPC-AR or WRC; 5/8 in. thick Type SCX, SGX, SHX, WRX, IP-X1, AR, C, WRC, FRX-G, IP-AR, IP-X2, IPC-AR ; 3/4 in. thick Types IP-X3 or ULTRACODE

USG MEXICO S A DE C V — 1/2 in. thick Type C, IP-X2, IPC-AR or WRC; 5/8 in. thick Type AR, C, IP-AR, IP-X1, IP-X2, IPC-AR, SCX, SHX, WRX, WRC or; 3/4 in. thick Types IP-X3 or ULTRACODE

When Item 7B, Steel Framing Members*, is used, Nonbearing Wall Rating is limited to 1 Hr. Min. stud depth is 3-1/2 in., min. thickness of insulation (Item 4) is 3 in., and two layers of gypsum board panels (1/2 in. or 5/8 in. thick) shall be attached to furring channels as described in Item 6. One layer of gypsum board panels (1/2 in. or 5/8 in. thick) attached to opposite side of stud without furring channels as described in Item 6.

5A. **Gypsum Board*** — (As an alternate to Item 5) — 5/8 in. thick, 24 to 54 in. wide, applied horizontally as the outer layer to one side of the assembly. Secured as described in Item 6.

CGC INC — Type SHX.

UNITED STATES GYPSUM CO — Type FRX-G, SHX.

USG MEXICO S A DE C V — Type SHX.

5B. **Gypsum Board*** — (Not Shown) - As an alternate to Item 5 when used as the base layer on one or both sides of wall when 5/8 in or 3/4 in. thick products are specified. For direct attachment only to steel studs Item 2A, (not to be used with Item 3) - Nom 5/8 in. or 3/4 in. may be used as alternate to all 5/8 in. or 3/4 in. shown in Item 5, Wallboard Protection on Each Side of Wall table. Nom 5/8 in. or 3/4 in. thick lead backed gypsum panels with beveled, square or tapered edges, applied vertically. Vertical joints centered over studs and staggered min 1 stud cavity on opposite sides of studs. Gypsum board secured to 20 MSG steel studs Item 2A with 1-1/4 in. long Type S-12 steel screws spaced 8 in. OC at perimeter and 12 in. OC in the field. To be used with Lead Batten Strips (see Item 11) or Lead Discs or Tabs (see Item 12).

RAY-BAR ENGINEERING CORP — Type RB-LBG

5C. **Gypsum Board*** — (For Use With Item 2B) Rating Limited to 1 Hour. 5/8 in. thick, 48 in. wide, Gypsum panels with beveled, square or tapered edges, applied vertically or horizontally. (Vertical Application) - The gypsum board is to be installed on each side of the studs with 1 in. long Type S coated steel screws spaced 8 in. OC starting 4 in. from the edge of the board at the vertical edges and 12 in. OC starting 6 in. from the edge of the board at the center of each board. Gypsum boards are to be secured to the top and bottom track with screws spaced 8 in. OC starting 4 in. from

the board edge. Fasteners shall not penetrate through both the stud and the track at the same time. Vertical joints are to be centered over studs and staggered one stud cavity on opposite sides of studs. (Horizontal Application) - The gypsum board is to be installed on each side of the studs with 1 in. long Type S coated steel screws spaced 8 in. OC starting 4 in. from the edge of the board at the vertical edges and 12 in. OC starting 6 in. from the edge of the board at the center of each board. Gypsum boards are to be secured to the top and bottom track with screws spaced 8 in. OC starting 4 in. from the board edge. Fasteners shall not penetrate through both the stud and the track at the same time. All horizontal joints are to be backed as outlined under section VI of Volume 1 in the Fire Resistive Directory.

CGC INC — Type SCX.

UNITED STATES GYPSUM CO — Type SCX, SGX.

USG MEXICO S A DE C V — Type SCX.

5D. **Gypsum Board*** — (As an alternate to Item 5) — 5/8 in. thick, 48 in. wide, applied vertically or horizontally. Secured as described in Item 6. For use with Items 1 and 2 only.

UNITED STATES GYPSUM CO — Type USGX.

5E. **Gypsum Board*** — (Not Shown) - (As an alternate to Item 5 when used as the base layer on one or both sides of wall when 1/2 in. or 5/8 in thick products are specified, For direct attachment only to steel studs Item 2A, not to be used with Item 3). Nominal 5/8 in. thick lead backed gypsum panels with beveled, square or tapered edges, applied vertically. Vertical joints centered over studs and staggered min 1 stud cavity on opposite sides of studs. Wallboard secured to studs with 1-1/4 in. long Type S-12 (or No. 6 by 1-1/4 in. long bugle head fine driller) steel screws spaced 8 in. OC at perimeter and 12 in. OC in the field.

NEW ENGLAND LEAD BURNING CO INC, DBA NELCO — Nelco

5F. **Gypsum Board*** — (As an alternate to Item 5) — For use with Items 1E and 2E and limited to 1 Hour Rating only, Gypsum panels with beveled, square or tapered edges, applied vertically, and fastened to the steel studs with 1 in. long Type S screws spaced 8 in. OC along vertical and bottom edges and 12 in. OC in the field. Vertical joints centered over studs and staggered one stud cavity on opposite sides of studs. Steel stud depth shall be a minimum 3-5/8 in.

UNITED STATES GYPSUM CO — 5/8 in. thick Type SCX, SGX.

5G. **Gypsum Board*** — (As an alternate to Item 5) — For use with Items 1E and 2E only, Gypsum panels with beveled, square or tapered edges, applied vertically or horizontally, as specified in the table below and fastened to the steel studs as described in Item 6. Vertical joints centered over studs and staggered one stud cavity on opposite sides of studs. Vertical joints in adjacent layers (multilayer systems) staggered one stud cavity. Horizontal joints need not be backed by steel framing. Horizontal edge joints and horizontal butt joints on opposite sides of studs need not be staggered. Horizontal edge joints and horizontal butt joints in adjacent layers (multilayer systems) staggered a min of 12 in. The thickness and number of layers for the 2 hr, 3 hr and 4 hr ratings are as follows:

Gypsum Board Protection on Each Side of Wall

Rating, Hr	Min Stud Depth, in. Item 2E	No. of Layers & Thickness of Panel	Min Thkns of Insulation (Item 4)
2	1-5/8	2 layers, 1/2 in. thick	Optional
2	1-5/8	2 layers, 5/8 in. thick	Optional
3	1-5/8	3 layers, 1/2 in. thick	Optional
3	1-5/8	3 layers, 5/8 in. thick	Optional
4	1-5/8	4 layers, 5/8 in. thick	Optional
4	1-5/8	4 layers, 1/2 in. thick	Optional

CGC INC — 1/2 in. thick Type C, IP-X2 or IPC-AR; 5/8 in. thick Type AR, C, IP-AR, IP-X1, IP-X2, IPC-AR, SCX, SHX, or; 3/4 in. thick Types IP-X3 or ULTRACODE

UNITED STATES GYPSUM CO — 1/2 in. thick Type C, IP-X2, IPC-AR or; 5/8 in. thick Type SCX, SGX, SHX, IP-X1, AR, C, , FRX-G, IP-AR, IP-X2, IPC-AR ; 3/4 in. thick Types IP-X3 or ULTRACODE

USG MEXICO S A DE C V — 1/2 in. thick Type C, IP-X2, IPC-AR or; 5/8 in. thick Type AR, C, IP-AR, IP-X1, IP-X2,

IPC-AR, SCX, SHX, or; 3/4 in. thick Types IP-X3 or ULTRACODE

5H. **Gypsum Board*** — (Not Shown) - (As an alternate to Item 5 when used as the base layer on one or both sides of wall when 5/8 or 3/4 in thick products are specified. For direct attachment only to steel studs Item 2A, (not to be used with Item 3) - Nom 5/8 or 3/4 in. may be used as alternate to all 5/8 or 3/4 in. shown in Item 5, Wallboard Protection on Each Side of Wall table. Nom 5/8 or 3/4 in. thick lead backed gypsum panels with beveled, square or tapered edges, applied vertically. Vertical joints centered over 20 MSG steel studs and staggered min 1 stud cavity on opposite sides of studs. Wallboard secured to studs with 1-1/4 in. long Type S-12 steel screws spaced 8 in. OC at perimeter and 12 in. OC in the field. Gypsum board secured to 20 MSG steel studs Item 2B with 1-1/4 in. long Type S-12 steel screws spaced 8 in. OC at perimeter and 12 in. OC in the field. For Joint Compound see Item 5. To be used with Lead Batten Strips (see Item 11A) or Lead Discs (see Item 12A).

MAYCO INDUSTRIES INC — Type X-Ray Shielded Gypsum

5I. **Gypsum Board*** — (As an alternate to Item 5) - Nom. 5/8 in. thick gypsum panels with beveled, square or tapered edges installed as described in Item 5. Steel stud minimum depth shall be as indicated in Item 5.

CGC INC — Type ULX

UNITED STATES GYPSUM CO — Type ULX

USG MEXICO S A DE C V — Type ULX

5J. **Gypsum Board*** — (Not Shown) - (As an alternate to Item 5 when used as the base layer on one or both sides of wall when 1/2 in. or 5/8 in thick products are specified, For direct attachment only to steel studs Item 2A, not to be used with Item 3). Nom 5/8 in. thick lead backed gypsum panels with beveled, square or tapered edges, applied vertically. Vertical joints centered over studs and staggered min 1 stud cavity on opposite sides of studs. Wallboard secured to studs with 1-1/4 in. long Type S-12 steel screws gypsum panel steel screws spaced 8 in. OC at perimeter and 12 in. OC in the field. Lead batten strips required behind vertical joints of lead backed gypsum wallboard and optional at remaining stud locations. Lead batten strips, min 2 in. wide, max 8 ft long with a max thickness of 0.14 in. placed on the face of studs and attached to the stud with construction adhesive and two 1 in. long Type S-12 pan head steel screws, one at the top of the strip and one at the bottom of the strip. Lead discs, nominal 3/8 in. diam by max 0.085 in. thick. Compression fitted or adhered over the screw heads. Lead batten strips and discs to have a purity of 99.9% meeting the Federal specification QQ-L-201f, Grade "C".

RADIATION PROTECTION PRODUCTS INC — Type RPP - Lead Lined Drywall

5K. **Gypsum Board*** — Nom. 5/8 in. thick gypsum panels with beveled, square or tapered edges installed as described in Item 5. Insulation (Item 4B) required. The steel stud size and type and number of layers are as follows:

Gypsum Board Protection on Each Side of Wall

Rating, Hr	Min Stud Depth, in. Items 2, 2B	No. of Layers & Thickness of Panel
1	3-5/8	1 layer, 5/8 in. thick

UNITED STATES GYPSUM CO — 5/8 in. thick Type ULIX

6. **Fasteners** — (Not shown) — For use with Items 2 and 2F - Type S or S-12 steel screws used to attach panels to studs (Item 2) or furring channels (Item 7). **Single layer systems:** 1 in. long for 1/2 and 5/8 in. thick panels or 1-1/4 in. long for 3/4 in. thick panels, spaced 8 in. OC when panels are applied horizontally, or 8 in. OC along vertical and bottom edges and 12 in. OC in the field when panels are applied vertically. **Two layer systems:** First layer- 1 in. long for 1/2 and 5/8 in. thick panels or 1-1/4 in. long for 3/4 in. thick panels, spaced 16 in. OC. Second layer- 1-5/8 in. long for 1/2 in., 5/8 in. thick panels or 2-1/4 in. long for 3/4 in. thick panels, spaced 16 in. OC with screws offset 8 in. from first layer. **Three-layer systems:** First layer- 1 in. long for 1/2 in., 5/8 in. thick panels, spaced 24 in. OC. Second layer- 1-5/8 in. long for 1/2 in., 5/8 in. thick panels, spaced 24 in. OC. Third layer- 2-1/4 in. long for 1/2 in., 5/8 in. thick panels or 2-5/8 in. long for 5/8 in. thick panels, spaced 12 in. OC. Screws offset min 6 in. from layer below. **Four-layer systems:** First layer- 1 in. long for 1/2 in., 5/8 in. thick panels, spaced 24 in. OC. Second layer- 1-5/8 in. long for 1/2 in., 5/8 in. thick panels, spaced 24 in. OC. Third layer- 2-1/4 in. long for 1/2 in. thick panels or 2-5/8 in. long for 5/8 in. thick panels, spaced 24 in. OC. Fourth layer- 2-5/8 in. long for 1/2 in. thick panels or 3 in. long for 5/8 in. thick panels, spaced 12 in. OC. Screws offset min 6 in. from layer below.

7. **Furring Channels** — (Optional, not shown, for single or double layer systems) — Resilient furring channels fabricated from min 25 MSG corrosion-protected steel, spaced vertically a max of 24 in. OC. Flange portion attached to each intersecting stud with 1/2 in. long Type S-12 steel screws. Not for use with Item 5A and 5E.

7A. **Framing Members*** — (Optional on one or both sides, not shown, for single or double layer systems) — As an

alternate to Item 7, furring channels and Steel Framing Members as described below:

a. **Furring Channels** — Formed of No. 25 MSG galv steel. 2-9/16 in. or 2-23/32 in. wide by 7/8 in. deep, spaced max. 24 in. OC perpendicular to studs. Channels secured to studs as described in Item b. Gypsum board attached to furring channels as described in Item 6. Not for use with Item 5A and 5E.

b. **Steel Framing Members*** — Used to attach furring channels (Item 7Aa) to studs (Item 2). Clips spaced max. 48 in. OC. RSIC-1 and RSIC-1 (2.75) clips secured to studs with No. 8 x 1-1/2 in. minimum self-drilling, S-12 steel screw through the center grommet. RSIC-V and RSIC-V (2.75) clips secured to studs with No. 8 x 9/16 in. minimum self-drilling, S-12 steel screw through the center hole. Furring channels are friction fitted into clips. RSIC-1 and RSIC-V clips for use with 2-9/16 in. wide furring channels. RSIC-1 (2.75) and RSIC-V (2.75) clips for use with 2-23/32 in. wide furring channels.

PAC INTERNATIONAL INC — Types RSIC-1, RSIC-V, RSIC-1 (2.75), RSIC-V (2.75).

7B. **Framing Members*** — (Optional, Not Shown) — As an alternate to Item 7, for single or double layer systems, furring channels and Steel Framing Members on only one side of studs as described below:

a. **Furring Channels** — Formed of No. 25 MSG galv steel, spaced 24 in. OC perpendicular to studs. Channels secured to studs as described in Item b. Batts and Blankets placed in stud cavity as described in Item 5. Two layers of gypsum board attached to furring channels as described in Item 5. Not for use with Item 5A and 5E.

b. **Steel Framing Members*** — Used to attach furring channels (Item 7Ba) to one side of studs (Item 2) only. Clips spaced 48 in. OC., and secured to studs with two No. 8 x 2-1/2 in. coarse drywall screws, one through the hole at each end of the clip. Furring channels are friction fitted into clips.

KINETICS NOISE CONTROL INC — Type Isomax

7C. **Framing Members*** — (Not Shown) — (Optional on one or both sides, not shown, for single or double layer systems) — As an alternate to Item 7, furring channels and Steel Framing Members as described below:

a. **Furring Channels** — Formed of No. 25 MSG galv steel. 2-3/8 in. wide by 7/8 in. deep, spaced max. 24 in. OC perpendicular to studs. Channels secured to studs as described in Item b. Gypsum board attached to furring channels as described in Item 6. Not for use with Item 5A and 5E.

b. **Steel Framing Members*** — Used to attach furring channels (Item 7Aa) to studs (Item 2). Clips spaced max. 48 in. OC. GENIECLIPS secured to studs with No. 8 x 1-1/2 in. minimum self-drilling, S-12 steel screw through the center grommet. Furring channels are friction fitted into clips.

PLITEQ INC — Type GENIECLIP

7D. **Steel Framing Members** — (Optional, Not Shown)* - Furring channels and resilient sound isolation clip as described below:

a. **Furring Channels** — Formed of No. 25 MSG galv steel. Spaced 24 in. OC perpendicular to studs. Channels secured to studs as described in Item b. Ends of adjoining channels overlapped 6 in. and secured together with four self-tapping No. 8x1/2 Self Drilling screws (2 per side 1 in. and 4 in. from overlap edge). Gypsum board attached to furring channels as described in Item 4. Side joint furring channels shall be attached to studs with RESILMOUNT Sound Isolation Clips - located approximately 2 in. from each end of length of channel. Both Gypsum Boards at side joints fastened into channel with screws spaced 8 in. OC, approximately 1/2 in. from joint edge. Not for use with Item 5A and 5E.

b. **Steel Framing Members*** — Resilient sound isolation clip used to attach furring channels (Item 7Da) to studs. Clips spaced 24 in. OC., and secured to studs with No. 10 x 2-1/2 in. coarse drywall screw through the center hole. Furring channels are friction fitted into clips.

STUDCO BUILDING SYSTEMS — RESILMOUNT Sound Isolation Clips - Type A237 or A237R

8. **Joint Tape and Compound** — Vinyl or casein, dry or premixed joint compound applied in two coats to joints and screw heads of outer layers. Paper tape, nom 2 in. wide, embedded in first layer of compound over all joints of outer layer panels. Paper tape and joint compound may be omitted when gypsum panels are supplied with a square edge.

9. **Siding, Brick or Stucco** — (Optional, not shown) — Aluminum, vinyl or steel siding, brick veneer or stucco, meeting the requirements of local code agencies, installed over gypsum panels. Brick veneer attached to studs with corrugated metal wall ties attached to each stud with steel screws, not more than each sixth course of brick.

10. **Caulking and Sealants*** — (Optional, not shown) — A bead of acoustical sealant applied around the partition perimeter for sound control.

UNITED STATES GYPSUM CO — Type AS

11. **Lead Batten Strips** — (Not Shown, For Use With Item 5B) - Lead batten strips, min 1-1/2 in. wide, max 10 ft long with a max thickness of 0.125 in. Strips placed on the interior face of studs and attached from the exterior face of the stud with two 1 in. long Type S-12 pan head steel screws, one at the top of the strip and one at the bottom of the strip. Lead batten strips to have a purity of 99.9% meeting the Federal specification QQ-L-201f, Grade "C". Lead batten strips required behind vertical joints of lead backed gypsum wallboard (Item 5B) and optional at remaining stud locations. Required behind vertical joints.

11A. **Lead Batten Strips** — (Not Shown, For Use With Item 5H) Lead batten strips, 2 in. wide, max 10 ft long with a max thickness of 0.140 in. Strips placed on the face of studs and attached to the stud with two min. 1 in. long min. Type S-8 pan head steel screws, one at the top of the strip and one at the bottom of the strip or with one min. 1 in. long min. Type S-8 pan head steel screw at the top of the strip. Lead batten strips to have a purity of 99.5% meeting the Federal specification QQ-L-201f, Grades "B, C or D". Lead batten strips required behind vertical joints of lead backed gypsum wallboard and optional at remaining stud locations.

12. **Lead Discs or Tabs** — (Not Shown, For Use With Item 5B) - Used in lieu of or in addition to the lead batten strips (Item 11) or optional at other locations - Max 3/4 in. diam by max 0.125 in. thick lead discs compression fitted or adhered over steel screw heads or max 1/2 in. by 1-1/4 in. by max 0.125 in. thick lead tabs placed on gypsum boards (Item 5B) underneath screw locations prior to the installation of the screws. Lead discs or tabs to have a purity of 99.9% meeting the Federal specification QQ-L-201f, Grade "C".

12A. **Lead Discs** — (Not Shown, for use with Item 5H) Max 5/16 in. diam by max 0.140 in. thick lead discs compression fitted or adhered over steel screw heads. Lead discs to have a purity of 99.5% meeting the Federal Specification QQ-L-201f, Grades "B, C or D".

13. **Lead Batten Strips** — (Not Shown, For Use With Item 5E) Lead batten strips, 2 in. wide, max 10 ft long with a max thickness of 0.142 in. Strips placed on the face of studs and attached to the stud with two min. 1 in. long min. Type S-8 pan head steel screws, one at the top of the strip and one at the bottom of the strip or with one min. 1 in. long min. Type S-8 pan head steel screw at the top of the strip. Lead batten strips to have a purity of 99.9% meeting the Federal specification QQ-L-201f, Grade "C". Lead batten strips required behind vertical joints of lead backed gypsum wallboard (Item 5E) and optional at remaining stud locations.

14. **Lead Tabs** — (Not Shown, For Use With Item 5E) 2 in. wide, 5 in. long with a max thickness of 0.142 in. Tabs friction-fit around front face of stud, the stud folded back flange, and the back face of the stud. Tabs required at each location where a screw (that secures the gypsum boards, Item 5E) will penetrate the steel stud. Lead tabs to have a purity of 99.9% meeting the Federal specification QQ-L-201f, Grade "C". Lead tabs may be held in place with standard adhesive tape if necessary.

*** Indicates such products shall bear the UL or cUL Certification Mark for jurisdictions employing the UL or cUL Certification (such as Canada), respectively.**

Last Updated on 2015-02-25

[Questions?](#)

[Print this page](#)

[Terms of Use](#)

[Page Top](#)

© 2015 UL LLC

When the UL Leaf Mark is on the product, or when the word "Environment" is included in the UL Mark, please search the [UL Environment database](#) for additional information regarding this product's certification.

The appearance of a company's name or product in this database does not in itself assure that products so identified have been manufactured under UL's Follow-Up Service. Only those products bearing the UL Mark should be considered to be Certified and covered under UL's Follow-Up Service. Always look for the Mark on the product.

UL permits the reproduction of the material contained in the Online Certification Directory subject to the following conditions: 1. The Guide Information, Assemblies, Constructions, Designs, Systems, and/or Certifications (files) must be presented in their entirety and in a non-misleading manner, without any manipulation of the data (or drawings). 2. The statement "Reprinted from the Online Certifications Directory with permission from UL" must appear adjacent to the extracted material. In addition, the reprinted material must include a copyright notice in the following format: "© 2015 UL LLC".



Design No. U465 BXUV.U465 Fire Resistance Ratings - ANSI/UL 263

[Page Bottom](#)

Design/System/Construction/Assembly Usage Disclaimer

- Authorities Having Jurisdiction should be consulted in all cases as to the particular requirements covering the installation and use of UL Certified products, equipment, system, devices, and materials.
- Authorities Having Jurisdiction should be consulted before construction.
- Fire resistance assemblies and products are developed by the design submitter and have been investigated by UL for compliance with applicable requirements. The published information cannot always address every construction nuance encountered in the field.
- When field issues arise, it is recommended the first contact for assistance be the technical service staff provided by the product manufacturer noted for the design. Users of fire resistance assemblies are advised to consult the general Guide Information for each product category and each group of assemblies. The Guide Information includes specifics concerning alternate materials and alternate methods of construction.
- Only products which bear UL's Mark are considered Certified.

BXUV - Fire Resistance Ratings - ANSI/UL 263

BXUV7 - Fire Resistance Ratings - CAN/ULC-S101 Certified for Canada

[See General Information for Fire-resistance Ratings - ANSI/UL 263](#)

[See General Information for Fire Resistance Ratings - CAN/ULC-S101 Certified for Canada](#)

Design No. U465

April 08, 2015

Nonbearing Wall Rating — 1 HR.

*** Indicates such products shall bear the UL or cUL Certification Mark for jurisdictions employing the UL or cUL Certification (such as Canada), respectively.**

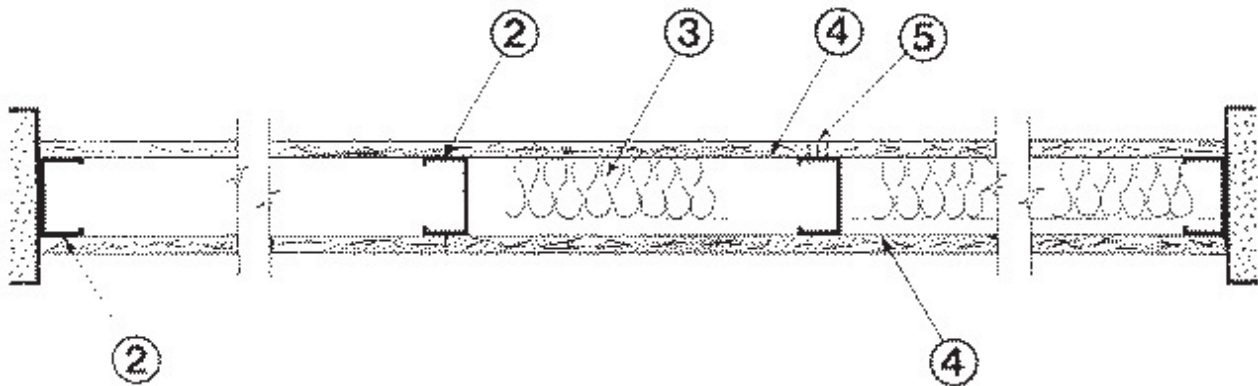

1. Floor and Ceiling Runners — (Not shown) — Channel shaped runners, 3-5/8 in. deep (min), 1-1/4 in. legs, formed from min No. 25 MSG galv steel, attached to floor and ceiling with fasteners spaced 24 in. OC max.

1A. Framing Members*— Floor and Ceiling Runners — (Not shown) — As an alternate to Item 1 - Channel shaped, min 3-5/8 in. deep, attached to floor and ceiling with fasteners 24 in. OC. max.

ALLSTEEL & GYPSUM PRODUCTS INC — Type SUPREME Framing System

CONSOLIDATED FABRICATORS CORP, BUILDING PRODUCTS DIV — Type SUPREME Framing System

QUAIL RUN BUILDING MATERIALS INC — Type SUPREME Framing System

SCAFCO STEEL STUD MANUFACTURING CO — Type SUPREME Framing System

STEEL CONSTRUCTION SYSTEMS INC — Type SUPREME Framing System

UNITED METAL PRODUCTS INC — Type SUPREME Framing System

1B. Framing Members* - Floor and Ceiling Runners — Not shown - In lieu of Item 1 — For use with Item 2B, proprietary channel shaped runners, 1-1/4 in. wide by min 3-5/8 in. deep fabricated from min 0.020 in. thick galv steel, attached to floor and ceiling with fasteners spaced 24 in. OC max.

CALIFORNIA EXPANDED METAL PRODUCTS CO — Viper20™ Track

CRACO MFG INC — SmartTrack20™

MARINO/WARE, DIV OF WARE INDUSTRIES INC — Viper20™ Track

PHILLIPS MFG CO L L C — Viper20™ Track

1C. Floor and Ceiling Runners — (Not shown)—For use with Item 2C- Channel shaped, fabricated from min 20 MSG corrosion-protected or galv steel, min depth to accommodate stud size, with min 1 in. long legs, attached to floor and ceiling with fasteners spaced max 24 in. OC.

1D. Framing Members*— Floor and Ceiling Runners — Not shown - In lieu of Items 1 through 1C — For use with Item 2D and 4G only, proprietary channel shaped runners, 1-1/4 in. deep by min 3-5/8 in. wide fabricated from min 0.018 in. thick galv steel, attached to floor and ceiling with fasteners spaced 24 in. OC max.

CLARKDIETRICH BUILDING SYSTEMS — CD ProTRAK

DMFCWBS L L C — ProTRAK

MBA METAL FRAMING — ProTRAK

RAM SALES L L C — Ram ProTRAK

STEEL STRUCTURAL SYSTEMS L L C — Tri-S ProTRAK

1E. Framing Members*— Floor and Ceiling Runners — Not shown - In lieu of Items 1 through 1D — For use with Item 2E and 4I only, proprietary channel shaped runners, 1-1/4 in. deep by min 3-5/8 in. wide fabricated from min 0.018 in. thick galv steel, attached to floor and ceiling with fasteners spaced 24 in. OC max.

TELLING INDUSTRIES L L C — TRUE-TRACK™

1F. Framing Members*— Floor and Ceiling Runners — Not shown - In lieu of Items 1 through 1E — For use with Item 2, channel shaped runners, 1-1/4 in. deep by min 3-5/8 in. wide fabricated from min 25 MSG steel, attached to floor and ceiling with fasteners spaced 24 in. OC max.

KIRII (HONG KONG) LTD — Type KIRII

1G. Framing Members*— Floor and Ceiling Runners — Not shown - In lieu of Items 1 through 1F — For use with Item 2, channel shaped runners, 1-1/4 in. deep by min 3-5/8 in. wide, attached to floor and ceiling with fasteners spaced 24 in. OC max.

STUDCO BUILDING SYSTEMS — CROCSTUD Track

1H. Floor and Ceiling Runners — (Not shown) — Channel shaped, fabricated from min 0.02 in. galv steel, min width to accommodate stud size, with min 1 in. long legs, for use with studs specified below and fabricated from min 0.02 in. galv steel or thicker, attached to floor and ceiling with fasteners spaced max 24 in. OC.

MARINO/WARE, DIV OF WARE INDUSTRIES INC — Viper20™ Track VT100.

1I. **Framing Members* - Floor and Ceiling Runners** — Not shown - In lieu of Item 1 — For use with Item 2H, proprietary channel shaped runners, 1-1/4 in. wide by min 3-5/8 in. deep fabricated from min 0.020 in. thick galv steel, attached to floor and ceiling with fasteners spaced 24 in. OC max.

TELLING INDUSTRIES L L C — Viper20™ Track

2. **Steel Studs** — Channel shaped, 3-5/8 in. deep (min), formed from min No. 25 MSG galv steel spaced 24 in. OC max. Studs to be cut 3/4 in. less than assembly height.

2A. **Framing Members*— Steel Studs** — As an alternate to Item 2 - Channel shaped studs, min 3-5/8 in. deep, spaced a max of 24 in. OC. Studs to be cut 3/4 in. less than assembly height.

ALLSTEEL & GYPSUM PRODUCTS INC — Type SUPREME Framing System

CONSOLIDATED FABRICATORS CORP, BUILDING PRODUCTS DIV — Type SUPREME Framing System

QUAIL RUN BUILDING MATERIALS INC — Type SUPREME Framing System

SCAFCO STEEL STUD MANUFACTURING CO — Type SUPREME Framing System

STEEL CONSTRUCTION SYSTEMS INC — Type SUPREME Framing System

UNITED METAL PRODUCTS INC — Type SUPREME Framing System

2B. **Framing Members* - Steel Studs** — Not shown - In lieu of Item 2 — For use with Item 1B, proprietary channel shaped steel studs, 1-1/4 in. wide by min 3-5/8 in. deep fabricated from min 0.020 in. thick galv steel. Studs cut 3/4 in. less in length than assembly height.

CALIFORNIA EXPANDED METAL PRODUCTS CO — Viper20™

CRACO MFG INC — SmartStud20™

MARINO/WARE, DIV OF WARE INDUSTRIES INC — Viper20™

PHILLIPS MFG CO L L C — Viper20™

2C. **Steel Studs** — (As an alternate to Item 2, For use with Item 4E) Channel shaped, fabricated from min 20 MSG corrosion-protected or galv steel, 3-1/2 in. min depth, spaced a max of 16 in. OC. Studs friction-fit into floor and ceiling runners. Studs to be cut 5/8 to 3/4 in. less than assembly height.

2D. **Framing Members*— Steel Studs** — As an alternate to Items 2 through 2C- For use with Item 1D and 4G only, channel shaped studs, min 3-5/8 in. wide fabricated from min 0.018 in. thick galv steel, spaced a max of 24 in. OC. Studs to be cut 1/2 in. less than assembly height.

CLARKDIETRICH BUILDING SYSTEMS — CD ProSTUD

DMFCWBS L L C — ProSTUD

MBA METAL FRAMING — ProSTUD

RAM SALES L L C — Ram ProSTUD

STEEL STRUCTURAL SYSTEMS L L C — Tri-S ProSTUD

2E. **Framing Members*— Steel Studs** — As an alternate to Items 2 through 2D- For use with Item 1E and 4I only, channel shaped studs, min 3-5/8 in. wide fabricated from min 0.018 in. thick galv steel, spaced a max of 24 in. OC. Studs to be cut 1/2 in. less than assembly height.

TELLING INDUSTRIES L L C — TRUE-STUD™

2F. **Framing Members*— Steel Studs** — As an alternate to Items 2 through 2E- For use with Item 1F, channel shaped studs, min 3-5/8 in. wide fabricated from min 25 MSG steel, spaced a max of 24 in. OC. Studs to be cut 1/2 in. less than assembly height.

KIRII (HONG KONG) LTD — Type KIRII

2G. **Framing Members* - Steel Studs** — Not shown - In lieu of Item 2 through 2F - For use with Item 1G. Proprietary channel shaped studs, minimum 3-5/8 in. wide, Studs to be cut 1/2 in. less than the assembly height.

STUDCO BUILDING SYSTEMS — CROCSTUD

2H. **Framing Members* - Steel Studs** — Not shown - In lieu of Item 2 — For use with Item 1I, proprietary channel shaped steel studs, 1-1/4 in. wide by min 3-5/8 in. deep fabricated from min 0.020 in. thick galv steel. Studs cut 3/4 in. less in length than assembly height.

TELLING INDUSTRIES L L C — Viper20™

2I. **Framing Members* — Steel Studs** — In lieu of Item 2 - For use with Item 1, channel shaped studs, fabricated from min 25 MSG corrosion-protected steel, 3-5/8 in. deep (min), spaced 24 in. OC max. Studs to be cut 3/4 in. less than assembly height.

EB MÉTAL INC — EB Stud

2J. **Framing Members* — Steel Studs** — In lieu of Item 2 - For use with Item 1, channel shaped studs, fabricated from min 25 MSG corrosion-protected steel, 3-5/8 in. deep (min), spaced 24 in. OC max. Studs to be cut 3/4 in. less than assembly height.

OLMAR SUPPLY INC — PRIMESTUD

3. **Batts and Blankets*** — (Optional) — Mineral wool or glass fiber batts partially or completely filling stud cavity.

See **Batts and Blankets** (BZJZ) category for names of Classified companies.

3A. **Fiber, Sprayed*** — As an alternate to Batts and Blankets (Item 3) — (100% Borate Formulation) — Spray applied cellulose material. The fiber is applied with water to completely fill the enclosed cavity in accordance with the application instructions supplied with the product with a nominal dry density of 2.7 lb/ft³. Alternate Application Method: The fiber is applied without water or adhesive at a nominal dry density of 3.5 lb/ft³, in accordance with the application instructions supplied with the product.

U S GREENFIBER L L C — INS735 & INS745 for use with wet or dry application. INS765LD and INS770LD are to be used for dry application only.

3B. **Fiber, Sprayed*** — As an alternate to Batts and Blankets (Item 3) and Item 3A - Spray applied cellulose insulation material. The fiber is applied with water to interior surfaces in accordance with the application instructions supplied with the product. Applied to completely fill the enclosed cavity. Minimum dry density of 4.3 pounds per cubic ft.

NU-WOOL CO INC — Cellulose Insulation

3C. **Fiber, Sprayed*** — As an alternate to Batts and Blankets (Item 3) - Spray applied cellulose fiber. The fiber is applied with water to completely fill the enclosed cavity in accordance with the application instructions supplied with the product. The minimum dry density shall be 4.30 lbs/ft³.

INTERNATIONAL CELLULOSE CORP — Celbar-RL

3D. **Batts and Blankets*** — For use with Item 8. Nom 3 in. thick, minimum 3.4 pcf mineral wool batts, friction fit between the studs and floor and ceiling runners.

See **Batts and Blankets** (BZJZ) category for names of manufacturers.

4. **Gypsum Board*** — 5/8 in. thick, 4 ft wide, attached to steel studs and floor and ceiling track with 1 in. long, Type S steel screws spaced 8 in. OC. along edges of board and 12 in. OC in the field of the board. Joints oriented vertically

and staggered on opposite sides of the assembly. When attached to item 6 (resilient channels) or 6A, 6B or 6C (furring channels), gypsum board is screw attached to furring channels with 1 in. long, Type S steel screws spaced 12 in. OC.

ACADIA DRYWALL SUPPLIES LTD — Type X, 5/8 Type X, Type Blueglass Exterior Sheathing

AMERICAN GYPSUM CO — Types AG-C, AGX-1, M-Glass

BEIJING NEW BUILDING MATERIALS PUBLIC LTD CO — Type DBX-1.

CGC INC — Types AR, C, IP-AR, IP-X1, IP-X2, IPC-AR, SCX, SHX, WRC or WRX.

CERTAINTED GYPSUM INC — Types 1, EGRG, GlasRoc, Type X, Type C, SilentFX, 5/8" Easi-Lite Type X.

CONTINENTAL BUILDING PRODUCTS OPERATING CO, L L C — Types LGFC2A, LGFC6A, LGFC-C/A, LGFC-WD, LGLLX.

GEORGIA-PACIFIC GYPSUM L L C — Types 5, 6, 9, C, DAP, DD, DA, DAPC, DGG, DS, GPFS6, LS, , Type X, Veneer Plaster Base - Type X, Water Rated - Type X, Sheathing - Type X, Soffit - Type X, TG-C, GreenGlass Type X, Type X ComfortGuard Sound Deadening Gypsum Board, Type LWX, Veneer Plaster Base-Type LWX, Water Rated-Type LWX, Sheathing Type-LWX, Soffit-Type LWX, Type DGLW, Water Rated-Type DGLW, Sheathing Type- DGLW, Soffit-Type DGLW, Type LW2X, Veneer Plaster Base - Type LW2X, Water Rated - Type LW2X, Sheathing - Type LW2X, Soffit - Type LW2X, Type DGL2W, Water Rated - Type DGL2W, Sheathing - Type DGL2W.

NATIONAL GYPSUM CO — Types eXP-C, FSK, FSK-C, FSK-G, FSMR-C, FSW-C, FSW-G, FSW, FSW-3, FSW-5, FSW-6, FSW-8, FSL.

PABCO BUILDING PRODUCTS L L C, DBA PABCO GYPSUM — Types PG-C, PG-9, PG-11, PGS-WRS.

PANEL REY S A — Types GREX, PRX, RHX, MDX, ETX.

SIAM GYPSUM INDUSTRY (SARABURI) CO LTD — Type EX-1

THAI GYPSUM PRODUCTS PCL — Type X, Type C.

UNITED STATES GYPSUM CO — Type AR, C, FRX-G, IP-AR, IP-X1, IP-X2, IPC-AR, SCX, SHX, WRC, WRX, USGX (Joint tape and compound, Item 5, optional for use with Type USGX).

USG MEXICO S A DE C V — Type AR, C, IP-AR, IP-X1, IP-X2, IPC-AR, SCX, SHX, WRC or WRX.

4A. **Gypsum Board*** — (As alternate to Item 4) - Nom 5/8 in. thick gypsum panels with beveled, square or tapered edges, applied vertically or horizontally. Vertical joints centered over studs and staggered one stud cavity on opposite sides of studs. Horizontal edge joints and horizontal butt joints on opposite sides of studs need not be staggered or backed by steel framing. Panels attached to steel studs and floor runner with 1 in. long Type S steel screws spaced 8 in. OC when applied horizontally, or 8 in. OC along vertical and bottom edges and 12 in. OC in the field when panels are applied vertically. When used in widths other than 48 in., gypsum panels to be installed horizontally.

CERTAINTED GYPSUM INC — Type X, Type C, Type EGRG/ GlasRoc.

CGC INC — Types AR, C, IP-AR, IP-X1, IP-X2, IPC-AR, SCX, SHX, WRC or WRX.

CONTINENTAL BUILDING PRODUCTS OPERATING CO, L L C — Type LGFC6A, LGFC-C/A

GEORGIA-PACIFIC GYPSUM L L C — Types DAP, DAPC, DGG, DS.

THAI GYPSUM PRODUCTS PCL — Type X, Type C.

UNITED STATES GYPSUM CO — Type AR, C, FRX-G, IP-AR, IP-X1, IP-X2, IPC-AR, SCX, SHX, WRC, WRX, , USGX (Joint tape and compound, Item 5, optional for use with Type USGX).

USG MEXICO S A DE C V — Type AR, C, IP-AR, IP-X1, IP-X2, IPC-AR, SCX, SHX, WRC or WRX.

4B. **Gypsum Board*** — (As an alternate to Items 4 or 4A) — Nom 3/4 in. thick, 4 ft wide, installed as described in Item 4A with screw length increased to 1-1/4 in.

CGC INC — Types AR, IP-AR.

UNITED STATES GYPSUM CO — Types AR, IP-AR.

USG MEXICO S A DE C V — Types AR, IP-AR.

4C. **Gypsum Board*** — As an alternate to Items 4, 4A, and 4B - Nom. 5/8 in. thick gypsum panels, with square edges, applied horizontally. Gypsum panels fastened to framing with 1 in. long bugle head steel screws spaced a max 8 in. OC, with last 2 screws 3/4 in. and 4 in. from each edge of board. Horizontal joints need not be backed by steel framing. Horizontal edge joints and horizontal butt joints on opposite sides of studs on interior walls need not be staggered or backed by steel framing.

GEORGIA-PACIFIC GYPSUM L L C — GreenGlass Type X.

4D. **Gypsum Board*** — As an alternate to Items 4, 4A, 4B, and 4C - Nom. 5/8 in. thick gypsum panels applied vertically or horizontally. Horizontal edge joints and horizontal butt joints on opposite sides of studs need not be staggered or backed by steel framing. Gypsum panels fastened to framing with 1 in. long Type S steel screws 8 in. OC along vertical edges and 12 in. OC in the field when panels are applied vertically, or 1-1/2 in. from board edges, 3 in. from board edge and every 8 in. OC in the field when applied horizontally. Screws spaced a max 12 in. along the top and bottom edges of the wall.

NATIONAL GYPSUM CO — Types eXP-C, FSK, FSK-C, FSK-G, FSL, FSW-C, FSW-G, FSW, FSW-3, FSW-5, FSW-6, FSW-8, FSMR-C.

4E. **Gypsum Board*** — (As an alternate to Items 4 through 4D) - Installed as described in Item 4. 5/8 in. thick, 4 ft. wide, paper surfaced, applied vertically only and fastened to the studs and plates with 1 in. long, Type S steel screws spaced, 8 in. OC. Not to be used with item 6.

NATIONAL GYPSUM CO — SoundBreak XP Type X Gypsum Board

4F. **Gypsum Board*** — (Not Shown) - (As an alternate to Item 4 when used as the base layer on one or both sides of wall. For direct attachment only to steel studs Item 2C) - Nom 5/8 in. thick lead backed gypsum panels with beveled, square or tapered edges, applied vertically. Vertical joints centered over studs and staggered min 1 stud cavity on opposite sides of studs. Gypsum board secured to studs with 1-1/4 in. long Type S-12 steel screws spaced 8 in. OC at perimeter and 12 in. OC in the field.

RAY-BAR ENGINEERING CORP — Type RB-LBG

4G. **Gypsum Board*** — (As an alternate to Items 4 through 4F) — For use with Items 1D and 2D only, 5/8 in. thick, 4 ft wide, attached to steel studs and floor and ceiling track with 1 in. long, Type S steel screws spaced 8 in. OC. along edges of board and 12 in. OC in the field of the board. Joints oriented vertically and staggered on opposite sides of the assembly.

CONTINENTAL BUILDING PRODUCTS OPERATING CO, L L C — Type LGFC6A, LGFC-C/A

NATIONAL GYPSUM CO — Types FSW

UNITED STATES GYPSUM CO — Type SCX

4H. **Gypsum Board*** — (As an alternate to Items 4 through 4G) — Nominal 5/8 in. thick, 4 ft wide panels, applied

vertically and secured as described in Item 4.

PABCO BUILDING PRODUCTS L L C, DBA PABCO GYPSUM — Type QuietRock ES.

4I. **Gypsum Board*** — (As an alternate to Items 4 through 4F) — For use with Items 1E and 2E only, 5/8 in. thick, 4 ft wide, attached to steel studs and floor and ceiling track with 1 in. long, Type S steel screws spaced 8 in. OC. along edges of board and 12 in. OC in the field of the board. Joints oriented vertically and staggered on opposite sides of the assembly.

UNITED STATES GYPSUM CO — Type SCX

4J. **Gypsum Board*** — (Not Shown) - (As an alternate to Item 4 when used as the base layer on one or both sides of wall. For direct attachment only to steel studs Item 2C) - Nom 5/8 in. thick lead backed gypsum panels with beveled, square or tapered edges, applied vertically. Vertical joints centered over studs and staggered min 1 stud cavity on opposite sides of studs. Gypsum board secured to studs with 1-1/4 in. long Type S-12 steel screws spaced 8 in. OC at perimeter and 12 in. OC in the field. To be used with Lead Batten Strips (see Item 9A) or Lead Discs (see Item 10A).

MAYCO INDUSTRIES INC — Type X-Ray Shielded Gypsum

4K. **Gypsum Board*** — (As an alternate to Item 4 and 4A, not for use with Items 1D, 1E, 2D and 2E) - Nom. 5/8 in. thick gypsum panels with beveled, square or tapered edges installed as described in Item 4 and 4A.

CGC INC — Type ULX

UNITED STATES GYPSUM CO — Type ULX

USG MEXICO S A DE C V — Type ULX

4L. **Gypsum Board*** — (Not Shown) - (As an alternate to Item 4 when used as the base layer on one or both sides of wall. For direct attachment only to steel studs Item 2C). Nom 5/8 in. thick lead backed gypsum panels with beveled, square or tapered edges, applied vertically. Vertical joints centered over studs and staggered min 1 stud cavity on opposite sides of studs. Wallboard secured to studs with 1-1/4 in. long Type S-12 steel screws gypsum panel steel screws spaced 8 in. OC at perimeter and 12 in. OC in the field. Lead batten strips required behind vertical joints of lead backed gypsum wallboard and optional at remaining stud locations. Lead batten strips, min 2 in. wide, max 8 ft long with a max thickness of 0.14 in. placed on the face of studs and attached to the stud with construction adhesive and two 1 in. long Type S-12 pan head steel screws, one at the top of the strip and one at the bottom of the strip. Lead discs, nominal 3/8 in. diam by max 0.085 in. thick. Compression fitted or adhered over the screw heads. Lead batten strips and discs to have a purity of 99.9% meeting the Federal specification QQ-L-201f, Grade "C".

RADIATION PROTECTION PRODUCTS INC — Type RPP - Lead Lined Drywall

4M. **Gypsum Board*** — (For use with Item 8) - 5/8 in. thick, 4 ft wide, applied vertically over Mineral and Fiber Board (Item 8) with vertical joints located anywhere over stud cavities. Secured to mineral and fiber boards with 1-1/2 in. Type G Screws spaced 8 in. OC along edges of each vertical joint and 12 in. OC in intermediate field of the Mineral and Fiber Board (Item 8). Secured to outermost studs and floor and ceiling runners with 2 in. long Type S screws spaced 8 in. OC. Gypsum Board joints covered with paper tape and joint compound. Screw heads covered with joint compound.

AMERICAN GYPSUM CO — Type AG-C

CERTAINTED GYPSUM INC — Type FRPC, Type C

CGC INC — Types C, IP-X2, IPC-AR

CONTINENTAL BUILDING PRODUCTS OPERATING CO, L L C — Type LGFC-C/A

GEORGIA-PACIFIC GYPSUM L L C — Types 5, DAPC, TG-C

NATIONAL GYPSUM CO — Types eXP-C, FSK-C, FSW-C

PABCO BUILDING PRODUCTS L L C, DBA PABCO GYPSUM — Type PG-C.

PANEL REY S A — Type PRC

THAI GYPSUM PRODUCTS PCL — Type C

UNITED STATES GYPSUM CO — Types C, IP-X2, IPC-AR

USG MEXICO S A DE C V — Types C, IP-X2, IPC-AR

4N. Wall and Partition Facings and Accessories* — (As an alternate to Item 4) — Nominal 5/8 in. thick, 4 ft wide panels, applied vertically and secured as described in Item 4.

PABCO BUILDING PRODUCTS L L C, DBA PABCO GYPSUM — Type QuietRock 527.

4O. Gypsum Board* — As an alternate to Items 4, 4A, 4B, and 4C - Two layers Nom. 5/16 in. thick gypsum panels applied vertically or horizontally. Horizontal edge joints and horizontal butt joints on opposite sides of studs need not be staggered or backed by steel framing. Horizontal joints on the same side need not be staggered. When applied horizontally, both layers of gypsum board fastened to each side of framing with 1 in. long Type S steel screws spaced 8 in. OC and staggered 4 in. OC between layers. When applied vertically, both layers of gypsum board fastened to each side of framing with 1 in. long Type S steel screws spaced 8 in. OC along vertical edges and 12 in. OC in the field, staggered 4 in. OC between layers. Screws spaced a max 12 in. along the top and bottom edges of the wall.

NATIONAL GYPSUM CO — Type FSW.

5. Joint Tape and Compound — Vinyl, dry or premixed joint compound, applied in two coats to joints and screw heads; paper tape, 2 in. wide, embedded in first layer of compound over all joints. As an alternate, nominal 3/32 in. thick gypsum veneer plaster may be applied to the entire surface of Classified veneer baseboard. Joints reinforced. Paper tape and joint compound may be omitted when gypsum boards are supplied with square edges.

6. Resilient Channel — (Optional-Not Shown) — 25 MSG galv steel resilient channels spaced vertically max 24 in. OC, flange portion attached to each intersecting stud with 1/2 in. long type S-12 pan head steel screws. May not be used with Item 4F or 4J.

6A. Steel Framing Members (Not Shown)* — As an alternate to Item 6, furring channels and resilient sound isolation clip as described below:

a. **Furring Channels** — Formed of No. 25 MSG galv steel. 2-9/16 in. or 2-23/32 in. wide by 7/8 in. deep, spaced 24 in. OC perpendicular to studs. Channels secured to studs as described in Item b. Ends of adjoining channels are overlapped 6 in. and tied together with double strand of No. 18 SWG galv steel wire near each end of overlap. As an alternate, ends of adjoining channels may be overlapped 6 in. and secured together with two self-tapping No. 6 framing screws, min 7/16 in. long at the midpoint of the overlap, with one screw on each flange of the channel.

b. **Framing Members*** — Used to attach furring channels (Item a) to studs (Item 2). Clips spaced 48 in. OC., and secured to studs with 1-5/8 in. wafer or hex head Type S steel screw through the center grommet. Furring channels are friction fitted into clips. RSIC-1 clip for use with 2-9/16 in. wide furring channels. RSIC-1 (2.75) clip for use with 2-23/32 in. wide furring channels.

PAC INTERNATIONAL INC — Types RSIC-1, RSIC-1 (2.75).

6B. Framing Members* — (Not Shown) — (Optional on one or both sides) — As an alternate to Item 6, furring channel and Steel Framing Members as described below:

a. **Furring Channels** — Formed of No. 25 MSG galv steel. 2-3/8 in. wide by 7/8 in. deep, spaced max. 24 in. OC perpendicular to studs. Channels secured to studs as described in Item b. Gypsum board attached to furring channels as described in Item 4.

b. **Steel Framing Members*** — Used to attach furring channels (Item 6Ba) to studs (Item 2). Clips spaced max. 48 in. OC. GENIECLIPS secured to studs with No. 8 x 1-1/2 in. minimum self-drilling, S-12 steel screw through the center grommet. Furring channels are friction fitted into clips.

PLITEQ INC — Type Genie Clip

6C. Steel Framing Members — (Optional, Not Shown)* - Furring channels and resilient sound isolation clip as described below:

a. **Furring Channels** — Formed of No. 25 MSG galv steel. Spaced 24 in. OC perpendicular to studs. Channels secured to studs as described in Item b. Ends of adjoining channels overlapped 6

in. and secured together with four self-tapping No. 8x1/2 Self Drilling screws (2 per side 1 in. and 4 in. from overlap edge). Gypsum board attached to furring channels as described in Item 4. Side joint furring channels shall be attached to studs with RESILMOUNT Sound Isolation Clips - Type A237R located approximately 2 in. from each end of length of channel. Both Gypsum Boards at side joints fastened into channel with screws spaced 8 in. OC, approximately 1/2 in. from joint edge.

b. **Steel Framing Members*** — Resilient sound isolation clip used to attach furring channels (Item 6Ca) to studs. Clips spaced 24 in. OC., and secured to studs with No. 10 x 2-1/2 in. coarse drywall screw through the center hole. Furring channels are friction fitted into clips.

STUDCO BUILDING SYSTEMS — RESILMOUNT Sound Isolation Clips - Type A237R

7. Wall and Partition Facings and Accessories* — (Optional, Not shown) — Nominal 1/2 in. thick, 4 ft wide panels, for optional use as an additional layer on one or both sides of the assembly. Panels attached in accordance with manufacturer's recommendations. When the QR-510 panel is installed between the steel framing and the UL Classified gypsum board, the required UL Classified gypsum board layer(s) is/are to be installed as indicated as to fastener type and spacing, except that the required fastener length shall be increased by a minimum of 1/2 in. Not evaluated or intended as a substitute for the required layer(s) of UL Classified Gypsum Board.

PABCO BUILDING PRODUCTS L L C, DBA PABCO GYPSUM — Type QuietRock QR-510.

8. Mineral and Fiber Board* — (Optional, Not shown) — For optional use as an additional layer on one side of wall. Nom 1/2 in. thick, 4 ft wide with long dimension parallel and centered over studs. Attached to studs and floor and ceiling runners with 1-5/8 in. long Type S steel screws, spaced 12 in. OC and 24 in. OC along all intermediate framing. The required UL Classified gypsum board layer (Item 4M) is to be installed over the Mineral and Fiber Boards. Batts and Blankets, Item 3D, and Adhesive, Item 11, are required.

HOMASOTE CO — Homasote Type 440-32

9. Lead Batten Strips — (Not Shown, For Use With Item 4E) - Lead batten strips, min 1-1/2 in. wide, max 10 ft long with a max thickness of 0.125 in. Strips placed on the interior face of studs and attached from the exterior face of the stud with two 1 in. long Type S-12 pan head steel screws, one at the top of the strip and one at the bottom of the strip. Lead batten strips to have a purity of 99.9% meeting the Federal specification QQ-L-201f, Grade "C". Lead batten strips required behind vertical joints of lead backed gypsum board (Item 4E) and optional at remaining stud locations. Required behind vertical joints.

9A. Lead Batten Strips — (Not Shown, for use with Item 4J) Lead batten strips, 2 in. wide, max 10 ft long with a max thickness of 0.140 in. Strips placed on the face of studs and attached to the stud with two min. 1 in. long min. Type S-8 pan head steel screws, one at the top of the strip and one at the bottom of the strip or with one min. 1 in. long min. Type S-8 pan head steel screw at the top of the strip. Lead batten strips to have a purity of 99.5% meeting the Federal specification QQ-L-201f, Grades "B, C or D". Lead batten strips required behind vertical joints of lead backed gypsum wallboard (Item 4J) and optional at remaining stud locations.

10. Lead Discs or Tabs — (Not Shown, For Use With Item 4E) - Used in lieu of or in addition to the lead batten strips (Item 8) or optional at other locations - Max 3/4 in. diam by max 0.125 in. thick lead discs compression fitted or adhered over steel screw heads or max 1/2 in. by 1-1/4 in. by max 0.125 in. thick lead tabs placed on gypsum boards (Item 4E) underneath screw locations prior to the installation of the screws. Lead discs or tabs to have a purity of 99.9% meeting the Federal specification QQ-L-201f, Grade "C".

10A. Lead Discs — (Not Shown, for use with Item 4J) Max 5/16 in. diam by max 0.140 in. thick lead discs compression fitted or adhered over steel screw heads. Lead discs to have a purity of 99.5% meeting the Federal Specification QQ-L-201f, Grades "B, C or D".

11. Adhesive — Not Shown - (For use with Item 8) - Construction grade adhesive applied in vertical, serpentine, nominal 3/8 in. wide beads down the length of both vertical edges of Mineral and Fiber Board (Item 8).

12. Wall and Partition Facings and Accessories* — (Optional, Not Shown) — For use with Items 1 to 1I, Items 2 to 2J, Item 3, Items 4 to 4I, Item 5 and Item 6. For maximum fire rating of 1 hour. On one side of the wall, over the first layer of Gypsum Board (Item 4 to Item 4I), install RefleXor membrane with the gold side facing outwards. Membrane installed with T50 staples spaced 12 inches on center in both directions as per manufacturer's instructions, seams in membrane to be overlapped by 2 inches. When RefleXor membrane is used an additional layer of Gypsum Board that is identical to the one used in the first layer and as specified in Item 4 to Item 4I shall be installed over the membrane. The additional layer of Gypsum Board to be installed through the membrane to the stud as specified in Item 4 to Item 4I except the fastener length shall be increased by a minimum of 5/8 inch. Install Batts and Blankets in the stud cavity as per Item 3. On the other side of the wall, prior to the installation of the Gypsum Board, install Resilient Channels as per Item 6. Over the Resilient Channels install 3/4 inch thick SONOpan panel secured to the Resilient Channels with drywall screws and washers spaced at 16 in. OC on the perimeter of the panel and 8 in. OC in the field of the panel. Over the SONOpan panel install the same Gypsum Board as specified in Item 4 to Item 4I with the fastener length increased by minimum 3/4 inch. Not evaluated or intended as a substitute for the required layer(s) of UL Classified Gypsum Board.

MSL — RefleXor membrane, SONOpan panel.

*** Indicates such products shall bear the UL or cUL Certification Mark for jurisdictions employing the UL or cUL Certification (such as Canada), respectively.**

[Last Updated](#) on 2015-04-08

[Questions?](#)

[Print this page](#)

[Terms of Use](#)

[Page Top](#)

© 2015 UL LLC

When the UL Leaf Mark is on the product, or when the word "Environment" is included in the UL Mark, please search the [UL Environment database](#) for additional information regarding this product's certification.

The appearance of a company's name or product in this database does not in itself assure that products so identified have been manufactured under UL's Follow-Up Service. Only those products bearing the UL Mark should be considered to be Certified and covered under UL's Follow-Up Service. Always look for the Mark on the product.

UL permits the reproduction of the material contained in the Online Certification Directory subject to the following conditions: 1. The Guide Information, Assemblies, Constructions, Designs, Systems, and/or Certifications (files) must be presented in their entirety and in a non-misleading manner, without any manipulation of the data (or drawings). 2. The statement "Reprinted from the Online Certifications Directory with permission from UL" must appear adjacent to the extracted material. In addition, the reprinted material must include a copyright notice in the following format: "© 2015 UL LLC".

SECTION 09 22 20 – ACOUSTICAL INSULATION

PART 1 - GENERAL

1.1 SUMMARY

- A. Provide materials, fabrications and installation of acoustical insulation and associated accessories.

1.2 SUBMITTALS

- A. Comply with requirements of Section 013300 – Submittal Procedures.
- B. Manufacturer's product data and literature describing each type of insulation.

1.3 QUALITY ASSURANCE

- A. Regulatory Requirements:
 - 1. Insulation shall be certified by the manufacturer to comply with California standards for insulating materials.
 - 2. Insulating materials shall be installed in compliance with Flame Spread Rating and Smoke Density requirements of IBC.
- B. Fire Performance Characteristics: Provide insulation materials whose fire performance characteristics have been determined per the ASTM test method indicated below. Identify products with appropriate markings of applicable testing and inspecting organization.
 - 1. Surface Burning Characteristic: ASTM E84
 - 2. Fire Resistance Ratings: ASTM E119
 - 3. Combustion Characteristics: ASTM E136
- C. Single Source Responsibility for Insulation Products: Obtain each type of building insulation from a single source with resources to provide products of consistent quality in appearance and physical properties without delaying progress of the Work.

1.5 DELIVERY, STORAGE, AND HANDLING

- A. Comply with requirements of Section 016000 – Product Requirements.
- B. Deliver and store packaged materials in original containers bearing identification of manufacturer's name, thermal resistance rating, and fiber materials. Maintain seals unbroken and labels intact until time of use.
- C. Keep materials dry by storing off ground under watertight covers.

1.6 PROJECT CONDITIONS

- A. Comply with requirements of Section 013100 – Project Management and Coordination.
- B. Do not install insulation until construction has progressed to a point that inclement weather will not damage or wet insulation.

PART 2 - PRODUCTS

2.1 MATERIALS

- A. Acoustical Insulation: Unfaced, friction-fit, flexible sound attenuation batt of fiberglass.
 - 1. Provide thermal resistance rating of R-13, Unless otherwise shown.
 - 2. Comply with requirements of ASTM C 665-84, Type I.
 - 3. Manufacturers: Owens-Corning Fiberglass Corp. "Unfaced Fiberglass Insulation," Schuller- "Unfaced Fiberglass Insulation" or Certainteed Products Corp. "Rigid Fit Unfaced Fiberglass Insulation."

2.2 ACCESSORIES

- A. Electrical Box Acoustical Sealer: Resilient sealer pads; "Electrical Box Pads" manufactured by 3M, or approved equivalent.
- B. Insulation Support: String wire, staples, nails as required.
- C. Stick Fasteners: Rust-resistant metal fasteners and washers adhesively applied to substrate. Stic-Klip Mfg. Co. "Type A or N" with Speed Washers or Miracle Adhesives Corp. "Stuk-Ups, Prong or Spindle and Washer".
- D. Adhesive for Stick Fasteners: Type as recommended by fastener manufacturer.
- E. Sealing Tape: Type as recommended by the thermal insulation manufacturer.

PART 3 - EXECUTION

3.1 EXAMINATION

- A. Examine areas to receive insulation for conditions that will adversely affect installation and performance.
- B. Do not start work until defects have been corrected.
- C. Coordination: Ensure that all work that will be concealed by the work of this Section, such as electrical and plumbing work, that require inspection, have received all required inspections, and been accepted by the inspecting authority.

3.2 INSTALLATION OF INSULATION

A. General Requirements:

1. Comply with insulation manufacturer's instructions applicable to products and application indicated. If printed instructions are not available or do not apply to project conditions, consult manufacturer's technical representative for specific recommendations before proceeding with installation of insulation.
2. Install insulation to fit snugly between framing members and around pipes, conduits, and outlet boxes as necessary to maintain integrity of insulation.
3. Provide means to prevent displacement where required.

B. Acoustical Insulation:

1. Fill spaces between studs with acoustical insulation.
2. Cover rear surface of all recessed mechanical and electrical outlet boxes with outlet box acoustical isolation pad.

3.3 DEFECTIVE WORK

- A. Remove any wet insulation or material deemed defective by the Architect, and replace with new material.
- B. Restore other work to original condition which was damaged by repair or replacement of defective insulation work.
- C. Remove damaged materials from project.

3.4 PROTECTION

- A. General: Protect installed insulation and vapor retarders from damage due to harmful weather exposures, physical abuse, and other causes.
- B. Provide temporary coverings or enclosures where insulation will be subject to abuse and cannot be concealed and protected by permanent construction immediately after installation.

END OF SECTION

SECTION 09 29 00 – GYPSUM BOARD

PART 1 - GENERAL

1.1 SUMMARY

- A. Work Included: Provide and Install gypsum board panels and cementitious panels, complete as shown, including finishing materials and accessories.
1. Interior gypsum board walls, ceilings and soffits:
 - a. Fire/smoke-rated assemblies.
 - b. Acoustic assemblies.
 - c. Water-resistant assemblies.
 - d. Impact-resistant gypsum board wall assemblies.
 - e. General wall assemblies, including multi-layer assemblies to facilitate reveals and other decorative features.
 - f. Cementitious backer board for interior tile assemblies.
 2. Interior finishing materials and accessories:
 - a. Tapes, joint treatments, and coating materials to prepare wall surfaces for painting by others.
 - b. Corner beads, reveals, and other trims.
 - c. Neoprene tapes for sealing to work by others.
 - d. Fasteners, adhesives and sealants.
 - e. Special trim and accessories.
 3. Projectile Resistant Backing: ballistic-proof fiberglass backing for Pharmacy wall assemblies and where shown on Drawings.
- B. Work Specified Elsewhere:
1. Section 092216 – Non-Structural Metal Framing.
 4. Section 093000 – Tile.
 5. Section 072400 – Exterior Insulation and Finish System (EIFS).
 6. Section 099123 – Interior Painting.

1.2 SUBMITTALS

- A. Comply with requirements of Section 013300 – Submittal Procedures.

- B. Provide manufacturers' data describing products and installations.

1.3 QUALITY ASSURANCE

- A. Comply with the latest edition of the following standards:
 - 1. American Society for Testing and Materials ASTM C 840, Standard Specification for Application and Finishing of Gypsum Board.
 - 2. Gypsum Association (GA) File Numbers in GA-600 Fire Resistance Design Manual.
- B. Fire rated gypsum board systems shall satisfy minimum fire ratings as noted and shall conform to methods approved by applicable Building Code.
- C. Tolerances of Installed Trims and Accessories:
 - 1. Horizontal Variation from Level: 1/8-inch in 12 feet.
 - 2. Vertical Variation from Plumb: 1/8-inch in 8 feet.

1.5 DELIVERY, STORAGE AND HANDLING

- A. Comply with requirements of Section 016000 – Product Requirements.
- B. Deliver materials to the project site with manufacturers' labels intact and legible.
- C. Keep materials dry by storing inside building and fully protect from weather.
- D. Stack gypsum board neatly and flat, with care to avoid damage to edges, ends and surfaces.

1.6 PROJECT CONDITIONS

- A. Environmental Requirements: Establish and maintain application and finishing environment in accordance with ASTM C 840.
- B. Provide adequate ventilation to eliminate excessive moisture within building during this work.

PART 2 - PRODUCTS

2.1 MATERIALS - INTERIOR APPLICATIONS

- A. Interior Gypsum Board: Use 5/8-inch-thick, Type 'X' gypsum board throughout, unless otherwise noted.
 - 1. Typical Finish Board, use throughout unless otherwise noted. ASTM C 36, Type X; tapered, or beveled taper edge, 48 inches wide by maximum length to minimize number of joints.

2. Water-Resistant Gypsum Backing Board: Provide USG's Fiberock Brand "Aqua-Tough"; Georgia-Pacific (GP) "DensShield Tile Guard"; Glass-Mat, Water-Resistant Backing Board through core gypsum board panels per ASTM C 1178, Type FRX-G; tapered, or beveled taper edge, 48 inches wide by maximum length to minimize number of joints.
 - a. Locations: Use at high humidity/moisture locations, including Central Processing (Sterile Processing and Decontamination Rooms), HSKP rooms, Kitchen and Servery areas.
3. High Abuse, Impact Resistant Board: Provide National Gypsum Hi-Abuse Kal-Kore, USG's Fiberock Brand "Aqua-Tough". 5/8-inch-thick, ASTM C1278, Type X; fiber reinforced gypsum panels; tapered, or beveled taper edge, 48 inches wide by maximum length to minimize number of joints.
 - a. Gypsum core wall panel with additives to enhance surface indentation resistance, and impact resistance of the core and surface with abrasion-resistant paper on front and long edges with heavy liner paper bonded to the back side and conforming to ASTM C36.
 - b. Impact Resistance: No failure after 100 impacts when tested in accordance with ASTM E695, modified.
 - c. Indentation Resistance: Not less than the following loads to produce the indicated depth of the surface indentation when tested in accordance with ASTM D1037, modified:
 - 1) 0.100-inch at 260 pounds.
 - 2) 0.200-inch at 524 pounds.
 - d. Locations: Typical all corridors from finished floor to 48 inches above finished floor.
4. 1/4-inch Flexible Type: Provide board manufactured to bend to fit tighter radii than specified regular-type gypsum board.
 - a. Provide only at non-rated curved layouts that exceed maximum allowable bending radii of specified standard thickness gypsum board.
 - b. Thickness: 1/4 inch. Provide minimum 2 layer application with staggered joints.
 - c. Long Edges: Tapered.
5. Early-install/Concealed locations (Contractor Option): Provide Georgia Pacific DensGlass Ultra Shaft and DensAmor Plus in conformance with ASTM D 3273; products inherently mold and mildew resistant for use in shaftwalls, concealed locations above finished ceilings, internal layers of multi-layer assemblies and other locations approved by Architect to allow installation before the building enclosure is 100-percent complete.

- a. Use at Shaft-side of shaft assemblies and any location where early install is required prior to closing in of the building.
- B. Cementitious Backer Board: Per ANSI A108.1; Provide Custom Building Product's "Wonderboard"; USG's "Durock Cement Board". Panels of high-density portland cement surface coating on both faces of lightweight portland cement and expanded ceramic aggregate core, nominal 5/8-inch-thick and 3.2 to 3.8 pounds per square foot.
1. General: Provide for tile assemblies specified in Section 09 30 00 – Tiling. (Typical at all toilets/restrooms) At fire-rated wall assemblies and inside faces of exterior walls, apply over gypsum board base layer.
- ~~C. Acoustically enhanced Gypsum Wallboard Composite:~~
- ~~a. Two-ply high density, mold resistant, paper faced gypsum wallboard laminated together with viscoelastic dampening polymer.~~
 - ~~b. Composite Thickness 5/8 inches~~
 - ~~c. Fire resistance, Type X gypsum core~~
 - ~~d. Base Product: Quite Rock-ES by PABCO Gypsum OR Sound Break XP by National Gypsum Company~~
- D. Interior Joint Finishing Materials:
1. General: Comply with ASTM C 475/C 475M.
 2. Joint Tape:
 - a. Interior Gypsum Wallboard: Paper.
 - b. Tile Backing Panels: As recommended by panel manufacturer.
 3. Joint Compound for Interior Gypsum Wallboard: For each coat use formulation that is compatible with other compounds applied on previous or for successive coats.
 - a. Prefilling: At open joints, beveled panel edges, and damaged surface areas, use setting-type taping compound.
 - b. Embedding and First Coat: For embedding tape and first coat on joints, fasteners, and trim flanges, use setting-type taping or drying-type, all-purpose compound as recommended by the manufacturer to obtain best results from actual project conditions.
 - 1) Use setting-type compound for installing paper-faced metal trim accessories.
 - c. Fill Coat: For second coat, use drying-type, all-purpose compound.
 - d. Finish Coat: For third coat, use drying-type, all-purpose compound.

- e. Skim Coat: For final coat of Level 5 finish, use drying-type, all-purpose compound.
4. Joint Compound for Tile Backing Panels:
- a. Water-Resistant Gypsum Backing Board: Use setting-type taping compound and setting-type, sandable topping compound.
 - b. Glass-Mat, Water-Resistant Backing Panel: As recommended by backing panel manufacturer.
 - c. Cementitious Backer Units: As recommended by backer unit manufacturer.
- E. Fasteners:
- 1. Screws: ASTM C 954 or ASTM C 1002 self-drilling and self-tapping steel screws with double-lead thread design as approved by system manufacturer for standard and heavier gauge load bearing steel framing.
 - 2. Nails: ASTM C 514, annular ring type as approved by system manufacturer.
 - 3. Staples: Galvanized, as recommended to approved accessory manufacturer.
- F. Metal Backing: Refer to Section 092216 – Non-Structural Metal Framing.
- G. Metal Accessories: ASTM C 1047 Electro-galvanized steel corner beads and trim (casing beads) formed for application of joint cement and manufactured specifically for gypsum board construction, minimum base steel 0.014 inch thick.
- H. Special Trims and Accessories:
- 1. General: Provide extruded aluminum trims and accessories in conforming to profiles and shapes as shown on Drawings and as specified.
 - a. Provide double-layer gypsum board assemblies at locations shown on Drawings to receive recessed reveal trims.
 - b. Material: Extruded aluminum alloy 6063 T5.
 - c. Manufacturer: Provide products manufactured by Gordon, Fry Reglet Company, Flannery Company, or equal.
 - a. Accessories: For each trim profile noted below, provide factory fabricated where required by layouts shown on Drawings, including:
 - 1) Mitered assemblies for "T-intersections" and "X-intersections".

- 2) Finished end caps.
2. Partition "End Cap" Trims: Provide for providing finished ends to gypsum board walls including chemical conversion coating. Typical where gypsum board walls butt mullions of window or window wall assemblies, allowing attachment of partition cap to mullion prior to construction of gypsum board wall.
 - a. Overall Width: Provide width matched to partition assembly, including:
 - 1) 4-inch stud walls with 5/8-inch gypsum board each side.
 - 2) 6-inch stud walls with 5/8-inch gypsum board each side.
 - b. Tape/screw Flanges: Nominal 7/8-inch.
 - c. Manufacturer: Provide "910 Series" Final Forms by Gordon or equivalent products manufactured by Fry Reglet Company, Flannery Company, or equal.
3. Reveal "Top Track" Trim: Provide for top of wall or partial height partition top cap termination where shown on Drawings.
 - a. Reveal Depth: Nominal 5/8-inch for use with 5/8-inch gypsum board panels.
 - b. Reveal Width: As shown on Drawings.
 - c. Overall Width: Provide width matched to partition assembly, including:
 - 1) 4-inch stud walls with 5/8-inch gypsum board each side.
 - 2) 6-inch stud walls with 5/8-inch gypsum board each side.
 - d. Tape/screw Flanges: Nominal 7/8-inch.
 - e. Manufacturer: Provide "922 Series" Final Forms by Gordon or equivalent products manufactured by Fry Reglet Company, Flannery Company, or equal.
4. Reveal "Field" Trims: Provide for creating square-edged vertical and horizontal reveal lines in gypsum board wall assemblies where shown on Drawings.
 - a. Depth: Nominal 5/8-inch for use with 5/8-inch gypsum board panels.
 - b. Reveal Width: As shown on Drawings.
 - c. Tape/screw Flanges: Nominal 7/8-inch.
 - d. Manufacturer: Provide "500 Series" double-sided Final Forms

reveals by Gordon or equivalent products manufactured by Fry Reglet Company, Flannery Company, or equal.

5. Reveal "Edge" Trim: Provide for finished vertical and horizontal reveal edges at top and sides of gypsum board panels where shown on Drawings.
 - a. Reveal Depth: Nominal 5/8-inch for use with 5/8-inch gypsum board panels.
 - b. Reveal Width: As shown on Drawings.
 - c. Tape/screw Flanges: Nominal 7/8-inch.
 - d. Manufacturer: Provide "200 Series" Final Forms by Gordon or equivalent products manufactured by Fry Reglet Company, Flannery Company, or equal.
6. Reveal "Base" Trim: Provide for recessed base at bottom of gypsum board panels at floor where shown on Drawings.
 - a. Reveal Depth: Nominal 5/8-inch for use with 5/8-inch gypsum board panels.
 - b. Reveal Width: 4-inches.
 - c. Tape/screw Flanges: Nominal 7/8-inch.
 - d. Manufacturer: Provide "800 Series" Final Forms by Gordon or equivalent products manufactured by Fry Reglet Company, Flannery Company, or equal.
7. Special Fabrications: Provide factory fabricated mitered assemblies for "T-intersections" and "X-intersections" where shown on Drawings.
8. Finish: Special trims to be primed and painted to match adjacent wall surfaces as specified in Section 099123 – Interior Painting.
 - I. Adhesive for Laminating Board: As recommended by approved board manufacturer.
 - J. Acoustical Sealant: As specified in Section 079200 – Joint Sealants.
 - K. Electrical Box Sealer:
 - a. Non-rated Locations: As specified in Section 079200 – Joint Sealants.
 - b. Fire-rated Locations: As specified in Section 078413 – Penetration Firestopping.
 - L. Concealed, Non-Rated Access Panels: As specified in Section 08310 – Access Panels.

PART 3 - EXECUTION

3.1 EXAMINATION

- A. Inspect areas and surfaces scheduled to receive gypsum board and verify that:
 - 1. Support systems are in proper alignment, straight and true.
 - 2. Required blocking, bracing and backing members of support systems are installed.
- B. Do not start work until unsatisfactory conditions are corrected.

3.2 PREPARATION

- A. Coordinate details with other work supporting, adjoining, or fastening to gypsum board.

3.4 INSTALLATION - INTERIOR GYPSUM BOARD

- A. General Requirements:
 - 1. Apply and finish gypsum board in accordance with requirements of ASTM C 840 unless otherwise noted.
 - 2. Cut gypsum board by scoring and breaking or sawing from face side. Smooth all cut edges and ends of gypsum board where necessary, in order to obtain neat jointing.
 - 3. Scribe ceiling board neatly in casing bead where it meets surfaces in other planes.
 - 4. Apply first to the ceiling at right angles to framing members, then to walls. Use boards of maximum practical length so that a minimum number of end joints occur.
 - 5. Apply in either vertical or horizontal direction with ends and edges falling on framing members or other solid backing except where edge joints are at right angles to support. Bring ends and edges into contact with adjoining board, but do not force into place.
 - 6. Lay out joints at openings so that no end joint aligns with edges of opening unless control joints will be installed at these points.
 - a. All joints running parallel to framing shall be centered as near as possible on face of framing member.
 - b. Stagger end joints and arrange joints on opposite sides of partition to occur on different studs.
 - c. At external corners, butt and fit board to provide solid edge.
 - 7. Hold gypsum board nominal 1/4-inch above floor or curb typical.
 - 8. Where gypsum board is carried full height to structure above, provide

for deflection of structure by undercutting board nominal 3/8 inch and seal top edge of board to structure in continuous bead to form elastic closure.

9. Cut board to fit electrical outlets, pipes, or other items as required.
 - a. Cut gypsum board by scoring on face and back in outline before removal or by cutting with a saw or other suitable tool.
 - b. Smooth all cut out where necessary.
 10. After trim is applied and prior to decoration, correct surface damage and defects.
 11. Provide gypsum backer board gusset at double stud walls where studs are less than 3-5/8 inches thick.
 12. Fastening:
 - a. Attach board from center to edges and ends, pressing firmly against supports. Place fasteners approximately not more than 1 inch nor less than 3/8 inch from edges with heads just below gypsum board surfaces; but do not break paper.
 - b. Walls: Space screws maximum 12 inches on center for ceilings and maximum 16 inches on center for walls in field and along abutting edges.
 - c. Suspended Ceilings: Space screws maximum 12 inches on center in field and along abutting edges.
- B. Curved Surfaces:
1. Install panels horizontally (perpendicular to supports) and unbroken, to extent possible, across curved surface plus 12-inch-long straight sections at ends of curves and tangent to them.
 2. 1/4-inch Board Application: For double-layer construction, fasten base layer to studs with screws 16 inches o.c. Center gypsum board face layer over joints in base layer, and fasten to studs with screws spaced 12 inches o.c.
 - a. Continue double layer 1/4-inch board application to closest adjacent inside or outside corners. Do not "shim" double board to align with adjacent 5/8 thick gypsum board.
 3. Fire-rated Assemblies: Provide in strict conformance with referenced UL-listed assembly. Use on standard thickness type "X" board bent per manufacturer's written instructions.
- C. Joint Treatment:
1. Apply tape and cement to joints and corners in strict accordance with directions of gypsum board manufacturer.

2. Pre-fill V-grooves formed by the abutting beveled or rounded wrapped edges with joint compound as per manufacturing recommendations.
 3. Use tape and cement, allow to dry between coats. Use number of coats required by level of finish specified.
 4. Work final coat to smooth level plane surface.
 5. Protect external corners with metal corner beads unless otherwise noted.
 6. Treat fastening head dimples same as joints; tape may be omitted.
 7. Joints and fastening head dimples in backer board need only be treated as required to preserve fire rating.
 8. Seal joints shown on Drawings and where gypsum board meets dissimilar material with specified sealant. Tool to neat surface, ready for paint; remove excess material.
- D. Fire-Rated Conditions:
1. At penetrations of rated assemblies, preserve continuity of fire rating with firestopping systems as specified in Section 07840 – Firestopping and Smoke Seals.
 2. Where adjacent interior spaces have suspended ceilings of different heights, extend separating partition finish on both faces of studs to at least 3 inches above higher ceiling finish.
 3. Conform to applicable codes and authorities for requirements of taping and cementing joints and fastener heads.
- E. Sound Retardant Partitions:
1. Construct partitions in accordance with Drawings and as herein specified.
 2. Hold face layers and base layers 1/4 inch clear from abutting surfaces, floors, walls and overhead structure. Seal with specified sealant and tape. Tape not required at floors.
 3. Provide airtight closures at wall penetrations (outlet boxes, pipes, duct work and other items) by neatly cutting gypsum board to clear penetrations. Seal void with specified sealant and apply joint tape to both gypsum board and penetrating object.
 4. Seal airtight the backs and sides of electrical junction boxes with resilient sealer pads.
- F. Furring over Recessed Light Fixtures: At non-rated lighting fixtures, construct furring from gypsum board as indicated on Drawings.

- G. Water-Resistant Board: During board application, coat all cut edges with approved water resistant adhesive as recommended by manufacturer for the application.
- H. Enclosure System: Install in strict accordance with requirements of approved manufacturer's system using metal components, gypsum components, and other accessories as required.
- I. Cementitious Backer Board:
 - 1. General: Install cementitious backer board in strict conformance with the requirements of the tile assemblies specified in Section 093000 – Tile.
 - 2. Provide support systems so that all edges of cementitious backer boards are supported.
 - 3. Use only corrosion-resistant fasteners.

3.5 FINISHING INTERIOR GYPSUM BOARD ASSEMBLIES

- A. Levels of Gypsum Board Finish: Provide the following levels of gypsum board finish per USG "Gypsum Construction Handbook, Centennial Edition".
 - 1. Level 1: for ceiling plenum areas, concealed areas, and where indicated, unless a higher level of finish is required for fire-resistive-rated assemblies and sound-rated assemblies.
 - 2. Level 2: where water-resistant gypsum backing board panels form substrates for tile, and where indicated.
 - 3. Level 3: Not used.
 - 4. Level 4: Not used.
 - 5. **Level 5: Typical, for all gypsum board surfaces unless otherwise indicated.**
- B. Level 4 gypsum board finish: Embed tape in joint compound and apply three separate coats of joint compound over joints, angles, fastener heads, and accessories. Touch up and sand between coats and after last coat as needed to produce a surface free of visual defects and ready for decoration. Use the following joint compound combination:
 - 1. Embedding and First Coat: Ready-mixed, drying-type, all-purpose or taping compound.
 - 2. Fill (Second) Coat: Ready-mixed, drying-type, all-purpose or topping compound.
 - 3. Finish (Third) Coat: Ready-mixed, drying-type, all-purpose or topping compound.
- C. Where Level 5 gypsum board finish is indicated: apply joint compound combination specified for Level 4 plus a thin, uniform skim coat of joint compound over entire surface.

1. Use joint compound specified for the finish (third coat) or a product specially formulated for this purpose and acceptable to gypsum board manufacturer.
 2. Produce surfaces free of tool marks and ridges ready for decoration of type indicated.
- D. Where Level 2 gypsum board finish is indicated, apply joint specified for first coat in addition to embedding coat.
- E. Where Level 1 gypsum board finish is indicated, apply joint compound specified for embedding coat.
- F. Finish water-resistant gypsum backing board forming base for mortar-set ceramic tile to comply with ASTM C 840 and board manufacturer's directions for treatment of joints behind tile.
- G. Impact-Resistant Gypsum Board:
1. Construct partitions in accordance with Drawings and as herein specified.
 2. General: Install to a height of no less than 4 feet above finish floor at locations shown on Drawings.

3.6 PARTITION IDENTIFICATION

- A. Identify partitions indicated on drawings as having a required fire or smoke rating.
1. Follow guidelines set in Chapter 7 of International Building Code or as locally amended.
 2. Permanently identify with stenciling
 - a. Minimum 6 inches high letters with minimum ½ inch stroke.
 - b. Bottom of lettering to start at 6 inches above ceiling.
 - c. Stenciling to be 10 feet on center max.
 - d. Color : Red for 1-hr rated walls, Blue for 2-hr rated walls, Green for smoke partition walls.
 - e. Provide in a manner acceptable to authority having jurisdiction.

3.7 CLEANING AND PROTECTION

- A. Remedy any fastener popping or ridging.
- B. Promptly remove any residual joint compound from adjacent surfaces.
- C. Provide final protection and maintain conditions, in a manner suitable to Installer, that ensures gypsum board assemblies remain without damage or deterioration at time of Substantial Completion.

END OF SECTION

SECTION 09 30 00 - TILING

PART 1 - GENERAL

1.1 **RELATED DOCUMENTS**

- A. Drawings and general provisions of the Contract, including General and Supplementary Conditions and Division 1 Specification Sections, apply to this Section.

1.2 **SUMMARY**

- A. This Section includes the following:

- 1. Ceramic Tile.
- 2. Mosaic Tile.

- B. Related Sections include the following:

- 1. Division 9 Section "Gypsum Board " for cementitious backer board installed in gypsum wallboard assemblies.

1.3 **DEFINITIONS**

- A. Facial Dimension: Nominal tile size as defined in ANSI A137.1.
- B. Installation products: ANSI A118
- C. Installation procedures ANSI 108

1.4 **SUBMITTALS**

- A. Product Data: For each type of tile, mortar, grout, and other products specified.
- B. Shop Drawings: Show locations for each type of tile and tile pattern.
- C. Samples for Initial Selection: For each type of tile and grout indicated. Include Samples and accessories involving color selection.

1.5 **QUALITY ASSURANCE**

- A. Source Limitations for Tile: Obtain all tile of same type and color or finish from one source or producer.
 - 1. Obtain tile from same production run and of consistent quality in appearance and physical properties for each contiguous area.

1.6 **DELIVERY, STORAGE, AND HANDLING**

- A. Deliver and store packaged materials in original containers with seals unbroken and labels intact until time of use. Comply with requirement of ANSI A137.1 for labeling sealed tile packages.
- B. Store liquid latexes and emulsion adhesives in unopened containers and protected from freezing.

1.7 **PROJECT CONDITIONS**

- A. Environmental Limitations: Do not install tile until construction in spaces is completed and ambient temperature and humidity conditions are being maintained to comply with referenced standards and manufacturer's written instructions.

1.8 **EXTRA MATERIALS**

- A. Deliver extra materials to Owner. Furnish extra materials described below that match products installed, are packaged with protective covering for storage, and are identified with labels describing contents.
 - 1. Tile and Trim Units: Furnish quantity of full-size units equal to 3 percent of amount installed, for each type, composition, color, pattern, and size indicated.

PART 2 - PRODUCTS

2.1 **MANUFACTURERS**

- A. In other Part 2 articles where titles below introduce lists, the following requirements apply for product selection:
 - 1. Manufacturers: Subject to compliance with requirements, provide products by the following manufacturers specified: See finish schedule on drawings.

2.2 **PRODUCTS, GENERAL**

- A. ANSI Ceramic Tile Standard: Provide tile that complies with ANSI A137.1, "Specifications for Ceramic Tile," for types, compositions, and other characteristics indicated.
 - 1. Provide tile complying with Standard Grade requirements, unless otherwise indicated.
- B. Colors, Textures, and Patterns: Where manufacturer's standard products are indicated for tile, grout, and other products requiring selection of colors, surface textures, patterns, and other appearance characteristics, provide specific products or materials complying with the following requirements:
 - 1. Provide Architect's selections from manufacturer's full range of colors, textures, and patterns for products of type indicated. Several colors may be used as indicated on the drawings.

2.3 TILE PRODUCTS

A. Manufacturers:

1. Crosville, Inc.

B. Porcelain Floor Tile:

1. Composition: Porcelain stone collection - Notorious
2. Module Size: 12-inches x 24-inches
3. Nominal Thickness: 10.5mm
4. Color: NTR05.11224UPS – Leading Man
5. Coved Base Tile: 6" x 12" – NTR05.10612CBS Leading Man

C. Porcelain Floor Shower Tile:

1. Composition: Porcelain stone collection – Notorious
2. Module Size: 12-inches x 12-inches Mosaic
3. Nominal thickness: 10.5mm
4. Color: NTR05.11212MOS – Leading Man
5. Coved Base Tile: 6" x 12" – NTR05.10612CBS Leading Man

D. Porcelain Wall Tile:

1. Composition: Porcelain stone collection - Notorious
2. Module Size: 12-inches x 24-inches
3. Nominal Thickness: 10.5mm
4. Color: NTR01 – Femme Fatal, UPS

2.4 THRESHOLDS

A. General: Fabricate to sizes and profiles indicated or required to provide transition between adjacent floor finishes.

1. Bevel edges at 1:2 slope, aligning lower edge of bevel with adjacent floor finish. Limit height of bevel to 1/2 inch or less, and finish bevel to match face of threshold.
2. Solid Surface Thresholds: Provide solid surface thresholds fabricated by Corian.

2.5 WATERPROOFING:

A. Waterproof and Crack Isolation Membrane:

1. General: Sheet Membrane: ANSI A118.10; composite sheet membrane made from an alloy of non-plasticized Chlorinated Polyethylene (CPE) with non-woven fiber laminated to both sides.
2. Manufacturer: Noble Company, Product: NobleSeal TS.

B. Performance:

1. 1. Water Vapor Permeance: ASTM E96/E96M, Procedure E; maximum 0.15 perms (28.6 ng/Pa•s•m²).
2. Crack Isolation: "High performance" rating when tested to the "System Crack Resistance" portion of ANSI A118.12.

C. Accessories:

1. Bonding Mortar:
 - a. Latex-Portland Cement Mortar (Thin Set): ANSI A118.4.
2. Bonding Adhesive: Type recommended by sheet membrane manufacturer to suit application.
 - a. Basis of Design Product: NobleBond 21.
3. Mortar Bed:
 - a. Portland Cement Mortar (Thickset): ANSI A108.02.
4. Seam Sealant: Type recommended by sheet membrane manufacturer
 - a. Basis of Design Product: NobleWeld 150.
5. Perimeter Sealant: Type recommended by sheet membrane manufacturer

2.6 MORTAR MATERIALS - THICK SET BEDS

- A. Portland Cement Mortar; Thick-Set; Description: Site mix of Portland cement, sand and water as specified.
- B. Portland Cement With Latex Additive; Thick-Set:
 1. Portland Cement: ASTM C150, Type I, from one source only, non-staining and non-air-entraining.
 2. Supplemental cementitious materials derived from coal fired power plant wastes shall not have a mercury content >5.5ppb.
 3. Fly ash shall not be a byproduct of municipal solid waste incinerators
 4. Mortar Sand: ASTM C144, free of deleterious materials, well graded.
 5. Setting Bed Sand: ASTM C136, 100 percent passing No. 4 sieve.
 6. Latex Additive:
 - a. Description: Latex additive serving as replacement for gaging water, for use with site mixed portland cement mortar.
 - b. Quantity: As recommended by latex additive manufacturer to produce workable consistency.
 - c. Acceptable Products:
 - 1) CustomFloat Bedding Mortar mixed with Acrylic Mortar Admix 1:1 water by Custom Building Products.
 - 2) 3701 Mortar Admix by Laticrete.
 - 3) Planicrete 50 by Mapei.

2.7 MORTAR MATERIALS - THIN SET BEDS

- C. Portland Cement with Latex Additive; Thin-Set:
 1. Description: Latex additive and site mixed Portland Cement mortar. Complying with ANSI-A118.4.

2. Quantity: As recommended by latex additive manufacturer.
3. Acceptable Products:
 - a. CustomCrete Latex Mortar Admix with site mixed Mortar or CreteMix Mortar by Custom Building Products.
 - b. 4237 Latex Thin set Mortar Additive by Laticrete.
 - c. Keracrete System consisting of KER 303 Latex mixed with 1:1 sand/cement blend by Mapei.
4. For all glass tile and glass and stone mixed tile throughout use: Mapei Adesilex P10 bright white grout. Flatten trowel ridges prior to setting glass tiles.

2.8 EPOXY ADHESIVES

- D. Multi-component, factory prepared, 100 percent epoxy resin and hardener with sand or mineral filler material.
- E. Comply with ANSI A118.3 for thin-set applications for chemical resistant, water cleanable quarry tile installations.
- F. Acceptable Products:
 1. 100% Solids Epoxy Mortar by Custom Building Products.
 2. Latapoxy 300 Epoxy Adhesive by Laticrete.
 3. Kerapoxy 410 Chemical Resistant Epoxy Mortar by Mapei.

2.9 GROUT

- G. Epoxy Grout for Floor Tile:
 1. Multi-component, factory prepared, 100 percent epoxy resin and hardener with sand or mineral filler material.
 2. Comply with ANSI A118.3.
 3. Color: To be selected.
 4. Acceptable Products:
 - a. Kerapoxy Chemical Resistant Grout by Mapei.
- H. Unsanded Latex – Modified Grout for Wall Tiles
 1. Description: Latex modified, factory blended. Mildew resistant, non-sanded consisting of Portland cement and additives: comply with ANSI A118.6
 2. Latex Additive: Type as recommended by latex mortar manufacturer.
 3. Color: To be selected
 4. Acceptable Products:
 - a. KER 800 polymer-modified unsanded grout by Mapei

2.11 ELASTOMERIC SEALANTS

- a. General: Provide manufacturer's standard chemically curing, elastomeric sealants of base polymer and characteristics required.
- b. Colors: Provide colors of exposed sealants to match colors of grout in tile adjoining sealed joints, unless otherwise indicated.

1) Products:

- a) Bostik; Chem-Calk 550.
- b) Mameco International, Inc.; Vulkem 245.
- c) Tremco, Inc.; THC-900.

2.12 TILE BACKER BOARD

- a. Moisture-resistant treated gypsum core, glass mats both sides, and vinyl, water barrier coating on finished side.
- b. Thickness: 5/8 IN.
- c. Mold-resistance score: 10 per ASTM D3273.
- d. Base Product: DensShield Tile Backer by Georgia Pacific.
- e. Include Level 5 finish at non-tiled portions.
- f. Optional Products:
 1. Fiberock Interior Panel, Aqua-Tough by USG.
 2. GlasRoc Tile Backer by Certainteed.
- g. Tile Backer Board wallboard scheduled in Fire Rated Walls:
 1. Approved fire-resistive products with comparable moisture-resistance.
 2. Base Product: DensShield Fireguard Tile Backer by Georgia Pacific.

2.13 MISCELLANEOUS MATERIALS

- h. Trowelable Underlayments and Patching Compounds: Latex-modified, portland cement-based formulation provided or approved by manufacturer of tile-setting materials for installations indicated.
- i. Tile Cleaner: A neutral cleaner capable of removing soil and residue without harming tile and grout surfaces, specifically approved for materials and installations indicated by tile and grout manufacturers.
- j. Grout Sealer: Manufacturer's standard product for sealing grout joints that does not change color or appearance of grout. Provide at all grout applications as required by grout manufacturer.
- k. Edge protection and transition: for finishing outside edges of tiled wall corners or transitions to another material. Typical at all tile applications.
 - 1) Schluter Rondec or Jolly as required. Choose from manufacturers full line of colors.

2.13 MIXING MORTARS AND GROUT

- a. Use urethane based grout for stone and glass mosaic tiles applications at walls conforming to ISO 13007 R2 and ISO 13007 RG Enzyme resistant formula, respectively.
- b. Mix mortars and grouts to comply with referenced standards and mortar and grout manufacturers' written instructions.
- c. Add materials, water, and additives in accurate proportions.
- d. Obtain and use type of mixing equipment, mixer speeds, mixing containers, mixing time, and other procedures to produce mortars and grouts of uniform quality with optimum performance characteristics for installations indicated.

PART 2 - EXECUTION**1. EXAMINATION**

- a. Examine substrates, areas, and conditions where tile will be installed, with Installer present, for compliance with requirements for installation tolerances and other conditions affecting performance of installed tile.
 - 1) Verify that substrates for setting tile are firm; dry; clean; free of oil, waxy films, and curing compounds; and within flatness tolerances required by referenced ANSI A108 Series of tile installation standards for installations indicated.

- 2) Verify that installation of grounds, anchors, recessed frames, electrical and mechanical units of work, and similar items located in or behind tile has been completed before installing tile.
 - 3) Verify that joints and cracks in tile substrates are coordinated with tile joint locations; if not coordinated, adjust joint locations in consultation with Architect.
 - b. Proceed with installation only after unsatisfactory conditions have been corrected.
2. PREPARATION
- a. Remove coatings, including curing compounds and other substances that contain soap, wax, oil, or silicone, that are incompatible with tile-setting materials.
 - b. Provide concrete substrates for tile floors installed with adhesives or thin-set mortar that comply with flatness tolerances specified in referenced ANSI A108 Series of tile installation standards.
 - 1) Fill cracks, holes, and depressions with trowelable leveling and patching compound according to tile-setting material manufacturer's written instructions. Use product specifically recommended by tile-setting material manufacturer.
 - 2) Remove protrusions, bumps, and ridges by sanding or grinding.
3. INSTALLATION, GENERAL
- a. ANSI Tile Installation Standards: Comply with parts of ANSI A108 Series "Specifications for Installation of Ceramic Tile" that apply to types of setting and grouting materials and to methods indicated in ceramic tile installation schedules.
 - b. TCA Installation Guidelines: TCA's "Handbook for Ceramic Tile Installation." Comply with TCA installation methods indicated in ceramic tile installation schedules.
 - c. Extend tile work into recesses and under or behind equipment and fixtures to form complete covering without interruptions, unless otherwise indicated. Terminate work neatly at obstructions, edges, and corners without disrupting pattern or joint alignments.
 - d. Accurately form intersections and returns. Perform cutting and drilling of tile without marring visible surfaces. Carefully grind cut edges of tile abutting trim, finish, or built-in items for straight aligned joints. Fit tile closely to electrical outlets, piping, fixtures, and other penetrations so plates, collars, or covers overlap tile.
 - e. Jointing Pattern: Lay tile in patterns as shown in construction documents. Align joints when adjoining tiles on floor, base, walls, and trim are same size. Lay out tile work and center tile fields in both directions in each space or on each wall area. Adjust to minimize tile cutting. Provide uniform joint widths, unless otherwise indicated.
 - f. Lay out tile wainscots to next full tile beyond dimensions indicated.
 - g. Use crack isolation mat where poured gypsum is used for leveling.
 - h. Grout tile to comply with requirements of the following tile installation standards: For ceramic tile grouts (sand-portland cement; dry-set, commercial portland cement; and latex-portland cement grouts), comply with ANSI A108.10. Epoxy/Resin-Based Grout: ISO 13007 RG 100%-solid epoxy grout, with high chemical, stain, and enzymatic.

4. WATERPROOFING INSTALLATION

- a. If membrane is not wide enough, seam by overlapping sheets minimum 2 inches (50 mm), shingle fashion in direction of water drainage. Seal joints watertight.
- b. Turn sheet membrane installed on floors up vertical surfaces minimum 18 inches (50 mm) higher than flood plane and bond to substrate.
 - 1) Shower Walls: Extended sheet membrane for the full height of the wall.
- c. Extend sheet membrane over floor drains. Cut drain opening in sheet membrane and seal to drain body. Secure membrane with floor drain clamping ring. Seal sheet membrane watertight to items penetrating sheet membrane.
- d. Install waterproofing to comply with ANSI A108.13 and waterproofing manufacturer's written instructions to produce waterproof membrane of uniform thickness bonded securely to substrate.
- e. Do not install tile over waterproofing until waterproofing has cured and been tested to determine that it is watertight.
- f. Flood test waterproof membranes for 72 hours after fully cured

5. WALL TILE INSTALLATION

- a. Install types of tile designated for wall installations to comply with requirements in the Wall Tile Installation Schedule, including those referencing TCA installation methods and ANSI setting-bed standards.
- b. Joint Widths: Install tile on walls with the following joint widths: refer to installation guidelines for grout joint recommendations at each type of tile.

6. CLEANING AND PROTECTING

- a. Cleaning: On completion of placement and grouting, clean all ceramic tile surfaces so they are free of foreign matter.
 - 1) Remove grout residue from tile as soon as possible.
 - 2) Clean grout smears and haze from tile according to tile and grout manufacturer's written instructions, but no sooner than 10 days after installation. Use only cleaners recommended by tile and grout manufacturers and only after determining that cleaners are safe to use by testing on samples of tile and other surfaces to be cleaned. Protect metal surfaces and plumbing fixtures from effects of cleaning. Flush surfaces with clean water before and after cleaning.
- b. Prohibit foot and wheel traffic from tiled floors for at least seven days after grouting is completed.

END OF SECTION

SECTION 09 50 00 - Wood Panel Ceilings**PART 1 - GENERAL****1.1 RELATED DOCUMENTS**

A. Drawings and general conditions of Contract, including General and Supplementary Conditions and Divisions-1 Specification sections apply to work of this section

1.2 SUMMARY

A. Section Includes

1. Solid Wood and Wood veneer ceiling panels
2. Exposed grid suspension system
3. Wire hangers, fasteners, main runners, wall angle moldings and accessories.

B. Related Sections:

1. Section 09 54 26 - Suspended Wood Ceilings
2. Section 09 53 00 - Acoustical Ceiling Suspension Assemblies
3. Section 09 51 26 - Acoustical Wood Ceilings
4. Section 09 20 00 - Plaster and Gypsum Board
5. Division 23 - HVAC
6. Division 26 - Electrical

C. Alternates

1. Prior Approval: Unless otherwise provided for in the Contract documents, proposed product substitutions may be submitted no later than TEN (10) working days prior to the date established for receipt of bids. Acceptability of a proposed substitution is contingent upon the Architect's review of the proposal for acceptability and approved products will be set forth by the Addenda. If included in a Bid are substitute products that have not been approved by Addenda, the specified products shall be provided without additional compensation.

2. Submittals that do not provide adequate data for the product evaluation will not be considered. The proposed substitution must meet all requirements of this section, including but not necessarily limited to, the following: Single source materials suppliers (if specified in Section 1.5); Underwriters' Laboratories Classified Acoustical performance; Panel design, size, composition, color, and finish; Suspension system component profiles and sizes; Compliance with the referenced standards.

1.3 REFERENCES

A. American Society for Testing and Materials (ASTM):

- 1) ASTM A 1008 Standard Specification for Steel, Sheet, Cold Rolled, Carbon, Structural, High-Strength Low-Alloy and High-Strength Low-Alloy with Improved Formability

- 2) ASTM A 641 Standard Specification for Zinc-Coated (Galvanized) Carbon Steel Wire
- 3) ASTM A 653 Standard Specification for Steel Sheet, Zinc-Coated (Galvanized) by the Hot-Dip Process
- 4) ASTM C 423 Sound Absorption and Sound Absorption Coefficients by the Reverberation Room Method
- 5) ASTM C 635 Standard Specification for Metal Suspension Systems for Acoustical Tile and Lay-in Panel Ceilings
- 6) ASTM C 636 Recommended Practice for Installation of Metal Ceiling Suspension Systems for Acoustical Tile and Lay-in Panels
- 7) ASTM E 84 Standard Test Method for Surface Burning Characteristics of Building Materials
- 8) ASTM E 580 Installation of Metal Suspension Systems in Areas Requiring Moderate Seismic Restraint
- 9) ASTM E 1264 Classification for Acoustical Ceiling Products

B. Hardwood Plywood & Veneer Association (HPVA)

C. International Building Code

D. ASHRAE Standard 62.1-2004 Ventilation for Acceptable Indoor Air Quality

E. NFPA 70 National Electrical Code

F. ASCE 7 American Society of Civil Engineers, Minimum Design Loads for Buildings and Other Structures

G. International Code Council-Evaluation Services - AC 156 Acceptance Criteria for Seismic Qualification Testing of Non-structural Components

H. International Code Council-Evaluation Services Report - Seismic Engineer Report

1. ESR 1308 - Armstrong T-Bar or Dimensional Suspension

I. California Air Resources Board (CARB) compliant

J. LEED - Leadership in Energy and Environmental Design is a set of rating systems for the design, construction, operation, and maintenance of green buildings

1.4 SUBMITTALS

A. Product Data: Submit manufacturer's technical data for each type of ceiling unit and suspension system required.

B. Installation Instructions: Submit manufacturer's installation instructions as referenced in Part 3, Installation.

C. Samples: Minimum 3-1/2 inch or 5-1/2 inch samples of specified panel; 8 inch long samples of exposed wall molding and suspension system, including main runner.

D. Shop Drawings: Illustrating the layout and details of the ceilings. Show locations of items that are to be coordinated with, or supported by the ceilings.

E. Certifications: Manufacturer's certifications that products comply with specified requirements, including laboratory reports showing compliance with specified tests and standards.

F. All products not conforming to manufacturer's current published values must be removed and dispose. Replace with complying product at the expense of the Contractor performing the work.

1.5 QUALITY ASSURANCE

A. Single-Source Responsibility: Provide ceiling panel units and grid components by a single manufacturer.

B. Fire Performance Characteristics: Identify ceiling components with appropriate markings of applicable testing and inspecting organization.

1. Surface Burning Characteristics: As follows, tested by HPVA (Hardwood Plywood and Veneer Association) under the test standard ASTM E-84 tunnel test and complying with ASTM E 1264 for Class A products.

a. Flame Spread: 25 or less

b. Smoke Developed: 50 or less

C. Woodworking Standards: Manufacturer must comply with specified provisions of Architectural Woodworking Institute quality standards.

D. Woodworkds Panels: As with other architectural features located at the ceiling, may obstruct or skew the planned fire sprinkler water distribution pattern through possibly delay or accelerate the activation of the sprinkler or fire detection systems by channeling heat from a fire either toward or away from the device. Designers and installers are advised to consult a fire protection engineer, NFPA 13, or their local codes for guidance where automatic fire detection and suppression systems are present.

E. Coordination of Work: Coordinate ceiling work with installers of related work including, but not limited to building insulation, wet work i.e. gypsum board, light fixtures, mechanical systems, electrical systems, and sprinklers.

1.6 DELIVERY, STORAGE AND HANDLING

A. Store the wood veneer ceiling panels in a dry interior location in their cartons prior to installation to avoid damage. Store the ceiling panel cartons in a flat, horizontal position. Do not remove the protectors between the panels until installation.

B. Do not store in unconditioned spaces with humidity greater than 55 percent or lower than 25 percent relative humidity and temperatures lower than 50 degrees F or greater than 86 degrees F. Do not expose the wood veneer ceiling panels to extreme temperatures, for example, close to a heating source or near a window with direct sunlight.

C. Handle ceiling units carefully to avoid chipped edges or damage to units in any way.

1.7 PROJECT CONDITIONS

A. Prior to installation, the wood veneer ceiling materials are required to reach room temperature and have stabilized moisture content for a minimum of 72 hours.

B. Do not install the wood veneer panels in spaces where the temperature or humidity conditions vary greatly from the temperatures and conditions that will be normal in the occupied space.

C. As interior finish products, the wood veneer panels are designed for installation in temperature conditions between 50 degrees F and 86 degrees F, in spaces where the building is enclosed and HVAC systems are functioning and will be in continuous operation. Relative humidity should not fall below 25 percent or exceed 55 percent.

1.8 WARRANTY

A. Wood Veneer Panel: Submit a written warranty executed by the manufacturer, agreeing to repair or replace panels that fail within the warranty period. Failures include, but are not limited to:

1. Ceiling Panels: Defects in materials or factory workmanship
2. Grid System: Rusting and manufacturing defects

B. Warranty Period:

1. Wood veneer panels: One (1) year from date of installation
2. Grid: One (1) year from date of installation

C. The Warranty shall not deprive the Owner of other rights the Owner may have under other provisions of the Contract Documents and will be in addition to and run concurrent with other warranties made by the Contractor under the requirements of the Contract Documents.

1.9 MAINTENANCE

A. Extra Materials: Deliver extra materials to Owner. Furnish extra materials described below that match products installed. Packaged with protective covering for storage and identified with appropriate labels.

1. Ceiling Units: Furnish quantity of full-size units equal to 5.0 percent of amount installed.

2. Exposed Suspension System Components: Furnish quantity of each exposed suspension component equal to 2.0 percent of amount installed.

PART 2 - PRODUCTS

2.1 MANUFACTURERS

A. Ceiling Panels:

1. Armstrong World Industries, Inc.

B. Suspension Systems:

1. Armstrong World Industries, Inc.

2.2.1 WOOD VENEER CEILING UNITS

A. Ceiling Panels Type AP:

1. Surface Texture: Smooth
2. Composition: Fire-retardant Particle Board
3. Species/Finish: Natural Variations Maple
4. Size: 24 in x 24 in
5. Reveal: Square Tegular 9/16 in
6. Profile: 9/16 in
7. Sabin: N/A
8. Edge Banding and Trim: To match face veneer
9. Noise Reduction Coefficient (NRC):
10. Flame Spread: ASTM E84 HPVA Fire Classification (Fire Class)
11. Dimensional Stability: Standard
12. Acceptable Product: WOODWORKS Tegular, Item # 5406W5 as manufactured by Armstrong World Industries

B. Ceiling Accessories (Ceilings) WoodWorks:

1. 5659W1 - 4" WoodWorks Trim (with aluminum substrate)
2. 8200T10 - 1" Fiberglass Infill Panel (in poly bag)

2.3.1 METAL SUSPENSION SYSTEMS

A. Components:

Main beams and cross tees, base metal and end detail, fabricated from commercial quality hot dipped galvanized steel complying with ASTM A 653. Main beams and cross tees are double-web steel construction with type exposed flange design. Exposed surfaces chemically cleansed, capping prefinished galvanized steel in baked polyester paint. Main beams and cross tees shall have rotary stitching.

a. Structural Classification: ASTM C 635 Heavy Duty duty

b. Color: Tech Black and match the actual color of the selected ceiling tile, unless noted otherwise.

c. Acceptable Product: SUPRAFINE XL 9/16" Exposed Tee as manufactured by Armstrong World Industries

B. Attachment Devices:

Size for five times design load indicated in ASTM C 635, Table 1, Direct Hung unless otherwise indicated.

C. Wire for Hangers and Ties:

ASTM A 641, Class 1 zinc coating, soft annealed, with a yield stress load of at least time three design load, but not less than 12 gauge.

D. Wood Works Edge Moldings and Trim:

1. 7800 - 12' Wall Molding

E. WoodWorks Suspension Accessories:

1. 5594 - Compression Strut

2.4.1 ALUMINUM CUSTOM TRIM - EXTRUDED

Product/Manufacturer: Axiom Trim Channel: 4in Axiom Classic Straight Armstrong World Industries, Incorporated

A. Commercial quality extruded aluminum alloy 6063 trim channel, factory finished in baked polyester paint. Commercial quality galvanized steel unfinished T-bar connection clips; galvanized steel splice plates.

1. Color: Wood Looks Maple

2. Size: 120 in X 4 in

3. Recycle Content: Post-Consumer - 10% Pre-Consumer - 35%

4. Acceptable Product: AXIOM Classic, 4in Axiom Classic Straight as manufactured by Armstrong World Industries

B. Axiom Trim Channel:

4in Axiom Classic Straight

C. Axiom Outside Corner Posts (Straight Only):

None

D. Axiom Inside Corners (Straight Only):

None

E. Axiom Accessories:

None

PART 3 - EXECUTION**3.1 EXAMINATION**

A. Do not proceed with installation until all wet work such as concrete, terrazzo, plastering and painting has been completed and thoroughly dried out.

B. Proper designs for both supply air and return air, maintenance of the HVAC filters and building interior space are essential to minimize soiling. Before starting the HVAC system, make sure supply air is properly filtered and the building interior is free of construction dust.

3.2 PREPARATION

A. Measure each ceiling area and establish layout of acoustical units to balance border widths at opposite edges of each ceiling. Avoid use of less than half width units at borders, and comply with reflected ceiling plans. Coordinate panel layout with mechanical and electrical fixtures.

3.3 INSTALLATION

A. Install suspension system and panels in compliance with ASTM C636; CISCA Seismic Guidelines; approved construction drawings; with the authorities having jurisdiction; and in accordance with the manufacturer's installation instructions.

B. Install wall moldings at intersection of suspended ceiling and vertical surfaces.

3.4 ADJUSTING AND CLEANING

A. Replace damaged and broken panels.

B. Clean exposed surfaces of ceilings panels, including trim, edge moldings, and suspension members. Comply with manufacturer's instructions for cleaning and touch up of minor finish damage. Remove and replace work that cannot be successfully cleaned and repaired to permanently eliminate evidence of damage.

SECTION 09 51 00 – CEILING SUSPENSION

PART 1 - GENERAL

1.1 SUMMARY

- A. Work Included: Provide and install ceiling suspension systems, complete, as shown on Drawings and as specified for the following ceiling finish systems:
1. Gypsum Board Ceilings, coordinated with the Work of Section 09 29 0 – Gypsum Board.
 2. Lay-in Acoustical Ceilings, coordinated with the Work of Section 09 51 13 – Acoustical Ceilings.
 3. Lay-in Acoustical Ceilings for MRI rooms, including non-ferrous suspension components, coordinated with the Work of Section 09 51 13 – Acoustical Ceilings.
- B. Work Specified Elsewhere:
1. Section 01410 – Testing and Inspection Services
 2. Section 05 05 00 – Metal Fasteners.
 3. Section 08 31 13 – Access Panels.
 3. Section 09 22 16 – Non Structural Metal Framing.
 4. Section 09 51 13 – Acoustical Ceilings.
 5. Divisions 15 and 16 – Mechanical and Electrical Work in Suspended Ceilings.

1.2 REFERENCE STANDARDS

- A. American Society for Testing and Materials (ASTM):
1. C635; Standard Specification for Metal Suspension Systems for Acoustical Tile and Lay-In Panel Ceilings.
 2. C754; Standard Specification for Installation of Steel Framing Members to Receive Screw-Attached Gypsum.
 3. C841; Standard Specification for Installation of Interior Furring and Lathing.
 4. C1063; Standard Specification for Installation of Lathing and Furring for Portland Cement-Based Plaster.

5. C636; Standard Specification for Installation of Metal Suspension System for Acoustic Tile and Lay-In Panels.
 6. Cisca Ceiling Systems Installation Handbook.
- B. International Building Code (IBC) with 2003 Utah Amendments.

1.3 SUBMITTALS

- A. Comply with requirements of Section 01330 – Submittal Procedures.
- B. Samples:
1. Exposed Suspension System Components: 12-inch-long piece of each item specified.
- C. Shop Drawings: Show following:
1. Layout of suspension systems, location of hangers, seismic braces and trapezes, indicating location of fixed and free side of layouts.
 2. Hanger spacing and fastening details.
 3. Trapeze details.
 4. Splicing method for main and cross runners.
 5. Support at ceiling fixtures and air diffusers.
 6. Change in level details.
 7. Locations and dimensions of access panels, light fixtures, supply and exhaust grilles and diffusers, sprinkler heads, speakers, and detection devices.
 8. Seismic control details.
 9. Develop and coordinate location of all Work which is to be located in ceiling with the Sections involved per Section 01330 – Submittal Procedures prior to making shop drawing submittal.
- D. Product Data: Manufacturer's information on materials, fabrication, and installation. Provide certification of flame spread rating and UL classification.

1.4 QUALITY ASSURANCE

- A. Allowable Tolerances:
1. Deflection: Do not exceed a maximum of $L/360$ of span.
 2. Level: Do not deviate from level in excess of 1/8 inch in 12 feet.

B. Testing:

1. If required by local authority, special inspection services may be implemented, refer to Section 01410 – Testing and Inspection Services.
2. Fasteners: As specified in Section 05050 – Metal Fasteners.

1.5 PRE-INSTALLATION CONFERENCE

A. Comply with requirements of Section 01315 – Project Meetings.

B. Arrange a conference at the job site to coordinate interior wall, partition and ceiling installation, to be attended by the Owner, Architect, Contractor, and personnel involved in the actual manufacture and installation of the Work of the following Sections:

1. Section 07220 – Acoustical Insulation.
2. Section 07840 – Fire Stopping and Smoke Seals.
3. Section 09110 – Interior Wall Framing.
4. Section 09120 – Ceiling Suspension.
5. Section 09250 – Gypsum Board.
6. Section 09265 – Shaft Wall Systems.
7. Section 09510 – Acoustical Ceilings.
8. DIVISION 15 – Mechanical.
9. DIVISION 16 – Electrical.

1.6 PRODUCT HANDLING

- A. Delivery: Deliver products and materials in original unopened packages, containers, or bundles with manufacturer's label intact and legible.
- B. Damaged Items: Remove items delivered in broken, damaged, rusted, or unlabeled condition from Project site immediately.
- C. Manufacturer's Recommendations: Follow additional delivery, storage, and handling requirements of manufacturer.

1.7 PROJECT CONDITIONS

- A. Concealed Work: Ensure that work concealed by suspended ceilings be complete, tested if required, inspected, and approved prior to commencement of installation of materials specified herein.

- B. Environmental Conditions: Do not commence installation until area has been closed in, and temperature and humidity conditions are similar to those expected during building occupancy.
- C. Wet Work: Complete and cured, prior to commencement of installation of suspended ceilings.

PART 2 - PRODUCTS

2.1 MATERIALS

A. Framing:

- 1. General: Types specified are products of Western Metal Lath Company. Structural characteristics and quality of substitutions shall meet or exceed those of types specified and referenced standards.
- 2. Main Runners: 1-1/2-inch-deep cold-rolled (0.475 pound/foot) or hot-rolled (1.12 pound/foot) steel channels, galvanized for exterior work and rust-inhibitive coated for interior work.
- 3. Cross Furring: 3/4-inch-deep cold- or hot-rolled (0.3 pound/foot) steel channels, galvanized for exterior work and rust-inhibitive coated for interior work.
- 4. Furring Channels: 7/8-inch hat-shaped channels, 25-gauge hot-rolled channel at gypsum board ceilings; rust inhibitive finish.
- 5. Clips: Galvanized steel, of sizes and shapes shown. 16-gauge, except as otherwise shown.

B. Fasteners:

- 1. Sheet Metal Screws: To suit channel gauge, as specified in Section 09110 – Metal Support Systems.
- 2. Expansion Bolts:
 - a. Tie Wire: Hilti Kwik Bolt HKT 14, Ramset/Red Head TW, or equal, with minimum 1-1/2-inch embedment.
 - b. Others: As specified in Section 05050 – Metal Fasteners.
- 3. Powder-Actuated Devices (PAD's):
 - a. As specified in Section 05050 – Metal Fasteners and as follows:
 - 1) Size: 0.145-inch diameter with 15/16-inch minimum penetration.
 - 2) For Attachment of Ceiling Clips: Hilti DN 27 P8T, or equal.

4. Pop Rivets: 3/16-inch-diameter plated steel.
 5. Machine Bolts: ASTM A307, Grade A, regular hexagon head type with ASTM A563, Grade A nuts. 1/4-inch size unless otherwise shown.
- C. Hanger, Bracing and Tie Wires:
1. FS QQ-W-461H, Finish 5, Class 1, soft temper or ASTM A 641, Class 1 coating, soft temper.
 2. Minimum gauges:
 - a. Hangers, 8.
 - b. Diagonal bracing wire, 12.
 - c. Single-strand tie wire, 16.
 - d. Double-strand tie wire, 18.
- D. Welding Electrodes: AWS, low hydrogen type, as required.
- E. Ceiling Clips: "BERC2" Clips in conformance with IBC Seismic category D, E, and F requirements for specified ceiling grid systems.
- F. Seismic Brace:
1. General: Provide compression post and four 12-gauge galvanized steel wires splayed at 45 degrees vertically and spaced at 90 degrees horizontally to each other and attached to main runner or grid member with 2-inches of compression post.
 2. Wire Attachment: PAD devices not permitted for attachment of brace wires. Fasten bracing wires at each end with not less than 4 tight turns within distance of 1-1/2 inches, except machine made wire turns, where both strands have been deformed or bent in wrapping, need not comply with 1-1/2-inch distance requirement as long as turns are tight as possible and four in number.
- G. Compression Posts: Provide compression posts as shown on Drawings and as specified, including:
1. Angle Strut Type: Steel sheet angles or channels, not less than 16-gauge, L/R ratio of 200 maximum.
 2. EMT Type: Electrical metallic tubing, diameters shown.
 3. Metal Stud Type: 2-inch by 4-inch steel stud, 16-gauge. Attach to main channel with three No. 10 screws. Attach to structure per drawings.
 4. Proprietary Type: Use at Contractor's option in lieu of angle strut or EMT types. USG's Donn Series VSA Compression Post, or equivalent, galvanized steel telescoping post with top clip, bulb clip, guide ring,

and locking device. Provide size recommended by manufacturer for span.

- H. Suspension System for Acoustical Ceilings:
1. General: Provide each component as products of a single manufacturer.
 2. Type: Comply with ASTM C 635 Structural Classification as "Heavy Duty" Systems, for direct hung installation with interlocking main runners and cross runners. Roll-formed grid components composed of double web hot-dipped galvanized steel.
 - a. Structural Classification: UL Certified in compliance with CBC Chapter 16 criteria.
 3. Manufacturer: CertainTeed, Armstrong World Industries; USG Interiors, Inc; Chicago Metallic;. Products from CertainTeed are the Basis-of-Design for coordinated suspension components and acoustical ceiling panels.
 4. Grid System:
 - a. For use with the following acoustic ceiling types: ACP-1, ACP-2, ACP-3 and ACP-4 as specified in Section 09 51 13 – Acoustical Panel Ceilings
 - b. Manufacturer: CertainTeed
 - c. Type: CertainTeed Classis Stab System, Heavy duty 15/16" Tee System; and 15/16" wall molding; including CertainTeed Seismic Perimeter Clip for seismic categories D, E and F.
 - d. Surface Finish: Baked polyester paint. Color: White
 5. Typical Perimeter Angles: With matching corner caps and splice pieces; same material as that of exposed suspension system members, 15-gauge with hemmed edge, typical.
 - a. Finish: Baked polyester paint. Match adjacent grid system.
 7. Slip Joints: MM Systems Corp.'s Series DX-100, or equal, white polyvinyl-chloride flexible extrusion for 1-inch-wide joint.
 8. Slotted Angle Spacer: Slotted angles or channels with spring steel diamond points which snap tight to prevent movement of strut.
 9. Miscellaneous Accessories: Manufacturer's standard for use with suspension system furnished; furnish as required.
- I. Sound Isolation Clips: As specified in Section 09110 – Non-Load Bearing Wall

Framing.

- J. Miscellaneous: Provide manufacturer's standard miscellaneous items and accessories suitable for use intended and required for complete installation.

PART 3 - EXECUTION

3.1 EXAMINATION

- A. Verification of Conditions: Examine conditions under which ceiling suspension systems are to be installed. Give notification in writing, of conditions detrimental to proper and timely completion of Work. Proceed only when conditions are satisfactory.

3.2 INSTALLATION

- A. Hanger Wires:
 - 1. Spacing:
 - a. For Gypsum Board, Metal Ceilings, and Acoustical Ceilings: 4-foot centers maximum.
 - 2. Clearance: Not less than 6-inches between hanger wires and unbraced ducts, pipes, and conduit.
 - 3. Attachment to Structure Above: Use wire pigtail embedded in concrete, tie wire type expansion bolt, or PAD with ceiling clip, as appropriate.
 - 4. Hanger Wires: Fasten hanger wires to attachment device at structure above with not less than 3 tight turns within distance of 1-1/2-inches, except machine-made wire turns, where both strands have been deformed or bent in wrapping, need not comply with 1-1/2-inch distance requirement as long as turns are as tight as possible and 3 in number.
 - 5. Wire Size:
 - a. For Gypsum Board Soffits and Ceilings: 8-gauge.
 - b. For Acoustical and Metal Panel Ceilings: 12-gauge at inaccessible and 10-gauge at accessible areas.
 - 6. Out-Of-Plumb Wires: Install hanger wires as near plumb as possible. Where hanger wires are more than 1 (horizontal) to 6 (vertical) out of plumb, provide counterbrace wires.
- B. Trapezes: Provide trapezes or other supplementary support members at obstructions in order to maintain specified hanger spacing. Provide additional hangers, struts or braces as required at all ceiling breaks, soffits or discontinuous areas. Counter-balance out-of-plumb wires as specified.

- C. Additional Hanger Wires: Provide as required at ceiling breaks, soffits, and discontinuous areas.
- D. Gypsum Board Ceiling Suspension System:
 - 1. Runner Channels:
 - a. Spacing: 4-foot maximum centers.
 - b. Attachment: Saddle tie with hanger wires at 4-foot maximum centers. Make 2 loops and secure with not less than 3 turns in 1-1/2-inch maximum distance.
 - c. Splice: Lap and interlock flanges 12 inches minimum and tie near each end with double loops of 16-gauge tie wire.
 - 2. Furring Channels:
 - a. Spacing: 16-inch maximum centers.
 - b. Attachment: Saddle tie with 16-gauge tie wire to runner channels and secure with no less than 3 tight turns.
 - c. Splice: Lap and interlock 8-inches minimum and tie near each end with double loops of 16-gauge tie wire.
- E. Acoustical Ceiling Panel and Metal Ceiling Panel suspension system:
 - 1. General: Install per Reference Standards, manufacturer's instructions, and reviewed shop drawings.
 - 2. Main Grid Members:
 - a. Spacing: 4-foot maximum centers.
 - b. Attachment: Tie with hanger wire secured with not less than 3 turns in 1-1/2-inch maximum distance.
 - c. Lighting Fixtures, Air Terminals, and Other Services Less Than 56 Pounds in Weight: Secure with slack hanger wires at two corners.
 - d. Lighting Fixtures, Air Terminals, and Other Services Greater Than 56 Pounds in Weight: Secure with hanger wires at four corners and as shown on Drawings.
 - 3. Secondary Grid Members:
 - a. Spacing: 2-foot maximum centers.
 - b. Attachment: Form 2-foot by 2-foot grid with positive splices.

- F. Seismic Restraint:
1. General: Provide as follows for each type suspension system.
 2. Spacing:
 - a. Areas Less Than 96-Square Feet:
 - 1) No Dimension Greater Than 12-Feet: No bracing required.
 - 2) Dimension Greater Than 12-Feet: Provide bracing.
 - b. Areas Greater Than 96-Square Feet: Provide brace for each 96-square feet or fraction thereof.
 - c. Maximum Brace Spacing: 8-feet by 12-feet.
 - d. Maximum Distance From Walls: 1/2-brace spacing in direction perpendicular to plane of wall.
 3. Seismic Brace:
 - a. General: Provide compression post and four 12-gauge galvanized steel wires splayed at 45 degrees vertically and spaced at 90 degrees horizontally to each other and attached to main runner or grid member with 2-inches of compression post.
 - b. Wire Attachment: Powder-actuated devices not permitted for attachment of brace wires. Fasten bracing wires at each end with not less than 4 tight turns within distance of 1-1/2-inches, except machine made wire turns, where both strands have been deformed or bent in wrapping, need not comply with 1-1/2-inch distance requirement as long as turns are as tight as possible and 4 in number.
- I. Access Panels: Frame as required for access panels furnished under Divisions 15 and 16 and specified under Section 08310 –Access Panels.

END OF SECTION

SECTION 09 51 10 – CEILING SUSPENSION- ALUMINUM

PART 1 – GENERAL

1.1 RELATED DOCUMENTS

A. Drawings and General Provisions of the Contract, including General and Supplementary Conditions and Division 1 Specification Sections apply to this Section.

1.2 SUMMARY

A. This section includes extruded aluminum grid system and perimeter.

1.3 REFERENCES

- A. ASTM C635, Standard Specification for Metal Suspension Systems for Acoustical Tile and Lay-in Panel Ceilings.
- B. ATSM C636, Recommended Practice for Installation for Metal Suspension for Acoustical Tile and Lay-in Panels
- C. CISCA Ceiling Systems Installation Handbook.

1.4 SUBMITTALS

A. Manufacturer's Literature and Data:

- 1. Product Data: Submit manufacturer's technical data and brochures for each type of specified system required. All products furnished shall have a flame spread classification on 0-25 for a Class A or 1 rating in accordance with ASTM-423.

B. Shop drawings shall show dimensions, sizes, thickness, alloys, tempers, finishes, joining, attachments and relationship of adjoining work.

C. Samples:

- 1. Samples shall include a three, 12" pieces of each type of suspension and finish as specified including perimeter molding and accessories.

D. Certification:

- 1. Submit certification from manufacturer of suspension system attesting that products comply with specified requirements including finish as specified.

E. Qualification Data:

- 1. Firms specified in "Quality Assurance" Article must demonstrate their capabilities and experience by including lists of completed projects with

project names and addresses, names and addresses of architects and owners, and other information specified.

1.5 QUALITY ASSURANCE

- A. Manufacturer: Firm with manufacturing and delivery capacity required for the project, shall have successfully completed at least ten projects within the past five years, utilizing systems, materials and techniques as herein specified.
- B. Fabricator must own and operate its own manufacturing facilities for all metal components. "Stick Built" or "Kit of Parts Systems" consisting of components from a variety of manufacturers will not be considered or accepted.
- C. Manufacturer/Fabricator must own and operate its own Painting and Finishing facility to assure single source responsibility and quality control.

1.6 DELIVERY, STORAGE & HANDLING

All materials shall be protected during fabrication, shipment, site storage and erection to prevent damage to the finished work from other trades. Store accessories inside a well-ventilated area, away from uncured concrete and masonry, and protected from the weather, moisture, soiling, abrasion, extreme temperatures, and humidity.

PART 2 - PRODUCTS

2.1 MANUFACTURER

- A. Gordon Extruded Aluminum CG Suspension Systems shall be manufactured by Gordon Interior Specialties Division, Gordon, Inc., 5023 Hazel Jones Road, Bossier City, LA 71111, (800) 747-8954, Fax (800) 877-8746, www.gordoninteriors.com, sales@gordoninteriors.com.
- B. The listed manufacturer shall not be construed as closing specifications to other prospective manufacturers, but rather as establishing a level of quality in a metal system. Other systems may be submitted for approval; as provided for in the specifications at least 10 working days prior to submission of bids. Companies desiring to submit a proposal shall submit all descriptive information of the system proposed including photographs and shop drawings of at least three projects similar in detail and scope.

2.2 SYSTEM Description

- A. The ceiling Suspension System shall be CG (10, 15, or 20) series. Modular ceiling suspension system shall consist of 12' 0" main tees and/or 2' 0" nominal cross tees manufactured of extruded aluminum components by Gordon, Inc. All members shall be of standard 6063-T5 aluminum alloy. Each cross tee shall be factory fabricated for independent aluminum bend-tab clips on each end.
- B. Main tees, cross tees, and wall angle shall be high performance white powder coat finish.

- C. All components shall be extruded aluminum, meeting all loading data. No roll formed aluminum grid will be allowed.
- D. Main tees shall be joined together at each end by means of an independent aluminum bend-tab splice member.
- E. Cross tees shall attach to main tees and other cross tees by means of an independent aluminum bend-tab clip which penetrates and slides through slots in the main tees and other cross tees.
- F. All grid components have factory applied 3/32" x 3/8" (CG-10), 3/32" x 15/32" (CG-15), or 3/32" x 3/4" (CG-20) white closed-cell polyethylene gasket with adhesive on one side. Polyethylene gasket must pass fungus resistance test method 508.1 mill-std 810C flame resistance test FMYSS 302 with burn rate of 4" per minute. Shore hardness of gasket must be 7 on AA scale and 51 on OO scale per ASTM D-2240. The gasket must be 2 lb. density per cubic foot and meet USDA approval.
- G. The system shall comply with ASTM C-635 "Metal Suspension Systems for acoustical tile and lay-in panel ceilings", with intermediate duty (CG-10 & CG-15) and heavy duty (CG-20) designation.

2.3 MATERIALS

- A. Extruded CG Suspension System
 - 1. Extruded CG Suspension System as manufactured by Gordon, Inc., shall consist of Main tees (list finish and profile number), Cross tees (list finish and profile number), Perimeter Wall Angle (list finish and profile number), and all necessary clips and splices required for a complete system as required to meet local building codes.
 - 2. Deflection of grid shall be limited to L/360 of span (1/8" maximum) when full dead load is applied.
 - 3. Aluminum extrusion shall be 6063-T-5 alloys. (ASTM B221, ASTM B 221 M)
 - 4. General: Provide metals free from surface blemished where exposed to view in finished unit. Surfaces exhibiting pitting, seam marks, roller marks. Stains, and discolorations, or other imperfections on finished units are not acceptable. All metal shall be of the highest-grade commercial type.

2.4 FABRICATION

- A. The suspension module will be (Specify size, i.e. 2' x 4').
- B. All intersections between main tees and cross tees shall be butt cut and notched as required.
- C. Perimeter shall be fabricated to match the system described in paragraph 2.2.

- D. All components including accessories are available to meet codes such as seismic and loads such as light fixtures and air diffusers.
- E. Hanger wires (furnished by the Ceiling Contractor) shall be #12 gauge galvanized without kinks and splices.

2.5 FINISHES

- A. All suspension components visible shall receive a micro-etched pretreatment prior to receiving an electrostatically applied Acrylic-Polyester hybrid powder coat paint finish.

PART 3 – EXECUTION

3.1 INSPECTION

- A. Examine building structure schedule of receive ceiling system for unevenness or irregularities that would affect quality and execution of work.
- B. Tolerances:
 - 1. Install ceiling system with maximum permissible deflection of L/360 of span maximum surface deviation of 1/8" in 10'-0" (no load applied) ASTM 635-92.

3.2 INSTALLATION

- A. General: Comply with manufacturer's printed instructions, with governing regulations for Seismic Codes, and with the Ceiling & Interior Systems Construction Association standards applicable to work.

3.3 CLEANING

- A. Clean all surfaces following installation. If necessary use only a mild soap or detergent solution such as TSP-90 or Ivory.
- B. Replace units having scratches, abrasions, or other defects with unblemished panels or suspension.
- C. Maintenance per manufacturer's finished maintenance instructions.

3.4 PROTECTION

- A. Protection of Gordon Systems from damage by other trades after installation to be provided by general contractor.

3.5 GENERAL RESPONSIBILITY

- A. Variation from specification: Any variation from this specification resulting in additional cost to any other contractor or subcontractor on this project shall be the sole financial responsibility of the contractor for the work of this section.

SECTION 09 51 13 – ACOUSTICAL PANEL CEILINGS

PART 1 - GENERAL

1.1 SUMMARY

- A. Work Included: Provide and install acoustical ceilings panels and accessories, complete, as shown and specified, including:
 - 1. Mineral core acoustical ceiling panels.
- B. Work Specified Elsewhere:
 - 1. Section 092216 – Non-Structural Metal Framing.
 - 2. Section 122200 – Curtains and Drapes.
 - 3. Division 23 – Mechanical (Air Supply, Ducts, and Connections).
 - 4. Division 26 – Electrical (Lighting Fixture Attachments).

1.2 REFERENCE STANDARDS

- A. American Society for Testing and Materials (ASTM):
 - 1. C635; Metal Suspension Systems for Acoustical Tile and Lay-In Panel Ceilings.
 - 2. C636; Standard Practice for Installation of Metal Ceiling Suspension Systems for Acoustical Tile and Lay-In Panels.
- B. Ceiling and Interior System Contractors Association (CISCA):
 - 1. Ceiling Systems Handbook.

1.3 SYSTEM DESCRIPTION

- A. Performance Criteria:
 - 1. Fire-Hazard Classification: Provide acoustical ceilings that are identical to those tested for following fire hazard characteristics, per ASTM test method indicated below, by UL or other testing and inspecting organizations acceptable to authorities have jurisdiction. Identify acoustical ceiling components with appropriate markings of applicable testing and inspecting organization.
 - a. Test Method: ASTM E84.
 - b. Flame Spread: 25 or less.
 - c. Smoke Developed: 50 or less.

1.4 SUBMITTALS

- A. Comply with requirements of Section 013300 – Submittal Procedures.
- B. Product Data: Manufacturer's specifications, data, and installation instructions.
- C. Shop Drawings:
 - 1. Coordination Drawings: Reflected ceiling plans drawn accurately to scale and coordinating penetrations and ceiling-mounted items. Show following:
 - a. Ceiling suspension members.
 - b. Method of attaching hangers to building structure.
 - c. Ceiling-mounted items including light fixtures; air outlets and inlets; speakers; sprinkler heads; and special moldings at walls, column penetrations, and other junctures with adjoining construction.
- D. Samples:
 - 1. For Initial Selection: Manufacturer's standard sample sets consisting of actual acoustical units or sections of units showing full range of colors, textures, and patterns available for each type of unit indicated.
 - 2. For Verification: 12-inch-square sample of each type of exposed finish specified or selected and of same thickness and material indicated for final unit of Work. Where finishes involve normal color and texture variations, include sample sets showing full range of variations expected.
- E. Qualification Data: For firms and persons specified in Quality Assurance article to demonstrate their capabilities and experience. Include list of completed projects with project names, addresses, names of Architects and Owners, and other information specified.
- F. Research Reports: Or evaluation reports of model code organization acceptable to authorities having jurisdiction that show compliance of acoustical ceiling system and components with building code in effect for Project.
- G. Product Test Reports: From qualified independent testing agencies that are based on its testing or current products for compliance of acoustical ceiling systems and components with requirements.

1.5 QUALITY ASSURANCE

- A. Qualifications of Installer: Engage experienced Installer who has successfully completed acoustical ceilings similar in material, design, and extent to those indicated for Project.
- B. Single-Source Responsibility: Obtain each type of acoustical ceiling unit from single source with resources to provide products of consistent quality in appearance and physical properties without delaying progress of Work.

- C. Coordination of Work: Coordinate layout and installation of acoustical ceiling units and suspension system components with other construction that penetrates ceilings or is supported by them, including light fixtures, HVAC equipment, fire-suppression system components (if any), and partition system (if any).

1.7 PRODUCT HANDLING

- A. Delivery and Storage: Deliver acoustical ceiling units to Project site in original, unopened packages and store them in fully enclosed space protected against damage from moisture, direct sunlight, surface contamination, and other causes.
- B. Handling: Handle acoustical ceiling units carefully to avoid chipping edges or damaging units in any way.

1.8 PROJECT CONDITIONS

- A. Storage: Before installing acoustical ceiling units, permit them to reach room temperature and stabilized moisture content.
- B. Space Enclosure: Do not install acoustical ceilings until space is enclosed and weatherproof, wet-work in space is completed and nominally dry, work above ceilings is complete, and ambient conditions of temperature and humidity will be continuously maintained at values near those expected for final occupancy.

PART 2 - PRODUCTS

2.1 MINERAL CORE ACOUSTICAL PANELS

- A. Manufacturer: Provide products manufactured by Armstrong World Industries; USG; or equal.
 - 1. Basis-of-Design: Armstrong World Industries products are specified as the basis of design.
- B. Mineral Core Acoustical Panel Types:
 - 1. Type 1:
 - a. General: Armstrong Ultima Health Zone (Item # 1935)
 - b. Size: 24 inches by 24 inches by 3/4-inch-thick.
 - c. Edge Detail: Square Lay-In.
 - d. Noise Reduction Coefficient: UL Classified NRC of 0.70 in compliance with ASTM C423.
 - e. Sound Transmission Class: UL Classified CAC minimum of 38 in compliance with ASTM E1414 or ASTM E413.
 - f. Light reflectance: 0.86
 - g. Provide manufacturer's coordinated field and border units, as required by layouts shown on Drawings.
 - h. Specified grid system: Armstrong's Prelude XL 15/16-inch exposed tee.

2. Type 2:
 - a. General: Armstrong Ultima Health Zone (Item # 1938)
 - b. Size: 24 inches by 48 inches by 3/4-inch-thick.
 - c. Edge Detail: Square Lay-In.
 - d. Noise Reduction Coefficient: UL Classified NRC of 0.70 in compliance with ASTM C423.
 - e. Sound Transmission Class: UL Classified CAC minimum of 38 in compliance with ASTM E1414 or ASTM E413.
 - f. Light reflectance: 0.86
 - g. Provide manufacturer's coordinated field and border units, as required by layouts shown on Drawings.
 - h. Specified grid system: Armstrong's Prelude XL 15/16-inch exposed tee.

3. Type 3:
 - a. General: Armstrong Clean Room VL (Item # 870)
 - b. Size: 24 inches by 48 inches by 5/8-inch-thick.
 - c. Edge Detail: Square Lay-In.
 - e. Sound Transmission Class: UL Classified CAC minimum of 40 in compliance with ASTM E1414 or ASTM E413.
 - f. Light reflectance: 0.80
 - g. Provide manufacturer's coordinated field and border units, as required by layouts shown on Drawings.
 - h. Specified grid system: 15/16-inch aluminum gasketed heavy duty clean room ceiling grid system by Gordan.

PART 3 - EXECUTION

3.1 EXAMINATION

- A. Verification of Conditions: Examine substrates and structural framing to which ceiling system attached or abuts, with Installer present, for compliance with requirements specified in this and other sections that affect installation and anchorage of ceiling system. Do not proceed with installation until unsatisfactory conditions have been corrected.

3.2 INSTALLATION

- A. General: Install acoustical ceiling systems per Reference Standards and manufacturer's instructions.
- B. Acoustical Ceiling Tiles:
 1. General: Make joints straight and true to line with exposed surfaces flush and level. Tightly butt tiles with corners and arises full and without broken edges.
 2. Suspended System:

- a. Concealed Grid: Install tile with concealed metal splines in kerfed edges between tiles to form concealed mechanical joints.
- b. Edge Units: Install spring steel spacers where supported on edge trim.
- c. Access Tile: Install units by concealed saddle and notched hook spline method.
- d. Identification Markers: Install one per access tile; locate on tile as directed.

3.3 CLEANING

- A. Cleaning: Clean exposed surfaces of acoustical ceiling panels. Comply with manufacturer's instructions for cleaning and touch-up of minor finish damage. Remove and replace work that cannot be successfully cleaned and repaired to permanently eliminate evidence of damage.

END OF SECTION

SECTION 09 65 19 – RESILIENT FLOORING

PART 1 - GENERAL

1.1 SUMMARY

- A. Work Included: Provide and install resilient flooring, resilient base and accessories, complete as shown on Drawings and as specified, including:

1. ~~Luxury Vinyl Plank~~
2. Homogeneous sheet vinyl, heat welded including integral coved base.
3. Resilient Base.
4. Edge Strips, Reducer Strips and other floor-edge transitions.
5. Cap trim, cove-shaped furring, and accessories for cove base installations.
6. Hot Weld Strips and cold seam materials.
7. Adhesives and other accessory materials as required to provide complete floor assemblies as specified.

- B. Work Specified Elsewhere:

1. Section 035300 – Concrete Toppings.
2. Section 087100 – Door Hardware.
3. Section 093000 – Tile.

1.2 REFERENCE STANDARDS

- A. Resilient Floor Covering Institute (RFCI).
- B. American Society for Testing and Materials (ASTM):
1. ASTM E-1907-98: "Standard Practices for Determining Moisture-Related Acceptability of Concrete Floors to Receive Moisture-Sensitive Finishes".

2. ASTM F-1869-89: "Standard Test Method for Measuring Moisture Vapor Emission Rate of Concrete Subfloor Using Anhydrous Calcium Chloride".

1.3 SUBMITTALS

- A. Comply with requirements of Section 013300 – Submittal Procedures.
- B. General: Schedule submittals as required to provide a minimum of 60-days from flooring materials order day to start of installation.
- C. Shop Drawings: Provide seaming diagrams for public spaces including corridors.
- D. Samples:
 1. Edge, Reducer and Transition Strips: Each specified type and color, 12 inches long.
 2. Resilient Tile Flooring: 2 samples, each type and color specified, 12 inches square.
 3. Resilient Sheet Flooring: 2 samples, each type and color specified, 12 inches square.
 4. Resilient Base: 2 samples each type and color, 12 inches long. None required for black color.
- E. Product Data: Manufacturer's specifications, data, and installation instructions.
- F. Qualifications: Submit Contractor's and Installer's project lists and specified manufacturer certifications, including project names and addresses and contact names and telephone numbers.
- G. Maintenance Manuals: Manufacturer's written maintenance instructions.

1.4 QUALITY ASSURANCE

- A. Qualifications of Installer: Minimum of three project installations of extent comparable to proposed Project.
- B. Regulatory Requirement: Materials shall have the following flammability ratings, according to NFPA 253:
 1. Smoke Density: 45 or less.

2. Critical Radiant Flux: Class I - Minimum 0.45 watts per square centimeter. (Class II - Minimum 0.22 watts per square centimeter.)
- C. Slip Resistance: Static coefficient of friction for installed flooring shall be equal to or greater than .06 when measured with a James Machine per ASTM D2047.

1.5 PRODUCT HANDLING

- A. Comply with requirements of Section 01 6000 – Product Requirements.
- B. Delivery: Deliver materials to Project site in manufacturer's unopened containers clearly marked with manufacturer's name, brand, size, thickness, grade, color, graining, and design.
- C. Storage: Store materials per manufacturer's recommendations and at not less than 70 degrees F for at least 24 hours before installation.

1.6 PROJECT CONDITIONS

- A. Environmental Requirements: Maintain temperature in spaces to receive resilient flooring at 70 degrees F minimum at least 48 hours before, during, after installation; thereafter, maintain a 55 degrees F minimum.

PART 2 - PRODUCTS

2.1 GENERAL

- A. Basis-of-Design: Tile Products as scheduled on the Drawings provide a "Basis-of-Design" for each scheduled Resilient Flooring Product and have been selected and approved for use by the Owner based manufacturer's samples provided to the Architect, and have been fully coordinated with finish materials specified elsewhere.
- B. Resilient Flooring substitution requests will only be considered for acceptance by the Architect when the following conditions are met:
 1. Proposed substitution Resilient Flooring meets or exceeds the specified material, construction and performance criteria.
 2. Proposed Resilient Flooring substitution visually matches scheduled types for thickness, textures, patterns, color, and reflectance and other surface characteristics as determined by the Architect.
 3. Acceptance of a proposed substitution Resilient Flooring by the Architect shall incur no additional cost to the Owner, including

costs incurred to re-select adjacent finishes specified elsewhere as required to coordinate and match substituted Resilient Flooring for color, texture or pattern.

2.2 RESILIENT BASE AND ACCESSORIES

- A. Manufacturer: Provide products manufactured by Mannington.
- B. Adhesive for Resilient Bases: Waterproof type recommended in writing or supplied directly by base manufacturer.
- C. Resilient Base Materials: Thermoplastic Rubber, Type TP- Premium Edge wall base. Finish: Smooth Matte Finish. Corners- Factory pre-formed. Thickness- 1/8"; 4-foot minimum length.
 - 1. Provide colors as scheduled on Drawings and specified and as required to match Architect's samples.
 - 2. Provide manufacturer's standard black at casework bases.
- D. Resilient Base Types:
 - 1. Rubber Wall Base by Roppe
 - a. Color: As scheduled on Drawings.
 - b. Height: 4-inches.
 - c. Seal rubber base to resilient flooring with continuous clear silicon sealant.
- E. Locations: Provide resilient base at locations shown or scheduled on Drawings, including:
 - 1. Exposed, Sealed and Painted Concrete floors.
 - 2. Floors finished with materials specified in this Section.
 - 3. Plywood.

2.3 HOMOGENEOUS SHEET VINYL FLOORING

- A. General: Provide PVC-Free Resilient Sheet Flooring in conformance with ASTM F-1303, Type I, Grade 1, Class B Backing, for types, compositions, and other characteristics indicated.
 - 1. Manufacturer: Provide "**BIOSPEC MD**" by **Mannington** Commercial Flooring.

2. Homogeneous Vinyl Flooring Types:
 - a. As scheduled on Drawings.
- B. Performance Requirements:
 1. Fire Resistance: 450 or less when tested per ASTM E-662/NFPA 258 (Smoke Density). 0.45-watts/cm² or better (Class 1 or better) when tested per ASTM E-648/NFPA 253 (Critical Radiant Flux).
 2. Static Load Limit: 750-pounds per square inch or better when tested per ASTM F-970.
 3. Slip Resistance: equal or exceed specified requirements.
- C. Homogeneous Sheet Vinyl Flooring Accessories:
 1. Adhesive: Provide Solvent-free Adhesives recommended by each Homogeneous Sheet Vinyl Flooring Manufacture in writing for use with each type of specified Homogeneous Sheet Vinyl Flooring and for the actual conditions at the project area.
 - a. Adhesive Trowel: Use appropriate trowel tooth patterns as recommended by the Adhesive Manufacturer in writing for use with the specified Homogeneous Sheet Vinyl Flooring types.
 2. Sub-Floor Primer and Sealer: Provide sub-floor Sealers or Primers where recommended by the Resilient Sheet Flooring Manufacturer(s) in writing where required by the Sub-Floor conditions at the project area at the project area noted during verification of conditions.
 3. Welding Rods: For Homogeneous Sheet Vinyl Flooring shown on Drawings or scheduled to receive heat-welded seams, provide 4-mm welding rod as recommended in writing by the manufacturer of each specified type of Flooring. Provide single-sourcing of welding rods and sheet vinyl flooring for each specified type of Resilient Sheet Flooring.
 - a. Colors: Provide welding rods to match Architect's samples or as selected by Architect from manufacturer's full range of colors.
 4. Homogeneous Sheet Vinyl Flooring Initial Cleaning: Typical at all locations, follow Resilient Sheet Flooring manufacturer's written

instructions recommending process and product for each specified type.

- a. Finish Sheen: to be Matte.

2.4 LUXURY VINYL PLANK

~~A. General: Provide Luxury Vinyl Tiles and Planks in conformance with ASTM F-1700, Class 3, Type B for types, compositions, and other characteristics indicated.~~

~~1. Manufacturer:~~

~~a. Provide 6" x 36" LVP "**NATURE'S PATHS**" by **Mannington** Commercial Flooring.~~

~~2. Luxury Vinyl Plank Types:~~

~~a. As scheduled on Drawings.~~

~~B. Performance Requirements:~~

~~1. Fire Resistance: 450 or less when tested per ASTM E-662/NFPA 258 (Smoke Density). 0.45-watts/cm² or better (Class 1 or better) when tested per ASTM E-648/NFPA 253 (Critical Radiant Flux).~~

~~2. Static Load Limit: 750 pounds per square inch or better when tested per ASTM F-970.~~

~~3. Slip Resistance: equal or exceed specified requirements.~~

~~C. Luxury Vinyl Plank Accessories:~~

~~1. Adhesive: Provide Solvent-free Adhesives recommended by the Luxury Vinyl Plank Manufacturer(s) in writing for use with each type of specified Vinyl Composition Tile and for the conditions at the project area.~~

~~a. Adhesive Trowel: Use appropriate trowel tooth patterns as recommended by the Adhesive Manufacturer in writing for use with the specified Luxury Vinyl Plank types.~~

~~2. Sub-Floor Primer and Sealer: Provide sub-floor Sealers or Primers where recommended by the Luxury Vinyl Plank Manufacturer(s) in writing where required by the Sub-Floor conditions at the project area at the project area noted during verification of conditions.~~

~~3. ——— Luxury Vinyl Plank Sealer: Typical at all locations, provide sealer coat for Luxury Vinyl Plank floors as recommended by each Luxury Vinyl Plank manufacturer in writing for each specified type.~~

~~————— 4. ——— Wax for Luxury Vinyl Plank: not recommended.~~

2.7 MATERIALS FOR COVERED BASE AT RESILIENT FLOORS

A. General: Provide materials as required to install cove base at locations shown or scheduled on Drawings. Not all specified resilient sheet flooring types may require cove base; some resilient flooring types may be scheduled to receive several base treatments, including cove base.

B. Materials:

1. Fillet Cove Strips: Provide redwood cove strips as recommended by each specified resilient sheet flooring manufacturer in writing to coordinate with each specified resilient sheet flooring type.
2. Outside Corner for Resilient Sheet Covered Base: Provide the each specified manufacturer's outside pre-molded corner to match each specified resilient sheet flooring type. Provide types and color(s) as scheduled on Drawings and as specified.
3. Cap Strip: Extruded aluminum, clear anodized. Single-source one cap strip type and finish for use through-out entire scope of project. Provide cap strips in the longest length practical to minimize butt joints.

2.8 REDUCER STRIPS, EDGE STRIPS AND TRANSITIONS

A. Manufacturer: Where Manufacturer's standard products are scheduled on Drawings and specified, provide the specific products indicated or materials complying with the requirements set forth in this Section.

B. Adhesive for reducer, edge and transition strips: Waterproof type recommended in writing or supplied directly by base manufacturer.

C. Locations: Provide reducer, edge and transition strips at locations where different floor finishes meet, as required to protect the transition joint and/or provide a gentle transition between floor finishes of differing thicknesses, including:

1. Exposed, Sealed and Painted Concrete floors: to any other floor finish.
2. Section 093000 – Tile: to any floor finish specified in this Section and Section 096813 – Tile Carpeting.

3. Floor finishes specified in this Section:
 - a. All locations between two different floor finish materials specified in this Section.
 - b. Between two different floor finish colors of the same material specified in this Section when shown or scheduled on Drawings.
 - c. Between floor finishes specified in this Section and at transitions to carpet specified in Section 096813 – Tile Carpeting.
- D. Manufacturer: Provide reducer, edge and transition strips by Johnsonite, Mercer, or approved equal.
 1. Provide reducer, edge and transition strips at all level differences in flooring. Center on door frame where possible.
 - a. Colors: As selected by the Architect from the manufacturer's full range of standard colors.

PART 3 - EXECUTION

3.1 EXAMINATION

- A. Verification of Conditions: Examine substrates and adjoining construction and conditions under which Work will be installed. Give written notification of deficiencies detrimental to proper or timely installation; do not proceed until corrected.
- B. Slab Moisture Test:
 1. General: Test substrates to determine acceptable dryness prior to application of resilient flooring. Use ASTM F-1869-89, "Standard Test Method for Measuring Moisture Vapor Emission Rate of Concrete Subfloor Using Anhydrous Calcium Chloride", as applicable for the specified flooring as recommended by resilient flooring manufacturer.
 2. Slab-Moisture Content Testing: Perform tests at locations not more than 50 feet apart in every direction, but no less than one test per 1000-square feet. Verify the following performance criteria are equaled or exceeded before beginning floor installation:

- a. Vapor and moisture barrier shall reduce vapor transmissions from concrete slabs-on-grade and above-grade concrete and metal deck assemblies to 3 pounds or less per 1000-square feet in a 24-hour period when tested per ASTM F-1869-89.
 - b. Alkalinity: Maximum pH of 10.
 3. Contingency for High Moisture Readings: Report all unacceptable test results to Architect.
- C. Air-Moisture Content Testing:
 1. General: Determine relative humidity of air in rooms to receive resilient flooring, using wet-bulb and dry-bulb sling psychrometer. Do not install resilient flooring when relative humidity exceeds 45 percent.
- D. Adhesion Test:
 1. Secure one, three-foot-square piece of each specified type of resilient sheet or 3-foot by 3-foot area of each specified type of tile in each typical area that has passed the specified moisture test, using adhesive(s) as specified and recommended by manufacturer(s).
 2. The test pieces shall remain in place for 72 hours.
 3. Determine if the adhesive is bonding the material satisfactorily to the surface. Resilient flooring should not be able to be removed without severe deformation, tearing, or destruction of the sample(s).
 4. Where there is evidence of unsatisfactory bonding, manufacturer's representative is to be notified in order that they may verify and evaluate the conditions.
 5. Notify Architect immediately if, in the opinion of manufacturer's representative, the adhesion test results are unsatisfactory.
 6. Remove successful test pieces and adhesive prior to commencing final installation.

3.2 PREPARATION

- A. Surface Preparation: Clean substrate of deleterious materials which impair bonding of resilient flooring. Do Work on smooth, even troweled finish. Remove rough areas and protrusions from concrete by gridding.

Fill cracks, rough areas, and other surface defects with an acceptable plastic filler.

- B. Primer/Sealer Coat: Apply primer to concrete surfaces; work well into surfaces; use minimum quantity that will assure complete surface coverage with a non-absorptive base. Allow primer to thoroughly dry before applying adhesive.
 - 1. Prime coat may be omitted if recommended by resilient flooring manufacturer in writing based on review of the project area. Review the requirements for each specified type of resilient flooring for each project area.
 - 2. Do not combine different specified flooring types under one manufacturer's recommendation.

3.3 INSTALLATION

- A. Edge Strips:
 - 1. General: Install in continuous lengths at door openings and other exposed edges of resilient flooring, unless otherwise shown. Install edge strips before applying primer.
 - 2. Metal: Anchor strips solidly to substrate with countersunk non-magnetic stainless steel screws; use lead shields for anchoring into concrete; space screws 1-inch from each end and not more than 9-inch centers at intermediate points.
 - 3. Vinyl: Set in and securely bond to substrates with adhesive per manufacturer's recommendations.
- B. Prime Coat: Apply primer to concrete surfaces; work well into surfaces; use minimum quantity that will assure complete surface coverage with a non-absorptive base.
 - a. Allow primer to thoroughly dry before applying adhesive.
 - b. Prime coat may be omitted if recommended by resilient flooring manufacturer.
- C. Adhesive: Apply to substrate with properly notched steel trowels; allow adhesive to become tacky before applying resilient flooring.
- D. Resilient Flooring: Extend flooring, and fit neatly and tightly, into breaks and recesses, against bases, around pipes and penetrations, around permanent casework, equipment, and under-casework recesses.

E. Sheet Material:

1. General: Lay sheet material with minimum number of joints with bottom surface securely bonded to substrate and top surface left smooth, clean, and free from imperfections.
 - a. Make joints straight, tight, and inconspicuous.
 - b. Roll each sheet from center to edges to assure complete bond and tight joints.
2. Joints: Provide Chemically Weld; Adhesive Weld; Heat Weld as scheduled on Drawings and in conformance with sheet flooring manufacturer's written instructions.
3. Distance between seams to be eight feet minimum. Provide shop drawings showing seam locations for approval before installation.
4. Coved Bases:
 - a. Install a continuous redwood cove strip at intersection of floor and vertical surfaces prior to laying sheet material.
 - b. Use cove strip with a 3/4-inch radius; make bases 4 inches high, unless otherwise shown; butt ends; miter corner; secure with acceptable type fasteners.
 - c. Apply cove strips and sheet material to solid backing.
 - d. Roll sheet material into adhesive; hold in place until complete adhesion is assured. **DO NOT USE DOUBLE STICK TAPE FOR THIS APPLICATION. BASE TO BE FULLY ADHERED TO WALL WITH GLUE TYPE ADHESIVE.**
 - e. Make top of base level and straight; terminate top edge into a metal trim cap.
 - f. Securely screw trim cap to backing before applying sheet material; use single lengths where possible; make neat mitered corners and butted ends.
 - g. Use standard aluminum alloy or stainless steel trim cap of standard design as selected, unless otherwise shown.
4. Perimeter Bond System: At Contractor's option, a perimeter bond system may be used for installation of sheet vinyl flooring.

- a. Do work with manufacturer's approved and trained applicators per manufacturer's recommendations and supervision.
- b. Install sheet vinyl flooring with adhesive spread only at seam lines, projections, and wall lines.
- c. Cut seams with an electrically operated cutting machine made for purpose.

F. Resilient Bases:

1. General: Where base is scheduled, install around perimeter of room or space, at base of partitions, walls, columns, pilasters, casework, and other permanent fixtures.
 - a. Install top-set coved type bases throughout, except install straight type bases at carpet.
 - b. Secure bases to surfaces with waterproof adhesive; make joints tight; keep top and bottom edges in firm contact with adjacent surfaces.
 - 1) Provide a continuous seal of the resilient base to both the wall surface at the upper edge and the floor surface at the bottom edge.
 - c. Use longest lengths possible; straight pieces less than 24 inches long not permitted.
 - d. Miter or cope inside corners.
2. Coved Type: Provide with premolded end stops and premolded one-piece external corners.
3. Straight Type: Provide with preformed one-piece external corners.
4. Edges and Seams: Match edges at seams. Double cut adjoining lengths. Make tight butt joints.

3.4 CLEANING

- A. General: Not more than four days before Substantial Completion, thoroughly clean work per resilient flooring manufacturer's recommendations. Use of solvents, wet mopping, or washing is prohibited.

- B. Defective and Damaged Work: Replace with acceptable Work at no additional cost to Owner.

3.5 PROTECTION

- A. General: Protect Work from traffic during construction period so Work will be without indication of use or damage at time of Substantial Completion.

SECTION 09 68 13 – CARPET TILE

PART 1 - GENERAL

1.1 SUMMARY

- A. Furnish labor, materials, tools, equipment, and services for Carpet Tile (CPTT) in accordance with provisions of the Contract Documents.
- B. Completely coordinate with work of other trades.

1.2 QUALITY ASSURANCE

- A. Manufacturer Qualifications:
 - 1. Carpet manufacturer shall have no less than ten (10) years of production experience with carpet similar to type specified in this document; and whose published product literature clearly indicates compliance of products with requirements of this section.
- B. Contractor Qualifications:
 - 1. Firm with not less than five (5) years of successful carpeting experience similar to work of this section and recommended and approved by the carpet manufacturer. Upon request, submit letter from carpet manufacturer stating certification qualifications and acceptance.
- C. Installer Qualifications:
 - 1. Mill trained, skilled mechanics supervised by experienced superintendent with 50,000 yards experience.
- D. Single Source Responsibility:
 - 1. Provide product material by a single manufacturer for each carpet type specified.
- E. Carpet and Rug Institute:
 - 1. CRI-104 Standard for Installation of Commercial Carpet.
 - 2. CRI Green Label program.

1.3 SUBMITTALS

- A. Samples:
 - 1. Three samples 12 IN square of each material and color specified in Drawing I-001 Interior Finish Schedule.
- B. Contract Closeout Information:
 - 1. Warranty.
 - 2. Maintenance data:
 - a. See Section 01 78 23.

1.4 WARRANTY

- A. Written warranty for replacement of damaged or defective carpet or carpet stained by adhesives for a period of two (2) years.
- B. Written warranty that material will not significantly degrade for a period of fifteen (15) years due to the following:
 - 1. Exposure to normal light shall not affect colorfastness as measured by AATCC 16E.

2. Exposure to normal atmospheric contaminants.
 3. Excessive wear resulting in reduction of pile height by more than 15 percent in any area or pulling out of nap.
 4. Delamination from face structure and shrinkage or stretching affecting performance of face or backing structure or causing tile to curl or dome.
 5. Edge ravel.
- C. Warranty to include removal, replacement, and disposal of defective carpet.

PART 2 - PRODUCTS

2.1 ACCEPTABLE MANUFACTURERS

- A. Carpet Tile : As indicated on Interior Finish Schedule. Data sheets at the end of this spec section.
1. Base:
 - a. Broadloom base to match carpet in room or as specified.
- B. Other manufacturers desiring approval comply with Section 00 26 00.

2.2 MATERIALS

- A. Carpet Tile:
1. First quality, no seconds or imperfections.
 2. Deliver with mill register numbers attached.
 3. Comply with applicable state and local codes.
 4. Antimicrobial;
 - a. Broad spectrum efficacy against bacteria and fungus for the life of the product.
 5. Carpet installed in the building interior shall comply with the testing and product requirements of the California Department of Public Health Standard Method for the Testing and Evaluation of Volatile Organic Chemical Emissions From Indoor Sources Using Environmental Chambers version 1.1 (CDPH/EHLB Standard Method v1.1), modeled using the standard office building protocol parameters and certified as compliant by an independent third party.
- B. Carpet Edging Strips and Carpet Base:
1. Thickness to match carpet.
 2. Color to match carpet tile/base.
- C. Adhesive:
1. Base: Full spread N5100 Pressure Sensitive adhesive by Shaw Contract.
 2. Carpet adhesive shall have VOC content of no greater than 50 g/L.
 3. Carpet adhesives shall contain no carcinogen or reproductive toxicant components present at more than 1 percent of total mass of the product as defined in the California Office of Environmental Health Hazard Assessment's (OEHHA) list entitled Chemicals Known to the State to Cause Cancer or the Reproductive Toxicity, Safe Drinking Water and Toxic Enforcement Act of 1986 (Proposition 65).

2.3 EXTRA MATERIAL

- A. Furnish Owner with minimum of five (5) percent additional material of each type, pattern and color for maintenance purposes.

PART 3 - EXECUTION

3.1 EXAMINATION

- A. Verify suitability of substrate to accept installation.
- B. Verify concrete floor surfaces are suitable for Carpet Tile installation.
 - 1. Coordinate installation with requirements of Section 07 16 04 Concrete Floor Moisture Testing, and Section 07 16 05 Water Vapor Emission Control System.

3.2 PREPARATION

- A. Thoroughly clean areas to receive carpet tile, strip waxes and finishes.
- B. Thoroughly remove dust and vacuum, wet mop then seal concrete.
- C. Patching Compound :
 - 1. Fill cracks, joints, holes or uneven areas with non-crumbling latex base floor filler.
 - 2. Acceptable Product: Lev-L-Astic.
 - 3. Do not mix with water.
- D. Prior to commencement of work, test area with adhesive and carpet tile to determine open time and bond.
- E. Layout:
 - 1. Arrange joints symmetrically about centerline of rooms.
 - 2. Lay so pile and pattern of adjacent pieces match.
 - 3. Verify dimensions.

3.3 INSTALLATION

- A. General:
 - 1. Comply with manufacturer's instructions and recommendations for uniformity of direction, seam locations, and lay of carpet pile.
 - 2. Install carpet under open bottom obstructions and under removable flanges and furnishings, and into alcoves and closets of each space.
 - 3. Provide cut outs where required.
 - a. Conceal cut edges with protective edge guards or overlapping flanges.
 - 4. Run carpet under open-bottom items such as heating convectors.
 - 5. Install tight against walls, columns, cabinets and over recessed door closers.
 - 6. Install edge guard at openings and doors wherever carpet terminates, unless indicated otherwise.
 - 7. Make clean cuts in accordance with manufacturer's recommendation.
 - 8. Butt edges to produce tightest joint possible without distortion.
 - 9. Fill or level floors at uneven areas with leveling compound and feather minimum 4 FT- 0 IN.
 - 10. Where carpet tiles abut thicker finish flooring materials, feather leveling compound for approximately 12 IN for each 1/8 IN of rise so finished surfaces align.
 - 11. Expansion joints:
 - a. Do not bridge building expansion joints with continuous carpeting.
 - b. Provide for movement.
- B. Install in accordance with manufacturer's instructions.
 - 1. Adhesive must have recommended flash time before carpet is positioned.
 - 2. Do not mix dye lots in same area.
 - 3. Install carpet tiles with arrows pointing in same direction.

- C. Install carpet edging strips, transition strips, reducer strips, at non-carpeted floor surface.
 - 1. Install with contact adhesive.
 - 2. Score and trim narrow end of reducer strip to conform to adjacent floor finish.
- D. Install according to Architect's directions for overall patterns and borders.
 - 1. Install carpet patterns according to drawings without deviation.
 - 2. Develop templates as required.

3.4 CLEAN

- A. Remove spillage of adhesive from face or seam using remover provided by manufacturer.
- B. Remove loose threads with broadloom scissors.
- C. Remove spots.
- D. Completely and thoroughly vacuum using pile lifter.
- E. Save cuts over 9 IN for Owner stock.
- F. Advise Owner regarding care and maintenance.

3.5 PROTECTION

- A. Protect carpet subject to traffic with nonstaining building material paper runners or other approved material.
- B. Protect installation from rolling traffic with sheets of hardboard or plywood.
- C. Maintain carpet protection on each floor or area until accepted.

3.6 INSPECTION

- A. Inspect installation and verify work is complete and properly installed.

stipple tile

product type:	carpet tile	
collection:	Hand Drawn	
style number:	5T116	
construction:	multi-level pattern cut/loop	
fiber:	eco solution q® nylon	
dye method:	100% solution dyed	
primary backing:	synthetic	
secondary backing:	ecoworx® tile	
protective treatments:	ssp® shaw soil protection	
warranty:	lifetime commercial limited	
	u.s.	metric
product size:	18.0 x 36.0 inches	45.7 x 91.4 cm
gauge:	1/12 inch	47.2 per 10cm
stitches:	9 per inch	35 per 10cm
finished pile thickness:	0.108 inches	2.74 mm
average density:	6667 per cu.yd.	0.247 g/cm3
kilotex:		10.17 kilotex
total thickness:	0.255 inches	6.48 mm
tufted weight:	20.0 oz/yd2	678.1 gms/sqm



recommended installation method

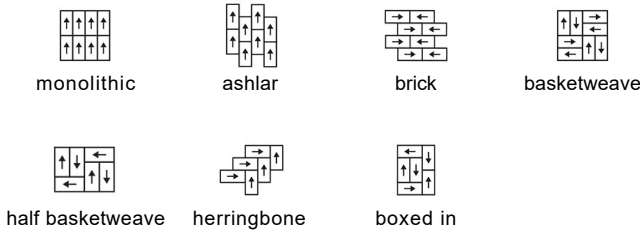

coordinating products

broadloom: **conte', erase, scribe, stylus**
 carpet tile: **fine point tile, lineweight tile**

performance + testing

antimicrobial assessment:	passes (AATCC-174) (When installed using Shaw 5036 adhesive)
pill test:	pass
radiant panel:	class I
nbs smoke:	less than 450
electrostatic propensity:	less than 3.5 kv
CRI greenlabel plus:	USA (GLP9968)

product transparency

Shaw Contract is dedicated to providing clients with a building chemistry that's safe and dependable. Working together, we will help you meet your goals as they pertain to material health. EcoWorx products with Eco Solution Q nylon are Cradle to Cradle Certified (tm) Silver and assessed for impacts on human health and the environment. This product can be recycled. When it's time to replace, we can collect and recycle it through our Environmental Guarantee.*

attributes + certifications

Cradle to Cradle Certified™	silver level (version 3.1)
Health Product Declaration (HPD):	1,000 ppm disclosure
Environmental Product Declaration (EPD):	3rd party certified in accordance with ISO14044, ISO14025 & EN15804
Living Building Challenge (LBC):	free of red list chemicals
Declare:	LBC compliant
nsf 140:	gold
CRI Green Label Plus (GLP):	USA (GLP9968)
Building Research Establishment (BRE):	certified
Good Environmental Choice Australia (GECA):	certified
Singapore Green Label:	039-003
ce marking (EN 14041):	3rd party certified
environmental guarantee*:	free pickup & delivery available north america
total recycled content:	44% (post industrial 44% post consumer 0%)
product packaging:	100% recyclable
country of origin**:	USA

green leed contribution credit

MR Credit: Building Product Disclosure and Optimization Environmental Product Declarations - Option 1. Environmental Product Declaration (EPD)	3rd party certified in accordance with ISO14044, ISO14025 & EN15804
MR Credit: Building Product Disclosure and Optimization Material Ingredients - Option 1: Material Ingredient Reporting	HPD (version 2.1) or C2C silver level (version 3.1)
MR Credit: Building Product Disclosure and Optimization Material Ingredients - Option 2: Material Ingredient Optimization	C2C silver level (version 3.1)
MR Credit: Building Product Disclosure and Optimization Sourcing of Raw Materials - Option 2: Leadership Extraction Practices	environmental guarantee: free pickup & delivery available north america
EQ Credit: Low Emitting Materials Option 1. Product Category Calculations	green label plus certification: GLP9968
MR Credit: Interiors Life-Cycle Impact Reduction Option 3. Design for Flexibility	ecoworx tile w/ lokdots installation system

additional information

* To learn more about the recyclability of our products and our Environmental Guarantee, please visit shawcontract.com.

**Meets or exceeds all local and national regulations in country of manufacture.



Specifications are subject to nominal manufacturing variances. Material supply and/or manufacturing processes may necessitate specification changes without notice. This carpet is an exclusive design and may not be duplicated in any manner. Use of this design in the creation of another carpet design is also strictly prohibited. Visit shawcontract.com/testing for more information.

Corporate Headquarters +1 800 257 7429 | +1 706 532 7984 | **Atlanta** +1 404 853 7429 | **Bangalore** +9180 6759 0334 x 0335 | **Beijing** +86 10 6568 5881 | **Chicago** +1 312 467 1331 | **Dubai** +971 4 313 2496 | **Hong Kong** +852 2623 0371 | **Latin America (Miami)** +1 305 827 5912 | **London** +44 207 961 4120 | **Los Angeles** +1 800 239 1614 | **Melbourne** +1 800 556 302 | **Mexico City** +55 5010 7600 | **Nantong** +86 400 800 7429 | **New York** +1 212 953 7429 | **San Francisco** +1 415 955 1920 | **Santiago** +562 2431 5000 x 550 | **Shanghai** +86 21 5258 9799 | **Singapore** +65 6733 1811 | **Sydney** +1 800 556 302

form tile

product type:	carpet tile	
collection:	Noble Materials	
style number:	5T136	
construction:	multi-level pattern cut / loop	
fiber:	eco solution q® nylon	
dye method:	100% solution dyed	
primary backing:	synthetic	
secondary backing:	ecoworx® tile	
protective treatments:	ssp® shaw soil protection	
warranty:	lifetime commercial limited	
	u.s.	metric
product size:	24.0 x 24.0 inches	61.0 x 61.0 cm
gauge:	1/10 inch	39.4 per 10cm
stitches:	8 per inch	32 per 10cm
finished pile thickness:	0.149 inches	3.78 mm
average density:	6765 per cu.yd.	0.251 g/cm3
kilotex:		7.48 kilotex
total thickness:	0.299 inches	7.59 mm
tufted weight:	28.0 oz/yd2	949.4 gms/sqm



recommended installation method



coordinating products

broadloom: **monolith woven, base metal woven, strata, fault**
 carpet tile: **slab tile, honed tile, alchemy tile**

performance + testing

antimicrobial assessment:	passes (AATCC-174) (When installed using Shaw 5036 adhesive)
pill test:	pass
radiant panel:	class I
nbs smoke:	less than 450
electrostatic propensity:	less than 3.5 kv

product transparency

Shaw Contract is dedicated to providing clients with a building chemistry that's safe and dependable. Working together, we will help you meet your goals as they pertain to material health. EcoWorx products with Eco Solution Q nylon are Cradle to Cradle Certified (tm) Silver and assessed for impacts on human health and the environment. This product can be recycled. When it's time to replace, we can collect and recycle it through our Environmental Guarantee.*

attributes + certifications

Cradle to Cradle Certified™	silver level (version 3.1)
Health Product Declaration (HPD):	1,000 ppm disclosure
Environmental Product Declaration (EPD):	3rd party certified in accordance with ISO14044, ISO14025 & EN15804
Living Building Challenge (LBC):	free of red list chemicals
Declare:	LBC compliant
nsf 140:	gold
CRI Green Label Plus (GLP):	USA (GLP9968) China (GLP1263)
Building Research Establishment (BRE):	certified
Good Environmental Choice Australia (GECA):	certified
Singapore Green Label:	039-003
ce marking (EN 14041):	3rd party certified
environmental guarantee*:	free pickup & delivery available north america
total recycled content:	40% (post industrial 40% post consumer 0%)
product packaging:	100% recyclable
country of origin**:	China & USA

green leed contribution credit

MR Credit: Building Product Disclosure and Optimization Environmental Product Declarations - Option 1. Environmental Product Declaration (EPD)	3rd party certified in accordance with ISO14044, ISO14025 & EN15804
MR Credit: Building Product Disclosure and Optimization Material Ingredients - Option 1: Material Ingredient Reporting	HPD (version 2.1) or C2C silver level (version 3.1)
MR Credit: Building Product Disclosure and Optimization Material Ingredients - Option 2. Material Ingredient Optimization	C2C silver level (version 3.1)
MR Credit: Building Product Disclosure and Optimization Sourcing of Raw Materials - Option 2: Leadership Extraction Practices	environmental guarantee: free pickup & delivery available north america
EQ Credit: Low Emitting Materials Option 1. Product Category Calculations	green label plus certification: GLP9968
MR Credit: Interiors Life-Cycle Impact Reduction Option 3. Design for Flexibility	ecoworx tile w/ lokdots installation system

additional information

* To learn more about the recyclability of our products and our Environmental Guarantee, please visit shawcontract.com.

**Meets or exceeds all local and national regulations in country of manufacture.



Specifications are subject to nominal manufacturing variances. Material supply and/or manufacturing processes may necessitate specification changes without notice. This carpet is an exclusive design and may not be duplicated in any manner. Use of this design in the creation of another carpet design is also strictly prohibited. Visit shawcontract.com/testing for more information.

Corporate Headquarters +1 800 257 7429 | +1 706 532 7984 | Atlanta +1 404 853 7429 | Bangalore +9180 6759 0334 x 0335 | Beijing +86 10 6568 5881 | Chicago +1 312 467 1331 | Dubai +971 4 313 2496 | Hong Kong +852 2623 0371 | Latin America (Miami) +1 305 827 5912 | London +44 207 961 4120 | Los Angeles +1 800 239 1614 | Melbourne +1 800 556 302 | Mexico City +55 5010 7600 | Nantong +86 400 800 7429 | New York +1 212 953 7429 | San Francisco +1 415 955 1920 | Santiago +562 2431 5000 x 550 | Shanghai +86 21 5258 9799 | Singapore +65 6733 1811 | Sydney +1 800 556 302

SECTION 09 78 13 - INTERIOR MODULAR METAL WALL PANEL SYSTEM (MWPS)**PART 1 - GENERAL****1.1 SUMMARY**

- A. Furnish labor, materials, tools, equipment, and services for Interior Modular Metal Wall Panel System, as indicated, in accordance with provisions of Contract Documents.
- B. Section Includes:
 - 1. Stainless steel modular wall panels for Operating Rooms.
- C. Coordinate with work of other trades.
 - 1. Coordinate locations with other work to prevent interference with clearances required for access by disabled persons, proper installation, adjustment, operation, cleaning, and servicing of accessories.
 - 2. Deliver inserts and anchoring devices set into concrete or masonry as required to prevent delaying the Work.
 - 3. Coordinate with mechanical and electrical requirements.
 - 4. Schedule installation of medical equipment in each room or space such that construction activity of other trades is essentially complete prior to commencement.

1.2 QUALITY ASSURANCE

- A. Source Limitations: Provide products of same manufacturer for each type of medical equipment exposed to view in same areas, unless otherwise approved by Architect.
- B. ASTM Standards:
 - 1. ASTM A666 Standard Specification for Annealed or Cold-Worked Austenitic Stainless Steel Sheet, Strip, Plate and Flat Bar
 - 2. ASTM B221 Standard Specification for Aluminum and Aluminum-Alloy Extruded Bars, Rods, Wire, Profiles, and Tubes
 - 3. ASTM C1177/C1177M Standard Specification for Glass Mat Gypsum Substrate for Use as Sheathing
 - 4. ASTM C1396/C1396M Standard Specification for Gypsum Board
 - 5. ASTM C1658/C1658M Standard Specification for Glass Mat Gypsum Panels
 - 6. ASTM D3273 Standard Test Method for Resistance to Growth of Mold on the Surface of Interior Coatings in an Environmental Chamber
 - 7. ASTM E84 Standard Test Method for Surface Burning Characteristics of Building Materials
- C. LEED Requirements:
 - 1. Refer to Section 01 81 17, LEED HC v4 Requirements, for additional performance requirements that may apply to products specified in this section.

1.3 SUBMITTALS

- A. Shop Drawings:
 - 1. Detailed drawings showing each component of system in plan and elevation, indicating dimensions and details of construction, installation, and interface with related services.
 - 2. Manufacturer shall review shop drawings with hospital staff to verify locations and "handling" of or installation of equipment.
- B. Product Data:
 - 1. Manufacturer's literature indicating construction details, material descriptions and

thicknesses, profiles, fastening and mounting methods, specified options, and finishes for each type of accessory specified, and fire test information in compliance with specifications.

2. Material Certificates: Submit certification materials have been tested and comply with specified requirements.

C. Samples:

1. Two 8 IN x 4 IN pieces of exposed components in specified finish.

Cl. Contract Closeout Information:

1. Maintenance data:
 - a. See Section 01 78 23.
 2. Interior finish fire performance data:
- a. Provide for each finish material and type specified:
- 1) Manufacturer's printed information including:
 - a) Fire class.
 - 2) See Section 01 78 26.

1.4 DELIVERY, STORAGE AND HANDLING

- A. Coordinate the delivery and installation of this work with the Contractor's schedule.
- B. Inspect materials upon delivery. Replace any panels or components damaged during shipment, storage, or handling with new identical factory-supplied components.
- C. Protect finishes from physical damage by leaving factory packing cases in place before installation and providing temporary protective covers after installation with on-going construction within the Project area.

PART 2 - PRODUCTS

2.1 MANUFACTURERS

1. Modular Metal Wall System:
 1. mfPHD, LLC (contact: Tom Crenshaw 254-717-0133, tcrenshaw@mfphd.com).
 2. Made in the U.S.A.
2. Other manufacturers desiring approval shall comply with Section 00 26 00.

2.2 PERFORMANCE REQUIREMENTS

1. Design and construct panels to meet requirements as indicated.
 1. Surface Burning Characteristics: Panels shall have been tested in accordance with ASTM E84 for surface burning characteristics. Panels shall have a flame spread of <10 and smoke developed of ≤ 25 for Class A fire rated.
 2. Adjustability: Finished panels must be able to accommodate the increase or decrease in width, due to variations between plan and field dimensions, while maintaining all original properties.

2.3 MATERIALS

1. Stainless Steel Sheet: ASTM A666, Type 304, stretcher-leveled standard of flatness, polished to No.4 Finish and/or Powder Coat Finish, 1.22mm thick.
2. Interior Gypsum Board:
 1. 5/8 IN Type X moisture- and mold-resistant panels for use on walls. Comply with ASTM C1177, C1396, C1658 and D3273.

2. Products:
 - a. USG Sheetrock Brand Mold Tough Panels Firecode X.
 - b. USG Brand UltraLight Panels Mold Tough Firecode X.
 - c. Georgia-Pacific ToughRock Fireguard X Mold-Guard Gypsum Board.
3. Aluminum Extrusions: ASTM B221/B221M, with alloy and temper required to suit structural and finish requirements.
4. Gasket: EPDM – ethylene propylene diene monomer (M-Class) rubber.
 1. Finish: As selected by Architect from manufacturer's full range of finishes.

2.4 FABRICATION

1. Wall Panels:
 1. Panels: Adhere stainless steel face sheets to Type X moisture & mold resistant gypsum board.
 2. Edges: All edges of the panel are returned back to cover the gypsum. The vertical seams are returned back to cover the panel and then turned to create a fastening flange.
 3. Corners and Angles: All inside and outside are solid piece construction. 90's, 45's, 22.5 degree angles are formed out of a single panel to eliminate corner joints. Any angle is possible.
 4. Gasket: Push in manually between panels to create a water tight seal.
 5. Adjustability: Finished panels must be able to accommodate the increase or decrease in width, due to variations in the field between plans and field dimensions, while maintaining all original properties.
2. Windows:
 1. Glass: 6mm safety glass.
 2. Frame: 14 gauge stainless steel.
 3. Integral Blinds: tilt for privacy or viewing and completely retract.
 4. Control: Control buttons are located by owner
 5. Lead: Lead value to be determined by owner/physicists specification
3. Cabinets:
 1. Material: Walls, shelves and doors are 1mm 304 stainless steel wrapped around a corrugated honeycomb core. Sandwich panel design.
 2. Door glass: 6mm safety glass
 3. Hinges: Concealed hinge design

PART 3 - EXECUTION

3.1 EXAMINATION

- A. Verification of Conditions: Examine areas and conditions under which work is to be performed and identify conditions detrimental to proper or timely completion. Do not proceed until unsatisfactory conditions have been corrected.
- B. If support system preparation is the responsibility of another installer, notify Architect of unsatisfactory preparation before proceeding.
- C. Start of installation indicates acceptance of responsibility for performance.

3.2 INSTALLATION

- A. Install in accordance with manufacturer's written instructions and industry standards.

- B. Fasteners according to manufacturer's recommendations and installer.
- C. Form panel shape as indicated on Drawings, accurate in size, square, and free from distortion or defects.
- D. Install gaskets and trim true and in proper alignment.
- E. Utilize standard stud framing for installation

3.3 FIELD QUALITY CONTROL

- A. Installer shall make periodic inspections and issue report to Architect regarding compliance with manufacturer's installation recommendations developed for the project.

3.4 ADJUSTING AND CLEANING

- A. Repair damage caused during construction.
 - 1. Touch-up mars, scratches, and cut edges to match original finish.
 - 2. If repairs cannot be made to comply with Architect's requirements, remove damage panels and install new panels.
- B. Wipe finished surfaces clean of any filings caused by drilling or cutting to prevent rust staining.
- C. Clean entire surface again prior to closeout.

END OF SECTION

SECTION 09 91 23- INTERIOR PAINTING

PART 1 - GENERAL

1.1 SUMMARY

- A. Work Included: Interior and Exterior Painting, complete as shown on Drawings and as specified.
1. Work includes, but is not limited to, painting of following items, materials, and spaces:
 - a. Paint every interior and exterior exposed-to-view unfinished surface, except as otherwise shown on Drawings or as specified.
 - b. Paint the following exposed mechanical and electrical items to match adjacent surfaces even if the items are factory-finished:
 - 1) Wall and ceiling diffusers/registers installed in gypsum board assemblies at any location.
 - 2) Access doors at any location except when concealed above suspended ceilings.
 - 3) Flush-mounted electrical panelboards and cabinets in gypsum board assemblies at any location.
 - 4) All exposed piping, conduit, duct work and similar surfaces in Stair Enclosures and Fire Control Room (except items with factory "red" finish).
 - c. Paint semi-visible areas behind registers, grilles, diffusers, screen vents as required to "black out".
 - d. Paint auxiliary rails of smoke containment screens with high-temperature coating.
 - e. Stairs: Paint all exposed ferrous metal assemblies, concrete landings and treads, including hazard striping as required by code.
 - f. Stenciling at Smoke Partition and Fire Rated Walls: See section 092900 Gypsum Board.
 2. Do not paint the following items:
 - a. Factory-finished items specified in various Sections.
 - b. Pre-finished wall, ceiling, and floor coverings.
 - c. Concrete traffic or walking decks, walks, steps, and ramps.

- d. Code-Required Labels: Keep equipment identification and fire rating labels free of paint.
 - e. Surfaces concealed in walls and above ceilings except as specifically indicated otherwise.
 - f. Ducts, piping, conduit, and equipment concealed in walls and ceilings, unless specifically indicated otherwise.
 - g. Do not paint "Shell Areas" as shown on drawings except paint all sides of doors and frames at walls into finished areas.
 - h. Mechanical or elevator shafts not requiring periodic cleaning.
 - i. Mechanically-finished nonferrous metal, such as stainless steel, aluminum, and bronze, except exposed mechanical and electrical items.
 - j. Interior spaces specifically noted as unpainted.
3. Note: This Section includes a comprehensive listing of paint finish types. Not all paint systems included herein may be required by the Scope of Work of this Project, or the scope of some finishes may be very limited. The responsibility of the Contractor to schedule the Work so that all specified and required Painting Scope is included in the Scope of Work for the Project.
- B. Work Specified Elsewhere:
- 1. Section 050500 – Metal Fasteners.
 - 2. Section 079200 – Joint Sealants.
 - 3. Section 099113 – Exterior Painting.

1.2 SUBMITTALS

- A. Comply with requirements of Section 013300 – Submittal Procedures.
- B. Product Data: Submit complete list of materials proposed for use, together with manufacturer's data and specifications.
- C. Samples:
 - 1. Opaque Colors and Finishes: Submit samples, on hardboard, using materials accepted for Project, of each color and paint finish selected with texture to simulate actual conditions. Prepare three samples, 8-1/2 inches by 11 inches, with required number of paint coats clearly visible.
 - 2. Transparent and Stained Finishes: Prepare samples on species and quality of wood to be used in the Work. Re-submit as requested until

acceptable sheen, color, and texture are achieved. Label and identify each sample as to location and application.

1.3 QUALITY ASSURANCE

- A. Labeling: Include following on label of each container:
 - 1. Manufacturer's name and product name.
 - 2. Generic type of paint.
 - 3. Manufacturer's stock number.
 - 4. Color.
 - 5. Instructions for reducing, where applicable.
- B. Special Requirements of Regulatory Agencies: Use materials for Work of this Section which comply with volatile organic compound limitations and other regulations of local Air Quality Management District and other local, state, and federal agencies having jurisdiction.
- C. Project Mock-Up: As directed by the Architect, apply on actual wall surfaces where designated, samples of each and any color selected for final review.
 - 1. On at least 100 square feet of surface as directed, provide full-coat finish samples until required sheen, color and texture are obtained.
 - 2. Duplicate painted finishes of prepared samples.
 - 3. Simulate finished lighting conditions for review of in-place work.

1.4 PRODUCT HANDLING

- A. Comply with requirements of Section 01 6000 – Product Requirements.
- B. Delivery: Deliver material in sealed containers with labels legible and intact.
- C. Storage of Materials:
 - 1. Store only acceptable Project materials on Project site.
 - 2. Store in suitable location.
 - 3. Restrict storage to paint materials and related equipment.
 - 4. Comply with health and fire regulations.

1.5 PROJECT CONDITIONS

- A. Environmental Requirements:

1. Comply with manufacturer's recommendations as to environmental conditions under which coatings and coating systems can be stored and applied.
 2. Do not apply finish in areas where dust is being generated.
- B. Protection: Cover or otherwise protect finished work of other trades and surfaces not being painted concurrently or not to be painted.

1.6 SCHEDULING

- A. Gypsum Board: Verify that a fully-cured skim coat has been applied to Gypsum Board specified for Level 5 finish and scheduled to receive semi-gloss or gloss paint finishes. Do not proceed until completed.

1.7 MAINTENANCE

- A. Extra Materials: At completion of Work, deliver to Owner extra stock of paint of one gallon of each color used of each coating material used. Tightly seal and clearly label containers.

PART 2 - PRODUCTS

2.1 MANUFACTURERS

- A. Primers and Single-color Paints: Provide paint systems as manufactured by the following manufacturers. Unless otherwise specified, single source all components of a paint system from a single manufacturer, including primer/sealer/undercoat and body and finish coats to assure compatibility.
1. Benjamin Moore and Co. (BM).
 2. ICI Dulux Paints (ICI).
 4. Sherwin-Williams Co. (S/W).

2.2 MATERIALS

- A. General: Provide materials selected for coating system for each type of surface which are the product of single manufacturer.
- B. Thinner: As recommended by each manufacturer for his respective product.
- C. Unsuitability of Specified Products: Claims concerning unsuitability of any materials specified will not be entertained, unless such claim is made in writing to the Architect before Work is started.

2.3 COLORS

- A. Color and Sheen: Colors are scheduled on Drawings (or as selected by Architect if not scheduled on Drawings) based on standard color chips provided by one or more of the listed manufacturers.
- B. Mixing: Deliver paints and stains ready mixed to Project site.

2.4 MILDEW RESISTANCE

- A. General: Add fungicidal agent to paint per manufacturer's recommendations. Add agent to paint at factory. Clearly indicate on labels that paint is mildew resistant.

PART 3 - EXECUTION

3.1 EXAMINATION

- A. Verification of Conditions: Examine surfaces scheduled to receive paint and finishes for conditions that might adversely affect execution, permanence, or quality of work and which cannot be put into acceptable condition through preparatory work. Proceed with preparation or coating application only when conditions are satisfactory.
- B. Review all questions regarding the scope of painting with Owner prior to proceeding with Work.

3.2 SURFACE PREPARATION

- A. General: Remove scale, dirt, dust, grit, rust, wax, grease, efflorescence, loose material, and other foreign matter detrimental to proper adhesion of paint.
- B. Gypsum Board:
 - 1. Narrow, Shallow Cracks and Small Holes: Fill with spackling compound.
 - 2. Deep, Wide Cracks and Deep Holes: Rake out, dampen with clear water, and fill with thin layers of gypsum board joint compound.
 - 3. Curing: Allow to dry.
 - 4. Sanding: Sand smooth after drying; do not raise nap of paper on gypsum board.
- C. Metals:
 - 1. Chipped or Abraded Areas in Shop Coatings: Touch-up using appropriate primer.
 - 2. Galvanized Surfaces: Apply a wash coat made by dissolving 8 ounces copper acetate or copper sulfate in one gallon of water; apply with brush.
 - 3. Stainless Steel: Scarify surfaces before applying prime coat.
- D. Wood:

1. General: If required, sandpaper surfaces smooth before applying primer. Thoroughly clean knots; apply thin coat of knot sealer over surfaces shown to receive opaque finish.
 2. Back Priming: Back prime surfaces installed against cementitious surfaces; give particular attention to sealing cross-grained surfaces.
 3. Puttying:
 - a. General: Fill nail holes, cracks, and other depressions flush with putty after prime coat application. Allow putty to dry; sandpaper smooth before applying body coat.
 - b. For Opaque Finish: Linseed oil type putty.
- E. Protection:
1. General: Properly protect floors and other adjacent work by drop cloths or other suitable coverings. In areas scheduled for painting, maintain wrappings and factory-applied protection provided by other trades.
 2. Hardware and Other Obstructions: Remove or protect factory finished items such as hardware, plates, lighting fixtures, grilles, and similar items placed prior to painting. Reposition or remove protection upon completion of each space. Equipment adjacent to surfaces requiring paint disconnected, moved, reset, and reconnected by respective trades.
 3. Fire Precautions: At end of each work day, place in metal containers or remove from premises, solvent soaked cloths, waste, and other materials which constitute a fire hazard.
- F. Moisture Content: Do not apply initial coating until moisture content of surface is within limitations recommended by paint manufacturer.

3.3 APPLICATION

- A. General: Apply paint per manufacturer's instructions and as specified. Thoroughly stir paint and keep at uniform consistency during application. Apply paint evenly, free from drops, ridges, waves, laps, and brush marks; finished surface uniform in sheen, color, and texture. Apply succeeding coats to unscarred and completely integral base coats; slightly vary color of undercoats to distinguish them from preceding coat. Allow sufficient time between coats to assure proper drying. Sandpaper smooth interior finishes between coats.
- B. Prime Coat: Do not thin primers in excess of manufacturer's printed directions. Apply by brush, unless otherwise specified, within 8 hours after cleaning.
- C. Body and Finish Coats: Do not thin; apply by brush, roller or spray.

- D. Drying Time: Comply with recommendations of product manufacturer for drying time between succeeding coats.
- E. Moldings and Ornaments: Leave clean and true to details with no undue amount of paint in corners and depressions.
- F. Edges of Paint: Where adjoining other materials or colors, make clean and sharp with no overlapping.
- G. Refinishing: Refinish entire wall where portion of finish is deemed not acceptable.
- H. Precaution: Do not paint over fusible links, UL labels, or sprinkler heads.
- I. Exposed Plumbing and Mechanical Items: Finish items without factory finish such as conduits, pipes, access panels, and items of similar nature to match adjacent wall and ceiling surfaces, unless otherwise directed.

3.4 CLEANING

- A. General: Touch up and restore finish where damaged. Remove spilled, splashed, or spattered paint from surfaces. Do not mar surface finish of item being cleaned.
- B. Storage Space: Leave clean and in condition required for equivalent spaces in Project.

3.5 PAINT SYSTEMS

- A. Schedule: Only major areas are scheduled. Treat miscellaneous and similar items and areas within room or space with similar system.
- B. Number of Coats: Where number of coats are specified, it is only as a minimum requirement. Apply additional coats, at no additional cost to Owner, if necessary to completely hide base material, produce uniform color, and provide satisfactory finish result.
- C. Thickness of Coats: For each paint system product, provide the manufacturer's recommended mil-thickness for each applied coat.
- D. Systems Specifications: These specifications are a guide and are meant to establish procedure and quality. Confer with Architect to determine exact finish desired.
- E. Acceptance of Final Colors: Do not apply final coats of paint for either exterior and interior systems until colors have been reviewed and accepted by the Architect.

3.6 INTERIOR PAINT SYSTEMS (Systems are based on products by S-W; other manufacturers listed in Part Two may be used)

- A. Interior Gypsum Board – Flat:

1. General: Provide as follows unless otherwise scheduled on Drawings or noted as follows in this Section.
 2. Flat Finish — Low Odor Zero VOC System
 3. Primer: ProMar 200 Zero VOC Interior Latex Primer, B28W2600, 0 g/L VOC
 4. 1st coat: ProMar 200 Zero VOC Flat, B30-2600 series, 0 g/L VOC
 5. 2nd coat: ProMar 200 Zero VOC Flat, B30-2600 series, 0 g/L VOC
- B. Interior Gypsum Board – Eggshell/Satin:
1. General: Provide as follows unless otherwise scheduled on Drawings or noted as follows in this Section.
 2. Primer: ProMar 200 Zero VOC Interior Latex Primer, B28W2600 0 g/L VOC
 3. 1st coat: ProMar 200 Zero VOC Eg-Shel B26-2600 series, 0 g/L VOC
 4. 2nd coat: ProMar 200 Zero VOC Eg-Shel B26-2600 series, 0 g/L VOC
- C. Interior Gypsum Board – Semi-gloss:
1. General: Provide at stairs, service areas and where scheduled.
 2. Primer: ProMar 200 Zero VOC Interior Latex Primer, B28W2600, 0 g/L VOC
 3. 1st coat: ProMar 200 Zero VOC Semi-Gloss B31-2600 series, 0 g/L VOC
 4. 2nd coat: ProMar 200 Zero VOC Semi-Gloss B31-2600 series, 0 g/L VOC
- D. Interior Gypsum Board – Epoxy Coatings:
1. General: Provide at Restroom and other gypsum surfaces as scheduled on Drawings and required by the the governing Health Codes:
 2. Eg-Shel Finish
 - a. Primer: ProMar 200 Zero VOC Primer, B28W2600, 0 g/L VOC
 - b. 1st coat: Pro Industrial Pre-Catalyzed Water-Based Epoxy Eg-Shel, K45 series, <150 g/L VOC
 - c. 2nd coat: Pro Industrial Pre-Catalyzed Water-Based Epoxy Eg-Shel, K45 series, <150 g/L VOC
 3. Semi-Gloss Finish (typical, unless noted otherwise)
 - a. Primer: ProMar 200 Zero VOC Primer, B28W2600, 0 g/L VOC
 - b. 1st coat: Pro Industrial Pre-Catalyzed Water-Based Epoxy Semi-Gloss, K46 series, <150 g/L VOC
 - c. 2nd coat: Pro Industrial Pre-Catalyzed Water-Based Epoxy Semi-Gloss, K46 series, <150 g/L VOC
 4. Gloss Finish
 - a. Primer: ProMar 200 Zero VOC Primer, B28W2600, 0 g/L VOC
 - b. 1st coat: Pro Industrial Zero VOC Water-Based Epoxy Gloss, B73-300 series, 0 g/L VOC
 - c. 2nd coat: Pro Industrial Zero VOC Water-Based Epoxy Gloss, B73-300 series, 0 g/L VOC
- E. Interior Ferrous Metal:

1. General: Shop and field-applied paint finishes for the Work of Section 050500 – Metal Fabrications, is included in the Scope of Work for those Sections.
2. For other exposed-to-view ferrous metal items, including items specified in DIVISION 23 – Mechanical; and DIVISION 26 – Electrical, provide the finishes as follow:
3. Bare Metal Items; High Performance Coating System: Mechanical and Electrical Piping, Conduits, Ductwork, Supports, Hangers, Machinery and Similar Items:
 - a. Eg-Shel or Gloss Finish (Verify with Architect for each room / area prior to painting)
 - b. Primer: Pro Industrial Pro-Cryl Universal Primer, B66-310 series, <100 g/L VOC
 - c. 1st coat: Pro Industrial Zero VOC Water-Based Epoxy Eg-Shel, B73-360 series or Gloss, B73-300 series, 0 g/L VOC
 - d. 2nd coat: Pro Industrial Zero VOC Water-Based Epoxy Eg-Shel, B73-360 series or Gloss, B73-300 series, 0 g/L VOC
4. Shop Primed or painted (by others) Items; Semi-Gloss finish:
 - a. Primer: Pro Industrial Pro-Cryl Universal Primer, B66-310 series, <100 g/L VOC
 - b. 1st coat: Pro Industrial Zero VOC Acrylic Semi-Gloss, B66-650 series, 0 g/L VOC
 - c. 2nd coat: Pro Industrial Zero VOC Acrylic Semi-Gloss, B66-650 series, 0 g/L VOC
5. Shop Galvanized Items:
 - a. Galvanizing repair provided in Section 050500 – Metal Fabrications.
 - b. Galvanized Metal Decking & Ferrous Decking — Including Bar Joists
 - i. Flat, Eg-Shel, or Semi-Gloss Finish
 - ii. Primer: Pro Industrial Pro-Cryl Universal Primer, B66-310 series, <100 g/L VOC
 - iii. 1st coat: Low VOC Waterborne Acrylic Dryfall, Flat B42W81, Eg-Shel B42W82, Semi-Gloss, B42W83, All sheens <50 g/L VOC
 - iv. 2nd coat: Low VOC Waterborne Acrylic Dryfall, Flat B42W81, Eg-Shel B42W82, Semi-Gloss, B42W83, All sheens <50 g/L VOC
 - c. Galvanized Metal Decking & Ferrous Decking — Including Bar Joists – High Performance System
 - i. Primer: Pro Industrial Pro-Cryl Universal Primer, B66-310 series, <100 g/L VOC
 - ii. 1st coat: Pro Industrial Multi-Surface Acrylic Eg-Shel, B66-560 series, <150 g/L VOC
 - iii. 2nd coat: Pro Industrial Multi-Surface Acrylic Eg-Shel, B66-560 series, <150 g/L VOC

- F. Interior Aluminum and Copper:
1. Refer to Section 076200 – Flashing and Sheet Metal for shop and field-applied paint finishes specified in those Sections.
 2. Mechanical and Electrical Items:
 - a. Pretreatment: Metal Pretreatment.
 - b. 1st Coat: Aluminum Primer. Provide additional general purpose sealer coat when recommended by paint manufacturer.
 - c. 2nd Coat: Acrylic Paint, Semi-Gloss.
 - d. 3rd Coat: Acrylic Paint, Semi-Gloss.
- G. Interior Wood:
1. General: Transparent Finishes are specified and provided in Section 064123 Interior Architectural Woodwork
 2. Semi-Gloss Finish — Low Odor Zero VOC System
 3. Primer: ProMar 200 Zero VOC Primer, B28W2600, 0 g/L VOC
 4. 1st coat: Pro Industrial Zero VOC Acrylic Semi-Gloss, B66-650 series, 0 g/L VOC
 5. 2nd coat: Pro Industrial Zero VOC Acrylic Semi-Gloss, B66-650 series, 0 g/L VOC
- H. Interior Mechanical Insulation; Finish Varies:
1. Provide finish materials recommended in writing by the mechanical insulation manufacturer for their products in exterior locations. Adapt the following as required.
 - a. 1st Coat: General Purpose PVA Sealer, or as recommended by the insulation manufacturer.
 - b. 2nd Coat: Match adjacent finish system.
- I. Miscellaneous Interior Painting Systems:
1. Ductwork at Grilles and Diffusers:
 - a. Apply interior surfaces of ductwork partially visible through grilles and diffusers.
 - b. 1st Coat: Galvanized Metal Primer.
 - c. 2nd Coat: Acrylic Paint, Matte Black.
 - d. 3rd Coat: Acrylic Paint, Matte Black.
 2. Exposed Insulated Pipes and Ductwork:

- a. 1st Coat: 1 coat General Purpose PVA sealer. Omit sealer where glass fabric jackets are used.
 - b. 2nd Coat: Acrylic Paint, match adjacent finish.
 - c. 3rd Coat: Acrylic Paint, match adjacent finish.
3. Exposed Non-Insulated Pipes and Ductwork: Including conduit.
- a. Cast-Iron Pipe:
 - 1) Pre-treatment: Conform with the requirements of Section 050500 – Metal Fabrications.
 - 2) 1st Coat: Ferrous Metal Primer.
 - 3) 2nd Coat: Acrylic Paint, match adjacent finish.
 - 4) 3rd Coat: Acrylic Paint, match adjacent finish.
 - b. Other Pipes, Conduit, and Ductwork:
 - 1) Pre-treatment: Conform with the requirements of Section 050500 – Metal Fabrications.
 - 2) 1st Coat: As specified for ferrous and non-ferrous metals as applicable.
 - 3) 2nd Coat: Acrylic Paint, match adjacent finish.
 - 4) 3rd Coat: Acrylic Paint, match adjacent finish.
- J. Miscellaneous Interior Painting Systems:
1. Factory Finished Equipment: Satisfactorily refinish surfaces damaged before, during, or after installation as directed; use 128 semi-gloss enamel.
 2. Plywood Equipment Backing:
 - a. General: Telephone, Data and Electric Closets.
 - b. 1st Coat: Latex Enamel Undercoater.
 - c. 2nd Coat: Acrylic Paint; match adjacent finish.
 - d. 3rd Coat: Acrylic Paint; match adjacent finish.
- K. Pipe Identification:
1. General: Per ANSI A13.1; buried pipe, electrical conduit, and pipe in concealed spaces such as furred spaces and shafts not included.

2. Color Scheme: ANSI Z53.1 in combination with legend and flow markers; continuous total length coverage. Safety colors as specified under applicable Mechanical Section.
3. Legend: Stencil letters of colors, type, and sizes per ANSI A13.1. Tags for identification of pipes less than 3/4-inch overall outside diameter, including valves and fittings; provided under applicable mechanical Section.
4. Flow Markers: Provide each type with appropriate size arrows to indicate flow direction in pipe; same color as legend.
5. Visibility: Locate legend and flowmarkers for easy visibility from operating floor; space not over 20 feet with at least one per room.

3.8 CLEANING:

- A. Comply with provisions of Section 017900 – Cleaning.
- B. Remove paint spots, oil, and stains from adjacent surfaces upon completion of Work; leave Work clean.

END OF SECTION

SECTION 10 11 00 - VISUAL DISPLAY SURFACES

PART 1 - GENERAL

1.1 RELATED DOCUMENTS

- A. Drawings and general provisions of the Contract, including General and Supplementary Conditions and Division 1 Specification Sections, apply to this Section.

1.2 SUMMARY

- A. This Section includes the following:
 - 1. Porcelain enamel markerboards.
 - 2. Vinyl-fabric-faced cork tackboards.

1.3 SUBMITTALS

- A. Product Data: For each type of visual display board indicated. Include motor capacities and individual panel weights for sliding chalkboard and markerboard units.
- B. Samples for Initial Selection: Manufacturer's color charts showing the full range of colors and textures available for the following:
 - 1. Markerboards: Actual sections of porcelain enamel finish for each type of chalkboard and markerboard required.
 - 2. Vinyl-Fabric-Faced Cork Tackboards: Fabric swatches for each type of vinyl-fabric-faced cork tackboard indicated.

1.4 QUALITY ASSURANCE

- A. Installer Qualifications: Engage an experienced installer who is an authorized representative of chalkboard manufacturer for both installation and maintenance of the type of sliding chalkboard units required for this Project.
- B. Source Limitations: Obtain visual display boards through one source from a single manufacturer.
- C. Product Options: Drawings indicate size, profiles, and dimensional requirements of visual display boards and are based on the products indicated. Other manufacturers' products with equal performance characteristics may be considered. Refer to Division 1 Section "Substitutions."
- D. Fire-Test-Response Characteristics: Provide vinyl-fabric-faced tackboards with the following surface-burning characteristics as determined by testing assembled materials composed of facings and backings identical to those required in this Section per ASTM E 84 by a testing and inspecting agency acceptable to authorities having jurisdiction. Identify vinyl-fabric-faced tackboards with appropriate markings of applicable testing and inspecting agency.
 - 1. Flame Spread: 25 or less.
 - 2. Smoke Developed: 10 or less.

PART 2 - PRODUCTS

2.1 MANUFACTURERS

- A. Manufacturer: Subject to compliance with requirements, provide products by one of the following:
1. Porcelain Enamel Markerboards:
 - a. Best-Rite Chalkboard Co.
 - b. Carolina Chalkboard Co.
 - c. Claridge Products and Equipment, Inc.
 - d. Ghent Manufacturing, Inc.
 - e. Greensteel, Inc.
 - f. Lemco, Inc.
 2. Tackboards:
 - a. Best-Rite Chalkboard Co.
 - b. Claridge Products and Equipment, Inc.
 - c. Ghent Manufacturing, Inc.
 - d. Greensteel, Inc.
 - e. Lemco, Inc.
 - f. Nelson Adams Company.
 - g. Newline Products, Inc.

2.2 MATERIALS

- A. Porcelain Enamel Markerboards: Balanced, high-pressure-laminated, porcelain enamel chalkboards of 3-ply construction consisting of face sheet, core material, and backing.
1. Face Sheet: 0.024-inch enameling grade steel especially processed for temperatures used in coating porcelain on steel. Coat exposed face and edges with a 3-coat process consisting of primer, ground coat, and color cover coat. Coat concealed face with a 2-coat process consisting of primer and ground coat. Fuse cover and ground coats to steel at manufacturer's standard firing temperatures, but not less than 1200 deg F.
 - a. Cover Coat: Provide manufacturer's standard finish cover coat, with color selected from manufacturer's standards.
 2. Core: 3/8-inch-thick, particleboard core material complying with requirements of ANSI A208.1, Grade 1-M-1.
 3. Backing Sheet: 0.005-inch-thick, aluminum-foil sheet backing.
- B. Vinyl-Fabric-Faced Tackboards: Mildew-resistant, washable vinyl fabric complying with FS CCC-W-408, Type II, weighing not less than 13 oz./sq. yd., laminated to 1/4-inch-thick cork sheet. Provide fabric with a flame-spread rating of 25 or less when tested according to ASTM E 84. Provide color and texture as scheduled or as selected from manufacturer's standards.
1. Backing: Factory laminate cork face sheet under pressure to 3/8-inch-thick fiberboard backing.

2.3 ACCESSORIES

- A. Metal Trim and Accessories: Fabricate frames and trim of not less than 0.062-inch-thick, extruded-aluminum alloy, size and shape as indicated, to suit type of installation. Provide straight, single-length units. Keep joints to a minimum. Miter corners to a neat, hairline closure.

2.4 FABRICATION

- A. Porcelain Enamel Chalkboards: Laminate facing sheet and backing sheet to core material under pressure with manufacturer's recommended flexible, waterproof adhesive.
- B. Assembly: Provide factory-assembled chalkboard and tackboard units, unless field-assembled units are required.
 - 1. Make joints only where total length exceeds maximum manufactured length. Fabricate with minimum number of joints, balanced around center of board, as acceptable to Architect.
 - 2. Provide manufacturer's standard vertical joint system between abutting sections of chalkboards.

2.5 FINISHES

- A. General: Comply with NAAMM's "Metal Finishes Manual for Architectural and Metal Products" for recommendations relative to applying and designating finishes.
- B. Finish designations prefixed by AA conform to the system established by the Aluminum Association for designating aluminum finishes.
- C. Class II, Clear Anodic Finish: AA-M12C22A31 (Mechanical Finish: nonspecular as fabricated; Chemical Finish: etched, medium matte; Anodic Coating: Architectural Class II, clear coating 0.010 mm or thicker) complying with AAMA 607.1.

PART 3 - EXECUTION

3.1 EXAMINATION

- A. Examine wall surfaces, with Installer present, for compliance with requirements and other conditions affecting installation of visual display boards.
 - 1. Surfaces to receive chalkboards or markerboards shall be free of dirt, scaling paint, and projections or depressions that would affect smooth, finished surfaces of chalkboards or markerboards.
 - 2. Do not proceed with installation until unsatisfactory conditions have been corrected.

3.2 INSTALLATION

- A. Deliver factory-built visual display boards completely assembled in one piece without joints, where possible. If dimensions exceed panel size, provide 2 or more pieces of equal length as acceptable to Architect. When overall dimensions require delivery in separate units, prefit components at the factory, disassemble for delivery, and make final joints at the site. Use splines at joints to maintain surface alignment.

- B. Install units in locations and at mounting heights indicated and according to manufacturer's written instructions. Keep perimeter lines straight, plumb, and level. Provide grounds, clips, backing materials, adhesives, brackets, anchors, trim, and accessories necessary for complete installation.
- C. Install units tight to wall surfaces at top, sides and bottom.

3.3 ADJUSTING AND CLEANING

- A. Verify that accessories required for each unit have been properly installed and that operating units function properly.
- B. Clean units according to manufacturer's written instructions.

END OF SECTION

SECTION 10 26 00 – WALL AND DOOR PROTECTION

PART 1 - GENERAL

1.1 SUMMARY

A. Work Included: Provide and install wall protection, wall corner guards and other finish protection products, complete, as shown on Drawings and as specified, including:

1. Surface-Mounted Corner Guards and Partition End Guards.
2. Protective Wall Covering Wainscot
3. Crash Rails
4. Stainless Steel Door Frame Covers

B. Work Specified Elsewhere:

1. Section 081113 – Hollow Metal Doors and Frames.
2. Section 084113 – Aluminum Entrances and Storefronts.
3. Section 081416 – Flush Wood Doors.
4. Section 079200 – Joint Sealants.
5. Section 087100 – Door Hardware
6. Section 092216 – Non-Structural Metal Framing.

1.2 SUBMITTALS

A. Comply with provisions of Section 013300 – Submittal Procedures.

B. Product Data: Manufacturer's catalog cuts, standard color charts, and data sheets; including installation details and instructions, for each item specified.

C. Samples:

1. Crash Rails: 12-inch-long piece of each type specified, including color.
2. Corridor Handrail: 12-inch-long piece of each specified type, including mounting bracket and specified finish.
3. Partition End and Corner Guards: 12-inch-long piece of each type specified, including color.
4. Wall protection and Door Protection: 12-inch-square piece of each specified type, including corner and specified color.

1.3 PRODUCT HANDLING

- A. Delivery and Storage: Deliver and store items and related fasteners in manufacturer's original packaging, identified with manufacturer's name and type of product, and size. Store materials indoors, protected from moisture and other sources of damage.

PART 2 - PRODUCTS

2.1 MANUFACTURER

- A. General: Provide vinyl/acrovyn wall and corner protection single-sourced from one manufacturer to assure color matching.
- B. Manufacturer: Inpro Corporation, Construction Specialties, Inc., Pawling Corporation OR Korogard
 - a. Basis-of-Design: Construction Specialties Acrovyn 4000
- C. Fire Hazard Classification: Flame spread of 25 or less when tested per ASTM E84.

2.3 CORNER GUARDS

- A. Type: C/S Acrovyn 4000 Corner Guards – SSM-20AN with continuous aluminum retainer.
 - 1. Size: 2" X 2" X 4'-0".
 - 2. Mounting Style: Surface-mounted.
 - 3. Color: As scheduled on Drawings.
 - 4. Mounting Height: 4 feet high from top of base unless noted otherwise.
 - 5. Locations: Typical at all corners and as shown on Drawings.

2.4 PROTECTIVE WALL COVERING WAINSCOT

- A. Type: Sheet plastic wall protection by C/S acrovyn. Typical where shown on Drawings.
 - 1. Size: 0.06" thick Acrovyn 4000 panels by sizes shown on Drawings.
 - 2. Mounting Style: Surface-mounted.
 - 3. Color: As scheduled on Drawings.
 - 4. Mounting Height: From finished floor to 4 feet above base unless noted otherwise. Align top of wall protection with top of corner guards where occurs.
 - 6. Locations: As shown on Drawings.

- B. Type: Stainless steel wall panels. Basis of design: Inpro.
1. Panel Size: 4' x 10'
 2. Panel Thickness: 18 gauge, Stainless Steel Type 304
 2. Mounting Style: Surface-mounted.
 3. Mounting Height: From finished floor to 4 feet above base unless noted otherwise. Align top of wall protection with top of corner guards where occurs.
 4. Inside and Outside Corners: 2" x 2" x 16 gauge
 5. Locations: All walls in Sterile Processing and Decontamination Rooms.

2.5 CRASH RAILS

- A. Manufacturer: Acrovyn by Construction Specialties, Inc. (C/S); IPC Door and Wall Protection by InPro Corporation (IPC). C/S Acrovyn specified as basis-of-design.
- B. Type: Construction Specialties Acrovyn SCR-64 MN, surface-mounted crash rail with continuous aluminum retainer. Typical at corridors, as shown on Drawings.
1. Size: 1-1/4-inch-wide by 8 inches X continuous.
 2. Mounting Style: BCR-64, maximum projection from wall 1-1/2-inch.
 3. Color: As scheduled on Drawings.
 4. Mounting Height: As shown on Drawings.
 7. Locations: Typical at all 8 feet corridors.

2.6 ~~HANDRAILS~~

- ~~A. Manufacturer: Acrovyn by Construction Specialties, Inc. (C/S); IPC Door and Wall Protection by InPro Corporation (IPC). C/S Acrovyn specified as basis-of-design.~~
- ~~B. Type: Construction Specialties Acrovyn HRWS-6C, surface-mounted crash rail. Typical at corridors, as shown on Drawings.~~
- ~~1. Overall Projection from Wall: 3 inches.~~
 - ~~2. Overall Height: 4-3/32 inches.~~
 - ~~3. Wood Finish: Natural Maple.~~
 - ~~4. Mounting Height: As shown on Drawings.~~

-
- 5. ~~Locations: Typical at all patient room side of the wall and as shown on Drawings.~~
 - 8. ~~Include manufacturer's stainless steel (Model 245069000) Splice at mid-point of all runs that exceed maximum dowel length.~~

2.7 PARTITION END PROTECTION

- A. Manufacturer: Acrovyn by Construction Specialties, Inc. (C/S); IPC Door and Wall Protection by InPro Corporation (IPC).C/S Acrovyn specified as basis-of-design.
- B. Type: Composite assembly consisting of two Acrovyn SSM-20AN corner guards and partition-end infill panel of adhesive-applied .040-inch-thick Acrovyn sheet.
 - 1. Size: Verify partition width; 2-inch return at each wall face.
 - 2. Mounting Style: Surface-mounted.
 - 3. Color: As scheduled on Drawings.
 - 4. Mounting Height: From finish floor to 4 feet above base.
 - 5. Provide manufacturer's coordinated top and bottom caps.
 - 5. Locations: At all wall end partitions, typical.

2.8 STAINLESS STEEL DOOR FRAME COVERS

- A. Manufacturer: Manufacturer: ProTek Systems, Inc. OR approved equal. Basis of design is ProTek Systems
 - 1. 1250 Wallace Dr. Unit B, Delray Beach, FL 33444
Toll-free: 800.598.2153 Fax: 561.395.4771
 - 2. E-mail: projects@protekm.com Web Site: www.proteksystem.com.
- B. Type: DFC-16 Stainless Steel Door Frame Cover by ProTek Systems, Inc.
 - 1. Material: Type 304 #4 satin stainless steel sheet. Consult factory for recommended gauge.
 - 2. Fabricated to custom measurements.
 - 3. Finish: #4 satin
- C. Accessories:
Mounting Method: Adhesive OR mechanical fasteners
 - 1. ADH-50 Construction Adhesive
 - 2. Mechanical fasteners: Specify drilling requirements when ordering. Fasteners by others.

2.9 MISCELLANEOUS MATERIALS

- A. Fasteners: Manufacturer's standard, removable, corrosion-resistant fasteners of size and length suitable for the conditions of installation.
- B. Adhesive: As recommended by manufacturer for setting material.
- C. Backing Plates: As specified in Section 092216 – Non-Structural Metal Framing and as shown on Drawings.
- D. Products shall be furnished as a complete packaged system, including appropriate Adhesive, Primer, Caulking and Trims per manufactures recommendations.

PART 3 - EXECUTION

3.1 EXAMINATION

- A. Verification of Conditions: After application of wall base and finish painting of walls is complete, examine areas and conditions under which items are to be installed. If unsatisfactory conditions exist, do not proceed with the Work until such conditions have been corrected.

3.2 PREPARATION

- A. Cleaning: Prior to application, clean side of units that will be in contact with wall surface.

3.3 INSTALLATION

- A.** Install the work of this section in strict accordance with the manufacturer's recommendations, using only approved mounting hardware and locating all components firmly into position, level and plumb.
- B.** Temperature at the time of installation must be between 65°-75°F (18°-24°C) and be maintained for at least 48 hours after the installation.
- C.** Adjust installed end caps as necessary to ensure tight seams.

3.4 ADJUSTING AND CLEANING

- A. Cleaning: Prior to time of final acceptance, strip units of protective coverings, and clean in accordance with manufacturer's instructions.
- B. Defective Materials: Remove and replace any defective, misaligned, or damaged units, at no additional cost to Owner.

END OF SECTION

SECTION 10 28 00- TOILET AND BATH ACCESSORIES

PART 1 - GENERAL

1.1 SUMMARY

- A. Work included: Provide and install toilet accessories as shown on Drawings and as specified, including:
 - 1. Single-accommodation toilet room accessories.
- B. Work Specified Elsewhere:
 - 1. Section 088000 –Glazing.
 - 2. Section 092216 – Non-Structural Metal Framing.
 - 3. Division 23 – Mechanical (Pipe Protection under Lavatories).

1.2 SUBMITTALS

- A. Comply with provisions of Section 013300 – Submittal Procedures
- B. Manufacturer's literature describing products.
- C. Shop Drawings: Show methods of backing, installation, and fastening.

1.3 QUALITY ASSURANCE

- A. Installed grab bars shall withstand 300 pounds downward pull.
- B. Design, quality, capacity, function, and finish shall conform with manufacturer's descriptions corresponding to catalog numbers cited unless otherwise noted.
- C. Provide the same keying for all locks of all accessory units specified.

1.4 DELIVERY, STORAGE AND HANDLING

- A. Comply with requirements of Section 016000 – Product Requirements.
- B. Deliver materials and products in original containers with seals unbroken and labels intact until time of use. Label shall identify accessory, catalog number and finish.
- C. Store delivered products in clean, safe, dry area.

1.5 PROJECT CONDITIONS

- A. Comply with requirements of Section 013100 – Project Management and Coordination.
- B. Coordinate as required with work of other sections to ensure proper backing.
- C. Sequencing, Scheduling: Do not install accessories until after completion of finish painting.

PART 2 - PRODUCTS

2.1 ACCEPTABLE MANUFACTURERS

- A. General: Bobrick Washroom Equipment, Inc., no substitutions permitted unless otherwise specified. Accessory items specified by Bobrick catalog numbers.

2.2 PRODUCTS:

A. Grab Bars:

Provide heavy duty 18-gauge, type 304 stainless steel grab bars complying with the following:

1. Products: Bobrick; B-5806, 18", 24", 36" & 42" grab bars as indicated on drawings.
2. Mounting: Concealed with manufacturer's standard flanges and anchors.
3. Gripping Surfaces: Smooth, satin finish.
4. Outside Diameter: 1-1/4 inches for heavy-duty applications.

B. Mirror Unit:

Provide mirror unit complying with the following:

1. Products: Bobrick; B-165, 24" x 36" without shelf.
2. Stainless-Steel, Channel-Framed Mirror: Fabricate frame from stainless-steel channels in manufacturer's standard satin or bright finish with square corners mitered to hairline joints and mechanically interlocked.

C. Robe Hooks:

1. Model B-6717; single robe hook; surface-mounted; Type 304, stainless steel with satin finish.

~~D. Toilet Paper Dispenser:~~

- ~~1. Model B-4288 Contura Series multi-roll dispenser; satin stainless steel finish.~~

C. Toilet Seat Cover Dispenser:

1. Model B-221 Surface-Mounted Toilet Seat Cover Dispenser; dispenses 250 single or half-fold seat covers; Type 304 stainless steel satin finish; fill from bottom through concealed opening.
- D. Sanitary Napkin Disposal:
1. Model B-270; Contura series, surface mounted sanitary napkin dispenser with full-length piano hinge and hinged bottom with tumbler lock; type 304 stainless steel with satin finish.
- E. Specimen Pass-Thru Cabinet:
1. Model B-505; Recessed specimen pass-thru cabinet. Type 304 stainless steel, satin finish. Self-closing doors
- F. Mop and Broom Holder:
1. Model B-223x36; anti-slip mop holders with spring-loaded rubber cam on steel retainers; surface-mounted; Type 304 satin finish stainless steel; 36 inches long.
- G. Stainless Steel Shelf:
1. Model B-295 x16; 16" long X 5" wide, 18-gauge, type 304 stainless steel, satin finish, 3/4" return edge; front edge hemmed for safety. Brackets 16-gauge
- H. Folding Shower Seat:
1. Model B-5181, Reversible Folding Shower Seat. Water-resistant, thick solid phenolic. Reversible for left- or right-hand field installation. Frame and mounting brackets: type 304 stainless steel with self-locking mechanism.
- I. Recessed Heavy-Duty Soap Dish:
1. Model B-4380. Type 304 stainless steel, matte polished finish.
- J. Baby Changing Station:
1. Koala Model KB200-01SS GREY Surface-Mounted Baby Quick Change; Polypropylene cabinet and bed with stainless steel veneer, 35 3/16 inches wide by 22 1/4 inches high by 4 inches deep.

PART 3 - EXECUTION

3.1 EXAMINATION

- A. Examine area to receive toilet or bath accessories and certify that:
1. Backing not included in work of this section is correct.
 2. Surfaces are dry, clean, free from foreign matter, and otherwise proper for installation.

3. Toilet compartments or dressing rooms, to receive accessories have been properly installed and correctly prepared.
- B. Do not begin work until unsatisfactory conditions have been corrected.

3.2 INSTALLATION

- A. Install accessories in accordance with approved manufacturer's recommendations.
- B. Attach accessories securely to substantial backing, with concealed fastenings unless otherwise noted; insure true alignment.
- C. Adjust as required for correct operation.

3.3 CLEANING AND ADJUSTMENTS

- A. Comply with requirements of Section 017900 – Cleaning.
- B. Adjust units as necessary to assure smooth, quiet operation without catching, binding or malfunctioning.

END OF SECTION

SECTION 10 44 13 – FIRE PROTECTION CABINETS AND FIRE EXTINGUISHERS

PART 1 - GENERAL

1.1 SUMMARY

- A. Work Included: Provide and install fire extinguishers and cabinets and accessories as shown on Drawings and as specified, including:
 - 1. Fire extinguishers.
 - 2. Fire extinguisher cabinets and accessories.

- B. Work Specified Elsewhere:
 - 1. Section 092216 – Non-Structural Metal Framing.
 - 2. Section 092900 – Gypsum Board.
 - 3. Section 099123 – Interior Painting.

1.2 SUBMITTALS

- A. Comply with provisions of Section 013300 – Submittal Procedures.
- B. Submit manufacturer's literature describing products.
- C. Shop Drawings: Submit showing locations, sizes, methods of attachment, and rough-in dimensions.
- D. Certification: Installer shall submit written certification that the fire extinguishers installed comply with the contract documents and are fully and correctly charged.

1.3 QUALITY ASSURANCE

- A. Single-Source Responsibility: Obtain extinguishers and cabinets from one source from a single manufacturer.
- B. Provide only fire extinguishers which comply with NFPA 10.
- C. UL Listed Products: Fire extinguishers shall be UL Listed with UL Listing mark for type, rating, and classification of extinguisher.
- D. Conform to NFPA 10, International Building Code (IBC) with 2003 Utah Amendments, and local Fire Marshall requirements, including:
 - 1. Location: Provide portable fire extinguishers within 75 feet maximum travel distance to any occupied interior portion of the building.

2. Provide additional high hazard portable fire extinguishers in hazardous locations as local governing codes.

1.4 DELIVERY, STORAGE, AND HANDLING

- A. Comply with provisions of Section 016000 – Product Requirements.
- B. Deliver and store packaged products in original containers with seals unbroken and labels intact until time of use.
- C. Provide proper facilities for handling and storage of products to prevent damage. Where necessary, stack products off ground on level platform, fully protected from weather.

1.5 PROJECT CONDITIONS

- A. Sequencing: Schedule installation of items to occur after application of exposed finishes wherever installation will not damage exposed finish surfaces and completion of finishes will not impede installation.
- B. Do not deliver or install extinguishers until just before substantial completion.
- C. Do not use permanent fire extinguishers for construction period fire protection.

PART 2 – PRODUCTS

2.1 FIRE EXTINGUISHERS

- A. Manufacturer: Provide products manufactured by Potter Roemer; Div. of Smith Industries, Inc; Amerex Corporation; JL Industries, Inc; Larsen's Manufacturing Company; or equal.
 1. Basis-of-Design: Products manufactured by Activar Inc, JL Industries are the Basis-of-Design for sizes as shown on Drawings.
- B. Fire Extinguisher Types:
 1. Typical:
 - a. UL Rating: 4A-80BC; 10-pound capacity, or greater.
 - b. Type: ABC multi-purpose dry chemical; stored pressure type.
 - c. Model: JL Industries, Cosmic 10E
 - d. Cabinet mounted (typical).
 - e. Provide bracket mount where cabinets are not shown on Drawings.

2.2 CABINETS AND CABINET ACCESSORIES

A. Cabinet Type (All Locations except for Operating Rooms):

Fully Recessed style with duo vertical panel with pull handle.

1. Construction of cold rolled steel formed, mitered, welded and ground smooth; 20 gauge tubular door and 18 gauge frame; rolled radius edge treatment.
2. Cabinet door and trim shall be finished with white power coat finish.
3. Interior shall be finished in white baked enamel.
4. Provide JL Industries, 1035 V/W Vertical Duo with 3/8" flat trim fully recessed.

C. Hinges: Provide hinges for each door; concealed or continuous type; allow full 180 degree opening of door.

1. Exposed hinges: Finish to match door.

D. Cabinet Type at Operating Rooms

Fully Recessed style with duo vertical panel with pull handle.

1. #4 Stainless Steel cabinet with clear tempered glazing
2. Door Style: Vertical Duo with 3/8" flat trim fully recessed.

PART 3 - EXECUTION

3.1 EXAMINATION

A. Examine construction to support, adjoin, or otherwise contact and verify that:

1. Dimensions are correct.
2. Load-bearing studs or backing are available where required by weight of items.
3. Setting conditions are dry, clean, and otherwise proper for installation.

B. Do not install items until unsatisfactory conditions have been corrected.

3.2 PREPARATION

A. Coordinate details with other work supporting, adjoining, or otherwise contacting items as required to insure proper installation.

3.3 INSTALLATION

- A. Perform installation in accordance with the manufacturer's printed instructions except where more stringent requirements are shown or specified.
 - 1. Comply with Contract Documents where project conditions require extra precautions or provisions to ensure satisfactory performance of the work.
- B. Install extinguishers and cabinets at locations indicated in accordance with approved shop drawings.
 - 1. Typical Fastenings: Use machine screws or bolts to metal backing. Toggle bolts will not be permitted.
 - 2. Drill and tap mounting surfaces for mounting hardware as required.
- C. Install so that top of cabinet is 54 inches above finish floor.

END OF SECTION

SECTION 105113 – METAL LOCKERS

PART 1 - GENERAL

1.1 SUMMARY

- A. Work Included: Provide and install lockers and accessories as shown on Drawings and as specified, including:
 - 1. "Standard Grade" Metal Lockers in manufacturer's standard configurations.
- B. Work Specified Elsewhere:
 - 1. Section 079200 – Sealants.
 - 2. Section 092216 – Non-Structural Metal Framing.

1.2 SUBMITTALS

- A. Comply with provisions of Section 013300 – Submittal Procedures.
- B. Submit manufacturer's literature describing products.
- C. Shop Drawings: Provide layout, dimensions, details of construction, fitting of closures, locker numbering system, and attachment to adjacent surfaces.
- D. Samples:
 - 1. Submit manufacturer's metal finish samples in colors as shown on Finish Schedule.

1.3 DELIVERY, STORAGE, AND HANDLING

- A. Comply with requirements of Section 016000 – Product Requirements.
- B. Identify type, size, and location of lockers before site delivery in manner not to damage finish.
- C. Deliver products only after proper storage facilities are available.
- D. Handle carefully to prevent damage and store on clean concrete surface or raised platform in safe, dry area. Do not dump onto ground.

PART 2 - PRODUCTS

2.1 MANUFACTURERS

A. "Standard" Metal Lockers:

1. Art Metal Products; Div. of Fort Knox Storage Co.
2. Interior/Medart.
3. Lyon Metal Products, Inc.
4. Penco Products, Inc.; Subsidiary of Vesper Corporation.
5. Republic Storage Systems Co., Inc.

2.2 LOCKER TYPES

A. "Standard Grade" Metal Lockers:

1. Configuration: Provide Layouts as shown on Drawings,
2. Sizes: Provide sizes shown on Drawings. 15"W X 18"D X 3'-0"H- 2 Tier
3. Ventilation: Provide manufacturer's standard ventilation layout for each locker configuration.
4. Locks: Built-in master-keyed flat key lock.
5. Base: Closed.
6. Top: Provide manufacturer's standard flat locker tops and accessories.

2.3 METAL LOCKER MATERIALS AND COMPONENTS

A. Sheet Steel:

1. For Doors, Door Frames, Shelves, Bases, Fillers, Closures, and Trim: Cold-rolled and stretcher-leveled sheet steel, minimum 16 gauge.
2. For Bodies and Dust Covers: Mild cold-rolled sheet steel, minimum 24 gauge.

B. Lock Bars: Channel-formed steel with latching fingers to operate independently of bar such that lock bar drops into locked position immediately after door is opened and handle released.

1. Provide typically except at box lockers.
2. Provide at least 2 locking points for lockers 48 inches high or less.
3. Provide at least 3 locking points for lockers greater than 48 inches high.

- C. Handles: Die-Cast zinc alloy, chromium-plated; with provision for padlock such that handle case serves as protective strike.
- D. Locks: Flat key lever tumbler type for flush mounting; spring bolt action with master key.
- E. Hinges: Provide manufacturer's standard hinge type for each locker configuration
- F. Silencers: Rubber. Provide to minimize noise wherever metal strikes against metal.
- G. Number Plates: Polished aluminum with black numbers 1/2-inch high.
- H. Hooks: Steel with ball points.
- I. Exposed Fasteners: Rustproof. Where bolts are exposed, provide slotless head type with shakeproof washers.
- J. Seismic Anchors: Provide two 1/4 inch diameter "Tek" screws at top and bottom of each full height locker, or tier of lockers.

2.5 METAL LOCKER FABRICATION

- A. Preparation: Verify dimensions at job site.
- B. Frames:
 - 1. Make faces flush without overlapping cross-members; weld joints.
 - 2. Provide door strike and silencers where necessary to curtail noise of closing.
- C. Bodies:
 - 1. Form sheets as necessary for tight joints and rigid body.
 - 2. Rivet or bolt sheets to each other and frames.
- D. Doors:
 - 1. Form at least 1 right angle flange continuous on 4 sides.
 - 2. Provide integral louvers where noted; louver profile as standard with approved manufacturer.

- E. Dust Covers: Typical at all locations; minimize joints; reinforce where required; and provide closures for open ends where occurring.
- G. Seismic Reinforcing: Weld each end of a plate 2 inches by 20 gauge by full width of locker to interior of each locker, or tier of lockers, at top and bottom anchorage points.
- H. Number Plates: Rivet on in approved order starting from No. [1] at each room containing lockers.

2.6 FINISHES

- A. Steel: After forming and welding, thoroughly clean, phosphatize, electrostatically apply heavy coat high quality enamel, baked-on; color as shown on Color Schedule.
- B. Wood: Factory-applied clear polyurethane lacquer.
- C. Exposed Fasteners: Same as steel or noncorrosive white metal finish.

PART 3 - EXECUTION

3.1 EXAMINATION

- A. Examine areas to receive lockers and benches and verify that:
 - 1. Bases not included in work of this section have been properly prepared.
 - 2. Seismic backing plates in stud partitions which are not included in work of this section are correct.
- B. Do not start work until unsatisfactory conditions have been corrected.

3.2 INSTALLATION

- A. Assemble and install lockers and benches in accordance with approved manufacturer's specifications and approved shop Drawings.
- B. Set lockers in place such that they are accurately aligned, level, plumb, and flush with planes of adjacent surfaces.
- C. Anchor lockers to floors and walls as recommended by manufacturer and specified herein.
 - 1. Install seismic anchors through seismic reinforcing plates.
 - 2. Provide seismic anchorage as indicated on Drawings.
- D. Install recess trim to recessed lockers using concealed fasteners. Provide

hairline joints and concealed splice plates.

- E. Install sloping top units (dust covers) to lockers using concealed fasteners. Provide hairline joints and concealed splice plates.
- F. Install finished end panels to conceal exposed ends of non-recessed lockers.

3.3 CLEANING AND ADJUSTMENT

- A. Comply with requirements of Section 017900 - Cleaning.
- B. Adjust locker doors and latches to assure proper operation.
- C. Protect lockers from damage, abuse, dust, dirt, stain, or paint. Do not permit use of during construction.

END OF SECTION

SECTION 10 51 23 - PLASTIC-LAMINATE-CLAD LOCKERS

PART 1 - GENERAL

1.1 RELATED DOCUMENTS

- A. Drawings and general provisions of the Contract, including General and Supplementary Conditions and Division 01 Specification Sections, apply to this Section.

1.2 SUMMARY

- A. Section includes plastic-laminate-clad wood lockers.

1.3 ACTION SUBMITTALS

- A. Product Data: For each type of product.
 - 1. Include construction details, material descriptions, dimensions of individual components and profiles, and finishes for each type of locker.
- B. Shop Drawings: For plastic-laminate-clad wood lockers.
 - 1. Include plans, elevations, sections, and attachment details.
 - 2. Show details full size.
 - 3. Show locations and sizes of furring, blocking, and hanging strips, including concealed blocking and reinforcement specified in other Sections.
 - 4. Show locations and sizes of cutouts and holes for items installed in lockers.
 - 5. Show locker fillers, trim, base, sloping tops, and accessories.
 - 6. Show locker identification system and numbering sequence.
- C. Samples for Initial Selection: For each type of the following:
 - 1. High-pressure decorative laminates.
 - 2. Thermoset decorative overlay panels.
 - 3. Carpet.
- D. Samples for Verification: For the following products:
 - 1. Plastic-laminate-clad panels, not less than 8 by 10 inches, for each type, color, pattern, and surface finish.
 - 2. Thermoset decorative-overlay-surfaced panels, not less than 8 by 10 inches, for each type, color, pattern, and surface finish.
 - 3. Exposed cabinet hardware and accessories, one unit for each type and finish.

1.4 CLOSEOUT SUBMITTALS

- A. Maintenance Data: For adjusting, repairing, and replacing locker doors and latching mechanisms to include in maintenance manuals.

1.5 DELIVERY, STORAGE, AND HANDLING

- A. Do not deliver lockers until painting and similar operations that could damage lockers have been completed in installation areas. If lockers must be stored in other-than-installation areas, store only in areas where environmental conditions are the same as those in final installation location, and comply with requirements specified in "Field Conditions" Article.

1.6 FIELD CONDITIONS

- A. Environmental Limitations: Do not deliver or install lockers until building is enclosed, wet-work is complete, and HVAC system is operating and maintaining temperature between 60 and 90 deg F and relative humidity between 43 and 70 percent during the remainder of the construction period.
- B. Field Measurements: Where lockers are indicated to fit to other construction, verify dimensions of other construction by field measurements before fabrication, and indicate measurements on Shop Drawings.
 - 1. Locate concealed framing, blocking, and reinforcements that support lockers by field measurements before being enclosed, and indicate measurements on Shop Drawings.
- C. Established Dimensions: Where lockers are indicated to fit to other construction, establish dimensions for areas where lockers are to fit. Provide allowance for trimming at site, and coordinate construction to ensure that actual dimensions correspond to established dimensions.

1.7 COORDINATION

- A. Coordinate sizes and locations of concealed wood support bases.
 - 1. Requirements are specified in Section 061000 "Rough Carpentry."
- B. Coordinate sizes and locations of framing, blocking, furring, reinforcements, and other related units of work specified in other Sections to ensure that lockers can be supported and installed as indicated.
- C. Hardware Coordination: Distribute copies of approved hardware schedule specified in Section 087100 "Door Hardware" to fabricator of lockers; coordinate Shop Drawings and fabrication with hardware requirements.

1.8 WARRANTY

- A. Special Warranty: Manufacturer agrees to repair or replace components of lockers that fail in materials or workmanship within specified warranty period.
1. Failures include, but are not limited to, the following:
 - a. Structural failures.
 - b. Faulty operation of locks or hardware.
 - c. Deterioration of wood, finishes, and other materials beyond normal use.
 2. Warranty Period: Three years from date of Substantial Completion.

PART 2 - PRODUCTS

2.1 PERFORMANCE REQUIREMENTS

- A. Accessibility Standard: For lockers indicated to be accessible, comply with applicable provisions in comply with applicable provisions in ICC A117.1 and 2010 ADA Standards for Accessible Design.

2.2 PLASTIC-LAMINATE-CLAD WOOD LOCKERS

- A. Manufacturers:
1. Ideal Lockers
 2. Legacy Lockers
 3. Salsbury Industries
 4. Summit Lockers
 5. Approved Equals
- B. Construction Style: Manufacturer's standard
1. Reveal Dimension: 1/2 inch (13 mm).
- C. Final Assembly: Manufacturer's standard assembly.
- D. Locker Body: Fabricated from particleboard -core panels covered on both sides with thermoset decorative overlay.
1. Side Panels: 3/4 inch thick.
 2. Back Panel: 1/2 inch thick.
 3. Top Panel: 3/4 inch thick.
 4. Bottom Panel: 3/4 inch thick.
 5. Exposed Panel Edges: 3-mm-thick PVC to match panels].
- E. Plastic-Laminate-Clad Wood Doors: High-pressure decorative laminate, Grade VGS, over both sides of medium-density-fiberboard core.
1. Thickness: 3/4 inch thick.

2. Panel Edges: 3-mm-thick PVC to match panels
- F. End Panels: Match style, material, construction, and finish of plastic-laminate-clad wood doors.
- G. Corners and Filler Panels: 3/4-inch thick panels. Match style, material, construction, and finish of plastic-laminate-clad wood doors.
- H. Continuous Finish Base: Plastic-laminate-clad, 3/4-inch thick panel that matches door faces; fabricated in lengths as long as practical to enclose base and base ends of lockers.
- I. Continuously Sloping Tops: Plastic-laminate-clad, 3/4-inch thick panel that matches door faces for installation over lockers with separate flat tops. Fabricate tops in lengths as long as practical, without visible fasteners at splice locations. Provide fasteners, supports, and closures, as follows:
 1. Closures: Vertical type.
 2. Sloping-top corner fillers, mitered.
- J. Plastic-Laminate Colors, Patterns, and Finishes:
 1. As specified in finish schedule

2.3 MATERIALS

- A. Composite Wood: Provide materials that comply with requirements of referenced quality standard for each type of woodwork and quality grade specified unless otherwise indicated.
 1. Thermoset Decorative Panels: Particleboard or medium-density fiberboard finished with thermally fused, melamine-impregnated decorative paper and complying with requirements of NEMA LD 3, Grade VGL, for Test Methods 3.3, 3.4, 3.6, 3.8, and 3.10.
 2. Medium-Density Fiberboard: ANSI A208.2, Grade 130
 3. Particleboard: ANSI A208.1, Grade M-2
 4. Softwood Plywood: DOC PS 1, medium-density overlay.
- B. High-Pressure Decorative Laminate: NEMA LD 3, grades as follows:
 1. Horizontal Surfaces: Grade HGS
 2. Vertical Surfaces: Grade HGS
- C. Furring, Blocking, Shims, and Hanging Strips: Softwood or hardwood lumber, kiln dried to less than 15 percent moisture content.
- D. Anchors: Material, type, size, and finish as required for each substrate for secure anchorage. Provide metal expansion sleeves or expansion bolts for post-installed anchors. Use nonferrous-metal or hot-dip galvanized anchors and inserts at inside face of exterior walls and at floors.
- E. Wood Support Base: 2-by-4-inch nominal-size lumber treated with manufacturer's standard preservative-treatment, nonpressure process.

2.4 HARDWARE

- A. Cam Padlock Hasp: Surface mounted, steel; finished to match other locker hardware.
- A. Keyless Security Locks :
 - a. Keyless access
 - b. Four digit code
 - c. Power: Operates on two 1.5V AAA batteries
 - d. Operation: 15,000 openings
 - e. Low battery signal with battery failure override
 - f. Dimensions: 5-3/8 inches long by 1-1/4 inches wide by 1-3/16 inches deep to top of handle
 - g. Color: Selected by Architect
 - h. Public/private function
 - i. Base Product: Kit-Lock KL1000 by Codelocks Ltd.
- B. Semiconcealed Hinges: Single-pivot, spring-loaded steel hinges; back mounted.
 - 1. Provide two hinges for doors 36 inches high and less.
 - 2. Provide three hinges for doors more than 36 inches high.
- C. Wire Pulls: Back mounted; 5 inches long, 2-1/2 inches deep, and 5/16 inch in diameter.
- D. Shelf Rests: BHMA A156.9, B04013.
- E. Hooks: Manufacturer's standard, ball-pointed aluminum or steel; finished to match other locker hardware. Attach hooks with at least two fasteners.
 - 1. Provide hooks as indicated on Drawings.
 - 2. Provide one double-prong wall hook for each locker.
- F. Exposed Hardware Finish: Satin Nickel unless otherwise indicated.

2.5 ACCESSORIES

- A. Number Identification Plates: 1-1/2-inch- diameter, etched, embossed, or stamped, plates with black numbers and letters at least 1/2 inch (13 mm) high. Identify lockers in sequence indicated on Drawings. Finish plates to match other locker hardware.

2.6 FABRICATION

- A. Fabricate each locker with shelves, an individual door and frame, an individual top, a bottom, and a back, and with common intermediate uprights separating compartments.
 - 1. Fabricate lockers to dimensions, profiles, and details indicated.
 - 2. Ease edges of corners of solid-wood members to 1/16-inch (1.5-mm) radius.
- B. Fabricate lockers square, rigid, without warp, and with finished faces flat and free of dents, scratches, and chips. Accurately factory machine components for attachments. Make joints tight and true.

1. Fabricate lockers using manufacturer's standard construction, with joints made with dowels, dados, or rabbets. Dado side panels to receive shelving except where indicated to be adjustable.
 2. Fabricate lockers with joints that are dadoed or rabbeted, glued full length, and stapled. Dado side panels to receive shelving except where indicated to be adjustable.
- C. Accessible Lockers: Fabricate as follows:
1. Locate bottom shelf no lower than 15 inches above the floor.
 2. Where hooks, coat rods, or additional shelves are provided, locate no higher than 48 inches above the floor.
- D. Venting: Fabricate lockers with space between doors and locker assembly of not less than 1/4 inch (6 mm), with painted metal security screen attached to each shelf between doors.
- E. Number Identification Plates: Inlay number plates flush in each locker door, near top, centered.
- F. Complete fabrication, including assembly, finishing, and hardware application, to maximum extent possible, before shipment to Project site. Disassemble components only as necessary for shipment and installation. Where necessary for fitting at site, provide ample allowance for scribing, trimming, and fitting.
1. Trial fit assemblies at fabrication shop that cannot be shipped completely assembled. Install dowels, screws, bolted connectors, and other fastening devices that can be removed after trial fitting. Verify that the parts fit as intended, and check measurements of assemblies against field measurements indicated on Shop Drawings before disassembling for shipment.
 2. Use only manufacturer's nuts, bolts, screws, and other devices for assembly.
- G. Shop cut openings, to maximum extent possible, to receive hardware, electrical work, and similar items. Locate openings accurately and use templates or roughing-in diagrams to produce accurately sized and shaped openings. Sand edges of cutouts to remove splinters and burrs.
- H. Attach PVC edging to panels by thermally fusing edging to panels after panel fabrication.

PART 3 - EXECUTION

3.1 EXAMINATION

- A. Examine walls and floors or support bases, with Installer present, for compliance with requirements for installation tolerances and other conditions affecting performance of the Work.
- B. Verify that furring is attached to concrete and masonry walls that are to receive lockers.

- C. Proceed with installation only after unsatisfactory conditions have been corrected.

3.2 PREPARATION

- A. Condition lockers to average prevailing humidity conditions in installation areas before installation.
- B. Before installing lockers, examine factory-fabricated work for completeness and complete work as required, including removal of packing.

3.3 INSTALLATION

- A. Install wood support base.
- B. Knocked-Down Lockers: Assemble with manufacturer's standard fasteners, with no exposed fasteners on face frames.
- C. Install lockers level, plumb, and true; use concealed shims.
- D. Connect groups of lockers together with manufacturer's standard fasteners, through predrilled holes, with no exposed fasteners on face frames. Fit lockers accurately together to form flush, tight, hairline joints.
- E. Install lockers without distortion so doors and drawers fit openings properly and are accurately aligned. Adjust hardware to center doors and drawers in openings, providing unencumbered operation. Complete installation of hardware and accessory items as indicated.
 - 1. Installation Tolerance: No more than 1/8 inch in 96-inch (3 mm in 2400-mm) sag, bow, or other variation from a straight line. Shim as required with concealed shims.
- F. Locker Anchorage: Fasten lockers through back, near top and bottom, at ends with No. 8 flush-head wood screws sized for 1-inch (25-mm) penetration into wood framing, blocking, or furring and spaced not more than 16 inches (400 mm) o.c.
- G. Scribe and cut corner and filler panels to fit adjoining work using fasteners concealed where practical. Repair damaged finish at cuts.
- H. Attach sloping-top units to lockers, with end panels covering exposed ends.
- I. Install number identification plates after lockers are in place.
 - 1. Attach number identification plate on each locker door, near top, centered, with at least two screws with finish matching the plate.

3.4 ADJUSTING

- A. Clean, lubricate, and adjust hardware. Adjust doors to operate easily without binding.

3.5 PROTECTION

- A. Protect lockers from damage, abuse, dust, dirt, stain, or paint. Do not permit use during construction.
- B. Touch up marred finishes, or replace lockers that cannot be restored to factory-finished appearance. Use only materials and procedures recommended or furnished by locker manufacturer.

END OF SECTION

SECTION 12 22 20 - CURTAINS AND TRACKS**PART 1 - GENERAL****1.01 SUMMARY**

- A. Provide cubicle curtains and tracks for the following applications.
 - 1. Patient Bays.
 - 2. Patient Rooms.
 - 3. Exam Rooms
- B. Provide shower curtains at Patient and staff shower areas.
- B. Related Work:
 - 1. Section 09 21 16 - Gypsum Board Assemblies, for wallboard ceilings.
 - 2. Section 09 51 00 - Acoustical Ceilings, for acoustical ceiling panels.

1.02 SUBMITTALS

- A. Product Data: Submit manufacturer's product data, installation and maintenance instructions.
- B. Verification Samples: Submit representative of curtain fabric specified to verify style and color.
- C. Shop Drawings: Submit reflected ceiling plans indicating locations of cubicle curtain and tracks.

1.03 QUALITY ASSURANCE

- A. Flammability: Curtains shall pass NFPA 701 - Standard Methods of Fire Tests for Flame Propagation of Textiles and Films.
- B. Mock-Ups: Install one complete unit for approval prior to installation of remaining cubicle curtains and tracks. Approved mock-ups may remain in place.

1.04 DELIVERY, STORAGE, AND HANDLING

- A. Deliver materials and products in unopened factory labeled packages. Store and handle in strict compliance with manufacturer's instructions and recommendations.

PART 2 – PRODUCTS**2.01 MANUFACTURER – PRIVACY CURTAINS**

- A. Subject to compliance with the requirements listed, provide cubicle curtains from the following manufacturer:

1. C/S Cubicle Curtains, a Division of Construction Specialties, Inc.
3 Werner Way
Lebanon, NJ 08833
P: (908) 849-4000 / F: (908) 849-4398
CCInfo@c-sgroup.com
www.c-sgroup.com

2.02 MATERIALS

- A. Curtain Tracks:
 - a. Provide On the Right Track, Inc. cubicle curtain and track system as manufactured by C/S Cubicle Curtains with the following characteristics:
 1. Surface Mounted Track: Extruded aluminum with powder coated white finish.
 2. Dimensions: 1 ½ inches (39 mm) high by 3/8 inch (10 mm) wide.
 3. Provide straight and bent sections as indicated on drawings
 4. Track Accessories: Splices, connectors, hangers, anchors and mounting plates as required
 5. Curtain Loading Tool: Provide manufacturer's standard loading tool, The Grabber.
- B. Cubicle Curtains: As fabricated by on the right track systems, inc. Curtains to be custom made from flame-retardant, hospital quality material with a 1-1/2 IN triple hem, including turned edges and a row of stitches at top and bottom of hem, complete with label. Curtains to be fabricated with nylon mesh tops designed for attachment to track without separate hooks.
 1. Fabric color: As indicated on Interior Finish Schedule.
 2. Vertical Seams: Shall be double needle interlocked.
 3. Label: Shall be sewn into the top hem of each curtain to identify the width of curtain.
 4. Mesh Tops: Flameproof nylon mesh, mesh must have 1/2 IN spacing as per NFPA requirements. Mesh is to be completely bound with same fabric as the body of the curtain. Mesh to be 19 IN high at top of curtains.
 5. Field verify dimensions prior to installation to provide complete enclosure.
 6. Manufacture curtains to length to plus or minus 1 IN tolerance. Fabricate in full size units to meet track width plus 10 percent fullness.
 7. Curtains to finish 12 IN above finished floor.
- C. Pattern & Color:

Cubicle Curtain Fabric: Designer fabric pattern and color as indicated on drawings.
See finish plans.

2.03 MANUFACTURER – SHOWER CURTAINS

- B. Subject to compliance with the requirements listed, provide cubicle curtains from the following manufacturer:
2. Inpro Architectural Products, Commercial Shower Curtains
S80 W18766 Apollo Drive, Muskego, WI 53150
P: (800) 222-5556 / F: (888) 715-8407
mdrago@inprocorp.com, www.inprocorp.com

2.04 MATERIALS

- D. Shower Curtain Tracks:
- a. Provide Clickeze shower curtain and track system as manufactured by Inpro Cubicle Curtains with the following characteristics:
6. Surface Mounted Track: Extruded aluminum with powder coated white finish.
 7. Dimensions: 1 ½ inches (39 mm) high by 3/8 inch (10 mm) wide.
 8. Provide straight and bent sections as indicated on drawings
 9. Track Accessories: Splices, connectors, hangers, anchors and mounting plates as required
 10. Curtain Loading Tool: Provide manufacturer's standard loading tool, The Grabber.
- E. Shower Curtain:
- a. Fabric: Non-woven, antimicrobial, flame retardant and liquid repellent.
 - b. Style: Shield by Panaz (Inpro).
 - c. Color: Color as indicated on drawings.

2.03 FABRICATION

1. Vertical Curtain Seams: Shall be double needle interlocked.
2. Label: Shall be sewn into the top hem of each curtain to identify the width of curtain.
3. Mesh Tops: Flameproof nylon mesh, mesh must have ½" spacing as per NFPA requirements. Mesh is to be completely bound with same fabric as the body of the curtain. Mesh to be 19" high at top of curtains.
 - a. Curtains to finish
12" above the finished floor.
 - b. Panel Size:
Curtains to be fabricated in full size units to meet track widths plus 10% fullness

PART 3 - EXECUTION

3.01 INSTALLATION

- A. Installation of Shower Cubicle Curtains and Tracks: Install in accordance with manufacturer's recommendations, including the following:
1. Verify that ceilings are suitable for installation prior to installation.
 2. Mechanically attach tracks using manufacturer's recommended anchors and attachment devices.
 3. Install accessories and curtains and test for proper operation. Replace damaged units.

END OF SECTION

SECTION 12 24 14 – ROLLER SHADES

PART 1 GENERAL

1.1 SECTION INCLUDES

- A. Manually operated double roller shades.
- B. Electrically operated double roller shades.

1.2 RELATED SECTIONS

- A. Section 06 10 00 - Rough Carpentry: Wood blocking and grounds for mounting roller shades and accessories.
- B. Section 09 29 00 - Gypsum Board Assemblies: Coordination with gypsum board assemblies for installation of shade pockets, closures, and related accessories.
- C. Section 09 51 13 - Acoustical Ceilings: Coordination with acoustical ceiling systems for installation of shade pockets, closures, and related accessories.
- D. Division 26 - Electrical: Electric service for motor controls.

1.3 REFERENCES

- A. ASTM G 21 - Standard Practice for Determining Resistance of Synthetic Polymeric Materials to Fungi.
- B. NFPA 70 - National Electrical Code.
- C. NFPA 701-99 - Fire Tests for Flame-Resistant Textiles and Films.

1.4 SUBMITTALS

- A. Submit under provisions of Section 01 33 00.
** NOTE TO SPECIFIER ** Delete paragraph below if EcoVeil is NOT being specified.
- B. Submit Environmental Certification and Third Party Evaluation per Section 1.5 Qualifications.
- C. Product Data: Manufacturer's data sheets on each product to be used, including:
 - 1. Preparation instructions and recommendations.
 - 2. Styles, material descriptions, dimensions of individual components, profiles, features, finishes and operating instructions.
 - 3. Storage and handling requirements and recommendations.
 - 4. Mounting details and installation methods.
 - 5. Typical wiring diagrams including integration of motor controllers with building management system, audiovisual and lighting control systems as applicable.
- D. Shop Drawings: Plans, elevations, sections, product details, installation details, operational clearances, wiring diagrams and relationship to adjacent work.

1. Prepare shop drawings on Autocad or Microstation format using base sheets provided electronically by the Architect.
- E. Window Treatment Schedule: For all roller shades. Use same room designations as indicated on the Drawings and include opening sizes and key to typical mounting details.
- F. Selection Samples: For each finish product specified, one set of shade cloth options and aluminum finish color samples representing manufacturer's full range of available colors and patterns.
- G. Verification Samples: For each finish product specified, one complete set of shade components, unassembled, demonstrating compliance with specified requirements. Shadecloth sample and aluminum finish sample as selected. Mark face of material to indicate interior faces.
- H. Maintenance Data: Methods for maintaining roller shades, precautions regarding cleaning materials and methods, instructions for operating hardware and controls.

1.5 QUALITY ASSURANCE

- A. Manufacturer Qualifications: Obtain roller shades through one source from a single manufacturer with a minimum of twenty years experience in manufacturing products comparable to those specified in this section.
- B. Installer Qualifications: Installer trained and certified by the manufacturer with a minimum of ten years experience in installing products comparable to those specified in this section.
- C. Fire-Test-Response Characteristics: Passes NFPA 701-99 small and large-scale vertical burn. Materials tested shall be identical to products proposed for use.
- D. Electrical Components: NFPA Article 100 listed and labeled by either UL or ETL or other testing agency acceptable to authorities having jurisdiction, marked for intended use, and tested as a system. Individual testing of components will not be acceptable in lieu of system testing.
- E. Anti-Microbial Characteristics: 'No Growth' per ASTM G 21 results for fungi ATCC9642, ATCC 9644, ATCC9645.
- F. Environmental Certification: Submit written certification from the manufacturer, including third party evaluation, recycling characteristics, and perpetual use certification as specified below. Initial submittals, which do not include the Environmental Certification, below will be rejected. Materials that are simply 'PVC free' without identifying their inputs shall not qualify as meeting the intent of this specification and shall be rejected.
- G. Third Party Evaluation: Provide documentation stating the shade cloth has undergone third party evaluation for all chemical inputs, down to a scale of 100 parts per million, that have been evaluated for human and environmental safety. Identify any and all inputs, which are known to be carcinogenic, mutagenic, teratogenic, reproductively toxic, or endocrine disrupting. Also identify items that are toxic to aquatic systems, contain heavy metals, or organohalogens. The

material shall contain no inputs that are known problems to human or environmental health per the above major criteria, except for an input that is required to meet local fire codes.

- H. Recycling Characteristics: Provide documentation that the shade cloth can and is part of a closed loop of perpetual use and not be required to be down cycled, incinerated or otherwise thrown away. Scrap material can be sent back to the mill for reprocessing and recycling into the same quality yarn and woven into new material, without down cycling. Certify that this process is currently underway and will be utilized for this project.
- I. Perpetual Use Certification: Certify that at the end of the useful life of the shade cloth, that the material can be sent back to the manufacturer for recapture as part of a closed loop of perpetual use and that the material can and will be reconstituted into new yarn, for weaving into new shade cloth. Provide information on each shade band indicating that the shade band can be sent back to the manufacturer for this purpose.
- J. Mock-Up: Provide a mock-up (manual shades only) of one roller shade assembly for evaluation of mounting, appearance and accessories.
 - 1. Locate mock-up in window designated by Architect.
 - 2. Do not proceed with remaining work until, mock-up is accepted by Architect.

1.6 DELIVERY, STORAGE, AND HANDLING

- A. Deliver shades in factory-labeled packages, marked with manufacturer and product name, fire-test-response characteristics, and location of installation using same room designations indicated on Drawings and in the Window Treatment Schedule.

1.7 PROJECT CONDITIONS

- A. Environmental Limitations: Install roller shades after finish work including painting is complete and ambient temperature and humidity conditions are maintained at the levels indicated for Project when occupied for its intended use.

1.8 WARRANTY

- A. Roller Shade Hardware, Chain and Shadecloth (except EcoVeil™): Manufacturer's standard non-depreciating twenty-five year limited warranty.
 - 1. EcoVeil standard non-depreciating 10-year limited warranty.
- B. Roller Shade Motors and Motor Control Systems: Manufacturer's standard non-depreciating five-year warranty.
- C. Roller Shade Installation: One year from date of Substantial Completion, not including scaffolding, lifts or other means to reach inaccessible areas.

PART 2 PRODUCTS

2.1 MANUFACTURERS

- A. Basis of design: MechoShade Systems, Inc.; 42-03 35th Street, Long Island City, NY 11101. ASD. Tel: (718) 729-2020. Fax: (718) 729-2941. Email: info@mechoshade.com, www.mechoshade.com.

2.2 APPLICATIONS/SCOPE

- A. Roller Shade Schedule:

RS -1: Manual operating, chain drive, solar and blackout double shades ceiling mounted typical at all exterior windows.

Include the following:

- a. Shade pockets.
- b. Fascias.
- c. Room darkening side and sill channels.

2.3 ROLLER SHADES, MANUAL OPERATION AND ACCESSORIES

- A. Shade System; General:
 - 1. Components capable of being removed or adjusted without removing mounted shade brackets, or cassette support channel.
 - 2. Smoothly operation raising or lowering shades.
 - 3. Cradle-to-Cradle certified and listed in C2C (DIR).
- B. Basis of Design: Mecho/5 Two Bracket Side by Side System as manufactured by MechoShade Systems LLC.
 - 1. Description: Manually operated fabric window shades.
 - a. Shade Type: Double Roller.
 - b. Universal drive capability to offset drive chain for reverse or regular roll shades.
 - c. Mounting: Ceiling mounted.
 - d. Size: As indicated on drawings.
 - e. Fabric: As indicated under Shade Fabric article.
 - 2. Brackets and Mounting Hardware: As recommended by manufacturer for mounting indicated and to accommodate shade fabric roll-up size and weight.
 - a. Material: Steel, 1/8 inch (3 mm) thick.
 - b. Double Roller Brackets: Configured for light-filtering and room-darkening shades in one opening.
 - 1) Light-Filtering Fabric: Room-side of opening.
 - 2) Room-Darkening Fabric: Glass-side of opening.
 - c. Multiple Shade Band Operation: Provide hardware as necessary to operate more than one shade band using a single clutch operator.
 - d. Radiused Center Support Brackets: Provide brackets and connectors for radiused window applications.
 - 1) Maximum Offset: Eight degrees on each side for a 16 degree total offset.
 - 3. Roller Tubes:
 - a. Material: Extruded aluminum.
 - b. Size: As recommended by manufacturer; selected for suitability for installation conditions, span, and weight of shades.

- c. Fabric Attachment: Utilize extruded channel in tube to accept vinyl spline welded to fabric edge. Shade band to be removable and replaceable without removing roller tube from brackets or inserting spline from the side of the roller tube.
- d. Roller tubes to be capable of being removed and reinstalled without affecting roller shade limit adjustments.
- 4. Hembars: Designed to maintain bottom of shade straight and flat.
 - a. Style: Full wrap fabric covered bottom bar, flat profile with heat sealed closed ends.
 - 1) Profile: Rectangular.
 - 2) Color: To be selected by Architect from manufacturer's standard color selection.
 - b. Style: _____.
 - c. Room-Darkening Shades: Provide a slot in bottom bar with wool-pile light seal.
- 5. Clutch Operator: Manufacturer's standard material and design integrated with bracket/brake assembly.
 - a. Permanently lubricated brake assembly mounted on an oil-impregnated hub with wrapped spring clutch.
 - b. Brake must withstand minimum pull force of 50 pounds (22.7 kg) in the stopped position.
 - c. Mount clutch/brake assembly on the support brackets, fully independent of the roller tube components.
- 6. Drive Chain: Continuous loop stainless steel beaded ball chain, 95 pound (43 kg) minimum breaking strength. Provide upper and lower limit stops.
- 7. Managed Lift: Maximum required lifting force of 4 pounds (1.8 kg) for single band and multi-band shades up to 30 pounds (13.6 kg) hanging weight.
- 8. Accessories:
 - a. Fascia: Removable extruded aluminum fascia, size as required to conceal shade mounting, attachable to brackets without exposed fasteners.
 - 1) Finish: Baked enamel.
 - (a) Color: White.
 - 1) Single Fascia: Accommodate regular roll shades.
 - 2) Profile: Square.
 - 3) Configuration: Captured, fascia stops at captured bracket end.
 - b. Room-Darkening Channels: Extruded aluminum side and center channels with brush pile edge seals, SnapLoc mounting base, and concealed fasteners. Channels to accept one-piece exposed blackout hembar to assure side light control and sill light control.

2.4 SHADE CLOTH

- A. Visually Transparent Single-Fabric Shade Cloth: MechoShade Systems, Inc., ThermoVeil group, single thickness non-raveling 0.030-inch (0.762 mm) thick vinyl fabric, woven from 0.018-inch (0.457 mm) diameter extruded vinyl yarn comprising of 21 percent polyester and 79 percent reinforced vinyl, in colors selected from manufacturer's available range.
 - 1. Dense Basket Weave: "1500 series", 3 percent open, 2 by 2 dense basket-weave pattern.
 - 2. Color: Selected from manufacturer's standard colors.

- B. Blackout Shade:
 - 1. Classic Blackout Collection
 - 2. Color: Selected from manufacturer's standard colors.

2.5 SHADE BAND

- A. Shade Bands: Construction of shade band includes the fabric, the hem weight, hem-pocket, shade roller tube, and the attachment of the shade band to the roller tube. Sewn hems and open hem pockets are not acceptable.
 - 1. Hem Pockets and Hem Weights: Fabric hem pocket with RF-welded seams (including welded ends) and concealed hem weights. Hem weights shall be of appropriate size and weight for shade band. Hem weight shall be continuous inside a sealed hem pocket. Hem pocket construction and hem weights shall be similar, for all shades within one room.
 - 2. Shade band and Shade Roller Attachment:
 - a. Use extruded aluminum shade roller tube of a diameter and wall thickness required to support shade fabric without excessive deflection. Roller tubes less than 1.55 inch (39.37 mm) in diameter for manual shades, and less than 2.55 inches (64.77 mm) for motorize shades are not acceptable.
 - b. Provide for positive mechanical engagement with drive / brake mechanism.
 - c. Provide for positive mechanical attachment of shade band to roller tube; shade band shall be made removable / replaceable with a "snap-on" snap-off" spline mounting, without having to remove shade roller from shade brackets.
 - d. Mounting spline shall not require use of adhesives, adhesive tapes, staples, and/or rivets.
 - e. Any method of attaching shade band to roller tube that requires the use of: adhesive, adhesive tapes, staples, and/or rivets are not acceptable.

2.6 SHADE FABRICATION

- A. Fabricate units to completely fill existing openings from head to sill and jamb-to-jamb, unless specifically indicated otherwise.
- B. Fabricate shadecloth to hang flat without buckling or distortion. Fabricate with heat-sealed trimmed edges to hang straight without curling or raveling. Fabricate unguided shadecloth to roll true and straight without shifting sideways more than 1/8 inch (3.18 mm) in either direction per 8 feet (2438 mm) of shade height due to warp distortion or weave design. Fabricate hem as follows:
 - 1. Bottom hem weights.
 - 2. Concealed hemtube.
 - 3. Exposed hemtube.
 - 4. Exposed blackout hembar with light seal.
 - 5. Exposed blackout hembar with polybond seal.
- C. Provide battens in standard shades as required to assure proper tracking and uniform rolling of the shadebands. Contractor shall be responsible for assuring the width-to-height (W:H) ratios shall not exceed manufacturer's standards or, in

absence of such standards, shall be responsible for establishing appropriate standards to assure proper tracking and rolling of the shade cloth within specified standards. Battens shall be roll-formed stainless steel or tempered steel, as required.

- D. For railroaded shadebands, provide seams in railroaded multi-width shadebands as required to meet size requirements and in accordance with seam alignment as acceptable to Architect. Seams shall be properly located. Furnish battens in place of plain seams when the width, height, or weight of the shade exceeds manufacturer's standards. In absence of such standards, assure proper use of seams or battens as required to, and assure the proper tracking of the railroaded multi-width shadebands.
- E. Provide battens for railroaded shades when width-to-height (W:H) ratios meet or exceed manufacturer's standards. In absence of manufacturer's standards, be responsible for proper use and placement of battens to assure proper tracking and roll of shadebands.
- F. Blackout shadebands, when used in side channels, shall have horizontally mounted, roll-formed stainless steel or tempered-steel battens not more than 3 feet (115 mm) on center extending fully into the side channels. Battens shall be concealed in a integrally-colored fabric to match the inside and outside colors of the shadeband, in accordance with manufacturer's published standards for spacing and requirements.
 - 1. Battens shall be roll formed of stainless steel or tempered steel and concave to match the contour of the roller tube.
 - 2. Batten pockets shall be self-colored fabric front and back RF welded into the shade cloth. A self-color opaque liner shall be provided front and back to eliminate any see through of the batten pocket that shall not exceed 1-1/2 inches (38.1 mm) high and be totally opaque. A see-through moiré effect, which occurs with multiple layers of transparent fabrics, shall not be acceptable.

2.7 COMPONENTS

- A. Access and Material Requirements:
 - 1. Provide shade hardware allowing for the removal of shade roller tube from brackets without removing hardware from opening and without requiring end or center supports to be removed.
 - 2. Provide shade hardware that allows for removal and re-mounting of the shade bands without having to remove the shade tube, drive or operating support brackets.
 - 3. Use only Delrin engineered plastics by DuPont for all plastic components of shade hardware. Styrene based plastics, and /or polyester, or reinforced polyester will not be acceptable.
- B. Motorized Shade Hardware and Shade Brackets:
 - 1. Provide shade hardware constructed of minimum 1/8-inch (3.18 mm) thick plated steel, or heavier, thicker, as required to support 150 percent of the full weight of each shade.
 - 2. Provide shade hardware system that allows for field adjustment of motor or replacement of any operable hardware component without requiring removal of brackets, regardless of mounting position (inside, or outside mount).

3. Provide shade hardware system that allows for operation of multiple shade bands offset by a maximum of 8-45 degrees from the motor axis between shade bands (4-22.5 degrees) on each side of the radial line, by a single shade motor (multi-banded shade, subject to manufacturer's design criteria).
- C. Manual Operated Chain Drive Hardware and Brackets:
1. Provide for universal, regular and offset drive capacity, allowing drive chain to fall at front, rear or non-offset for all shade drive end brackets. Universal offset shall be adjustable for future change.
 2. Provide hardware capable for installation of a removable fascia, for both regular and/or reverse roll, which shall be installed without exposed fastening devices of any kind.
 3. Provide shade hardware system that allows for removable regular and/or reverse roll fascias to be mounted continuously across two or more shade bands without requiring exposed fasteners of any kind.
 4. Provide shade hardware system that allows for operation of multiple shade bands (multi-banded shades) by a single chain operator, subject to manufacturer's design criteria. Connectors shall be offset to assure alignment from the first to the last shade band.
 5. Provide shade hardware system that allows multi-banded manually operated shades to be capable of smooth operation when the axis is offset a maximum of 6 degrees on each side of the plane perpendicular to the radial line of the curve, for a 12 degrees total offset.
 6. Provide positive mechanical engagement of drive mechanism to shade roller tube. Friction fit connectors for drive mechanism connection to shade roller tube are not acceptable
 7. Provide shade hardware constructed of minimum 1/8-inch (3.18 mm) thick plated steel or heavier as required to support 150 percent of the full weight of each shade.
 8. Drive Bracket / Brake Assembly:
 - a. MechoShade Drive Bracket model M5 shall be fully integrated with all MechoShade accessories, including, but not limited to: SnapLoc fascia, room darkening side / sill channels, center supports and connectors for multi-banded shades.
 - b. M5 drive sprocket and brake assembly shall rotate and be supported on a welded 3/8 inch (9.525 mm) steel pin.
 - c. The brake shall be an over -unning clutch design which disengages to 90 percent during the raising and lowering of a shade. The brake shall withstand a pull force of 50 lbs. (22 kg) in the stopped position.
 - d. The braking mechanism shall be applied to an oil-impregnated hub on to which the brake system is mounted. The oil impregnated hub design includes an articulated brake assembly, which assures a smooth, non-jerky operation in raising and lowering the shades. The assembly shall be permanently lubricated. Products that require externally applied lubrication and or not permanently lubricated are not acceptable.
 - e. The entire M5 assembly shall be fully mounted on the steel support bracket, and fully independent of the shade tube assembly, which may be removed and reinstalled without effecting the roller shade limit adjustments.
- D. Drive Chain: #10 qualified stainless steel chain rated to 90 lb. (41 kg) minimum breaking strength. Nickel plate chain shall not be accepted.

2.7 SHADE MOTOR DRIVE SYSTEM

- A. Quiet Intelligent Encoded Motor System (software, two-way communication and internal communication card): Specifications and design are based on the Intelligent Motor Control System WhisperShade- IQ2 Motor System) as manufactured by MechoShade Systems, Inc. Other systems may be acceptable providing that all of the following performance capabilities are provided. Motor control systems not in complete compliance with these performance criteria shall not be accepted as equal systems.
1. Quiet operation of up to 46 dBA within 3 feet open air.
 2. Upper and lower stopping points (operating limits) of shade bands shall be programmed into motors via a hand held removable program module/ configurator.
 3. Intermediate stopping positions for shades shall allow up to three (3) repeatable and precise aligned positions. **Upper limits to be set so that hem tube stays within side channel.**
 4. Up to 103 available alignment points including 3 user programmable predefined intermediate positions, for a total of 5 defined and aligned positions. All seams on the same switch circuit with the same opening height shall align at each intermediate stopping position.
- D. Wall Switches:
1. IQ switches in 10 button, single gang, low voltage. A secondary control point shall be provided that integrates the nurse with call system/pillow speaker system

2.8 ACCESSORIES

- A. Roller Shade Pocket for recessed mounting in acoustical tile, or drywall ceilings as indicated on the Drawings
1. Provide either extruded aluminum and or formed steel shade pocket, sized to accommodate roller shades, with exposed extruded aluminum closure mount, tile support and removable closure panel to provide access to shades.
 - a. Provide "Vented Pocket" such that there will be a minimum of four 1 inch (25.4 mm) diameter holes per foot allowing the solar gain to flow above the ceiling line.
- B. Fascia
1. Continuous removable extruded aluminum fascia that attaches to shade mounting brackets without the use of adhesives, magnetic strips, or exposed fasteners.
 2. Fascia shall be able to be installed across two or more shade bands in one piece.
 3. Fascia shall fully conceal brackets, shade roller and fabric on the tube.
 4. Provide bracket / fascia end caps where mounting conditions expose outside of roller shade brackets.
 5. Notching of Fascia for manual chain shall not be acceptable.

PART 3 EXECUTION

3.1 EXAMINATION

- A. Do not begin installation until substrates have been properly prepared.
- B. If substrate preparation is the responsibility of another installer, notify Architect of unsatisfactory preparation before proceeding.

3.2 PREPARATION

- A. Clean surfaces thoroughly prior to installation.
- B. Prepare surfaces using the methods recommended by the manufacturer for achieving the best result for the substrate under the project conditions.

3.3 INSTALLATION

- A. Install roller shades level, plumb, square, and true according to manufacturer's written instructions, and located so shade band is not closer than 2 inches (50 mm) to interior face of glass. Allow proper clearances for window operation hardware.
- B. Turn-Key Single-Source Responsibility for Motorized Interior Roller Shades: To control the responsibility for performance of motorized roller shade systems, assign the design, engineering, and installation of motorized roller shade systems, motors, controls, and low voltage electrical control wiring specified in this Section to a single manufacturer and their authorized installer/dealer. The Architect will not produce a set of electrical drawings for the installation of control wiring for the motors, or motor controllers of the motorized roller shades. Power wiring (line voltage), shall be provided by the roller shade installer/dealer, in accordance with the requirements provided by the manufacturer. Coordinate the following with the roller shade installer/dealer:
 - 1. Main Contractor shall provide power panels and circuits of sufficient size to accommodate roller shade manufacturer's requirements, as indicated on the mechanical and electrical drawings.
 - 2. Main Contractor shall coordinate with requirements of roller shade installer/dealer, before inaccessible areas are constructed.
 - 3. Roller shade installer/dealer shall run line voltage as dedicated home runs (of sufficient quantity, in sufficient capacity as required) terminating in junction boxes in locations designated by roller shade dealer.
 - 4. Roller shade installer/dealer shall provide and run all line voltage (from the terminating points) to the motor controllers, wire all roller shade motors to the motor controllers, and provide and run low voltage control wiring from motor controllers to switch/ control locations designated by the Architect. All above-ceiling and concealed wiring shall be plenum-rated, or installed in conduit, as required by the electrical code having jurisdiction.
 - 5. Main Contractor shall provide conduit with pull wire in all areas, which might not be accessible to roller shade contractor due to building design, equipment location or schedule.
- C. Adjust and balance roller shades to operate smoothly, easily, safely, and free from binding or malfunction throughout entire operational range.
- D. Clean roller shade surfaces after installation, according to manufacturer's written instructions.

- E. Engage Installer to train Owner's maintenance personnel to adjust, operate and maintain roller shade systems.

3.4 PROTECTION

- A. Protect installed products until completion of project.
- B. Touch-up, repair or replace damaged products before Substantial Completion.

END OF SECTION