



ADDENDUM

Date Issued:	February 20, 2020
Project:	Ogden School District Highland Jr. High School Kitchen Remodel
Addendum Number:	1

The Contractors submitting proposals on the above captioned project shall be governed by the following addendum, changes and explanations to the drawings and specifications and shall submit their bids in accordance therewith.

Item Number	General Items Description
1	See Addendum from Mechanical Engineer (Olsen & Peterson Consulting Engineers) for required changes.
2	See Addendum from Electrical Engineer (BNA Consulting) for required changes.
3	See Addendum from Food Service Consultant (Jedrzejewski Designs) for required changes.
4	Add the "General Requirements – Ogden School District Board of Education" Bidding Document.
5	The winning bidder shall provide payment & performance bonds as required in Section 63G-6a-1103.
6	All bidders shall submit (3) references for completed projects similar in scope & size to this project.
7	The lowest responsive & responsible bidder will be recommended to the board for approval of this project.
8	Heavy Duty Polyethylene (HPDE) lockers are an approved product substitution for the metal lockers. Locker color to match Finish Schedule in drawings.
9	Add wall mounted Fire Extinguisher, Type K. See attached sheet A114.
10	The answers to the all of the questions posted in SciQuest shall be part of this addendum. Question: Is this project tax exempt? Answer: This project is tax exempt. Ogden School District will provide the winning bidder with the tax exemption document.



Item Number	General Items Description
11	<p>Question: What is the size of the overhead coiling doors?</p> <p>Answer: Each coiling overhead door shall have an opening of 12'-0"W x 5'-4"H. Saw cutting of the existing wall may be required. See attached sheet A114.</p>
12	<p>Question: The doors are not shown on the door schedule and the subs are asking what is wanted.</p> <p>Answer: Each coiling overhead door shall be: aluminum, clear finish, exterior keyed cylinder lock, interior/kitchen thumb turn, manual crank back up, basis of design: Alumatec Pacific.</p>
13	<p>Question: Is the architect wanting a solid door or a open pattern grill? It doesn't say what model of Alumatec Pacific door.</p> <p>Answer: Each coiling overhead door shall be a solid door.</p>
14	<p>Question: Do you have a design and manufacture we are to bid for the quartz counter tops?</p> <p>Answer: The countertop was designed around: Pentalquartz, BQ8810P, Imperio Polished; per the Finish Schedule.</p>
15	<p>Question: The above-grade DWV piping spec list cast iron no-hub as the only option. Keyed note #20 on sheet P112 lists ABS pipe. Which one is correct?</p> <p>Answer: Schedule 40 ABS pipe is acceptable for DWV piping, except for where the dishwasher drains into the floor sink. Because of high temperature dishwasher waste water, piping from that floor sink shall be cast iron and shall extend a minimum of 25 linear feet from the floor sink before transitioning back to ABS.</p>
16	<p>Question: Is all of the sewer in the crawl space to be cast iron or just from the dishwasher waste downstream?</p> <p>Answer: Just the line downstream of the dishwasher.</p>
17	<p>Question: Is the gas line that we are connecting to (Keyed Note #5, sheet P111) a 2 PSI line or a low pressure line?</p> <p>Answer: The gas line is a low pressure gas line.</p>



18	<p>Question: Is there any make-up air feeding the crawl space? The plumber will have to be down there for extended amounts of time and will need to weld pipe down there, too.</p> <p>Answer: No, the crawl space is not mechanically ventilated. There are existing non-mechanical foundation vents scattered along the foundation walls, but that is the extent of any crawl space ventilation. The contractors will need to provide their own temporary mechanical ventilation fans to meet OSHA guidelines for welding in confined spaces. Mechanical ventilation should be of sufficient capacity and so arranged as to produce the number of air changes necessary to maintain welding fumes and smoke within safe limits, as defined by OSHA guidelines.</p>
19	<p>Question: In reviewing the plans I am unable to find actual dimensions for either the 6 grills or the for the window shown in the bottom snip (forgive the crude graphic). Also, are the grills to be brick with a cmu and stud backup as below, or brick two sides or brick with an 8 or 10 or 12" cmu? Also, I can only see one place where the grills mentioned in 4.02 are to be removed are all six of the grills located in that one area? I am figuring that the brick need to be toothed into the existing in each instance - is that correct?</p> <p>Answer: We don't have the exact sizes of the (6) grills or window to be demolished & infilled. The infill is meant to be decided by the contractor with brick (to match existing) at the exterior, insulation, and stud backup (with interior material & finish per plans (and exposed stud backup or plywood finish is acceptable at the (6) grills for the interior of "Storage (E)") being an approved method.</p>

Sheet Number	Drawing Description
Architectural Drawings	
A113	Add wall mounted Fire Extinguisher, Type K, as shown on the plans.
A114	Add coiling overhead door dimensions as shown on the plans.
Plumbing Drawings	
P111	See Addendum from Mechanical Engineer for required changes.
P112	See Addendum from Mechanical Engineer for required changes.
P602	See Addendum from Mechanical Engineer for required changes.
Electrical Drawings	
E002	See Addendum from Electrical Engineer for required changes.
Food Service Drawings	
FS101	
FS102	



Sheet Number	Drawing Description
FS103	
FS104	

Specification Section	Project Manual / Specifications
General Sections	
	General Requirements – Ogden School District Board of Education
Electrical Sections	
	See Addendum from Electrical Engineer for required changes.
Food Service Sections	
	See Addendum from Food Service Consultant for required changes.

Attachments:

- Olsen & Peterson Consulting Engineers Addendum 1
- BNA Consulting Electrical Addendum #1
- Jedrzejewski Designs Addendum #1
- “General Requirements – Ogden School District Board of Education” Bidding Document
- A113 Floor Plan
- A114 Dimension Floor Plan
- P111 Plumbing Plan – Water & Gas
- P112 Plumbing Plan – Waste & Vent
- P602 Plumbing Details
- FS101 Food Service Equipment Plan
- FS102 Food Service Equipment Building Requirement Plan
- FS103 Food Service Equipment Plumbing Requirement Plan
- FS104 Food Service Equipment Electrical Requirement Plan



14 East 2700 South
Salt Lake City, Utah 84115

Phone: (801) 486-4646
Fax: (801) 467-2531

Addendum 1

To: Zeke Zenger
Company: NJRA Architects
From: Paul Laird
Date: February 17, 2020

Project: Highland Jr High Kitchen Remodel
Contract Documents Dated: January 2020
Addendum No: 1
Pages: 2

The following additions, modifications, deletions, clarifications and revisions to the Drawings and/or Specifications shall be considered part of the Contract Documents. Where required, acknowledge receipt of this addendum in the Bid Documents. Failure to acknowledge addenda in the Bid Documents may subject the Bidder to disqualification.

Drawings:

Drawing P111

Added new Hand Wash sink per food service drawing changes.
Added SVB to hose reel per Weber-Morgan Health Dept
Added Reduced Pressure Backflow Preventers for Steamers and Combi Oven Fill lines per Weber-Morgan Health Dept
Added Reduced Pressure Backflow Preventer for MAU-1 drain and fill panel per Weber-Morgan Health Dept
Added MAU-1 drain and fill panel above service sink.
Revised notes 2,3, 24 and added note 29.

Drawing P112

Added new Hand Wash sink per food service drawing changes.
Revised drainage connections for hand Wash sinks.

Drawing P602

Added new SVB vacuum breakers to hose reel detail 5/P602 per Weber-Morgan Health Dept
Revised dimension of SVB vacuum breaker to detail 7/P602 per Weber-Morgan Health Dept

HIGHLAND JR. HIGH SCHOOL KITCHEN REMODEL**Electrical Addendum #1****Issue Date:02/20/2020****CHANGES TO THE SPECIFICATIONS:**

26 0943 Lighting Control Equipment:

1. Add Lutron Electronics to the list of acceptable manufacturers. 2.1(A.)(5) Lutron Electronics

CHANGES TO THE DRAWINGS:

Sheet E002:

1. Panelboard Schedule 'K1':
 - a. Change the breaker at number 14 to 40A. 2Pole, with #8 wire.

PRIOR APPROVAL OF MANUFACTURERS OF ELECTRICAL EQUIPMENT

The following items, trade names, products and manufacturers are approved for bidding. Approval does not relieve the bidder from satisfying the intent of the requirements of drawings, specifications and addenda in every respect. Failure to conform to the design quality and standards specified, established and required may result in later disapproval. If equipment must be disapproved after bidding, supplier shall supply specified equipment at no extra cost to the Owner.

Items are listed generally and specific model number, etc. shall be as submitted. Items submitted but not approved, either did not satisfy the requirements, or showed insufficient data, or arrived after the 8 day deadline established for submittals.

<u>TYPE</u>	<u>SPECIFIED</u>	<u>RMLC APPROVED</u>	<u>SSCO APPROVED</u>	<u>QUANTUM APPROVED</u>	<u>JRC APPROVED</u>	<u>TLC APPROVED</u>
A1	NEWSTAR	CERTOLUX	-	KENALL	LUMINAIRE	ECLIPSE
A1E	NEWSTAR	CERTOLUX	-	KENALL	LUMINAIRE	ECLIPSE
A2	NEWSTAR	CERTOLUX	-	KENALL	LUMINAIRE	ECLIPSE
A2E	NEWSTAR	CERTOLUX	-	KENALL	LUMINAIRE	ECLIPSE
A4	METALUX	VISCOR	DAY-BRITE	-	LITHONIA	ECLIPSE
SL1C	DAY-BRITE	VISCOR	-	METALUX	LITHONIA	ALPHALITE

Additional Manufacturers:

Subject to the contract documents, the following manufacturers have submitted and received approval in name only to bid their respective equipment and/or materials for this project. This approval does not release the manufacturer, their supplier or their representative from full compliance with the project's contract documents. If items, hereafter submitted are non-compliant with the contract documents, the owner reserves the right to reject said items and insist upon and receive, at no additional cost, the equipment and/or materials as originally specified in the contract documents.

Manufacturer	Item(s)	Supplier
Mifab	Grease and Oil Interceptors	CSM Group
Mifab	Floor Drains	CSM Group
Mifab	Floor Sinks	CSM Group
Mifab	Cleanouts	CSM Group
McGuire Mfg	P-traps	CSM Group
McGuire Mfg	Fixture Water Supplies	CSM Group
Modine	Make Up air Units	Long
Carnes	Penthouses	Air Control Products
Air-Rite	Volume Dampers	Air Control Products
American Standard	Flush Valves	McGregor & Associates
American Standard	Toilet Seats	McGregor & Associates
Krueger	Registers, Grilles & Diffusers	Long Bldg Environments
Cook	Penthouse	Long Bldg Environments
Thermaflex	Flexible Duct	Long Bldg Environments
ACME	Ceiling Exhaust Fans	Sabol & Rice Inc
ACME	Roof Mtd Exhaust Fans	Sabol & Rice Inc
Air Rite	Penthouse	Sabol & Rice Inc
Acme	Penthouse	Sabol & Rice Inc
Hastings	Make Up Air Unit	Sabol & Rice Inc
Redd-I	Electric Unit Heater	Sabol & Rice Inc
Nailor	Volume Dampers	Sabol & Rice Inc
Hercules	High Efficiency Taps	Applied Product Solutions
JP Lamborn	Flexible Duct	Applied Product Solutions
United Enertech	Penthouse	Applied Product Solutions
Greenheck	Dampers	Mech Products Intermountain
Greenheck	Duct Access Doors	Mech Products Intermountain
Hercules	High Efficiency Taps	Mech Products Intermountain
Quietflex	Flexible Duct	Mech Products Intermountain
Greenheck	Make Up Air Unit	Mech Products Intermountain
Q-Mark	Electric Unit Heater	Mech Products Intermountain
Heatrex	Electric Unit Heater	Mech Products Intermountain

END OF ADDENDUM NO. 1

GENERAL REQUIREMENTS - OGDEN SCHOOL DISTRICT BOARD OF EDUCATION

Any and all information contained in any and all Project Manual Bidding Documents and/or Technical Specifications sections shall override and nullify any information in this General Requirements.

1. DEFINITIONS

(a) The Contract Documents consist of the Agreement, the General and Supplementary Conditions of the Contract, the Drawings and Specifications, including all modifications thereof incorporated in the documents before their execution. These form the Contract.

(b) The Owner, the Contractor, and the Architect, or pronouns used in place thereof, are those mentioned as such in the Agreement. They are treated through the Contract Documents as if each were in the singular number and masculine gender.

(c) The term "Subcontractor," as employed herein, includes anyone having a direct contract with anyone except the Owner to provide material and/or labor under this contract, and it includes one who furnishes material worked to a special design according to the plans and/or specifications of this work, but does not include one who merely furnishes material not so worked.

(d) The word "Owner," or pronoun used in place thereof, is to designate The Board of Education of Ogden City School District.

(e) The term "work" of the Contractor or Subcontractor includes labor or materials or both.

(f) The applicable laws of the State of Utah shall govern the execution of the work embodied in the contract Documents.

2. CORRELATION AND INTENT OF DOCUMENTS

The Contract Documents are complementary, and what is called for by anyone shall be as binding as if called for by all. The intention of the documents is to include all labor and materials, equipment, and transportation necessary for the proper and complete execution of the work, and equal in quality and workmanship to the highest standards. The Contractor is to abide by and comply with the true intent and meaning of all drawings and specifications taken as a whole; and is not to avail himself, to the detriment of the work, of any manifestly unintentional error or omissions, should any exist. All minor details of work which are not shown on the drawings, as well as such items as are not specifically mentioned in the specifications but are obviously necessary for the proper completion of the work, shall be considered as incidental and as being part of the work.

3. COPIES FURNISHED

Unless otherwise provided in the Contract Documents, the Architect will furnish to the Contractor, free of charge, all copies, up to a maximum of twelve sets of drawings and specifications reasonably necessary for the execution of the work.

4. DIMENSIONS

Where no figures or memoranda are given, the drawings shall be accurately followed according to their scale, but figures or memoranda are to be preferred to the scale, in all cases of difference, and the larger scale details shall take preference over those of smaller scale.

5. DETAIL DRAWINGS AND INSTRUCTIONS

The Architect shall furnish with reasonable promptness, additional instructions, by means of drawings or otherwise, necessary for the proper execution of the work. All such drawings and

GENERAL REQUIREMENTS

instructions shall be consistent with the Contract Documents, true developments thereof, and reasonable inferable therefrom. The work shall be executed in conformity therewith and the Contractor shall do no work without proper drawings and instructions. Any work performed by the Contractor in advance of these drawings and instructions shall be entirely at the Contractor's risk.

6. DRAWINGS AND SPECIFICATIONS ON THE WORK

The Contractor shall keep one copy of all drawings and specifications on the work in good order, available to the Owner, the Architect, and their representatives.

7. OWNERSHIP OF DRAWINGS

All copies of drawings and specifications furnished the Contractor by the Architect are the property of the Architect. They are not to be used by the contractor on other work, and are to be returned to the Architect, upon request, at the completion of the work.

8. SHOP DRAWINGS

The Contractor shall submit to the Architect with such promptness as to cause no delay in his work or in that of any other Contractor, six copies of all shop or setting drawings and schedules required for the work of the various trades; and the Architect shall pass upon them with reasonable promptness, making desired corrections. Said Corrections shall pertain to conformance with the basic design concepts embodied in the Contract Documents. The Contractor shall make any corrections required by the Architect. The Architect shall distribute the corrected drawings as follows: (1) drawing to the Owner and (1) drawing for the Architect.

The Architect's approval of such drawings or schedules shall not relieve the Contractor from responsibility for deviations from drawings or specifications, unless he has in writing, called the Architect's attention to such deviations at the time of submission; and has received the Architect's written approval of such deviation; nor shall it relieve him from responsibility for errors of any sort in shop drawings or schedules.

9. SAMPLES

The Contractor shall furnish to the Architect for approval, all samples as directed. The work shall be in accordance with approved samples.

10. MATERIALS, APPLIANCES, EMPLOYEES

Unless otherwise stipulated, the Contractor shall provide and pay for all materials, labor, water, tools, equipment, transportation, and other facilities and services necessary for the execution and completion of the work.

Unless otherwise specified, all material shall be new, and both workmanship and material shall be of high quality.

The Contractor shall, if required, furnish satisfactory evidence as to the kind and quality of materials. The Contractor shall, at all times, enforce strict discipline and order among his employees, and shall not employ on the work any unfit person or anyone not skilled in the work assigned to him.

11. ROYALTIES AND PATENTS

GENERAL REQUIREMENTS

The Contractor shall pay all royalties and license fees. He shall defend all suits or claims for infringement of any patent rights and shall save the Owner harmless from loss on account thereof.

12. SURVEYS, PERMITS AND REGULATIONS

It shall be the responsibility of the Contractor, to obtain all permits required and provide survey work required.

13. PROTECTION OF WORK AND PROPERTY

The Contractor shall continuously maintain adequate protection of all his work from damage and shall protect the Owner's property from injury or loss arising in connection with this contract. He shall make good any such damage, injury, or loss, except such as may be directly due to errors in the Contract Documents or caused by agents or employees of the Owner. He shall adequately protect adjacent property as provided by law and the Contract Documents.

The Contractor shall take all necessary precautions for the safety of employees on the work and shall comply with all applicable provisions of Federal, State and Municipal safety laws and building codes to prevent accidents or injury to persons on, about, or adjacent to the premises where the work is being performed. He shall erect and properly maintain at all times as required by the conditions and progress of the work, all necessary safeguards for the protection of workmen and the public and shall post danger signs warning against hazardous conditions.

14. INSPECTION OF WORK

The Owner, the Architect, and their representatives shall at all times have access to the work; and the Contractor shall provide proper facilities for such access and for inspection.

If in the specifications, the Owner or the Architect requires any work to be specially tested or approved, the Contractor shall give the Owner and the Architect timely notice of its readiness for inspection. Inspections shall be promptly made, and where practicable, at the source of supply. If any work should be covered up without approval or consent of the Architect, it must, if required by the Architect, be uncovered for examination at the Contractor's expense.

15. SUPERINTENDENCE AND SUPERVISION

The contractor shall keep on his work, during its progress, a competent superintendent, and any necessary assistants, all satisfactory to the Owner and the Architect. The superintendent shall represent the Contractor in his absence, and all directions given to him shall be as binding as if given to the Contractor.

The Contractor shall give efficient supervision to the work, using his best skill and attention. He shall carefully study and compare all drawings, specifications and other instructions, and shall at once report to the Architect any error, inconsistency, or omission which he may discover; but shall not be held responsible for their existence or discovery.

16. CHANGES IN THE WORK

The Owner may order or authorize extra work or make changes in the contract, in which case the contract sum shall be adjusted accordingly, all without invalidating the contract. The conditions of the original contract shall apply to all such work except that the time of completion may be adjusted by the Owner at the time such change is ordered. Except in case of an emergency endangering life or property, no extra work of change shall be made other than as authorized by

GENERAL REQUIREMENTS

a written change order from the Owner. No claim for an addition to the contract sum shall be valid unless so ordered.

Where the Owner has assigned an Architect/Engineer to the project, the Contractor shall submit such proposals to the Architect/Engineer in sufficient number that one copy may be transmitted to the Owner, one to the project inspector, and one retained by the Architect/Engineer. Upon receipt of the proposal they will review it and will respond in writing to the Architect/Engineer their acceptance or rejection of the proposal or any additions or changes that they feel are necessary for acceptance. Upon acceptance of the proposal by all parties a written change order will be issued.

Whenever a request for a change order proposal is received by the Contractor, he shall indicate thereon his proposed price to be added or deducted from the contract sum due to the change, together with his request for any adjustment in time of final completion of the entire contract. This price will be computed on the basis of unit prices stated in the Contract if applicable.

Whenever the unit prices in the Contract do not apply, the Contractor will submit a proposed price which must be supported by full and completely detailed estimates of the cost of the added or omitted work.

1. For added or omitted work by the Prime Contractor (not including unit prices): the Contractor shall furnish to the Owner, a detailed estimate of the actual cost of labor, materials, taxes and equipment required for the performance of such work. Equipment rental rates shall not exceed those shown in the latest EQUIPMENT RENTAL RATE manual established by the Utah State Department of Transportation for use in State financed projects.

2. For added or omitted work by a Subcontractor (not including unit price) the Prime Contractor shall furnish to the Owner a detailed estimate of the actual cost to the subcontractors for labor, materials, taxes and equipment to be used for such work. Each such estimate of the costs shall have added thereto a fee to cover supervision, overhead, bond and profit. The Contractor and Subcontractor agree that a total fixed fee (up to 15%) as added shall be full compensation to cover all costs of supervision, overhead, bond, profit and any other general expenses. It is further agreed that all time extensions to the completion date of the Contract and any costs or changes in the Contract price from any cause whatsoever that may be incurred as a result of the change order(s) are included in the change order as authorized.

17. CLAIMS FOR EXTRA COST

If the Contractor claims that any instructions by drawings or otherwise involve extra cost under this contract, he shall give the Owner and the Architect written notice thereof, within a reasonable time after the receipt of such instructions, and in any event before proceeding to execute the work; and the procedure shall then be as provided for changes in the work. No such claim shall be valid unless so made.

18. DEDUCTIONS FOR UNCORRECTED WORK

If the Owner and the Architect deem it inexpedient to correct work damaged or done not in accordance with the Contract, an equitable deduction from the Contract price shall be made therefore.

19. DELAYS AND EXTENSION OF TIME

GENERAL REQUIREMENTS

If the Contractor shall be significantly delayed at any time in the progress of the work by any act or neglect of the Owner or the Architect, or of any employee of either, or by any separate Contractor employed by the Owner, or by significant changes ordered in the work or by strikes, lockouts, fire, unavoidable casualties, or any causes beyond the Contractor's control; or by any cause which the Owner shall decide to justify the delay; then the time of completion shall be extended by written request from the contractor for such reasonable time as the Owner may decide. No action shall lie against the Owner for damages or other claims due to losses attributable to hindrances or delays from any cause whatsoever, including acts and omissions of the Owner or its agents; however, the Contractor may receive an extension of time in which to complete the work under this Contract as provided above. The right to apply for such an extension of time shall be the exclusive remedy available to the Contractor or any Subcontractor as against the Owner for such loss. Any request for extension of extension of time shall be made to the Owner in writing within seven days from the time of occurrence of cause for delay. In case of a continuing cause of delay, only one claim is necessary.

20. CORRECTION OF WORK BEFORE FINAL PAYMENT

The contractor shall promptly remove from the premises all work condemned by the Owner and/or the Architect as failing to conform to the Contract, whether incorporated or not; and the Contractor shall promptly replace and re-execute his own work in accordance with the Contract and without expense to the Owner and shall bear the expense of making good all work of other Contractors destroyed or damaged by such removal or replacement. If the Contractor does not remove such condemned work within a reasonable time, fixed by written notice, the Owner may have the material removed and stored at the expense of the Contractor.

21. CORRECTION OF WORK AFTER FINAL PAYMENT

Neither the final certificate of payment nor any provision in the Contract Documents nor partial or entire occupancy of the premises by the Owner shall constitute an acceptance of work not done in accordance with the Contract Documents or relieve the Contractor of liability in respect to any express warranties or responsibility for faulty materials or workmanship.

The Contractor shall remedy any defects in the work and pay for any damage to other work resulting therefrom, which shall appear within a period of one year from the date of substantial completion of the work unless a longer period is specified. The Owner will give notice of observed defects with reasonable promptness.

22. THE OWNER'S RIGHT TO DO WORK

If the Contractor should neglect to prosecute the work properly or fail to perform any provision of this Contract, the Owner, after five days written notice to the Contractor may, without prejudice to any other remedy he may have, make good such deficiencies and may deduct the cost thereof from the payment then or thereafter due the Contractor.

23. OWNER'S RIGHT TO TERMINATE CONTRACT

If the Contractor should be adjudged a bankrupt, or if he should make a general assignment for the benefit of his creditors, or if a receiver should be appointed on account of his insolvency, or if he should persistently or repeatedly refuse or should fail, except in cases for which extension of time is granted, to supply enough properly skilled workmen or proper materials, or if he should fail to make prompt payment to Subcontractors, or for material or labor, or persistently disregard laws, ordinances, or the instructions of the Architect and the Owner, or otherwise be guilty of a substantial violation of any provision of the Contract, then the Owner may without prejudice to

GENERAL REQUIREMENTS

any other right or remedy, and after giving the Contractor seven days written notice, terminate the employment of the Contractor and take possession of premises and of all materials, tools and appliances thereon, and finish the work by whatever method the Owner deems expedient. In such cases, the Contractor shall not be entitled to receive any further payment until the work is finished. If the unpaid balance of the Contract sum shall exceed the expense of finishing the work, including compensation for additional administrative services, such excess shall be paid to the Contractor. If such expense shall exceed such unpaid balance, the Contractor shall pay the difference to the Owner.

24. APPLICATION FOR PAYMENTS

The Contractor shall submit an application monthly for progress payments to the Architect for his approval. If the Architect approves the payment, he shall then obtain the approval and signature of the Owner's inspector, if one is assigned to continuous on-the-job inspection, and transmit the application to the Owner for payment. A copy of each month's payment request, with proper schedule of work values listed, shall be posted at the job site by the Contractor. Receipts or other vouchers showing payments for the materials and labor, including payments to subcontractors shall be submitted with the application if required.

If payments are made on valuation of work done, such applications shall be submitted at least ten days before each payment falls due. The Contractor shall, before the first application, submit a schedule of values for the various parts of the work, including quantities, aggregating the total sum of the Contract, divided so as to facilitate payments as outlined above and made out in such form as the Owner, the Architect and the Contractor may agree upon, and supported by such evidence as to its correctness as the Architect and/or the Owner may direct. This schedule, when approved by the Architect and the Owner shall be used as a basis for payment, unless it be found to be in error. In applying for payments, the Contractor shall submit in triplicate a statement based upon this schedule and itemized in such form and supported by such evidence as the architect and/or the Owner may direct, showing his right to the payment claimed.

In making payments to the Contractor for completed work or for materials stored on site, it is understood between the Owner and the Contractor that proportionate parts of such payments will be transmitted to such subcontractors and/or suppliers within ten (10) days after receipt of such payments by the Contractor. The submittal of an application by a Contractor for a progress payment shall constitute prima facie representation by that Contractor that all previous proportionate payments made by the Owner to the Contractor for completed work of subcontractors and/or suppliers have been transmitted to all appropriate subcontractors and/or suppliers for their completed work within ten (10) days after receipt of respective payments.

25. CERTIFICATION AND APPROVAL OF PAYMENTS

If the Contractor has made application for payment as stipulated above, the Architect shall promptly signify to the Owner and the Contractor, in writing, his approval or disapproval of the application as submitted. If the application is disapproved, the Architect shall state, in writing, his reasons for withholding approval.

26. CONTRACTOR'S LIABILITY INSURANCE

The Contractor shall maintain for the duration of this project statutory Workmen's Compensation Insurance. In the event any work is subcontracted, the Contractor shall require the Subcontractor to either obtain said insurance coverage for his (subcontractor's) portion of the work or reimburse the Contractor for providing it. Contractor shall also maintain for the duration of the work a

GENERAL REQUIREMENTS

Comprehensive General and Automobile Liability Policy. Such policies shall protect him from claims for bodily injury, including death, to his employees and all others and from claims for property damage, any and all of which may arise out of or result from the Contractor's operations, whether such operations be by himself or by any subcontractor or by anyone directly or indirectly employed by either of them and he may require similar insurance from his subcontractors in the same manner as set forth above. Contractor and/or subcontractor shall verify his insurance requirements to prevent duplication of insurance costs. Such liability insurance with the following minimum limits shall be maintained:

Bodily Injury	Per Person	Per Occurrence
(a) General Liability Insurance	\$300,000	\$500,000
(b) Automobile Liability Insurance	\$300,000	\$500,000
Property Damage	Per Occurrence	Aggregate
(a) General Liability Insurance	\$100,000	\$300,000
(b) Automobile Liability Insurance	\$100,000	

Contractor shall not begin work until he has obtained all required insurance and certificates of such filed with the Architect and such insurance has been approved by the Owner. This requirement also applies to subcontractors. Approval of insurance shall not relieve or decrease liability of the Contractor.

Insurance required by this Article must be written by a company licensed in Utah at the time the policy is issued; the company must be acceptable to Owner.

Contractor shall not cause any insurance to be canceled or permit it to lapse. Each insurance policy shall contain a clause that the policy cannot be canceled or reduced, restricted or limited during the construction period until ten (10) days after written notice as evidenced by return receipt of registered or certified letter has been given to Contractor, Owner, and Architect. Certificates of insurance shall contain transcripts from policies authenticated by proper office of insurer, evidencing in particular those insured, extent of the insurance, location of and operations to which insurance applies, expiration date and above mentioned notice of cancellation clause.

In the event Owner elects to waive this insurance requirement, the Contractor shall credit the Owner for the amount of any returned premium and the contract price shall be reduced in the amount of the premium returned.

Without invalidating the above paragraphs, the Contractor agrees that he shall at all times protect and indemnify and save harmless the Owner and its agencies and institutions and the Architect and his agents and employees from any and all claims, demands, judgments, expenses, including reasonable attorney's fees and all other damages of every kind and nature made, rendered or incurred, by or in behalf of, any person or corporation whatsoever, including the parties hereto and their employees that may arise, occur or grow out of any acts, actions, work or other activity done by the said Contractor in the performance and execution of this contract.

27. FIRE INSURANCE

Remodel Work: In accordance with current State form, the Owner shall effect and maintain insurance against fire and/or related perils upon the structure(s) on which the work of this contract is to be done.

Payment of Claims: Contractor and/or Owner will be reimbursed for only that portion which the insurance company has an obligation to pay under the terms of the policy.

GENERAL REQUIREMENTS

28. OWNER'S PROTECTIVE LIABILITY INSURANCE

The Contractor shall maintain, during the life of this Contract, complete Owner's Protective Liability Insurance with the Owner and Architect as named insureds in the amounts as follows:

Bodily Injury:	Per person - \$300,000
	Per Occurrence - \$500,000
Property Damage:	Per Occurrence - \$100,000
	Aggregate - \$300,000

Contractor and/or subcontractor shall verify his insurance requirements to prevent duplication of insurance costs.

Contractor shall not begin work until he has obtained all required insurance and certificates of such are approved and filed with the Owner. Approval of insurance shall not relieve or decrease liability of the Contractor.

Insurance required by this Article must be written by a company licensed in Utah at the time the policy is issued; the company must be acceptable to the Owner.

29. GUARANTEE BONDS

The Contractor shall include in his bid, as part of the quoted total, all costs involved in securing and furnishing the following bonds based on the completed cost of the contract:

- a. A full 100% Performance Bond covering the faithful execution of the contract and,
- b. A full 100% Payment Bond of all obligations arising thereunder.

30. LIENS

Neither the final payment nor any part of the retained percentage shall become due until the Contractor, if required, shall deliver to the Owner a complete release of all liens arising out of this contract, or receipts in full in lieu thereof, and, if required in either case, an affidavit that so far as he has knowledge or information the releases and receipts include all the labor and materials for which a lien could be filed; but the Contractor may, if any subcontractor refuses to furnish a release or receipt in full, furnish a bond satisfactory to the Owner, to indemnify him against any lien. If any lien remain unsatisfied after all payments are made, the Contractor shall refund to the Owner all moneys that the latter may be compelled to pay in discharging such a lien, including all costs and a reasonable attorney's fee.

31. ASSIGNMENT

The Contractor shall not assign the contract or sublet it as a whole without the written consent of the Owner, nor shall the Contractor assign any moneys due or to become due to him hereunder, without the previous written consent of the Owner.

32. MUTUAL RESPONSIBILITY OF CONTRACTORS

Should the Contractor cause damage to any separate contractor on the work, the Contractor agrees, upon due notice, to settle with such contractor by agreement or arbitration, if he will so settle. If such separate contractor sues the Owner on account of any damage alleged to have

GENERAL REQUIREMENTS

been so sustained, the Owner shall notify the Contractor, who shall defend such proceedings at his own expense and, if any judgement against the Owner arises therefrom, the Contractor shall pay or satisfy it in its entirety.

33. SEPARATE CONTRACTS

The Owner reserves the right to let other contracts in connection with this work. The Contractor shall afford other contractors' reasonable opportunity for the introduction and storage of their materials and the execution of their work and shall properly connect and coordinate his work with theirs.

If any part of the Contractor's work depends for proper execution or results upon the work of any other contractor, the Contractor shall inspect and promptly report to the Architect and the Owner any defects in such work that render it unsuitable for such proper execution and results. His failure to so inspect and report shall constitute an acceptance of the other contractor's work as fit and proper for the reception of his work, except as to defects which may develop in the other contractor's work after the execution of his work. To ensure the proper execution of his subsequent work, the Contractor shall measure work already in place and shall at once report to the Architect any discrepancy between the executed work and the Drawings.

34. SUBCONTRACTS

The two apparent low bidders shall furnish to the Owner, within twenty-four (24) hours after the opening of bids, a list of the subcontractors by name and amounts where subcontractors' bids are in excess of \$5,000.00 and shall not employ any that the Owner may, within a reasonable time, object to as incompetent or unfit. Bidders shall not list themselves or "self" under any category as subcontractor unless the bidder intends to perform as the subcontractor for which he lists "self," and unless he generally and regularly performs that type of subcontract work. The Architect and/or the Owner shall, on request, furnish to any subcontractor, wherever practicable, evidence of the amounts certified on this account.

The Contractor agrees that he is as fully responsible to the Owner for the acts and omissions of his subcontractors and of persons either directly or indirectly employed by them, as he is for the acts and omissions of persons directly employed by him.

Nothing contained in the contract documents shall create any contractual relation between any subcontractor or supplier and the Owner.

35. RELATIONS OF CONTRACTOR AND SUBCONTRACTOR

The Contractor agrees to bind every subcontractor and every subcontractor agrees to be bound by the terms of the Agreement, the General Conditions, the Drawings and Specifications as far as applicable to his work. Nothing in this article shall create any obligation on the part of the Owner to pay or to see to the payment of any sums to any subcontractor.

36. OWNER'S INSPECTION

The Owner, at his option, may assign a staff inspector to the project. Such staff inspector will cooperate with the Design Architect/Engineer in noting deviations from, or necessary adjustments, to the contract documents, or of deficiencies or defects in the construction. The staff inspector's presence on the project, however, shall in no way relieve the Design Architect/Engineer of the prime responsibilities as set forth herein.

37. ARCHITECT'S STATUS

GENERAL REQUIREMENTS

Neither the Architect or the Owner assumes the responsibility for construction means, methods, techniques, sequences, or procedures, or for safety procedures, precautions and programs employed by the Contractor, Subcontractor, their employees, or any material supplier. The Architect does not guarantee the Contractor's performance or commitment to the Owner.

Any requests for interpretation of the Contract Documents must be submitted to the Architect not later than four (4) working days (not including Saturday, Sunday, or State Holidays) prior to bid opening.

38. ARCHITECT'S DECISIONS

The Architect shall, within a reasonable time, make decisions on all claims of the Owner or Contractor and on all other matters relating to the execution and progress of the work or the interpretation of the contract documents.

39. CASH ALLOWANCES

The Contractor shall include in the contract sum all allowances named in the contract documents and shall cause the work so covered to be done by such contractors and for such sums as the Architect may specify and certify, the contract sum being adjusted in conformity therewith, upon approval of Owner.

40. USE OF PREMISES

The Contractor shall confine his apparatus, the storage of materials and the operations of his workmen to limits indicated by law, ordinances, permit or directions of the Architect and shall not unreasonably encumber the premises with his materials. The Contractor shall not load or permit any part of the equipment or structure to be loaded with a weight that will endanger its safety or the safety of any person on the premises.

41. CUTTING, PATCHING AND DIGGING

The Contractor shall do all cutting, patching, or fitting of his work that may be required to make its several parts come together properly and fit it to receive or to be received by work of other contractors shown upon, or reasonably implied by, the Drawings and Specifications for the completed structure and he shall make good after them as the Architect may direct.

Any cost caused by defective or ill-timed work shall be borne by the party responsible therefor. The Contractor shall not endanger any work, by cutting, digging or otherwise, and shall not cut or alter the work of any other contractor save with the consent of the Architect.

42. CLEANING UP

The Contractor shall at all times keep the premises free from accumulations of waste material or rubbish caused by his employees or work, and at the completion of the work he shall remove all his rubbish from and about the building and all his tools, scaffolding and surplus materials and shall leave his work "boom-clean" or its equivalent, unless more exactly specified. In case of dispute, the Owner may remove the rubbish and charge the cost to the several contractors as the Architect shall determine to be just.

43. SUBSTITUTIONS

GENERAL REQUIREMENTS

Where reference is made to one or more proprietary products but restrictive descriptive material of only one manufacturer is used, it is understood that the products of other manufacturers will be accepted provided they equal or exceed the standards set forth in the drawings and specification and are compatible with the intent and purpose of the design, subject to the written approval of the Owner and the Architect prior to the opening of bids.

Requests for and information pertaining to said approval must be submitted to the Architect no later than four (4) working days (not including Saturday, Sunday or State Holidays) prior to bid opening. If the descriptive material is not restrictive, the products of other manufacturers specified will be accepted without prior approval provided they are compatible with the intent and purpose of the design.

The Contractor may propose the substitution of any material as a supplement to his bid with the monetary amount, additive or deductive as may be the case, clearly stated; manufacturer's information, catalog numbers, and complete descriptive information shall be included with the proposed substitution. This shall be completely apart and separate from the base bid quotation and shall be solely for the information of the Owner and the use of such proposed substitution shall be strictly at the decision of the Owner. If the substitution is accepted by the Owner, the contract sum shall be adjusted from the base bid either up or down as indicated on the supplementary list.

44. LAYING OUT WORK

The contractor shall be held strictly responsible for the accuracy of the laying out of his work and for its strict conformity with the existing conditions of the building, and shall determine all changes and chases and openings before work is commenced.

45. EMERGENCIES

In an emergency affecting the safety of life, or of the structure, or of adjoining property, then the Contractor, without special instruction or authorization from the Architect or the Owner, shall act at his discretion to prevent such threatened loss or injury. Any compensation claimed to be due him therefrom shall be determined as provided for under "Changes in the Work."

46. TESTING OF MATERIALS

In case the Architect shall direct that any materials be tested or analyzed, then the Contractor shall furnish a sample for the test, such sample being selected according to the directions of the Architect. The cost of testing or analysis of such sample or samples shall be borne by the manufacturer or supplier of the product. This provision shall not apply to the testing of concrete.

47. TEMPORARY ENCLOSING, DRYING OUT, ETC

When openings are made in exterior walls, the Contractor shall, if required by the Architect on account of weather or security conditions, close up all exterior openings, (except one or more which are to be provided with battened doors, padlocks, etc.) with temporary frames covered with approved material.

The Contractor must, at all times, protect the building from damage from weather, surface water or subsoil drainage. He must keep the excavations dry, if necessary, by pumping, while concrete or masonry is being laid.

48. EXAMINATION OF SITE

GENERAL REQUIREMENTS

The Contractor shall visit the site of the building and examine for himself the site and soil conditions. He shall furnish all labor and materials necessary for preparation of the site for the execution of this contract.

49. STORAGE AND CARE OF MATERIALS

The Contractor shall provide, maintain and remove when directed, suitable, substantial, watertight storage sheds upon the premises where directed in which he shall store his materials. All cement, lime and other materials affected by moisture shall be covered and protected to keep from damage while it is being transported to the site.

50. BUILDING RISKS

The building and all materials and work connected therewith shall be at the Contractor's risk until they are accepted, and he will be held responsible for and liable for their safety in the amount paid to him by the board on account thereof.

51. TEMPORARY APPURTENANCES AND CONVENIENCES

The Contractor shall provide well-fastened ladders and other means to facilitate inspection of the work.

52. SCAFFOLDING, TOOLS, ETC.

The Contractor shall provide and erect all the necessary platforms, scaffolds, and supports of ample strength required for the handling of the materials and all other loading to be imposed. The same shall apply to all derricks and hoisting machinery, all appliances and materials, ladders, horses, poles, planks, ropes, wedges, centers, moulds, and other tools and materials, and the cartage thereof to and from the building as may become necessary for the performance of his contract.

53. REFUSE

Refuse containers are to be provided by the Contractor for the workmen's lunch boxes and papers.

54. REMOVING WATER

The Contractor shall remove at his expense from all excavations and/or from the building all unwanted water appearing from any cause during any stage of the work, until the building is accepted by the Owner. All excavations shall be free from water before any concreting or other work is done in them.

55. TAXES

The Ogden City School District is exempt from Utah State Sales Tax. The Owner will provide the winning Contractor with State Form TC-721 which will be needed to claim the exemption.

56. CITIZENS PREFERRED

Preference shall be given in hiring citizens of the United States or those having declared their intention of becoming citizens; failure to comply may result in the Owner declaring the contract void.

GENERAL REQUIREMENTS

57. CODE REQUIREMENTS

The provisions of the 2015 International Building Code, with amendments, the 2015 International Mechanical Code with amendments the 2015 International Electrical Code, with amendments, and the 2015 International Plumbing Code shall apply except as specific variances therewith may be authorized by the Owner.

If the Drawings and Specifications fail to meet the minimum standards of the above-mentioned codes, it shall be the responsibility of the Contractor to bring such information to the attention of the Architect or Engineer having jurisdiction. Subcontractors shall also inform the Contractor of any infractions of the above-mentioned codes regarding their own particular trades.

In the event that workmanship or incidental materials are not specified or indicated, they shall at least conform to the above-mentioned codes and shall be incorporated into the work without any additional cost to the Owner. If the drawings and specifications call for items or workmanship which exceed the codes, the drawings and specifications hold precedence over any code requirements.

58. NONDISCRIMINATION AND AFFIRMATIVE ACTION

In order to comply with the provisions of the Utah Anti-Discrimination Act of 1965, relating to unfair employment practices, the Contractor agrees as follows:

- A. The Contractor will not discriminate against any employee or applicant for employment because of race, color, sex, religion, ancestry or national origin.
- B. In all solicitations or advertisements for employees, the contractor will state that all qualified applicants will receive consideration without regard to race, color, sex, religion, ancestry or national origin.
- C. The Contractor will send to each labor union or workers' representative notices to be provided, stating the Contractor's responsibilities under the statute.
- D. The Contractor will furnish such information and reports as requested by the Division for the purpose of determining compliance with the statute.
- E. Failure of the Contractor to comply with the statute, the rules and regulations promulgated there under and this nondiscrimination clause shall be deemed a breach of contract and it may be canceled, terminated or suspended in whole or in part.
- F. The Contractor will include the provisions of Paragraphs A through F in every subcontract or purchase order (unless excepted under the statute or rules and regulations) so that such provisions will be binding upon such subcontractor or vendor.

Monthly Employment Compliance Reports must be submitted to the Owner by the prime contractor and all subcontractors with contracts in excess of \$10,000 at the Owner's option.

The Contractor will take affirmative action to ensure that applicants are employed, and that employees are treated during employment, without regard to their race, color, religion, sex or national origin. Such action shall include, but not be limited to the following: Employment, upgrading, demotion, or transfer; recruitment or recruitment advertising; layoff or termination; rates of pay or other forms of compensation; and selection for training, including apprenticeship.

A written Affirmative Action Program must be submitted to the Owner within thirty (30) days of Notice to Proceed by the prime contractor and all subcontractors with contracts in excess of \$50,000. All exempt contractors should have a program on file and available for review by the Owner upon request.

Guidelines for an affirmative action program are available from the Owner.

GENERAL REQUIREMENTS

At its discretion the Owner may perform a compliance review at the office and project of the Contractor to check on compliance in hiring practices, record keeping, contacting of agencies and unions, advertising, informing of personnel of the requirements under this provision and etc. If the visit to the project site or other information received indicates need to perform a compliance review more frequently on a project, this will be done. The size of the project, compliant situation, and past record of the Contractor in his program will determine the frequency of on-the-job compliance reviews.

Any Deficiencies found in the affirmative action program of the Contractor during either a compliance review or as determined from reports submitted will be discussed with the Contractor and confirmed in writing. The Contractor must then Submit in writing specific commitments to correct such deficiencies.

59. SAFETY

The Contractor shall institute a safety program at the start of construction to minimize accidents, such program to continue to end of the job and conform to the latest general safety orders of the State Industrial Commission, as contained in the Utah Occupational Safety and Health Act of 1973. The manual of Accident Prevention in Construction may be used as a guideline for safety practices. Contractor shall post signs erect barriers, etc., as necessary to implement this program.

The Contractor shall have all workmen and all visitors on site wear safety hard hats and obey all safety rules and regulations and statutes as soon as the Contractor proceeds. The Contractor shall post a sign regarding hats in a conspicuous location and furnish extra hats at his expense for visitors.

60. RUBBISH DISPOSAL

Rubbish, trash, etc., shall not be burned on the premises unless approved by the local fire authority, but rather, hauled from the site and legally disposed of.

61. SUBCONTRACTORS FINANCIAL BID LIMITS AND LICENSE CLASSIFICATION

The Contractor shall verify the license classification and bid limit of each of his subcontractors. Regulations prohibit work of the subcontractors exceeding their respective bid limit and working outside of license classification as determined by the Commission of Business Regulation, Department of Contractors.

In the event that the bid limit or classification is not complied with, the respective subcontractor(s) will be disqualified by the Commission of Business Regulation and the Department of Contractors, and the Contractor shall be responsible to provide a suitable and properly qualified subcontractor as approved by the Owner without a change in the contract price.

62. BALANCING AND TESTING

It is the intent of this specification that the building, when presented to the Owner for final acceptance, be complete and operable in all respects, including, but not limited to mechanical, utilities, and other systems which are tuned, tested, and balanced to the satisfaction of the Architect, or his appropriate Engineers and Consultants; and the Owner. Any and all testing and balancing necessary shall be done as part of the contract.

During, or in connection with, the inspection of the work, the Contractor or appropriate Subcontractor(s) shall perform such tests and/or demonstrations of the operation of the systems, or its components, as may be requested by the Owner and/or Architect or his appropriate

GENERAL REQUIREMENTS

Engineers and Consultants as necessary to adequately determine the acceptability of the installation.

63. SUBSTANTIAL COMPLETION

The Architect and Owner will conduct inspections to determine the Dates of Substantial Completion and final payment; the Architect will receive written guarantees and related documents required by the contract and assembled by the Contractor and submit these to the Owner, and will issue a final Certificate for Payment.

The Date of Substantial Completion of the work or designated portion thereof, is the date certified by the Owner when construction is sufficiently complete in accordance with the contract documents, so the Owner may occupy the work or designated portion thereof for the use for which it is intended. When the Contractor determines that the work or a designated portion thereof acceptable to the Owner is substantially complete, the Owner shall prepare a list of items to be completed or corrected. The failure to include any item on such list does not alter the responsibility of the Contractor to complete all work in accordance with the contract documents.

When the Owner, on the basis of an inspection, determines that this work is substantially complete, the Architect then will prepare a Certificate of Substantial Completion which shall establish a Date of Substantial Completion; shall state the responsibilities of the Owner and the Contractor for maintenance, heat, utilities and insurance, and shall fix the time within which the Contractor shall complete the items listed therein, said time to be within the contract time unless extended pursuant to Article, "Delays and Extension of Time." The Certificate of Substantial Completion shall be submitted to the Owner and the Contractor for their written acceptance of the responsibilities assigned to them in such certificate. The Certificate of Substantial Completion shall be on A.I.A. Form G-704.

If within one year after the Date of Substantial Completion or within such longer period of time as may be prescribed by law or by the terms of any applicable special guarantee required by the Contract documents, if any of the work is found to be defective or not in accordance with the contract documents, the Contractor shall correct it promptly after receipt of written notice from the Owner to do so unless the Owner has previously given the Contractor a written acceptance of such condition. The Owner shall give such notice promptly after discovery of the condition.

64. NON-ASBESTOS MATERIALS

All materials used in the work shall be asbestos-free or shall be certified by independent testing laboratories to contain less asbestos than is allowed by EPA regulations.

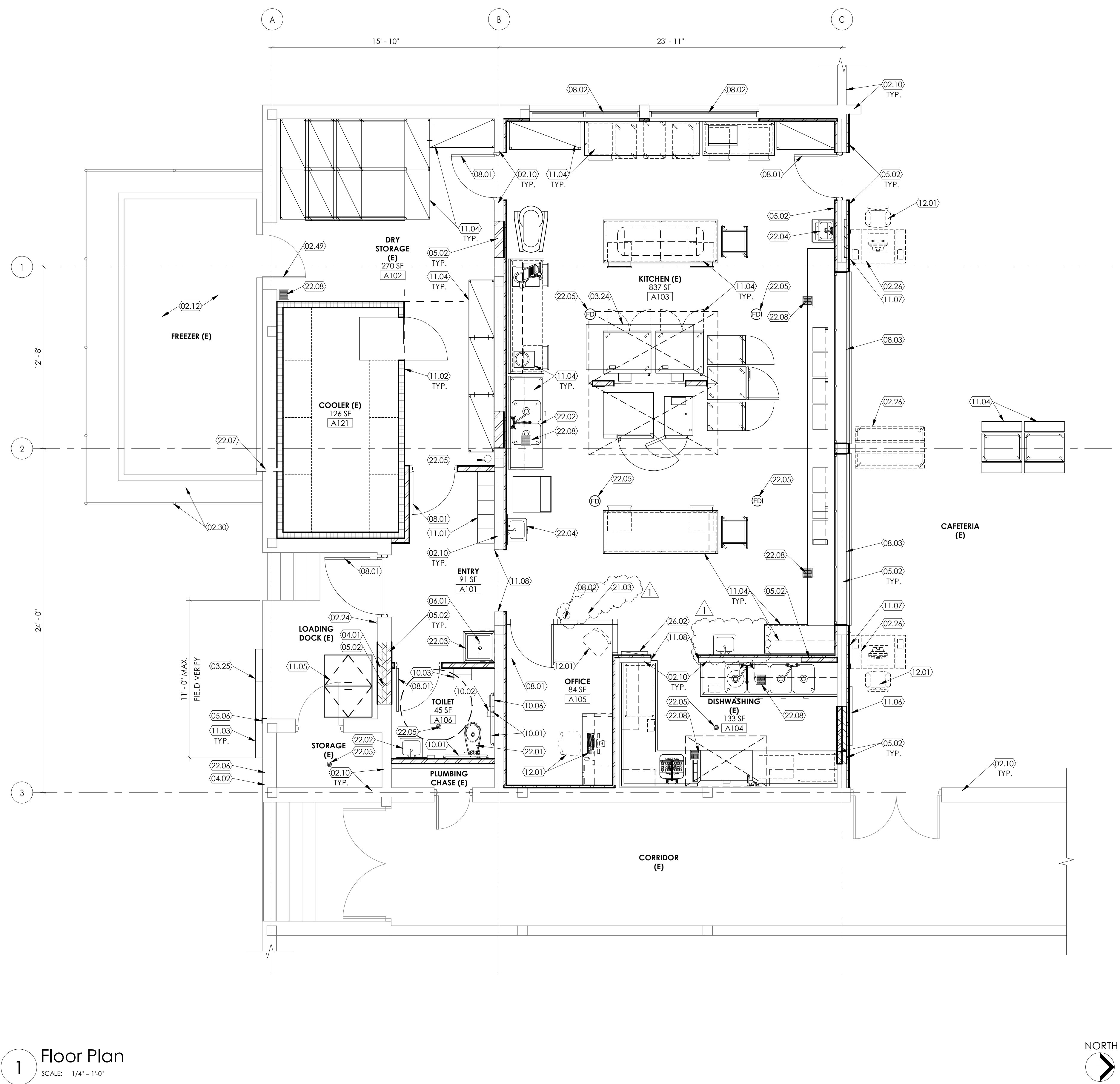
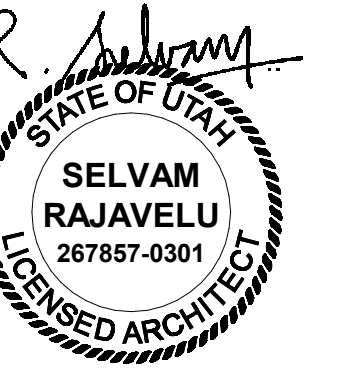

1 Floor Plan
SCALE: 1/4" = 1'-0"

KEYED NOTES

- 02.10 EXISTING WALL TO REMAIN. PROTECT FROM DAMAGE. FIELD VERIFY.
- 02.12 EXISTING FREEZER, DOOR, & FLOOR TO REMAIN. PROTECT FROM DAMAGE. FIELD VERIFY.
- 02.24 EXISTING WALL MOUNTED DOOR BELL TO REMAIN. PROTECT FROM DAMAGE. FIELD VERIFY.
- 02.26 EXISTING KITCHEN EQUIPMENT TO BE RE-USED. PROTECT FROM DAMAGE. FIELD VERIFY. SEE FOOD SERVICE PLANS.
- 02.30 EXISTING CONCRETE PAD & CHAIN LINK FENCE TO REMAIN. PROTECT FROM DAMAGE. FIELD VERIFY.
- 02.32 PATCH & REPAIR FLOOR. SLOPE AS REQUIRED TO EXISTING FLOOR DRAIN. FIELD VERIFY.
- 02.49 EXISTING DOOR TO REMAIN. PROTECT FROM DAMAGE. FIELD VERIFY.
- 03.25 CONCRETE INFILL IN EXISTING CONCRETE WALL. PATCH AND REPAIR EXISTING CONCRETE AS REQUIRED. FIELD VERIFY. SEE STRUCTURAL PLANS.
- 04.01 INFILL EXISTING OPENING WITH MASONRY. TO MATCH EXISTING. COORDINATE WITH ARCHITECT. FIELD VERIFY.
- 04.02 INFILL EXISTING OPENINGS. (6) TOTAL WITH MASONRY TO MATCH EXISTING. COORDINATE WITH ARCHITECT. FIELD VERIFY. SEE MECHANICAL PLANS.
- 05.02 METAL STUD FRAMING. SEE FLOOR PLANS FOR WALL TYPES.
- 05.06 PROVIDE 4" X 4" X 3/8" H STEEL ANGLE, POWDER COATED BLACK, ON EXISTING WALL AS REQUIRED. INSTALL TIGHT TO LOADING DOCK SURFACE. PROTECT EXISTING WALL, LOADING DOCK, ETC. FROM DAMAGE. FIELD VERIFY.
- 06.01 UPPER WALL CABINET. SEE INTERIOR ELEVATION.
- 08.01 DOOR FRAME AND DOOR. SEE DOOR SCHEDULE FOR DOOR SIZE, DOOR ELEVATION, ETC.
- 08.02 WINDOW. SEE WINDOW TYPES FOR SIZE. SEE FLOOR PLAN FOR SILL TYPE.
- 08.03 OVERHEAD COILING DOOR, ELECTRICALLY OPERATED. SEE DOOR SCHEDULE FOR DOOR SIZE. SEE ELECTRICAL DRAWINGS AND SECTION 5/A201.
- 10.01 GRAB BARS. INSTALL PER CODE. SEE SHEET G004.
- 10.02 TOILET PAPER DISPENSER. OWNER FURNISHED, CONTRACTOR INSTALLED. CONTRACTOR SHALL PROVIDE BACKING FOR ALL OWNER FURNISHED ITEMS. INSTALL PER CODE. SEE SHEET G004.
- 10.03 PAPER TOWEL DISPENSER. OWNER FURNISHED, CONTRACTOR INSTALLED. CONTRACTOR SHALL PROVIDE BACKING FOR ALL OWNER FURNISHED ITEMS. INSTALL PER CODE. SEE SHEET G004.
- 10.06 SANITARY NAPKIN DISPOSAL. OWNER FURNISHED, CONTRACTOR INSTALLED. CONTRACTOR SHALL PROVIDE BACKING FOR ALL OWNER FURNISHED ITEMS. INSTALL PER CODE. SEE SHEET G004.
- 11.01 LOCKERS. METAL. ON CONCRETE BASE WITH SLOPED DUST TOP. 12"W X 14"D X 60"H (2) TIER. PROVIDE SHELF WITH MULTIPLE HOOKS INSIDE LOCKER. SEE INTERIOR ELEVATIONS. FINISH PLAN AND DETAIL 6/A305.
- 11.02 WALK-IN REFRIGERATOR. SEE KITCHEN DRAWINGS.
- 11.03 DOCK BUMPERS. LAMINATED RUBBER. 10" H X 9" D X LARGEST WIDTH POSSIBLE TO FIT AVAILABLE SPACE. SEE DIMENSION. BLACK POWDER COATED FINISH. BASIS OF DESIGN: CISCO-EAGLE. PROVIDE ANGLES AS REQUIRED. ANCHOR TO EXISTING DOCKY WALL W/ 3/4" X 4 1/4" SLEEVE ANCHOR. OR AS REQUIRED BY MANUFACTURER. COORDINATE W/ ARCHITECT. COORDINATE WITH CONCRETE INFILL WORK BELOW & HOSE BIBB BOX. FIELD VERIFY.
- 11.04 KITCHEN EQUIPMENT. SEE FOOD SERVICE PLANS & SPECIFICATIONS.
- 11.05 40 X 52 MIN. STEEL. BI-FOLD/ BUTTERFLY STYLE. LOCKABLE. HINGED ACCESS HATCH. POWDER BLACK COATED FINISH. DIAMOND PLATE SURFACE. BASIS OF DESIGN: USF FABRICATION. COORDINATE W/ MECH. CONTRACTOR & GREASE WASTER INTERCEPTOR.
- 11.06 REINSTALL DISPLAY BOARD. FIELD VERIFY MOUNTING LOCATION & HEIGHT. COORDINATE W/ OWNER & ARCHITECT AS REQUIRED.
- 11.07 WALL MOUNTED TV. CONTRACTOR TO PROVIDE MOUNTING KIT. TV PROVIDED BY OWNER. COORDINATE WITH OWNER & ARCHITECT. SEE ELECTRICAL PLANS.
- 11.08 STAINLESS STEEL TRIM AT EXISTING OPENINGS. SEE KITCHEN PLANS.
- 12.01 FURNITURE, EQUIPMENT, ETC., N/C. (SHOWN DASHED).
- 21.03 FIRE EXTINGUISHER, CLASS K. PROVIDE WALL BRACKET. INSTALL BELOW WINDOW SILL & PER CODE.
- 22.01 WATER CLOSET. SEE PLUMBING DRAWINGS.
- 22.02 SINK. SEE PLUMBING & FOOD SERVICE PLANS.
- 22.03 JANITOR'S FLOOR SINK. SEE PLUMBING & FOOD SERVICE PLANS.
- 22.04 HAND WASH SINK. SEE PLUMBING & FOOD SERVICE PLANS.
- 22.05 FLOOR DRAIN. SEE PLUMBING DRAWINGS.
- 22.06 WALL MOUNTED HOSE BIBB BOX. PROTECT NEARBY EXISTING WALL FROM DAMAGE. SEE PLUMBING PLAN.
- 22.07 CONDENSATE DRAIN LINE. PROTECT NEARBY EXISTING WALLS FROM DAMAGE. PATCH, REPAIR, & SEAL OPENINGS, AS REQUIRED. SEE PLUMBING PLANS.
- 22.08 FLOOR SINK. SEE PLUMBING PLANS.
- 26.02 ELECTRICAL PANEL. SEE ELECTRICAL PLANS.

KEY PLAN

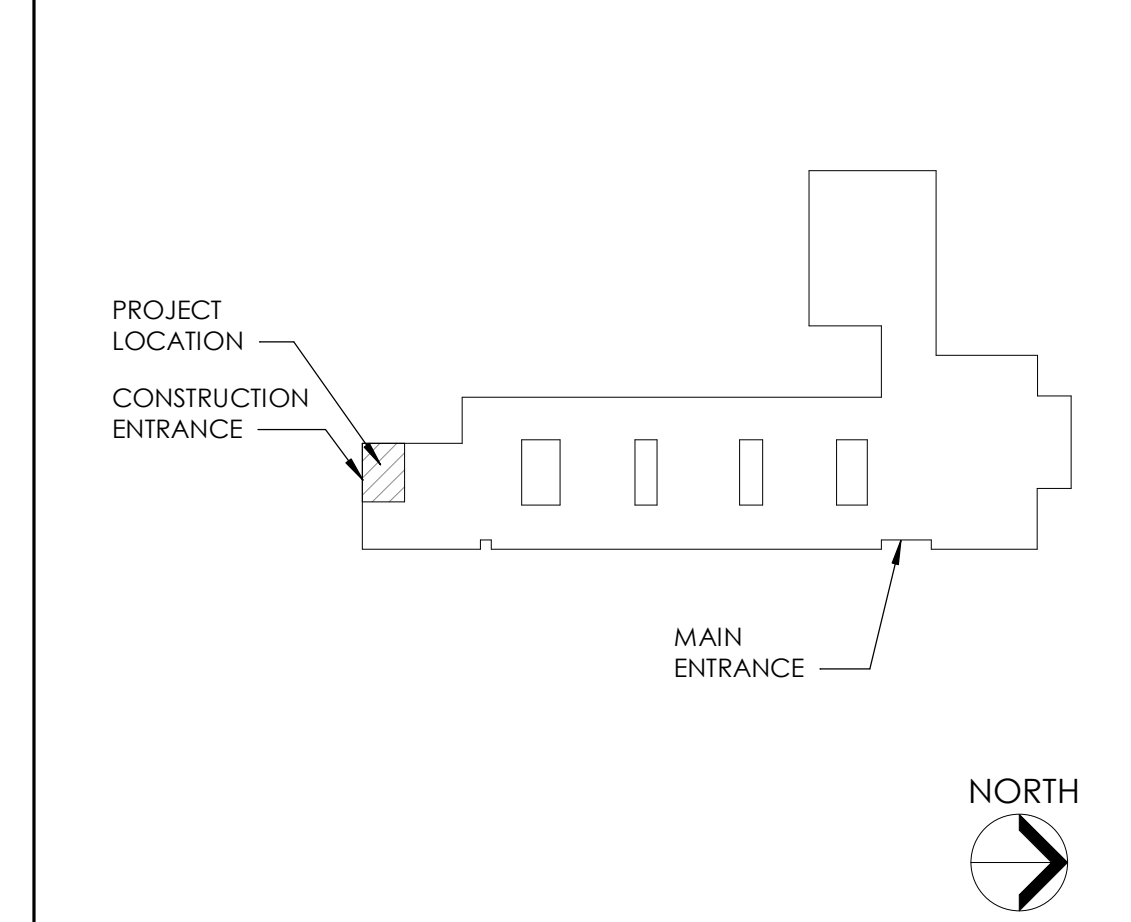

GENERAL NOTES

- A. SEE SHEET G003 AND G005 FOR SYMBOLS, GENERAL NOTES AND LEGEND.
- B. SEE SHEET A601 FOR DOOR & WINDOW SCHEDULES.
- C. SEE SHEET A602 FOR FINISH SCHEDULE AND GENERAL NOTES.

Ogden City School District
Highland Junior High School
Kitchen Remodel

325 Gramercy Ave
Ogden, Utah 84404

NJRA Project # 19709 00
Bid Set # Jan. 30, 2020
1 ADD. #1 2/20/20

Floor Plan

A113

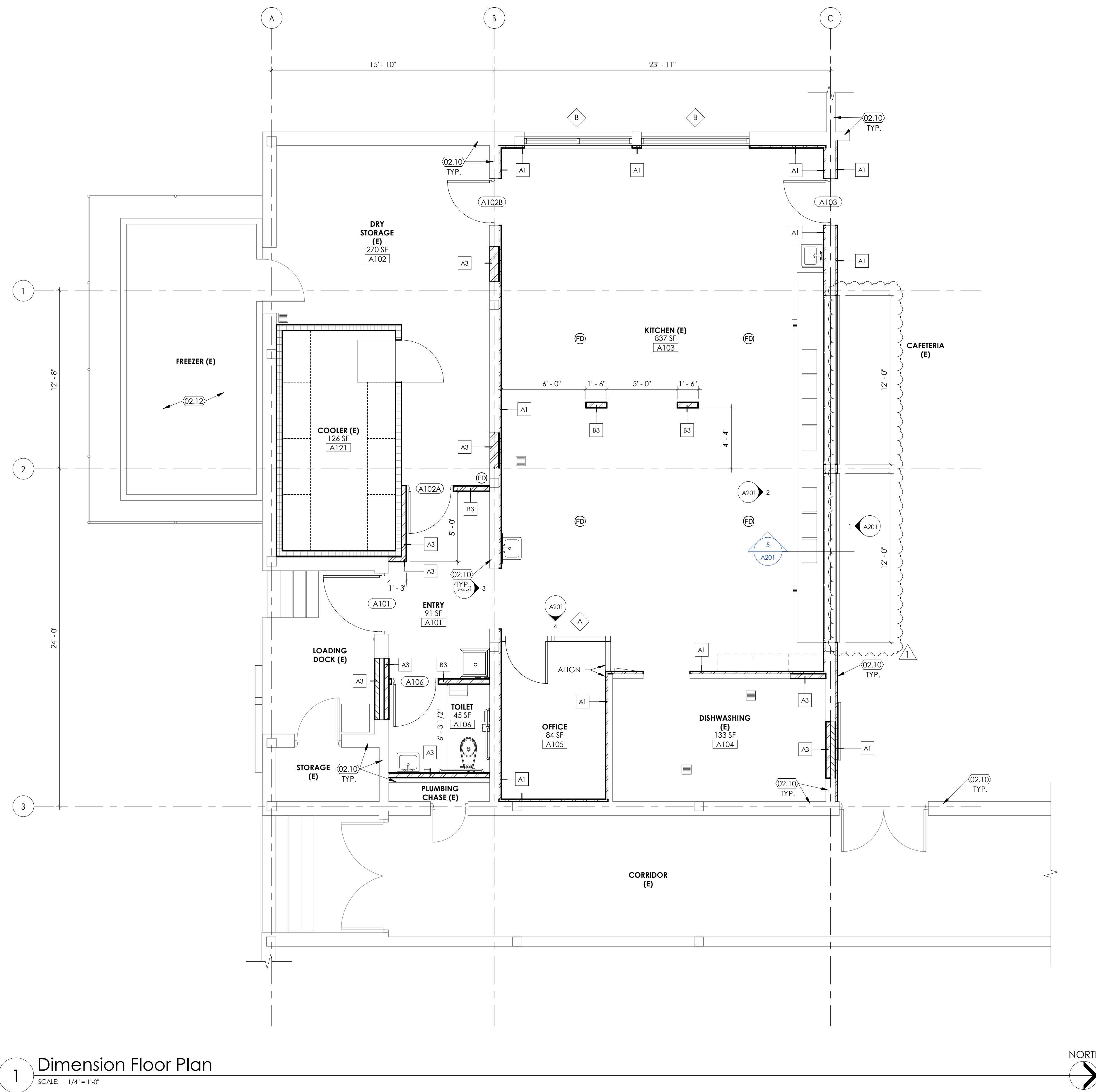

1 Dimension Floor Plan
SCALE: 1/4" = 1'-0"

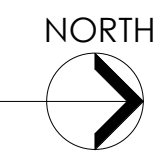

KEYED NOTES

- 02.10 EXISTING WALL TO REMAIN. PROTECT FROM DAMAGE. FIELD VERIFY.
- 02.12 EXISTING FREEZER, DOOR, & FLOOR TO REMAIN. PROTECT FROM DAMAGE. FIELD VERIFY.

KEY PLAN

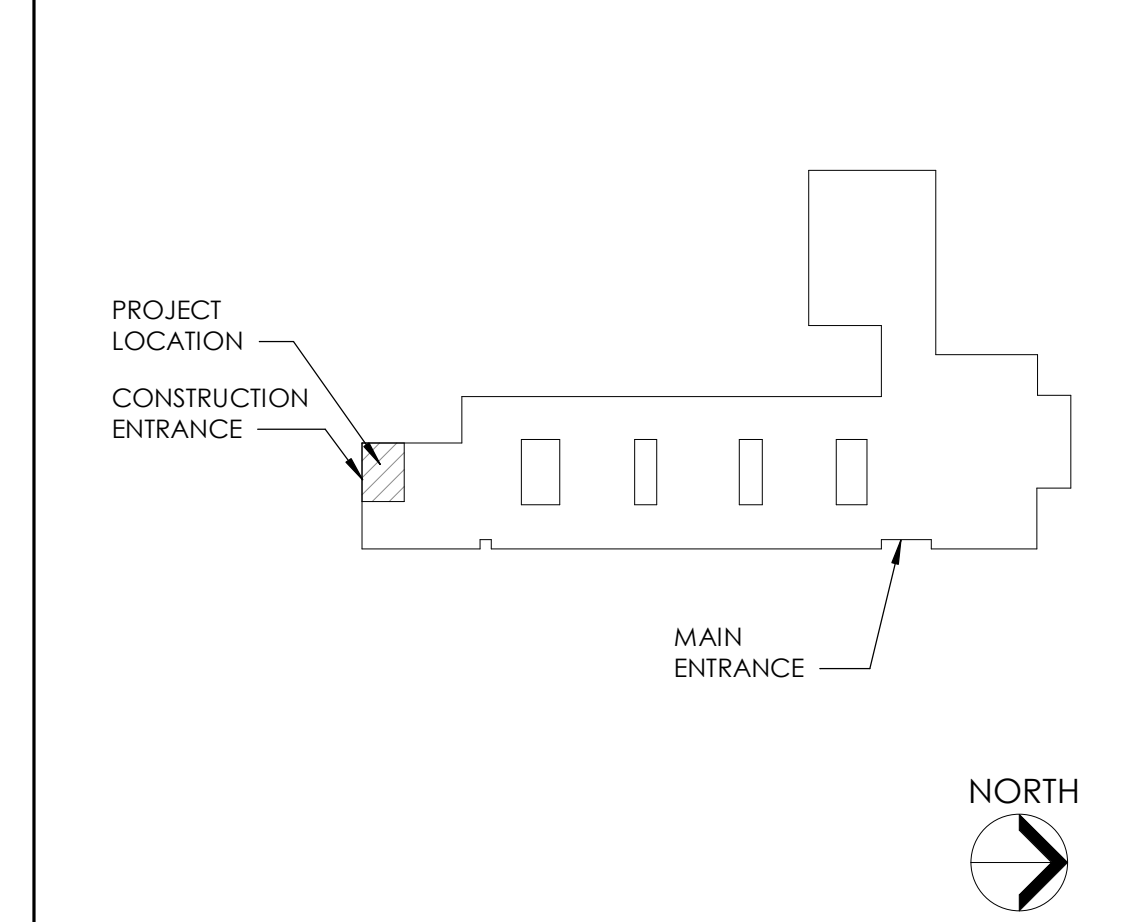

GENERAL NOTES

- A. SEE SHEET G003 AND G005 FOR SYMBOLS, GENERAL NOTES AND LEGEND.
- B. SEE SHEET A601 FOR DOOR & WINDOW SCHEDULES.
- C. SEE SHEET A602 FOR FINISH SCHEDULE AND GENERAL NOTES.



NJRA Architects, Inc.
5272 S. College Drive, Suite 104
Murray, Utah 84123
801.364.9259
www.njraarchitects.com

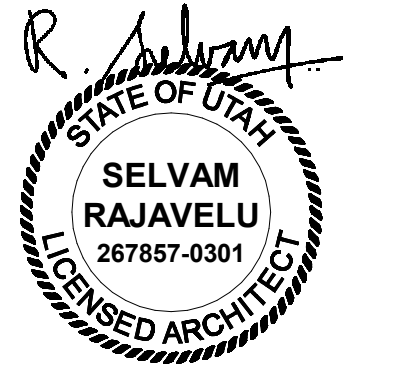

Ogden City School District
Highland Junior High School
Kitchen Remodel

325 Gramercy Ave
Ogden, Utah 84404

NJRA Project # 19709.00
Bid Set Jan. 30, 2020
1 ADD. #1 2/20/20

Dimension Floor Plan

A114

2/10/2020 10:06:58 AM

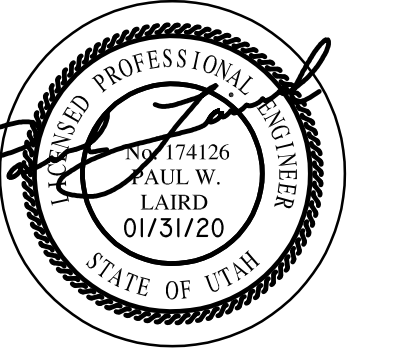

KEYED NOTES

1. HAND SINK, PIPE 1/2" CW AND 1/2" HW LINES UP THRU FLOOR AND CONNECT TO SINK FAUCET. PROVIDE ASSE 1070 TEMPERING VALVE UNDER SINK. MAKE ALL REQUIRED CONNECTIONS FOR A COMPLETE INSTALLATION. SEE DETAIL 1/P601.
2. PIPE 3/4" CW LINE FROM REDUCED PRESSURE BACKFLOW PREVENTERS TO STEAMERS, COMBI OVENS AND TEMPERING DRAINS. MAKE ALL REQUIRED CONNECTIONS FOR A COMPLETE INSTALLATION. SEE DETAIL 6/P601.
3. INSTALL REDUCED PRESSURE BACKFLOW PREVENTERS IN THIS LOCATION. EXTEND NEW 3/4" CW LINE TO STEAMERS, COMBI OVENS AND DRAIN KITS. SEE DETAIL 7/P601.
4. CONNECT TO EXISTING 1-1/2" 120 DEG F HW LINE AND 1" HWR LINE IN THIS LOCATION. PROVIDE DIELECTRIC UNIONS WITH GARLOK GASKETS AT EACH P.O.C. SEE DETAIL 6/P602.
5. CONNECT TO EXISTING 1-1/2" GAS LINE IN THIS LOCATION. PROVIDE NEW 1-1/2" GAS RATED BALL VALVE AT P.O.C. AND NEW 1-1/2" x 2" REDUCER.
6. PIPING TO RUN IN CRAWL SPACE BELOW FLOOR. COORDINATE LOCATION OF ALL NEW PIPING WITH EXISTING PIPING AND STRUCTURE. SUPPORT PIPING IN CRAWL SPACE WITH PIPE HANGERS FROM OVERHEAD STRUCTURE OR PROVIDE FLOOR SUPPORTS AND PIPE STANDS.
7. PREP SINK, PIPE 1/2" CW AND 1/2" 140 DEG F HW LINES UP THRU FLOOR AND CONNECT TO SINK FAUCET. MAKE ALL REQUIRED CONNECTIONS FOR A COMPLETE INSTALLATION.
8. PIPE 3/8" CW LINE UP THRU FLOOR TO ICE MAKER.
9. SERVICE SINK, PIPE 3/4" CW AND 3/4" 140 DEG F HW LINES UP THRU FLOOR AND CONNECT TO WALL MOUNTED SERVICE SINK FAUCET. PROVIDE AND INSTALL 5 FT LONG FLEXIBLE HOSE AND HOSE SUPPORT BRACKET.
10. EXTEND NEW 2" GAS, 1-1/4" 120 DEG F HW, 3/4" HWR AND 1-1/4" 140 DEG F HW LINES UP THRU FLOOR TO NEW WATER HEATER IN STORAGE CLOSET. CORE DRILL EXISTING FLOOR SLABS AS NEEDED. CAULK AND FILL OPENINGS AROUND THRU FLOOR PIPE PENETRATIONS.
11. INSTALL NEW HWR CIRCULATING PUMP IN THIS LOCATION. MOUNT PUMP HIGH CLOSE TO STRUCTURE. SEE DETAIL 2/P601.
12. INSTALL NEW GAS FIRED WATER HEATER IN THIS LOCATION. PIPE 1-1/4" 120 DEG F HW AND 1-1/4" 140 DEG F HW LINES TO WATER HEATER. MAKE ALL REQUIRED CONNECTIONS. SEE DETAIL 2/P601.
13. INSTALL NEW NON-FREEZE WALL MOUNTED HOSE BIBB IN THIS LOCATION. PIPE 3/4" CW LINE IN CRAWL SPACE TO HOSE BIBB. MODIFY EXISTING WALL OPENING TO ACCOMMODATE NEW HOSE BIBB BOX. GROUT SOLID AROUND HOSE BIBB UPON COMPLETION OF WORK.
14. PIPE NEW 1-1/4" CW AND 1/2" 140 DEG F HW UP THRU FLOOR TO PLUMBING CHASE. PROVIDE NEW BALL VALVES IN PLUMBING CHASE. EXTEND 1-1/4" CW LINE TO WATER CLOSET FLUSH VALVE AND 1/2" CW AND HW LINES TO NEW LAVATORY FIXTURE. MAKE ALL REQUIRED CONNECTIONS TO FIXTURES.
15. CONNECT TO EXISTING CW LINE IN THIS LOCATION. PROVIDE DIELECTRIC UNION WITH GARLOK GASKET AT P.O.C. SEE DETAIL 6/P602.
16. PIPE NEW 3/4" CW AND 3/4" 140 DEG F HW UP THRU FLOOR TO PRE-RINSE FAUCET AND DISPOSAL. MAKE ALL REQUIRED CONNECTIONS FOR A COMPLETE INSTALLATION.
17. PIPE NEW 3/4" 140 DEG F HW UP THRU FLOOR TO DISHWASHER. MAKE ALL REQUIRED CONNECTIONS FOR A COMPLETE INSTALLATION.
18. PIPE NEW 3/4" 140 DEG F HW UP THRU FLOOR TO ELECTRIC BOOSTER HEATER. EXTEND NEW 180 DEG F HW LINE FROM BOOSTER HEATER TO DISHWASHER. MAKE ALL REQUIRED CONNECTIONS FOR A COMPLETE INSTALLATION.
19. DISHWASH SINK, PIPE 1/2" CW AND 1/2" 140 DEG F HW LINES UP THRU FLOOR AND CONNECT TO SINK FAUCETS. MAKE ALL REQUIRED CONNECTIONS FOR A COMPLETE INSTALLATION.
20. CONNECT TO EXISTING 1" 120 DEG F HW LINE AND 1" HWR LINE IN THIS LOCATION. PROVIDE DIELECTRIC UNIONS WITH GARLOK GASKETS AT EACH P.O.C. SEE DETAIL 6/P602.
21. PIPE 1/2" CW LINE AND 1" GAS LINE UP TO MAU-1 ON ROOF. MAKE ALL REQUIRED GAS AND WATER LINE CONNECTIONS. SEE DETAIL 1/P602.
22. REFER TO KITCHEN EQUIPMENT DRAWINGS FOR ADDITIONAL PLUMBING REQUIREMENTS. PLUMBING CONTRACTOR IS RESPONSIBLE FOR MAKING ALL WATER, GAS, DRAIN AND VENT CONNECTIONS TO ALL KITCHEN EQUIPMENT INDICATED.
23. INSTALL ISOLATION SERVICE BALL VALVES IN VERTICAL PIPING (TYPICAL).
24. HOSE REEL, PIPE 3/4" CW AND 3/4" 140 DEG F HW LINES UP THRU FLOOR AND CONNECT TO HOSE REEL. PROVIDE SVB VACUUM BREAKER 12" ABOVE P.O.C. MAKE ALL REQUIRED CONNECTIONS FOR A COMPLETE INSTALLATION. SEE DETAIL 5/P602.
25. PIPE 1" GAS UP THRU FLOOR TO ROOF. CONNECT TO MAU-1. SEE DETAIL 1/P602.
26. PIPING TO RUN HIGH ABOVE CEILING.
27. INSTALL NEW PLUMBING FIXTURES AS INDICATED.
28. CHEMICAL FILL STATION. SEE DETAIL 7/P602.
29. INSTALL MAU-1 FILL AND DRAIN PANEL IN THIS LOCATION. SEE DETAIL 8/P602.

GENERAL NOTES

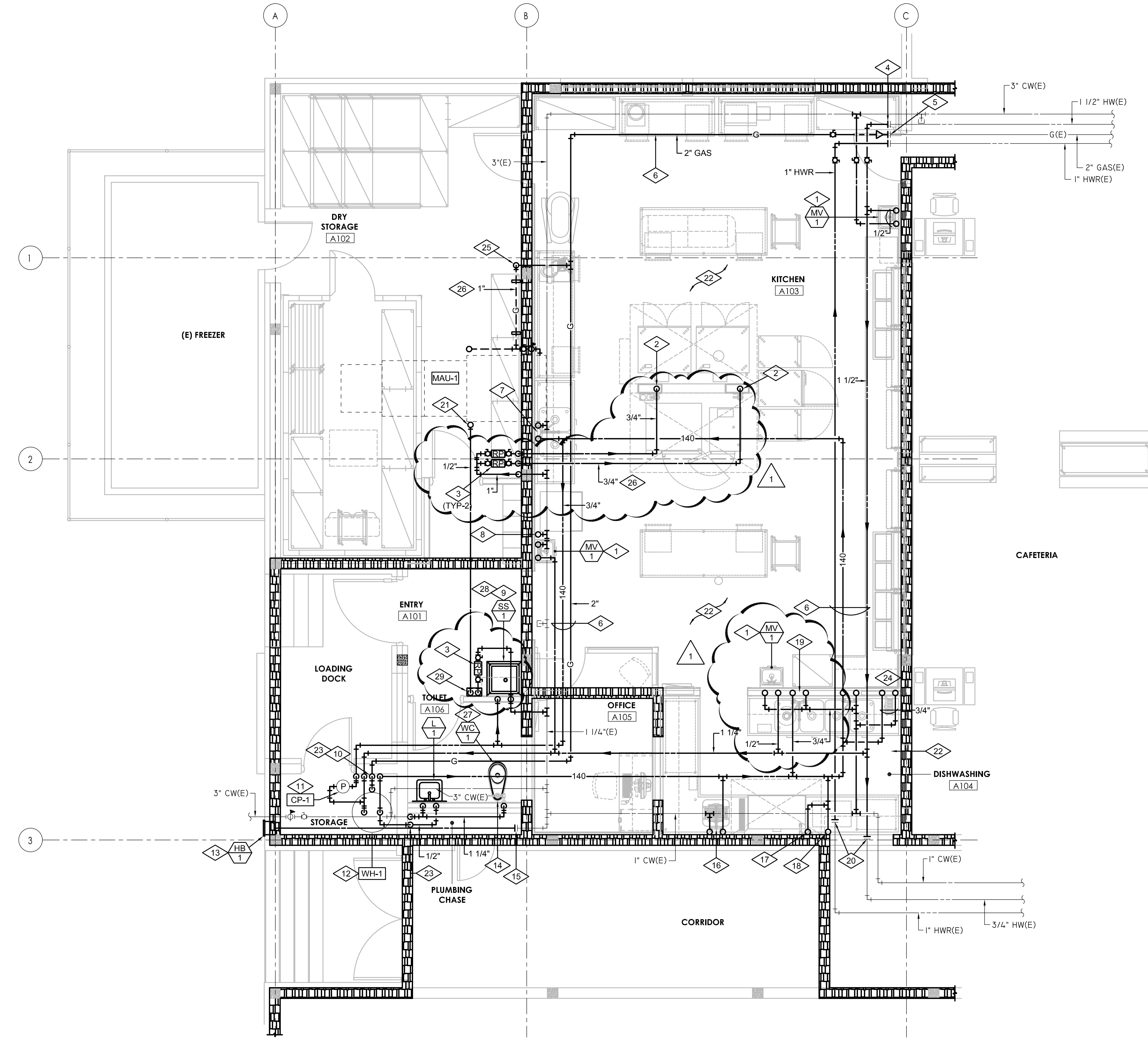

1 Plumbing Plan Water & Gas
SCALE: 1/4" = 1'-0"

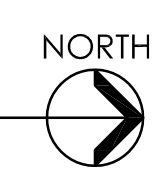

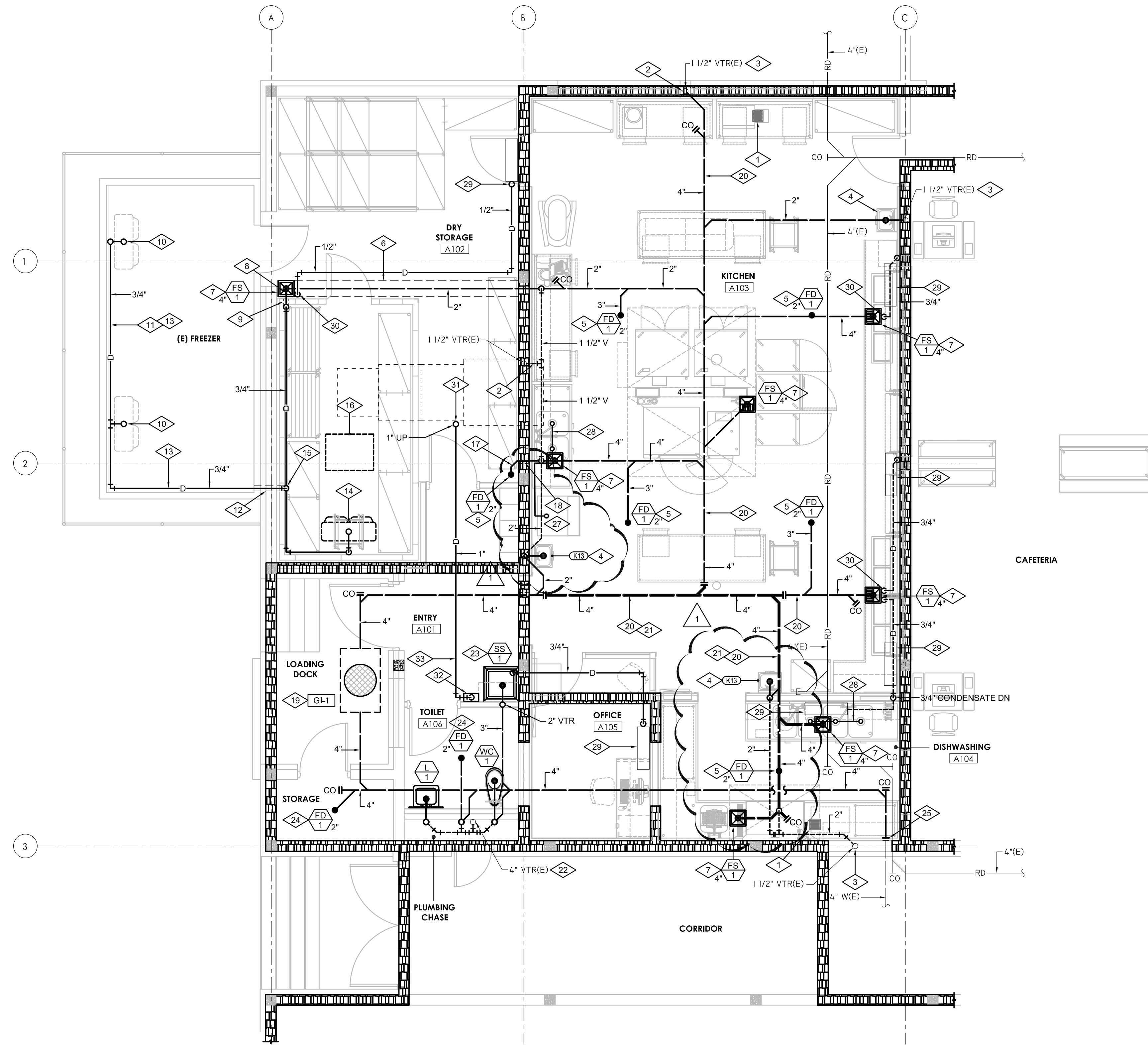

1 Plumbing Plan Waste & Vent
SCALE: 1/4" = 1'-0"

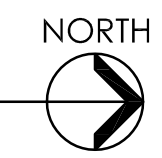

KEYED NOTES

1. WHERE EXISTING FLOOR SINKS OR FLOOR DRAINS WERE REMOVED AND NOT RE-USED AS PART OF THE NEW WORK, PROVIDE FLOOR PATCHING AND REPAIR OF THE FLOOR OPENING TO MATCH EXISTING.
2. PIPE NEW 1-1/2" VENT LINE(S) FROM NEW ABS WASTE PIPING AND CONNECT TO EXISTING 1-1/2" VTR. PROVIDE ABS / C.I. FERNOCO COUPLING AT P.O.C.
3. VERIFY LOCATION AND FUNCTION OF EXISTING 1-1/2" VTR.
4. INSTALL NEW HAND SINK IN THIS LOCATION. PIPE 1-1/2" DRAIN LINE ON IN WALL. MAKE CONNECTIONS TO EXISTING 1-1/2" VTR IF AVAILABLE.
5. INSTALL NEW FLOOR DRAIN IN THIS LOCATION. CORE DRILL EXISTING FLOOR AS NEEDED. PATCH AND REPAIR THE FLOOR OPENING TO MATCH EXISTING.
6. SAWCUT THE EXISTING SLAB AND EXCAVATE AS NEEDED TO INSTALL NEW 2" DRAIN LINE FROM FLOOR SINK. PATCH AND REPAIR THE FLOOR TO MATCH EXISTING UPON COMPLETION OF WORK.
7. INSTALL NEW FLOOR SINK IN THIS LOCATION. CORE DRILL EXISTING FLOOR AS NEEDED. PATCH AND REPAIR THE FLOOR OPENING TO MATCH EXISTING.
8. PIPE 3/4" COPPER CONDENSATE DRAIN LINE FROM FREEZER/COOLER EVAPORATORS TO FLOOR SINK. TERMINATE DRAIN LINE 1" ABOVE THE FLOOR RIM.
9. DRILL COOLER INSULATION PANEL AS NEEDED TO INSTALL NEW 3/4" COPPER CONDENSATE DRAIN LINE. CAULK OPENING AROUND PIPE AND PROVIDE CHROME PLATED PIPE ESCUTCHEONS ON BOTH SIDES OF PANEL.
10. REPIPE THE CONDENSATE DRAIN LINES FROM THE EXISTING EVAPORATORS IN THE EXISTING FREEZER. RAISE AND REROUTE DRAIN PIPING AS NEEDED TO CONNECT TO NEW COOLER CONDENSATE DRAIN LINE INDICATED.
11. SLOPE CONDENSATE DRAIN LINE AT 1/4" SLOPE PER FOOT.
12. DRILL FREEZER/COOLER INSULATION PANELS AS NEEDED TO INSTALL NEW 3/4" COPPER CONDENSATE DRAIN LINE. CAULK OPENING AROUND PIPE AND PROVIDE CHROME PLATED PIPE ESCUTCHEONS ON BOTH SIDES OF PANEL.
13. SPIRAL HEAT TRACE, INSULATE AND ALUMINUM JACKET ALL CONDENSATE DRAIN LINES IN FREEZER.
14. INSTALL NEW 3/4" COPPER CONDENSATE DRAIN LINE FROM COOLER EVAPORATOR. COORDINATE LOCATION WITH FREEZER CONDENSATE DRAIN PIPING.
15. CONNECT 3/4" COPPER CONDENSATE FREEZER DRAIN LINE TO NEW CONDENSATE DRAIN LINE SERVING COOLER IN THIS LOCATION.
16. NEW COOLER CONDENSING UNIT ON ROOF PROVIDED AND INSTALLED BY OTHERS
17. SAWCUT THE EXISTING SLAB AND EXCAVATE AS NEEDED TO INSTALL NEW 2" FLOOR DRAIN IN THIS LOCATION. PATCH AND REPAIR THE FLOOR TO MATCH EXISTING UPON COMPLETION OF WORK.
18. CORE DRILL EXISTING FOUNDATION WALL IN CRAWL SPACE AS NEEDED TO INSTALL WASTE AND DRAIN PIPING. GROUT OPENING AROUND PIPE OR PROVIDE MECHANICAL SLEEVE SEAL.
19. INSTALL NEW POLYPROPYLENE GREASE INTERCEPTOR IN THIS LOCATION. G.C. TO PROVIDE 36" x 48" FLOOR OPENING AND NEW HINGED ACCESS HATCH IN DOCK AREA FOR INSTALLATION OF THE GREASE INTERCEPTOR. LOCATE GREASE INTERCEPTOR TO PROVIDE FOR SERVICE AND OPERATIONAL CLEARANCES. PROVIDE NEW CONCRETE SERVICE PAD AND ELEVATE THE GREASE INTERCEPTOR AS NEEDED. SEE INSTALLATION DETAIL 6P961.
20. RUN NEW ABS WASTE AND DRAIN PIPING HIGH IN CRAWL SPACE. COORDINATE LOCATION OF PIPING WITH EXISTING ROOF DRAIN, HVAC PIPING AND WATER SUPPLY PIPING. SLOPE PIPING AT 1.25%
21. ALL NEW WASTE AND DRAIN PIPING SERVING THE DISHWASHER AREA SHALL BE CAST IRON. EXTEND CAST IRON PIPING A MINIMUM OF 25 FEET FROM THE DISHWASHER BEFORE TRANSITIONING TO ABS PIPE.
22. VERIFY LOCATION AND FUNCTION OF EXISTING 4" VTR. CONNECT NEW PLUMBING VENTS FROM RESTROOM FIXTURES AND MAIN 4" ABS WASTE LINE IN CRAWL SPACE TO EXISTING 4" VTR.
23. INSTALL NEW SERVICE SINK IN THIS LOCATION. PIPE 3" ABS DRAIN LINE AND CONNECT TO NEW 4" ABS DRAIN LINE AS INDICATED.
24. INSTALL NEW RESTROOM AND STORAGE CLOSET FLOOR DRAINS IN SAME LOCATION AS EXISTING. MAKE ALL REQUIRED PIPING CONNECTIONS TO NEW DRAIN LINES.
25. CONNECT NEW 4" ABS WASTE PIPE TO EXISTING 4" C.I. PIPE IN THIS LOCATION.
26. PIPE INDIRECT DRAIN LINES FROM PREP SINK IN SCH 40 WHITE PVC PIPE TO FLOOR SINK. TERMINATE DRAIN LINES ABOVE FLOOR RIM OF FLOOR SINK. SEE DETAIL 2P962.
27. PIPE CONDENSATE DRAIN LINE FROM ICE MAKER TO FLOOR SINK.
28. PIPE INDIRECT WASTE FROM SINK TO FLOOR SINK.
29. PIPE 3/4" PUMPED CONDENSATE DRAIN LINE FROM HEAT PUMP UNIT TO FLOOR SINK. RUN PIPE ABOVE CEILING.
30. TERMINATE CONDENSATE DRAIN LINE ABOVE FLOOR SINK.
31. PIPE 1" DRAIN LINE FROM MAU-1 TO FILL AND DRAIN PANEL.
32. MAU-1 FILL AND DRAIN PANEL. SEE DETAIL 6P962.
33. PIPING TO RUN ABOVE CEILING.

GENERAL NOTES



NJRA Architects, Inc.
5272 S. College Drive, Suite 104
Murray, Utah 84123
801.364.9259
www.njraarchitects.com

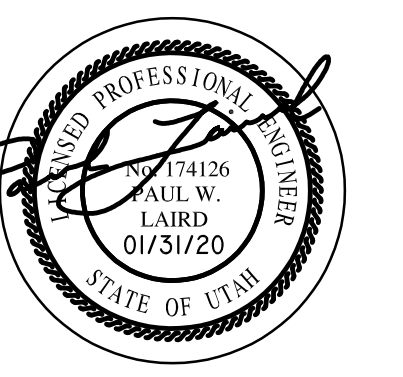

14 E. 2700 S. Salt Lake City, UT. 84115 PH: (801) 486-4646

Ogden City School District
 Highland Junior High School
 Kitchen Remodel

325 Gramercy Ave
 Ogden, Utah 84404

NJRA Project # 19709-00
 Bid Set Jan. 30, 2020
 Add #1 Feb. 17, 2020

Plumbing
Plan
Waste &
Vent

P112

10/3/2019 11:12:07 AM

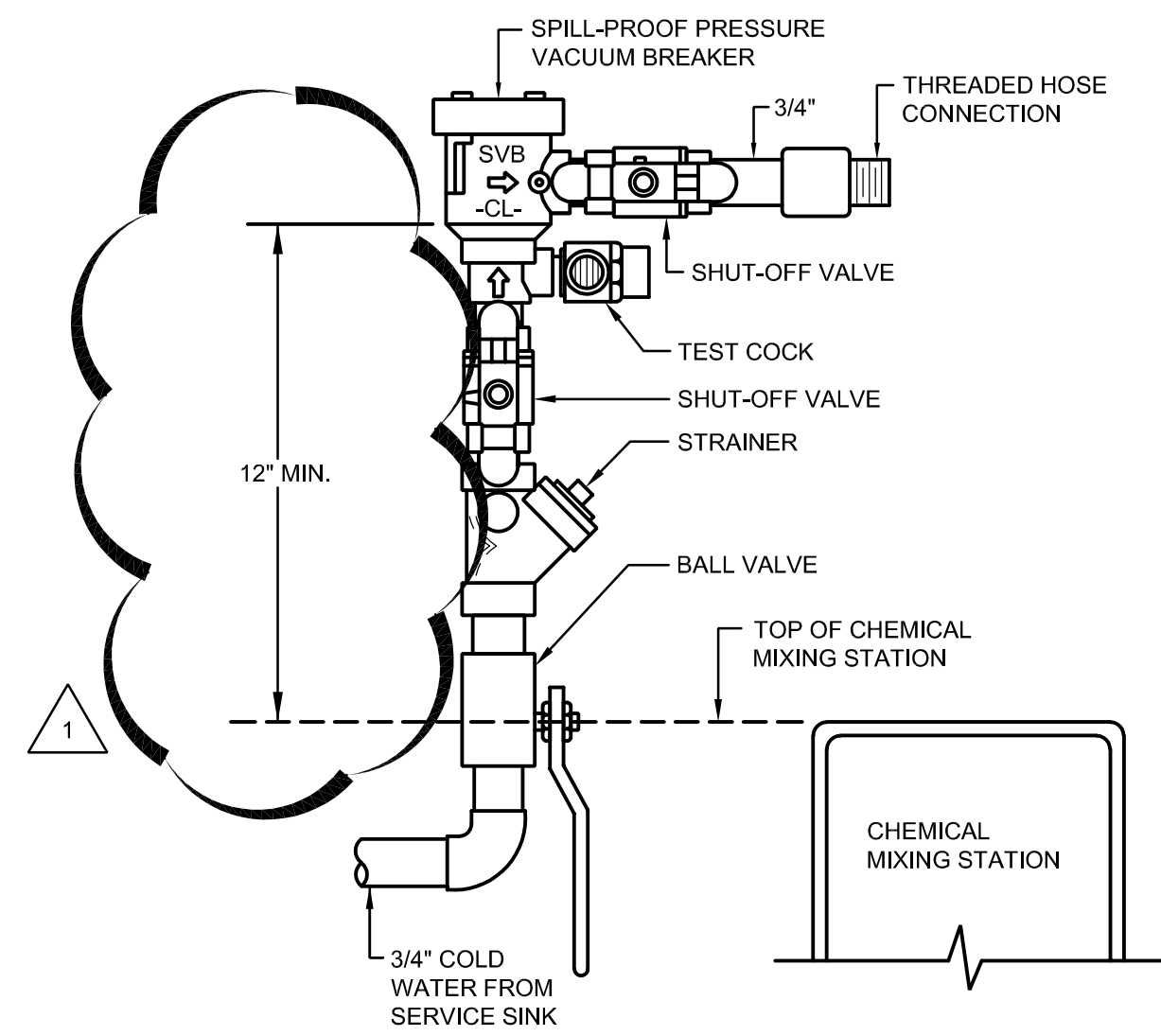

SPILL-PROOF VACUUM BREAKER AT SS-1 DETAIL
NOT TO SCALE

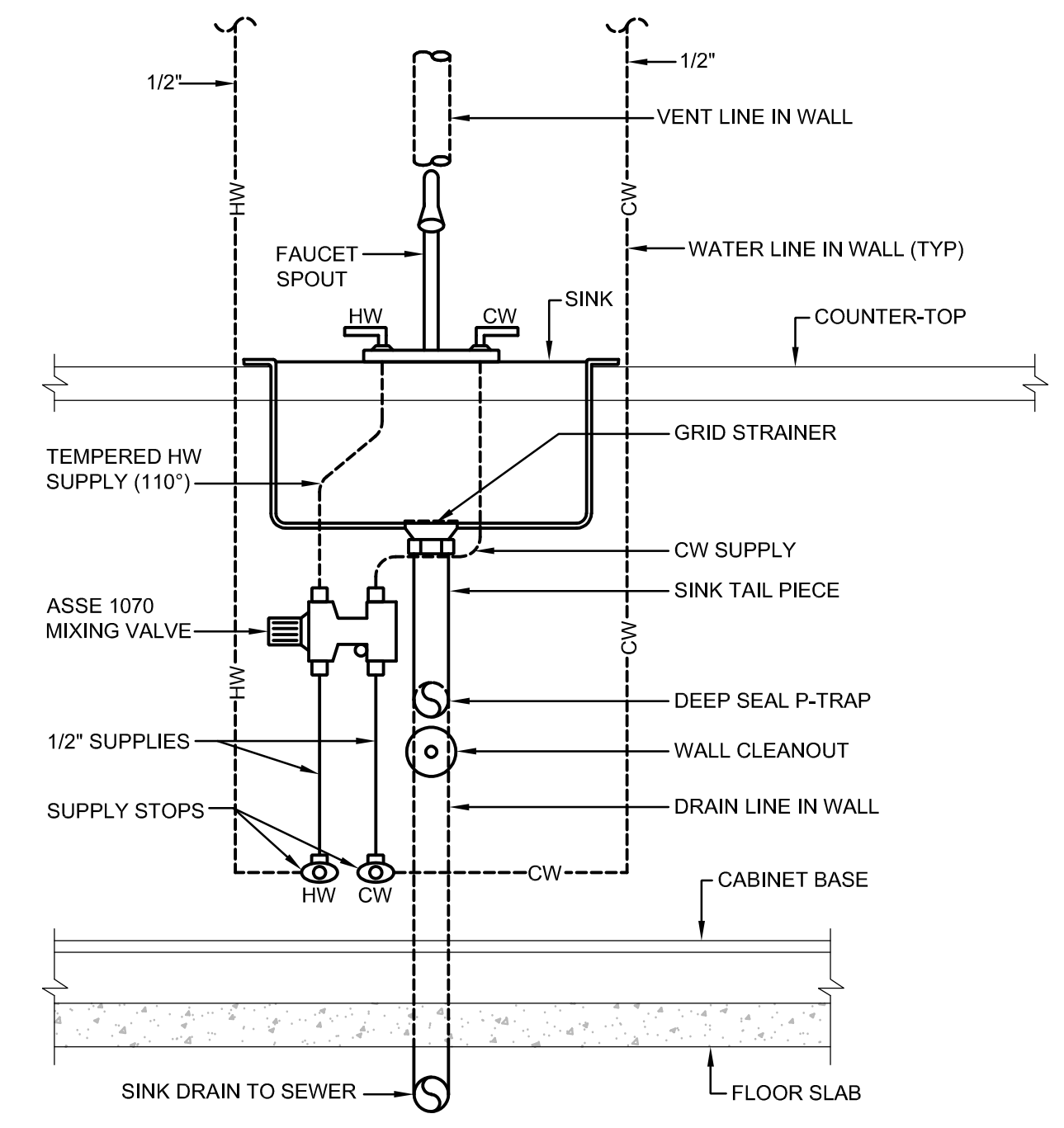

SINK INSTALLATION DETAIL
NOT TO SCALE

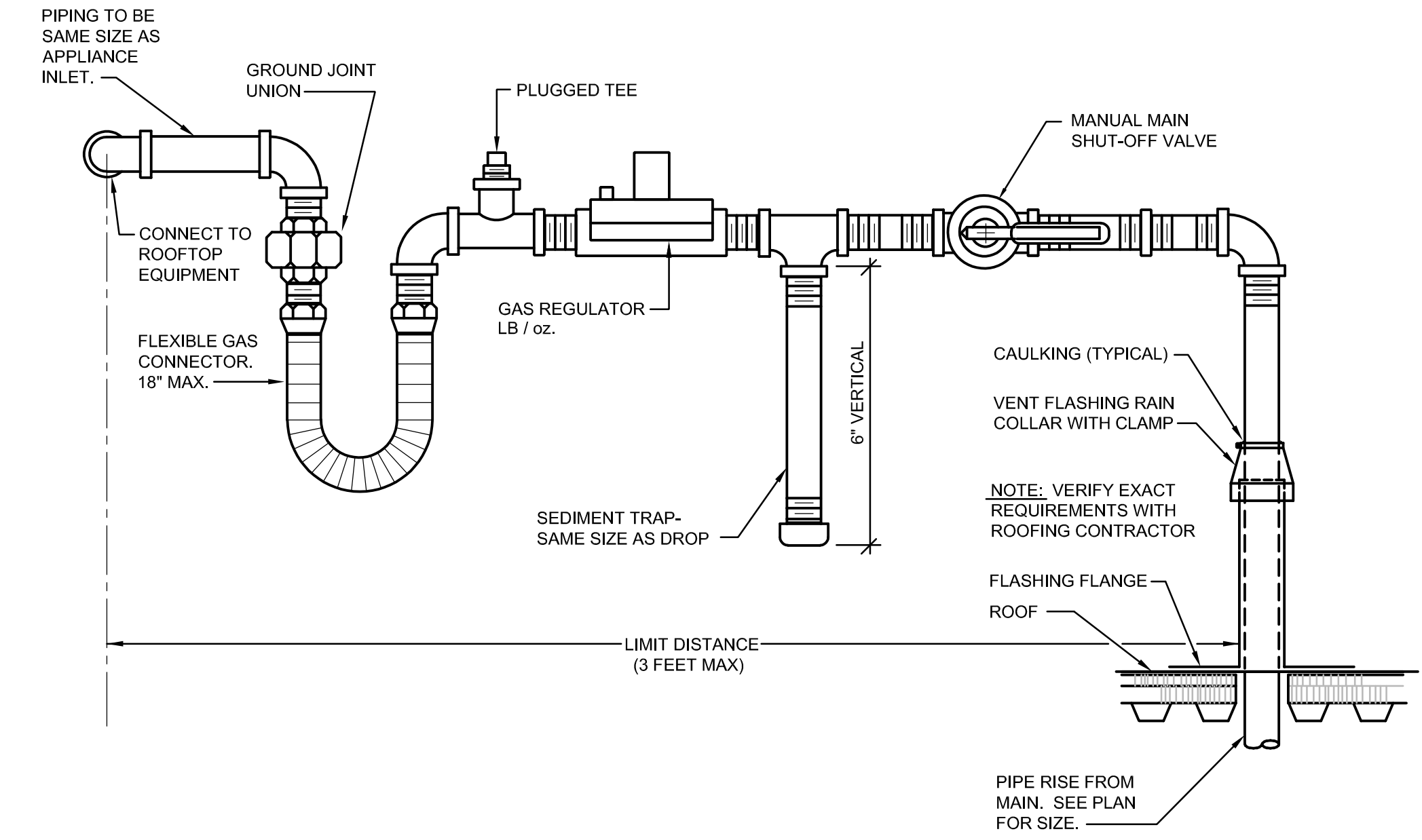

ROOFTOP GAS LINE CONNECTION DETAIL
NOT TO SCALE

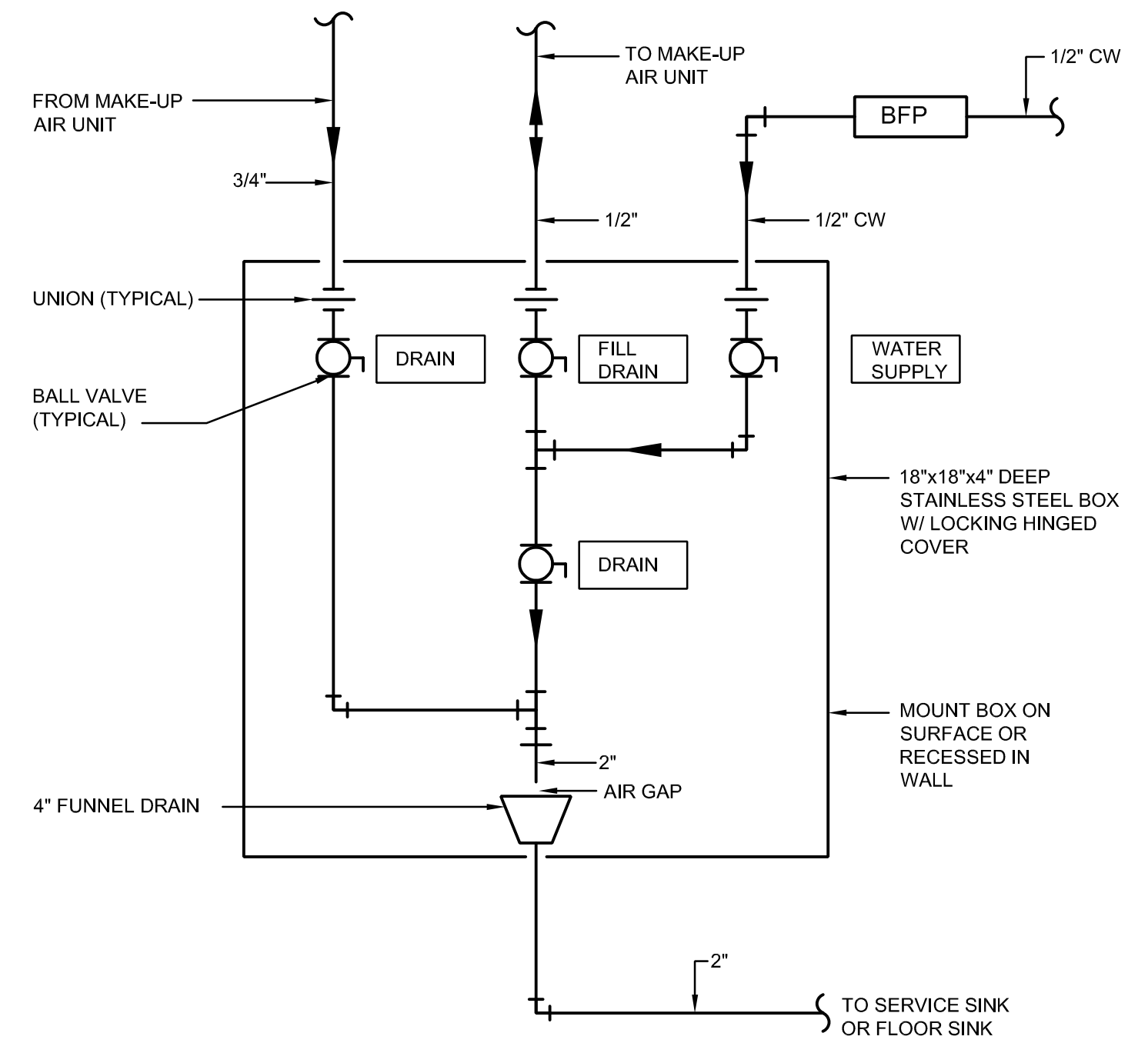

DRAIN & FILL PANEL DETAIL
NOT TO SCALE

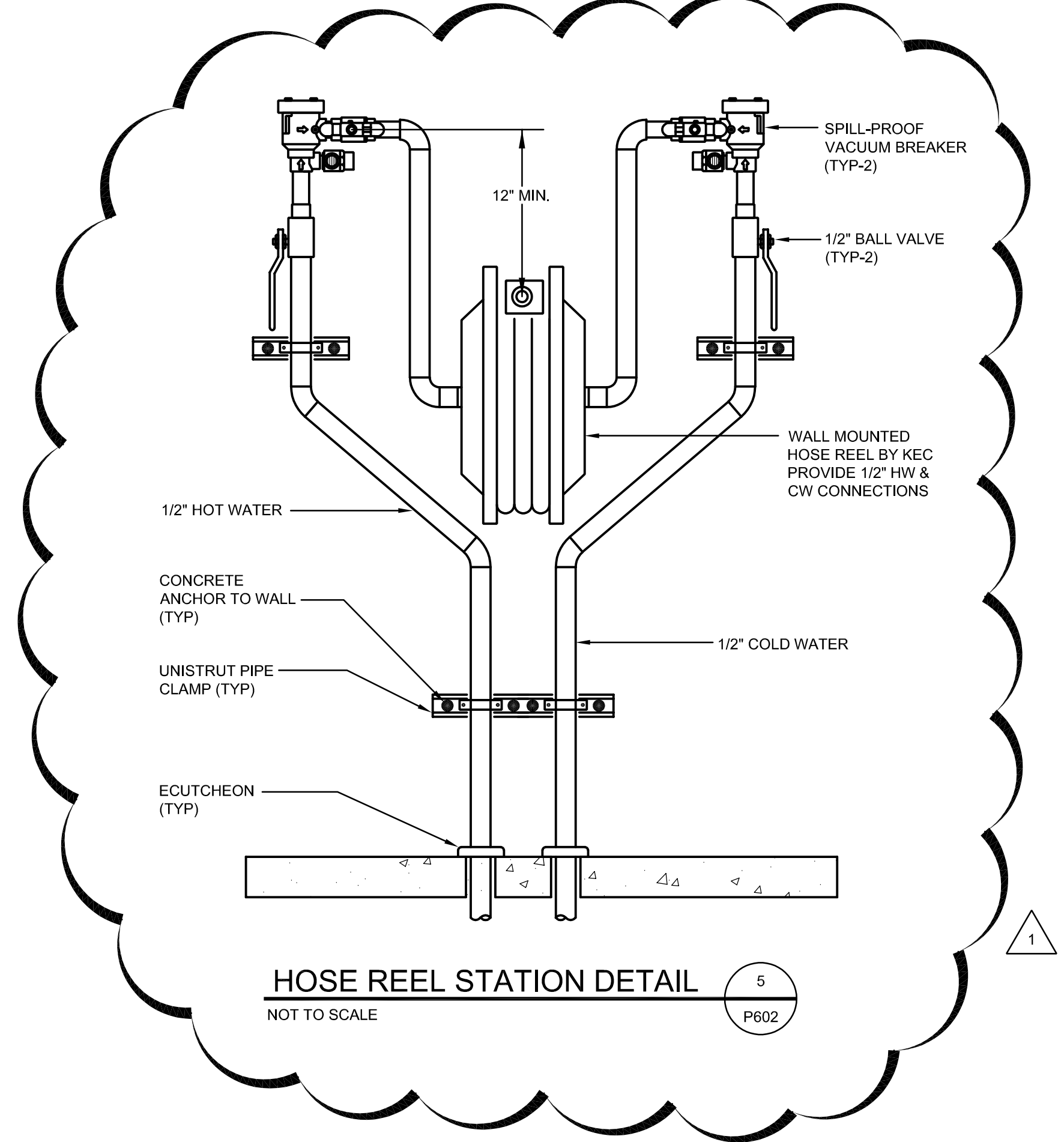

HOSE REEL STATION DETAIL
NOT TO SCALE

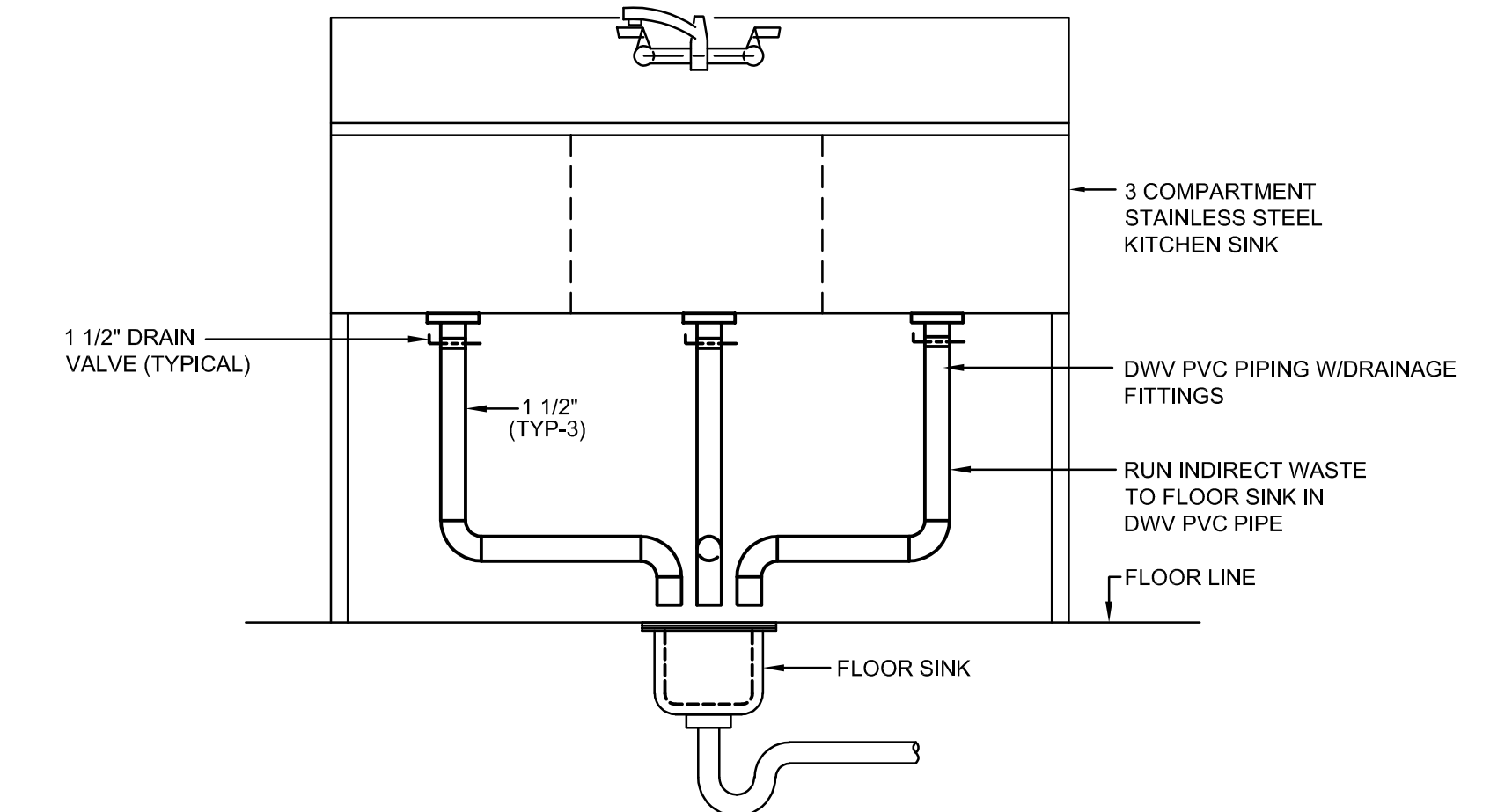

INDIRECT SINK WASTE DETAIL
NOT TO SCALE

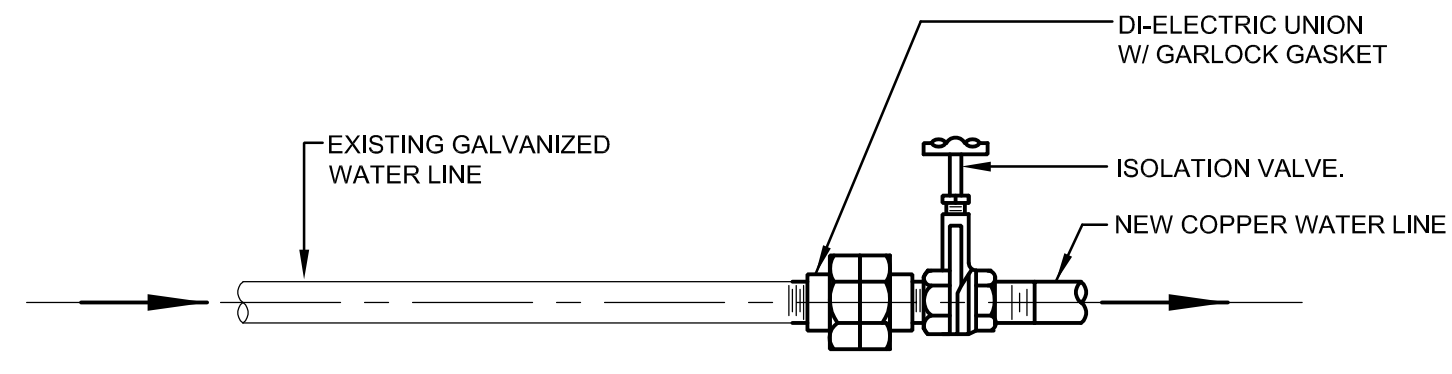

DI-ELECTRIC UNION CONNECTION DETAIL
NOT TO SCALE

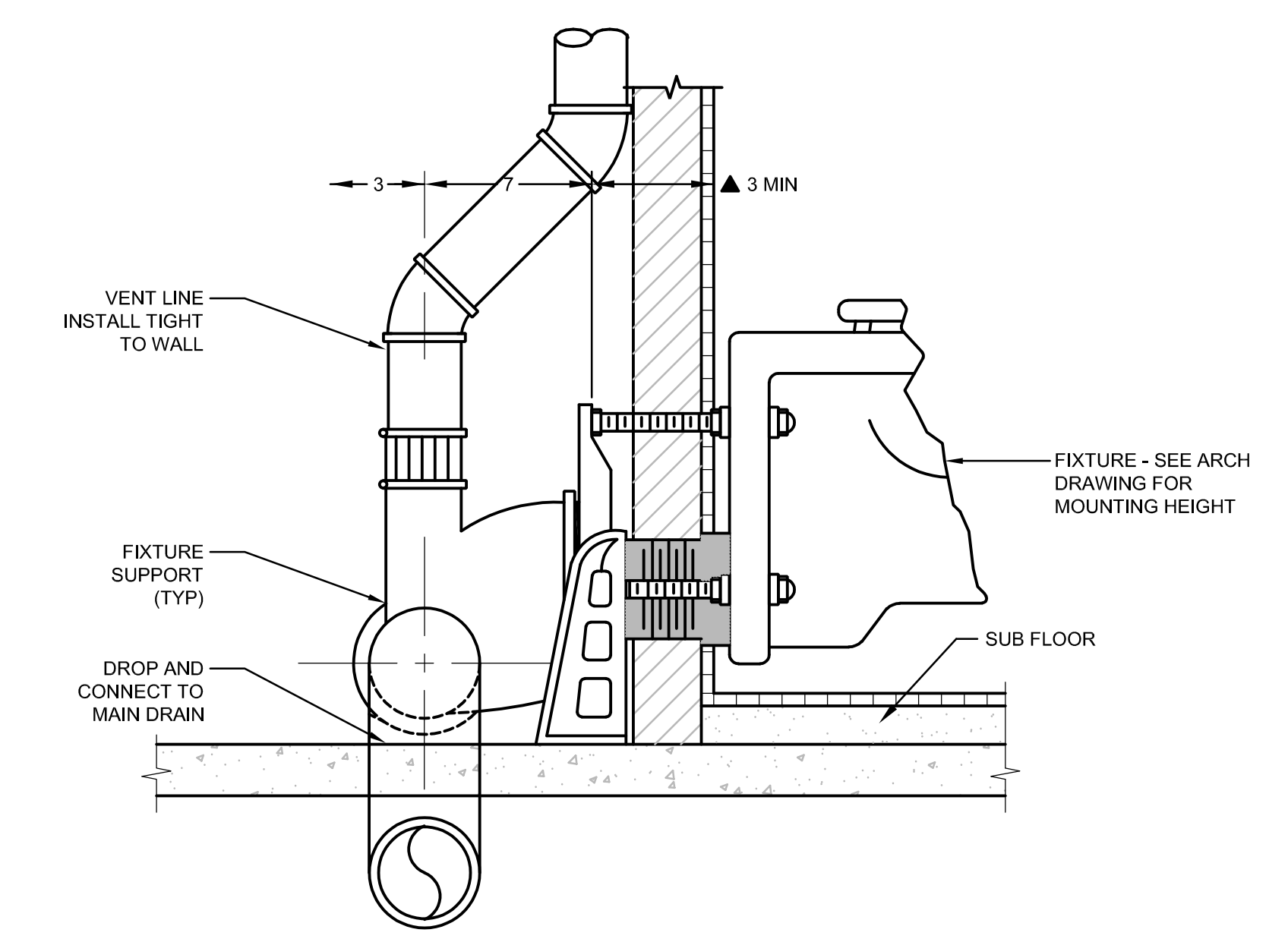

WATER CLOSET SUPPORT DETAIL
NOT TO SCALE

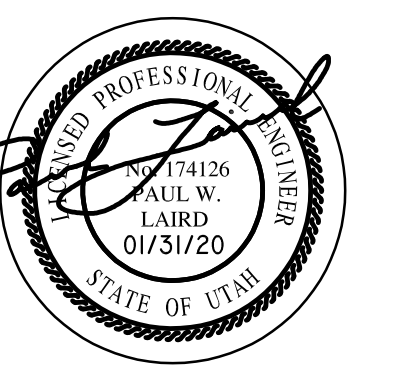

PRELIMINARY
NOT FOR
CONSTRUCTION



Jedziewski Designs
1537 Yale Avenue
Salt Lake City, Utah 84105
(801) 582-9747 Office
(801) 403-9073 Cell
JedziewskiDesigns.com

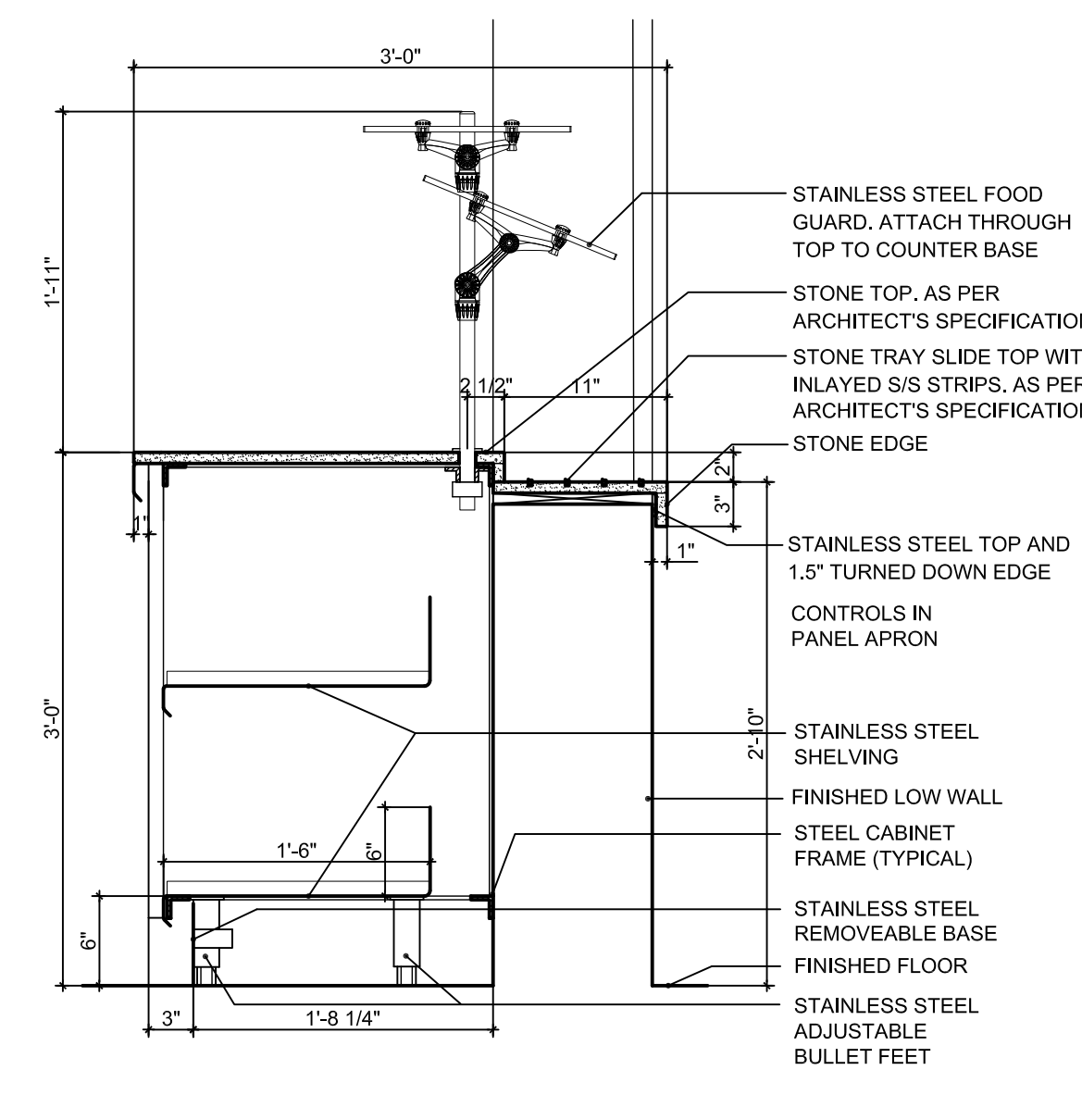

SERVING COUNTER SECTION DETAIL
SCALE: 1" = 1'-0"
FS101

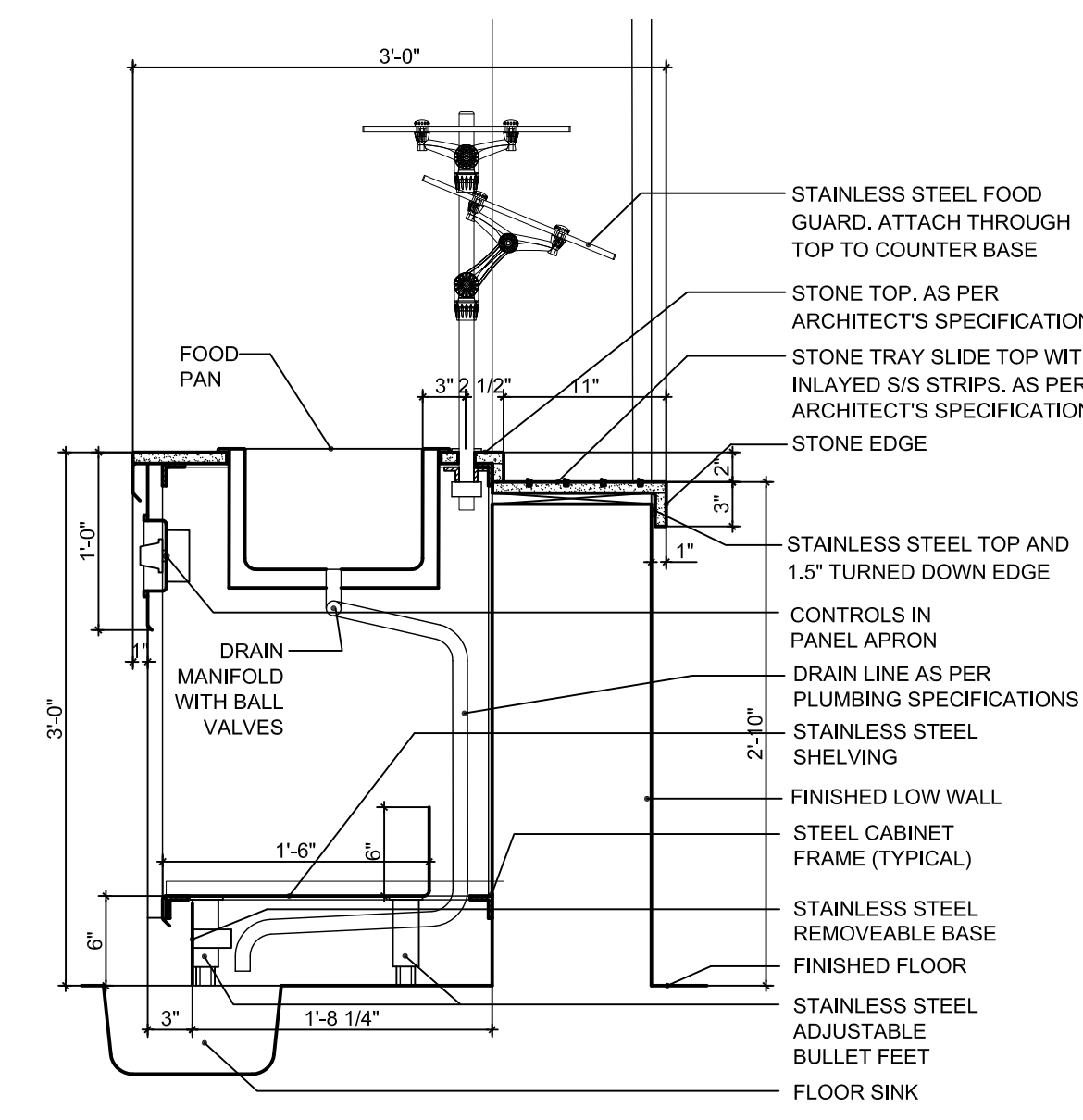

SERVING COUNTER, HOT WELLS SECTION DETAIL
SCALE: 1" = 1'-0"
FS101

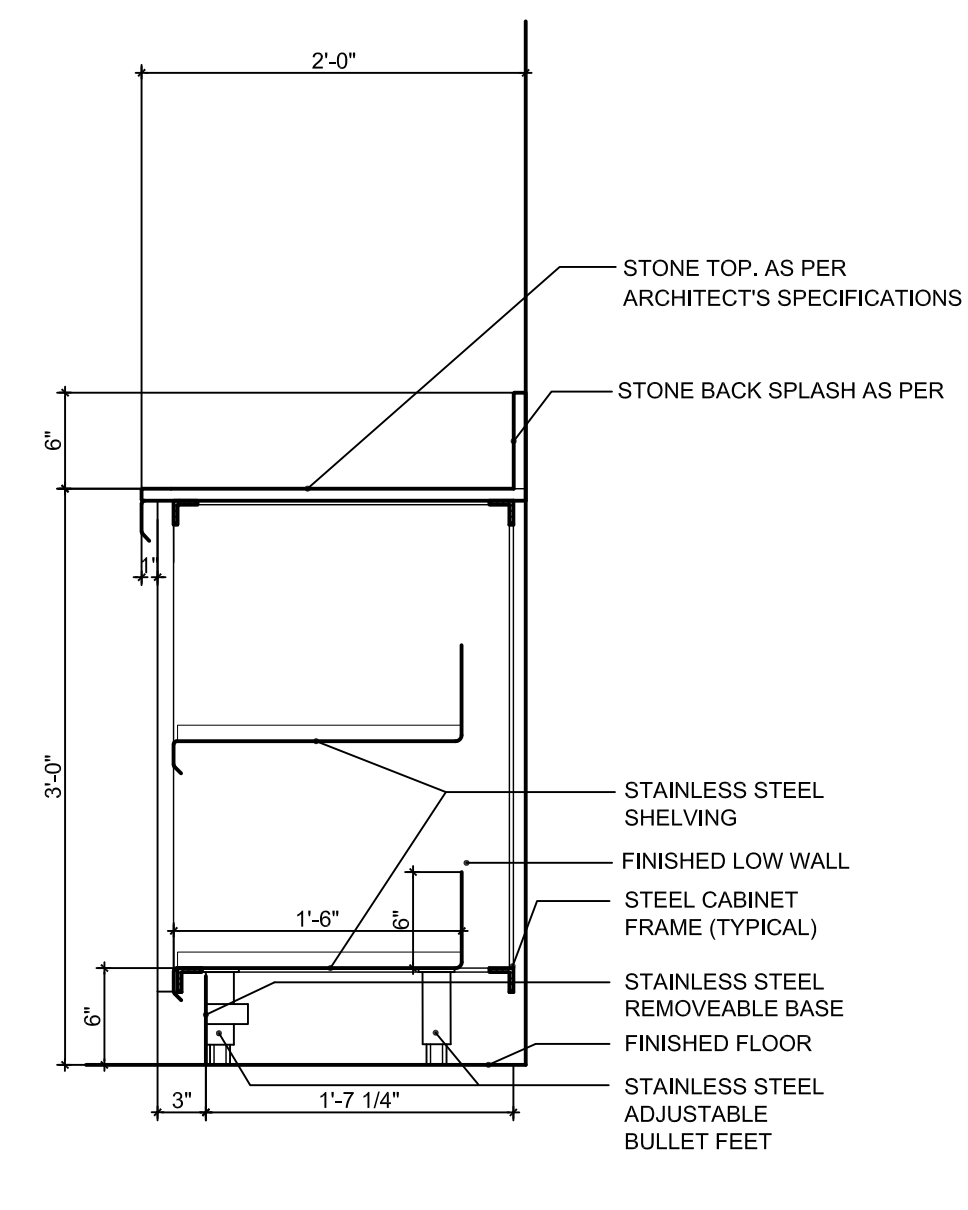

SERVING COUNTER SECTION DETAIL
SCALE: 1" = 1'-0"
FS101

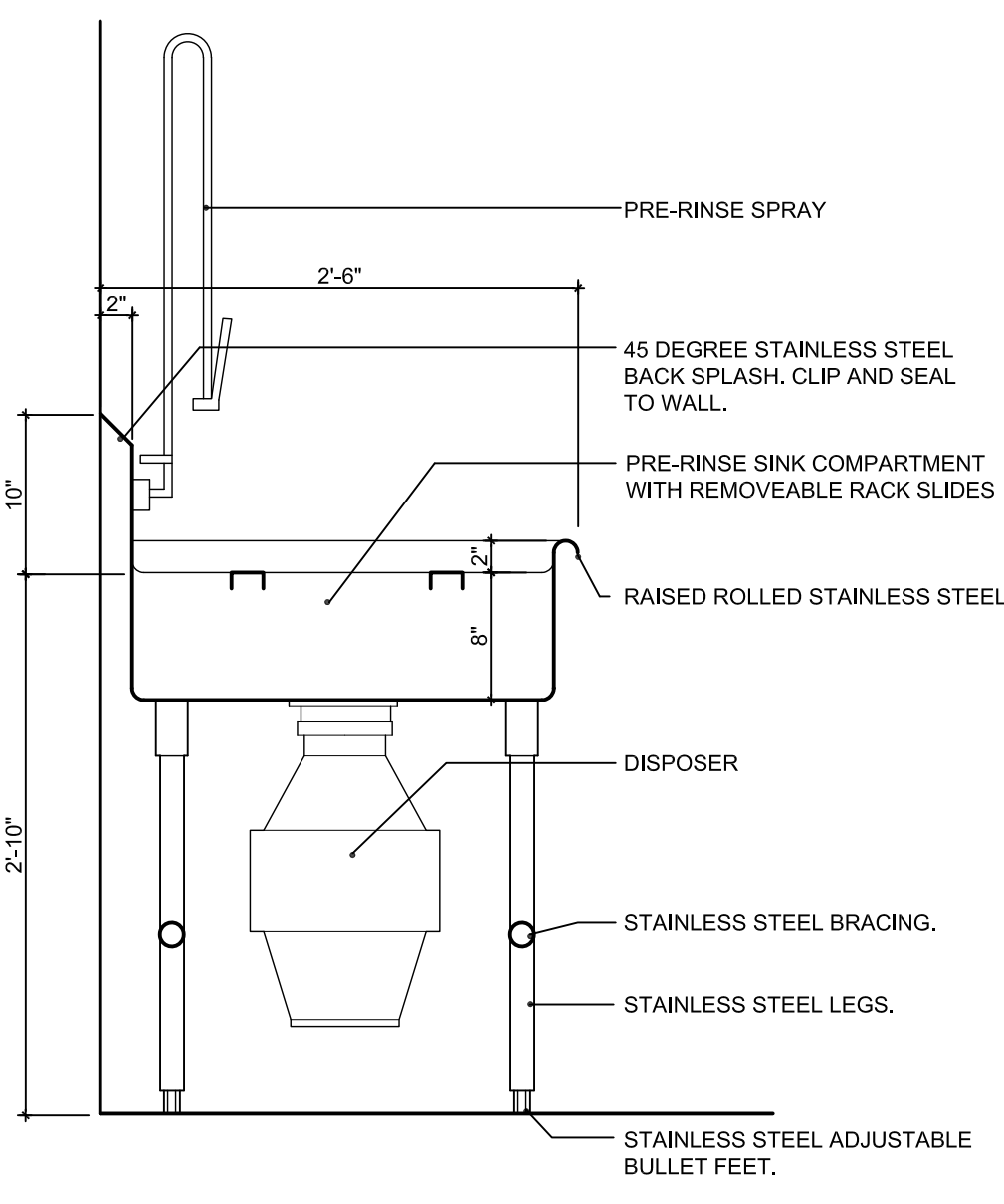

DISH TABLE, PRE-RINSE SINK SECTION DETAIL
SCALE: 1" = 1'-0"
FS101

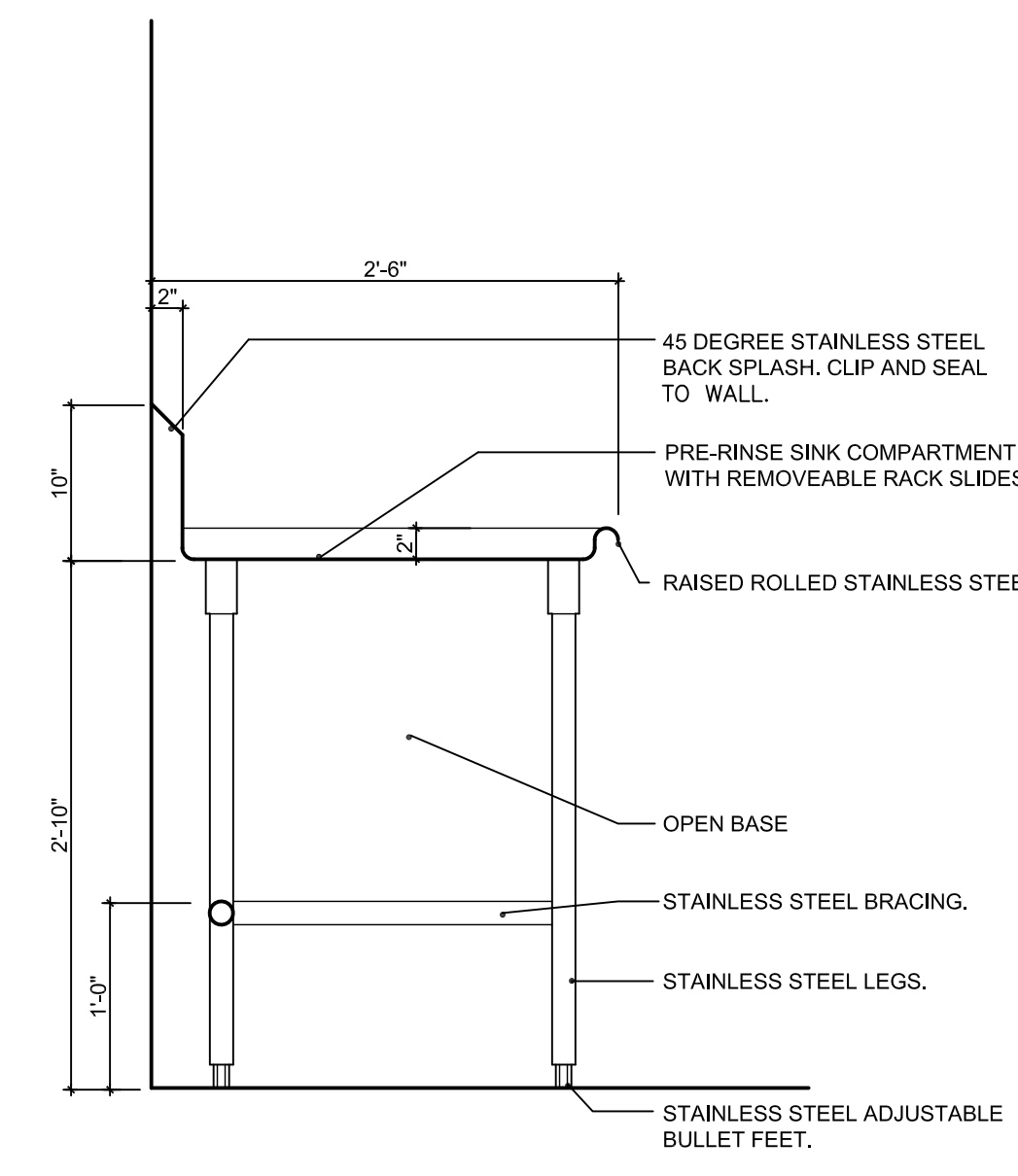

DISH TABLE, OPEN BASE SECTION DETAIL
SCALE: 1" = 1'-0"
FS101

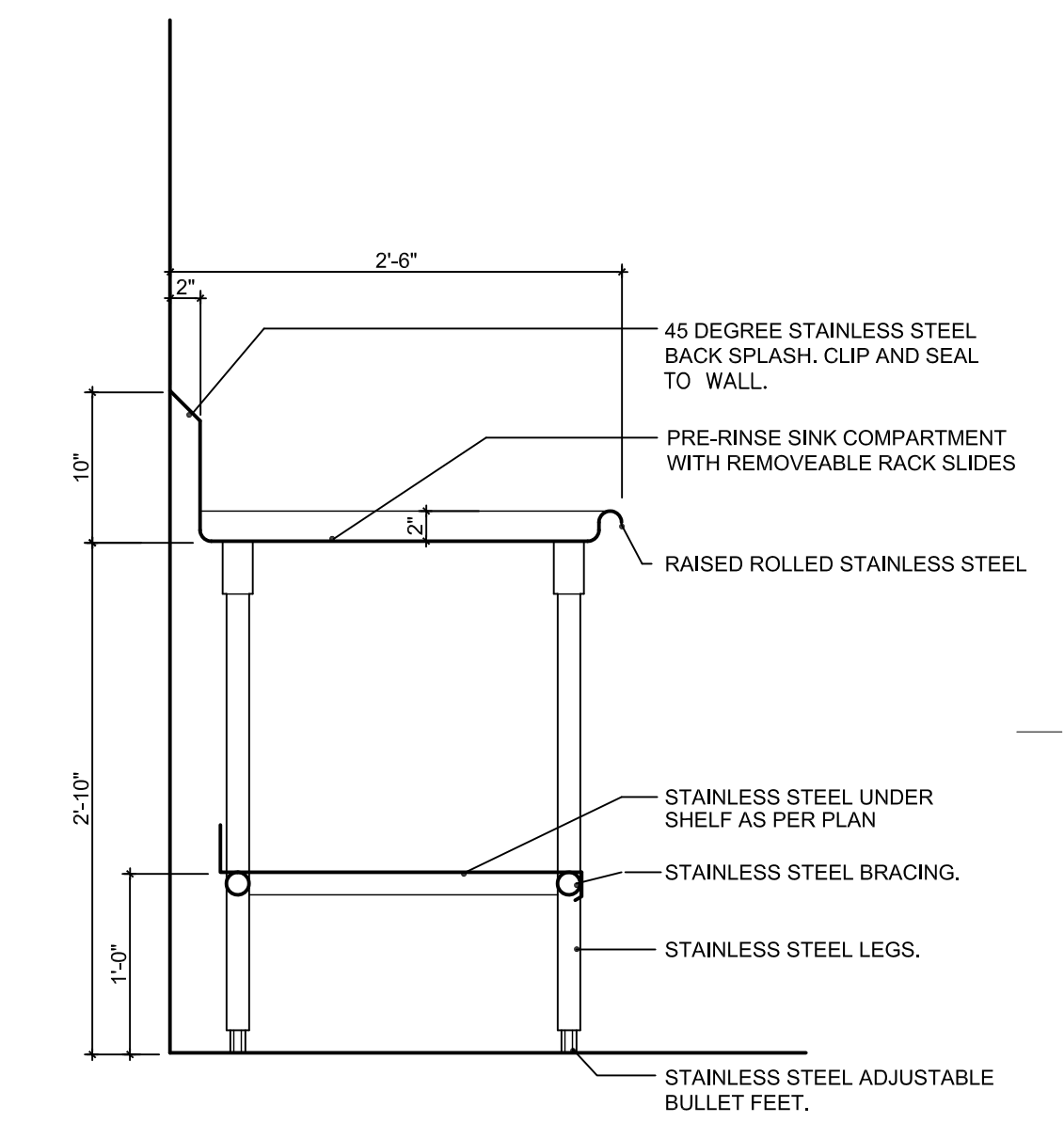

DISH TABLE, SHELF BASE SECTION DETAIL
SCALE: 1" = 1'-0"
FS101

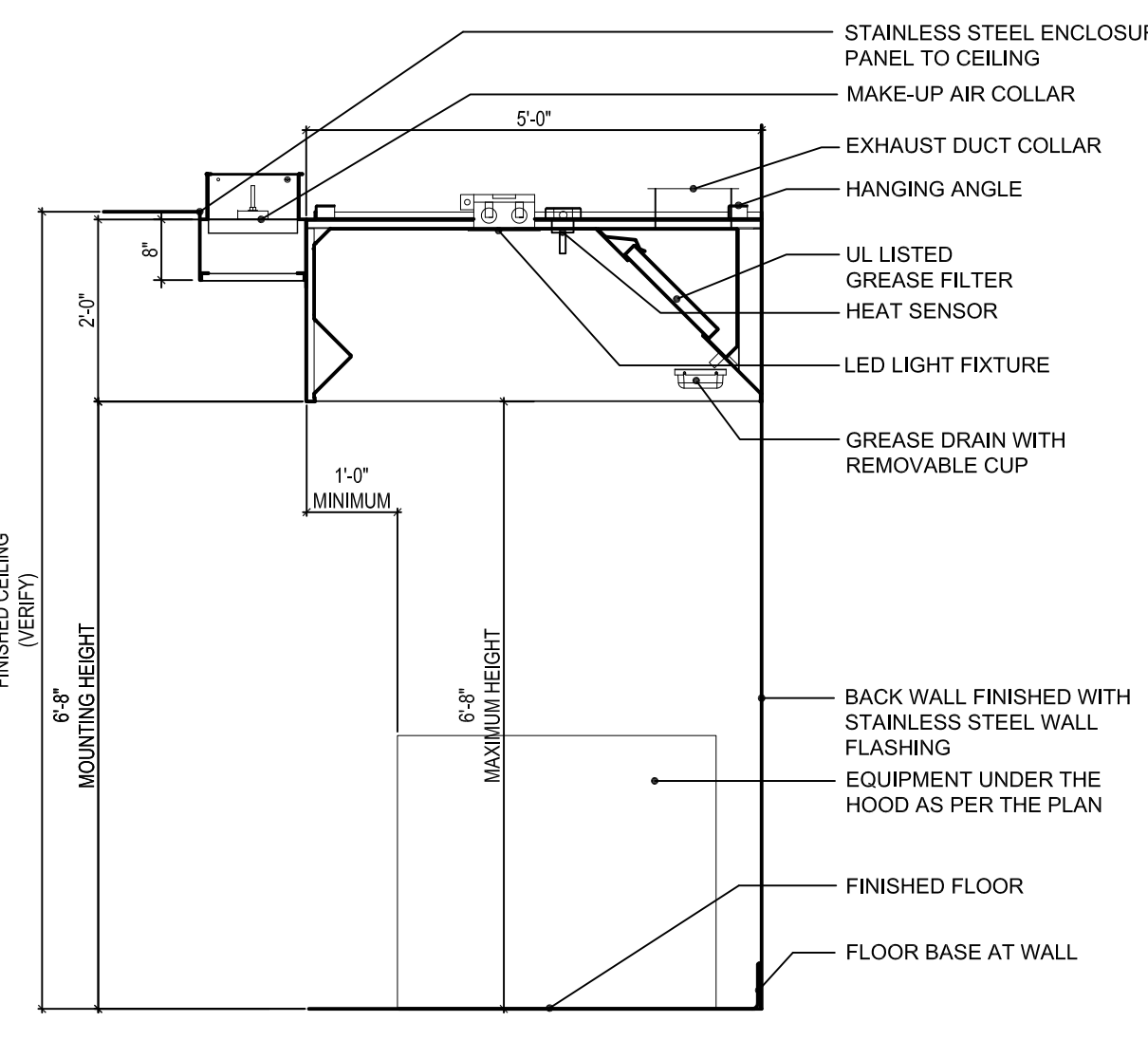

WALL CANOPY EXHAUST HOOD SECTION DETAIL
SCALE: 1/2" = 1'-0"
FS101

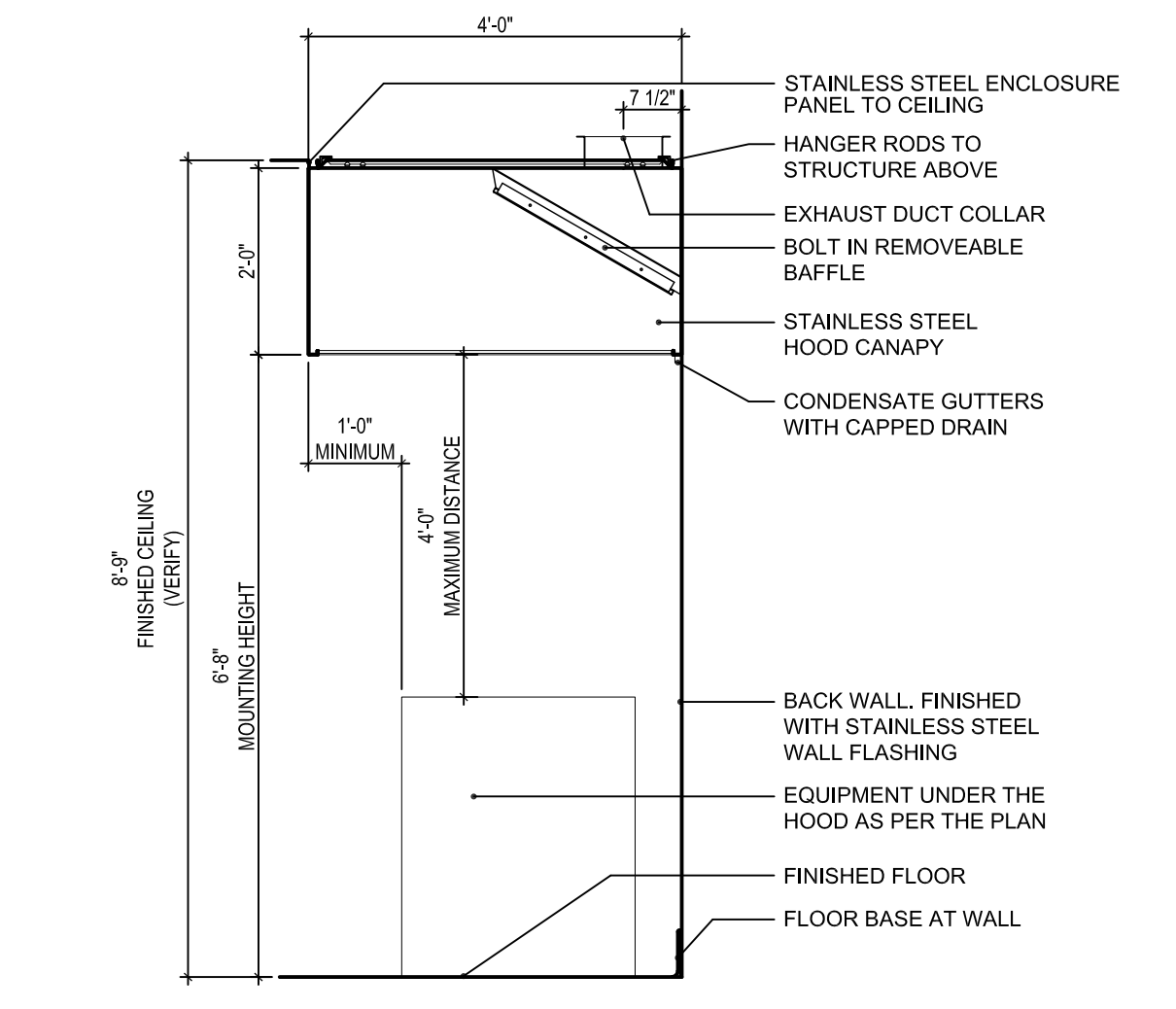

VENT HOOD: SINGLE WALL SECTION DETAIL
SCALE: 1/2" = 1'-0"
FS101

KITCHEN EQUIPMENT SCHEDULE

ITEM #	QTY	UNIT	DESCRIPTION OF EQUIPMENT
K-1	1	LOT	HIGH DENSITY DRY STORAGE SHELVING
K-2	1	LOT	DRY STORAGE SHELVING
K-3	1	LOT	WALK-IN COOLER BOX
K-4A	1	SYS	COOLER REFRIGERATION SYSTEM, REMOTE CONDENSER
K-4B	1	EACH	REFRIGERATION SYSTEM, EVAPORATOR COIL
K-5	1	LOT	COOLER SHELVING UNITS
K-6	1	LOT	COOLER DUNNAGE RACKS
K-7	4	EACH	MOBILE SPEED RACK
K-8	5	EACH	EMPLOYEE LOCKERS: STACKED, PROVIDED BY OTHER SECTION
K-9	1	EACH	MOP SINK: BY PLUMBING SECTION
K-10	-	-	SPARE NUMBER
K-11	1	EACH	JANITOR LOCKING WALL CABINET
K-12	1	LOT	STAINLESS STEEL CORNER GUARDS
K-13	2	EACH	WALL MOUNT HAND SINK: KNEE VALVE
K-14	1	EACH	ICE MACHINE AND BIN
K-15	1	EACH	STAINLESS STEEL TWO COMPARTMENT PREP SINK
K-16	1	EACH	PRE-RINSE SPRAY FAUCET, LOW PROFILE
K-17	1	EACH	STAINLESS STEEL WALL SHELF
K-18	1	LOT	STAINLESS STEEL WALL FLASHING
K-19	1	LOT	KITCHEN SHELVING
K-20	-	-	SPARE NUMBER
K-21	1	EACH	STAINLESS STEEL WORK TABLE
K-22	1	EACH	STAINLESS STEEL WALL SHELF
K-23	1	EACH	SLICER: AUTOMATIC
K-24	1	EACH	60 QUART MIXER
K-25	2	EACH	STAINLESS STEEL WORK TABLE
K-26	1	EACH	FOOD PROCESSOR
K-27	1	EACH	MICROWAVE OVEN
K-28	1	EACH	STAINLESS STEEL ISLAND WORK TABLE
K-29	1	EACH	STAINLESS STEEL UTENSIL RACK
K-30	-	-	SPARE NUMBER
K-31	1	EACH	STAINLESS STEEL ISLAND WORK TABLE
K-32	2	EACH	STAINLESS STEEL EXHAUST HOOD: TYPE I, WITH MUA PLENUM
K-33	1	SYS	HOOD FIRE PROTECTION SYSTEM
K-34	1	LOT	STAINLESS STEEL WALL FLASHING
K-35	1	EACH	STACKED CONVECTION OVEN: ELECTRIC
K-36	1	EACH	STACKED CONVECTION OVEN: ELECTRIC, EXISTING TO BE RE-USED
K-37	1	EACH	COMB-OVEN: STACKED, ELECTRIC
K-38	1	EACH	STEAMER, ELECTRIC
K-39	-	-	SPARE NUMBER
K-40	-	-	SPARE NUMBER
K-41	2	EACH	HOT FOOD HOLDING CABINET: EXISTING TO BE RE-USED
K-42	1	EACH	REACH-IN REFRIGERATOR: SINGLE SECTION
K-43	1	EACH	STAINLESS STEEL SERVING COUNTER: WITH STONE TOP
K-44	2	EACH	STAINLESS STEEL BREATH PROTECTOR: WITH TOP SHELF
K-45	1	EACH	HOT FOOD WELLS: FOUR SECTION SLIM LINE
K-46	1	EACH	HOT FOOD WELLS: THREE SECTION SLIM LINE
K-47	1	EACH	STAINLESS STEEL WALL SHELF
K-48	1	EACH	STAINLESS STEEL WALL SHELF
K-49	2	EACH	CASH REGISTER STAND: MOBILE, EXISTING TO BE RE-USED
K-50	2	EACH	TRAY AND UTENSIL CART
K-51	1	EACH	MILK COOLERS: MOBILE, EXISTING TO BE RE-USED
K-52	1	EACH	NUTRITION CART: MOBILE, EXISTING TO BE RE-USED
K-53	1	EACH	STAINLESS STEEL SOILED DISH TABLE
K-54	1	EACH	STAINLESS STEEL WALL MOUNT RACK SHELF
K-55	1	EACH	DISPOSER
K-56	1	EACH	PRE-RINSE SPRAY FAUCET
K-57	1	EACH	DISH MACHINE: ELECTRIC
K-58	1	EACH	STAINLESS STEEL VENT HOOD: TYPE II
K-59	1	LOT	STAINLESS STEEL WALL FLASHING
K-60	-	-	SPARE NUMBER
K-61	-	-	SPARE NUMBER
K-62	1	EACH	STAINLESS STEEL CLEAN DISH TABLE
K-63	1	EACH	STAINLESS STEEL WALL SHELF
K-64	1	EACH	STAINLESS STEEL FOUR COMPARTMENT SINK
K-65	1	EACH	DISPOSER
K-66	1	EACH	PRE-RINSE SPRAY FAUCET
K-67	1	EACH	STAINLESS STEEL WALL SHELF: TWO SECTION
K-68	1	LOT	STAINLESS STEEL WALL FLASHING
K-69	1	EACH	HOSE REEL
#E-01	1	EACH	BASE COMPUTER: PROVIDED BY OWNER
#E-02	2	EACH	CASH REGISTER COMPUTER: PROVIDED BY OWNER

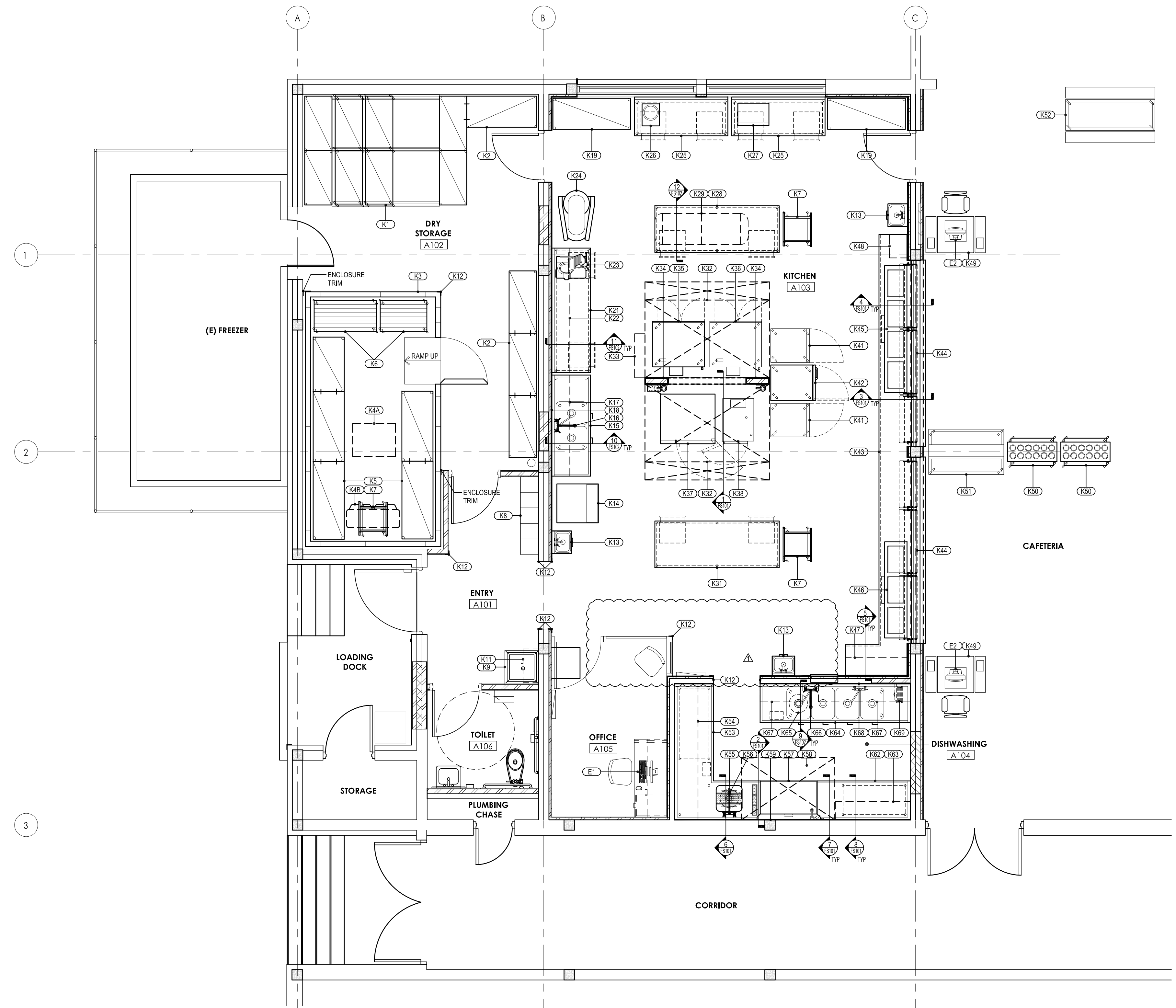

1 Food Service Equipment Plan
SCALE: 1/4" = 1'-0"

Ogden City School District
Highland Junior High School
Kitchen Remodel

NJRA Project # 19709.00
Bid Set January 30, 2020
Add #1 February 17, 2020

Food Service
Equipment Plan

FS101

325 Gramercy Ave
Ogden, Utah 84404

PRELIMINARY
NOT FOR
CONSTRUCTION



Jedziewski Designs
1537 Yale Avenue
Salt Lake City, Utah 84105
(801) 582-8747 Office
(801) 403-8073 Cell
JedziewskiDesigns.com

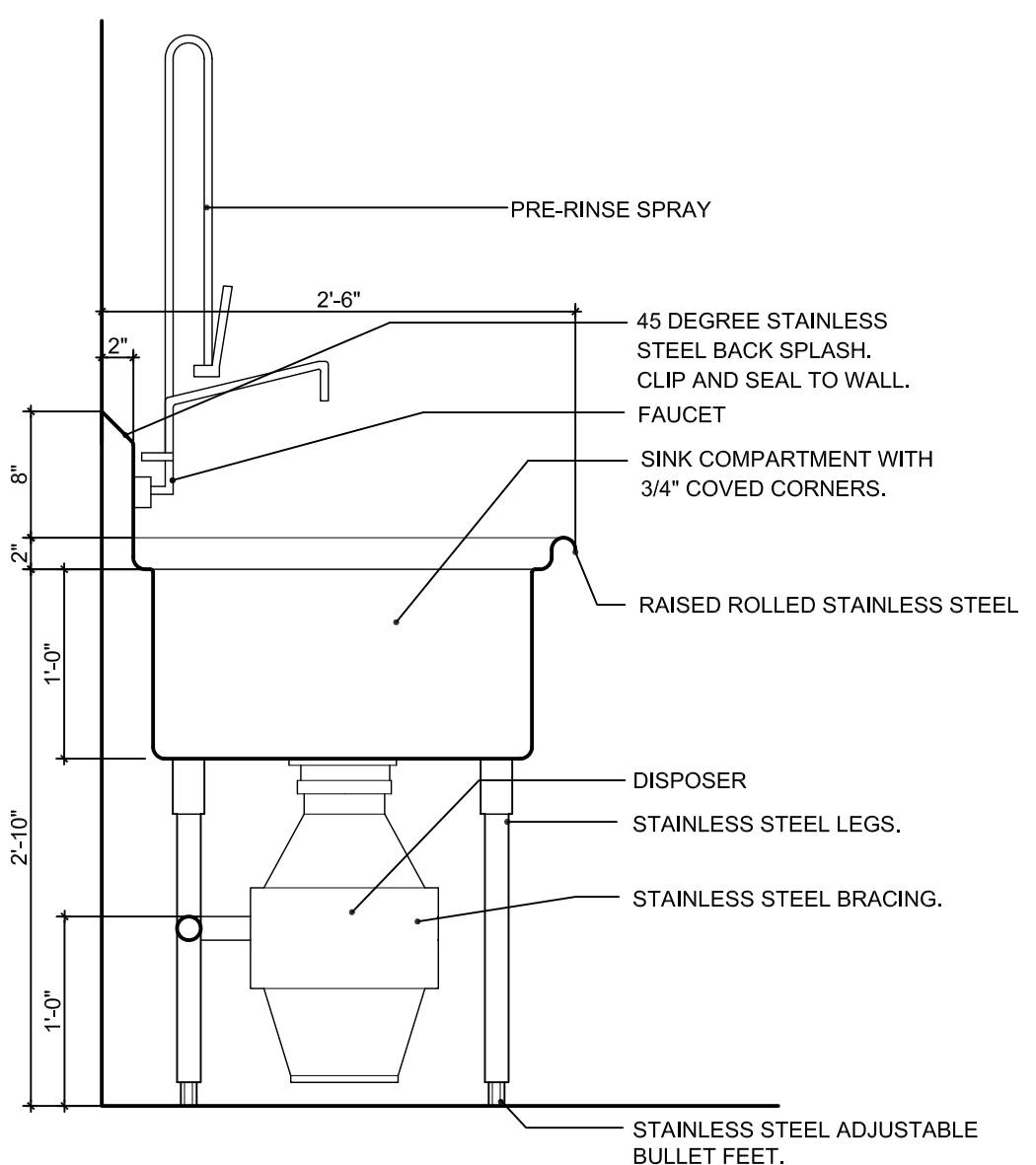

POT SINK SECTION DETAIL
SCALE: 1" = 1'-0"

9
FS102

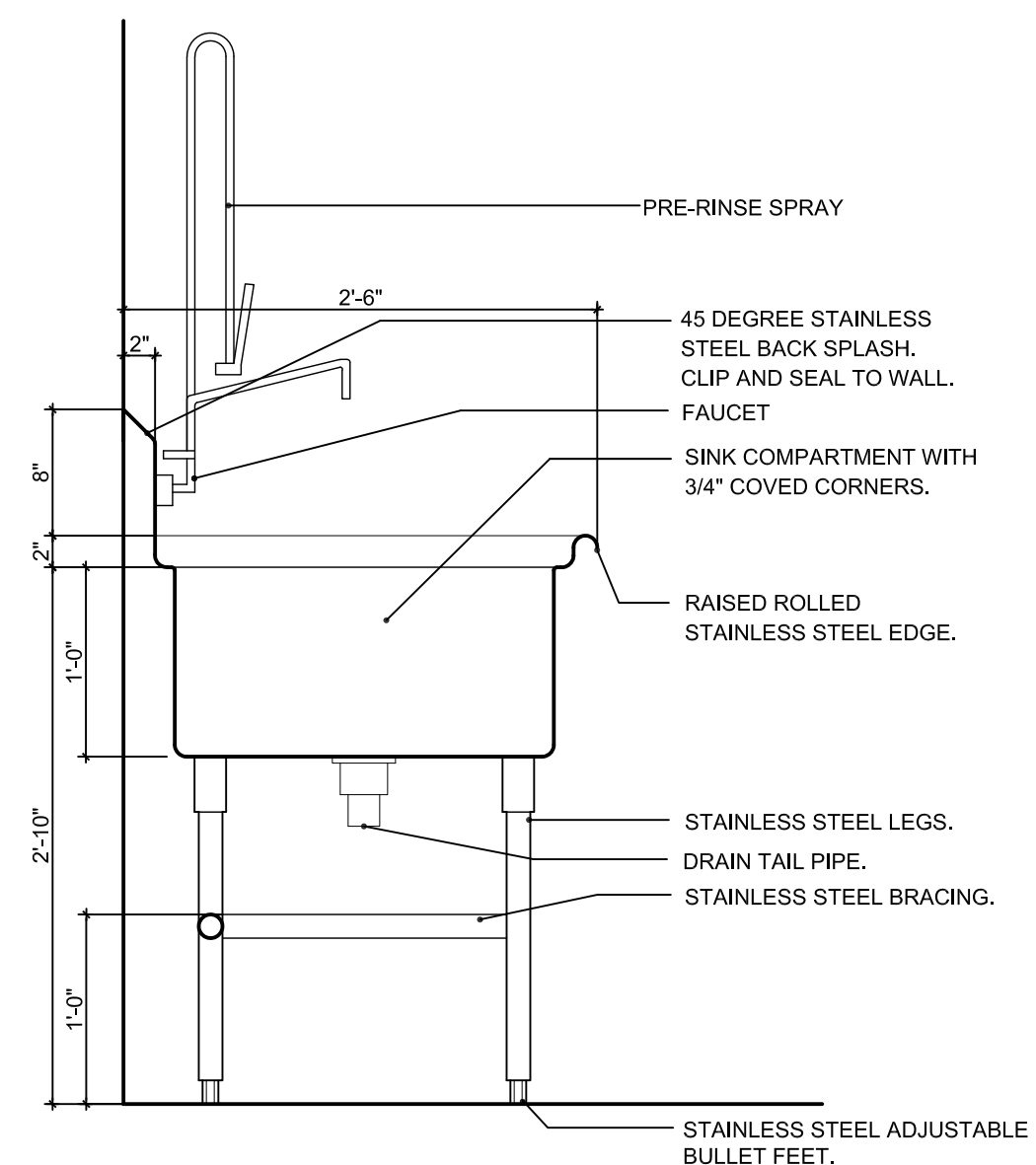

PREP SINK SECTION DETAIL
SCALE: 1" = 1'-0"

10
FS102

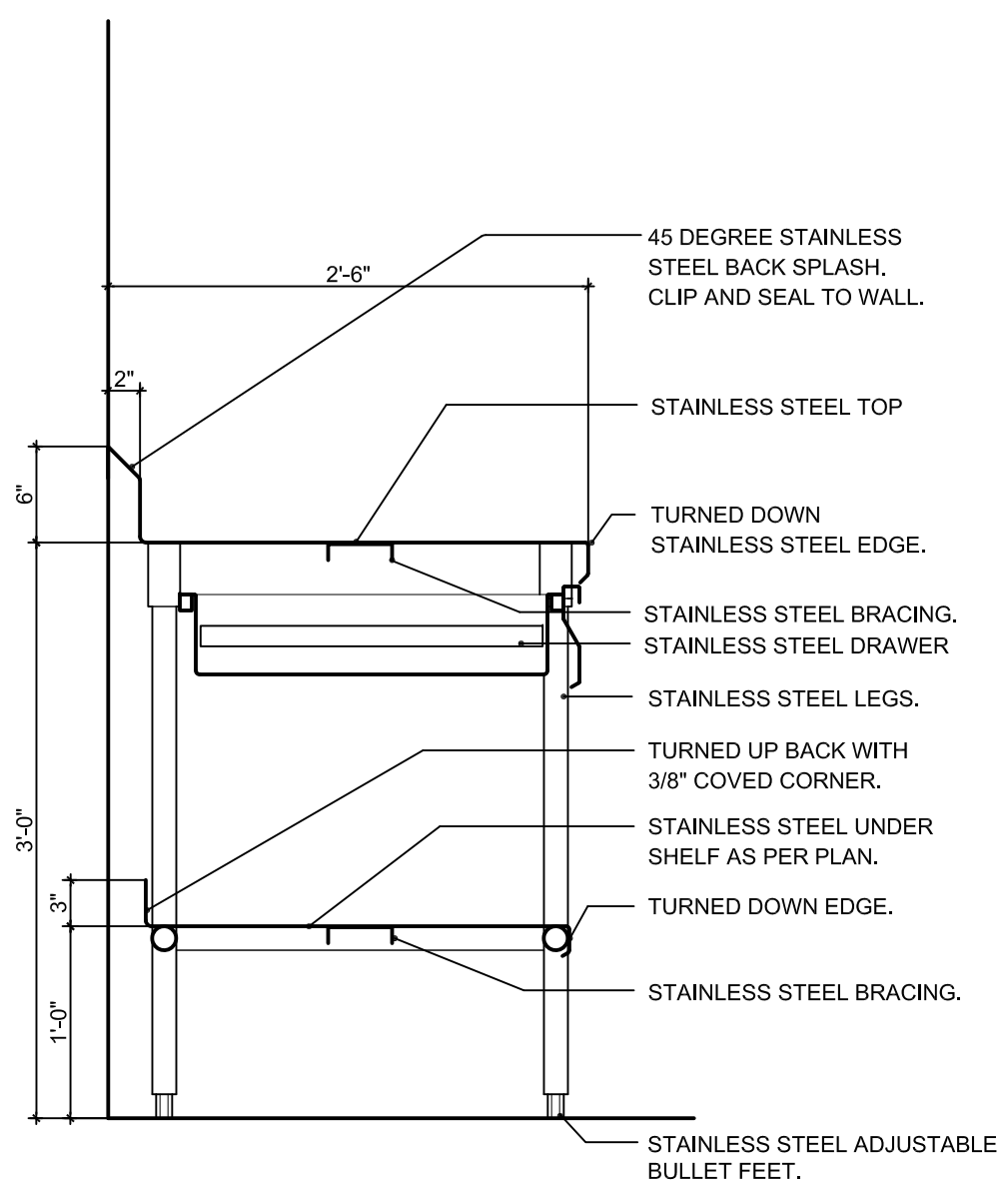

WORK TABLE, WALL SECTION DETAIL
SCALE: 1" = 1'-0"

11
FS102

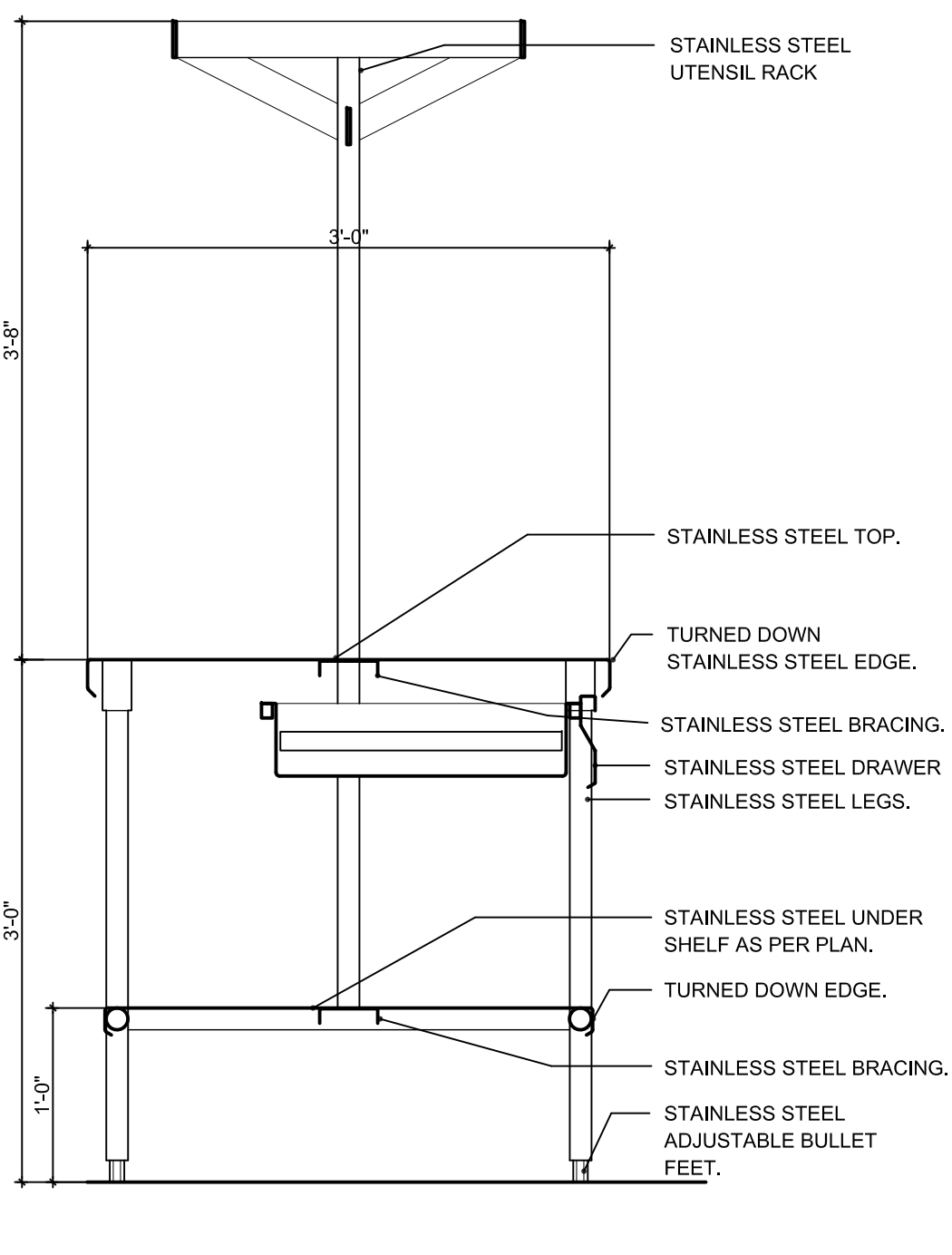

ISLAND WORK TABLE SECTION DETAIL
SCALE: 1" = 1'-0"

12
FS102

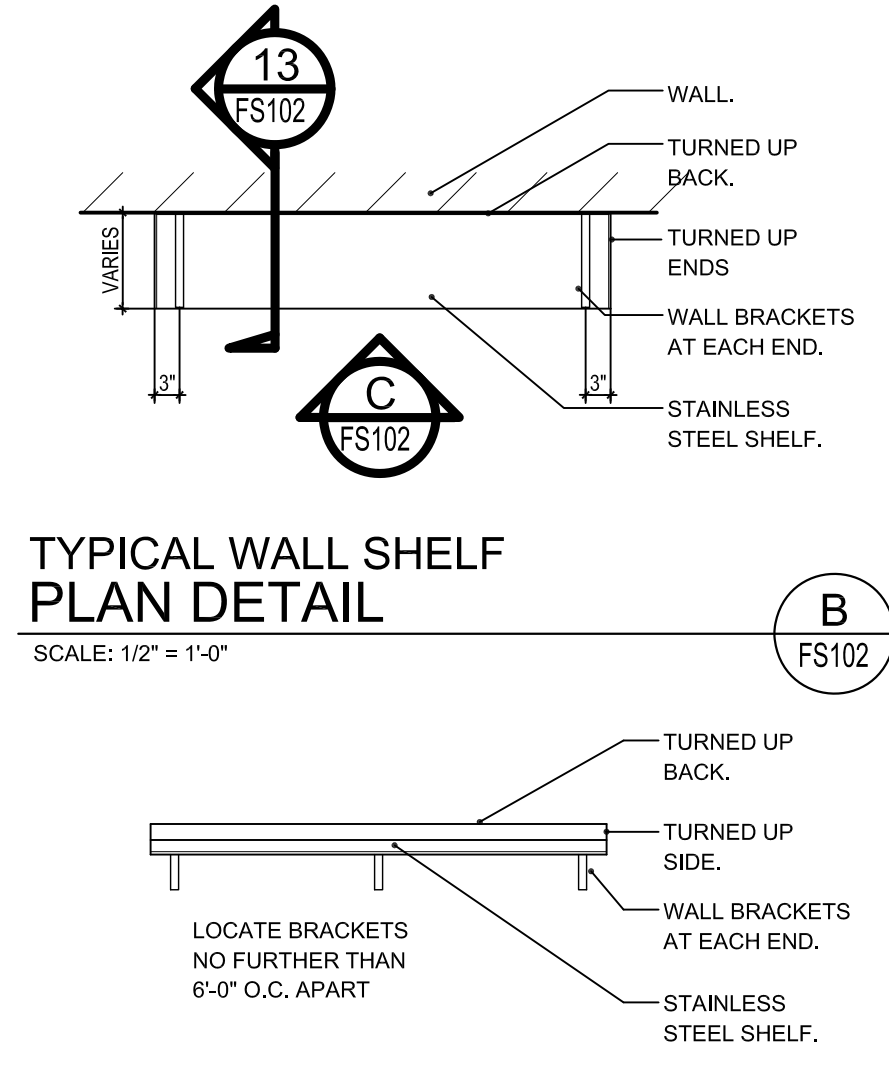

TYPICAL WALL SHELF PLAN DETAIL
SCALE: 1/2" = 1'-0"

B
FS102

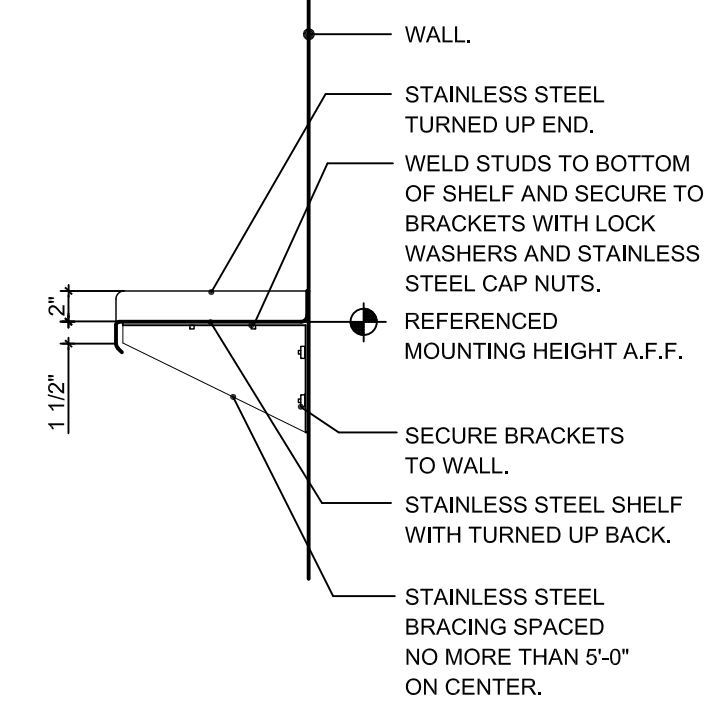

TYPICAL WALL SHELF SECTION DETAIL
SCALE: 1" = 1'-0"

13
FS102

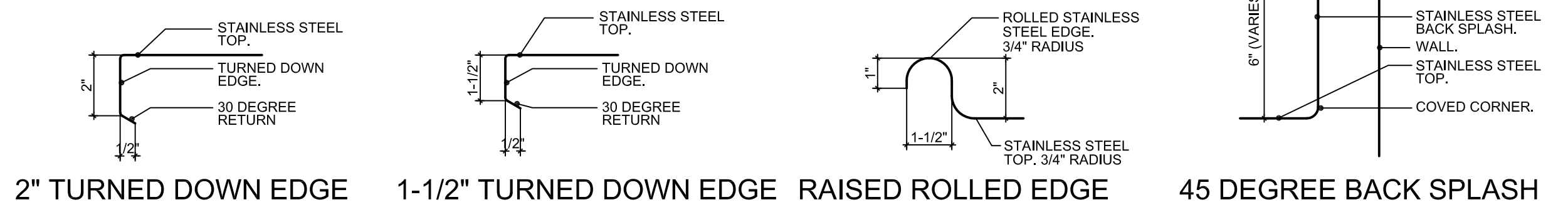

TYPICAL EDGE DETAILS SECTION DETAIL
SCALE: 1" = 1'-0"

14
FS102

BUILDING REQUIREMENTS
GENERAL NOTES:

- A. See Plumbing Rough-In Plan for requirements for drains, water, gas and refrigeration lines.
- B. See Electrical Rough-In Plan for requirements for outlets, junction boxes, loads, voltages, and phases.
- C. See Mechanical and Electrical Plans for requirements of ventilation systems.
- D. Verify blocking requirements with suppliers for those items not provided by Kitchen Equipment Contractor.
- E. All dimensions are to be field verified for compliance prior to fabrication/installation. All Dimensions shown are critical and are from finished wall.
- F. See Plumbing, Electrical and Mechanical Plans for further information and requirements.

GENERAL NOTE: ALL PENETRATIONS TO THE WALK-IN BOX ARE TO BE SEALED ALL THE WAY THROUGH BY THE CONTRACTOR WHO MADE THEM.

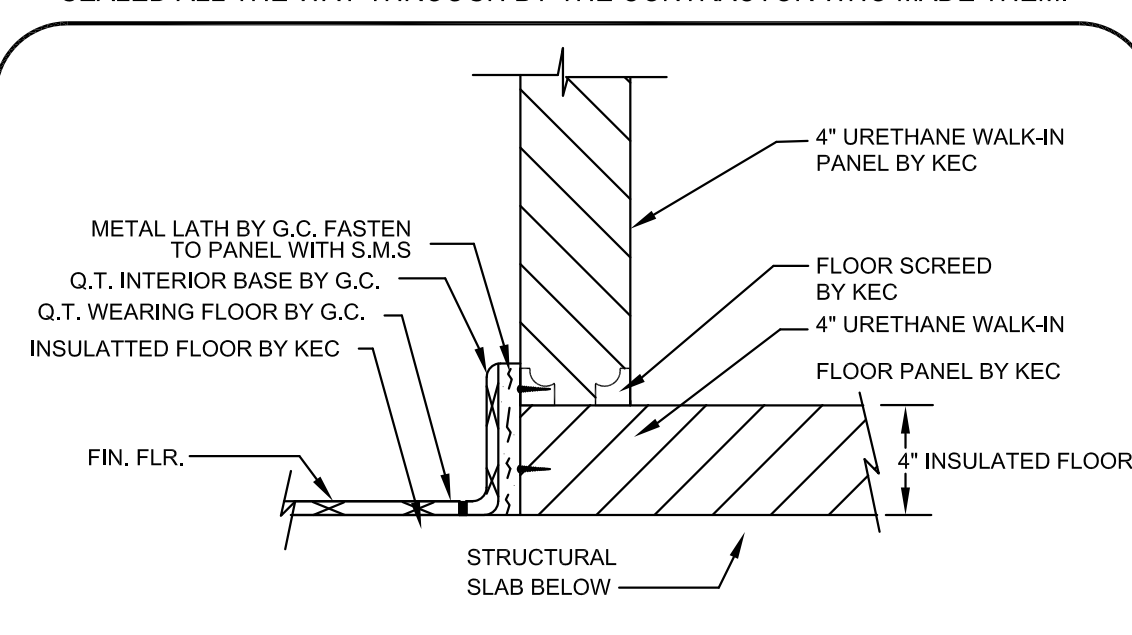

WALK-IN WALL AND FLOOR INTEGRAL INSULATED FLOOR

BUILDING REQUIREMENT SCHEDULE

- BUILDING REQUIREMENTS ARE TO BE PROVIDED AS PART OF THE GENERAL CONTRACT EXCEPT AS NOTED
- (A1) K.E.C. TO PROVIDE INTEGRAL INSULATED FLOOR PANEL SYSTEM AT WALK-IN COOLER WITH INTERNAL RAMP. SEE DETAILS AND MANUFACTURER'S SHOP DRAWINGS
 - (A2) WALK-IN FREEZER/COOLER BOX SET ON SUB FLOOR. G.C. TO PROVIDE FLOOR TILE AND COVER BASE TO EXTEND TO EXPOSED WALK-IN PANELS AND INTO INTERNAL RAMP.
 - (A3) G.C. TO PROVIDE CHASE THROUGH BUILDING AS REQUIRED FOR REFRIGERATION LINES FROM EVAPORATOR COILS TO REMOTE REFRIGERATION UNIT ON ROOF ABOVE. VERIFY LOCATION.
 - (A4) REFRIGERATION LINE SET CONNECTION AT SYSTEM CONDENSERS. ITEMS #K-4A BY K.E.C. TO BE LOCATED ON ROOF ABOVE.
 - (A5) REFRIGERATION LINE SETS BY K.E.C. FROM CONDENSERS ON ROOF ABOVE TO EVAPORATOR COILS IN WALK-IN BOX.
 - (A6) REFRIGERATION LINE SET CONNECTIONS AT SYSTEM EVAPORATOR COILS. ITEMS #K-4B BY K.E.C. TO BE MOUNTED FROM CEILING PANEL OF THE WALK-IN BOX.
 - (A7) G.C. TO PROVIDE BLOCKING IN WALL FOR WALL SHELF. SEE DETAIL 'A'
 - (A8) G.C. TO PROVIDE BLOCKING IN WALL FOR PRE-RINSE FAUCET. SEE DETAIL 'B'
 - (A9) G.C. TO PROVIDE BLOCKING IN WALL FOR EXHAUST HOOD. SEE DETAIL 'C'
 - (A10) G.C. TO PROVIDE BLOCKING IN WALL FOR HAND SINK. SEE DETAIL 'D'
 - (A11) G.C. TO PROVIDE BLOCKING IN WALL FOR POT RACK. SEE DETAIL 'E'
 - (A12) G.C. TO PROVIDE BLOCKING IN HOSE REEL. SEE DETAIL 'F'
 - (A13) G.C. TO PROVIDE BLOCKING IN WALL WALL CABINET. SEE DETAIL 'G'
 - (A14) ITEM #K-32 EXHAUST HOOD BY K.E.C. TWO EACH CANOPY BOX STYLE. TYPE I. MOUNT FROM STRUCTURE ABOVE AND TO BACK WALL. SEE HOOD SECTION DETAIL.
 - (A15) EXHAUST DUCT COLLAR. (1) EACH 12" DIAMETER REQUIRED AT 160 CFM EACH FOR A TOTAL EXHAUST OF 3200 CFM AT 0.51" STATIC PRESSURE AND 140' DUCT VELOCITY.
 - (A16) MAKE-UP AIR DUCT COLLARS. (4) EACH 8" X 30" REQUIRED AT 640 CFM EACH FOR A TOTAL OF 2560 MAKE-UP AIR AT 0.18" STATIC PRESSURE.
 - (A17) G.C. TO PROVIDE NON-COMBUSTIBLE CONSTRUCTION ASSEMBLIES WITHIN 18" OF EXHAUST HOOD.
 - (A18) ITEM #K-58 VAPOR EXHAUST VENT HOOD BY K.E.C. CANOPY BOX STYLE. TYPE II ONE SECTION. MOUNT FROM STRUCTURE ABOVE AND TO BACK WALL.
 - (A19) EXHAUST DUCT CONNECTION. (1) EACH 12" DIAMETER REQUIRED FOR A TOTAL EXHAUST OF 80 CFM AT 0.18" STATIC PRESSURE AND 140' DUCT VELOCITY.
 - (A20) MAKE-UP AIR AT 80% OF EXHAUSTED AIR OR A TOTAL OF 720 CFM. TO BE PROVIDED TO THE SPACE THROUGH A MAKE-UP SYSTEM PROVIDED BY THE MECHANICAL SYSTEM.
 - (A21) MECHANICAL SYSTEM TO PROVIDE VENTILATION AT REACH-IN REFRIGERATOR TO EXHAUST 5.0 MBTU PER HOUR.
 - (A22) MECHANICAL SYSTEM TO PROVIDE VENTILATION AT ICE MAKER TO EXHAUST 13.9 MBTU PER HOUR.
 - (A23) MECHANICAL SYSTEM TO PROVIDE MAXIMUM TO DEGREE F. IN DRY STORAGE ROOM.
 - (A24) LOW WALL TO SUPPORT SERVING COUNTER TOP. WITH FINISHED HEIGHT AT TOP OF COUNTER TRAY SLIDE AT +3' A.F.F. AND +3' A.F.F. AT SERVING TOP. FINISHED BOTH SIDES. SEE ARCHITECTURAL DETAILS.
 - G.C. TO PROVIDE RECESS OPENING IN WALL FOR HOOD CONTROL PANEL. SEE MANUFACTURER'S SHOP DRAWINGS FOR REQUIREMENTS.
 - K.E.C. - KITCHEN EQUIPMENT CONTRACTOR
 - G.C. - GENERAL CONTRACTOR

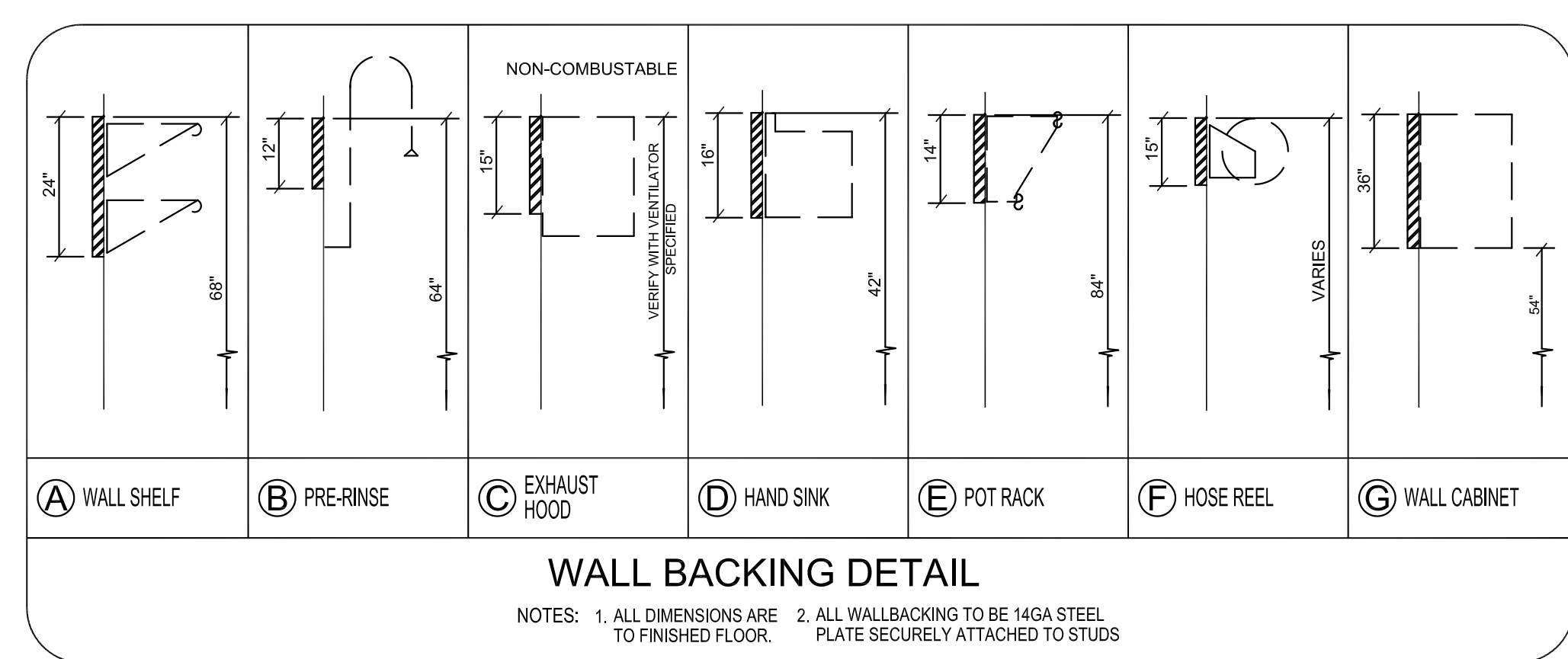

WALL BACKING DETAIL
NOTES: 1. ALL DIMENSIONS ARE TO FINISHED FLOOR. 2. ALL WALLBACKING TO BE 14GA STEEL PLATE SECURELY ATTACHED TO STUDS

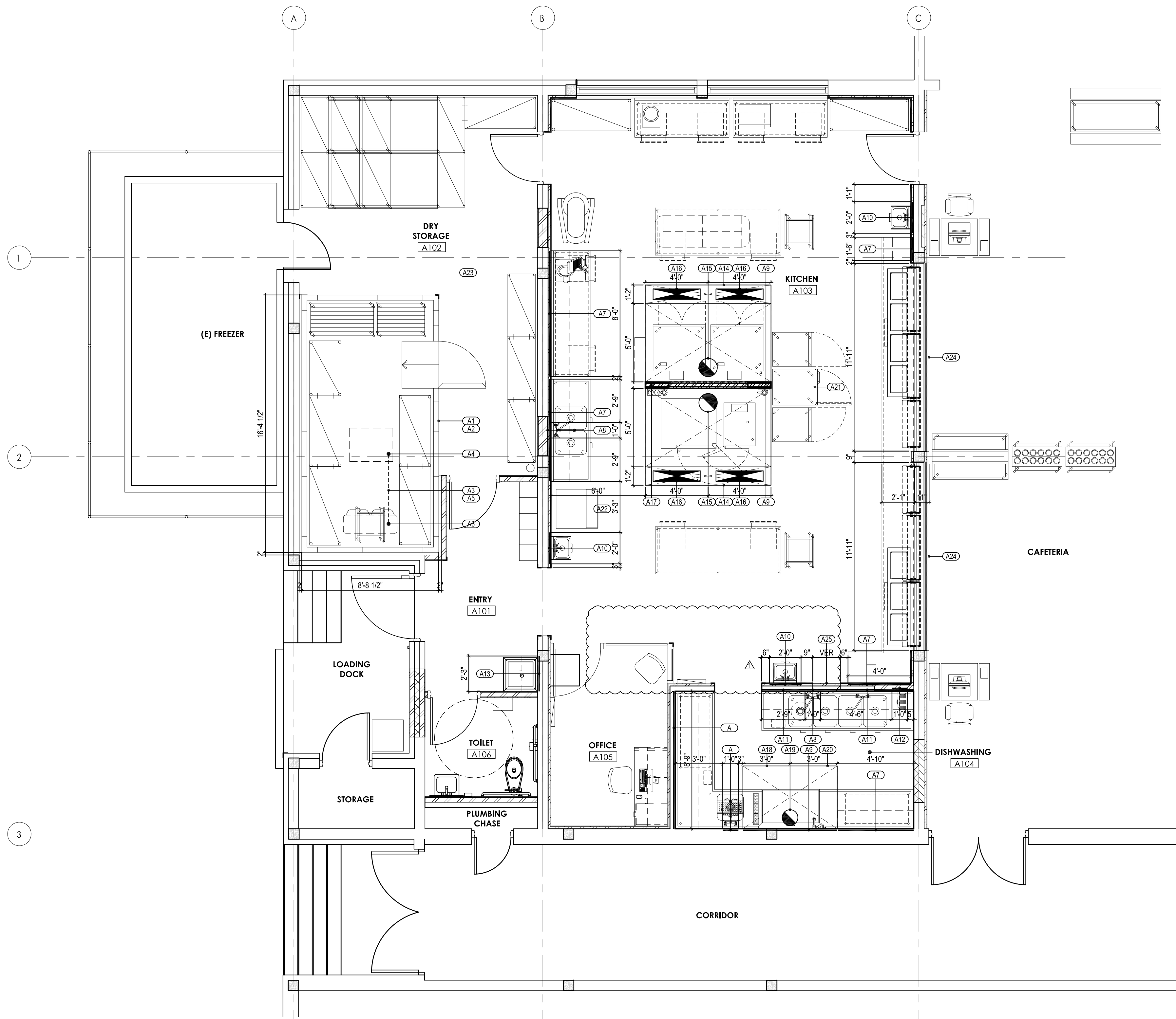

1 Food Service Equipment Building Requirement Plan
SCALE: 1/4" = 1'-0"

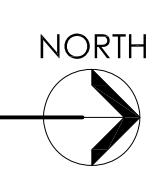

Ogden City School District
Highland Junior High School
Kitchen Remodel

325 Gramercy Ave
Ogden, Utah 84404

NJRA Project # 19709.00
Bid Set January 30, 2020
Add #1 February 17, 2020

Food Service
Equipment Building
Requirement Plan

FS102

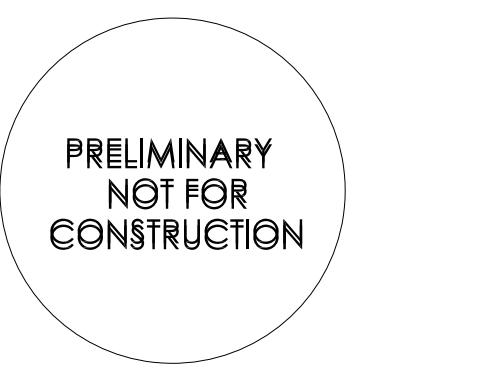

ELECTRICAL NOTES

- ELECTRICAL PLAN SHOWS ROUGH-IN POINTS AND SCHEDULED CONNECTIONS. KITCHEN EQUIPMENT CONTRACTOR WILL PROVIDE DIMENSIONED ROUGH-IN DRAWINGS FOR CONSTRUCTION.
- ELECTRICAL SYSTEM IS DESIGNED FOR 120/208 VOLTS, 1&3, PHASE, 60 HERTZ, 4-WIRE SYSTEM.
- ELECTRICAL DIVISION SHALL FURNISH AND INSTALL ALL JUNCTION BOXES, RECEPTACLES, COVER PLATES, PULL BOXES, CONDUIT AND WIRING EXCEPT WHERE NOTED. RECEPTACLES AND COVER PLATES SHALL BE BRUSHED STAINLESS STEEL FURNISHED BY ELECTRICAL DIVISION.
- KITCHEN EQUIPMENT CONTRACTOR SHALL FURNISH AND INSTALL VAPOR PROOF VENTILATOR LIGHTS COMPLETE WITH LAMPS. INTERCONNECTING CONDUIT AND WIRE BETWEEN SWITCH, DISPOSER AND COMPONENTS.
- ADDITIONAL CONVENIENCE RECEPTACLES, TELEPHONE AND INTERCOM JACKS AND TEMPERATURE MONITORING SYSTEM ETC. SHALL BE LOCATED BY THE ELECTRICAL ENGINEER/ARCHITECT AND AS REQUIRED BY CODE.
- KITCHEN EQUIPMENT CONTRACTOR SHALL FURNISH DISPOSER CONTROLS. ELECTRICAL DIVISION SHALL FURNISH AND INSTALL INTER-CONNECTING CONDUIT AND WIRE BETWEEN SWITCH, DISPOSER AND COMPONENTS.
- PRE-FABRICATED COLD STORAGE ROOMS ARE FURNISHED BY THE KITCHEN EQUIPMENT CONTRACTOR COMPLETE WITH SPLICE BOXES, LIGHT FIXTURES, LAMPS, LIGHT SWITCHES AND DOOR HEATERS. ELECTRICAL DIVISION TO INSTALL SAME AND SHALL FURNISH AND INSTALL INTERCONNECTING CONDUIT, WIRING SEALOFFS, SEALANT AND MAKE FINAL CONNECTIONS.
- ELECTRICAL DIVISION SHALL FURNISH AND INSTALL ALL INTERCONNECTING CONDUIT AND WIRING BETWEEN KITCHEN EQUIPMENT CONTRACTOR FURNISHED LOW TEMP COLD STORAGE ROOM EVAPORATOR TERMINAL BLOCK, SWITCH, FAN DOOR SWITCH AND COMPRESSOR CONTROL PANEL.
- ELECTRICAL DIVISION SHALL FURNISH AND INSTALL EMPTY CONDUIT WITH JUNCTION BOXES FOR INSTALLATION OF OWNER SUPPLIED I.T. EQUIPMENT DIVISION POS/ ELECTRONIC CASH CONTROL SYSTEM. ELECTRICAL DIVISION TO VERIFY INSTALLATION IN ACCORDANCE WITH OWNER'S REQUIREMENTS AND MANUFACTURER'S INSTRUCTIONS.

ELECTRICAL LEGEND

- ⊕ ELECTRICAL OUTLET
- ⊞ JUNCTION BOX
- ⊕ CONVENIENCE DUPLEX RECEPTACLE
- ⊕ FLEX CONNECTION (CONTINUOUS WIRE FROM ROUGH-IN TO JUNCTION/OUTLET LOCATION)
- ⊕ DATA CONDUIT
- ⊕ SWITCH
- ⊕ CONTROLS
- ⊕ STUB FROM FLOOR
- ⊕ DROP FROM ABOVE
- ⊕ FLOOR MOUNTED

NOTE: ELECTRICAL MOUNTING

ALL WALL MOUNT ELECTRICAL RECEPTACLE AND J-BOXES ARE TO BE FLUSH MOUNTED IN WALLS WITH NO EXPOSED CONDUIT SHOWING ON SURFACE OF WALLS. ARCHITECT TO PROVIDE MINIMUM WALL FURRING IF REQUIRED.

NOTE: POS ELECTRICAL

120V, 1 PHASE, SERVICE, 10.0 AMPS, STUB AS NOTED, FOR POS/PRE-CHECK SYSTEM STATIONS. (DEDICATED CIRCUIT, ISOLATED GROUND, PROVIDE (ADD PHONE LINE) EMPTY J-BOX WITH CONDUIT FOR INTERCONNECTING POS SYSTEM, PRE-CHECK AND PRINTERS) (VERIFY ALL REQUIREMENTS WITH POS SYSTEM SUPPLIER.)

NOTE: WALK-IN ELECTRICAL

ALL CONDUIT SHALL BE RUN ON THE EXTERIOR CEILING OF ALL COLD STORAGE ROOMS AND SHALL PENETRATE THE CEILING AT A POINT WHERE THE CONDUIT CAN DROP DIRECTLY TO THE POINT OF CONNECTION. UNDER NO CIRCUMSTANCES WILL ELECTRICAL CONDUIT BE PERMITTED ON THE INTERIOR.

ELECTRICAL ROUGH-IN/FINAL CONNECTION SCHEDULE

ROUGH-IN REQUIREMENTS	CONNECTION REQUIREMENTS	REMARKS				
#	ITEM #	DESCRIPTION	VOLTS/PH	LOAD	OSN	REMARKS
E-01	JUNCTION BOX	#K4A : WALK-IN COOLER REF. CONDENSER	208/60/1	11.4 AMP	J-BOX	VERIFY LOCATION OF REMOTE UNIT ON ROOF
E-02	JUNCTION BOX	#K4B : WALK-IN COOLER REF. BLOWER COILS	115/60/1	1.8 AMP	J-BOX	INTERCONNECT CONTROLS WITH REMOTE CONDENSER
E-03	DATA OUTLET	#K4B : COOLER REFRIGERATION SYSTEM	-	-	-	RUN CONDUIT FOR DATA CABLE TO OFFICE.
E-04	OUTLET	#K4B : TEMPERATURE MONITOR	120/60/1	2 AMP	C&P	-
E-05	JUNCTION BOX	#K3 : WALK-IN COOLER LIGHTS AND HEATER	115/60/1	4 AMP	J-BOX	INTERCONNECT THREE LIGHTS.
E-06	OUTLET	#E1 : POS COMPUTER	120/60/1	VERIFY	C&P	NOTE #1.
E-07	DATA OUTLET	#E1 : POS COMPUTER	-	-	-	NOTE #2.
E-08	JUNCTION BOX	#K14 : ICE MAKER	115/60/1	14.2 AMP	J-BOX	RE-USE EXISTING WHERE APPLICABLE.
E-09	CONVENIENCE OUTLET	#K21 : WORK TABLE	120/60/1	10 AMP	C&P	-
E-10	CONVENIENCE OUTLET	#K21 : WORK TABLE	120/60/1	10 AMP	C&P	-
E-11	OUTLET	#K23 : SLICER	120/60/1	5.8 AMP	C&P	-
E-12	JUNCTION BOX	#K24 : 60 QUART MIDER	208/60/3	10 AMP	J-BOX	-
E-13	OUTLET	#K26 : FOOD PROCESSOR	120/60/1	8 AMP	C&P	-
E-14	CONVENIENCE OUTLET	#K25 : WORK TABLE	120/60/1	10 AMP	C&P	-
E-15	OUTLET	#K27 : MICROWAVE OVEN	115/60/1	16.8 AMP	C&P	-
E-16	CONVENIENCE OUTLET	#K25 : WORK TABLE	120/60/1	10 AMP	C&P	-
E-17	OUTLET (FLEX)	STUB #K28 : WORK TABLE	120/60/1	10 AMP	C&P	NOTE #4. TWO EACH OUTLETS.
E-18	OUTLET (FLEX)	STUB #K31 : WORK TABLE	120/60/1	10 AMP	C&P	NOTE #4. TWO EACH OUTLETS.
E-19	NOT USED	-	-	-	-	-
E-20	JUNCTION BOX	#K32 : EXHAUST HOOD	120/60/1	600 WATT	J-BOX	INTERCONNECT FROM CONTROL PANEL TO MECHANICAL SYSTEM
E-21	JUNCTION BOX	#K32 : EXHAUST HOOD: HEAT SENSOR	120/60/1	15 AMP	J-BOX	INTERCONNECT TO DUCT HEAT SENSOR AND CONTROL BOX PROVIDED WITH HOOD. NOTE #5.
E-22	NOT USED	-	-	-	-	-
E-23	TEMPERATURE SENSOR	#K32 : EXHAUST HOOD: HEAT SENSOR SYSTEM	CONTROL WIRE	-	-	INTERCONNECT FROM CONTROL BOX PROVIDED WITH HOOD.
E-24	JUNCTION BOX	#K37 : COMB-OVEN	208/60/3	61.4 AMP	J-BOX	-
E-25	JUNCTION BOX	#K37 : COMB-OVEN	208/60/3	102.7 AMP	J-BOX	-
E-26	JUNCTION BOX	#K38 : STEAMER	208/60/3	91.7 AMP	J-BOX	-
E-27	JUNCTION BOX	#K35 : CONNECTION OVEN	208/60/3	35 AMP	J-BOX	-
E-28	JUNCTION BOX	#K35 : CONNECTION OVEN	208/60/3	35 AMP	J-BOX	-
E-29	JUNCTION BOX	#K36 : CONNECTION OVEN	208/60/3	35.2 AMP	J-BOX	NOTE #3.
E-30	JUNCTION BOX	#K36 : CONNECTION OVEN	208/60/3	35.2 AMP	J-BOX	NOTE #3.
E-31	OUTLET	#K41 : HOT FOOD WARMING CABINET	120/60/1	17.5 AMP	C&P	NOTE #3.
E-32	OUTLET	#K41 : REACH-IN REFRIGERATOR	115/60/1	3.8 AMP	C&P	-
E-33	OUTLET	#K41 : HOT FOOD WARMING CABINET	120/60/1	17.5 AMP	C&P	NOTE #3.
E-34	NOT USED	-	-	-	-	-
E-35	JUNCTION BOX	#K35 : DISPOSER	208/60/3	2 HP	J-BOX	INTERCONNECT CONTROLS
E-36	JUNCTION BOX	#K57 : DISHWASHER	208/60/3	55.0 AMP	J-BOX	INTERCONNECT CONTROLS & TANK HEAT.
E-37	JUNCTION BOX	#K57 : DISHWASHER: BOOSTER HEATER	208/60/3	83.9 AMP	J-BOX	BOOSTER HEATER.
E-38	SWITCH/CONTROLS	#K58 : VENT HOOD: SWITCH	120/60/1	-	-	INTERCONNECT WITH VENT HOOD EXHAUST SYSTEM.
E-39	JUNCTION BOX	#K65 : DISPOSER	208/60/3	2 HP	J-BOX	INTERCONNECT WITH CONTROLS.
E-40	CONVENIENCE OUTLET	#K43 : SERVING COUNTER	120/60/1	10 AMP	C&P	-
E-41	CONVENIENCE OUTLET	#K43 : SERVING COUNTER	120/60/1	10 AMP	C&P	-
E-42	JUNCTION BOX	#K45 : HOT/COLD/FROZEN FOOD WELLS	208/60/1	23.7 AMP	J-BOX	INTERCONNECT CONTROLS.
E-43	CONVENIENCE OUTLET	#K43 : SERVING COUNTER	120/60/1	10 AMP	C&P	-
E-44	JUNCTION BOX	#K45 : HOT/COLD/FROZEN FOOD WELLS	208/60/1	18.7 AMP	J-BOX	INTERCONNECT CONTROLS.
E-45	CONVENIENCE OUTLET	#K43 : SERVING COUNTER	120/60/1	10 AMP	C&P	-
E-46	OUTLET	#E2 : POS COMPUTER	-	-	-	NOTE #1.
E-47	DATA OUTLET	#E2 : POS COMPUTER	-	-	-	NOTE #2.
E-48	OUTLET	#K51 : MILK COOLER	115/60/1	8.2 AMP	C&P	NOTE #3.
E-49	OUTLET	#E2 : POS COMPUTER	-	-	-	NOTE #1.
E-50	DATA OUTLET	#E2 : POS COMPUTER	-	-	-	NOTE #2.

NOTE #1: VERIFY THE REQUIREMENTS OF THE POS SYSTEM WITH THE SUPPLIER INCLUDING ELECTRICAL REQUIREMENTS AND THE INTERCONNECTION REQUIREMENTS.
NOTE #2: PROVIDE DATA CONDUIT AS REQUIRED BY POS SUPPLIER. VERIFY INTERCONNECTION REQUIREMENTS BETWEEN COMPONENTS OF SYSTEM.
NOTE #3: VERIFY REQUIREMENTS OF EXISTING EQUIPMENT BEING RE-USED.
NOTE #4: RUN FLEX FROM STUBBED LOCATION TO JUNCTION BOX MOUNTED AT UNDERSIDE OF WORK TABLE. OUTLETS ARE PRE-WIRED AS PART OF TABLE.
NOTE #5: ELECTRICIAN TO FIELD WIRE LOW VOLTAGE FROM EACH TEMPERATURE CONTROLLER TO HEAT SENSOR PROVIDED WITH HOOD AT EACH EXHAUST RISER. ELECTRICIAN TO INTERLOCK CONTACTORS OR STARTERS SPECIFIED BY MECHANICAL SYSTEM TO THE CONTACTS AT THE TERMINAL BLOCK TO OPERATE FAN.

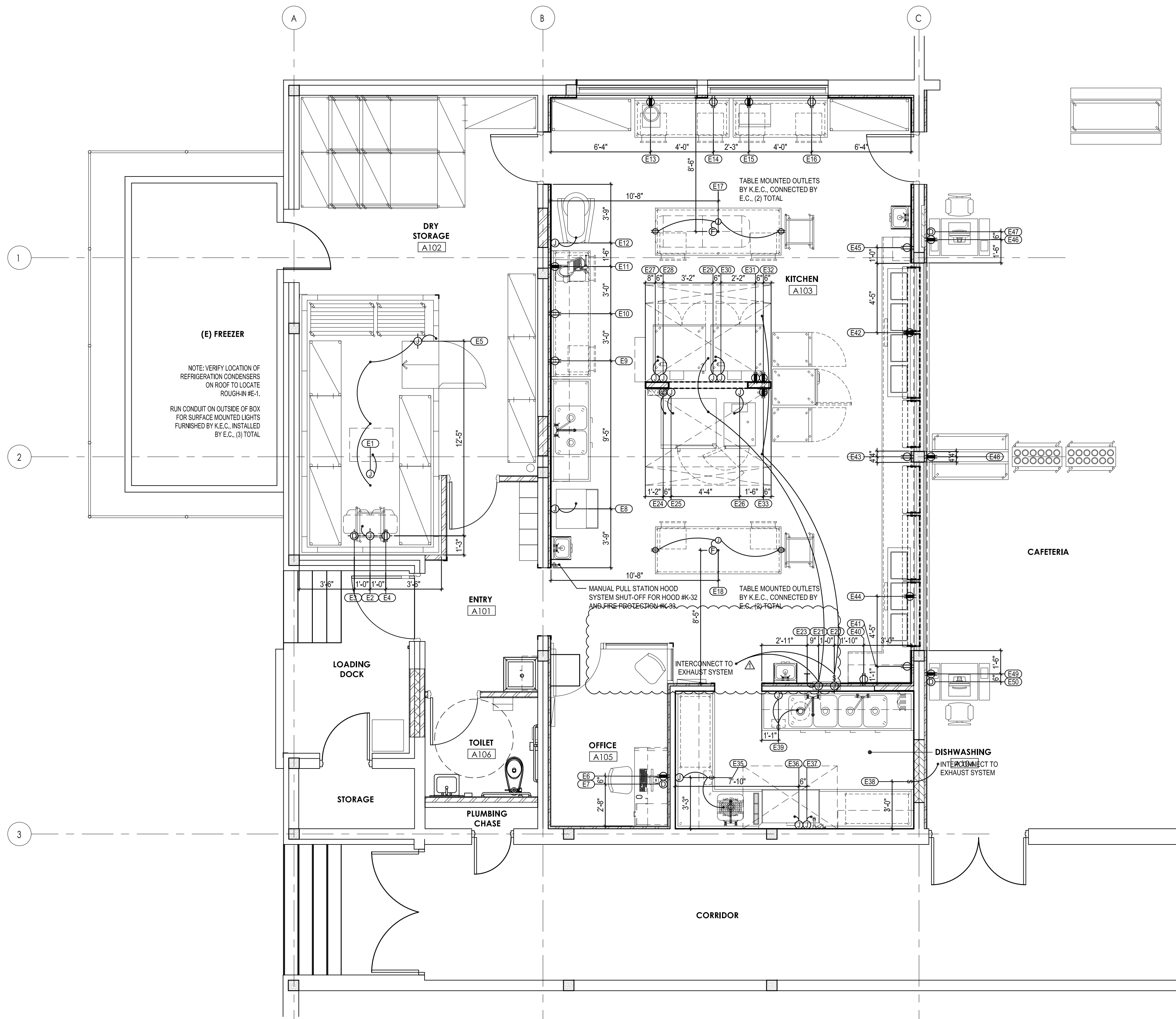
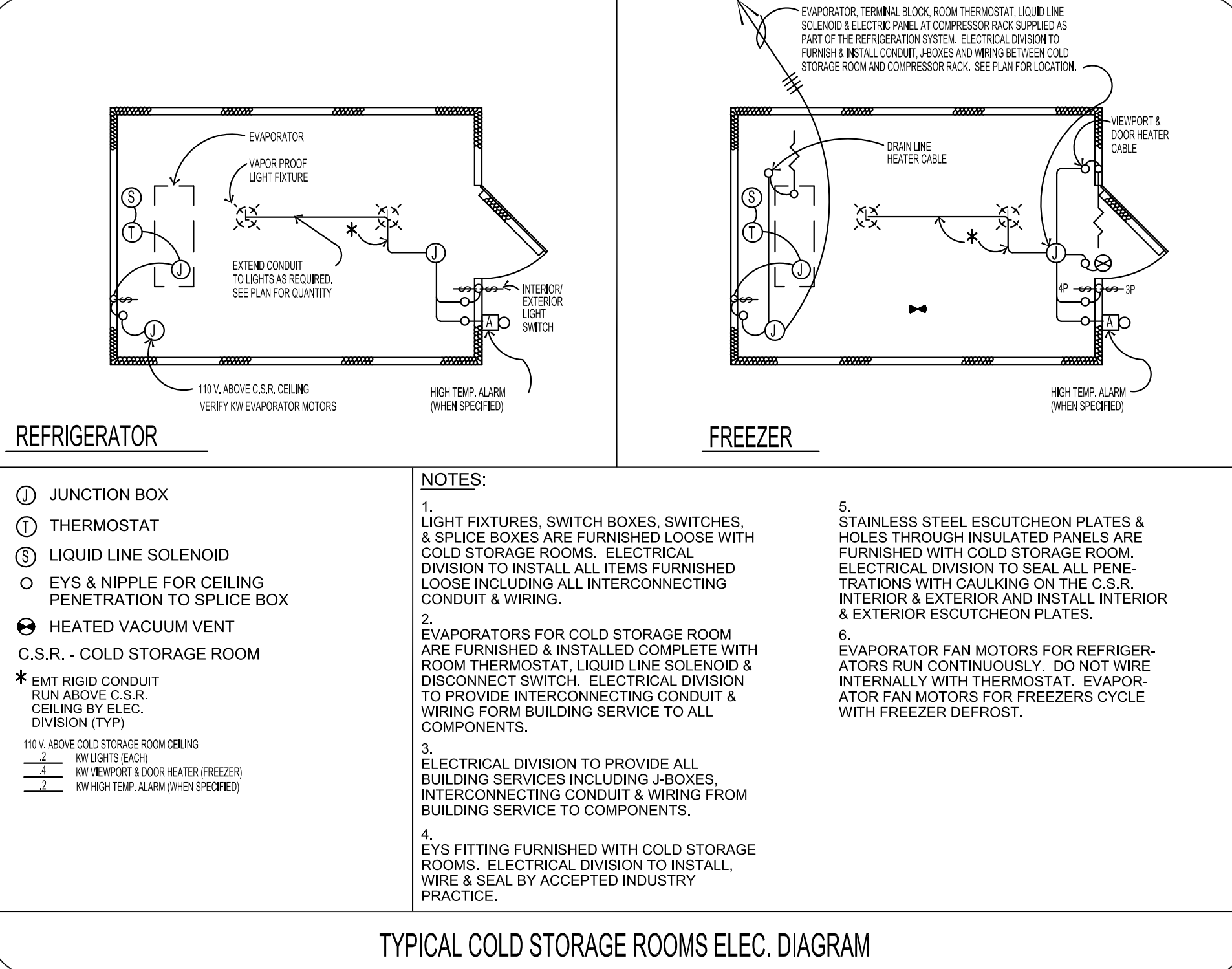

1 Food Service Equipment Electrical Requirement Plan
SCALE: 1/4" = 1'-0"

Ogden City School District
Highland Junior High School
Kitchen Remodel

325 Gramercy Ave
Ogden, Utah 84404

NJRA Project # 19799.00
Bid Set January 30, 2020
Add #1 February 17, 2020

Food Service
Equipment
Electrical
Requirement Plan